

Visit [www.carrier.com](http://www.carrier.com)

## Installation, Start-Up, and Operating Instructions For Sizes 040—120 Series 150

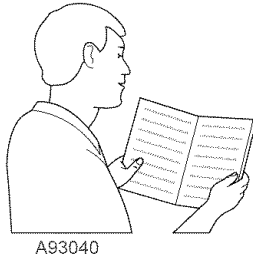

**NOTE:** Read the entire instruction manual before starting the installation.

This symbol → indicates a change since the last issue.

Index	Page
DIMENSIONAL DRAWING.....	3
SAFETY CONSIDERATIONS.....	2
Clearances to Combustibles.....	4
CODES AND STANDARDS.....	5
ELECTROSTATIC DISCHARGE (ESD) PRECAUTIONS.....	5
INTRODUCTION.....	5
APPLICATIONS.....	6
General.....	6
Upflow Applications.....	6
Downflow Applications.....	8
Horizontal Left (Supply-Air Discharge) Applications.....	9
Horizontal Right (Supply-Air Discharge) Applications.....	11
LOCATION.....	13
General.....	13
Furnace Location Relative to Cooling Equipment.....	14
Hazardous Locations.....	14
AIR FOR COMBUSTION AND VENTILATION.....	14
INSTALLATION.....	18
Leveling Legs (If Desired).....	18
Installation in Upflow and Downflow Applications.....	18
Installation In Horizontal Applications.....	18
Air Ducts.....	18
General.....	18
Ductwork Acoustical Treatment.....	20
Supply Air Connections.....	20
Return Air Connections.....	20
Filter Arrangement.....	20
Bottom Closure Panel.....	21
Gas Piping.....	22
Electrical Connections.....	23
115-v Wiring.....	23
24-v Wiring.....	24
Accessories.....	24
Venting.....	27
Removal of Existing Furnaces from Common Vent Systems.....	27
Combustion-Air and Vent Piping.....	28
Vent Termination.....	35
Multiventing.....	35



As an ENERGY STAR® Partner, Carrier Corporation has determined that this product meets the ENERGY STAR® guidelines for energy efficiency.

ISO 9001:2000

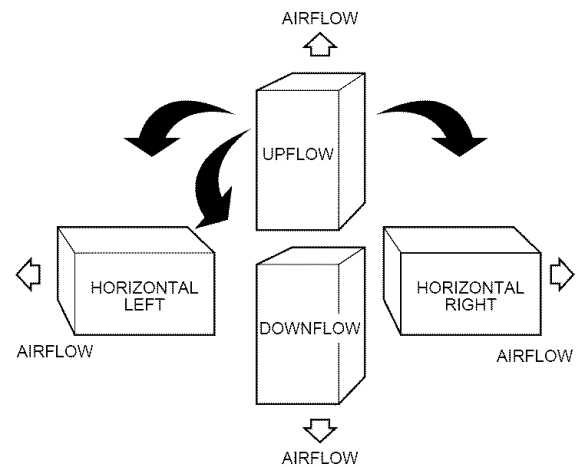

**Fig. 1—Multipoise Orientations**

A93041

Condensate Drain.....	35
General.....	35
Application.....	35
Condensate Drain Protection.....	36
START-UP, ADJUSTMENTS AND SAFETY CHECK.....	37
General.....	37
Prime Condensate Trap With Water.....	37
Purge Gas Lines.....	38
Sequence of Operation.....	38
Heating Mode.....	38
Cooling Mode.....	38
Continuous Blower Mode.....	38
Heat Pump Mode.....	39
Component Test.....	39
Adjustments.....	39
Set Gas Input Rate.....	39
Set Temperature Rise.....	44
Blower Off Delay (Heat Mode).....	44
Set Thermostat Heat Anticipator.....	45

Check Safety Controls .....	45
Check Primary Limit Control .....	45
Check Pressure Switch .....	45
CHECKLIST .....	45

## SAFETY CONSIDERATIONS

### ▲ CAUTION

#### FURNACE RELIABILITY HAZARD

Improper installation or misapplication of furnace may require excessive servicing or cause premature component failure.

Application of this furnace should be indoors with special attention given to vent sizing and material, gas input rate, air temperature rise, unit leveling, and unit sizing.

### ▲ WARNING

#### FIRE, EXPLOSION, ELECTRICAL SHOCK AND CARBON MONOXIDE POISONING HAZARD

Failure to follow this warning could result in electrical shock, fire, personal injury, or death.

Improper installation, adjustment, alteration, service, maintenance, or use can cause carbon monoxide poisoning, explosion, fire, electrical shock, or other conditions which may cause personal injury or property damage. Consult a qualified installer, service agency, local gas supplier, or your distributor or branch for information or assistance. The qualified installer or agency must use only factory-authorized and listed kits or accessories when modifying this product.

Installing and servicing heating equipment can be hazardous due to gas and electrical components. **Only trained and qualified personnel should install, repair, or service heating equipment.** Untrained personnel can perform basic maintenance functions such as cleaning and replacing air filters. All other operations must be performed by trained service personnel. When working on heating equipment, observe precautions in literature, on tags, and on labels attached to or shipped with unit and other safety precautions that may apply.

These instructions cover the minimum requirements and conform to existing national standards and safety codes. In some instances, these instructions exceed certain local codes and ordinances, especially those that may not have kept up with changing residential construction practices. We require these instructions as a minimum for a safe installation.

Wear safety glasses and work gloves. Have a fire extinguisher available during start-up and adjustment procedures and service calls.

### ▲ CAUTION

#### CUT HAZARD

Failure to follow this caution may result in personal injury. Sheet metal parts may have sharp edges or burrs. Use care and wear appropriate protective clothing and gloves when handling parts.

Recognize safety information. This is the safety-alert symbol ▲. When you see this symbol on the unit and in instructions or manuals, be alert to the potential for personal injury.

Understand these signal words DANGER, WARNING, and CAUTION. These words are used with the safety-alert symbol. DANGER identifies the most serious hazards which **will** result in severe personal injury or death. WARNING signifies hazards which **could** result in personal injury or death. CAUTION is used to identify unsafe practices which **may** result in minor personal injury or product and property damage. NOTE is used to highlight suggestions which **will** result in enhanced installation, reliability, or operation.

The 58MSA Multipoise Condensing Gas-Fired Furnaces are CSA (formerly AGA and CGA) design-certified for natural and propane gases (see furnace rating plate) and for installation in alcoves, attics, basements, closets, utility rooms, crawlspaces, and garages. The furnace is factory-shipped for use with natural gas. A CSA listed gas conversion kit is required to convert furnace for use with propane gas.

See Fig. 3 for required clearances to combustibles.

Maintain a 1-in. clearance from combustible materials to supply air ductwork for a distance of 36 inches horizontally from the furnace. See NFPA 90B or local code for further requirements.

These furnaces SHALL NOT be installed directly on carpeting, tile, or any other combustible material other than wood flooring. In downflow installations, factory accessory floor base MUST be used when installed on combustible materials and wood flooring. Special base is not required when this furnace is installed on manufacturer's Coil Assembly Part No. CD5 or CK5, or when Coil Box Part No. KCAKC is used. The design of this furnace line is NOT CSA (formerly AGA and CGA) design-certified for installation in recreation vehicles, manufactured mobile homes, or outdoors.

→ This furnace is designed for continuous return-air minimum temperature of 60°F db or intermittent operation down to 55°F db such as when used with a night setback thermometer. Return-air temperature must not exceed 80°F db. Failure to follow these return-air limits may affect reliability of heat exchangers, motors, and controls. (See Fig. 4.)

These furnaces are shipped with the drain and pressure tubes connected for UPFLOW applications. Minor modifications are required when used in DOWNFLOW, HORIZONTAL RIGHT, or HORIZONTAL LEFT (supply-air discharge direction) applications as shown in Fig. 1. See details in Applications section.

→ Install this furnace only in a location and position as specified in LOCATION and INSTALLATION sections of these instructions.

→ Combustion products must be discharged outdoors. Connect this furnace to an approved vent system only, as specified in the Combustion Air and Vent piping sections of these instructions.

→ Never test for gas leaks with an open flame. Use a commercially available soap solution made specifically for detection of leaks to check all connections as specified in the GAS PIPING section of these instructions.

→ Always install the furnace to operate within the furnace's intended rise range with a duct system which has an external static pressure within the allowable range as specified in the SET TEMPERATURE RISE section of these instructions.

→ When a furnace is installed so that supply ducts carry air circulated by the furnace to areas outside the space containing the furnace, the return air shall also be handled by ducts sealed to the furnace casing and terminating outside the space containing the furnace.

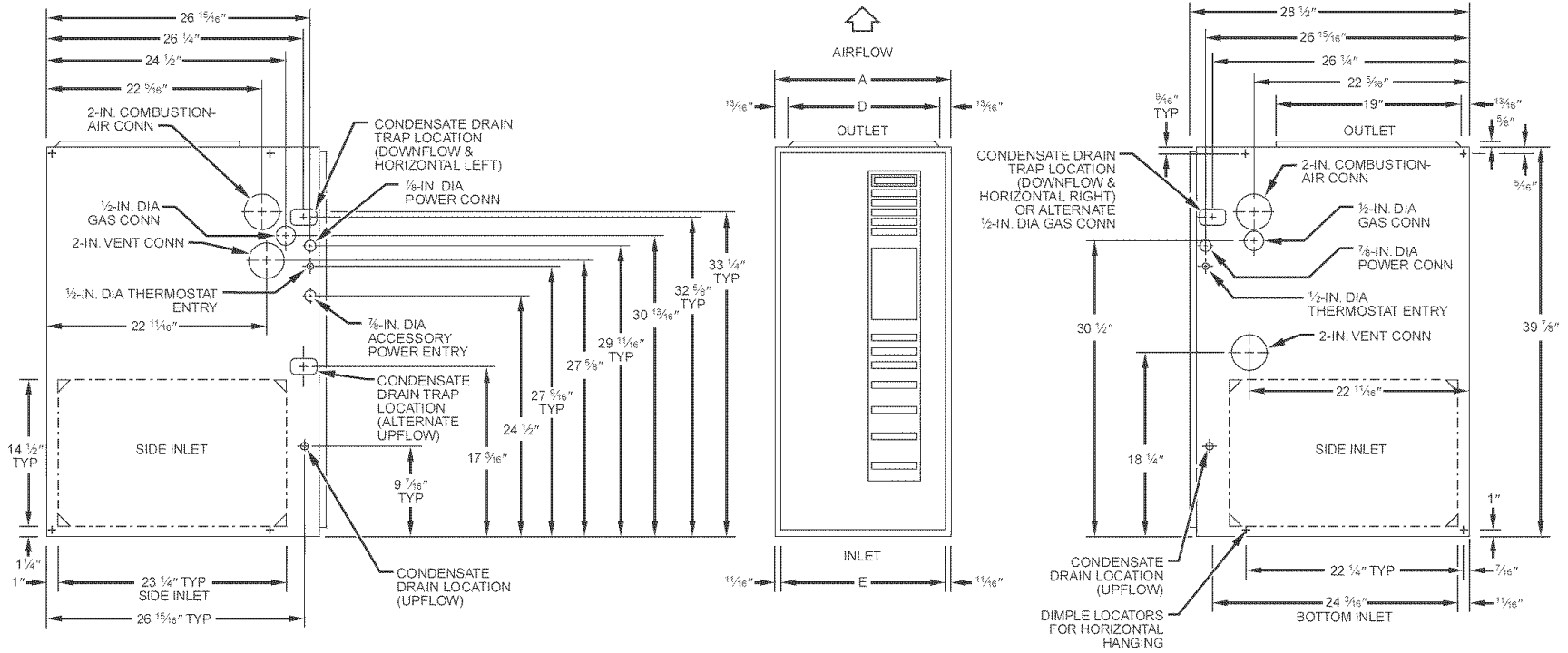

- NOTES:**
- Minimum return-air openings at furnace, based on metal duct. If flex duct is used, see flex duct manufacturer's recommendations for equivalent diameters.
  - Minimum return-air opening at furnace:
    - For 800 CFM—16-in. round or 14 1/2 x 12-in. rectangle.
    - For 1200 CFM—20-in. round or 14 1/2 x 19 1/2-in. rectangle.
    - For 1600 CFM—22-in. round or 14 1/2 x 23 1/4-in. rectangle.
    - For airflow requirements above 1800 CFM, see Air Delivery table in Product Data literature for specific use of single side inlets. The use of both side inlets, a combination of 1 side and the bottom, or the bottom only will ensure adequate return air openings for airflow requirements above 1800 CFM at 0.5 W.C. ESP.

**Dimensions (In.)**

UNIT SIZE	A	D	E
040-08	17-1/2	15-7/8	16
040-12	17-1/2	15-7/8	16
060-08	17-1/2	15-7/8	16
060-12	17-1/2	15-7/8	16
060-16	17-1/2	15-7/8	16
080-12	17-1/2	15-7/8	16
080-16	17-1/2	15-7/8	16
080-20	21	19-3/8	19-1/2
100-16	21	19-3/8	19-1/2
100-20	21	19-3/8	19-1/2
120-20	24-1/2	22-7/8	23

**Fig. 2—Dimensional Drawing**

→ A gas-fired furnace for installation in a residential garage must be installed as specified in the Hazardous Locations section of these instructions.

→ The furnace is not to be used for temporary heating of buildings or structures under construction unless the furnace installation and operation complies with the first CAUTION in the LOCATION section of these instructions.

These furnaces are shipped with the following materials to assist in proper furnace installation. These materials are shipped in the main blower compartment.

Installer Packet includes:

- Installation, Startup, and Operating Instructions
- Service and Maintenance Instructions
- User's Information Manual
- Warranty Certificate

Loose Parts Bag includes:

	Quantity
Pressure tube extension	1
Collector Box or condensate trap extension tube	1
Inducer housing drain tube	1
1/2-in CPVC street elbow	2
Drain tube coupling	1
Drain tube coupling grommet	1
Vent and combustion-air pipe support	2
Condensate trap hole filler plug	3
Vent and combustion-air intake hole filler plug	2
Combustion-air pipe perforated disk assembly	1
Vent Pipe Extension	1*

\* ONLY supplied with some furnaces.

## INSTALLATION

- This forced air furnace is equipped for use with natural gas at altitudes 0 - 10,000 ft (0 - 3,050m), except 140 size furnaces are only approved for altitudes 0 - 7,000 ft (0 - 2,135m).
- An accessory kit, supplied by the manufacturer, shall be used to convert to propane gas use or may be required for some natural gas applications.
- This furnace is for indoor installation in a building constructed on site. This furnace may be installed in a manufactured (mobile) home when stated on rating plate and using factory authorized kit.
- This furnace may be installed on combustible flooring in alcove or closet at **Minimum Inches Clearance To Combustible Construction** as described below.
- This furnace requires a special venting system. Refer to the installation instructions for parts list and method of installation. This furnace is for use with schedule-40 PVC, PVC-DWV, CPVC, or ABS-DWV pipe, and must not be vented in common with other gas-fired appliances. Construction through which vent/air intake pipes may be installed is maximum 24 inches (600 mm), minimum 3/4 inches (19 mm) thickness (including roofing materials).
- Cette fournaise à air pulsé est équipée pour utilisation avec gaz naturel et altitudes comprises entre 0 - 3,050m (0 - 10,000 pi), excepté queles fournaises de 140 taille sont pour altitudes comprises entre 0 - 2,135m (0 - 7,000pi).
- Utiliser une trousse de conversion, fournie par le fabricant, pour passer au gaz propane ou pour certaines installations au gaz naturel.
- Cette fournaise à air pulsé est pour installation à l'intérieur dans un bâtiment construit sur place. Cette fournaise à air pulsé peut être installée dans une maison préfabriquée (maison mobile) si prescrit par la plaque signalétique et si l'on utilise une trousse spécifiée par le fabricant.
- Cette fournaise peut être installée sur un plancher combustible dans un enfoncement ou un placard en observant les **Dégagement Minimum En Pouce Avec Éléments De Construction Combustibles**.
- Cette fournaise nécessite un système d'évacuation spécial. La méthode d'installation et la liste des pièces nécessaires figurent dans les instructions d'installation. Cette fournaise doit s'utiliser avec la tuyauterie des nomenclatures 40 PVC, PVC-DWV, CPVC, ou ABS-DWV et elle ne peut pas être ventilée conjointement avec d'autres appareils à gaz. Épaisseur de la construction au travers de laquelle il est possible de faire passer les tuyaux d'aération (admission/évacuation): 24 po (600 mm) maximum, 3/4 po (19mm) minimum (y compris la toiture).

For upflow and downflow applications, furnace must be installed level, or pitched within 1/2" of level. For a horizontal application, the furnace must be pitched minimum 1/4" to maximum of 1/2" forward for proper drainage. See Installation Manual for IMPORTANT unit support details on horizontal applications.

Pour des applications de flux ascendant et descendant, la fournaise doit être installée de niveau ou inclinée à pas plus de 1/2" du niveau. Pour une application horizontale, la fournaise doit être inclinée entre minimum 1/4" et maximum 1/2" du niveau pour le drainage approprié. En cas d'installation en position horizontale, consulter les renseignements IMPORTANTS sur le support dans le manuel d'installation.

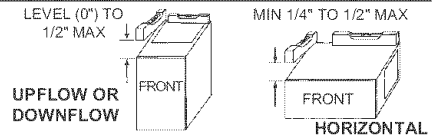

### MINIMUM INCHES CLEARANCE TO COMBUSTIBLE CONSTRUCTION

ALL POSITIONS:

- \* Minimum front clearance for service 24 inches (610mm).
- †† 140 size furnaces require 1 inch back clearance to combustible materials.

DOWNFLOW POSITIONS:

- † For installation on combustible floors only when installed on special base No. KGASB0201ALL, Coil Assembly, Part No. CD5 or CK5, or Coil Casing, Part No. KCAKC.

HORIZONTAL POSITIONS:

- Line contact is permissible only between lines formed by intersections of top and two sides of furnace jacket, and building joists, studs, or framing.
- § Clearance shown is for air inlet and air outlet ends.
- Ø 120 and 140 size furnaces require 1 inch bottom clearance to combustible materials.

### DÉGAGEMENT MINIMUM EN POUCE AVEC ÉLÉMENTS DE CONSTRUCTION COMBUSTIBLES

POUR TOUTS LES POSITIONS:

- \* Dégagement avant minimum de 610mm (24 po) pour l'entretien.
- †† Pour les fournaises de 140 taille, 1 po (25mm) dégagement des matériaux combustibles est requis au-arrière.

POUR LA POSITION COURANT DESCENDANT:

- † Pour l'installation sur le plancher combustible seulement quand on utilise la base spéciale, pièce n° KGASB0201ALL, l'ensemble serpentin, pièce n° CD5 ou CK5, ou le carter de serpentin, pièce n° KCAKC.

POUR LA POSITION HORIZONTALE:

- Le contact n'est permis qu'entre les lignes formées par les intersections du dessus et des deux côtés de la chemise de la fournaise, et des solives, des montants ou de la charpente du bâtiment.
- § La distance indiquée concerne l'extrémité du tuyau d'arrivée d'air et l'extrémité du tuyau de sortie d'air.
- Ø Pour les fournaises de 120 et 140 taille, 1 po (25mm) dégagement des matériaux combustibles est requis au-dessous.

This furnace is approved for UPFLOW, DOWNFLOW and HORIZONTAL installations.

Cette fournaise est approuvée pour l'installation HORIZONTALE et la circulation d'air VERS LE HAUT et VERS LE BAS.

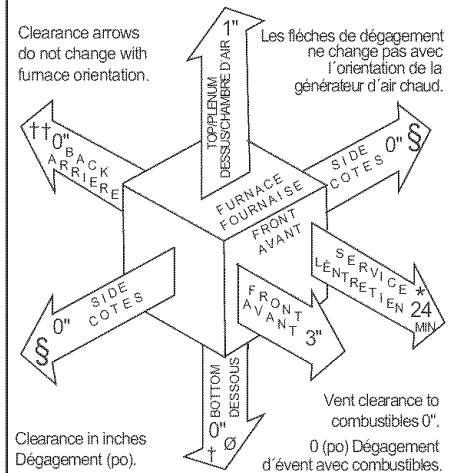

328066-201 REV. B LIT TOP

Fig. 3—Clearances to Combustibles

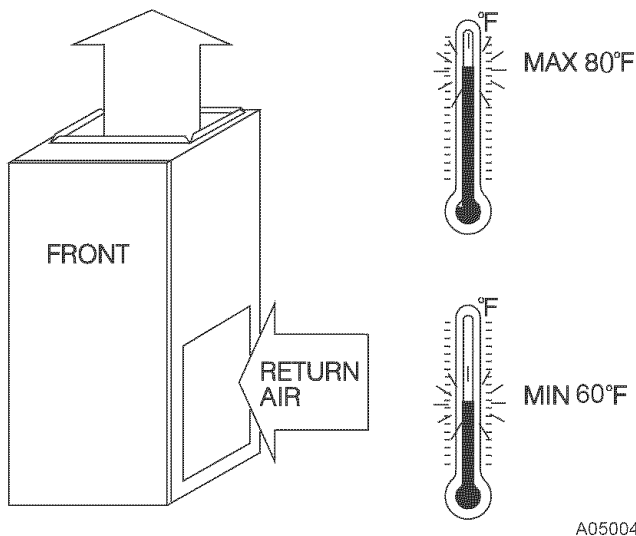

→ **Fig. 4—Return-Air Temperature**

For accessory installation details, refer to accessory installation instructions.

#### CODES AND STANDARDS

**Follow all national and local codes and standards in addition to these instructions.** The installation must comply with regulations of the serving gas supplier, local building, heating, plumbing, and other codes. In absence of local codes, the installation must comply with the national codes listed below and all authorities having jurisdiction.

In the United States and Canada, follow all codes and standards for the following:

#### Step 1—Safety

- US: National Fuel Gas Code (NFGC) NFPA 54-2002/ANSI Z223.1-2002 and the Installation Standards, Warm Air Heating and Air Conditioning Systems ANSI/NFPA 90B
- CANADA: National Standard of Canada, Natural Gas and Propane Installation Code (NSCNGPIC) CSA B149.1-00.

#### Step 2—General Installation

- US: NFGC and the NFPA 90B. For copies, contact the National Fire Protection Association Inc., Batterymarch Park, Quincy, MA 02269; or for only the NFGC contact the American Gas Association, 400 N. Capitol, N.W., Washington DC 20001
- • A manufactured (Mobile) home installation must conform with the *Manufactured Home Construction and Safety Standard, Title 24 CFR, Part 3280*, or when this standard is not applicable, the Standard for *Manufactured Home Installation (Manufactured Home Sites, Communities, and Set-Ups)*, *ANSI/NCs A225.1*, and/or *CAN/CSA-Z240, MH Series Mobile Homes*
- CANADA: NSCNGPIC. For a copy, contact Standard Sales, CSA International, 178 Rexdale Boulevard, Etobicoke (Toronto), Ontario, M9W 1R3, Canada.

#### Step 3—Combustion and Ventilation Air

- US: Section 8.3 of the NFGC, Air for Combustion and Ventilation
- CANADA: Part 7 of the NSCNGPIC, Venting Systems and Air Supply for Appliances

#### Step 4—Duct Systems

- US and CANADA: Air Conditioning Contractors Association (ACCA) Manual D, Sheet Metal and Air Conditioning Con-

tractors National Association (SMACNA), or American Society of Heating, Refrigeration, and Air Conditioning Engineers (ASHRAE) 2001 Fundamentals Handbook Chapter 34.

#### Step 5—Acoustical Lining and Fibrous Glass Duct

- US and CANADA: current edition of SMACNA, NFPA 90B as tested by UL Standard 181 for Class I Rigid Air Ducts

#### Step 6—Gas Piping and Gas Pipe Pressure Testing

- US: NFGC; chapters 2, 3, 4, and 9 and national plumbing codes in the state of Massachusetts:
- This product must be installed by a licensed plumber or gas fitter.
- When flexible connectors are used, the maximum length shall not exceed 36 inches.
- When lever type gas shutoffs are used they shall not exceed 36 inches.
- CANADA: NSCNGPIC Parts 3, 4, 5, A, B, E, and H.

#### Step 7—Electrical Connections

- US: National Electrical Code (NEC) ANSI/NFPA 70-2002
- CANADA: Canadian Electrical Code CSA C22.1

#### ELECTROSTATIC DISCHARGE (ESD) PRECAUTIONS

##### ⚠ CAUTION

##### UNIT DAMAGE HAZARD

Failure to follow this caution may result in damage to unit components.

Electrostatic discharge can affect electronic components. Take precautions during furnace installation and servicing to protect the furnace electronic control. Precautions will prevent electrostatic discharges from personnel and hand tools which are held during the procedure. These precautions will help to avoid exposing the control to electrostatic discharge by putting the furnace, the control, and the person at the same electrostatic potential.

1. Disconnect all power to the furnace. Multiple disconnects may be required. **DO NOT TOUCH THE CONTROL OR ANY WIRE CONNECTED TO THE CONTROL PRIOR TO DISCHARGING YOUR BODY'S ELECTROSTATIC CHARGE TO GROUND.**
2. Firmly touch a clean, unpainted, metal surface of the furnace chassis which is close to the control. Tools held in a person's hand during grounding will be satisfactorily discharged.
3. After touching the chassis you may proceed to service the control or connecting wires as long as you do nothing that recharges your body with static electricity (for example; **DO NOT** move or shuffle your feet, **DO NOT** touch ungrounded objects, etc.).
4. If you touch ungrounded objects (recharge your body with static electricity), firmly touch the unpainted metal surface of the furnace again before touching control or wires.
5. Use this procedure for installed and uninstalled (ungrounded) furnaces.
6. Before removing a new control from its container, discharge your body's electrostatic charge to ground to protect the control from damage. If the control is to be installed in a furnace, follow items 1 through 5 before bringing the control or yourself into contact with the furnace. Put all used and new controls into containers before touching ungrounded objects.
7. An ESD service kit (available from commercial sources) may also be used to prevent ESD damage.

#### INTRODUCTION

The model 58MSA 4-way multipoise, Gas-Fired, Category IV, condensing furnaces are available in model sizes ranging in gas input rates of 40,000 to 120,000 Btuh.

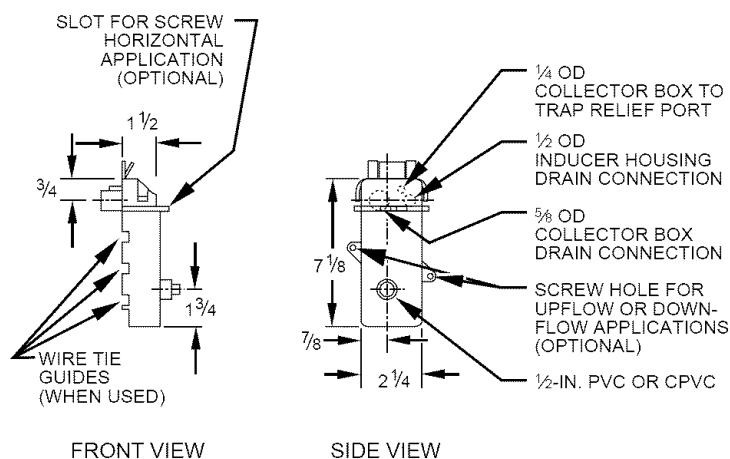
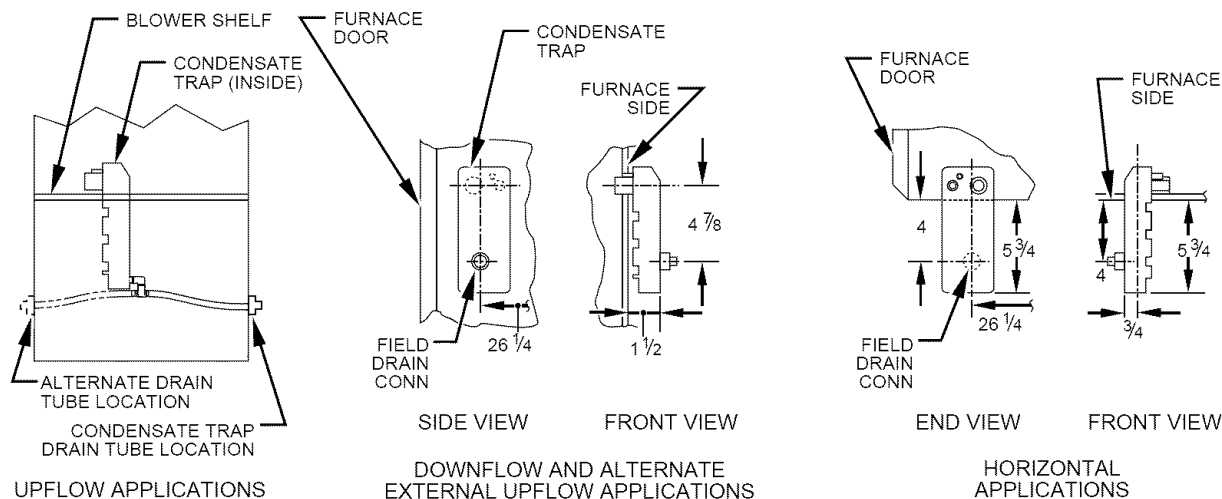

Fig. 5—Condensate Trap

A93026

**CAUTION**

**MINOR PROPERTY DAMAGE**

Failure to follow this caution may result in minor property damage.

Local codes may require a drain pan under entire furnace and condensate trap when a condensing furnace is used in an attic application or over a finished ceiling.

**APPLICATIONS**

**Step 1—General**

Some assembly and modifications are required for furnaces installed in any of the 4 applications shown in Fig. 1. All drain and pressure tubes are connected as shown in Fig. 6. See appropriate application instructions for these procedures.

**Step 2—Upflow Applications**

An upflow furnace application is where furnace blower is located below combustion and controls section of furnace, and conditioned air is discharged upwards.

**CONDENSATE TRAP LOCATION (FACTORY-SHIPPED ORIENTATION)**

The condensate trap is factory installed in the blower shelf and factory connected for UPFLOW applications. A factory-supplied tube is used to extend the condensate trap drain connection to the

desired furnace side for field drain attachment. See Condensate Trap Tubing (Factory-Shipped Orientation) section for drain tube extension details. (See Fig. 6.)

**CONDENSATE TRAP TUBING (FACTORY-SHIPPED ORIENTATION)**

**NOTE:** See Fig. 6 or tube routing label on main furnace door to confirm location of these tubes.

1. Collector Box Drain, Inducer Housing Drain, Relief Port, and Pressure Switch Tubes

These tubes are factory attached to the condensate trap and pressure switch ready for use in UPFLOW applications. These tubes can be identified by their connection location and also by a color label on each tube. These tubes are identified as follows: collector box drain tube (blue label), inducer housing drain tube (violet label or molded), relief port tube (green label), and pressure switch tube (pink label).

2. Condensate Trap Drain Tube

The condensate trap drain connection must be extended for field attachment by doing the following:

- a. Determine location of field drain connection. (See Fig. 2 or 6.)

**NOTE:** If internal filter is used, drain tube should be located to opposite side of casing from return duct attachment to assist in filter removal.

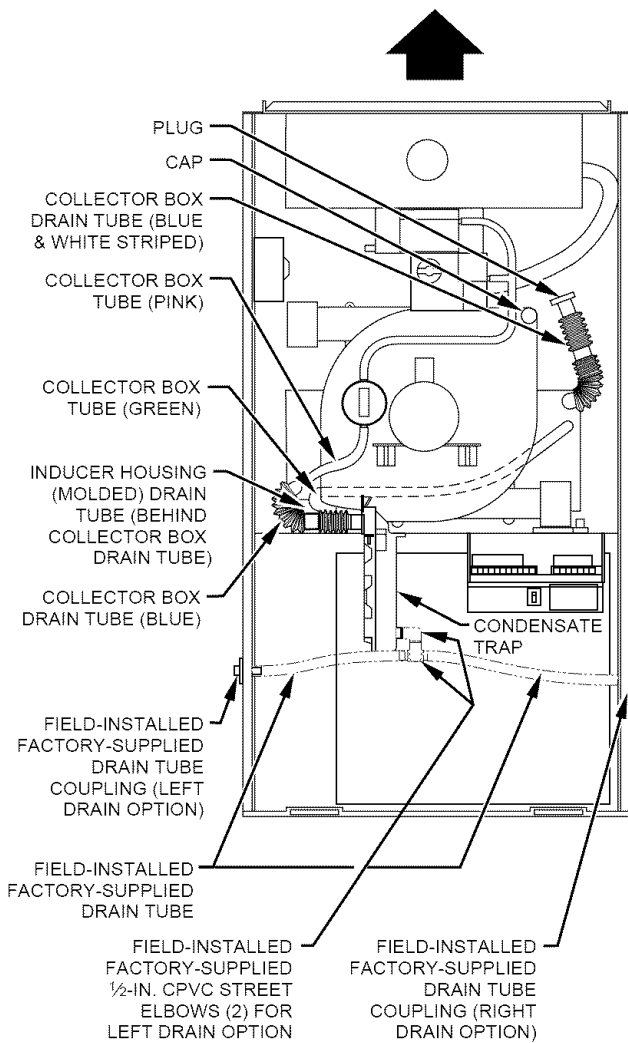

A94163

**Fig. 6—Factory-Shipped Upflow Tube Configuration (Shown With Blower Access Panel Removed)**

- b. Remove and discard casing drain hole plug button from desired side.
- c. Install drain tube coupling grommet (factory-supplied in loose parts bag) in selected casing hole.
- d. Slide drain tube coupling (factory-supplied in loose parts bag) through grommet ensuring long end of coupling faces blower.
- e. Cement 2 factory-supplied 1/2-in. street CPVC elbows to the rigid drain tube connection on the condensate trap. (See Fig. 6.) These elbows must be cemented together and cemented to condensate trap drain connection.

**NOTE:** Failure to use CPVC elbows may allow drain to kink and prevent draining.

- f. Connect larger diameter drain tube and clamp (factory-supplied in loose parts bag) to condensate trap and clamp securely.
- g. Route tube to coupling and cut to appropriate length.
- h. Attach tube to coupling and clamp securely.

**CONDENSATE TRAP LOCATION (ALTERNATE UPFLOW ORIENTATION)**

An alternate location for the condensate trap is the left-hand side of casing. (See Fig. 2 and 7.)

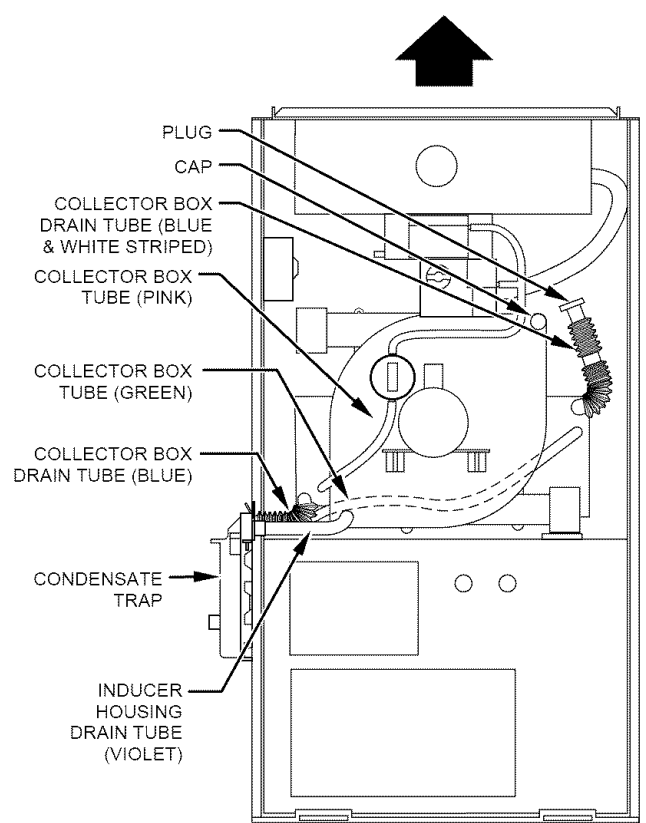

A94164

**Fig. 7—Alternate Upflow Tube Configuration and Trap Location**

**NOTE:** If the alternate left-hand side of casing location is used, the factory-connected drain and relief port tubes must be disconnected and modified for attachment. See Condensate Trap Tubing (Alternate Upflow Orientation) section for tubing attachment.

To relocate condensate trap to the left-hand side, perform the following:

1. Remove 3 tubes connected to condensate trap.
2. Remove trap from blower shelf by gently pushing tabs inward and rotating trap.
3. Install casing hole filler cap (factory-supplied in loose parts bag) into blower shelf hole where trap was removed.

<b>⚠ WARNING</b>
→ <b>CARBON MONOXIDE POISONING HAZARD</b> Failure to follow this warning could result in personal injury or death. Casing hole filler cap must be installed in blower shelf hole when condensate trap is relocated.

4. Install condensate trap into left-hand side casing hole by inserting tube connection stubs through casing hole and rotating until tabs snap into locking position.
5. Fill unused condensate trap casing holes with plastic filler caps (factory-supplied in loose parts bag).

**CONDENSATE TRAP TUBING (ALTERNATE UPFLOW ORIENTATION)**

**NOTE:** See Fig. 7 or tube routing label on main furnace door to confirm location of these tubes.

**1. Collector Box Drain Tube**

Connect collector box drain tube (blue label) to condensate trap.

**NOTE:** On 17-1/2-in. wide furnaces ONLY, cut tube between corrugated sections to prevent kinks from occurring.

**2. Inducer Housing Drain Tube**

a. Remove and discard LOWER (molded) inducer housing drain tube which was previously connected to condensate trap.

b. Use inducer housing drain extension tube (violet label and factory-supplied in loose parts bag) to connect LOWER inducer housing drain connection to the condensate trap.

c. Determine appropriate length, cut, and connect tube.

d. Clamp tube to prevent any condensate leakage.

**3. Relief Port Tube**

a. Connect relief port tube (green label) to condensate trap.

b. Use smaller diameter tube (factory-supplied in loose parts bag) to extend this tube if required.

c. Determine appropriate length, cut, and connect tube.

**CONDENSATE TRAP FIELD DRAIN ATTACHMENT**

Refer to Condensate Drain section for recommendations and procedures.

**PRESSURE SWITCH TUBING**

The LOWER collector box pressure tube (pink label) is factory connected to the pressure switch and should not require any modification.

**NOTE:** See Fig. 6 or 7 or tube routing label on main furnace door to check for proper connections.

**UPPER COLLECTOR BOX AND INDUCER HOUSING (UNUSED) DRAIN CONNECTIONS**

Upper Collector Box Drain Connection

Attached to the UPPER collector box drain connection is a factory-installed corrugated, plugged tube (blue and white striped label). This tube is plugged to prevent condensate leakage in this application. Ensure this tube is plugged.

**NOTE:** See Fig. 6 or 7 or tube routing label on main furnace door to check for proper connections.

Upper Inducer Housing Drain Connection

Attached to the UPPER (unused) inducer housing drain connection is a cap and clamp. This cap is used to prevent condensate leakage in this application. Ensure this connection is capped.

**NOTE:** See Fig. 6 or 7 or tube routing label on main furnace door to check for proper connections.

**CONDENSATE TRAP FREEZE PROTECTION**

Refer to Condensate Drain Protection section for recommendations and procedures.

**Step 3—Downflow Applications**

A downflow furnace application is where furnace blower is located above combustion and controls section of furnace, and conditioned air is discharged downwards.

**CONDENSATE TRAP LOCATION**

The condensate trap must be removed from the factory-installed blower shelf location and relocated in selected application location as shown in Fig. 2, 8, or 9.

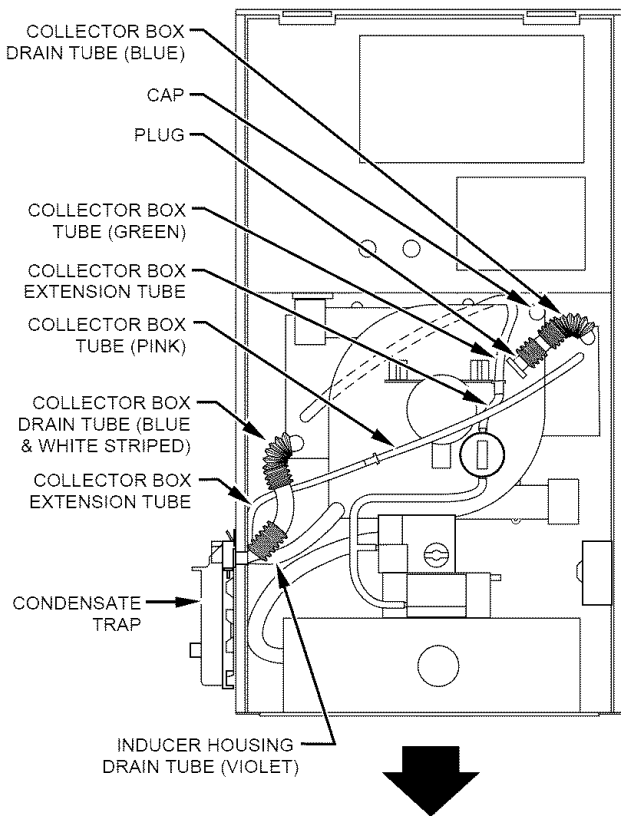

**Fig. 8—Downflow Tube Configuration (Left-Hand Trap Installation)**

A94165

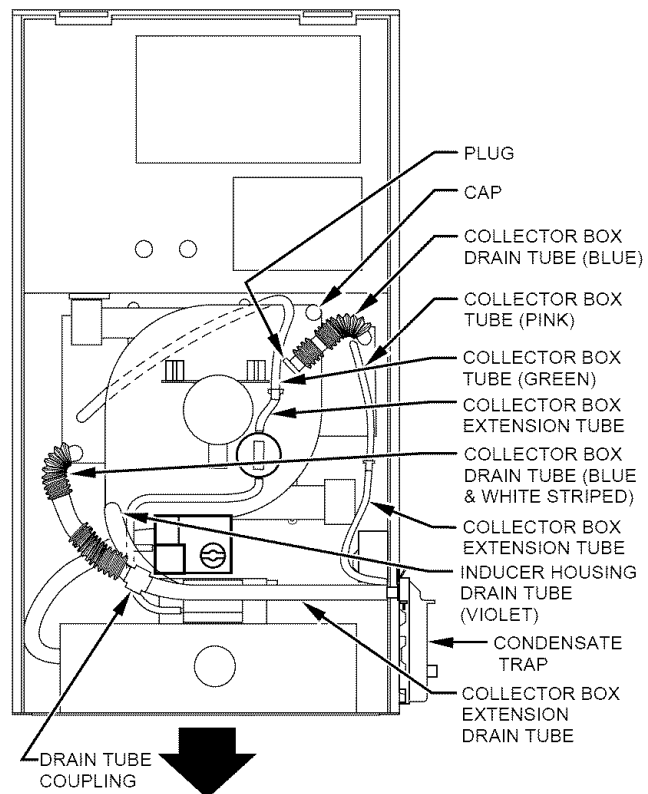

**Fig. 9—Downflow Tube Configuration (Right-Hand Trap Installation)**

A94166



To relocate condensate trap from the blower shelf to desired location, perform the following:

1. Remove 3 tubes connected to condensate trap.
2. Remove trap from blower shelf by gently pushing tabs inward and rotating trap.
3. Install casing hole filler cap (factory-supplied in loose parts bag) into blower shelf hole where trap was removed.

### **▲ WARNING**

#### **CARBON MONOXIDE POISONING HAZARD**

Failure to follow this warning could result in personal injury or death.

Casing hole filler cap must be installed in blower shelf hole when condensate trap is relocated.

4. Install condensate trap into desired casing hole by inserting tube connection stubs through casing hole and rotating until tabs snap into locking position.
5. Fill unused condensate trap casing holes with plastic filler caps (factory-supplied in loose parts bag).

#### CONDENSATE TRAP TUBING

**NOTE:** See Fig. 8 or 9 or tube routing label on main furnace door to check for proper connections.

1. Collector Box Drain Tube
  - a. Remove factory-installed plug from LOWER collector box drain tube (blue and white striped label).
  - b. Install removed clamp and plug into UPPER collector box drain tube (blue label) which was connected to condensate trap.
  - c. Connect LOWER collector box drain connection to condensate trap.
    - (1.) Condensate Trap Located on Left Side of Casing
      - (a.) Connect LOWER collector box drain tube (blue and white striped label) to condensate trap. Tube does not need to be cut.
      - (b.) Clamp tube to prevent any condensate leakage.
    - (2.) Condensate Trap Located on Right Side of Casing
      - (a.) Install drain tube coupling (factory-supplied in loose parts bag) into collector box drain tube (blue and white striped label) which was previously plugged.
      - (b.) Connect larger diameter drain tube (factory-supplied in loose parts bag) to drain tube coupling, extending collector box drain tube for connection to condensate trap.
      - (c.) Route extended collector box drain tube between gas valve and inlet housing as shown in Fig. 9.
      - (d.) Determine appropriate length and cut.
      - (e.) Connect to condensate trap.
      - (f.) Clamp tube to prevent any condensate leakage.
2. Inducer Housing Drain Tube
  - a. Remove factory-installed cap and clamp from LOWER inducer housing drain connection.
  - b. Remove and discard UPPER (molded) inducer housing drain tube which was previously connected to condensate trap.
  - c. Install cap and clamp on UPPER inducer housing drain connection where molded drain tube was removed.

- d. Use inducer housing drain tube (violet label and factory-supplied in loose parts bag) to connect LOWER inducer housing drain connection to the condensate trap.
- e. Connect inducer housing drain connection to condensate trap.
  - (1.) Condensate Trap Located on Left Side of Casing
    - (a.) Determine appropriate length and cut.
    - (b.) Connect tube to condensate trap.
    - (c.) Clamp tube to prevent any condensate leakage.
  - (2.) Condensate Trap Located on Right Side of Casing
    - (a.) Route inducer housing drain tube (violet label) between gas valve and inlet housing behind collector box drain tube.
    - (b.) Determine appropriate length and cut.
    - (c.) Connect tube to condensate trap.
    - (d.) Clamp tube to prevent any condensate leakage.
3. Relief Port Tube

Refer to Pressure Switch Tubing section for connection procedure.

#### CONDENSATE TRAP FIELD DRAIN ATTACHMENT

Refer to Condensate Drain section for recommendations and procedures.

#### PRESSURE SWITCH TUBING

One collector box pressure tube (pink label) is factory connected to the pressure switch for use when furnace is installed in UPFLOW applications. This tube **MUST** be disconnected and used for the condensate trap relief port tube. The other collector box pressure tube (green label) which was factory connected to the condensate trap relief port connection **MUST** be connected to the pressure switch in DOWNFLOW or HORIZONTAL RIGHT applications.

**NOTE:** See Fig. 8 or 9 or tube routing label on main furnace door to check for proper connections.

Relocate tubes as described below.

1. Disconnect collector box pressure tube (pink label) attached to pressure switch.
2. Use smaller diameter tube (factory-supplied in loose parts bag) to extend collector box pressure tube (green label) which was previously connected to condensate trap relief port connection.
3. Connect collector box pressure tube (green label) to pressure switch connection labeled "collector box."
4. Use remaining smaller diameter tube (factory-supplied in loose parts bag) to extend collector box pressure tube (pink label) which was previously connected to pressure switch.
5. Route this extended tube (pink label) to condensate trap relief port connection.
6. Determine appropriate length, cut, and connect tube.
7. Clamp tube to relief port connection.

#### CONDENSATE TRAP FREEZE PROTECTION

Refer to Condensate Drain Protection section for recommendations and procedures.

#### **Step 4—Horizontal Left (Supply-Air Discharge) Applications**

A horizontal left furnace application is where furnace blower is located to the right of combustion and controls section of furnace, and conditioned air is discharged to the left.

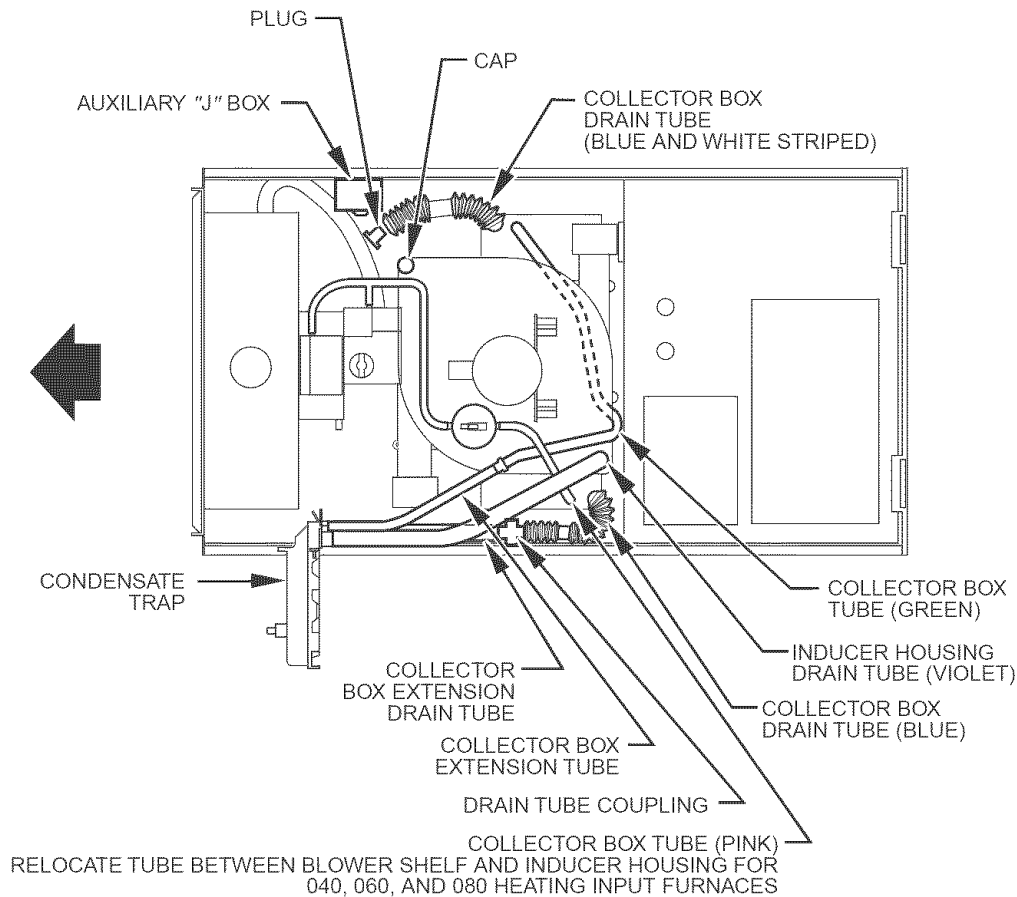

**Fig. 10—Horizontal Left Tube Configuration**

A00215

**CONDENSATE TRAP LOCATION**

The condensate trap must be removed from the factory-installed blower shelf location and relocated in selected application location as shown in Fig. 2 or 10.

To relocate condensate trap from the blower shelf to desired location, perform the following:

1. Remove 3 tubes connected to condensate trap.
2. Remove trap from blower shelf by gently pushing tabs inward and rotating trap.
3. Install casing hole filler cap (factory-supplied in loose parts bag) into blower shelf hole where trap was removed.

**⚠ WARNING**

**→ CARBON MONOXIDE POISONING HAZARD**  
 Failure to follow this warning could result in personal injury or death.  
 Casing hole filler cap must be installed in blower shelf hole when condensate trap is relocated.

4. Install condensate trap into casing hole by inserting tube connection stubs through casing hole and rotating until tabs snap into locking position.
5. Fill unused condensate trap casing holes with plastic filler caps (factory-supplied in loose parts bag).

**CONDENSATE TRAP TUBING**

**NOTE:** See Fig. 10 or tube routing label on main furnace door to check for proper connections.

1. Collector Box Drain Tube
  - a. Install drain tube coupling (factory-supplied in loose parts bag) into collector box drain tube (blue label) which was previously connected to condensate trap.
  - b. Connect large diameter drain tube and clamp (factory-supplied in loose parts bag) to drain tube coupling, extending collector box drain tube.
  - c. Route extended tube (blue label) to condensate trap and cut to appropriate length.
  - d. Clamp tube to prevent any condensate leakage.
2. Inducer Housing Drain Tube
  - a. Remove and discard LOWER (molded) inducer housing drain tube which was previously connected to condensate trap.
  - b. Use inducer housing drain extension tube (violet label and factory-supplied in loose parts bag) to connect LOWER inducer housing drain connection to the condensate trap.
  - c. Determine appropriate length, cut, and connect tube.
  - d. Clamp tube to prevent any condensate leakage.
3. Relief Port Tube
  - a. Use smaller diameter tube (factory-supplied in loose parts bag) to extend collector box tube (green label) which was previously connected to the condensate trap.
  - b. Route extended collector box pressure tube to relief port connection on the condensate trap.
  - c. Determine appropriate length, cut, and connect tube.
  - d. Clamp tube to prevent any condensate leakage.

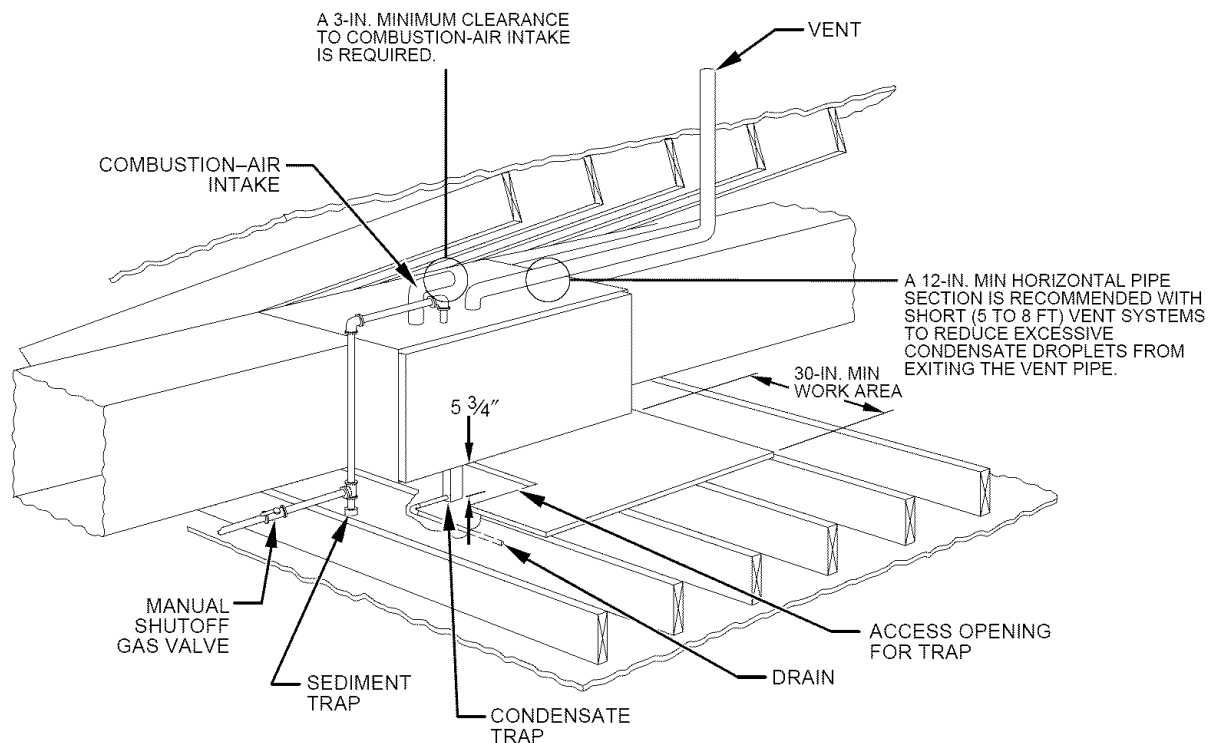

**NOTE:** LOCAL CODES MAY REQUIRE A DRAIN PAN UNDER THE FURNACE AND CONDENSATE TRAP WHEN A CONDENSING FURNACE IS INSTALLED ABOVE FINISHED CEILINGS.

**Fig. 11—Attic Location and Working Platform**

A96184

#### CONDENSATE TRAP FIELD DRAIN ATTACHMENT

Refer to Condensate Drain section for recommendations and procedures.

#### PRESSURE SWITCH TUBING

The LOWER collector box pressure tube (pink label) is factory connected to the pressure switch for use when furnace is installed in UPFLOW applications. This tube **MUST** be disconnected, extended, rerouted, and then reconnected to the pressure switch in HORIZONTAL LEFT applications.

**NOTE:** See Fig. 10 or tube routing label on main furnace door to check for proper connections.

Modify tube as described below.

1. Disconnect collector box pressure tube (pink label) attached to pressure switch.
2. Use smaller diameter tube (factory-supplied in loose parts bag) to extend tube disconnected in item 1.
3. Route extended tube:
  - a. Behind inducer housing.
  - b. Between blower shelf and inducer housing.
  - c. Behind inducer motor bracket.
  - d. Between inducer motor and pressure switch.
4. Determine appropriate length, cut, and reconnect tube to pressure switch connection labeled COLLECTOR BOX.

#### CONDENSATE TRAP FREEZE PROTECTION

Refer to Condensate Drain Protection section for recommendations and procedures.

#### CONSTRUCT A WORKING PLATFORM

Construct working platform where all required furnace clearances are met. (See Fig. 3 and 11.)

#### **CAUTION**

##### **UNIT MAY NOT OPERATE**

Failure to follow this caution may result in intermittent unit operation. The condensate trap **MUST** be installed below furnace. See Fig. 5 for dimensions. The drain connection to condensate trap must also be properly sloped to an open drain.

**NOTE:** Vent pipe length is restricted to a minimum of 5 ft. (See Table 8.)

**NOTE:** A 12-in. minimum horizontal pipe section is recommended with short (5 to 8 ft) vent systems. This recommendation is to reduce excessive condensate droplets from exiting the vent pipe. (See Fig. 11 or 38.)

#### **Step 5—Horizontal Right (Supply-Air Discharge) Applications**

A horizontal right furnace application is where furnace blower is located to the left of combustion and controls section of furnace, and conditioned air is discharged to the right.

#### **CAUTION**

##### **MINOR PROPERTY DAMAGE**

Failure to follow this caution may result in minor property damage. Local codes may require a drain pan under entire furnace and condensate trap when a condensing furnace is used in attic application or over a finished ceiling.

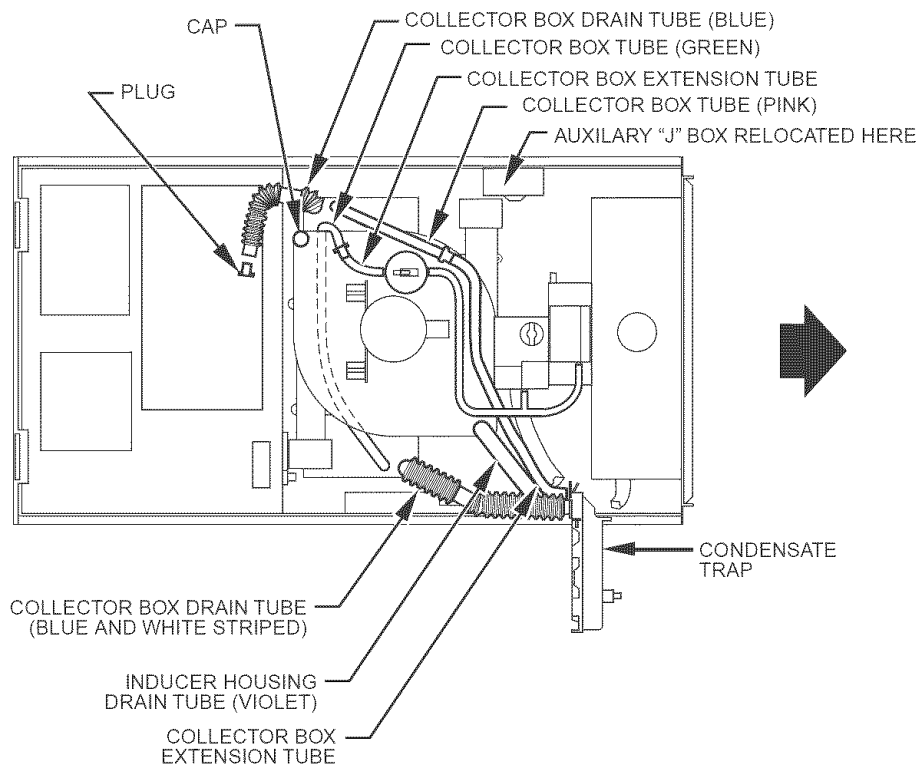

**Fig. 12—Horizontal Right Tube Configuration**

A00214

**NOTE:** In Canada, installations shall be in accordance with current NSCSGPIIC Installation Codes and/or local codes.

**NOTE:** The auxiliary junction box (J-Box) **MUST** be relocated to opposite side of furnace casing. (See Fig. 12.) See Electrical Connection section for J-Box relocation.

**CONDENSATE TRAP LOCATION**

The condensate trap must be removed from the factory-installed blower shelf location and relocated in selected application location as shown in Fig. 2 or 12.

To relocate condensate trap from the blower shelf to desired location, perform the following:

1. Remove 3 tubes connected to condensate trap.
2. Remove trap from blower shelf by gently pushing tabs inward and rotating trap.
3. Install casing hole filler cap (factory-supplied in loose parts bag) into blower shelf hole where trap was removed.

**⚠ WARNING**

**CARBON MONOXIDE POISONING HAZARD**  
 Failure to follow this warning could result in personal injury or death.  
 Casing hole filler cap must be installed in blower shelf hole when condensate trap is relocated.

4. Install condensate trap into casing hole by inserting tube connection stubs through casing hole and rotating until tabs snap into locking position.
5. Fill unused condensate trap casing holes with plastic filler caps (factory-supplied in loose parts bag).

**CONDENSATE TRAP TUBING**

**NOTE:** See Fig. 12 or tube routing label on main furnace door to check for proper connections.

1. Collector Box Drain Tube
  - a. Remove factory-installed plug from LOWER collector box drain tube (blue and white striped label).
  - b. Install removed clamp and plug into UPPER collector box drain tube (blue label) which was previously connected to condensate trap.
  - c. Connect LOWER collector box drain tube (blue and white striped label) to condensate trap. Tube does not need to be cut.
  - d. Clamp tube to prevent any condensate leakage.
2. Inducer Housing Drain Tube
  - a. Remove factory-installed cap and clamp from LOWER inducer housing drain connection.
  - b. Remove and discard UPPER (molded) inducer housing drain tube which was previously connected to condensate trap.
  - c. Install cap and clamp on UPPER inducer housing drain connection where molded drain tube was removed.
  - d. Use inducer housing drain extension tube (violet label and factory-supplied in loose parts bag) to connect LOWER inducer housing drain connection to condensate trap.
  - e. Determine appropriate length, cut, and connect tube to condensate trap.
  - f. Clamp tube to prevent any condensate leakage.
3. Relief Port Tube
 

Refer to Pressure Switch Tubing section for connection procedure.

## CONDENSATE TRAP FIELD DRAIN ATTACHMENT

Refer to Condensate Drain section for recommendations and procedures.

## PRESSURE SWITCH TUBING

One collector box pressure tube (pink label) is factory connected to the pressure switch for use when furnace is installed in UPFLOW applications. This tube **MUST** be disconnected and used for the condensate trap relief port tube. The other collector box pressure tube (green label) which was factory connected to the condensate trap relief port connection **MUST** be connected to the pressure switch in DOWNFLOW or HORIZONTAL RIGHT applications.

**NOTE:** See Fig. 12 or tube routing label on main furnace door to check for proper connections.

Relocate tubes as described below.

1. Disconnect collector box pressure tube (pink label) attached to pressure switch.
2. Use smaller diameter tube (factory-supplied in loose parts bag) to extend collector box pressure tube (green label) which was previously connected to condensate trap relief port connection.
3. Route extended collector box pressure tube behind inducer motor bracket then between inducer motor and pressure switch.
4. Connect collector box pressure tube (green label) to pressure switch connection labeled COLLECTOR BOX.
5. Use remaining smaller diameter tube (factory-supplied in loose parts bag) to extend collector box pressure tube (pink label) which was previously connected to pressure switch.
6. Route this extended tube (pink label) to condensate trap relief port connection.
7. Determine appropriate length, cut, and connect tube.
8. Clamp tube to relief port connection.

## CONDENSATE TRAP FREEZE PROTECTION

Refer to Condensate Drain Protection section for recommendations and procedures.

## CONSTRUCT A WORKING PLATFORM

Construct working platform where all required furnace clearances are met. (See Fig. 3 and 11.)

### ▲ CAUTION

#### UNIT MAY NOT OPERATE

Failure to follow this caution may result in intermittent unit operation.

The condensate trap **MUST** be installed below furnace. See Fig. 5 for dimensions. The drain connection to condensate trap must also be properly sloped to an open drain.

**NOTE:** Vent pipe length is restricted to a minimum of 5 ft. (See Table 8.)

**NOTE:** A 12-in. minimum horizontal pipe section is recommended with short (5 to 8 ft) vent systems. This recommendation is to reduce excessive condensate droplets from exiting the vent pipe. (See Fig. 11 or 38.)

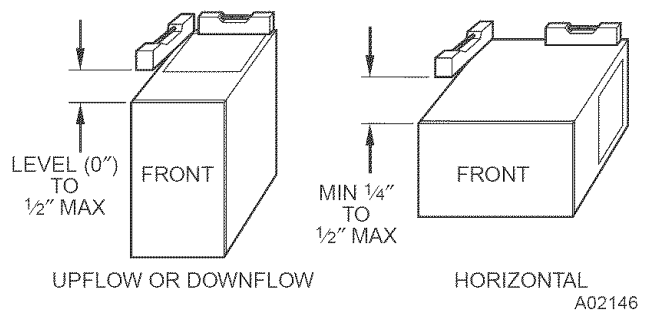

Fig. 13—Furnace Location for Proper Condensate Drainage

## LOCATION

### Step 1—General

This furnace must

- be installed so the electrical components are protected from water.
- not be installed directly on any combustible material other than wood flooring (refer to SAFETY CONSIDERATIONS).
- be located so combustion-air and vent pipe maximum lengths are not exceeded. Refer to Table 8.
- be located where available electric power and gas supplies meet specifications on the furnace rating plate.
- be attached to an air distribution system and be located as close to the center of the distribution system as possible. Refer to Air Ducts section.
- be provided with ample space for servicing and cleaning. Always comply with minimum fire protection clearances shown on the furnace clearance-to-combustibles label.

**NOTE:** For upflow/downflow applications install furnace so that it is level or pitched forward within 1/2-in. for proper furnace operation. For horizontal applications pitch 1/4-in. minimum to 1/2-in. maximum forward to ensure proper condensate drainage from secondary heat exchangers. (See Fig. 13.)

When a furnace is installed so that supply ducts carry air circulated by the furnace to areas outside the space containing the furnace, the return air shall also be handled by duct(s) sealed to furnace casing and terminating outside the space containing the furnace to ensure there will not be a negative pressure condition within equipment room or space.

### ▲ CAUTION

#### UNIT DAMAGE HAZARD

Failure to follow this caution may result in intermittent unit operation.

Do not install furnace in a corrosive or contaminated atmosphere. Make sure all combustion and circulating air requirements are met.

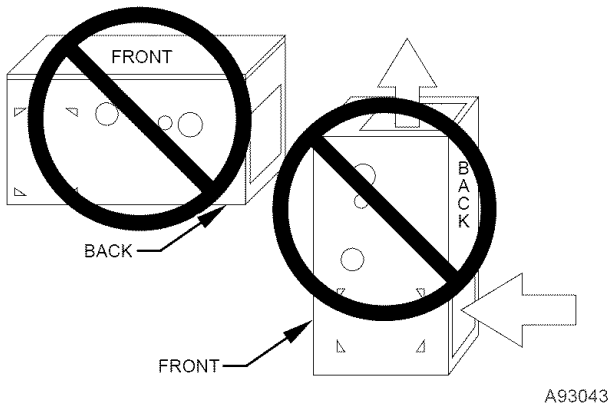

Fig. 14—Prohibit Installation on Back

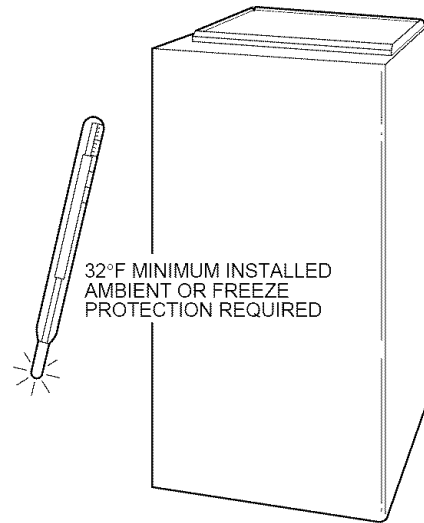

Fig. 15—Freeze Protection

**CAUTION**

**UNIT DAMAGE HAZARD**

This gas furnace may be used for construction heat provided that:

-The furnace is permanently installed with all electrical wiring, piping, air filters, venting and ducting installed according to these installation instructions. A return air duct is provided, sealed to the furnace casing, and terminated outside the space containing the furnace. This prevents a negative pressure condition as created by the circulating air blower, causing a flame rollout and/or drawing combustion products into the structure.

-The furnace is controlled by a thermostat. It may not be "hot wired" to provide heat continuously to the structure without thermostatic control.

-Clean outside air is provided for combustion. This is to minimize the corrosive effects of adhesives, sealers and other construction materials. It also prevents the entrainment of drywall dust into combustion air, which can cause fouling and plugging of furnace components.

-The temperature of the return air to the furnace is maintained between 55°F (13°C) and 80°F (27°C), with no evening setback or shutdown. The use of the furnace while the structure is under construction is deemed to be intermittent operation per our installation instructions.

-The air temperature rise is within the rated rise range on the furnace rating plate, and the firing rate has been set to the nameplate value.

-The filters used to clean the circulating air during the construction process must be either changed or thoroughly cleaned prior to occupancy.

-The furnace, ductwork and filters are cleaned as necessary to remove drywall dust and construction debris from all HVAC system components after construction is completed.

-After construction is complete, verify furnace operating conditions including ignition, input rate, temperature rise and venting, according to the manufacturer's instructions.

**WARNING**

**FIRE, INJURY OR DEATH HAZARD**

Failure to follow this warning could result in fire, personal injury, or death.

Do **not** install furnace on its back. (See Fig. 14.) Safety control operation will be adversely affected. Never connect return-air ducts to back of furnace.

**CAUTION**

**UNIT DAMAGE HAZARD**

Failure to follow this caution may result in minor property or unit damage.

If this furnace is installed in an unconditioned space where ambient temperatures may be 32°F or lower, freeze protection measures must be taken. (See Fig. 15.)

**Step 3—Hazardous Locations**

**WARNING**

**FIRE, EXPLOSION, INJURY OR DEATH HAZARD**

Improper location or inadequate protection could result in fire or explosion.

When the furnace is installed in a residential garage, the burners and ignition sources must be located at least 18 in. above the floor. The furnace must be located or protected to avoid physical damage by vehicles. When the furnace is installed in a public garage, airplane hangar, or other building having a hazardous atmosphere, the furnace must be installed in accordance with the NFGC or NSCNIGPIC. (See Fig. 16.)

**AIR FOR COMBUSTION AND VENTILATION**

Provisions for adequate combustion, ventilation, and dilution air must be provided in accordance with:

- **U.S. Installations:** Section 8.3 of the NFGC, Air for Combustion and Ventilation and applicable provisions of the local building codes.
- **Canadian Installations:** Part 7 of the NSCNIGPIC, Venting Systems and Air Supply for Appliances and all authorities having jurisdiction.

**Step 2—Furnace Location Relative to Cooling Equipment**

The cooling coil must be installed parallel with or on downstream side of furnace to avoid condensation in heat exchanger. When installed parallel with a furnace, dampers or other means used to control flow of air shall be adequate to prevent chilled air from entering furnace. If dampers are manually operated, they must be equipped with a means to prevent operation of either unit unless damper is in full-heat or full-cool position.

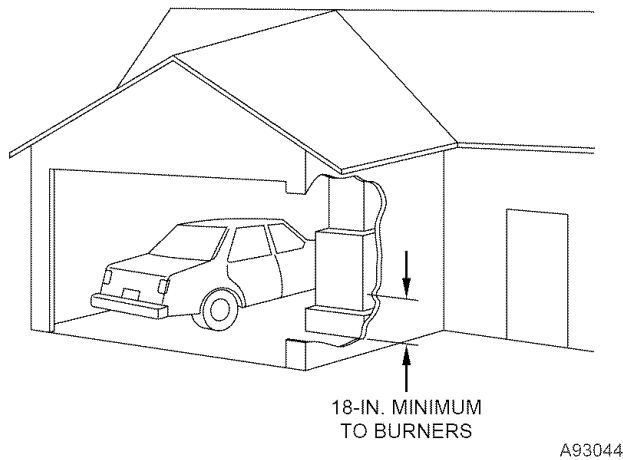

Fig. 16—Installation in a Garage

### ⚠ WARNING

#### FURNACE CORROSION HAZARD

Air for combustion must not be contaminated by halogen compounds, which include fluoride, chloride, bromide, and iodide. These elements could corrode heat exchangers and shorten furnace life. Air contaminants are found in aerosol sprays, detergents, bleaches, cleaning solvents, salts, air fresheners, and other household products.

The following types of furnace installations may require OUTDOOR AIR for combustion due to chemical exposures:

- Commercial buildings
- Buildings with indoor pools
- Laundry rooms
- Hobby or craft rooms, and
- Chemical storage areas

If air is exposed to the following substances, it should not be used for combustion air, and outdoor air may be required for combustion:

- Permanent wave solutions
- Chlorinated waxes and cleaners
- Chlorine based swimming pool chemicals
- Water softening chemicals
- De-icing salts or chemicals
- Carbon tetrachloride
- Halogen type refrigerants
- Cleaning solvents (such as perchloroethylene)
- Printing inks, paint removers, varnishes, etc.
- Hydrochloric acid
- Cements and glues
- Antistatic fabric softeners for clothes dryers
- Masonry acid washing materials

All fuel-burning equipment must be supplied with air for fuel combustion. Sufficient air **must** be provided to avoid negative pressure in the equipment room or space. A positive seal **must** be made between the furnace cabinet and the return-air duct to prevent pulling air from the burner area and from draft safeguard opening.

### ⚠ WARNING

#### CARBON MONOXIDE POISONING HAZARD

The operation of exhaust fans, kitchen ventilation fans, clothes dryers, attic exhaust fans or fireplaces could create a **NEGATIVE PRESSURE CONDITION** at the furnace. Make-up air **MUST** be provided for the ventilation devices, in addition to that required by the furnace. Refer to the Carbon Monoxide Poisoning Hazard warning in the venting section of these instructions to determine if an adequate amount of make-up air is available.

The requirements for combustion and ventilation air depend upon whether or not the furnace is located in a space having a volume of at least 50 cubic feet per 1,000 Btuh input rating for all gas appliances installed in the space.

- Spaces having less than 50 cubic feet per 1,000 Btuh require the **OUTDOOR COMBUSTION AIR METHOD**.
- Spaces having at least 50 cubic feet per 1,000 Btuh may use the **INDOOR COMBUSTION AIR, STANDARD** or **KNOWN-AIR INFILTRATION METHOD**.

#### Outdoor Combustion Air Method

1. Provide the space with sufficient air for proper combustion, ventilation, and dilution of flue gases using permanent horizontal or vertical duct(s) or opening(s) directly communicating with the outdoors or spaces that freely communicate with the outdoors.
2. Fig. 17 illustrates how to provide **TWO OUTDOOR OPENINGS**, one inlet and one outlet combustion and ventilation air openings to the outdoors.
  - a. One opening **MUST** commence within 12" (300 mm) of the ceiling and the second opening **MUST** commence within 12" (300 mm) of the floor.
  - b. Size openings and ducts per Fig. 17 and Table 1.
  - c. **TWO HORIZONTAL DUCTS** require 1 square inch of free area per 2,000 Btuh (1,100 mm<sup>2</sup>/kW) of combined input for all gas appliances in the space per Fig. 17 and Table 1.
  - d. **TWO OPENINGS OR VERTICAL DUCTS** require 1 square inch of free area per 4,000 Btuh (550 mm<sup>2</sup>/kW) for combined input of all gas appliances in the space per Fig. 17 and Table 1.
3. **ONE OUTDOOR OPENING** requires:
  - a. 1 square inch of free area per 3,000 Btuh (734 mm<sup>2</sup>/kW) for combined input of all gas appliances in the space per Table 1 and
  - b. Not less than the sum of the areas of all vent connectors in the space.

The opening shall commence within 12" (300 mm) of the ceiling. Appliances in the space shall have clearances of at least 1" (25 mm) from the sides and back and 6" (150 mm) from the front. The opening shall directly communicate with the outdoors or shall communicate through a vertical or horizontal duct to the outdoors or spaces (crawl or attic) that freely communicate with the outdoors.

#### Indoor Combustion Air © NFPA & AGA

#### Standard and Known-Air-Infiltration Rate Methods

Indoor air is permitted for combustion, ventilation, and dilution, if the **Standard** or **Known-Air-Infiltration** Method is used.

**Table 1—Minimum Free Area Required for Each Combustion Air Opening or Duct to Outdoors**

FURNACE INPUT (BTUH)	TWO HORIZONTAL DUCTS (1 SQ. IN./2,000 BTUH) (1,100 SQ. MM/KW)		SINGLE DUCT OR OPENING (1 SQ. IN./3,000 BTUH) (734 SQ. MM/KW)		TWO OPENINGS OR VERTICAL DUCTS (1 SQ. IN./4,000 BTUH) (550 SQ. MM/KW)	
	Free Area of Opening and Duct (Sq. In.)	Round Duct (in. Dia)	Free Area of Opening and Duct (sq In.)	Round Duct (in. Dia)	Free Area of Opening and Duct (Sq In.)	Round Duct (in. Dia)
44,000	22	6	14.7	5	11	4
66,000	33	7	22	6	16.5	5
88,000	44	8	29.3	7	22	6
110,000	55	9	36.7	7	27.5	6
132,000	66	10	44	8	33	7
154,000	77	10	51.3	9	38.5	8

**EXAMPLES: Determining Free Area**

FURNACE	+	WATER HEATER	=	TOTAL INPUT	=	Result
110,000	+	30,000	=	(140,000 divided by 4,000)	=	35.0 Sq. In. for each two Vertical Ducts or Openings
66,000	+	40,000	=	(106,000 divided by 3,000)	=	35.3 Sq. In. for a Single Duct or Opening
88,000	+	30,000	=	(118,000 divided by 2,000)	=	59.0 Sq. In. for each of two Horizontal Ducts

**Table 2—Minimum Space Volumes for 100% Combustion, Ventilation and Dilution Air from Outdoors**

ACH	OTHER THAN FAN-ASSISTED TOTAL (1,000'S BTUH GAS INPUT RATE)			FAN-ASSISTED TOTAL (1,000'S BTUH GAS INPUT RATE)					
	30	40	50	44	66	88	110	132	154
	Space Volume (ft <sup>3</sup> )								
0.60	1,050	1,400	1,750	1,100	1,650	2,200	2,750	3,300	3,850
0.50	1,260	1,680	2,100	1,320	1,980	2,640	3,300	3,960	4,620
0.40	1,575	2,100	2,625	1,650	2,475	3,300	4,125	4,950	5,775
0.30	2,100	2,800	3,500	2,200	3,300	4,400	5,500	6,600	7,700
0.20	3,150	4,200	5,250	3,300	4,950	6,600	8,250	9,900	11,550
0.10	6,300	8,400	10,500	6,600	9,900	13,200	16,500	19,800	23,100
0.00	NP	NP	NP	NP	NP	NP	NP	NP	NP

**⚠ WARNING**

**CARBON MONOXIDE POISONING HAZARD**

Failure to supply outdoor air via grilles or ducts could result in death and/or personal injury. Many homes require air to be supplied from outdoors for furnace combustion, ventilation, and dilution of flue gases. The furnace combustion air supply must be provided in accordance with this instruction manual.

Table 2—Minimum Space Volumes were determined by using the following equations from the *National Fuel Gas Code ANSI Z223.1-2002/NFPA 54-2002, 8.3.2.2*:

1. For **other than fan-assisted appliances**, such as a draft hood-equipped water heater:

$$\text{Volume}_{\text{Other}} = \frac{21\text{ft}^3}{\text{ACH}} \left( \frac{I_{\text{other}}}{1000 \text{ Btu/hr}} \right)$$

A04002

2. For **fan-assisted appliances** such as this furnace:

$$\text{Volume}_{\text{Fan}} = \frac{15\text{ft}^3}{\text{ACH}} \left( \frac{I_{\text{fan}}}{1000 \text{ Btu/hr}} \right)$$

A04003

If:

$I_{\text{other}}$  = combined input of all **other than fan-assisted appliances** in Btu/hr

$I_{\text{fan}}$  = combined input of all **fan-assisted appliances** in Btu/hr

ACH = air changes per hour (ACH shall not exceed 0.60.)

The following requirements apply to the **Standard Method** and to the **Known Air Infiltration Rate Method**.

The **Standard Method**:

1. The space has no less volume than 50 cubic feet per 1,000 Btu/h of the maximum input ratings for all gas appliances installed in the space and
2. The air infiltration rate is not known to be less than 0.40 air changes per hour (ACH).

The **Known Air Infiltration Rate Method** shall be used, if the infiltration rate is known to be:

1. Less than 0.40 ACH and
2. Equal to or greater than 0.10 ACH

Infiltration rates greater than 0.60 ACH shall not be used. The minimum required volume of the space varies with the number of ACH and shall be determined per Table 2 or Equations 1 and 2. Determine the minimum required volume for each appliance in the space and add the volumes together to get the total minimum required volume for the space.



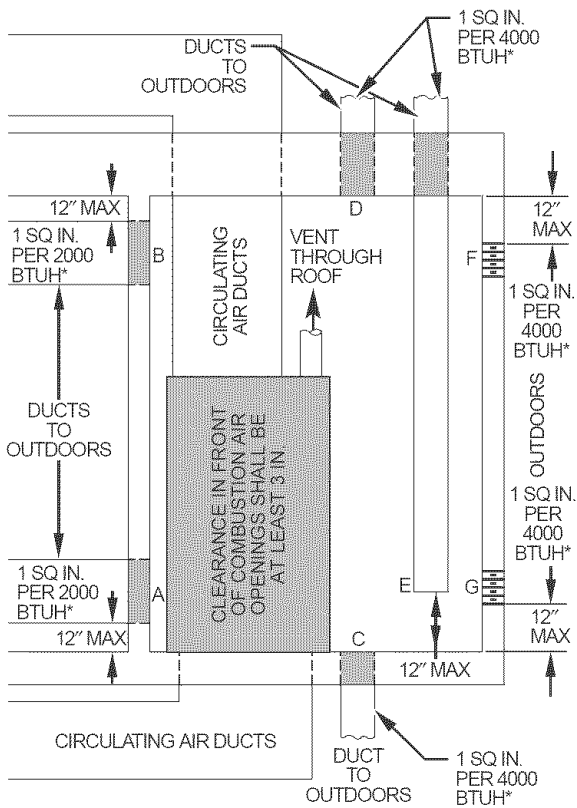

\*Minimum dimensions of 3 in.

**NOTE:** Use any of the following combinations of openings:  
A & B C & D D & E F & G

**Fig. 17—Air for Combustion, Ventilation, and Dilution for Outdoors**

A03174

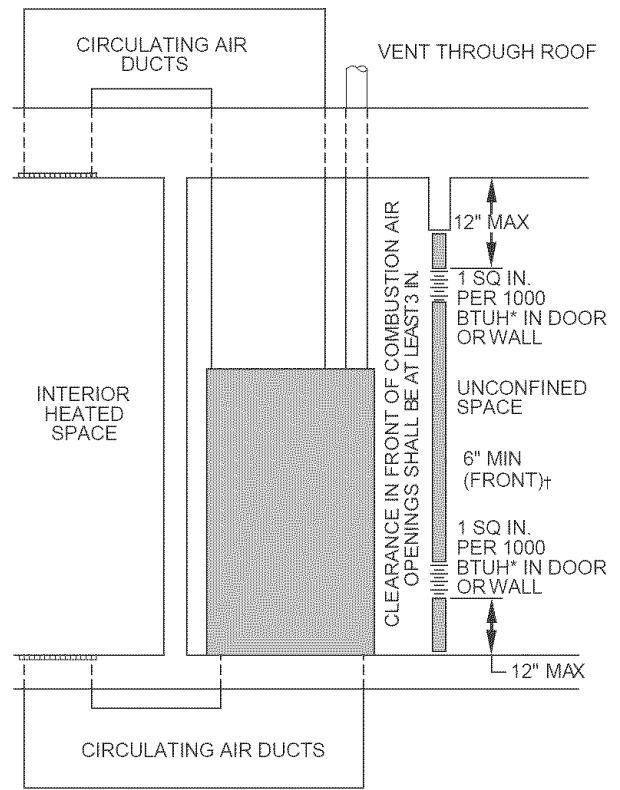

\* Minimum opening size is 100 sq in. with minimum dimensions of 3 in.

† Minimum of 3 in. when type-B1 vent is used.

**Fig. 18—Air for Combustion, Ventilation, and Dilution from Indoors**

A03175

1. Adjoining rooms can be considered part of a space if:
  - a. There are no closable doors between rooms.
  - b. Combining spaces on same floor level. Each opening shall have free area of at least  $1 \text{ in.}^2/1,000 \text{ Btuh}$  ( $2,000 \text{ mm}^2/\text{kW}$ ) of the total input rating of all gas appliances in the space, but not less than  $100 \text{ in.}^2$  ( $0.06 \text{ m}^2$ ). One opening shall commence within 12" (300 mm) of the ceiling and the second opening shall commence within 12" (300 mm) of the floor. The minimum dimension of air openings shall be at least 3 in. (80 mm). (See Fig. 18.)
  - c. Combining space on different floor levels. The volumes of spaces on different floor levels shall be considered as communicating spaces if connected by one or more permanent openings in doors or floors having free area of at least  $2 \text{ in.}^2/1,000 \text{ Btuh}$  ( $4,400 \text{ mm}^2/\text{kW}$ ) of total input rating of all gas appliances.
2. An attic or crawlspace may be considered a space that freely communicates with the outdoors provided there are adequate permanent ventilation openings directly to outdoors having free area of at least  $1 \text{ in.}^2/4,000 \text{ Btuh}$  of total input rating for all gas appliances in the space.
3. In spaces that use the **Indoor Combustion Air Method**, infiltration should be adequate to provide air for combustion, permanent ventilation and dilution of flue gases. However, in buildings with unusually tight construction, additional air **MUST** be provided using the methods described in the **Outdoor Combustion Air Method** section.

Unusually tight construction is defined as Construction with:

- a. Walls and ceilings exposed to the outdoors have a continuous, sealed vapor barrier. Openings are gasketed or sealed and
- b. Doors and openable windows are weatherstripped and
- c. Other openings are caulked or sealed. These include joints around window and door frames, between sole plates and floors, between wall-ceiling joints, between wall panels, at penetrations for plumbing, electrical and gas lines, etc.

**NOTE:** In determining the free area of an opening, the blocking effect of the louvers, grilles, and screens must be considered. If the free area of a louver or grille design is unknown, it may be assumed that wood louvers have a 20 percent free area, and metal louvers or grilles have a 60 percent free area. Screens, when used, must not be smaller than 1/4-in. mesh. Louvers and grilles must be constructed so they cannot be closed.

When combustion air ducts are used, they must be of the same cross sectional area as the free area of the openings to which they connect. The minimum dimension of ducts must not be less than 3 in. (80mm).

**Combination of Indoor and Outdoor Air**

1. Indoor openings shall comply with the **Indoor Combustion Air Method** below and,
2. Outdoor openings shall be located as required in the **Outdoor Combustion Air Method** mentioned previously and,

3. Outdoor openings shall be sized as follows:
  - a. Calculate the Ratio of all Indoor Space volume divided by required volume for **Indoor Combustion Air Method** below.
  - b. Outdoor opening size reduction **Factor** is 1 minus the **Ratio** in a. above.
  - c. Minimum size of Outdoor openings shall be the size required in **Outdoor Combustion Air Method** above multiplied by reduction **Factor** in b. above. The minimum dimension of air openings shall be not less than 3 in. (80 mm).

### INSTALLATION

#### Step 1—Leveling Legs (If Desired)

When furnace is used in upflow position with side inlet(s), leveling legs may be desired. (See Fig. 19.) Install field-supplied, corrosion-resistant 5/16-in. machine bolts and nuts.

**NOTE:** The maximum length of bolt should not exceed 1-1/2 in.

1. Position furnace on its back. Locate and drill a 5/16-in. diameter hole in each bottom corner of furnace. (See Fig. 19.) Holes in bottom closure panel may be used as guide locations.
2. For each hole, install nut on bolt and then install bolt and nut in hole. (Install flat washer if desired.)
3. Install another nut on other side of furnace base. (Install flat washer if desired.)
4. Adjust outside nut to provide desired height, and tighten inside nut to secure arrangement.

**NOTE:** Bottom closure must be used when leveling legs are used. See Bottom Closure Panel section.

#### Step 2—Installation in Upflow and Downflow Applications

**NOTE:** For downflow applications, this furnace is approved for use on combustible flooring when special base (available from manufacturer) Part No. KGASB0201ALL is used. Special base is not required when this furnace is installed on manufacturer's Coil Assembly Part No. CD5 or CK5, or Coil Box Part No. KCAKC is used.

1. Determine application being installed from Table 3.
2. Construct hole in floor per dimensions specified in Table 3 and Fig. 20.

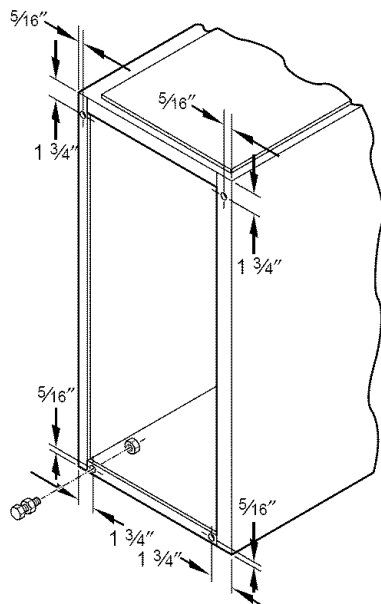

Fig. 19—Leveling Legs

A89014

3. Construct plenum to dimensions specified in Table 1 and Fig. 20.
4. If downflow subbase (KGASB) is used, install as shown in Fig. 21.  
If Coil Assembly Part No. CD5 or CK5 or Coil Box Part No. KCAKC is used, install as shown in Fig. 22.

**NOTE:** Remove furnace perforated, discharge duct flanges when they interfere with mating flanges on coil on downflow subbase. To remove furnace perforated, discharge duct flange, use wide duct pliers or duct flange tool to bend flange back and forth until it breaks off. Be careful of sharp edges. (See Fig. 23.)

### ⚠ WARNING

#### UNIT MAY NOT OPERATE

Failure to follow this caution could result in intermittent unit operation.

Do not bend duct flanges inward as shown in Fig. 23. This will affect airflow across heat exchangers and may cause limit cycling or premature heat exchanger failure. Remove duct flange completely or bend it inward a minimum of 210° as shown in Fig. 23.

#### Step 3—Installation in Horizontal Applications

### ⚠ CAUTION

#### UNIT MAY NOT OPERATE

Failure to follow this caution may result in intermittent unit operation.

The entire length of furnace **MUST** be supported when furnace is used in a horizontal position to ensure proper draining. When suspended, bottom brace supports sides and center blower shelf. When unit is supported from the ground, blocks or pad should support sides and center blower shelf area.

These furnaces can be installed horizontally in either horizontal left or right discharge position. In a crawlspace, furnace can either be hung from floor joist or installed on suitable blocks or pad. Furnace can be suspended from each corner by hanger bolts and angle iron supports. (See Fig. 24.) Cut hanger bolts (4 each 3/8-in. all-thread rod) to desired length. Use 1 X 3/8-in. flat washers, 3/8-in. lockwashers, and 3/8-in. nuts on hanger rods as shown in Fig. 24. Dimples are provided for hole locations. (See Fig. 2.)

#### Step 4—Air Ducts

##### GENERAL REQUIREMENTS

The duct system should be designed and sized according to accepted national standards such as those published by: Air Conditioning Contractors Association (ACCA), Sheet Metal and Air Conditioning Contractors National Association (SMACNA) or American Society of Heating, Refrigerating and Air Conditioning Engineers (ASHRAE) or consult *The Air Systems Design Guidelines* reference tables available from your local distributor. The duct system should be sized to handle the required system design CFM at the design static pressure.

When a furnace is installed so that the supply ducts carry air circulated by the furnace to areas outside the space containing the furnace, the return air shall also be handled by a duct(s) sealed to the furnace casing and terminating outside the space containing the furnace.

Secure ductwork with proper fasteners for type of ductwork used. Seal supply- and return-duct connections to furnace with code approved tape or duct sealer.

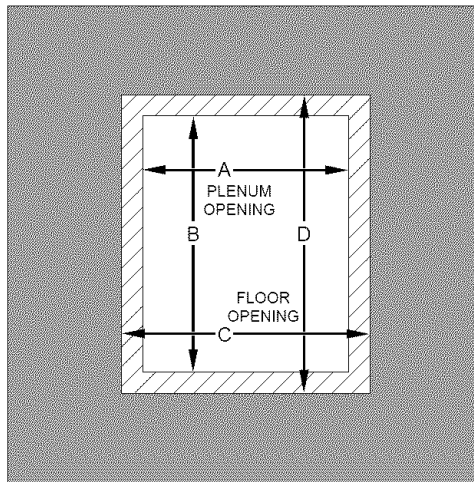

A96283

Fig. 20—Floor and Plenum Opening Dimensions

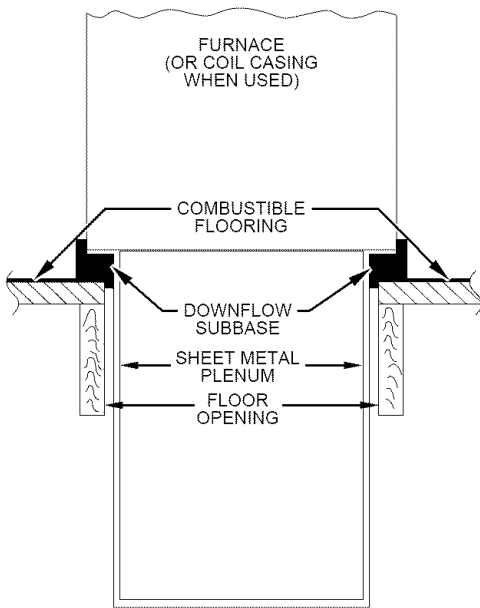

A96285

Fig. 21—Furnace, Plenum, and Subbase Installed on a Combustible Floor

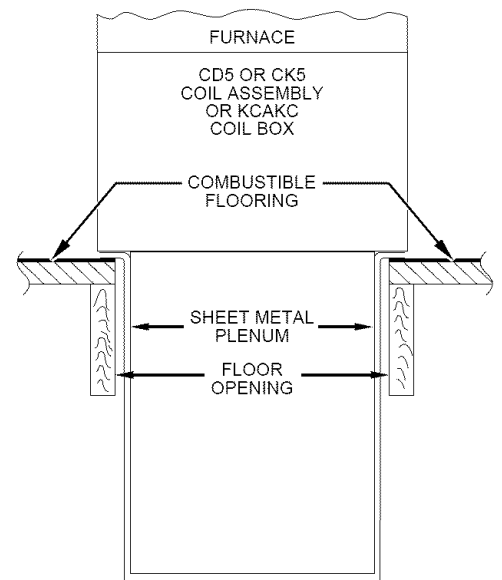

A96284

Fig. 22—Furnace, Plenum, and Coil Assembly or Coil Box Installed on a Combustible Floor

Table 3—Opening Dimensions (In.)

FURNACE CASING WIDTH	APPLICATION	PLENUM OPENING		FLOOR OPENING	
		A	B	C	D
17-1/2	Upflow Applications	16	24-1/8	16-5/8	24-3/4
	Downflow Applications on Non-Combustible Flooring	15-7/8	19	16-1/2	19-5/8
	Downflow Applications on Combustible Flooring Using KGASB Subbase Furnace with or without CD5 or CK5 Coil Assembly or KCAKC Coil Box	15-1/8	19	16-3/4	20-3/8
	Downflow Applications on Combustible Flooring NOT Using KGASB Subbase Furnace with CD5 or CK5 Coil Assembly or KCAKC Coil Box	15-1/2	19	16-1/2	20
21	Upflow Applications	19-1/2	24-1/8	20-1/8	24-3/4
	Downflow Applications on Non-Combustible Flooring	19-3/8	19	20	19-5/8
	Downflow Applications on Combustible Flooring Using KGASB Subbase Furnace with or without CD5 or CK5 Coil Assembly or KCAKC Coil Box	18-5/8	19	20-1/4	20-3/8
	Downflow Applications on Combustible Flooring NOT Using KGASB Subbase Furnace with CD5 or CK5 Coil Assembly or KCAKC Coil Box	19	19	20	20
24-1/2	Upflow Applications	23	24-1/8	23-5/8	24-3/4
	Downflow Applications on Non-Combustible Flooring	22-7/8	19	23-1/2	19-5/8
	Downflow Applications on Combustible Flooring Using KGASB Subbase Furnace with or without CD5 or CK5 Coil Assembly or KCAKC Coil Box	22-1/8	19	23-3/4	20-3/8
	Downflow Applications on Combustible Flooring NOT Using KGASB Subbase Furnace with CD5 or CK5 Coil Assembly or KCAKC Coil Box	22-1/2	19	23-1/2	20

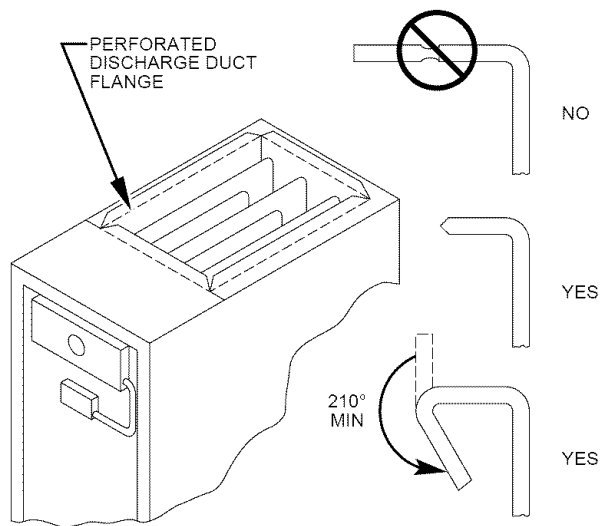

Fig. 23—Duct Flanges

A93029

Flexible connections should be used between ductwork and furnace to prevent transmission of vibration. Ductwork passing through unconditioned space should be insulated to enhance system performance. When air conditioning is used, a vapor barrier is recommended.

Maintain a 1-in. clearance from combustible materials to supply air ductwork for a distance of 36 in. horizontally from the furnace. See NFPA 90B or local code for further requirements.

For a furnace not equipped with a cooling coil, the outlet duct shall be provided with a removable access panel. This opening shall be accessible when the furnace is installed and shall be of such a size that the heat exchanger can be viewed for possible openings using light assistance or a probe can be inserted for sampling the air stream. The cover attachment shall prevent leaks.

#### DUCTWORK ACOUSTICAL TREATMENT

Metal duct systems that do not have a 90 degree elbow and 10 ft of main duct to the first branch take-off may require internal acoustical lining. As an alternative, fibrous ductwork may be used if constructed and installed in accordance with the latest edition of SMACNA construction standard on fibrous glass ducts. Both acoustical lining and fibrous ductwork shall comply with NFPA 90B as tested by UL Standard 181 for Class 1 Rigid air ducts.

#### SUPPLY AIR CONNECTIONS

##### Upflow Furnaces

Connect supply-air duct to 3/4-in. flange on furnace supply-air outlet. The supply-air duct attachment must ONLY be connected to furnace supply-/outlet-air duct flanges or air conditioning coil casing (when used). DO NOT cut main furnace casing to attach supply side air duct, humidifier, or other accessories. All accessories MUST be connected external to furnace main casing.

##### Downflow Furnaces

Connect supply-air duct to supply-air opening on furnace. The supply-air duct attachment must ONLY be connected to furnace supply/outlet or air conditioning coil casing (when used), when installed on non-combustible material. When installed on combustible material, supply-air duct attachment must ONLY be connected to an accessory subbase or factory approved air conditioning coil casing. DO NOT cut main furnace casing to attach supply side air duct, humidifier, or other accessories. All accessories MUST be connected external to furnace main casing.

#### Horizontal Furnaces

Connect supply-air duct to supply air opening on furnace. The supply-air duct attachment must ONLY be connected to furnace supply/outlet or air conditioning coil casing (when used). DO NOT cut main furnace casing to attach supply side air duct, humidifier, or other accessories. All accessories MUST be connected external to furnace main casing.

#### RETURN AIR CONNECTIONS

The furnace and its return air system shall be designed and installed so that negative pressure created by the air circulating fan cannot affect another appliance's air supply or act to mix products of combustion with circulating air, and that the air circulating fan of the furnace, if installed in an enclosure communicating with another fuel-burning appliance not of the direct-vent type, shall be operable only when any door or panel covering an opening in the furnace fan compartment or in a return air plenum on ducts is in the closed position.

#### ▲ WARNING

##### FIRE HAZARD

A failure to follow this warning could result in fire, personal injury, or death.

Never connect return-air ducts to the back of the furnace. Return-air duct connections on furnace side(s) permitted in upflow applications only.

#### Upflow Furnaces

The return-air duct must be connected to bottom, sides (left or right), or a combination of bottom and side(s) of main furnace casing as shown in Fig. 2. Bypass humidifier may be attached into unused side return air portion of the furnace casing. DO NOT connect any portion of return-air duct to back of furnace casing.

#### Downflow and Horizontal Furnaces

The return-air duct must be connected to return-air opening provided as shown in Fig. 2. DO NOT cut into casing sides or back to attach any portion of return-air duct. Bypass humidifier connections should be made at ductwork or coil casing sides exterior to furnace.

#### Step 5—Filter Arrangement

#### ▲ WARNING

##### FIRE, CARBON MONOXIDE AND POISONING HAZARD

Failure to follow this warning could result in fire, personal injury, or death.

Never operate unit without a filter or with blower access panel removed.

Factory-supplied washable framed filters are shipped in blower compartment. Determine location for filter and relocate filter retaining wire if necessary. See Table 4 to determine correct filter size for desired filter location. Table 4 indicates filter size, location, and quantity shipped with this furnace. See Fig. 2 for location and size of bottom and side return-air openings.

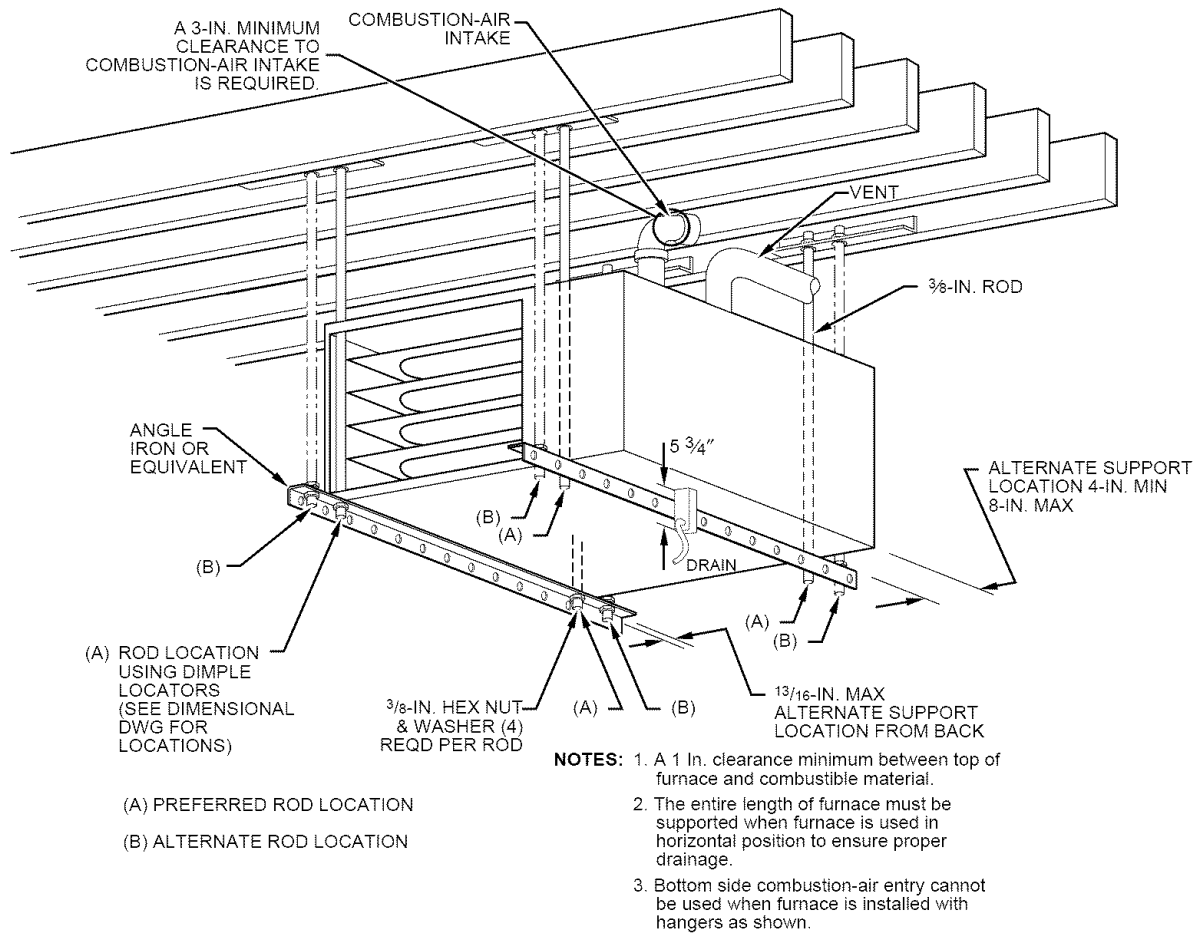

A96209

**Fig. 24—Crawlspace Horizontal Application**

**Table 4—Filter Information**

FURNACE CASING WIDTH (IN.)	FILTER SIZE (IN.)*		FILTER TYPE FRAMED
	Side Return	Bottom Return	
17-1/2	(1) 16 X 25 X 1†	(1) 16 X 25 X 1†	Cleanable
21	(1) 16 X 25 X 1	(1) 20 X 25 X 1†	Cleanable
24-1/2	(1 or 2) 16 X 25 X 1	(1) 24 X 25 X 1†	Cleanable

\* Filters can be field modified by cutting to the desired size. Alternate sizes can be ordered from your distributor or dealer.  
 † Factory-provided with furnace.

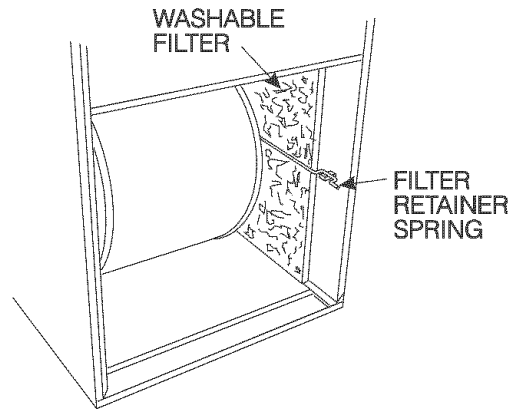

A00217

**Fig. 25—Filter Installed for Side Inlet**

Bottom return-air opening may be used with all 4 orientations. Filter may need to be cut to fit some furnace widths. Install filter as shown in Fig. 26.

**Step 6—Bottom Closure Panel**

These furnaces are shipped with bottom enclosure panel installed in bottom return-air opening. This panel **MUST** be in place when side return air is used.

To remove bottom closure panel, perform the following:

1. Tilt or raise furnace and remove 2 screws holding front filler panel. (See Fig. 27.)
2. Rotate front filler panel downward to release holding tabs.
3. Remove bottom closure panel.

**⚠ CAUTION**

**CUT HAZARD**  
 Failure to follow this caution may result in minor personal injury.  
 Use care when cutting support rods in filters to protect against flying pieces and sharp rod ends. Wear safety glasses, gloves, and appropriate protective clothing.

**⚠ CAUTION**

**UNIT MAY NOT OPERATE**  
 Failure to follow this caution may result in intermittent unit operation.  
 For airflow requirements above 1800 CFM, see Air Delivery table in Product Data literature for specific use of single side inlets. The use of both side inlets, a combination of 1 side and the bottom, or the bottom only will ensure adequate return air openings for airflow requirements above 1800 CFM.

**NOTE:** Side return-air openings can **ONLY** be used in UPFLOW configurations. Install filter(s) as shown in Fig. 25.

**17½-IN. WIDE CASINGS ONLY:**  
INSTALL FIELD-SUPPLIED FILTER FILLER STRIP UNDER FILTER.

**21-IN. WIDE CASINGS ONLY:**  
SUPPORT RODS (3)  
EXTEND ¼" ON EACH SIDE OF FILTER AND REST ON CASING FLANGE

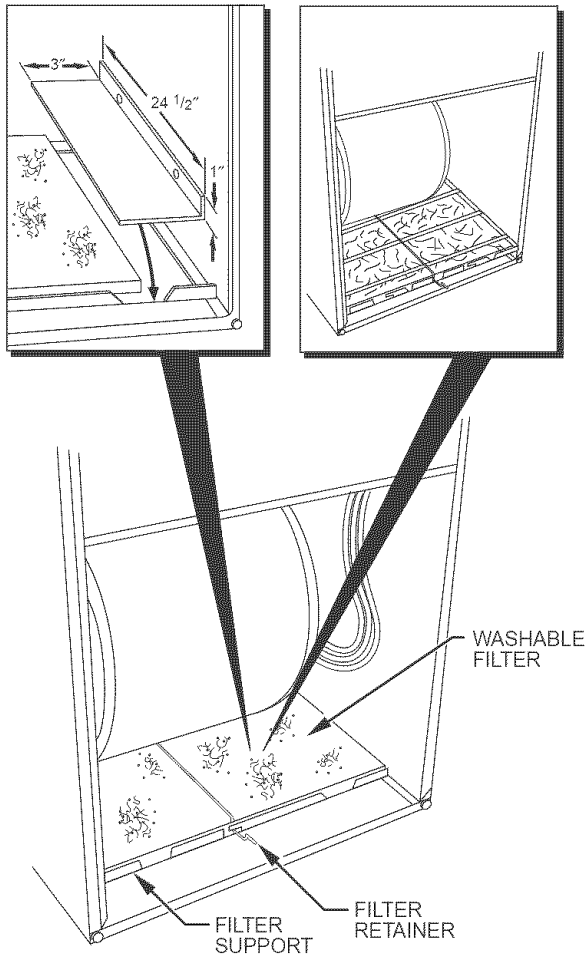

A00290

**Fig. 26—Bottom Filter Arrangement**

4. Reinstall front filler panel and screws.

**Step 7—Gas Piping**

Gas piping must be installed in accordance with national and local codes. Refer to current edition of NFGC in the United States. Canadian installations must be made in accordance with NSCNG-

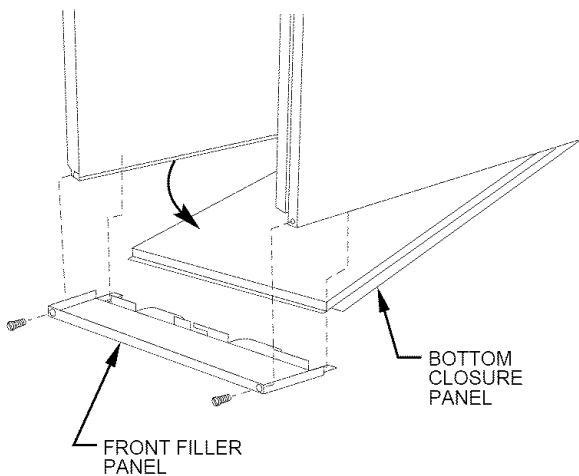

A93047

**Fig. 27—Removing Bottom Closure Panel**

PIC and all authorities having jurisdiction. Gas supply line should be a separate line running directly from meter to furnace, if possible. Refer to Table 5 for recommended gas pipe sizing. Risers must be used to connect to furnace and to meter. Support all gas piping with appropriate straps, hangers, etc. Use a minimum of 1 hanger every 6 ft. Joint compound (pipe dope) should be applied sparingly and only to male threads of joints. Pipe dope must be resistant to propane gas.

**⚠ WARNING**

**FIRE OR EXPLOSION HAZARD**

Failure to follow this warning could result in fire, explosion, personal injury, or death.

- Connect gas pipe to furnace using a backup wrench to avoid damaging gas controls.
- Gas valve shutoff switch **MUST** be facing forward or tilted upward.
- Never purge a gas line into a combustion chamber. Never test for gas leaks with an open flame. Use a commercially available soap solution made specifically for the detection of leaks to check all connections.
- Use proper length of pipe to avoid stress on gas control manifold.
- If a flexible connector is required or allowed by authority having jurisdiction, black iron pipe shall be installed at furnace gas valve and extend a minimum of 2 in. outside furnace casing.

Install a sediment trap in riser leading to furnace. Trap can be installed by connecting a tee to riser leading to furnace so straight-through section of tee is vertical. Then connect a capped nipple into lower end of tee. Capped nipple should extend below level of gas controls. Place a ground joint union between gas control manifold and manual gas shutoff valve. (See Fig. 28.)

If local codes allow the use of a flexible gas appliance connector, always use a new listed connector. Do not use a connector which has previously served another gas appliance.

**⚠ WARNING**

**FIRE OR EXPLOSION HAZARD**

Failure to follow the safety warnings exactly could result in serious injury, death or property damage.

Never test for gas leaks with an open flame. Use a commercially available soap solution made specifically for the detection of leaks to check all connections. A fire or explosion could result causing property damage, personal injury or loss of life.

An accessible manual shutoff valve **MUST** be installed external to the furnace casing and within 6 ft of furnace. A 1/8-in. NPT plugged tapping, accessible for test gauge connection, **MUST** be

**Table 5—Maximum Capacity of Pipe\***

NOMINAL IRON PIPE SIZE (IN.)	INTERNAL DIAMETER (IN.)	LENGTH OF PIPE (FT)				
		10	20	30	40	50
1/2	0.622	175	120	97	82	73
3/4	0.824	360	250	200	170	151
1	1.049	680	465	375	320	285
1-1/4	1.380	1400	950	770	660	580
1-1/2	1.610	2100	1460	1180	990	900

\* Cubic ft. of gas per hr for gas pressures of 0.5 psig (14-in. wc) or less, and a pressure drop of 0.5-in. wc (based on a 0.60 specific gravity gas). Ref: Table 12-2 NFPA 54-2002.

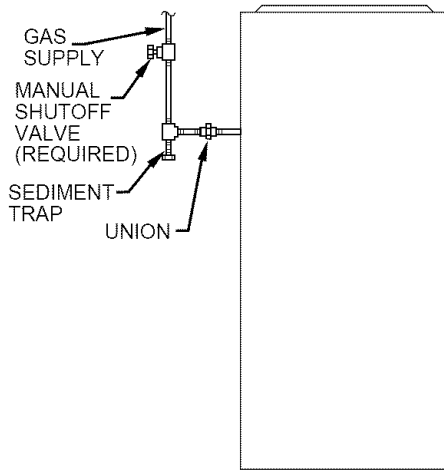

A93324

**Fig. 28—Typical Gas Pipe Arrangement**

installed immediately upstream of gas supply connection to furnace and downstream of manual shutoff valve.

**NOTE:** The gas valve inlet pressure tap connection is suitable to use as test gauge connection providing test pressure DOES NOT exceed maximum 0.5 psig (14-in. wc) stated on gas valve. (See Fig. 46.)

Piping should be pressure and leak tested in accordance with NFGC in the United States or NSCPGIC in Canada, local, and national plumbing and gas codes before the furnace has been connected. After all connections have been made, purge lines and check for leakage at furnace prior to operating furnace.

If pressure exceeds 0.5 psig (14-in. wc), gas supply pipe must be disconnected from furnace and capped before pressure test. If test pressure is equal to or less than 0.5 psig (14-in. wc), turn off electric shutoff switch located on furnace gas valve and accessible manual shutoff valve before test.

The gas supply pressure shall be within the maximum and minimum inlet supply pressures marked on the rating plate with the furnace burners ON and OFF.

### Step 8—Electrical Connections

See Fig. 30 for field wiring diagram showing typical field 115-v and 24-v wiring. Check all factory and field electrical connections for tightness.

Field-supplied wiring shall conform with the limitations of 63°F (35°C) rise.

#### ⚠ WARNING

##### ELECTRICAL SHOCK HAZARD

Failure to follow this warning could result in serious injury or death.

Blower access panel door switch opens 115-v power to control center. No component operation can occur. Do not bypass or close switch with panel removed.

#### ⚠ CAUTION

##### FURNACE MAY NOT OPERATE

Failure to follow this caution may result in furnace operation stopping and water pipes freezing during cold weather.

Furnace control must be grounded for proper operation or control will lock out. Control is grounded through green/yellow wire routed to gas valve and burner box screw.

#### 115-V WIRING

Before proceeding with electrical connections, make certain that voltage, frequency, and phase correspond to that specified on unit rating plate. Also, check to be sure that service provided by power supply is sufficient to handle load imposed by this equipment. Refer to rating plate or Table 6 for equipment electrical specifications.

Make all electrical connections in accordance with National Electrical Code (NEC) ANSI/NFPA 70-2002 and any local codes or ordinances that might apply. For Canadian installations, all electrical connections must be made in accordance with Canadian Electrical Code CSA C22.1 or authorities having jurisdiction.

Use a separate, fused branch electrical circuit containing a properly sized fuse or circuit breaker for this furnace. See Table 6 for wire size and fuse specifications. A disconnecting means must be located within sight from and readily accessible to furnace.

**Table 6—Electrical Data**

UNIT SIZE	VOLTS—HERTZ—PHASE	OPERATING VOLTAGE RANGE		MAX UNIT AMPS	UNIT AMPACITY†	MIN WIRE SIZE	MAX WIRE LENGTH (FT)‡	MAX FUSE OR CKT BKR AMPS**
		Max*	Min*					
040-08	115—60—1	127	104	6.1	8.4	14	44	15
040-12	115—60—1	127	104	7.3	10.0	14	37	15
060-08	115—60—1	127	104	6.1	8.4	14	44	15
060-12	115—60—1	127	104	7.1	9.8	14	38	15
060-16	115—60—1	127	104	9.5	12.8	14	29	15
080-12	115—60—1	127	104	7.6	10.4	14	36	15
080-16	115—60—1	127	104	10.0	13.4	14	28	15
080-20	115—60—1	127	104	14.1	18.4	12	31	20
100-16	115—60—1	127	104	10.2	13.5	14	27	15
100-20	115—60—1	127	104	14.8	19.3	12	30	20
120-20	115—60—1	127	104	14.6	19.1	12	30	20

\* Permissible limits of voltage range at which unit will operate satisfactorily.

† Unit ampacity = 125 percent of largest operating component's full load amps plus 100 percent of all other potential operating components' (EAC, humidifier, etc.) full load amps.

‡ Length shown is as measured 1 way along wire path between unit and service panel for maximum 2 percent voltage drop.

\*\* Time-delay type is recommended.

**Table 7—Approved Combustion-Air and Vent Pipe, Fitting and Cement Materials**

ASTM SPECIFICATION (MARKED ON MATERIAL)	MATERIAL	PIPE	FITTINGS	SOLVENT CEMENT AND PRIMERS	DESCRIPTION
D1527	ABS	Pipe	—	—	Schedule-40
D1785	PVC	Pipe	—	—	Schedule-40
D2235	For ABS	—	—	Solvent Cement	For ABS
D2241	PVC	Pipe	—	—	SDR-21 & SDR-26
D2466	PVC	—	Fittings	—	Schedule-40
D2468	ABS	—	Fittings	—	Schedule-40
D2564	For PVC	—	—	Solvent Cement	For PVC
D2661	ABS	Pipe	Fittings	—	DWV at Schedule-40 IPS sizes
D2665	PVC	Pipe	Fittings	—	DWV
F438	CPVC	—	Fittings	—	Schedule-40
F441	CPVC	Pipe	—	—	Schedule-40
F442	CPVC	Pipe	—	—	SDR
F493	For CPVC	—	—	Solvent Cement	For CPVC
F628	ABS	Pipe	—	—	Cellular Core DWV at Schedule-40 IPS sizes
F656	For PVC	—	—	Primer	For PVC
F891	PVC	Pipe	—	—	Cellular Core Schedule-40 & DWV

**NOTE:** Proper polarity must be maintained for 115-v wiring. If polarity is incorrect, control center fault code indicator light will flash rapidly and furnace will NOT operate.

**⚠ WARNING**

**FIRE HAZARD**  
 Failure to follow this warning could result in serious injury, death, or property damage.  
 Do not connect aluminum wire between disconnect switch and furnace. Use only copper wire. (See Fig. 29.)

**⚠ WARNING**

**ELECTRICAL SHOCK AND FIRE HAZARD**  
 Failure to follow this warning may result in serious injury, death, or property damage.  
 If manual disconnect switch is to be mounted on furnace, select a location where a drill or fastener will not contact electrical or gas components.

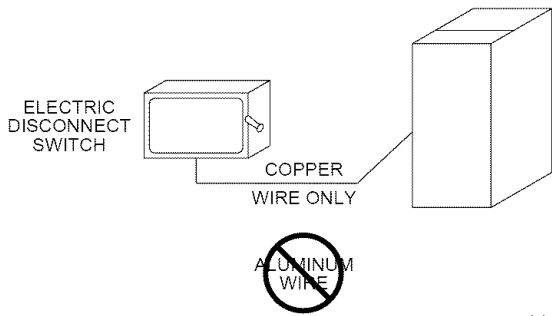

A93033

**Fig. 29—Disconnect Switch and Furnace**

**⚠ WARNING**

**ELECTRICAL SHOCK AND FIRE HAZARD**  
 Failure to follow this warning could result in serious injury, death, or property damage.  
 The cabinet **MUST** have an uninterrupted or unbroken ground according to NEC ANSI/NFPA 70-2002 and Canadian Electrical Code CSA C22.1 or local codes to minimize personal injury if an electrical fault should occur. This may consist of electrical wire or conduit approved for electrical ground when installed in accordance with existing electrical codes. Do not use gas piping as an electrical ground.

**24-V WIRING**

Make field 24-v thermostat connections at 24-v terminal block on furnace control. For proper cooling operation, Y wire from thermostat **MUST** be connected to Y terminal on furnace control, as shown in Fig. 30. The 24-v terminal block is marked for easy connection of field wiring. (See Fig. 32.) The 24-v circuit contains a 3-amp, automotive-type fuse located on furnace control. (See Fig. 33.) Any electrical shorts of 24-v wiring during installation, service, or maintenance may cause fuse to blow. If fuse replacement is required, use only a fuse of identical size (3 amp) and type. The control will flash code 24 when fuse needs replacement.

**NOTE:** Use AWG No. 18 color-coded copper thermostat wire for lengths up to 100 ft. For wire lengths over 100 ft, use AWG No. 16 wire.

**ACCESSORIES**

1. Electronic Air Cleaner (EAC)

Two quick-connect terminals marked EAC-1 and EAC-2 are provided for EAC connection. (See Fig. 33.) These terminals are energized with 115v (1.0-amp maximum) during blower motor operation.

**NOTE:** DO NOT connect furnace control HUM terminal to HUM (humidifier) terminal on Thermidistat™, Zone Controller or similar device. See Thermidistat™, Zone Controller, thermostat, or controller manufacturer's instructions for proper connection.

**J-Box Relocation**

1. Remove 2 screws holding auxiliary J-box. (See Fig. 31.)
2. Rotate J-box 180° and attach box to left side, using holes provided.





**Table 8—Maximum Allowable Vent Pipe Length (Ft)**

ALTITUDE	UNIT SIZE	VENT PIPE DIAMETER (IN.)	NUMBER OF 90° ELBOWS						
			1	2	3	4	5	6	
0 to 2000	040-08 040-12	1	5	NA	NA	NA	NA	NA	
		1-1/2	70	70	65	60	60	55	
		2	70	70	70	70	70	70	
	060-08 036060 060-16	1-1/2	20	15	10	5	NA	NA	
		2	70	70	70	70	70	70	
		1-1/2	10	NA	NA	NA	NA	NA	
	080-12 080-16 080-20	2	55	50	35	30	30	20	
		2-1/2	70	70	70	70	70	70	
		2	5	NA	NA	NA	NA	NA	
	100-16 100-20	2-1/2	40	30	20	20	10	NA	
		3	70	70	70	70	70	70	
		2-1/2	10	NA	NA	NA	NA	NA	
120-20	3*	70	70	70	70	70	70		
<hr/>									
ALTITUDE	UNIT SIZE	VENT PIPE DIAMETER (IN.)	NUMBER OF 90° ELBOWS						
			1	2	3	4	5	6	
2001 to 3000	040-08 040-12	1-1/2	67	62	57	52	52	47	
		2	70	70	70	70	70	70	
	060-08 036060 060-16	1-1/2	17	12	7	NA	NA	NA	
		2	70	67	66	61	61	61	
	080-12 080-16 080-20	2	49	44	30	25	25	15	
		2-1/2	70	70	70	70	70	70	
	100-16 100-20	2-1/2	35	26	16	16	6	NA	
		3	70	70	70	70	66	61	
	120-20	3*	63	62	62	61	61	61	
	<hr/>								
	ALTITUDE	UNIT SIZE	VENT PIPE DIAMETER (IN.)	NUMBER OF 90° ELBOWS					
				1	2	3	4	5	6
3001 to 4000	040-08 040-12	1-1/2	64	59	54	49	48	43	
		2	70	70	70	70	70	70	
	060-08 036060 060-16	1-1/2	16	11	6	NA	NA	NA	
		2	68	63	62	57	57	56	
	080-12 080-16 080-20	2	46	41	28	23	22	13	
		2-1/2	70	70	70	70	70	70	
	100-16 100-20	2-1/2	33	24	15	14	5	NA	
		3	70	70	70	66	61	56	
	120-20	3*	59	59	58	57	57	56	
	<hr/>								
	ALTITUDE	UNIT SIZE	VENT PIPE DIAMETER (IN.)	NUMBER OF 90° ELBOWS					
				1	2	3	4	5	6
4001 to 5000†	040-08 040-12	1-1/2	60	55	50	45	44	39	
		2	70	70	70	70	70	70	
	060-08 036060 060-16	1-1/2	15	10	5	NA	NA	NA	
		2	64	59	58	53	52	52	
	080-12 080-16 080-20	2	44	39	26	21	20	11	
		2-1/2	70	70	70	70	70	70	
	100-16 100-20	2-1/2	31	22	13	12	NA	NA	
		3	70	70	67	62	57	52	
	120-20	3*	56	55	54	53	52	52	

\* Wide radius elbow.

† Vent sizing for Canadian installations over 4500 ft (1370 m) above sea level are subject to acceptance by the local authorities having jurisdiction.

NA—Not Allowed; pressure switch will not make.

**NOTES:**

1. Do not use pipe size greater than those specified in table or incomplete combustion, flame disturbance, or flame sense lockout may occur.
2. Assume two 45° elbows equal one 90° elbow. Long radius elbows are desirable and may be required in some cases.
3. Elbows and pipe sections within the furnace casing and at the vent termination should not be included in vent length or elbow count.
4. The minimum pipe length is 5 ft for all applications.

→ **Table 8—Maximum Allowable Vent Pipe Length (Ft) Continued**

ALTITUDE	UNIT SIZE	VENT PIPE DIAMETER (IN.)	NUMBER OF 90° ELBOWS					
			1	2	3	4	5	6
5001 to 6000†	040-08 040-12	1-1/2	57	52	47	42	40	35
		2	70	70	70	70	70	70
	060-08 036060 060-16	1-1/2	14	9	NA	NA	NA	NA
		2	60	55	54	49	48	47
	080-12 080-16 080-20	2	41	36	23	18	17	8
		2-1/2	70	70	70	70	70	70
	100-16 100-20	2-1/2	29	21	12	11	NA	NA
		3	70	67	62	57	52	47
120-20	3*	53	52	50	49	48	47	
ALTITUDE	UNIT SIZE	VENT PIPE DIAMETER (IN.)	NUMBER OF 90° ELBOWS					
6001 to 7000†	040-08 040-12	1-1/2	53	48	43	38	37	32
		2	70	70	68	67	66	64
	060-08 036060 060-16	1-1/2	13	8	NA	NA	NA	NA
		2	57	52	50	45	44	43
	080-12 080-16 080-20	2	38	33	21	16	15	6
		2-1/2	70	70	68	67	66	64
	100-16 100-20	2-1/2	27	19	10	9	NA	NA
		3	68	63	58	53	48	43
120-20	3*	49	48	47	45	44	43	
ALTITUDE	UNIT SIZE	VENT PIPE DIAMETER (IN.)	NUMBER OF 90° ELBOWS					
7001 to 8000†	040-08 040-12	1-1/2	49	44	39	34	33	28
		2	66	65	63	62	60	59
	060-08 036060 060-16	1-1/2	12	7	NA	NA	NA	NA
		2	53	48	46	41	40	38
	080-12 080-16 080-20	2	36	31	19	14	12	NA
		2-1/2	66	65	63	62	60	59
	100-16 100-20	2-1/2	25	17	8	7	NA	NA
		3	63	58	53	48	43	38
120-20	3*	46	44	43	41	40	38	
ALTITUDE	UNIT SIZE	VENT PIPE DIAMETER (IN.)	NUMBER OF 90° ELBOWS					
8001 to 9000†	040-08 040-12	1-1/2	46	41	36	31	29	24
		2	62	60	58	56	55	53
	060-08 036060 060-16	1-1/2	11	6	NA	NA	NA	NA
		2	49	44	42	37	35	34
	080-12 080-16 080-20	2	33	28	17	12	10	NA
		2-1/2	62	60	58	56	55	53
	100-16 100-20	2-1/2	23	15	7	5	NA	NA
		3	59	54	49	44	39	34
120-20	3*	43	41	39	37	35	34	

\* Wide radius elbow.

† Vent sizing for Canadian installations over 4500 ft (1370 m) above sea level are subject to acceptance by the local authorities having jurisdiction.

NA—Not Allowed; pressure switch will not make.

**NOTES:**

1. Do not use pipe size greater than those specified in table or incomplete combustion, flame disturbance, or flame sense lockout may occur.
2. Assume two 45° elbows equal one 90° elbow. Long radius elbows are desirable and may be required in some cases. 3. Elbows and pipe sections within the furnace casing and at the vent termination should not be included in vent length or elbow count.
4. The minimum pipe length is 5 ft for all applications.

Table 8—Maximum Allowable Vent Pipe Length (Ft) Continued

ALTITUDE	UNIT SIZE	VENT PIPE DIAMETER (IN.)	NUMBER OF 90° ELBOWS					
			1	2	3	4	5	6
9001 to 10,000†	040-08	1-1/2	42	37	32	27	25	20
	040-12	2	57	55	53	51	49	47
	060-08	2	45	40	38	33	31	29
	036060							
	060-16							
	080-12	2	30	25	14	9	7	NA
	080-16							
	080-20							
	100-16	2-1/2	21	13	5	NA	NA	NA
	100-20							
	100-20	3	54	49	44	39	34	29
	120-20	3*	39	37	35	33	31	29

\* Wide radius elbow.  
 † Vent sizing for Canadian installations over 4500 ft (1370 m) above sea level are subject to acceptance by the local authorities having jurisdiction.  
 NA—Not Allowed; pressure switch will not make.

- NOTES:**
1. Do not use pipe size greater than those specified in table or incomplete combustion, flame disturbance, or flame sense lockout may occur.
  2. Assume two 45° elbows equal one 90° elbow. Long radius elbows are desirable and may be required in some cases.
  3. Elbows and pipe sections within the furnace casing and at the vent termination should not be included in vent length or elbow count.
  4. The minimum pipe length is 5 ft for all applications.

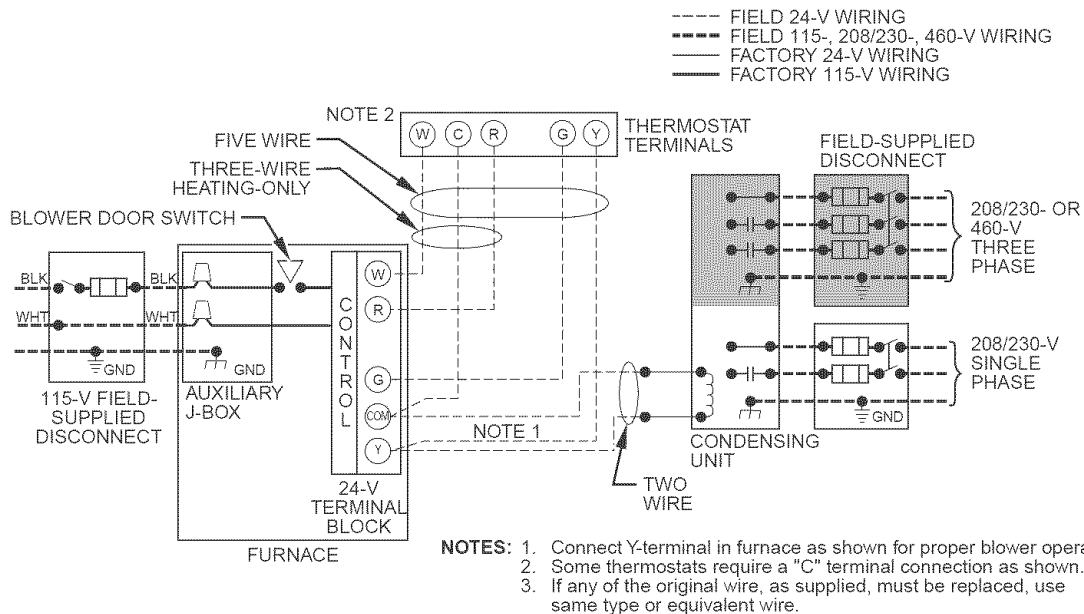

Fig. 30—Typical Heating and Cooling Application Wiring Diagram

A02174

2. Humidifier (HUM)

A quick-connect terminal (HUM) and screw terminal (COM 24-v) are provided for 24-v humidifier connection. (See Fig. 33.) HUM terminal is energized with 24v (0.5-amp maximum) when gas valve is energized.

**NOTE:** A field-supplied, 115-v controlled relay connected to EAC terminals may be added if humidifier operation is desired during blower operation.

**Step 9—Venting**

The 58MSA Furnaces require a dedicated, (one 58MSA furnace only) sealed vent system. All air for combustion is taken from the area adjacent to furnace, and all flue gases are discharged to outdoor atmosphere. The venting system shall be installed in accordance to these instructions.

REMOVAL OF EXISTING FURNACES FROM COMMON VENT SYSTEMS

When an existing Category I furnace is removed or replaced, the original venting system may no longer be sized to properly vent the remaining attached appliances. An improperly sized Category I venting system could cause the formation of condensate in the furnace and vent, leakage of condensate and combustion products, spillage of combustion products into the living space, etc.

## ⚠ WARNING

### CARBON MONOXIDE POISONING HAZARD

Failure to follow the steps outlined below for each appliance connected to the venting system being placed into operation could result in carbon monoxide poisoning or death.

The following steps shall be followed for each appliance connected to the venting system being placed into operation, while all other appliances connected to the venting system are not in operation:

1. Seal any unused openings in venting system.
2. Inspect the venting system for proper size and horizontal pitch, as required in the National Fuel Gas Code, ANSI Z223.1-2002/NFPA 54-2002 or the CSA B149.1, Natural Gas and Propane Installation Code and these instructions. Determine that there is no blockage or restriction, leakage, corrosion and other deficiencies, which could cause an unsafe condition.
3. As far as practical, close all building doors and windows and all doors between the space in which the appliance(s) connected to the venting system are located and other spaces of the building.
4. Close fireplace dampers.
5. Turn on clothes dryers and any appliance not connected to the venting system. Turn on any exhaust fans, such as range hoods and bathroom exhausts, so they are operating at maximum speed. Do not operate a summer exhaust fan.
6. Follow the lighting instructions. Place the appliance being inspected into operation. Adjust the thermostat so appliance is operating continuously.
7. Test for spillage from draft hood equipped appliances at the draft hood relief opening after 5 minutes of main burner operation. Use the flame of a match or candle.
8. If improper venting is observed during any of the above tests, the venting system must be corrected in accordance with the National Fuel Gas Code, ANSI Z223.1-2002/NFPA 54-2002 and/or CSA B149.1, Natural Gas and Propane Installation Code.
9. After it has been determined that each appliance connected to the venting system properly vents when tested as outlined above, return doors, windows, exhaust fans, fireplace dampers and any other gas-fired appliance to their previous conditions of use.

Vent system or vent connectors may need to be resized. For any other appliances when resizing vent systems or vent connectors, system or connector must be sized to approach minimum size as determined using appropriate table found in the NFGC or NSC-NGPIC.

## COMBUSTION-AIR AND VENT PIPING

### General

## ⚠ WARNING

### FIRE AND EXPLOSION HAZARD

Failure to follow this warning could result in fire, property damage, personal injury, or death.

Solvent cements are combustible. Keep away from heat, sparks, and open flame. Use only in well-ventilated areas. Avoid breathing in vapor or allowing contact with skin or eyes.

Combustion-air and vent pipe, fittings, primers, and solvents must conform to American National Standards Institute (ANSI) standards and American Society for Testing and Materials (ASTM)

standards. See Table 7 for approved materials for use in the U.S.A. See Table 8 for maximum pipe lengths and Fig. 39, 40, and 41 for exterior piping arrangements.

In Canada, construct all combustion-air and vent pipes for this unit of CSA or ULC listed schedule-40 PVC, PVC-DWV or ABS-DWV pipe and pipe cement. SDR pipe is NOT approved in Canada.

Vent pipe termination must be installed with adequate clearances to building openings and equipment to comply with national and local codes.

### Combustion Air Pipe

## ⚠ CAUTION

### UNIT CORROSION HAZARD

Excessive exposure to contaminated combustion air may result in safety and performance related problems.

Combustion air must not be taken from inside a structure that is frequently contaminated by halogens, which include fluorides, chlorides, bromides, and iodides. These elements are found in aerosols, detergents, bleaches, cleaning solvents, salts, air fresheners, adhesives, paint, and other household products. Locate combustion-air inlet as far as possible from swimming pool and swimming pool pump house.

**NOTE:** Furnace combustion-air connections are sized for 2-in. pipe. The combustion-air pipe will be 2-in. diameter in all installations.

See Table 10 for required clearances.

Furnace combustion-air connection must be attached as shown in Fig. 34. Combustion-air intake housing plug may need to be relocated in some applications.

Combustion-air pipe must terminate outside of furnace casing with 1 elbow. Orient elbow so that opening faces down for upflow or downflow applications. Orient elbow so that it faces sideways (left or right) for horizontal left or horizontal right applications. (See Fig. 34.) Maintain a 3-in. minimum clearance between the opening of the combustion-air inlet pipe and any object.

**NOTE:** All pipe joints must be cemented except attachment of combustion-air inlet pipe to inlet housing connection, since it may be necessary to remove pipe for servicing.

Install combustion air inlet pipe as follows:

1. Assemble combustion-air inlet pipe.
  - a. Permanently install perforated disk assembly (factory-supplied in loose parts bag) in combustion-air elbow using RTV or by cementing. (See Fig. 35.)

**For 120,000 Btuh size units only:** Separate the 2 halves of perforated disk assembly and use only the shouldered disk half.
  - b. Determine length of straight portion of combustion-air inlet pipe from table in Fig. 35.
  - c. Cut field-supplied 2-in diameter PVC pipe to determined length.
  - d. Permanently attach elbow/perforated disk assembly to straight portion of pipe using RTV or by cementing. (See Fig. 35.)
2. Attach combustion-air inlet pipe.
  - a. Determine location of combustion-air intake pipe connection to combustion-air intake housing as shown in Fig. 34 for application.
  - b. Reposition combustion-air intake housing plug fitting in appropriate unused intake housing connection.

**Table 9—Maximum Allowable Exposed Vent Pipe Length (ft) With and Without Insulation in Winter Design Temperature Ambient\***

FURNACE SIZE	WINTER DESIGN TEMPERATURE (°F)	MAX PIPE DIAMETER (IN.)	WITHOUT INSULATION	WITH 3/8-IN. OR THICKER INSULATION†
040	20	1.5	51	70
	0	1.5	28	70
	-20	1.5	16	70
	20	2	45	70
	0	2	22	70
060	-20	2	10	58
	20	2	65	70
	0	2	35	70
080	-20	2	20	70
	20	2	55	55
	0	2	48	55
	-20	2	30	55
	20	2.5	70	70
	0	2.5	47	70
100	-20	2.5	28	70
	20	2.5	40	40
	0	2.5	40	40
	-20	2.5	38	40
	20	3	70	70
	0	3	50	70
120	-20	3	28	70
	20	3	70	70
	0	3	61	70
	-20	3	37	70
	20	4	70	70
	0	4	48	70
	-20	4	23	70

\* Pipe length (ft) specified for maximum pipe lengths located in unconditioned spaces. Pipes located in unconditioned space cannot exceed total allowable pipe length as specified in Table 9.  
 † Insulation thickness based on R value of 3.5 per in.

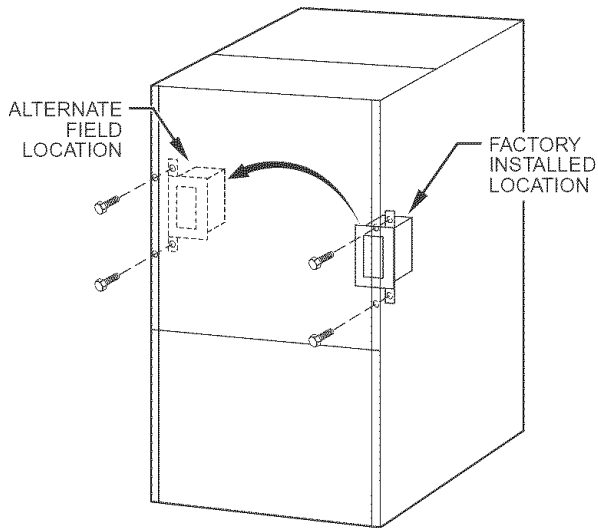

**Fig. 31—Relocating J-Box**

A00212

- c. Install pipe support (factory-supplied in loose parts bag) into selected furnace casing combustion-air pipe hole. Pipe support should be positioned at bottom of casing hole.
- d. Insert assembled combustion-air inlet pipe into intake housing.

- e. Make sure elbow is oriented in an acceptable direction and that the minimum clearance of 3 in. is observed. (See Fig. 34.)
- f. Drill a 1/8-in. hole in 2-in. combustion-air inlet pipe using hole in intake housing as a guide.
- g. Install a field-supplied No. 6 or No. 8 sheet metal screw into combustion-air pipe.
- h. Install casing hole filler cap (factory-supplied) in loose parts bag) in unused combustion-air pipe casing hole.

**NOTE:** Do not attach combustion-air intake pipe permanently to combustion-air intake housing since it may be necessary to remove pipe for service of igniter or flame sensor.

**COMBUSTION-AIR INTAKE HOUSING PLUG FITTING**

The combustion-air intake plug fitting must be installed in unused combustion-air intake housing. This fitting must be attached by using RTV sealant, or by drilling a 1/8-in. hole in fitting, using hole in intake housing as a guide. Install a field-supplied No. 6 or No. 8 sheet metal screw.

**NOTE:** DO NOT OVERTIGHTEN SCREW. Breakage of intake housing or fitting may cause air leakage to occur.

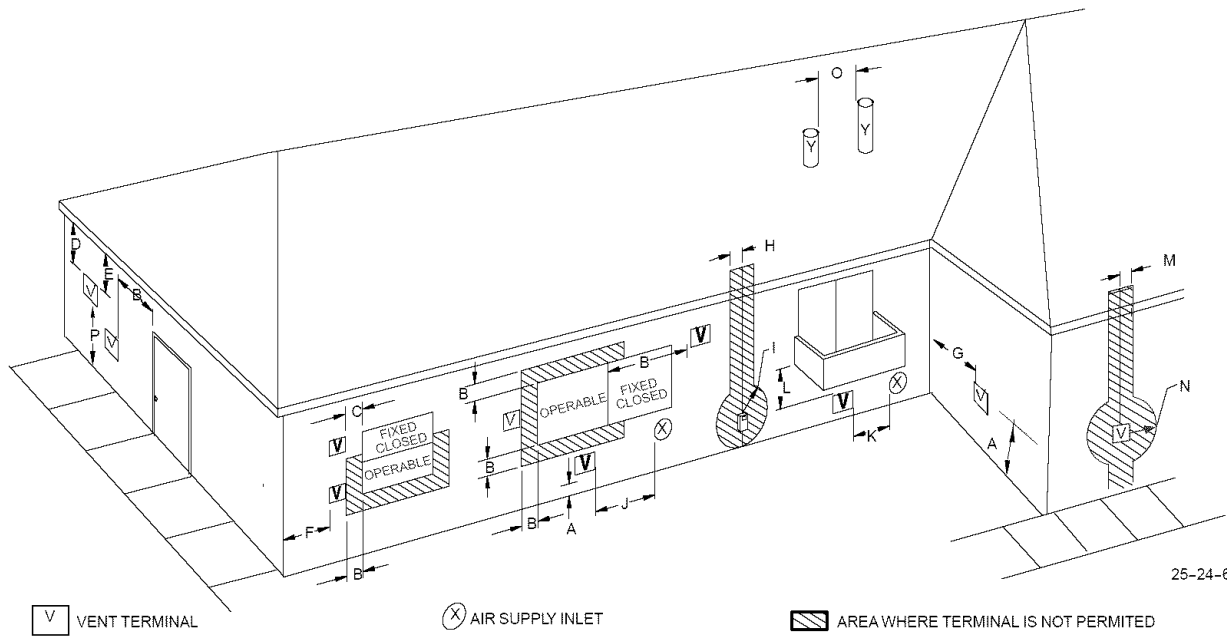

25-24-65-2

Item	Clearance Descriptions	Canadian Installation (1)	U.S. Installation (2)
A	Clearance above grade, veranda, porch, deck, balcony, or anticipated snow level	12 (30cm) #	12" (30 cm)
B	Clearance to a window or door that may be opened	6" (15 cm) for appliances 10,000 BTUH (3kW), 12 (30 cm) for appliances > 10,000 Btuh(3 kW) and 100,000 Btuh (30 kW), 36 (91 cm) for appliances > 100,000 Btuh (30 kW)	4' (1.2 m) below or to the side of the opening, 1 (30 cm) above the opening.
C	Clearance to a permanently closed window	*	*
D	Vertical clearance to a ventilated soffit located above the terminal within a horizontal distance of 2 (61cm) from the centerline of the terminal	*	*
E	Clearance to an unventilated soffit	*	*
F	Clearance to an outside corner	*	*
G	Clearance to an inside corner	*	*
H	Clearance to each side of the centerline extended above electrical meter or gas service regulator assembly	3' (91 cm) within 15' (4.5 m) above the meter/regulator assembly	3' (91 cm) within 15 (4.5 m) above the meter/regulator assembly
I	Clearance to service regulator vent outlet	3' (91 cm)	*
J	Clearance to non-mechanical air supply inlet to building or the combustion air inlet to any other appliance	6" (15 cm) for appliances 10,000 BTUH (3kW), 12 (30 cm) for appliances > 10,000 Btuh(3 kW) and 100,000 Btuh (30 kW), 36 (91 cm) for appliances > 100,000 Btuh (30 kW)	4' (1.2 m) below or to the side of opening: 1 (30 cm) above opening.
K	Clearance to a mechanical air supply inlet	6' (1.83 m)	3' (91 cm) above if within 10'(3m horizontally)
L	Clearance under a veranda, porch, deck, or balcony	12" (30 cm) +	*
M	Clearance to each side of the centerline extended above or below vent terminal of the furnace to a dryer or water heater vent, or other appliance's direct vent intake or exhaust.	*	*
N	Clearance to the vent terminal of a dryer vent, water heater vent, or other appliances direct vent intake or exhaust.	*	*
O	Clearance from a plumbing vent stack	*	*
P	Clearance above paved sidewalk or paved driveway located on public property	7' (2.13m)**	7' (2.13m)

(1.) In accordance with the current CSA B149.1, Natural Gas and Propane Installation Code  
 (2.) In accordance with the current ANSI Z223.1/NFPA 54, National Fuel Gas Code  
 # 18" (46 cm) above roof surface  
 + Permitted only if veranda, porch, deck, or balcony is fully open on a minimum of two sides beneath the floor.  
 \* For clearances not specified in ANSI Z223.1/NFPA 54 or CSA B149.1, clearances shall be in accordance with local installation codes and the requirements of the gas supplier and the Manufacturer's installation instructions.  
 \*\* A vent shall not terminate above a sidewalk or paved driveway that is located between two single family dwellings and serves both dwellings.

- Notes:
- The vent for this appliance shall not terminate
    - Over public walkways; or
    - Near soffit vents or crawl space vents or other areas where condensate or vapor could create a nuisance or hazard or property damage; or
    - Where condensate vapor could cause damage or could be detrimental to the operation of regulators, relief valves, or other equipment.
  - When locating vent terminations, consideration must be given to prevailing winds, location, and other conditions which may cause recirculation of the combustion products of adjacent vents. Recirculation can cause poor combustion, inlet condensate problems, and accelerated corrosion of the heat exchangers.
  - Avoid venting under a deck or large overhang. Recirculation could occur and cause performance or system problems.

→ Table 10—Other than Direct Vent Termination Clearance

A05013

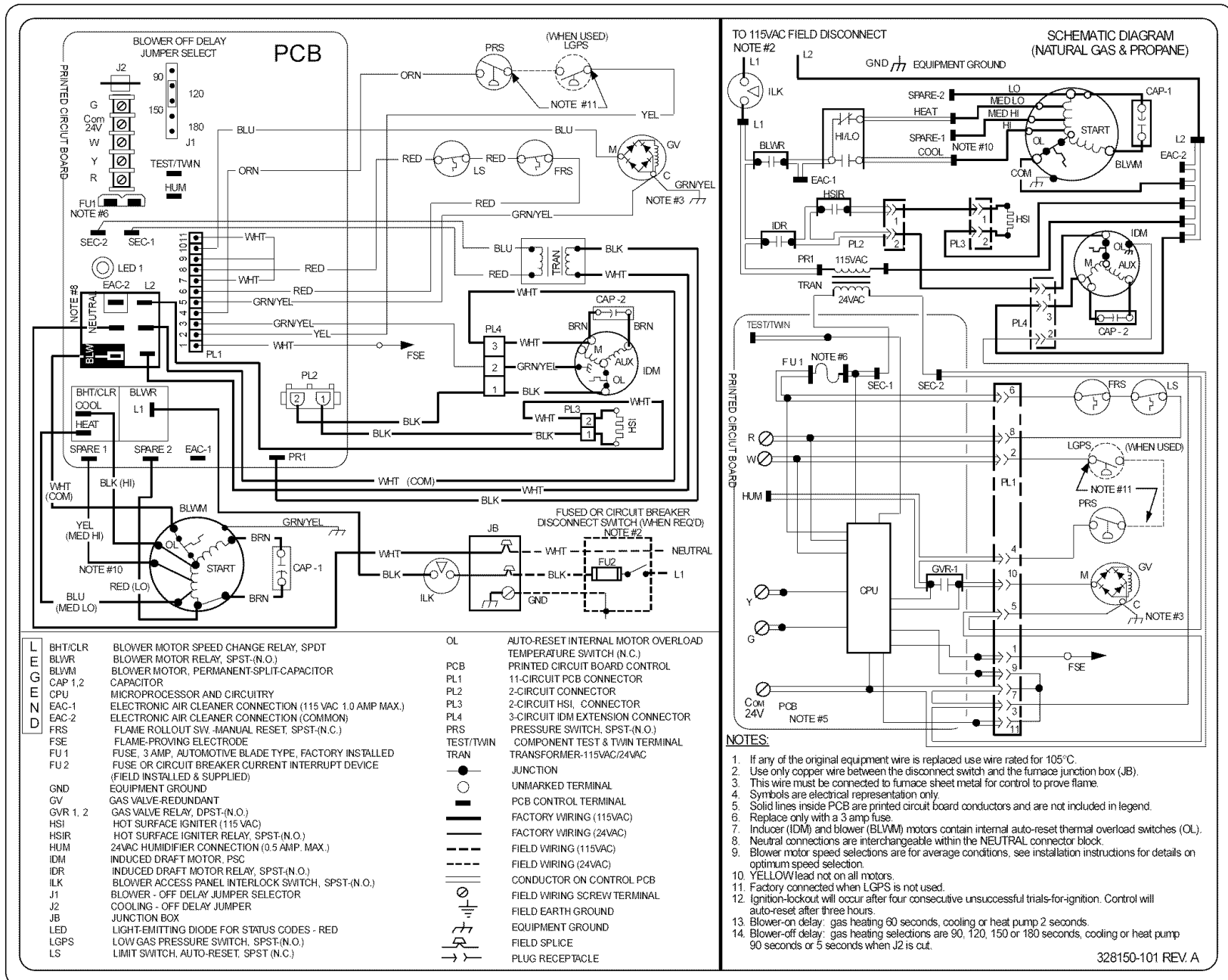

Fig. 32—Wiring Diagram

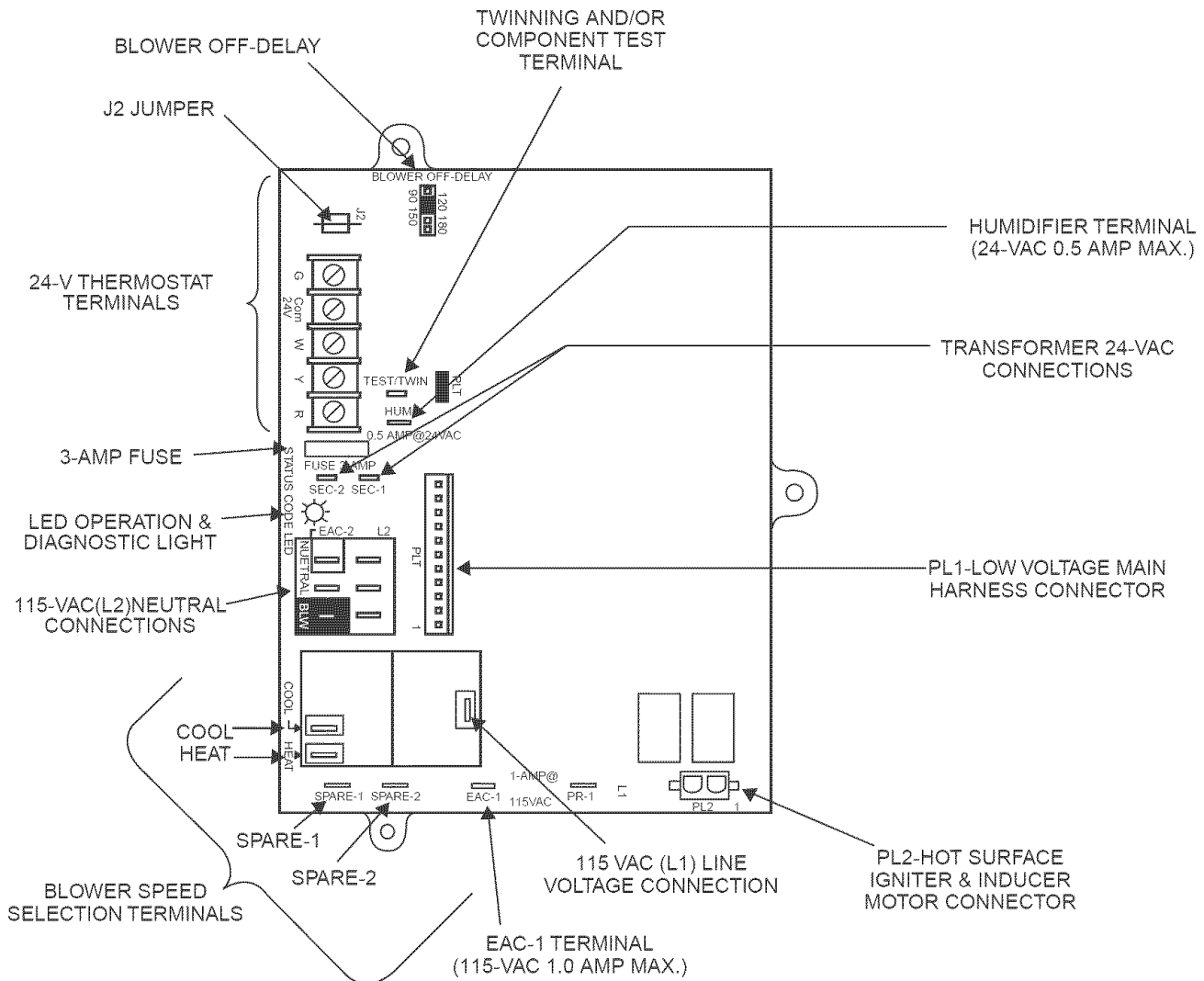

Fig. 33—Furnace Control

A02100

A plugged drain connection has been provided on this fitting for use when moisture is found in combustion-air intake pipe and combustion box. If use of this drain connection is desired, drill out fitting's tap plug with a 3/16-in. drill and connect a field-supplied 3/8-in. tube. This tube should be routed to open condensate drain for furnace and A/C (if used), and should be trapped. (See Fig. 36.)

#### Vent Pipe

**NOTE:** Furnace vent pipe connections are sized for 2-in. pipe. Any vent pipe size change should be made outside furnace casing in vertical pipe. (See Fig. 37.) This allows proper drainage of vent condensate.

Determine vent pipe diameter and maximum pipe lengths using Table 8.

Furnace vent pipe connection must be attached as shown in Fig. 34. Inducer housing alternate vent cap may need to be relocated in some applications.

**NOTE:** Starting at furnace, slope vent pipe a minimum of 1/4 in. per linear ft upward to termination(s) with no sags between hangers.

### CAUTION

#### UNIT MAY NOT OPERATE

Failure to follow this caution may result in intermittent unit operation.

When vent pipe is exposed to temperatures below freezing, such as when it passes through an unheated space or when a chimney is used as a raceway, pipe must be insulated as described in Table 9 with Armaflex-type insulation.

An abandoned masonry chimney may be used as a raceway for properly insulated and supported vent pipe. Each furnace must have its own vent pipe and be terminated individually, as shown in Fig. 41.

Other gas appliances with their own venting system may also use the abandoned chimney as a raceway providing it is permitted by local code, the current edition of the National Fuel Gas Code and the vent or liner manufacturer's installation instructions. Care must be taken to prevent the exhaust gases from one appliance from contaminating the combustion air of other gas appliances.



**NOTE:** Select 1 vent pipe connection and 1 combustion-air pipe connection.

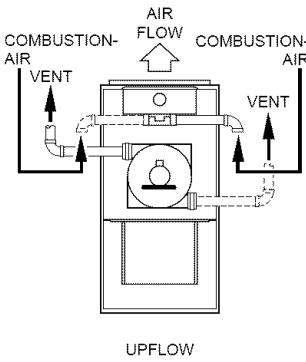

**NOTE:** Select 1 vent pipe connection and 1 combustion-air pipe connection.

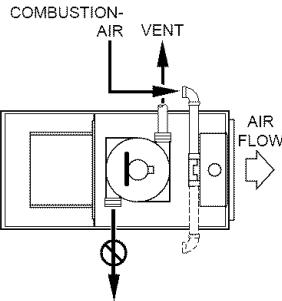
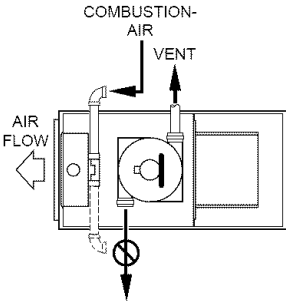
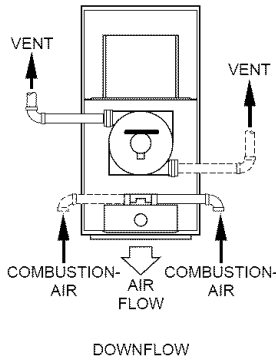

A96188

**CAUTION**

**UNIT MAY NOT OPERATE**

Failure to follow this caution may result in intermittent unit operation. Make sure there is adequate clearance (3-in. minimum) to any fixed or loose objects in order to ensure an adequate combustion-air supply.

**Fig. 34—Combustion-Air and Vent Pipe Connections**

**WARNING**

**CARBON MONOXIDE POISONING AND PROPERTY DAMAGE HAZARD**

Failure to follow this warning could result in property damage, personal injury, or death. Vent pipes must be airtight and watertight.

**NOTE:** The minimum vent pipe length for these furnaces is 5 ft. Short pipe lengths (5-8 ft) may discharge water droplets. These droplets may be undesirable, and a 12-in. minimum offset pipe section is recommended to reduce excessive droplets from exiting vent pipe outlet. (See Fig. 38.)

**NOTE:** Do not count elbows or pipe sections in terminations or within furnace. See shaded areas in Fig. 40.

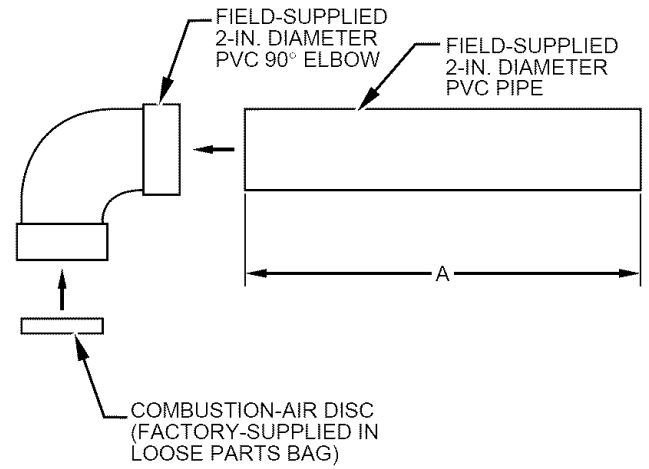

A96211

**Length of Straight Pipe Portion of Combustion-Air Inlet Pipe Assembly (In.)**

CASING WIDTH	A
17-1/2	8-1/2 ± 1/2
21	10-1/2 ± 1/2
24-1/2	12 ± 1/2

**Fig. 35—Combustion-Air Inlet Pipe Assembly**

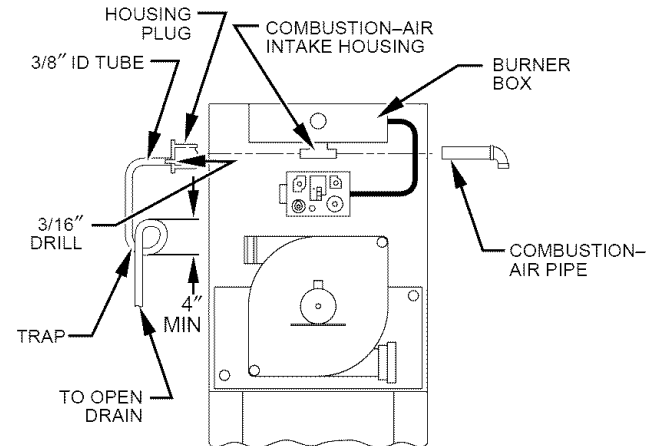

A96190

**Fig. 36—Air Intake Housing Plug Fitting Drain**

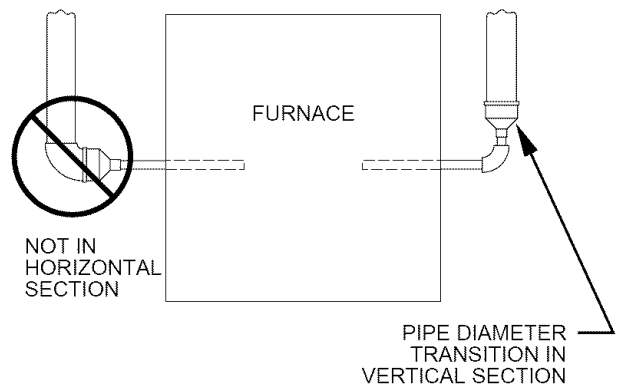

A93034

**Fig. 37—Vent Pipe Diameter Transition Location and Elbow Configuration**

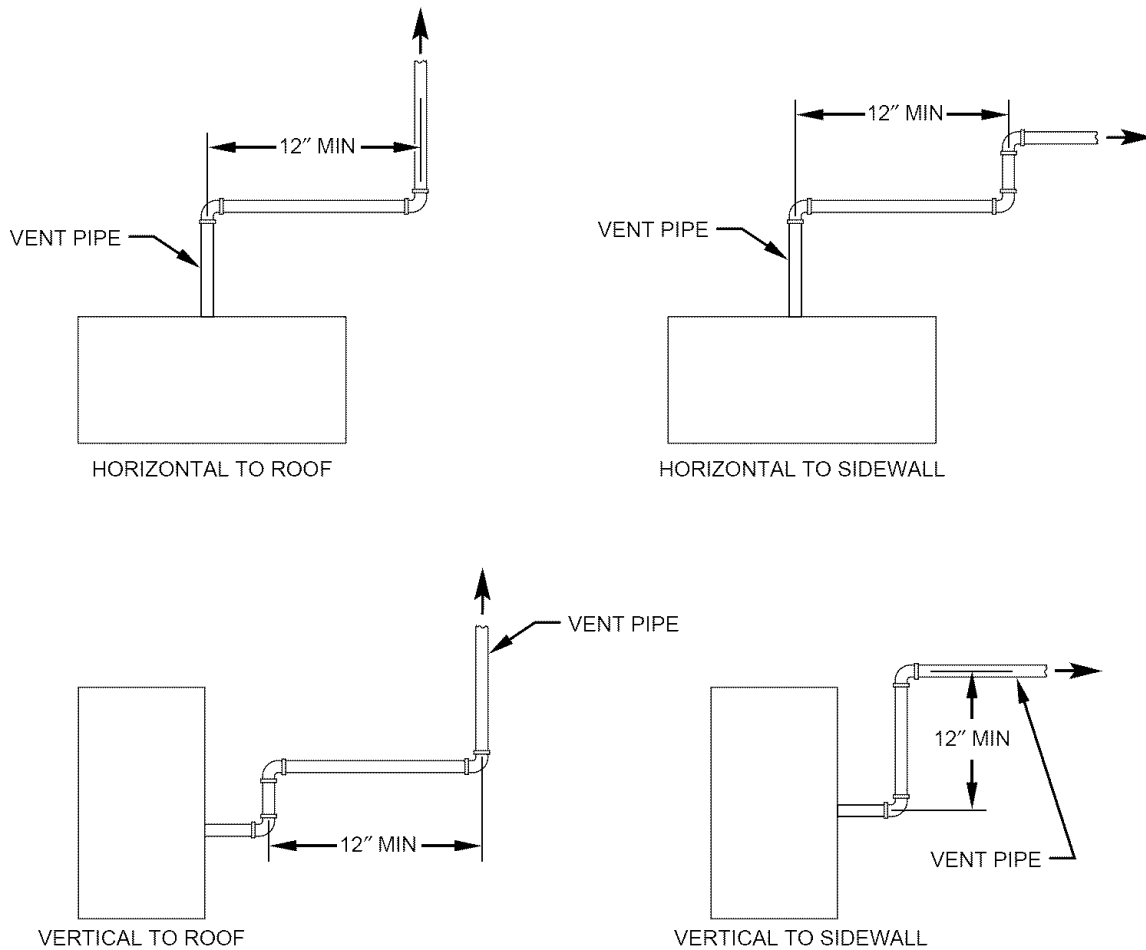

**NOTE:** A 12-in. minimum offset pipe section is recommended with short (5 to 8 ft) vent systems. This recommendation is to reduce excessive condensate droplets from exiting the vent pipe.

A96189

**Fig. 38—Short Vent (5 to 8 Ft) System**

**EXAMPLE:**

An 080-12 size furnace located in Indianapolis, elevation 650 ft above sea level, could be installed in an application requiring 3 elbows and 32 ft of vent pipe. Table 8 indicates this application would allow a 2-in. diameter vent pipe. At 0-2000 ft elevation, 2-in. pipe is good for up to 35 ft with 3 elbows. If same installation were in Albuquerque, elevation 5250 ft above sea level, installation would require 2-1/2 in. vent pipe. At 5001- to 6000-ft elevation, 2-in. pipe is allowed for up to 23 ft with 3 elbows, but 2-1/2 in. pipe can be used for up to 70 ft with 3 elbows.

Install vent pipe as follows:

1. Determine location of vent pipe connection to inducer housing as shown in Fig. 34 for application.
2. Reposition elastomeric (rubber) inducer housing outlet cap and clamp to appropriate unused inducer housing connection. Tighten clamp.

**⚠ CAUTION**

**UNIT DAMAGE HAZARD**

Failure to follow this caution may result in unit component damage. Inducer housing outlet cap must be installed and fully seated against inducer housing. Clamp must be tightened to prevent any condensate leakage.

3. Install pipe support (factory-supplied in loose parts bag) into selected furnace casing vent pipe hole. Pipe support should be positioned at bottom of casing hole.

**⚠ WARNING**

**CARBON MONOXIDE POISONING AND UNIT DAMAGE HAZARD**

Failure to follow this warning could result in personal injury or death and unit damage. Vent pipe must be installed and fully seated against inducer housing internal stop. Clamp must be tightened to prevent any condensate leakage.

**NOTE:** A 2-in. diameter pipe must be used within the furnace casing. Make all pipe diameter transitions outside furnace casing.

4. Be certain that mating surfaces of inducer housing connection elastomeric coupling, and 2-in. diameter vent pipe are clean

and dry. Assemble the elastomeric (rubber) vent coupling (with 2 loose clamps) onto inducer housing connection. Insert the 2-in. diameter vent pipe through the elastomeric (rubber) coupling and fully into inducer housing connection until it bottoms on the internal stop. Tighten both clamps to secure the pipe to inducer housing. Tighten the clamp screws to 15 in.-lb. of torque.

5. Install casing hole filler cap (factory-supplied in loose parts bag) in unused vent pipe casing hole.

#### VENT EXTENSION PIPE

Some furnaces are supplied with a PVC vent extension pipe (2-in. diameter by 12-in. long). This pipe has a built-in channel to assist vent condensate disposal. When this vent extension pipe is supplied, it must be used to connect the field vent pipe to furnace inducer housing on ALL upflow and downflow applications.

**NOTE:** See label on vent extension pipe for proper installation. This pipe may be shortened if an elbow is used to connect vent extension tube to field-installed vent pipe.

6. Working from furnace to outside, cut pipe to required length(s).
7. Deburr inside and outside of pipe.
8. Chamfer outside edge of pipe for better distribution of primer and cement.
9. Clean and dry all surfaces to be joined.
10. Check dry fit of pipe and mark insertion depth on pipe.

**NOTE:** It is recommended that all pipes be cut, prepared, and preassembled before permanently cementing any joint.

11. After pipes have been cut and preassembled, apply generous layer of cement primer to pipe fitting socket and end of pipe to insertion mark. Quickly apply approved cement to end of pipe and fitting socket (over primer). Apply cement in a light, uniform coat on inside of socket to prevent buildup of excess cement. Apply second coat.
12. While cement is still wet, twist pipe into socket with 1/4 turn. Be sure pipe is fully inserted into fitting socket.
13. Wipe excess cement from joint. A continuous bead of cement will be visible around perimeter of a properly made joint.
14. Handle pipe joints carefully until cement sets.
15. Support vent piping a minimum of every 5 ft (3 ft for SDR-21 or -26 PVC) using perforated metal hanging strap.
16. Slope vent pipe downward toward furnace a minimum of 1/4 in. per linear ft with no sags between hangers.
17. Use appropriate methods to seal openings where vent pipe passes through roof or sidewall.

#### Extended Exposed Sidewall Pipes

Sidewall vent pipe termination may be extended beyond area shown in Fig. 40 in outside ambient by insulating pipe as indicated in Table 9.

1. Determine vent pipe diameter, as stated above, using total pipe length and number of elbows.
2. Find appropriate temperature for your application and furnace model using winter design temperature (used in load calculations).
3. Determine required insulation thickness for exposed pipe lengths.

**NOTE:** Pipe length (ft) specified for maximum pipe lengths located in unconditioned spaces cannot exceed total allowable pipe length as specified in Table 8.

#### VENT TERMINATION

Vent pipe must terminate either through roof or sidewall. See Table 10 for required clearances. See Fig. 39, 40, and 41 for exterior piping arrangements.

Consideration of the following should be made when determining an appropriate location for termination:

1. Comply with all clearance requirements stated in Table 10.
2. Termination should be positioned where vent vapors will not damage plants/shrubs or air conditioning equipment.
3. Termination should be positioned where it will not be damaged by or subjected to foreign objects such as stones, balls, etc.
4. Termination should be positioned where vent vapors are not objectionable.

#### MULTIVENTING

When 2 or more 58MSA Furnaces are vented near each other, each furnace must be individually vented. NEVER common vent or breach vent 58MSA furnaces.

#### Step 10—Condensate Drain

##### GENERAL

Condensate trap is shipped installed in the blower shelf and factory connected for UPFLOW applications. Condensate trap must be RELOCATED for use in DOWNFLOW and HORIZONTAL applications.

Condensate trap MUST be used for all applications.

An external trap is not required when connecting the field drain to this condensate trap.

The field drain connection (condensate trap or drain tube coupling) is sized for 1/2-in. CPVC, 1/2-in. PVC, or 5/8-in. ID tube connection.

Drain pipe and fittings must conform to ANSI standards and ASTM D1785, D2466 or D2846. CPVC or PVC cement must conform to ASTM D2564 or F493. Primer must conform to ASTM F656. In Canada, use CSA or ULC listed schedule 40 CPVC or PVC drain pipe, fittings, and cement.

When a condensate pump is required, select a pump which is approved for condensing furnace applications. To avoid condensate spillage, select a pump with an overflow switch.

#### **⚠ CAUTION**

##### **UNIT MAY NOT OPERATE**

Failure to follow this caution may result in intermittent unit operation.

Unit must not be installed, operated, and then turned off and left in an unconditioned structure during cold weather when temperature drops to 32°F and below unless drain trap and drain line have adequate freeze protection. See Service and Maintenance Instructions for winterizing procedures. (See Fig. 15.)

Furnace condensate is mildly acidic, typically in the pH range of 3.2 to 4.5. Due to corrosive nature of unneutralized condensate, a condensate pH neutralizing filter may be desired. Check with local authorities to determine if a pH neutralizer is required.

##### APPLICATION

The furnace, A/C, and humidifier drains may be combined and drained together. The A/C drain must have an external, field-supplied trap prior to the furnace drain connection. All drain connections (furnace, A/C, or humidifier) must be terminated into

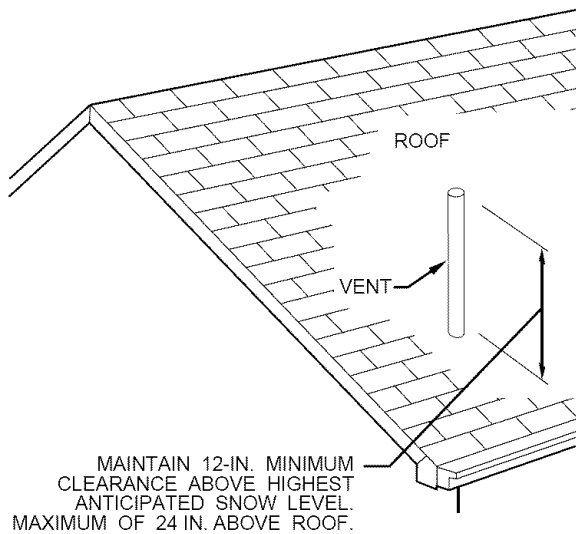

MAINTAIN 12-IN. MINIMUM CLEARANCE ABOVE HIGHEST ANTICIPATED SNOW LEVEL. MAXIMUM OF 24 IN. ABOVE ROOF.

A96191

**Fig. 39—Roof Termination (Preferred)**

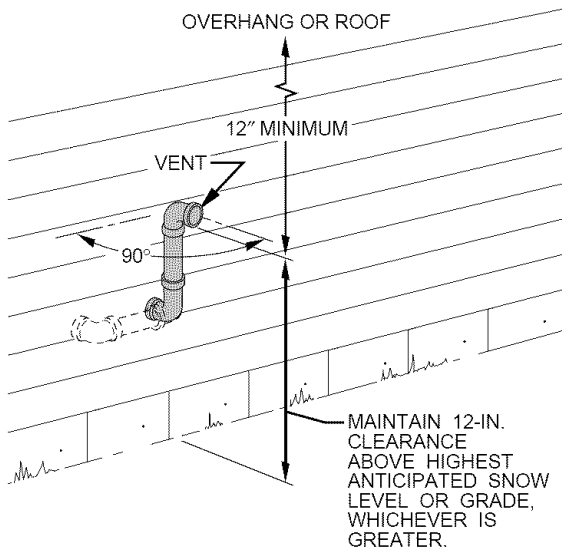

MAINTAIN 12-IN. CLEARANCE ABOVE HIGHEST ANTICIPATED SNOW LEVEL OR GRADE, WHICHEVER IS GREATER.

A96192

**Fig. 40—Sidewall Termination with 2 Elbows (Preferred)**

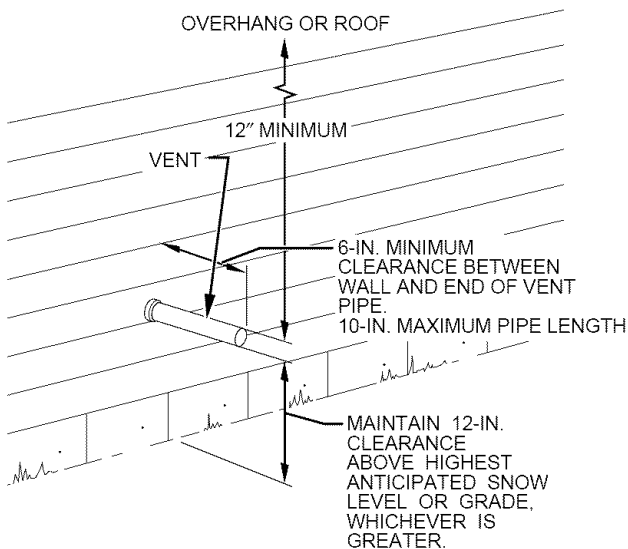

MAINTAIN 12-IN. CLEARANCE ABOVE HIGHEST ANTICIPATED SNOW LEVEL OR GRADE, WHICHEVER IS GREATER.

A96210

**Fig. 41—Sidewall Termination with Straight Pipe**

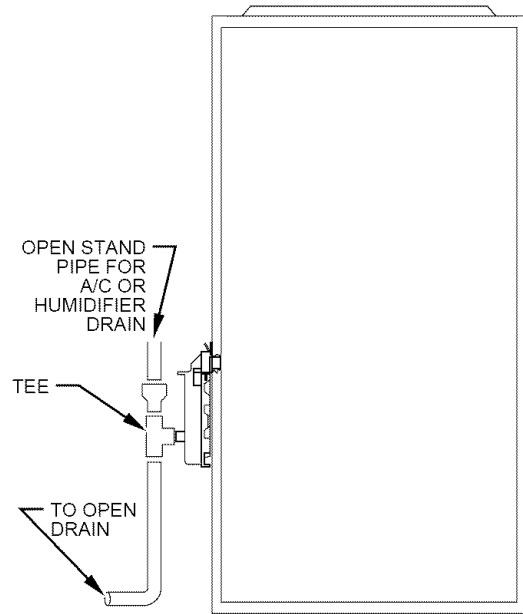

A94054

**Fig. 42—Example of Field Drain Attachment**

an open or vented drain as close to the respective equipment as possible to prevent siphoning of the equipment's drain.

See Fig. 42 for example of possible field drain attachment using 1/2-in. CPVC or PVC tee for vent and A/C or humidifier drain connection.

Outdoor draining of the furnace is permissible if allowed by local codes. Caution should be taken. Freezing ambient may freeze drain pipe and prohibit draining.

**⚠ WARNING**

**PERSONAL INJURY HAZARD**  
 Caution should be taken to prevent draining where slippery conditions could cause personal injuries.  
 Excessive condensate draining may cause saturated soil conditions which could result in damage to plants.

**CONDENSATE DRAIN PROTECTION**

Freezing condensate left in condensate trap and drain line may cause cracks, and possible water damage may occur. If freeze protection is required, use condensate freeze protection accessory or equivalent 3 to 6 watt per ft at 120v and 40°F self-regulating, shielded, and waterproof heat tape. See Installation Instructions supplied with accessory or heat tape manufacturer's recommendations.

1. Fold heat tape in half and wrap on itself 3 times.
2. Locate heat tape between sides of condensate trap back. (See Fig. 43.)
3. Use wire ties to secure heat tape in place. Wire ties can be positioned in notches of condensate trap sides. (See Fig. 43.)
4. Wrap field drain pipe with remaining heat tape, approximately 1 wrap per ft.
5. When using field-supplied heat tape, follow heat tape manufacturer's instructions for all other installation guidelines.

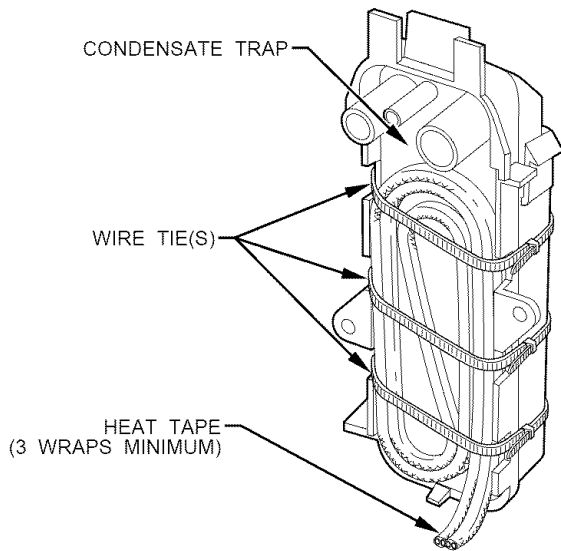

**Fig. 43—Condensate Trap Heat Tape**

A93036

**START-UP, ADJUSTMENTS AND SAFETY CHECK**

**Step 1—General**

1. Furnace must have a 115-v power supply properly connected and grounded. Proper polarity must be maintained for correct operation.

**NOTE:** Proper polarity must be maintained for 115-v wiring. If polarity is incorrect, furnace control fault indicator light will flash rapidly and furnace will not operate.

2. Thermostat wire connections at terminals R, W, G, and Y must be made at 24-v terminal block on furnace control center.
3. Natural gas service pressure must not exceed 0.5 psig (14-in. wc), but must be no less than 0.16 psig (4.5-in. wc).
4. Blower access panel must be in place to complete 115-v electrical circuit to furnace.

**⚠ CAUTION**

**FIRE HAZARD**

Failure to follow this caution may result in intermittent unit operation.

These furnaces are equipped with a manual reset limit switch in burner box. This switch will open and shut off power to gas control valve if an overheat condition (flame rollout) occurs in burner enclosure. Correct inadequate combustion-air supply or improper venting condition and reset switch. **DO NOT** jumper this switch.

Before operating furnace, check flame rollout manual reset switch for continuity. If necessary, press button to reset switch.

**Step 2—Prime Condensate Trap with Water**

**⚠ CAUTION**

**UNIT MAY NOT OPERATE**

Failure to follow this caution may result in intermittent unit operation.

Condensate trap must be PRIMED or proper draining may not occur. The condensate trap has 2 internal chambers which can ONLY be primed by pouring water into the inducer drain side of condensate trap.

1. Remove upper inducer housing drain connection cap. (See Fig. 44.)
2. Connect field-supplied 1/2-in. ID tube to upper inducer housing drain connection.

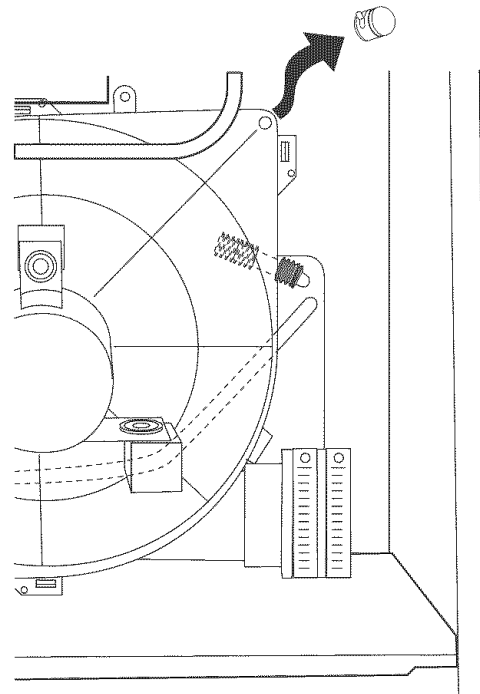

**Fig. 44—Inducer Housing Drain Tube Cap**

A99118

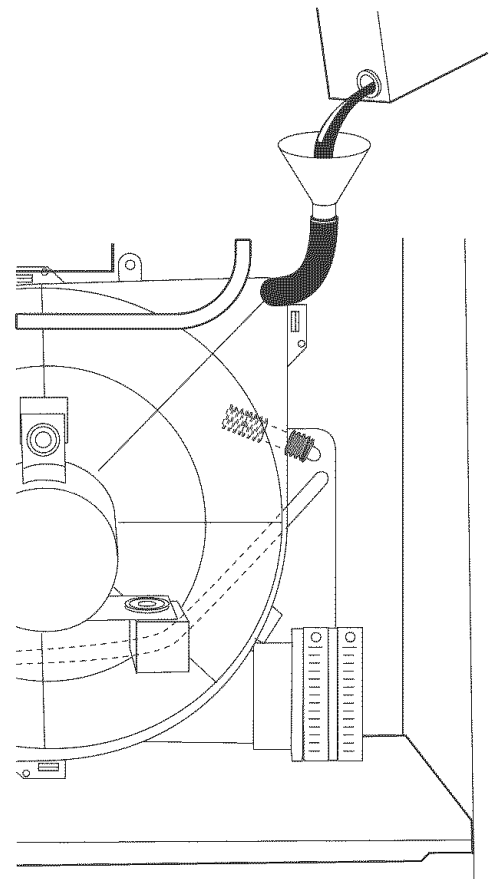

**Fig. 45—Filling Condensate Trap**

A99119

3. Insert field-supplied funnel into tube.
4. Pour 1 quart of water into funnel/tube. Water should run through inducer housing, overflow condensate trap, and flow into open field drain. (See Fig. 45.)
5. Remove funnel and tube from inducer housing and replace drain connection cap and clamp.

### Step 3—Purge Gas Lines

#### **⚠ WARNING**

##### **FIRE AND EXPLOSION HAZARD**

Failure to follow this warning could result in a fire, explosion, personal injury, or death.  
Never purge a gas line into a combustion chamber. Never test for gas leaks with an open flame. Use a commercially available soap solution made specifically for the detection of leaks to check all connections.

If not previously done, purge lines after all connections have been made and check for leaks.

### Step 4—Sequence of Operation

#### **⚠ CAUTION**

##### **FURNACE MAY NOT OPERATE**

Failure to follow this caution may result in furnace operation stopping and water pipes freezing during cold weather.  
Furnace control must be grounded for proper operation, or control will lock out. Control is grounded through green/yellow wire routed to gas valve and burner box screw.

Using the schematic diagram in Fig. 32, follow the sequence of operation through the different modes. Read and follow the wiring diagram very carefully.

**NOTE:** If a power interruption occurs during a call for heat (W), the control will start a 90-second blower-only ON period two seconds after power is restored, if the thermostat is still calling for gas heating. The red LED light will flash code 12 during the 90-second period, after which the LED will be ON continuous, as long as no faults are detected. After the 90-second period, the furnace will respond to the thermostat normally.

The blower door must be installed for power to be conducted through the blower door interlock switch ILK to the furnace control CPU, transformer TRAN, inducer motor IDM, blower motor BLWM, hot-surface igniter HSI, and gas valve GV.

#### 1. Heating

(See Fig. 30 for thermostat connections.)

The wall thermostat "calls for heat", closing the R to W circuit. The furnace control performs a self-check, verifies the pressure switch contacts PRS are open, and starts the inducer motor IDM.

- a. **Inducer Prepurge Period-** As the inducer motor IDM comes up to speed, the pressure switch contacts PRS close, 24 vac power is supplied for a field installed humidifier at the HUM terminal and the control begins a 15-second prepurge period.
- b. **Igniter Warm-Up-** At the end of the prepurge period, the Hot-Surface Igniter HSI is energized for a 17-second igniter warm-up period.
- c. **Trial-for-Ignition Sequence-** When the igniter warm-up period is completed, the main gas valve relay contacts GVR close to energize the gas valve GV, the gas valve opens. The gas valve GV permits gas flow to the burners where it is ignited by the Hot Surface Igniter HSI. Five seconds after the GVR closes, a 2-second flame period begins. The HSI igniter will remain energized until the flame is sensed or until the 2-second flame proving period begins.
- d. **Flame-Proving-** When the burner flame is proved at the flame-proving sensor electrode FSE, the furnace control CPU begins the blower-ON delay period and continues to hold the gas valve GV open. If the burner flame is not

proved within two seconds, the control CPU will close the gas valve GV, and the control CPU will repeat the ignition sequence for up to three more Trials-For-Ignition before going to Ignition-Lockout. **Lockout will be reset** automatically after three hours, by momentarily interrupting 115 vac power to the furnace, or by interrupting 24 vac power at SEC1 or SEC2 to the furnace control CPU (not at W, G, R, etc.)

If flame is proved when flame should not be present, the furnace control CPU will lock out of Gas-Heating mode and operate the inducer motor IDM until flame is no longer proved.

- e. **Blower-On Delay-** If the burner flame is proven, the blower motor is energized on HEAT speed 66 seconds after the gas valve GV is energized. Simultaneously, the electronic air cleaner terminal EAC-1 is energized and remains energized as long as the blower motor BLWM is energized.
- f. **Blower-Off Delay-** When the thermostat is satisfied, the R-to-W circuit is opened, de-energizing the gas valve GV, stopping gas flow to the burners, and de-energizing the humidifier terminal HUM. The inducer motor IDM will remain energized for a 15-second post-purge period. The blower motor BLWM and air cleaner terminal EAC-1 will remain energized for 90, 120, 150, or 180 seconds (depending on the blower-OFF delay selection). The furnace control CPU is factory-set for a 120-second blower-OFF delay.

#### 2. Cooling Mode

(See Fig. 30 for thermostat connections)

The thermostat closes the R-to-G-and-Y circuits. The R-to-Y circuit starts the outdoor unit, and the R-to-G and Y circuits start the furnace blower motor BLWM on COOL speed. The electronic air cleaner terminal EAC-1 is energized with 115 vac when the blower motor BLWM is operating. When the thermostat is satisfied, the R-to-G-and-Y circuits are opened. The outdoor unit will stop, and the furnace blower motor BLWM will continue operating on the COOL speed for an additional 90 seconds. Cut jumper J2 to reduce the cooling off-delay to 5 seconds. (See Fig. 33.)

#### 3. Continuous Blower Mode

When the R-to-G circuit is closed by the thermostat, the blower motor BLWM will operate on continuous-blower speed (same as HEAT speed). Terminal EAC-1 is energized as long as the blower motor BLWM is energized. During "a call for heat," the blower BLWM will stop during igniter warm-up (17 seconds), ignition (7 seconds), and blower-ON delay (66 seconds), allowing the furnace heat exchangers to heat up more quickly, then restarts at the end of the blower-ON delay period at HEAT speed.

In heating, the furnace control CPU will continue running the blower motor BLWM at HEAT speed after the selected blower-OFF delay period is completed.

When the thermostat "calls for cooling", the blower motor BLWM will operate at COOL speed. When the thermostat is satisfied, the blower motor BLWM will operate an additional 90 seconds on COOL speed before reverting back to HEAT speed. Jumper J2 can be cut to reduce the cooling off-delay to 5 seconds. (See Fig. 33.)

When the R-to-G circuit is opened, the blower motor BLWM will continue operating for an additional 5 seconds, if no other function requires blower motor BLWM operation.

#### 4. Heat Pump Mode

When installed with a heat pump, the furnace control automatically changes the timing sequence to avoid long blower off times during demand defrost cycles. When the R-to-W-and-Y or R-to-W-and-Y-and-G circuits are energized the furnace control CPU will continue to turn on the blower motor BLWM at HEAT speed, and begin a heating cycle. The blower motor BLWM will remain on until the end of the prepurge period, then shut off for 24 seconds then come back on at HEAT speed. When the W input signal disappears, the furnace control begins a normal inducer post-purge period and the blower switches to COOL speed after a 3 second delay. If the R-to-W-and-Y-and-G signals disappear at the same time, the blower motor BLWM will remain on for the selected blower-OFF delay period. If the R-to-W-and-Y signals disappear, leaving the G signal, the blower motor BLWM will continue running the blower motor BLWM at HEAT speed after the selected blower-OFF delay period is completed.

#### COMPONENT TEST

**NOTE:** The furnace control component test allows all components to run for a short time; except the gas valve and humidifier terminal HUM are not energized for safety reasons. The EAC-1 terminal is energized when the blower is energized. This feature helps diagnose a system problem in case of a component failure. The component test feature will not operate if any thermostat signal is present at the control and not until all time delays are completed.

To Begin Component Self-Test:

#### ⚠ WARNING

##### ELECTRICAL SHOCK HAZARD

Failure to follow this warning could result in electrical shock, personal injury, or death.

Blower access panel door switch opens 115-v power to control center. No component operation can occur. Caution must be taken when manually closing this switch for service purposes.

1. Remove blower access door.
2. Disconnect the thermostat R lead from furnace control.
3. Manually close blower door switch.
4. For approximately 2 sec, short (jumper) the COM-24v terminal on control to the TEST/TWIN 3/16-inch quick-connect terminal on control until the LED goes out. Remove jumper from terminals. (See Fig. 33.)

**NOTE:** If TEST/TWIN and COM-24v terminals are jumpered longer than 2 sec, LED will flash rapidly and ignore component test request.

Component test sequence is as follows:

- a. LED will display previous status code 4 times.
  - b. Inducer motor starts and continues to run until Step g of component test sequence.
  - c. After 7 seconds the hot surface igniter is energized for 15 sec, then off.
  - d. Blower motor operates on HEAT speed for 10 sec.
  - e. Blower motor operates on COOL speed for 10 sec.
  - f. Inducer motor stops.
5. Reconnect R lead to furnace control, remove tape from blower door switch, and re-install blower door.
  6. Operate furnace per instruction on outer door.

7. Verify furnace shut down by lowering thermostat setting below room temperature.
8. Verify that furnace restarts by raising thermostat setting above room temperature.

#### Step 5—Adjustments

##### SET GAS INPUT RATE

Furnace gas input rate on rating plate is for installations at altitudes up to 2000 ft.

In the U.S.A., the input ratings for altitudes above 2000 ft must be reduced by 2 percent for each 1000 ft above sea level.

In Canada, the input ratings must be derated by 5 percent for altitudes of 2000 ft to 4500 ft above sea level.

Furnace input rate must be within 2 percent of input on furnace rating plate adjusted for altitude.

1. Determine natural gas orifice size and manifold pressure for correct input.
  - a. Obtain average gas heat value (at installed altitude) from local gas supplier.
  - b. Obtain average gas specific gravity from local gas supplier.
  - c. Verify furnace model. Table 11 can only be used for model 58MSA furnaces.
  - d. Find installation altitude in Table 11.

**NOTE:** For Canadian altitudes of 2001 to 4500 ft, use U.S.A. altitudes of 2001 to 3000 ft in Table 11.

- e. Find closest natural gas heat value and specific gravity on Table 11.
- f. Follow heat value and specific gravity lines to point of intersection to find orifice size and manifold pressure settings for proper operation.

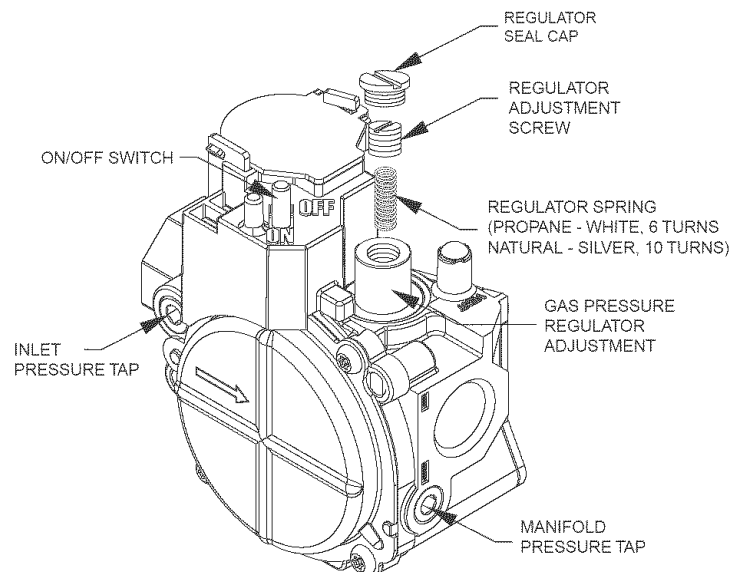

Fig. 46—Redundant Automatic Gas Valve

A03142

**Table 11—Model 58MSA Orifice Size and Manifold Pressure for Correct Input  
(Tabulated Data Based on 20,000 Btuh per Burner, Derated 2% for Each 1000 Ft Above Sea Level)\***

ALTITUDE RANGE (FT)		AVG GAS HEAT VALUE AT ALTITUDE (BTU/CU FT)	SPECIFIC GRAVITY OF NATURAL GAS									
			0.58		0.60		0.62		0.64		0.66	
			Orifice No.	Manifold Pressure	Orifice No.	Manifold Pressure	Orifice No.	Manifold Pressure	Orifice No.	Manifold Pressure	Orifice No.	Manifold Pressure
U.S.A. and Canada	0 to 2000	850	43	3.7	43	3.8	42	3.2	42	3.3	42	3.4
		875	43	3.5	43	3.6	43	3.7	43	3.8	42	3.2
		900	44	3.7	43	3.4	43	3.5	43	3.6	43	3.7
		925	44	3.5	44	3.7	44	3.8	43	3.4	43	3.5
		950	44	3.4	44	3.5	44	3.6	44	3.7	44	3.8
		975	44	3.2	44	3.3	44	3.4	44	3.5	44	3.6
		1000	45	3.7	45	3.8	44	3.2	44	3.4	44	3.5
		1025	45	3.5	45	3.6	45	3.7	44	3.2	44	3.3
		1050	45	3.3	45	3.4	45	3.6	45	3.7	45	3.8
		1075	45	3.2	45	3.3	45	3.4	45	3.5	45	3.6
0% derate	1100	47	3.6	47	3.7	45	3.2	45	3.4	45	3.5	
U.S.A. and Canada	U.S.A. Altitudes 2001 to 3000 or Canada Altitudes 2001 to 4500	775	43	3.8	42	3.2	42	3.3	42	3.4	42	3.5
		800	43	3.5	43	3.7	43	3.8	42	3.2	42	3.3
		825	44	3.8	43	3.4	43	3.6	43	3.7	43	3.8
		850	44	3.6	44	3.7	44	3.8	43	3.5	43	3.6
		875	44	3.4	44	3.5	44	3.6	44	3.7	43	3.4
		900	44	3.2	44	3.3	44	3.4	44	3.5	44	3.6
		925	45	3.7	45	3.8	44	3.2	44	3.3	44	3.4
		950	45	3.5	45	3.6	45	3.7	45	3.8	44	3.3
		975	45	3.3	45	3.4	45	3.5	45	3.6	45	3.8
		5% derate	1000	45	3.1	45	3.2	45	3.4	45	3.5	45
1025	45	3.0	45	3.1	45	3.2	45	3.3	45	3.4		
U.S.A. Only	3001 to 4000	750	43	3.7	43	3.8	42	3.3	42	3.4	42	3.5
		775	43	3.5	43	3.6	43	3.7	43	3.8	42	3.2
		800	44	3.7	43	3.4	43	3.5	43	3.6	43	3.7
		825	44	3.5	44	3.6	44	3.8	43	3.4	43	3.5
		850	44	3.3	44	3.4	44	3.5	44	3.7	44	3.8
		875	45	3.8	44	3.2	44	3.3	44	3.5	44	3.6
		900	45	3.6	45	3.7	45	3.8	44	3.3	44	3.4
		925	45	3.4	45	3.5	45	3.6	45	3.7	44	3.2
		950	45	3.2	45	3.3	45	3.4	45	3.5	45	3.7
		7% derate	975	45	3.0	45	3.2	45	3.3	45	3.4	45
1000	45	2.9	45	3.0	45	3.1	45	3.2	45	3.3		

\*Orifice numbers 45 are factory installed.

Percents of derate are based on midpoints of U.S. altitude ranges.



**Table 11—Model 58MSA Orifice Size and Manifold Pressure for Correct Input Continued**  
 (Tabulated Data Based on 20,000 Btuh per Burner, Derated 2% for Each 1000 Ft Above Sea Level)\*

ALTITUDE RANGE (FT)		AVG GAS HEAT VALUE AT ALTITUDE (BTU/CU FT)	SPECIFIC GRAVITY OF NATURAL GAS									
			0.58		0.60		0.62		0.64		0.66	
			Orifice No.	Manifold Pressure	Orifice No.	Manifold Pressure	Orifice No.	Manifold Pressure	Orifice No.	Manifold Pressure	Orifice No.	Manifold Pressure
U.S.A. Only	4001	725	43	3.7	43	3.8	42	3.2	42	3.3	42	3.4
		750	43	3.4	43	3.5	43	3.7	43	3.8	42	3.2
		775	44	3.7	44	3.8	43	3.4	43	3.5	43	3.7
		800	44	3.5	44	3.6	44	3.7	44	3.8	43	3.4
		825	44	3.2	44	3.4	44	3.5	44	3.6	44	3.7
	to	850	45	3.7	45	3.8	44	3.3	44	3.4	44	3.5
	875	45	3.5	45	3.6	45	3.7	44	3.2	44	3.3	
	5000	900	45	3.3	45	3.4	45	3.5	45	3.6	45	3.8
	9% derate	925	45	3.1	45	3.2	45	3.3	45	3.4	45	3.6
		950	45	3.0	45	3.1	45	3.2	45	3.3	45	3.4
U.S.A. Only	5001	700	43	3.6	43	3.7	42	3.2	42	3.3	42	3.4
		725	43	3.4	43	3.5	43	3.6	43	3.7	43	3.8
		750	44	3.6	44	3.7	43	3.4	43	3.5	43	3.6
		775	44	3.4	44	3.5	44	3.6	44	3.7	43	3.4
		800	44	3.2	44	3.3	44	3.4	44	3.5	44	3.6
		825	45	3.6	45	3.7	44	3.2	44	3.3	44	3.4
	to	850	45	3.4	45	3.5	45	3.6	45	3.8	44	3.2
	6000	875	45	3.2	45	3.3	45	3.4	45	3.6	45	3.7
		900	45	3.0	45	3.1	45	3.3	45	3.4	45	3.5
		925	45	2.9	45	3.0	45	3.1	45	3.2	45	3.3
	11% derate	950	45	2.7	45	2.8	45	2.9	45	3.0	45	3.1
		975	45	2.6	45	2.7	45	2.8	45	2.9	45	2.9
	1000	45	2.5	45	2.5	45	2.6	45	2.7	45	2.8	
U.S.A. Only	6001	650	42	3.2	42	3.3	42	3.4	42	3.5	42	3.6
		675	43	3.6	43	3.7	43	3.8	42	3.2	42	3.3
		700	44	3.8	43	3.4	43	3.6	43	3.7	43	3.8
		725	44	3.6	44	3.7	44	3.8	43	3.4	43	3.5
		750	44	3.3	44	3.4	44	3.6	44	3.7	44	3.8
	to	775	45	3.8	44	3.2	44	3.3	44	3.4	44	3.5
	800	45	3.5	45	3.7	45	3.8	44	3.2	44	3.3	
	7000	825	45	3.3	45	3.4	45	3.6	45	3.7	45	3.8
	13% derate	850	45	3.1	45	3.2	45	3.4	45	3.5	45	3.6
		875	45	3.0	45	3.1	45	3.2	45	3.3	45	3.4

\*Orifice numbers 45 are factory installed.

Percents of derate are based on midpoints of U.S. altitude ranges.

**Table 11—Model 58MSA Orifice Size and Manifold Pressure for Correct Input Continued**  
 (Tabulated Data Based on 20,000 Btuh per Burner, Derated 2% for Each 1000 Ft Above Sea Level)\*

ALTITUDE RANGE (FT)		AVG GAS HEAT VALUE AT ALTITUDE (BTU/CU FT)	SPECIFIC GRAVITY OF NATURAL GAS										
			0.58		0.60		0.62		0.64		0.66		
			Orifice No.	Manifold Pressure	Orifice No.	Manifold Pressure	Orifice No.	Manifold Pressure	Orifice No.	Manifold Pressure	Orifice No.	Manifold Pressure	
U.S.A. Only	7001	625	43	3.8	42	3.3	42	3.4	42	3.5	42	3.6	
		650	43	3.5	43	3.7	43	3.8	42	3.2	42	3.3	
		675	44	3.8	43	3.4	43	3.5	43	3.6	43	3.7	
		700	44	3.5	44	3.6	44	3.8	43	3.4	43	3.5	
	to	725	44	3.3	44	3.4	44	3.5	44	3.6	44	3.7	
		750	45	3.7	45	3.8	44	3.3	44	3.4	44	3.5	
	8000	775	45	3.5	45	3.6	45	3.7	45	3.8	44	3.3	
		800	45	3.3	45	3.4	45	3.5	45	3.6	45	3.7	
15% derate	825	45	3.1	45	3.2	45	3.3	45	3.4	45	3.5		
	850	45	2.9	45	3.0	45	3.1	45	3.2	45	3.3		
U.S.A. Only	8001	600	43	3.8	42	3.3	42	3.4	42	3.5	42	3.6	
		625	43	3.5	43	3.6	43	3.8	42	3.2	42	3.3	
		650	44	3.7	43	3.4	43	3.5	43	3.6	43	3.7	
		675	44	3.5	44	3.6	44	3.7	44	3.8	43	3.4	
	to	700	44	3.2	44	3.3	44	3.4	44	3.6	44	3.7	
		725	45	3.6	45	3.8	44	3.2	44	3.3	44	3.4	
	9000	750	45	3.4	45	3.5	45	3.6	45	3.8	44	3.2	
		775	45	3.2	45	3.3	45	3.4	45	3.5	45	3.6	
	17% derate	800	45	3.0	45	3.1	45	3.2	45	3.3	45	3.4	
	U.S.A. Only	9001	575	43	3.8	42	3.2	42	3.3	42	3.5	42	3.6
			600	43	3.5	43	3.6	43	3.7	42	3.2	42	3.3
625			44	3.7	44	3.8	43	3.5	43	3.6	43	3.7	
650			44	3.4	44	3.5	44	3.7	44	3.8	43	3.4	
to		675	45	3.8	44	3.3	44	3.4	44	3.5	44	3.6	
		700	45	3.6	45	3.7	45	3.8	44	3.3	44	3.4	
10,000		725	45	3.3	45	3.4	45	3.6	45	3.7	45	3.8	
		750	45	3.1	45	3.2	45	3.3	45	3.4	45	3.5	
19% derate		775	45	2.9	45	3.0	45	3.1	45	3.2	45	3.3	

\*Orifice numbers 45 are factory installed.

Percents of derate are based on U.S. altitude ranges.

EXAMPLE: (0—2000 altitude)  
 Heating value = 1050 Btu/cu ft  
 Specific gravity = 0.62  
 Therefore: Orifice No. 45  
 Manifold pressure 3.6-in. wc  
 \* Furnace is shipped with No. 45 orifices. In this example all main burner orifices are the correct size and do not need to be changed to obtain the proper input rate.

Check and verify burner orifice size in furnace. NEVER ASSUME ORIFICE SIZE; ALWAYS CHECK AND VERIFY.

2. Adjust manifold pressure to obtain input rate.  
**NOTE:** Manifold pressure must always be measured with burner enclosure front REMOVED. Gas meter must always be clocked with burner enclosure front INSTALLED.

- a. Remove burner enclosure front.
- b. Remove cap that conceals adjustment screw for gas valve regulator. (See Fig. 46.)
- c. Jumper R and W thermostat connections on control to start furnace operation.
- d. Turn adjusting screw, counterclockwise (out) to decrease manifold pressure or clockwise (in) to increase manifold pressure.

**NOTE:** This furnace has been approved for a manifold pressure of 3.2 in. wc to 3.8 in. wc when installed at altitudes up to 2000 ft. For altitudes above 2000 ft, the manifold pressure can be adjusted from 2.0 in. wc to 3.8 in. wc. If manifold pressure is outside this range, change burner orifices to obtain pressure in this range.

**CAUTION**

**UNIT DAMAGE HAZARD**

Failure to follow this caution may result in reduced furnace life.  
 DO NOT bottom out gas valve regulator adjusting screw. This can result in unregulated manifold pressure and result in excess overfire and heat exchanger failures.

**NOTE:** If orifice hole appears damaged or it is suspected to have been redrilled, check orifice hole with a numbered drill bit of correct size. Never redrill an orifice. A burr-free and squarely aligned orifice hole is essential for proper flame characteristics.

- e. Replace gas valve regulator adjustment screw cap.
- f. Replace burner enclosure front and verify adjusted gas input rate using method outlined in item 3.

**CAUTION**

**UNIT DAMAGE HAZARD**

Failure to follow this caution may result in component damage due to flame impingement of burners and heat exchangers.  
 DO NOT redrill orifices. Improper drilling (burrs, out-of-round holes, etc.) can cause excessive burner noise and misdirection of burner flames. (See Fig. 47.)

- g. Look through sight glass in burner enclosure and check burner flame. Burner flame should be clear blue, almost transparent. (See Fig. 48.)
- h. Remove jumper from R and W.

3. Verify natural gas input rate by clocking gas meter.

**NOTE:** Be sure all pressure tubing, combustion-air and vent pipes, and burner enclosure front are in place when checking input by clocking gas meter.

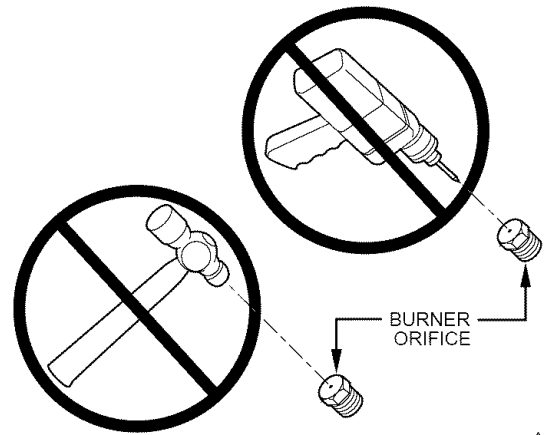

Fig. 47—Burner Orifice

A93059

- a. Calculate high-altitude adjustment (if required).

United States

At altitudes above 2000 ft, this furnace has been approved for a 2% derate for each 1000 ft above sea level. See Table 12 for derate multiplier factor.

EXAMPLE: 100,000 Btuh input furnace installed at 4300 ft.			
Furnace Input Rate at Sea Level	X	Derate Multiplier Factor	= Furnace Input Rate at Installation Altitude
100,000	X	0.91	= 91,000

Canada

At installation altitudes from 2001 to 4500 ft, this furnace must be derated 5% by an authorized Gas Conversion Station. To determine correct input rate for altitude, see example above and use 0.95 as derate multiplier factor.

- b. Reinstall burner box cover.
- c. Gas valve regulator seal cap MUST be installed.
- d. Turn off all other gas appliances and pilots.
- e. Start furnace and let operate for 3 minutes.
- f. Measure time (in sec) for gas meter test dial to complete 1 revolution.
- g. Refer to Table 13 for cu ft of gas per hr.
- h. Multiply gas rate (cu ft/hr) X heating value (Btu/cu ft) using natural gas heating value from local gas utility/supplier.

Table 12—Altitude Derate Multiplier for U.S.A.

ALTITUDE (FT)	% OF DERATE	DERATE MULTIPLIER FACTOR FOR U.S.A.*
0—2000	0	1.00
2001—3000	4—6	0.95
3001—4000	6—8	0.93
4001—5000	8—10	0.91
5001—6000	10—12	0.89
6001—7000	12—14	0.87
7001—8000	14—16	0.85
8001—9000	16—18	0.83
9001—10,000	18—20	0.81

\* Derate multiplier factor is based on midpoint altitude for altitude range.

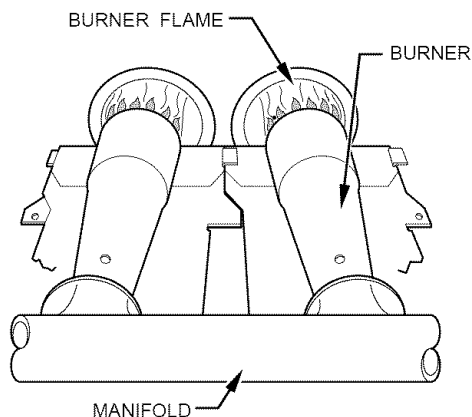

Fig. 48—Burner Flame

A89020

Table 13—Gas Rate (Cu Ft/Hr)

SECONDS FOR 1 REVOLUTION	SIZE OF TEST DIAL			SECONDS FOR 1 REVOLUTION	SIZE OF TEST DIAL		
	1 cu ft	2 cu ft	5 cu ft		1 cu ft	2 cu ft	5 cu ft
10	360	720	1800	50	72	144	360
11	327	655	1636	51	71	141	355
12	300	600	1500	52	69	138	346
13	277	555	1385	53	68	136	340
14	257	514	1286	54	67	133	333
15	240	480	1200	55	65	131	327
16	225	450	1125	56	64	129	321
17	212	424	1059	57	63	126	316
18	200	400	1000	58	62	124	310
19	189	379	947	59	61	122	305
20	180	360	900	60	60	120	300
21	171	343	857	62	58	116	290
22	164	327	818	64	56	112	281
23	157	313	783	66	54	109	273
24	150	300	750	68	53	106	265
25	144	288	720	70	51	103	257
26	138	277	692	72	50	100	250
27	133	267	667	74	48	97	243
28	129	257	643	76	47	95	237
29	124	248	621	78	46	92	231
30	120	240	600	80	45	90	225
31	116	232	581	82	44	88	220
32	113	225	563	84	43	86	214
33	109	218	545	86	42	84	209
34	106	212	529	88	41	82	205
35	103	206	514	90	40	80	200
36	100	200	500	92	39	78	196
37	97	195	486	94	38	76	192
38	95	189	474	96	38	75	188
39	92	185	462	98	37	74	184
40	90	180	450	100	36	72	180
41	88	176	439	102	35	71	178
42	86	172	429	104	35	69	173
43	84	167	419	106	34	68	170
44	82	164	409	108	33	67	167
45	80	160	400	110	33	65	164
46	78	157	391	112	32	64	161
47	76	153	383	116	31	62	155
48	75	150	375	120	30	60	150
49	73	147	367	124	29	58	145

EXAMPLE: (0—2000 ft altitude)  
 Furnace input from rating plate is 100,000 Btuh.  
 Btu heating input = Btu/cu ft X cu ft/hr  
 Heating value of gas = 975 Btu/cu ft  
 Time for 1 revolution of 2-cu ft dial = 70 sec  
 Gas rate = 103 cu ft/hr (from Table 11)  
 Btu heating input = 103 X 975 = 100,425 Btuh  
 In this example, the orifice size and manifold pressure adjustment is within ±2 percent of the furnace input rate.

SET TEMPERATURE RISE

**CAUTION**

**UNIT DAMAGE HAZARD**  
 Failure to follow this caution may result in overheating the heat exchangers or condensing flue gases in heat exchanger areas not designed for condensate.  
 Temperature rise must be within limits specified on furnace rating plate. Recommended operation is at midpoint of rise range or slightly above.

Determine and adjust air temperature rise as follows:

1. Place thermometers in return and supply ducts as close to furnace as possible. Be sure thermometers do not see heat exchanger so that radiant heat does not affect readings. This practice is particularly important with straight-run ducts.
2. When thermometer readings stabilize, subtract return-air temperature from supply-air temperature to determine air temperature rise.
3. Adjust temperature rise by adjusting blower speed. Increase blower speed to reduce temperature rise. Decrease blower speed to increase temperature rise.

**WARNING**

**ELECTRICAL SHOCK HAZARD**  
 Failure to follow this warning could result in personal injury or death.  
 Disconnect 115-v electrical power before changing speed tap.

4. To change blower motor speed selections for heating mode, remove blower motor lead from control center HEAT terminal. (See Fig. 33.) Select desired blower motor speed lead from 1 of the other motor leads and relocate it to HEAT terminal. See Table 14 for lead color identification. Reconnect original lead on SPARE terminal.

Follow this same procedure for proper selection of COOL speed selection.

BLOWER OFF DELAY (HEAT MODE)

The blower off delay has 4 adjustable settings from 90 sec to 180 sec. (See Table 15.) The blower off delay jumpers are located on the furnace control board. (See Fig. 33.) To change the blower off

Table 14—Speed Selector

COLOR	SPEED	FACTORY-SHIPPED CONNECTION
Black	High	Cool
Yellow (When Present)	Medium High	Spare
Blue	Medium Low	Heat
Red	Low	Spare
White	Common	Com

**Table 15—Blower Off Delay Setup Position**

PINS	1 AND 2	2 AND 3	3 AND 4	4 AND 5
Time (in sec)	90	120	150	180

delay setting, move the jumper from one set of pins on the control board to the pins used for the desired blower off delay. Factory blower off delay setting is 120 sec.

**SET THERMOSTAT HEAT ANTICIPATOR**

When using a nonelectronic thermostat, the thermostat heat anticipator must be set to match amp draw of components in R-W circuit. Accurate amp draw measurements can be obtained at thermostat subbase terminals R and W. Fig. 49 illustrates an easy method of obtaining these measurements. The amp reading should be taken after blower motor has started and furnace is heating. Connect ammeter wires as shown in Fig. 49. The thermostat anticipator should NOT be in the circuit while measuring current. If thermostat has no subbase, the thermostat must be disconnected from R and W wires during current measurement. See thermostat manufacturer's instructions for adjusting heat anticipator and for varying heating cycle length.

For an electronic thermostat, set cycle rate for 3 cycles per hour.

**CHECK SAFETY CONTROLS**

This section covers the safety controls that must be checked before the installation is complete. The flame sensor, gas valve, and pressure switch were all checked in the Start-up procedure section as part of normal operation.

**Step 1—Check Primary Limit Control**

This control shuts off gas control system and energizes air-circulating blower motor if furnace overheats. Recommended method of checking this limit control is to gradually block off return air after furnace has been operating for a period of at least 5 minutes. As soon as limit control has shut off burners, return-air opening should be unblocked to permit normal air circulation. By using this method to check limit control, it can be established that limit is functioning properly and operates if there is a restricted return-air duct or motor failure. If limit control does not function during this test, cause must be determined and corrected.

**Step 2—Check Pressure Switch**

This control proves operation of draft inducer. Check switch operation as follows:

1. Turn off 115-v power to furnace.

2. Remove main furnace door and disconnect inducer motor lead wires from wire harness.
3. Turn on 115-v power to furnace.
4. Set thermostat to "call for heat" and wait 1 minute. When pressure switch is functioning properly, hot surface igniter should NOT glow, and control status code LED flashes status code 31 fault. If hot surface igniter glows when inducer motor is disconnected, shut furnace down immediately. Determine reason pressure switch did not function properly and correct condition.
5. Turn off 115-v power to furnace.
6. Reconnect inducer motor leads, reinstall main furnace door, and turn on 115-v power supply.

**CHECKLIST**

1. Put away tools and instruments. Clean up debris.
2. Verify flame rollout manual reset switch has continuity.
3. Verify that blower and main access doors are properly installed.
4. Cycle test furnace with room thermostat.
5. Check operation of accessories per manufacturer's instructions.
6. Review User's Guide with owner.
7. Leave literature packet near furnace.

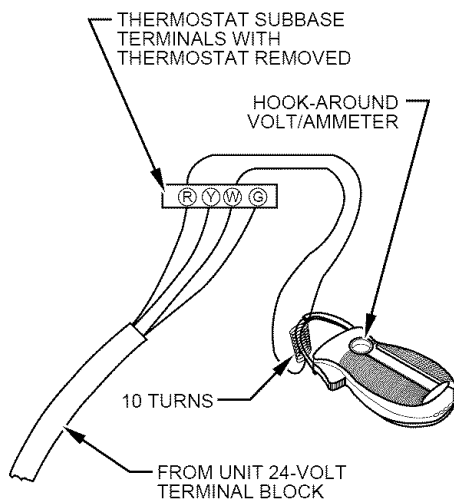

EXAMPLE:  $\frac{5.0 \text{ AMPS ON AMMETER}}{10 \text{ TURNS AROUND JAWS}} = 0.5 \text{ AMPS FOR THERMOSTAT SETTING}$

A80201

**Fig. 49—Amp Draw Check with Ammeter**

## CHECKLIST—INSTALLATION

### LOAD CALCULATION

\_\_\_\_\_ Heating Load (Btuh)  
\_\_\_\_\_ Cooling Load (Btuh)  
\_\_\_\_\_ Furnace Model Selection

### VENT PIPING

#### Termination Location

\_\_\_\_\_ Roof or Sidewall  
\_\_\_\_\_ Vent Pipe Length  
\_\_\_\_\_ Vent Pipe Elbow Quantity  
\_\_\_\_\_ Pipe Diameter Determined from Sizing Table  
\_\_\_\_\_ Pipe Sloped To Furnace

#### Pipe Insulation

\_\_\_\_\_ Over Ceilings  
\_\_\_\_\_ Low-Ambient Exposed Pipes

### Condensate Drain

\_\_\_\_\_ Unit Level or Pitched Forward  
\_\_\_\_\_ Internal Tubing Connections Free of Kinks and Traps  
\_\_\_\_\_ External Drain Connection Leak Tight and Sloped  
\_\_\_\_\_ Condensate Trap Primed before Start-Up  
\_\_\_\_\_ Heat Tape Installed if Required

### CHECKLIST—START-UP

\_\_\_\_\_ Gas Input Rate (Set Within 2 percent of Rating Plate)  
\_\_\_\_\_ Temperature Rise Adjusted

### Thermostat Anticipator

\_\_\_\_\_ Anticipator Setting Adjusted or  
\_\_\_\_\_ Cycle Rate (3 Cycles per Hr) Selected

### Safety Controls Check Operation

\_\_\_\_\_ Primary Limit  
\_\_\_\_\_ Pressure Switch



---

**Manufacturer reserves the right to discontinue, or change at any time, specifications or designs without notice and without incurring obligations.**