



Installation, Start-Up, and Service Instructions

CONTENTS

	Page
SAFETY CONSIDERATIONS	1,2
INSTALLATION	2-19
Step 1 — Plan for Unit Location	2
Step 2 — Provide Unit Support	2
• ROOF CURB	
• ALTERNATE UNIT SUPPORT	
Step 3 — Rig and Place Unit	2
• INSTALLATION ONTO CURB	
• SLAB MOUNT (Horizontal Units Only)	
Step 4 — Field Fabricate Ductwork	4
Step 5 — Make Unit Duct Connections	4
Step 6 — Install Flue Hood and Inlet Hood	7
Step 7 — Install External Trap for Condensate Drain	8
Step 8 — Install Gas Piping	9
Step 9 — Make Electrical Connections	9
• FIELD POWER SUPPLY	
• FIELD CONTROL WIRING	
Step 10 — Optional EconoMiSer IV	13
Step 11 — Install All Accessories	19
PRE-START-UP	20
START-UP	20-36
SERVICE	37-45
Cleaning	37
Lubrication	38
Evaporator Fan Service and Replacement	39
Evaporator Fan Performance Adjustment	39
Evaporator Fan Belt Tension Adjustment	39
Condenser-Fan Adjustment	39
Verify Sensor Performance	40
Economizer Operation During Power Failure	40
Evacuation	40
Refrigerant Charge	40
Gas Valve Adjustment	42
High Altitude	42
LP (Liquid Propane) Gas Use	42
Main Burners	42
Filter Drier	43
Protective Devices	43
Relief Devices	43
Control Circuit 24-V	43
Replacement Parts	43
Diagnostic LEDs	43
TROUBLESHOOTING	46-49
Unit Troubleshooting	46
EconoMiSer IV Troubleshooting	48
Phase Loss Protection	49
UNIT START-UP CHECKLIST	CL-1

SAFETY CONSIDERATIONS

Installation and servicing of air-conditioning equipment can be hazardous due to system pressure and electrical components. Only trained and qualified service personnel should install, repair, or service air-conditioning equipment.

Untrained personnel can perform the basic maintenance functions of cleaning coils and filters and replacing filters. All other operations should be performed by trained service personnel. When working on air-conditioning equipment, observe precautions in the literature, tags and labels attached to the unit, and other safety precautions that may apply.

Follow all safety codes. Wear safety glasses and work gloves. Use quenching cloth for unbrazing operations. Have fire extinguishers available for all brazing operations.

⚠ WARNING

Before performing service or maintenance operations on unit, turn off main power switch to unit. Electrical shock could cause personal injury.

⚠ CAUTION

Puron (R-410A) refrigerant systems operate at higher pressures than standard R-22 systems. Do not use R-22 service equipment or components on Puron refrigerant equipment. If service equipment is not rated for Puron refrigerant, equipment damage or personal injury may result.

⚠ WARNING

1. Improper installation, adjustment, alteration, service, or maintenance can cause property damage, personal injury, or loss of life. Refer to the User's Information Manual provided with this unit for more details.
2. Do not store or use gasoline or other flammable vapors and liquids in the vicinity of this or any other appliance.

What to do if you smell gas:

1. DO NOT try to light any appliance.
2. DO NOT touch any electrical switch, or use any phone in your building.
3. IMMEDIATELY call your gas supplier from a neighbor's phone. Follow the gas supplier's instructions.
4. If you cannot reach your gas supplier, call the fire department.

⚠ WARNING

Disconnect gas piping from unit when pressure testing at pressure greater than 0.5 psig. Pressures greater than 0.5 psig will cause gas valve damage resulting in hazardous condition. If gas valve is subjected to pressure greater than 0.5 psig, it *must* be replaced before use. When pressure testing field-supplied gas piping at pressures of 0.5 psig or less, a unit connected to such piping must be isolated by closing the manual gas valve(s).

IMPORTANT: Units have high ambient operating limits. If limits are exceeded, the units will automatically lock the compressor out of operation. Manual reset will be required to restart the compressor.

INSTALLATION

Step 1 — Plan for Unit Location — Select a location for the unit and its support system (curb or other) that provides minimum clearances required for safety, unit performance and service access below, around and above unit as specified in unit drawings. Consider also the effect of adjacent units.

Do not install unit in an indoor location. Do not locate air inlets near exhaust vents or other sources of contaminated air. For proper unit operation, adequate combustion and ventilation air must be provided in accordance with Section 5.3 (Air for Combustion and Ventilation) of the National Fuel Gas Code, ANSI Z223.1 (American National Standards Institute). Although unit is weatherproof, guard against water from higher level runoff and overhangs.

Locate mechanical draft system flue assembly at least 4 ft from any opening through which combustion products could enter the building, and at least 4 ft from any adjacent building (or per local code). Locate the flue assembly at least 10 ft (or per local code) from an adjacent unit's fresh air intake hood if within 3 ft of same elevation. When unit is located adjacent to public walkways, flue assembly must be at least 7 ft above grade.

Select a unit mounting system that provides adequate height to allow installation of condensate trap per requirements. Refer to Step 7 — Install External Trap for Condensate Drain for required trap dimensions.

ROOF MOUNT — Check building codes for weight distribution requirements. Unit operating weight is shown in Table 1.

Step 2 — Provide Unit Support

ROOF CURB — Assemble or install accessory roof curb in accordance with instructions shipped with this accessory. See Fig. 1. Install insulation, cant strips, roofing, and counter flashing as shown. Ductwork can be installed to roof curb before unit is set in place. Ductwork must be attached to curb and not to the unit. Curb must be level. This is necessary to permit unit drain to function properly. Unit leveling tolerance is $\pm 1/16$ in. per linear ft in any direction. Refer to Accessory Roof Curb Installation Instructions for additional information as required. When accessory roof curb is used, unit may be installed on class A, B, or C roof covering material. Carrier roof curb accessories are for flat roofs or slab mounting.

IMPORTANT: The gasketing of the unit to the roof curb is critical for a watertight seal. Install gasket with the roof curb as shown in Fig. 1. Improperly applied gasket can also result in air leaks and poor unit performance. Do not slide unit to position on roof curb.

ALTERNATE UNIT SUPPORT — When a curb cannot be used, install unit on a noncombustible surface. Support unit with sleepers, using unit curb support area. If sleepers cannot be used, support long sides of unit with a minimum of 3 equally spaced 4-in. x 4-in. pads on each side.

Step 3 — Rig and Place Unit — Inspect unit for transportation damage. See Table 1 for physical data. File any claim with transportation agency.

▲ CAUTION

All panels must be in place when rigging. Damage to unit may result.

Do not drop unit; keep upright. Use spreader bars over unit to prevent sling or cable damage. Rollers may be used to move unit across a roof. Level by using unit rail as a reference; leveling tolerance is $\pm 1/16$ in. per linear ft in any direction. See Fig. 2 for additional information. Unit rigging weight is shown in Fig. 2.

Rigging holes are provided in the unit base rails as shown in Fig. 2. Refer to rigging instructions on unit.

INSTALLATION ONTO CURB — The 48PG units are designed to fit on the accessory full perimeter curb. Correct placement of the unit onto the curb is critical to operating performance. To aid in correct positioning, place unit on roof curb to maintain $1/4$ -in. gap between the inside of rail and roof curb on long sides and a $1/2$ -in. gap between the inside of rail and roof curb on both duct and condenser ends. Refer to Fig. 1 and 3, to assure proper duct opening alignment.

NOTE: Before positioning unit onto curb, refer to Step 7 — Install External Trap for Condensate Drain on page 8 for clearances.

▲ CAUTION

Do not slide unit to position it when it is sitting on the curb. Curb gasketing material may be damaged and leaks may result.

SLAB MOUNT (Horizontal Units Only) — Provide a level concrete slab that extends a minimum of 6-in. beyond unit cabinet. Install a gravel apron in front of condenser-coil air inlet to prevent grass and foliage from obstructing airflow.

NOTE: Horizontal units may be installed on a roof curb if required.

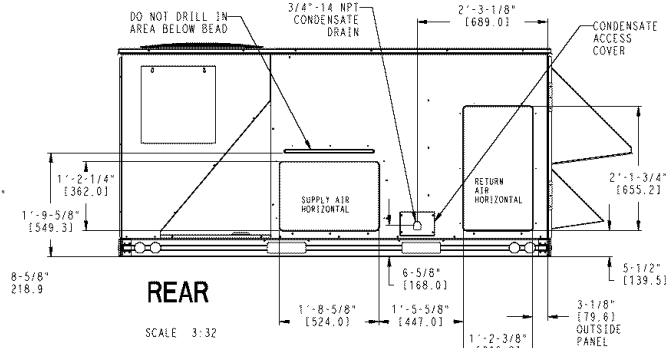
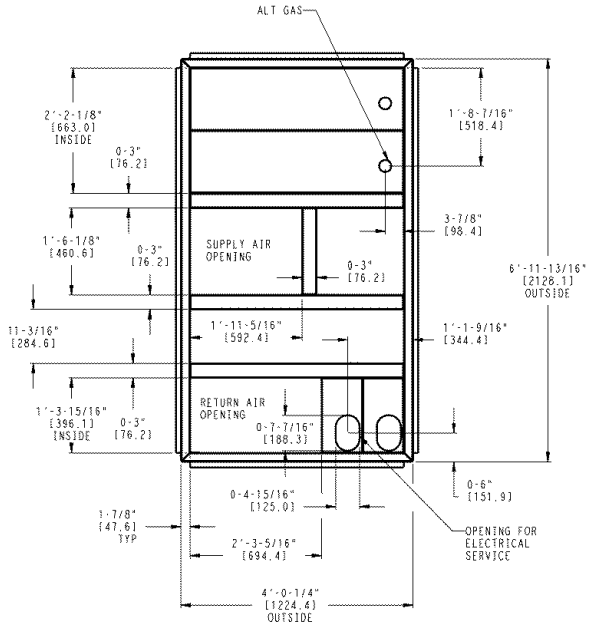

UNIT SIZE	"C"	CONNECTOR ACCESSORY PACKAGE
48 PG		
03-07	1/2" NPT	CRGASPLT005A00

UNIT SIZE	"A"	ROOF CURB ACCESSORY
48 PG		
03-07	1'-2" [356] 2'-0" [610]	CRRFCURB020A00 CRRFCURB032A00

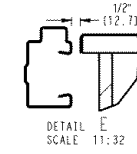
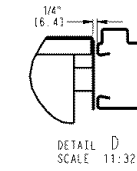

- NOTES:
- 1 ROOF CURB ACCESSORY IS SHIPPED UNASSEMBLED.
 - 2 INSULATED PANELS.
 - 3 DIMENSIONS IN [] ARE IN MILLIMETERS.
 - 4 ROOF CURB GALVANIZED STEEL.
 - 5 ATTACH DUCTWORK TO CURB (FLANGES ON DUCT REST ON CURB)
 - 6 SERVICE CLEARANCE 4 FT ON EACH SIDE
 - 7 GAS SERVICE PLATE IS PART OF A SEPARATELY SHIPPED ACCESSORY PACKAGE.
 - 8 GAS SERVICE PLATE CAN BE USED WITH EITHER ACCESSORY ROOF CURB.
 - 9 BOLT HEADS TO BE ON INSIDE OF FLANGE. CLEARANCE IS (13) 0'-0-7/16" TYP ALL CORNERS.
- ➔ DIRECTION OF AIRFLOW.

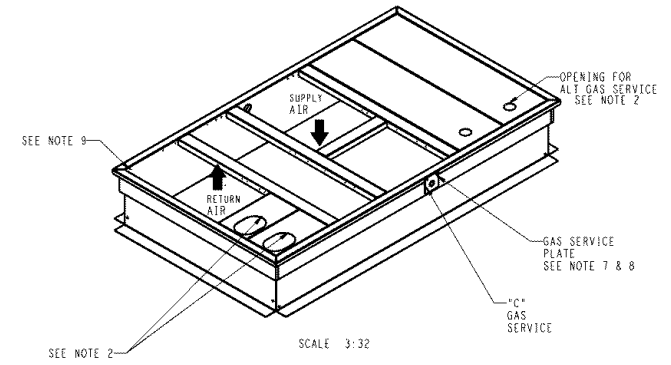
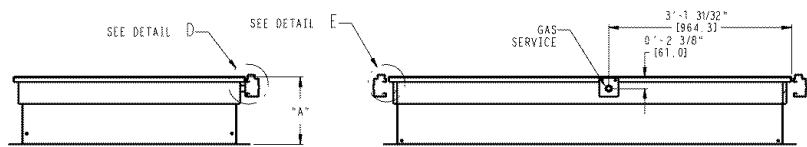
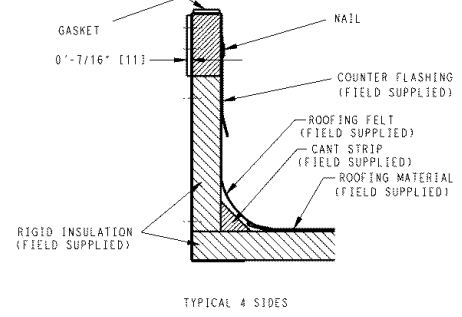

Fig. 1 — Roof Curb Details

**⚠ CAUTION-NOTICE TO RIGGERS:
ACCESS PANEL MUST BE IN PLACE WHEN RIGGING.**

Hook rigging shackles through holes in base rail, as shown in Detail A. Holes in base rails are centered around the unit center of gravity. Use wooden top skid, when rigging, to prevent rigging straps from damaging unit.

UNIT SIZE	A		B		C		D		E		MAX. WEIGHT	
	in.	mm	in.	mm	in.	mm	in.	mm	in.	mm	lb	kg
03-07	77.9	1978	36-54	914-1371	44.8	1139	42.0	1067	23.5	597	1125	510

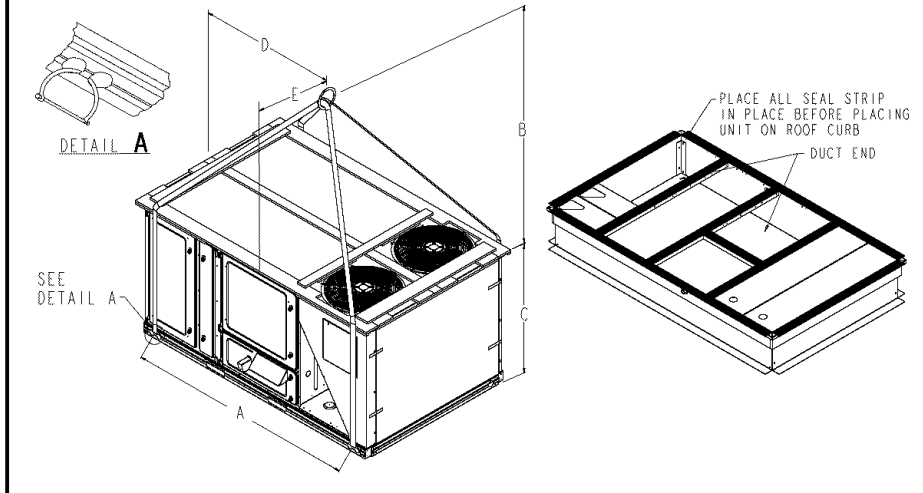

Fig. 2 — 48PG Rigging Label

Step 4 — Field Fabricate Ductwork — On vertical units, secure all ducts to roof curb and building structure. *Do not connect ductwork to unit.* For horizontal applications, field-supplied flanges should be attached to horizontal discharge openings and all ductwork secured to the flanges. Insulate and weatherproof all external ductwork, joints, and roof openings with counter flashing and mastic in accordance with applicable codes.

Ducts passing through an unconditioned space must be insulated and covered with a vapor barrier.

If a plenum return is used on a vertical unit, the return should be ducted through the roof deck to comply with applicable fire codes.

A minimum clearance is not required around ductwork. Cabinet return-air static pressure (a negative condition) shall not exceed 0.35 in. wg with economizer or 0.45 in. wg without economizer.

These units are designed for a minimum continuous return-air temperature in heating of 50 F (dry bulb), or an intermittent operation down to 45 F (dry bulb), such as when used with a night set-back thermostat.

To operate at lower return-air temperatures, a field-supplied outdoor-air temperature control must be used to initiate both stages of heat when the temperature is below 45 F. Indoor comfort may be compromised when these lower air temperatures are used with insufficient heating temperature rise.

Step 5 — Make Unit Duct Connections

VERTICAL SUPPLY/RETURN CONFIGURATION — Unit is shipped in vertical supply/return configuration. Ductwork openings are shown in Fig. 1 and 3. Attach the ductwork to the roof curb. Do not attach duct directly to the unit.

⚠ WARNING

For vertical supply and return units, tools or parts could drop into ductwork and cause an injury. Install a 90-degree turn in the return ductwork between the unit and the conditioned space. If a 90-degree elbow cannot be installed, then a grille of sufficient strength and density should be installed to prevent objects from falling into the conditioned space.

HORIZONTAL SUPPLY/RETURN APPLICATIONS — Unit can be field-converted from vertical supply/return to horizontal supply/return. Remove all screws securing horizontal duct covers to duct panel. Save panels. Install duct covers in the vertical duct openings in the basepan with the insulation side up. Covers will drop into openings and can be secured using field-supplied self-tapping screws. Ductwork can be attached to duct flanges provided on unit. When securing ductwork to unit, do not drill in area below bead or above top edge of duct opening.

Table 1 — Physical Data

BASE UNIT 48PG	03	04	05	06	07	
NOMINAL CAPACITY (Tons)	2	3	4	5	6	
OPERATING WEIGHT (lb)						
Unit*	774	786	901	921	961	
Economizer						
Vertical	40	40	40	40	40	
Horizontal	50	50	50	50	50	
Roof Curb						
14-in.	122	122	122	122	122	
24-in.	184	184	184	184	184	
COMPRESSOR			Fully Hermetic Scroll			
Quantity	1	1	1	1	1	
Oil Type			Copeland 3MA			
Number of Refrigerant Circuits	1	1	1	1	1	
Oil (oz)	38	42	42	66	56	
REFRIGERANT TYPE			R-410A (Puron® Refrigerant)			
Expansion Device	TXV	TXV	TXV	TXV	TXV	
Operating Charge (lb)	7.3	9.0	15.7	16.6	19.0	
CONDENSER COIL			Enhanced Copper Tubes, Aluminum Lanced Fins			
Condenser A (Outer)						
Rows...Fins/in.	1...17	1...17	2...17	2...17	2...17	
Face Area (sq ft)	12.6	12.6	12.6	12.6	12.6	
Condenser B (Inner)						
Rows...Fins/in.	—	1...17	2...17	2...17	2...17	
Face Area (sq ft)	—	12.6	12.6	12.6	12.6	
CONDENSER FAN			Propeller			
Quantity...Diameter (in.)	1...24	1...24	1...24	1...24	1...24	
Nominal Cfm (Total, all fans)	3500	3500	3500	4500	4500	
Motor Hp	1/8	1/8	1/8	1/4	1/4	
Nominal Rpm — High Speed	825	825	825	1100	1100	
Nominal Rpm — Low Speed	300	300	300	300	300	
EVAPORATOR COIL			Enhanced Copper Tubes, Aluminum Double-Wavy Fins, Face Split			
Rows...Fins/in.	2...15	2...15	2...15	3...15	4...15	
Face Area (sq ft)	9.3	9.3	9.3	9.3	9.3	
EVAPORATOR FAN			Centrifugal Type, Belt Drive			
Quantity...Size (in.)	1...12 x 9	1...12 x 9	1...12 x 9	1...12 x 9	1...12 x 9	
Type Drive	Low High	Low High	Low High	Low High	Low High	
Type	Belt	Belt	Belt	Belt	Belt	
High	Belt	Belt	Belt	Belt	Belt	
Nominal Cfm	800	1200	1600	2000	2400	
Maximum Continuous Bhp	Low High	Low High	Low High	Low High	Low High	
Low	0.85	0.85	0.85	0.85/2.40†	2.40	
High	0.85	0.85	1.60/2.40†	3.10	3.10	
Motor Nominal Rpm	1620	1620	1620	1725	1725	
Motor Frame Size	Low High	Low High	Low High	Low High	Low High	
Low	48Y	48Y	48Y	56Y	56Y	
High	48Y	48Y	56Y	56Y	56Y	
Fan Rpm Range	Low High	Low High	Low High	Low High	Low High	
Low	482-736	482-736	596-910	690-978	796-1128	
High	656-1001	796-1128	828-1173	929-1261	1150-1438	
Motor Bearing Type	Ball	Ball	Ball	Ball	Ball	
Maximum Fan Rpm	2000	2000	2000	2000	2000	
Motor Pulley Pitch Diameter Range (in.)	Low High	Low High	Low High	Low High	Low High	
Low	1.9-2.9	1.9-2.9	1.9-2.9	2.4-3.4	2.4-3.4	
High	1.9-2.9	2.4-3.4	2.4-3.4	2.8-3.8	4.0-5.0	
Fan Pulley Pitch Diameter (in.)	Low High	Low High	Low High	Low High	Low High	
Low	6.8	6.8	5.5	6.0	5.2	
High	5.0	5.2	5.0	5.2	6.0	
Nominal Motor Shaft Diameter (in.)	Low High	Low High	Low High	Low High	Low High	
Low	1/2	1/2	1/2	5/8	5/8	
High	1/2	1/2	5/8	5/8	7/8	
Belt...Pitch Length (in.)	Low High	Low High	Low High	Low High	Low High	
Low	49.3	49.3	49.3	49.3	49.3	
High	49.3	49.3	49.3	49.3	52.3	
Belt...Type	Low High	Low High	Low High	Low High	Low High	
Low	AX	AX	AX	AX	AX	
High	AX	AX	AX	AX	AX	
Pulley Center Line Distance Min. (in.)	Low High	Low High	Low High	Low High	Low High	
Low	16.2	16.2	16.2	16.2	16.2	
High	16.2	16.2	16.2	16.2	16.2	
Pulley Center Line Distance Max. (in.)	Low High	Low High	Low High	Low High	Low High	
Low	20.2	20.2	20.2	20.2	20.2	
High	20.2	20.2	20.2	20.2	20.2	
Speed Change per Full Turn of Movable Pulley Flange (rpm)	Low High	Low High	Low High	Low High	Low High	
Low	48	48	59	58	66	
High	65	62	69	66	58	
Movable Pulley Maximum Full Turns from Closed Position	Low High	Low High	Low High	Low High	Low High	
Low	5	5	5	5	5	
High	5	5	5	5	5	
Factory Pulley Setting (rpm)	Low High	Low High	Low High	Low High	Low High	
Low	736	736	910	978	1128	
High	794	929	1035	1128	1323	
Fan Shaft Diameter at Pulley (in.)	3/4	3/4	3/4	3/4	3/4	
GAS HEAT SECTION						
Rollout Switch						
Open Temperature (F)	Low Med High	195 195 225	195 195 225	195 225 195	195 225 195	
Closed Temperature (F)	Low Med High	N/A N/A 115	115 115 175	115 175 115	115 175 115	
Standard Units						
Gas Input (Btuh)	Stage 1/Stage 2	PGD/L PGE/M	— —	39,200/ 56,000 52,500/ 75,000	39,200/ 56,000 52,500/ 75,000	52,500/ 75,000 79,100/113,000
Low NOx Units	PGF/N PGD/L PGE/M PGF/N	56,000 — 75,000 56,000	79,100/113,000 — 75,000 113,000	79,100/113,000 56,000 75,000 113,000	105,700/151,000 75,000 113,000 151,000	
Burner Orifice Diameter (in. ...drill size)**						
Natural Gas	0.0820...45	0.0820...45	0.0820...45	0.0820...45	0.0820...45	
Liquid Propane	0.0650...52	0.0650...52	0.0650...52	0.065...52	0.065...52	
Thermostat Heat Anticipator Setting (amps)						
First Stage	0.3	0.3	0.3	0.3	0.3	
Second Stage	0.4	0.4	0.4	0.4	0.4	
Manifold Pressure (in. wg)						
Natural Gas	3.5	3.5	3.5	3.5	3.5	
Liquid Propane	3.5	3.5	3.5	3.5	3.5	
Gas Valve Quantity	1	1	1	1	1	
Gas Supply Pressure Range (in. wg)	5.0-13.0	5.0-13.0	5.0-13.0	5.0-13.0	5.0-13.0	
Field Gas Connection Size (in.)	1/2	1/2	1/2	1/2	1/2	
HIGH-PRESSURE SWITCH (psig)						
Cutout	660 ± 10	660 ± 10	660 ± 10	660 ± 10	660 ± 10	
Reset (Auto.)	505 ± 20	505 ± 20	505 ± 20	505 ± 20	505 ± 20	
LOW-PRESSURE SWITCH (psig)						
Cutout	40 ± 7	40 ± 7	40 ± 7	40 ± 7	40 ± 7	
Reset (Auto.)	80 ± 7	80 ± 7	80 ± 7	80 ± 7	80 ± 7	
FREEZE PROTECTION THERMOSTAT (F)						
Cutout	30 ± 5	30 ± 5	30 ± 5	30 ± 5	30 ± 5	
Reset (Auto.)	45 ± 5	45 ± 5	45 ± 5	45 ± 5	45 ± 5	
RETURN-AIR FILTERS			Throwaway Type			
Quantity...Size (in.)	4...16 x 20 x 2	4...16 x 20 x 2	4...16 x 20 x 2	4...16 x 20 x 2	4...16 x 20 x 2	

LEGEND

TXV — Thermostatic Expansion Valve

*Aluminum evaporator coil/aluminum condenser coil.

†Single phase/three phase.

**For applications less than 2000 ft elevation.

NOTES:

- Do not locate adjacent units with flue discharge facing economizer inlet.
Minimum clearances to be:
 - Front 48 in. to combustible surfaces (18 in. to combustible surfaces when using accessory flue discharge deflector). When not using roof curb (1 in.) bottom of base pan to combustible surfaces. When not using roof curb (0 in.) bottom of base rail to combustible surfaces.
 - Right side, front and back sides (36 in.) for proper condenser airflow.
 - Overhead (60 in.) to assure proper condenser airflow between unit and control box (42 in. per NEC [National Electrical Code]).
 - Between units and ungrounded surface control box side (36 in. per NEC).
 - Between unit and block or concrete wall and other grounded surfaces control box side 42 in.).
 - Horizontal supply and return. (0 in.).
- Downshot ducts designed to be attached to accessory roof curb only. If unit is mounted side supply, it is recommended the ducts must be supported by cross braces as done on accessory roof curb.
- With the exception of clearance for the condenser coil, combustible surfaces, and the damper/power exhaust as stated in Note 1, a removable fence or barricade requires no clearance.
- Dimensions are from outside of base rail. Allow 0-5/16 [8] on each side for top cover drip edge.
- Units may be installed on combustible floors made from Class A, B, C roof covering material if set on base rails.

UNIT 48PG	STD UNIT WEIGHT		(A) CORNER WEIGHT		(B) CORNER WEIGHT		(C) CORNER WEIGHT		(D) CORNER WEIGHT	
	lb	kg	lb	kg	lb	kg	lb	kg	lb	kg
03	774	351	170.1	77.1	142.3	64.5	210.3	95.4	251.3	114.0
04	786	357	172.7	78.3	144.5	65.5	213.5	96.8	255.2	115.8
05	901	409	198.0	89.8	165.7	75.2	244.8	111.0	292.5	132.7
06	921	418	202.4	91.8	169.4	76.8	250.2	113.5	299.0	135.6
07	961	436	211.2	95.8	176.7	80.2	261.1	118.4	312.0	141.5

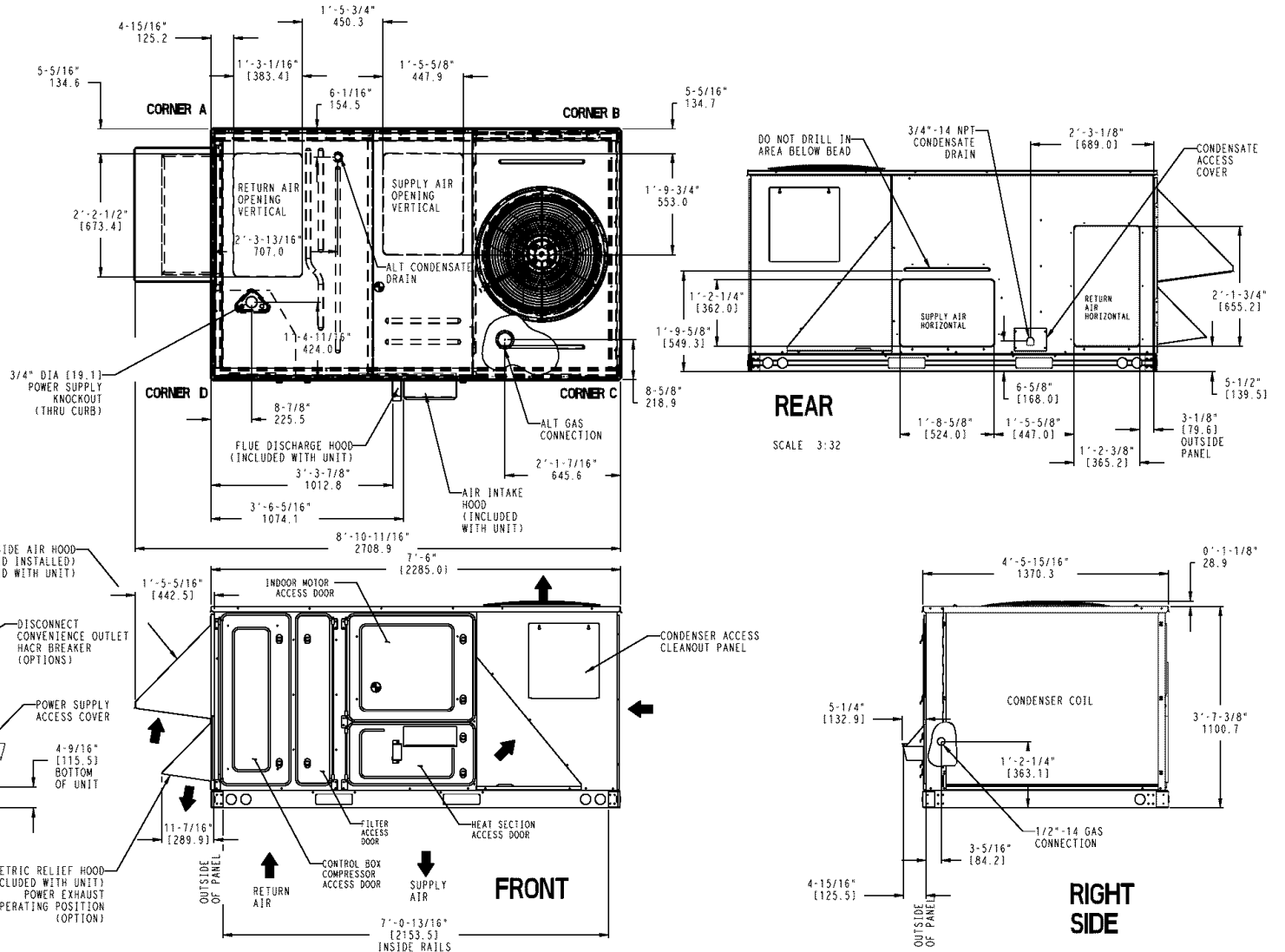
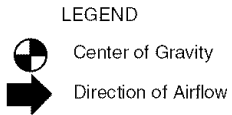

Fig. 3 — Base Unit Dimensions

Step 6 — Install Flue Hood and Inlet Hood —

Flue hood (smaller hood), inlet hood (larger hood), and screens are shipped inside the unit in the gas section. To install, open the heat section door. The flue hood is attached to the heat section panel from the outside using the screws provided. See Fig. 4 and 5.

The inlet hood is installed by inserting the hood through the back of the heat panel. Attach the hood by inserting the screws provided through the clearance holes in the heat panel and into the intake hood.

NOTE: When properly installed, the flue hood will line up with the combustion fan housing. See Fig. 6.

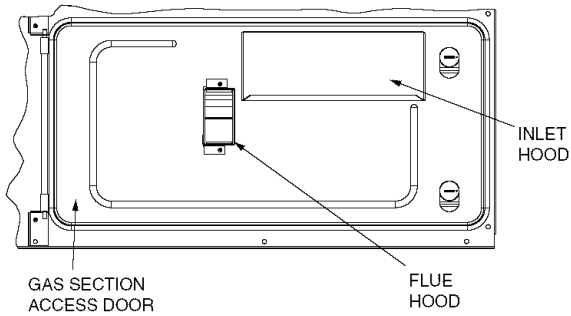

Fig. 4 — Flue and Inlet Hood Locations

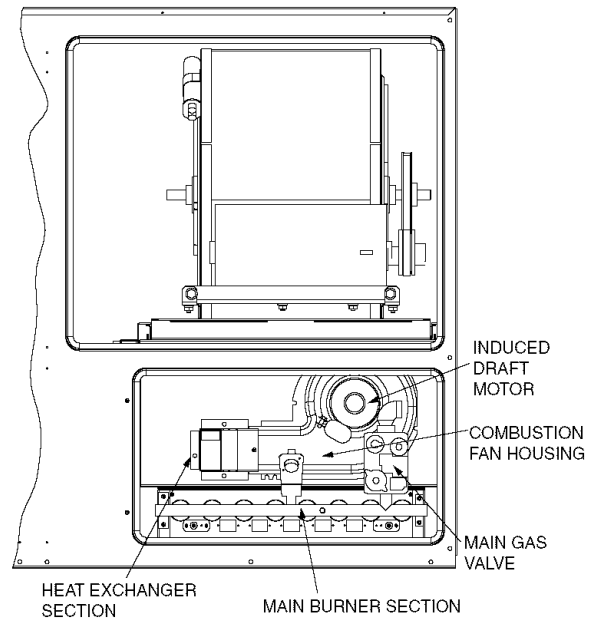

Fig. 6 — Typical Gas Heating Section

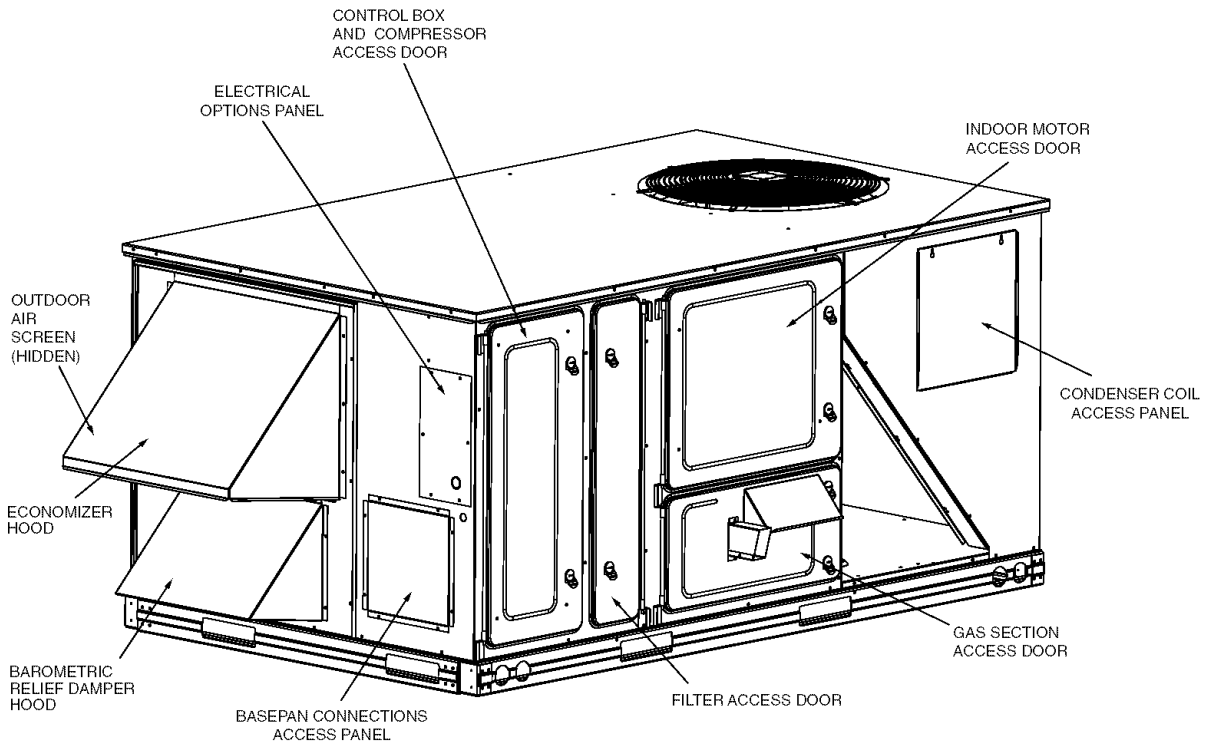

Fig. 5 — Panel and Filter Locations

Step 7 — Install External Trap for Condensate Drain

Drain — The unit's 3/4-in. condensate drain connections are located on the bottom and side of the unit. Unit discharge connections do not determine the use of drain connections; either drain connection can be used with vertical or horizontal applications. See Fig. 3 for locations.

When using the standard side drain connection, make sure the plug (red) in the alternate bottom connection is tight before installing the unit. See Fig. 7.

To use the bottom drain connection for a roof curb installation, relocate the factory-installed plug (red) from the bottom connection to the side connection. A 1/2-in. socket extension can be used to remove the plug. See Fig. 7. The piping for the condensate drain and external trap can be completed after the unit is in place.

All units must have an external trap for condensate drainage. Install a trap at least 4-in. deep and protect against freeze-up. If drain line is installed downstream from the external trap, pitch the line away from the unit at 1-in. per 10 ft of run. Do not use a pipe size smaller than the unit connection (3/4-in.). See Fig. 8 and 9.

The 48PG units are provided with a removable condensate pan for ease of cleaning. Refer to Cleaning section on page 37 for more information. It is recommended that a union be placed between the unit and condensate drainage to ease the removal of the pan during servicing. Adequate clearance should be

allowed if removal of condensate pan is required. Allow 54-in. between condensate pan access panel and any obstruction for complete removal.

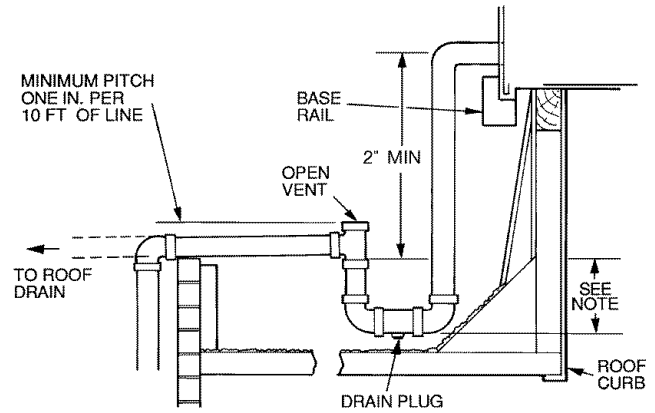

NOTE: Trap should be deep enough to offset maximum unit static difference. A 4-in. trap is recommended.

Fig. 9 — Condensate Drain Piping Details

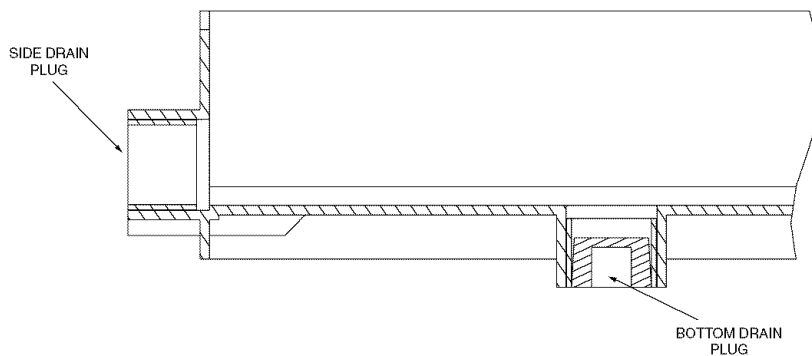

Fig. 7 — Condensate Drain Pan

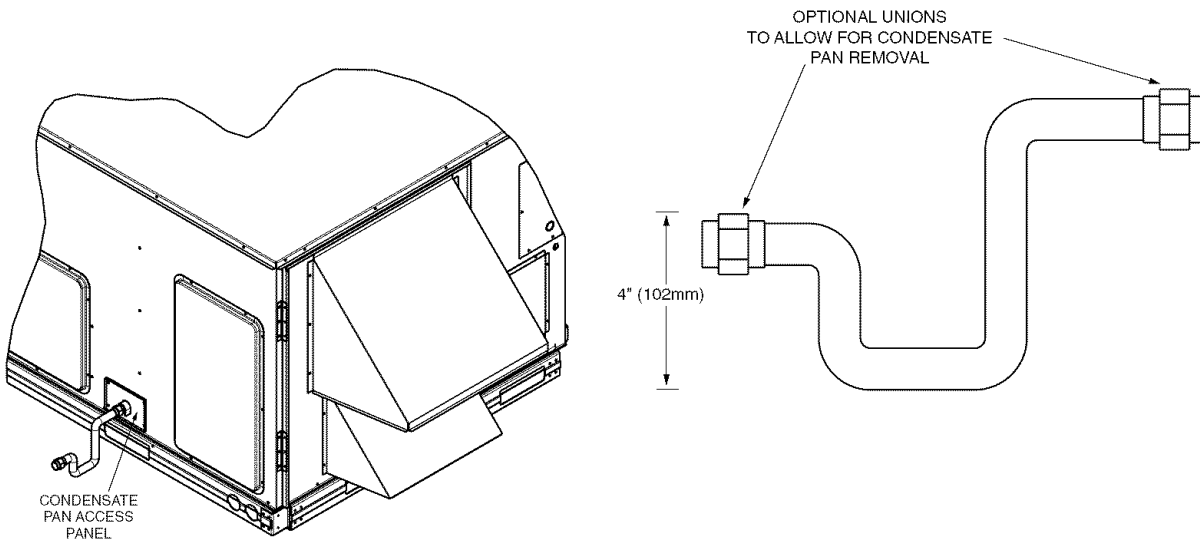

Fig. 8 — External Trap for Condensate Drain

Step 8 — Install Gas Piping — Unit is equipped for use with natural gas. Refer to local building codes, or in the absence of local codes, to ANSI Z223.1-latest year and addendum Z223.1A-latest year entitled HFGC. In Canada, installation must be in accordance with the CAN1.B149.1 and CAN1.B149.2 installation codes for gas burning appliances.

Support gas piping as shown in the table in Fig. 10. For example, a 3/4-in. gas piping must have one field-fabricated support beam every 8 ft. Therefore, an 18-ft long gas pipe would have a minimum of 3 support beams. See Fig. 10 for typical pipe guide and locations of external manual gas shutoff valve.

Install field-supplied manual gas shutoff valve with a 1/8-in. NPT pressure tap for test gage connection at unit. The pressure tap is located on the gas manifold, adjacent to the gas valve. Field gas piping must include sediment trap and union. See Fig. 11. Install a field-supplied gas regulator.

▲ WARNING

Do not pressure test gas supply while connected to unit. Always disconnect union before servicing. Damage to equipment or personal injury may result.

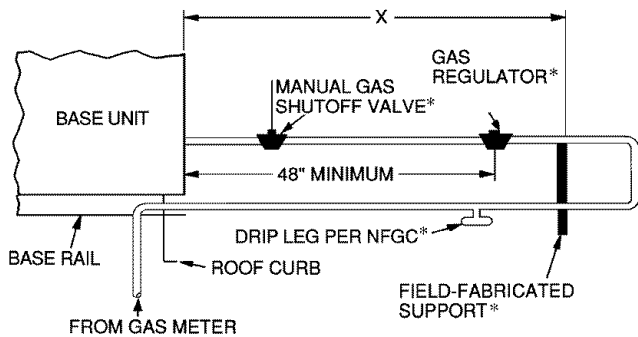

LEGEND

NFGC — National Fuel Gas Code

*Field supplied.

NOTE: Follow all local codes.

STEEL PIPE NOMINAL DIAMETER (in.)	SPACING OF SUPPORTS X DIMENSION (ft)
1/2	6
3/4 or 1	8
1 1/4 or larger	10

Fig. 10 — Gas Piping Guide (With Accessory Thru-the-Curb Service Connections)

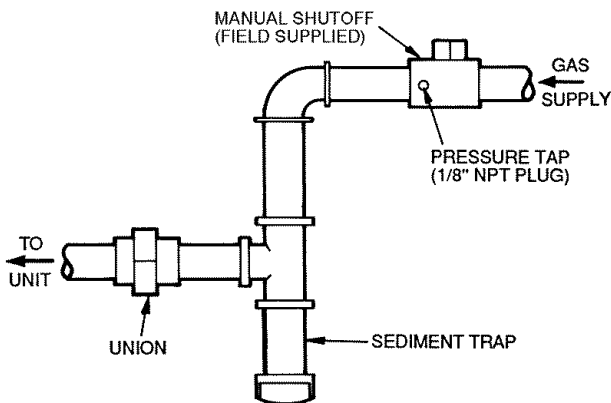

Fig. 11 — Field Gas Piping

IMPORTANT: Natural gas pressure at unit gas connection must not be less than 5.0 in. wg or greater than 13.0 in. wg for all heat sizes.

Size gas-supply piping for 0.5-in. wg maximum pressure drop. Do not use supply pipe smaller than unit gas connection.

Step 9 — Make Electrical Connections

FIELD POWER SUPPLY — All 208/230-v units are factory wired for 230-v power supply. If the 208/230-v unit is to be connected to a 208-v power supply, the transformer must be re-wired by moving the black wire with the 1/4-in. female quick connector from the 230-volt connection and moving to the 200-volt 1/4-in. male terminal on the primary side of the transformer.

Refer to unit label diagram for additional information. All field wiring must comply with NEC (National Electrical Code) and local codes. Size wire based on MCA (Minimum Circuit Amps) on the unit informative plate. Leads are provided for field wire connections. Use UL (Underwriters' Laboratories) approved copper/aluminum connector.

When installing units, provide safety disconnect per NEC Article 440 or local codes. For non-fused disconnects, size the disconnect according to the sizing data provided in the electrical data tables. If a fused disconnect is used, determine the minimum size for the switch based on the disconnect sizing data provided in the electrical data tables and then coordinate the disconnect housing size to accommodate the Maximum Over-current Protection (MOCP) device size as marked on the unit informative plate. See Tables 2A and 2B.

See Fig. 12 for power wiring connection to unit leads and equipment ground.

Route power and ground lines through control box end panel or unit basepan (see Fig. 3) to connections as shown on unit wiring diagram and Fig. 12. Factory leads may be wired directly to the disconnect.

▲ CAUTION

The correct power phasing is critical to the operation of the scroll compressors. An incorrect phasing will result in compressor shutdown on thermal overload and possible damage to compressor. Should this occur, power phase correction must be made to the incoming power.

▲ WARNING

Unit cabinet must have an uninterrupted, unbroken electrical ground to minimize the possibility of personal injury if an electrical fault should occur. This ground may consist of electrical wire connected to unit ground lug in control compartment, or conduit approved for electrical ground when installed in accordance with NEC; ANSI/NFPA (National Fire Protection Association), latest edition, and local electrical codes. *Do not use gas piping as an electrical ground.* Failure to follow this warning could result in the installer being liable for personal injury of others.

Field wiring must conform to temperature limitations for type "T" wire. All field wiring must comply with NEC and local requirements.

Operating voltage to compressor must be within voltage range indicated on unit nameplate. On 3-phase units, voltages between phases must be balanced within 2%.

Unit failure as a result of operation on improper line voltage or excessive phase imbalance constitutes abuse and may cause damage to electrical components.

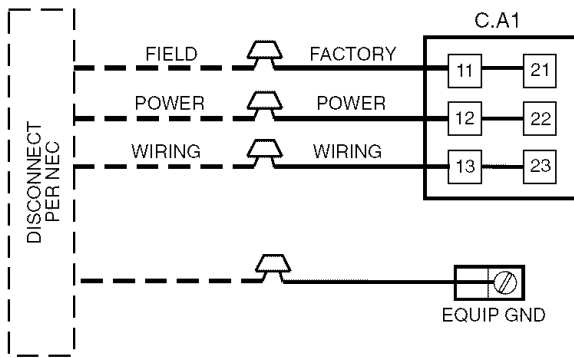

LEGEND

- C.A1** — Compressor Contactor (A1)
- EQUIP** — Equipment
- GND** — Ground
- NEC** — National Electrical Code

NOTE: The maximum wire size for C.A1 is 2/0.

Fig. 12 — Field Power Wiring Connections

FIELD CONTROL WIRING — Unit can be controlled with a Carrier-approved accessory thermostat. Install thermostat according to the installation instructions included with accessory. Locate thermostat assembly on a solid interior wall in the conditioned space to sense average temperature.

Route thermostat cable or equivalent single leads of colored wire from subbase terminals through conduit into unit to low-voltage connections as shown on unit label wiring diagram and in Fig. 13.

NOTE: For wire runs up to 50 ft, use no. 18 AWG (American Wire Gage) insulated wire (35 C minimum). For 50 to 75 ft, use no. 16 AWG insulated wire (35 C minimum). For over 75 ft, use no. 14 AWG insulated wire (35 C minimum). All wire larger than no. 18 AWG cannot be directly connected at the thermostat and will require a junction box and splice at the thermostat.

Set heat anticipator settings as follows:

VOLTAGE	STAGE 1 (W1) ON	STAGE 1 AND 2 (W1 AND W2) ON
All	0.3	0.4

Settings may be changed slightly to provide a greater degree of comfort for a particular installation.

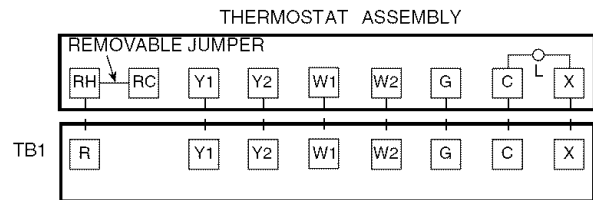

Fig. 13 — Field Control Thermostat Wiring

Table 2A — Electrical Data — Units Without Optional Convenience Outlet

UNIT 48PG	NOMINAL POWER SUPPLY Volts-Ph-Hz	VOLTAGE RANGE		COMPRESSOR		OFM		PWR EXH FLA (ea)	IFM TYPE	IFM FLA	COMBUSTION FAN MOTOR FLA	POWER SUPPLY		DISCONNECT SIZE	
		Min	Max	RLA	LRA	Qty	FLA (ea)					MCA	MOCP	FLA	LRA
03	208/230-1-60	187	253	12.8	60	1	1.0	---	STD	4.9	0.52	21.9/21.9	25/25	22/22	74/74
												21.9/21.9	25/25	22/22	74/74
												23.3/23.3	25/25	23/23	76/76
												23.3/23.3	25/25	23/23	76/76
												25.2/25.2	30/30	24/24	97/97
												25.2/25.2	30/30	24/24	97/97
04	208/230-1-60	187	253	15.4	83	1	1.0	---	STD	4.9	0.52	25.2/25.2	30/30	24/24	97/97
												25.2/25.2	30/30	24/24	97/97
												26.6/26.6	30/30	26/26	99/99
												26.6/26.6	30/30	26/26	99/99
												20.3/20.3	25/25	20/20	91/91
												20.3/20.3	25/25	20/20	91/91
	208/230-3-60	187	253	11.5	77	1	1.0	---	STD	4.9	0.52	21.7/21.7	25/25	22/22	93/93
												21.7/21.7	25/25	22/22	93/93
												21.7/21.7	25/25	22/22	93/93
												21.7/21.7	25/25	22/22	93/93
												21.7/21.7	25/25	22/22	93/93
												21.7/21.7	25/25	22/22	93/93
	460-3-60	414	506	5.1	35	1	0.5	---	STD	2.1	0.30	9	15	9	42
												9	15	9	42
												9.6	15	10	43
												9.6	15	10	43
												9.6	15	10	43
												9.6	15	10	43
	575-3-60	518	633	4.3	31	1	0.5	---	STD	2.1	0.24	8	15	8	37
												8	15	8	37
												9.4	15	10	39
												9.4	15	10	39
												9.4	15	10	39
												9.4	15	10	39
05	208/230-1-60	187	253	20.5	109	1	1.0	---	STD	4.9	0.52	31.5/31.5	35/35	30/30	123/123
												31.5/31.5	35/35	30/30	123/123
												33.6/33.6	35/35	33/33	148/148
												32.9/32.9	35/35	32/32	125/125
												32.9/32.9	35/35	32/32	125/125
												35.0/35.5	40/40	34/34	150/150
	208/230-3-60	187	253	14.6	91	1	1.0	---	STD	4.9	0.52	24.2/24.2	25/25	24/24	105/105
												24.2/24.2	25/25	24/24	105/105
												24.5/24.5	25/25	24/24	123/123
												24.5/24.5	25/25	24/24	123/123
												25.6/25.6	30/30	25/25	107/107
												25.6/25.6	30/30	25/25	107/107
	460-3-60	414	506	7.1	46	1	0.5	---	STD	2.1	0.30	11.5	15	11	53
												11.5	15	11	53
												12	15	12	62
												12	15	12	62
												12.1	15	12	54
												12.1	15	12	54
	575-3-60	518	633	5.1	34	1	0.5	---	STD	2.1	0.24	9	15	9	40
												9	15	9	40
												8.9	15	9	46
												8.9	15	9	46
												10.4	15	10	42
												10.4	15	10	42
06	208/230-1-60	187	253	26.9	145	1	1.5	---	STD	4.9	0.52	40.0/40.0	45/45	38/38	160/160
												40.0/40.0	45/45	38/38	160/160
												42.1/42.1	45/45	41/41	185/185
												41.4/41.4	45/45	40/40	162/162
												41.4/41.4	45/45	40/40	162/162
												43.5/43.5	50/50	42/42	187/187
	208/230-3-60	187	253	17.6	123	1	1.5	---	STD	5.2	0.52	28.7/28.7	30/30	28/28	156/156
												28.7/28.7	30/30	28/28	156/156
												28.7/28.7	30/30	28/28	156/156
												28.7/28.7	30/30	28/28	156/156
												30.1/30.1	35/35	30/30	158/158
												30.1/30.1	35/35	30/30	158/158
	460-3-60	414	506	7.7	50	1	0.8	---	STD	2.6	0.30	13	15	13	67
												13	15	13	67
												13.6	15	13	68
												13.6	15	13	68
												13.6	15	13	68
												13.6	15	13	68
	575-3-60	518	633	6.1	40	1	0.8	---	STD	2.0	0.24	10.4	15	10	53
												10.4	15	10	53
												10.4	15	10	53
												10.4	15	10	53
												11.8	15	12	55
												11.8	15	12	55
07	208/230-3-60	187	253	20.5	149	1	1.5	---	STD	5.2	0.52	32.3/32.3	35/35	31/31	182/182
												32.3/32.3	35/35	31/31	182/182
												34.6/34.6	35/35	34/34	208/208
												34.6/34.6	35/35	34/34	208/208
												33.7/33.7	35/35	33/33	184/184
												33.7/33.7	35/35	33/33	184/184
	460-3-60	414	506	9.6	75	1	0.8	---	STD	2.6	0.30	15.4	20	15	92
												15.4	20	15	92
												16.2	20	16	105
												16.2	20	16	105
												16	20	16	93
												16.8	20	17	106
575-3-60	518	633	7.6	54	1	0.8	---	STD	2.0	0.24	12.3	15	12	67	
											12.3	15	12	67	
											13.1	15	13	78	
											13.1	15	13	78	
											13.7	15	14	69	
											13.7	15	14	69	

LEGEND

- FLA — Full Load Amps
- HACR — Heating, Air Conditioning and Refrigeration
- IFM — Indoor (Evaporator) Fan Motor
- LRA — Locked Rotor Amps
- MCA — Minimum Circuit Amps
- MOCP — Maximum Overcurrent Protection
- NEC — National Electrical Code
- OFM — Outdoor (Condenser) Fan Motor
- RLA — Rated Load Amps



Example: Supply voltage is 230-3-60.

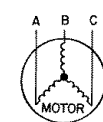

AB = 224 v
BC = 231 v
AC = 226 v

$$\text{Average Voltage} = \frac{224 + 231 + 226}{3}$$

$$= \frac{681}{3}$$

$$= 227$$

NOTES:

1. In compliance with NEC requirements for multimotor and combination load equipment (refer to NEC Articles 430 and 440), the overcurrent protective device for the unit shall be fuse or HACR breaker. Canadian units may be fuse or circuit breaker.

2. Unbalanced 3-Phase Supply Voltage

Never operate a motor where a phase imbalance in supply voltage is greater than 2%.

Use the following formula to determine the percent of voltage imbalance.

% Voltage Imbalance

$$= 100 \times \frac{\text{max voltage deviation from average voltage}}{\text{average voltage}}$$

Determine maximum deviation from average voltage.

- (AB) 227 - 224 = 3 v
- (BC) 231 - 227 = 4 v
- (AC) 227 - 226 = 1 v

Maximum deviation is 4 v.

Determine percent of voltage imbalance.

$$\% \text{ Voltage Imbalance} = 100 \times \frac{4}{227}$$

$$= 1.76\%$$

This amount of phase imbalance is satisfactory as it is below the maximum allowable 2%.

IMPORTANT: If the supply voltage phase imbalance is more than 2%, contact the local electric utility company immediately.

Table 2B — Electrical Data — Units With Optional Convenience Outlet

UNIT 48PG	NOMINAL POWER SUPPLY Volts-Ph-Hz	VOLTAGE RANGE		COMPRESSOR		OFM		PWR EXH FLA (ea)	IFM TYPE	IFM FLA	COMBUSTION FAN MOTOR FLA	POWER SUPPLY		DISCONNECT SIZE	
		Min	Max	RLA	LRA	Qty	FLA (ea)					MCA	MOCP	FLA	LRA
03	208/230-1-60	187	253	12.8	60	1	1.0	—	STD	4.9	0.52	26.7/26.7	30/30	27/27	79/79
									ALT	4.9		26.7/26.7	30/30	27/27	79/79
									STD	4.9		28.1/28.1	30/30	29/29	81/81
									ALT	4.9		28.1/28.1	30/30	29/29	81/81
04	208/230-1-60	187	253	15.4	83	1	1.0	—	STD	4.9	0.52	30.0/30.0	30/30	30/30	102/102
									ALT	4.9		30.0/30.0	30/30	30/30	102/102
									STD	4.9		31.4/31.4	35/35	32/32	104/104
									ALT	4.9		31.4/31.4	35/35	32/32	104/104
	208/230-3-60	187	253	11.5	77	1	1.0	—	STD	4.9	0.52	25.1/25.1	30/30	26/26	96/96
									ALT	4.9		25.1/25.1	30/30	26/26	96/96
									STD	4.9		26.5/26.5	30/30	27/27	98/98
									ALT	4.9		26.5/26.5	30/30	27/27	98/98
	460-3-60	414	506	5.1	35	1	0.5	—	STD	2.1	0.30	11.2	15	11	44
									ALT	2.1		11.2	15	11	44
									STD	2.1		11.8	15	12	45
									ALT	2.1		11.8	15	12	45
	575-3-60	518	633	4.3	31	1	0.5	—	STD	2.1	0.24	9.7	15	10	39
									ALT	2.1		9.7	15	10	39
									STD	2.1		11.1	15	12	41
									ALT	2.1		11.1	15	12	41
05	208/230-1-60	187	253	20.5	109	1	1.0	—	STD	4.9	0.52	36.3/36.3	40/40	36/36	128/128
									ALT	7.0		38.4/38.4	40/40	38/38	153/153
									STD	4.9		37.7/37.7	40/40	37/37	130/130
									ALT	7.0		39.8/39.8	40/40	40/40	155/155
	208/230-3-60	187	253	14.6	91	1	1.0	—	STD	4.9	0.52	29.0/29.0	30/30	29/29	110/110
									ALT	5.2		29.3/29.3	30/30	29/29	128/128
									STD	4.9		30.4/30.4	35/35	31/31	112/112
									ALT	5.2		30.7/30.7	35/35	31/31	130/130
	460-3-60	414	506	7.1	46	1	0.5	—	STD	2.1	0.30	13.7	15	14	55
									ALT	2.6		14.2	15	14	64
									STD	2.1		14.3	15	14	56
									ALT	2.6		14.8	15	15	65
	575-3-60	518	633	5.1	34	1	0.5	—	STD	2.1	0.24	10.7	15	11	42
									ALT	2.0		10.6	15	11	48
									STD	2.1		12.1	15	12	44
									ALT	2.0		12	15	12	50
06	208/230-1-60	187	253	26.9	145	1	1.5	—	STD	4.9	0.52	44.8/44.8	50/50	44/44	165/165
									ALT	7.0		46.9/46.9	50/50	46/46	190/190
									STD	4.9		46.2/46.2	50/50	45/45	167/167
									ALT	7.0		48.3/48.3	50/50	48/48	192/192
	208/230-3-60	187	253	17.6	123	1	1.5	—	STD	5.2	0.52	33.5/33.5	35/35	33/33	161/161
									ALT	5.2		33.5/33.5	35/35	33/33	161/161
									STD	5.2		34.9/34.9	35/35	35/35	163/163
									ALT	5.2		34.9/34.9	35/35	35/35	163/163
	460-3-60	414	506	7.7	50	1	0.8	—	STD	2.6	0.30	15.2	20	15	69
									ALT	2.6		15.2	20	15	69
									STD	2.6		15.8	20	16	70
									ALT	2.6		15.8	20	16	70
	575-3-60	518	633	6.1	40	1	0.8	—	STD	2.0	0.24	12.1	15	12	55
									ALT	2.0		12.1	15	12	55
									STD	2.0		13.5	15	14	57
									ALT	2.0		13.5	15	14	57
07	208/230-3-60	187	253	20.5	149	1	1.5	—	STD	5.2	0.52	37.1/37.1	40/40	37/37	187/187
									ALT	7.5		39.4/39.4	40/40	39/39	213/213
									STD	5.2		38.5/38.5	40/40	38/38	189/189
									ALT	7.5		40.8/40.8	45/45	41/41	215/215
	460-3-60	414	506	9.6	75	1	0.8	—	STD	2.6	0.30	17.6	20	17	94
									ALT	3.4		18.4	20	18	107
									STD	2.6		18.2	20	18	95
									ALT	3.4		19	20	19	108
575-3-60	518	633	7.6	54	1	0.8	—	STD	2.0	0.24	14	15	14	69	
								ALT	2.8		14.8	15	15	80	
								STD	2.0		15.4	20	16	71	
								ALT	2.8		16.2	20	16	82	

LEGEND

- FLA — Full Load Amps
- HACR — Heating, Air Conditioning and Refrigeration
- IFM — Indoor (Evaporator) Fan Motor
- LRA — Locked Rotor Amps
- MCA — Minimum Circuit Amps
- MOCP — Maximum Overcurrent Protection
- NEC — National Electrical Code
- OFM — Outdoor (Condenser) Fan Motor
- RLA — Rated Load Amps



Example: Supply voltage is 230-3-60.

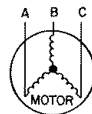

AB = 224 v
BC = 231 v
AC = 226 v

$$\text{Average Voltage} = \frac{224 + 231 + 226}{3}$$

$$= \frac{681}{3}$$

$$= 227$$

NOTES:

1. In compliance with NEC requirements for multimotor and combination load equipment (refer to NEC Articles 430 and 440), the overcurrent protective device for the unit shall be fuse or HACR breaker. Canadian units may be fuse or circuit breaker.

2. Unbalanced 3-Phase Supply Voltage

Never operate a motor where a phase imbalance in supply voltage is greater than 2%.

Use the following formula to determine the percent of voltage imbalance.

% Voltage Imbalance

$$= 100 \times \frac{\text{max voltage deviation from average voltage}}{\text{average voltage}}$$

Determine maximum deviation from average voltage.

- (A) 227 - 224 = 3 v
- (B) 231 - 227 = 4 v
- (C) 227 - 226 = 1 v

Maximum deviation is 4 v.

Determine percent of voltage imbalance.

$$\% \text{ Voltage Imbalance} = 100 \times \frac{4}{227}$$

$$= 1.76\%$$

This amount of phase imbalance is satisfactory as it is below the maximum allowable 2%.

IMPORTANT: If the supply voltage phase imbalance is more than 2%, contact the local electric utility company immediately.

Step 10 — Optional EconoMiSer IV — The optional EconoMiSer IV comes from the factory fully wired. Outdoor air hoods must be installed. No field wiring or assembly is required for standard outdoor dry bulb changeover operation. Field wiring of accessory sensors is required for different operational modes.

INSTALL OUTDOOR AIR HOODS — Perform the following procedure to install the outdoor-air hoods:

1. Economizer and barometric relief hoods are located in the condenser section under the slanted coil for shipping. See Fig. 14. Barometric relief/power exhaust hood is shipped inside of economizer hood. Remove screws that secure the wooden rails of the hood assemblies to the unit. Save screws. Slide complete assembly from condenser section.
2. Remove the screws that secure the economizer and barometric relief/power exhaust hoods to the wooden railing. Discard or recycle wooden rails. Save screws.
3. The barometric relief damper is secured to the economizer panel for shipping. Remove the screw holding the barometric relief damper to the panel. Damper should be free to swing open during operation. See Fig. 15.
4. Hang the barometric relief/power exhaust hood on the mounting flange on the economizer panel. Secure hood to panel with screws saved from Step 2. See Fig. 15 and 16.
5. Align hole in flange of economizer panel with left edge of hood. Hang economizer hood on the top flange of the economizer panel by rotating hood until top flange of the economizer hood engages the bent flange on the economizer panel. Rotate hood until hood is flush with the economizer panel. Hood will support itself from flange. Hood will support itself from flange. Align holes in hood with holes in panel and secure hood to panel with screws saved from Step 2. See Fig. 15 and 17.

ECONOMISER IV STANDARD SENSORS

Outdoor Air Temperature (OAT) Sensor — The outdoor air temperature sensor is a 10 to 20 mA device used to measure the outdoor-air temperature. The outdoor-air temperature is used to determine when the EconoMiSer IV can be used for free cooling. The sensor is factory-installed on the EconoMiSer IV in the outdoor airstream. The operating range of temperature measurement is 40 to 100 F.

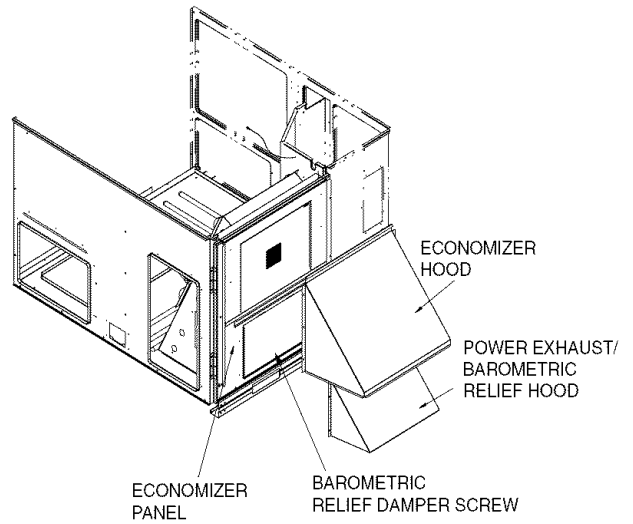

Fig. 15 — Hood Installation

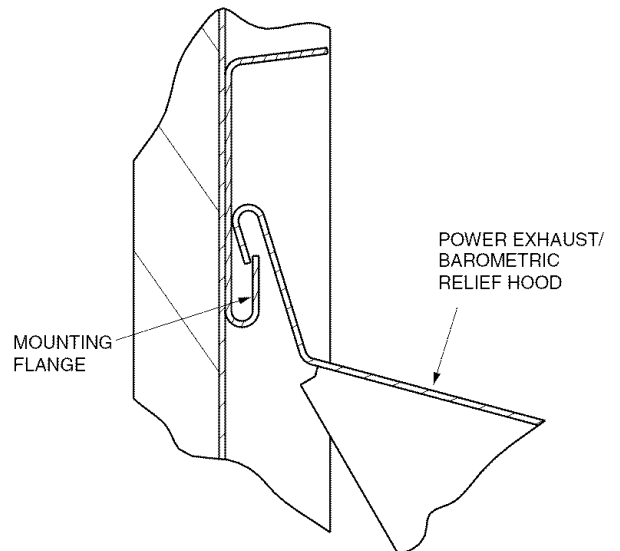

Fig. 16 — Barometric Relief/Power Exhaust Hood Flange

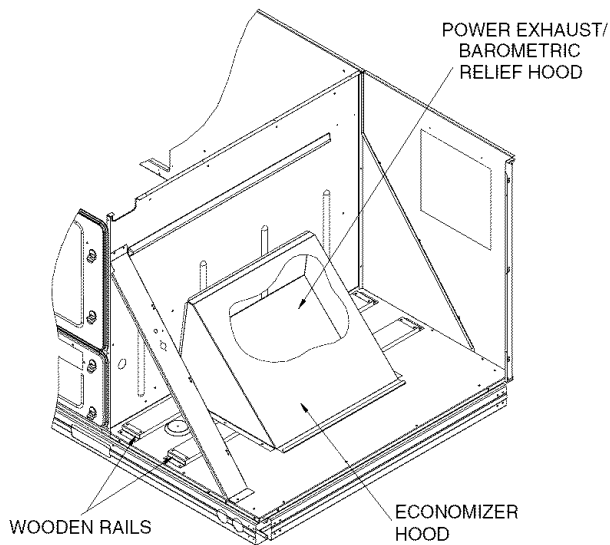

Fig. 14 — Economizer and Barometric Relief/Power Exhaust Hoods Shipping Positions

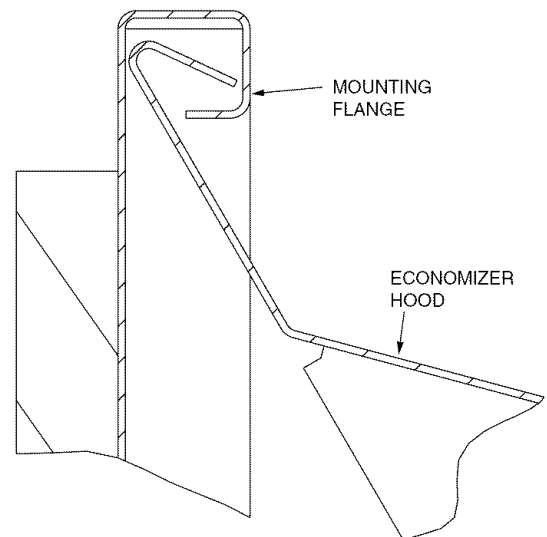

Fig. 17 — Economizer Flange

Mixed Air Temperature (MAT) Sensor — The mixed air temperature sensor is a 3 K thermistor located at the discharge of the indoor fan. The sensor is mounted through the side plate of the blower. The sensor has blue leads. This sensor is factory installed. The operating range of temperature measurement is 0° to 158 F.

Outdoor Air Lockout Sensor — The EconoMiSer IV is equipped with a temperature limit switch located in the outdoor airstream which is used to lock out the compressors below a 50 F ambient temperature.

ECONOMISER IV CONTROLLER WIRING AND OPERATIONAL MODES — Determine the EconoMiSer IV control mode before installing sensors and accessories. Different sensors are required for different control modes, and a number of accessories are available. Refer to Table 3. The EconoMiSer IV is supplied from the factory with a mixed air temperature sensor and an outdoor air temperature sensor. This allows for operation of the EconoMiSer IV with outdoor air dry bulb changeover control. Additional accessories can be added to allow for different types of changeover control and operation of the EconoMiSer IV and unit. See Fig. 18 for wiring.

Outdoor Dry Bulb Changeover — The standard controller is shipped from the factory configured for outdoor dry bulb changeover control. The outdoor air and mixed air temperature sensors are included as standard. For this control mode, the outdoor temperature is compared to an adjustable set point selected on the control. If the outdoor-air temperature is above the set point, the EconoMiSer IV will adjust the outside-air dampers to minimum position. If the outdoor-air temperature is below the set point, the position of the outside-air dampers will be controlled to provided free cooling using outdoor air. When in this mode, the LED next to the free cooling set point potentiometer will be on. The changeover temperature set point is controlled by the free cooling set point potentiometer located on the control. The scale on the potentiometer is A, B, C, and D. See Fig. 19 for the corresponding temperature changeover values.

Differential Dry Bulb Control — For differential dry bulb control the standard outdoor dry bulb sensor is used in conjunction with an additional accessory dry bulb sensor (part number CRTEMPN002A00). The accessory sensor must be mounted in the return airstream. Connect the return air temperature sensor to the S_R terminal (after removing the 620-ohm resistor) and to the + terminal on the controller. See Fig. 20.

In this mode of operation, the outdoor air temperature is compared to the return air temperature and the lower temperature airstream is used for cooling. When using this mode of changeover control, turn the enthalpy setpoint potentiometer fully clockwise to the D setting. See Fig. 21.

Outdoor Enthalpy Changeover — For enthalpy control, accessory enthalpy sensor (part number HH57AC078) is required. Replace the standard outdoor dry bulb temperature sensor with the accessory enthalpy sensor in the same mounting location. When the outdoor air enthalpy rises above the outdoor enthalpy changeover set point, the outdoor-air damper moves to its minimum position. The outdoor enthalpy changeover set point is set with the outdoor enthalpy set point potentiometer on the EconoMiSer IV controller. The set points are A, B, C, and D. See Fig. 22. The factory-installed 620-ohm jumper must be in place across terminals S_R and + on the EconoMiSer IV controller. See Fig. 20.

Differential Enthalpy Control — For differential enthalpy control, the EconoMiSer IV controller uses two enthalpy sensors (CRENTDIF004A00), one in the outside air and one in the return air duct. The EconoMiSer IV controller compares the outdoor air enthalpy to the return air enthalpy to determine EconoMiSer IV use. The controller selects the lower enthalpy air (return or outdoor) for cooling. For example, when the outdoor air has a lower enthalpy than the return air, the EconoMiSer IV opens to bring in outdoor air for free cooling.

Replace the standard outside air dry bulb temperature sensor with the accessory enthalpy sensor in the same mounting location. Mount the return air enthalpy sensor in the return air duct. The return air enthalpy sensor is wired to terminals S_R and + on the EconoMiSer IV controller. See Fig. 20. The outdoor enthalpy changeover set point is set with the outdoor enthalpy set point potentiometer on the EconoMiSer IV controller. When using this mode of changeover control, turn the enthalpy set point potentiometer fully clockwise to the D setting.

Indoor Air Quality (IAQ) Sensor Input — The IAQ input can be used for demand control ventilation control based on the level of CO₂ measured in the space or return air duct.

Mount the optional IAQ sensor according to manufacturer specifications. The IAQ sensor should be wired to the AQ and AQ1 terminals of the controller. Adjust the DCV potentiometers to correspond to the DCV voltage output of the indoor air quality sensor at the user-determined set point. See Fig. 23.

If a separate field-supplied transformer is used to power the IAQ sensor, the sensor must not be grounded or the EconoMiSer IV control board will be damaged. See Fig. 18.

Power Exhaust — The factory-installed power exhaust will be factory wired and installed. If an accessory power exhaust is to be installed, see the accessory power exhaust installation instructions included with the power exhaust for installation and wiring. The wiring plug on the power exhaust is connected to wiring harness plug PL1-3,4.

Table 3 — EconoMiSer IV Sensor Usage

APPLICATION	ECONOMISER IV WITH OUTDOOR AIR DRY BULB SENSOR			ECONOMISER IV WITH SINGLE ENTHALPY SENSOR		
	Accessories Required			Accessories Required		
Outdoor Air Dry Bulb	None. The outdoor air dry bulb sensor is factory installed.			CRTEMPN002A00*		
Differential Dry Bulb	CRTEMPN002A00*			(2) CRTEMPN002A00*		
Single Enthalpy	HH57AC078			None. The single enthalpy sensor is factory installed.		
Differential Enthalpy	HH57AC078 and CRENTDIF004A00*			CRENTDIF004A00*		
CO ₂ for DCV Control using a Wall-Mounted CO ₂ Sensor	33ZCSENCO2			33ZCSENCO2		
CO ₂ for DCV Control using a Duct-Mounted CO ₂ Sensor	33ZCSENCO2† and 33ZCASPCO2**	⌘	CRCBDIOX005A00††	33ZCSENCO2† and 33ZCASPCO2**	⌘	CRCBDIOX005A00††

*CRENTDIF004A00 and CRTEMPN002A00 accessories are used on many different base units. As such, these kits may contain parts that will not be needed for installation.
†33ZCSENCO2 is an accessory CO₂ sensor.

**33ZCASPCO2 is an accessory aspirator box required for duct-mounted applications.
††CRCBDIOX005A00 is an accessory that contains both 33ZCSENCO2 and 33ZCASPCO2 accessories.

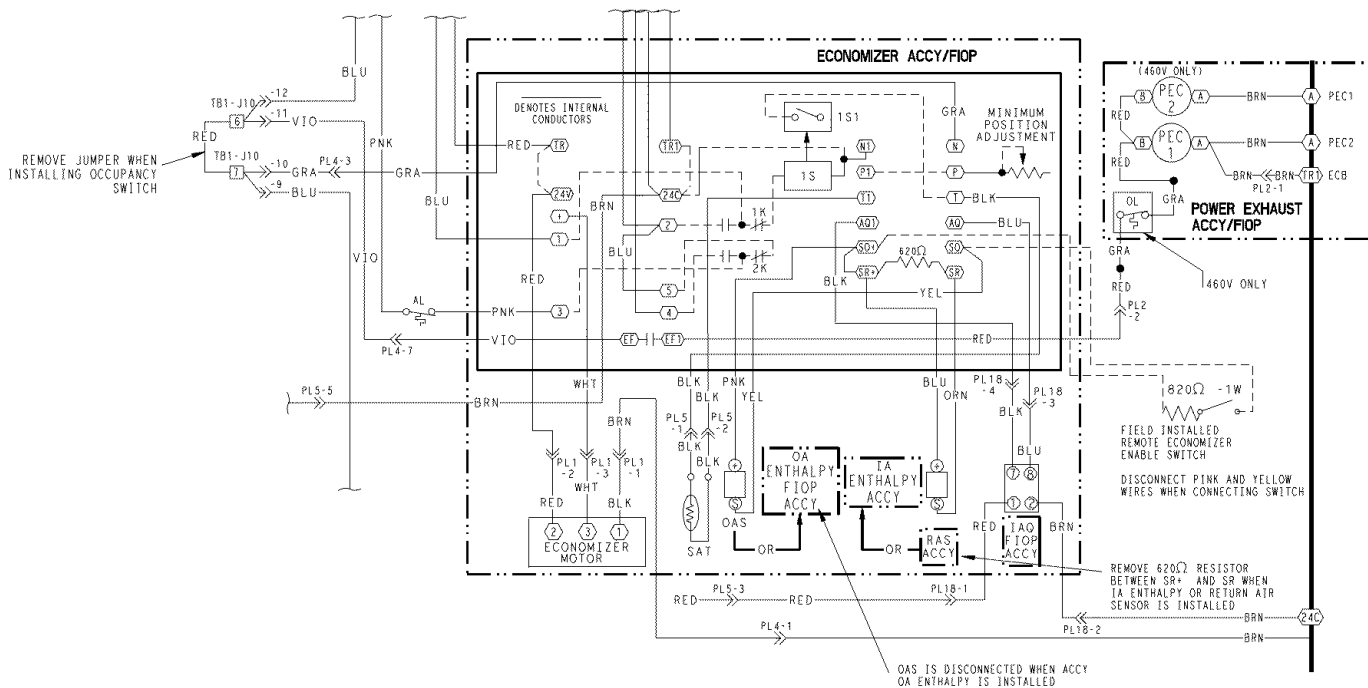

NOTE: See page 45 for Legend.

Fig. 18 — EconMiSer IV Wiring

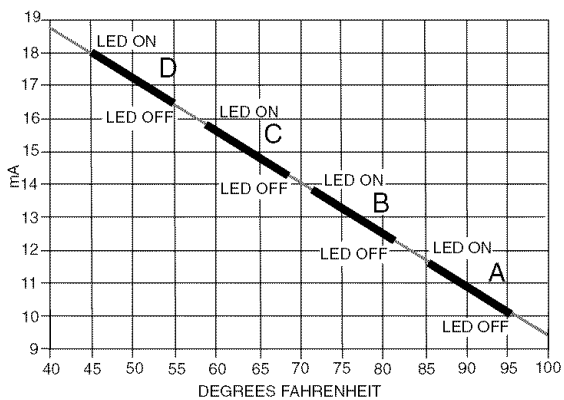

Fig. 19 — Temperature Changeover Set Points

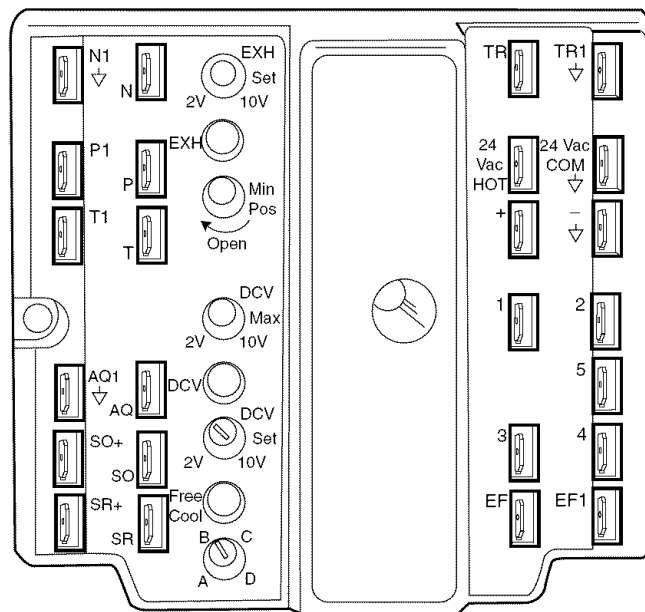

Fig. 20 — EconMiSer IV Control

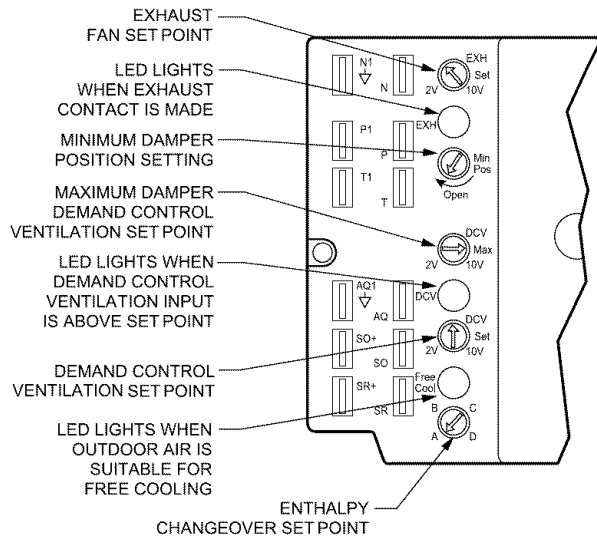

Fig. 21 — EconMiSer IV Controller Potentiometer and LED Locations

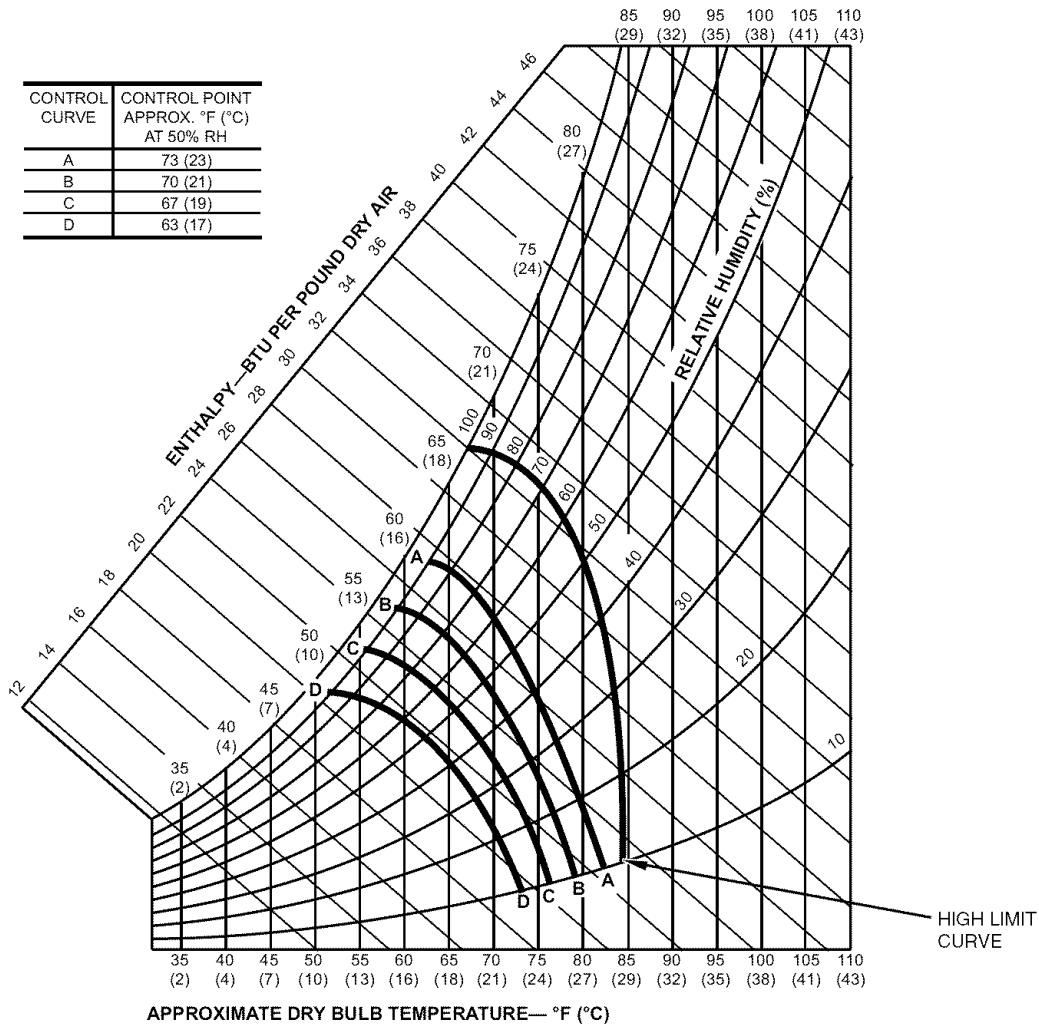

Fig. 22 — Enthalpy Changeover Set Points

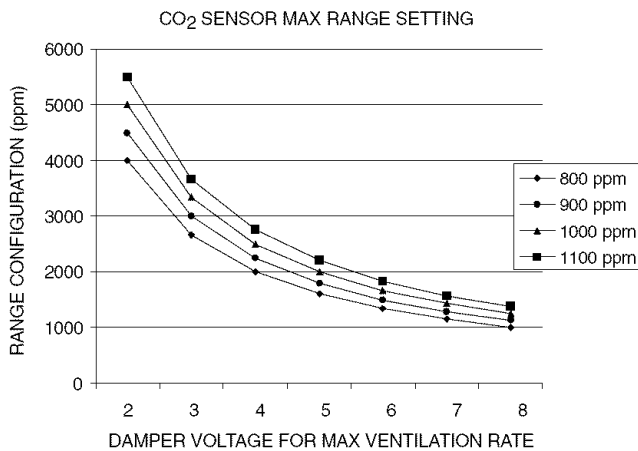

Fig. 23 — CO₂ Sensor Maximum Range Setting

Exhaust Set Point Adjustment — The exhaust set point will determine when the exhaust fan runs based on damper position (if accessory power exhaust is installed). The set point is modified with the Exhaust Fan Set Point (EXH SET) potentiometer. The set point represents the damper position above which the exhaust fans will be turned on. When there is a call for exhaust, the EconoMi\$er IV controller provides a 45 ± 15 second delay before exhaust fan activation to allow the dampers to open. This delay allows the damper to reach the appropriate position to avoid unnecessary fan overload.

Minimum Position Control — There is a minimum damper position potentiometer on the EconoMi\$er IV controller. See Fig. 21. The minimum damper position maintains the minimum airflow into the building during the occupied period.

When using demand ventilation, the minimum damper position represents the minimum ventilation position for VOC (volatile organic compounds) ventilation requirements. The maximum demand ventilation position is used for fully occupied ventilation.

When demand ventilation control is not being used, the minimum position potentiometer should be used to set the occupied ventilation position. The maximum demand ventilation position should be turned fully clockwise.

Adjust the minimum position potentiometer to allow the minimum amount of outdoor air, as required by local codes, to enter the building. Make minimum position adjustments with at least 10° F temperature difference between the outdoor and return-air temperatures.

To determine the minimum position setting, perform the following procedure:

1. Calculate the appropriate mixed-air temperature using the following formula:

$$(T_O \times OA) + (T_R \times RA) = T_M$$

T_O = Outdoor-Air Temperature
 OA = Percent of Outdoor Air
 T_R = Return-Air Temperature
 RA = Percent of Return Air
 T_M = Mixed-Air Temperature

As an example, if local codes require 10% outdoor air during occupied conditions, outdoor-air temperature is 60 F, and return-air temperature is 75 F.

$$(60 \times .10) + (75 \times .90) = 73.5 \text{ F}$$

2. Disconnect the mixed-air sensor from terminals T and T1.
3. Ensure that the factory-installed jumper is in place across terminals P and P1. If remote damper positioning is being used, make sure that the terminals are wired according to

Fig. 18 and that the minimum position potentiometer is turned fully clockwise.

4. Connect 24 vac across terminals TR and TR1.
5. Carefully adjust the minimum position potentiometer until the measured mixed air temperature matches the calculated value.
6. Reconnect the mixed air sensor to terminals T and T1.

Remote control of the EconoMi\$er IV damper is desirable when requiring additional temporary ventilation. If a field-supplied remote potentiometer (Honeywell part number S963B1128) is wired to the EconoMi\$er IV controller, the minimum position of the damper can be controlled from a remote location.

To control the minimum damper position remotely, remove the factory-installed jumper on the P and P1 terminals on the EconoMi\$er IV controller. Wire the field-supplied potentiometer to the P and P1 terminals on the EconoMi\$er IV controller. See Fig. 20.

Damper Movement — When the EconoMi\$er IV board receives initial power, it can take the damper up to 2½ minutes before it begins to position itself. After the initial positioning, subsequent changes to damper position will take up to 30 seconds to initiate. Damper movement from full open to full closed (or vice versa) takes 2½ minutes.

Thermostats — The EconoMi\$er IV control works with conventional thermostats that have a Y1 (cool stage 1), Y2 (cool stage 2), W1 (heat stage 1), W2 (heat stage 2), and G (fan). The EconoMi\$er IV control does not support space temperature sensors. Connections are made at the thermostat terminal connection board located in the main control box.

Pressure Drop — See Fig. 24 and 25 for EconoMi\$er IV pressure drop. Evaporator fan may need to be adjusted.

Demand Control Ventilation (DCV) — When using the EconoMi\$er IV for demand control ventilation, there are some equipment selection criteria which should be considered. When selecting the heat capacity and cool capacity of the equipment, the maximum ventilation rate must be evaluated for design conditions. The maximum damper position must be calculated to provide the desired fresh air.

Typically the maximum ventilation rate will be about 5 to 10% more than the typical cfm required per person, using normal outside air design criteria.

A proportional anticipatory strategy should be taken with the following conditions: a zone with a large area, varied occupancy, and equipment that cannot exceed the required ventilation rate at design conditions. Exceeding the required ventilation rate means the equipment can condition air at a maximum ventilation rate that is greater than the required ventilation rate for maximum occupancy. A proportional-anticipatory strategy will cause the fresh air supplied to increase as the room CO₂ level increases even though the CO₂ set point has not been reached. By the time the CO₂ level reaches the set point, the damper will be at maximum ventilation and should maintain the set point.

In order to have the CO₂ sensor control the economizer damper in this manner, first determine the damper voltage output for minimum or base ventilation. Base ventilation is the ventilation required to remove contaminants during unoccupied periods. The following equation may be used to determine the percent of outside air entering the building for a given damper position. For best results there should be at least a 10 degree difference in outside and return-air temperatures.

$$(T_O \times OA) + (T_R \times RA) = T_M$$

T_O = Outdoor-Air Temperature
 OA = Percent of Outdoor Air
 T_R = Return-Air Temperature
 RA = Percent of Return Air
 T_M = Mixed-Air Temperature

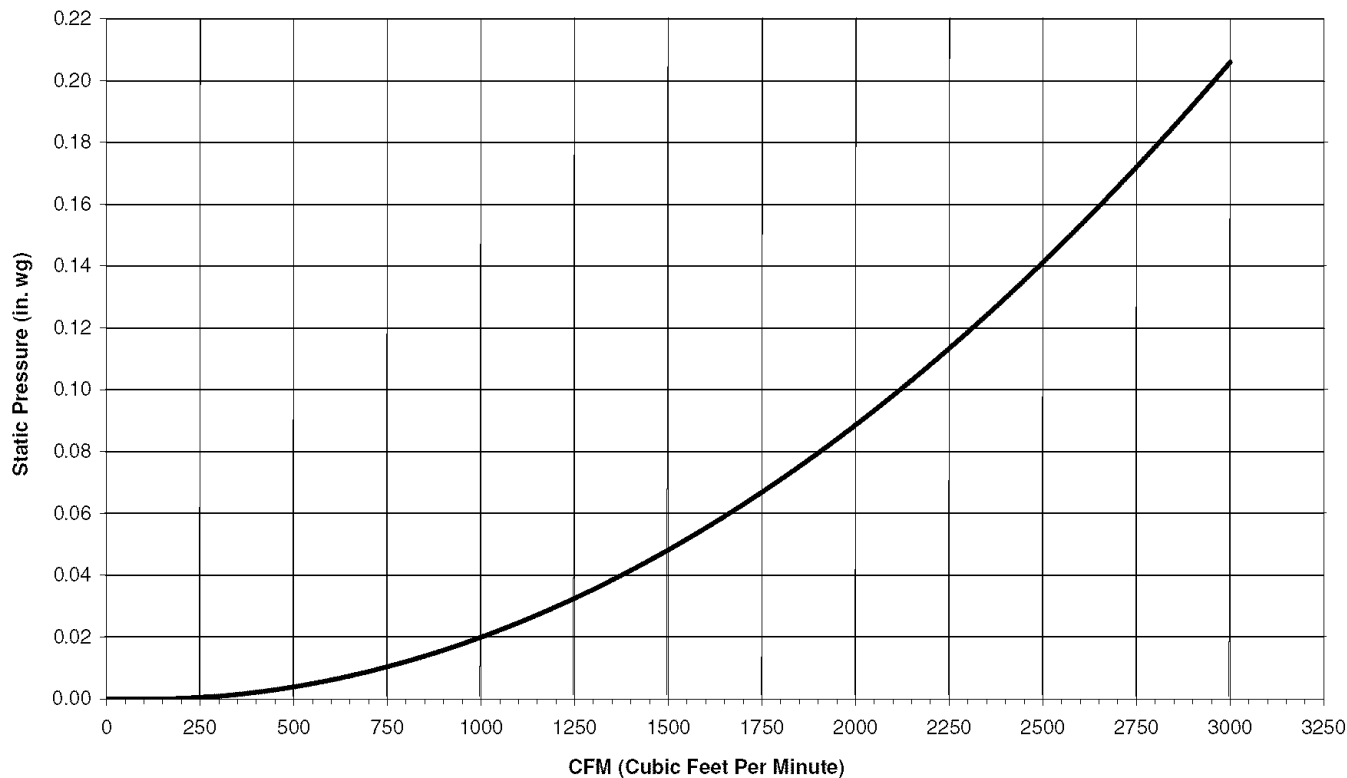

NOTE: Economizer damper pressure drop is with outdoor air damper totally closed and return air damper fully open.

Fig. 24 — Pressure Drop for Vertical Economizer

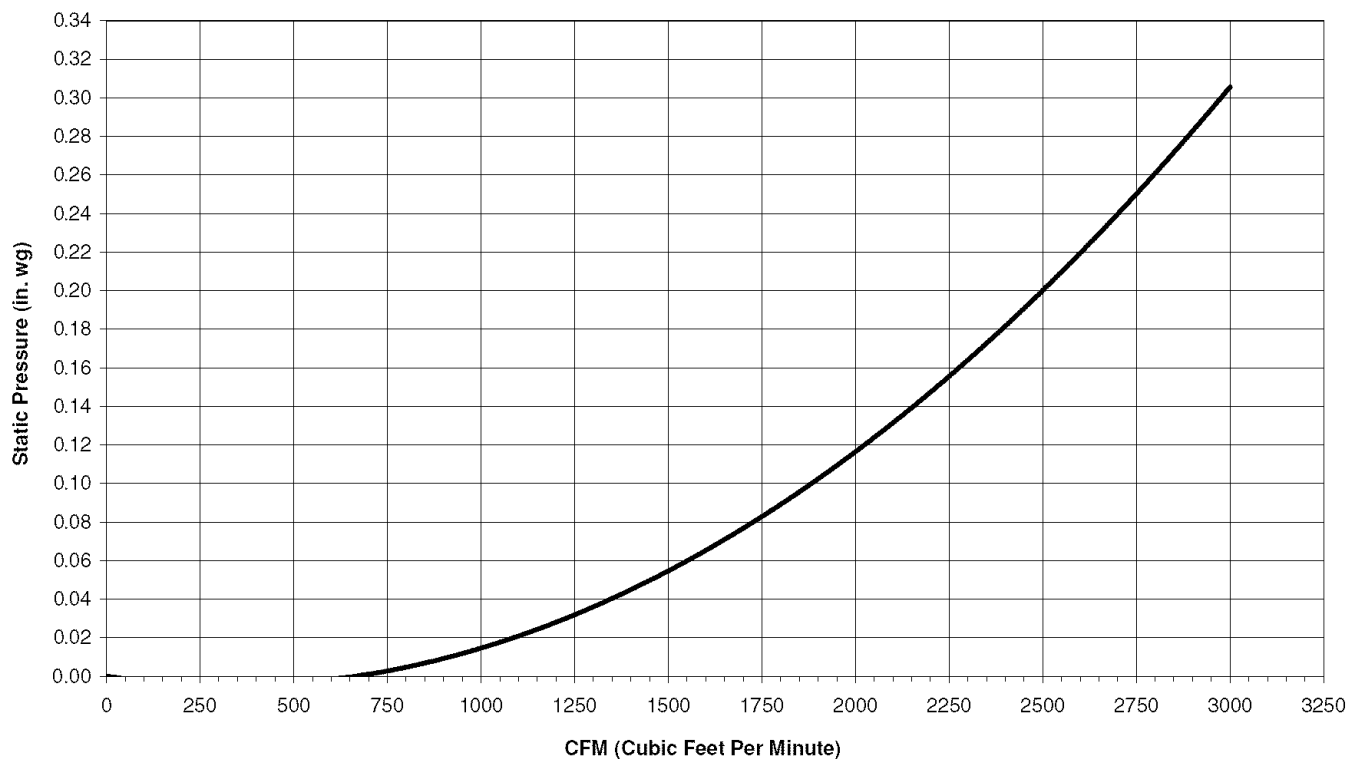

NOTE: Economizer damper pressure drop is with outdoor air damper totally closed and return air damper fully open.

Fig. 25 — Pressure Drop for Horizontal Economizer

Once base ventilation has been determined, set the minimum damper position potentiometer to the correct position.

The same equation can be used to determine the occupied or maximum ventilation rate to the building. For example, an output of 3.6 volts to the actuator provides a base ventilation rate of 5% and an output of 6.7 volts provides the maximum ventilation rate of 20% (or base plus 15 cfm per person). Use Fig. 23 to determine the maximum setting of the CO₂ sensor. For example, a 1100 ppm set point relates to a 15 cfm per person design. Use the 1100 ppm curve on Fig. 23 to find the point when the CO₂ sensor output will be 6.7 volts. Line up the point on the graph with the left side of the chart to determine that the range configuration for the CO₂ sensor should be 1800 ppm. The EconoMiSer IV controller will output the 6.7 volts from the CO₂ sensor to the actuator when the CO₂ concentration in the space is at 1100 ppm. The DCV set point may be left at 2 volts since the CO₂ sensor voltage will be ignored by the EconoMiSer IV controller until it rises above the 3.6 volt setting of the minimum position potentiometer.

Once the fully occupied damper position has been determined, set the maximum damper demand control ventilation potentiometer to this position. Do not set to the maximum position as this can result in over-ventilation to the space and potential high humidity levels.

CO₂ Sensor Configuration — The CO₂ sensor has preset standard voltage settings that can be selected anytime after the sensor is powered up. See Table 4.

Use setting 1 or 2 for Carrier equipment.

1. Press Clear and Mode buttons. Hold at least 5 seconds until the sensor enters the Edit mode.
2. Press Mode twice. The STDSET Menu will appear.
3. Use the Up/Down button to select the preset number. See Table 4.
4. Press Enter to lock in the selection.
5. Press Mode to exit and resume normal operation.

The custom settings of the CO₂ sensor can be changed anytime after the sensor is energized. Follow the steps below to change the non-standard settings:

1. Press Clear and Mode buttons. Hold at least 5 seconds until the sensor enters the Edit mode.
2. Press Mode twice. The STDSET Menu will appear.

3. Use the Up/Down button to toggle to the NONSTD menu and press Enter.
4. Use the Up/Down button to toggle through each of the nine variables, starting with Altitude, until the desired setting is reached.
5. Press Mode to move through the variables.
6. Press Enter to lock in the selection, then press Mode to continue to the next variable.

Dehumidification of Fresh Air with DCV (Demand Controlled Ventilation) Control — Information from ASHRAE (American Society of Heating, Refrigeration, and Air Conditioning Engineers) indicates that the largest humidity load on any zone is the fresh air introduced. For some applications, a device such as a 62AQ energy recovery unit is added to reduce the moisture content of the fresh air being brought into the building when the enthalpy is high. In most cases, the normal heating and cooling processes are more than adequate to remove the humidity loads for most commercial applications.

This makes the control of the of the dehumidification device simple when using the enthalpy or differential enthalpy sensor. The enthalpy sensor or differential enthalpy sensor is installed on the equipment to determine economizer operation. The high enthalpy signal from the enthalpy sensor or differential enthalpy sensor can be used to turn on the outdoor air moisture removal device any time fresh air is required for the space.

The energy recovery device should be sized for maximum latent and sensible conditioning at maximum ventilation on a design day. A calculation for leaving-air temperature on a low ambient, low ventilation day should also be done to determine the mixed-air temperature of the return and pre-conditioned outside air. The design should produce an air temperature somewhat near room conditions to prevent reheat of the air mixture. The energy recovery device should be interlocked with the heat to turn off the device when in the heat mode.

Step 11 — Install All Accessories — After all of the factory-installed options have been adjusted, install all field-installed accessories. Refer to the accessory installation instructions included with each accessory. Consult the Carrier Price Pages or RTU (rooftop unit) Building software for accessory package numbers for particular applications.

Table 4 — CO₂ Sensor Standard Settings

SETTING	EQUIPMENT	OUTPUT	VENTILATION RATE (cfm/Person)	ANALOG OUTPUT	CO ₂ CONTROL RANGE (ppm)	OPTIONAL RELAY SETPOINT (ppm)	RELAY HYSTERESIS (ppm)
1	Interface With Standard Building Control System	Proportional	Any	0-10V 4-20 mA	0-2000	1000	50
2		Proportional	Any	2-10V 7-20 mA	0-2000	1000	50
3		Exponential	Any	0-10V 4-20 mA	0-2000	1100	50
4	Economizer	Proportional	15	0-10V 4-20 mA	0-1100	1100	50
5		Proportional	20	0-10V 4-20 mA	0- 900	900	50
6		Exponential	15	0-10V 4-20 mA	0-1100	1100	50
7		Exponential	20	0-10V 4-20 mA	0- 900	900	50
8	Health and Safety	Proportional	—	0-10V 4-20 mA	0-9999	5000	500
9	Parking/Air Intakes/ Loading Docks	Proportional	—	0-10V 4-20 mA	0-2000	700	50

PRE-START-UP

⚠ WARNING

Failure to observe the following warnings could result in serious personal injury:

1. Follow recognized safety practices and wear protective goggles when checking or servicing refrigerant system.
2. Do not operate compressor or provide any electric power to unit unless compressor terminal cover is in place and secured.
3. Do not remove compressor terminal cover until all electrical sources are disconnected.
4. Relieve all pressure from system before touching or disturbing anything inside terminal box if refrigerant leak is suspected around compressor terminals.
5. Never attempt to repair soldered connection while refrigerant system is under pressure.
6. Do not use torch to remove any component. System contains oil and refrigerant under pressure. To remove a component, wear protective goggles and proceed as follows:
 - a. Shut off gas to unit and then electrical power.
 - b. Reclaim or recover refrigerant to relieve all pressure from system using both high-pressure and low-pressure ports.
 - c. Cut component connection tubing with tubing cutter and remove component from unit.
 - d. Carefully unsweat remaining tubing stubs when necessary. Oil can ignite when exposed to torch flame.

Proceed as follows to inspect and prepare the unit for initial start-up:

1. Remove all access panels.
2. Read and follow instructions on all WARNING, CAUTION, and INFORMATION labels attached to, or shipped with, unit.
3. Make the following inspections:
 - a. Inspect for shipping and handling damages such as broken lines, loose parts, or disconnected wires, etc.
 - b. Inspect for oil at all refrigerant tubing connections and on unit base. Detecting oil generally indicates a refrigerant leak. Leak-test all refrigerant tubing connections using electronic leak detector, halide torch, or liquid-soap solution.
 - c. Inspect all field-wiring and factory-wiring connections. Be sure that connections are completed and tight. Be sure that wires are not in contact with refrigerant tubing or sharp edges.
 - d. Inspect coil fins. If damaged during shipping and handling, carefully straighten fins with a fin comb.
4. Verify the following conditions:
 - a. Make sure that condenser-fan blades are correctly positioned in fan orifice. See Condenser-Fan Adjustment section on page 39 for more details.
 - b. Make sure that air filter(s) is in place.
 - c. Make sure that condensate drain trap is filled with water to ensure proper drainage.
 - d. Make sure that all tools and miscellaneous loose parts have been removed.

START-UP

Unit Preparation — Make sure that unit has been installed in accordance with installation instructions and applicable codes.

Gas Piping — Check gas piping for leaks.

⚠ WARNING



Disconnect gas piping from unit when leak testing at pressure greater than 1/2 psig. Pressures greater than 1/2 psig will cause gas valve damage resulting in hazardous condition. If gas valve is subjected to pressure greater than 1/2 psig, it *must* be replaced before use. When pressure testing field-supplied gas piping at pressures of 1/2 psig or less, a unit connected to such piping must be isolated by manually closing the gas valve.

Return-Air Filters — Make sure correct filters are installed in unit (see Table 1). Do not operate unit without return-air filters.

Outdoor-Air Inlet Screens — Outdoor-air inlet screen must be in place before operating unit.

Compressor Mounting — Compressors are internally spring mounted. Do not loosen or remove compressor hold-down bolts.

Crankcase Heaters — Crankcase heaters are energized as long as there is power to the unit, the compressor is not operating, and ambient temperature is below 75 F.

Internal Wiring — Check all electrical connections in unit control boxes. Tighten as required.

Refrigerant Service Ports — Each unit system has 4 Schrader-type service ports: one on the suction line, two on the liquid line, and one on the compressor discharge line. Be sure that caps on the ports are tight.

High Flow Refrigerant Valves — Three high flow valves are located on the hot gas tube coming out of the compressor, the suction tube going into the compressor, and the liquid line leaving the condenser. Large black plastic caps identify these valves. These valves have O-rings inside which screw the cap onto a brass body to prevent leaks. No field access to these valves is available at this time. Ensure the plastic caps remain on the valves and are tight or the possibility of refrigerant leakage could occur.

Compressor Rotation — On 3-phase units with scroll compressors, it is important to be certain compressor is rotating in the proper direction. To determine whether or not compressor is rotating in the proper direction:

1. Connect service gages to suction and discharge pressure fittings.
2. Energize the compressor.
3. The suction pressure should drop and the discharge pressure should rise, as is normal on any start-up.

If the suction pressure does not drop and the discharge pressure does not rise to normal levels:

1. Note that the evaporator fan (size 006 and 007 only) is probably also rotating in the wrong direction.
2. Turn off power to the unit and install lockout tag.
3. Reverse any two of the unit power leads.
4. Reenergize to the compressor. Check pressures.

The suction and discharge pressure levels should now move to their normal start-up levels.

NOTE: When the compressor is rotating in the wrong direction, the unit will make an elevated level of noise and will not provide cooling.

Evaporator Fan — Fan belt and variable pitch pulleys are factory-installed. See Tables 5-30 for fan performance data. Be sure that fans rotate in the proper direction. See Table 31 for air quantity limits. See Table 32 for evaporator fan motor specifications. See Table 33 for fan rpm at various motor pulley settings. To alter fan performance, see Evaporator Fan Performance Adjustment section on page 39.

Cooling — Set space thermostat to OFF position. To start unit, turn on main power supply. Set system selector switch at COOL position and fan switch at AUTO. position. Adjust thermostat to a setting below room temperature. Compressor starts on closure of contactor.

Check unit charge. Refer to Refrigerant Charge section on page 40.

Reset thermostat at a position above room temperature. Compressor will shut off. Evaporator fan will shut off after a 30-second delay.

TO SHUT OFF UNIT — Set system selector switch at OFF position. Resetting thermostat at a position above room temperature shuts unit off temporarily until space temperature exceeds thermostat setting. Units are equipped with Cycle-LOC™ protection device. Unit shuts down on any safety trip, and indicator light on thermostat comes on. Check reason for all safety trips.

Compressor restart is accomplished by manual reset at the thermostat by turning the selector switch to OFF and then to ON position.

Main Burners — Main burners are factory set and should require no adjustment.

TO CHECK ignition of main burners and heating controls, move thermostat set point above room temperature and verify that the burners light and evaporator fan is energized. Check heating effect, then lower the thermostat setting below the room temperature and verify that the burners and evaporator fan turn off.

Heating

1. Purge gas supply line of air by opening union ahead of the gas valve. If gas odor is detected, tighten union and wait 5 minutes before proceeding.
2. Turn on electrical supply and manual gas valve.
3. Set system switch selector at HEAT position and fan switch at AUTO. or ON position. Set heating temperature lever above room temperature.
4. The induced-draft motor will start.
5. After a call for heating, the main burners should light within 5 seconds. If the burner does not light, then there is a 22-second delay before another 5-second try. If the burner still does not light, the time delay is repeated. If the burner does not light within 15 minutes, there is a lock-out. To reset the control, break the 24 v power to W1.
6. The evaporator-fan motor will turn on 45 seconds after burner ignition.
7. The evaporator-fan motor will turn off in 45 seconds after the thermostat temperature is satisfied.
8. Adjust airflow to obtain a temperature rise within the range specified on the unit nameplate.

NOTE: The default value for the evaporator-fan motor on/off delay is 45 seconds. The Integrated Gas Unit Controller (IGC) modifies this value when abnormal limit switch cycles occur. Based upon unit operating conditions, the on delay can be

reduced to 0 seconds and the off delay can be extended to 180 seconds. When one flash of the LED (light-emitting diode) is observed, the evaporator-fan on/off delay has been modified.

If the limit switch trips at the start of the heating cycle during the evaporator on delay, the time period of the on delay for the next cycle will be 5 seconds less than the time at which the switch tripped. (Example: If the limit switch trips at 30 seconds, the evaporator-fan on delay for the next cycle will occur at 25 seconds.) To prevent short-cycling, a 5-second reduction will only occur if a minimum of 10 minutes has elapsed since the last call for heating.

The evaporator-fan off delay can also be modified. Once the call for heating has ended, there is a 10-minute period during which the modification can occur. If the limit switch trips during this period, the evaporator-fan off delay will increase by 15 seconds. A maximum of 9 trips can occur, extending the evaporator-fan off delay to 180 seconds.

To restore the original default value, reset the power to the unit.

TO SHUT OFF UNIT — Set system selector switch at off position. Resetting heating selector lever below room temperature will temporarily shut unit off until space temperature falls below thermostat setting.

Safety Relief — A soft-solder joint at the suction service Schrader port provides pressure relief under abnormal temperature and pressure conditions.

Ventilation (Continuous Fan) — Set fan and system selector switches at ON and OFF positions, respectively. Evaporator fan operates continuously to provide constant air circulation. When the evaporator-fan selector switch is turned to the OFF position, there is a 30-second delay before the fan turns off.

Operating Sequence

COOLING, UNITS WITHOUT ECONOMIZER — When thermostat calls for cooling, terminals G and Y1 are energized. The indoor-fan contactor (IFC) and compressor contactor (CA.1) are energized and indoor-fan motor, compressor, and outdoor fan starts. The outdoor-fan motor runs continuously while unit is cooling.

When the thermostat is satisfied, Y1 and G deenergize. The compressor stops immediately and the indoor fan will continue to operate for 30 to 45 seconds.

HEATING, UNITS WITHOUT ECONOMIZER — When the thermostat calls for heating, terminal W1 is energized. To prevent thermostat short-cycling, the unit is locked into the Heating mode for at least 1 minute when W1 is energized. The induced-draft motor is energized and the burner ignition sequence begins. The indoor (evaporator) fan motor (IFM) is energized 45 seconds after a flame is ignited. On units equipped for two stages of heat, when additional heat is needed, W2 (if equipped) is energized and the high-fire solenoid on the main gas valve (MGV) is energized. When the thermostat is satisfied and W1 is deenergized, the IFM stops after a 45-second time-off delay.

COOLING, UNITS WITH ECONOMIZER IV — When free cooling is not available, the compressors will be controlled by the zone thermostat. When free cooling is available, the outdoor-air damper is modulated by the EconoMi\$er IV control to provide a 50 to 55 F mixed-air temperature into the zone. As the mixed-air temperature fluctuates above 55 or below 50 F, the dampers will be modulated (open or close) to bring the mixed-air temperature back within control.

If the load is high and Y2 is energized, then the first stage of mechanical cooling will be used to supplement the free cooling provided by the economizer. If mechanical cooling is utilized with free cooling, the outdoor-air damper will maintain its current position at the time the compressor is started. If the

increase in cooling capacity causes the mixed-air temperature to drop below 45 F, then the outdoor-air damper position will be decreased to the minimum position. If the mixed-air temperature continues to fall, the outdoor-air damper will close. Control returns to normal once the mixed-air temperature rises above 48 F.

If optional power exhaust is installed, as the outdoor-air damper opens and closes, the power exhaust fans will be energized and deenergized if the position goes above or below the power exhaust set point. When the exhaust fan is required to be on, the LED on the control will be energized.

If field-installed accessory CO₂ sensors are connected to the EconoMi\$er IV control, a demand controlled ventilation strategy will begin to operate. As the CO₂ level in the zone increases above the CO₂ set point, the minimum position of the damper will be increased proportionally from the minimum damper position to the maximum demand ventilation damper position. As the CO₂ level decreases because of the increase in fresh air, the outdoor-air damper will be proportionally closed.

If there is no G signal then the control will drive the damper to the fully closed position.

The control is also equipped with an occupied/unoccupied input. If the input is closed, then the damper will be driven to the minimum position when G is energized. If the input is open then the damper will remain in the fully closed position unless there is a demand for free cooling of DCV ventilation.

On the initial power to the EconoMi\$er IV control, it will take the damper up to 2½ minutes before it begins to position itself. Any change in damper position will take up to 30 seconds to initiate. Damper movement from full closed to full open (or vice versa) will take between 1½ and 2½ minutes.

If free cooling can be used as determined from the appropriate changeover command (switch, dry bulb, enthalpy curve, differential dry bulb, or differential enthalpy), then the control will modulate the dampers open to maintain the mixed-air temperature set point at 50 to 55 F.

If there is a further demand for cooling (cooling second stage — Y2 is energized), then the control will bring on compressor stage 1 to maintain the mixed-air temperature set point. The EconoMi\$er IV damper will be open at maximum position. EconoMi\$er IV operation is limited to a single compressor.

HEATING UNITS WITH ECONOMISER IV — When the room temperature calls for heat, the heating controls are energized as described in the Heating, Units Without Economizer section. The IFM is energized and the EconoMi\$er IV damper modulates to the minimum position. When the thermostat is satisfied, the damper modulates closed.

Table 5 — Fan Performance — 48PGF/N03 Vertical Units

AIRFLOW (Cfm)	AVAILABLE EXTERNAL STATIC PRESSURE (in. wg)									
	0.2		0.4		0.6		0.8		1.0	
	Rpm	Bhp	Rpm	Bhp	Rpm	Bhp	Rpm	Bhp	Rpm	Bhp
600	407	0.05	551	0.10	663	0.15	759	0.21	843	0.27
650	413	0.06	555	0.11	667	0.17	763	0.22	847	0.29
700	419	0.06	560	0.12	671	0.18	766	0.24	851	0.30
750	425	0.07	565	0.13	676	0.19	770	0.25	854	0.32
800	433	0.08	570	0.14	680	0.20	774	0.27	858	0.34
850	440	0.08	575	0.15	685	0.22	779	0.29	862	0.36
900	448	0.09	581	0.16	690	0.23	783	0.30	866	0.38
950	456	0.10	587	0.17	695	0.24	788	0.32	871	0.40
1000	465	0.11	594	0.18	700	0.26	792	0.34	875	0.42

AIRFLOW (Cfm)	AVAILABLE EXTERNAL STATIC PRESSURE (in. wg)									
	1.2		1.4		1.6		1.8		2.0	
	Rpm	Bhp	Rpm	Bhp	Rpm	Bhp	Rpm	Bhp	Rpm	Bhp
600	920	0.33	990	0.40	1056	0.47	1117	0.54	1176	0.62
650	923	0.35	994	0.42	1059	0.49	1121	0.57	1179	0.65
700	927	0.37	997	0.44	1063	0.52	1124	0.60	1182	0.68
750	931	0.39	1001	0.47	1066	0.54	1128	0.62	1186	0.71
800	934	0.41	1004	0.49	1070	0.57	1131	0.65	1189	0.74
850	938	0.44	1008	0.52	1073	0.60	1135	0.68	1193	0.77
900	942	0.46	1012	0.54	1077	0.63	1138	0.71	1196	0.80
950	946	0.48	1016	0.57	1081	0.65	1142	0.74	1200	0.83
1000	950	0.51	1020	0.59	1085	0.68	1146	0.78	1204	0.87

LEGEND

Bhp — Brake Horsepower
 ■ Field-Supplied Motor Required

NOTES:

1. Motor drive range is 482 to 736 rpm for low range motor/drive and 656 to 1001 rpm for high range motor/drive. All other rpms require a field-supplied drive.
2. Maximum continuous bhp is 0.85 for low range motor/drive and 0.85 for high range motor/drive.
3. See page 35 for General Fan Performance Notes.

Table 6 — Fan Performance — 48PGD/L04 Vertical Units

AIRFLOW (Cfm)	AVAILABLE EXTERNAL STATIC PRESSURE (in. wg)									
	0.2		0.4		0.6		0.8		1.0	
	Rpm	Bhp	Rpm	Bhp	Rpm	Bhp	Rpm	Bhp	Rpm	Bhp
900	448	0.09	581	0.16	690	0.23	783	0.30	866	0.38
950	456	0.10	587	0.17	695	0.24	788	0.32	871	0.40
1000	465	0.11	594	0.18	700	0.26	792	0.34	875	0.42
1050	474	0.12	600	0.20	706	0.27	797	0.36	880	0.44
1100	483	0.13	607	0.21	711	0.29	803	0.38	884	0.46
1150	493	0.14	614	0.22	717	0.31	808	0.40	889	0.49
1200	503	0.16	622	0.24	724	0.33	813	0.42	894	0.51
1250	513	0.17	630	0.25	730	0.34	819	0.44	899	0.54
1300	524	0.19	638	0.27	737	0.36	825	0.46	905	0.56
1350	535	0.20	646	0.29	744	0.38	831	0.48	910	0.59
1400	546	0.22	655	0.31	751	0.41	837	0.51	916	0.61
1450	557	0.24	664	0.33	759	0.43	844	0.53	922	0.64
1500	569	0.25	673	0.35	766	0.45	851	0.56	928	0.67

AIRFLOW (Cfm)	AVAILABLE EXTERNAL STATIC PRESSURE (in. wg)									
	1.2		1.4		1.6		1.8		2.0	
	Rpm	Bhp	Rpm	Bhp	Rpm	Bhp	Rpm	Bhp	Rpm	Bhp
900	942	0.46	1012	0.54	1077	0.63	1138	0.71	1196	0.80
950	946	0.48	1016	0.57	1081	0.65	1142	0.74	1200	0.83
1000	950	0.51	1020	0.59	1085	0.68	1146	0.78	1204	0.87
1050	955	0.53	1024	0.62	1089	0.71	1150	0.81	1207	0.90
1100	959	0.56	1028	0.65	1093	0.74	1154	0.84	1211	0.94
1150	963	0.58	1032	0.68	1097	0.78	1158	0.88	1215	0.98
1200	968	0.61	1037	0.71	1101	0.81	1162	0.91	1219	1.02
1250	973	0.64	1041	0.74	1105	0.84	1166	0.95	1223	1.06
1300	978	0.66	1046	0.77	1110	0.88	1170	0.98	1227	1.10
1350	983	0.69	1051	0.80	1115	0.91	1175	1.02	1232	1.14
1400	988	0.72	1056	0.83	1119	0.95	1179	1.06	1236	1.18
1450	994	0.75	1061	0.87	1124	0.98	1184	1.10	1241	1.22
1500	1000	0.79	1066	0.90	1129	1.02	1189	1.14	1245	1.26

LEGEND
 Bhp — Brake Horsepower
 Field-Supplied Motor Required

NOTES:
 1. Motor drive range is 482 to 736 rpm for low range motor/drive and 796 to 1128 rpm for high range motor/drive. All other rpms require a field-supplied drive.
 2. Maximum continuous bhp is 0.85 for low range motor/drive and 0.85 for high range motor/drive.
 3. See page 35 for General Fan Performance Notes.

Table 7 — Fan Performance — 48PGE/M04 Vertical Units

AIRFLOW (Cfm)	AVAILABLE EXTERNAL STATIC PRESSURE (in. wg)									
	0.2		0.4		0.6		0.8		1.0	
	Rpm	Bhp	Rpm	Bhp	Rpm	Bhp	Rpm	Bhp	Rpm	Bhp
900	452	0.09	584	0.16	693	0.23	786	0.31	870	0.38
950	460	0.10	590	0.17	698	0.25	791	0.32	874	0.40
1000	469	0.11	597	0.18	703	0.26	796	0.34	878	0.42
1050	479	0.12	604	0.20	709	0.28	801	0.36	883	0.45
1100	488	0.13	611	0.21	715	0.29	806	0.38	888	0.47
1150	498	0.15	619	0.23	721	0.31	812	0.40	893	0.49
1200	509	0.16	627	0.24	728	0.33	817	0.42	898	0.52
1250	519	0.17	635	0.26	735	0.35	823	0.44	903	0.54
1300	530	0.19	643	0.28	742	0.37	829	0.47	909	0.57
1350	542	0.21	652	0.29	749	0.39	836	0.49	915	0.59
1400	553	0.22	661	0.31	756	0.41	842	0.51	921	0.62
1450	565	0.24	670	0.33	764	0.44	849	0.54	927	0.65
1500	577	0.26	680	0.36	772	0.46	856	0.57	933	0.68

AIRFLOW (Cfm)	AVAILABLE EXTERNAL STATIC PRESSURE (in. wg)									
	1.2		1.4		1.6		1.8		2.0	
	Rpm	Bhp	Rpm	Bhp	Rpm	Bhp	Rpm	Bhp	Rpm	Bhp
900	945	0.46	1016	0.55	1081	0.63	1143	0.72	1201	0.81
950	950	0.49	1019	0.57	1085	0.66	1146	0.75	1204	0.84
1000	954	0.51	1023	0.60	1089	0.69	1150	0.78	1208	0.88
1050	958	0.53	1028	0.63	1093	0.72	1154	0.81	1212	0.91
1100	963	0.56	1032	0.65	1097	0.75	1158	0.85	1216	0.95
1150	967	0.59	1036	0.68	1101	0.78	1162	0.88	1220	0.99
1200	972	0.61	1041	0.71	1105	0.81	1166	0.92	1224	1.03
1250	977	0.64	1045	0.74	1110	0.85	1170	0.96	1228	1.06
1300	982	0.67	1050	0.78	1114	0.88	1175	0.99	1232	1.10
1350	987	0.70	1055	0.81	1119	0.92	1179	1.03	1236	1.15
1400	993	0.73	1060	0.84	1124	0.95	1184	1.07	1241	1.19
1450	999	0.76	1066	0.88	1129	0.99	1189	1.11	1245	1.23
1500	1004	0.79	1071	0.91	1134	1.03	1193	1.15	1250	1.28

LEGEND
 Bhp — Brake Horsepower
 Field-Supplied Motor Required

NOTES:
 1. Motor drive range is 482 to 736 rpm for low range motor/drive and 796 to 1128 rpm for high range motor/drive. All other rpms require a field-supplied drive.
 2. Maximum continuous bhp is 0.85 for low range motor/drive and 0.85 for high range motor/drive.
 3. See page 35 for General Fan Performance Notes.

Table 8 — Fan Performance — 48PGF/N04 Vertical Units

AIRFLOW (Cfm)	AVAILABLE EXTERNAL STATIC PRESSURE (in. wg)									
	0.2		0.4		0.6		0.8		1.0	
	Rpm	Bhp	Rpm	Bhp	Rpm	Bhp	Rpm	Bhp	Rpm	Bhp
900	459	0.10	590	0.16	698	0.24	792	0.31	876	0.39
950	468	0.11	597	0.18	704	0.25	797	0.33	881	0.41
1000	477	0.12	604	0.19	710	0.27	802	0.35	885	0.43
1050	488	0.13	611	0.20	716	0.28	807	0.37	890	0.45
1100	498	0.14	619	0.22	722	0.30	813	0.39	895	0.48
1150	509	0.15	627	0.23	729	0.32	819	0.41	900	0.50
1200	520	0.17	636	0.25	736	0.34	825	0.43	906	0.53
1250	531	0.18	644	0.27	743	0.36	831	0.45	911	0.55
1300	543	0.20	653	0.28	751	0.38	838	0.48	917	0.58
1350	555	0.21	663	0.30	759	0.40	845	0.50	923	0.61
1400	567	0.23	672	0.32	767	0.42	852	0.53	930	0.63
1450	579	0.25	682	0.35	775	0.45	859	0.55	936	0.66
1500	592	0.27	692	0.37	784	0.47	867	0.58	943	0.69

AIRFLOW (Cfm)	AVAILABLE EXTERNAL STATIC PRESSURE (in. wg)									
	1.2		1.4		1.6		1.8		2.0	
	Rpm	Bhp	Rpm	Bhp	Rpm	Bhp	Rpm	Bhp	Rpm	Bhp
900	953	0.47	1023	0.56	1089	0.64	1151	0.73	1210	0.82
950	957	0.49	1027	0.58	1093	0.67	1155	0.76	1214	0.86
1000	961	0.52	1031	0.61	1097	0.70	1159	0.80	1217	0.89
1050	965	0.54	1035	0.64	1101	0.73	1162	0.83	1221	0.93
1100	970	0.57	1040	0.67	1105	0.76	1166	0.86	1225	0.97
1150	975	0.60	1044	0.69	1109	0.80	1171	0.90	1229	1.00
1200	980	0.62	1049	0.73	1114	0.83	1175	0.93	1233	1.04
1250	985	0.65	1054	0.76	1118	0.86	1179	0.97	1237	1.08
1300	990	0.68	1059	0.79	1123	0.90	1184	1.01	1241	1.12
1350	996	0.71	1064	0.82	1128	0.93	1188	1.05	1246	1.17
1400	1002	0.74	1069	0.86	1133	0.97	1193	1.09	1250	1.21
1450	1008	0.78	1075	0.89	1138	1.01	1198	1.13	1255	1.25
1500	1014	0.81	1081	0.93	1144	1.05	1203	1.17	1260	1.30

LEGEND

Bhp — Brake Horsepower

Field-Supplied Motor Required

NOTES:

1. Motor drive range is 482 to 736 rpm for low range motor/drive and 796 to 1128 rpm for high range motor drive. All other rpms require a field-supplied drive.
2. Maximum continuous bhp is 0.85 for low range motor/drive and 0.85 for high range motor/drive.
3. See page 35 for General Fan Performance Notes.

Table 9 — Fan Performance — 48PGD/L05 Vertical Units

AIRFLOW (Cfm)	AVAILABLE EXTERNAL STATIC PRESSURE (in. wg)									
	0.2		0.4		0.6		0.8		1.0	
	Rpm	Bhp	Rpm	Bhp	Rpm	Bhp	Rpm	Bhp	Rpm	Bhp
1200	504	0.16	613	0.23	710	0.31	798	0.40	881	0.49
1300	527	0.19	632	0.27	725	0.35	810	0.44	890	0.54
1400	551	0.22	652	0.31	741	0.40	823	0.49	900	0.59
1500	576	0.26	673	0.35	759	0.44	838	0.54	912	0.65
1600	600	0.30	694	0.40	777	0.50	854	0.60	926	0.71
1700	626	0.35	716	0.45	797	0.55	871	0.66	941	0.78
1800	651	0.40	739	0.51	817	0.62	889	0.73	957	0.85
1900	677	0.46	762	0.57	838	0.69	908	0.80	974	0.93
2000	703	0.52	785	0.64	859	0.76	927	0.88	992	1.01

AIRFLOW (Cfm)	AVAILABLE EXTERNAL STATIC PRESSURE (in. wg)									
	1.2		1.4		1.6		1.8		2.0	
	Rpm	Bhp	Rpm	Bhp	Rpm	Bhp	Rpm	Bhp	Rpm	Bhp
1200	957	0.59	1030	0.70	1098	0.80	1163	0.91	1225	1.03
1300	964	0.64	1035	0.75	1102	0.86	1166	0.98	1227	1.10
1400	973	0.70	1042	0.81	1107	0.92	1170	1.04	1231	1.17
1500	983	0.76	1050	0.87	1114	0.99	1176	1.12	1235	1.24
1600	994	0.82	1060	0.94	1122	1.06	1183	1.19	1241	1.32
1700	1007	0.89	1071	1.02	1132	1.14	1191	1.27	1248	1.41
1800	1021	0.97	1083	1.10	1143	1.23	1200	1.36	1256	1.50
1900	1037	1.05	1097	1.18	1155	1.32	1211	1.45	1266	1.60
2000	1053	1.14	1111	1.27	1168	1.41	1223	1.55	1276	1.70

LEGEND

Bhp — Brake Horsepower

High Range Motor/Drive Required

Field-Supplied Motor Required (Single Phase)

NOTES:

1. Motor drive range is 596 to 910 rpm for low range motor/drive and 828 to 1173 rpm for high range motor/drive. All other rpms require a field-supplied drive.
2. Maximum continuous bhp is 0.85 for low range motor/drive and 1.60 (single phase) and 2.40 (3 phase) for high range motor/drive.
3. See page 35 for General Fan Performance Notes.

Table 10 — Fan Performance — 48PGE/M05 Vertical Units

AIRFLOW (Cfm)	AVAILABLE EXTERNAL STATIC PRESSURE (in. wg)									
	0.2		0.4		0.6		0.8		1.0	
	Rpm	Bhp	Rpm	Bhp	Rpm	Bhp	Rpm	Bhp	Rpm	Bhp
1200	509	0.16	618	0.24	714	0.32	802	0.41	884	0.50
1300	533	0.19	637	0.27	730	0.36	814	0.45	894	0.55
1400	557	0.23	658	0.31	746	0.40	828	0.50	905	0.60
1500	582	0.27	679	0.36	764	0.45	843	0.55	917	0.66
1600	608	0.31	701	0.40	783	0.50	860	0.61	931	0.72
1700	634	0.36	723	0.46	803	0.56	877	0.67	947	0.79
1800	660	0.41	747	0.52	824	0.63	896	0.74	963	0.86
1900	686	0.47	770	0.58	846	0.70	915	0.82	981	0.94
2000	713	0.54	795	0.66	868	0.78	935	0.90	999	1.02

AIRFLOW (Cfm)	AVAILABLE EXTERNAL STATIC PRESSURE (in. wg)									
	1.2		1.4		1.6		1.8		2.0	
	Rpm	Bhp	Rpm	Bhp	Rpm	Bhp	Rpm	Bhp	Rpm	Bhp
1200	961	0.60	1033	0.70	1101	0.81	1166	0.92	1228	1.03
1300	968	0.65	1039	0.76	1106	0.87	1169	0.98	1230	1.10
1400	977	0.70	1046	0.82	1111	0.93	1174	1.05	1234	1.17
1500	987	0.77	1054	0.88	1118	1.00	1180	1.12	1239	1.25
1600	999	0.83	1065	0.95	1127	1.07	1187	1.20	1245	1.33
1700	1013	0.90	1076	1.03	1137	1.15	1196	1.28	1253	1.42
1800	1027	0.98	1089	1.11	1148	1.24	1206	1.37	1261	1.51
1900	1043	1.06	1103	1.20	1161	1.33	1217	1.47	1271	1.61
2000	1060	1.16	1118	1.29	1175	1.43	1229	1.57	1282	1.72

LEGEND
Bhp — Brake Horsepower
 High Range Motor/Drive Required
 Field-Supplied Motor Required (Single Phase)

NOTES:
 1. Motor drive range is 596 to 910 rpm for low range motor/drive and 828 to 1173 rpm for high range motor/drive. All other rpms require a field-supplied drive.
 2. Maximum continuous bhp is 0.85 for low range motor/drive and 1.60 (single phase) and 2.40 (3 phase) for high range motor/drive.
 3. See page 35 for General Fan Performance Notes.

Table 11 — Fan Performance — 48PGF/N05 Vertical Units

AIRFLOW (Cfm)	AVAILABLE EXTERNAL STATIC PRESSURE (in. wg)									
	0.2		0.4		0.6		0.8		1.0	
	Rpm	Bhp	Rpm	Bhp	Rpm	Bhp	Rpm	Bhp	Rpm	Bhp
1200	520	0.17	628	0.24	723	0.33	811	0.41	892	0.51
1300	545	0.20	648	0.28	739	0.37	823	0.46	902	0.56
1400	570	0.24	668	0.32	756	0.41	837	0.51	913	0.61
1500	596	0.28	691	0.37	775	0.46	853	0.56	927	0.67
1600	623	0.32	714	0.42	795	0.52	870	0.62	942	0.73
1700	650	0.37	737	0.48	816	0.58	889	0.69	958	0.80
1800	677	0.43	762	0.54	838	0.65	909	0.76	976	0.88
1900	705	0.50	787	0.61	861	0.72	929	0.84	994	0.97
2000	734	0.57	813	0.68	884	0.80	951	0.93	1014	1.06

AIRFLOW (Cfm)	AVAILABLE EXTERNAL STATIC PRESSURE (in. wg)									
	1.2		1.4		1.6		1.8		2.0	
	Rpm	Bhp	Rpm	Bhp	Rpm	Bhp	Rpm	Bhp	Rpm	Bhp
1200	968	0.61	1040	0.71	1108	0.82	1172	0.93	1233	1.04
1300	976	0.66	1046	0.77	1112	0.88	1176	1.00	1237	1.11
1400	985	0.72	1054	0.83	1119	0.95	1181	1.07	1241	1.19
1500	996	0.78	1063	0.90	1127	1.02	1188	1.14	1247	1.27
1600	1009	0.85	1074	0.97	1136	1.09	1196	1.22	1254	1.35
1700	1024	0.92	1087	1.05	1147	1.17	1205	1.31	1262	1.44
1800	1039	1.00	1100	1.13	1159	1.26	1216	1.40	1272	1.54
1900	1056	1.09	1116	1.22	1173	1.36	1229	1.50	1283	1.64
2000	1074	1.19	1132	1.32	1188	1.46	1242	1.61	1295	1.75

LEGEND
Bhp — Brake Horsepower
 High Range Motor/Drive Required
 Field-Supplied Motor Required (Single Phase)

NOTES:
 1. Motor drive range is 596 to 910 rpm for low range motor/drive and 828 to 1173 rpm for high range motor/drive. All other rpms require a field-supplied drive.
 2. Maximum continuous bhp is 0.85 for low range motor/drive and 1.60 (single phase) and 2.40 (3 phase) for high range motor/drive.
 3. See page 35 for General Fan Performance Notes.

Table 12 — Fan Performance — 48PGD/L06 Vertical Units

AIRFLOW (Cfm)	AVAILABLE EXTERNAL STATIC PRESSURE (in. wg)									
	0.2		0.4		0.6		0.8		1.0	
	Rpm	Bhp	Rpm	Bhp	Rpm	Bhp	Rpm	Bhp	Rpm	Bhp
1500	593	0.27	688	0.37	773	0.46	851	0.56	925	0.67
1600	620	0.32	711	0.42	793	0.52	868	0.62	939	0.73
1700	646	0.37	734	0.47	813	0.58	886	0.69	955	0.80
1800	673	0.43	758	0.53	835	0.64	905	0.76	972	0.88
1900	700	0.49	783	0.60	857	0.72	925	0.84	990	0.96
2000	728	0.56	807	0.68	879	0.80	946	0.92	1009	1.05
2100	755	0.63	833	0.76	903	0.88	968	1.01	1029	1.14
2200	783	0.71	858	0.84	926	0.97	990	1.11	1050	1.24
2300	811	0.80	884	0.94	950	1.07	1012	1.21	1071	1.35
2400	840	0.90	910	1.04	975	1.18	1035	1.33	1092	1.47
2500	868	1.00	937	1.15	1000	1.30	1059	1.45	1115	1.60

AIRFLOW (Cfm)	AVAILABLE EXTERNAL STATIC PRESSURE (in. wg)									
	1.2		1.4		1.6		1.8		2.0	
	Rpm	Bhp	Rpm	Bhp	Rpm	Bhp	Rpm	Bhp	Rpm	Bhp
1500	995	0.78	1061	0.89	1125	1.01	1186	1.14	1245	1.26
1600	1007	0.85	1072	0.96	1134	1.09	1194	1.22	1252	1.35
1700	1021	0.92	1084	1.04	1145	1.17	1203	1.30	1260	1.44
1800	1036	1.00	1098	1.13	1157	1.26	1214	1.39	1269	1.53
1900	1053	1.08	1112	1.22	1170	1.35	1226	1.49	1280	1.63
2000	1070	1.18	1128	1.31	1184	1.45	1238	1.60	1291	1.74
2100	1088	1.28	1145	1.42	1199	1.56	1253	1.71	1304	1.86
2200	1107	1.38	1162	1.53	1216	1.68	1268	1.83	1318	1.98
2300	1127	1.50	1181	1.65	1233	1.80	1284	1.95	1333	2.11
2400	1147	1.62	1200	1.77	1251	1.93	1300	2.09	1349	2.25
2500	1168	1.75	1220	1.91	1270	2.07	1318	2.23	1365	2.40

LEGEND

Bhp — Brake Horsepower
 — Field-Supplied Motor Required (Single Phase)

NOTES:

1. Motor drive range is 690 to 978 rpm for low range motor/drive and 929 to 1261 rpm for high range motor/drive. All other rpms require a field-supplied drive.
2. Maximum continuous bhp is 0.85 (single phase) and 2.40 (3 phase) for low range motor/drive and 1.60 (single phase) and 2.40 (3 phase) for high range motor/drive.
3. See page 35 for General Fan Performance Notes.

Table 13 — Fan Performance — 48PGE/M06 Vertical Units

AIRFLOW (Cfm)	AVAILABLE EXTERNAL STATIC PRESSURE (in. wg)									
	0.2		0.4		0.6		0.8		1.0	
	Rpm	Bhp	Rpm	Bhp	Rpm	Bhp	Rpm	Bhp	Rpm	Bhp
1500	607	0.29	700	0.38	784	0.47	861	0.57	934	0.68
1600	634	0.33	724	0.43	804	0.53	879	0.64	950	0.75
1700	662	0.39	748	0.49	826	0.60	898	0.71	967	0.82
1800	690	0.45	773	0.55	848	0.67	918	0.78	985	0.90
1900	719	0.51	799	0.63	872	0.74	940	0.86	1004	0.98
2000	748	0.59	825	0.70	896	0.83	962	0.95	1024	1.08
2100	777	0.67	852	0.79	920	0.92	985	1.05	1045	1.18
2200	807	0.75	879	0.88	946	1.01	1008	1.15	1067	1.29
2300	837	0.85	907	0.98	971	1.12	1032	1.26	1090	1.40
2400	867	0.95	935	1.09	998	1.24	1057	1.38	1113	1.53
2500	897	1.06	963	1.21	1024	1.36	1082	1.51	1137	1.66

AIRFLOW (Cfm)	AVAILABLE EXTERNAL STATIC PRESSURE (in. wg)									
	1.2		1.4		1.6		1.8		2.0	
	Rpm	Bhp	Rpm	Bhp	Rpm	Bhp	Rpm	Bhp	Rpm	Bhp
1500	1004	0.79	1070	0.91	1133	1.03	1194	1.15	1253	1.28
1600	1017	0.86	1081	0.98	1143	1.11	1203	1.24	1260	1.37
1700	1032	0.94	1094	1.06	1155	1.19	1213	1.32	1269	1.46
1800	1048	1.02	1109	1.15	1168	1.28	1224	1.42	1279	1.56
1900	1066	1.11	1125	1.24	1182	1.38	1237	1.52	1291	1.66
2000	1084	1.21	1142	1.35	1197	1.49	1251	1.63	1304	1.78
2100	1104	1.31	1160	1.45	1214	1.60	1267	1.75	1318	1.90
2200	1124	1.43	1179	1.57	1231	1.72	1283	1.87	1333	2.03
2300	1145	1.55	1198	1.70	1250	1.85	1300	2.01	1349	2.17
2400	1167	1.68	1219	1.83	1269	1.99	1318	2.15	1366	2.31
2500	1189	1.82	1240	1.97	1290	2.14	1337	2.30	—	—

LEGEND

Bhp — Brake Horsepower
 — Field-Supplied Motor Required (Single Phase)

NOTES:

1. Motor drive range is 690 to 978 rpm for low range motor/drive and 929 to 1261 rpm for high range motor/drive. All other rpms require a field-supplied drive.
2. Maximum continuous bhp is 0.85 (single phase) and 2.40 (3 phase) for low range motor/drive and 1.60 (single phase) and 2.40 (3 phase) for high range motor/drive.
3. See page 35 for General Fan Performance Notes.

Table 14 — Fan Performance — 48PGF/N06 Vertical Units

AIRFLOW (Cfm)	AVAILABLE EXTERNAL STATIC PRESSURE (in. wg)									
	0.2		0.4		0.6		0.8		1.0	
	Rpm	Bhp	Rpm	Bhp	Rpm	Bhp	Rpm	Bhp	Rpm	Bhp
1500	620	0.30	711	0.39	794	0.49	871	0.59	944	0.70
1600	648	0.35	736	0.45	816	0.55	890	0.65	960	0.76
1700	677	0.40	762	0.51	838	0.61	910	0.72	978	0.84
1800	707	0.47	788	0.58	862	0.69	931	0.80	997	0.92
1900	737	0.54	815	0.65	887	0.77	954	0.89	1017	1.01
2000	767	0.61	843	0.73	912	0.85	977	0.98	1039	1.11
2100	798	0.70	871	0.82	938	0.95	1001	1.08	1061	1.21
2200	829	0.79	900	0.92	965	1.05	1026	1.19	1084	1.33
2300	861	0.89	929	1.03	992	1.17	1052	1.31	1108	1.45
2400	893	1.00	959	1.15	1020	1.29	1078	1.43	1133	1.58
2500	925	1.12	989	1.27	1048	1.42	1105	1.57	1158	1.72

AIRFLOW (CFM)	AVAILABLE EXTERNAL STATIC PRESSURE (in. wg)									
	1.2		1.4		1.6		1.8		2.0	
	Rpm	Bhp	Rpm	Bhp	Rpm	Bhp	Rpm	Bhp	Rpm	Bhp
1500	1013	0.81	1078	0.92	1141	1.05	1202	1.17	1260	1.30
1600	1027	0.88	1091	1.00	1152	1.13	1211	1.25	1269	1.39
1700	1043	0.96	1105	1.08	1165	1.21	1222	1.35	1278	1.48
1800	1060	1.05	1120	1.18	1179	1.31	1235	1.44	1290	1.59
1900	1078	1.14	1137	1.27	1194	1.41	1249	1.55	1302	1.70
2000	1098	1.24	1155	1.38	1210	1.52	1264	1.67	1316	1.81
2100	1119	1.35	1174	1.49	1228	1.64	1280	1.79	1331	1.94
2200	1140	1.47	1195	1.62	1247	1.77	1298	1.92	1348	2.08
2300	1163	1.60	1216	1.75	1267	1.90	1317	2.06	1365	2.22
2400	1186	1.73	1238	1.89	1288	2.05	1336	2.21	1384	2.37
2500	1210	1.88	1261	2.04	1309	2.20	1357	2.37	—	—

LEGEND
Bhp — Brake Horsepower
— Field-Supplied Motor Required (Single Phase)

NOTES:
 1. Motor drive range is 690 to 978 rpm for low range motor/drive and 929 to 1261 rpm for high range motor/drive. All other rpms require a field-supplied drive.
 2. Maximum continuous bhp is 0.85 (single phase) and 2.40 (3 phase) for low range motor/drive and 1.60 (single phase) and 2.40 (3 phase) for high range motor/drive.
 3. See page 35 for General Fan Performance Notes.

Table 15 — Fan Performance — 48PGD/L07 Vertical Units

AIRFLOW (Cfm)	AVAILABLE EXTERNAL STATIC PRESSURE (in. wg)									
	0.2		0.4		0.6		0.8		1.0	
	Rpm	Bhp	Rpm	Bhp	Rpm	Bhp	Rpm	Bhp	Rpm	Bhp
1800	686	0.44	769	0.55	845	0.66	915	0.77	982	0.89
1900	714	0.51	794	0.62	868	0.73	936	0.85	1000	0.98
2000	742	0.58	820	0.70	891	0.82	957	0.94	1020	1.07
2100	770	0.66	846	0.78	915	0.91	979	1.03	1040	1.17
2200	799	0.74	872	0.87	939	1.00	1002	1.13	1061	1.27
2300	828	0.83	899	0.97	964	1.10	1025	1.24	1083	1.39
2400	856	0.93	926	1.07	989	1.22	1049	1.36	1105	1.51
2500	886	1.04	953	1.19	1015	1.33	1073	1.48	1128	1.64
2600	915	1.15	980	1.31	1040	1.46	1097	1.62	1151	1.77
2700	944	1.28	1008	1.44	1067	1.60	1122	1.76	1175	1.92
2800	974	1.41	1035	1.58	1093	1.74	1147	1.91	1199	2.08
2900	1003	1.55	1063	1.72	1120	1.90	1173	2.07	1223	2.24
3000	1033	1.70	1092	1.88	1146	2.06	1198	2.24	—	—

AIRFLOW (Cfm)	AVAILABLE EXTERNAL STATIC PRESSURE (in. wg)									
	1.2		1.4		1.6		1.8		2.0	
	Rpm	Bhp	Rpm	Bhp	Rpm	Bhp	Rpm	Bhp	Rpm	Bhp
1800	1045	1.02	1106	1.14	1165	1.28	1222	1.41	1277	1.55
1900	1062	1.10	1121	1.24	1179	1.37	1234	1.51	1288	1.66
2000	1080	1.20	1138	1.34	1193	1.48	1247	1.62	1300	1.77
2100	1099	1.30	1155	1.44	1209	1.59	1262	1.73	1313	1.89
2200	1118	1.41	1173	1.56	1226	1.71	1278	1.86	1328	2.01
2300	1138	1.53	1192	1.68	1244	1.83	1294	1.99	1343	2.15
2400	1159	1.66	1212	1.81	1262	1.97	1312	2.13	1360	2.29
2500	1181	1.79	1232	1.95	1282	2.11	1330	2.27	—	—
2600	1203	1.93	1253	2.10	1301	2.26	—	—	—	—
2700	1226	2.08	1275	2.25	—	—	—	—	—	—
2800	1249	2.25	—	—	—	—	—	—	—	—
2900	—	—	—	—	—	—	—	—	—	—
3000	—	—	—	—	—	—	—	—	—	—

LEGEND
Bhp — Brake Horsepower

NOTES:
 1. Motor drive range is 796 to 1128 rpm for low range motor/drive and 1150 to 1438 rpm for high range motor/drive. All other rpms require a field-supplied drive.
 2. Maximum continuous bhp is 2.40 for low range motor/drive and 3.10 for high range motor/drive.
 3. See page 35 for General Fan Performance Notes.

Table 16 — Fan Performance — 48PGE/M07 Vertical Units

AIRFLOW (Cfm)	AVAILABLE EXTERNAL STATIC PRESSURE (in. wg)									
	0.2		0.4		0.6		0.8		1.0	
	Rpm	Bhp	Rpm	Bhp	Rpm	Bhp	Rpm	Bhp	Rpm	Bhp
1800	703	0.46	784	0.57	859	0.68	928	0.80	994	0.92
1900	732	0.53	811	0.64	882	0.76	950	0.88	1014	1.00
2000	761	0.61	838	0.72	907	0.85	972	0.97	1034	1.10
2100	791	0.69	865	0.81	932	0.94	996	1.07	1056	1.20
2200	822	0.78	893	0.91	958	1.04	1020	1.18	1079	1.31
2300	852	0.88	921	1.01	985	1.15	1045	1.29	1102	1.43
2400	883	0.98	950	1.13	1011	1.27	1070	1.41	1125	1.56
2500	914	1.10	978	1.25	1039	1.39	1096	1.55	1150	1.70
2600	945	1.22	1008	1.38	1066	1.53	1122	1.69	1175	1.84
2700	976	1.36	1037	1.52	1094	1.68	1148	1.84	1200	2.00
2800	1007	1.50	1067	1.67	1122	1.83	1175	2.00	1226	2.17
2900	1039	1.65	1097	1.82	1151	2.00	1203	2.17	1252	2.34
3000	1071	1.82	1127	2.00	1180	2.17	1230	2.35	—	—

AIRFLOW (Cfm)	AVAILABLE EXTERNAL STATIC PRESSURE (in. wg)									
	1.2		1.4		1.6		1.8		2.0	
	Rpm	Bhp	Rpm	Bhp	Rpm	Bhp	Rpm	Bhp	Rpm	Bhp
1800	1057	1.04	1117	1.17	1176	1.30	1232	1.44	1287	1.58
1900	1075	1.13	1134	1.27	1191	1.40	1246	1.54	1299	1.69
2000	1094	1.23	1151	1.37	1207	1.51	1260	1.65	1312	1.80
2100	1114	1.34	1170	1.48	1224	1.63	1276	1.77	1327	1.93
2200	1135	1.46	1189	1.60	1242	1.75	1293	1.90	1343	2.06
2300	1157	1.58	1209	1.73	1261	1.88	1311	2.04	1359	2.20
2400	1179	1.71	1231	1.87	1281	2.02	1329	2.19	1377	2.35
2500	1202	1.85	1252	2.01	1301	2.18	1349	2.34	—	—
2600	1226	2.01	1275	2.17	1323	2.34	—	—	—	—
2700	1250	2.17	1298	2.34	—	—	—	—	—	—
2800	1275	2.34	—	—	—	—	—	—	—	—
2900	—	—	—	—	—	—	—	—	—	—
3000	—	—	—	—	—	—	—	—	—	—

LEGEND
Bhp — Brake Horsepower

- NOTES:
1. Motor drive range is 796 to 1128 rpm for low range motor/drive and 1150 to 1438 rpm for high range motor/drive. All other rpms require a field-supplied drive.
 2. Maximum continuous bhp is 2.40 for low range motor/drive and 3.10 for high range motor/drive.
 3. See page 35 for General Fan Performance Notes.

Table 17 — Fan Performance — 48PGF/N07 Vertical Units

AIRFLOW (Cfm)	AVAILABLE EXTERNAL STATIC PRESSURE (in. wg)									
	0.2		0.4		0.6		0.8		1.0	
	Rpm	Bhp	Rpm	Bhp	Rpm	Bhp	Rpm	Bhp	Rpm	Bhp
1800	719	0.48	799	0.59	872	0.70	941	0.82	1006	0.94
1900	749	0.55	826	0.67	897	0.79	964	0.91	1027	1.03
2000	780	0.63	855	0.75	923	0.88	988	1.00	1049	1.13
2100	812	0.72	884	0.85	950	0.97	1012	1.10	1072	1.24
2200	844	0.82	913	0.95	977	1.08	1038	1.22	1096	1.36
2300	876	0.92	943	1.06	1005	1.20	1064	1.34	1120	1.48
2400	908	1.04	973	1.18	1033	1.32	1091	1.47	1145	1.62
2500	941	1.16	1003	1.31	1062	1.46	1118	1.61	1171	1.76
2600	974	1.29	1034	1.45	1092	1.60	1146	1.76	1198	1.92
2700	1007	1.43	1066	1.59	1121	1.76	1174	1.92	1225	2.08
2800	1040	1.59	1097	1.75	1151	1.92	1203	2.09	1252	2.26
2900	1073	1.75	1129	1.93	1181	2.10	1232	2.27	—	—
3000	1107	1.93	1161	2.11	1212	2.29	—	—	—	—

AIRFLOW (Cfm)	AVAILABLE EXTERNAL STATIC PRESSURE (in. wg)									
	1.2		1.4		1.6		1.8		2.0	
	Rpm	Bhp	Rpm	Bhp	Rpm	Bhp	Rpm	Bhp	Rpm	Bhp
1800	1069	1.06	1129	1.19	1187	1.33	1243	1.46	1297	1.61
1900	1088	1.16	1146	1.29	1202	1.43	1257	1.57	1310	1.72
2000	1108	1.26	1165	1.40	1220	1.54	1273	1.69	1325	1.84
2100	1129	1.38	1184	1.52	1238	1.67	1290	1.82	1340	1.97
2200	1151	1.50	1205	1.65	1257	1.80	1308	1.95	1357	2.11
2300	1174	1.63	1227	1.78	1278	1.93	1327	2.09	1375	2.25
2400	1198	1.77	1249	1.92	1299	2.08	1347	2.25	—	—
2500	1223	1.92	1273	2.08	1321	2.24	—	—	—	—
2600	1248	2.08	1297	2.24	—	—	—	—	—	—
2700	1274	2.25	—	—	—	—	—	—	—	—
2800	—	—	—	—	—	—	—	—	—	—
2900	—	—	—	—	—	—	—	—	—	—
3000	—	—	—	—	—	—	—	—	—	—

LEGEND
Bhp — Brake Horsepower

- NOTES:
1. Motor drive range is 796 to 1128 rpm for low range motor/drive and 1150 to 1438 rpm for high range motor/drive. All other rpms require a field-supplied drive.
 2. Maximum continuous bhp is 2.40 for low range motor/drive and 3.10 for high range motor/drive.
 3. See page 35 for General Fan Performance Notes.

Table 18 — Fan Performance — 48PGF/N03 Horizontal Units

AIRFLOW (Cfm)	AVAILABLE EXTERNAL STATIC PRESSURE (in. wg)									
	0.2		0.4		0.6		0.8		1.0	
	Rpm	Bhp	Rpm	Bhp	Rpm	Bhp	Rpm	Bhp	Rpm	Bhp
600	387	0.05	529	0.09	641	0.14	736	0.20	821	0.25
650	391	0.05	532	0.10	643	0.15	738	0.21	822	0.27
700	397	0.06	535	0.11	646	0.16	741	0.22	824	0.28
750	402	0.06	539	0.12	649	0.17	743	0.23	826	0.30
800	408	0.07	543	0.12	652	0.18	745	0.25	829	0.31
850	415	0.08	547	0.13	655	0.20	748	0.26	831	0.33
900	422	0.08	552	0.14	659	0.21	751	0.28	834	0.35
950	430	0.09	557	0.15	662	0.22	754	0.29	837	0.37
1000	437	0.10	562	0.16	666	0.23	758	0.31	839	0.38

AIRFLOW (Cfm)	AVAILABLE EXTERNAL STATIC PRESSURE (in. wg)									
	1.2		1.4		1.6		1.8		2.0	
	Rpm	Bhp	Rpm	Bhp	Rpm	Bhp	Rpm	Bhp	Rpm	Bhp
600	897	0.31	967	0.38	1032	0.45	1094	0.51	1152	0.59
650	899	0.33	969	0.40	1034	0.47	1096	0.54	1154	0.61
700	900	0.35	970	0.42	1036	0.49	1097	0.56	1155	0.64
750	902	0.37	972	0.44	1038	0.51	1099	0.59	1157	0.66
800	904	0.38	974	0.46	1039	0.53	1101	0.61	1159	0.69
850	907	0.40	976	0.48	1041	0.56	1102	0.64	1160	0.72
900	909	0.42	978	0.50	1043	0.58	1104	0.66	1162	0.75
950	911	0.44	981	0.52	1045	0.61	1106	0.69	1164	0.78
1000	914	0.46	983	0.55	1048	0.63	1109	0.72	1166	0.81

LEGEND

Bhp — Brake Horsepower

NOTES:

1. Motor drive range is 482 to 736 rpm for low range motor/drive and 656 to 1001 rpm for high range motor/drive. All other rpms require a field-supplied drive.
2. Maximum continuous bhp is 0.85 for low range motor/drive and 0.85 for high range motor/drive motors.
3. See page 35 for General Fan Performance Notes.

Table 19 — Fan Performance — 48PGD/L04 Horizontal Units

AIRFLOW (Cfm)	AVAILABLE EXTERNAL STATIC PRESSURE (in. wg)									
	0.2		0.4		0.6		0.8		1.0	
	Rpm	Bhp	Rpm	Bhp	Rpm	Bhp	Rpm	Bhp	Rpm	Bhp
900	422	0.08	552	0.14	659	0.21	751	0.28	834	0.35
950	430	0.09	557	0.15	662	0.22	754	0.29	837	0.37
1000	437	0.10	562	0.16	666	0.23	758	0.31	839	0.38
1050	446	0.11	568	0.17	671	0.25	761	0.32	843	0.40
1100	454	0.12	573	0.19	675	0.26	765	0.34	846	0.42
1150	463	0.13	580	0.20	680	0.28	769	0.36	849	0.44
1200	473	0.14	586	0.21	685	0.29	773	0.37	853	0.46
1250	482	0.15	593	0.23	691	0.31	778	0.39	857	0.48
1300	492	0.16	601	0.24	697	0.32	783	0.41	861	0.50
1350	503	0.18	608	0.26	703	0.34	788	0.43	865	0.53
1400	513	0.19	616	0.27	709	0.36	793	0.45	870	0.55
1450	524	0.21	624	0.29	716	0.38	799	0.48	875	0.58
1500	535	0.23	633	0.31	722	0.40	804	0.50	880	0.60

AIRFLOW (Cfm)	AVAILABLE EXTERNAL STATIC PRESSURE (in. wg)									
	1.2		1.4		1.6		1.8		2.0	
	Rpm	Bhp	Rpm	Bhp	Rpm	Bhp	Rpm	Bhp	Rpm	Bhp
900	909	0.42	978	0.50	1043	0.58	1104	0.66	1162	0.75
950	911	0.44	981	0.52	1045	0.61	1106	0.69	1164	0.78
1000	914	0.46	983	0.55	1048	0.63	1109	0.72	1166	0.81
1050	917	0.48	986	0.57	1050	0.66	1111	0.75	1168	0.84
1100	920	0.51	988	0.59	1053	0.68	1113	0.78	1171	0.87
1150	923	0.53	991	0.62	1055	0.71	1116	0.81	1173	0.90
1200	926	0.55	994	0.64	1058	0.74	1118	0.84	1175	0.94
1250	930	0.58	997	0.67	1061	0.77	1121	0.87	1178	0.97
1300	933	0.60	1001	0.70	1064	0.80	1124	0.90	1181	1.00
1350	937	0.63	1004	0.73	1067	0.83	1127	0.93	1183	1.04
1400	941	0.65	1008	0.75	1070	0.86	1130	0.97	1186	1.08
1450	945	0.68	1012	0.78	1074	0.89	1133	1.00	1189	1.11
1500	950	0.71	1016	0.81	1078	0.92	1136	1.04	1192	1.15

LEGEND

Bhp — Brake Horsepower
 Field-Supplied Motor Required

NOTES:

1. Motor drive range is 482 to 736 rpm for low range motor/drive and 796 to 1128 rpm for high range motor/drive. All other rpms require a field-supplied drive.
2. Maximum continuous bhp is 0.85 for low range motor/drive and 0.85 for high range motor/drive.
3. See page 35 for General Fan Performance Notes.

Table 20 — Fan Performance — 48PGE/M04 Horizontal Units

AIRFLOW (Cfm)	AVAILABLE EXTERNAL STATIC PRESSURE (in. wg)									
	0.2		0.4		0.6		0.8		1.0	
	Rpm	Bhp	Rpm	Bhp	Rpm	Bhp	Rpm	Bhp	Rpm	Bhp
900	425	0.08	554	0.14	661	0.21	754	0.28	837	0.35
950	433	0.09	560	0.15	665	0.22	757	0.29	840	0.37
1000	442	0.10	565	0.16	669	0.24	761	0.31	843	0.39
1050	450	0.11	571	0.18	674	0.25	764	0.33	846	0.41
1100	459	0.12	577	0.19	679	0.26	768	0.34	849	0.43
1150	469	0.13	584	0.20	684	0.28	773	0.36	853	0.45
1200	478	0.14	591	0.22	689	0.29	777	0.38	857	0.47
1250	488	0.16	598	0.23	695	0.31	782	0.40	861	0.49
1300	498	0.17	606	0.25	701	0.33	787	0.42	865	0.51
1350	509	0.18	614	0.26	707	0.35	792	0.44	870	0.53
1400	520	0.20	622	0.28	714	0.37	798	0.46	874	0.56
1450	531	0.21	630	0.30	721	0.39	803	0.48	879	0.58
1500	542	0.23	639	0.32	728	0.41	809	0.51	885	0.61

AIRFLOW (Cfm)	AVAILABLE EXTERNAL STATIC PRESSURE (in. wg)									
	1.2		1.4		1.6		1.8		2.0	
	Rpm	Bhp	Rpm	Bhp	Rpm	Bhp	Rpm	Bhp	Rpm	Bhp
900	912	0.43	982	0.50	1047	0.59	1108	0.67	1167	0.75
950	915	0.45	984	0.53	1049	0.61	1110	0.70	1168	0.78
1000	917	0.47	987	0.55	1051	0.64	1113	0.72	1170	0.81
1050	920	0.49	989	0.57	1054	0.66	1115	0.75	1173	0.85
1100	923	0.51	992	0.60	1056	0.69	1117	0.78	1175	0.88
1150	926	0.53	995	0.62	1059	0.72	1120	0.81	1177	0.91
1200	930	0.56	998	0.65	1062	0.75	1122	0.84	1179	0.94
1250	933	0.58	1001	0.68	1065	0.77	1125	0.87	1182	0.98
1300	937	0.61	1005	0.70	1068	0.80	1128	0.91	1185	1.01
1350	941	0.63	1008	0.73	1071	0.83	1131	0.94	1188	1.05
1400	945	0.66	1012	0.76	1075	0.87	1134	0.97	1191	1.08
1450	950	0.68	1016	0.79	1078	0.90	1137	1.01	1194	1.12
1500	955	0.71	1020	0.82	1082	0.93	1141	1.04	1197	1.16

LEGEND

Bhp — Brake Horsepower

Field-Supplied Motor Required

NOTES:

1. Motor drive range is 482 to 736 rpm for low range motor/drive and 796 to 1128 rpm for high range motor/drive. All other rpms require a field-supplied drive.
2. Maximum continuous bhp is 0.85 for low range motor/drive and 0.85 for high range motor/drive.
3. See page 35 for General Fan Performance Notes.

Table 21 — Fan Performance — 48PGF/N04 Horizontal Units

AIRFLOW (Cfm)	AVAILABLE EXTERNAL STATIC PRESSURE (in. wg)									
	0.2		0.4		0.6		0.8		1.0	
	Rpm	Bhp	Rpm	Bhp	Rpm	Bhp	Rpm	Bhp	Rpm	Bhp
900	432	0.09	560	0.15	667	0.21	760	0.28	843	0.36
950	441	0.09	566	0.16	671	0.23	763	0.30	846	0.37
1000	450	0.10	572	0.17	676	0.24	767	0.31	849	0.39
1050	459	0.11	578	0.18	680	0.25	771	0.33	852	0.41
1100	468	0.12	585	0.19	686	0.27	775	0.35	856	0.43
1150	478	0.14	592	0.21	691	0.28	780	0.37	860	0.45
1200	489	0.15	600	0.22	697	0.30	784	0.39	864	0.47
1250	499	0.16	608	0.24	703	0.32	790	0.41	868	0.50
1300	510	0.18	616	0.25	710	0.34	795	0.43	873	0.52
1350	521	0.19	624	0.27	717	0.36	801	0.45	878	0.54
1400	533	0.21	633	0.29	724	0.38	807	0.47	883	0.57
1450	545	0.23	642	0.31	731	0.40	813	0.49	888	0.59
1500	556	0.24	652	0.33	739	0.42	819	0.52	894	0.62

AIRFLOW (Cfm)	AVAILABLE EXTERNAL STATIC PRESSURE (in. wg)									
	1.2		1.4		1.6		1.8		2.0	
	Rpm	Bhp	Rpm	Bhp	Rpm	Bhp	Rpm	Bhp	Rpm	Bhp
900	919	0.43	989	0.51	1055	0.60	1117	0.68	1175	0.77
950	921	0.45	991	0.54	1057	0.62	1119	0.71	1177	0.80
1000	924	0.48	994	0.56	1059	0.65	1121	0.74	1179	0.83
1050	927	0.50	996	0.58	1061	0.67	1123	0.77	1181	0.86
1100	930	0.52	999	0.61	1064	0.70	1125	0.80	1183	0.89
1150	934	0.54	1002	0.63	1067	0.73	1128	0.83	1185	0.92
1200	937	0.57	1005	0.66	1070	0.76	1130	0.86	1188	0.96
1250	941	0.59	1009	0.69	1073	0.79	1133	0.89	1191	0.99
1300	945	0.62	1013	0.72	1076	0.82	1136	0.92	1193	1.03
1350	949	0.64	1016	0.74	1080	0.85	1139	0.96	1196	1.06
1400	954	0.67	1020	0.77	1083	0.88	1143	0.99	1199	1.10
1450	959	0.70	1025	0.80	1087	0.91	1146	1.03	1203	1.14
1500	964	0.73	1029	0.84	1091	0.95	1150	1.06	1206	1.18

LEGEND

Bhp — Brake Horsepower

Field-Supplied Motor Required

NOTES:

1. Motor drive range is 482 to 736 rpm for low range motor/drive and 796 to 1128 rpm for high range motor/drive. All other rpms require a field-supplied drive.
2. Maximum continuous bhp is 0.85 for low range motor/drive and 0.85 for high range motor/drive.
3. See page 35 for General Fan Performance Notes.

Table 22 — Fan Performance — 48PGD/L05 Horizontal Units

AIRFLOW (Cfm)	AVAILABLE EXTERNAL STATIC PRESSURE (in. wg)									
	0.2		0.4		0.6		0.8		1.0	
	Rpm	Bhp	Rpm	Bhp	Rpm	Bhp	Rpm	Bhp	Rpm	Bhp
1200	436	0.12	559	0.19	661	0.27	753	0.35	839	0.45
1300	456	0.14	574	0.22	673	0.30	762	0.39	845	0.49
1400	477	0.17	592	0.25	687	0.34	774	0.43	853	0.53
1500	500	0.20	611	0.29	703	0.38	787	0.48	864	0.58
1600	523	0.24	631	0.33	721	0.43	801	0.53	877	0.63
1700	548	0.28	652	0.38	739	0.48	818	0.58	891	0.69
1800	573	0.32	674	0.43	759	0.54	835	0.64	906	0.76
1900	600	0.37	697	0.48	779	0.60	854	0.71	923	0.83
2000	627	0.43	720	0.55	801	0.67	873	0.79	941	0.91

AIRFLOW (Cfm)	AVAILABLE EXTERNAL STATIC PRESSURE (in. wg)									
	1.2		1.4		1.6		1.8		2.0	
	Rpm	Bhp	Rpm	Bhp	Rpm	Bhp	Rpm	Bhp	Rpm	Bhp
1200	918	0.54	993	0.64	1063	0.75	1130	0.86	1193	0.97
1300	922	0.58	995	0.69	1064	0.80	1130	0.91	1193	1.03
1400	929	0.63	1000	0.74	1067	0.85	1132	0.97	1194	1.09
1500	937	0.69	1006	0.80	1072	0.91	1136	1.03	1196	1.16
1600	947	0.74	1015	0.86	1079	0.98	1141	1.10	1201	1.23
1700	959	0.81	1025	0.93	1088	1.05	1148	1.18	1207	1.31
1800	973	0.88	1037	1.00	1098	1.13	1157	1.26	1214	1.39
1900	988	0.95	1050	1.08	1110	1.21	1168	1.35	1223	1.48
2000	1004	1.04	1065	1.17	1123	1.30	1179	1.44	1234	1.58

LEGEND

Bhp — Brake Horsepower
 High Range Motor/Drive Required

NOTES:

1. Motor drive range is 596 to 910 rpm for low range motor/drive and 828 to 1173 rpm for high range motor/drive. All other rpms require a field-supplied drive.
2. Maximum continuous bhp is 0.85 for low range motor/drive and 1.60 (single phase) and 2.40 (3 phase) for high range motor/drive.
3. See page 35 for General Fan Performance Notes.

Table 23 — Fan Performance — 48PGE/M05 Horizontal Units

AIRFLOW (Cfm)	AVAILABLE EXTERNAL STATIC PRESSURE (in. wg)									
	0.2		0.4		0.6		0.8		1.0	
	Rpm	Bhp	Rpm	Bhp	Rpm	Bhp	Rpm	Bhp	Rpm	Bhp
1200	443	0.12	564	0.20	666	0.27	758	0.36	842	0.45
1300	463	0.15	580	0.22	678	0.31	767	0.40	849	0.49
1400	485	0.17	598	0.26	693	0.34	778	0.44	858	0.54
1500	508	0.21	617	0.30	709	0.39	792	0.48	869	0.59
1600	532	0.24	638	0.34	727	0.43	807	0.54	882	0.64
1700	558	0.28	660	0.39	746	0.49	824	0.59	896	0.70
1800	584	0.33	682	0.44	766	0.55	842	0.66	912	0.77
1900	611	0.38	706	0.50	788	0.61	861	0.72	930	0.84
2000	639	0.44	731	0.56	810	0.68	882	0.80	948	0.92

AIRFLOW (Cfm)	AVAILABLE EXTERNAL STATIC PRESSURE (in. wg)									
	1.2		1.4		1.6		1.8		2.0	
	Rpm	Bhp	Rpm	Bhp	Rpm	Bhp	Rpm	Bhp	Rpm	Bhp
1200	922	0.55	996	0.65	1066	0.75	1133	0.86	1196	0.97
1300	926	0.59	999	0.69	1068	0.80	1133	0.92	1196	1.03
1400	933	0.64	1004	0.75	1071	0.86	1136	0.98	1197	1.10
1500	942	0.69	1011	0.80	1077	0.92	1140	1.04	1200	1.17
1600	952	0.75	1020	0.87	1084	0.99	1146	1.11	1205	1.24
1700	965	0.82	1030	0.94	1093	1.06	1153	1.19	1211	1.32
1800	979	0.89	1043	1.01	1104	1.14	1163	1.27	1220	1.41
1900	995	0.97	1057	1.09	1116	1.22	1174	1.36	1229	1.50
2000	1012	1.05	1072	1.18	1130	1.32	1186	1.46	1240	1.60

LEGEND

Bhp — Brake Horsepower
 High Range Motor/Drive Required

NOTES:

1. Motor drive range is 596 to 910 rpm for low range motor/drive and 828 to 1173 rpm for high range motor/drive. All other rpms require a field-supplied drive.
2. Maximum continuous bhp is 0.85 for low range motor/drive and 1.60 (single phase) and 2.40 (3 phase) for high range motor/drive.
3. See page 35 for General Fan Performance Notes.

Table 24 — Fan Performance — 48PGF/N05 Horizontal Units

AIRFLOW (Cfm)	AVAILABLE EXTERNAL STATIC PRESSURE (in. wg)									
	0.2		0.4		0.6		0.8		1.0	
	Rpm	Bhp	Rpm	Bhp	Rpm	Bhp	Rpm	Bhp	Rpm	Bhp
1200	456	0.13	574	0.20	675	0.28	766	0.37	850	0.46
1300	477	0.16	591	0.23	688	0.32	776	0.41	857	0.50
1400	500	0.18	610	0.27	703	0.36	788	0.45	867	0.55
1500	524	0.22	630	0.31	720	0.40	802	0.50	879	0.60
1600	550	0.26	652	0.35	739	0.45	819	0.55	893	0.66
1700	576	0.30	675	0.40	759	0.50	836	0.61	908	0.72
1800	604	0.35	699	0.46	781	0.57	856	0.68	925	0.79
1900	633	0.41	724	0.52	804	0.63	876	0.75	944	0.87
2000	662	0.47	750	0.59	828	0.71	898	0.83	964	0.95

AIRFLOW (Cfm)	AVAILABLE EXTERNAL STATIC PRESSURE (in. wg)									
	1.2		1.4		1.6		1.8		2.0	
	Rpm	Bhp	Rpm	Bhp	Rpm	Bhp	Rpm	Bhp	Rpm	Bhp
1200	929	0.56	1003	0.66	1073	0.76	1139	0.87	1202	0.98
1300	934	0.60	1006	0.71	1075	0.82	1140	0.93	1202	1.05
1400	941	0.65	1012	0.76	1079	0.87	1143	0.99	1204	1.11
1500	951	0.71	1020	0.82	1085	0.94	1148	1.06	1208	1.18
1600	963	0.77	1029	0.89	1093	1.01	1155	1.13	1214	1.26
1700	976	0.84	1041	0.96	1103	1.08	1163	1.21	1221	1.34
1800	991	0.91	1054	1.04	1115	1.16	1174	1.30	1230	1.43
1900	1008	0.99	1070	1.12	1129	1.25	1186	1.39	1241	1.53
2000	1026	1.08	1086	1.21	1144	1.35	1199	1.49	1253	1.63

LEGEND
Bhp — Brake Horsepower
 High Range Motor/Drive Required
 Field-Supplied Motor Required (Single Phase)

NOTES:
 1. Motor drive range is 596 to 910 rpm for low range motor/drive and 828 to 1173 rpm for high range motor/drive. All other rpms require a field-supplied drive.
 2. Maximum continuous bhp is 0.85 for low range motor/drive and 1.60 (single phase) and 2.40 (3 phase) for high range motor/drive.
 3. See page 35 for General Fan Performance Notes.

Table 25 — Fan Performance — 48PGD/L06 Horizontal Units

AIRFLOW (Cfm)	AVAILABLE EXTERNAL STATIC PRESSURE (in. wg)									
	0.2		0.4		0.6		0.8		1.0	
	Rpm	Bhp	Rpm	Bhp	Rpm	Bhp	Rpm	Bhp	Rpm	Bhp
1500	521	0.22	628	0.31	718	0.40	800	0.49	877	0.60
1600	546	0.25	649	0.35	737	0.45	816	0.55	890	0.65
1700	572	0.30	671	0.40	757	0.50	834	0.61	906	0.72
1800	599	0.35	695	0.45	777	0.56	852	0.67	922	0.79
1900	627	0.40	719	0.51	799	0.63	872	0.74	940	0.86
2000	655	0.46	745	0.58	822	0.70	893	0.82	959	0.94
2100	684	0.53	771	0.66	846	0.78	915	0.91	979	1.03
2200	714	0.61	797	0.74	871	0.87	938	1.00	1001	1.13
2300	744	0.69	824	0.83	896	0.96	961	1.10	1022	1.24
2400	775	0.78	852	0.92	922	1.06	985	1.21	1045	1.35
2500	806	0.88	880	1.03	948	1.18	1010	1.32	1069	1.47

AIRFLOW (Cfm)	AVAILABLE EXTERNAL STATIC PRESSURE (in. wg)									
	1.2		1.4		1.6		1.8		2.0	
	Rpm	Bhp	Rpm	Bhp	Rpm	Bhp	Rpm	Bhp	Rpm	Bhp
1500	949	0.70	1018	0.82	1083	0.93	1146	1.05	1207	1.18
1600	961	0.77	1027	0.88	1091	1.00	1153	1.13	1212	1.26
1700	974	0.83	1039	0.95	1101	1.08	1161	1.21	1219	1.34
1800	988	0.91	1052	1.03	1112	1.16	1171	1.29	1227	1.43
1900	1004	0.99	1066	1.11	1125	1.25	1182	1.38	1238	1.52
2000	1022	1.07	1082	1.20	1139	1.34	1195	1.48	1249	1.62
2100	1040	1.17	1099	1.30	1155	1.44	1209	1.59	1262	1.73
2200	1060	1.27	1117	1.41	1172	1.55	1225	1.70	1277	1.85
2300	1081	1.38	1136	1.52	1190	1.67	1242	1.82	1292	1.98
2400	1102	1.50	1156	1.65	1209	1.80	1259	1.96	1309	2.12
2500	1124	1.62	1177	1.78	1228	1.94	1278	2.10	1326	2.26

LEGEND
Bhp — Brake Horsepower
 Field-Supplied Motor Required (Single Phase)

NOTES:
 1. Motor drive range is 690 to 978 rpm for low range motor/drive and 929 to 1261 rpm for high range motor/drive. All other rpms require a field-supplied drive.
 2. Maximum continuous bhp is 0.85 (single phase) and 2.40 (3 phase) for low range motor/drive and 1.60 (single phase) and 2.40 (3 phase) for high range motor/drive.
 3. See page 35 for General Fan Performance Notes.

Table 26 — Fan Performance — 48PGE/M06 Horizontal Units

AIRFLOW (Cfm)	AVAILABLE EXTERNAL STATIC PRESSURE (in. wg)									
	0.2		0.4		0.6		0.8		1.0	
	Rpm	Bhp	Rpm	Bhp	Rpm	Bhp	Rpm	Bhp	Rpm	Bhp
1500	536	0.23	640	0.32	729	0.41	811	0.51	887	0.61
1600	563	0.27	663	0.36	749	0.46	828	0.56	901	0.67
1700	590	0.31	686	0.42	770	0.52	846	0.62	917	0.74
1800	619	0.37	711	0.47	792	0.58	866	0.69	935	0.81
1900	648	0.43	737	0.54	816	0.65	887	0.77	954	0.89
2000	678	0.49	764	0.61	840	0.73	909	0.85	975	0.98
2100	709	0.56	792	0.69	865	0.81	933	0.94	996	1.07
2200	740	0.65	820	0.78	891	0.91	957	1.04	1019	1.17
2300	772	0.73	849	0.87	918	1.01	982	1.14	1042	1.28
2400	804	0.83	879	0.97	946	1.12	1008	1.26	1066	1.40
2500	837	0.94	909	1.09	974	1.24	1034	1.38	1092	1.53

AIRFLOW (Cfm)	AVAILABLE EXTERNAL STATIC PRESSURE (in. wg)									
	1.2		1.4		1.6		1.8		2.0	
	Rpm	Bhp	Rpm	Bhp	Rpm	Bhp	Rpm	Bhp	Rpm	Bhp
1500	958	0.72	1027	0.83	1092	0.95	1154	1.07	1214	1.20
1600	971	0.78	1037	0.90	1101	1.02	1162	1.15	1221	1.28
1700	985	0.85	1049	0.97	1111	1.10	1171	1.23	1228	1.36
1800	1001	0.93	1063	1.05	1124	1.18	1182	1.32	1238	1.45
1900	1018	1.01	1079	1.14	1138	1.27	1194	1.41	1249	1.55
2000	1036	1.10	1096	1.24	1153	1.37	1208	1.51	1262	1.66
2100	1056	1.20	1114	1.34	1170	1.48	1224	1.63	1276	1.78
2200	1077	1.31	1134	1.45	1188	1.60	1241	1.75	1292	1.90
2300	1099	1.43	1154	1.57	1207	1.72	1259	1.88	1309	2.03
2400	1122	1.55	1176	1.70	1228	1.86	1278	2.02	1327	2.18
2500	1146	1.69	1198	1.84	1249	2.00	1298	2.16	1346	2.33

LEGEND

Bhp — Brake Horsepower
 — Field-Supplied Motor Required (Single Phase)

NOTES:

- Motor drive range is 690 to 978 rpm for low range motor/drive and 929 to 1261 rpm for high range motor/drive. All other rpms require a field-supplied drive.
- Maximum continuous bhp is 0.85 (single phase) and 2.40 (3 phase) for low range motor/drive and 1.60 (single phase) and 2.40 (3 phase) for high range motor/drive.
- See page 35 for General Fan Performance Notes.

Table 27 — Fan Performance — 48PGF/N06 Horizontal Units

AIRFLOW (Cfm)	AVAILABLE EXTERNAL STATIC PRESSURE (in. wg)									
	0.2		0.4		0.6		0.8		1.0	
	Rpm	Bhp	Rpm	Bhp	Rpm	Bhp	Rpm	Bhp	Rpm	Bhp
1500	551	0.24	653	0.33	741	0.42	821	0.52	896	0.62
1600	579	0.28	676	0.38	761	0.48	839	0.58	912	0.69
1700	608	0.33	701	0.43	783	0.54	858	0.64	929	0.76
1800	638	0.39	727	0.49	807	0.60	879	0.71	948	0.83
1900	668	0.45	755	0.56	831	0.68	902	0.79	968	0.91
2000	700	0.52	783	0.64	857	0.76	925	0.88	990	1.01
2100	732	0.60	812	0.72	884	0.85	950	0.97	1013	1.11
2200	765	0.68	842	0.81	912	0.95	976	1.08	1037	1.21
2300	799	0.78	873	0.92	940	1.05	1002	1.19	1062	1.33
2400	833	0.88	904	1.03	969	1.17	1030	1.31	1087	1.46
2500	867	1.00	936	1.15	999	1.30	1058	1.44	1114	1.60

AIRFLOW (Cfm)	AVAILABLE EXTERNAL STATIC PRESSURE (in. wg)									
	1.2		1.4		1.6		1.8		2.0	
	Rpm	Bhp	Rpm	Bhp	Rpm	Bhp	Rpm	Bhp	Rpm	Bhp
1500	968	0.73	1035	0.85	1100	0.97	1162	1.09	1222	1.21
1600	981	0.80	1047	0.92	1110	1.04	1171	1.16	1229	1.29
1700	996	0.87	1060	0.99	1121	1.12	1181	1.25	1238	1.38
1800	1013	0.95	1075	1.08	1135	1.21	1193	1.34	1248	1.48
1900	1031	1.04	1092	1.17	1150	1.30	1206	1.44	1261	1.58
2000	1051	1.14	1110	1.27	1166	1.41	1221	1.55	1275	1.69
2100	1072	1.24	1129	1.38	1185	1.52	1238	1.67	1290	1.82
2200	1094	1.35	1150	1.50	1204	1.64	1256	1.79	1307	1.95
2300	1118	1.48	1172	1.62	1225	1.77	1275	1.93	1325	2.09
2400	1142	1.61	1195	1.76	1246	1.92	1296	2.07	1344	2.24
2500	1168	1.75	1219	1.91	1269	2.07	1317	2.23	1365	2.40

LEGEND

Bhp — Brake Horsepower
 — Field-Supplied Motor Required (Single Phase)

NOTES:

- Motor drive range is 690 to 978 rpm for low range motor/drive and 929 to 1261 rpm for high range motor/drive. All other rpms require a field-supplied drive.
- Maximum continuous bhp is 0.85 (single phase) and 2.40 (3 phase) for low range motor/drive and 1.60 (single phase) and 2.40 (3 phase) for high range motor/drive.
- See page 35 for General Fan Performance Notes.

Table 28 — Fan Performance — 48PGD/L07 Horizontal Units

AIRFLOW (Cfm)	AVAILABLE EXTERNAL STATIC PRESSURE (in. wg)									
	0.2		0.4		0.6		0.8		1.0	
	Rpm	Bhp	Rpm	Bhp	Rpm	Bhp	Rpm	Bhp	Rpm	Bhp
1800	614	0.36	707	0.47	788	0.58	863	0.69	932	0.80
1900	642	0.42	732	0.53	811	0.64	883	0.76	950	0.88
2000	671	0.48	758	0.60	835	0.72	905	0.84	970	0.97
2100	701	0.55	785	0.68	859	0.80	927	0.93	991	1.06
2200	731	0.63	812	0.76	884	0.89	950	1.02	1012	1.16
2300	762	0.72	840	0.85	910	0.99	975	1.13	1035	1.27
2400	793	0.81	869	0.95	937	1.10	999	1.24	1058	1.38
2500	825	0.91	898	1.06	964	1.21	1025	1.36	1082	1.51
2600	856	1.03	927	1.18	991	1.33	1051	1.49	1107	1.64
2700	889	1.15	957	1.31	1019	1.47	1077	1.63	1132	1.79
2800	921	1.28	987	1.44	1048	1.61	1104	1.78	1158	1.94
2900	953	1.42	1017	1.59	1076	1.76	1132	1.94	1184	2.11
3000	986	1.57	1048	1.75	1106	1.93	1160	2.10	1211	2.28

AIRFLOW (Cfm)	AVAILABLE EXTERNAL STATIC PRESSURE (in. wg)									
	1.2		1.4		1.6		1.8		2.0	
	Rpm	Bhp	Rpm	Bhp	Rpm	Bhp	Rpm	Bhp	Rpm	Bhp
1800	997	0.92	1060	1.05	1121	1.18	1179	1.31	1235	1.45
1900	1014	1.01	1075	1.13	1134	1.27	1191	1.40	1246	1.54
2000	1032	1.09	1092	1.23	1149	1.36	1204	1.50	1258	1.65
2100	1051	1.19	1109	1.33	1165	1.47	1219	1.61	1272	1.76
2200	1071	1.30	1128	1.44	1183	1.58	1235	1.73	1287	1.88
2300	1093	1.41	1148	1.56	1201	1.70	1253	1.86	1303	2.01
2400	1115	1.53	1168	1.68	1220	1.84	1271	1.99	1320	2.15
2500	1137	1.66	1190	1.82	1241	1.98	1290	2.14	1338	2.30
2600	1161	1.80	1212	1.96	1262	2.12	1310	2.29	—	—
2700	1185	1.95	1235	2.12	1284	2.28	—	—	—	—
2800	1209	2.11	1259	2.28	—	—	—	—	—	—
2900	1235	2.28	—	—	—	—	—	—	—	—
3000	—	—	—	—	—	—	—	—	—	—

LEGEND
Bhp — Brake Horsepower

- NOTES:
1. Motor drive range is 796 to 1128 rpm for low range motor/drive and 1150 to 1438 rpm for high range motor/drive. All other rpms require a field-supplied drive.
 2. Maximum continuous bhp is 2.40 for low range motor/drive and 3.10 for high range motor/drive.
 3. See page 35 for General Fan Performance Notes.

Table 29 — Fan Performance — 48PGE/M07 Horizontal Units

AIRFLOW (Cfm)	AVAILABLE EXTERNAL STATIC PRESSURE (in. wg)									
	0.2		0.4		0.6		0.8		1.0	
	Rpm	Bhp	Rpm	Bhp	Rpm	Bhp	Rpm	Bhp	Rpm	Bhp
1800	633	0.38	723	0.49	803	0.60	876	0.71	944	0.83
1900	663	0.44	750	0.56	827	0.67	898	0.79	964	0.91
2000	694	0.51	777	0.63	852	0.75	921	0.87	985	1.00
2100	725	0.59	806	0.71	878	0.84	945	0.96	1007	1.09
2200	757	0.67	835	0.80	905	0.93	969	1.06	1030	1.20
2300	789	0.76	864	0.90	932	1.04	995	1.17	1055	1.31
2400	822	0.86	894	1.01	960	1.15	1022	1.29	1079	1.44
2500	855	0.98	925	1.12	989	1.27	1049	1.42	1105	1.57
2600	889	1.10	956	1.25	1018	1.40	1076	1.56	1131	1.71
2700	923	1.23	988	1.39	1048	1.55	1105	1.71	1158	1.87
2800	957	1.37	1020	1.53	1079	1.70	1134	1.87	1186	2.03
2900	991	1.52	1052	1.69	1109	1.86	1163	2.04	1214	2.21
3000	1026	1.68	1085	1.86	1140	2.04	1193	2.22	1243	2.40

AIRFLOW (Cfm)	AVAILABLE EXTERNAL STATIC PRESSURE (in. wg)									
	1.2		1.4		1.6		1.8		2.0	
	Rpm	Bhp	Rpm	Bhp	Rpm	Bhp	Rpm	Bhp	Rpm	Bhp
1800	1010	0.95	1072	1.07	1132	1.20	1190	1.33	1246	1.47
1900	1027	1.03	1088	1.16	1146	1.30	1203	1.43	1258	1.57
2000	1047	1.13	1106	1.26	1162	1.40	1218	1.54	1271	1.68
2100	1067	1.23	1124	1.37	1180	1.51	1234	1.65	1286	1.80
2200	1089	1.34	1145	1.48	1199	1.63	1251	1.78	1302	1.93
2300	1111	1.46	1166	1.60	1218	1.76	1269	1.91	1319	2.07
2400	1135	1.59	1188	1.74	1239	1.89	1289	2.05	1338	2.21
2500	1159	1.73	1211	1.88	1261	2.04	1310	2.20	1357	2.37
2600	1184	1.87	1235	2.03	1284	2.20	1331	2.37	—	—
2700	1210	2.03	1259	2.20	1307	2.37	—	—	—	—
2800	1236	2.20	1284	2.37	—	—	—	—	—	—
2900	1263	2.38	—	—	—	—	—	—	—	—
3000	—	—	—	—	—	—	—	—	—	—

LEGEND
Bhp — Brake Horsepower

- NOTES:
1. Motor drive range is 796 to 1128 rpm for low range motor/drive and 1150 to 1438 rpm for high range motor/drive. All other rpms require a field-supplied drive.
 2. Maximum continuous bhp is 2.40 for low range motor/drive and 3.10 for high range motor/drive.
 3. See page 35 for General Fan Performance Notes.

Table 30 — Fan Performance — 48PGF/N07 Horizontal Units

AIRFLOW (Cfm)	AVAILABLE EXTERNAL STATIC PRESSURE (in. wg)									
	0.2		0.4		0.6		0.8		1.0	
	Rpm	Bhp	Rpm	Bhp	Rpm	Bhp	Rpm	Bhp	Rpm	Bhp
1800	651	0.40	739	0.51	817	0.62	889	0.73	957	0.85
1900	683	0.47	767	0.58	843	0.69	912	0.81	978	0.93
2000	715	0.54	796	0.66	869	0.78	937	0.90	1000	1.03
2100	748	0.62	826	0.75	896	0.87	962	1.00	1024	1.13
2200	781	0.71	856	0.84	925	0.97	988	1.10	1048	1.24
2300	815	0.81	888	0.95	954	1.08	1015	1.22	1074	1.36
2400	850	0.92	919	1.06	983	1.20	1043	1.35	1100	1.49
2500	885	1.04	952	1.18	1014	1.33	1072	1.48	1127	1.63
2600	920	1.17	985	1.32	1045	1.47	1101	1.63	1155	1.79
2700	956	1.31	1018	1.47	1076	1.63	1131	1.79	1184	1.95
2800	992	1.46	1052	1.62	1108	1.79	1162	1.96	1213	2.12
2900	1028	1.62	1086	1.79	1141	1.96	1193	2.14	1243	2.31
3000	1064	1.80	1121	1.98	1174	2.15	1225	2.33	—	—

AIRFLOW (Cfm)	AVAILABLE EXTERNAL STATIC PRESSURE (in. wg)									
	1.2		1.4		1.6		1.8		2.0	
	Rpm	Bhp	Rpm	Bhp	Rpm	Bhp	Rpm	Bhp	Rpm	Bhp
1800	1022	0.97	1083	1.10	1143	1.23	1201	1.36	1256	1.50
1900	1041	1.06	1101	1.19	1159	1.32	1215	1.46	1269	1.60
2000	1061	1.16	1119	1.29	1176	1.43	1230	1.57	1283	1.72
2100	1083	1.26	1140	1.40	1194	1.55	1248	1.69	1299	1.84
2200	1106	1.38	1161	1.52	1214	1.67	1266	1.82	1317	1.98
2300	1130	1.51	1183	1.65	1236	1.81	1286	1.96	1335	2.12
2400	1155	1.64	1207	1.80	1258	1.95	1307	2.11	1355	2.27
2500	1180	1.79	1231	1.95	1281	2.11	1329	2.27	—	—
2600	1207	1.95	1257	2.11	1305	2.27	—	—	—	—
2700	1234	2.11	1283	2.28	—	—	—	—	—	—
2800	1262	2.29	—	—	—	—	—	—	—	—
2900	—	—	—	—	—	—	—	—	—	—
3000	—	—	—	—	—	—	—	—	—	—

LEGEND
Bhp — Brake Horsepower

- NOTES:
1. Motor drive range is 796 to 1128 rpm for low range motor/drive and 1150 to 1438 rpm for high range motor/drive. All other rpms require a field-supplied drive.
 2. Maximum continuous bhp is 2.40 for low range motor/drive and 3.10 for high range motor/drive.
 3. See below for General Fan Performance Notes.

GENERAL NOTES FOR FAN PERFORMANCE DATA TABLES

1. Static pressure losses (i.e., economizer, etc.) must be added to external static pressure before entering Fan Performance table.
2. Interpolation is permissible. Do not extrapolate.
3. Fan performance is based on wet coils, clean filters, and casing losses. Refer to the unit Product Data literature for Accessory/FIOP Static Pressure information.
4. Extensive motor and drive testing on these units ensures that the full horsepower range of the motor can be utilized with confidence. Using the fan motors up to the bhp rating shown will not result in nuisance tripping or premature motor failure. Unit warranty will not be affected.
5. Use of a field-supplied motor may affect wire size. Recalculate the unit power supply MCA and MOCP if required. Contact the local Carrier representative for details.
6. Use the following formula to calculate input watts:
Input Watts = Bhp x (746/Motor Eff)

Table 31 — Operation Air Quantity Limits

UNIT 48PG	COOLING (cfm)		HEATING (cfm)	
	Min	Max	Min	Max
03	600	1000	600	1680
04 (Low Heat)	900	1500	600	1680
04 (Med Heat)	900	1500	940	2810
04 (High Heat)	900	1500	1130	2820
05 (Low Heat)	1200	2000	600	1680
05 (Med Heat)	1200	2000	940	2810
05 (High Heat)	1200	2000	1130	2820
06 (Low Heat)	1500	2500	940	2810
06 (Med Heat)	1500	2500	1130	2820
06 (High Heat)	1500	2500	1510	2520
07 (Low Heat)	1800	3000	940	2810
07 (Med Heat)	1800	3000	1130	2820
07 (High Heat)	1800	3000	1510	2520

Table 32 — Evaporator Fan Motor Specifications

48PG	DRIVE	VOLTAGE/PHASE	MOTOR P/N	EFFICIENCY	MAX BHP	MAX AMPS
03	Low	208/1ph	HC52EE208	0.73	0.85	4.0
		230/1ph	HC52EE208	0.73	0.85	4.0
	High	208/1ph	HC52EE208	0.73	0.85	4.0
		230/1ph	HC52EE208	0.73	0.85	4.0
04	Low	208/1ph	HC52EE208	0.73	0.85	4.0
		230/1ph	HC52EE208	0.73	0.85	4.0
		208/3ph	HC52EE208	0.73	0.85	4.0
		230/3ph	HC52EE208	0.73	0.85	4.0
		460/3ph	HC52EE460	0.73	0.85	2.0
	High	575/3ph	HC52EE576	0.73	0.85	1.6
		208/1ph	HC52EE208	0.73	0.85	4.0
		230/1ph	HC52EE208	0.73	0.85	4.0
		208/3ph	HC52EE208	0.73	0.85	4.0
		230/3ph	HC52EE208	0.73	0.85	4.0
05	Low	460/3ph	HC52EE460	0.73	0.85	2.0
		575/3ph	HC52EE576	0.73	0.85	1.6
		208/1ph	HC54FB230	0.78	1.6	8.3
		230/1ph	HC54FB230	0.78	1.6	8.3
		208/3ph	HD56FE652	0.80	2.4	6.4
	High	230/3ph	HD56FE652	0.80	2.4	6.4
		460/3ph	HD56FE652	0.80	2.4	3.2
		575/3ph	HD56FE575	0.80	2.4	2.4
		208/1ph	HC52EE208	0.73	0.85	4.0
		230/1ph	HC52EE208	0.73	0.85	4.0
06	Low	208/3ph	HC52EE208	0.73	0.85	4.0
		230/3ph	HD56FE652	0.80	2.4	6.4
		460/3ph	HD56FE652	0.80	2.4	3.2
		575/3ph	HD56FE575	0.80	2.4	2.4
		208/1ph	HC54FB230	0.78	1.6	8.3
	High	230/1ph	HC54FB230	0.78	1.6	8.3
		208/3ph	HD56FE652	0.80	2.4	6.4
		230/3ph	HD56FE652	0.80	2.4	6.4
		460/3ph	HD56FE652	0.80	2.4	3.2
		575/3ph	HD56FE575	0.80	2.4	2.4
07	Low	208/3ph	HD56FE652	0.80	2.4	6.4
		230/3ph	HD56FE652	0.80	2.4	6.4
		460/3ph	HD56FE652	0.80	2.4	3.2
		575/3ph	HD56FE575	0.80	2.4	2.4
	High	208/3ph	HD58FE653	0.84	3.1	8.8
		230/3ph	HD58FE653	0.84	3.1	8.8
		460/3ph	HD58FE653	0.84	3.1	4.4
		575/3ph	HD58FE576	0.82	3.7	4.2

NOTES:

- Extensive motor and electrical testing ensures that the motors can be utilized with confidence up to the maximum applied bhp, watts, and amps. Using the fan motor up to the maximum ratings shown will not result in nuisance tripping or premature motor failure. Unit warranty will not be affected.
- Convert bhp to watts using the following formula:

$$\text{watts} = \frac{\text{bhp} (746)}{\text{motor efficiency}}$$

- The EPACT (Energy Policy Act of 1992) regulates energy requirements for specific types of indoor fan motors. Motors regulated by EPACT include any general purpose, T-frame (three-digit, 143 and larger), single-speed, foot mounted, polyphase, squirrel cage induction motors of NEMA (National Electrical Manufacturers Association) design A and B, manufactured for use in the United States. Ranging from 1 to 200 Hp, these continuous-duty motors operate on 230 and 460 volt, 60 Hz power. If a motor does not fit into these specifications, the motor does not have to be replaced by an EPACT-compliant energy-efficient motor. Variable-speed motors are exempt from EPACT compliance requirements. Therefore, the indoor fan motors for Carrier 48PG03-07 units are exempt from these requirements.

Table 33 — Fan Rpm at Motor Pulley Settings*

UNIT 48PG	DRIVE	MOTOR PULLEY TURNS OPEN										
		0	1/2	1	1 1/2	2	2 1/2	3	3 1/2	4	4 1/2	5
03	Low	736	710	685	660	634	609	583	558	533	507	482
	High	1001	966	932	897	863	828	794	759	725	690	656
04	Low	736	710	685	660	634	609	583	558	533	507	482
	High	1128	1095	1062	1028	995	962	929	896	863	829	796
05	Low	910	878	847	815	784	753	721	690	659	627	596
	High	1173	1139	1104	1070	1035	1001	966	932	897	863	828
06	Low	978	949	920	891	863	834	805	776	748	719	690
	High	1261	1227	1194	1161	1128	1095	1062	1028	995	962	929
07	Low	1128	1095	1062	1028	995	962	929	896	863	829	796
	High	1438	1409	1380	1351	1323	1294	1265	1236	1208	1179	1150

*Approximate fan rpm shown, based on 1725 rpm motor.

SERVICE

⚠ WARNING

Before performing service or maintenance operations on unit, turn off main power switch to unit. Electrical shock could cause personal injury.

⚠ CAUTION

Puron® (R-410A) refrigerant systems operate at higher pressures than standard R-22 systems. Do not use R-22 service equipment or components on Puron refrigerant equipment. If service equipment is not rated for Puron refrigerant, equipment damage or personal injury may result.

⚠ WARNING

1. Improper installation, adjustment, alteration, service, or maintenance can cause property damage, personal injury, or loss of life. Refer to the User's Information Manual provided with this unit for more details.
2. Do not store or use gasoline or other flammable vapors and liquids in the vicinity of this or any other appliance.

What to do if you smell gas:

1. DO NOT try to light any appliance.
2. DO NOT touch any electrical switch, or use any phone in your building.
3. IMMEDIATELY call your gas supplier from a neighbor's phone. Follow the gas supplier's instructions.
4. If you cannot reach your gas supplier, call the fire department.

⚠ WARNING

Disconnect gas piping from unit when pressure testing at pressure greater than 0.5 psig. Pressures greater than 0.5 psig will cause gas valve damage resulting in hazardous condition. If gas valve is subjected to pressure greater than 0.5 psig, it *must* be replaced before use. When pressure testing field-supplied gas piping at pressures of 0.5 psig or less, a unit connected to such piping must be isolated by closing the manual gas valve(s).

Cleaning — Inspect unit interior at beginning of each heating and cooling season and as operating conditions require. Remove unit top panel and/or side panels for access to unit interior.

COIL MAINTENANCE AND CLEANING RECOMMENDATION — Routine cleaning of coil surfaces is essential to maintain proper operation of the unit. Elimination of contamination and removal of harmful residues will greatly increase the life of the coil and extend the life of the unit. The following maintenance and cleaning procedures are recommended as part of the routine maintenance activities to extend the life of the coil.

Remove Surface Loaded Fibers — Surface loaded fibers or dirt should be removed with a vacuum cleaner. If a vacuum cleaner is not available, a soft non-metallic bristle brush may be used. In either case, the tool should be applied in the direction of the fins. Coil surfaces can be easily damaged (fin edges can be easily bent over and damage to the coating of a protected coil) if the tool is applied across the fins.

NOTE: Use of a water stream, such as a garden hose, against a surface loaded coil will drive the fibers and dirt into the coil. This will make cleaning efforts more difficult. Surface loaded

fibers must be completely removed prior to using low velocity clean water rinse.

Periodic Clean Water Rinse — A periodic clean water rinse is very beneficial for coils that are applied in coastal or industrial environments. However, it is very important that the water rinse is made with very low velocity water stream to avoid damaging the fin edges. Monthly cleaning as described below is recommended.

Routine Cleaning of Coil Surfaces — Monthly cleaning with Totaline® environmentally sound coil cleaner is essential to extend the life of coils. This cleaner is available from Carrier Replacement parts division as part number P902-0301 for a one gallon container, and part number P902-0305 for a 5 gallon container. It is recommended that all coils, including standard aluminum, pre-coated, copper/copper or E-coated coils be cleaned with the Totaline environmentally sound coil cleaner as described below. Coil cleaning should be part of the unit's regularly scheduled maintenance procedures to ensure long life of the coil. Failure to clean the coils may result in reduced durability in the environment.

Avoid the use of:

- coil brighteners
- acid cleaning prior to painting
- high pressure washers
- poor quality water for cleaning

Totaline environmentally sound coil cleaner is non-flammable, hypoallergenic, nonbacterial, and a USDA accepted biodegradable agent that will not harm the coil or surrounding components such as electrical wiring, painted metal surfaces, or insulation. Use of non-recommended coil cleaners is strongly discouraged since coil and unit durability could be affected.

Totaline Environmentally Sound Coil Cleaner Application Equipment

- 2½ gallon garden sprayer
- water rinse with low velocity spray nozzle

⚠ CAUTION

Harsh chemicals, household bleach or acid or basic cleaners should not be used to clean outdoor or indoor coils of any kind. These cleaners can be very difficult to rinse out of the coil and can accelerate corrosion at the fin/tube interface where dissimilar materials are in contact. If there is dirt below the surface of the coil, use the Totaline environmentally sound coil cleaner as described above.

⚠ CAUTION

High velocity water from a pressure washer, garden hose, or compressed air should never be used to clean a coil. The force of the water or air jet will bend the fin edges and increase airside pressure drop. Reduced unit performance or nuisance unit shutdown may occur.

Totaline Environmentally Sound Coil Cleaner Application Instructions

1. Proper eye protection such as safety glasses is recommended during mixing and application.
2. Remove all surface loaded fibers and dirt with a vacuum cleaner as described above.
3. Thoroughly wet finned surfaces with clean water and a low velocity garden hose, being careful not to bend fins.
4. Mix Totaline environmentally sound coil cleaner in a 2½ gallon garden sprayer according to the instructions included with the cleaner. The optimum solution temperature is 100 F.

NOTE: Do NOT USE water in excess of 130 F, as the enzymatic activity will be destroyed.

5. Thoroughly apply Totaline® environmentally sound coil cleaner solution to all coil surfaces including finned area, tube sheets and coil headers.
6. Hold garden sprayer nozzle close to finned areas and apply cleaner with a vertical, up-and-down motion. Avoid spraying in horizontal pattern to minimize potential for fin damage.
7. Ensure cleaner thoroughly penetrates deep into finned areas.
8. Interior and exterior finned areas must be thoroughly cleaned.
9. Finned surfaces should remain wet with cleaning solution for 10 minutes.
10. Ensure surfaces are not allowed to dry before rinsing. Re-applying cleaner as needed to ensure 10-minute saturation is achieved.
11. Thoroughly rinse all surfaces with low velocity clean water using downward rinsing motion of water spray nozzle. Protect fins from damage from the spray nozzle.

CONDENSATE DRAIN PAN — Check and clean each year at the start of the cooling season.

To clean the condensate pan:

1. Disconnect condensate drain system from side or bottom drain connection.
2. Remove and clean trap.
3. Remove 4 screws securing condensate pan access cover to unit. Save screws and panel.
4. Slide condensate pan out from unit and clean. Pan is made of non-corrosive plastic. Use a mild cleaner to remove heavy deposits of dirt and grime.
5. Replace pan in unit.
6. Replace condensate pan access cover with 4 screws saved from Step 3.
7. Re-attach and prime condensate trap.
8. Connect condensate drainage system.

NOTE: During winter in low (subfreezing) temperature regions, add antifreeze solutions to the drain. Protect against contact with children, pets and animals.

FILTERS — Clean or replace at start of each heating and cooling season, or more often if operating conditions require. Refer to Table 1 for type and size.

OUTDOOR-AIR INLET SCREENS — Clean screens with steam or hot water and a mild detergent.

MAIN BURNER — At the beginning of each heating season, inspect for deterioration or blockage due to corrosion or other causes. Observe the main burner flames. Refer to Main Burners section on page 42.

FLUE GAS PASSAGEWAYS — The flue collector box and heat exchanger cells may be inspected by opening heat section access door (Fig. 6), flue box cover, and main burner assembly (Fig. 26). Refer to Main Burners section on page 42 for burner removal sequence. If cleaning is required, clean tubes with a wire brush.

COMBUSTION-AIR BLOWER — Clean periodically to assure proper airflow and heating efficiency. Inspect blower wheel every fall and periodically during heating season. For the first heating season, inspect blower wheel bi-monthly to determine proper cleaning frequency.

To inspect blower wheel, open heat section door. Using a flashlight, look into the flue exhaust duct to inspect. If cleaning is required, remove motor and wheel assembly by removing the screws holding the flue box cover to the flue box. See Fig. 26. Remove the screws holding the inducer housing to the inlet plate. The wheel can then be removed from the motor shaft and cleaned with a detergent or solvent. Replace the wheel onto the motor shaft in the correct position and reassemble the flue cover onto the flue box.

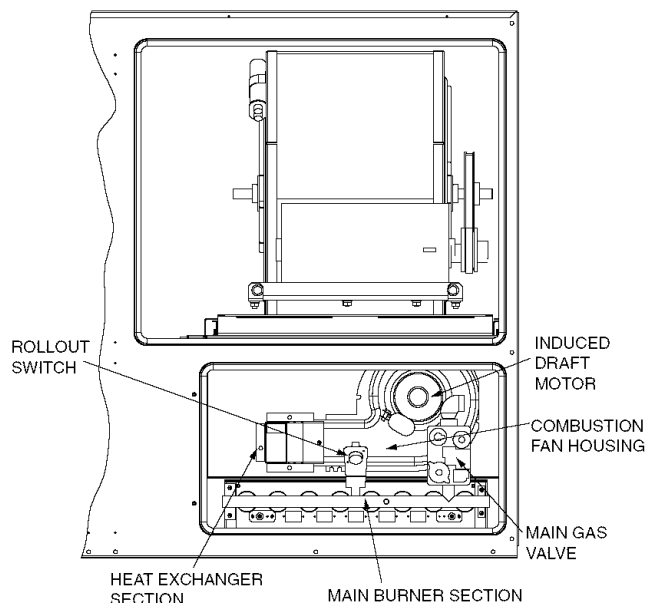

Fig. 26 — Typical Gas Heating Section

Lubrication

COMPRESSORS — Each compressor is charged with the correct amount of oil at the factory.

⚠ CAUTION

The compressor is in a Puron® refrigerant system and uses a polyolester (POE) oil. This oil is extremely hygroscopic, meaning it absorbs water readily. POE oils can absorb 15 times as much water as other oils designed for HCFC and CFC refrigerants. Avoid exposure of the oil to the atmosphere. Damage to components could result.

Polyolester (POE) compressor lubricants are known to cause long term damage to some synthetic roofing materials. Exposure, even if immediately cleaned up, may cause roofing materials to become brittle (leading to cracking) within a year. When performing any service which may risk exposure of compressor oil to the roof, take appropriate precautions to protect roofing. Procedures which risk oil leakage include compressor replacement, repairing refrigerant leaks, and replacing refrigerant components. To prepare rooftop:

1. Cover extended roof work area with an impermeable plastic dropcloth or tarp. Make sure a 10 x 10 ft area around the work area is covered.
2. Cover area in front of the unit service panel with a terry cloth shop towel to absorb lubricant spills and prevent run-offs. Towel will also protect dropcloth from tears caused by tools or components.
3. Place terry cloth shop towel inside the unit directly under components to be serviced to prevent spills through the bottom of the unit.
4. Perform the required service.
5. Remove and dispose of any oil contaminated material per local codes.

INDOOR FAN SHAFT BEARINGS — The indoor fan has permanently sealed bearings. No field lubrication is necessary.

CONDENSER AND EVAPORATOR-FAN MOTOR BEARINGS — The condenser-fan and evaporator-fan motors have permanently sealed bearings, so no field lubrication is necessary.

Evaporator Fan Service and Replacement — The 48PG units feature a slide-out fan deck for easy servicing of the indoor-fan motor, pulleys, belt, and bearings. To service components in this section, perform the following procedure:

1. Turn off unit power.
2. Open the fan section access door.
3. Remove two no. 10 screws at front of slide-out fan deck. Save screws. See Fig. 27.
4. Disconnect the electrical wires connected to the slide-out fan deck (supply air thermistor and fan status switch if installed). Wires may be damaged if not disconnected.
5. Fan deck can now be slid out to access serviceable components.

CAUTION

DO NOT SLIDE FAN DECK OUT PAST THE FAN DECK STOP. If further access is required, the fan deck must be supported. Make sure plugs and wiring are not pinched between fan housing and unit sheet metal post. Damage to unit may result.

6. To replace fan deck to operating position, slide fan deck back into the unit. Secure with the two no. 10 screws removed in Step 3.
7. Re-attach electrical wires.
8. Close fan section access door.
9. Restore power to unit.

Evaporator Fan Performance Adjustment (Fig. 27 and 28) — Fan motor pulleys are factory set for speed shown in Table 33.

To change fan speeds:

1. Shut off unit power supply.
2. Loosen nuts on the 4 carriage bolts in the mounting base. Using adjusting bolts and plate, slide motor and remove belt.
3. Loosen movable-pulley flange setscrew (see Fig. 28).
4. Screw movable flange toward fixed flange to increase speed and away from fixed flange to decrease speed. Increasing fan speed increases load on motor. Do not exceed maximum speed specified in Table 33. See Table 31 for air quantity limits.
5. Set movable flange at nearest keyway of pulley hub and tighten setscrew. (See Table 33 for speed change for each full turn of pulley flange.)
6. Replace belts.
7. Realign fan and motor pulleys:
 - a. Loosen fan pulley setscrews.
 - b. Slide fan pulley along fan shaft.
 - c. Make angular alignment by loosening motor from mounting plate.
8. Tighten belts.
9. Restore power to unit.

Evaporator Fan Belt Tension Adjustment — To adjust belt tension:

1. Turn off unit power.
2. Slide out fan deck to service position as shown in Evaporator Fan Service and Replacement section above.
3. Loosen motor mounting plate bolts.
4. Move motor mounting plate to adjust to proper belt tension. Motor adjuster bolts may be used to tighten belts. See Fig. 27. Do not overtighten belt.
5. Check for proper belt alignment. Adjust if necessary.
6. Tighten motor mounting plate bolts to lock motor in proper position.

7. Return fan deck back into operating position.
8. Restore power to unit.

Condenser-Fan Adjustment (Fig. 29)

1. Shut off unit power supply.
2. Remove condenser-fan assembly (grille, motor, motor cover, and fan) and loosen fan hub setscrews.
3. Adjust fan height as shown in Fig. 29.
4. Tighten setscrews and replace condenser-fan assembly.
5. Turn on power to unit.

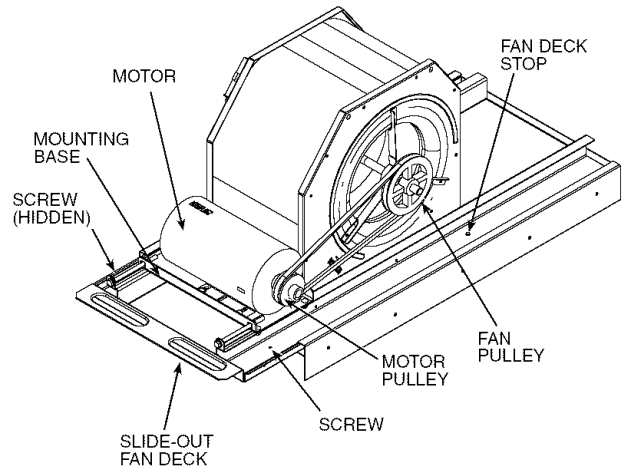

Fig. 27 — Evaporator-Fan Motor Adjustment

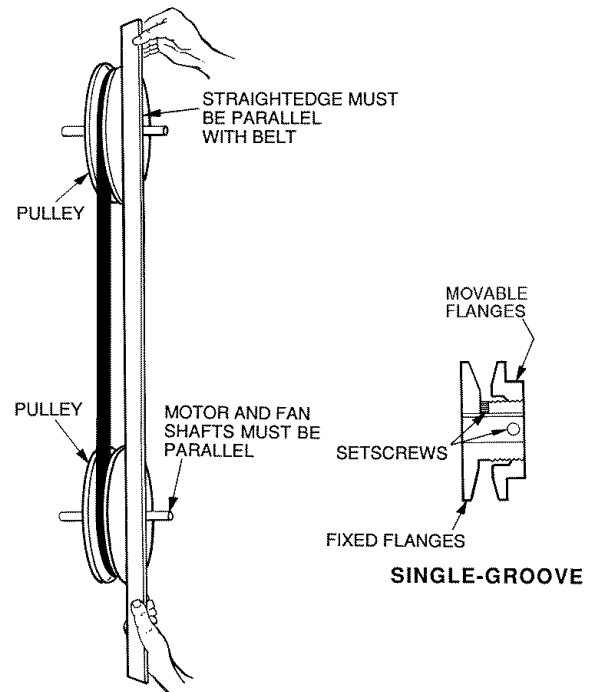

Fig. 28 — Evaporator-Fan Alignment and Adjustment

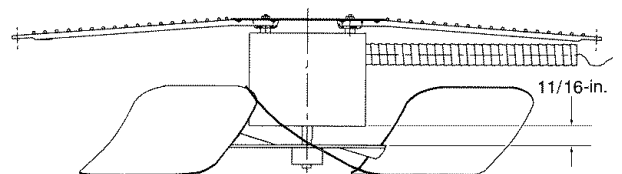

Fig. 29 — Condenser-Fan Adjustment

Verify Sensor Performance — Using an ohmmeter and a thermometer, compare measured temperature to the resistance shown in Table 34.

Table 34 — Sensor Temperature/Resistance Values

TEMPERATURE (F)	RESISTANCE (ohms)
-58	200,250
-40	100,680
-22	53,010
-4	29,091
14	16,590
32	9,795
50	5,970
68	3,747
77	3,000
86	2,416
104	1,597
122	1,080
140	746
158	525
176	376
185	321
194	274
212	203
230	153
248	116
257	102
266	89
284	70
302	55

Economizer Operation During Power Failure — Dampers have a spring return. In event of power failure, dampers will return to fully closed position until power is restored. *Do not manually operate damper motor.*

Evacuation — Proper evacuation of the system will remove noncondensables and ensure a tight, dry system before charging. Evacuate from both high and low side ports. Never use the system compressor as a vacuum pump. Refrigerant tubes and indoor coil should be evacuated to 500 microns. Always break a vacuum with dry nitrogen. The two possible methods are the deep vacuum method and the triple evacuation method.

DEEP VACUUM METHOD — The deep vacuum method requires a vacuum pump capable of pulling a minimum vacuum of 500 microns and a vacuum gage capable of accurately measuring this vacuum depth. The deep vacuum method is the most positive way of assuring a system is free of air and liquid water. (See Fig. 30.)

TRIPLE EVACUATION METHOD — The triple evacuation method should only be used when vacuum pump is capable of pumping down to 28 in. of mercury and system does not contain any liquid water. Proceed as follows:

1. Pump system down to 28 in. of mercury and allow pump to continue operating for an additional 15 minutes.
2. Close service valves and shut off vacuum pump.
3. Connect a nitrogen cylinder and regulator to system and open until system pressure is 2 psig.
4. Close service valve and allow system to stand for 1 hr. During this time, dry nitrogen will be able to diffuse throughout the system, absorbing moisture.
5. Repeat this procedure. System will then contain minimal amounts of contaminants and water vapor.

Refrigerant Charge — Amount of refrigerant charge is listed on unit nameplate. Refer to Carrier GTAC II; Module 5; Charging, Recovery, Recycling, and Reclamation section for charging methods and procedures. Unit panels must be in place when unit is operating during charging procedure.

Puron® (R-410A) refrigerant cylinders contain a dip tube which allows liquid refrigerant to flow from the cylinder in an upright position. Charge units with cylinder in the upright position and a commercial type metering device in the manifold hose.

⚠ CAUTION

This system uses Puron refrigerant which has higher pressures than R-22 and other refrigerants. No other refrigerant may be used in this system. Gage set, hoses, and recovery system must be designed to handle Puron refrigerant. If unsure about equipment, consult the equipment manufacturer. Damage to equipment or personal injury may result.

NOTE: Do not use recycled refrigerant as it may contain contaminants.

NO CHARGE — Use standard evacuating techniques. After evacuating system, weigh in the specified amount of refrigerant (refer to unit nameplate).

LOW CHARGE COOLING — Using cooling charging chart (see Fig. 31-35), add or remove refrigerant until conditions of the chart are met. An accurate pressure gage and temperature-sensing device is required. Charging is accomplished by ensuring the proper amount of liquid subcooling. Connect pressure gage to the compressor discharge service valve. Connect temperature sensing device to the liquid line between the condenser and the TXV (thermostatic expansion valve) and insulate it so that ambient temperature does not affect reading.

TO USE THE COOLING CHARGING CHART — Use the above temperature and pressure readings, and find the intersection point on the cooling charging chart. If intersection point on chart is above line, add refrigerant. If intersection point on chart is below line, carefully recover some of the charge. Recheck suction pressure as charge is adjusted.

NOTE: Indoor-air cfm must be within normal operating range of unit. All outdoor fans must be operating.

The TXV is set to maintain between 10 and 15 degrees of superheat at the compressors. The valves are factory set and cannot be adjusted. Do not use a TXV designed for use with R-22 refrigerant.

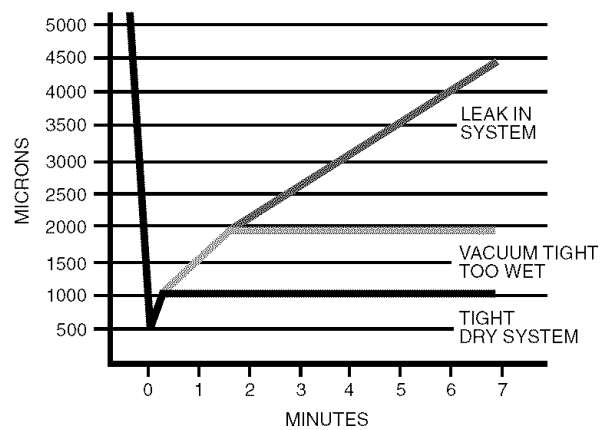

Fig. 30 — Deep Vacuum Graph

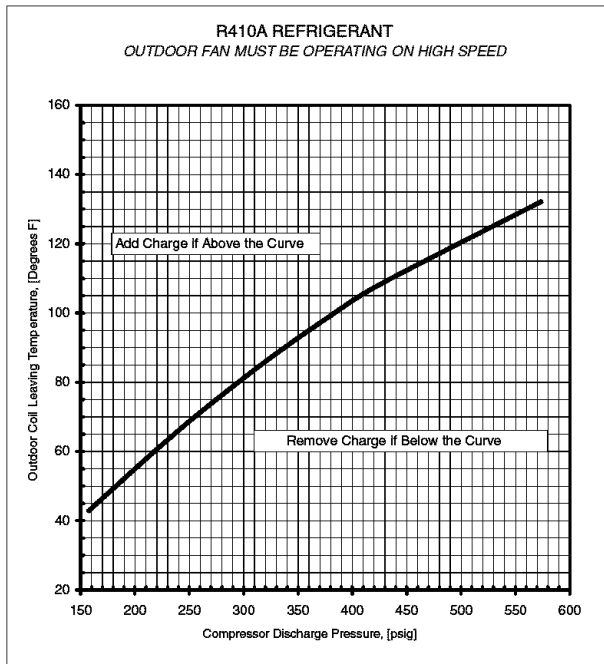

Fig. 31 — Charging Chart — 48PG03

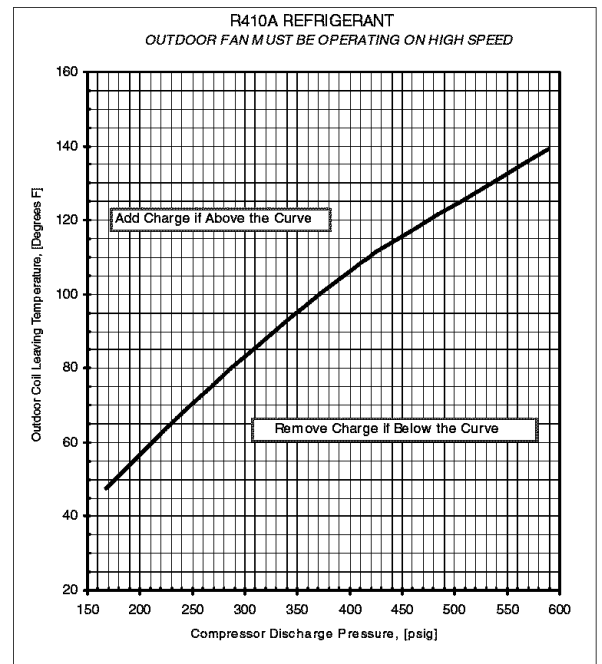

Fig. 33 — Charging Chart — 48PG05

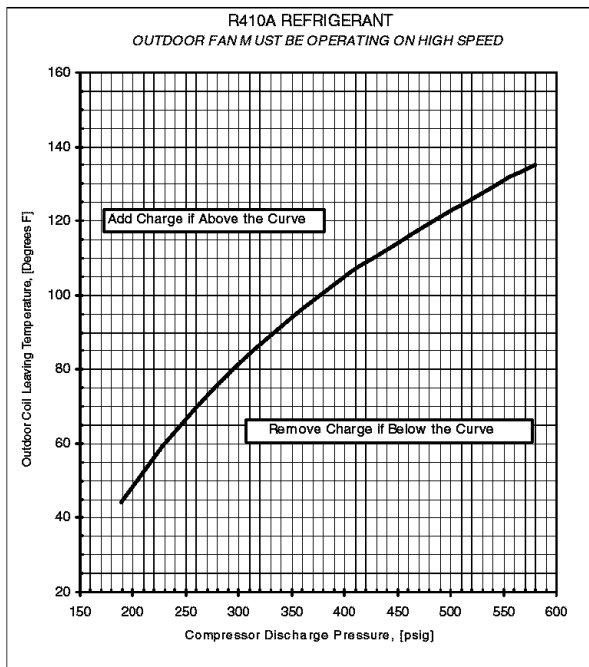

Fig. 32 — Charging Chart — 48PG04

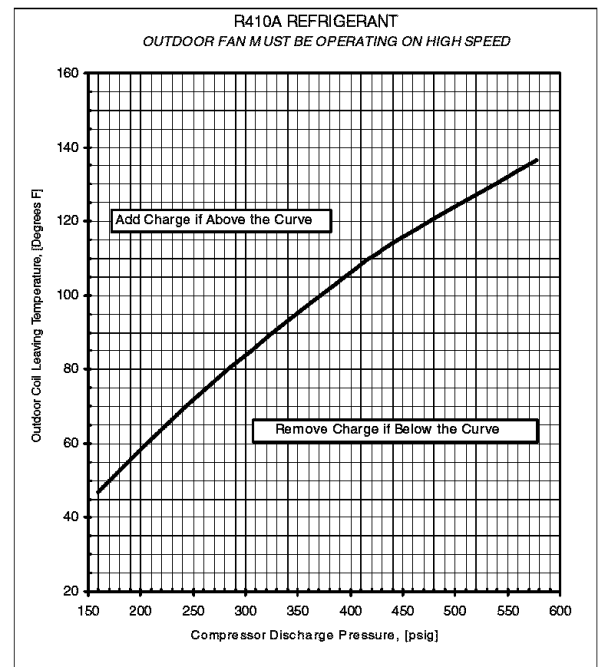

Fig. 34 — Charging Chart — 48PG06

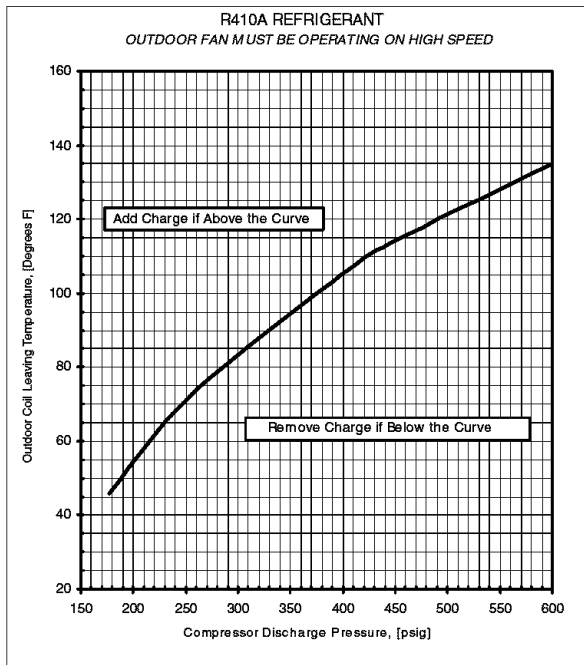

Fig. 35 — Charging Chart — 48PG07

PURON® REFRIGERANT — Puron refrigerant operates at 50 to 70 percent higher pressures than R-22. Be sure that servicing equipment and replacement components are designed to operate with Puron refrigerant. Do not mix with components that have been used with other refrigerants. Puron refrigerant, as with other HFCs, is only compatible with POE oils.

Recovery cylinder service pressure rating must be 400 psig. Puron systems should be charged with liquid refrigerant. Use a commercial-type metering device in the manifold hose. Manifold sets should be 750 psig high-side and 200 psig low-side with 520 psig low-side retard. Use hoses with 750 psig service pressure rating. Leak detectors should be designed to detect HFC refrigerant.

Gas Valve Adjustment — The gas valve opens and closes in response to the thermostat or limit control.

When power is supplied to valve terminals W2 (High Fire) and C1, the main valve opens to its preset position.

The regular factory setting is stamped on the valve body.

To adjust regulator:

1. Set unit at setting for no call for heat.
2. Turn main gas valve to OFF position.
3. Remove 1/8-in. pipe plug from manifold pressure tap connection. Install a suitable pressure-measuring device.
4. Set main gas valve to ON position.
5. Set thermostat at setting to call for heat.
6. Remove screw cap covering regulator adjustment screw (See Fig. 36).
7. Turn adjustment screw clockwise to increase pressure or counterclockwise to decrease pressure. The setting is 3.50 in. wg.
8. Once desired pressure is established, set unit setting for no call for heat, turn off main gas valve, remove pressure-measuring device, and replace 1/8-in. pipe plug and screw cap.

High Altitude — For high altitude applications greater than 2,000 ft the heat input rate should be reduced. The higher the altitude is above sea level, the less oxygen is in the air. See Table 35 for orifice sizing. A high altitude kit is available to convert unit for altitudes up to 7,000 ft.

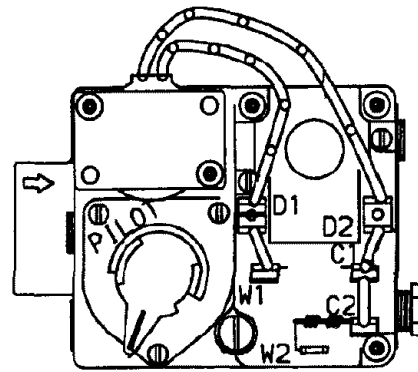

Fig. 36 — Gas Valve (48PG08-14 Shown)

Table 35 — Altitude Compensation*

ELEVATION (ft)	NATURAL GAS ORIFICE†	LP ORIFICE†
0-1,999	45	52
2,000	47	52
3,000	47	53
4,000	47	53
5,000	48	53
6,000	48	53
7,000	48	53
8,000	49	54
9,000	49	54
10,000	50	54
11,000	51	54
12,000	51	55
13,000	52	55
14,000	52	56

LEGEND

LP — Liquid Propane

*As the height above sea level increases, there is less oxygen per cubic foot of air. Therefore, heat input rate should be reduced at higher altitudes. Includes a 4% input reduction per each 1000 ft.

†Orifices available through your Carrier dealer.

LP (Liquid Propane) Gas Use — Base units are equipped with orifice sizes selected for natural gas use at elevations below 2000 ft. If LP fuel will be used, change the orifices according to Table 35 data. Manifold pressure is NOT changed when using LP fuel. Check per Start-Up section on page 20.

Main Burners — For all applications, main burners are factory set and should require no adjustment.

MAIN BURNER REMOVAL

1. Shut off (field-supplied) manual main gas valve.
2. Shut off power to unit.
3. Open gas section access door.
4. Disconnect gas piping from gas valve inlet.
5. Remove wires from gas valve.
6. Remove wires from rollout switch.
7. Remove sensor wire and ignitor cable from IGC board.
8. Remove 2 screws that hold the burner assembly to vestibule plate.
9. Rotate the burner/manifold assembly to the right, away from the flue extension and lift burner/manifold assembly out of unit.

CLEANING AND ADJUSTMENT

1. Remove burner rack from unit as described in Main Burner Removal section above.
2. Inspect burners, and if dirty, remove burners from rack. The two outer burners have the flame crossover closed off in order to prevent gas flow from exiting the sides of the burner assembly. To prevent ignition problems, make sure the outer burners are returned to their original position when done servicing.
3. Using a soft brush, clean burners and crossover port as required.
4. Adjust spark gap. See Fig. 37.

5. Reinstall burners on rack.
6. Reinstall burner rack as described above.

Filter Drier — Replace whenever refrigerant system is exposed to atmosphere. Only use factory specified liquid-line filter driers with working pressures no less than 650 psig. Do not install a suction-line filter drier in liquid line. A liquid-line filter drier designed for use with Puron® refrigerant is required on every unit.

Protective Devices

COMPRESSOR PROTECTION

High-Pressure Switch — If the high-pressure switch opens, the compressor will shut down. On 3-phase units, the compressor lockout (CLO) device will energize to block further compressor operation. The high-pressure switch will reset automatically as the refrigerant pressure drops below its reset level. On 3-phase units the CLO will remain energized until manually reset.

Low-Pressure Switch — If the low-pressure switch opens, the compressor will shut down. On 3-phase units, the compressor lockout (CLO) device will energize to block further compressor operation. The low-pressure switch will reset automatically as the refrigerant pressure rises above its reset level. On 3-phase units, the CLO will remain energized until manually reset.

Freeze Protection Switch — This switch is installed on each evaporator coil section to provide protection against continued unit operation with a frosted evaporator surface. If the freeze protection switch opens, the compressor on this circuit will shut down. On 3-phase units, the compressor lockout (CLO) device will energize to block further compressor operation. The freeze protection switch will reset as the evaporator tube temperature rises above its reset level. On 3-phase units, the CLO will remain energized until manually reset.

Compressor Lockout (CLO) Device (3-Phase Units Only) — The CLO prevents automatic recycling of the compressor as

safety controls reset. If the high-pressure switch, low-pressure switch or freeze protection switch opens, the CLO device will energize to block further compressor operation. To reset the CLO (after all safety switches have reset), either open the thermostat to remove the cooling demand signal (and then re-close) or cycle the control power in the unit.

Overcurrent — Each compressor has internal line break motor protection.

Overtemperature — Each compressor has an internal protector to protect it against excessively high discharge gas temperatures.

EVAPORATOR FAN MOTOR PROTECTION — Indoor fan motors are equipped with internal overcurrent and overtemperature protection. Protection devices reset automatically. Disconnect and lock out power when servicing motor. Do not bypass protective devices. Determine the cause and fix problem.

CONDENSER-FAN MOTOR PROTECTION — Each condenser-fan motor is internally protected against overtemperature.

Relief Devices — All units have relief devices to protect against damage from excessive pressures (i.e., fire). These devices protect the high and low side and are located at the suction line service port. Protect joint during brazing operations near joint.

Control Circuit, 24-V — Each control circuit is protected against overcurrent by a 3.2 amp circuit breaker. Breaker can be reset. If it trips, determine cause of trouble before resetting. See Fig. 38 and 39.

Replacement Parts — A complete list of replacement parts may be obtained from any Carrier distributor upon request.

Diagnostic LEDs — The IGC control board has a LED for diagnostic purposes.

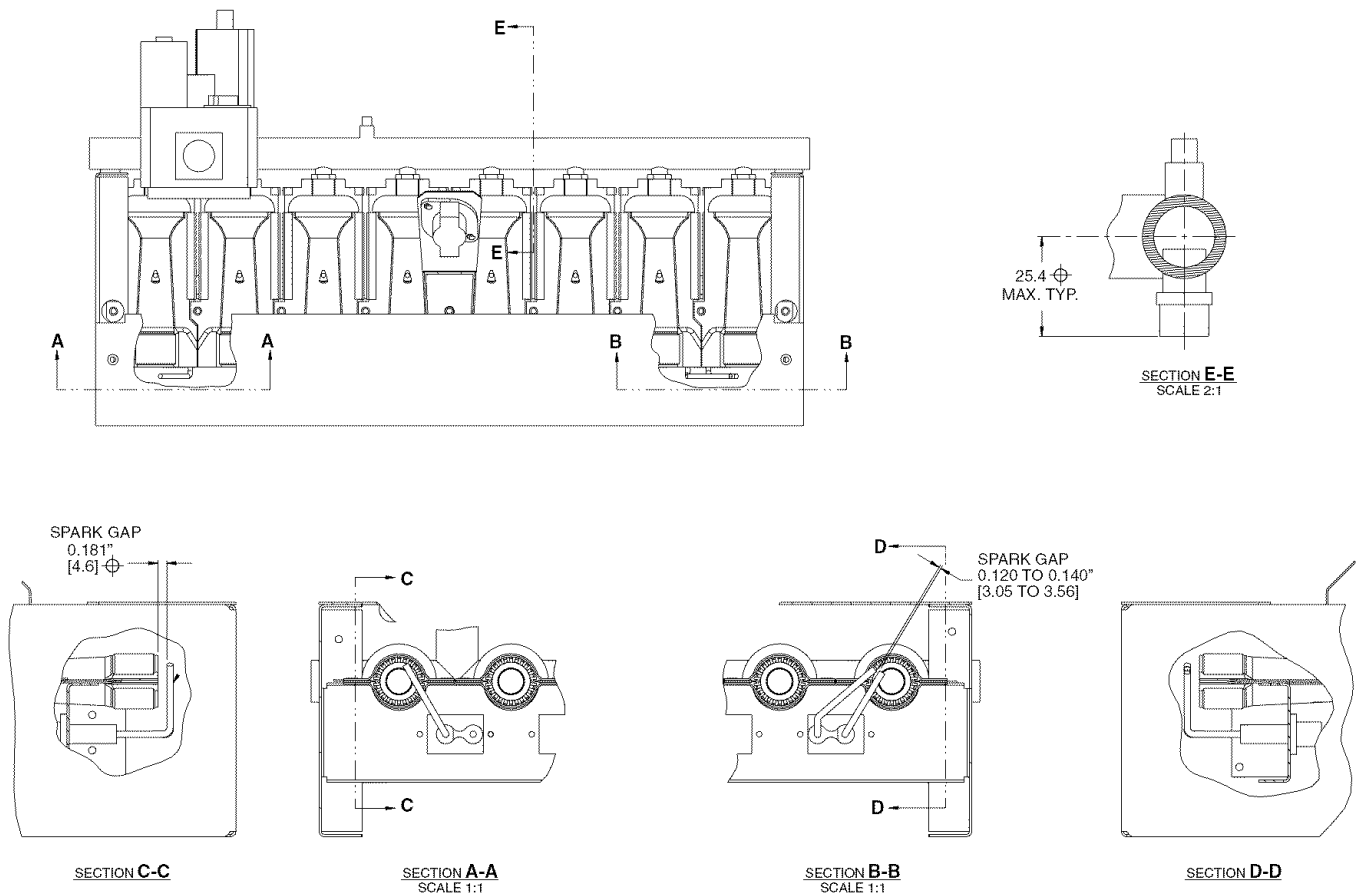

Fig. 41 — Spark Gap Adjustment

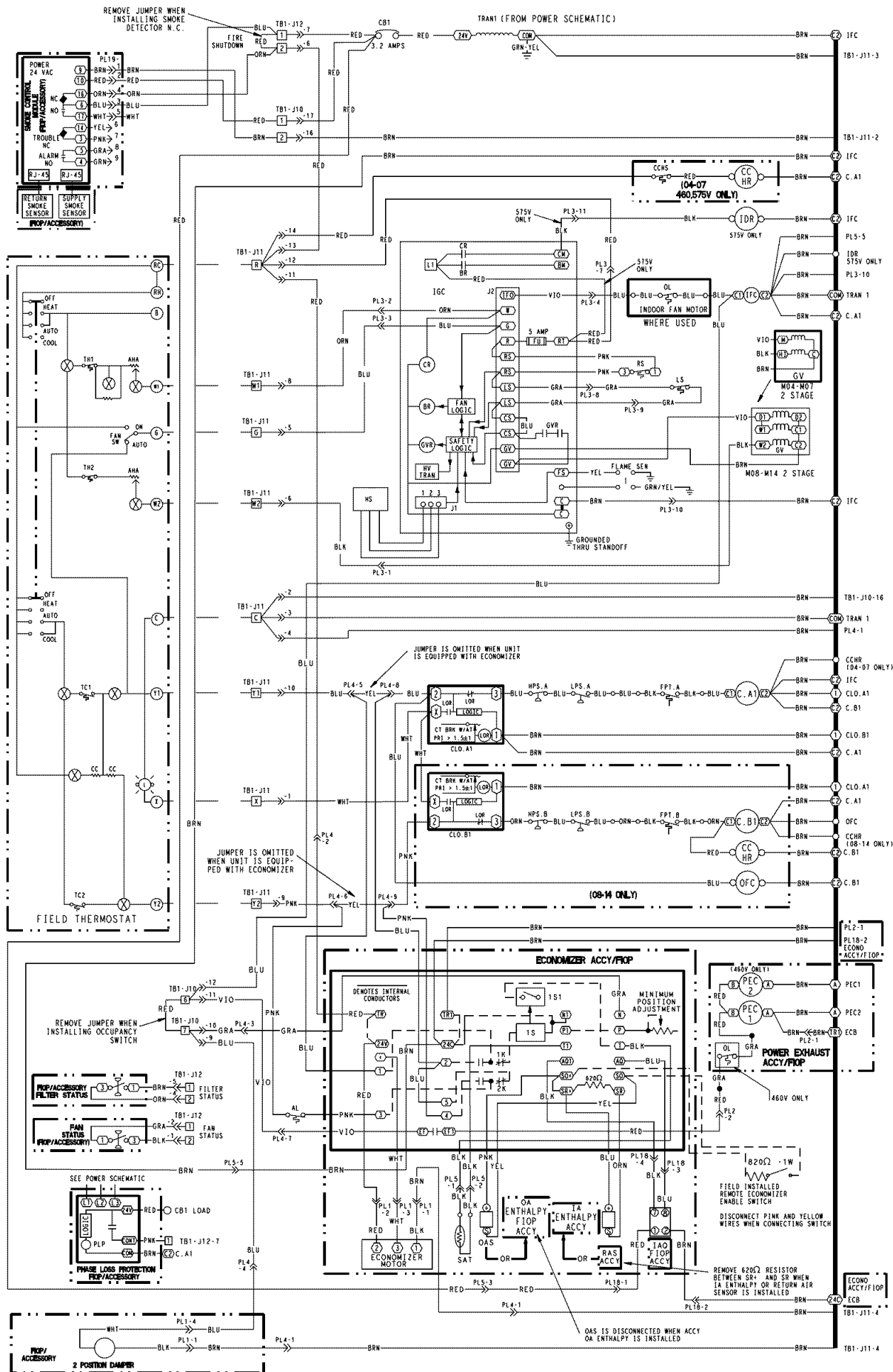
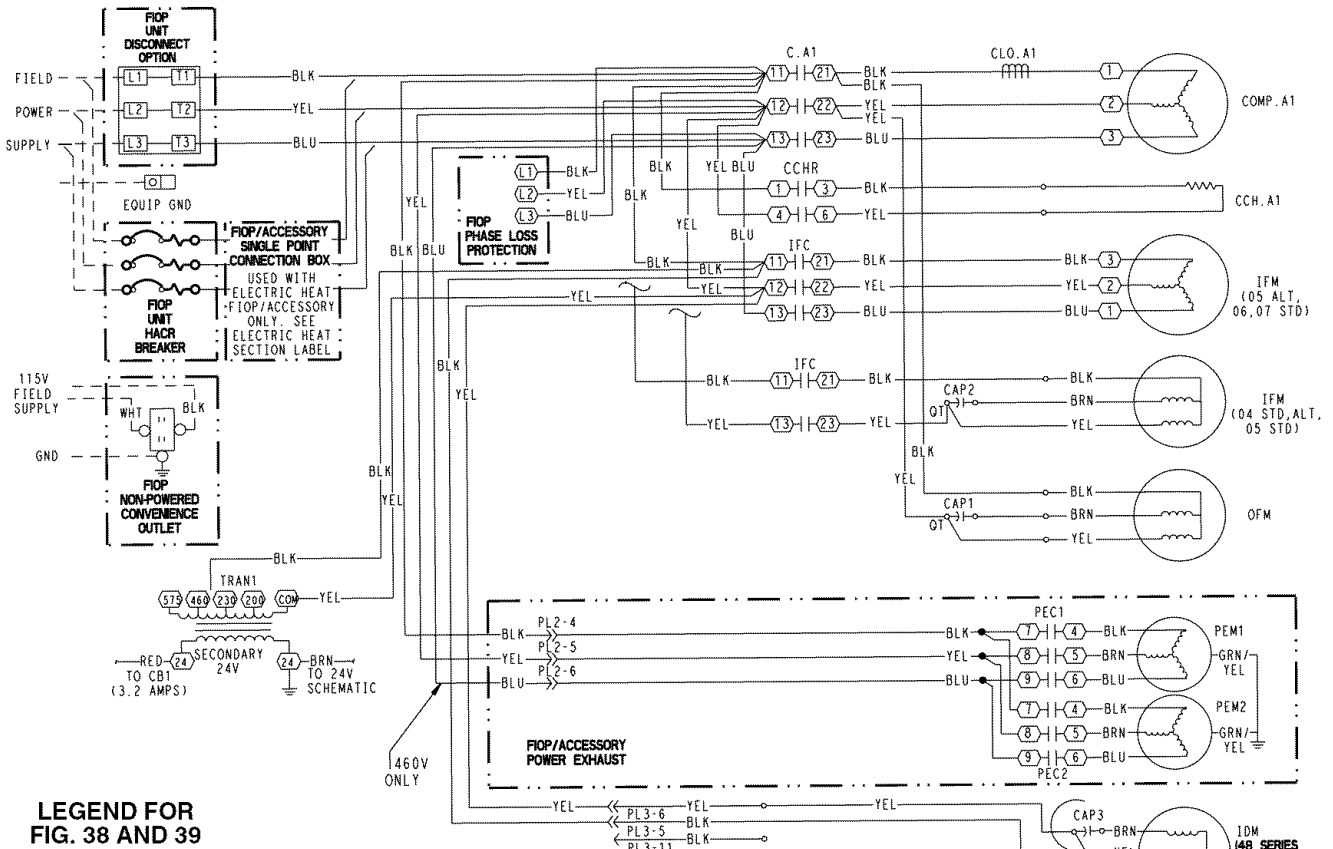

Fig. 38 — Typical Low Voltage Control Schematic



LEGEND FOR FIG. 38 AND 39

- AHA — Adjustable Heat Anticipator
- AL — Ambient Lockout
- A — Circuit A
- B — Circuit B
- C — Compressor Contactor
- CAP — Capacitor
- CB — Compressor Circuit Breaker
- CC — Cooling Compensator
- CCH — Crankcase Heater
- CCHR — Crankcase Heater Relay
- CCHS — Crankcase Heater Solenoid
- CLO — Compressor Lockout
- COMP — Compressor
- CT BRK — Circuit Breaker
- ECB — Economizer Control Board
- ECON — Economizer
- FIOP — Factory-Installed Option
- FPT — Freeze Protect Thermostat
- FS — Flame Sensor
- FU — Fuse
- GND — Ground
- GV — Gas Valve
- HACR — Heating, Air Conditioning, and Refrigeration
- HPS — High-Pressure Switch
- HS — Hall Effect Sensor
- I — Ignitor
- IAE — Indoor Air Enthalpy
- IAQ — Indoor Air Quality
- IDM — Induced-Draft Motor
- IFC — Indoor-Fan Contactor
- IFCB — Indoor-Fan Circuit Breaker
- IFM — Indoor-Fan Motor
- IGC — Integrated Gas Controller
- LOR — Lockout Relay
- LPS — Low-Pressure Switch
- LS — Limit Switch
- LSM — Mechanical Limit Switch
- OAE — Outdoor-Air Enthalpy
- OAS — Outdoor-Air Sensor
- OFC — Outdoor-Fan Contactor
- OFM — Outdoor-Fan Motor
- OL — Overload
- PEC — Power Exhaust Contactor
- PEM — Power Exhaust Motor
- PL — Plug
- PLP — Phase Loss Protection
- QT — Quadruple Terminal
- RAS — Return Air Sensor
- RS — Rollout Switch
- SAT — Supply-Air Temperature
- TB — Terminal Block
- TC — Thermostat-Cooling
- TH — Thermostat-Heating
- TRAN — Transformer
- W/AT — With Auxiliary Trip

- NOTES:**
1. IF ANY OF THE ORIGINAL WIRE FURNISHED MUST BE REPLACED, IT MUST BE REPLACED WITH TYPE 90°C OR ITS EQUIVALENT.
 2. THREE PHASE MOTORS ARE PROTECTED UNDER PRIMARY SINGLE PHASING CONDITIONS.
 3. USE COPPER CONDUCTORS ONLY.
 4. RED JUMPER WIRE MUST BE ADDED BETWEEN R AND W1 FOR SPACE TEMPERATURE MODE AND TEMPORARILY DURING SERVICE-TEST MODE WHEN THE HEATERS NEED TO OPERATE.
 5. TRAN1 AND 2 ARE WIRED FOR 230V ON 208/230V UNITS. IF UNIT IS TO BE RUN WITH 208V POWER SUPPLY, DISCONNECT BLK WIRE FROM 230V TERMINAL AND CONNECT TO 200V TERMINAL.

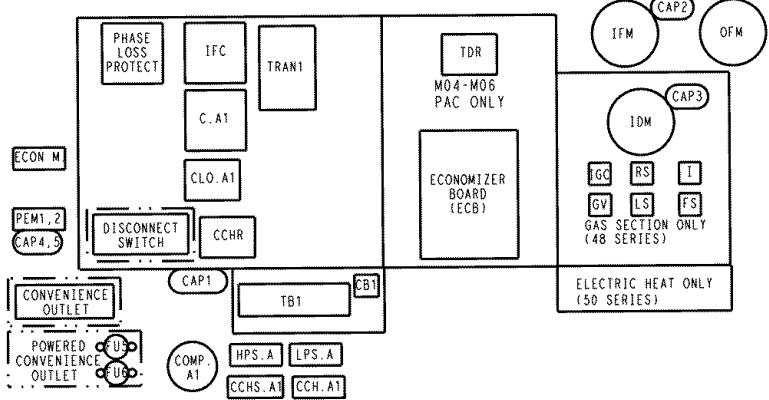
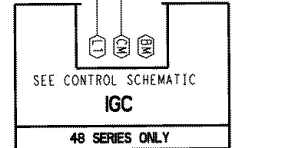
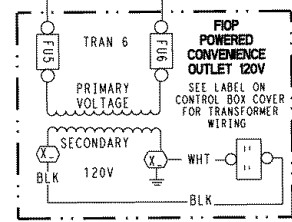

- THERMOSTAT/IGC MARKINGS**
- BM — Blower Motor
 - C — Common
 - CM — Combustion Motor
 - CS — Centrifugal Switch
 - G — Fan
 - IFO — Indoor Fan On
 - L1 — Line 1
 - R — Thermostat Power
 - RT — Power Supply
 - SS — Speed Sensor
 - W — Thermostat Heat
 - W1 — 1st Stage of Heating
 - W2 — 2nd Stage of Heating
 - X — Alarm Output
 - Y1 — 1st Stage of Cooling
 - Y2 — 2nd Stage of Cooling

Fig. 39 — Typical Power Schematic

TROUBLESHOOTING

Unit Troubleshooting — See Table 36 for unit cooling troubleshooting. See Tables 37 and 38 for unit heating troubleshooting.

Table 36 — Cooling Service Analysis

PROBLEM	CAUSE	REMEDY
Compressor and Condenser Fan Will Not Start.	Power failure.	Call power company.
	Fuse blown or circuit breaker tripped.	Replace fuse or reset circuit breaker.
	Defective thermostat, contactor, transformer, or control relay.	Replace component.
	Insufficient line voltage.	Determine cause and correct.
	Incorrect or faulty wiring.	Check wiring diagram and rewire correctly.
	Thermostat setting too high.	Lower thermostat setting below room temperature.
Compressor Will Not Start But Condenser Fan Runs.	Faulty wiring or loose connections in compressor circuit.	Check wiring and repair or replace.
	Compressor motor burned out, seized, or internal overload open.	Determine cause. Replace compressor.
	Defective run/start capacitor, overload, start relay.	Determine cause and replace.
	One leg of 3-phase power dead.	Replace fuse or reset circuit breaker. Determine cause.
Compressor Cycles (Other Than Normally Satisfying Thermostat).	Refrigerant overcharge or undercharge.	Recover refrigerant, evacuate system, and recharge to nameplate.
	Defective compressor.	Replace and determine cause.
	Insufficient line voltage.	Determine cause and correct.
	Blocked condenser.	Determine cause and correct.
	Defective run/start capacitor, overload, or start relay.	Determine cause and replace.
	Defective thermostat.	Replace thermostat.
	Faulty condenser-fan motor or capacitor.	Replace.
	Restriction in refrigerant system.	Locate restriction and remove.
Compressor Operates Continuously.	Dirty air filter.	Replace filter.
	Unit undersized for load.	Decrease load or increase unit size.
	Thermostat set too low.	Reset thermostat.
	Low refrigerant charge.	Locate leak, repair, and recharge.
	Leaking valves in compressor.	Replace compressor.
	Air in system.	Recover refrigerant, evacuate system, and recharge.
	Condenser coil dirty or restricted.	Clean coil or remove restriction.
Excessive Head Pressure.	Dirty air filter.	Replace filter.
	Dirty condenser coil.	Clean coil.
	Refrigerant overcharged.	Recover excess refrigerant.
	Air in system.	Recover refrigerant, evacuate system, and recharge.
	Condenser air restricted or air short-cycling.	Determine cause and correct.
Head Pressure Too Low.	Low refrigerant charge.	Check for leaks, repair, and recharge.
	Compressor valves leaking.	Replace compressor.
	Restriction in liquid tube.	Remove restriction.
Excessive Suction Pressure.	High heat load.	Check for source and eliminate.
	Compressor valves leaking.	Replace compressor.
	Refrigerant overcharged.	Recover excess refrigerant.
Suction Pressure Too Low.	Dirty air filter.	Replace filter.
	Low refrigerant charge.	Check for leaks, repair, and recharge.
	Metering device or low side restricted.	Remove source of restriction.
	Insufficient evaporator airflow.	Increase air quantity. Check filter and replace if necessary.
	Temperature too low in conditioned area.	Reset thermostat.
	Outdoor ambient below 25 F.	Install low-ambient kit.
Evaporator Fan Will Not Shut Off.	Time off delay not finished.	Wait for 30-second off delay.

Table 37 — Heating Service Analysis

PROBLEM	CAUSE	REMEDY
Burners Will Not Ignite.	Misaligned spark electrodes.	Check flame ignition and sensor electrode positioning. Adjust as needed.
	No gas at main burners.	Check gas line for air purge as necessary. After purging gas line of air, allow gas to dissipate for at least 5 minutes before attempting to relight unit. Check gas valve.
	Water in gas line.	Drain water and install drip leg to trap water.
	No power to furnace.	Check power supply, fuses, wiring, and circuit breaker.
	No 24 v power supply to control circuit.	Check transformer. Transformers with internal overcurrent protection require a cool-down period before resetting. Check 24-v circuit breaker; reset if necessary.
	Miswired or loose connections.	Check all wiring and wirenut connections.
	Burned-out heat anticipator in thermostat.	Replace thermostat.
	Broken thermostat wires.	Run continuity check. Replace wires, if necessary.
Inadequate Heating.	Dirty air filter.	Clean or replace filter as necessary.
	Gas input to unit too low.	Check gas pressure at manifold. Clock gas meter for input. If too low, increase manifold pressure or replace with correct orifices.
	Unit undersized for application.	Replace with proper unit or add additional unit.
	Restricted airflow.	Clean filter, replace filter, or remove any restrictions.
	Blower speed too low.	Use high speed tap, increase fan speed, or install optional blower, as suitable for individual units. Adjust pulley.
	Limit switch cycles main burners.	Check rotation of blower, thermostat heat anticipator settings, and temperature rise of unit. Adjust as needed.
	Too much outdoor air.	Adjust minimum position. Check economizer operation.
Poor Flame Characteristics.	Incomplete combustion (lack of combustion air) results in: Aldehyde odors, CO (carbon monoxide), sooting flame, or floating flame.	Check all screws around flue outlets and burner compartment. Tighten as necessary.
		Cracked heat exchanger. Replace.
		Overfired unit — reduce input, change orifices, or adjust gas line or manifold pressure.
		Check vent for restriction. Clean as necessary.
		Check orifice to burner alignment.
Burners Will Not Turn Off.	Unit is locked into Heating mode for a one minute minimum.	Wait until mandatory one-minute time period has elapsed or reset power to unit.

Table 38 — IGC Board LED Alarm Codes

LED FLASH CODE	DESCRIPTION	ACTION TAKEN BY CONTROL	RESET METHOD	PROBABLE CAUSE
On	Normal Operation	—	—	—
Off	Hardware Failure	No gas heating.	—	Loss of power to the IGC. Check 5 amp fuse on IGC, power to unit, 24 v circuit breaker, transformer, and wiring to the IGC.
1 Flash	Indoor Fan On/Off Delay Modified	5 seconds subtracted from On delay. 5 seconds added to Off delay (3 min max).	Power reset.	High temperature limit switch opens during heat exchanger warm-up period before fan-on delay expires. High temperature limit switch opens within 10 minutes of heat call (W) Off. See Limit Switch Fault.
2 Flashes	Limit Switch Fault	Gas valve and igniter Off. Indoor fan and inducer On.	Limit switch closed, or heat call (W) Off.	High temperature limit switch is open. Check the operation of the indoor (evaporator) fan motor. Ensure that the supply-air temperature rise is within the range on the unit nameplate. Check wiring and limit switch operation.
3 Flashes	Flame Sense Fault	Indoor fan and inducer On.	Flame sense normal. Power reset for LED reset.	The IGC sensed a flame when the gas valve should be closed. Check wiring, flame sensor, and gas valve operation.
4 Flashes	Four Consecutive Limit Switch Fault	No gas heating.	Heat call (W) Off. Power reset for LED reset.	4 consecutive limit switch faults within a single call for heat. See Limit Switch Fault.
5 Flashes	Ignition Fault	No gas heating.	Heat call (W) Off. Power reset for LED reset.	Unit unsuccessfully attempted ignition for 15 minutes. Check igniter and flame sensor electrode spacing, gaps, etc. Check flame sense and igniter wiring. Check gas valve operation and gas supply.
6 Flashes	Induced Draft Motor Fault	If heat off: no gas heating. If heat on: gas valve Off and inducer On.	Inducer sense normal, or heat call (W) Off.	Inducer sense On when heat call Off, or inducer sense Off when heat call On. Check wiring, voltage, and operation of IGC motor. Check speed sensor wiring to IGC.
7 Flashes	Rollout Switch Lockout	Gas valve and igniter Off. Indoor fan and inducer On.	Power reset.	Rollout switch has opened. Check gas valve operation. Check induced-draft blower wheel is properly secured to motor shaft.
8 Flashes	Internal Control Lockout	No gas heating.	Power reset.	IGC has sensed internal hardware or software error. If fault is not cleared by resetting 24 v power, replace the IGC.
9 Flashes	Temporary Software Lockout	No gas heating.	1 hour auto reset, or power reset.	Electrical interference is disrupting the IGC software.

LEGEND
IGC — Integrated Gas Unit Control
LED — Light-Emitting Diode

NOTES:
 1. There is a 3-second pause between alarm code displays.
 2. If more than one alarm code exists, all applicable alarm codes will be displayed in numerical sequence.
 3. Alarm codes on the IGC will be lost if power to the unit is interrupted.

EconoMiSer IV Troubleshooting

ECONOMISER IV PREPARATION — This procedure is used to prepare the EconoMiSer IV for troubleshooting. No troubleshooting or testing is done by performing the following procedure.

NOTE: This procedure requires a 9-v battery, 1.2 kilo-ohm resistor, and a 5.6 kilo-ohm resistor which are not supplied with the EconoMiSer IV.

IMPORTANT: Be sure to record the positions of all potentiometers before starting troubleshooting.

1. Disconnect power at TR and TR1. All LEDs should be off. Exhaust fan contacts should be open.
2. Disconnect device at P and P1.
3. Jumper P to P1.
4. Disconnect wires at T and T1. Place 5.6 kilo-ohm resistor across T and T1.
5. Jumper TR to 1.
6. Jumper TR to N.
7. If connected, remove sensor from terminals S_O and +. Connect 1.2 kilo-ohm 4074EJM checkout resistor across terminals S_O and +.
8. Put 620-ohm resistor across terminals S_R and +.
9. Set minimum position, DCV set point, and exhaust potentiometers fully CCW (counterclockwise).
10. Set DCV maximum position potentiometer fully CW (clockwise).
11. Set enthalpy potentiometer to D.
12. Apply power (24 vac) to terminals TR and TR1.

DIFFERENTIAL ENTHALPY — To check differential enthalpy:

1. Make sure EconoMiSer IV preparation procedure has been performed.
2. Place 620-ohm resistor across S_O and +.
3. Place 1.2 kilo-ohm resistor across S_R and +. The Free Cool LED should be lit.
4. Remove 620-ohm resistor across S_O and +. The Free Cool LED should turn off.
5. Return EconoMiSer IV settings and wiring to normal after completing troubleshooting.

SINGLE ENTHALPY — To check single enthalpy:

1. Make sure EconoMiSer IV preparation procedure has been performed.
2. Set the enthalpy potentiometer to A (fully CCW). The Free Cool LED should be lit.
3. Set the enthalpy potentiometer to D (fully CW). The Free Cool LED should turn off.
4. Return EconoMiSer IV settings and wiring to normal after completing troubleshooting.

DCV (DEMAND CONTROLLED VENTILATION) AND POWER EXHAUST — To check DCV and power exhaust:

1. Make sure EconoMiSer IV preparation procedure has been performed.
2. Ensure terminals AQ and AQ1 are open. The LED for both DCV and Exhaust should be off. The actuator should be fully closed.
3. Connect a 9-v battery to AQ (positive node) and AQ1 (negative node). The LED for both DCV and Exhaust should turn on. The actuator should drive to between 90 and 95% open.
4. Turn the Exhaust potentiometer CW until the Exhaust LED turns off. The LED should turn off when the

potentiometer is approximately 90%. The actuator should remain in position.

5. Turn the DCV set point potentiometer CW until the DCV LED turns off. The DCV LED should turn off when the potentiometer is approximately 9 v. The actuator should drive fully closed.
6. Turn the DCV and Exhaust potentiometers CCW until the Exhaust LED turns on. The exhaust contacts will close 30 to 120 seconds after the Exhaust LED turns on.
7. Return EconoMiSer IV settings and wiring to normal after completing troubleshooting.

DCV MINIMUM AND MAXIMUM POSITION — To check the DCV minimum and maximum position:

1. Make sure EconoMiSer IV preparation procedure has been performed.
2. Connect a 9-v battery to AQ (positive node) and AQ1 (negative node). The DCV LED should turn on. The actuator should drive to between 90 and 95% open.
3. Turn the DCV Maximum Position potentiometer to midpoint. The actuator should drive to between 20 and 80% open.
4. Turn the DCV Maximum Position potentiometer to fully CCW. The actuator should drive fully closed.
5. Turn the Minimum Position potentiometer to midpoint. The actuator should drive to between 20 and 80% open.
6. Turn the Minimum Position Potentiometer fully CW. The actuator should drive fully open.
7. Remove the jumper from TR and N. The actuator should drive fully closed.
8. Return EconoMiSer IV settings and wiring to normal after completing troubleshooting.

MIXED AIR INPUT — To check mixed air input:

1. Make sure EconoMiSer IV preparation procedure has been performed.
2. Set the Enthalpy potentiometer to A. The Free Cool LED turns on. The actuator should drive between 20 to 80% open.
3. Remove the 5.6 kilo-ohm resistor and jumper T to T1. The actuator should drive fully open.
4. Remove the jumper across T and T1. The actuator should drive fully closed.
5. Return EconoMiSer IV settings and wiring to normal after completing troubleshooting.

ECONOMISER IV TROUBLESHOOTING COMPLETION — This procedure is used to return the EconoMiSer IV to operation. No troubleshooting or testing is done by performing the following procedure.

1. Disconnect power at TR and TR1.
2. Set enthalpy potentiometer to previous setting.
3. Set DCV maximum position potentiometer to previous setting.
4. Set minimum position, DCV set point, and exhaust potentiometers to previous settings.
5. Remove 620-ohm resistor from terminals S_R and +.
6. Remove 1.2 kilo-ohm checkout resistor from terminals S_O and +. If used, reconnect sensor from terminals S_O and +.
7. Remove jumper from TR to N.
8. Remove jumper from TR to 1.
9. Remove 5.6 kilo-ohm resistor from T and T1. Reconnect wires at T and T1.
10. Remove jumper from P to P1. Reconnect device at P and P1.
11. Apply power (24 vac) to terminals TR and TR1.

Phase Loss Protection — The phase loss protection option will monitor the three-phase electrical system to provide phase reversal and phase loss protection.

PHASE REVERSAL PROTECTION — If the control senses an incorrect phase relationship, the relay (K1) will be de-energized (opening its contact). If the phase relationship is correct, the relay will be energized. The control has a self-bypass function after a pre-set time. If the control determines that the three phases stay in a correct relationship for 10 consecutive minutes, the relay will stay energized regardless of the phase sequence of three inputs as long as 24-vac control voltage is applied. This self-bypass function will be reset if all three phases are restored in a phase loss event.

PHASE LOSS PROTECTION — If the reverse rotation board senses any one of the three phase inputs has no AC voltage, the relay will be deenergized (opening its contact). This

protection is always active as long as 24-vac control voltage is applied, and is not affected by the self-bypass function of the phase sequence monitoring function. However, in the event of phase loss, the relay will be re-energized only if all three phases are restored and the three phases are in the correct sequence.

A red LED is provided to indicate the function of the board. See the table below.

LED STATUS	FUNCTION
On Continuously	Relay contact closed (normal operation).
Blinking	Relay contact open (phase loss or phase reversal has occurred) — No power will be supplied to the control system.
Off	24 vac control power not present (off).

UNIT START-UP CHECKLIST

MODEL NO.: _____

SERIAL NO.: _____

DATE: _____

TECHNICIAN: _____

I. PRE-START-UP:

- VERIFY THAT ALL PACKING MATERIALS HAVE BEEN REMOVED FROM UNIT
- VERIFY INSTALLATION OF OUTDOOR AIR HOOD
- VERIFY INSTALLATION OF FLUE EXHAUST AND INLET HOOD
- VERIFY THAT CONDENSATE CONNECTION IS INSTALLED PER INSTRUCTIONS
- VERIFY THAT ALL ELECTRICAL CONNECTIONS AND TERMINALS ARE TIGHT
- VERIFY GAS PRESSURE TO UNIT GAS VALVE IS WITHIN SPECIFIED RANGE
- CHECK GAS PIPING FOR LEAKS
- CHECK THAT INDOOR-AIR FILTERS ARE CLEAN AND IN PLACE
- CHECK THAT OUTDOOR AIR INLET SCREENS ARE IN PLACE
- VERIFY THAT UNIT IS LEVEL
- CHECK FAN WHEEL AND PROPELLER FOR LOCATION IN HOUSING/ORIFICE, AND VERIFY SETSCREW IS TIGHT
- VERIFY THAT FAN SHEAVES ARE ALIGNED AND BELTS ARE PROPERLY TENSIONED
- VERIFY THAT SCROLL COMPRESSORS ARE ROTATING IN THE CORRECT DIRECTION
- VERIFY INSTALLATION OF THERMOSTAT
- VERIFY THAT CRANKCASE HEATERS HAVE BEEN ENERGIZED FOR AT LEAST 24 HOURS

II. START-UP

ELECTRICAL

SUPPLY VOLTAGE L1-L2 _____ L2-L3 _____ L3-L1 _____

COMPRESSOR AMPS — COMPRESSOR A1 L1 _____ L2 _____ L3 _____

SUPPLY FAN AMPS _____ L1 _____ L2 _____ L3 _____

TEMPERATURES

OUTDOOR-AIR TEMPERATURE _____ F DB (Dry Bulb)

RETURN-AIR TEMPERATURE _____ F DB _____ F WB (Wet Bulb)

COOLING SUPPLY AIR _____ F

GAS HEAT SUPPLY AIR _____ F

PRESSURES

GAS INLET PRESSURE _____ IN. WG

GAS MANIFOLD PRESSURE STAGE NO. 1 _____ IN. WG STAGE NO. 2 _____ IN. WG

REFRIGERANT SUCTION CIRCUIT A _____ PSIG

REFRIGERANT DISCHARGE CIRCUIT A _____ PSIG

- VERIFY REFRIGERANT CHARGE USING CHARGING CHARTS ON PAGES 41 AND 42

GENERAL

- ECONOMIZER MINIMUM VENT AND CHANGEOVER SETTINGS TO JOB REQUIREMENTS

CUT ALONG DOTTED LINE

CUT ALONG DOTTED LINE