

KSALA0601AAA
KSALA0701AAA

MotorMaster® — Low Ambient Controller
for Residential Split System Applications

Installation Instructions

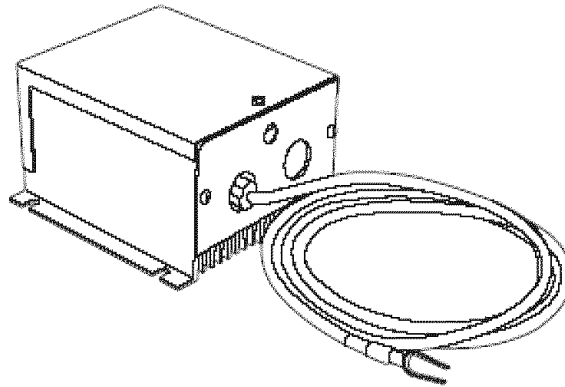

A93157

Fig. 1 - MotorMaster® Low Ambient Controller

NOTE: Read the entire instruction manual before starting the installation.

SAFETY CONSIDERATIONS

Improper installation, adjustment, alteration, service, maintenance, or use can cause explosion, fire, electrical shock, or other conditions which may cause death, personal injury, or property damage. Consult a qualified installer, service agency, or your distributor or branch for information or assistance. The qualified installer or agency must use factory-authorized kits or accessories when modifying this product. Refer to the individual instructions packaged with the kits or accessories when installing. Follow all safety codes. Wear safety glasses, protective clothing, and work gloves. Use quenching cloth for brazing operations. Have fire extinguisher available. Read these instructions thoroughly and follow all warnings or cautions included in literature and attached to the unit. Consult local building codes and National Electrical Code (NEC) for special requirements.

Recognize safety information. This is the safety-alert symbol . When you see this symbol on the unit and in instructions or manuals, be alert to the potential for personal injury.

Understand the signal words DANGER, WARNING, and CAUTION. These words are used with the safety-alert symbol. DANGER identifies the most serious hazards which **will** result in severe personal injury or death. WARNING signifies hazards which **could** result in personal injury or death. CAUTION is used to identify unsafe practices which **may** result in minor personal injury or product and property damage. NOTE is used to highlight suggestions which **will** result in enhanced installation, reliability, or operation.

WARNING

ELECTRICAL OPERATION HAZARD

Failure to follow this warning could result in personal injury or death.

Before installing, modifying, or servicing system, main electrical disconnect switch must be in the OFF position. There may be more than one disconnect switch. Lock out and tag switch with a suitable warning label.

INTRODUCTION

These instructions cover installation of MotorMaster® Part No. KSALA0601AAA and KSALA0701AAA on all residential single-speed air conditioners and heat pumps. The device is designed to control outdoor fan motor speed under low outdoor temperature conditions. A fan motor with ball bearings is required. The control is available in two models. Part No. KSALA0601AAA is rated for 208/230-1-60, and Part No. KSALA0701AAA is rated for 460-1-60. Other accessories may be required. Refer to the Required Unit Changes section of this document for details.

DESCRIPTION AND USAGE

The MotorMaster® is a fan speed control device activated by a temperature sensor. It is specifically designed to control condenser fan motor speed in response to the saturated condensing temperature during operation in cooling mode only. For outdoor temperatures down to -20°F, it maintains condensing temperature at 100°F ± 10°F. (See Fig. 1.)

The mounting control consists of a solid-state circuit on a printed circuit board in an aluminum extrusion, and a sensor assembly to be mounted to a return bend on the unit's condenser coil. A wire from the sensor is connected to the circuit board in the control box.

Parts necessary for mounting control and sensor assembly are included in the kit. Either assembly can be replaced independently of the other. If any damage to the printed circuit board or components is observed when unpacking control assembly, return for replacement.

The MotorMaster® maintains proper condensing temperature at any ambient temperature down to -20°F. No field adjustments or calibrations are required.

The following must be observed:

- If special fan motors or other accessories are required, install where necessary.
- Measure unit power supply voltage. It must meet minimum voltage specified on unit rating plate and match voltage rating of MotorMaster®.
- Make sure all units are modified for winter start control when needed.
- Check that control location is as specified.
- Check that sensor location is as specified.
- Make sure that sensor wiring routing is as specified.
- Make sure wind baffles are installed only if required.
- For heat pump units, make sure isolation relay is available.

INSTALLATION

⚠ CAUTION

UNIT DAMAGE HAZARD

Failure to follow this caution may result in unit damage.

Exercise extreme caution when drilling holes. Do not puncture coil and/or tubing.

PROCEDURE 1 — MOUNTING CONTROL ASSEMBLY

1. Make sure all power to unit is turned off

⚠ WARNING

ELECTRICAL OPERATION HAZARD

Failure to follow this warning could result in personal injury or death.

Before installing or servicing system, always turn off main power to system. There may be more than one disconnect switch.

2. Determine location for control assembly. (See Fig. 2.) Remove template from back of this instruction and tape to panel. Drill pilot holes as indicated. When mounting to service panel, drill two holes, 5/32-in. (0.156 in.) diameter, 1 in. away from panel edge as shown. (See Fig. 2.)
3. To ensure electrical ground with condensing unit, insert star lockwashers under head of screws. Fasten control assembly to unit with four No. 10 sheet metal screws provided. If wind baffles are used, ensure control has a continuous ground path to equipment ground. If control is mounted independent of unit, ensure an adequate ground path is maintained. All wiring must conform to NEC and/or local code.

NOTE: When properly positioned (mounted vertically with leads protruding from bottom of control), control is weather tight.

PROCEDURE 2 — MOUNTING SENSOR

Mount sensor on a specified condenser coil return bend as shown in Fig. 3.

IMPORTANT: The sensor assembly is delicate. Handle with care.

4. Route sensor wire through bottom knockout on service panel and over to outside row of coil (left side), taking care not to disturb tubing.
5. Secure sensor on coil return bend with the No. 4-40 screw and nut supplied with kit as shown in Fig. 4.
6. Bind unused wire and secure it near sensor or next to control.
7. Protect sensor wire from physical damage or wind movement where necessary.

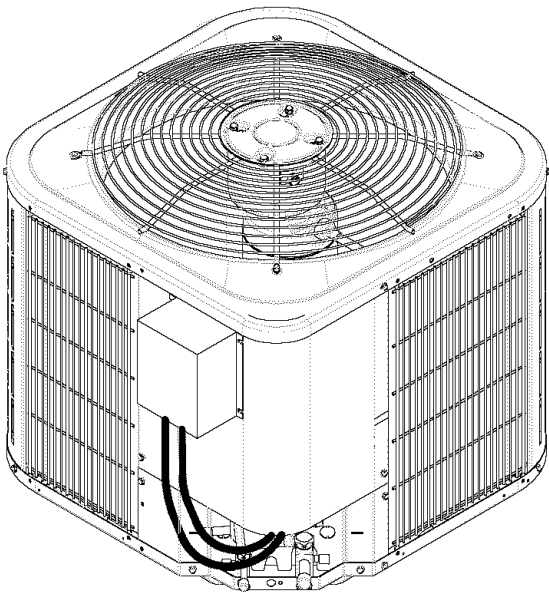

Bryant – Legacy – RNC / Legacy Models

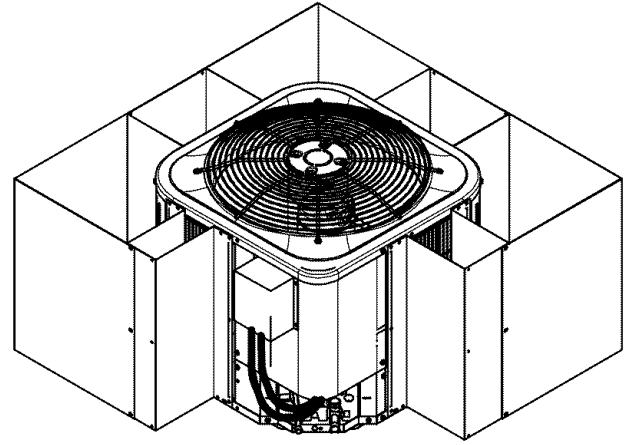

Bryant – Legacy – RNC / Legacy Models

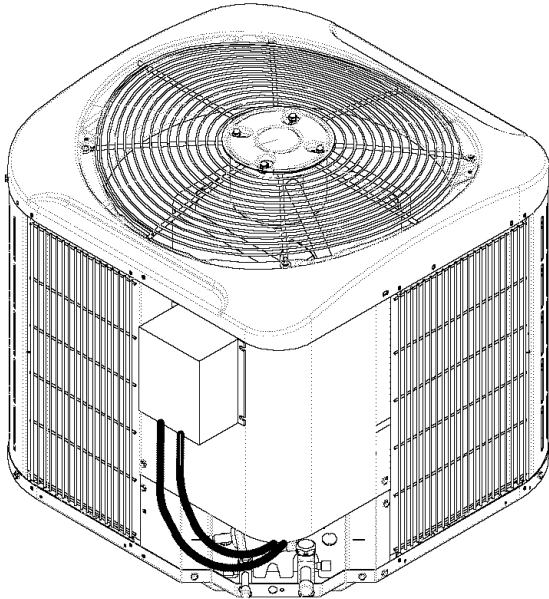

Carrier – Base / Comfort Series Models

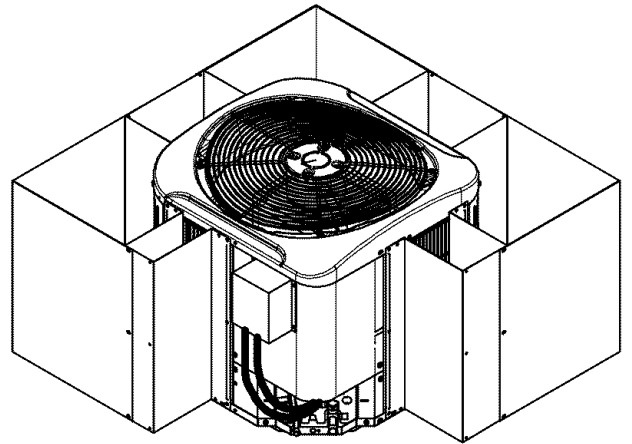

Carrier – Base / Comfort Series Models

Fig. 2 - Control Mounting

A06439

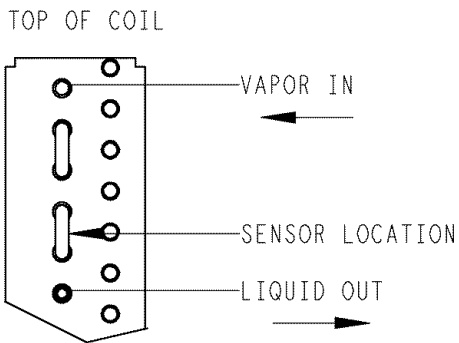
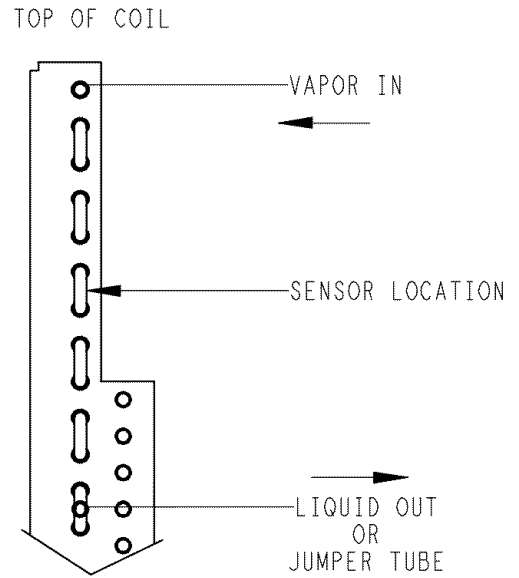
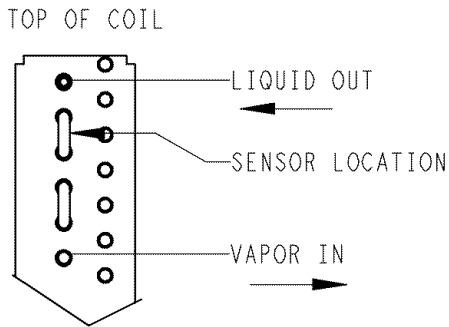
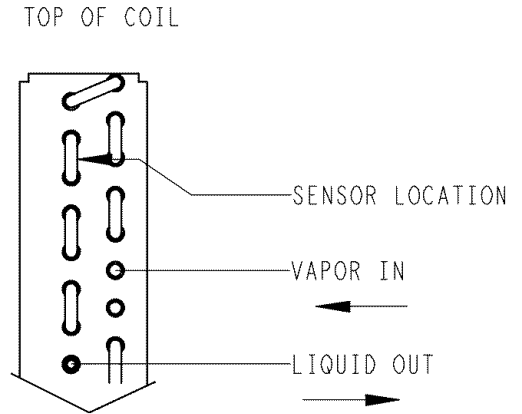
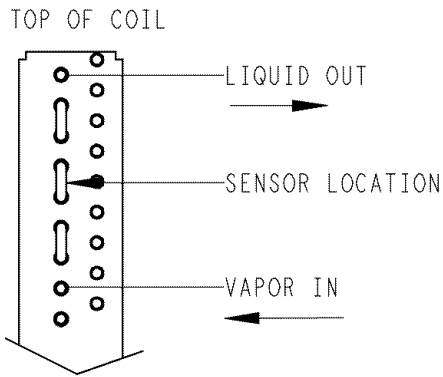
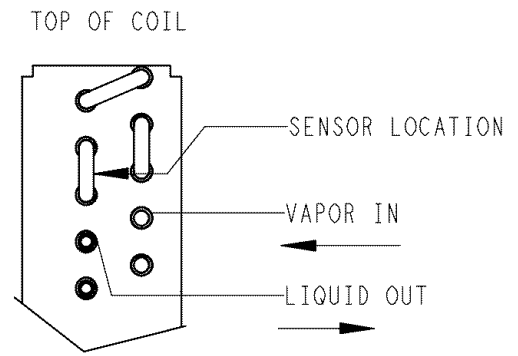
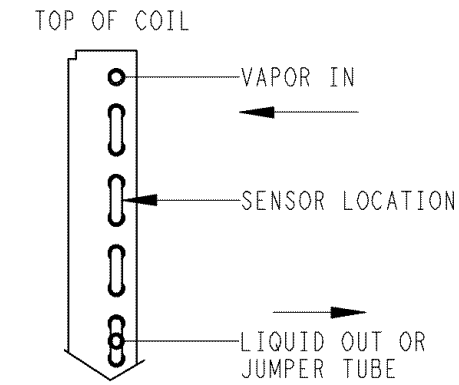

Fig. 3 - Sensor Location on Return End of Coil

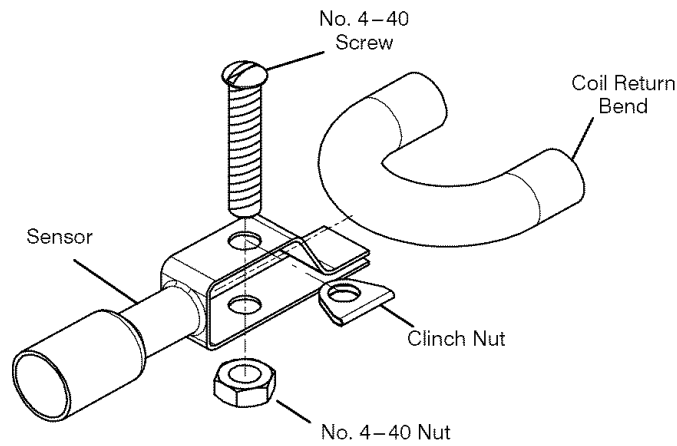

Fig. 4 - MotorMaster® Sensor

A93163

REQUIRED UNIT CHANGES

This section explains the changes required to equipment when MotorMaster® is applied. Use this section in conjunction with appropriate wind baffle figures and tables at rear of instruction. A ball bearing fan motor is required with this control.

PROCEDURE 1 — CONDENSING UNITS

A. Outdoor Fan Motor

Consult presale literature for outdoor fan motor change.

B. Crankcase Heater

Required on all applications where MotorMaster® is used. If not already installed, consult presale literature for required crankcase heater kit.

C. Hard Start Assist Kit (Capacitor and Relay)

Required on all single-phase applications where MotorMaster® is used. If not already installed, consult presale literature for required start kit.

D. Winter Start Control

Must be used where low evaporator temperatures or nuisance tripping of low-pressure switch may be encountered. Winter start control Part No. KAAWS0101AAA must be wired in parallel with low-pressure switch. (See Fig. 5.) This allows a delay of approximately 3 minutes before low-pressure switch becomes a part of control circuit.

NOTE: It is REQUIRED that evaporator freeze thermostat Part No. KAAFT0101AAA be attached to vapor tube near evaporator coil to prevent coil freezing. Wire thermostat in series with 24-v contactor coil. (See Fig. 6.)

E. Wind Baffles

Use only in installations where high winds are prevalent to prevent cross currents from causing abnormal control operation. For construction, refer to appropriate wind baffle figures and tables at rear of this instruction.

NOTE: When wind baffles are used, raising unit off of mounting pad with 4-in. support feet or unit risers is REQUIRED. This provides better airflow for moderate and high ambient temperatures.

F. Wiring

MotorMaster® must be wired in series with fan motor. (See Fig. 7.) Power wiring must comply with all local codes and NEC requirements.

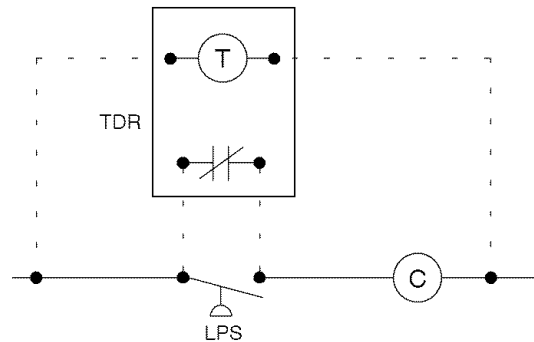

LPS LOW-PRESSURE SWITCH
 C CONTACTOR COIL
 TDR TIME DELAY RELAY
 T TIME DELAY RELAY COIL

— FACTORY WIRING
 - - - FIELD WIRING

Fig. 5 - Winter Start Control

A93165

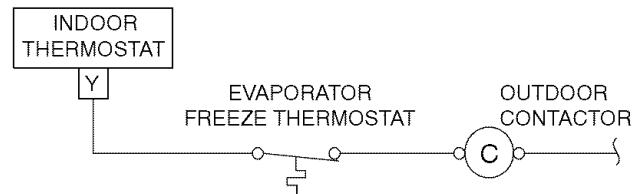

Fig. 6 - Evaporator Freeze Thermostat Wiring

A97511

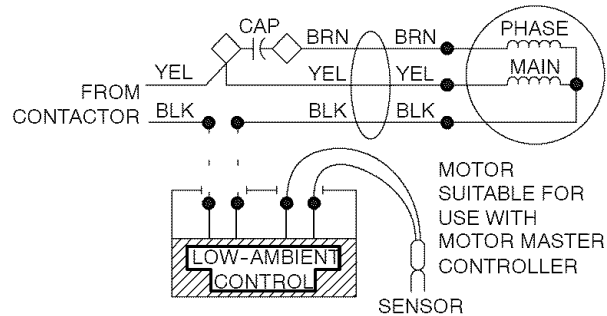

Fig. 7 - Power Wiring for 208-v, 230-v, and 460-v Condensing Units

A03225

PROCEDURE 2 — HEAT PUMPS

A. Outdoor Fan Motor

Consult presale literature for outdoor fan motor change.

B. Crankcase Heater

Required on all applications where MotorMaster® is used. If not already installed, consult presale literature for required crankcase heater.

C. Hard Start Assist Kit (Capacitor and Relay)

Required on all single-phase applications where MotorMaster® is used. If not already installed, consult presale literature for required accessory start kit.

NOTE: It is REQUIRED that evaporator freeze thermostat Part No. KAAFT0101AAA be applied to the evaporator coil to prevent coil freezing.

Wire thermostat in series with 24-v contactor coil. (See Fig. 6.)

D. Wind Baffles

Use only in installations where high winds are prevalent to prevent cross currents from causing abnormal control operation. For construction, refer to appropriate wind baffle figures and tables at rear of instruction

NOTE: When wind baffles are used, raising unit off of mounting pad with 4-in. support feet or unit risers is REQUIRED. This provides better airflow for moderate and high ambient temperatures.

E. Isolation Relay (Heat Pump ONLY)

Mount isolation relay in unit control box and wire into power and control circuits. This relay switches MotorMaster® out of outdoor fan motor circuit when heat pump switches to heating cycle. Relay Part No. KHAIR0101AAA is REQUIRED for use with 208/230-v and 460-v systems. Note the following:

1. Normally closed relay contacts must be in parallel with MotorMaster® as shown in Fig. 8.
2. Normally open relay contacts must be in series with MotorMaster® as shown in Fig. 8.
3. Isolation relay coil must be connected across circuits O and C on defrost board.

F. Wiring

MotorMaster® must be wired in series with fan motor. (See Fig. 8.) Power wiring must comply with all local codes and NEC requirements.

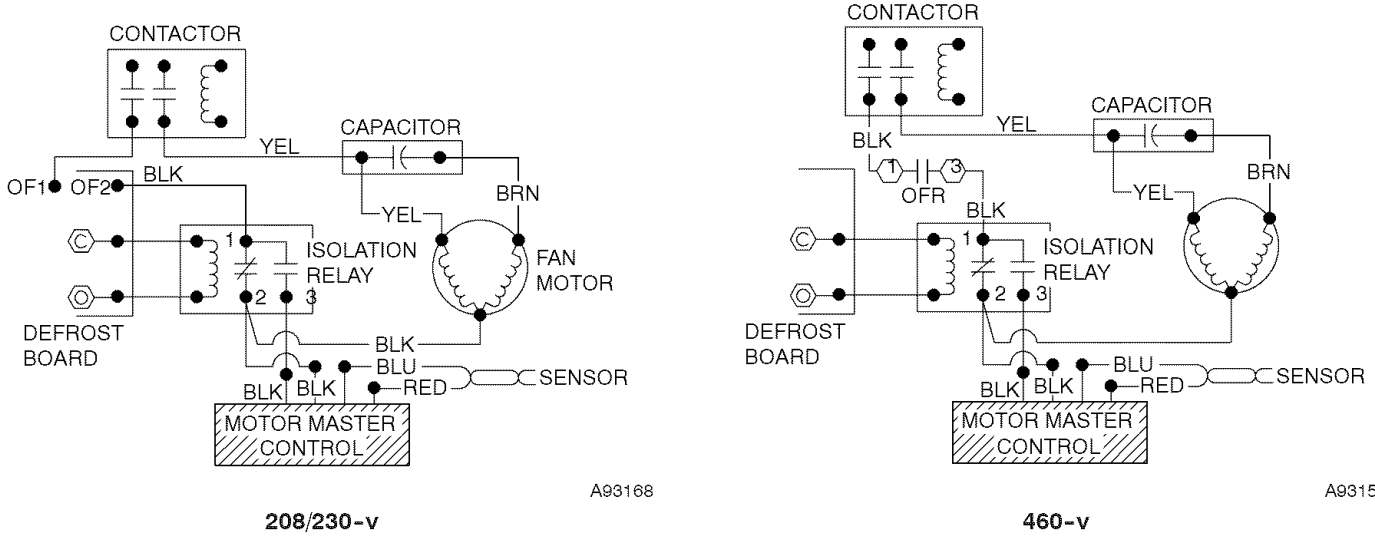

208/230-v

A93168

460-v

A93156

Fig. 8 - Power Wiring for 208/230-v and 460-v Heat Pump Units

START-UP

To start up units equipped with accessory MotorMaster®:

1. Turn unit power on.
2. Set thermostat below room temperature.
3. Wait at least 5 minutes if unit is equipped with a delay circuit. Fan motor starts 15 sec before compressor when standard delay circuits are used and may:
 - a. Not operate when ambient is below 50°F.
 - b. Run at slow speed when ambient is between 70°F and 80°F.
 - c. Run at or near full speed when ambient is above 80°F.
4. When compressor starts, fan speed modulates smoothly to proper controlled speed based on saturated condensing temperature. After system has run and settled out, saturation temperature is approximately 100°F ± 10°F, if the outdoor ambient is below 60°F.

SERVICE

No field repairs are to be made on this kit. If either the sensor or the control fails, it should be replaced.

If fan motor does not turn, check control as follows:

1. Check power to condensing unit.
2. Check for voltage across fan motor relay contacts.
3. Check for loose sensor wire connections in MotorMaster® splice compartment.
4. Bypass MotorMaster® by connecting black wire from unit contactor directly to black fan motor lead. (See Fig. 7 or 8 and unit wiring label.)
 - a. If fan does not turn, make sure motor is wired into circuit properly and run capacitor is not defective. Replace motor or capacitor if defective.
 - b. If fan motor runs, make sure that motor was wired in series with MotorMaster®.
5. If motor runs when connected to single-phase voltage supply, but does not run when connected in series with MotorMaster®, check sensor as follows:
 - a. Check temperature of return bend near sensor with an electronic thermometer.
 - b. Disconnect both sensor leads.
 - c. Check sensor resistance with an ohmmeter and compare resistance/temperature readings to those in Fig. 9.
 - d. If sensor is within tolerance shown in Fig. 9, replace MotorMaster®. If sensor is NOT within tolerance shown in Fig. 9, replace sensor.

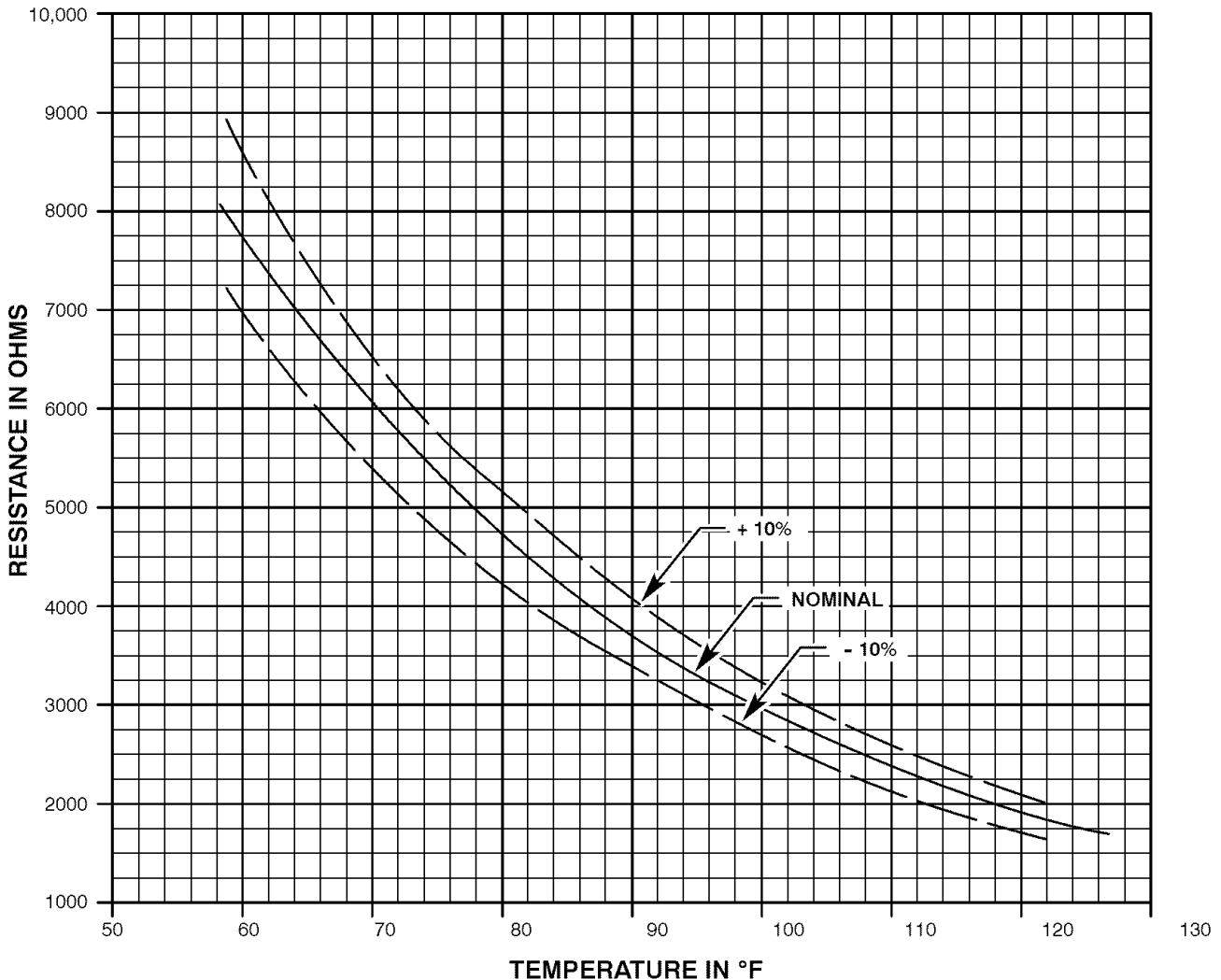

Fig. 9 - Sensor Resistance/Temperature Chart

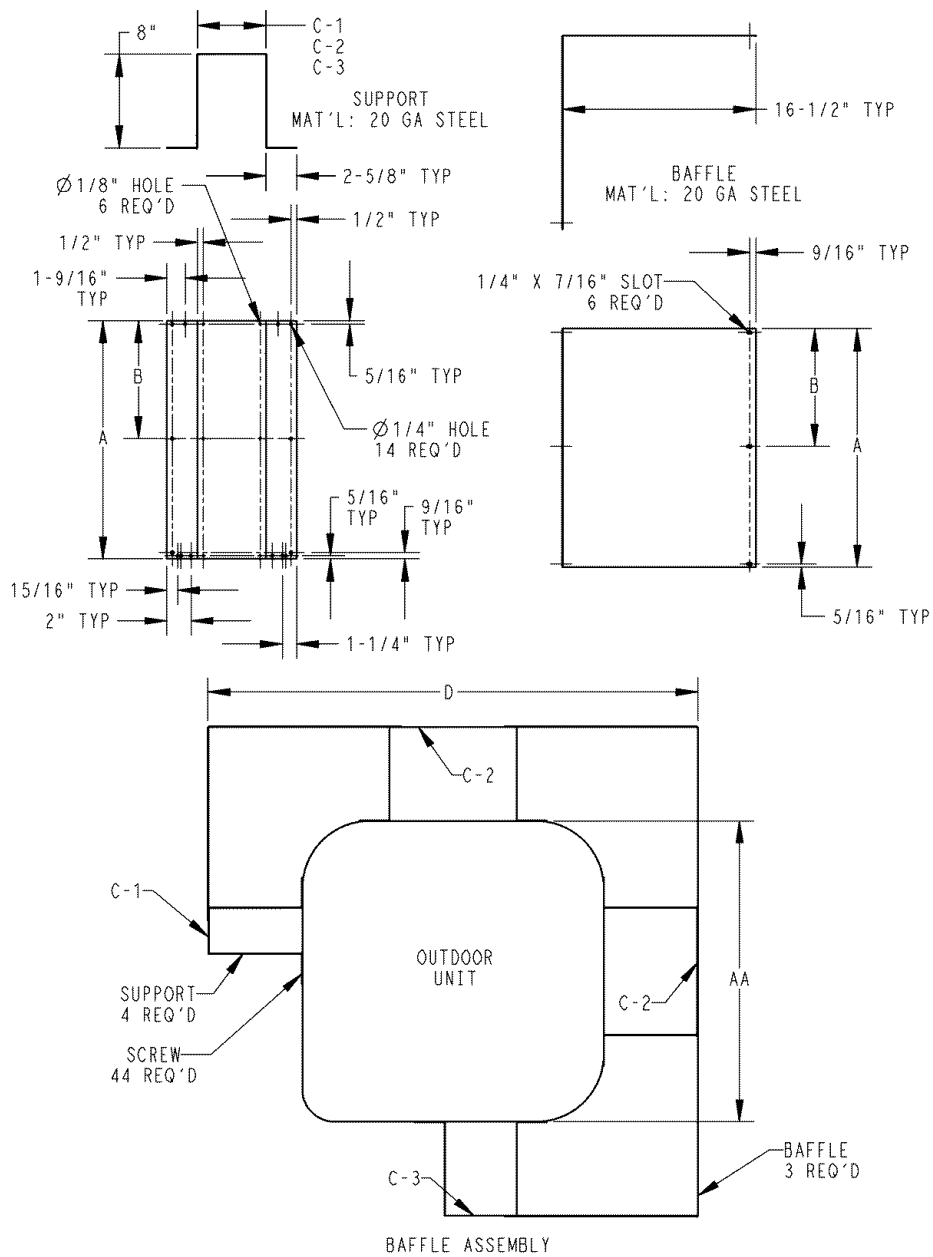

Fig. 10 - Base / Mid-Tier Baffle Assembly

A06450

Table 2—Wind Baffle Dimensions for Entry and Mid-Tier Units (in.)

UNIT SIZE	AA	UNIT HEIGHT	A	B	C-1	C-2	C-3	D
Small	25-3/4	25	20-3/8	10-1/16	3-15/16	10-7/8	6-1/8	41-7/8
		28-7/16	23-13/16	11-3/4				
		31-13/16	27-3/16	13-1/2				
		35-1/4	30-5/8	15-3/16				
		38-5/8	34	16-7/8				
		42	37-3/8	18-9/16				
Medium	31-1/4	45-7/16	40-13/16	20-1/4	9-3/8	16-5/16	11-9/16	47-3/8
		25-1/2	20-3/8	10-1/16				
		28-15/16	23-13/16	11-3/4				
		32-5/16	27-3/16	13-1/2				
		35-3/4	30-5/8	15-3/16				
		39-1/8	34	16-7/8				
Large	35	42-1/2	37-3/8	18-9/16	13-3/16	20-1/8	15-3/8	51-1/8
		45-15/16	40-13/16	20-1/4				
		25-1/2	20-3/8	10-1/16				
		28-15/16	23-13/16	11-3/4				
		32-5/16	27-3/16	13-1/2				
		35-3/4	30-5/8	15-3/16				

