



# Installation Instructions

**IMPORTANT:** This installation instruction contains basic unit installation information including installation of field control devices. For information on unit start-up, service, and operation, refer to the unit Controls, Start-Up, Operation, Service, and Troubleshooting Instructions also enclosed in the unit literature packet.

## TABLE OF CONTENTS

SAFETY CONSIDERATIONS ..... 1

GENERAL ..... 2

INSTALLATION ..... 2

    Step 1 - Provide Unit Support ..... 3

    Step 2 - Rig and Place Unit ..... 3

    Step 3 - Field Fabricate Ductwork ..... 8

    Step 4 - Make Unit Duct Connections ..... 8

    Step 5 - Install External Trap for Condensate Drain ..... 8

    Step 6 - Make Electrical Connections ..... 9

    Step 7 - Install Outdoor-Air Hoods (Units with Economizer) ..... 17

    Step 8 - Install All Accessories ..... 17


    Step 9 - Configure Controls ..... 17

## SAFETY CONSIDERATIONS


Installation and servicing of air-conditioning equipment can be hazardous due to system pressure and electrical components. Only trained and qualified service personnel should install, repair, or service air-conditioning equipment.

Untrained personnel can perform the basic maintenance functions of replacing filters. All other operations should be performed by trained service personnel. When working on air-conditioning equipment, observe precautions in the literature, tags and labels attached to the unit, and other safety precautions that may apply.

Follow all safety codes. Wear safety glasses and work gloves.

Recognize safety information. This is the safety-alert symbol . When you see this symbol on the furnace and in instructions or manuals, be alert to the potential for personal injury.


Understand the signal words DANGER, WARNING, and CAUTION. These words are used with the safety-alert symbol. DANGER identifies the most serious hazards which **will** result in severe personal injury or death. WARNING signifies a hazard which **could** result in personal injury or death. CAUTION is used to identify unsafe practices which **may** result in minor personal injury or product and property damage. NOTE is used to highlight suggestions which **will** result in enhanced installation, reliability, or operation.

 **WARNING**

**ELECTRICAL SHOCK HAZARD**

Failure to follow this warning could cause personal injury or death.

Before performing service or maintenance operations on unit, turn off main power switch to unit.

 **WARNING**

**UNIT OPERATION AND SAFETY HAZARD**

Failure to follow this warning could cause personal injury, death and/or equipment damage.

Puron® (R-410A) refrigerant systems operate at higher pressures than standard R-22 systems. Do not use R-22 service equipment or components on Puron refrigerant equipment.

**IMPORTANT:** Units have high ambient operating limits. If limits are exceeded, the units will automatically lock the compressor out of operation. Manual reset will be required to restart the compressor.

## GENERAL

The 50PD rooftop unit uses Puron® (R-410A) refrigerant and ComfortLink™ DDC controls. It is intended to be used in either a displacement ventilation or a single-zone variable air volume application. The unit includes a factory installed variable capacity compressor and variable frequency drive indoor fan motor. This manual provides instruction for installation of the unit. Refer to the unit Controls and Troubleshooting book for additional information on configuring controls.

## INSTALLATION

### Step 1 — Provide Unit Support

#### Roof Curb

Assemble or install accessory roof curb in accordance with instructions shipped with this accessory. (See Fig. 1.) Install insulation, cant strips, roofing, and counter flashing as shown. Ductwork can be installed to roof curb before unit is set in place. Ductwork must be attached to curb and not to the unit. Curb must be level. This is necessary to permit unit drain to function properly. Unit leveling tolerance is  $\pm 1/16$ -in. per linear ft in any direction. Refer to Accessory Roof Curb Installation Instructions for additional information as required. When accessory roof curb is used, unit may be installed on class A, B, or C roof covering material. Carrier roof curb accessories are for flat roofs or slab mounting.

**IMPORTANT:** The gasketing of the unit to the roof curb is critical for a watertight seal. Install gasket with the roof curb as shown in Fig. 1. Improperly applied gasket can also result in air leaks and poor unit performance. Do not slide unit to position on roof curb.

#### Alternate Unit Support

When a curb cannot be used, install unit on a noncombustible surface. Support unit with sleepers, using unit curb support area. If sleepers cannot be used, support long sides of unit with a minimum of 3 equally spaced 4-in. x 4-in. pads on each side.

### Step 2 — Rig and Place Unit

Inspect unit for transportation damage. See Table 1 for physical data. See Table 2 and 3 for fan and motor drive data. File any claim with transportation agency.

## CAUTION

### PERSONAL INJURY AND PROPERTY DAMAGE HAZARD

Failure to follow this caution may result in damage to roof.

All panels must be in place when rigging. Unit is not designed for handling by fork truck.

Do not drop unit; keep upright. Use spreader bars over unit to prevent sling or cable damage. Rollers may be used to move unit across a roof. Level by using unit rail as a reference. Leveling tolerance is  $\pm 1/16$ -in. per linear ft in any direction.

Refer to rigging instructions on unit. See Fig. 3 for additional information and unit rigging weight. Rigging holes are provided in the unit base rails as shown in Fig. 3.

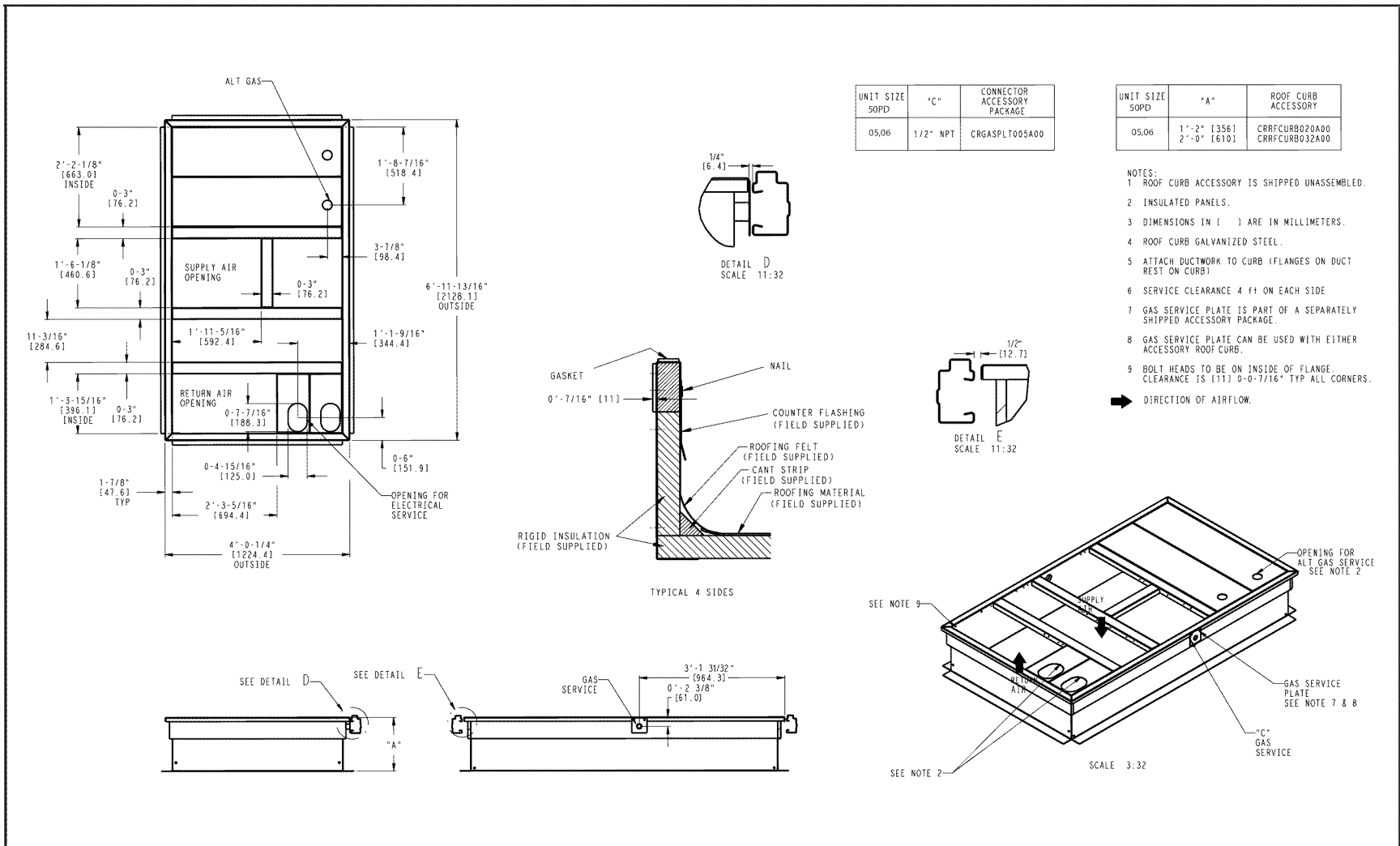
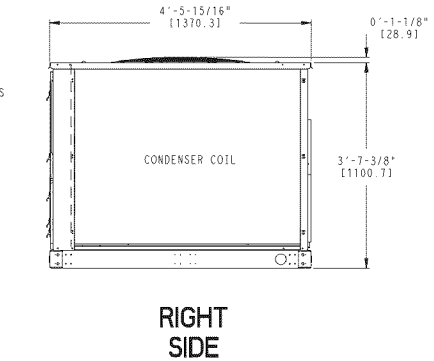
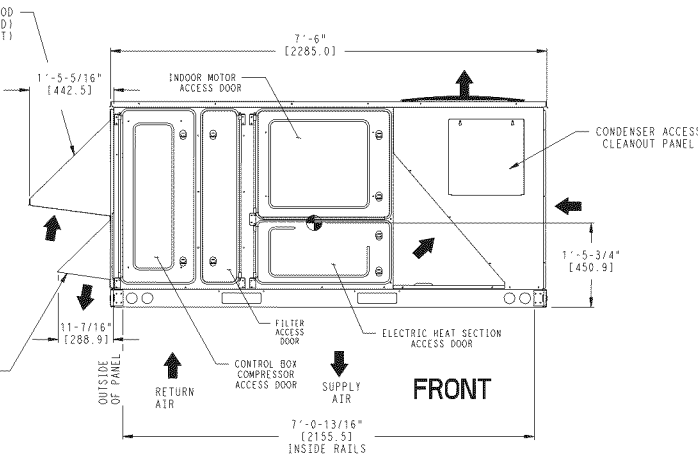
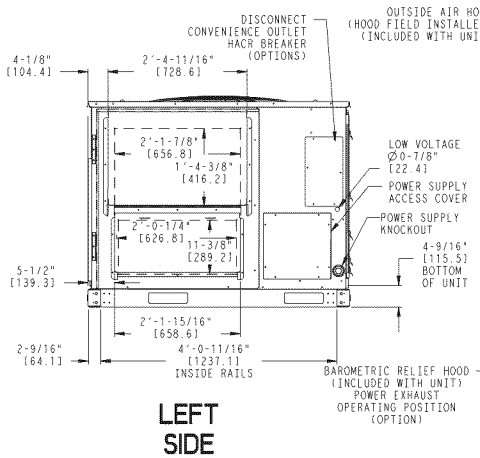
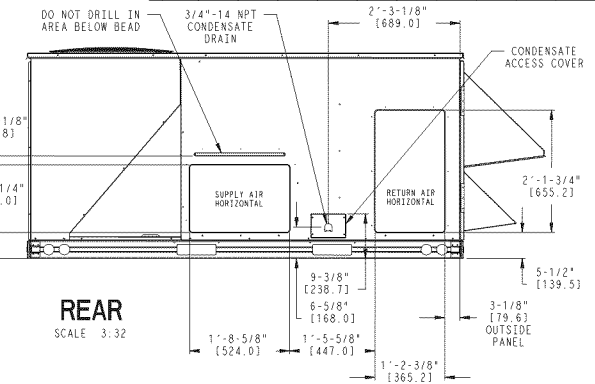
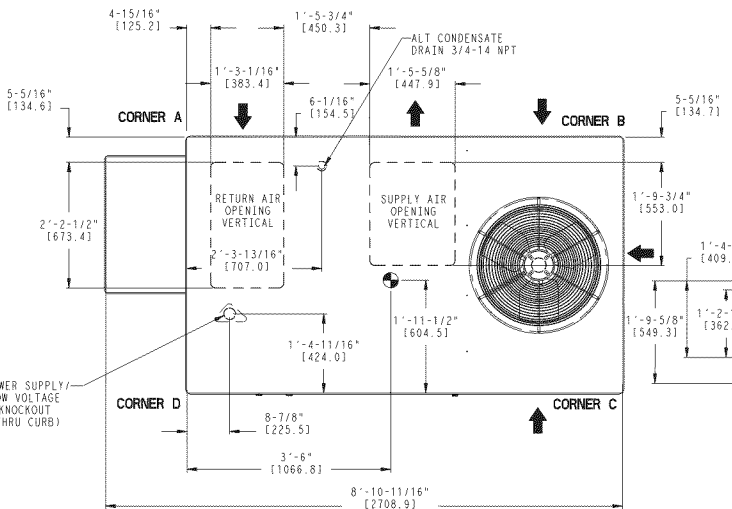


Fig. 1 - Roof Curb Details

NOTES:

1. DIMENSIONS IN ( ) ARE IN MILLIMETERS.
2. CENTER OF GRAVITY.
3. DIRECTION OF AIR FLOW.
4. ON VERTICAL DISCHARGE UNITS, DUCTWORK TO BE ATTACHED TO ACCESSORY ROOF CURB ONLY. FOR HORIZONTAL DISCHARGE UNITS FIELD SUPPLIED FLANGES SHOULD BE ATTACHED TO HORIZONTAL DISCHARGE OPENINGS, AND ALL DUCTWORK SHOULD BE ATTACHED TO THE FLANGES.
5. MINIMUM CLEARANCE (LOCAL CODES OR JURISDICTION MAY PREVAIL)
  - a. ON VERTICAL DISCHARGE UNITS, CLEARANCE TO COMBUSTIBLE FOR FIRST 12" OF DUCT TUBE 1"
  - b. BOTTOM OF UNIT TO COMBUSTIBLE SURFACES (WHEN NOT USING CURB) 1 INCH.
  - c. BOTTOM OF BASE RAIL TO COMBUSTIBLE SURFACES (WHEN NOT USING CURB) 0 INCHES
  - d. WHEN NOT USING ROOF CURB (0 INCHES) TO BOTTOM OF BASE RAIL RIGHT SIDE FRONT AND BACK SIDES (36 INCHES) FOR PROPER CONDENSER AIRFLOW.
  - e. OVERHEAD, 60 INCHES TO ASSURE PROPER CONDENSER FAN OPERATION.
  - f. BETWEEN UNITS, CONTROL BOX SIDE, 42 IN. PER NEC.
  - g. BETWEEN UNIT AND UNGROUNDED SURFACES, CONTROL BOX SIDE, 36 IN. PER NEC.
  - h. BETWEEN UNIT AND BLOCK OR CONCRETE WALLS AND OTHER GROUNDED SURFACES, CONTROL BOX SIDE, 42 IN. PER NEC.
  - i. HORIZONTAL SUPPLY AND RETURN END, 0 INCHES.
  - j. CLEARANCE IN FRONT OF INDOOR MOTOR ACCESS FOR BLOWER SLED REMOVAL 4'-6"
  - k. CLEARANCE FOR COMPLETE CONDENSATE PAN REMOVAL 4'-6"
6. WITH THE EXCEPTION OF THE CLEARANCE FOR THE CONDENSER COIL, A REMOVABLE FENCE OR BARRICADE REQUIRES NO CLEARANCE.
7. UNITS MAY BE INSTALLED ON COMBUSTIBLE FLOORS MADE FROM WOOD OR CLASS A, B, OR C ROOF COVERING MATERIAL IF SET ON BASE RAIL.

UNIT	STD. UNIT WEIGHT		CORNER WEIGHT (A)		CORNER WEIGHT (B)		CORNER WEIGHT (C)		CORNER WEIGHT (D)	
	LBS.	KG.	LBS.	KG.	LBS.	KG.	LBS.	KG.	LBS.	KG.
50PG03	704	319	162	73	142	64	187	85	214	97
50PG04	704	319	162	73	142	64	187	85	214	97
50PG05	775	352	178	81	156	71	206	93	235	107
50PG06	829	376	191	86	167	76	220	100	252	114
50PG07	874	396	201	91	176	80	232	105	265	120
50PD05	775	352	178	81	156	71	206	93	235	107
50PD06	829	376	191	86	167	76	220	100	252	114



4

Fig. 2 - Base Unit Dimensions

**⚠ CAUTION - NOTICE TO RIGGERS:  
ACCESS PANEL MUST BE IN PLACE WHEN RIGGING.**

Hook rigging shackles through holes in base rail, as shown in Detail A. Holes in base rails are centered around the unit center of gravity. Use wooden top skid, when rigging, to prevent rigging straps from damaging unit.

UNIT SIZE	A		B		C		D		E		MAX. WEIGHT	
	in.	mm	in.	mm	in.	mm	in.	mm	in.	mm	lb	kg
05-06	77.9	1978	36-54	914-1371	44.8	1139	42.0	1067	23.5	597	1156	525

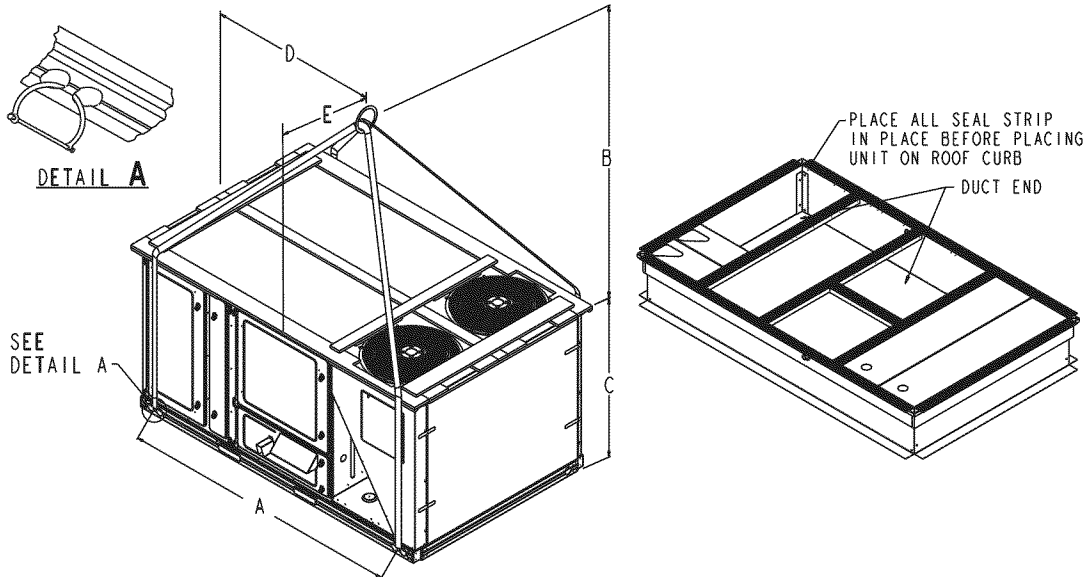


Fig. 3 - Rigging Label

C08433

**Positioning**

Maintain clearance, per Fig. 2, around and above unit to provide minimum distance from combustible materials, proper airflow, and service access.

Do not install unit in an indoor location. Do not locate air inlets near exhaust vents or other sources of contaminated air. For proper unit operation, adequate combustion and ventilation air must be provided in accordance with Section 5.3 (Air for Combustion and Ventilation) of the National Fuel Gas Code, ANSI Z223.1 (American National Standards Institute).

Although unit is weatherproof, guard against water from higher level runoff and overhangs.

**Roof Mount**

Check building codes for weight distribution requirements. Unit operating weight is shown in Table 1.

**Installation On Roof Curb**

The 50PD units are designed to fit on the accessory full perimeter curb. Correct placement of the unit onto the curb is critical to proper operating performance. To aid in correct positioning, place unit on roof curb to maintain 1/4-in. gap between the inside of rail and roof curb on long sides and a 1/2-in. gap between the inside of rail and roof curb on both duct and condenser ends. Refer to Fig. 1 and 2 to assure proper duct opening alignment.

**NOTE:** Before positioning unit onto curb, refer to Step 5 - Install External Trap for Condensate Drain concerning bottom drain connection plug.

**⚠ CAUTION**

**EQUIPMENT DAMAGE HAZARD**

Failure to follow this caution may result in unit damage.

Do not slide unit into position when it is sitting on the curb. Curb gasketing material may be damaged and leaks may result.

**Slab Mount (Horizontal Units Only)**

Provide a level concrete slab that extends a minimum of 6-in. beyond unit cabinet. Install a gravel apron in front of condenser-coil air inlet to prevent grass and foliage from obstructing airflow.

**NOTE:** Horizontal units may be installed on a roof curb if required.

50PD

**Table 1 – Physical Data**

UNIT 50PD	05	06
<b>NOMINAL CAPACITY (TONS)</b>	4	5
<b>OPERATING WEIGHT (lbs)</b>		
Base Unit	901	921
Economizer Vertical / Horizontal	40 / 50	40 / 50
Roof Curb 14–in / 24–in	122 / 184	122 / 184
<b>REFRIGERANT SYSTEM</b>		
Refrigerant	Puron® (410a)	
Metering Device	Balanced–Port TXV with Bypass	
# Circuits / # Compressors	1 / 1	1 / 1
Charge (lbs)	14.5	16.0
High Pressure Switch Cutout (psig)	660 +/- 10	660 +/- 10
High Pressure Switch Auto Reset (psig)	505 +/- 20	505 +/- 20
<b>COMPRESSOR</b>		
Oil Type	Copeland Digital Scroll Copeland 3MA	
Oil (oz)	42	42
<b>CONDENSER COIL</b>		
	Round Tube Plate Fin	
Circuit	Outer / Inner	Outer / Inner
Rows / FPI	2 / 17	2 / 17
Face Area (sq ft)	12.6	12.6
<b>CONDENSER FAN (type)</b>		
	Propeller	
Quantity / Diameter (in.)	1 / 24	1 / 24
Nominal CFM (Total, all fans)	3500	3500
Motor Nominal Hp / Watts	0.125 / 227	0.25 / 351
Nominal RPM	825	1100
<b>EVAPORATOR COIL</b>		
	Round Tube Plate Fin	
Standard coil Tube / Fins	Cu/Al	Cu/Al
Rows / FPI	2 / 15	3 / 15
Face Area (sq ft)	9.3	9.3
Condensate drain conn. Size (in.)	3/4 NPT	3/4 NPT
<b>EVAPORATOR FAN (see motor &amp; drive tables)</b>		
Fan Quantity / Type	1 / Belt	1 / Belt
Belt Size (in.)	12 x 9	12 x 9
Blower Pulley Type	Fixed	Fixed
Fan type	Centrifugal	Centrifugal
Fan Bearing Type	Ball – Concentric Lock	Ball – Concentric Lock
Maximum Fan RPM	2000	2000
Blower Shaft Diameter (in.)	0.75	0.75
Motor Max HP	2.4	2.4
Motor Frame Size	56HZ	56HZ
<b>FILTERS</b>		
Unit Filter Type	Fiberglass fill, non–pleated	Fiberglass fill, non–pleated
Unit Filter Qty / size (in)	4 / 16 x 20 x 2	4 / 16 x 20 x 2
Economizer OA inlet screen Qty / size (in)	1 / 25.8 x 16.4	1 / 25.8 x 16.4

50PD

**Table 2 – Fan Motor and Drive Data - Vertical Supply/Return**

<b>UNIT 50PD</b>	<b>05</b>	<b>06</b>
Voltage (volts)	208/230 and 460	208/230 and 460
<b>LOW STATIC DRIVE OPTION</b>		
Motor HP	2.4	2.4
Motor Nominal RPM	1725	1725
Maximum Continuous BHP	2.0	2.0
Maximum Continuous Watts	2000	2000
Motor Frame Size	56HZ	56HZ
Motor shaft diameter (in.)	5/8	5/8
Motor Pulley Pitch Diameter Min – Max (in)	1.9 – 2.9	2.4 – 3.4
Fan RPM Range	596–910	690–978
Blower Pulley Pitch Diameter (in.)	5.5	6.0
Pulley center line distance (in.)	16.2–20.2	16.2–20.2
Belt Quantity / Type / Pitch Length (in.)	1 / AX48 / 49.3	1 / AX48 / 49.3
Speed change per turn – moveable pulley (RPM)	63	58
Moveable pulley maximum full turns	5	5
Factory Speed setting (RPM)	596	690
<b>HIGH STATIC DRIVE OPTION</b>		
Motor HP	2.4	2.4
Motor Nominal RPM	1725	1725
Maximum Continuous BHP	2.0	2.0
Maximum Continuous Watts	2000	2000
Motor Frame Size	56HZ	56HZ
Motor shaft diameter (in.)	5/8	5/8
Motor Pulley Pitch Diameter Min – Max (in)	2.4 – 3.4	2.8 – 3.8
Fan RPM Range	828–1173	929–1261
Blower Pulley Pitch Diameter (in.)	5.0	5.2
Pulley center line distance (in.)	16.2–20.2	16.2–20.2
Belt Quantity / Type / Pitch Length (in.)	1 / AX48 / 49.3	1 / AX48 / 49.3
Speed change per turn – moveable pulley (RPM)	69	67
Moveable pulley maximum full turns	5	5
Factory Speed setting (RPM)	828	929

**50PD**

**Table 3 – Fan Motor and Drive Data - Horizontal Supply/Return**

<b>UNIT 50PD</b>	<b>05</b>	<b>06</b>
Voltage (volts)	208/230 and 460	208/230 and 460
<b>LOW STATIC DRIVE OPTION</b>		
Motor HP	2.4	2.4
Motor Nominal RPM	1725	1725
Maximum Continuous BHP	2.0	2.0
Maximum Continuous Watts	2000	2000
Motor Frame Size	56HZ	56HZ
Motor shaft diameter (in.)	5/8	5/8
Motor Pulley Pitch Diameter Min – Max (in)	1.9 – 2.9	2.4 – 3.4
Fan RPM Range	596–910	690–978
Blower Pulley Pitch Diameter (in.)	5.5	6.0
Pulley center line distance (in.)	16.2–20.2	16.2–20.2
Belt Quantity / Type / Pitch Length (in.)	1 / AX48 / 49.3	1 / AX48 / 49.3
Speed change per turn – moveable pulley (RPM)	63	58
Moveable pulley maximum full turns	5	5
Factory Speed setting (RPM)	596	690
<b>HIGH STATIC DRIVE OPTION</b>		
Motor HP	2.4	2.4
Motor Nominal RPM	1725	1725
Maximum Continuous BHP	2.0	2.0
Maximum Continuous Watts	2000	2000
Motor Frame Size	56HZ	56HZ
Motor shaft diameter (in.)	5/8	5/8
Motor Pulley Pitch Diameter Min – Max (in)	2.4 – 3.4	2.8 – 3.8
Fan RPM Range	828–1173	929–1261
Blower Pulley Pitch Diameter (in.)	5.0	5.2
Pulley center line distance (in.)	16.2–20.2	16.2–20.2
Belt Quantity / Type / Pitch Length (in.)	1 / AX48 / 49.3	1 / AX48 / 49.3
Speed change per turn – moveable pulley (RPM)	69	67
Moveable pulley maximum full turns	5	5
Factory Speed setting (RPM)	828	929

### Step 3 — Field Fabricate Ductwork

On vertical units, secure all ducts to roof curb and building structure. Do not connect ductwork to unit. For horizontal applications, field-supplied flanges should be attached to horizontal discharge openings and all ductwork secured to the flanges. Insulate and weatherproof all external ductwork, joints, and roof openings with counter flashing and mastic in accordance with applicable codes.

Ducts passing through an unconditioned space must be insulated and covered with a vapor barrier.

If a plenum return is used on a vertical unit, the return should be ducted through the roof deck to comply with applicable fire codes.

A minimum clearance is not required around ductwork. Cabinet return-air static pressure (a negative condition) shall not exceed 0.35-in.wg with economizer or 0.45-in.wg without economizer.

These units are designed for a minimum continuous return air temperature in heating of 50°F (dry bulb), or an intermittent operation down to 45°F (dry bulb), such as when used with a night set-back thermostat.

To operate at lower return-air temperatures, a field-supplied outdoor-air temperature control must be used to initiate both stages of heat when the temperature is below 45°F. Indoor comfort may be compromised when these lower air temperatures are used with insufficient heating temperature rise.

### Step 4 — Make Unit Duct Connections

#### Vertical Supply/Return Configuration

Unit is shipped in vertical supply/return configuration. Ductwork openings are shown in Fig. 1 and 2. Attach the ductwork to the roof curb. Do not attach duct directly to the unit.

**⚠ WARNING**

**UNIT DAMAGE AND PERSONAL INJURY HAZARD**

Failure to follow this warning could cause equipment damage and/or personal injury.

For vertical supply and return units, tools or parts could drop into ductwork and cause an injury. Install a 90-degree turn in the return ductwork between the unit and the conditioned space. If a 90-degree elbow cannot be installed, then a grille of sufficient strength and density should be installed to prevent objects from falling into the conditioned space.

#### Horizontal Supply/Return Applications

Unit can be field-converted from vertical supply/return to horizontal supply/return. Remove all screws securing horizontal duct covers to duct panel. Save panels. Install duct covers in the vertical duct openings in the basepan with the insulation side up.

Covers will drop into openings and can be secured using field-supplied self-tapping screws. Ductwork can be attached to duct flanges provided on unit. When securing ductwork to unit, do not drill in area below bead or above top edge of duct opening.

### Step 5 — Install External Trap for Condensate Drain

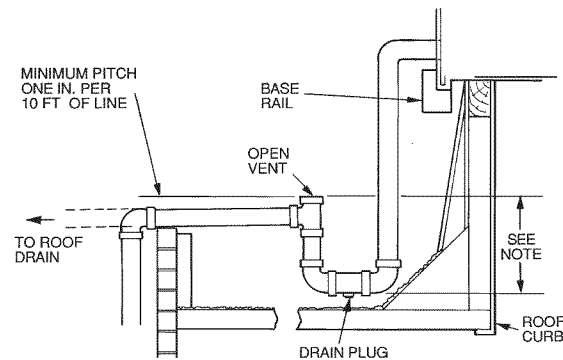
The unit's 3/4-in. condensate drain connections are located on the bottom and side of the unit. Unit discharge connections do not determine the use of drain connections; either drain connection can be used with vertical or horizontal applications. See Fig. 2 for locations.

When using the standard side drain connection, make sure the plug (red) in the alternate bottom connection is tight before installing the unit. (See Fig. 5.)

To use the bottom drain connection for a roof curb installation, relocate the factory-installed plug (red) from the bottom connection to the side connection. A 1/2-in. socket extension can be used to remove the plug. (See Fig. 5.) The piping for the condensate drain and external trap can be completed after the unit is in place.

All units must have an external trap for condensate drainage. Install a trap at least 4-in. deep and protect against freezeup. If drain line is installed downstream from the external trap, pitch the line away from the unit at 1-in. per 10 ft of run. Do not use a pipe size smaller than the unit connection (3/4-in.). (See Fig. 4 and 6.)

The 50PD units are provided with a removable condensate pan for ease of cleaning. Refer to Maintenance section in Controls and Troubleshooting book for more information. It is recommended that a union be placed between the unit and condensate drainage to ease the removal of the pan during servicing. Adequate clearance should be allowed if removal of condensate pan is required. Allow 54-in. between condensate pan access panel and any obstruction for complete removal.

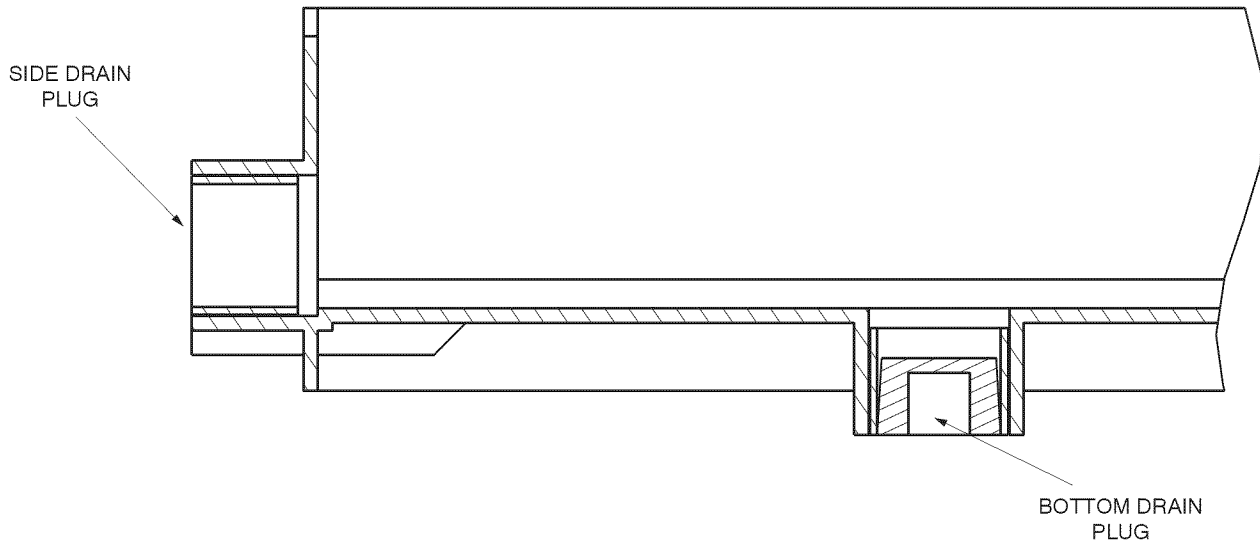


NOTE: Trap should be deep enough to offset maximum unit static difference. A 4-in. trap is recommended.

Fig. 4 - Condensate Drain Piping Details

C06291

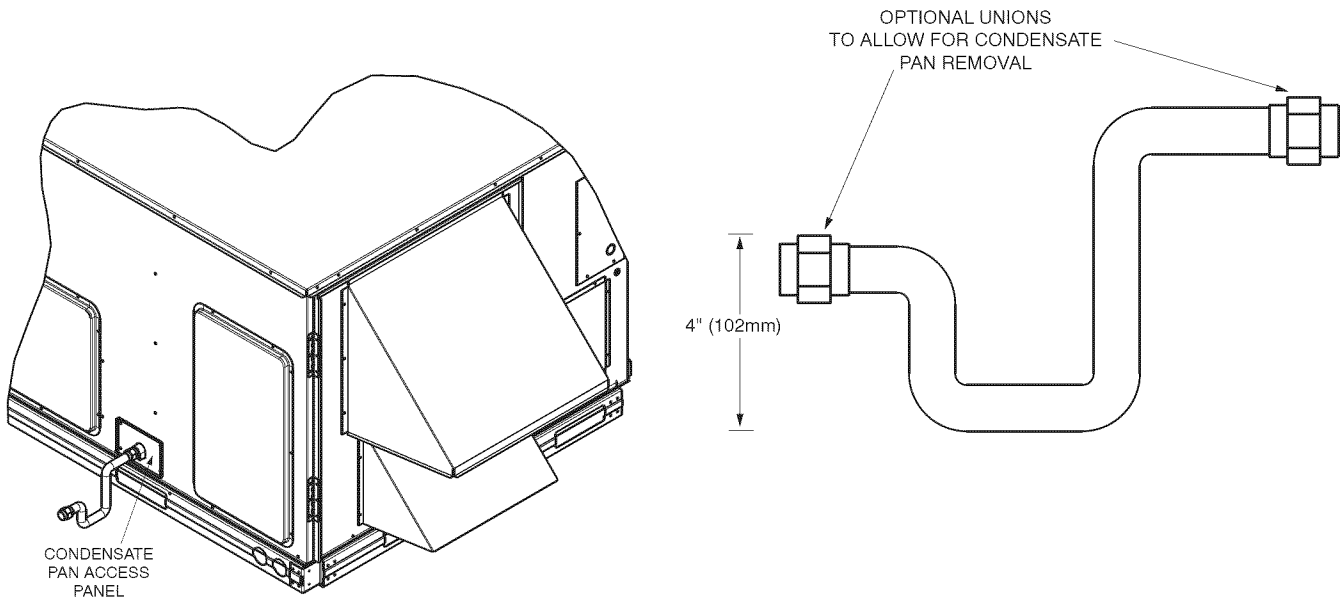




**Fig. 5 - Condensate Drain Piping Details**

C06233

50PD



**Fig. 6 - External Trap for Condensate Drain**

C06234

## Step 6 — Make Electrical Connections

### Field Power Supply

(For more details, refer to the Controls, Start-Up, Operation, and Troubleshooting manual).

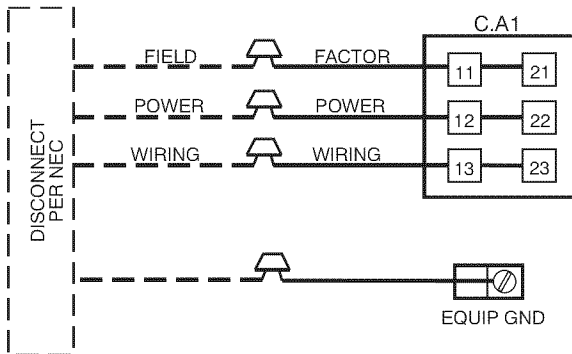
All 208/230v units are factory wired for 230v power supply. If the 208/230v unit is to be connected to a 208v power supply, the transformers (TRAN1 and TRAN2) must be rewired by moving the black wire with the 1/4-in. female quick connector from the 230volt connection and moving to the 200volt 1/4-in. male terminal on the primary side of the transformer.

Refer to unit label diagram for additional information. Leads are provided for field wire connections. Use UL (Underwriters Laboratories) approved copper/aluminum connector.

When installing units, provide safety disconnect per NEC (National Electrical Code) Article 440 or local codes. For non-fused disconnects, size disconnect according to the sizing data provided in the electrical data tables. If a fused disconnect is used, determine the minimum size for the switch based on the disconnect sizing data provided in the electrical data tables and then coordinate the disconnect housing size to accommodate the Maximum OverCurrent Protection (MOCP) device size as marked on the unit informative plate. (See Table 4 and 5.)

All field wiring must comply with NEC and local codes. Main wire size must be based on MCA (Minimum Circuit Amps) on the unit informative plate. See Fig. 7 for power wiring connection to the unit leads and equipment ground.

Route power and ground lines through control box end panel or unit basepan (see Fig. 2) to connections as shown on unit wiring diagram and Fig. 7. Factory leads may be wired directly to the unit disconnect.



**LEGEND**

- C.A1** -- Compressor Contactor (A1)
- EQUIP** -- Equipment
- GND** -- Ground
- NEC** -- National Electrical Code

NOTE: The maximum wire size for C.A1 is 2/0.

C06237

**Fig. 7 - Field Power Wiring Connections**

## ⚠ CAUTION

**UNIT DAMAGE HAZARD**

Failure to follow this caution may result in damage to unit. The correct power phasing is critical to the operation of the scroll compressors. An incorrect phasing will result in an alarm being generated and compressor operation lockout. Should this occur, power phase correction must be made to the incoming power.

## ⚠ WARNING

**ELECTRICAL SHOCK AND FIRE HAZARD**

Failure to follow this warning could result in electrical shock, fire, or death.

Unit cabinet must have an uninterrupted, unbroken electrical ground to minimize the possibility of personal injury if an electrical fault should occur. This ground may consist of electrical wire connected to unit ground lug in control compartment or conduit approved for electrical ground when installed in accordance with NEC; ANSI (American National Standards Institute)/NFPA (National Fire Protection Association), latest edition, and local electrical codes. Do not use gas piping as an electrical ground.

Field wiring must conform to temperature limitations for type “T” wire. All field wiring must comply with NEC and local requirements.

Operating voltage to compressor must be within voltage range indicated on unit nameplate. On 3-phase units, voltages between phases must be balanced within 2%.

Unit failure as a result of operation on improper line voltage or excessive phase imbalance constitutes abuse and may cause damage to electrical components.

**Field Control Wiring**

Unit can be controlled using a Carrier-approved space temperature sensor. Install sensor according to the installation instructions included with accessory. Locate space temperature sensor on a solid interior wall in the conditioned space to sense average temperature.

Route space temperature sensor cable or equivalent single leads of colored wire through conduit into unit to low-voltage connections as shown on unit label wiring diagram and in Fig. 8.

**NOTE:** For wire runs up to 50 ft, use no. 18 AWG (American Wire Gauge) insulated wire (35°C minimum). For 50 to 75 ft, use no. 16 AWG insulated wire (35°C minimum). For over 75 ft, use no. 14 AWG insulated wire (35°C minimum). All wire larger than no. 18 AWG cannot be directly connected at the sensor and will require a junction box and splice.

50PD

## Humidity Control

The 50PD unit can be used with a Carrier accessory humidistat switch output (HL38MG029 or TSTATCCPLH01-B) in conjunction with the space temperature sensor. The humidistat switch is a normally open switch that closes upon a rise in space humidity, above the setpoint value.

Upon a humidistat call the supply air temperature is lowered to produce a colder evaporator coil and lower dew point temperature. When humidistat is satisfied the supply air temperature is reset to the original supply air temperature setpoint.

Install the humidity control device according to the installation instructions included with the accessory. Locate the device on a solid interior wall in the conditioned space to sense average humidity. General humidistat and humidity sensor wiring connections are shown in Fig. 8.

Configuration of the unit control is required to specify the control input type before unit operation. Refer to the Controls, Start-Up, Operation and Troubleshooting manual for configuration.

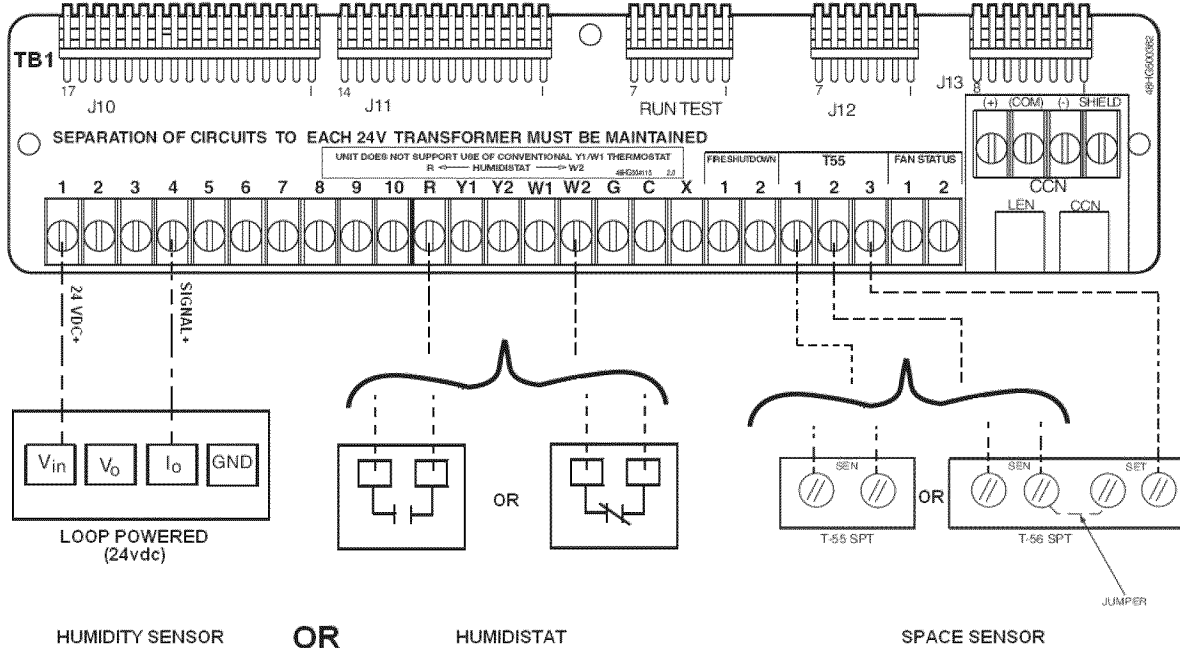


Fig. 8 - Low Voltage Terminal Strip Wiring

C08434

Table 4 – Electrical Data - Units Without Optional Convenience Outlet

50PD UNIT SIZE	NOMINAL POWER SUPPLY V-Ph-Hz	VOLTAGE RANGE		COMPRESSOR		OFM		CONV OUTLET	PWR EXH (FLA)	IFM		ELECTRIC HEAT			POWER SUPPLY		SINGLE POINT KIT	DISCONNECT SIZE	
		Min	Max	RLA	LRA	Qty	FLA			TYPE	FLA	Heater Number	FLA	Nom. kW	MCA	MOCP†		FLA	LRA
05	208/230-3-60	187	253	16.1	110	1	1.0	none	-	STD	5.2	-	-	-	26.3/26.3	40/40	-	26/26	142/142
												CRHEATER208A00	10.0/11.5	3.8/5.0	26.3/26.3	40/40	-	26/26	142/142
												CRHEATER209A00	15.0/17.3	5.6/7.5	26.3/28.1	40/40	-	26/26	142/142
												CRHEATER210A00	20.0/23.1	7.5/10.0	31.5/35.4	40/40	-	29/33	142/142
												CRHEATER211A00	30.0/34.6	11.3/15.0	44.0/49.8	45/50	-	40/46	142/142
												CRHEATER212A00	40.0/46.2	15.0/20.0	56.5/64.3	60/70	031	52/59	142/142
											-	-	-	26.3/26.3	40/40	-	26/26	142/142	
											CRHEATER208A00	10.0/11.5	3.8/5.0	26.3/26.3	40/40	-	26/26	142/142	
											CRHEATER209A00	15.0/17.3	5.6/7.5	26.3/28.1	40/40	-	26/26	142/142	
											CRHEATER210A00	20.0/23.1	7.5/10.0	31.5/35.4	40/40	-	29/33	142/142	
											CRHEATER211A00	30.0/34.6	11.3/15.0	44.0/49.8	45/50	-	40/46	142/142	
											CRHEATER212A00	40.0/46.2	15.0/20.0	56.5/64.3	60/70	031	52/59	142/142	
										-	-	-	27.7/27.7	40/40	-	27/27	144/144		
										CRHEATER208A00	10.0/11.5	3.8/5.0	27.7/27.7	40/40	-	27/27	144/144		
										CRHEATER209A00	15.0/17.3	5.6/7.5	27.7/29.9	40/40	-	27/27	144/144		
										CRHEATER210A00	20.0/23.1	7.5/10.0	33.3/37.1	40/40	-	31/34	144/144		
										CRHEATER211A00	30.0/34.6	11.3/15.0	45.8/51.5	50/60	-	42/47	144/144		
										CRHEATER212A00	40.0/46.2	15.0/20.0	58.3/66.0	60/70	031	54/61	144/144		
										-	-	-	27.7/27.7	40/40	-	27/27	144/144		
										CRHEATER208A00	10.0/11.5	3.8/5.0	27.7/27.7	40/40	-	27/27	144/144		
										CRHEATER209A00	15.0/17.3	5.6/7.5	27.7/29.9	40/40	-	27/27	144/144		
										CRHEATER210A00	20.0/23.1	7.5/10.0	33.3/37.1	40/40	-	31/34	144/144		
										CRHEATER211A00	30.0/34.6	11.3/15.0	45.8/51.5	50/60	-	42/47	144/144		
										CRHEATER212A00	40.0/46.2	15.0/20.0	58.3/66.0	60/70	031	54/61	144/144		
	-	-	-	10.9	15	-	11	68											
	CRHEATER215A00	5.8	5.0	10.9	15	-	11	68											
	CRHEATER216A00	8.7	7.5	14.1	15	-	13	68											
	CRHEATER217A00	11.5	10.0	17.6	20	-	16	68											
	CRHEATER218A00	17.3	15.0	24.9	25	-	23	68											
	CRHEATER219A00	23.1	20.0	32.1	35	-	30	68											
	-	-	-	10.9	15	-	11	68											
	CRHEATER215A00	5.8	5.0	10.9	15	-	11	68											
	CRHEATER216A00	8.7	7.5	14.1	15	-	13	68											
	CRHEATER217A00	11.5	10.0	17.6	20	-	16	68											
	CRHEATER218A00	17.3	15.0	24.9	25	-	23	68											
	CRHEATER219A00	23.1	20.0	32.1	35	-	30	68											
	-	-	-	11.5	15	-	11	69											
	CRHEATER215A00	5.8	5.0	11.5	15	-	11	69											
	CRHEATER216A00	8.7	7.5	14.9	15	-	14	69											
	CRHEATER217A00	11.5	10.0	18.4	20	-	17	69											
	CRHEATER218A00	17.3	15.0	25.6	30	-	24	69											
	CRHEATER219A00	23.1	20.0	32.9	35	-	30	69											
	-	-	-	11.5	15	-	11	69											
	CRHEATER215A00	5.8	5.0	11.5	15	-	11	69											
	CRHEATER216A00	8.7	7.5	14.9	15	-	14	69											
	CRHEATER217A00	11.5	10.0	18.4	20	-	17	69											
	CRHEATER218A00	17.3	15.0	25.6	30	-	24	69											
	CRHEATER219A00	23.1	20.0	32.9	35	-	30	69											

Table 4 - Electrical Data - Units Without Optional Convenience Outlet (cont)

50PD UNIT SIZE	NOMINAL POWER SUPPLY V-Ph-Hz	VOLTAGE RANGE		COMPRESSOR		OFM		CONV OUTLET	PWR EXH (FLA)	IFM		ELECTRIC HEAT			POWER SUPPLY		SINGLE POINT KIT	DISCONNECT SIZE	
		Min	Max	RLA	LRA	Qty	FLA			TYPE	FLA	Heater Number	FLA	Nom. kW	MCA	MOCP†		FLA	LRA
06	208/230-3-60	187	253	17.9	110	1	1.5	none	-	STD	5.2	-	-	-	29.1/29.1	45/45	-	28/28	143/143
												CRHEATER208A00	10.0/11.5	3.8/5.0	29.1/29.1	45/45	-	28/28	143/143
												CRHEATER209A00	15.0/17.3	5.6/7.5	29.1/29.1	45/45	-	28/28	143/143
												CRHEATER210A00	20.0/23.1	7.5/10.0	31.5/35.4	45/45	-	29/33	143/143
												CRHEATER211A00	30.0/34.6	11.3/15.0	44.0/49.8	45/50	-	40/46	143/143
												CRHEATER212A00	40.0/46.2	15.0/20.0	56.5/64.3	60/70	031	52/59	143/143
												CRHEATER213A00	50.0/57.7	18.8/25.0	69.0/78.6	70/80	031	63/72	143/143
												-	-	-	29.1/29.1	45/45	-	28/28	143/143
												CRHEATER208A00	10.0/11.5	3.8/5.0	29.1/29.1	45/45	-	28/28	143/143
												CRHEATER209A00	15.0/17.3	5.6/7.5	29.1/29.1	45/45	-	28/28	143/143
												CRHEATER210A00	20.0/23.1	7.5/10.0	31.5/35.4	45/45	-	29/33	143/143
												CRHEATER211A00	30.0/34.6	11.3/15.0	44.0/49.8	45/50	-	40/46	143/143
										CRHEATER212A00	40.0/46.2	15.0/20.0	56.5/64.3	60/70	031	52/59	143/143		
										CRHEATER213A00	50.0/57.7	18.8/25.0	69.0/78.6	70/80	031	63/72	143/143		
										-	-	-	30.5/30.5	45/45	-	30/30	145/145		
										CRHEATER208A00	10.0/11.5	3.8/5.0	30.5/30.5	45/45	-	30/30	145/145		
										CRHEATER209A00	15.0/17.3	5.6/7.5	30.5/30.5	45/45	-	30/30	145/145		
										CRHEATER210A00	20.0/23.1	7.5/10.0	33.3/37.1	45/45	-	31/34	145/145		
										CRHEATER211A00	30.0/34.6	11.3/15.0	45.8/51.5	50/60	-	42/47	145/145		
										CRHEATER212A00	40.0/46.2	15.0/20.0	58.3/66.0	60/70	031	54/61	145/145		
										CRHEATER213A00	50.0/57.7	18.8/25.0	70.8/80.4	80/90	031	65/74	145/145		
										-	-	-	30.5/30.5	45/45	-	30/30	145/145		
										CRHEATER208A00	10.0/11.5	3.8/5.0	30.5/30.5	45/45	-	30/30	145/145		
										CRHEATER209A00	15.0/17.3	5.6/7.5	30.5/30.5	45/45	-	30/30	145/145		
	CRHEATER210A00	20.0/23.1	7.5/10.0	33.3/37.1	45/45	-	31/34	145/145											
	CRHEATER211A00	30.0/34.6	11.3/15.0	45.8/51.5	50/60	-	42/47	145/145											
	CRHEATER212A00	40.0/46.2	15.0/20.0	58.3/66.0	60/70	031	54/61	145/145											
	CRHEATER213A00	50.0/57.7	18.8/25.0	70.8/80.4	80/90	031	65/74	145/145											
	-	-	-	13.2	20	-	13	69											
	CRHEATER215A00	5.8	5.0	13.2	20	-	13	69											
	CRHEATER216A00	8.7	7.5	14.1	20	-	13	69											
	CRHEATER217A00	11.5	10.0	17.6	20	-	16	69											
	CRHEATER218A00	17.3	15.0	24.9	25	-	23	69											
	CRHEATER219A00	23.1	20.0	32.1	35	-	30	69											
	CRHEATER220A00	28.9	25.0	39.4	40	-	36	69											
	-	-	-	13.2	20	-	13	69											
	CRHEATER215A00	5.8	5.0	13.2	20	-	13	69											
	CRHEATER216A00	8.7	7.5	14.1	20	-	13	69											
	CRHEATER217A00	11.5	10.0	17.6	20	-	16	69											
	CRHEATER218A00	17.3	15.0	24.9	25	-	23	69											
	CRHEATER219A00	23.1	20.0	32.1	35	-	30	69											
	CRHEATER220A00	28.9	25.0	39.4	40	-	36	69											
	-	-	-	13.8	20	-	14	70											
	CRHEATER215A00	5.8	5.0	13.8	20	-	14	70											
	CRHEATER216A00	8.7	7.5	14.9	20	-	14	70											
	CRHEATER217A00	11.5	10.0	18.4	20	-	17	70											
	CRHEATER218A00	17.3	15.0	25.6	30	-	24	70											
	CRHEATER219A00	23.1	20.0	32.9	35	-	30	70											
CRHEATER220A00	28.9	25.0	40.1	45	-	37	70												
-	-	-	13.8	20	-	14	70												
CRHEATER215A00	5.8	5.0	13.8	20	-	14	70												
CRHEATER216A00	8.7	7.5	14.9	20	-	14	70												
CRHEATER217A00	11.5	10.0	18.4	20	-	17	70												
CRHEATER218A00	17.3	15.0	25.6	30	-	24	70												
CRHEATER219A00	23.1	20.0	32.9	35	-	30	70												
CRHEATER220A00	28.9	25.0	40.1	45	-	37	70												

13

Table 5 – Electrical Data - Units With Optional Convenience Outlet

50PD UNIT SIZE	NOMINAL POWER SUPPLY V-Ph-Hz	VOLTAGE RANGE		COMPRESSOR		OFM		CONV OUTLET	PWR EXH (FLA)	IFM		ELECTRIC HEAT			POWER SUPPLY		SINGLE POINT KIT	DISCONNECT SIZE		
		Min	Max	RLA	LRA	Qty	FLA			TYPE	FLA	Part Number	FLA	Nom. kW	MCA	MOCP		FLA	LRA	
05	208/230-3-60	187	253	16.1	110	1	1.0	YES	-	STD	5.2	none	-	-	31.1/31.1	45/45	-	31/31	147/147	
												CRHEATER208A00	10.0/11.5	3.8/5.0	31.1/31.1	45/45	-	31/31	147/147	
												CRHEATER209A00	15.0/17.3	5.6/7.5	31.3/34.1	45/45	-	31/31	147/147	
												CRHEATER210A00	20.0/23.1	7.5/10.0	37.5/41.4	45/45	-	35/38	147/147	
												CRHEATER211A00	30.0/34.6	11.3/15.0	50.0/55.8	60/60	-	46/51	147/147	
												CRHEATER212A00	40.0/46.2	15.0/20.0	62.5/70.3	70/80	031	58/65	147/147	
											ALT	5.2	none	-	-	31.1/31.1	45/45	-	31/31	147/147
													CRHEATER208A00	10.0/11.5	3.8/5.0	31.1/31.1	45/45	-	31/31	147/147
													CRHEATER209A00	15.0/17.3	5.6/7.5	31.3/34.1	45/45	-	31/31	147/147
													CRHEATER210A00	20.0/23.1	7.5/10.0	37.5/41.4	45/45	-	35/38	147/147
													CRHEATER211A00	30.0/34.6	11.3/15.0	50.0/55.8	60/60	-	46/51	147/147
													CRHEATER212A00	40.0/46.2	15.0/20.0	62.5/70.3	70/80	031	58/65	147/147
										STD	5.2	none	-	-	32.5/32.5	45/45	-	33/33	149/149	
												CRHEATER208A00	10.0/11.5	3.8/5.0	32.5/32.5	45/45	-	33/33	149/149	
												CRHEATER209A00	15.0/17.3	5.6/7.5	33.0/35.9	45/45	-	33/33	149/149	
												CRHEATER210A00	20.0/23.1	7.5/10.0	39.3/43.1	45/45	-	36/40	149/149	
												CRHEATER211A00	30.0/34.6	11.3/15.0	51.8/57.5	60/60	-	48/53	149/149	
												CRHEATER212A00	40.0/46.2	15.0/20.0	64.3/72.0	70/80	031	59/66	149/149	
											ALT	5.2	none	-	-	32.5/32.5	45/45	-	33/33	149/149
													CRHEATER208A00	10.0/11.5	3.8/5.0	32.5/32.5	45/45	-	33/33	149/149
													CRHEATER209A00	15.0/17.3	5.6/7.5	33.0/35.9	45/45	-	33/33	149/149
													CRHEATER210A00	20.0/23.1	7.5/10.0	39.3/43.1	45/45	-	36/40	149/149
													CRHEATER211A00	30.0/34.6	11.3/15.0	51.8/57.5	60/60	-	48/53	149/149
													CRHEATER212A00	40.0/46.2	15.0/20.0	64.3/72.0	70/80	031	59/66	149/149
	460-3-60	414	506	6.2	52	1	0.5	YES	-	STD	2.6	none	-	-	13.1	15	-	13	70	
												CRHEATER215A00	5.8	5.0	13.3	15	-	13	70	
												CRHEATER216A00	8.7	7.5	16.9	20	-	16	70	
												CRHEATER217A00	11.5	10.0	20.4	25	-	19	70	
												CRHEATER218A00	17.3	15.0	27.6	30	-	25	70	
												CRHEATER219A00	23.1	20.0	34.9	35	-	32	70	
											ALT	2.6	none	-	-	13.1	15	-	13	70
													CRHEATER215A00	5.8	5.0	13.3	15	-	13	70
													CRHEATER216A00	8.7	7.5	16.9	20	-	16	70
													CRHEATER217A00	11.5	10.0	20.4	25	-	19	70
													CRHEATER218A00	17.3	15.0	27.6	30	-	25	70
													CRHEATER219A00	23.1	20.0	34.9	35	-	32	70
										STD	2.6	none	-	-	13.7	20	-	14	71	
												CRHEATER215A00	5.8	5.0	11.5	15	-	11	69	
												CRHEATER216A00	8.7	7.5	14.9	15	-	14	69	
												CRHEATER217A00	11.5	10.0	18.4	20	-	17	69	
												CRHEATER218A00	17.3	15.0	25.6	30	-	24	69	
												CRHEATER219A00	23.1	20.0	32.9	35	-	30	69	
											ALT	2.6	none	-	-	13.7	20	-	14	71
													CRHEATER215A00	5.8	5.0	14.0	20	-	14	71
													CRHEATER216A00	8.7	7.5	17.6	20	-	16	71
													CRHEATER217A00	11.5	10.0	21.1	25	-	19	71
													CRHEATER218A00	17.3	15.0	28.4	30	-	26	71
													CRHEATER219A00	23.1	20.0	35.6	40	-	33	71

Table 5 - Electrical Data - Units With Optional Convenience Outlet (cont)

50PD UNIT SIZE	NOMINAL POWER SUPPLY V-Ph-Hz	VOLTAGE RANGE		COMPRESSOR		OFM		CONV OUTLET	PWR EXH (FLA)	IFM		ELECTRIC HEAT			POWER SUPPLY		SINGLE POINT KIT	DISCONNECT SIZE		
		Min	Max	RLA	LRA	Qty	FLA			TYPE	FLA	Part Number	FLA	Nom. kW	MCA	MOCP		FLA	LRA	
06	208/230-3-60	187	253	17.9	110	1	1.5	YES	-	STD	5.2	none	-	-	33.9/33.9	50/50	-	34/34	148/148	
												CRHEATER208A00	10.0/11.5	3.8/5.0	33.9/33.9	50/50	-	34/34	148/148	
												CRHEATER209A00	15.0/17.3	5.6/7.5	33.9/34.1	50/50	-	34/34	148/148	
												CRHEATER210A00	20.0/23.1	7.5/10.0	37.5/41.4	50/50	-	35/38	148/148	
												CRHEATER211A00	30.0/34.6	11.3/15.0	50.0/55.8	60/60	-	46/51	148/148	
												CRHEATER212A00	40.0/46.2	15.0/20.0	62.5/70.3	70/80	031	58/65	148/148	
												CRHEATER213A00	50.0/57.7	18.8/25.0	75.0/84.6	80/90	031	69/78	148/148	
												none	-	-	33.9/33.9	50/50	-	34/34	148/148	
												CRHEATER208A00	10.0/11.5	3.8/5.0	33.9/33.9	50/50	-	34/34	148/148	
												CRHEATER209A00	15.0/17.3	5.6/7.5	33.9/34.1	50/50	-	34/34	148/148	
												CRHEATER210A00	20.0/23.1	7.5/10.0	37.5/41.4	50/50	-	35/38	148/148	
												CRHEATER211A00	30.0/34.6	11.3/15.0	50.0/55.8	60/60	-	46/51	148/148	
										CRHEATER212A00	40.0/46.2	15.0/20.0	62.5/70.3	70/80	031	58/65	148/148			
										CRHEATER213A00	50.0/57.7	18.8/25.0	75.0/84.6	80/90	031	69/78	148/148			
										ALT	5.2	none	-	-	33.9/33.9	50/50	-	34/34	148/148	
												CRHEATER208A00	10.0/11.5	3.8/5.0	33.9/33.9	50/50	-	34/34	148/148	
												CRHEATER209A00	15.0/17.3	5.6/7.5	33.9/34.1	50/50	-	34/34	148/148	
												CRHEATER210A00	20.0/23.1	7.5/10.0	37.5/41.4	50/50	-	35/38	148/148	
												CRHEATER211A00	30.0/34.6	11.3/15.0	50.0/55.8	60/60	-	46/51	148/148	
												CRHEATER212A00	40.0/46.2	15.0/20.0	62.5/70.3	70/80	031	58/65	148/148	
												CRHEATER213A00	50.0/57.7	18.8/25.0	75.0/84.6	80/90	031	69/78	148/148	
												none	-	-	35.3/35.3	50/50	-	35/35	150/150	
												CRHEATER208A00	10.0/11.5	3.8/5.0	35.3/35.3	50/50	-	35/35	150/150	
												CRHEATER209A00	15.0/17.3	5.6/7.5	35.3/35.9	50/50	-	35/35	150/150	
	CRHEATER210A00	20.0/23.1	7.5/10.0	39.3/43.1	50/50	-	36/40	150/150												
	CRHEATER211A00	30.0/34.6	11.3/15.0	51.8/57.5	60/60	-	48/53	150/150												
	STD	5.2	none	-	-	35.3/35.3	50/50	-	35/35	150/150										
			CRHEATER208A00	10.0/11.5	3.8/5.0	35.3/35.3	50/50	-	35/35	150/150										
			CRHEATER209A00	15.0/17.3	5.6/7.5	35.3/35.9	50/50	-	35/35	150/150										
			CRHEATER210A00	20.0/23.1	7.5/10.0	39.3/43.1	50/50	-	36/40	150/150										
			CRHEATER211A00	30.0/34.6	11.3/15.0	51.8/57.5	60/60	-	48/53	150/150										
			CRHEATER212A00	40.0/46.2	15.0/20.0	64.3/72.0	70/80	031	59/66	150/150										
			CRHEATER213A00	50.0/57.7	18.8/25.0	76.8/86.4	80/90	031	71/79	150/150										
			none	-	-	35.3/35.3	50/50	-	35/35	150/150										
			CRHEATER208A00	10.0/11.5	3.8/5.0	35.3/35.3	50/50	-	35/35	150/150										
			CRHEATER209A00	15.0/17.3	5.6/7.5	35.3/35.9	50/50	-	35/35	150/150										
			CRHEATER210A00	20.0/23.1	7.5/10.0	39.3/43.1	50/50	-	36/40	150/150										
			CRHEATER211A00	30.0/34.6	11.3/15.0	51.8/57.5	60/60	-	48/53	150/150										
	CRHEATER212A00	40.0/46.2	15.0/20.0	64.3/72.0	70/80	031	59/66	150/150												
	CRHEATER213A00	50.0/57.7	18.8/25.0	76.8/86.4	80/90	031	71/79	150/150												
	460-3-60	414	506	7.8	52	1	0.8	YES	-	-	STD	2.6	none	-	-	15.4	20	-	15	71
													CRHEATER215A00	5.8	5.0	15.4	20	-	15	71
													CRHEATER216A00	8.7	7.5	16.9	20	-	16	71
													CRHEATER217A00	11.5	10.0	20.4	25	-	19	71
													CRHEATER218A00	17.3	15.0	27.6	30	-	25	71
													CRHEATER219A00	23.1	20.0	34.9	35	-	32	71
											CRHEATER220A00	28.9	25.0	42.1	45	-	39	71		
											ALT	2.6	none	-	-	15.4	20	-	15	71
CRHEATER215A00													5.8	5.0	15.4	20	-	15	71	
CRHEATER216A00													8.7	7.5	16.9	20	-	16	71	
CRHEATER217A00													11.5	10.0	20.4	25	-	19	71	
CRHEATER218A00													17.3	15.0	27.6	30	-	25	71	
CRHEATER219A00		23.1	20.0	34.9	35	-	32	71												
CRHEATER220A00		28.9	25.0	42.1	45	-	39	71												
STD		2.6	none	-	-	16.0	20	-	16	72										
			CRHEATER215A00	5.8	5.0	16.0	20	-	16	72										
			CRHEATER216A00	8.7	7.5	17.6	20	-	16	72										
			CRHEATER217A00	11.5	10.0	21.1	25	-	19	72										
			CRHEATER218A00	17.3	15.0	28.4	30	-	26	72										
			CRHEATER219A00	23.1	20.0	35.6	40	-	33	72										
		CRHEATER220A00	28.9	25.0	42.9	45	-	39	72											
		ALT	2.6	none	-	-	16.0	20	-	16	72									
				CRHEATER215A00	5.8	5.0	16.0	20	-	16	72									
				CRHEATER216A00	8.7	7.5	17.6	20	-	16	72									
	CRHEATER217A00			11.5	10.0	21.1	25	-	19	72										
	CRHEATER218A00			17.3	15.0	28.4	30	-	26	72										
CRHEATER219A00	23.1			20.0	35.6	40	-	33	72											
CRHEATER220A00	28.9	25.0	42.9	45	-	39	72													

15

LEGEND

- FLA – Full Load Amps
- HACR – Heating, Air Conditioning and Refrigeration
- IFM – Indoor (Evaporator) Fan Motor
- LRA – Locked Rotor Amps
- MCA – Minimum Circuit Amps
- MOCP – Maximum Overcurrent Protection
- NEC – National Electrical Code
- OFM – Outdoor (Condenser) Fan Motor
- RLA – Rated Load Amps



† Fuse or Breaker

NOTES:

1. In compliance with NEC requirements for multimotor and combination load equipment (refer to NEC Articles 430 and 440), the overcurrent protective device for the unit shall be fuse or HACR breaker. Canadian units may be fuse or circuit breaker.
2. **Unbalanced 3-Phase Supply Voltage**  
 Never operate a motor where a phase imbalance in supply voltage is greater than 2%. Use the following formula to determine the percentage of voltage imbalance.

$$\% \text{ Voltage Imbalance} = 100 \times \frac{\text{max voltage deviation from average voltage}}{\text{average voltage}}$$

Example: Supply voltage is 230–3–60



AB = 224 v  
 BC = 231 v  
 AC = 226 v

$$\begin{aligned} \text{Average Voltage} &= \frac{224 + 231 + 226}{3} \\ &= \frac{681}{3} \\ &= 227 \end{aligned}$$

Determine maximum deviation from average voltage.

- (AB) 227 – 224 = 3 v
  - (BC) 231 – 227 = 4 v
  - (AC) 227 – 226 = 1 v
- Maximum deviation is 4 v.

Determine percent of voltage imbalance.

$$\begin{aligned} \% \text{ Voltage Imbalance} &= 100 \times \frac{4}{227} \\ &= 1.76\% \end{aligned}$$

This amount of phase imbalance is satisfactory as it is below the maximum allowable 2%.

**IMPORTANT:** If the supply voltage phase imbalance is more than 2%, contact your local electric utility company immediately.



## Step 7 — Install Outdoor Air Hoods (Units With Economizer)

Perform the following procedure to install the outdoor-air hoods:

1. Economizer and barometric relief hoods are located in the condenser section under the slanted coil for shipping. (See Fig. 9.) Barometric relief/power exhaust hood is shipped inside of economizer hood. Remove screws that secure the wooden rails of the hood assemblies to the unit. Save screws. Slide complete assembly from condenser section.
2. Remove the screws that secure the economizer and barometric relief/power exhaust hoods to the wooden railing. Discard or recycle wooden rails. Save screws.

**NOTE:** The barometric relief damper is secured to the economizer panel for shipping.

**DO NOT THROW THIS PANEL AWAY!**

3. Remove the screw holding the barometric relief damper to the panel. Damper should be free to swing open during operation. (See Fig. 10)

**DO NOT THROW THIS PANEL AWAY!**

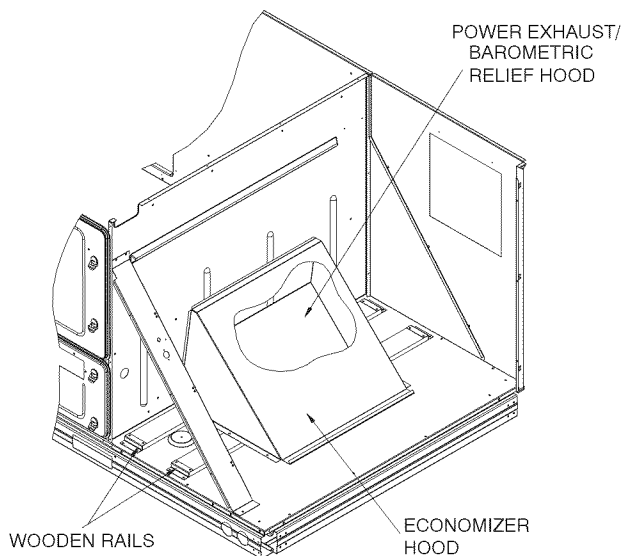
4. Hang the barometric relief/power exhaust hood on the mounting flange on the economizer panel. Secure hood to panel with screws saved from Step 2. (See Fig. 10 and 11.)
5. Align hole in flange of economizer panel with left edge of hood. Hang economizer hood on the top flange of the economizer panel by rotating hood until top flange of the economizer hood engages the bent flange on the economizer panel. Rotate hood until hood is flush with the economizer panel. Hood will support itself from flange. Align holes in hood with holes in panel and secure hood to panel with screws saved from Step 2. (See Fig. 10 and 12.)

## Step 8 — Install All Accessories

After all of the factory-installed options have been adjusted, install all field-installed accessories. Refer to the accessory installation instructions included with each accessory.

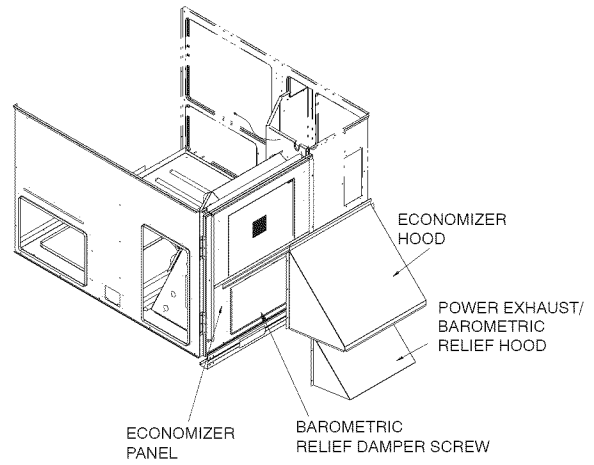
## Step 9 — Configure Controls

Refer to unit controls and Troubleshooting book for information on configuring controls.



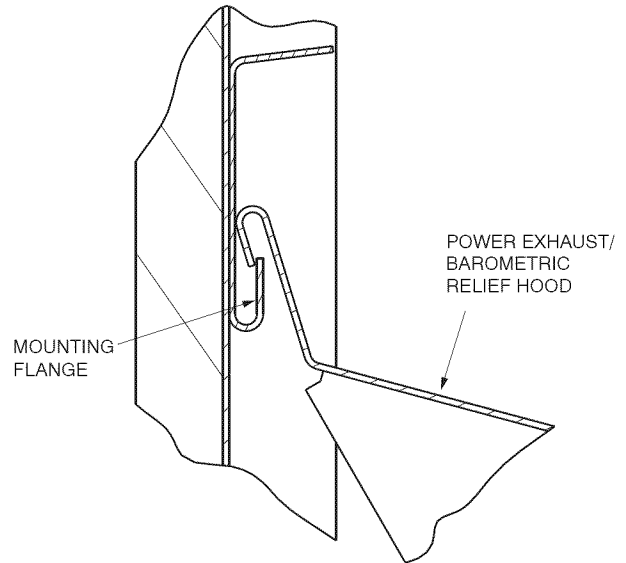
C06290

**Fig. 9 - Economizer and Barometric Relief/Power Hoods Shipping Position**



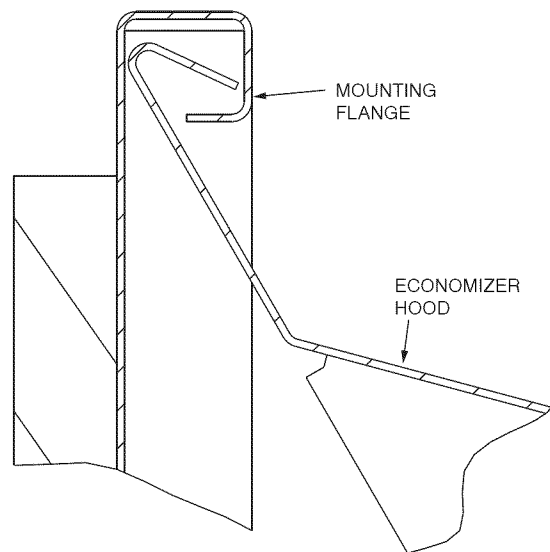
C06260

**Fig. 10 - Hood Installation**



C06262

**Fig. 11 - Barometric Relief/Power Exhaust Hood Flange**



C06263

**Fig. 12 - Economizer Flange**





