



Installation, Start-Up, and Service Instructions

CONTENTS

	Page	Page	
SAFETY CONSIDERATIONS	2	START-UP	35-42
GENERAL	2	Operating Limits	35
INSTALLATION	2-31	Scroll Compressor Rotation	35
Step 1 — Check Jobsite	2	Unit Start-Up Cooling Mode	35
Step 2 — Check Unit	3	Unit Start-Up Heating Mode	36
• STORAGE		Unit Start-Up with WSHP Open Controls	40
• PROTECTION		Flow Regulation	41
• INSPECT UNIT		Flushing	41
Step 3 — Locate Unit	8	Antifreeze	41
• FIELD CONVERSION OF DISCHARGE AIR		Cooling Tower/Boiler Systems	42
Step 4 — Mount the Unit	9	Ground Coupled, Closed Loop and Plateframe	
• HORIZONTAL UNIT		Heat Exchanger Well Systems	42
• VERTICAL UNITS		OPERATION	42-46
Step 5 — Check Duct System	9	Power Up Mode	42
• SOUND ATTENUATION		Units with Aquazone Complete C Control	42
• EXISTING DUCT SYSTEM		Units with Aquazone Deluxe D Control	42
Step 6 — Install Condensate Drain	9	Units with HWR Option	43
• HORIZONTAL UNIT		Units with WSHP Open Multiple Protocol	43
• VERTICAL UNITS		COMPLETE C AND DELUXE D BOARD	
• VENTING		SYSTEM TEST	46,47
Step 7 — Pipe Connections	10	Test Mode	46
• WATER LOOP APPLICATIONS		WSHP Open Test Mode	47
• GROUND-WATER APPLICATIONS		Retry Mode	47
• GROUND-LOOP APPLICATIONS		Aquazone Deluxe D Control LED Indicators	47
• INSTALLATION OF SUPPLY AND RETURN HOSE KIT		SERVICE	48,49
Step 8 — Wire Field Power Supply	13	Filters	48
• POWER CONNECTION		Water Coil	48
• SUPPLY VOLTAGE		Condensate Drain Pans	48
• 208-VOLT OPERATION		Refrigerant System	48
• 460-VOLT OPERATION		Compressor	48
Step 9 — Wire Field Controls	27	Fan Motors	48
• THERMOSTAT CONNECTIONS		Condensate Drain Cleaning	48
• WATER FREEZE PROTECTION		Air Coil Cleaning	48
• AIR COIL FREEZE PROTECTION		Condenser Cleaning	48
• ACCESSORY CONNECTIONS		Checking System Charge	49
• WATER SOLENOID VALVES		Refrigerant Charging	49
• WSHP OPEN WIRING		Air Coil Fan Motor Removal	49
Step 10 — Operate ECM Interface Board	29	Replacing the WSHP Open Controller's Battery	49
• COOLING		TROUBLESHOOTING	49-57
• HEATING		Control Sensors	49
• CFM ADJUST		Thermistor	49
• DEHUMIDIFICATION MODE		WSHP Open Controller	50
PRE-START-UP	32	Thermostatic Expansion Valves	50
System Checkout	32	Stopped or Malfunctioned ECM Motor	54
FIELD SELECTABLE INPUTS	32-35	Moisture Check	55
Complete C Control Jumper Settings	32	APPENDIX A — WSHP OPEN SCREEN CONFIGURATION	58-63
Deluxe D Control Jumper Settings	32	50PSH,PSV,PSD START-UP CHECKLIST	CL-1, CL-2
Complete C Control DIP Switches	32		
Deluxe D Control DIP Switches	32		
Units with Modulating Hot Water Reheat (HWR) Option	33		
Deluxe D Control Accessory Relay Configurations	35		

IMPORTANT: Read the entire instruction manual before starting installation.

SAFETY CONSIDERATIONS

Installation and servicing of air-conditioning equipment can be hazardous due to system pressure and electrical components. Only trained and qualified service personnel should install, repair, or service air-conditioning equipment.

Untrained personnel can perform basic maintenance functions such as cleaning coils and filters and replacing filters. All other operations should be performed by trained service personnel. When working on air-conditioning equipment, observe precautions in the literature, tags and labels attached to the unit, and other safety precautions that may apply.

Improper installation, adjustment, alteration, service, maintenance, or use can cause explosion, fire, electrical shock or other conditions which may cause personal injury or property damage. Consult a qualified installer, service agency, or a local distributor or branch for information or assistance. The qualified installer or agency must use factory-authorized kits or accessories when modifying this product. Refer to the individual instructions packaged with the kits or accessories when installing.

Follow all safety codes. Wear safety glasses and work gloves. Use quenching cloth for brazing operations. Have fire extinguisher available. Read these instructions thoroughly and follow all warnings or cautions attached to the unit. Consult local building codes and the National Electrical Code (NEC) for special installation requirements.

Understand the signal words — DANGER, WARNING, and CAUTION. DANGER identifies the most serious hazards which will result in severe personal injury or death. WARNING signifies hazards that could result in personal injury or death. CAUTION is used to identify unsafe practices, which would result in minor personal injury or product and property damage.

Recognize safety information. This is the safety-alert symbol () . When this symbol is displayed on the unit and in instructions or manuals, be alert to the potential for personal injury.

WARNING

Electrical shock can cause personal injury or death. Before installing or servicing system, always turn off main power to system. There may be more than one disconnect switch. Turn off accessory heater power if applicable.

GENERAL

This installation and start-up instructions literature is for Aquazone™ single-stage water source heat pump systems.

Water source heat pumps (WSHPs) are single-package horizontally and vertically mounted units with electronic controls designed for year-round cooling and heating. Aquazone WSHPs are available in the following unit configurations:

- 50PSH unit with horizontal airflow and right, left or back discharge
- 50PSV unit with vertical airflow and top discharge
- 50PSD unit with vertical airflow and bottom discharge (downflow)

IMPORTANT: The installation of water source heat pump units and all associated components, parts, and accessories which make up the installation shall be in accordance with the regulations of ALL authorities having jurisdiction and MUST conform to all applicable codes. It is the responsibility of the installing contractor to determine and comply with ALL applicable codes and regulations.

INSTALLATION

Step 1 — Check Jobsite — Installation, operation and maintenance instructions are provided with each unit. Before unit start-up, read all manuals and become familiar with the unit and its operation. Thoroughly check out the system before operation. Complete the inspections and instructions listed below to prepare a unit for installation. See Table 1 for unit physical data.

IMPORTANT: This equipment is designed for indoor installation ONLY. Extreme variations in temperature, humidity and corrosive water or air will adversely affect the unit performance, reliability and service life.

HORIZONTAL UNIT (50PSH) — Horizontal units are designed for indoor installation only. Be sure to allow adequate space around the unit for servicing. Refer to Fig. 1 for an illustration of a typical horizontal installation. See Fig. 2 for overall unit dimensions.

VERTICAL AND DOWNFLOW UNITS (50PSV, PSD) — Vertical units are designed for indoor installations. While vertical units are typically installed in a floor-level closet or a small mechanical room, the unit access guidelines for these units are very similar to those described for horizontal units. See Fig. 3 and 4 for overall dimensions. Refer to Fig. 5 for an example of a typical vertical installation. Refer to Fig. 6 for a sample downflow installation.

CAUTION

To avoid equipment damage, do not use these units as a source of heating or cooling during the construction process. The mechanical components and filters used in these units quickly becomes clogged with construction dirt and debris which may cause system damage.

Table 1 — Physical Data — 50PSH, PSV, PSD018-070 Units

50PS UNIT SIZE	006*	009*	012*	018	024	030	036	042	048	060	070
COMPRESSOR (1 Each)	Rotary			Scroll							
FACTORY CHARGE R-410A (oz)	24	32	34	50	56	58	70	80	80	136	144
ECM FAN MOTOR AND BLOWER											
Fan Motor (Hp)	N/A	N/A	N/A	1/2	1/2	1/2	1/2	1/2	1	1	1
Blower Wheel Size (D x W) (in.)	N/A	N/A	N/A	9 x 7	9 x 7	9 x 7	11 x 10	11 x 10	11 x 10	11 x 10	11 x 10
PSC FAN MOTOR AND BLOWER											
(3 Speeds)											
Fan Motor (Hp)	1/25	1/20	1/8	1/6	1/5	1/3	1/2	1/2	3/4	1	1
High Static Fan Motor (Hp)	N/A	N/A	N/A	1/5	1/3	1/2	1/2	3/4	3/4	1	N/A
Blower Wheel Size (D x W) (in.)	6 x 5	6 x 5	6 x 5	9 x 7	9 x 7	9 x 7	10 x 10	10 x 10	10 x 10	11 x 10	11 x 10
Heat Exchanger Water Volume (gal.)	0.56	0.56	0.56	0.56	0.76	0.76	0.92	1.24	1.24	1.56	1.56
COAXIAL VOLUME (gal.)	.17	.29	.45	.56	.76	.76	.92	1.24	1.24	1.56	1.56
WATER CONNECTION SIZE, FPT (in.)	1/2	1/2	1/2	3/4	3/4	3/4	3/4	1	1	1	1
HWG CONNECTION SIZE, FPT (in.)	N/A	N/A	N/A	1/2	1/2	1/2	1/2	1/2	1/2	1/2	1/2
VERTICAL UPFLOW/DOWNFLOW											
Air Coil Dimensions (H x W) (in.)	16 x 16	16 x 16	16 x 16	24 x 20	28 x 20	28 x 20	28 x 25	32 x 25	32 x 25	36 x 25	36 x 25
Throwaway Filter, Standard 1-in., Qty...Size	1... 16 x 20	1... 16 x 20	1... 16 x 20	1... 24 x 24	1... 28 x 24	1... 28 x 24	1... 28 x 30	2... 16 x 30	2... 16 x 30	16 x 30; 1... 20 x 30	16 x 30; 1... 20 x 30
Weight											
Operating (lb)	126	146	150	252	266	268	327	414	416	441	443
Packaged (lb)	136	156	160	262	276	278	337	424	426	451	453
HORIZONTAL											
Air Coil Dimensions (H x W) (in.)	16 x 16	16 x 16	16 x 16	18 x 27	18 x 31	18 x 31	20 x 35	20 x 40	20 x 40	20 x 45	20 x 45
Throwaway Filter, Standard 1-in., Qty...Size	1... 16 x 20	1... 16 x 20	1... 16 x 20	2... 18 x 18	2... 18 x 18	2... 18 x 18	12 x 20; 1... 20 x 25	18 x 20; 1... 20 x 24	18 x 20; 1... 20 x 24	2... 1... 20 x 24	2... 1... 20 x 24
Weight											
Operating (lb)	136	156	160	257	266	268	327	414	416	441	443
Packaged (lb)	146	166	170	267	276	278	337	424	426	451	453
Corner (lb)											
Left Front	45.0	55.0	56.0	74.7	78.8	79.4	104.4	144.3	145.0	182.3	183.1
Left Rear	33.0	36.0	37.0	66.2	69.9	70.4	83.7	97.7	98.1	78.4	78.8
Right Front	30.0	33.0	34.0	63.6	67.2	67.7	74.9	92.1	92.6	72.5	72.8
Right Rear	28.0	32.0	33.0	47.5	50.2	50.5	64.0	79.9	80.3	107.8	108.3

LEGEND

ECM — Electronically Controlled Motor PSC — Permanent Split Capacitor
 FPT — Female Pipe Thread TXV — Thermostatic Expansion Valve
 HWG — Hot Water Generator

*Unit sizes 006-012 not available on 50PSD unit.

NOTE: All units have spring compressor mountings, TXV expansion devices, and 1/2-in. and 3/4-in. electrical knockouts.

Step 2 — Check Unit — Upon receipt of shipment at the jobsite, carefully check the shipment against the bill of lading. Make sure all units have been received. Inspect the carton or crating of each unit, and inspect each unit for damage. Ensure the shipping company makes proper notation of any shortages or damage on all copies of the freight bill. Concealed damage not discovered during unloading must be reported to the shipping company within 15 days of receipt of shipment.

NOTE: It is the responsibility of the purchaser to file all necessary claims with the shipping company.

1. Be sure that the location chosen for unit installation provides ambient temperatures maintained above freezing. Well water applications are especially susceptible to freezing.
2. Be sure the installation location is isolated from sleeping areas, private offices and other acoustically sensitive spaces.
 NOTE: A sound control accessory package may be used to help eliminate sound in sensitive spaces.
3. Check local codes to be sure a secondary drain pan is not required under the unit.
4. Be sure unit is mounted at a height sufficient to provide an adequate slope of the condensate lines. If an appropriate slope cannot be achieved, a field-supplied condensate pump may be required.
5. Provide sufficient space for duct connection. Do not allow the weight of the ductwork to rest on the unit.
6. Provide adequate clearance for filter replacement and drain pan cleaning. Do not allow piping, conduit, etc. to block filter access.

7. Provide sufficient access to allow maintenance and servicing of the fan and fan motor, compressor and coils. Removal of the entire unit from the closet should not be necessary.
8. Provide an unobstructed path to the unit within the closet or mechanical room. Space should be sufficient to allow removal of unit if necessary.
9. Provide ready access to water valves and fittings, and screwdriver access to unit side panels, discharge collar, and all electrical connections.
10. Where access to side panels is limited, pre-removal of the control box side mounting screws may be necessary for future servicing.

STORAGE — If the equipment is not needed immediately at the jobsite, it should be left in its shipping carton and stored in a clean, dry area of the building or in a warehouse. Units must be stored in an upright position at all times. If carton stacking is necessary, stack units a maximum of 3 high. Do not remove any equipment from its shipping package until it is needed for installation.

PROTECTION — Once the units are properly positioned on the jobsite, cover them with either a shipping carton, vinyl film, or an equivalent protective covering. Cap open ends of pipes stored on the jobsite. This precaution is especially important in areas where painting, plastering, or spraying of fireproof material, etc. is not yet complete. Foreign material that accumulates within the units can prevent proper start-up and necessitate costly clean-up operations.

Before installing any of the system components, be sure to examine each pipe, fitting, and valve, and remove any dirt or foreign material found in or on these components.

CAUTION
DO NOT store or install units in corrosive environments or in locations subject to temperature or humidity extremes (e.g., attics, garages, rooftops, etc.). Corrosive conditions and high temperature or humidity can significantly reduce performance, reliability, and service life. Always move units in an upright position. Tilting units on their sides may cause equipment damage.

INSPECT UNIT — To prepare the unit for installation, complete the procedures listed below:

1. Compare the electrical data on the unit nameplate with ordering and shipping information to verify that the correct unit has been shipped.
2. Do not remove the packaging until the unit is ready for installation.

3. Verify that the unit's refrigerant tubing is free of kinks or dents, and that it does not touch other unit components.
4. Inspect all electrical connections. Be sure connections are clean and tight at their terminations.
5. Loosen compressor bolts until the compressor rides freely on springs. Remove shipping restraints.
6. Remove the four 1/4 in. shipping bolts from compressor support plate (two bolts on each side) to maximize vibration and sound alternation.

CAUTION
Failure to remove shipping brackets from spring-mounted compressors will cause excessive noise and could cause component failure due to added vibration.

7. Remove any blower support cardboard from inlet of the blower.
8. Locate and verify any accessory kit located in compressor and/or blower section.
9. Remove any access panel screws that may be difficult to remove once unit is installed.

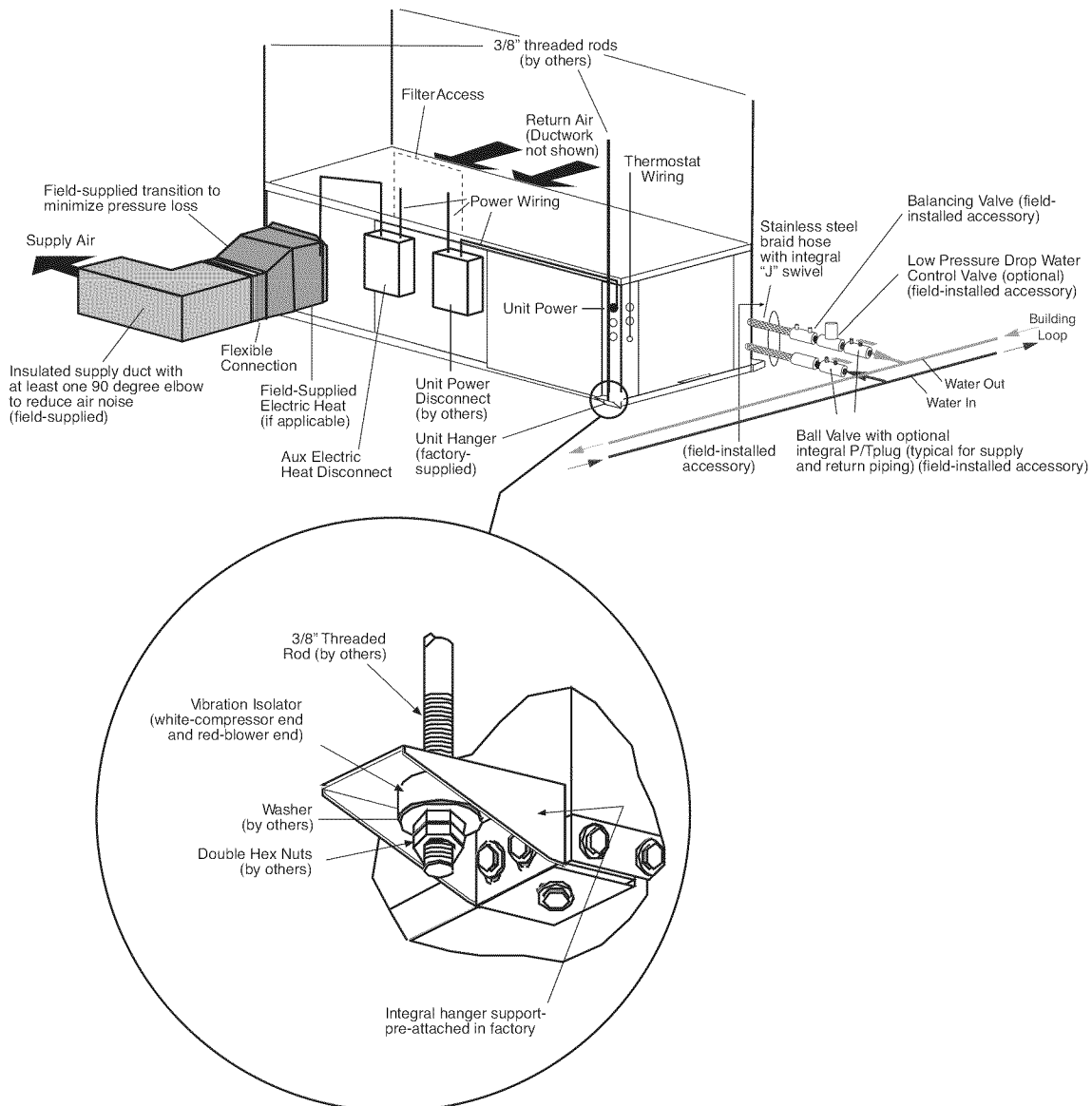

UNIT HANGER ISOLATION DETAIL

Fig. 1 — Typical Installation — 50PSH Unit

50PSH UNIT SIZE	OVERALL CABINET (in.)			WATER CONNECTIONS (in.)								WATER CONNECTIONS (in.) - UNITS WITH HWR		ELECTRICAL KNOCKOUTS (in.)			DISCHARGE CONNECTION (in.) DUCT FLANGE INSTALLED (±0.10 in.)						RETURN CONNECTION (in.) USING RETURN AIR OPENING (±0.10 in.)			
				1	2	3	4	5	Loop Water FPT	HWG FPT	1	2	J 1/2 Cond	K 1/2 Cond	L 3/4 Cond	M (LH rtrn)	N	O Supply Height	P Supply Width	Q (RH rtrn)	R	S Return Depth	T Return Height	U	V	
	A Width	B Depth	C Height	D In	E Out	F HWG In	G HWG Out	H Condensate	Loop In D	Loop Out E	Low Voltage	Ext Pump	Power Supply													
006,009, 012	22.4	43.1	17.3	3.7	9.7	N/A	N/A	0.8	1/2	N/A	N/A	N/A	3.8	6.3	8.8	5.3	4.1	9.0	9.0	5.3	4.1	17.1	15.3	2.1	1.0	
018	22.4	62.2	19.3	2.1	10.0	13.9	16.9	0.6	3/4	1/2	2.1	10.0	3.6	6.1	8.6	3.6	2.0	12.5	15.5	3.6	2.0	28.1	16.2	2.3	1.5	
024, 030	22.4	62.2	19.3	2.1	10.0	13.9	16.9	0.6	3/4	1/2	5.26	13.13	3.6	6.1	8.6	3.6	2.0	12.5	15.5	3.6	2.0	33.8	16.2	2.3	1.5	
036	25.4	71.2	21.3	3.4	10.8	15.6	18.9	0.6	3/4	1/2	5.96	13.13	3.6	6.1	8.6	3.1	1.2	19.0	17.5	3.1	1.0	34.8	18.2	3.1	1.5	
042, 048	25.4	76.2	21.3	3.4	10.8	15.6	18.9	0.6	1	1/2	5.96	13.13	3.6	6.1	8.6	3.1	1.2	19.0	17.5	3.1	1.0	39.8	18.2	3.1	1.5	
060, 070	25.4	81.2	21.3	3.4	10.8	15.6	18.9	0.6	1	1/2	5.96	13.13	3.6	6.1	8.6	3.1	1.2	19.0	17.5	3.1	1.0	44.8	18.2	3.1	1.5	

NOTES:

1. Condensate is 3/4-in. FPT copper.
2. Horizontal unit shipped with filter bracket only. This bracket should be removed for return duct connection.
3. Discharge flange and hanger kit is factory installed.
4. Shaded areas are recommended service areas, not required.

LEGEND

- ASP — Alternate Service Panel
- BSP — Blower Service Panel
- CAP — Control Access Panel
- CSP — Compressor Service Panel
- FPT — Female Pipe Thread
- HWG — Hot Water Generator
- HWR — Hot Water Reheat
- LH — Left Hand
- RH — Right Hand

PSC BLOWER AIRFLOW CONFIGURATION

CODE	RETURN	DISCHARGE
E	Left	Back
B	Right	Back
S	Left	Right
Z	Right	Left

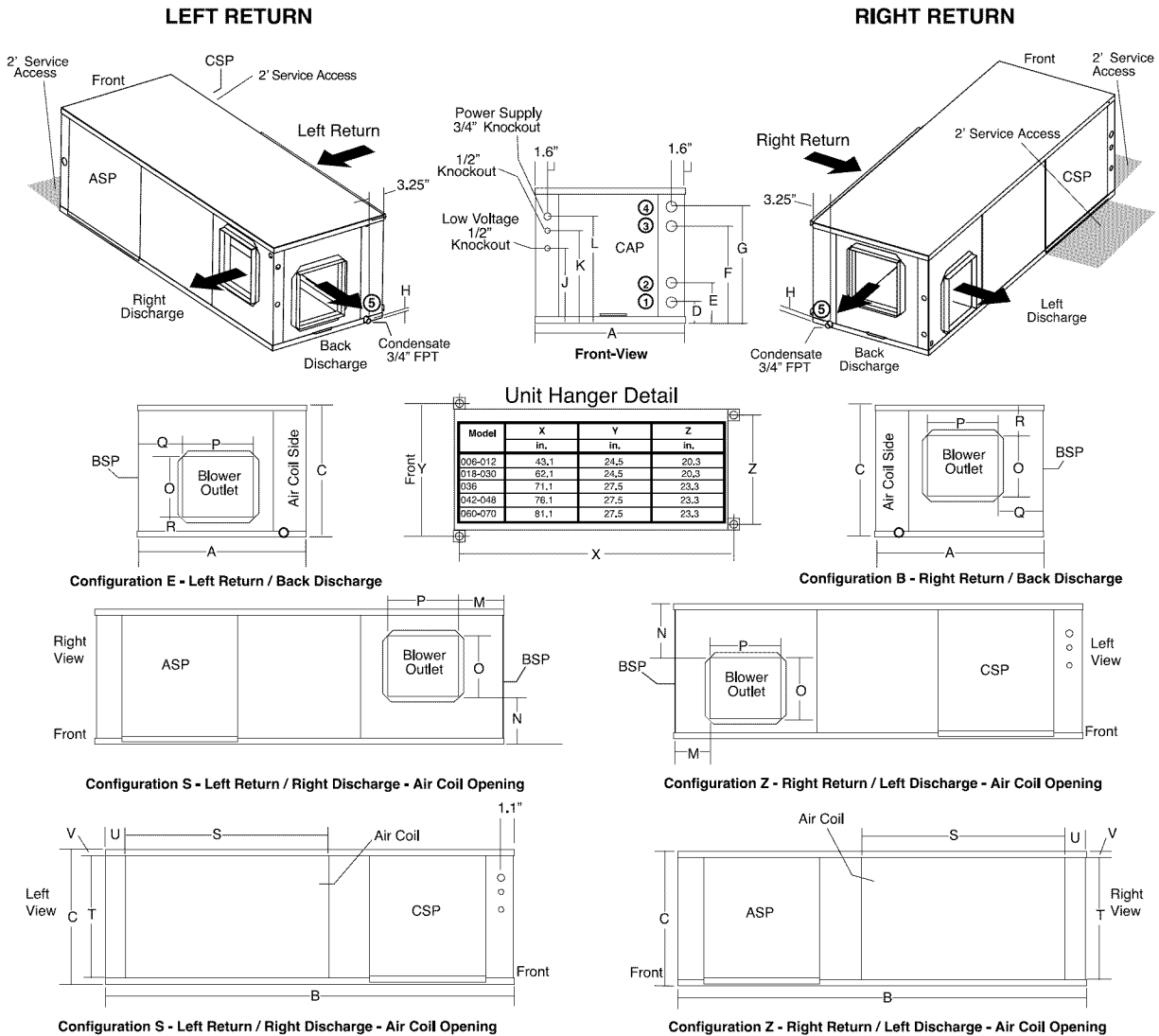

Fig. 2 — 50PSH Dimensional Data

50PSV UNIT SIZE	OVERALL CABINET (in.)			WATER CONNECTIONS (in.)								WATER CONNECTIONS (in.) - UNITS WITH HWR			ELECTRICAL KNOCKOUTS (in.)			DISCHARGE CONNECTION (in.) DUCT FLANGE INSTALLED (±0.10 in.)						RETURN CONNECTION (in.) USING RETURN AIR OPENING (±0.10 in.)		
				1	2	3	4	5	Loop Water FPT	HWG FPT	1	2	J 1/2 Cond	K 1/2 Cond	L 3/4 Cond	M (LH rtrn)	N	O Supply Width	P Supply Depth	Q (RH rtrn)	R	S Return Depth	T Return Height	U		
	A Width	B Depth	C Height	D In	E Out	F HWG In	G HWG Out	H Condensate	Loop Water FPT	HWG FPT	Loop In D	Loop Out E	Low Voltage	Ext Pump	Power Supply											
006,009,012	22.4	21.6	34.5	3.7	9.7	N/A	N/A	7.4	1/2	N/A	N/A	N/A	3.8	6.3	8.8	6.7	6.3	9.0	9.0	6.7	2.3	17.1	15.3	1.0		
018	22.4	25.6	44.6	2.1	10.0	13.9	16.9	7.8	3/4	1/2	2.1	10.0	3.6	6.1	8.6	7.2	5.8	14.0	14.0	4.9	2.2	21.1	23.2	1.0		
024,030	22.4	25.6	48.5	2.1	10.0	13.9	16.9	7.8	3/4	1/2	5.26	13.13	3.6	6.1	8.6	7.2	5.8	14.0	14.0	4.9	2.2	21.1	27.2	1.0		
036	25.4	30.6	50.5	3.4	10.8	15.6	18.9	7.8	3/4	1/2	5.96	13.13	3.6	6.1	8.6	6.4	6.3	18.0	18.0	5.3	2.2	26.1	27.2	1.0		
042,048	25.4	30.6	54.5	3.4	10.8	15.6	18.9	7.8	1	1/2	5.96	13.13	3.6	6.1	8.6	6.4	6.3	18.0	18.0	5.3	2.2	26.1	31.2	1.0		
060,070	25.4	30.6	58.5	3.4	10.8	15.6	18.9	7.8	1	1/2	5.96	13.13	3.6	6.1	8.6	6.4	6.3	18.0	18.0	5.3	2.2	26.1	35.2	1.0		

- NOTES:
1. Condensate is 3/4-in. FPT copper and is switchable from side to front.
 2. Vertical unit shipped with filter bracket only, extending from unit 2.5-in. This bracket should be removed for return duct connection.
 3. Discharge flange field installed.
 4. Shaded areas are recommended service areas, not required.

- LEGEND
- ASP — Alternate Service Panel
 - BSP — Blower Service Panel
 - CAP — Control Access Panel
 - CSP — Compressor Service Panel
 - FPT — Female Pipe Thread
 - HWG — Hot Water Generator
 - HWR — Hot Water Reheat
 - LH — Left Hand
 - RH — Right Hand

PSC BLOWER AIRFLOW CONFIGURATION

CODE	RETURN	DISCHARGE
L	Left	Top
R	Right	Top

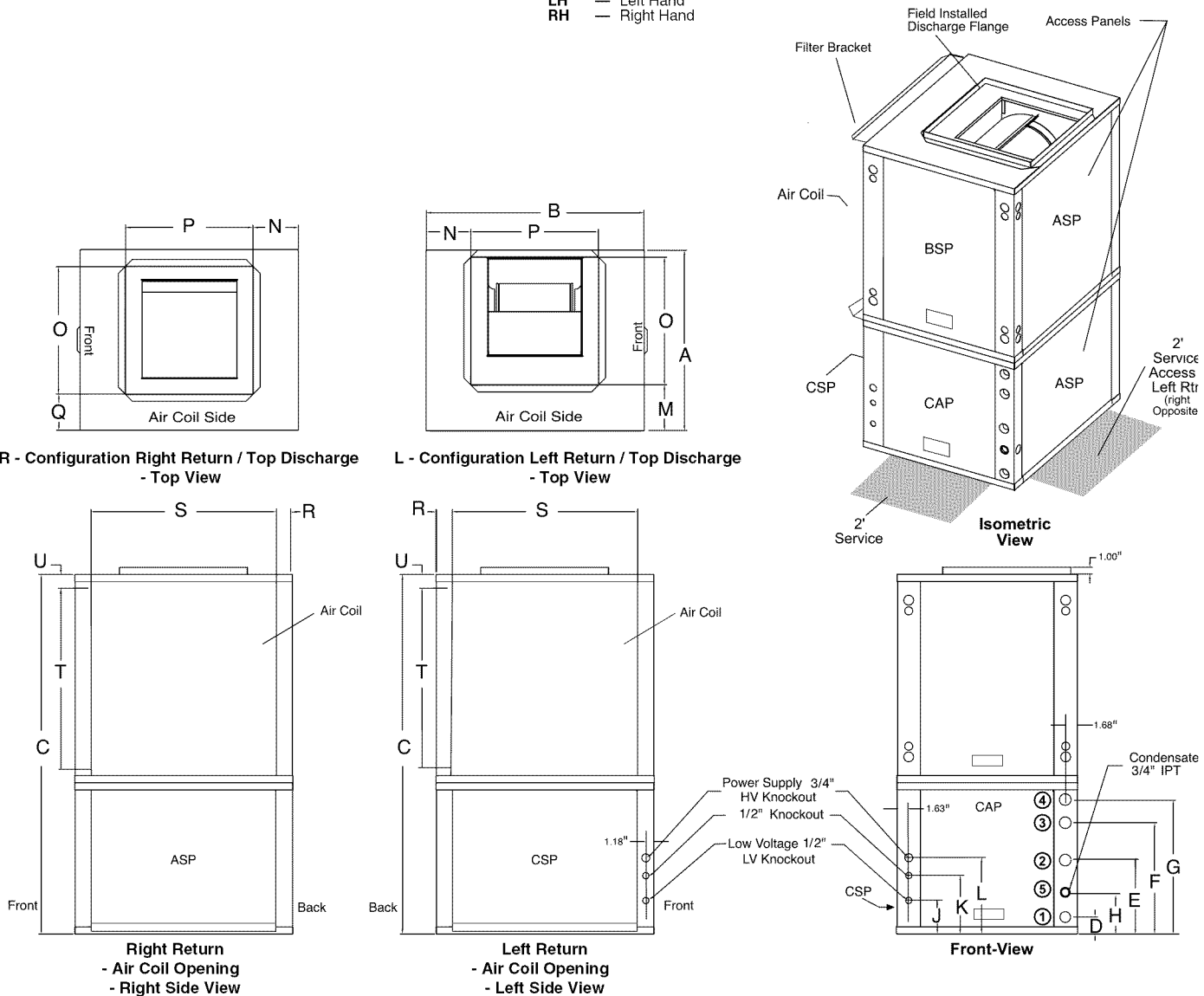

Fig. 3 — 50PSV Dimensional Data

50PSD UNIT SIZE	OVERALL CABINET (in.)			WATER CONNECTIONS (in.)								WATER CONNECTIONS (in.) - UNITS WITH HWR			ELECTRICAL KNOCKOUTS (in.)			DISCHARGE CONNECTION (in.) DUCT FLANGE INSTALLED (±0.10 in.)						RETURN CONNECTION (in.) USING RETURN AIR OPENING (±0.10 in.)		
				1	2	3	4	5	Loop Water FPT	HWG FPT	1	2	J 1/2 Cond	K 1/2 Cond	L 3/4 Cond	M (LH rtrn)	N	O Supply Width	P Supply Depth	Q (RH rtrn)	R	S Return Depth	T Return Height	U		
	A Width	B Depth	C Height	D In	E Out	F HWG In	G HWG Out	H Condensate	Loop In D	Loop Out E	Low Voltage	Ext Pump	Power Supply													
018	22.4	25.6	48.4	2.1	10.0	13.9	16.9	3.6	3/4	1/2	2.1	10.0	3.6	6.1	8.6	6.7	8.4	10.1	9.1	10.8	2.2	21.1	23.2	1.0		
024, 030	22.4	25.6	52.5	2.1	10.0	13.9	16.9	3.6	3/4	1/2	5.96	13.13	3.6	6.1	8.6	6.7	8.4	10.1	9.1	10.8	2.2	21.1	27.2	1.0		
036	25.4	30.6	54.5	3.4	10.8	15.6	18.9	3.6	3/4	1/2	5.96	13.13	3.6	6.1	8.6	7.2	9.0	13.4	12.9	10.4	2.2	26.1	27.2	1.0		
042, 048	25.4	30.6	58.5	3.4	10.8	15.6	18.9	3.6	1	1/2	5.96	13.13	3.6	6.1	8.6	7.2	9.0	13.4	12.9	10.4	2.2	26.1	31.2	1.0		
060, 070	25.4	30.6	62.5	3.4	10.8	15.6	18.9	3.6	1	1/2	5.96	13.13	3.6	6.1	8.6	7.2	9.0	13.4	12.9	10.4	2.2	26.1	35.2	1.0		

NOTES:

1. Condensate is 3/4-in. FPT copper and is switchable from side to front.
2. Vertical unit shipped with filter bracket only, extending from unit 2.5-in. This bracket should be removed for return duct connection.
3. Downflow unit does not have discharge flange, and is rated for zero clearance installation.
4. Shaded areas are recommended service areas, not required.

LEGEND

- ASP — Alternate Service Panel
- BSP — Blower Service Panel
- CAP — Control Access Panel
- CSP — Compressor Service Panel
- FPT — Female Pipe Thread
- HWG — Hot Water Generator
- HWR — Hot Water Reheat
- LH — Left Hand
- RH — Right Hand

PSC BLOWER AIRFLOW CONFIGURATION

CODE	RETURN	DISCHARGE
L	Left	Bottom
R	Right	Bottom

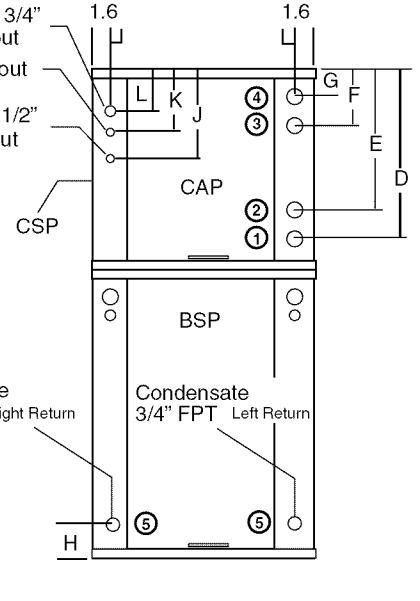
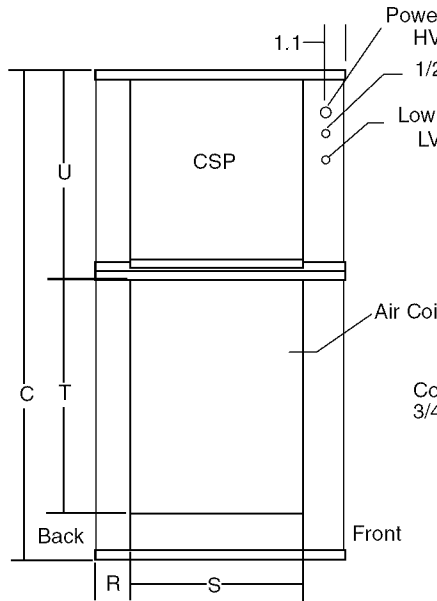
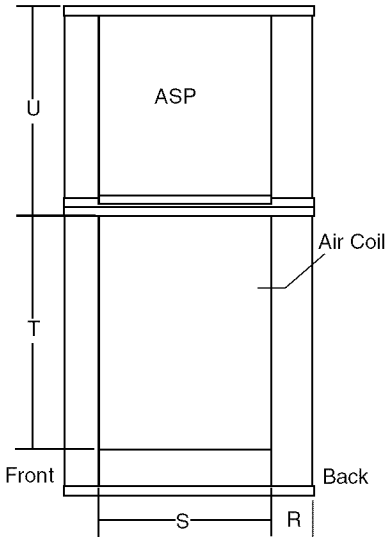
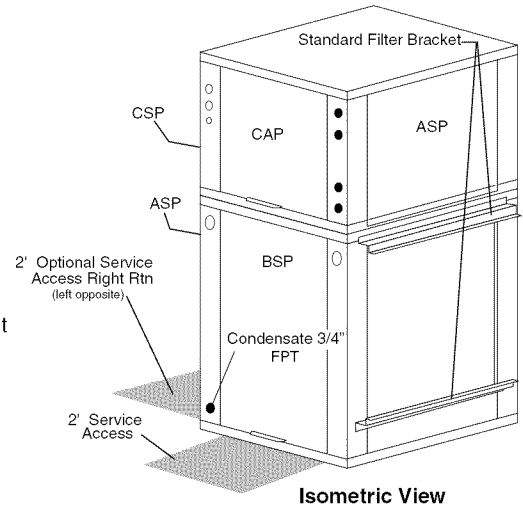
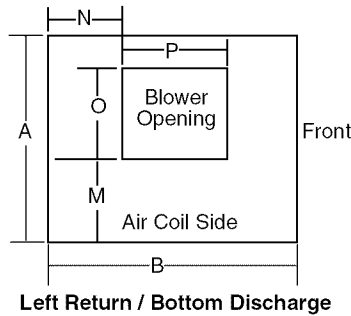
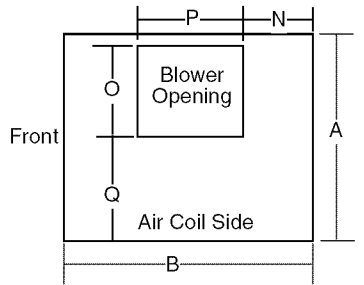
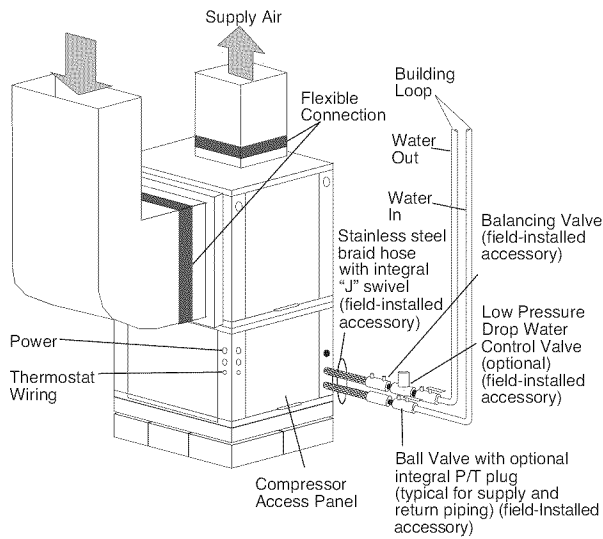
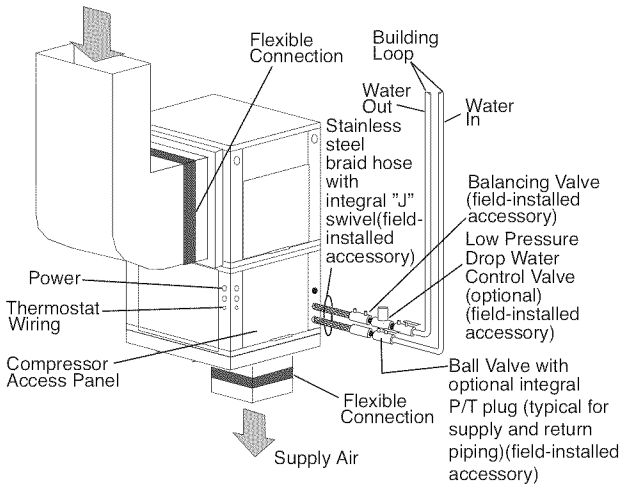

Fig. 4 — 50PSD Dimensional Data



NOTE: Ball valve with integral pressure temperature plug recommended.

Fig. 5 — Typical Vertical Installation — 50PSV Unit



NOTE: Ball valve with integral pressure temperature plug recommended.

Fig. 6 — Typical Downflow Installation — 50PSD Unit

Step 3 — Locate Unit — The following guidelines should be considered when choosing a location for a WSHP:

- Units are for indoor use only.
- Locate in areas where ambient temperatures are between 39 F and 102 F and relative humidity is no greater than 75%.
- Provide sufficient space for water, electrical and duct connections.
- Locate unit in an area that allows easy access and removal of filter and access panels.
- Allow enough space for service personnel to perform maintenance.
- Return air must be able to freely enter the space if unit needs to be installed in a confined area such as a closet.

NOTE: Correct placement of the horizontal unit can play an important part in minimizing sound problems. Since ductwork is normally applied to these units, the unit can be placed so that the principal sound emission is outside the occupied space in sound-critical applications. A fire damper may be required by the local code if a fire wall is penetrated.

FIELD CONVERSION OF DISCHARGE AIR — The discharge air of the 50PSH horizontal units can be converted between side and back discharge in the field. The conversion process is the same for right and left return configurations. See Fig. 7 and 8.

NOTE: It is not possible to convert return air between left or right return models in the field due to refrigerant piping changes.

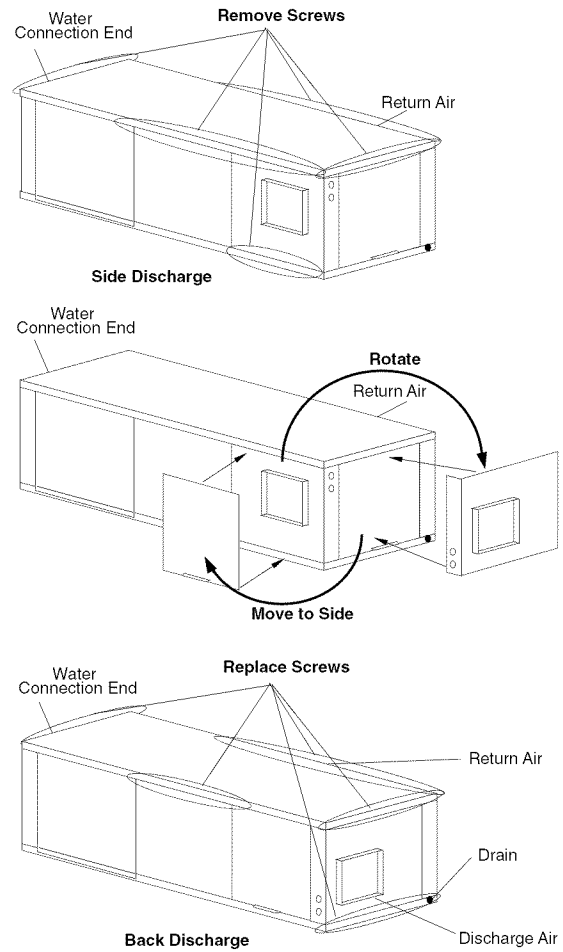

Fig. 7 — Conversion Left Return, Side Discharge to Back Discharge

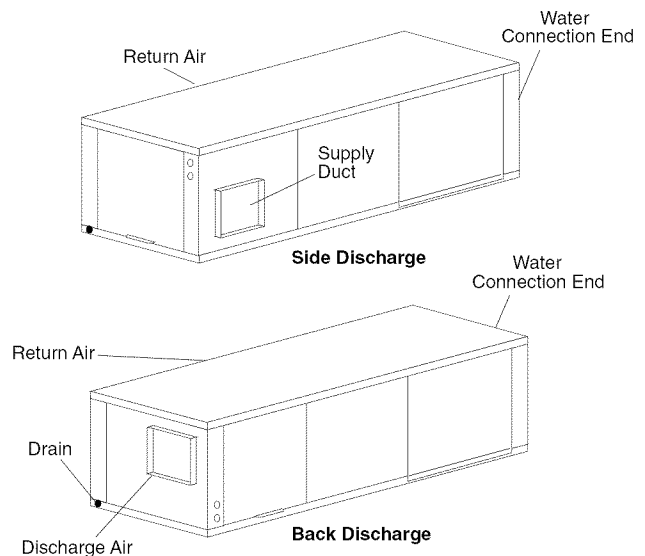

Fig. 8 — Conversion Right Return, Side Discharge to Back Discharge

Preparation — The unit should be on the ground in a well lit area. Hung units should be taken down to ground level before converting.

Side to Back Discharge Conversion

1. Remove screws to free the top and discharge panels. Set screws aside for later use. See Fig. 7.
2. Remove the access panel and set aside.
3. Lift the discharge panel from side of unit and rotate it to back using care not to damage blower wiring.
4. Check blower wire routing and connections for undue tension or contact with sheet metal edges. Re-route if necessary.
5. Check refrigerant tubing for contact with other components. Adjust if necessary.
6. Reinstall top panel using screws set aside in Step 1.
NOTE: Location for some screws at bottom of discharge panel may have to be changed.
7. Manually spin fan wheel to check for obstructions. Adjust for any obstruction found.
8. Replace access panel.

Back to Side Discharge Conversion — Follow instructions above for Side to Back Discharge Conversion, noting the panels would be reversed.

Step 4 — Mount the Unit

HORIZONTAL UNIT (50PSH) — Horizontal units should be mounted using the factory-installed hangers. Proper attachment of hanging rods to building structure is critical for safety. See Fig. 1. Rod attachments must be able to support the weight of the unit. See Table 1 for unit operating weights.

VERTICAL UNITS (50PSV, PSD) — Vertical and downflow units are available in left or right return air configurations. See Fig. 3 and 4. Mount the unit (except 50PSD) on a vibration absorption pad slightly larger than the entire base to minimize vibration transmission. It is not necessary to mount the unit on the floor. See Fig. 9.

NOTE: Some codes require the use of a secondary drain pan under vertical units. Check local codes for more information.

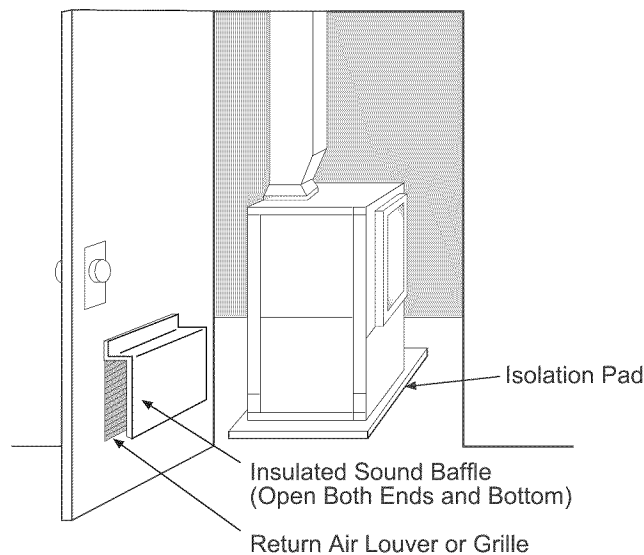

Fig. 9 — 50PSV Units Mounted With Vibration Absorption Pad

Step 5 — Check Duct System — Size the duct system to handle the design airflow quietly.

NOTE: Depending on the unit, the fan wheel may have a shipping support installed at the factory. This must be removed before operating unit.

SOUND ATTENUATION — To eliminate the transfer of vibration to the duct system, a flexible connector is recommended for both discharge and return air duct connections on metal duct systems. The supply and return plenums should include internal duct liner of fiberglass or be made of duct board construction to maximize sound attenuation of the blower. Installing the WSHP unit to uninsulated ductwork in an unconditioned space is not recommended since it will sweat and adversely affect the unit’s performance.

To reduce air noise, at least one 90-degree elbow could be included in the supply and return air ducts, provided system performance is not adversely impacted. The blower speed can also be changed in the field to reduce air noise or excessive airflow, provided system performance is not adversely impacted.

EXISTING DUCT SYSTEM — If the unit is connected to existing ductwork, consider the following:

- Verify that the existing ducts have the proper capacity to handle the unit airflow. If the ductwork is too small, install larger ductwork.
- Check existing ductwork for leaks and repair as necessary.

NOTE: Local codes may require ventilation air to enter the space for proper indoor air quality. Hard-duct ventilation may be required for the ventilating air supply. If hard ducted ventilation is not required, be sure that a proper air path is provided for ventilation air to unit to meet ventilation requirement of the space.

Step 6 — Install Condensate Drain

HORIZONTAL UNIT (50PSH) — Slope the unit toward the drain at 1/4 in. See Fig. 10. If it is not possible to meet the required pitch, install a condensate at the unit to pump condensate to building drain.

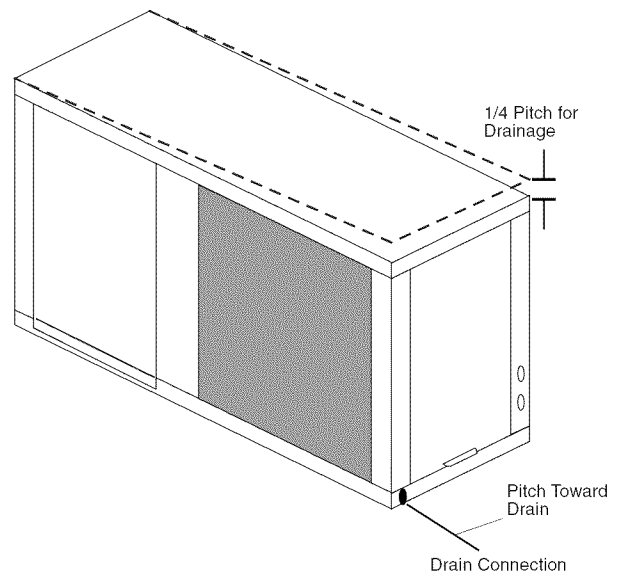
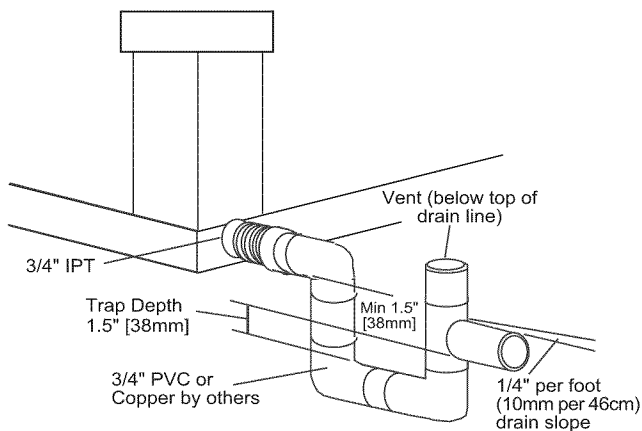

Fig. 10 — Horizontal Unit Pitch

Horizontal units are not internally trapped, therefore an external trap is necessary. Install each unit with its own individual trap and means to flush or blow out the condensate drain line. Do not install units with a common trap or vent. See Fig. 11 for typical condensate connections.

NOTE: Never use a pipe size smaller than the connection.



NOTE: Trap should be deep enough to offset maximum unit static difference. A 4-in. trap is recommended.

Fig. 11 — Trap Condensate Drain Connection

VERTICAL UNITS (50PSV, PSD) — Each unit uses a condensate hose inside all cabinets as a trapping loop, therefore an external trap is not necessary. See Fig. 12.

Each unit must be installed with its own individual vent and means to flush or blow out the condensate drain line. Do not install units with a common trap or vent.

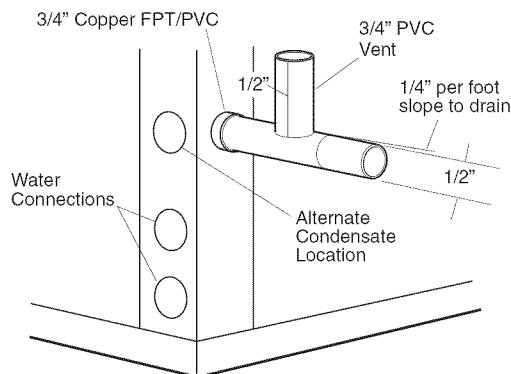

NOTE: Unit does not need to be sloped toward drain.

Fig. 12 — Vertical Condensate Connection

VENTING — Install a vent in the condensate line of any application that may allow dirt or air to collect in the line. Consider the following:

- Always install a vent where an application requires a long horizontal run.
- Always install a vent where large units are working against higher external static pressure and to allow proper drainage for multiple units connected to the same condensate main.
- Be sure to support the line where anticipated sagging from the condensate or when “double trapping” may occur.
- If condensate pump is present on unit, be sure drain connections have a check valve to prevent back flow of condensate into other units.

Step 7 — Pipe Connections — Depending on the application, there are 3 types of WSHP piping systems to choose from: water loop, ground-water and ground loop. Refer to Piping Section of Carrier System Design Manual for additional information.

All WSHP units use low temperature soldered female pipe thread fittings for water connections to prevent annealing and out-of-round leak problems which are typically associated with high temperature brazed connections. Refer to Table 1 for

connection sizes. When making piping connections, consider the following:

- Use a backup wrench when making screw connections to unit to prevent internal damage to piping.
- Insulation may be required on piping to avoid condensation in the case where fluid in loop piping operates at temperatures below dew point of adjacent air.
- Piping systems that contain steel pipes or fittings may be subject to galvanic corrosion. Dielectric fittings may be used to isolate the steel parts of the system to avoid galvanic corrosion.

WATER LOOP APPLICATIONS — Water loop applications usually include a number of units plumbed to a common piping system. Maintenance to any of these units can introduce air into the piping system. Therefore, air elimination equipment comprises a major portion of the mechanical room plumbing.

The flow rate is usually set between 2.25 and 3.5 gpm per ton of cooling capacity. For proper maintenance and servicing, pressure-temperature (P/T) ports are necessary for temperature and flow verification.

Cooling tower/boiler systems typically utilize a common loop maintained at 60 to 95 F. The use of a closed circuit evaporative cooling tower with a secondary heat exchange between the tower and the water loop is recommended. If an open type cooling tower is used continuously, chemical treatment and filtering will be necessary.

In addition to complying with any applicable codes, consider the following for system piping:

- Piping systems using water temperatures below 50 F require 1/2-in. closed cell insulation on all piping surfaces to eliminate condensation.
- Avoid all plastic to metal threaded fittings due to the potential to leak. Use a flange fitted substitute.
- Teflon tape thread sealant is recommended to minimize internal fouling of the heat exchanger.
- Use backup wrench. Do not overtighten connections.
- Route piping to avoid service access areas to unit.
- Flush the piping system prior to operation to remove dirt and foreign materials from the system.

GROUND-WATER APPLICATIONS — Typical ground-water piping is shown in Fig. 13. In addition to complying with any applicable codes, consider the following for system piping:

- Install shut-off valves for servicing.
- Install pressure-temperature plugs to measure flow and temperature.
- Connect boiler drains and other valves using a “T” connector to allow acid flushing for the heat exchanger.
- Do not overtighten connections.
- Route piping to avoid service access areas to unit.
- Use PVC SCH80 or copper piping material.

NOTE: PVC SCH40 should *not* be used due to system high pressure and temperature extremes.

Water Supply and Quantity — Check water supply. Water supply should be plentiful and of good quality. See Table 2 for water quality guidelines.

IMPORTANT: Failure to comply with the above required water quality and quantity limitations and the closed-system application design requirements may cause damage to the tube-in-tube heat exchanger. This damage is not the responsibility of the manufacturer.

Table 2 — Water Quality Guidelines

CONDITION	HX MATERIAL*	CLOSED RECIRCULATING†	OPEN LOOP AND RECIRCULATING WELL**
Scaling Potential — Primary Measurement			
Above the given limits, scaling is likely to occur. Scaling indexes should be calculated using the limits below.			
pH/Calcium Hardness Method	All	N/A	pH < 7.5 and Ca Hardness, <100 ppm
Index Limits for Probable Scaling Situations (Operation outside these limits is not recommended.)			
Scaling indexes should be calculated at 150 F for direct use and HWG applications, and at 90 F for indirect HX use. A monitoring plan should be implemented.			
Ryznar Stability Index	All	N/A	6.0 - 7.5 If >7.5 minimize steel pipe use.
Langelier Saturation Index	All	N/A	-0.5 to +0.5 If <-0.5 minimize steel pipe use. Based upon 150 F HWG and direct well, 85 F indirect well HX.
Iron Fouling			
Iron Fe ²⁺ (Ferrous) (Bacterial Iron Potential)	All	N/A	<0.2 ppm (Ferrous) If Fe ²⁺ (ferrous) >0.2 ppm with pH 6 - 8, O ₂ <5 ppm check for iron bacteria.
Iron Fouling	All	N/A	<0.5 ppm of Oxygen Above this level deposition will occur.
Corrosion Prevention††			
pH	All	6 - 8.5 Monitor/treat as needed.	6 - 8.5 Minimize steel pipe below 7 and no open tanks with pH <8.
Hydrogen Sulfide (H ₂ S)	All	N/A	<0.5 ppm At H ₂ S>0.2 ppm, avoid use of copper and cupronickel piping of HXs. Rotten egg smell appears at 0.5 ppm level. Copper alloy (bronze or brass) cast components are okay to <0.5 ppm.
Ammonia Ion as Hydroxide, Chloride, Nitrate and Sulfate Compounds	All	N/A	<0.5 ppm
Maximum Chloride Levels			Maximum allowable at maximum water temperature.
			50 F (10 C) 75 F (24 C) 100 F (38 C)
	Copper	N/A	<20 ppm NR NR
	Cupronickel	N/A	<150 ppm NR NR
	304 SS	N/A	<400 ppm <250 ppm <150 ppm
	316 SS	N/A	<1000 ppm <550 ppm <375 ppm
	Titanium	N/A	>1000 ppm >550 ppm >375 ppm
Erosion and Clogging			
Particulate Size and Erosion	All	<10 ppm of particles and a maximum velocity of 6 fps. Filtered for maximum 800 micron size.	<10 ppm (<1 ppm "sandfree" for reinjection) of particles and a maximum velocity of 6 fps. Filtered for maximum 800 micron size. Any particulate that is not removed can potentially clog components.
Brackish	All	N/A	Use cupronickel heat exchanger when concentrations of calcium or sodium chloride are greater than 125 ppm are present. (Seawater is approximately 25,000 ppm.)

LEGEND

- HWG** — Hot Water Generator
- HX** — Heat Exchanger
- N/A** — Design Limits Not Applicable Considering Recirculating Potable Water
- NR** — Application Not Recommended
- SS** — Stainless Steel

*Heat exchanger materials considered are copper, cupronickel, 304 SS (stainless steel), 316 SS, titanium.

†Closed recirculating system is identified by a closed pressurized piping system.

**Recirculating open wells should observe the open recirculating design considerations.

††If the concentration of these corrosives exceeds the maximum allowable level, then the potential for serious corrosion problems exists. Sulfides in the water quickly oxidize when exposed to air, requiring that no agitation occur as the sample is taken. Unless tested immediately at the site, the sample will require stabilization with a few drops of one Molar zinc acetate solution, allowing accurate sulfide determination up to 24 hours after sampling. A low pH and high alkalinity cause system problems, even when both values are within ranges shown. The term pH refers to the acidity, basicity, or neutrality of the water supply. Below 7.0, the water is considered to be acidic. Above 7.0, water is considered to be basic. Neutral water contains a pH of 7.0. To convert ppm to grains per gallon, divide by 17. Hardness in mg/l is equivalent to ppm.

In all applications, the quality of the water circulated through the heat exchanger must fall within the ranges listed in the Water Quality Guidelines table. Consult a local water firm, independent testing facility, or local water authority for specific recommendations to maintain water quality within the published limits.

GROUND-LOOP APPLICATIONS — Temperatures between 25 and 110 F and a cooling capacity of 2.25 to 3 gpm of flow per ton is recommended. In addition to complying with any applicable codes, consider the following for system piping:

- Limit piping materials to only polyethylene fusion in the buried sections of the loop.
- Do not use galvanized or steel fittings at any time due to corrosion.
- Avoid all plastic to metal threaded fittings due to the potential to leak. Use a flange fitted substitute.
- Do not overtighten connections.
- Route piping to avoid service access areas to unit.
- Use pressure-temperature (P/T) plugs to measure flow of pressure drop.

INSTALLATION OF SUPPLY AND RETURN HOSE KIT — Follow these piping guidelines.

1. Install a drain valve at the base of each supply and return riser to facilitate system flushing.
2. Install shutoff/balancing valves and unions at each unit to permit unit removal for servicing.
3. Place strainers at the inlet of each system circulating pump.
4. Select the proper hose length to allow slack between connection points. Hoses may vary in length by +2% to -4% under pressure.

5. Refer to Table 3. Do not exceed the minimum bend radius for the hose selected. Exceeding the minimum bend radius may cause the hose to collapse, which reduces water flow rate. Install an angle adapter to avoid sharp bends in the hose when the radius falls below the required minimum.

NOTE: Piping must comply with all applicable codes.

Table 3 — Metal Hose Minimum Bend Radii

HOSE DIAMETER (in.)	MINIMUM BEND RADII (in.)
1/2	2 1/2
3/4	4
1	5 1/2

Insulation is not required on loop water piping except where the piping runs through unheated areas or outside the building or when the loop water temperature is below the minimum expected dew point of the pipe ambient. Insulation is required if loop water temperature drops below the dew point.

IMPORTANT: Do not bend or kink supply lines or hoses.

Pipe joint compound is not necessary when Teflon threaded tape is pre-applied to hose assemblies or when flared-end connections are used. If pipe joint compound is preferred, use compound only in small amounts on the male pipe threads of the fitting adapters. Prevent sealant from reaching the flared surfaces of the joint.

NOTE: When anti-freeze is used in the loop, assure that it is compatible with Teflon tape or pipe joint compound employed.

Maximum allowable torque for brass fittings is 30 ft-lb. If a torque wrench is not available, tighten finger-tight plus one quarter turn. Tighten steel fittings as necessary.

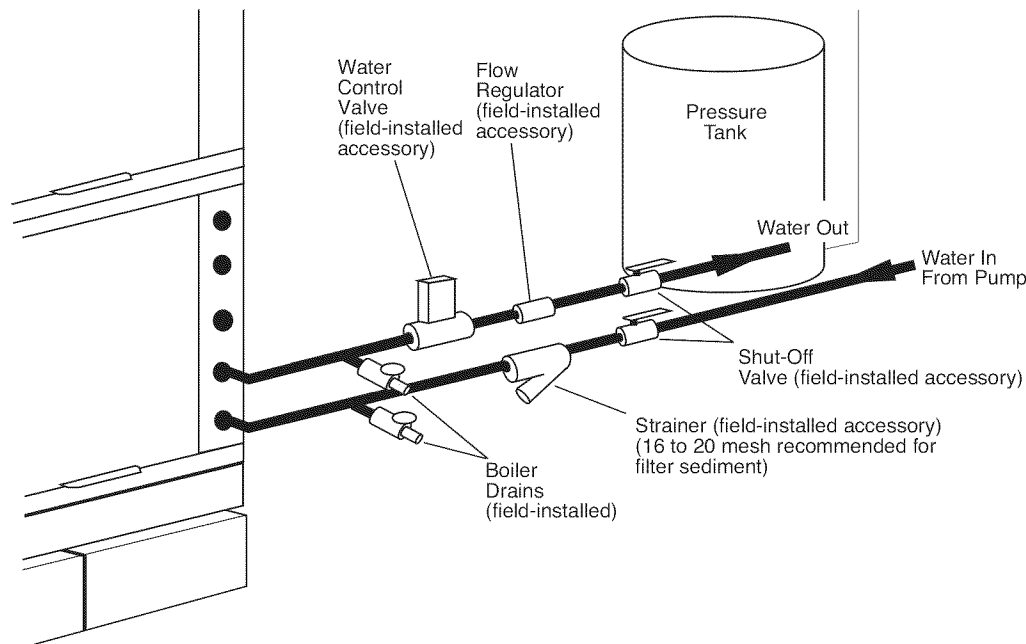

Fig. 13 — Typical Ground-Water Piping Installation

Optional pressure-rated hose assemblies designed specifically for use with Carrier units are available. Similar hoses can be obtained from alternate suppliers. Supply and return hoses are fitted with swivel-joint fittings at one end to prevent kinking during installation.

⚠ CAUTION

Backup wrench is required when tightening water connections to prevent water line damage. Failure to use a backup wrench could result in equipment damage.

Refer to Fig. 14 for an illustration of a supply/return hose kit. Male adapters secure hose assemblies to the unit and risers. Install hose assemblies properly and check them regularly to avoid system failure and reduced service life.

Step 8 — Wire Field Power Supply

⚠ WARNING

To avoid possible injury or death due to electrical shock, open the power supply disconnect switch and secure it in an open position during installation.

⚠ CAUTION

Use only copper conductors for field-installed electrical wiring. Unit terminals are not designed to accept other types of conductors. Failure to use copper conductors could result in equipment damage.

All field-installed wiring, including the electrical ground, MUST comply with the National Electrical Code (NEC) as well as applicable local codes. In addition, all field wiring must conform to the Class II temperature limitations described in the NEC.

Refer to unit wiring diagrams Fig. 15-25 for a schematic of the field connections, which must be made by the installing (or electrical) contractor. Refer to Tables 4-6 for fuse sizes.

Consult the unit wiring diagram located on the inside of the compressor access panel to ensure proper electrical hookup. The installing (or electrical) contractor must make the field connections when using field-supplied disconnect.

Operating voltage must be the same voltage and phase as shown in electrical data shown in Tables 4-6.

Make all final electrical connections with a length of flexible conduit to minimize vibration and sound transmission to the building.

POWER CONNECTION — Make line voltage connection by connecting the incoming line voltage wires to the line side of the compressor contactor terminal as shown in Fig. 26. See Tables 4-6 for amperage ratings to provide correct wire and maximum overcurrent protection sizing.

SUPPLY VOLTAGE — Operating voltage to unit must be within voltage range indicated on unit nameplate.

On 3-phase units, voltages under load between phases must be balanced within 2%. Use the following formula to determine the percentage voltage imbalance:

% Voltage Imbalance

$$= 100 \times \frac{\text{max voltage deviation from average voltage}}{\text{average voltage}}$$

Example: Supply voltage is 460-3-60.

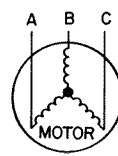

AB = 452 volts
BC = 464 volts
AC = 455 volts

$$\begin{aligned} \text{Average Voltage} &= \frac{452 + 464 + 455}{3} \\ &= \frac{1371}{3} \\ &= 457 \end{aligned}$$

Determine maximum deviation from average voltage:

(AB) 457 - 452 = 5 v
(BC) 464 - 457 = 7 v
(AC) 457 - 455 = 2 v

Maximum deviation is 7 v.

Determine percent voltage imbalance.

$$\begin{aligned} \% \text{ Voltage Imbalance} &= 100 \times \frac{7}{457} \\ &= 1.53\% \end{aligned}$$

This amount of phase imbalance is satisfactory as it is below the maximum allowable 2%.

Operation on improper line voltage or excessive phase imbalance constitutes abuse and may cause damage to electrical components.

NOTE: If more than 2% voltage imbalance is present, contact your local electric utility.

208-VOLT OPERATION — All 208-230 volt units are factory wired for 208 volts. The transformers may be switched to 230-volt operation by switching the red (208 volt) wire with the orange (230 volt) wire at the L1 terminal.

460-VOLT OPERATION — Units using 460-v and an ECM (electronically commutated motor) fan motor, modulating HWR, and/or internal secondary pump will require a neutral wire from the supply side in order to feed accessory with 265-v.

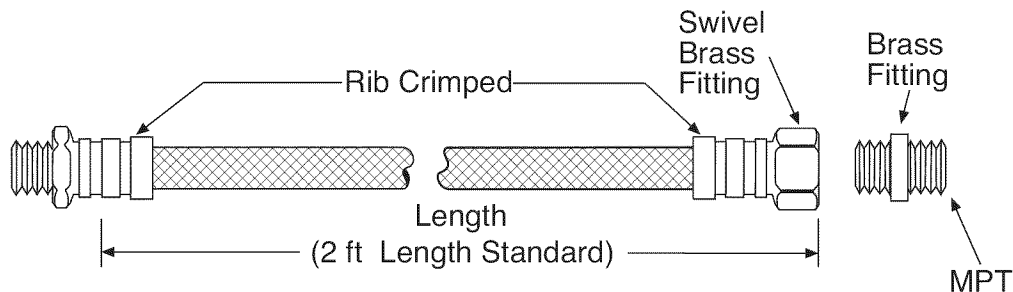
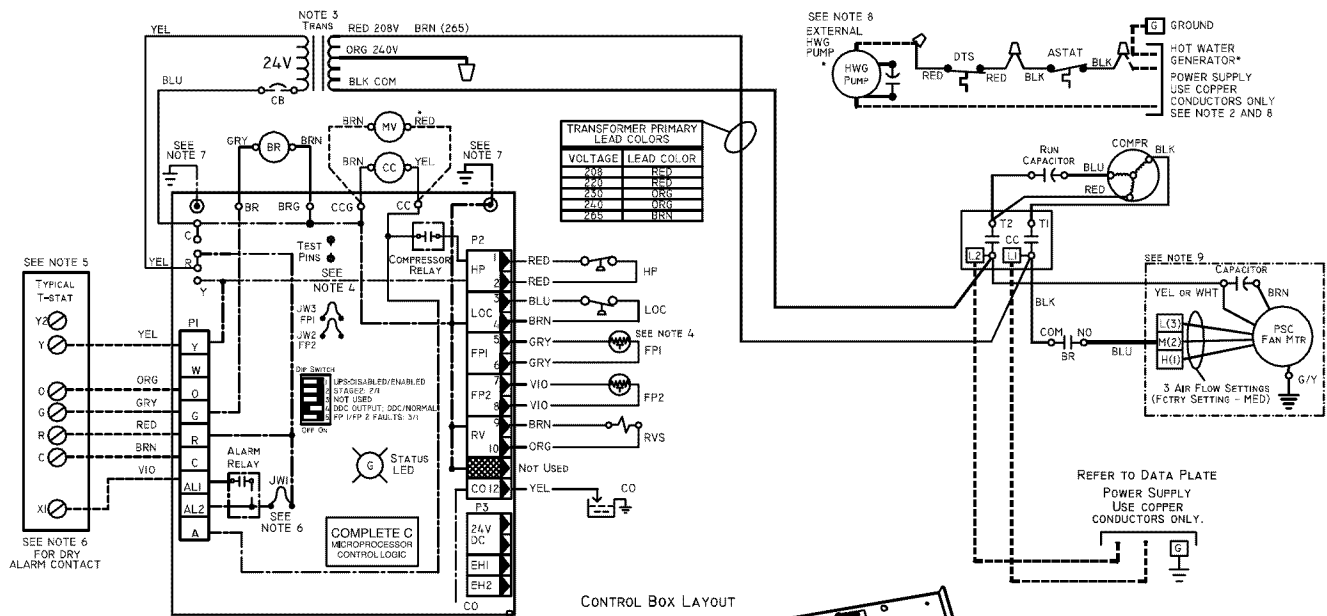

Fig. 14 — Supply/Return Hose Kit



- AL — Alarm Relay Contacts
- ASTAT — Aquastat
- BR — Blower Relay
- CB — Circuit Breaker
- CC — Compressor Contactor
- CO — Condensate Overflow Sensor
- COMPR — Compressor
- DTS — Discharge Temp Switch
- FP1 — Water Coil Freeze Protection Sensor
- FP2 — Air Coil Freeze Protection Sensor
- HP — High-Pressure Switch
- HWG — Hot Water Generator
- JW — Jumper Wire
- LOC — Loss of Charge Pressure Switch
- MV — Motorized Valve
- NEC — National Electrical Code
- PSC — Permanent Split Capacitor
- P1 — Field Wiring Terminal Block
- RVS — Reversing Valve Solenoid

- TRANS — Transformer
- UPS — Unit Performance Sentinel
- Factory Low Voltage Wiring
- Factory Line Voltage Wiring
- Field Low Voltage Wiring
- Field Line Voltage Wiring
- Printed Circuit Trace
- Optional Wiring
- — Relay/Contactor Coil
- ⊞ — Thermistor
- ⊞ — Condensate Pan
- ⊞ — Circuit Breaker

- ⊞ — Solenoid Coil
- ⊞ — Relay Contacts - N.C.
- ⊞ — Relay Contacts - N.O.
- ⊞ — Capacitor
- ⊞ — Temperature Switch
- ⊞ — Low Pressure Switch
- ⊞ — High Pressure Switch
- ⊞ — Wire Nut
- ⊞ — Splice Cap
- ⊞ — LED

*Optional.

- NOTES:
- Compressor and blower motor thermally protected internally.
 - All wiring to the unit must comply with NEC and local codes.
 - 208/230 v transformer will be connected for 208 v operation. For 230 v operation, disconnect RED lead at L1 and attach ORANGE lead to L1. Insulate open end of RED lead. Transformer is energy limiting or may have circuit breaker.
 - FP1 thermistor provides freeze protection for water. When using antifreeze solutions, cut JW3 jumper.
 - Check installation wiring information for specific thermostat hookup. Refer to thermostat installation instructions for wiring to the unit. Thermostat wiring must be "Class 1" and voltage rating equal to or greater than unit supply voltage.
 - 24-v alarm signal shown. For dry alarm contact, cut JW1 jumper and dry contact will be available between AL1 and AL2.
 - Transformer secondary ground via Complete C board standoffs and screws to control box. (Ground available from top two standoffs as shown.)
 - Aquastat is supplied with unit and must be wired in series with the hot leg to the pump. Aquastat is rated for voltage up to 277 v.
 - Fan motors factory wired for medium speed. For high and low speed remove BLU wire from fan motor speed tap 'M' and connect to 'H' for high or 'L' for low.

COMPLETE C CONTROLLER FAULT CODES

DESCRIPTION OF OPERATION	LED	ALARM RELAY
Normal Mode	ON	Open
Normal Mode with UPS Warning	ON	Cycle (Closed 5 Sec. Open 25 Sec.)
Complete C is Non-Functional	OFF	Open
Fault Retry	Slow Flash	Open
Lockout	Fast Flash	Closed
Over/Under Voltage Shutdown	Slow Flash	Open (Closed After 15 Min.)
Test Mode-No Fault in Memory	Flashing Code 1	Cycling Code 1
Test Mode-HP Fault in Memory	Flashing Code 2	Cycling Code 2
Test Mode-LP Fault in Memory	Flashing Code 3	Cycling Code 3
Test Mode-FP1 Fault in Memory	Flashing Code 4	Cycling Code 4
Test Mode-FP2 Fault in Memory	Flashing Code 5	Cycling Code 5
Test Mode-CO Fault in Memory	Flashing Code 6	Cycling Code 6
Test Mode-Over/Under Shutdown in Memory	Flashing Code 7	Cycling Code 7
Test Mode-UPS in Memory	Flashing Code 8	Cycling Code 8
Swapped FP1/FP2 Lockout	Flashing Code 9	Cycling Code 9

Fig. 15 — Units with Complete C Controller, Single-Phase

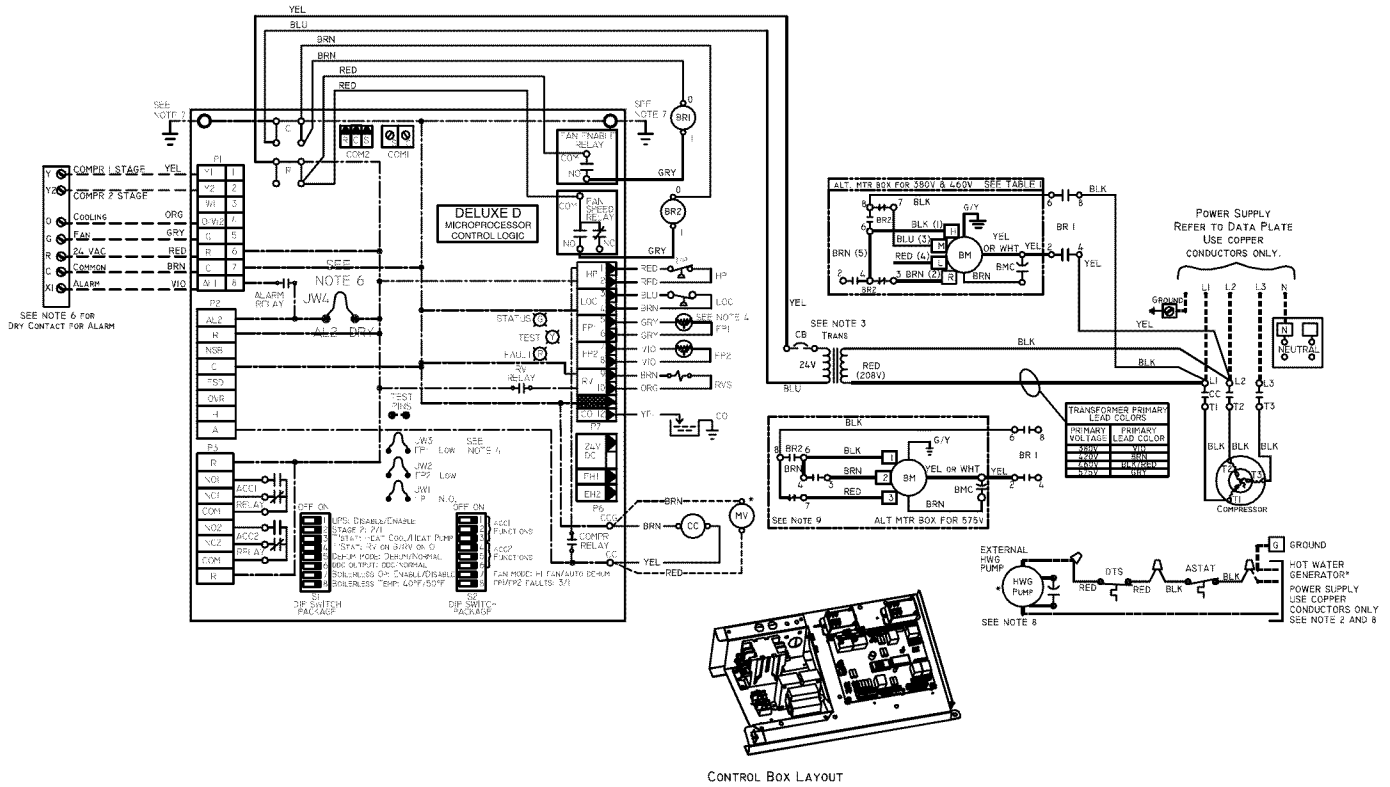

- AL** — Alarm Relay Contacts
- ASTAT** — Aquastat
- BM** — Blower Motor
- BMC** — Blower Motor Capacitor
- BR** — Blower Relay
- CB** — Circuit Breaker
- CC** — Compressor Contactor
- CO** — Condensate Overflow Sensor
- COMPR** — Compressor
- DTS** — Discharge Temp Switch
- FP1** — Water Coil Freeze Protection Sensor
- FP2** — Air Coil Freeze Protection Sensor
- HP** — High-Pressure Switch
- HWG** — Hot Water Generator
- JW** — Jumper Wire
- LOC** — Loss of Charge Pressure Switch
- MV** — Motorized Valve
- NEC** — National Electric Code

*Optional.

NOTES:

1. Compressor and blower motor thermally protected internally.
2. All wiring to the unit must comply with NEC and local codes.
3. Transformer is wired to 460 v (BLK/RED) lead for 460/60/3 units, 575 v (GRY) lead for 575/60/3. Transformer is energy limiting or may have circuit breaker.
4. FP1 thermistor provides freeze protection for water. When using anti-freeze solutions, cut JW3 jumper.
5. Check installation wiring information for specific thermostat hookup. Refer to thermostat installation instructions for wiring to the unit. Thermostat wiring must be "Class 1" and voltage rating equal to or greater than unit supply voltage.
6. 24-v alarm signal shown. For dry alarm contact, cut JW4 jumper and dry contact will be available between AL1 and AL2.
7. Transformer secondary ground via Deluxe D board standoffs and screws to control box. (Ground available from top two standoffs as shown.)
8. Aquastat is supplied with unit and must be wired in series with the hot leg to the pump. Aquastat is rated for voltage up to 277 v.
9. Blower motor is factory wired for high and low speeds. No other combination is available.
10. The 460-v units using an ECM (electronically commutated motor) fan motor, modulating HWR, and/or an internal secondary pump will require a neutral wire from the supply side in order to feed the accessory with 265-v.

TABLE 1	WIRE NUMBER				
	1	2	3	4	5
Blower Speeds					
Factory HI + MED	BM(H) to BR2(6)	BM(R) to BR2(3)	BM(M) to BR2(7)	Not Used	BR2(6) to BR2(4)
HI + LOW	BM(H) to BR2(6)	BM(R) to BR2(3)	Not Used	BM(L) to BR2(7)	BR2(6) to BR2(4)
MED + LOW	BM(H) to BR2(3)	BM(R) to BR2(3)	BM(M) to BR2(6)	BM(L) to BR2(7)	BR2(2) to BR2(4)

DELUXE D CONTROLLER FAULT CODES

OPERATION	STATUS LED (GREEN)	TEST LED (YELLOW)	FAULT LED (RED)	ALARM RELAY
Normal Mode	ON	OFF	Note 2	Open
Deluxe D is Non-Functional	OFF	OFF	OFF	Open
Test Mode	—	ON	Note 2	Cycle (Note 3)
Night Setback	Flashing Code 2	—	Note 2	—
Emergency Shut Down	Flashing Code 3	—	Note 2	—
Invalid Thermostat Inputs	Flashing Code 4	—	Note 2	—
No Fault in Memory	ON	OFF	Flashing Code 1	Open
HP Fault/(Lockout) Note 1	Slow Flash/ (Fast Flash)	OFF	Flashing Code 2	Open/(Closed)
LP Fault/(Lockout) Note 1	Slow Flash/ (Fast Flash)	OFF	Flashing Code 3	Open/(Closed)
FP1 Fault/(Lockout) Note 1	Slow Flash/ (Fast Flash)	OFF	Flashing Code 4	Open/(Closed)
FP2 Fault/(Lockout) Note 1	Slow Flash/ (Fast Flash)	OFF	Flashing Code 5	Open/(Closed)
CC Fault/(Lockout) Note 1	Slow Flash/ (Fast Flash)	OFF	Flashing Code 6	Open/(Closed)
Over-Under Voltage	Slow Flash	OFF	Flashing Code 7	Open (Note 4)
Normal Mode with UPS	ON	OFF	Flashing Code 8	Cycle (Note 5)
Swapped FP1/FP2 Lockout	Fast Flash	OFF	Flashing Code 9	Closed

NOTES:

1. Status LED (GREEN) Slow Flash - Controller In - Fault Retry Mode. Fast Flash - Controller in Lock-out Mode. Slow Flash = 1 Flash per every 2 seconds. Fast Flash = 2 Flashes per every 1 second.
2. Fault LED (RED) flashes a code representing last fault in memory. If no fault in memory code 1 is flashed.
3. Cycles appropriate code, by cycling alarm relay in the same sequence as fault LED.
4. Alarm relay closes after 15 minutes.
5. Alarm relay cycles. Closed for 5 seconds and open for 25 seconds.

Fig. 16 — Units with Deluxe D Controller, Three-Phase (460/575 V)

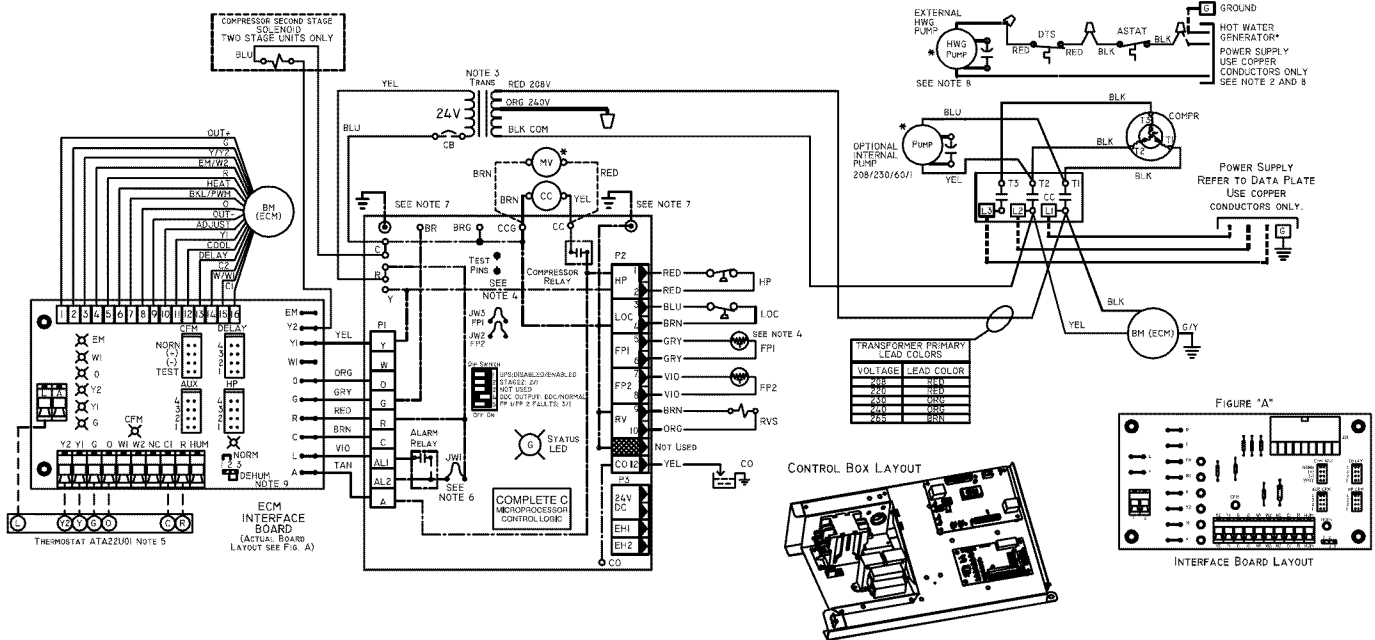

- AL** — Alarm Relay Contacts
ASTAT — Aquastat
BM — Blower Motor
BR — Blower Relay
CB — Circuit Breaker
CC — Compressor Contactor
CO — Condensate Overflow Sensor
COMPR — Compressor
DTS — Discharge Temp Switch
ECM — Electronically Commutated Motor
FP1 — Water Coil Freeze Protection Sensor
FP2 — Air Coil Freeze Protection Sensor
HP — High-Pressure Switch
HWG — Hot Water Generator
JW — Jumper Wire
LOC — Loss of Charge Pressure Switch
LWT — Leaving Water Temperature
MV — Motorized Valve
NEC — National Electric Code
P1 — Field Wiring Terminal Block

- RVS** — Reversing Valve Solenoid
TRANS — Transformer
UPS — Unit Performance Sentinel
 Factory Low Voltage Wiring
 Factory Line Voltage Wiring
 Field Low Voltage Wiring
 Field Line Voltage Wiring
 Printed Circuit Trace
 Optional Wiring
- Relay/Contactor Coil
 Thermistor
 Condensate Pan
 Circuit Breaker
 Ground

- Solenoid Coil
 Relay Contacts - N.C.
 Relay Contacts - N.O.
 Capacitor
 Temperature Switch
 Low Pressure Switch
 High Pressure Switch
 Wire Nut
 Splice Cap
 LED

*Optional.

- NOTES:**
- Compressor and blower motor thermally protected internally.
 - All wiring to the unit must comply with NEC and local codes.
 - 208/230 v transformer will be connected for 208 v operation. For 230 v operation, disconnect RED lead at L1 and attach ORANGE lead to L1. Insulate open end of RED lead. Transformer is energy limiting or may have circuit breaker.
 - FP1 thermistor provides freeze protection for water. When using antifreeze solutions, cut JW3 jumper.
 - Check installation wiring information for specific thermostat hookup. Refer to thermostat installation instructions for wiring to the unit. Thermostat wiring must be "Class 1" and voltage rating equal to or greater than unit supply voltage.
 - 24-v alarm signal shown. For dry alarm contact, cut JW1 jumper and dry contact will be available between AL1 and AL2.
 - Transformer secondary ground via Complete C board standoffs and screws to control box. (Ground available from top two standoffs as shown.)
 - Aquastat is supplied with unit and must be wired in series with the hot leg to the pump. Aquastat is rated for voltage up to 277 v.

COMPLETE C CONTROLLER FAULT CODES

DESCRIPTION OF OPERATION	LED	ALARM RELAY
Normal Mode	ON	Open
Normal Mode with UPS Warning	ON	Cycle (Closed 5 Sec. Open 25 Sec.)
Complete C is Non-Functional	OFF	Open
Fault Retry	Slow Flash	Open
Lockout	Fast Flash	Closed
Over/Under Voltage Shutdown	Slow Flash	Open (Closed After 15 Min.)
Test Mode-No Fault in Memory	Flashing Code 1	Cycling Code 1
Test Mode-HP Fault in Memory	Flashing Code 2	Cycling Code 2
Test Mode-LP Fault in Memory	Flashing Code 3	Cycling Code 3
Test Mode-FP1 Fault in Memory	Flashing Code 4	Cycling Code 4
Test Mode-FP2 Fault in Memory	Flashing Code 5	Cycling Code 5
Test Mode-CO Fault in Memory	Flashing Code 6	Cycling Code 6
Test Mode-Over/Under Shutdown in Memory	Flashing Code 7	Cycling Code 7
Test Mode-UPS in Memory	Flashing Code 8	Cycling Code 8
Swapped FP1/FP2 Lockout	Flashing Code 9	Cycling Code 9

Fig. 17 — Units with Complete C ECM Blower, Three-Phase (208/230 V)

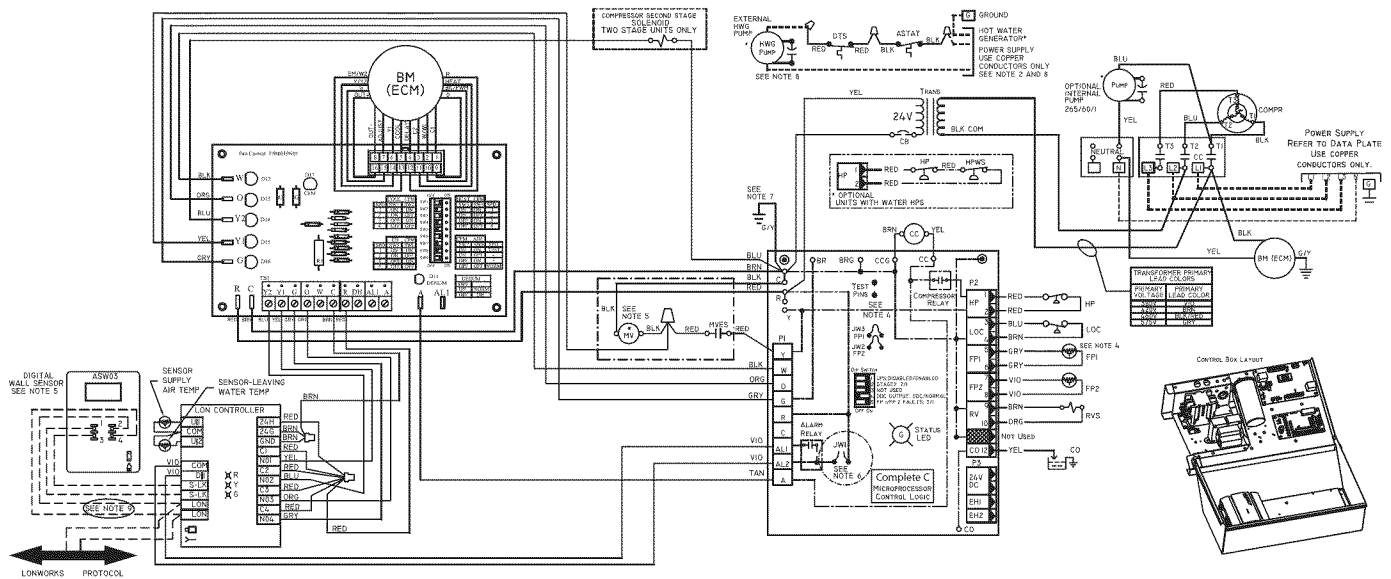

LEGEND

- AL** — Alarm Relay Contacts
- ASTAT** — Aquastat
- BM** — Blower Motor
- BMC** — Blower Motor Capacitor
- BR** — Blower Relay
- CB** — Circuit Breaker
- CC** — Compressor Contactor
- CO** — Sensor, Condensate Overflow
- DTS** — Discharge Temperature Switch
- ECM** — Electronically Commutated Motor
- FP1** — Sensor, Water Coil Freeze Protection
- FP2** — Sensor, Air Coil Freeze Protection
- HP** — High-Pressure Switch
- HPWS** — High-Pressure Water Switch
- HWG** — Hot Water Generator
- JW1** — Clippable Field Selection Jumper
- LOC** — Loss of Charge Pressure Switch
- LON** — Local Operating Network
- MV** — Motorized Valve
- MVES** — Motorized Valve End Switch

- NEC** — National Electrical Code
- P1** — Field Wiring Terminal Block
- RVS** — Reversing Valve Solenoid
- TRANS** — Transformer
- Field Line Voltage Wiring
- Field Low Voltage Wiring
- - - Printed Circuit Trace
- . . Optional Wiring
- Relay/Contactor Coil
- Condensate Pan
- ⚡ Solenoid Coil
- ⊕ Temperature Switch
- ⊕ Thermistor
- ⊕ Ground

- ⊕ Wire Nut
- ⊕ Relay Contacts - N.C.
- ⊕ Relay Contacts - N.O.
- ⊕ Low Pressure Switch
- ⊕ High Pressure Switch
- ⊕ Splice Cap
- ⊕ Circuit Breaker

NOTES:

1. Compressor and blower motor thermally protected internally.
2. All wiring to the unit must comply with NEC and local codes.
3. Transformer is wired to 460 v (BLK/RED) lead for 460/3/60 units. Transformer is energy limiting or may have circuit breaker.
4. FP1 thermistor provides freeze protection for water. When using antifreeze solutions, cut JW3 jumper.
5. Typical thermostat wiring shown. Refer to thermostat installation instructions for wiring to the unit. Thermostat wiring must be Class 1 and voltage rating equal to or greater than unit supply voltage.
6. Factory cut JW1 jumper. Dry contact will be available between AL1 and AL2.
7. Transformer secondary ground via Complete C board standoffs and screws to control box. (Ground available from top two standoffs as shown.)

8. Aquastat is supplied with unit and must be wired in series with the hot leg to the pump. Aquastat is rated for voltages up to 277-v.
9. Optional LON wires. Only connect if LON connection is desired at the wall sensor.
10. Fan motors are factory wired for medium speed. For high or low speed, remove BLU wire from fan motor speed tap "M" and connect to "H" for high speed or "L" for low speed.
11. For low speed, remove BLK wire from BR "6" and replace with RED. Connect BLK and BRN wires together.
12. For blower motors with leads. For medium or low speed, disconnect BLK wire from BR "6". Connect BLK and ORG/PUR wire together. Connect RED for low or BLU for medium to BR "6".
13. The 460-v units using an ECM (electronically commutated motor) fan motor, modulating HWR (hot water reheat), and/or an internal secondary pump will require a neutral wire from the supply side in order to feed the accessory with 265-v.

Fig 18 — Units with ECM, Complete C and LON Controller (460 V)

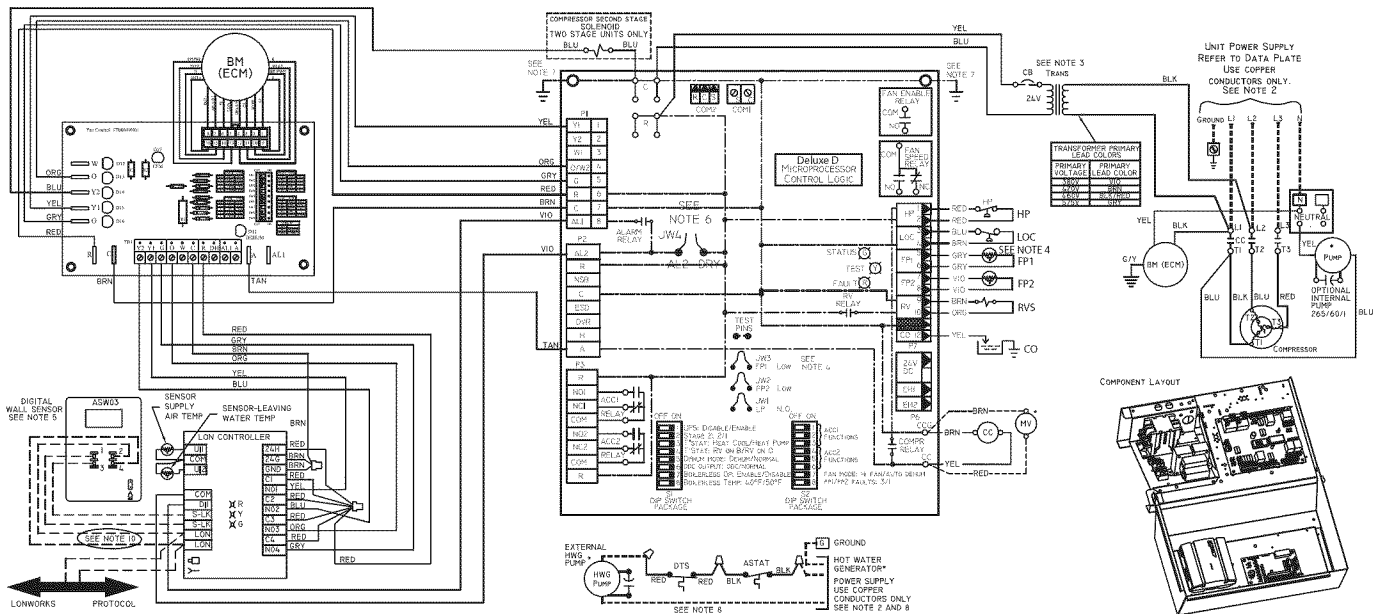

LEGEND

- AL** — Alarm Relay Contacts
 - ASTAT** — Aquastat
 - BM** — Blower Motor
 - BMC** — Blower Motor Capacitor
 - BR** — Blower Relay
 - CB** — Circuit Breaker
 - CC** — Compressor Contactor
 - CO** — Sensor, Condensate Overflow
 - DTS** — Discharge Temperature Switch
 - ECM** — Electronically Commutated Motor
 - FP1** — Sensor, Water Coil Freeze Protection
 - FP2** — Sensor, Air Coil Freeze Protection
 - HP** — High-Pressure Switch
 - HPWS** — High-Pressure Water Switch
 - HWG** — Hot Water Generator
 - JW1** — Clippable Field Selection Jumper
 - LOC** — Loss of Charge Pressure Switch
 - LON** — Local Operating Network
 - MV** — Motorized Valve
 - NEC** — National Electrical Code
- *Optional Wiring.

- P1** — Field Wiring Terminal Block
- RVS** — Reversing Valve Solenoid
- TRANS** — Transformer
- Field Line Voltage Wiring
- - - Field Low Voltage Wiring
- . - Printed Circuit Trace
- . . Optional Wiring
- Relay/Contactor Coil
- Condensate Pan
- ⊞ Solenoid Coil
- ⊞ Temperature Switch
- ⊞ Thermistor
- ⊞ Ground

- Wire Nut
- ⊞ Relay Contacts - N.C.
- ⊞ Relay Contacts - N.O.
- ⊞ Low Pressure Switch
- ⊞ High Pressure Switch
- ⊞ Splice Cap
- ⊞ Circuit Breaker

NOTES:

1. Compressor and blower motor thermally protected internally.
2. All wiring to the unit must comply with NEC and local codes.
3. Transformer is wired to 460 v (BLK/RED) lead for 460/3/60 units. Transformer is energy limiting or may have circuit breaker.
4. FP1 thermistor provides freeze protection for water. When using antifreeze solutions, cut JW3 jumper.
5. Typical thermostat wiring shown. Refer to thermostat installation instructions for wiring to the unit. Thermostat wiring must be Class 1 and voltage rating equal to or greater than unit supply voltage.
6. Factory cut JW1 jumper. Dry contact will be available between AL1 and AL2.
7. Transformer secondary ground via Deluxe D board standoffs and screws to control box. (Ground available from top two standoffs as shown.)

8. Aquastat is supplied with unit and must be wired in series with the hot leg to the pump. Aquastat is rated for voltages up to 277-v.
9. Blower motor is factory wired for medium and high speeds. For any other combination of speeds, at the motor attach the BLK wire to the higher of the two desired speed taps and the BLU wire to the lower of the two desired speed taps.
10. Optional LON wires. Only connect if LON connection is desired at the wall sensor.
11. Blower motor is factory wired for high and low speeds. No other combination is available.
12. The 460-v units using an ECM (electronically commutated motor) fan motor, modulating HWR (hot water reheat), and/or an internal secondary pump will require a neutral wire from the supply side in order to feed the accessory with 265-v.

Fig 19 — Units with ECM, Deluxe D and LON Controller (460 V)

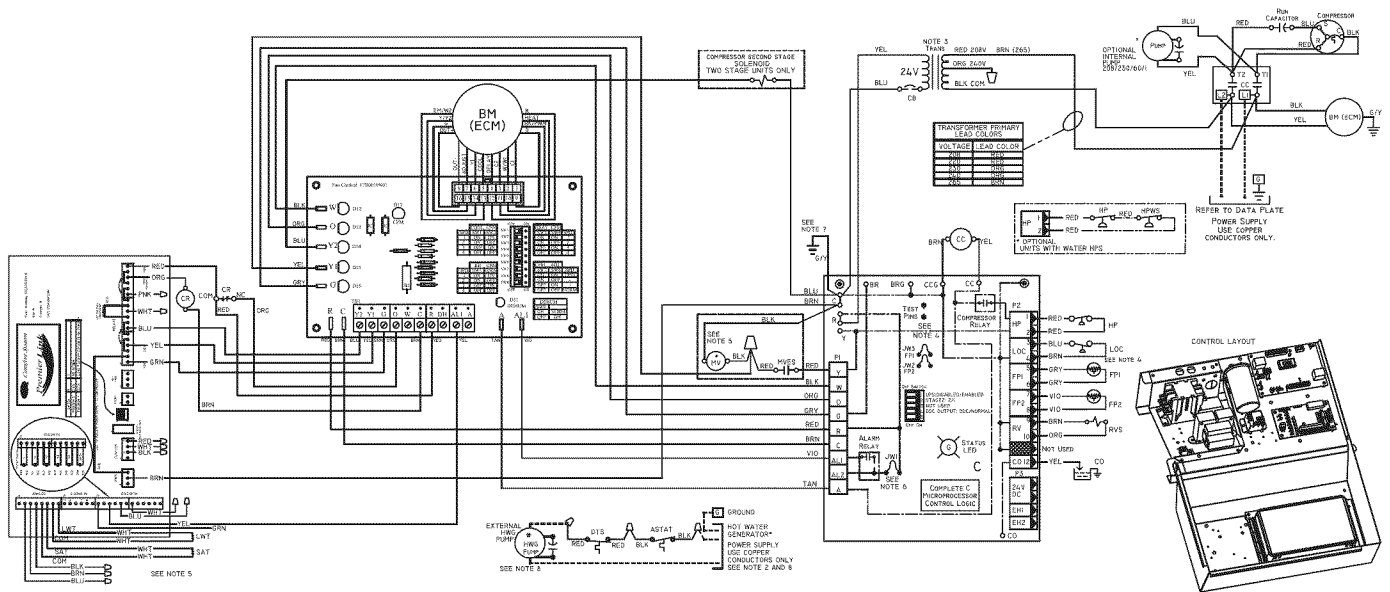

LEGEND

- AL** — Alarm Relay Contacts
- ASTAT** — Aquastat
- BM** — Blower Motor
- BR** — Blower Relay
- CB** — Circuit Breaker
- CC** — Compressor Contactor
- CO** — Sensor, Condensate Overflow
- CR** — Cooling Relay
- DTS** — Discharge Temp Switch
- ECM** — Electronically Commuted Motor
- FP1** — Sensor, Water Coil Freeze Protection
- FP2** — Sensor, Air Coil Freeze Protection
- HP** — High Pressure Switch
- HPWS** — High Pressure Water Switch
- HWG** — Hot Water Generator
- JW** — Jumper Wire
- LOC** — Loss of Charge Pressure Switch
- LWT** — Leaving Water Temperature
- MV** — Motorized Valve
- MVES** — Motorized Valve End Switch
- P1** — Field Wiring Terminal Block

- RVS** — Reversing Valve Solenoid
- SAT** — Saturated Air Temperature
- TRANS** — Transformer
- UPS** — Unit Performance Sentinel
- Field Line Voltage Wiring
- Field Low Voltage Wiring
- Field Line Voltage Wiring
- Field Low Voltage Wiring
- Printed Circuit Trace
- Optional Wiring
- Relay/Contactor Coil
- Condensate Pan
- Solenoid Coil
- Temperature Switch

- Thermistor
- Ground
- Wire Nut
- Relay Contacts - N.C.
- Relay Contacts - N.O.
- Low Pressure Switch
- High Pressure Switch
- Splice Cap
- Circuit Breaker
- Capacitor
- LED

*Optional Wiring.

NOTES:

1. Compressor and blower motor thermally protected internally.
2. All wiring to the unit must comply with NEC and local codes.
3. 208-240 60 Hz units are wired for 208v operation. Transformer is energy limiting or may have circuit breaker.
4. FP1 thermistor provides low temperature protection for water. When using antifreeze solutions, cut JW3 jumper.
5. Refer to multiple protocol controller (MPC), LON, or TSTAT Installation, Application, and Operation Manual for control wiring to the wire from PremierLink controller to "Y" Complete C when motorized valve is not used. Thermostat wiring must be "Class 1" and voltage rating equal to or greater than unit supply voltage.
6. 24v alarm signal shown. For dry contact, cut JW1 jumper and dry contact will be available between AL1 and AL2.
7. Transformer secondary ground via green wire with yellow stripe from "C" terminal to control box.
8. Aquastat is supplied with unit and must be wired in series with the hot leg to the pump. Aquastat is rated for voltages up to 277v.

COMPLETE C CONTROLLER FAULT CODES

DESCRIPTION OF OPERATION	LED	ALARM RELAY
Normal Mode	ON	Open
Normal Mode with UPS Warning	ON	Cycle (Closed 5 Sec. Open 25 Sec.)
Complete C is Non-Functional	OFF	Open
Fault Retry	Slow Flash	Open
Lockout	Fast Flash	Closed
Over/Under Voltage Shutdown	Slow Flash	Open (Closed After 15 Min.)
Test Mode-No Fault in Memory	Flashing Code 1	Cycling Code 1
Test Mode-HP Fault in Memory	Flashing Code 2	Cycling Code 2
Test Mode-LP Fault in Memory	Flashing Code 3	Cycling Code 3
Test Mode-FP1 Fault in Memory	Flashing Code 4	Cycling Code 4
Test Mode-FP2 Fault in Memory	Flashing Code 5	Cycling Code 5
Test Mode-CO Fault in Memory	Flashing Code 6	Cycling Code 6
Test Mode-Over/Under Shutdown in Memory	Flashing Code 7	Cycling Code 7
Test Mode-UPS in Memory	Flashing Code 8	Cycling Code 8
Swapped FP1/FP2 Lockout	Flashing Code 9	Cycling Code 9

Fig. 20 — Units with Complete C and Premierlink™ Controller, Single-Phase (208/230 V)

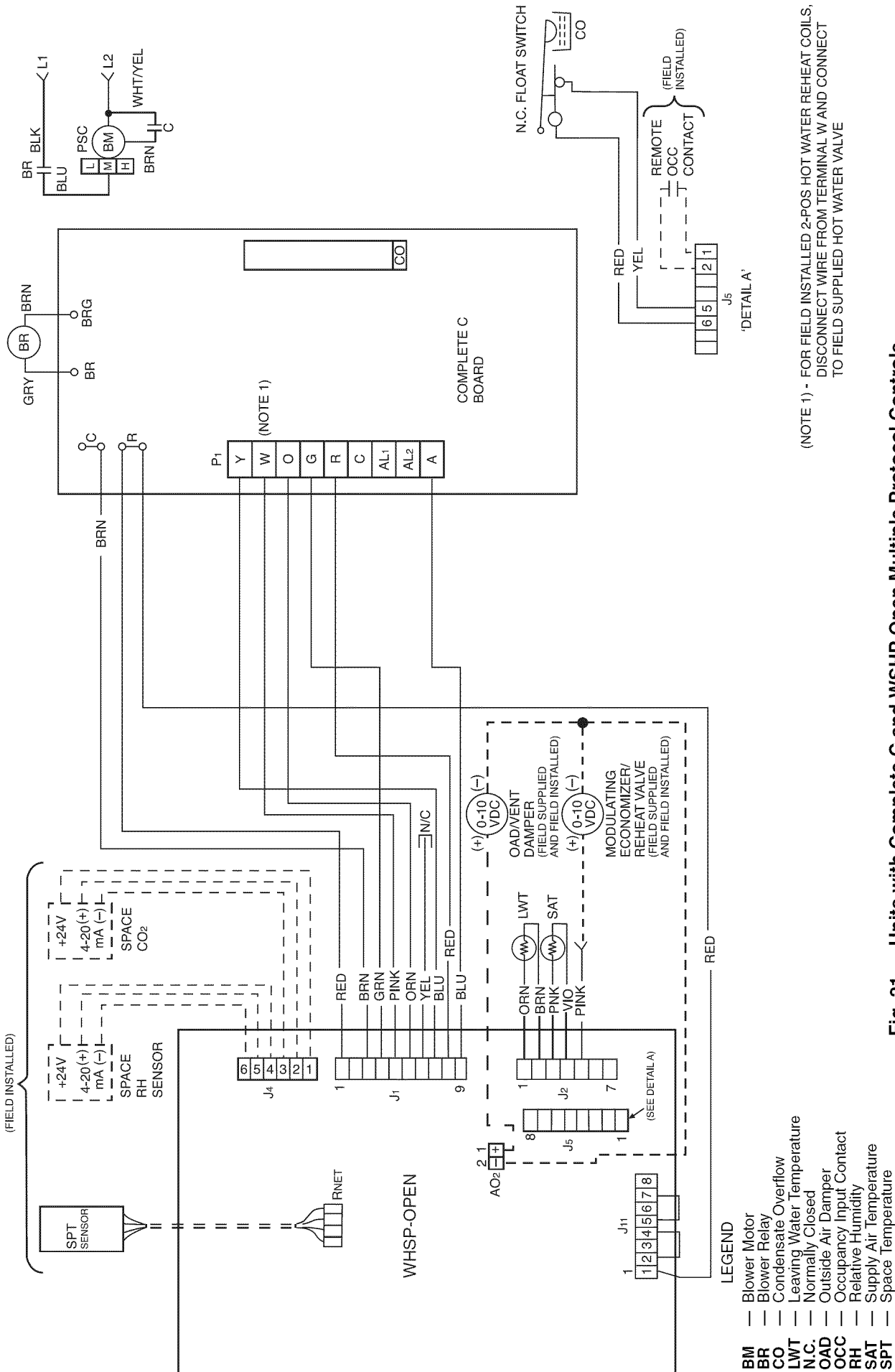

Fig. 21 — Units with Complete C and WSHP Open Multiple Protocol Controls

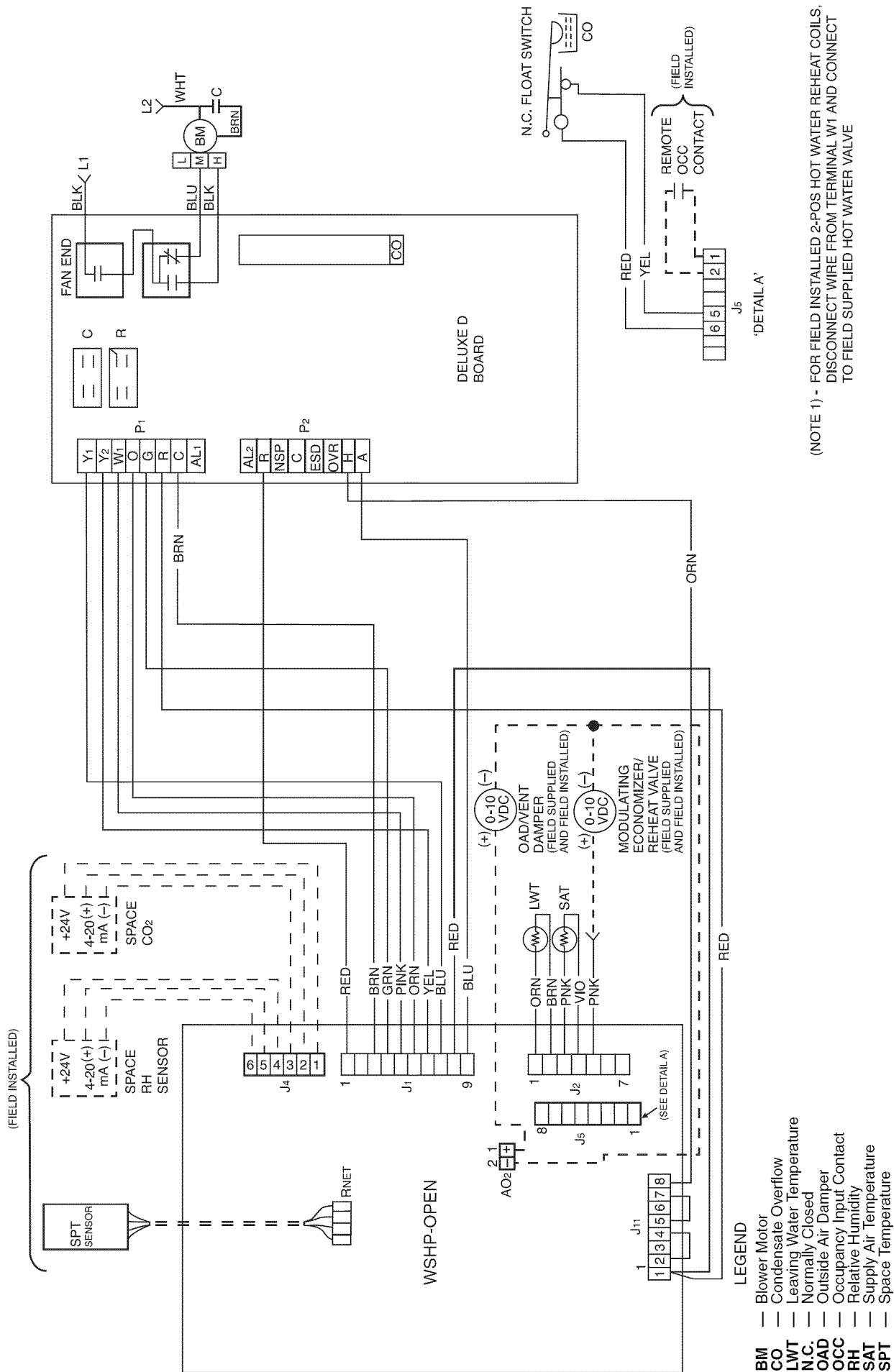

Fig. 22 — Units with Deluxe D and WSHP Open Multiple Protocol Controls

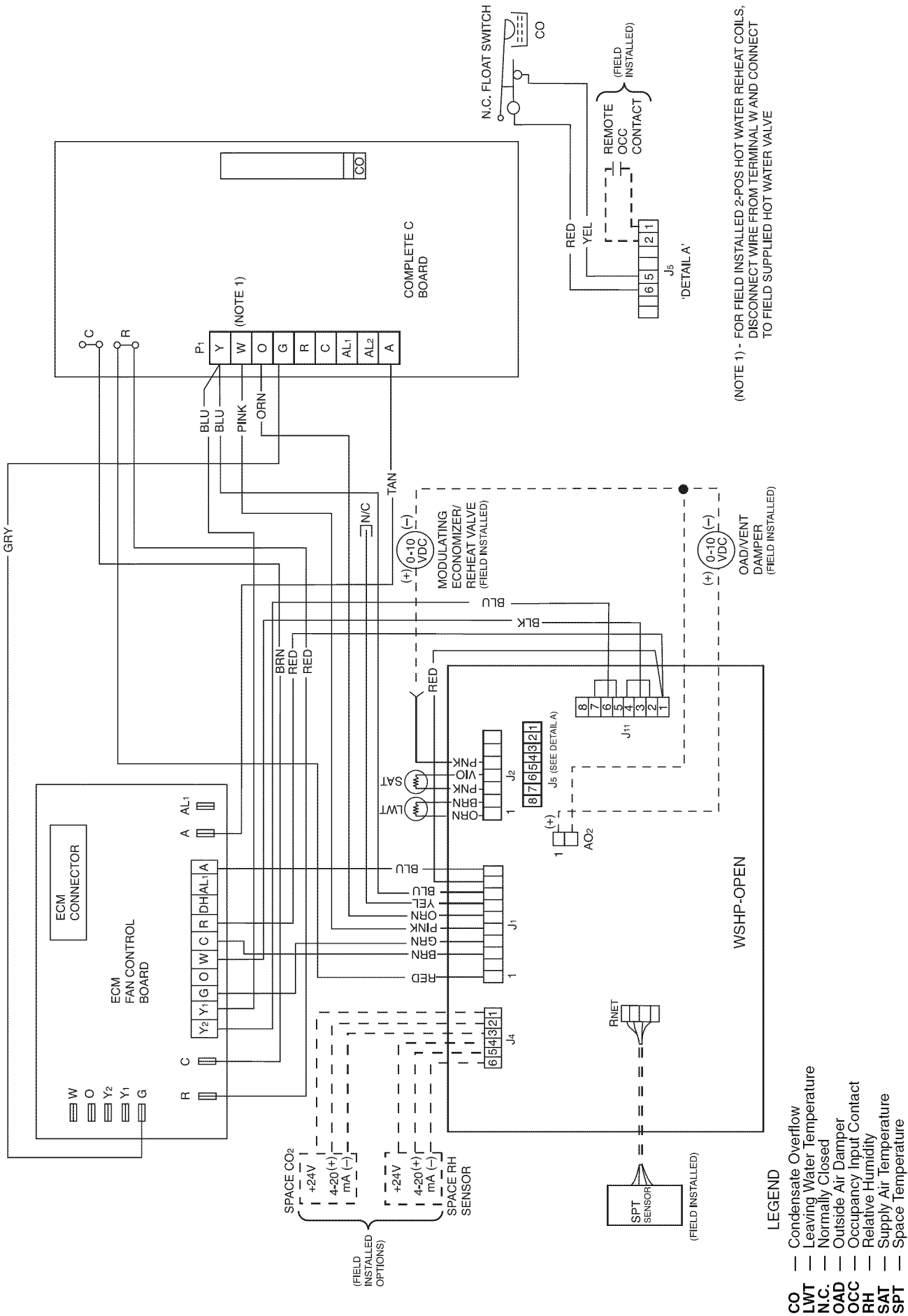

Fig. 23 — Units with Complete C, ECM and WSHP Open Multiple Protocol Controls

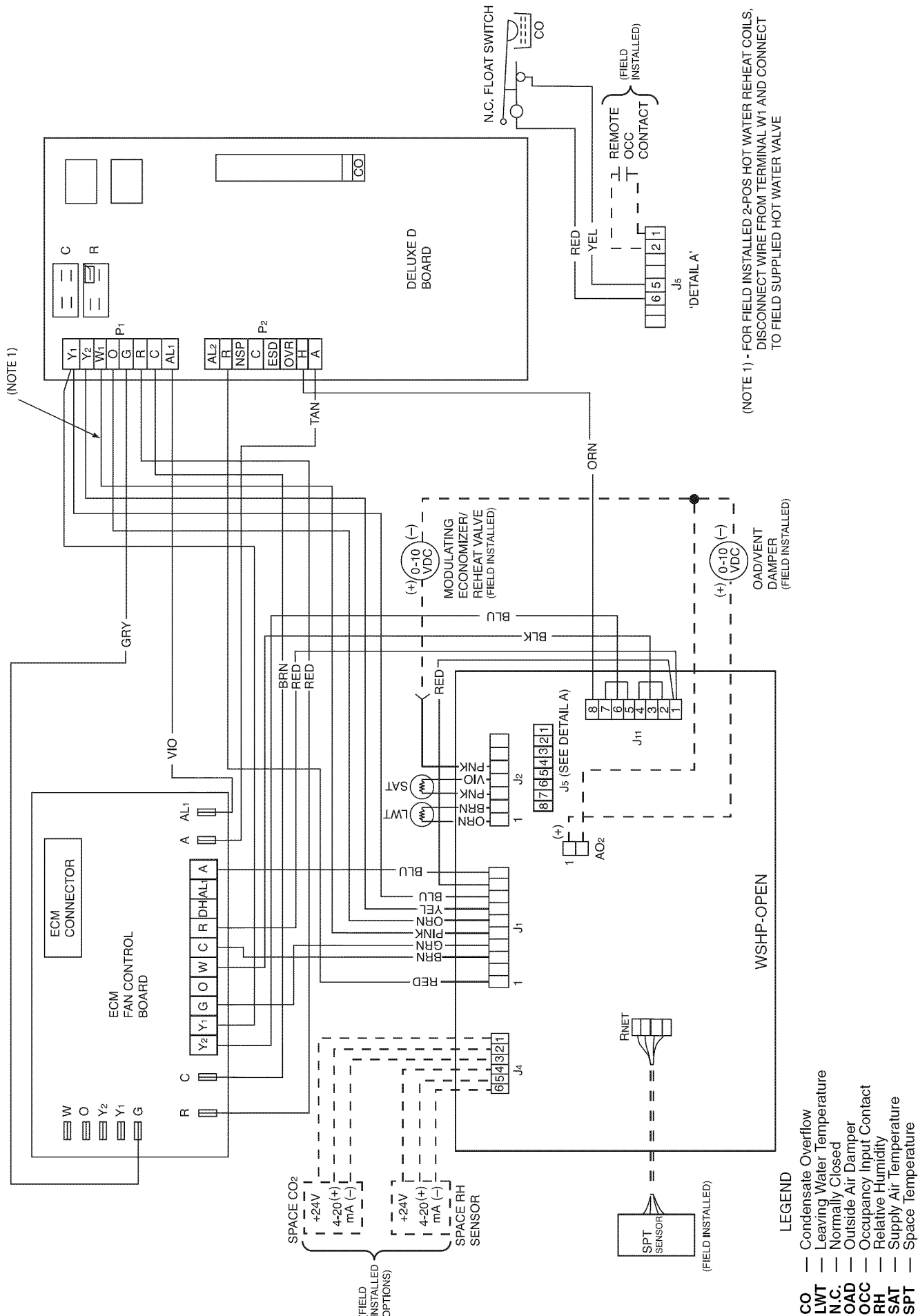

Fig. 24 — Units with Delux D, ECM and WSH-Open Multiple Protocol Controls



LEGEND
 AI Analog Input
 AO Analog Output
 BI Binary Input
 BO Binary Output
 SPT Space Temperature
 Field Wiring

NOTES:
 1. Mount the water source heat pump controller in the equipment controls enclosure with at least two #6 x 1 in. self-tapping screws. Allow adequate clearance for wiring.
 2. Verify sensor power and wiring requirements prior to making any terminations. Sensors requiring a separate isolated 24 vac power source will not utilize WSHP terminals J4-1, or 4.

WSHP Open Inputs and Outputs Table

INPUT/OUTPUT TYPE	PART NUMBERS	TYPE OF I/O	CONNECTION PIN NUMBERS	CHANNEL DESIGNATION
Inputs				
Space Temperature Sensor	SPS, SPPL, SPP	Communicating	J13, 1 - 4	Local Access Port
Space Relative Humidity	33ZCSENRRH-01	AI (4 - 20mA)	J4, 5 and 6	Analog Input 1
Indoor Air Quality	33ZCSENCO2	AI (4 - 20mA)	J4, 2 and 3	Analog Input 2
Condensate Switch	N/A	BI (Dry Contacts)	J1, 2	Binary Input 3
Stage 1 Compressor Status	N/A	BI (Dry Contacts)	J1, 10	Binary Input 5
Leaving Condenser Water Temperature	10K Type II	AI (10K Thermistor)	J2, 1 and 2	Analog Input 6
Supply Air Temperature	33ZCSENSAT	AI (10K Thermistor)	J2, 3 and 4	Analog Input 7
Outputs				
Modulating Valve (Auxiliary Heat/Water Economizer)	N/A	AO (0-10Vdc/2 - 10Vdc)	J2 4 and 5*	Analog Output 1
Outside Air Damper	N/A	AO (0-10Vdc/2 - 10Vdc)	J22 1 and 2*	Analog Output 2
Supply Fan On/Low Speed (3 Speed Only)	N/A	BO Relay (24VAC, 1A)	J1, 4*	Binary Output 1 (G)
Auxiliary Heat or 2-Position Water Loop Economizer	N/A	BO Relay (24VAC, 1A)	J1, 5*	Binary Output 2
Reversing Valve (B or O Operation)	N/A	BO Relay (24VAC, 1A)	J1, 6*	Binary Output 3 (RV)
Compressor 2nd Stage	N/A	BO Relay (24VAC, 1A)	J1, 7	Binary Output 4 (Y2)
Compressor 1st Stage	N/A	BO Relay (24VAC, 1A)	J1, 8	Binary Output 5 (Y1)
Dehumidification Relay	N/A	BO Relay (24VAC, 1A)	J11, 7 and 8 (NO)	Binary Output 6
Fan Speed Medium/Low (3 Speed Only)	N/A	BO Relay (24VAC, 1A)	J11, 5 and 6 (NO)*	Binary Output 7
Fan Speed High/Low (3 Speed Only)	N/A	BO Relay (24VAC, 1A)	J11, 2 and 3 (NO)*	Binary Output 8

*These inputs are configurable.

Fig. 25 — WSHP Open Control

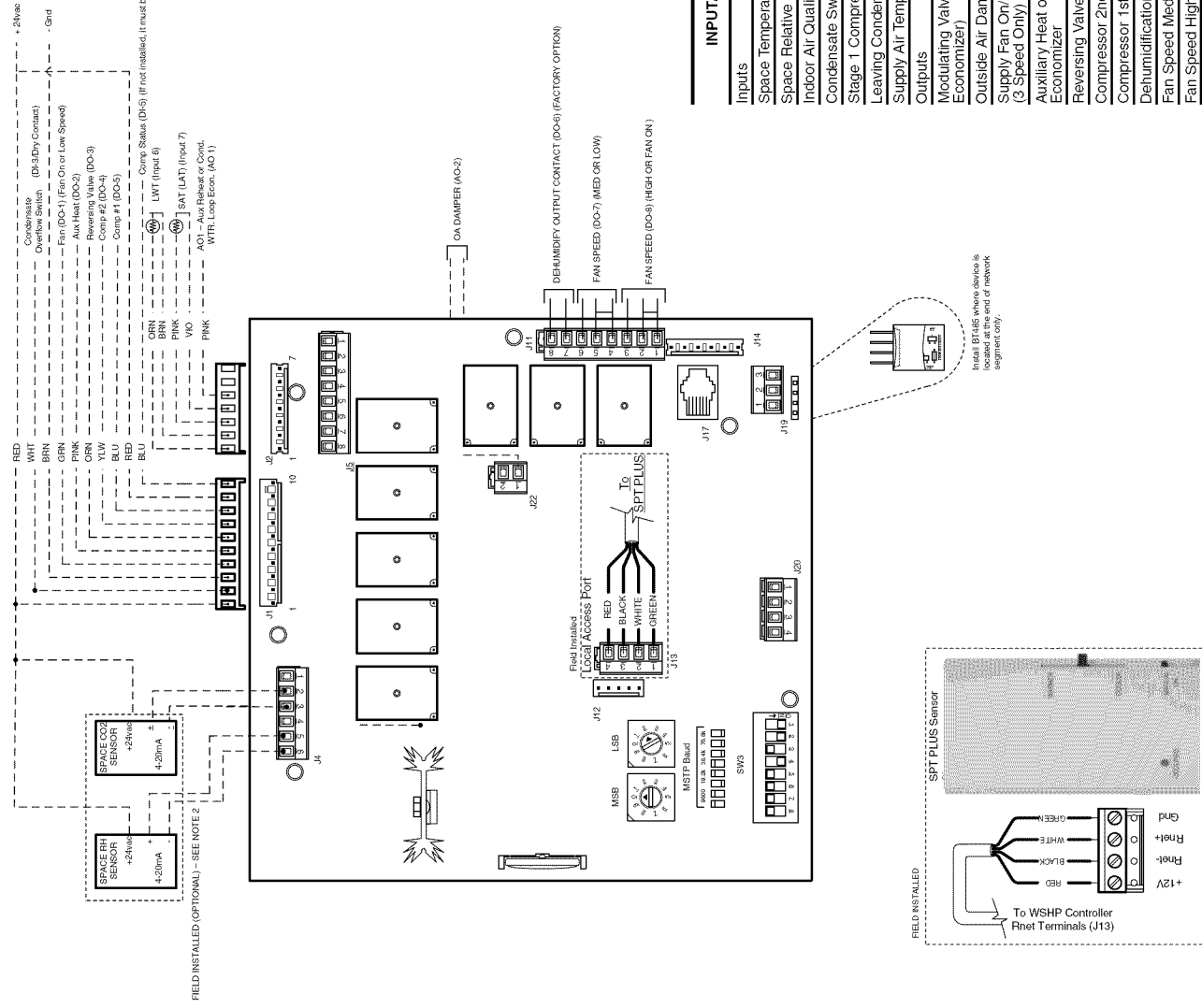

Table 4 — 50PSH, PSV, PSD Electrical Data — PSC Motor

50PS UNIT SIZE	RATED VOLTAGE V-Ph-Hz	VOLTAGE MIN/MAX	COMPRESSOR			FAN MOTOR FLA	TOTAL UNIT FLA	MIN CIRCUIT AMP	MAX FUSE/HACR	UNITS WITH PSC MOTOR AND HWR			
			RLA	LRA	Qty					REHEAT PUMP FLA	TOTAL UNIT FLA	MIN CIRCUIT AMP	MAX FUSE / HACR
006	208/230-1-60	197/254	3.1	17.7	1	0.4	3.5	4.3	15	0.43	3.9	4.7	15
009	208/230-1-60	197/254	3.9	21.0	1	0.4	4.3	5.3	15	0.43	4.8	5.7	15
012	208/230-1-60	197/254	5.0	25.0	1	0.4	5.7	7.0	15	0.43	6.1	7.4	15
018	208/230-1-60	197/254	9.0	48.0	1	1.0	10.0	12.3	20	0.43	10.4	12.7	20
	265-1-60	239/292	8.4	40.0	1	0.9	9.3	11.4	15	N/A	N/A	N/A	N/A
024	208/230-1-60	197/254	12.8	60.0	1	1.1	13.9	17.1	25	0.43	14.3	17.5	30
	208/230-3-60	197/254	8.0	55.0	1	1.1	9.1	11.1	15	0.43	9.5	11.5	15
	460-3-60	414/506	4.0	22.4	1	0.6	4.6	5.6	15	N/A	N/A	N/A	N/A
030	208/230-1-60	197/254	13.5	61.0	1	1.4	14.9	18.3	30	0.80	15.7	19.1	30
	265-1-60	239/292	10.9	58.0	1	1.6	12.5	15.2	25	0.70	13.2	15.9	25
	208/230-3-60	197/254	8.3	63.0	1	1.4	9.7	11.8	20	0.80	10.5	12.6	20
	460-3-60	414/506	4.5	27.0	1	0.9	5.4	6.5	15	0.70	6.1	7.2	15
036	208/230-1-60	197/254	14.7	72.5	1	2.1	16.8	20.5	35	0.80	17.6	21.3	35
	265-1-60	239/292	12.5	61.0	1	2.2	14.7	17.8	30	0.70	15.4	18.5	30
	208/230-3-60	197/254	10.4	63.0	1	2.1	12.5	15.1	25	0.80	13.3	15.9	25
	460-3-60	414/506	4.5	32.0	1	1.3	5.8	6.9	15	0.70	6.5	7.6	15
042	208/230-1-60	197/254	15.4	83.0	1	2.1	17.5	21.4	35	0.80	18.3	22.2	35
	208/230-3-60	197/254	11.5	77.0	1	2.1	13.6	16.5	25	0.80	14.4	17.3	25
	460-3-60	414/506	5.1	35.0	1	1.0	6.1	7.4	15	0.70	6.8	8.1	15
	575-3-60	518/633	4.3	31.0	1	0.8	5.1	6.2	15	N/A	N/A	N/A	N/A
048	208/230-1-60	197/254	20.5	109.0	1	3.0	23.5	28.6	45	0.80	24.3	29.4	45
	208/230-3-60	197/254	14.6	91.0	1	3.0	17.6	21.3	35	0.80	18.4	22.1	35
	460-3-60	414/506	7.1	46.0	1	1.7	8.8	10.6	15	0.70	9.5	11.3	15
	575-3-60	518/633	5.1	34.1	1	1.4	6.5	7.8	15	N/A	N/A	N/A	N/A
060	208/230-1-60	197/254	26.9	145.0	1	4.9	31.8	38.5	60	1.07	32.9	39.6	60
	208/230-3-60	197/254	17.6	123.0	1	4.9	22.5	26.9	40	1.07	23.6	28.0	45
	460-3-60	414/506	9.6	64.0	1	2.5	12.1	14.5	20	1.07	13.2	15.6	25
	575-3-60	518/633	6.1	40.0	1	1.9	8.0	9.5	15	N/A	N/A	N/A	N/A
070	208/230-1-60	197/254	30.1	158.0	1	5.8	35.9	43.4	70	1.07	37.0	44.5	70
	208/230-3-60	197/254	20.5	155.0	1	5.8	26.3	31.4	50	1.07	27.4	32.5	50
	460-3-60	414/506	9.6	75.0	1	2.6	12.2	14.6	20	1.07	13.3	15.7	25
	575-3-60	518/633	7.6	54.0	1	2.3	9.9	11.8	15	N/A	N/A	N/A	N/A

LEGEND

- FLA — Full Load Amps
- HACR — Heating, Air Conditioning and Refrigeration
- HWR — Hot Water Reheat
- LRA — Locked Rotor Amps
- RLA — Rated Load Amps

NOTE: Unit sizes 006-012 are not available on 50PSD units.

Table 5 — 50PSH, PSV, PSD Electrical Data — PSC High-Static Motor

50PS UNIT SIZE	RATED VOLTAGE V-Ph-Hz	VOLTAGE MIN/MAX	COMPRESSOR			FAN MOTOR FLA	TOTAL UNIT FLA	MIN CIRCUIT AMP	MAX FUSE/HACR	UNITS WITH HIGH-STATIC PSC MOTOR AND HWR			
			RLA	LRA	Qty					REHEAT PUMP FLA	TOTAL UNIT FLA	MIN CIRCUIT AMP	MAX FUSE / HACR
018	208/230-1-60	197/254	9.0	48.0	1	1.10	7.9	12.4	20	0.80	10.9	13.2	20
	265-1-60	239/292	8.4	40.0	1	0.90	7.1	11.4	15	0.70	10.0	12.1	20
024	208/230-1-60	197/254	12.8	60.0	1	1.40	14.2	17.4	30	0.80	15.0	18.2	30
	208/230-3-60	197/254	8.0	55.0	1	1.40	9.4	11.4	15	0.80	10.2	12.2	20
	460-3-60	414/506	4.0	22.4	1	0.90	4.9	5.9	15	0.70	5.6	6.6	15
030	208/230-1-60	197/254	13.5	61.0	1	1.80	15.3	18.7	30	0.80	16.1	19.5	30
	265-1-60	239/292	10.9	58.0	1	2.00	12.9	15.6	25	0.70	13.6	16.3	25
	208/230-3-60	197/254	8.3	63.0	1	1.80	10.1	12.2	20	0.80	10.9	13.0	20
	460-3-60	414/506	4.5	27.0	1	1.24	5.7	6.9	15	0.70	6.4	7.6	15
036	208/230-1-60	197/254	14.7	72.5	1	2.00	16.7	20.4	35	0.80	17.5	21.2	35
	265-1-60	239/292	12.5	61.0	1	1.66	14.2	17.3	25	0.70	14.9	18.0	30
	208/230-3-60	197/254	10.4	63.0	1	2.00	12.4	15.0	25	0.80	13.2	15.8	25
	460-3-60	414/506	4.5	32.0	1	1.00	5.5	6.6	15	0.70	6.2	7.3	15
042	208/230-1-60	197/254	15.4	83.0	1	3.00	18.4	22.3	35	0.80	19.2	23.1	35
	208/230-3-60	197/254	11.5	77.0	1	3.00	14.5	17.4	25	0.80	15.3	18.2	25
	460-3-60	414/506	5.1	35.0	1	1.70	6.8	8.1	15	0.70	7.5	8.8	15
	575-3-60	518/633	4.3	31.0	1	1.40	5.7	6.8	15	N/A	N/A	N/A	N/A
048	208/230-1-60	197/254	20.5	109.0	1	3.40	23.9	29.0	45	1.07	25.0	30.1	50
	208/230-3-60	197/254	14.6	91.0	1	3.40	18.0	21.7	35	1.07	19.1	22.7	35
	460-3-60	414/506	7.1	46.0	1	1.80	8.9	10.7	15	1.07	10.0	11.7	15
	575-3-60	518/633	5.1	34.1	1	1.40	6.5	7.8	15	N/A	N/A	N/A	N/A
060	208/230-1-60	197/254	26.9	145.0	1	5.80	32.7	39.4	60	1.07	33.8	40.5	60
	208/230-3-60	197/254	17.6	123.0	1	5.80	23.4	27.8	45	1.07	24.5	28.9	45
	460-3-60	414/506	9.6	64.0	1	2.60	12.2	14.6	20	1.07	13.3	15.7	25
	575-3-60	518/633	6.1	40.0	1	2.30	8.4	9.9	15	N/A	N/A	N/A	N/A

LEGEND

- FLA — Full Load Amps
- HACR — Heating, Air Conditioning and Refrigeration
- HWR — Hot Water Reheat
- LRA — Locked Rotor Amps
- RLA — Rated Load Amps

NOTE: Unit sizes 006-012 are not available with PSC high-static motors.

Table 6 — 50PSH, PSV, PSD Electrical Data, ECM Motor

50PS UNIT SIZE	RATED VOLTAGE V-Ph-Hz	VOLTAGE MIN/MAX	COMPRESSOR			FAN MOTOR FLA	TOTAL UNIT FLA	MIN CIRCUIT AMP	MAX FUSE/HACR	UNITS WITH ECM MOTOR AND HWR			
			RLA	LRA	Qty					REHEAT PUMP FLA	TOTAL UNIT FLA	MIN CIRCUIT AMP	MAX FUSE / HACR
018	208/230-1-60	197/254	9.0	48.0	1	4.3	13.3	15.6	20	0.8	14.1	16.4	25
	265-1-60	239/292	8.4	40.0	1	4.1	12.5	14.6	20	0.7	13.2	15.3	20
024	208/230-1-60	197/254	12.8	60.0	1	4.3	17.1	20.3	30	0.8	17.9	21.1	30
	208/230-3-60	197/254	8.0	55.0	1	4.3	12.3	14.3	20	0.8	13.1	15.1	20
	460-3-60	414/506	4.0	22.4	1	4.1	8.1	9.1	15	0.7	8.8	9.8	15
030	208/230-1-60	197/254	13.5	61.0	1	4.3	17.8	21.2	30	0.8	18.6	22.0	35
	265-1-60	239/292	10.9	58.0	1	4.1	15.0	17.7	25	0.7	15.7	18.4	25
	208/230-3-60	197/254	8.3	63.0	1	4.3	12.6	14.7	20	0.8	13.4	15.5	20
	460-3-60	414/506	4.5	27.0	1	4.1	8.6	9.7	15	0.7	9.3	10.4	15
036	208/230-1-60	197/254	14.7	72.5	1	4.3	19.0	22.7	35	0.8	19.8	23.5	35
	265-1-60	239/292	12.5	61.0	1	4.1	16.6	19.7	30	0.7	17.3	20.4	30
	208/230-3-60	197/254	10.4	63.0	1	4.3	14.7	17.3	25	0.8	15.5	18.1	25
	460-3-60	414/506	4.5	32.0	1	4.1	8.6	9.7	15	0.7	9.3	10.4	15
042	208/230-1-60	197/254	15.4	83.0	1	4.3	19.7	23.6	35	0.8	20.5	24.4	35
	208/230-3-60	197/254	11.5	77.0	1	4.3	15.8	18.7	30	0.8	16.6	19.5	30
	460-3-60	414/506	5.1	35.0	1	4.1	9.2	10.5	15	0.7	9.9	11.2	15
048	208/230-1-60	197/254	20.5	109.0	1	7.0	27.5	32.6	50	1.07	28.6	33.7	50
	208/230-3-60	197/254	14.6	91.0	1	7.0	21.6	25.3	35	1.07	22.7	26.3	40
	460-3-60	414/506	7.1	46.0	1	6.9	14.0	15.8	20	1.07	15.1	16.8	20
060	208/230-1-60	197/254	26.9	145.0	1	7.0	33.9	40.6	60	1.07	35.0	41.7	60
	208/230-3-60	197/254	17.6	123.0	1	7.0	24.6	29.0	45	1.07	25.7	30.1	45
	460-3-60	414/506	9.6	64.0	1	6.9	16.5	18.9	25	1.07	17.6	20.0	25
070	208/230-1-60	197/254	30.1	158.0	1	7.0	37.1	44.6	70	1.07	38.2	45.7	70
	208/230-3-60	197/254	20.5	155.0	1	7.0	27.5	32.6	50	1.07	28.6	33.7	50
	460-3-60	414/506	9.6	75.0	1	6.9	16.5	18.9	25	1.07	17.6	20.0	25

LEGEND

- FLA — Full Load Amps
- HACR — Heating, Air Conditioning and Refrigeration
- HWR — Hot Water Reheat
- LRA — Locked Rotor Amps
- RLA — Rated Load Amps

NOTES:

1. The 460-v units using an ECM (electronically commutated motor) fan motor, modulating HWR, and/or an internal secondary pump will require a neutral wire from the supply side in order to feed the accessory with 265-v.
2. Unit sizes 006-012 are not available with ECM motors.

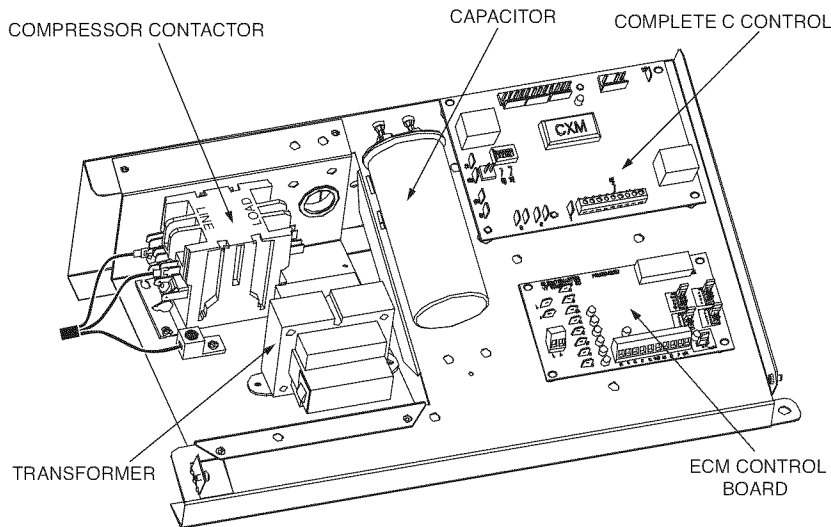

Fig. 26 — 50PSH,PSV,PSD Typical Single-Phase Line Voltage Power Connection

Step 9 — Wire Field Controls

THERMOSTAT CONNECTIONS — The thermostat should be wired directly to the ECM control board. See Fig. 27.

WATER FREEZE PROTECTION — The Aquazone™ control allows the field selection of source fluid freeze protection points through jumpers. The factory setting of jumper JW3 (FP1) is set for water at 30 F. In earth loop applications, jumper JW3 should be clipped to change the setting to 10 F when using antifreeze in colder earth loop applications. See Fig. 28.

NOTE: The extended range option should be selected with water temperatures below 60 F to prevent internal condensation.

AIR COIL FREEZE PROTECTION — The air coil freeze protection jumper JW2 (FP2) is factory set for 30 F and should not need adjusting.

ACCESSORY CONNECTIONS — Terminal A on the control is provided to control accessory devices such as water valves, electronic air cleaners, humidifiers, etc. This signal operates with the compressor terminal. See Fig. 29. Refer to the specific unit wiring schematic for details.

NOTE: The A terminal should *only* be used with 24-volt signals — not line voltage signals.

WATER SOLENOID VALVES — An external solenoid valve(s) should be used on ground water installations to shut off flow to the unit when the compressor is not operating. A slow closing valve may be required to help reduce water hammer. Figure 29 shows typical wiring for a 24-vac external solenoid valve. Figures 30 and 31 illustrate typical slow closing water control valve wiring for Taco 500 Series and Taco ESP Series valves. Slow closing valves take approximately 60 sec. to open (very little water will flow before 45 sec.). Once fully open, an end switch allows the compressor to be energized (only on valves with end switches). Only relay or triac based electronic thermostats should be used with slow closing valves. When wired as shown, the slow closing valve will operate properly with the following notations:

1. The valve will remain open during a unit lockout.
2. The valve will draw approximately 25 to 35 VA through the “Y” signal of the thermostat.

IMPORTANT: Connecting a water solenoid valve can overheat the anticipators of electromechanical thermostats. Only use relay based electronic thermostats.

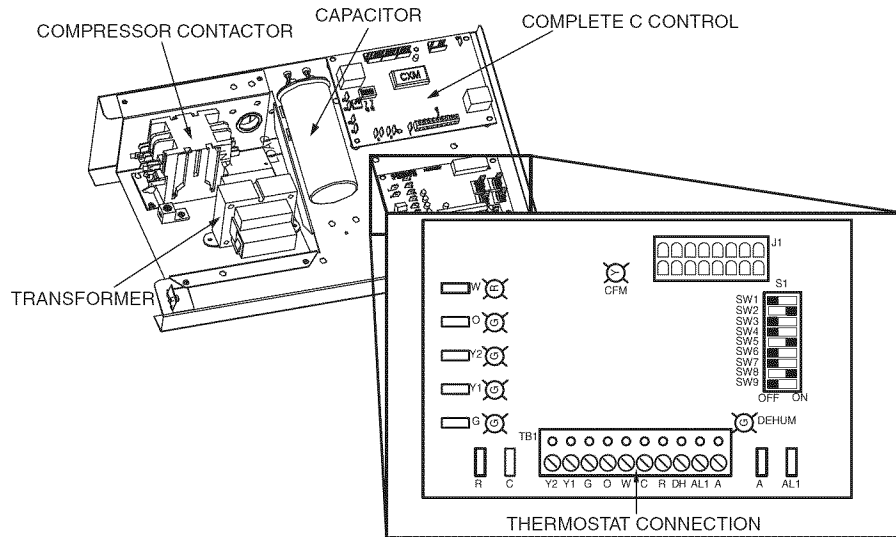
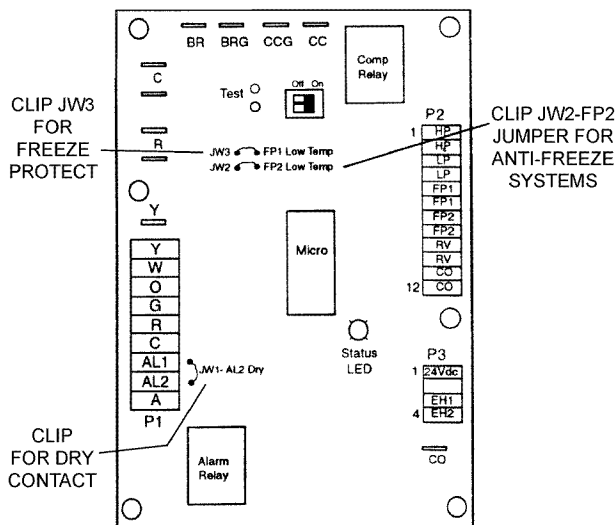

Fig. 27 — Low Voltage Field Wiring



AQUAZONE CONTROL (Complete C Shown)

Fig. 28 — Typical Aquazone™ Control Board Jumper Locations

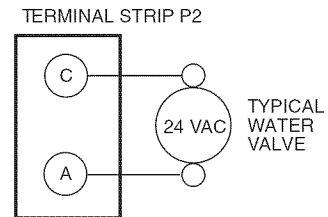

Fig. 29 — Typical Accessory Wiring

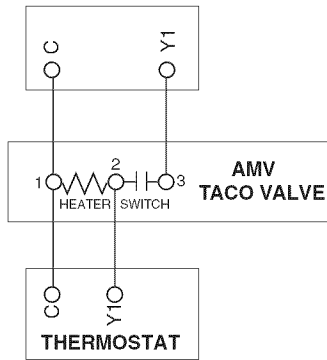

Fig. 30 — AMV Valve Wiring

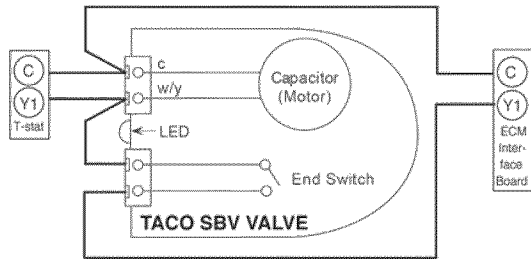

Fig. 31 — Taco SBV Valve Wiring

WSHP OPEN WIRING — The WSHP Open controller will be factory mounted to the unit control panel and wired to the Complete C or Deluxe D control board, however, the system wiring will need to be completed utilizing WSHP Open controller wiring diagrams and the Third Party Integration (TPI) Guide. Factory installation includes harness, LWT (leaving water temperature), supply air, and condensate sensor.

⚠ WARNING

Disconnect all power to the unit before performing maintenance or service. Unit may automatically start if power is not disconnected. Failure to follow this warning could cause personal injury, death, and/or equipment damage.

Wiring Sensors to Inputs — Sensors can be wired to the WSHP Open controller’s inputs. See Table 7.

All field control wiring that connects to the WSHP Open controller must be routed through the raceway built into the corner post. The raceway provides the UL required clearance between high and low-voltage wiring.

1. Pass control wires through hole provided in corner post.
2. Feed the wires through the raceway to the WSHP Open controller.
3. Connect the wires to the removable Phoenix connectors.
4. Reconnect the connectors to the board.

Field-Supplied Sensor Hardware — The WSHP Open controller is configurable with the following field-supplied sensors. See Table 7.

Table 7 — Field-Supplied Sensors for WSHP Open Controller

SENSOR	NOTES
Space Temperature Sensor (SPT)	Field Installed (Must be used with WSHP Open controller.)
Outdoor Air Temperature Sensor	Network Sensor
Indoor Air Quality Sensor (Separate Sensor)	Required only for demand control ventilation.
Space Relative Humidity Sensor	Separate Sensor

NOTE: BACview® Handheld or Virtual BACview can be used as the user interface.

For specific details about sensors, refer to the literature supplied with the sensor.

Wiring a SPT Sensor — A WSHP Open controller is connected to a wall-mounted space temperature (SPT) sensor to monitor room temperature using a Molex plug.

The WSHP Open system offers the following SPT sensors. See Table 8.

Table 8 — SPT Sensors

SENSOR	PART NUMBER	FEATURES
SPT Standard	SPS	<ul style="list-style-type: none"> • Local access port • No operator control
SPT Plus	SPPL	<ul style="list-style-type: none"> • Slide potentiometer to adjust set point • Manual on button to override schedule • LED to show occupied status • Local access port
SPT Pro	SPP	<ul style="list-style-type: none"> • LCD display • Manual on button to override schedule • Warmer and cooler buttons to adjust set point • Info button to cycle through zone and outside air temperatures, set points, and local override time • Local access port
SPT Pro Plus	SPPF	<ul style="list-style-type: none"> • LCD display • Manual on button to override schedule • Warmer and cooler buttons to adjust set point • Info button to cycle through zone and outside air temperatures, set points, and local override time • Local access port • Fan speed*

*The SPT Pro Plus fan speed adjustment has no effect in this application.

Wire SPT sensors to the WSHP Open controller’s Rnet port. An Rnetbus can consist of any of the following combinations of devices wired in a daisy-chain configuration:

- 1 SPT Plus, SPT Pro, or SPT Pro Plus sensor
- 1 to 4 SPT Standard sensors
- 1 to 4 SPT Standard sensors and 1 SPT Plus, SPT Pro, or SPT Pro Plus sensor
- Any of the above combinations, plus up to 2 BACview® Handheld but no more than 6 total devices

NOTE: If the Rnetbus has multiple SPT Standard sensors, each sensor must be given a unique address on the Rnetbus. See the Carrier Open Sensor Installation Guide.

Use the specified type of wire and cable for maximum signal integrity. See Table 9.

Table 9 — Rnet Wiring Specifications

RNET WIRING SPECIFICATIONS	
Description	4 conductor, unshielded, CMP, plenum rated cable
Conductor	18 AWG
Maximum Length	500 ft
Recommended Coloring	Jacket: white Wiring: black, white, green, red
UL Temperature	32 to 167 F
Voltage	300-vac, power limited
Listing	UL: NEC CL2P, or better

LEGEND

- AWG — American Wire Gauge
- CMP — Communications Plenum Cable
- NEC — National Electrical Code
- UL — Underwriters Laboratories

To wire the SPT sensor to the controller:

1. Partially cut , then bend and pull off the outer jacket of the Rnet cable(s), being careful not to nick the inner insulation.
2. Strip about 1/4 in. of the inner insulation from each wire. See Fig. 32.

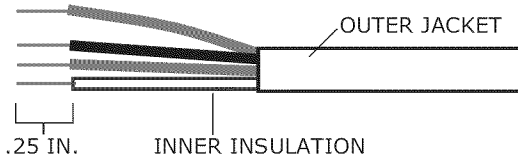

Fig. 32 — Rnet Cable Wire

3. Wire each terminal on the sensor to the same terminal on the controller. See Fig. 15-25. Table 10 shows the recommended Rnet wiring scheme.

Table 10 — Rnet Wiring

WIRE	TERMINAL
Red	+12-V
Black	.Rnet-
White	Rnet+
Green	Gnd

NOTE: The wire should be connected to the terminal shown.

Wiring a Supply Air Temperature (SAT) Sensor — The SAT sensor is required for reheat applications.

If the cable used to wire the SAT sensor to the controller will be less than 100 ft, an unshielded 22 AWG (American Wire Gage) cable should be used. If the cable will be greater than 100 ft, a shield 22 AWG cable should be used. The cable should have a maximum length of 500 ft.

To wire the SAT sensor to the controller:

1. Wire the sensor to the controller. See Fig. 15-25.
2. Verify that the Enable SAT jumper is on.
3. Verify that the Enable SAT and Remote jumper is in the left position.

Wiring an Indoor Air Quality (IAQ) Sensor — An IAQ sensor monitors CO₂ levels. The WSHP Open controller uses this information to adjust the outside-air dampers to provide proper ventilation. An IAQ sensor can be wall-mounted or mounted in a return air duct. (Duct installation requires an aspirator box assembly.)

The sensor has a range of 0 to 2000 ppm and a linear 4 to 20 mA output. This is converted to 1 to 5 vdc by a 250-ohm, 1/4 watt, 2% tolerance resistor connected across the zone controller's IAQ input terminals.

NOTE: Do not use a relative humidity sensor and CO₂ sensor on the same zone controller if both sensors are powered off the board. If sensors are externally powered, both sensors may be used on the same zone controller.

If the cable used to wire the IAQ sensor to the controller will be less than 100 ft, an unshielded 22 AWG (American Wire Gage) cable should be used. If the cable will be greater than 100 ft, a shield 22 AWG cable should be used. The cable should have a maximum length of 500 ft.

To wire the IAQ sensor to the controller:

1. Wire the sensor to the controller. See Fig. 15-25.
2. Install a field-supplied 250-ohm, 1/4 watt, 2% tolerance resistor across the controller's RH/IAQ and Gnd terminals.
3. Verify the the RH/IAQ jumper is set to 0 to 5 vdc.

Wiring a Relative Humidity (RH) Sensor — The RH sensor is used for zone humidity control (dehumidification) if the WSHP unit has a dehumidification device. If not, the sensor only monitors humidity.

NOTE: Do not use a relative humidity sensor and CO₂ sensor on the same zone controller if both sensors are powered off the board. If sensors are externally powered, both sensors may be used on the same zone controller.

If the cable used to wire the RH sensor to the controller will be less than 100 ft, an unshielded 22 AWG (American Wire

Gage) cable should be used. If the cable will be greater than 100 ft, a shield 22 AWG cable should be used. The cable should have a maximum length of 500 ft.

To wire the RH sensor to the controller:

1. Strip the outer jacket from the cable for at least 4 in.
2. Strip 1/4 in. of insulation from each wire.
3. Wire the sensor to the controller.

Step 10 — Operate ECM Interface Board —

The ECM fan is controlled by an interface board that converts thermostat inputs and field selectable cfm settings to signals used by the ECM (electronically commutated motor) controller. See Fig. 33.

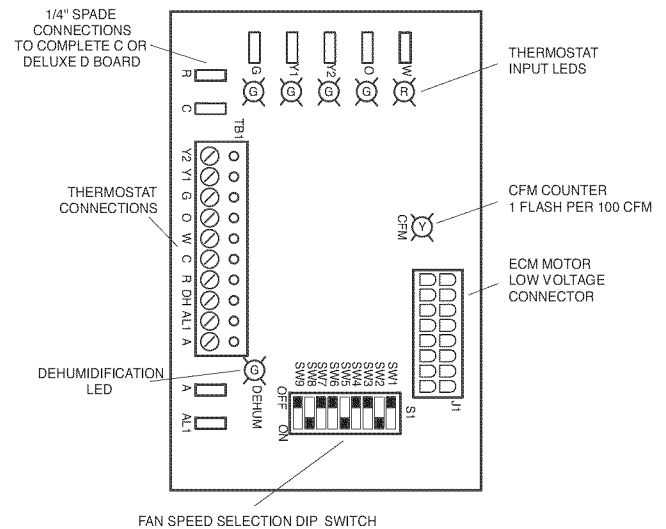

Fig. 33 — ECM Interface Board Physical Layout

NOTE: Power must be off to the unit for at least three seconds before the ECM will recognize a speed change. The motor will recognize a change in the CFM Adjust or Dehumidification mode settings while the unit is powered.

There are four different airflow settings from lowest airflow rate (speed tap 1) to the highest airflow rate (speed tap 4). Table 11 indicates settings for both versions of the ECM interface board, followed by detailed information for each setting.

CAUTION

When the disconnect switch is closed, high voltage is present in some areas of the electrical panel. Exercise caution when working with energized equipment. Failure to heed this safety precaution could lead to personal injury.

COOLING — The cooling setting determines the cooling (normal) cfm for all units with ECM motor. Cooling (normal) setting is used when the unit is not in Dehumidification mode. Tap 1 is the lowest cfm setting, while tap 4 is the highest cfm setting. To avoid air coil freeze-up, tap 1 may not be used if the Dehumidification mode is selected. See Table 11.

HEATING — The heating setting determines the heating cfm for 50PSH, PSV, PSD units. Tap 1 is the lowest cfm setting, while tap 4 is the highest cfm setting. See Table 11.

CFM ADJUST — The CFM Adjust setting allows four selections. The NORM setting is the factory default position. The + or - settings adjust the airflow by ±15%. The + or - settings are used to “fine tune” airflow adjustments. The TEST setting runs the ECM at 70% torque, which causes the motor to operate like a standard PSC motor, and disables the cfm counter. See Tables 11-13 for ECM and PSC blower motors performance data.

DEHUMIDIFICATION MODE — The dehumidification mode setting provides field selection of humidity control. When operating in the normal mode, the cooling airflow settings are determined by the cooling tap setting in Table 11. When dehumidification is enabled, there is a reduction in airflow in cooling to increase the moisture removal of the heat pump. The Dehumidification mode can be enabled in two ways:

1. Constant Dehumidification mode: When the Dehumidification mode is selected via DIP switch, the ECM will operate with a multiplier applied to the cooling CFM settings (approximately 20 to 25% lower airflow). Any time the unit is running in the Cooling mode, it will operate at the lower airflow to improve latent capacity. The “DEHUM” LED will be illuminated at all times. Heating airflow is not affected.

NOTE: Do not select Dehumidification mode if cooling setting is tap 1.

2. Automatic (humidistat-controlled) Dehumidification mode: When the Dehumidification mode is selected via DIP switch AND a humidistat is connected to terminal DH, the cooling airflow will only be reduced when the humidistat senses that additional dehumidification is required. The DH terminal is reverse logic. Therefore, a humidistat (not dehumidistat) is required. The “DEHUM” LED will be illuminated only when the humidistat is calling for Dehumidification mode. Heating airflow is not affected.

NOTE: Do not select Dehumidification mode if cooling setting is tap 1.

Table 11 — ECM Blower Motor Performance Data

50PS UNIT SIZE	MAX ESP (in. wg)	FAN MOTOR (hp)	TAP SETTING	COOLING MODE (cfm)			DEHUMIDIFICATION MODE (cfm)			HEATING MODE (cfm)		
				Stage 1	Stage 2	Fan	Stage 1	Stage 2	Fan	Stage 1	Stage 2	Fan
018	0.50	1/2	4	750	620	380	590	480	380	750	620	380
			3	700	570	350	550	450	350	700	570	350
			2	620	510	310	480	400	310	620	510	310
			1	530	430	270	—	—	—	530	430	270
024	0.50	1/2	4	950	780	470	740	610	470	1060	870	470
			3	850	700	420	660	540	420	950	780	420
			2	730	600	360	570	470	360	820	670	360
			1	610	500	300	—	—	—	690	570	300
030	0.50	1/2	4	1130	920	560	880	720	560	1230	1000	560
			3	1000	820	500	780	640	500	1100	900	500
			2	880	720	440	680	560	440	980	800	440
			1	750	620	380	—	—	—	850	700	380
036	0.50	1/2	4	1400	1150	700	1090	900	700	1400	1150	700
			3	1250	1020	630	980	800	630	1250	1020	630
			2	1080	890	540	840	690	540	1080	890	540
			1	900	740	450	—	—	—	900	740	450
042	0.50	1/2	4	1580	1290	790	1230	1010	790	1580	1290	790
			3	1400	1150	700	1100	900	700	1400	1150	700
			2	1230	1000	610	960	790	610	1230	1000	610
			1	1050	860	530	—	—	—	1050	860	530
048	0.75	1	4	1730	1420	870	1350	1110	870	1850	1520	870
			3	1550	1270	780	1210	990	780	1650	1350	780
			2	1330	1090	670	1040	850	670	1430	1180	670
			1	1120	920	560	—	—	—	1200	980	560
060	0.75	1	4	2050	1680	1030	1600	1310	1030	2280	1870	1030
			3	1825	1500	910	1420	1170	910	2050	1680	910
			2	1580	1300	790	1230	1010	790	1750	1430	790
			1	1320	1080	660	—	—	—	1470	1210	660
070	0.75	1	4	2230	1780	1100	1710	1400	1100	2230	1780	1100
			3	1950	1600	980	1520	1250	980	2100	1680	980
			2	1700	1400	850	1330	1090	850	1840	1470	850
			1	1450	1200	730	—	—	—	1520	1220	730

LEGEND

ESP — External Static Pressure

NOTES:

1. Factory setting is Tap Setting 2.
2. Airflow is controlled within 5% up to the Max ESP shown with wet coil.
3. Do not select Dehumidification mode if Tap Setting is on Setting 1.

4. All units are ARI/ISO (Air Conditioning & Refrigeration Institute/ International Organization for Standardization) 13256-1 rated Tap Setting 3.
5. Airflow in cfm with wet coil and clean air filter.
6. Units have an ECM (electronically commuted motor) fan motor as a standard feature. The small additional pressure drop of the reheat coil causes the ECM motor to slightly increase rpm to overcome the added pressure drop and maintain selected cfm up to maximum ESP (external static pressure).
7. Unit sizes 006-012 are not available with ECM motors.

Table 12 — PSC Blower Motor Performance Data

50PS UNIT SIZE	RATED AIRFLOW	MIN CFM	FAN SPEED	AIRFLOW (cfm) AT EXTERNAL STATIC PRESSURE (in. wg)																	
				0.00	0.05	0.10	0.15	0.20	0.25	0.30	0.35	0.40	0.45	0.50	0.60	0.70	0.80	0.90	1.00		
018	600	450	HI	704	708	711	702	693	692	690	683	675	658	640	598	515					
			MED	602	601	599	590	581	583	585	579	573	560	547	492						
			LO	531	529	527	522	517	512	506	501	495	479	462							
			HS HI	894	886	877	859	841	827	812	786	760	744	728	659						
			HS MED	765	760	755	747	738	725	711	690	668	654	640	602						
			HS LO	683	672	661	649	636	616	596	584	571	560	549							
024	850	600	HI	965	960	954	943	931	923	914	898	882	862	842	794	725	635				
			MED	841	833	825	817	809	800	790	777	763	747	731	686	623					
			LO	723	715	707	703	698	689	680	668	656	642	627							
			HS HI	1271	1250	1229	1207	1185	1164	1143	1118	1093	1061	1029	953	875	753				
			HS MED	1048	1037	1025	1016	1007	994	981	962	943	915	886	822	731	626				
			HS LO	890	887	884	879	874	865	855	842	829	809	789	726	660					
030	950	750	HI	1271	1250	1229	1207	1185	1164	1143	1118	1093	1061	1029	953	875	753				
			MED	1048	1037	1025	1016	1007	994	981	962	943	915	886	822						
			LO	890	887	884	879	874	865	855	842	829	809	789	726						
			HS HI	1439	1411	1383	1355	1327	1297	1266	1232	1198	1160	1122	1041	943	830				
			HS MED	1186	1174	1162	1151	1140	1126	1112	1089	1065	1039	1013	946	870	762				
			HS LO	1039	1038	1036	1028	1020	1009	997	983	968	946	923	866	798					
036	1250	900	HI	1411	1407	1402	1390	1378	1370	1361	1326	1290	1248	1205	1083	942					
			MED	1171	1164	1156	1145	1133	1113	1092	1064	1035	997	958							
			LO	983	967	950	943	936	936												
			HS HI	1648	1626	1617	1597	1576	1557	1537	1493	1448	1397	1345	1207	1051	957				
			HS MED	1344	1335	1325	1312	1299	1276	1253	1220	1186	1143	1099	1007	903					
			HS LO	1141	1128	1115	1106	1097	1077	1057	1031	1005	966	926							
042	1400	1050	HI	1634	1626	1618	1606	1594	1583	1571	1539	1507	1464	1420	1265	1078					
			MED	1332	1323	1314	1298	1282	1263	1243	1206	1169	1115	1060							
			LO	1130	1109	1088	1086	1084	1066	1048	1052	1055									
			HS HI	1798	1781	1764	1738	1711	1688	1665	1630	1595	1555	1514	1420	1239					
			HS MED	1384	1382	1379	1375	1371	1356	1341	1318	1294	1261	1227							
			HS LO	1091	1088	1084	1081	1078	1069	1060											
048	1600	1200	HI	1798	1781	1764	1738	1711	1688	1665	1630	1595	1555	1514	1420	1239					
			MED	1384	1382	1379	1375	1371	1356	1341	1318	1294	1261	1227							
			LO																		
			HS HI	2011	1977	1942	1923	1903	1841	1778	1755	1732	1689	1645	1520	1431	1307	1211			
			HS MED	1881	1858	1834	1807	1780	1746	1711	1676	1640	1604	1567	1469	1378	1286				
			HS LO	1738	1716	1694	1673	1651	1634	1617	1584	1551	1508	1465	1390	1321	1228				
060	1950	1500	HI	2311	2306	2300	2279	2268	2257	2233	2209	2175	2140	2088	1990	1901	1856	1752			
			MED	2058	2049	2039	2028	2016	2000	1983	1966	1949	1935	1920	1874	1807	1750	1670	1582		
			LO	1868	1863	1858	1858	1858	1848	1838	1822	1806	1799	1792	1749	1699	1636	1570			
			HS HI	2510	2498	2486	2471	2455	2440	2424	2401	2377	2348	2318	2247	2161	2078	1986	1855		
			HS MED	2171	2167	2162	2162	2162	2158	2153	2135	2117	2101	2085	2024	1971	1891	1823	1691		
			HS LO	2010	2008	2006	2006	2006	2006	2006	1992	1977	1962	1947	1892	1851					
070	2100	1800	HI	2510	2498	2486	2471	2455	2440	2424	2401	2377	2348	2318	2247	2161	2078	1986	1855		
			MED	2171	2167	2162	2162	2162	2158	2153	2135	2117	2101	2085	2024	1971	1891	1823			
			LO	2010	2008	2006	2006	2006	2006	2006	1992	1977	1962	1947	1892	1851					
			HS HI																		
			HS MED																		
			HS LO																		

LEGEND

ESP — External Static Pressure
 HS — High Static

NOTES:

1. Shaded areas denote ESP where operation is not recommended.
2. Units factory shipped on medium speed. Other speeds require field selection.
3. All airflow is rated and shown above at the lower voltage if unit is dual voltage rated, e.g., 208 v for 208/230 v units.
4. Only two-speed fan (high and medium) available on 575 v units.
5. Data for units 006-012 not available at time of printing.

Table 13 — PSC Blower Motor Performance Data for 50PS Units with HWR

COIL FACE VELOCITY FPM	UNITS WITH REHEAT ESP LOSS				
	018 in. wg	024,030 in. wg	036 in. wg	042,048 in. wg	060,070 in. wg
200	0.037	0.033	0.031	0.028	0.026
250	0.052	0.046	0.042	0.038	0.034
300	0.077	0.066	0.059	0.051	0.044
350	0.113	0.096	0.085	0.073	0.061
400	0.181	0.160	0.145	0.131	0.117
450	0.242	0.226	0.215	0.205	0.194
500	0.360	0.345	0.335	0.326	0.316

LEGEND

ESP — External Static Pressure
 HWR — Hot Water Reheat

NOTES:

1. For units with HWR coil applications, calculate face velocity of the entering air. From the data table, find ESP for reheat application. The loss includes wet coil loss.
2. Data for units 006-012 not available at time of printing.

PRE-START-UP

System Checkout — When the installation is complete, follow the system checkout procedure outlined below before starting up the system. Be sure:

1. Voltage is within the utilization range specifications of the unit compressor and fan motor and voltage is balanced for 3-phase units.
2. Fuses, breakers and wire are correct size.
3. Low voltage wiring is complete.
4. Piping and system flushing is complete.
5. Air is purged from closed loop system.
6. System is balanced as required. Monitor if necessary.
7. Isolation valves are open.
8. Water control valves or loop pumps are wired.
9. Condensate line is open and correctly pitched.
10. Transformer switched to lower voltage tap if necessary.
11. Blower rotates freely — shipping support is removed.
12. Blower speed is on correct setting.
13. Air filter is clean and in position.
14. Service/access panels are in place.
15. Return-air temperature is between 40 to 80 F heating and 50 to 110 F cooling.
16. Air coil is clean.
17. Control field-selected settings are correct.

AIR COIL — To obtain maximum performance, clean the air coil before starting the unit. A 10% solution of dishwasher detergent and water is recommended for both sides of the coil. Rinse thoroughly with water.

FIELD SELECTABLE INPUTS

Jumpers and DIP (dual in-line package) switches on the control board are used to customize unit operation and can be configured in the field.

IMPORTANT: Jumpers and DIP switches should only be clipped when power to control board has been turned off.

Complete C Control Jumper Settings

WATER COIL FREEZE PROTECTION (FP1) LIMIT SETTING — Select jumper 3 (JW3-FP1 Low Temp) to choose FP1 limit of either 30 F or 10 F. To select 30 F as the limit, DO NOT clip the jumper. To select 10 F as the limit, clip the jumper.

AIR COIL FREEZE PROTECTION (FP2) LIMIT SETTING — Select jumper 2 (JW2-FP2 Low Temp) to choose FP2 limit of either 30 F or 10 F. To select 30 F as the limit, DO NOT clip the jumper. To select 10 F as the limit, clip the jumper.

ALARM RELAY SETTING — Select jumper 1 (JW1-AL2 Dry) to either connect alarm relay terminal (AL2) to 24 vac (R) or to remain as a dry contact (no connection). To connect AL2 to R, DO NOT clip the jumper. To set as dry contact, clip the jumper.

Deluxe D Control Jumper Settings

WATER COIL FREEZE PROTECTION (FP1) LIMIT SETTING — Select jumper 3 (JW3-FP1 Low Temp) to choose FP1 limit of either 30 F or 10 F. To select 30 F as the limit, DO NOT clip the jumper. To select 10 F as the limit, clip the jumper.

AIR COIL FREEZE PROTECTION (FP2) LIMIT SETTING — Select jumper 2 (JW2-FP2 Low Temp) to choose FP2 limit of either 30 F or 10 F. To select 30 F as the limit, DO NOT clip the jumper. To select 10 F as the limit, clip the jumper.

ALARM RELAY SETTING — Select jumper 4 (JW4-AL2 Dry) to either connect alarm relay terminal (AL2) to 24 vac (R) or to remain as a dry contact (no connection). To connect AL2 to R, DO NOT clip the jumper. To set as dry contact, clip the jumper.

LOW PRESSURE SETTING — The Deluxe D control can be configured for Low Pressure Setting (LP). Select jumper 1 (JW1-LP Norm Open) for choosing between low pressure input normally opened or closed. To configure for normally closed operation, DO NOT clip the jumper. To configure for normally open operation, clip the jumper.

Complete C Control DIP Switches — The Complete C control has 1 DIP (dual in-line package) switch bank with five switches labeled SW1. See Fig. 15, 17, 18, 20, 21, or 23.

PERFORMANCE MONITOR (PM) — The PM is a unique feature that monitors water temperature and will display a warning when heat pump is beyond typical operating range. Refer to Control Operation section for detailed information. DIP switch 1 will enable or disable this feature. To enable the PM, set the switch to ON. To disable the PM, set the switch to OFF.

STAGE 2 — DIP switch 2 will enable or disable compressor delay. Set DIP switch to OFF for stage 2 in which the compressor will have a 3-second delay before energizing.

NOTE: The alarm relay will not cycle during Test mode if switch is set to OFF, stage 2.

SWITCH 3 — Not used.

DDC OUTPUT AT EH2 — Switch 4 provides a selection for Direct Digital Control (DDC) operation. If set to DDC output at EH2, the EH2 terminal will continuously output the last fault code of the controller. If the control is set to EH2 Normal, then EH2 will operate as standard electric heat output. Set the switch to ON to set the EH2 to normal. Set the switch to OFF to set the DDC output at EH2.

FACTORY SETTING — Switch 5 is set to ON. Do not change the switch to OFF unless instructed to do so by the factory.

Deluxe D Control DIP Switches — The Deluxe D control has 2 DIP (dual in-line package) switch banks. Each bank has 8 switches and is labeled either S1 or S2 on the circuit board. See Fig. 16, 19, 22, or 24.

DIP SWITCH BANK 1 (S1) — This set of switches offers the following options for Deluxe D control configuration:

Performance Monitor (PM) — The PM is a unique feature that monitors water temperature and will display a warning when heat pump is beyond typical operating range. Set switch 1 to enable or disable performance monitor. To enable the PM, set the switch to ON. To disable the PM, set the switch to OFF.

Compressor Relay Staging Operation — Switch 2 will enable or disable compressor relay staging operation. The compressor relay can be set to turn on with stage 1 or stage 2 call from the thermostat. This setting is used with dual stage units (units with 2 compressors and 2 Deluxe D controls) or in master/slave applications. In master/slave applications, each compressor and fan will stage according to its switch 2 setting. If switch is set to stage 2, the compressor will have a 3-second delay before energizing during stage 2 demand.

NOTE: If DIP switch is set for stage 2, the alarm relay will not cycle during Test mode.

Heating/Cooling Thermostat Type — Switch 3 provides selection of thermostat type. Heat pump or heat/cool thermostats can be selected. Select OFF for heat/cool thermostats. When in heat/cool mode, Y1 is used for cooling stage 1, Y2 is used for cooling stage 2, W1 is used for heating stage 1 and O/W2 is used for heating stage 2. Select ON for heat pump thermostats. In heat pump mode, Y1 used is for compressor stage 1, Y2 is used for compressor stage 2, W1 is used for heating stage 3 or emergency heat, and O/W2 is used for reversing valve (heating or cooling) depending upon switch 4 setting.

O/B Thermostat Type — Switch 4 provides selection for heat pump O/B thermostats. O is cooling output. B is heating output. Select ON for thermostats with O output. Select OFF for thermostats with B output.

Dehumidification Fan Mode — Switch 5 provides selection of normal or dehumidification fan mode. Select OFF for dehumidification mode. The fan speed relay will remain OFF during cooling stage 2. Select ON for normal mode. The fan speed relay will turn on during cooling stage 2 in normal mode.

Output — Switch 6 provides selection for DDC operation. If set to DDC output at EH2, the EH2 terminal will continuously output the last fault code of the controller. If the control is set to EH2 normal, then the EH2 will operate as standard electric heat output. Set the switch to ON to set the EH2 to normal. Set the switch to OFF to set the DDC output at EH2.

Boilerless Operation — Switch 7 provides selection of boilerless operation and works in conjunction with switch 8. In boilerless operation mode, only the compressor is used for heating when FP1 is above the boilerless changeover temperature set by switch 8 below. Select ON for normal operation or select OFF for boilerless operation.

Boilerless Changeover Temperature — Switch 8 on S1 provides selection of boilerless changeover temperature set point. Select OFF for set point of 50 F or select ON for set point of 40 F.

If switch 8 is set for 50 F, then the compressor will be used for heating as long as the FP1 is above 50 F. The compressor will not be used for heating when the FP1 is below 50 F and the compressor will operate in emergency heat mode, staging on EH1 and EH2 to provide heat. If a thermal switch is being used instead of the FP1 thermistor, only the compressor will be used for heating mode when the FP1 terminals are closed. If the FP1 terminals are open, the compressor is not used and the control goes into emergency heat mode.

DIP SWITCH BANK 2 (S2) — This set of DIP switches is used to configure accessory relay options.

Switches 1 to 3 — These DIP switches provide selection of Accessory 1 relay options. See Table 14 for DIP switch combinations.

Switches 4 to 6 — These DIP switches provide selection of Accessory 2 relay options. See Table 15 for DIP switch combinations.

Table 14 — DIP Switch Block S2 — Accessory 1 Relay Options

ACCESSORY 1 RELAY OPTIONS	DIP SWITCH POSITION		
	1	2	3
Cycle with Fan	On	On	On
Digital NSB	Off	On	On
Water Valve — Slow Opening	On	Off	On
OAD	On	On	Off
Reheat — Humidistat	Off	Off	Off
Reheat — Dehumidistat	Off	On	Off

LEGEND

NSB — Night Setback
OAD — Outside Air Damper

NOTE: All other DIP switch combinations are invalid.

Table 15 — DIP Switch Block S2 — Accessory 2 Relay Options

ACCESSORY 2 RELAY OPTIONS	DIP SWITCH POSITION		
	4	5	6
Cycle with Compressor	On	On	On
Digital NSB	Off	On	On
Water Valve — Slow Opening	On	Off	On
OAD	On	On	Off

LEGEND

NSB — Night Setback
OAD — Outside Air Damper

NOTE: All other switch combinations are invalid.

Auto Dehumidification Mode or High Fan Mode — Switch 7 provides selection of auto dehumidification fan mode or high fan mode. In auto dehumidification fan mode, the fan speed relay will remain off during cooling stage 2 if terminal H is active. In high fan mode, the fan enable and fan speed relays will turn on when terminal H is active. Set the switch to ON for auto dehumidification fan mode or to OFF for high fan mode.

Factory Setting — Switch 8 is set to ON. Do not change the switch to OFF unless instructed to do so by the factory.

Units with Modulating Hot Water Reheat (HWR) Option — A heat pump equipped with hot water reheat (HWR) can operate in three modes: cooling, cooling with reheat, and heating. The cooling and heating modes are like any other water source heat pump. The reversing valve ("O" signal) is energized in cooling, along with the compressor contactor(s) and blower relay. In the heating mode, the reversing valve is deenergized. Almost any thermostat will activate the heat pump in heating or cooling modes. The Deluxe D microprocessor board, which is standard with the HWR option, will accept either heat pump (Y,O) thermostats or non-heat pump (Y,W) thermostats.

The reheat mode requires either a separate humidistat/dehumidistat or a thermostat that has an integrated dehumidification function for activation. The Deluxe D board is configured to work with either a humidistat or dehumidistat input to terminal "H" (DIP switch settings for the Deluxe D board are shown in Table 16). Upon receiving an "H" input, the Deluxe D board will activate the cooling mode and engage reheat.

The reheat mode requires either a separate humidistat/dehumidistat or a thermostat that has an integrated dehumidification function for activation. The Deluxe D board is configured to work with either a humidistat or dehumidistat input to terminal "H" (DIP switch settings for the Deluxe D board are shown in Table 16). Upon receiving an "H" input, the Deluxe D board will activate the cooling mode and engage reheat.

Table 16 — Humidistat/Dehumidistat Logic and Deluxe D DIP Switch Settings

Sensor	2.1	2.2	2.3	Logic	Reheat (ON) - H	Reheat (OFF) - H
Humidistat	Off	Off	Off	Reverse	0 VAC	24 VAC
Dehumidistat	Off	On	Off	Standard	24 VAC	0 VAC

Table 17 shows the relationship between thermostat input signals and unit operation. There are four operational inputs for single-stage units and six operational inputs for dual-stage units:

- Fan Only
- Cooling Stage 1
- Cooling Stage 2
- Heating Stage 1
- Heating Stage 2
- Reheat Mode

HWR APPLICATION CONSIDERATIONS — Unlike most hot gas reheat options, the HWR option will operate over a wide range of entering-water temperatures (EWTs). Special flow regulation (water regulating valve) is not required for low EWT conditions. However, below 55 F, supply-air temperatures cannot be maintained at 72 F because the cooling capacity exceeds the reheat coil capacity at low water temperatures. Below 55 F, essentially all water is diverted to the reheat coil (no heat of rejection to the building loop). Although the HWR option will work fine with low EWTs, overcooling of the space may result with well water systems or, on rare occasions, with ground loop (geothermal) systems (NOTE: Extended range units are required for well water and ground loop systems). Since dehumidification is generally only required in cooling, most ground loop systems will not experience overcooling of the supply-air temperature. If overcooling of the space is a concern (e.g., computer room well water application), auxiliary heating may be required to maintain space temperature when the unit is operating in the dehumidification mode. Water source heat pumps with HWR should not be used as makeup air units. These applications should use equipment specifically designed for makeup air.

HWR COMPONENT FUNCTIONS — The proportional controller operates on 24 VAC power supply and automatically adjusts the water valve based on the supply-air sensor. The supply-air sensor senses supply-air temperature at the blower inlet, providing the input signal necessary for the proportional control to drive the motorized valve during the reheat mode of operation. The motorized valve is a proportional actuator/three-way valve combination used to divert the condenser water from the coax to the hydronic reheat coil during the reheat mode of operation. The proportional controller sends a signal to the motorized valve based on the supply-air temperature reading from the supply air sensor.

The loop pump circulates condenser water through the hydronic reheat coil during the reheat mode of operation (refer to Fig. 34). In this application, the loop pump is only energized during the reheat mode of operation. The hydronic coil is utilized during the reheat mode of operation to reheat the air to the set point of the proportional controller. Condenser water is diverted by the motorized valve and pumped through the hydronic coil by the loop pump in proportion to the control set point. The amount of reheating is dependent on the set point and how far from the set point the supply air temperature is. The factory set point is 70 to 75 F, generally considered "neutral" air.

Table 17 — HWR Operating Modes

MODE	INPUT					OUTPUT				
	O	G	Y1	Y2*	H	O	G	Y1	Y2*	Reheat
No Demand	On/Off	Off	Off	Off	Off	On/Off	Off	Off	Off	Off
Fan Only	On/Off	On	Off	Off	Off	On/Off	On	Off	Off	Off
Cooling Stage 1	On	On	On	Off	Off	On	On	On	Off	Off
Cooling Stage 2	On	On	On	On	Off	On	On	On	On	Off
Cooling and Dehumidistat†	On	On	On	On/Off	On	On	On	On	On/Off	Off
Dehumidistat Only	On/Off	Off	Off	Off	On	On	On	On	On	On
Heating Stage 1	Off	On	On	Off	Off	Off	On	On	Off	Off
Heating Stage 2	Off	On	On	On	Off	Off	On	On	On	Off
Heating and Dehumidistat**	Off	On	On	On/Off	On	Off	On	On	On/Off	Off

*Not applicable for single stage units; Full load operation for dual capacity units.

†Cooling input takes priority over dehumidify input.

**Deluxe D is programmed to ignore the H demand when the unit is in heating mode.

NOTE: On/Off is either on or off.

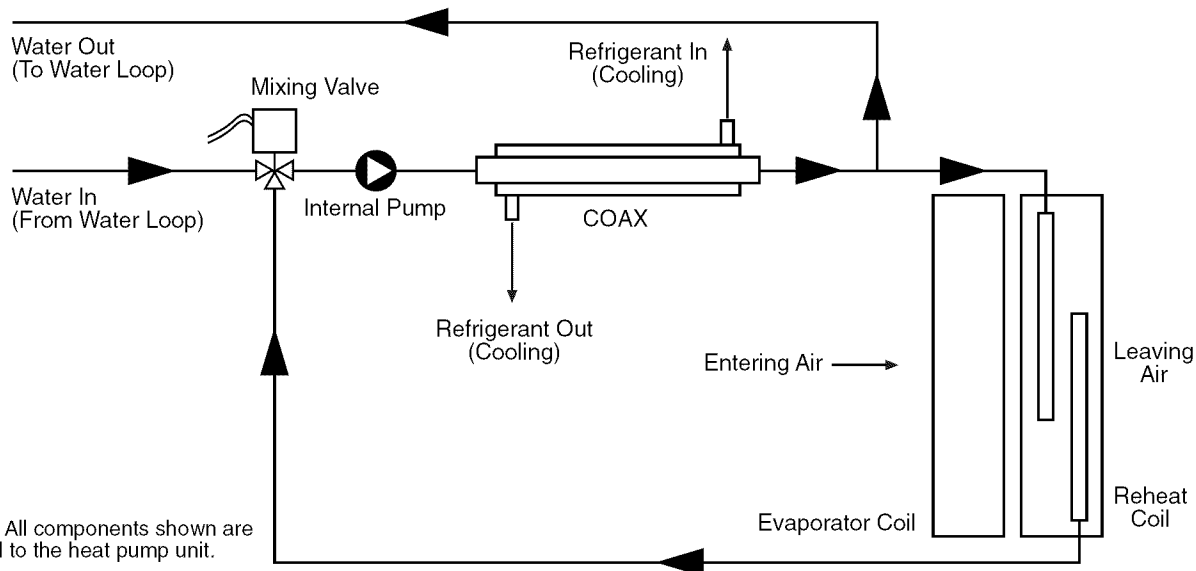

NOTE: All components shown are internal to the heat pump unit.

Fig. 34 — HWR Schematic

Deluxe D Control Accessory Relay Configurations — The following accessory relay settings are applicable for Deluxe D control:

CYCLE WITH FAN — In this configuration, the accessory relay 1 will be ON any time the Fan Enable relay is on.

CYCLE WITH COMPRESSOR — In this configuration, the accessory relay 2 will be ON any time the Compressor relay is on.

DIGITAL NIGHT SET BACK (NSB) — In this configuration, the relay will be ON if the NSB input is connected to ground C.

NOTE: If there are no relays configured for digital NSB, then the NSB and override (OVR) inputs are automatically configured for mechanical operation.

MECHANICAL NIGHT SET BACK — When NSB input is connected to ground C, all thermostat inputs are ignored. A thermostat set back heating call will then be connected to the OVR input. If OVR input becomes active, then the Deluxe D control will enter night low limit (NLL) staged heating mode. The NLL staged heating mode will then provide heating during the NSB period.

WATER VALVE (SLOW OPENING) — If relay is configured for Water Valve (slow opening), the relay will start 60 seconds prior to starting compressor relay.

OUTSIDE AIR DAMPER (OAD) — If relay is configured for OAD, the relay will normally be ON any time the Fan Enable relay is energized. The relay will not start for 30 minutes following a return to normal mode from NSB, when NSB is no longer connected to ground C. After 30 minutes, the relay will start if the Fan Enable is set to ON.

⚠ CAUTION

To avoid equipment damage, DO NOT leave system filled in a building without heat during the winter unless antifreeze is added to system water. Condenser coils never fully drain by themselves and will freeze unless winterized with antifreeze.

START-UP

Use the procedure outlined below to initiate proper unit start-up.

NOTE: This equipment is designed for indoor installation only.

Operating Limits

ENVIRONMENT — This equipment is designed for indoor installation ONLY. Extreme variations in temperature, humidity and corrosive water or air will adversely affect the unit performance, reliability and service life.

POWER SUPPLY — A voltage variation of ± 10% of nameplate utilization voltage is acceptable.

UNIT STARTING CONDITIONS — Units start and operate in an ambient temperature of 45 F with entering-air temperature at 50 F, entering-water temperature at 60 F and with both air and water at the flow rates used.

NOTE: These operating limits are not normal or continuous operating conditions. Assume that such a start-up is for the purpose of bringing the building space up to occupancy temperature. See Table 18 for operating limits.

⚠ WARNING

When the disconnect switch is closed, high voltage is present in some areas of the electrical panel. Exercise caution when working with the energized equipment. Failure to heed this warning may result in personal injury.

1. Restore power to system.
2. Turn thermostat fan position to ON. Blower should start.
3. Balance airflow at registers.
4. Adjust all valves to the full open position and turn on the line power to all heat pump units.
5. Operate unit in the cooling cycle. Refer to Table 14 for unit operating limits.

NOTE: Three factors determine the operating limits of a unit: (1) entering air temperature, (2) water temperature and (3) ambient temperature. Whenever any of these factors are at a minimum or maximum level, the other two factors must be at a normal level to ensure proper unit operation. See Table 18.

Table 18 — Operating Limits — 50PSH, PSV, PSD Units

AIR LIMITS	COOLING (F)	HEATING (F)
Min. Ambient Air	45	39
Rated Ambient Air	80.6	68
Max. Ambient Air	110	85
Min. Entering Air	50	40
Rated Entering Air db/wb	80/67	68
Max. Entering Air db/wb	110/83	80
WATER LIMITS		
Min. Entering Water	30	20
Normal Entering Water	50-110	30-70
Max. Entering Water	120	90

LEGEND
db — Dry Bulb
wb — Wet Bulb
NOTE: Value in heating column is dry bulb only. Any wet bulb reading is acceptable.

Scroll Compressor Rotation — It is important to be certain compressor is rotating in the proper direction. To determine whether or not compressor is rotating in the proper direction:

1. Connect service gages to suction and discharge pressure fittings.
2. Energize the compressor.
3. The suction pressure should drop and the discharge pressure should rise, as is normal on any start-up.

If the suction pressure does not drop and the discharge pressure does not rise to normal levels:

1. Turn off power to the unit. Install disconnect tag.
2. Reverse any two of the unit power leads.
3. Reapply power to the unit and verify pressures are correct.

The suction and discharge pressure levels should now move to their normal start-up levels.

When the compressor is rotating in the wrong direction, the unit makes more noise and does not provide cooling.

After a few minutes of reverse operation, the scroll compressor internal overload protection will open, thus activating the unit lockout. This requires a manual reset. To reset, turn the thermostat on and then off.

NOTE: There is a 5-minute time delay before the compressor will start.

Unit Start-Up Cooling Mode

1. Adjust the unit thermostat to the warmest position. Slowly reduce the thermostat position until the compressor activates.
2. Check for cool air delivery at unit grille a few minutes after the unit has begun to operate.
3. Verify that the compressor is on and that the water flow rate is correct by measuring pressure drop through the heat exchanger using P/T plugs. See Table 19. Check the elevation and cleanliness of the condensate lines; any dripping could be a sign of a blocked line. Be sure the condensate trap includes a water seal.

- Check the temperature of both supply and discharge water. Compare to Tables 20-30. If temperature is within range, proceed. If temperature is outside the range, check the cooling refrigerant pressures in Tables 20-30.
- Check air temperature drop across the coil when compressor is operating. Air temperature drop should be between 15 and 25 F.

Table 19 — Water Temperature Change through Heat Exchanger

WATER FLOW RATE (GPM)	COOLING RISE (F)		HEATING DROP (F)	
	Min	Max	Min	Max
For Closed Loop: Ground Source or Cooling/Boiler Systems at 3 gpm/ton	9	12	4	8
For Open Loop: Ground Water Systems at 1.5 gpm/ton	20	26	10	17

Unit Start-Up Heating Mode

NOTE: Operate the unit in heating cycle after checking the cooling cycle. Allow 5 minutes between tests for the pressure or reversing valve to equalize.

- Turn thermostat to lowest setting and set thermostat switch to HEAT position.
- Slowly turn the thermostat to a higher temperature until the compressor activates.
- Check for warm air delivery at the unit grille within a few minutes after the unit has begun to operate.
- Check the temperature of both supply and discharge water. Compare to Tables 20-30. If temperature is within range, proceed. If temperature is outside the range, check the heating refrigerant pressures in Tables 20-30.
- Once the unit has begun to run, check for warm air delivery at the unit grille.
- Check air temperature rise across the coil when compressor is operating. Air temperature rise should be between 20 and 30 F after 15 minutes at load.
- Check for vibration, noise and water leaks.

Table 20 — 50PSH, PSV, PSD006 Typical Unit Operating Pressures and Temperatures

ENTERING WATER TEMP (F)	WATER FLOW (GPM/ton)	FULL LOAD COOLING — WITHOUT HWG ACTIVE						FULL LOAD HEATING — WITHOUT HWG ACTIVE					
		Suction Pressure (psig)	Discharge Pressure (psig)	Super-heat (F)	Sub-cooling (F)	Water Temp Rise (F)	Air Temp Drop (F) DB	Suction Pressure (psig)	Discharge Pressure (psig)	Super-heat (F)	Sub-cooling (F)	Water Temp Drop (F)	Air Temp Rise (F) DB
30	1.5	114-124	142-162	24-29	3-8	15.2-17.2	17-23	75-85	272-292	13-18	4- 9	5.9- 7.9	16-22
	2.25	111-121	132-152	26-31	3-8	11.4-13.4	17-23	78-88	274-294	13-18	4- 9	4.3- 6.3	16-22
	3	109-119	122-142	28-33	3-8	7.5-9.5	17-23	81-91	276-296	13-18	4- 9	2.7- 4.7	17-23
50	1.5	130-140	190-210	14-19	2-7	16.5-18.5	18-24	104-114	299-319	12-17	6-11	8.8-10.8	21-27
	2.25	129-139	180-200	16-21	2-7	12.3-14.3	18-24	112-122	304-324	12-17	4- 9	6.7- 8.7	22-28
	3	128-138	170-190	19-24	2-7	8.00-10.0	18-24	120-130	308-328	12-17	3- 8	4.5- 6.5	23-29
70	1.5	143-153	265-285	9-14	2-7	15.5-17.5	18-24	129-139	321-341	11-16	7-12	11.2-13.2	25-31
	2.25	141-151	252-272	10-15	2-7	11.5-13.5	18-24	144-154	330-350	13-18	4- 9	8.8- 10.8	27-33
	3	140-150	240-260	11-16	2-7	7.5-9.5	18-24	159-169	340-360	15-20	3- 8	6.3- 8.3	28-34
90	1.5	149-159	340-370	8-13	2-7	14.2-16.2	17-23	163-173	349-369	13-18	7-12	14.3-16.3	30-36
	2.25	149-159	335-355	8-13	2-7	10.6-12.6	17-23	180-190	360-380	11-16	4- 9	11.2-13.2	32-38
	3	148-158	320-340	8-13	2-7	7.00-9.00	17-23	198-208	372-392	10-15	3- 8	8.1-10.1	34-40
110	1.5	154-164	451-471	8-13	2-7	12.7-14.7	15-21	—	—	—	—	—	—
	2.25	154-164	428-448	8-13	2-7	9.5-11.5	15-21	—	—	—	—	—	—
	3	153-163	405-425	8-13	2-7	6.5-8.5	15-21	—	—	—	—	—	—

LEGEND

- DB — Dry Bulb
 HWG — Hot Water Generator
 — — No Heating Operation in This Temperature Range

Table 21 — 50PSH, PSV, PSD009 Typical Unit Operating Pressures and Temperatures

ENTERING WATER TEMP (F)	WATER FLOW (GPM/ton)	FULL LOAD COOLING — WITHOUT HWG ACTIVE						FULL LOAD HEATING — WITHOUT HWG ACTIVE					
		Suction Pressure (psig)	Discharge Pressure (psig)	Super-heat (F)	Sub-cooling (F)	Water Temp Rise (F)	Air Temp Drop (F) DB	Suction Pressure (psig)	Discharge Pressure (psig)	Super-heat (F)	Sub-cooling (F)	Water Temp Drop (F)	Air Temp Rise (F) DB
30	1.5	126-136	161-181	17-22	8-13	19.8-21.8	21-27	74-84	278-298	6-11	4-9	6.1-8.1	18-24
	2.25	126-136	146-166	17-22	7-12	14.9-16.9	21-27	77-87	280-300	6-11	4-9	4.5-6.5	18-24
	3	126-136	131-151	17-22	6-11	9.9-11.9	21-27	79-89	283-303	6-11	3-8	2.8-4.8	19-25
50	1.5	132-142	215-235	10-15	8-13	18.8-20.8	20-26	104-114	309-329	8-12	7-12	9.6-11.6	24-30
	2.25	132-142	200-220	10-15	7-12	14.1-16.1	20-26	106-116	312-332	8-12	7-12	7.0-9.0	24-30
	3	132-142	185-205	10-15	6-11	9.4-11.4	20-26	108-118	315-335	8-12	7-12	4.5-6.5	25-31
70	1.5	138-148	278-298	8-13	9-14	17.7-19.7	19-25	127-137	332-352	10-15	10-15	12.0-14.0	29-35
	2.25	138-148	263-283	8-13	8-13	13.1-15.1	19-25	132-142	340-360	11-16	10-15	9.0-10	29-35
	3	137-147	248-268	8-13	7-12	8.5-10.5	19-25	138-148	347-367	13-18	10-15	6.1-8.1	30-36
90	1.5	142-152	365-385	8-13	9-14	16.0-18.0	18-24	164-174	372-392	17-22	13-18	14.5-16.5	35-41
	2.25	142-152	351-371	8-13	8-13	12.0-14.0	18-24	165-175	375-395	18-23	13-18	11.2-13.2	35-41
	3	142-152	337-357	8-13	7-12	8.0-10.0	18-24	167-177	379-399	19-24	13-18	7.9-9.9	36-42
110	1.5	150-160	439-459	7-12	9-14	14.2-16.2	17-23	—	—	—	—	—	—
	2.25	150-160	439-459	7-12	8-13	10.6-12.6	17-23	—	—	—	—	—	—
	3	150-160	439-459	7-12	7-12	6.9-8.9	17-23	—	—	—	—	—	—

LEGEND

- DB — Dry Bulb
 HWG — Hot Water Generator
 — — No Heating Operation in This Temperature Range

Table 22 — 50PSH, PSV, PSD012 Typical Unit Operating Pressures and Temperatures

ENTERING WATER TEMP (F)	WATER FLOW (GPM/ton)	FULL LOAD COOLING — WITHOUT HWG ACTIVE						FULL LOAD HEATING — WITHOUT HWG ACTIVE					
		Suction Pressure (psig)	Discharge Pressure (psig)	Super-heat (F)	Sub-cooling (F)	Water Temp Rise (F)	Air Temp Drop (F) DB	Suction Pressure (psig)	Discharge Pressure (psig)	Super-heat (F)	Sub-cooling (F)	Water Temp Drop (F)	Air Temp Rise (F) DB
30	1.5	98-108	140-160	36-41	14-19	17.1-19.1	19-25	72-82	301-321	9-14	12-17	6.5-8.5	21-27
	2.25	98-108	135-155	36-41	12-17	12.5-14.5	19-25	85-95	304-324	9-14	12-17	4.7-6.7	21-27
	3	99-109	127-148	36-41	10-15	7.9-9.9	19-25	78-88	308-328	9-14	12-17	2.9-4.9	22-28
50	1.5	118-128	215-235	22-27	14-19	18.1-20.1	20-26	100-110	337-357	10-15	15-20	9.5-11.5	26-32
	2.25	118-128	200-220	22-27	12-17	13.1-15.1	20-26	98-108	334-354	10-15	15-20	6.6-8.6	26-32
	3	118-128	185-205	22-27	10-15	8.1-10.1	19-25	95-105	332-352	11-16	15-20	3.8-5.8	26-32
70	1.5	132-142	300-320	11-16	12-17	17.0-19.0	19-25	115-125	361-381	19-24	18-23	11.1-13.1	29-35
	2.25	132-142	263-282	11-16	10-15	12.6-14.6	19-25	112-122	360-380	20-25	18-23	8.0-10.0	29-35
	3	132-142	245-265	12-17	7-12	8.2-10.2	19-25	110-120	356-376	21-26	18-23	4.8-6.8	29-35
90	1.5	138-148	366-386	9-14	11-16	15.8-17.8	18-24	122-132	376-396	34-39	22-27	12.1-14.1	32-38
	2.25	138-148	353-373	9-14	9-14	14.9-16.9	18-24	123-133	378-398	36-41	22-27	9.0-11.0	32-38
	3	138-148	340-360	9-14	6-11	14.0-16.0	18-24	124-134	380-400	38-43	23-28	5.8-7.8	32-38
110	1.5	145-155	453-473	9-14	9-14	14.7-16.7	16-22	—	—	—	—	—	—
	2.25	145-155	442-462	9-14	7-12	10.8-12.8	16-22	—	—	—	—	—	—
	3	145-155	431-451	9-14	5-10	6.8-8.8	17-23	—	—	—	—	—	—

LEGEND

DB — Dry Bulb
 HWG — Hot Water Generator
 — — No Heating Operation in This Temperature Range

Table 23 — 50PSH, PSV, PSD018 Typical Unit Operating Pressures and Temperatures

ENTERING WATER TEMP (F)	WATER FLOW (GPM/ton)	FULL LOAD COOLING — WITHOUT HWG ACTIVE						FULL LOAD HEATING — WITHOUT HWG ACTIVE					
		Suction Pressure (psig)	Discharge Pressure (psig)	Super-heat (F)	Sub-cooling (F)	Water Temp Rise (F)	Air Temp Drop (F) DB	Suction Pressure (psig)	Discharge Pressure (psig)	Super-heat (F)	Sub-cooling (F)	Water Temp Drop (F)	Air Temp Rise (F) DB
30	1.5	120-130	155-175	27-32	11-16	16.9-19.9	16-22	73- 83	268-288	8-13	4- 9	6.1- 8.1	15-21
	2.25	120-130	142-162	27-32	9-14	12.5-14.5	17-23	75- 85	270-290	8-13	4- 9	4.4- 6.4	16-22
	3	120-130	128-148	27-32	9-14	8.1-10.1	17-23	78- 88	272-292	8-13	4- 9	2.9- 4.9	16-22
50	1.5	137-147	220-240	16-21	10-15	17.0-19.0	16-22	102-112	295-315	8-13	8-13	9.1-11.1	20-26
	2.25	137-147	206-226	16-21	8-13	12.6-14.6	17-23	106-116	297-317	8-13	8-13	6.9- 8.9	21-27
	3	137-147	192-212	16-21	8-13	8.4-10.4	17-23	110-120	299-319	8-13	8-13	4.7- 6.7	21-27
70	1.5	142-152	287-307	7-12	10-15	15.9-17.9	16-22	131-141	324-344	9-14	10-15	12.1-14.1	25-33
	2.25	142-152	273-293	7-12	8-13	11.8-13.8	17-23	137-147	326-346	9-14	10-15	9.3-11.3	26-34
	3	142-152	259-279	7-12	8-13	7.8- 9.8	17-23	144-154	328-348	9-14	10-15	6.6- 8.6	26-34
90	1.5	146-156	375-395	6-11	10-15	14.9-16.9	16-22	174-184	360-380	10-15	12-17	15.8-17.8	32-40
	2.25	146-156	361-381	6-11	8-13	11.0-13.0	17-23	180-190	367-387	11-16	12-17	11.9-13.9	33-41
	3	146-156	347-367	6-11	8-13	7.2- 9.2	17-23	187-197	374-394	12-17	12-17	8.0-10.0	33-41
110	1.5	154-164	478-498	6-11	10-15	14.0-16.0	16-22	—	—	—	—	—	—
	2.25	154-164	461-481	6-11	8-13	10.2-12.2	16-22	—	—	—	—	—	—
	3	154-164	445-465	6-11	8-13	6.5- 8.5	16-22	—	—	—	—	—	—

LEGEND

DB — Dry Bulb
 HWG — Hot Water Generator
 — — No Heating Operation in This Temperature Range

Table 24 — 50PSH, PSV, PSD024 Typical Unit Operating Pressures and Temperatures

ENTERING WATER TEMP (F)	WATER FLOW (GPM/ton)	FULL LOAD COOLING — WITHOUT HWG ACTIVE						FULL LOAD HEATING — WITHOUT HWG ACTIVE					
		Suction Pressure (psig)	Discharge Pressure (psig)	Super-heat (F)	Sub-cooling (F)	Water Temp Rise (F)	Air Temp Drop (F) DB	Suction Pressure (psig)	Discharge Pressure (psig)	Super-heat (F)	Sub-cooling (F)	Water Temp Drop (F)	Air Temp Rise (F) DB
30	1.5	115-125	154-174	40-45	8-13	16.5-18.5	19-25	73- 83	283-303	8-12	6-11	5.9- 7.9	16-22
	2.25	115-125	141-161	40-45	6-11	12.1-14.1	20-26	75- 85	285-305	8-12	6-11	4.2- 6.2	17-23
	3	115-125	127-147	40-45	6-11	7.7- 9.7	20-26	78- 88	287-307	8-12	6-11	2.7- 4.7	18-24
50	1.5	115-120	209-229	24-29	10-15	15.7-17.7	18-24	102-112	313-333	8-12	8-13	8.9-10.9	22-28
	2.25	115-120	195-215	24-29	8-13	11.6-13.6	18-24	106-116	314-334	8-12	8-13	6.7- 8.7	23-29
	3	115-120	181-201	24-29	8-13	7.6- 9.6	18-24	110-120	316-336	8-12	8-13	4.5- 6.5	23-29
70	1.5	136-146	275-295	6-11	6-11	15.7-17.7	18-24	128-138	340-360	9-14	9-14	11.3-13.3	27-34
	2.25	136-146	261-281	6-11	5-10	11.6-13.6	18-24	134-144	342-362	9-14	9-14	8.5-10.5	28-35
	3	136-146	247-267	6-11	4- 9	7.6- 9.6	18-24	141-151	344-364	9-14	9-14	5.8- 7.8	28-35
90	1.5	140-150	361-381	6-11	6-11	14.9-16.9	18-24	162-172	370-390	14-19	9-14	14.4-16.4	32-40
	2.25	140-150	347-367	6-11	5-10	11.0-13.0	18-24	166-176	376-396	15-20	9-14	10.8-12.8	34-42
	3	140-150	333-353	6-11	4- 9	7.2- 9.2	18-24	171-181	383-403	16-21	9-14	7.1- 9.1	34-42
110	1.5	144-154	460-480	6-11	6-11	13.9-15.9	17-23	—	—	—	—	—	—
	2.25	144-154	445-465	6-11	4- 9	10.2-12.2	17-23	—	—	—	—	—	—
	3	144-154	428-448	6-11	4- 9	6.5- 8.5	17-23	—	—	—	—	—	—

LEGEND

DB — Dry Bulb
 HWG — Hot Water Generator
 — — No Heating Operation in This Temperature Range

Table 25 — 50PSH, PSV, PSD030 Typical Unit Operating Pressures and Temperatures

ENTERING WATER TEMP (F)	WATER FLOW (GPM/ton)	FULL LOAD COOLING — WITHOUT HWG ACTIVE						FULL LOAD HEATING — WITHOUT HWG ACTIVE					
		Suction Pressure (psig)	Discharge Pressure (psig)	Super-heat (F)	Sub-cooling (F)	Water Temp Rise (F)	Air Temp Drop (F) DB	Suction Pressure (psig)	Discharge Pressure (psig)	Super-heat (F)	Sub-cooling (F)	Water Temp Drop (F)	Air Temp Rise (F) DB
30	1.5	116-126	146-166	27-32	7-13	19.6-21.6	16-22	69- 79	275-295	7-12	6-11	7.2- 9.2	16-22
	2.25	115-125	138-158	27-32	6-11	14.3-16.3	17-23	73- 83	277-297	7-12	6-11	5.4- 7.4	17-23
	3	115-125	128-148	27-32	6-11	8.0-10.0	17-23	76- 86	279-299	7-12	6-11	3.5- 5.5	17-23
50	1.5	129-139	217-237	12-17	6-11	20.8-22.8	17-23	96-106	300-320	10-15	9-14	10.5-12.5	21-27
	2.25	128-138	203-223	12-17	5-10	15.0-17.0	18-24	100-110	304-324	10-15	9-14	7.6- 9.6	22-28
	3	128-138	189-209	12-17	5-10	9.2-11.2	18-24	105-115	309-329	10-15	9-14	4.8- 6.8	22-28
70	1.5	132-142	293-313	9-14	6-11	20.1-22.1	17-23	123-133	327-347	11-16	11-16	13.2-15.2	25-32
	2.25	131-141	274-294	9-14	5-10	14.4-16.4	18-24	129-139	333-353	11-16	11-16	9.8-11.8	26-33
	3	131-141	256-276	9-14	5-10	8.6-10.6	18-24	135-145	339-359	11-16	11-16	6.4- 8.4	27-34
90	1.5	137-147	383-403	7-12	5-10	19.4-21.4	16-22	155-165	355-375	13-18	11-16	16.8-18.8	30-38
	2.25	137-147	362-382	7-12	5-10	13.8-15.8	16-22	162-172	362-382	14-19	11-16	12.7-14.7	31-39
	3	137-147	342-362	7-12	5-10	8.2-10.2	16-22	169-179	369-389	16-21	11-16	8.6-10.6	32-40
110	1.5	143-153	475-495	6-11	9-14	18.2-20.2	16-22	—	—	—	—	—	—
	2.25	143-153	457-477	6-11	6-11	13.0-14.0	16-22	—	—	—	—	—	—
	3	143-153	439-459	6-11	6-11	7.7- 9.7	16-22	—	—	—	—	—	—

LEGEND

DB — Dry Bulb
 HWG — Hot Water Generator
 — — No Heating Operation in This Temperature Range

Table 26 — 50PSH, PSV, PSD036 Typical Unit Operating Pressures and Temperatures

ENTERING WATER TEMP (F)	WATER FLOW (GPM/ton)	FULL LOAD COOLING — WITHOUT HWG ACTIVE						FULL LOAD HEATING — WITHOUT HWG ACTIVE					
		Suction Pressure (psig)	Discharge Pressure (psig)	Super-heat (F)	Sub-cooling (F)	Water Temp Rise (F)	Air Temp Drop (F) DB	Suction Pressure (psig)	Discharge Pressure (psig)	Super-heat (F)	Sub-cooling (F)	Water Temp Drop (F)	Air Temp Rise (F) DB
30	1.5	117-127	142-162	33-38	8-14	19.1-21.1	15-22	69- 79	276-296	10-15	10-15	7.2- 9.2	17-23
	2.25	116-126	134-154	33-38	7-12	13.8-15.8	15-22	73- 83	278-298	10-15	10-15	5.3- 7.3	18-24
	3	116-126	124-144	33-38	7-12	7.4- 9.4	15-22	76- 86	280-300	10-15	10-15	3.5- 5.5	18-24
50	1.5	136-146	211-231	11-16	6-11	20.6-22.6	17-23	99-109	302-322	10-15	13-18	10.6-12.6	22-28
	2.25	136-146	197-217	11-16	5-10	14.8-16.8	17-23	103-113	306-326	10-15	13-18	7.7- 9.7	23-29
	3	136-146	183-203	11-16	5-10	9.0-11.0	17-23	108-118	311-331	10-15	13-18	5.0- 7.0	23-29
70	1.5	137-147	275-295	9-14	10-15	19.0-21.0	18-24	127-137	332-352	10-15	15-20	13.5-15.5	27-34
	2.25	137-147	260-280	9-14	9-14	13.8-15.8	19-25	133-143	338-358	10-15	15-20	10.1-12.1	28-35
	3	137-147	245-265	9-14	9-14	8.0-10.0	19-25	139-149	344-364	10-15	15-20	6.7- 8.7	29-36
90	1.5	142-152	373-393	7-12	10-15	19.5-21.5	17-23	164-174	365-385	11-16	15-20	17.4-19.4	34-42
	2.25	142-152	352-372	8-13	6-11	13.9-15.9	17-23	172-182	372-392	11-16	15-20	13.2-15.2	35-43
	3	142-152	332-352	8-13	6-11	8.3-10.3	17-23	181-191	379-399	12-17	15-20	9.0-11.0	36-44
110	1.5	147-157	467-487	6-11	10-15	16.2-18.2	16-22	—	—	—	—	—	—
	2.25	147-157	448-468	6-11	8-13	11.9-13.9	16-22	—	—	—	—	—	—
	3	147-157	430-450	6-11	7-12	7.6- 9.6	16-22	—	—	—	—	—	—

LEGEND

DB — Dry Bulb
 HWG — Hot Water Generator
 — — No Heating Operation in This Temperature Range

Table 27 — 50PSH, PSV, PSD042 Typical Unit Operating Pressures and Temperatures

ENTERING WATER TEMP (F)	WATER FLOW (GPM/ton)	FULL LOAD COOLING — WITHOUT HWG ACTIVE						FULL LOAD HEATING — WITHOUT HWG ACTIVE					
		Suction Pressure (psig)	Discharge Pressure (psig)	Super-heat (F)	Sub-cooling (F)	Water Temp Rise (F)	Air Temp Drop (F) DB	Suction Pressure (psig)	Discharge Pressure (psig)	Super-heat (F)	Sub-cooling (F)	Water Temp Drop (F)	Air Temp Rise (F) DB
30	1.5	114-124	170-190	27-32	10-15	17.2-19.2	17-23	69- 79	286-306	5-10	5-10	4.5- 6.5	16-22
	2.25	113-123	150-170	27-32	9-14	12.7-14.7	17-23	72- 82	289-309	5-10	6-11	3.9- 5.9	17-23
	3	113-123	131-151	27-32	7-12	8.2-10.2	17-23	75- 85	292-312	6-11	6-11	3.2- 5.2	18-24
50	1.5	130-140	226-246	10-15	6-11	17.8-19.8	20-26	100-110	315-335	7-12	6-11	9.0-11.0	22-28
	2.25	129-139	208-228	10-15	5-10	13.3-15.3	20-26	105-115	322-342	8-13	6-11	7.0- 9.0	23-29
	3	129-139	190-210	10-15	4- 9	8.8-10.8	20-26	110-120	330-350	10-15	7-12	5.0- 7.0	24-30
70	1.5	132-142	290-310	6-11	6-11	17.3-19.3	19-25	131-141	347-367	11-16	6-11	13.4-15.4	29-35
	2.25	131-141	273-293	6-11	5-10	12.8-14.8	19-25	138-148	358-378	13-18	8-13	10.0-12.0	30-36
	3	131-141	255-275	6-11	4- 9	8.3-10.3	19-25	145-155	369-389	16-21	9-14	6.9- 8.9	31-37
90	1.5	136-146	370-390	6-11	6-11	16.0-18.0	17-23	175-185	393-413	19-24	7-12	17.6-19.6	36-42
	2.25	135-145	350-370	6-11	5-10	11.8-13.8	17-23	177-187	401-421	20-25	9-14	13.2-15.2	37-43
	3	135-145	330-350	6-11	4- 9	7.6- 9.6	17-23	180-190	409-429	22-27	12-17	8.7-10.7	38-44
110	1.5	143-153	469-489	6-11	6-11	14.0-16.0	16-22	—	—	—	—	—	—
	2.25	142-152	448-468	6-11	5-10	11.0-13.0	16-22	—	—	—	—	—	—
	3	141-151	427-447	6-11	4- 9	7.0- 9.0	16-22	—	—	—	—	—	—

LEGEND

DB — Dry Bulb
 HWG — Hot Water Generator
 — — No Heating Operation in This Temperature Range

Table 28 — 50PSH, PSV, PSD048 Typical Unit Operating Pressures and Temperatures

ENTERING WATER TEMP (F)	WATER FLOW (GPM/ton)	FULL LOAD COOLING — WITHOUT HWG ACTIVE						FULL LOAD HEATING — WITHOUT HWG ACTIVE					
		Suction Pressure (psig)	Discharge Pressure (psig)	Super-heat (F)	Sub-cooling (F)	Water Temp Rise (F)	Air Temp Drop (F) DB	Suction Pressure (psig)	Discharge Pressure (psig)	Super-heat (F)	Sub-cooling (F)	Water Temp Drop (F)	Air Temp Rise (F) DB
30	1.5	108-118	180-200	27-32	12-17	19.8-21.8	19-25	65- 75	293-313	7-12	9-14	8.2-10.2	17-23
	2.25	107-117	161-181	28-33	10-15	14.8-16.8	19-25	68- 78	297-217	8-13	9-14	6.2- 8.2	18-24
	3	107-117	142-162	29-34	9-14	9.8-11.8	19-25	72- 82	301-321	9-14	9-14	4.2- 6.2	19-25
50	1.5	123-133	236-256	16-21	8-13	20.2-22.2	21-27	92-102	321-341	10-15	11-16	11.6-13.6	23-29
	2.25	122-132	218-238	17-22	7-12	15.2-18.2	21-27	100-110	330-350	11-16	11-16	8.9-10.9	24-30
	3	122-132	200-220	17-22	6-11	10.2-12.2	21-27	108-118	340-360	12-17	11-16	6.0- 8.0	26-32
70	1.5	130-140	305-325	10-15	8-13	20.0-22.0	20-26	122-132	353-373	12-17	11-16	15.0-17.0	29-35
	2.25	129-139	285-305	11-16	6-11	15.0-17.0	20-26	133-143	365-385	14-19	11-16	11.5-13.5	31-37
	3	129-139	265-285	11-16	5-10	10.0-12.0	20-26	144-154	378-398	16-21	11-16	8.0-10.0	33-39
90	1.5	133-143	390-410	8-13	8-13	19.0-21.0	19-25	166-176	397-417	16-21	9-14	19.5-21.5	37-43
	2.25	132-142	368-388	9-14	6-11	14.0-16.0	19-25	173-183	407-427	18-23	9-14	14.7-16.7	38-44
	3	132-142	345-365	9-14	5-10	9.0-11.0	19-25	181-191	417-437	19-24	10-15	9.9-11.9	40-46
110	1.5	141-151	497-517	6-11	8-13	18.0-20.0	18-24	—	—	—	—	—	—
	2.25	140-150	472-492	7-12	6-11	13.5-15.5	18-24	—	—	—	—	—	—
	3	140-150	447-467	8-13	5-10	8.7-10.7	18-24	—	—	—	—	—	—

LEGEND

DB — Dry Bulb
 HWG — Hot Water Generator
 — — No Heating Operation in This Temperature Range

Table 29 — 50PSH, PSV, PSD060 Typical Unit Operating Pressures and Temperatures

ENTERING WATER TEMP (F)	WATER FLOW (GPM/ton)	FULL LOAD COOLING — WITHOUT HWG ACTIVE						FULL LOAD HEATING — WITHOUT HWG ACTIVE					
		Suction Pressure (psig)	Discharge Pressure (psig)	Super-heat (F)	Sub-cooling (F)	Water Temp Rise (F)	Air Temp Drop (F) DB	Suction Pressure (psig)	Discharge Pressure (psig)	Super-heat (F)	Sub-cooling (F)	Water Temp Drop (F)	Air Temp Rise (F) DB
30	1.5	98-108	160-180	40-45	12-17	20.0-22.0	19-25	62- 72	276-296	6-11	6-11	8.0-10.0	17-23
	2.25	97-107	149-169	41-46	12-17	14.3-16.3	19-25	66- 76	280-300	6-11	6-11	6.0- 8.0	18-24
	3	96-106	137-157	42-48	11-16	8.5-10.5	20-26	70- 80	284-304	7-12	6-11	4.0- 6.0	19-25
50	1.5	118-128	225-245	36-41	11-16	21.2-23.2	19-25	88- 98	306-326	10-15	8-13	11.0-13.0	23-29
	2.25	117-127	210-230	37-42	10-15	15.7-17.7	20-26	94- 104	311-331	10-15	8-13	8.3-10.3	24-30
	3	115-125	195-215	38-43	9-14	10.2-12.2	21-27	100-110	317-337	11-16	9-14	5.5- 7.5	25-31
70	1.5	135-145	300-320	12-17	9-14	20.3-22.3	21-27	112-122	333-353	12-17	10-15	14.0-16.0	28-34
	2.25	133-143	285-305	14-19	8-13	15.0-17.0	21-27	122-132	342-362	14-19	10-15	10.5-12.5	30-36
	3	132-142	270-290	16-21	7-12	10.0-12.0	22-28	130-140	351-371	15-20	11-16	7.3- 9.3	32-38
90	1.5	139-149	390-410	8-13	7-12	19.3-21.3	20-26	147-157	369-389	15-20	10-15	17.7-19.7	36-42
	2.25	138-148	370-390	8-13	6-11	14.3-16.3	21-27	154-164	377-397	18-23	10-15	13.4-15.4	37-43
	3	138-148	350-370	8-13	6-11	9.3-11.3	21-27	160-170	385-405	19-24	11-16	9.0-11.0	38-44
110	1.5	144-154	488-508	8-13	8-13	18.4-20.4	21-27	—	—	—	—	—	—
	2.25	143-153	468-488	7-12	6-11	13.6-15.6	21-27	—	—	—	—	—	—
	3	142-152	448-468	7-12	5-10	8.8-10.8	21-27	—	—	—	—	—	—

LEGEND

DB — Dry Bulb
 HWG — Hot Water Generator
 — — No Heating Operation in This Temperature Range

Table 30 — 50PSH, PSV, PSD070 Typical Unit Operating Pressures and Temperatures

ENTERING WATER TEMP (F)	WATER FLOW (GPM/ton)	FULL LOAD COOLING — WITHOUT HWG ACTIVE						FULL LOAD HEATING — WITHOUT HWG ACTIVE					
		Suction Pressure (psig)	Discharge Pressure (psig)	Super-heat (F)	Sub-cooling (F)	Water Temp Rise (F)	Air Temp Drop (F) DB	Suction Pressure (psig)	Discharge Pressure (psig)	Super-heat (F)	Sub-cooling (F)	Water Temp Drop (F)	Air Temp Rise (F) DB
30	1.5	110-120	177-197	36-41	15-20	20.2-22.2	21-27	61- 71	290-310	12-18	9-14	8.0-10.0	19-25
	2.25	109-119	162-182	37-42	13-18	15.0-17.0	21-27	65- 75	292-312	12-18	10-15	6.0- 8.0	20-26
	3	107-117	147-167	38-43	11-16	9.7-11.7	22-28	68- 78	296-316	12-18	10-15	4.0- 6.0	21-27
50	1.5	128-138	246-266	18-23	11-16	21.0-23.0	22-28	88- 98	320-340	11-17	13-18	11.7-13.7	26-32
	2.25	128-138	228-248	19-24	9-14	15.6-17.6	23-29	96-106	330-350	11-17	11-16	9.0-11.0	27-33
	3	127-137	210-230	20-25	6-11	10.2-12.2	24-30	105-115	338-358	11-17	9-14	6.0- 8.0	29-35
70	1.5	134-144	305-325	9-14	11-16	20.8-22.8	23-29	118-128	355-375	10-16	14-19	15.2-17.2	33-39
	2.25	133-143	289-309	9-14	9-14	15.4-17.4	23-29	130-140	368-388	12-18	13-18	11.7-13.7	35-41
	3	131-141	273-293	9-14	6-11	10.0-12.0	23-29	141-151	380-400	15-21	11-16	8.0-10.0	37-43
90	1.5	140-150	390-410	10-15	11-16	19.6-21.6	22-28	158-168	401-421	9-15	13-18	19.5-21.5	41-47
	2.25	139-149	373-393	10-15	9-14	14.5-16.5	22-28	168-178	412-432	10-16	12-17	14.8-16.8	43-49
	3	138-148	355-375	10-15	6-11	9.3-11.3	22-28	178-188	423-443	12-18	12-17	10.0-12.0	45-51
110	1.5	144-154	488-508	10-15	9-14	18.4-20.4	20-27	—	—	—	—	—	—
	2.25	143-153	468-488	10-15	6-11	13.6-15.6	20-27	—	—	—	—	—	—
	3	142-152	448-468	9-14	5-10	8.8-10.8	20-27	—	—	—	—	—	—

LEGEND

DB — Dry Bulb
 HWG — Hot Water Generator
 — — No Heating Operation in This Temperature Range

Unit Start-Up with WSHP Open Controls

The WSHP Open is a multi-protocol (default BACnet*) controller with extensive features, flexible options and powerful capabilities. The unit comes from the factory pre-programmed and needs minimal set up to function in a BAS (Building Automation System) system or provide additional capabilities to Carrier's WSHP product line. Most settings on the controller have factory defaults set for ease of installation. There are a few settings that must be configured in the field and several settings that can be adjusted if required by unique job conditions. Refer to Appendix A — WSHP Open Screen Configuration. In order to configure the unit, a BACview⁶ display is required. See Fig. 35.

NOTE: If the WSHP Open control has lost its programming, all display pixels will be displayed on the SPT sensor. See the WSHP Third Party Integration Guide.

When the unit is OFF, the SPT sensor will indicate OFF. When power is applied, the SPT sensor will indicate temperature in the space at 78 F.

To start-up a unit with WSHP Open controls:

1. To plug in the BACview⁶ handheld display into a SPT sensor, point the two ears on the connector up and tilt the bottom of the plug toward you. Insert the plug up into the SPT sensor while pushing the bottom of the plug away from you.
2. BACview⁶ should respond with "Establishing Connection." The Home screen will then appear on the display showing operating mode and space temperature. Press any button to continue.
See Appendix A — WSHP Open Screen Configuration for the hierarchal structure of the WSHP Open controller. All functions of the controller can be set from the Home screen.
3. When the Login is requested, type 1111 and push the OK softkey. The Logout will then be displayed to indicate the password was accepted.
4. To set the Clock if it is not already displayed:
 - a. Select System Settings from the Home screen, then press Clockset.
 - b. Scroll to hour, minute and second using the arrow keys. Use the number keypad to set actual time.
 - c. Scroll to day, month and year using arrow keys. Use number keypad to set date.
5. To set Daylight Savings Time (DST):
 - a. Push the DST softkey. The display will indicate 02:00:060 which is equal to 2:00AM.

- b. To program the beginning and end dates, scroll down to the beginning month and press the enter key. The softkeys (INCR and DECR) will activate to increment the month in either direction, Jan, Feb, March, etc.
 - c. Use number keys to select the day of month and year.
 - d. Push the OK softkey to finalize the data.
6. To view configuration settings:
 - a. Select the Config softkey.
 - b. Select the Service Config softkey. Scroll through the factory settings by using the up and down arrow keys. See below for factory settings. Only the following settings will need to be checked.
 - # of Fan Speeds — This should be set to "1" for units with PSC motors and set to "3" for units with ECM motors.
 - Compressor Stages — This should be set to "1."
 - Factory Dehumidification Reheat Coil — This should be set to "none" unless the modulating hot water reheat option is supplied in the unit, then set to "installed."
 - The condenser water limit needs to be verified depending on design parameters and application, whether geothermal or boiler/tower.
 7. To view unit configuration settings:
 - a. Select the Unit Configuration softkey, then select Unit.
 - b. Scroll through the unit settings by using the up and down arrow keys. Unit settings include:
 - Fan Mode: Default Continuous
 - Fan Delay:
 - Minimum SAT Cooling: Default 50 F
 - Maximum SAT Heating: Default 110 F
 - Filter Service Alarm: Must be set from 0 to 9999 hr
 8. To set local schedules:
 - a. Select the Schedule softkey from the Configuration screen, then press enter.
 - b. Select Weekly, then press enter (7 schedules available).
 - c. Select day and press enter.
 - d. Press enter again and select ADD or DEL (DECR or INCR) set schedule.
 - e. Enter ON/OFF time, then press continue.

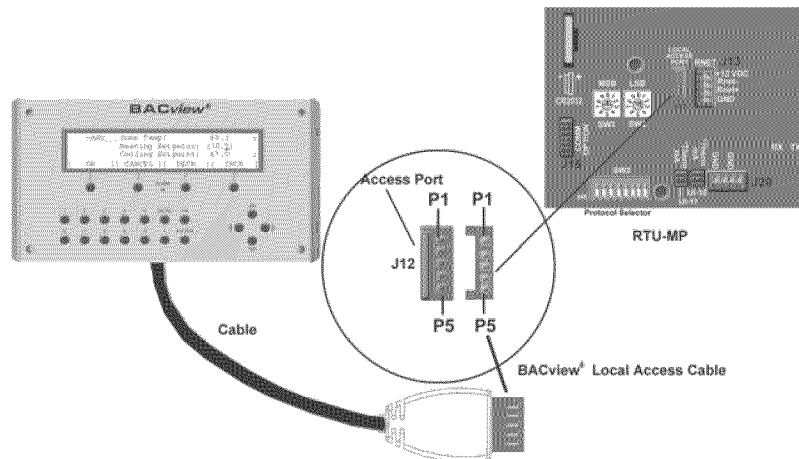

Fig. 35 — BACview⁶ Display Interface

*Sponsored by ASHRAE (American Society of Heating, Refrigerating and Air Conditioning Engineers).

- f. Press OK to apply and save to a particular day of the week.
- g. Continue to add the same or different schedule specific days of the week.
To add exceptions to the schedule:
 - i. Press Add softkey.
 - ii. Select exception type from following:
 - Date
 - Date Range
 - Week-N-Day
 - Calendar Reference
9. Go back to Home Screen.
10. Remove BACview⁶ cable from SPT sensor by reversing the process in Step 1.
11. Perform system test.

Flow Regulation — Flow regulation can be accomplished by two methods. Most water control valves have a flow adjustment built into the valve. By measuring the pressure drop through the unit heat exchanger, the flow rate can be determined. See Table 31. Adjust the water control valve until the flow of 1.5 to 2 gpm is achieved. Since the pressure constantly varies, two pressure gages may be needed in some applications.

Table 31 — 50PSH, PSV, PSD Coaxial Water Pressure Drop

50PSH, PSV, PSD UNIT SIZE	WATER FLOW (GPM)	WATER TEMPERATURE (F)			
		30 F	50 F	70 F	90 F
		Pressure Drop (psi)			
006	1.0	0.3	0.3	0.2	0.2
	1.5	1.6	1.4	1.2	1.0
	2.0	3.0	2.6	2.2	1.8
009	1.4	0.8	0.7	0.6	0.6
	2.1	1.5	1.4	1.2	1.1
	2.8	2.7	2.4	2.2	1.9
012	1.8	0.6	0.5	0.4	0.3
	2.6	2.1	1.9	1.6	1.4
	3.5	3.8	3.4	3.0	2.6
018	2.8	0.7	0.5	0.3	0.2
	4.1	2.1	1.7	1.4	1.1
	5.5	3.5	2.8	2.4	2.0
024	4.0	1.5	1.3	1.1	1.0
	6.0	3.1	2.6	2.3	2.1
	8.0	5.1	4.3	3.8	3.4
030	4.0	1.5	1.3	1.1	1.0
	6.0	3.1	2.6	2.3	2.1
	8.0	5.1	4.3	3.8	3.4
036	4.5	1.7	1.3	1.1	0.9
	6.8	3.3	3.1	2.9	2.6
	9.0	5.7	5.2	4.8	4.4
042	5.5	1.1	0.9	0.8	0.7
	8.3	2.2	2.1	2.0	1.8
	11.0	3.9	3.6	3.2	3.1
048	6.0	1.3	1.1	1.0	0.9
	9.0	2.6	2.5	2.3	2.2
	12.0	4.5	4.2	3.8	3.5
060	7.5	0.6	0.4	0.3	0.2
	11.3	2.3	2.1	2.0	1.8
	15.0	4.8	4.3	3.9	3.5
070	8.3	2.4	2.0	1.7	1.6
	12.4	5.2	4.5	4.0	3.8
	16.5	8.0	7.0	6.3	6.0

An alternative method is to install a flow control device. These devices are typically an orifice of plastic material designed to allow a specified flow rate that are mounted on the outlet of the water control valve. Occasionally these valves produce a velocity noise that can be reduced by applying some back pressure. To accomplish this, slightly close the leaving isolation valve of the well water setup.

⚠ WARNING

To avoid possible injury or death due to electrical shock, open the power supply disconnect switch and secure it in an open position before flushing system.

Flushing — Once the piping is complete, units require final purging and loop charging. A flush cart pump of at least 1.5 hp is needed to achieve adequate flow velocity in the loop to purge air and dirt particles from the loop. Flush the loop in both directions with a high volume of water at a high velocity. Follow the steps below to properly flush the loop:

1. Verify power is off.
2. Fill loop with water from hose through flush cart before using flush cart pump to ensure an even fill. Do not allow the water level in the flush cart tank to drop below the pump inlet line in order to prevent air from filling the line.
3. Maintain a fluid level in the tank above the return tee in order to avoid air entering back into the fluid.
4. Shutting off the return valve that connects into the flush cart reservoir will allow 50 psig surges to help purge air pockets. This maintains the pump at 50 psig.
5. To purge, keep the pump at 50 psig until maximum pumping pressure is reached.
6. Open the return valve to send a pressure surge through the loop to purge any air pockets in the piping system.
7. A noticeable drop in fluid level will be seen in the flush cart tank. This is the only indication of air in the loop.

NOTE: If air is purged from the system while using a 10 in. PVC flush tank, the level drop will only be 1 to 2 in. since liquids are incompressible. If the level drops more than this, flushing should continue since air is still being compressed in the loop. If level is less than 1 to 2 in., reverse the flow.

8. Repeat this procedure until all air is purged.
9. Restore power.

Antifreeze may be added before, during, or after the flushing process. However, depending on when it is added in the process, it can be wasted. Refer to the Antifreeze section for more detail.

Loop static pressure will fluctuate with the seasons. Pressures will be higher in the winter months than during the warmer months. This fluctuation is normal and should be considered when charging the system initially. Run the unit in either heating or cooling for several minutes to condition the loop to a homogenous temperature.

When complete, perform a final flush and pressurize the loop to a static pressure of 40 to 50 psig for winter months or 15 to 20 psig for summer months.

After pressurization, be sure to remove the plug from the end of the loop pump motor(s) to allow trapped air to be discharged and to ensure the motor housing has been flooded. Be sure the loop flow center provides adequate flow through the unit by checking pressure drop across the heat exchanger. Compare the results to the data in Table 31.

Antifreeze — In areas where entering loop temperatures drop below 40 F or where piping will be routed through areas subject to freezing, antifreeze is needed.

Alcohols and glycols are commonly used as antifreeze agents. Freeze protection should be maintained to 15 F below the lowest expected entering loop temperature. For example, if the lowest expected entering loop temperature is 30 F, the leaving loop temperature would be 22 to 25 F. Therefore, the freeze protection should be at 15 F (30 F – 15 F = 15 F).

IMPORTANT: All alcohols should be pre-mixed and pumped from a reservoir outside of the building or introduced under water level to prevent fuming.

Calculate the total volume of fluid in the piping system. See Table 32. Use the percentage by volume in Table 33 to determine the amount of antifreeze to use. Antifreeze concentration should be checked from a well-mixed sample using a hydrometer to measure specific gravity.

FREEZE PROTECTION SELECTION — The 30 F FP1 factory setting (water) should be used to avoid freeze damage to the unit.

Once antifreeze is selected, the JW3 jumper (FP1) should be clipped on the control to select the low temperature (antifreeze 13 F) set point to avoid nuisance faults.

Table 32 — Approximate Fluid Volume (gal.) per 100 Ft of Pipe

PIPE	DIAMETER (in.)	VOLUME (gal.)
Copper	1	4.1
	1.25	6.4
	1.5	9.2
Rubber Hose	1	3.9
Polyethylene	3/4 IPS SDR11	2.8
	1 IPS SDR11	4.5
	1 1/4 IPS SDR11	8.0
	1 1/2 IPS SDR11	10.9
	2 IPS SDR11	18.0
	1 1/4 IPS SCH40	8.3
	1 1/2 IPS SCH40	10.9
	2 IPS SCH40	17.0

LEGEND

- IPS — Internal Pipe Size
- SCH — Schedule
- SDR — Standard Dimensional Ratio

NOTE: Volume of heat exchanger is approximately 1.0 gallon.

Table 33 — Antifreeze Percentages by Volume

ANTIFREEZE	MINIMUM TEMPERATURE FOR FREEZE PROTECTION (F)			
	10	15	20	25
Methanol (%)	25	21	16	10
100% USP Food Grade Propylene Glycol (%)	38	30	22	15
Ethanol (%)	29	25	20	14

Cooling Tower/Boiler Systems — These systems typically use a common loop temperature maintained at 60 to 95 F. Carrier recommends using a closed circuit evaporative cooling tower with a secondary heat exchanger between the tower and the water loop. If an open type cooling tower is used continuously, chemical treatment and filtering will be necessary.

Ground Coupled, Closed Loop and Plateframe Heat Exchanger Well Systems — These systems allow water temperatures from 30 to 110 F. The external loop field is divided up into 2 in. polyethylene supply and return lines. Each line has valves connected in such a way that upon system start-up, each line can be isolated for flushing using only the system pumps. Locate air separation in the piping system prior to the fluid re-entering the loop field.

OPERATION

Power Up Mode — The unit will not operate until all the inputs, terminals and safety controls are checked for normal operation.

NOTE: The compressor will have a 5-minute anti-short cycle upon power up.

Units with Aquazone™ Complete C Control

STANDBY — Y and W terminals are not active in Standby mode, however the O and G terminals may be active, depending on the application. The compressor will be off.

COOLING — Y and O terminals are active in Cooling mode. After power up, the first call to the compressor will initiate a 5 to 80 second random start delay and a 5-minute anti-short cycle protection time delay. After both delays are complete, the compressor is energized.

NOTE: On all subsequent compressor calls the random start delay is omitted.

HEATING STAGE 1 — Terminal Y is active in heating stage 1. After power up, the first call to the compressor will initiate a 5 to 80 second random start delay and a 5-minute anti-short cycle protection time delay. After both delays are complete, the compressor is energized.

NOTE: On all subsequent compressor calls the random start delay is omitted.

HEATING STAGE 2 — To enter Stage 2 mode, terminal W is active (Y is already active). Also, the G terminal must be active or the W terminal is disregarded. The compressor relay will remain on and EH1 is immediately turned on. EH2 will turn on after 10 minutes of continual stage 2 demand.

NOTE: EH2 will not turn on (or if on, will turn off) if FP1 temperature is greater than 45 F and FP2 is greater than 110 F.

LOCKOUT MODE — The status LED will flash fast in Lockout mode and the compressor relay will be turned off immediately. Lockout mode can be “soft” reset via the Y input or can be “hard” reset via the disconnect. The last fault causing the lockout is stored in memory and can be viewed by entering test mode.

LOCKOUT WITH EMERGENCY HEAT — While in Lockout mode, if W becomes active, then Emergency Heat mode will occur.

EMERGENCY HEAT — In Emergency Heat mode, terminal W is active while terminal Y is not. Terminal G must be active or the W terminal is disregarded. EH1 is immediately turned on. EH2 will turn on after 5 minutes of continual emergency heat demand.

Units with Aquazone Deluxe D Control

EXTENDED COMPRESSOR OPERATION MONITOR — If the compressor has been on for 4 continuous hours the control will automatically turn off the compressor relay and wait the short cycle time protection time. All appropriate safeties, including the low-pressure switch, will be monitored. If all operations are normal and the compressor demand is still present, the control will turn the compressor back on.

STANDBY/FAN ONLY — The compressor will be off. The Fan Enable, Fan Speed, and reversing valve (RV) relays will be on if inputs are present. If there is a Fan 1 demand, the Fan Enable will immediately turn on. If there is a Fan 2 demand, the Fan Enable and Fan Speed will immediately turn on.

NOTE: DIP switch 5 on S1 does not have an effect upon Fan 1 and Fan 2 outputs.

HEATING STAGE 1 — In Heating Stage 1 mode, the Fan Enable and Compressor relays are turned on immediately. Once the demand is removed, the relays are turned off and the control reverts to Standby mode. If there is a master/slave or dual compressor application, all compressor relays and related functions will operate per their associated DIP switch 2 setting on S1.

HEATING STAGE 2 — In Heating Stage 2 mode, the Fan Enable and Compressor relays are remain on. The Fan Speed relay is turned on immediately and turned off immediately once the demand is removed. The control reverts to Heating Stage 1 mode. If there is a master/slave or dual compressor

application, all compressor relays and related functions will operate per their associated DIP switch 2 setting on S1.

HEATING STAGE 3 — In Heating Stage 3 mode, the Fan Enable, Fan Speed and Compressor relays remain on. The EH1 output is turned on immediately. With continuing Heat Stage 3 demand, EH2 will turn on after 10 minutes. EH1 and EH2 are turned off immediately when the Heating Stage 3 demand is removed. The control reverts to Heating Stage 2 mode.

The output signal EH2 will be off if FP1 is greater than 45 F AND FP2 (when shorted) is greater than 110 F during Heating Stage 3 mode. This condition will have a 30-second recognition time. Also, during Heating Stage 3 mode, EH1, EH2, Fan Enable, and Fan Speed will be ON if G input is not active.

EMERGENCY HEAT — In Emergency Heat mode, the Fan Enable and Fan Speed relays are turned on. The EH1 output is turned on immediately. With continuing Emergency Heat demand, EH2 will turn on after 5 minutes. Fan Enable and Fan Speed relays are turned off after a 60-second delay. The control reverts to Standby mode.

Output EH1, EH2, Fan Enable, and Fan Speed will be ON if the G input is not active during Emergency Heat mode.

COOLING STAGE 1 — In Cooling Stage 1 mode, the Fan Enable, compressor and RV relays are turned on immediately. If configured as stage 2 (DIP switch set to OFF) then the compressor and fan will not turn on until there is a stage 2 demand. The Fan Enable and compressor relays are turned off immediately when the Cooling Stage 1 demand is removed. The control reverts to Standby mode. The RV relay remains on until there is a heating demand. If there is a master/slave or dual compressor application, all compressor relays and related functions will track with their associated DIP switch 2 on S1.

COOLING STAGE 2 — In Cooling Stage 2 mode, the Fan Enable, compressor and RV relays remain on. The Fan Speed relay is turned on immediately and turned off immediately once the Cooling Stage 2 demand is removed. The control reverts to Cooling Stage 1 mode. If there is a master/slave or dual compressor application, all compressor relays and related functions will track with their associated DIP switch 2 on S1.

NIGHT LOW LIMIT (NLL) STAGED HEATING — In NLL staged Heating mode, the override (OVR) input becomes active and is recognized as a call for heating and the control will immediately go into a Heating Stage 1 mode. With an additional 30 minutes of NLL demand, the control will go into Heating Stage 2 mode. With another additional 30 minutes of NLL demand, the control will go into Heating Stage 3 mode.

Units with HWR Option

FAN ONLY — A (G) call from the thermostat to the (G) terminal of the Deluxe D control board will bring the unit on in fan only mode.

COOLING STAGE 1 — A simultaneous call from (G), (Y1), and (O) to the (G), (Y1), (O/W2) terminals of the Deluxe D control board will bring the unit on in Cooling Stage 1.

COOLING STAGE 2 — A simultaneous call from (G), (Y1), (Y2), and (O) to the (G), (Y1), (Y2), and (O/W2) terminals of the Deluxe D control board will bring the unit on in Cooling Stage 2. When the call is satisfied at the thermostat the unit will continue to run in Cooling Stage 1 until the Cooling Stage 1 call is removed or satisfied, shutting down the unit.

NOTE: Not all units have two-stage cooling functionality.

HEATING STAGE 1 — A simultaneous call from (G) and (Y1) to the (G) and (Y1) terminals of the Deluxe D control board will bring the unit on in Heating Stage 1.

HEATING STAGE 2 — A simultaneous call from (G), (Y1), and (Y2) to the (G), (Y1), and (Y2) terminals of the Deluxe

D control board will bring the unit on in Heating Stage 2. When the call is satisfied at the thermostat the unit will continue to run in Heating Stage 1 until the call is removed or satisfied, shutting down the unit.

NOTE: Not all units have two-stage heating functionality.

REHEAT MODE — A call from the humidistat/dehumidistat to the (H) terminal of the Deluxe D control board will bring the unit on in Reheat mode if there is no call for cooling at the thermostat. When the humidistat/dehumidistat call is removed or satisfied the unit will shut down.

NOTE: Cooling always overrides Reheat mode. In the Cooling mode, the unit cools and dehumidifies. If the cooling thermostat is satisfied but there is still a call for dehumidification, the unit will continue to operate in Reheat mode.

Units with WSHP Open Multiple Protocol —

The WSHP Open multi-protocol controller will control mechanical cooling, heating and waterside economizer outputs based on its own space temperature input and set points. An optional CO₂ IAQ (indoor air quality) sensor mounted in the space can maximize the occupant comfort. The WSHP Open controller has its own hardware clock that is automatically set when the heat pump software is downloaded to the board. Occupancy types are described in the scheduling section below. The following sections describe the functionality of the WSHP Open multi-protocol controller. All point objects referred to in this sequence of operation will be referenced to the objects as viewed in the BACview⁶ handheld user interface.

SCHEDULING — Scheduling is used to start/stop the unit based on a time period to control the space temperature to specified occupied heating and cooling set points. The controller is defaulted to control by occupied set points all the time, until either a time schedule is configured with BACview⁶, Field Assistant, i-Vu[®] Open, or a third party control system to enable/disable the BAS (Building Automation System) on/off point. The local time and date must be set for these functions to operate properly. The occupancy source can be changed to one of the following:

Occupancy Schedules — The controller will be occupied 24/7 until a time schedule has been configured using either Field Assistant, i-Vu Open, BACview⁶ or a third party control system to enable/disable the BAS on/off point. The BAS point can be disabled by going to Config, then Unit, then Occupancy Schedules and changing the point from enable to disable then clicking OK.

NOTE: This point must be enabled in order for the i-Vu Open, Field Assistant, or BACview⁶ control system to assign a time schedule to the controller.

Schedule schedule — The unit will operate according to the schedule configured and stored in the unit. The schedule is accessible via the BACview⁶ Handheld tool, i-Vu Open, or Field Assistant control system. The daily schedule consists of a start/stop time (standard or 24-hour mode) and seven days of the week, starting with Monday and ending on Sunday. To enter a daily schedule, navigate to Config, then Sched, then enter BACview⁶ Admin Password (1111), then go to schedule_schedule. From here, enter either a Weekly or Exception schedule for the unit.

Occupancy Input Contact — The WSHP Open controller has the capability to use an external dry contact closure to determine the occupancy status of the unit. The Occupancy Schedules will need to be disabled in order to utilize the occupancy contact input.

NOTE: Scheduling can only be controlled from one source.

BAS (Building Automation System) On/Off — A BAS system that supports network scheduling can control the unit through a network communication and the BAS scheduling function once the Occupancy Schedules have been disabled.

NOTE: Scheduling can either be controlled via the unit or the BAS, but not both.

INDOOR FAN — The indoor fan will operate in any one of three modes depending on the user configuration selected.

Fan mode can be selected as Auto, Continuous, or Always On. In Auto mode, the fan is in intermittent operation during both occupied and unoccupied periods. Continuous fan mode is intermittent during unoccupied periods and continuous during occupied periods. Always On mode operates the fan continuously during both occupied and unoccupied periods. In the default mode, Continuous, the fan will be turned on whenever any one of the following is true:

- The unit is in occupied mode as determined by its occupancy status.
- There is a demand for cooling or heating in the unoccupied mode.
- There is a call for dehumidification (optional).

When power is reapplied after a power outage, there will be a configured time delay of 5 to 600 seconds before starting the fan. There are also configured fan delays for Fan On and Fan Off. The Fan On delay defines the delay time (0 to 30 seconds; default 10) before the fan begins to operate after heating or cooling is started while the Fan Off delay defines the delay time (0 to 180 seconds; default 45) the fan will continue to operate after heating or cooling is stopped. The fan will continue to run as long as the compressors, heating stages, or the dehumidification relays are on. If the SPT failure alarm or condensate overflow alarm is active, the fan will be shut down immediately regardless of occupancy state or demand.

Automatic Fan Speed Control — The WSHP Open controller is capable of controlling up to three fan speeds using the ECM (electronically commutated motor). The motor will operate at the lowest speed possible to provide quiet and efficient fan operation with the best latent capability. The motor will increase speed if additional cooling or heating is required to obtain the desired space temperature set point. The control increases the motor's speed as the space temperature rises above the cooling or below the heating set point. The amount of space temperature increase above or below the set point required to increase the fan speed is user configurable in the set point. Also, the control will increase the fan speed as the supply-air temperature approaches the configured minimum or maximum limits.

Fan Speed Control (During Heating) — Whenever heat is required and active, the control continuously monitors the supply-air temperature to verify it does not rise above the configured maximum heating SAT limit (110 F default). As the SAT approaches this value, the control will increase the fan speed as required to ensure the SAT will remain within the limit. This feature provides the most quiet and efficient operation by operating the fan at the lowest speed possible.

Fan Speed Control (During Cooling) — Whenever mechanical cooling is required and active, the control continuously monitors the supply-air temperature to verify it does not fall below the configured minimum cooling SAT limit (50 F default). As the SAT approaches this value, the control will increase the fan speed as required to ensure the SAT will remain within the limit. The fan will operate at lowest speed to maximize latent capacity during cooling.

COOLING — The WSHP Open controller will operate one or two stages of compression to maintain the desired cooling set point. The compressor outputs are controlled by the PI (proportional-integral) cooling loop and cooling stages capacity algorithm. They will be used to calculate the desired number of stages needed to satisfy the space by comparing the space temperature (SPT) to the appropriate cooling set point. The water side economizer, if applicable, will be used for first stage cooling in addition to the compressor(s). The following conditions must be true in order for the cooling algorithm to run:

- Cooling is set to Enable.

- Heating mode is not active and the compressor time guard has expired.
- Condensate overflow input is normal.
- If occupied, the SPT is greater than the occupied cooling set point.
- Space temperature reading is valid.
- If unoccupied, the SPT is greater than the unoccupied cooling set point.
- If economizer cooling is available and active and the economizer alone is insufficient to provide enough cooling.
- OAT (if available) is greater than the cooling lockout temperature.

If all the above conditions are met, the compressors will be energized as required, otherwise they will be deenergized. If cooling is active and should the SAT approach the minimum SAT limit, the fan will be indexed to the next higher speed. Should this be insufficient and if the SAT falls further (equal to the minimum SAT limit), the fan will be indexed to the maximum speed. If the SAT continues to fall 5 °C below the minimum SAT limit, all cooling stages will be disabled.

During Cooling mode, the reversing valve output will be held in the cooling position (either B or O type as configured) even after the compressor is stopped. The valve will not switch position until the Heating mode is required.

The configuration screens contain the minimum SAT parameter as well as cooling lockout based on outdoor-air temperature (OAT) Both can be adjusted to meet various specifications.

There is a 5-minute off time for the compressor as well as a 5-minute time delay when staging up to allow the SAT to achieve a stable temperature before energizing a second stage of capacity. Likewise, a 45-second delay is used when staging down.

After a compressor is staged off, it may be restarted again after a normal time-guard period of 5 minutes and if the supply-air temperature has increased above the minimum supply-air temperature limit.

The WSHP Open controller provides a status input to monitor the compressor operation. The status is monitored to determine if the compressor status matches the commanded state. This input is used to determine if a refrigerant safety switch or other safety device has tripped and caused the compressor to stop operating normally. If this should occur, an alarm will be generated to indicate the faulted compressor condition.

HEATING — The WSHP Open controller will operate one or two stages of compression to maintain the desired heating set point. The compressor outputs are controlled by the heating PI (proportional-integral) loop and heating stages capacity algorithm. They will be used to calculate the desired number of stages needed to satisfy the space by comparing the space temperature (SPT) to the appropriate heating set point. The following conditions must be true in order for the heating algorithm to run:

- Heating is set to Enable.
- Cooling mode is not active and the compressor time guard has expired.
- Condensate overflow input is normal.
- If occupied, the SPT is less than the occupied heating set point.
- Space temperature reading is valid.
- If unoccupied, the SPT is less than the unoccupied heating set point.
- OAT (if available) is less than the heating lockout temperature.

If all the above conditions are met, the heating outputs will be energized as required, otherwise they will be deenergized. If the heating is active and should the SAT approach the maximum SAT limit, the fan will be indexed to the next higher

speed. Should this be insufficient, and the SAT rises further reaching the maximum heating SAT limit, the fan will be indexed to the maximum speed. If the SAT still continues to rise 5° F above the maximum limit, all heating stages will be disabled.

During Heating mode, the reversing valve output will be held in the heating position (either B or O type as configured) even after the compressor is stopped. The valve will not switch position until the Cooling mode is required.

The configuration screens contain the maximum SAT parameter as well as heating lockout based on outdoor-air temperature (OAT); both can be adjusted to meet various specifications.

There is a 5-minute off time for the compressor as well as a 5-minute time delay when staging up to allow the SAT to achieve a stable temperature before energizing a second stage of capacity. Likewise, a 45-second delay is used when staging down.

After a compressor is staged off, it may be restarted again after a normal time-guard period of 5 minutes and if the supply-air temperature has fallen below the maximum supply air temperature limit.

The WSHP Open controller provides a status input to monitor the compressor operation. The status is monitored to determine if the compressor status matches the commanded state. This input is used to determine if a refrigerant safety switch or other safety device has tripped and caused the compressor to stop operating normally. If this should occur, an alarm will be generated to indicate the faulted compressor condition. Also, if auxiliary heat is available (see below), the auxiliary heat will operate to replace the reverse cycle heating and maintain the space temperature as required.

AUXILIARY HEAT — The WSHP Open controller can control a two-position, modulating water, or steam valve connected to a coil on the discharge side of the unit and supplied by a boiler or a single-stage ducted electric heater in order to maintain the desired heating set point. Should the compressor capacity be insufficient or a compressor failure occurs, the auxiliary heat will be used. Unless the compressor fails, the auxiliary heat will only operate to supplement the heat provided by the compressor if the space temperature falls more than one degree below the desired heating set point (the amount is configurable). The heat will be controlled so the SAT will not exceed the maximum heating SAT limit.

Auxiliary Modulating Hot Water/Steam Heating Reheat — The control can modulate a hot water or steam valve connected to a coil on the discharge side of the unit and supplied by a boiler in order to maintain the desired heating set point should the compressor capacity be insufficient or a compressor failure occurs. Unless a compressor fault condition exists, the valve will only operate to supplement the heat provided by the compressor if the space temperature falls more than one degree below the desired heating set point. The valve will be controlled so the SAT will not exceed the maximum heating SAT limit.

Two-Position Hot Water/Steam Heating Reheat — The control can operate a two-position, NO or NC, hot water or steam valve connected to a coil on the discharge side of the unit and supplied by a boiler in order to maintain the desired heating set point should the compressor capacity be insufficient or a compressor failure occurs. Unless a compressor fault condition exists, the valve will only open to supplement the heat provided by the compressor if the space temperature falls more than one degree below the desired heating set point. The valve will be controlled so the SAT will not exceed the maximum heating SAT limit. The heat stage will also be subject to a 2-minute minimum OFF time to prevent excessive valve cycling.

Single Stage Electric Auxiliary Heat — The control can operate a field-installed single stage of electric heat installed on

the discharge side of the unit in order to maintain the desired heating set point should the compressor capacity be insufficient or a compressor failure occurs. Unless a compressor fault condition exists, the heat stage will only operate to supplement the heat provided by the compressor if the space temperature falls more than one degree below the desired heating set point. The heat stage will be controlled so the SAT will not exceed the maximum heating SAT limit. The heat stage will also be subject to a 2-minute minimum OFF time to prevent excessive cycling.

INDOOR AIR QUALITY (IAQ) AND DEMAND CONTROLLED VENTILATION (DCV) — If the optional indoor air quality sensor is installed, the WSHP Open controller can maintain indoor air quality via a modulating OA damper providing demand controlled ventilation. The control operates the modulating OA damper during occupied periods. The control monitors the CO₂ level and compares it to the configured set points, adjusting the ventilation rate as required. The control provides proportional ventilation to meet the requirements of ASHRAE (American Society of Heating, Refrigerating and Air Conditioning Engineers) specifications by providing a base ventilation rate and then increasing the rate as the CO₂ level increases. The control will begin to proportionally increase ventilation when the CO₂ level rises above the start ventilation set point and will reach the full ventilation rate when the CO₂ level is at or above the maximum set point. A user-configurable minimum damper position ensures that proper base ventilation is delivered when occupants are not present. The IAQ configurations can be accessed through the configuration screen. The following conditions must be true in order for this algorithm to run:

- Damper control is configured for DCV.
- The unit is in an occupied mode.
- The IAQ sensor reading is greater than the DCV start control set point.

The control has four user adjustable set points: DCV start control set point, DCV maximum control set point, minimum damper position, and DCV maximum damper position.

Two-Position OA Damper — The control can be configured to operate a ventilation damper in a two-position ventilation mode to provide the minimum ventilation requirements during occupied periods.

DEHUMIDIFICATION — The WSHP Open controller will provide occupied and unoccupied dehumidification only on units that are equipped with the modulating hot water reheat (HWR) option. This function requires an accessory space relative humidity sensor. When using a relative humidity sensor to control dehumidification during occupied or unoccupied times, the dehumidification set points are used accordingly. When the indoor relative humidity becomes greater than the dehumidification set point, a dehumidification demand will be acknowledged. Once acknowledged, the dehumidification output will be energized, bringing on the supply fan (medium speed), mechanical cooling, and the integral hot water reheat coil. The controls will engage Cooling mode and waste heat from the compressor cooling cycle will be returned to the reheat coil simultaneously, meaning that the reversing valve is causing the compressor to operate in the Cooling mode. During Cooling mode, the unit cools, dehumidifies, and disables the HWR coil; however, once the call for cooling has been satisfied and there is still a call for dehumidification, the unit will continue to operate using the Reheat mode and HWR coil.

WATERSIDE ECONOMIZER — The WSHP Open controller has the capability of providing modulating or two-position water economizer operation (for a field-installed economizer coil mounted to the entering air side of the unit and connected to the condenser water loop) in order to provide free cooling (or preheating) when water conditions are optimal. Water economizer settings can be accessed through the equipment status

screen. The following conditions must be true for economizer operation:

- SAT reading is available.
- LWT reading is available.
- If occupied, the SPT is greater than the occupied cooling set point or less than the occupied heating set point and the condenser water is suitable.
- Space temperature reading is valid.
- If unoccupied, the SPT is greater than the unoccupied cooling set point or less than the unoccupied heating set point and the condenser water is suitable.

Modulating Water Economizer Control — The control has the capability to modulate a water valve to control condenser water flowing through a coil on the entering air side of the unit.

Cooling — The purpose is to provide an economizer cooling function by using the water loop when the entering water loop temperature is suitable (at least 5°C F below space temperature). If the water loop conditions are suitable, then the valve will modulate open as required to maintain a supply-air temperature that meets the load conditions. Should the economizer coil capacity alone be insufficient for a period greater than 5 minutes, or should a high humidity condition occur, then the compressor will also be started to satisfy the load. Should the SAT approach the minimum cooling SAT limit, the economizer valve will modulate closed during compressor operation.

Heating — Additionally, the control will modulate the water valve should the entering water loop temperature be suitable for heating (at least 5°C F above space temperature) and heat is required. The valve will be controlled in a similar manner except to satisfy the heating requirement. Should the economizer coil capacity alone be insufficient to satisfy the space load conditions for more than 5 minutes, then the compressor will be started to satisfy the load. Should the SAT approach the maximum heating SAT limit, the economizer valve will modulate closed during compressor operation.

Two-Position Water Economizer Control — The control has the capability to control a NO or NC, two-position water valve to control condenser water flow through a coil on the entering air side of the unit.

Cooling — The purpose is to provide a cooling economizer function directly from the condenser water loop when the entering water loop temperature is suitable (at least 5°C F below space temperature). If the optional coil is provided and the water loop conditions are suitable, then the valve will open to provide cooling to the space when required. Should the capacity be insufficient for a period greater than 5 minutes, or should a high humidity condition occur, then the compressor will be started to satisfy the load. Should the SAT reach the minimum cooling SAT limit, the economizer valve will close during compressor operation.

Heating — Additionally, the economizer control will open the water valve should the entering water loop temperature be suitable for heating (at least 5°C F above space temperature) and heat is required. The valve will be controlled in a similar manner except to satisfy the heating requirement. Should the coil capacity be insufficient to satisfy the space load for more than 5 minutes, then the compressor will be started to satisfy the load. Should the SAT reach the maximum heating SAT limit, the economizer valve will close during compressor operation.

DEMAND LIMIT — The WSHP Open controller has the ability to accept three levels of demand limit from the network. In response to a demand limit, the unit will decrease its heating set point and increase its cooling set point to widen the range in order to immediately lower the electrical demand. The amount of temperature adjustment in response is user adjustable for both heating and cooling and for each demand level. The response to a particular demand level may also be set to zero.

CONDENSER WATER LINKAGE — The control provides optimized water loop operation using an universal

controller (UC) open loop controller. Loop pump operation is automatically controlled by WSHP equipment occupancy schedules, unoccupied demand and tenant override conditions. Positive pump status feedback prevents nuisance fault trips. The condenser water linkage operates when a request for condenser water pump operation is sent from each WSHP to the loop controller. This request is generated whenever any WSHP is scheduled to be occupied, is starting during optimal start (for warm-up or pull down prior to occupancy), there is an unoccupied heating or cooling demand, or a tenant pushbutton override. At each WSHP, the water loop temperature and the loop pump status is given. The WSHP will NOT start a compressor until the loop pumps are running or will shutdown the compressors should the pumps stop. This prevents the WSHP from operating without water flow and thus tripping out on refrigerant pressure, causing a lockout condition. The WSHP Open controller control will prevent this from occurring. Also, the loop controller can be configured to start the pumps only after a configurable number of WSHPs are requesting operation (from 1-"N"). This can be used to prevent starting the entire loop operation for only one WSHP. Meanwhile, the WSHPs will not operate if the loop pump status is off and therefore the WSHP compressor will not run.

COMPLETE C AND DELUXE D BOARD SYSTEM TEST

Test mode provides the ability to check the control operation in a timely manner. The control enters a 20-minute test mode by momentarily shorting the test terminals. All time delays are sped up 15 times. The follow operations are common to both Complete C and Deluxe D controls.

Test Mode — To enter Test mode, cycle the power 3 times within 60 seconds. The LED will flash a code representing the last fault when entering the Test mode. The alarm relay will also power on and off during Test mode. See Tables 34 and 35. To exit Test mode, short the terminals for 3 seconds or cycle the power 3 times within 60 seconds.

NOTE: The flashing code and alarm relay cycling code will both have the same numerical label. For example, flashing code 1 will have an alarm relay cycling code 1. Code 1 indicates the control has not faulted since the last power off to power on sequence.

Table 34 — Complete C Control Current LED Status and Alarm Relay Operations

LED STATUS	DESCRIPTION OF OPERATION	ALARM RELAY
On	Normal Mode	Open
	Normal Mode with PM Warning	Cycle (closed 5 sec., open 25 sec.)
Off	Complete C Control is non-functional	Open
Slow Flash	Fault Retry	Open
Fast Flash	Lockout	Closed
Slow Flash	Over/Under Voltage Shutdown	Open, (Closed after 15 minutes)
Flashing Code 1	Test Mode — No fault in memory	Cycling Code 1
Flashing Code 2	Test Mode — HP Fault in memory	Cycling Code 2
Flashing Code 3	Test Mode — LP Fault in memory	Cycling Code 3
Flashing Code 4	Test Mode — FP1 Fault in memory	Cycling Code 4
Flashing Code 5	Test Mode — FP2 Fault in memory	Cycling Code 5
Flashing Code 6	Test Mode — CO Fault in memory	Cycling Code 6
Flashing Code 7	Test Mode — Over/Under shutdown in memory	Cycling Code 7
Flashing Code 8	Test Mode — PM in memory	Cycling Code 8
Flashing Code 9	Test Mode — FP1/FP2 Swapped Fault in memory	Cycling Code 9

LEGEND

- | | | | |
|----|-----------------------|-----|------------------------|
| CO | — Condensate Overflow | LED | — Light-Emitting Diode |
| FP | — Freeze Protection | LP | — Low Pressure |
| HP | — High Pressure | PM | — Performance Monitor |

NOTES:

1. Slow flash is 1 flash every 2 seconds.
2. Fast flash is 2 flashes every 1 second.
3. EXAMPLE: "Flashing Code 2" is represented by 2 fast flashes followed by a 10-second pause. This sequence will repeat continually until the fault is cleared.

Table 35 — Complete C Control LED Code and Fault Descriptions

LED CODE	FAULT	DESCRIPTION
1	No fault in memory	There has been no fault since the last power-down to power-up sequence
2	High-Pressure Switch	HP switch opens instantly
3	Low-Pressure Switch	LP switch opens for 30 continuous seconds before or during a call (bypassed for first 60 seconds)
4	Freeze Protection Coax — FP1	FP1 below Temp limit for 30 continuous seconds (bypassed for first 60 seconds of operation)
5	Freeze Protection Air Coil — FP2	FP2 below Temp limit for 30 continuous seconds (bypassed for first 60 seconds of operation)
6	Condensate overflow	Sense overflow (grounded) for 30 continuous seconds
7 (Autoreset)	Over/Under Voltage Shutdown	"R" power supply is <19VAC or >30VAC
8	PM Warning	Performance Monitor Warning has occurred.
9	FP1 and FP2 Thermistors are swapped	FP1 temperature is higher than FP2 in heating/test mode, or FP2 temperature is higher than FP1 in cooling/test mode.

LEGEND

FP — Freeze Protection LP — Low Pressure
 HP — High Pressure PM — Performance Monitor
 LED — Light-Emitting Diode

WSHP Open Test Mode — To enter WSHP Open test mode, navigate from the BACview⁶ home screen to the configuration screen. Choose the service screen and enable unit test. The controller will then test the following:

FAN TEST — Tests all fan speeds, sequences fan from low to high, and operates each speed for one minute. Resets to disable on completion.

COMPRESSOR TEST — Tests compressor cooling and heating operation. Sequences cooling stage 1 then cooling stage 2 followed by heating stage 2 then reduces capacity to heating stage 1. Operates for 1 minute per step.

DEHUMIDIFICATION TEST — Tests dehumidification mode. Operates for 2 minutes.

AUXILIARY HEATING TEST — Tests auxiliary heat. Sequences fan on and enables heating coil for 1 minute.

H₂O ECONOMIZER TEST — Tests entering/returning water loop economizer operation. Sequences fan and opens economizer water valve for one minute.

OPEN VENT DAMPER 100% TEST — Tests outside air (OA) damper operation.

PREPOSITION OA DAMPER — Prepositions OA damper actuator to set proper preload.

NOTE: The auxiliary heating test, H₂O economizer test, open vent damper 100% test, and preposition OA damper features will not be visible on the screen unless configured.

Once tests are complete, set unit test back to disable. Unit will automatically reset to disable after 1 hour.

Retry Mode — In Retry mode, the status LED will start to flash slowly to signal that the control is trying to recover from an input fault. The control will stage off the outputs and try to again satisfy the thermostat used to terminal Y. Once the thermostat input calls are satisfied, the control will continue normal operation.

NOTE: If 3 consecutive faults occur without satisfying the thermostat input call to terminal Y, the control will go into lockout mode. The last fault causing the lockout is stored in memory and can be viewed by entering Test mode.

Aquazone™ Deluxe D Control LED Indicators — There are 3 LED indicators on the Deluxe D control:

STATUS LED — Status LED indicates the current status or mode of the D control. The Status LED light is green.

TEST LED — Test LED will be activated any time the D control is in test mode. The Test LED light is yellow.

FAULT LED — Fault LED light is red. The fault LED will always flash a code representing the last fault in memory. If there is no fault in memory, the fault LED will flash code 1 and appear as one fast flash alternating with a 10-second pause. See Table 36.

Table 36 — Aquazone™ Deluxe D Control Current LED Status and Alarm Relay Operations

DESCRIPTION	STATUS LED (Green)	TEST LED (Yellow)	FAULT LED (Red)	ALARM RELAY
Normal Mode	On	Off	Flash Last Fault Code in Memory	Open
Normal Mode with PM	On	Off	Flashing Code 8	Cycle (closed 5 sec, open 25 sec, ...)
Deluxe D Control is non-functional	Off	Off	Off	Open
Test Mode	—	On	Flash Last Fault Code in Memory	Cycling Appropriate Code
Night Setback	Flashing Code 2	—	Flash Last Fault Code in Memory	—
ESD	Flashing Code 3	—	Flash Last Fault Code in Memory	—
Invalid T-stat Inputs	Flashing Code 4	—	Flash Last Fault Code in Memory	—
No Fault in Memory	On	Off	Flashing Code 1	Open
HP Fault	Slow Flash	Off	Flashing Code 2	Open
LP Fault	Slow Flash	Off	Flashing Code 3	Open
FP1 Fault	Slow Flash	Off	Flashing Code 4	Open
FP2 Fault	Slow Flash	Off	Flashing Code 5	Open
CO Fault	Slow Flash	Off	Flashing Code 6	Open
Over/Under Voltage	Slow Flash	Off	Flashing Code 7	Open (closed after 15 minutes)
HP Lockout	Fast Flash	Off	Flashing Code 2	Closed
LP Lockout	Fast Flash	Off	Flashing Code 3	Closed
FP1 Lockout	Fast Flash	Off	Flashing Code 4	Closed
FP2 Lockout	Fast Flash	Off	Flashing Code 5	Closed
CO Lockout	Fast Flash	Off	Flashing Code 6	Closed

LEGEND

CO — Condensate Overflow HP — High Pressure
 ESD — Emergency Shutdown LP — Low Pressure
 FP — Freeze Protection PM — Performance Monitor

NOTES:

1. If there is no fault in memory, the Fault LED will flash code 1.
2. Codes will be displayed with a 10-second Fault LED pause.
3. Slow flash is 1 flash every 2 seconds.
4. Fast flash is 2 flashes every 1 second.
5. EXAMPLE: "Flashing Code 2" is represented by 2 fast flashes followed by a 10-second pause. This sequence will repeat continually until the fault is cleared.

SERVICE

Perform the procedures outlined below periodically, as indicated.

⚠ WARNING

To prevent injury or death due to electrical shock or contact with moving parts, open unit disconnect switch before servicing unit.

IMPORTANT: When a compressor is removed from this unit, system refrigerant circuit oil will remain in the compressor. To avoid leakage of compressor oil, the refrigerant lines of the compressor must be sealed after it is removed.

IMPORTANT: All refrigerant discharged from this unit must be recovered without exception. Technicians must follow industry accepted guidelines and all local, state and federal statutes for the recovery and disposal of refrigerants.

IMPORTANT: To avoid the release of refrigerant into the atmosphere, the refrigerant circuit of this unit must only be serviced by technicians who meet local, state and federal proficiency requirements.

Filters — Filters must be clean for maximum performance. Inspect filters every month under normal operating conditions. Replace when necessary.

IMPORTANT: Units should never be operated without a filter.

Water Coil — Keep all air out of the water coil. Check open loop systems to be sure the well head is not allowing air to infiltrate the water line. Always keep lines airtight.

Inspect heat exchangers regularly, and clean more frequently if the unit is located in a “dirty” environment. Keep the heat exchanger full of water at all times. Open loop systems should have an inverted P trap placed in the discharge line to keep water in the heat exchanger during off cycles. Closed loop systems must have a minimum of 15 psig during the summer and 40 psig during the winter.

Check P trap frequently for proper operation.

⚠ CAUTION

To avoid fouled machinery and extensive unit clean-up, DO NOT operate units without filters in place. DO NOT use equipment as a temporary heat source during construction.

Condensate Drain Pans — Check condensate drain pans for algae growth twice a year. If algae growth is apparent, consult a water treatment specialist for proper chemical treatment. Applying an algacide every three months will typically eliminate algae problems in most locations.

Refrigerant System — Verify air and water flow rates are at proper levels before servicing. To maintain sealed circuitry integrity, do not install service gages unless unit operation appears abnormal.

Check to see that unit is within the superheat and subcooling temperature ranges shown in Tables 20-30. If the unit is not within these ranges, recover and reweigh in refrigerant charge.

Compressor — Conduct annual amperage checks to ensure that amp draw is no more than 10% greater than indicated on the serial plate data.

Fan Motors — All units have lubricated fan motors. Fan motors should never be lubricated unless obvious, dry operation is suspected. Periodic maintenance oiling is NOT recommended as it will result in dirt accumulating in the excess oil and cause eventual motor failure. Conduct annual dry operation check and amperage check to ensure amp draw is no more than 10% greater than indicated on serial plate data.

Condensate Drain Cleaning — Clean the drain line and unit drain pan at the start of each cooling season. Check flow by pouring water into drain. Be sure trap is filled to maintain an air seal.

Air Coil Cleaning — Remove dirt and debris from evaporator coil as required by condition of the coil. Clean coil with a stiff brush, vacuum cleaner, or compressed air. Use a fin comb of the correct tooth spacing when straightening mashed or bent coil fins.

Condenser Cleaning — Water-cooled condensers may require cleaning of scale (water deposits) due to improperly maintained closed-loop water systems. Sludge build-up may need to be cleaned in an open water tower system due to induced contaminants.

Local water conditions may cause excessive fouling or pitting of tubes. Condenser tubes should therefore be cleaned at least once a year, or more often if the water is contaminated.

Proper water treatment can minimize tube fouling and pitting. If such conditions are anticipated, water treatment analysis is recommended. Refer to the Carrier System Design Manual, Part 5, for general water conditioning information.

⚠ CAUTION

Follow all safety codes. Wear safety glasses and rubber gloves when using inhibited hydrochloric acid solution. Observe and follow acid manufacturer’s instructions.

Clean condensers with an inhibited hydrochloric acid solution. The acid can stain hands and clothing, damage concrete, and, without inhibitor, damage steel. Cover surroundings to guard against splashing. Vapors from vent pipe are not harmful, but take care to prevent liquid from being carried over by the gases.

Warm solution acts faster, but cold solution is just as effective if applied for a longer period.

GRAVITY FLOW METHOD — Do not add solution faster than vent can exhaust the generated gases.

When condenser is full, allow solution to remain overnight, then drain condenser and flush with clean water. Follow acid manufacturer’s instructions. See Fig. 36.

FORCED CIRCULATION METHOD — Fully open vent pipe when filling condenser. The vent may be closed when condenser is full and pump is operating. See Fig. 37.

Regulate flow to condenser with a supply line valve. If pump is a non overloading type, the valve may be fully closed while pump is running.

For average scale deposit, allow solution to remain in condenser overnight. For heavy scale deposit, allow 24 hours. Drain condenser and flush with clean water. Follow acid manufacturer’s instructions.

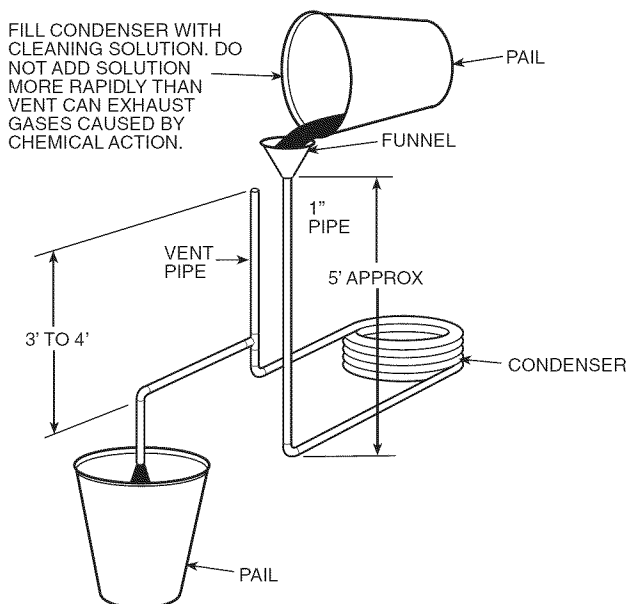

Fig. 36 — Gravity Flow Method

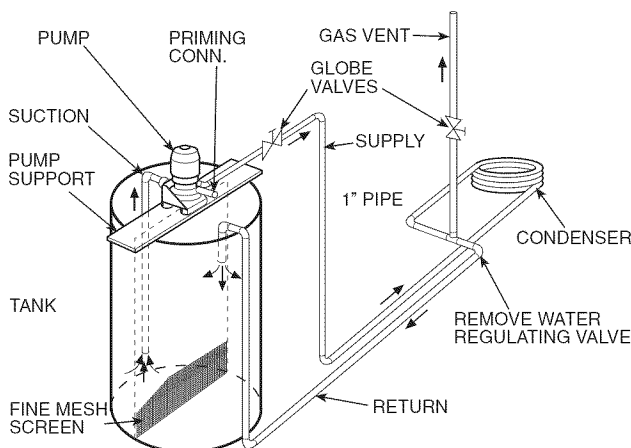

Fig. 37 — Forced Circulation Method

Checking System Charge — Units are shipped with full operating charge. If recharging is necessary:

1. Insert thermometer bulb in insulating rubber sleeve on liquid line near filter drier. Use a digital thermometer for all temperature measurements. DO NOT use a mercury or dial-type thermometer.
2. Connect pressure gage to discharge line near compressor.
3. After unit conditions have stabilized, read head pressure on discharge line gage.

NOTE: Operate unit a minimum of 15 minutes before checking charge.

4. From standard field-supplied Pressure-Temperature chart for R-410A, find equivalent saturated condensing temperature.
5. Read liquid line temperature on thermometer; then subtract from saturated condensing temperature. The difference equals subcooling temperature.

6. Compare the subcooling temperature with the normal temperature listed in Tables 20-30. If the measured liquid line temperature does not agree with the required liquid line temperature, ADD refrigerant to raise the temperature or REMOVE refrigerant (using standard practices) to lower the temperature (allow a tolerance of $\pm 3^\circ \text{F}$).

Refrigerant Charging

⚠ WARNING

To prevent personal injury, wear safety glasses and gloves when handling refrigerant. Do not overcharge system — this can cause compressor flooding.

NOTE: Do not vent or depressurize unit refrigerant to atmosphere. Remove and recover refrigerant following accepted practices.

Air Coil Fan Motor Removal

⚠ CAUTION

Before attempting to remove fan motors or motor mounts, place a piece of plywood over evaporator coils to prevent coil damage.

Disconnect motor power wires from motor terminals before motor is removed from unit.

1. Shut off unit main power supply.
2. Loosen bolts on mounting bracket so that fan belt can be removed.
3. Loosen and remove the 2 motor mounting bracket bolts on left side of bracket.

Slide motor/bracket assembly to extreme right and lift out through space between fan scroll and side frame. Rest motor on a high platform such as a step ladder. Do not allow motor to hang by its power wires.

Replacing the WSHP Open Controller's Battery

— The WSHP Open controller's 10-year lithium CR2032 battery provides a minimum of 10,000 hours of data retention during power outages.

NOTE: Power must be ON to the WSHP Open controller when replacing the battery, or the date, time and trend data will be lost.

1. Remove the battery from the controller, making note of the battery's polarity.
2. Insert the new battery, matching the battery's polarity with the polarity indicated on the WSHP Open controller.

TROUBLESHOOTING

When troubleshooting problems with a WSHP, consider the following:

Control Sensors — The control system employs 2 nominal 10,000 ohm thermistors (FP1 and FP2) that are used for freeze protection. Be sure FP1 is located in the discharge fluid and FP2 is located in the air discharge. See Fig. 38.

Thermistor — A thermistor may be required for single-phase units where starting the unit is a problem due to low voltage. See Fig. 39 for thermistor nominal resistance.

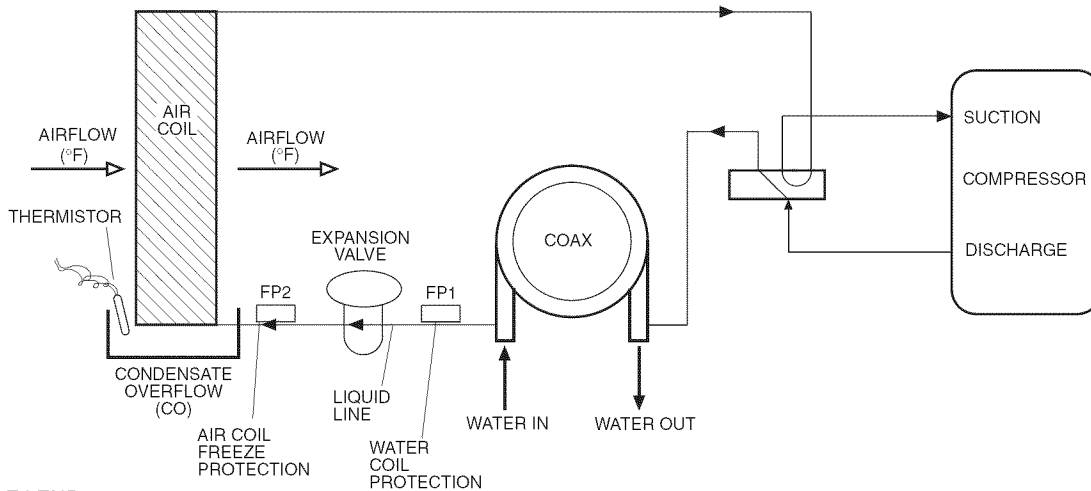

LEGEND
COAX — Coaxial Heat Exchanger
 Airflow
 Refrigerant Liquid Line Flow

Fig. 38 — FP1 and FP2 Thermistor Location

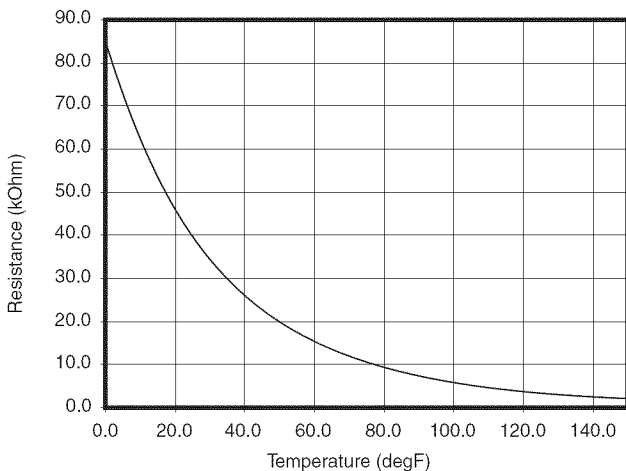

Fig. 39 — Thermistor Nominal Resistance

WSHP Open Controller — With the WSHP Open controller option, the 100 most recent alarms can be viewed using the BACview⁶ alarm status and alarm history.

To view the alarms:

1. Navigate to the Alarm Status screen from the Home screen using the arrow softkeys. The screen will display the current alarm status, either normal or Alarm, and allow for scrolling through the unit's alarm status.
2. From the Alarm Status screen, press the Alarm softkey to view the 100 most recent alarms which are labeled with date and time for easy reference.

NOTE: Active faults can be viewed by scrolling down, these faults indicate a possible bad sensor or some condition which may not merit an alarm.

3. To view alarms which have been corrected, scroll down through the Alarm screen to Return Top Normal screen.

NOTE: Alarms are automatically reset once alarm condition has been corrected.

See Table 37 for possible alarm cause and solution.

Thermostatic Expansion Valves — Thermostatic expansion valves (TXV) are used as a means of metering the refrigerant through the evaporator to achieve a preset superheat

at the TXV sensing bulb. Correct superheat of the refrigerant is important for the most efficient operation of the unit and for the life of the compressor.

Packaged heat pumps typically use one bi-flow TXV to meter refrigerant in both modes of operation. When diagnosing possible TXV problems it may be helpful to reverse the refrigerant flow to assist with the diagnosis.

Geothermal and water source heat pumps are designed to operate through a wide range of entering water temperatures that will have a direct effect on the unit refrigerant operating pressures. Therefore, diagnosing TXV problems can be difficult.

TXV FAILURE — The most common failure mode of a TXV is when the valve fails while closed. Typically, a TXV uses spring pressure to close the valve and an opposing pressure, usually from a diaphragm, to open the valve. The amount of pressure exerted by the diaphragm will vary, depending on the pressure inside of the sensing bulb. As the temperature of and pressure within the bulb decreases, the valve will modulate closed and restrict the refrigerant flow through the valve. The result is less refrigerant in the evaporator and an increase in the superheat. As the temperature at the bulb increases the diaphragm pressure will increase, which opens the valve and allows more refrigerant flow and a reduction in the superheat.

If the sensing bulb, connecting capillary, or diaphragm assembly are damaged, pressure is lost and the spring will force the valve to a closed position. Often, the TXV will not close completely so some refrigerant flow will remain, even if inadequate flow for the heat pump to operate.

The TXV sensing bulb must be properly located, secured, and insulated as it will attempt to control the temperature of the line to which it is connected. The sensing bulb must be located on a dedicated suction line close to the compressor. On a packaged heat pump, the bulb may be located almost any place on the tube running from the compressor suction inlet to the reversing valve. If the bulb is located on a horizontal section, it should be placed in the 10:00 or 2:00 position for optimal performance.

CAUTION

Use caution when tightening the strap. The strap must be tight enough to hold the bulb securely but caution must be taken not to over-tighten the strap, which could dent, bend, collapse or otherwise damage the bulb.

The bulb must be secured to the pipe using a copper strap. The use of heat transfer paste between the bulb and the pipe will also help ensure optimum performance.

The bulb must also be properly insulated to eliminate any influence on valve operation by the surrounding conditions. Cork tape is the recommended insulation as it can be molded tight to the bulb to prevent air infiltration.

Causes of TXV Failure — The most common causes of TXV failure are:

1. A cracked, broken, or damaged sensing bulb or capillary can be caused by excessive vibration of the capillary during shipping or unit operation.

If the sensing bulb is damaged or if the capillary is cracked or broken, the valve will be considered failed and must be replaced. Replacement of the TXV “power head” or sensing bulb, capillary, diaphragm assembly is possible on some TXVs. The power head assembly screws onto most valves, but not all are intended to be replaceable. If the assembly is not replaceable, replace the entire valve.

2. Particulate debris within the system can be caused by several sources including contaminated components, tubing, and service tools, or improper techniques used during brazing operations and component replacement.

Problems associated with particulate debris can be compounded by refrigerant systems that use POE (polyol ester oil). POE oil has solvent-like properties that will clean the interior surfaces of tubing and components. Particulates can be released from interior surfaces and may migrate to the TXV strainer, which can lead to plugging of the strainer.

3. Corrosive debris within the system may happen after a failure, such as a compressor burn out, if system was not properly cleaned.
4. Noncondensables may be present in the system. Noncondensables includes any substance other than the refrigerant or oil such as air, nitrogen, or water. Contamination can be the result of improper service techniques, use of contaminated components, and/or improper evacuation of the system.

Symptoms — The symptoms of a failed TXV can be varied and will include one or more of the following:

- Low refrigerant suction pressure
- High refrigerant superheat
- High refrigerant subcooling
- TXV and/or low pressure tubing frosting
- Equalizer line condensing and at a lower temperature than the suction line or the equalizer line frosting
- FP1 faults in the heating mode in combination with any of the symptoms listed above
- FP2 faults in the cooling mode in combination with any of the symptoms listed above. Some symptoms can mimic a failed TXV but may actually be caused by another problem.

Before conducting an analysis for a failed TXV the following must be verified:

- Confirm that there is proper water flow and water temperature in the heating mode.
- Confirm that there is proper airflow and temperature in the cooling mode.
- Ensure coaxial water coil is clean on the inside; this applies to the heating mode and may require a scale check.
- Refrigerant may be undercharged. To verify, subcooling and superheat calculations may be required.

Diagnostics—Several tests may be required to determine if a TXV has failed. The following tools may be required for testing:

1. Refrigerant gage manifold compatible with the refrigerant in the system
2. Digital thermometer, preferably insulated, with wire leads that can be connected directly to the tubing
3. Refrigerant pressure-temperature chart for the refrigerant used

To determine that a TXV has failed, verify the following:

- The suction pressure is low and the valve is non-responsive. The TXV sensing bulb can be removed from the suction line and warmed by holding the bulb in your hand. This action should result in an increase in the suction pressure while the compressor is operating. The sensing bulb can also be chilled by immersion in ice water, which should result in a decrease in the suction pressure while the compressor is operating. No change in the suction pressure would indicate a nonresponsive valve.
- Simultaneous LOW suction pressure, HIGH refrigerant subcooling and HIGH superheat may indicate a failed valve.
- LOW suction pressure, LOW subcooling and HIGH superheat may indicate an undercharge of refrigerant. HIGH subcooling and LOW superheat may indicate an overcharge of refrigerant. The suction pressure will usually be normal or high if there is an overcharge of refrigerant.
- LOW suction pressure and frosting of the valve and/or equalizer line may indicate a failed valve. However, these symptoms may also indicate an undercharge of refrigerant. Calculate the subcooling and superheat to verify a failed valve or refrigerant charge issue.

Repair

WARNING

Puron® refrigerant (R-410A) operates at higher pressure than R-22, which is found in other WSHPs. Tools such as manifold gages must be rated to withstand the higher pressures. Failure to use approved tools may result in a failure of tools, which can lead to severe damage to the unit, injury or death.

WARNING

Most TXVs are designed for a fixed superheat setting and are therefore considered non-adjustable. Removal of the bottom cap will not provide access for adjustment and can lead to damage to the valve or equipment, unintended venting of refrigerant, personal injury, or possibly death.

CAUTION

Use caution when tightening the strap. The strap must be tight enough to hold the bulb securely but caution must be taken not to over-tighten the strap, which could dent, bend, collapse or otherwise damage the bulb.

CAUTION

Puron refrigerant (R-410A) requires the use of synthetic lubricant (POE oil). Do not use common tools on systems that contain R-22 refrigerants or mineral oil. Contamination and failure of this equipment may result.

IMPORTANT: Always recover the refrigerant from the system with suitable approved tools, recovery equipment, and practices prior to attempting to remove or repair any TXV.

IMPORTANT: Due to the hygroscopic nature of the POE oil in Puron refrigerant (R-410A) and other environmentally sound refrigerants, any component replacement must be conducted in a timely manner using caution and proper service procedure for these types of refrigerants. A complete installation instruction will be included with each replacement TXV/filter drier assembly. It is of critical importance these instructions are carefully understood and followed. Failure to follow these instructions can result in a system that is contaminated with moisture to the extent that several filter drier replacements may be required to properly dry the system.

IMPORTANT: Repair of any sealed refrigerant system requires training in the use of refrigeration tools and procedures. Repair should only be attempted by a qualified service technician. A universal refrigerant handling certificate will be required. Local and/or state license or certificate may also be required.

See Tables 37-39 for additional troubleshooting information.

⚠ CAUTION

Disconnect power from unit before removing or replacing connectors, or servicing motor. Wait 5 minutes after disconnecting power before opening motor.

Table 37 — ECM Troubleshooting

FAULT	DESCRIPTION	SOLUTION
Motor rocks slightly when starting		This is normal start-up for ECM.
Motor will not start	No movement	Check power at motor.
		Check low voltage (24-vac R to C) at motor.
		Check low voltage connections (G, Y, W, R, C) at motor.
		Check for unseated pins in connectors on motor harness. See Fig. 40.
		Test with a temporary jumper between R and G.
		Check motor for tight shaft.
		Perform motor/control replacement check.
	Run moisture check. See Moisture Check section in Troubleshooting.	
Motor rocks	Check for loose or non-compliant motor mount.	
	Make sure blower wheel is tight on shaft.	
	Perform motor/control replacement check.	
Motor oscillates up and down while being tested off of blower		It is normal for motor to oscillate with no load on shaft.
Motor starts, but runs erratically	Varies up and down or intermittent	Check line voltage for variation or "sag."
		Check low voltage connections (G, Y, W, R, C) at motor, unseated pins in motor harness connectors. See Fig. 40.
		Check "Bk" for erratic cfm command (in variable speed applications).
		Check system controls, thermostat.
		Perform moisture check. See Moisture Check section in Troubleshooting.
	"Hunts" or "puffs" at high cfm (speed)	If removing panel or filter reduces "puffing," reduce restriction or reduce maximum airflow.
	Stays at low cfm despite system call for cool or heat cfm	Check low voltage (thermostat) wires and connections.
		Verify fan is not in delay mode. Wait until delay is complete.
		Check to see if "R" is missing/not connected at motor.
	Stays at high cfm	Perform motor/control replacement check.
Check to see if "R" is missing/not connected at motor.		
Blower will not shut off	Verify fan is not in delay mode. Wait until delay is complete.	
	Perform motor/control replacement check.	
Excessive noise	Noisy blower or cabinet	Check to see if there is current leakage from controls into G, Y, or W. Check for Triac switched thermostat or solid state relay.
		Determine if it is air, cabinet, duct, or motor noise.
		Check for loose blower housing, panels, etc.
	If high static is creating high blower speed, check for air whistling through seams in ducts, cabinets, or panels.	
If high static is creating high blower speed, check for cabinet/duct deformation.		
"Hunts" or "puffs" at high cfm (speed)	If removing panel or filter reduces "puffing," reduce restriction or reduce maximum airflow.	
Evidence of moisture	Motor failure or malfunction has occurred and moisture is present	Replace motor and perform moisture check. See Moisture Check section in Troubleshooting.
	Evidence of moisture present inside air mover	Perform moisture check. See Moisture Check section in Troubleshooting.

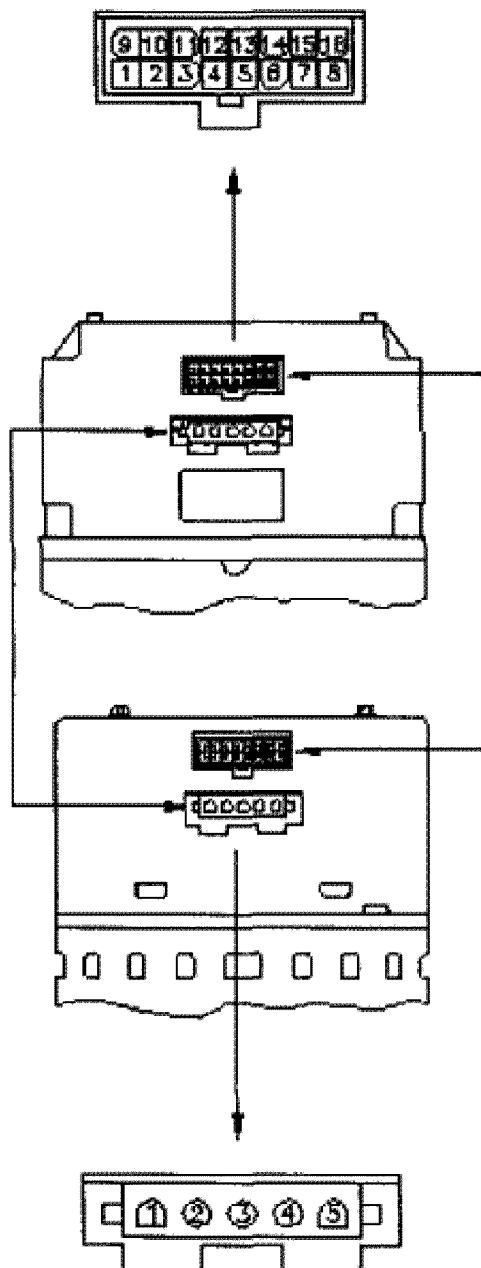

CONTROL CONNECTOR ***	
PWB HEADER AMP 770974-1	
PIN	DESCRIPTION
1	C1
2	W/W1
3	C2
4	DELAY
5	COOL
6	Y1
7	ADJUST
8	OUT-
9	D
10	BK/PWM
11	HEAT
12	R
13	EM/W2
14	Y/Y2
15	G
16	OUT+

*** SUGGESTED MATING CONNECTOR
 HOUSING - AMP 770583-1
 CONTACT - AMP 770904-1

POWER CONNECTOR *	
PWB HEADER AMP 1-350949-0	
PIN	DESCRIPTION
1	JUMPER PIN 1 TO PIN 2 FOR
2	120VAC LINE INPUT <i>ONLY</i> **
3	CHASSIS GROUND
4	AC LINE
5	AC LINE

* SUGGESTED MATING CONNECTOR
 HOUSING - AMP 1-480763-1
 CONTACT - AMP 350537-1

**** WARNING - APPLYING 240VAC LINE INPUT WITH PIN 1 TO PIN 2 JUMPER IN PLACE WILL PERMANENTLY DAMAGE UNIT.**

Fig. 40 — ECM Pin Connectors

Stopped or Malfunctioned ECM Motor — Refer to Fig. 41 to determine the possible cause of a stopped or malfunctioned ECM motor. Follow the instructions in the boxes.

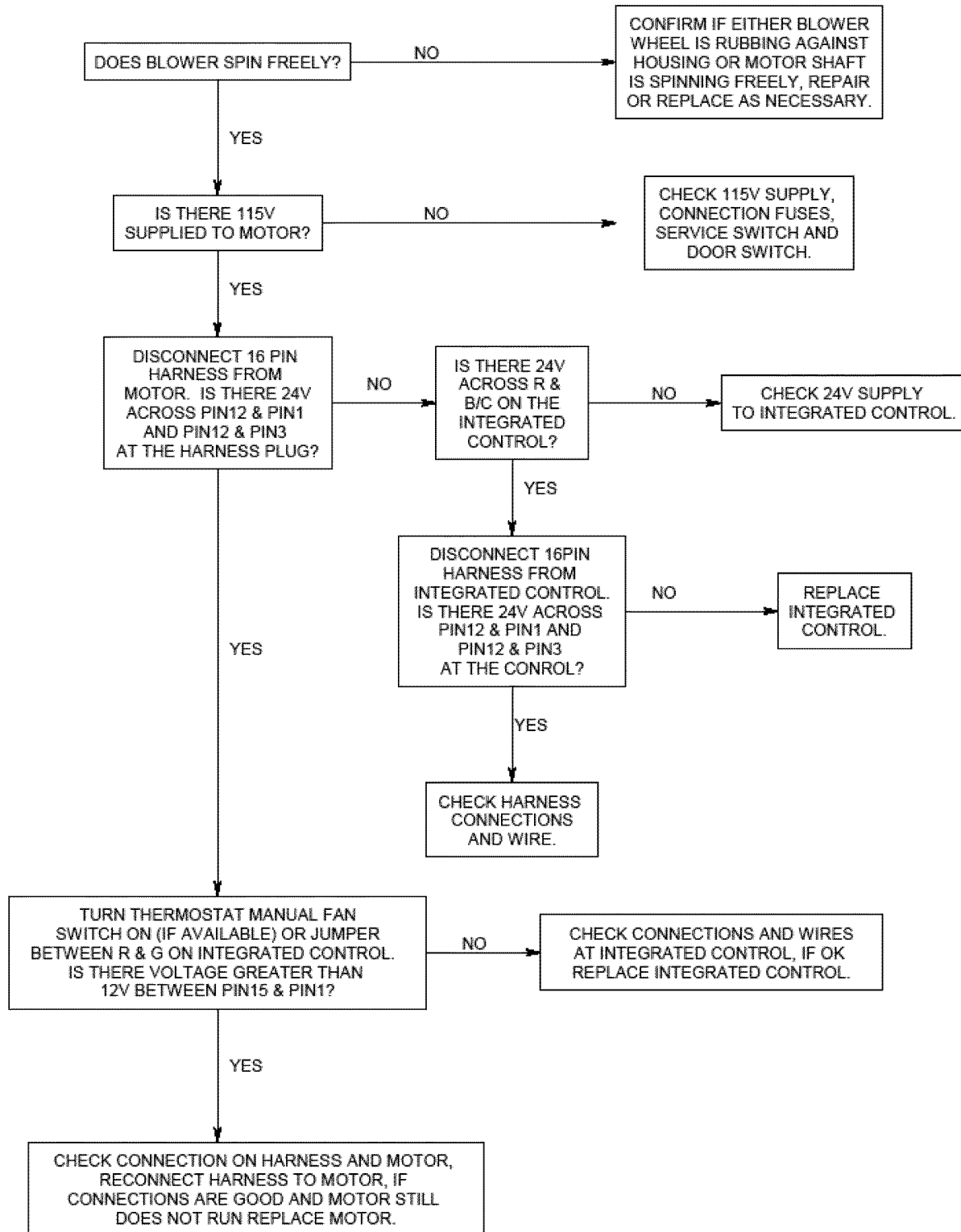

Fig. 41 — ECM Troubleshooting Flow Diagram

Moisture Check — To perform moisture check:

- Check that connectors are orientated “down” (or as recommended by equipment manufacturer).
- Arrange harnesses with “drip loop” under motor.

- Check if condensate drain is plugged.
- Check for low airflow (too much latent capacity).
- Check for undercharged condition.
- Check and plug leaks in return ducts, cabinet.

Table 38 — Good Practices

DO	DO NOT
Check motor, controls wiring, and connections thoroughly before replacing motor.	Automatically assume the motor is bad.
Orient connectors down so water cannot get in. Install “drip loops.”	Locate connectors above 7 and 4 o'clock positions.
Use authorized motor and control model numbers for replacement.	Replace one motor or control model number with another (unless replacement is authorized).
Keep static pressure to a minimum by: <ul style="list-style-type: none"> • Using high efficiency, low-static filters. • Keeping filters clean. • Designing ductwork for minimum static and maximum comfort. • Improving ductwork when replacement is necessary. 	Use high pressure drop filters. Use restricted returns.
Size equipment wisely.	Oversize system then compensate with low airflow.
Check orientation before inserting motor connectors.	Plug in power connector backwards. Force plugs.

Table 39 — WSHP Troubleshooting

FAULT	HEATING	COOLING	POSSIBLE CAUSE	SOLUTION	
Main Power Problems	X	X	Green Status LED Off	Check line voltage circuit breaker and disconnect. Check for line voltage between L1 and L2 on the contactor. Check for 24 vac between R and C on controller. Check primary/secondary voltage on transformer.	
		X	Reduced or no water flow in cooling	Check pump operation or valve operation/setting. Check water flow adjust to proper flow rate.	
		X	Water temperature out of range in cooling	Bring water temperature within design parameters.	
HP Fault — Code 2 High Pressure	X		Reduced or no airflow in heating	Check for dirty air filter and clean or replace. Check fan motor operation and airflow restrictions. Dirty air coil — construction dust etc. External static too high. Check blower performance per Tables 11-13.	
	X		Air temperature out of range in heating	Bring return-air temperature within design parameters.	
	X	X	Overcharged with refrigerant	Check superheat/subcooling vs typical operating condition per Tables 20-30.	
	X	X	Bad HP switch	Check switch continuity and operation. Replace.	
	LP/LOC Fault — Code 3 Low Pressure/Loss of Charge	X	X	Insufficient charge	Check for refrigerant leaks.
		X		Compressor pump down at start-up	Check charge and start-up water flow.
FP1 Fault — Code 4 Water Freeze Protection	X		Reduced or no water flow in heating	Check pump operation or water valve operation/setting. Plugged strainer or filter. Clean or replace. Check water flow adjust to proper flow rate.	
	X		Inadequate antifreeze level	Check antifreeze density with hydrometer.	
	X		Improper freeze protect setting (30 F vs 10 F)	Clip JW2 jumper for antifreeze (10 F) use.	
	X		Water temperature out of range	Bring water temperature within design parameters.	
	X	X	Bad thermistor	Check temperature and impedance correlation.	
FP2 Fault — Code 5 Air Coil Freeze Protection		X	Reduced or no airflow in cooling	Check for dirty air filter and clean or replace. Check fan motor operation and airflow restrictions. External static too high. Check blower performance per Tables 11-13.	
		X	Air temperature out of range	Too much cold vent air. Bring entering air temperature within design parameters.	
		X	Improper freeze protect setting (30 F vs 10 F)	Normal airside applications will require 30 F only.	
	X	X	Bad thermistor	Check temperature and impedance correlation.	

LEGEND

- LED — Light-Emitting Diode
- RV — Reversing Valve
- TXV — Thermostatic Expansion Valve

Table 39 — WSHP Troubleshooting (cont)

FAULT	HEATING	COOLING	POSSIBLE CAUSE	SOLUTION
Condensate Fault — Code 6	X	X	Blocked drain	Check for blockage and clean drain.
	X	X	Improper trap	Check trap dimensions and location ahead of vent.
		X	Poor drainage	Check for piping slope away from unit.
				Check slope of unit toward outlet.
	X	Moisture on sensor	Poor venting. Check vent location. Check for moisture shorting to air coil.	
Over/Under Voltage — Code 7 (Auto Resetting)	X	X	Under voltage	Check power supply and 24 vac voltage before and during operation.
				Check power supply wire size. Check compressor starting. Check 24 vac and unit transformer tap for correct power supply voltage.
	X	X	Over voltage	Check power supply voltage and 24 vac before and during operation. Check 24 vac and unit transformer tap for correct power supply voltage.
Performance Monitor — Code 8	X		Heating mode FP2>125 F	Check for poor airflow or overcharged unit.
		X	Cooling mode FP1>125 F OR FP2< 40 F	Check for poor water flow or airflow.
FP1 and FP2 Thermistors — Code 9	X		FP1 temperature is higher than FP2 temperature.	Swap FP1 and FP2 thermistors.
		X	FP2 temperature is higher than FP1 temperature.	Swap FP1 and FP2 thermistors.
No Fault Code Shown	X	X	No compressor operation	See Scroll Compressor Rotation section.
	X	X	Compressor overload	Check and replace if necessary.
	X	X	Control board	Reset power and check operation.
Swapped Thermistor — Code 9	X	X	FP1 and FP2 swapped	Reverse position of thermistors.
Unit Short Cycles	X	X	Dirty air filter	Check and clean air filter.
	X	X	Unit in 'Test Mode'	Reset power or wait 20 minutes for auto exit.
	X	X	Unit selection	Unit may be oversized for space. Check sizing for actual load of space.
	X	X	Compressor overload	Check and replace if necessary.
Only Fan Runs	X	X	Thermostat position	Ensure thermostat set for heating or cooling operation.
	X	X	Unit locked out	Check for lockout codes. Reset power.
	X	X	Compressor overload	Check compressor overload. Replace if necessary.
	X	X	Thermostat wiring	Check Y and W wiring at heat pump. Jumper Y and R for compressor operation in Test mode.
Only Compressor Runs	X	X	Thermostat wiring	Check G wiring at heat pump. Jumper G and R for fan operation. Check Y and W wiring at heat pump. Jumper Y and R for compressor operation in test mode.
	X	X	Fan motor relay	Jumper G and R for fan operation. Check for line voltage across BR contacts. Check fan power enable relay operation (if present).
	X	X	Fan motor	Check for line voltage at motor. Check capacitor.
Unit Does Not Operate in Cooling		X	Reversing valve	Set for cooling demand and check 24 vac on RV coil and at control. If RV is stuck, run high pressure up by reducing water flow and while operating, engage and disengage RV coil voltage to push valve.
		X	Thermostat setup	Check for 'O' RV setup not 'B'.
		X	Thermostat wiring	Check O wiring at heat pump. Jumper O and R for RV coil 'Click'.
Insufficient Capacity/ Not Cooling or Heating Properly	X	X	Dirty filter	Replace or clean.
	X		Reduced or no airflow in heating	Check for dirty air filter and clean or replace.
				Check fan motor operation and airflow restrictions. External static too high. Check blower performance per Tables 11-13.
		X	Reduced or no airflow in cooling	Check for dirty air filter and clean or replace.
				Check fan motor operation and airflow restrictions. External static too high. Check blower performance per Tables 11-13.
	X	X	Leaky ductwork	Check supply and return air temperatures at the unit and at distant duct registers if significantly different, duct leaks are present.
	X	X	Low refrigerant charge	Check superheat and subcooling per Tables 20-30.
	X	X	Restricted metering device	Check superheat and subcooling per Tables 20-30. Replace.
		X	Defective reversing valve	Set for cooling demand and check 24 vac on RV coil and at control. If RV is stuck, run high pressure up by reducing water flow and while operating, engage and disengage RV coil voltage to push valve.
	X	X	Thermostat improperly located	Check location and for air drafts behind thermostat.
X	X	Unit undersized	Recheck loads and sizing check sensible cooling load and heat pump capacity.	
X	X	Scaling in water heat exchanger	Perform condenser cleaning.	
X	X	Inlet water too hot or cold	Check load, loop sizing, loop backfill, ground moisture.	

LEGEND

- LED — Light-Emitting Diode
- RV — Reversing Valve
- TXV — Thermostatic Expansion Valve

Table 39 — WSHP Troubleshooting (cont)

FAULT	HEATING	COOLING	POSSIBLE CAUSE	SOLUTION	
High Head Pressure	X		Reduced or no airflow in heating	Check for dirty air filter and clean or replace. Check fan motor operation and airflow restrictions. External static too high. Check blower performance per Tables 11-13.	
		X	Reduced or no water flow in cooling	Check pump operation or valve operation/setting. Check water flow adjust to proper flow rate. See Tables 19 and 31.	
		X	Inlet water too hot	Check load, loop sizing, loop backfill, ground moisture. Bring return-air temperature within design parameters.	
		X	Scaling in water heat exchanger	Perform condenser cleaning.	
	X	X	Unit overcharged	Check superheat and subcooling. Reweigh in charge.	
	X	X	Noncondensables in system	Remove refrigerant, evacuate system and charge unit.	
	X	X	Restricted metering device	Check superheat and subcooling per Tables 20-30. Replace.	
	Low Suction Pressure	X		Reduced water flow in heating	Check pump operation or water valve operation/setting. Plugged strainer or filter. Clean or replace. Check water flow adjust to proper flow rate.
X			Water temperature out of range	Bring water temperature within design parameters.	
X			Reduced airflow in cooling	Check for dirty air filter and clean or replace. Check fan motor operation and airflow restrictions. External static too high. Check blower performance per Tables 11-13.	
		X	Air temperature out of range	Too much cold vent air. Bring entering air temperature within design parameters.	
X		X	Insufficient charge	Check for refrigerant leaks.	
Low Discharge Air Temperature in Heating		X		Too high airflow	Check blower performance per Tables 11-13.
	X		Poor performance	See "Insufficient Capacity."	
High Humidity		X	Too high airflow	Check blower performance per Tables 11-13.	
		X	Unit oversized	Recheck loads and sizing check sensible cooling load and heat pump capacity.	
Low Refrigerant Suction Pressure	X		Normal operation	Check/compare with Tables 20-30.	
	X		Reduced water flow	Check pump operation. Check strainer or filter. Improper flow regulator. Replace flow regulator.	
		X		Water temperature out of range	Bring water temperature within proper range.
		X		Scaling in water to refrigerant heat exchanger	Conduct water quality analysis.
		X	Reduced airflow	Check for dirty air filter. Check for dirty air coil. Check fan motor operation. External static pressure exceeds fan operating parameters.	
	X		X	Return air temperature below minimum	Space temperature too cold. Increase space temperature. Excessive fresh air. Reduce amount of fresh air exposure.
				X	Supply air bypassing to return airstream (zone systems)
	X	X	Insufficient refrigerant charge	Locate and repair leak.	
	X	X	Improperly located TXV sensing bulb	Locate bulb on suction line between reversing valve and compressor.	
	X	X	Failed or restricted metering device	Failed TXV power head, capillary or sensing bulb. Replace. Plugged TXV strainer. Unplug TXV strainer.	
				Locate and repair leak.	
	High Refrigerant Superheat	X	X	Insufficient refrigerant charge	Locate and repair leak.
		X	X	Improperly located TXV sensing bulb	Locate bulb on suction line between reversing valve and compressor.
X		X	Failed or restricted metering device	Failed TXV power head, capillary or sensing bulb. Replace. Plugged TXV strainer. Unplug TXV strainer.	
High Refrigerant Subcooling	X	X	Excessive refrigerant charge	Remove refrigerant as needed.	
	X	X	Failed or restricted metering device	Failed TXV power head, capillary or sensing bulb. Replace. Plugged TXV strainer. Unplug TXV strainer.	
TXV and/or Low Pressure Tubing Frosting	X		Normal operation	May occur when entering water temperature is close to minimum.	
	X	X	Insufficient refrigerant charge	Locate and repair leak.	
	X	X	Failed or restricted metering device	Failed TXV power head, capillary or sensing bulb. Replace. Plugged TXV strainer. Unplug TXV strainer.	
Equalizer Line Condensing or Frosting	X	X	Failed or restricted metering device	Failed TXV power head, capillary or sensing bulb. Replace. Plugged TXV strainer. Unplug TXV strainer.	

LEGEND

- LED** — Light-Emitting Diode
- RV** — Reversing Valve
- TXV** — Thermostatic Expansion Valve

APPENDIX A — WSHP OPEN SCREEN CONFIGURATION

SCREEN NAME	POINT NAME	PASSWORD LEVEL	EDITABLE	RANGE	DEFAULT	NOTES	
Equipment Status	Operating Mode	No Password Required		Off, Fan Only, Economize, Cooling, Heating, Cont Fan, Test, Start Delay, Dehumidify		Displays unit operating mode	
	SPT			° F		Displays SPT	
	SAT			° F		Displays SAT	
	Condenser Leaving Temperature			° F		Displays leaving condenser water temperature	
	Condenser Entering Temperature			° F		Displays entering condenser water temperature (Value will not update when compressor is operating)	
	Fan				Off/Low Speed/ Medium Speed/ High Speed/On		Displays fan speed status
	Compressor Capacity				0 - 100%		Displays compressor capacity
	Damper Position				0 - 100%		Displays current damper position (Viewable only if Ventilation DMP Type = 2 position or DCV)
	H ₂ O Economizer				0 - 100%		Displays position of economizer valve
	Auxiliary Heat				0 - 100%		Displays position of auxiliary reheat valve (Viewable only if Leaving Air Auxiliary Heat Type = 2 position, 1 stage Elect or Modulating)
	Space RH				0 - 100%		Displays space RH% (Viewable only if Humidity Sensor = Installed)
	Dehumidification				Inactive/Active		Displays if dehumidification is active (Viewable only if Factory Dehumidification Reheat = Installed)
	IAQ CO ₂				0 - 9999 ppm		Displays the space CO ₂ level
Alarm Status	SPT Alarm Status	No Password Required		Normal/Alarm		Displays current space temperature condition	
	Alarming SPT			° F		Displays the SPT that exceeded the alarm limit (when SPT alarm above is in Alarm)	
	SPT Alarm Limit			° F		Displays the SPT alarm limit that was exceeded; causing the alarm condition (when SPT alarm above is in Alarm)	
	SPT Sensor Alarm Status				Normal/Alarm		Displays the status of the Rnet SPT sensor - ALARM is displayed should the sensor fail to communicate with the control module
	IAQ Alarm Status				Normal/Alarm		Current IAQ/ventilation condition
	Compressor Alarm Status				Normal/Alarm		Current compressor condition
	SAT Alarm Status				Normal/Alarm		Current SAT condition
	Condensate Overflow Alarm Status				Normal/Alarm		Current status of the condensate drain (overflow switch)
	Condenser Water Temperature Alarm Status				Normal/Alarm		Current status of the condenser water
	Filter Alarm Status				Normal/Alarm		Current filter condition
	Space RH Alarm Status				Normal/Alarm		Current space RH condition
	OAT Alarm Status				Normal/Alarm		Current status of the OAT broadcast function
	Airside Linkage Status				Normal/Alarm		Current linkage status if enabled
	Condenser Water Linkage				Normal/Alarm		Current linkage status if enabled
	Sensor Calibration		SAT	Admin Password level access only		° F	
SAT Offset		X	-9.9 - 10.0 ° F		0 ° F	Used to correct sensor reading	
Leaving Condenser Water Temperature			° F			Displays Leaving Condenser Water Temperature	
Leaving CW Offset		X	-9.9 - 10.0 ° F		0 ° F	Used to correct sensor reading	
Rnet Sensor Temperature			° F			Displays SPT	
Rnet Offset		X	-9.9 - 10.0 ° F		0 ° F	Used to correct sensor reading	
RH			%			Displays Space RH value	
RH Sensor Offset		X	-15% - 15%		0 %	Used to correct sensor reading	

LEGEND

- BAS** — Building Automation System
- DCV** — Demand Controlled Ventilation
- IAQ** — Indoor Air Quality
- OAT** — Outdoor Air Temperature
- RH** — Relative Humidity
- SAT** — Supply Air Temperature
- SPT** — Space Temperature
- TPI** — Third Party Integration

APPENDIX A — WSHP OPEN SCREEN CONFIGURATION (cont)

SCREEN NAME	POINT NAME	PASSWORD LEVEL	EDITABLE	RANGE	DEFAULT	NOTES		
Unit Maintenance	Operating Mode	No Password required		Off, Fan Only, Economize, Cooling, Heating, Cont Fan, Test, Start Delay, Dehumidify		Displays unit operating mode		
	Fan Operating Mode			Auto/Continuous/Always On		Displays how the fan is configured to operate		
	Occupancy Status				Unoccupied/Occupied		Displays the current occupancy status	
	Occupancy Control				Always Occupied/Local Schedule/BACnet Schedule/BAS Keypad/ Occupied Contact/Holiday Schedule/Override Schedule/Pushbutton Override/Unoccupied None		Displays the origin of the occupancy control	
	Outside Air Temperature				° F		Displays OAT (Viewable only if OAT is a network broadcast)	
	SPT				° F		Displays SPT	
	SPT Status				Normal/Above Limit/Below Limit/Sensor Failure		Displays the SPT status	
	SPT Sensor Status				Inactive/Connected		Displays the connection status of the Rnet sensor	
	Condensate Overflow				Normal/Alarm		Displays the status of the condensate overflow	
	Cooling Set Point				° F		Displays the actual set point being used for cooling control	
	Heating Set Point				° F		Displays the actual set point being used for heating control	
	Set Point Adjustment				° F		Displays the offset values from the Rnet user set point adjustment that is being applied to the configured set points	
	Auxiliary Heat Control Set Point				° F		Displays the calculated set point being used for auxiliary heating control	
	H ₂ O Economizer Control Set Point				° F		Displays the calculated set point being used for economizer control	
	Calculated IAQ/Ventilation Damper position				%		Displays the ventilation damper position calculated by the DCV control	
	Active Compressor Stages				0/1/2		Displays the actual number of compressor stages operating	
	SAT				° F		Displays SAT	
	Reset Filter Alarm				X	No/Yes		Used to reset the filter alarm timer after the filter has been cleaned or replaced
	Overflow Contact					Closed/Open		Displays the state of the condensate overflow switch contact
	Occupancy Contact					Closed/Open		Displays the state of the external/remote occupancy input switch contact
BAS/Keypad Override			X	Inactive/Occupied/Unoccupied	Inactive	Provides capability to force the equipment to operate in an occupied or unoccupied mode		
OAT Input				N/A / Network		Displays if an OAT value is being received from the Network		
System Settings	BACnet		X			See TPI		
	Keypad Configuration		X			Mapping		
	Password		X			Changes password		
	Network		X			See TPI		
	BACnet Time Master		X			See TPI		
	Clock Set		X			Changes clock/time setting		
Occupancy Maintenance	Override Schedules	No Password required		Inactive/Active Occupied		Used to display the active and inactive occupancy control inputs		
	Pushbutton Override			Inactive/Active Occupied				
	Keypad Override			Inactive/Active Occupied/Active Unoccupied				
	Schedules			Inactive/Active Occupied				
	Occupancy Contact			Inactive/Active Occupied				
	BAS on/off			Inactive/Active Occupied				
Schedule Configuration	Local Occupancy Schedules	User/Admin Password level access	X	Disable/Enable	Enable	Used to define which occupancy inputs are used to determine occupancy mode.		
	Local Holiday Schedules		X	Disable/Enable	Disable			
	Local Override Schedules		X	Disable/Enable	Disable			
	BACnet Occupancy Schedules		X	Disable/Enable	Disable			

LEGEND

BAS	— Building Automation System
DCV	— Demand Controlled Ventilation
IAQ	— Indoor Air Quality
OAT	— Outdoor Air Temperature
RH	— Relative Humidity
SAT	— Supply Air Temperature
SPT	— Space Temperature
TPI	— Third Party Integration

APPENDIX A — WSHP OPEN SCREEN CONFIGURATION (cont)

SCREEN NAME	POINT NAME	PASSWORD LEVEL	EDITABLE	RANGE	DEFAULT	NOTES
Configuration ↓ Set Points	Occupied Heating	User/Admin Password level access	X	40 - 90 ° F	72 ° F	Defines the Occupied Heating Set Point
	Occupied Cooling		X	55 - 99 ° F	76 ° F	Defines the Occupied Cooling Set Point
	Unoccupied Heating		X	40 - 90 ° F	55 ° F	Defines the Unoccupied Heating Set Point
	Unoccupied Cooling		X	55 - 99 ° F	90 ° F	Defines the Unoccupied Cooling Set Point
	Effective Heating Set Point		X	0 - 10 ° F		Takes into effect bias (maximum allowable set point deviation)
	Effective Cooling Set Point		X	0 - 10 ° F		Takes into effect bias (maximum allowable set point deviation)
	Optimal Start					Uses historical data to calculate ramp up time so as to be at set point at occupied/unoccupied time
	Occupied RH Set Point		X	0 - 100%	65%	Defines the control set point used during occupied periods (Viewable only if Humidity Sensor = Installed/ Determines when to start Dehumidification when occupied)
	Unoccupied RH Set Point		X	0 - 100%	90%	Defines the control set point used during unoccupied periods (Viewable only if Humidity Sensor = Installed/Determines when to start Dehumidification when unoccupied)
	DCV CTRL Start Set Point		X	0 - 9999 ppm	500 ppm	Defines the control set point used to start increasing ventilation during occupied periods (Viewable only if Ventilation DMP Type = DCV)
	DCV Max CTRL Set Point		X	0 - 9999 ppm	1050 ppm	Defines the control set point used to define where the ventilation will reach its maximum limit during occupied periods (Viewable only if Ventilation DMP Type = DCV/Used to determine DCV ending control point)
Configuration ↓ Schedule ↓ Weekly Schedule	Start Time	User/Admin Password level access	X	00:00 - 23:59	06:00	Defines the start time for an occupied period
	End Time		X	00:00 - 24:00	18:00	Defines the ending time of an occupied period
	Mon		X	No/Yes	Yes	Determines if this day is included in this schedule
	Tue		X	No/Yes	Yes	Determines if this day is included in this schedule
	Wed		X	No/Yes	Yes	Determines if this day is included in this schedule
	Thur		X	No/Yes	Yes	Determines if this day is included in this schedule
	Fri		X	No/Yes	Yes	Determines if this day is included in this schedule
	Sat		X	No/Yes	No	Determines if this day is included in this schedule
Sun	X	No/Yes	No	Determines if this day is included in this schedule		
Configuration ↓ Schedule ↓ Exception Schedules 1 - 12	Start Month	User/Admin Password level access	X	0 - 12	0	Defines the start month of this holiday schedule
	Start Day		X	0 - 31	0	Defines the start day of this holiday schedule
	Start Time		X	00:00 - 23:59	0:00	Determines the start time for this schedule
	End Month		X	0 - 12	0	Defines the month to end this holiday schedule
	End Day		X	0 - 31	0	Defines the day to end this holiday schedule
	End Time		X	00:00 - 24:00	0:00	Determines the time to end this schedule

LEGEND

BAS — Building Automation System
DCV — Demand Controlled Ventilation
IAQ — Indoor Air Quality
OAT — Outdoor Air Temperature
RH — Relative Humidity
SAT — Supply Air Temperature
SPT — Space Temperature
TPI — Third Party Integration

APPENDIX A — WSHP SCREEN OPEN CONFIGURATION (cont)

SCREEN NAME	POINT NAME	PASSWORD LEVEL	EDITABLE	RANGE	DEFAULT	NOTES
Configuration ↓ Unit Configuration	Fan Mode	Admin Password level access only	X	Auto/Continuous/ Always On	Continuous	Auto= Intermittant operation during both occupied and unoccupied periods/ Continuous = Intermittant during unoccupied periods and continuous during occupied periods/Always on = fan operates continuously during both occupied and unoccupied periods
	Fan On Delay		X	0 - 30 sec	10 sec	Defines the delay time before the fan begins to operate after heating or cooling is started
	Fan Off Delay		X	0 - 180 sec	45 sec	Defines the amount of time the fan will continue to operate after heating or cooling is stopped
	Heating Enable		X	Disable/Enable	Enable	Provides capability to manually disable heating operation
	Cooling Enable		X	Disable/Enable	Enable	Provides capability to manually disable cooling operation
	Minimum SAT in Cooling		X	40 - 60 ° F	50 ° F	Defines the minimum acceptable operating temperature for the Supply Air
	Maximum SAT in Heating		X	80 - 140 ° F	110 ° F	Defines the maximum acceptable operating temperature for the Supply Air
	Damper Ventilation Position		X	0 - 100%	100%	Normally set to 100% if 2 position damper type or set to minimum ventilation position if damper type = DCV
	DCV Maximum Vent Position		X	0 - 100%	100%	Usually set at 100% - Used to limit maximum damper opening in DCV mode
	Filter Alarm Timer		X	0 - 9999 hrs	0 hrs	Disables Filter Alarm if set to 0
	Pushbutton Override		X	Disable/Enable	Enable	Enables Override Feature on Rnet sensor
	SPT Sensor Set Point Adjustment		X	Disable/Enable	Enable	Enables Set Point adjustment capability on Rnet Sensor
	Lockout Cooling if OAT <		X	-65 - 80 ° F	-65 ° F	Cooling is locked out when OAT is less than configured value and OAT is actively being broadcast
	Lockout Heating if OAT >		X	35 - 150 ° F	150 ° F	Heating is locked out when OAT is greater than configured value and OAT is actively being broadcast
	Power Fail Restart Delay		X	0 - 600 sec	60 sec	Delay before equipment starts
	Occupancy Schedules		X	Disable/Enable	Enable	Enables unit occupied
Set Point Separation	X	2 - 9 ° F	4 ° F	Used to enforce minimum set point separation		
Configuration ↓ Service ↓ Test	Test Mode	Admin Password level access only	X	Disable/Enable	Disable	Used to enable test mode. Will automatically reset to disable after 1 hour
	Fan Test		X	Disable/Enable	Disable	Used to test all fan speeds. Sequences fan from low to high and operates each speed for 1 minute. Resets to disable on completion
	Fan Speed			Off/Low Speed/Medium Speed/High Speed/On		Displays current fan operation
	Compressor Test		X	Disable/Enable	Disable	Used to test compressor cooling and heating operation. Sequences cooling stage 1, then stage 2, then heating stage 2 and reduces capacity to stage 1. Operates for 1 minute per step. Resets to disable on completion.
	Dehumidification Test		X	Disable/Enable	Disable	Used to test dehumidification mode - Operates for 2 minutes. Resets to disable on completion.
	Testing Compressor			Inactive/Heating/Cooling/Dehumidify/TimeGard Wait		Displays compressor test mode
	Aux Heating Test		X	Disable/Enable	Disable	Used to test auxiliary heat. Sequences fan on and enables heating coil for 1 minute. Resets to disable on completion
	H ₂ O Economizer Test		X	Disable/Enable	Disable	Used to test entering/return air water loop economizer coil operation. Sequences fan on and opens economizer coil water valve for 1 minute. Resets to disable on completion
	Preposition OA Damper		X	Disable/Enable	Disable	Used to preposition OA damper actuator to set proper preload
	Open Vent Damper 100%		X	Disable/Enable	Disable	Used to test OA damper operation
	SAT			° F		Displays SAT
	LCWT			° F		Displays Leaving Condenser Water Temperature

LEGEND

BAS	— Building Automation System
DCV	— Demand Controlled Ventilation
IAQ	— Indoor Air Quality
OAT	— Outdoor Air Temperature
RH	— Relative Humidity
SAT	— Supply Air Temperature
SPT	— Space Temperature
TPI	— Third Party Integration

APPENDIX A — WSHP SCREEN OPEN CONFIGURATION (cont)

SCREEN NAME	POINT NAME	PASSWORD LEVEL	EDITABLE	RANGE	DEFAULT	NOTES
Configuration ↓ Service Configuration	# of Fan Speeds	Admin Password level access only	X	1,2,3	3	Used to set number of fan motor speeds
	G Output Type		X	Fan On/Fan Low	Fan On	When set to Fan On, G output is energized when ever any fan speed is active (required for ECM and Fan control board). When set to Fan Low, output is only energized for Low Speed
	Compressor Stages		X	One Stage/Two Stages	One Stage	Defines the number of stages of compression
	Reversing Valve Type		X	O type output/B type output	O type	Determines reversing valve signal output type
	Leaving Air Auxiliary Heat Type		X	None/2-Position HW/1 Stage Electric/Modulating HW	None	Determines Auxillary Reheat Coil Type
	Entering Air Water Economizer Type		X	None/2-Position/Modulating	None	Determines Entering Air Economizer Coil Type
	2-Position Water Valve Type		X	Normally Closed/Normally Open	Normally Closed	Determines type of 2-position water valve used
	Modulating Water Valve Type		X	Normally Closed/Normally Open	Normally Closed	Determines type of modulating water valve used
	Ventilation Damper Type		X	None/2-Position/DCV	None	Determines type of ventilation damper control to be used
	Damper Actuator Type		X	(0-10 volt)/(2-10 volt)	0-10 volt	Used to determine ventilation damper output signal range (closed - open)
	Humidity Sensor		X	None/Installed	None	Set to Installed if humidity sensor is present
	Factory Dehumidification Reheat Coil		X	None/Installed	None	Set to Installed if factory-installed dehumidification reheat coil is present
	Occupancy Input Logic		X	Occupied Open/Occupied Closed	Occupied CLOSED	Used to determine external occupancy switch contact occupied state
	Condensate Switch Alarm Delay		X	5 - 600 seconds	10 sec	Delay before equipment alarms on high condensate level
	Condensate Switch Alarm State		X	Alarm OPEN/Alarm CLOSED	Alarm CLOSED	Determine Alarm state of condensate switch input
	Minimum Condenser Water Temperature in Heating		X	25 - 60 ° F	60 ° F	Determines the minimum acceptable water loop temperature to start heating
	Maximum Condenser Water Temperature in Heating		X	65 - 100 ° F	90 ° F	Determines the maximum acceptable water loop temperature to start heating
	Minimum Condenser Water Temperature in Cooling		X	30 - 60 ° F	60 ° F	Determines the minimum acceptable water loop temperature to start cooling
	Maximum Condenser Water Temperature in Cooling		X	85 - 120 ° F	95 ° F	Determines the maximum acceptable water loop temperature to start cooling
	IAQ sensor minimum input		X	0 - 5 ma	4 ma	Minimum output current (mA) for IAQ sensor
	IAQ sensor maximum input		X	5 - 20 ma	20 ma	Maximum output current (mA) for IAQ sensor
IAQ sensor minimum output	X	0 - 9999 ppm	0 ppm	Corresponding value in ppm for minimum output current		
IAQ sensor maximum output	X	0 - 9999 ppm	2000 ppm	Corresponding value in ppm for maximum output current		

LEGEND

BAS	— Building Automation System
DCV	— Demand Controlled Ventilation
IAQ	— Indoor Air Quality
OAT	— Outdoor Air Temperature
RH	— Relative Humidity
SAT	— Supply Air Temperature
SPT	— Space Temperature
TPI	— Third Party Integration

APPENDIX A — WSHP SCREEN OPEN CONFIGURATION (cont)

SCREEN NAME	POINT NAME	PASSWORD LEVEL	EDITABLE	RANGE	DEFAULT	NOTES
Configuration ↓ Alarm Configuration	SPT Occupied Alarm Hysteresis	Admin Password level access only	X	2 - 20 ° F	5 ° F	Defines the hysteresis applied above the cooling and below the heating set points before an alarm condition will occur
	SPT Alarm Delay		X	0 - 30 min per degree	10 min	Used to calculate the delay time before an alarm is generated after the alarm condition occurs
	SPT Unoccupied Low Alarm Temperature		X	35 - 90 ° F	45 ° F	Defines the fixed unoccupied low SPT alarm limit
	SPT Unoccupied High Alarm Temperature		X	45 - 100 ° F	95 ° F	Defines the fixed unoccupied high SPT alarm limit
	SAT Low SAT Alarm Limit		X	15 - 90 ° F	45 ° F	Defines the fixed minimum SAT alarm limit
	SAT High SAT Alarm Limit		X	90 - 175 ° F	120 ° F	Defines the fixed maximum SAT alarm limit
	Condensate Overflow Alarm Delay		X	5 - 600 sec	10 sec	Defines the delay time before an alarm is generated after the alarm condition occurs
	Space Humidity Occupied High Alarm Limit		X	45% - 100%	100%	Defines the fixed occupied high space RH alarm limit
	Space Humidity Alarm Delay		X	0 - 30 min per % RH	5 min	Used to calculate the delay time before an alarm is generated after the alarm condition occurs
	Space Humidity Unoccupied High Alarm Limit		X	45% - 100%	100%	Defines the fixed unoccupied high space RH alarm limit
	IAQ/Ventilation Occupied High Alarm Limit		X	0 - 9999 ppm	1100 ppm	Defines the fixed occupied high space IAQ/Ventilation alarm limit
	IAQ/Ventilation Alarm Delay		X	0.1 - 1.0 min per ppm	0.25 min	Used to calculate the delay time before an alarm is generated after the alarm condition occurs
	Rnet Sensor SPT Alarm		X	Ignore/Display	Ignore	Determines if the SPT alarm is displayed on the local Rnet sensor
	Rnet Sensor SAT Alarm		X	Ignore/Display	Ignore	Determines if the SAT alarm is displayed on the local Rnet sensor
	Rnet Sensor Compressor Lockout Alarm		X	Ignore/Display	Display	Determines if the Compressor Lockout alarm is displayed on the local Rnet sensor
	Rnet Sensor Condenser Water Temperature Alarm		X	Ignore/Display	Display	Determines if the Condenser Water Temperature alarm is displayed on the local Rnet sensor
	Rnet Sensor Condensate Overflow Alarm		X	Ignore/Display	Display	Determines if the Condensate Overflow alarm is displayed on the local Rnet sensor
	Rnet Sensor Dirty Filter Alarm		X	Ignore/Display	Display	Determines if the Dirty Filter alarm is displayed on the local Rnet sensor
Rnet Sensor Space High Humidity Alarm	X	Ignore/Display	Ignore	Determines if the High Space RH alarm is displayed on the local Rnet sensor		
Configuration ↓ Linkage	Loop Control Network Number					See TPI
	Loop Control Network Address					See TPI
	Number of Linked Heat Pumps					See TPI

LEGEND

BAS — Building Automation System
DCV — Demand Controlled Ventilation
IAQ — Indoor Air Quality
OAT — Outdoor Air Temperature
RH — Relative Humidity
SAT — Supply Air Temperature
SPT — Space Temperature
TPI — Third Party Integration

**50PSH,PSV,PSD
START-UP CHECKLIST**

CUSTOMER: _____ JOB NAME: _____
MODEL NO.: _____ SERIAL NO.: _____ DATE: _____

I. PRE-START-UP

DOES THE UNIT VOLTAGE CORRESPOND WITH THE SUPPLY VOLTAGE AVAILABLE? (Y/N) _____

HAVE THE POWER AND CONTROL WIRING CONNECTIONS BEEN MADE AND TERMINALS TIGHT? (Y/N) _____

HAVE WATER CONNECTIONS BEEN MADE AND IS FLUID AVAILABLE AT HEAT EXCHANGER? (Y/N) _____

HAS PUMP BEEN TURNED ON AND ARE ISOLATION VALVES OPEN? (Y/N) _____

HAS CONDENSATE CONNECTION BEEN MADE AND IS A TRAP INSTALLED? (Y/N) _____

IS AN AIR FILTER INSTALLED? (Y/N) _____

II. START-UP

IS FAN OPERATING WHEN COMPRESSOR OPERATES? (Y/N) _____

IF 3-PHASE SCROLL COMPRESSOR IS PRESENT, VERIFY PROPER ROTATION PER INSTRUCTIONS. (Y/N) _____

UNIT VOLTAGE — COOLING OPERATION

PHASE AB VOLTS _____ PHASE BC VOLTS _____ PHASE CA VOLTS _____
(if 3 phase) (if 3 phase) (if 3 phase)

PHASE AB AMPS _____ PHASE BC AMPS _____ PHASE CA AMPS _____
(if 3 phase) (if 3 phase) (if 3 phase)

CONTROL VOLTAGE

IS CONTROL VOLTAGE ABOVE 21.6 VOLTS? (Y/N) _____.
IF NOT, CHECK FOR PROPER TRANSFORMER CONNECTION.

TEMPERATURES

FILL IN THE ANALYSIS CHART ATTACHED.

COAXIAL HEAT EXCHANGER	COOLING CYCLE:	FLUID IN	_____ F	FLUID OUT	_____ F	_____ PSI	_____ FLOW
	HEATING CYCLE:	FLUID IN	_____ F	FLUID OUT	_____ F	_____ PSI	_____ FLOW
AIR COIL	COOLING CYCLE:	AIR IN	_____ F	AIR OUT	_____ F		
	HEATING CYCLE:	AIR IN	_____ F	AIR OUT	_____ F		

HEATING CYCLE ANALYSIS

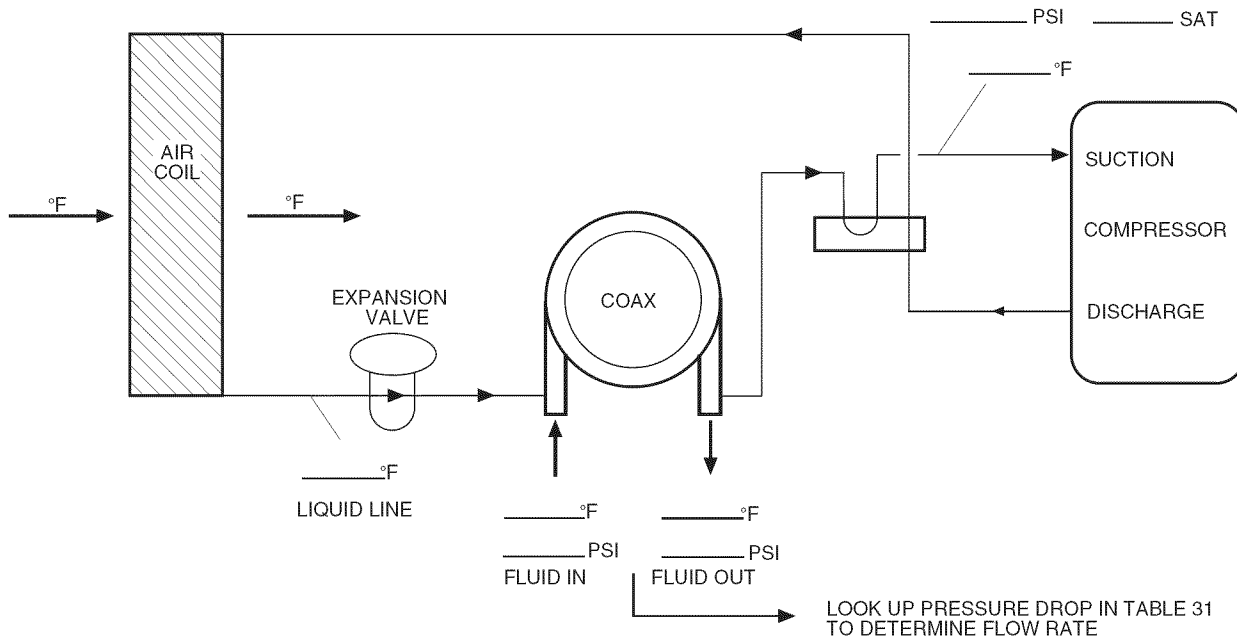

COOLING CYCLE ANALYSIS

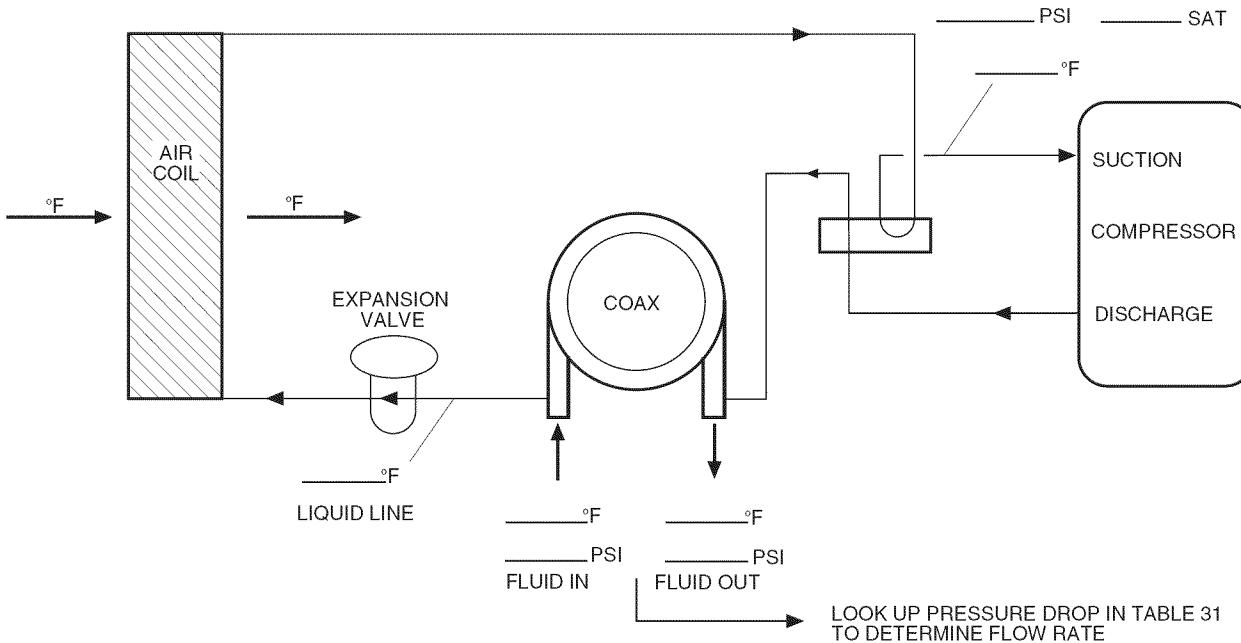

HEAT OF EXTRACTION (ABSORPTION) OR HEAT OF REJECTION =

$$\text{FLOW RATE (GPM)} \times \text{TEMP. DIFF. (DEG. F)} \times \text{FLUID FACTOR}^* = \text{_____ (Btu/hr)}$$

SUPERHEAT = SUCTION TEMPERATURE – SUCTION SATURATION TEMPERATURE
= _____ (DEG F)

SUBCOOLING = DISCHARGE SATURATION TEMPERATURE – LIQUID LINE TEMPERATURE
= _____ (DEG F)

*Use 500 for water, 485 for antifreeze.

97B0038N04

CUT ALONG DOTTED LINE