

# User Manual



## User Manual



### In the box

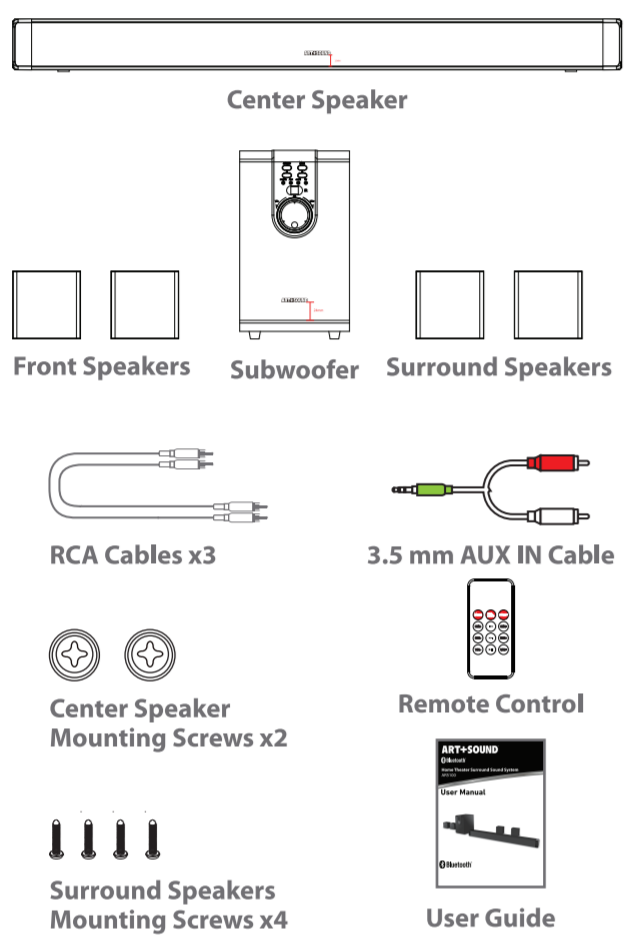

### Installing the battery

The battery for the remote control (1 CR2025 Lithium Battery) is included. To replace the battery, push and slide out the battery door on the remote control. Replace the battery with a new CR2025 battery with the positive (+) polarity facing up. Slide the battery door back in to the remote control.

**NOTE:** The ARS100 remote is packaged with a plastic protection tab. Before operating the remote, gently pull the protective tab extending out of the remote control's battery door.

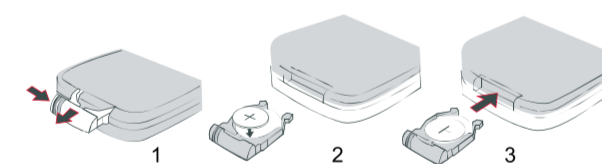

### Location of controls

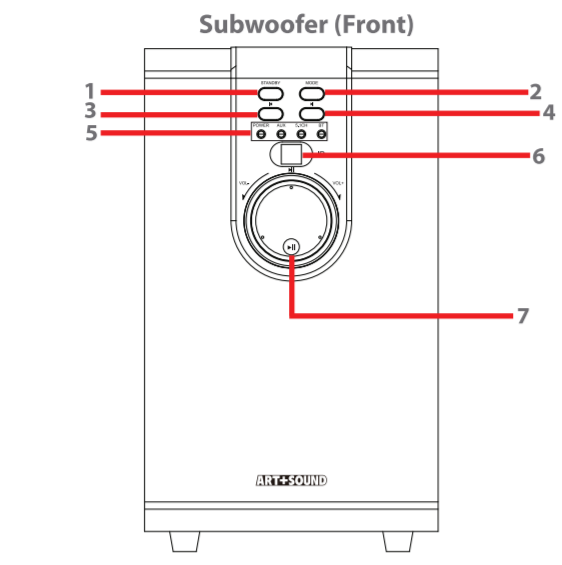

- [STANDBY] Button:** Power ON/OFF
- [MODE] Button:** AUX IN; 5.1CH IN; Bluetooth
- [ ] Button:** Skip to previous track
- [ ] Button:** Skip to next track
- [ ]:** LED indicator lights (power and modes)
- [ ]:** Infrared remote sensor
- [ ]:** Volume dial
- [ ]:** Press=Play/Pause
- [ ]:** Turn=Control volume

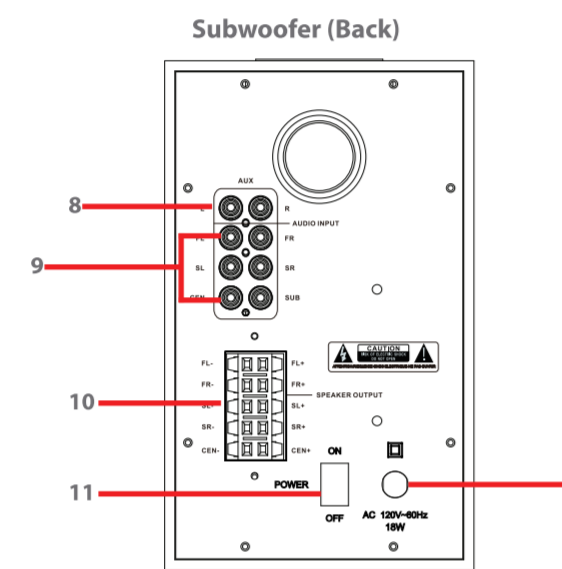

- RCA/AUX INPUT JACKS (2 PORT)
- 5.1 CH INPUT JACKS (6 PORT)
- SPEAKER OUTPUT JACKS
- POWER SWITCH
- AC POWER CORD

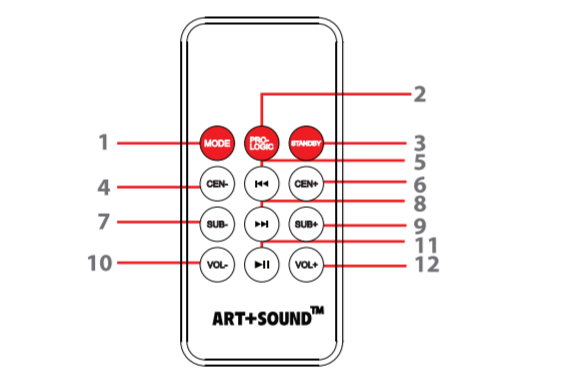

- [MODE] button:** AUX IN, Bluetooth
- [PRO-LOGIC] button:** Virtual 5.1 surround sound
- [STANDBY] button:** In AUX mode=mute sound  
In Bluetooth mode=play/pause  
In 5.1CH mode=power ON/OFF
- [CEN-] button:** Decrease volume on center speaker
- [ ] button:** Skip to previous track
- [CEN+] button:** Increase volume on center speaker
- [SUB-] button:** Subwoofer decrease volume
- [ ] button:** Skip to next track
- [SUB+] button:** Increase subwoofer volume
- [VOL-] button:** Decrease volume to all 6 speakers
- [ ] button:** Play/Pause music
- [VOL+] button:** Increase volume to all 6 speakers

### Mounting the speaker

- Center Speaker:**
- Measure a width of 26.8 inches on the wall where you would like the Center Speaker to be placed.
  - Mark the position of the mounting screws on the wall using a pencil.
  - Drill the 2 center speaker mounting screws (the larger screw heads) into the marks you have made on the wall and leave approximately 0.3 inch space to hook the Center Speaker on.
  - Place the Center Speaker onto the mounting screws. Make sure it is firm and stable.

- Surround Speakers:**
- Mark the position of the mounting screws on the walls using a pencil where you would like your front and rear speakers.
  - Drill the 4 Surround Speaker mounting screws (the smaller screw heads) into the marks you have made on the walls and leave approximately 0.3 inch space to hook the Surround Speakers on.
  - Place the Surround Speakers onto the mounting screws. Make sure they are firm and stable.

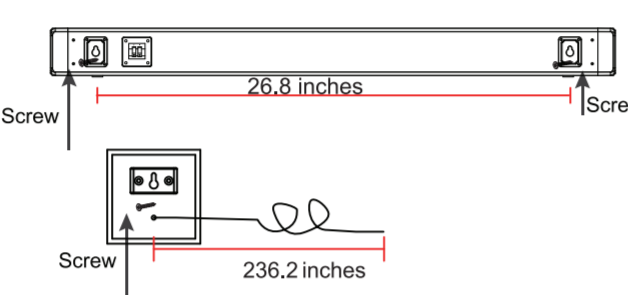

### Connecting a TV, DVD player, etc.

There are two types of RCA inputs on the ARS100. The first is 2-port left and right channel, the second is a 6-port 5.1CH surround sound. If your TV, DVD player, etc. has only 2 ports of audio output, refer to "2-Port Input" below. If your TV, DVD player, etc. has 6 ports of audio output, then refer to "6-Port Input" below.

- 2-Port Input (AUX)**
- Connect one end of an included RCA cable to your TV's, DVD Player's or other device's **Audio-OUT** jacks on the TV, DVD or other (Red and White RCA output jacks are usually labeled **Audio-OUT**).
  - Connect the other end of the included RCA cable to the (L) and (R) audio input jacks on the back of the subwoofer.

- 6-Port Input (5.1CH)**
- Note: Your TV, DVD player or other device needs to have 6 RCA output jacks for 5.1 surround RCA output. Your device's output jacks may be labeled differently than shown below.
- Connect one end of an included RCA cable to your TV's, DVD Player's or other device's **"Front Left"** and **"Front Right"** output jacks on the TV, DVD or other (Red and White RCA output jacks usually labeled **FL** and **FR**).
  - Connect the other end of the included RCA cable to the **FL** and **FR** audio input jacks on the back of the subwoofer.
  - Connect one end of another included RCA cable to your TV's, DVD Player's or other device's **"Surround Left"** and **"Surround Right"** output jacks on the TV, DVD or other (Red and White RCA output jacks usually labeled **SL** and **SR**).
  - Connect the other end of the included RCA cable to the **SL** and **SR** audio input jacks on the back of the subwoofer.
  - Connect one end of another included RCA cable to your TV's, DVD Player's or other device's **"Center"** and **"Subwoofer"** output jacks on the TV, DVD or other (Red and White RCA output jacks usually labeled **CEN** and **SUB**).
  - Connect the other end of the included RCA cable to the **CEN** and **SUB** audio input jacks on the back of the subwoofer. Be sure to match the colors correctly. For example, if the RED tip is connected to **SUB** on your TV make sure the other RED tip is connected to **SUB** on the back of the subwoofer.

### Connecting a TV, DVD player, etc. (cont'd)

- When connected to 6-port input, the input selection on the ARS100 will be **5.1CH**.

**NOTE:** If you connect your TV or DVD etc using the 6-port method, you can also connect another device to the L and R input jacks. Use the Mode button to select between 5.1CH (6-port input) and AUX (2-port input).

- Connecting the Speakers**
- Place the speakers where you would like them in your room. See "Mounting the Speakers".
  - Match the red and black wires from each speaker to the **SPEAKER OUTPUT** jacks on the back of the subwoofer.
- FL = Front Left Speaker  
FR = Front Right Speaker  
SL = Surround Left Speaker  
SR = Surround Right Speaker  
CEN = Center Speaker

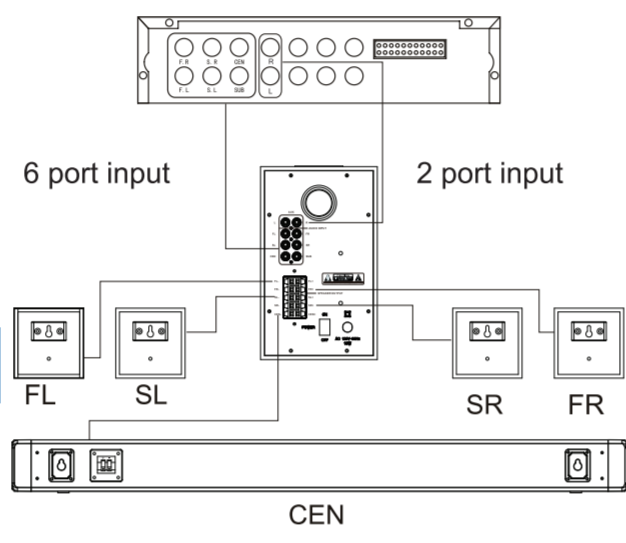

### Pairing the speaker with a Bluetooth enabled device (cont'd)

- Connect the AC power cord into a wall socket.
- Turn the speaker on by pressing the **[STANDBY]** button on the speaker or remote control.
- Press the **[MODE]** button on the speaker or remote control to enter Bluetooth Mode. A tone is heard and the Bluetooth LED indicator light will flash quickly.
- Keep the speaker and your Bluetooth enabled device within three feet of each other during the pairing process.
- Set your mobile phone or other Bluetooth enabled device to search for compatible Bluetooth devices.

**NOTE:** If there are no paired devices in range when the speaker is turned on, it will go into pairing mode automatically. If a paired device is in range, the speaker will connect to it automatically.

- On an iPhone**
- Go to **SETTINGS > BLUETOOTH** (Make sure Bluetooth is turned ON)

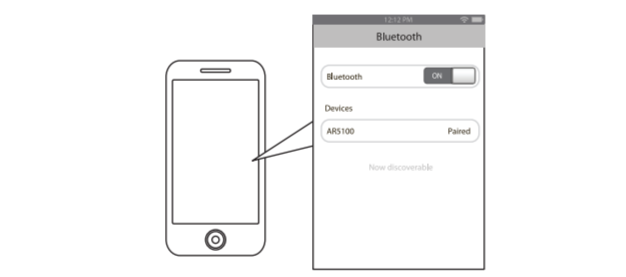

### Pairing the speaker with a Bluetooth enabled device (cont'd)

- On a BlackBerry**
- Go to **SETTINGS/OPTIONS > BLUETOOTH**
  - Enable **BLUETOOTH** (Make sure Bluetooth is turned ON)



- On an Android Phone**
- Go to **SETTINGS > BLUETOOTH > MENU > Search for devices** (Make sure Bluetooth is turned ON)

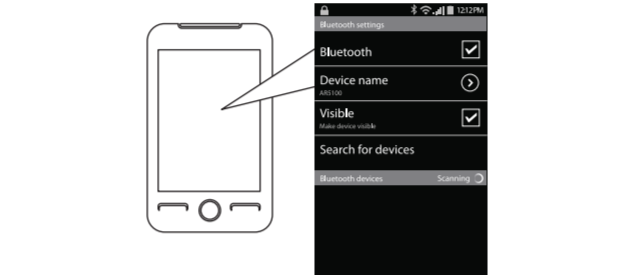

- On other Cell Phones/Devices**
- Review the instruction manual that came with your phone/device.

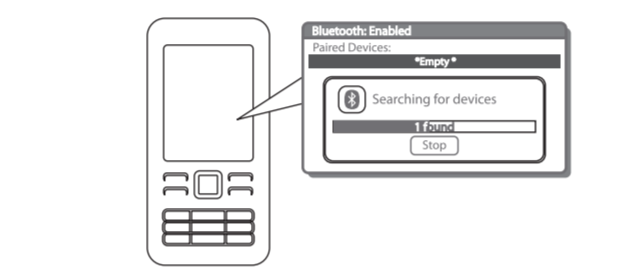

**NOTE:** The screenshots above are typical of many Bluetooth enabled devices in the market today, and are used to assist in the explanation of the pairing process. Your Bluetooth enabled device's interface and interaction with the speaker may differ slightly from the illustrations shown.

### Using the speaker

#### Powering ON/OFF

- Turn the speaker ON and OFF by pressing the **[POWER]** switch on the back of the unit.
- Once the **[POWER]** switch is on, you can control the power using the subwoofer **[STANDBY]** button.

#### Adjusting the volume

- Use the volume dial on the front of the subwoofer to raise and lower the volume. Turn left to decrease the volume and turn right to increase the volume.
- You can also use the **[VOL+]** and **[VOL-]** buttons on the remote control to raise or lower the volume.

#### Switching modes

Press the **[MODE]** button on the subwoofer or the **[MODE]** button on the remote to switch between the

- 5.1CH** = the 6-port input on the back of the subwoofer
- BT** = Bluetooth Device (see "Pairing the Speaker with a Bluetooth enabled device")

**NOTE:** You can choose **5.1CH** in any mode. It will split the sound to all 6 speakers.

### Playing music

#### Playing music wirelessly

To enjoy listening to music wirelessly on your ARS100, make sure you are connected to a Bluetooth enabled device. Once connected, press **PLAY** on your Bluetooth device. After playback starts, you can control the music with your connected device or the buttons of the ARS100 (with devices that have the AVRCP Bluetooth profile).

#### Play/Pause

- Press the **[VOLUME]** dial in on the subwoofer or press the **[STANDBY]** button on the remote control to pause the music. To resume music playback, press the **[VOLUME]** dial on the subwoofer or the **[STANDBY]** button on the remote control again.

#### Skipping Songs

- Press the **[ ]** button on the remote control to skip to the previous song
- Press the **[ ]** button on the remote control to skip to the next song

#### Adjusting the volume

- To raise the volume turn the **[VOLUME]** dial on the speaker to the right or press the **[VOL+]** button on the remote control.
- To lower the volume turn the **[VOLUME]** dial on the speaker to the left or press the **[VOL-]** button on the remote control.

### Connecting a smartphone, tablet, etc.

- Connect the red and white tips of the **3.5 mm AUX-IN cable** to the **RCA/AUX INPUT JACKS (2-PORT)** on the back of the subwoofer.
- Connect the other end of the **3.5 mm AUX-IN cable** to an external device's headphone jack (smartphone, tablet, MP3 player, etc).
- Use the **[MODE]** button on the subwoofer or remote control to select **AUX**.
- Open the media player on your device and click on **PLAY** to start playing your music.
- Use the controls on your connected device to control music playback.

**NOTE:** When a device is plugged into the RCA/AUX jack, the speaker and remote control buttons have limited function. You must use your connected device to control music playback.

### Troubleshooting tips

**Q:** My Bluetooth Device is not able to pair with the subwoofer.

- Make sure the subwoofer is turned ON before beginning the pairing process.
- Keep the subwoofer and Bluetooth enabled device within 3 feet of each other during the pairing process.
- Press the **[MODE]** button on the speaker or remote control to enter Bluetooth Mode. A tone is heard and the Bluetooth LED indicator light flashes blue quickly.
- Check that YOUR device's Bluetooth feature is turned ON.
- Try repeating the pairing process. Refer to "Pairing the Speaker with a Bluetooth Enabled Device."

**Q:** I can pair the subwoofer with my Bluetooth device, but I cannot hear any music.

- Make sure your Bluetooth device supports A2DP profile.
- Turn up the volume on your Bluetooth device.
- You may have to unpair the speaker, then re-pair to your device.

**Q:** I cannot get the Wireless Speaker Bar into Pairing Mode.

- Make sure the subwoofer is turned ON before beginning the pairing process.
- Press the **[MODE]** button on the speaker or remote control to enter Bluetooth Mode. A tone is heard and the Bluetooth LED indicator light flashes quickly.
- The speaker is now in pairing mode.

### Safety instructions

- Read these instructions.
- Keep these instructions.
- Heed all warnings.
- Follow all instructions.
- Do not use this apparatus near water.
- Clean only with a dry cloth.
- Do not block any ventilation openings. Install in accordance with the manufacturer's instructions.
- Do not install near any heat sources such as radiators, heat registers, stoves, or other apparatus (including amplifiers) that produce heat.
- Do not defeat the safety purpose of the polarized or grounding-type plug. A polarized plug has two blades with one wider than the other. A grounding type plug has two blades and a third grounding prong. The wide blade or the third prong are provided for your safety. When the provided plug does not fit into your outlet, consult an electrician for replacement of the obsolete outlet.
- Protect the power cord from being walked on or pinched particularly at plugs, convenience receptacles, and the point where they exit from the apparatus.
- Only use attachments/accessories specified by the manufacturer.
- Use only with a cart, stand, tripod, bracket, or table specified by the manufacturer, or sold with the apparatus. When a cart is used, use caution when moving the cart/apparatus combination during lightning storms or when unused for long periods of time.



- Unplug the apparatus during lightning storms or when unused for long periods of time.
- Refer all servicing to qualified service personnel. Servicing is required when the apparatus has been damaged in any way, such as power-supply cord or plug is damaged, liquid has been spilled or objects have fallen into the apparatus, the apparatus has been exposed to rain or moisture, does not operate normally, or has been dropped.

- WARNING:** The mains plug is used as a disconnect device: the disconnect device shall remain readily operable.
- WARNING:** To reduce the risk of fire or electric shock, do not expose this apparatus to rain or moisture. The apparatus shall not be exposed to dripping or splashing, and objects filled with liquids, such as vases, shall not be placed on apparatus.
- WARNING:** This equipment is a Class II or double insulated electrical appliance. It has been designed in such a way that it does not require a safety connection to electrical earth.



**CAUTION:** The battery has not been assembled under an approved process and should not be used for other than the intended purpose. Do not attempt to repair or modify the battery. Do not use the battery for other than the intended purpose. Do not use the battery for other than the intended purpose. Do not use the battery for other than the intended purpose.

### Additional warnings and precautions

Battery shall not be exposed to excessive heat such as sunshine, fire or the like. Danger of explosion if battery is incorrectly replaced. Replace only with the same or equivalent type.

**CAUTION:** TO PREVENT ELECTRIC SHOCK, MATCH WIDE BLADE OF PLUG TO WIDE SLOT, FULLY INSERT.

**CAUTION:** Use of controls or adjustments or performance of procedures other than those specified may result in hazardous radiation exposure.

**WARNING:** Changes or modifications to this unit not expressly approved by the party responsible for compliance could void the user's authority to operate the equipment.

**WARNING:** Do not place this unit directly onto furniture surfaces with any type of soft, porous, or sensitive finish. As with any rubber compound made with oils, the feet of this unit may cause marks or staining where they reside. We recommend using a protective barrier such as a cloth or a piece of glass between the unit and the surface to reduce the risk of damage and/or staining.

**WARNING:** Use of this unit near fluorescent lighting may cause interference regarding use of the remote. If the unit is displaying erratic behavior move away from any fluorescent lighting, as it may be the cause.

**WARNING:** Shock hazard - Do Not Open.  
**WARNING:** TO REDUCE THE RISK OF ELECTRIC SHOCK, DO NOT REMOVE COVER (OR BACK). NO USER-SERVICEABLE PARTS INSIDE. REFER SERVICING TO QUALIFIED SERVICE PERSONNEL.

#### FCC Radiation Exposure Statement

This equipment complies with FCC radiation exposure limits set forth for an uncontrolled environment. This equipment should be installed and operated with minimum distance 20cm between the radiator & your body.

### Legal information

Caution: Any changes or modifications not expressly approved could void the user's authority to operate the equipment.

Note: This equipment has been tested and found to comply with the limits for a Class B digital device, pursuant to part 15 of the FCC Rules. These limits are designed to provide reasonable protection against harmful interference in a residential installation. This equipment generates, uses and can radiate radio frequency energy and, if not installed and used in accordance with the instructions, may cause harmful interference to radio communications. However, there is no guarantee that interference will not occur in a particular installation. If this equipment does cause harmful interference to radio or television reception, which can be determined by turning the equipment off and on, the user is encouraged to try to correct the interference by one or more of the following measures:

- Reorient or relocate the receiving antenna.
- Increase the separation between the equipment and receiver.
- Connect the equipment into an outlet on a circuit different from that to which the receiver is connected.
- Consult the dealer or an experienced radio/TV technician for help.

### Limited Warranty

**90 Days Limited Warranty**  
In the unlikely event that this product is defective, or does not perform properly, you may within ninety (90) days from your original date of purchase return it to the authorized service center for repair or exchange.

- TO OBTAIN WARRANTY SERVICE:**
- Call the Customer Support number located below, or go to our website portal to receive an SRD number.
  - Provide proof of the date of purchase within the package (Dated bill of sale).
  - Prepay all shipping costs to the authorized service center, and remember to insure your return.
  - Include a return shipping address (no P.O. Boxes), a telephone contact number, and the defective unit within the package.
  - Describe the defect or reason you are returning the product.

Your product will be repaired or replaced, at our option, for the same or similar model of equal value if examination by the service center determines this product is defective. Products received damaged as a result of shipping will require you to file a claim with the carrier.

The shipping address of the authorized service center is:  
**Southern Telecom, Inc.**  
**Attention: Customer Service (2nd Floor)**  
**Brooklyn, NY 11232**  
**14-C 53rd Street**

Should you have any questions or problems concerning this product, please contact our customer service department at:  
**Customer Support:**  
Phone: 1-877-768-8481  
Monday-Friday 8AM-10PM(EST)  
[www.southern telecom.com](http://www.southern telecom.com)  
Click on "Product Support"

**Warranty service not provided**  
This warranty does not cover damage resulting from accident, misuse, abuse, improper installation or operation, lack of reasonable care, and unauthorized modification. This warranty is voided in the event any unauthorized person opens, alters or repairs this product. All products being returned to the authorized service center for repair must be suitably packaged.

**Limitation of Warranty:**  
THE WARRANTY STATED ABOVE IS THE ONLY WARRANTY APPLICABLE TO THIS PRODUCT. ALL OTHER WARRANTIES, EXPRESS OR IMPLIED, INCLUDING ALL IMPLIED WARRANTIES OF MERCHANTABILITY OR FITNESS FOR A PARTICULAR PURPOSE ARE HEREBY DISCLAIMED. NO VERBAL OR WRITTEN INFORMATION GIVEN BY A.T. INC.'S AGENTS, OR EMPLOYEES SHALL CREATE A GUARANTY OR IN ANY WAY INCREASE THE SCOPE OF THIS WARRANTY.

**REPAIR OR REPLACEMENT AS PROVIDED UNDER THIS WARRANTY IS THE EXCLUSIVE REMEDY OF THE CONSUMER. A.T. INC. SHALL NOT BE LIABLE FOR INCIDENTAL OR CONSEQUENTIAL DAMAGES RESULTING FROM THE USE OF THIS PRODUCT OR ARISING OUT OF ANY BREACH OF ANY EXPRESS OR IMPLIED WARRANTY ON THIS PRODUCT. THIS DISCLAIMER OF WARRANTIES AND LIMITED WARRANTY ARE GOVERNED BY THE LAWS OF THE STATE OF NEW YORK. EXCEPT TO THE EXTENT PROHIBITED BY APPLICABLE LAW, ANY IMPLIED WARRANTY OF MERCHANTABILITY OR FITNESS FOR A PARTICULAR PURPOSE OR THIS PRODUCT IS LIMITED TO THE APPLICABLE WARRANTY PERIOD SET FORTH ABOVE.**

Some states do not allow the exclusion nor limitation of incidental or consequential damages, or limitations on how long an implied warranty lasts so the above limitations on exclusions may not apply to you. This warranty gives you specific legal rights, and you also may have other rights that vary from state to state.

The Bluetooth® word mark and logos are owned by the Bluetooth SIG, Inc.

