



2.4 GHz Cordless Telephone with Digital Answering Machine & Caller ID on Call Waiting

40 CHANNEL AUTOSCAN WITH 4 SEPARATE MAILBOXES

Model GH9492

OWNER'S MANUAL
INSTALLATION AND
OPERATING
INSTRUCTIONS

***PLEASE READ THIS
MANUAL CAREFULLY
BEFORE USE.
KEEP FOR YOUR
REFERENCE.***



For installation information, please see "Getting Started" instructions on page 6 or your separate Quick Start Guide.

Visit Us on the Web:
www.uselectronics.info
© 2004 Bellsouth Corporation

Special Features

Congratulations on your selection of a quality **BellSouth** product. With proper care, and by following the set-up and user instructions in this Owners Manual, this unit will provide you with years of trouble-free service.

BellSouth is committed to providing quality products that fit your needs. We would like to have any comments or suggestions you might have on this product. You may mail your comments to:

U.S. Electronics
105 Madison Avenue
New York, NY 10016

When examining your new **BellSouth** cordless telephone, you will find an array of special features including:

CORDLESS TELEPHONE FEATURES

Filtered Sound™ System - Gets considerably less noise than conventional cordless telephones because of a special circuit which delivers the clearest possible reception.

40 Channel Auto Scan - Press the  button on the **HANDSET** to find and lock on to the clearest channel for any call.

Desk or Wall Mount - Use this equipment as a desk phone or as a wall phone.

TONE or PULSE Dialing - Use this phone for either TONE (push-button) or PULSE (rotary) dialing.

Automated Functions - Redial the last number called and automatic STANDBY mode.

Security - Ensures greater privacy because a built-in security code with 65,536 combinations prevents use of your telephone line by another nearby cordless phone.

Dependable Battery - Recharge your BATTERY PACK many times with the built-in charger. The battery low warning tone tells you when the BATTERY PACK needs recharging. (See page 38.)

Special Services - Use the  button to access special services such as Call Waiting supplied by your telephone company or company switchboard.

STANDBY Mode - When in STANDBY mode (ON-HOOK), the phone is capable of receiving a call. When the **HANDSET** is on the **BASE UNIT**, it is automatically in the STANDBY mode (ON-HOOK). When the **HANDSET** is taken off the **BASE UNIT**, it remains in the STANDBY mode until you activate the  button.

Battery Power Saver - Once fully charged, in STANDBY mode, the **HANDSET** can receive/send calls for a maximum of five days without the need for recharging. Length of charge depends on frequency of use.

Luminous LCD Screen - The LCD Screen emits light for 5 seconds every time you press any of the buttons on the **HANDSET**.

HANDSET Ringer Level - Select the ringer volume level (HI, LOW, OFF).

HANDSET VOLUME CONTROL Switch - Select the receiver volume level (HI, MID, LOW).

HEADSET JACK - Your telephone can utilize a headset for hands-free communication.

BELT CLIP - Use the BELT CLIP to hang your **HANDSET** on your belt.

Special Features

CALLER ID SYSTEM

Multi-Function Large LCD Screen - Shows the number you are dialing, and with Caller ID service (available through subscription from your local telephone company), displays information about the caller before you answer the call.

Name and Number DIRECTORY - Stores up to 40 names and numbers so that you can call them with a single key stroke.

Caller List - Available with Caller ID service. Stores up to 80 calls to keep track of everyone who called. The name, phone number, time, and date of the call are recorded. Allows you to return their calls with a single key stroke.

Preferred Calls - You can mark the name and number of a welcome caller in the DIRECTORY. When that number calls in, the caller's name will appear on the LCD Screen and a special ring sound will be heard.

Blocked Calls - You can mark the name and number of an unwelcome caller in the DIRECTORY. When that number calls in, the caller's name will appear on the LCD Screen and the ringer will be disabled.

Repeat Call Indicator - Shows if a new incoming call has called more than once.

Out of Area Call Indicator - Advises you that the incoming call is not in a Caller ID service area, or does not support the Caller ID system.

Private Call Indicator - Advises you that the caller's name and/or telephone number of the incoming call is blocked by the system.

Call Waiting Service - Displays the name and number of the second caller, if you have subscribed to call waiting service from your local telephone company (See page 15).

Voice Mail - Indicates message waiting signal if you subscribed to Voice Mail message service and requested Visual Message Indication from your local telephone company (see page 15). This telephone also detects a Stutter Dial Tone signal every time there is a Voice Mail message for your Voice Mail message provider if you have subscribed to Voice Mail message service.

ANSWERING SYSTEM FEATURES

Fully Digital Answering System - Provides a full range of answering functions without using cassette tapes.

Digital Memory - Allows recording of memos and messages.

Two Digit LED Message Display - Indicates the number of messages, indicates the status of the system.

Ring-Detection Selectable - Choose the number of times the telephone rings before the system answers.

Voice Day/Time Stamp - Systems tells the day and time of each received message or recorded memo.

Message Alert - The ability to generate a sound signal when new messages are recorded.

Call Screening - The ability to intercept a call when the unit is recording an incoming message (ICM).

Mailboxes - Allows four separate individuals to receive their own incoming messages.

Auto Disconnection - Will automatically stop answering when **HANDSET** of any phone on the same line is lifted.

Fast Message Skip Function - Skips to the next message.

Remote Control Capable - Can be accessed through an outside line (Tone telephone) via 3-digit access code.



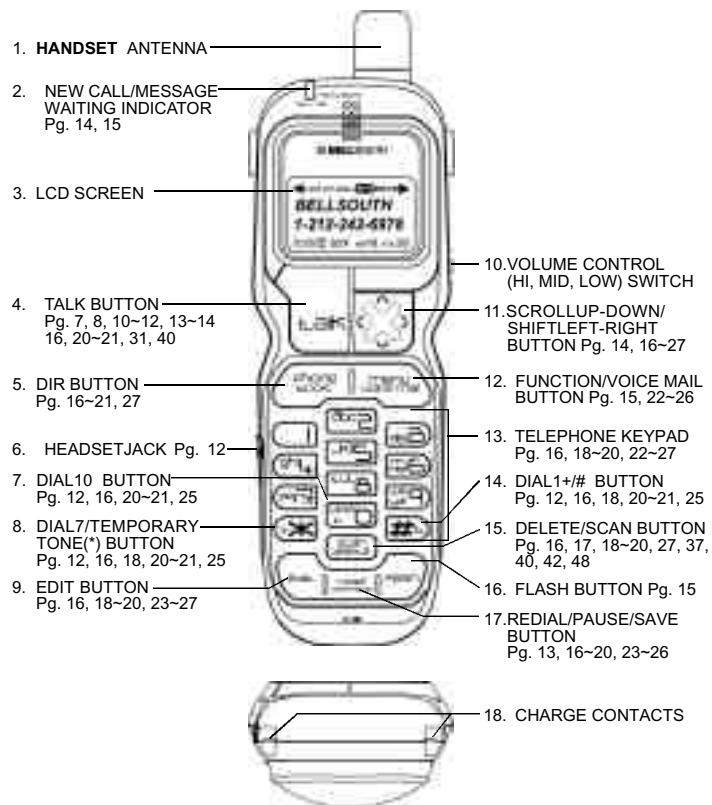









HANDSET Controls



HANDSET Controls

1. **HANDSET ANTENNA**
2. **NEW CALL/MSG (MESSAGE) WAITING LED Indicator:** Blinks when recording a new incoming call or when receiving a Message Waiting signal, if you have subscribed to a Voice Mail message service from your local telephone company. (See page 14 for details.)
3. **LCD Screen:** Shows call information, phone status, prompts, and DIRECTORY items.
4. **TALK  Button:** Press to answer an incoming call or to place a call. Press to end a call.

HANDSET Controls

5. **DIR (DIRECTORY)**  **Button:** Press to access names and numbers stored in the DIRECTORY. (See pages 16 to 21 for details.)
6. **HEADSET JACK:** For connecting your headset plug to enjoy hands-free communication. (See page 12 for detail.)
7. **DIAL 10/0**  **Button:** (DIAL 10) Press and hold down to place a local call with Area Code.
8. **DIAL7/TEMPORARY TONE**  **Button:** (DIAL7) Press and hold down to place a local call. (*) Press to temporarily change the DIALING mode from PULSE to TONE for Rotary Service Users. (Press once before entering numbers to access the answering system or electronic banking service, etc.)
9. **EDIT**  **Button:** Press to edit listed items.
10. **HANDSET VOLUME CONTROL(HI, MID, LOW) Switch:** Select the receiver volume level (HI, MID, LOW).
11. **SCROLL UP-DOWN, SHIFT LEFT-RIGHT**  **Button:** Press to move around the large LCD Screen.
12. **FUNC (FUNCTION)/VOICE MAIL**  **Button:** (FUNCTION) Press to access special functions operation in STANDBY mode. (For special functions see pages 22 ~ 26.) (VOICE MAIL) - Press to automatically dial the Voice Mail Post Code in your area to access your Voice Mail message.
13. **TELEPHONE KEYPAD**  ~  **Buttons:** Allows you to make a call depending on pressed button. (For TELEPHONE KEYPAD characters, see page 27.)
14. **DIAL 1+/#**  **Button:** (DIAL 1+) Press and hold down to place a long distance call. (Automatically adds the number 1 at the beginning of the displayed telephone number.)
15. **DELETE/SCAN**  **Button:** (DELETE) Press and hold down to delete items or individual characters. (SCAN) Press to change the operating channel when you hear interference.
16. **FLASH**  **Button:** Press to answer a call if you have Call Waiting.
17. **SAVE/RE(REDIAL)/PA(PAUSE)**  **Button:** (SAVE) Press and hold down to save the changes on the listed items. (REDIAL) Press to redial the last number you dialed. (PAUSE) Press to insert a pause while dialing. (You will need the  button to dial numbers which use an alternative Long Distance Access Code.)
18. **CHARGE CONTACTS:** For charging the BATTERY PACK inside the **HANDSET**. We recommend cleaning the CHARGE CONTACTS periodically with a damp cloth.

BASE UNIT Controls

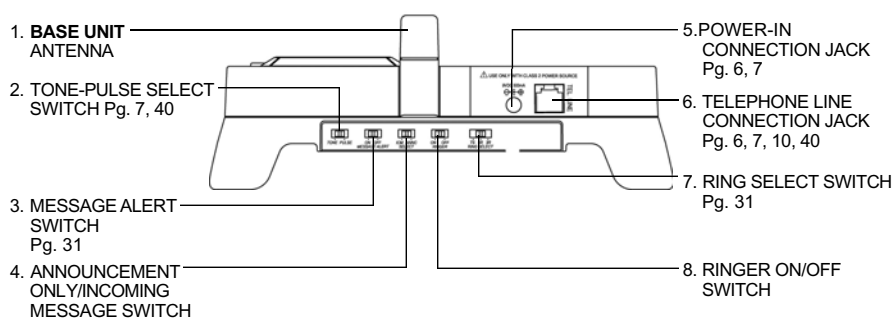

BASE UNIT Control

1. **BASE UNIT ANTENNA**
2. **TONE/PULSE Select Switch**
3. **MESSAGE ALERT Switch:** Set switch to ON to generate a “beep” sound every 15 seconds when a new message has been received.
4. **ANNOUNCEMENT ONLY/INCOMING MESSAGE Switch:**
 - ICM** - System records the incoming messages.
 - ANNC** - System plays your announcement and then hangs up without recording messages.
5. **POWER-IN CONNECTION JACK**
6. **TELEPHONE LINE CONNECTION JACK**
7. **RING SELECT Switch:** To select the number of rings before the Answering System answers a call.
 - 3R** - System answers a call after third ring.
 - 5R** - System answers a call after the fifth ring.
 - TS (TOLL SAVER)** - System answers after the third ring only if you have new message. Otherwise, the system will answer after the fifth ring.
8. **RINGER ON/OFF Switch:** Set switch to OFF position to disengage the ringer on the **BASE UNIT**.

IMPORTANT

Placing your BASE UNIT near appliances such as televisions, refrigerators, radios, or microwave ovens may cause interference.

BASE UNIT Controls

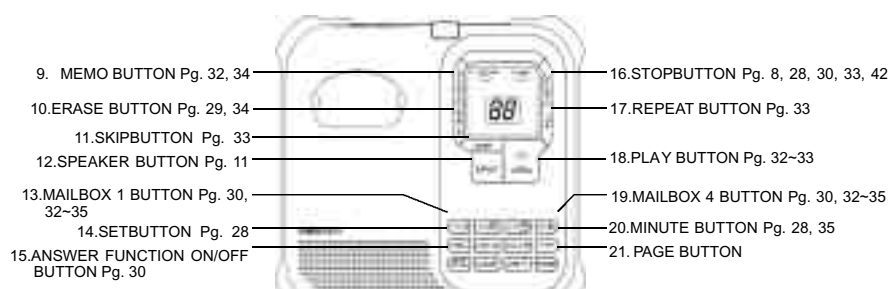





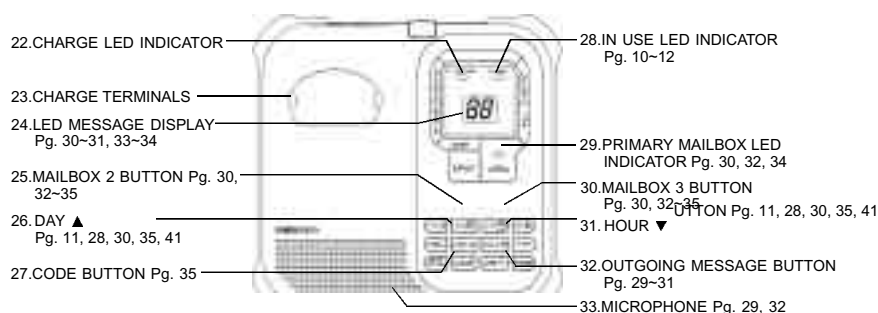

BASE UNIT Controls - Answering System

9. **MAILBOX 2 LED Indicator:** Lights up to indicate message(s) are present, and blinks when MAILBOX 2 is active and ready to operate.
9. **MEMO** **memo** **Button:** Press and hold down to record memo messages.
10. **ERASE** **erase** **Button:** Press to erase messages.
11. **SKIP** **skip** **Button:** Press to skip messages.
12. **SPEAKER** **speaker** **Button:** Press to answer the incoming call using the **BASE UNIT**.
13. **MAILBOX 1** **m 1** **Button:** Press to activate functions for MAILBOX 1.
14. **SET** **set** **Button:** Press to set/check the day and time.
15. **ANSWER FUNCTION ON/OFF** **ans on/off** **Button:** Press to activate or deactivate the answer function. The ANSWER FUNCTION ON/OFF LED indicator lights when the Answer function is turned ON.
16. **STOP** **stop** **Button:** Press to stop playing a message. Press and hold down for more than 3 seconds to initiate/re-initiate your answering machine, then release the button and a "beep" will sound. (See detail operations on pages 28 and 41.)
17. **REPEAT** **rpt** **Button:** Press to repeat messages.
18. **PLAY** **play** **Button:** Press to play messages.
19. **MAILBOX 4** **m 4** **Button:** Press to activate functions for MAILBOX 4.
20. **MINUTE** **min** **Button:** Press to set the minute during time setting, or press to set the third digit of the access code during code setting.
21. **PAGE** **page** **Button:** Press to page **HANDSETS**.

BASE UNIT Controls



22. **CHARGE LED Indicator:** Lights up when the **HANDSET** is placed on the **BASE UNIT** for charging.
23. **CHARGE TERMINALS:** For charging the **HANDSET BATTERY PACK**. For best performance, clean the **CHARGE TERMINALS** periodically with a damp cloth.
24. **LED MESSAGE DISPLAY:** Indicates the number of memos/messages received, status of the system.
ER - Erase *OP* - OGM is playing *01 ~ 53* - No. of memos/messages
AO - Announce Only *FU* - Memory is full *PR* - Pause
25. **MAILBOX 2  Button:** Press to activate functions for MAILBOX 2.
26. **DAY  Button:** Press to set the day during time setting, or press to set the first digit of the access code during code setting.
27. **CODE  Button:** Press to set the 3-digit Remote Access Code for remote operation.
28. **IN USE LED Indicator:** Lights up to indicate that the **HANDSET** is in TALK mode.
29. **PRIMARY MAILBOX LED Indicator:** Lights up to indicate message(s) are present, and blinks when PRIMARY MAILBOX is active and ready to operate.
30. **MAILBOX 3  Button:** Press to activate functions for MAILBOX 3.
31. **HOUR  Button:** Press to set the hour during time setting, or press to set the second digit of the access code during code setting.
32. **OUTGOING MESSAGE  Button:** Press and hold down to record OGM message.
33. **MICROPHONE**

Contents

Safety Instructions	4
Getting Started	6
Desk Mounting	9
Cordless Telephone Operation	10
Preparing for Use	10
NO LINE Indicator	10
Receiving Calls From the HANDSET	10
Receiving Calls Using the BASE UNIT SPEAKERPHONE	11
Placing Calls	12
Headset Feature	12
Redial Feature	13
Caller ID System Operation	14
Caller ID System	14
Viewing Caller Information During Incoming Calls	14
MSG WAITING (Message Waiting)	14
Call Waiting	15
Voice Mail Function	15
C-F (Forwarded Call)	15
L-D-C (Long Distance Call)	15
Caller List	15
Viewing the Caller List	16
Placing a Call From the Caller List	16
Editing the Caller List before Dialing	16
Saving the Name and Number in the Caller List into the DIRECTORY	17
Deleting All Records in the Caller List	17
Selective Deleting in the Caller List	17
Name and Telephone Number DIRECTORY	17
Viewing the DIRECTORY	17
Speed Viewing the DIRECTORY	18

Contents

Saving in the DIRECTORY	18
PREFERRED CALLS	18
BLOCKED CALLS	18
Editing a Name and Number in the DIRECTORY	19
Editing the Number in the DIRECTORY before Dialing	20
Placing Calls from the DIRECTORY	21
Deleting All Records in the DIRECTORY	21
Selective Deleting in the DIRECTORY	21
Function Operation	22
A. Language	23
B. First Ring/Silent On or Off	23
C. Time Set	23
D. Ringer Volume	24
E. LCD Contrast	24
F. PBX Number	24
G. Flash Time	25
H. Pause Time	25
I. Voice Mail	26
J. MSG Waiting (Message Waiting)	26
Telephone Keypad Characters	27
Answering System Operation	28
Resetting the Answering System	28
Setting the Day/Time Stamp	28
Recording your Outgoing Messages	29
Adjusting the Speaker Volume	30
Turning the Answering System ON/OFF	30
Setting to Answer Calls	31
Setting to Announce Only	31
Screening Incoming Calls	31

Contents

Message Alert	31
Setting Ring Select	31
Recording a Memo	32
Playing of Messages/Memos	32
Saving Messages	33
Erasing Messages	34
When the Memory is Full	34
Two-Way Recording	34
Remote Control Operation	35
Remote Operation through a Tone Telephone	35
Remote Access Codes	35
Changing of the Remote Access Code	35
Using the Remote Instruction Code	36
Security	37
Recharging the Battery Pack	38
Changing the Battery Pack	39
Problem Solving	40
Technical Information	42
FCC Requirements	43
Warranty	45
Wall Mounting Template	47

Safety Instructions

IMPORTANT SAFETY INSTRUCTIONS

To reduce the risk of fire, electric shock and/or injury, always follow these basic safety precautions when using your cordless telephone equipment.

1. Read and understand all instructions.
2. Follow all warnings and instructions marked on the telephone.
3. Unplug this telephone from the wall outlet before cleaning or replacing the BATTERY PACK. Do not use liquid cleaners or aerosol cleaners on the telephone. Use a damp cloth for cleaning.
4. Do not use this telephone near water, for example, near a bath tub, wash bowl, kitchen sink, or laundry tub, in a wet basement, or near a swimming pool.
5. Place this telephone on a stable surface. Serious damage and/or injury may result if the telephone falls.
6. Do not cover the slots and openings on this telephone. This telephone should not be placed near or over a radiator or heat register. This telephone should not be placed in a built-in installation unless proper ventilation is provided.
7. Operate this telephone using the electrical voltage as stated on the **BASE UNIT** of the telephone or in the Owner's Manual. If you are not sure of the voltage in your home, consult your dealer or local power company.
8. Do not place anything on the power cord. Install the telephone where no one will step or trip on the cord.
9. Do not overload wall outlets or extension cords as this can increase the risk of fire or electric shock.
10. Never push objects of any kind through the slots in the telephone. They could touch dangerous voltage points or short out parts that could result in a risk of fire or electric shock. Never spill liquid of any kind on the telephone.
11. To reduce the risk of electric shock, do not disassemble this telephone. Take it to a qualified service representative when service or repair work is required. Opening or removing covers may expose you to dangerous voltages or other risks. Incorrect reassembly can cause electric shock when the telephone is subsequently used.
12. Unplug this telephone from the wall outlet and consult a qualified service representative in any of the following situations:
 - A. When the power supply cord is frayed or damaged.
 - B. If liquid has been spilled into the telephone.
 - C. If the telephone has been exposed to rain or water.
 - D. If the telephone does not operate normally by following the operating instructions. Adjust only those controls that are covered by the operating instructions. Improper adjustment of other controls may result in damage and will often require extensive work by a qualified technician to restore the telephone to normal operation.

Safety Instructions

- E. If the telephone has been dropped or the case has been damaged.
- F. If the telephone exhibits a distinct change in performance.
- 13. Do not use the telephone to report a gas leak in the vicinity of the leak.
- 14. Never install telephone wiring during a lightning storm.
- 15. Never install telephone jacks in wet locations unless the jack is specifically designed for wet locations.
- 16. Never touch uninsulated telephone wires or terminals unless the telephone line has been disconnected at the network interface.
- 17. Use caution when installing or modifying telephone lines.

Battery Safety

CAUTION:

Danger of explosion if the BATTERY PACK is replaced with incorrect type. Replace only with the same or equivalent type. To reduce the risk of fire or personal injury, read and follow these instructions:

1. Use only the following type and size of BATTERY PACK:
 - Cordless Telephone BATTERY PACK
 - 3.6V, 600mAh
 - XACT Communication
 - Ni-MH BATTERY PACK: Model B655
 - (See page 38 for ordering information.)
2. Do not dispose of the BATTERY PACK in a fire. The BATTERY PACK may explode. Check with local codes for possible special disposal instructions.
3. Do not open or mutilate the BATTERY PACK. Released electrolyte is corrosive and may cause damage to the eyes or skin. Electrolyte may be toxic if swallowed.
4. Exercise care in handling the BATTERY PACK to prevent shorting the BATTERY PACK with conductive materials such as rings, bracelets, and keys. The BATTERY PACK or conductor may overheat and cause burns.
5. Charge the BATTERY PACK provided with (or identified for use with) this telephone only in accordance with the instructions and limitations specified in this manual.
6. Observe proper polarity orientation between the BATTERY PACK and BATTERY CHARGER.

SAVE THESE INSTRUCTIONS

ATTENTION:

The telephone that you have purchased contains a rechargeable BATTERY PACK. The BATTERY PACK is recyclable. At the end of its useful life, under various state and local laws, it may be illegal to dispose of this BATTERY PACK into the municipal waste stream. Check with your local solid waste officials for details in your area for recycling options or proper disposal.

Getting Started

Connecting Your Phone

This section is a reference guide to the basic functions and operations of your cordless telephone. For more detailed descriptions of the operations and features of this telephone, refer to the Contents on page 1.

1. Carefully remove your cordless telephone from its shipping carton. If there is any visible damage, do not attempt to operate this equipment. Return it to the place of purchase.
2. Check to be sure you have all items that come with this cordless telephone system. You should have a **HANDSET**, **BASE UNIT**, AC ADAPTER, TELEPHONE LINE CORD, SHORT TELEPHONE LINE CORD, BELT CLIP, and an Owner's Manual.



HANDSET



BASE UNIT



BELT CLIP



**TELEPHONE
LINE CORD**



**SHORT TELEPHONE
LINE CORD**

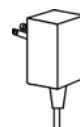

AC ADAPTER



**BATTERY
PACK**

3. Insert the small plug on the end of the AC ADAPTER into the POWER-IN CONNECTION JACK at the back of the **BASE UNIT**.
4. Plug the AC ADAPTER into a 120V AC wall outlet.



USE ONLY WITH CLASS 2 POWER SOURCE 9V DC, 500 mA.

5. Insert one plug of the TELEPHONE LINE CORD into the house TELEPHONE JACK and the other end into the TELEPHONE LINE CONNECTION JACK at the back of the **BASE UNIT**. (If you have an older 4-prong TELEPHONE JACK, you will need an RJ-11C TELEPHONE JACK ADAPTER. This adapter is available at the same place you purchased your telephone.)
6. We recommend not placing this unit next to appliances. Doing so may cause interference.

Getting Started

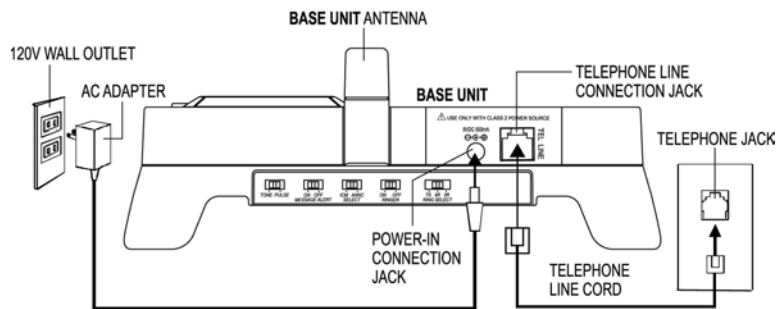

7. Install the **HANDSET BATTERY PACK** by plugging it into the **BATTERY CONNECTOR** inside the **BATTERY COMPARTMENT**. The **HANDSET LCD Screen** will display "RING: HI".
8. Place the **BATTERY PACK** inside the **BATTERY COMPARTMENT**.
9. Slide the **HANDSET BATTERY COMPARTMENT COVER** firmly into place in its closed position.
10. **IMPORTANT: Before initial use, charge the HANDSET for 12 hours. Do not charge the HANDSET with the KEYPAD face down.**
11. **TONE/PULSE Select Switch:**
 - A. If your home is equipped with a tone dialing system, set the **TONE/PULSE Select Switch** to the **TONE** position.
 - B. If you have a rotary dialing system, set the **TONE/PULSE Select Switch** to the **PULSE** position.
 - C. If you are unsure which system you have, set the **TONE/PULSE Select Switch** to the **TONE** position. Press the **talk** button on the **HANDSET** to get a dial tone and make a call. If the call connects, leave the switch as is; otherwise set to the **PULSE** position.

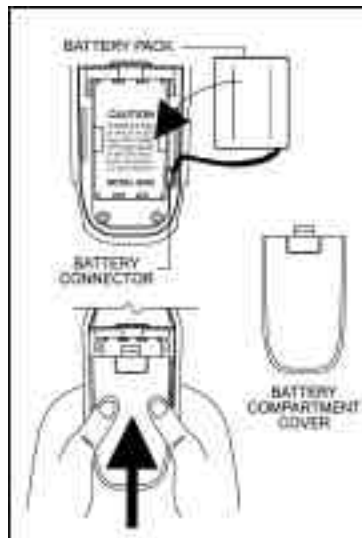

Getting Started

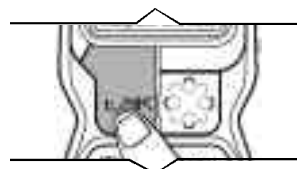
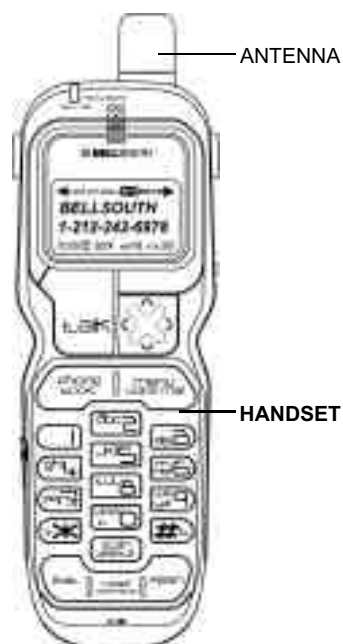

Press the **talk** button to confirm that you have a dial tone. If you do not get a dial tone, review steps 3 through 11. If you still do not have a dial tone, refer to the Problem Solving section on page 40.

BELT CLIP HOOK



With the back of the **HANDSET** facing up, insert one side of the **BELT CLIP HOOK** into the matching slot at the top side of the **HANDSET**. Press down on the opposite side of the **BELT CLIP** until the other **HOOK** locks into the slot on the side of the **HANDSET**.

12. Set the date and time on the **HANDSET**. (See page 23 for details.)
13. Press and hold the **stop** button to initiate your Answering System. (See details on page 28.)
14. Set the date and time on the **BASE UNIT**. (See page 28 for details.)

*You are now ready to use your new
BellSouth Cordless Telephone.*

IMPORTANT

In order to utilize the Caller ID feature, you must subscribe to Caller ID service from your local telephone company.

Desk Mounting

Desk Mounting

1. Place the **BASE UNIT** on any desired but suitable location.
2. Put the **HANDSET** into its cradle with the LCD Screen faces you.



- IMPORTANT:**
1. A "beep" will be heard when the **HANDSET** is properly positioned in the **BASE UNIT CHARGE CRADLE** and charging. Securely positioning the **HANDSET** in the **BASE UNIT** will also prevent the **HANDSET** from falling.
 2. The **BASE UNIT** does not have the **WALLMOUNTING** Feature.

IMPORTANT

Placing your BASE UNIT near appliances such as televisions, refrigerators, radios, or microwave ovens may cause interference.

Cordless Telephone Operation

Preparing for Use

Before you can use your cordless telephone, you must charge the **HANDSET** for 12 hours. Failure to do so will require recharging of the **BATTERY PACK** more often.

1. Place the **HANDSET** on the **BASE UNIT** for 12 hours.
2. After 12 hours, remove the **HANDSET** from the **BASE UNIT**.

Before you can use your cordless telephone, you must charge the HANDSET for 12 hours. Failure to do so will require more frequent charging of the BATTERY PACK. See page 38 for more information on the BATTERY PACK.

NOTE:

Depending on the frequency of use, once the **HANDSET** is fully charged, it remains functional for approximately 4 hours of continuous use and approximately 5 days when the **HANDSET** is off the **BASE UNIT** in **STANDBY** mode.

NO LINE Indicator

This telephone checks for an active **TELEPHONE LINE** connection. If "NO LINE" appears on the **LCD Screen**, when the **HANDSET** is in **STANDBY** mode, no calls can be made or received from this telephone. Check that the **TELEPHONE LINE CORD** plugs are connected to the wall **TELEPHONE JACK** and the **BASE UNIT TELEPHONE LINE CONNECTION JACK**. If "NO LINE" continues to be displayed, check that the other phones in the house are working. If none of the phones work, contact your local phone company.

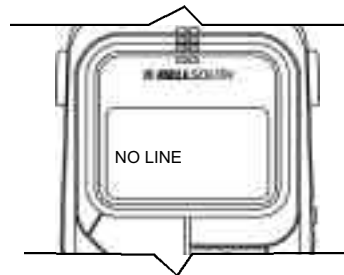

Receiving Calls From the HANDSET

1. When the phone rings, lift the **HANDSET** and press the **talk** button. The **HANDSET LCD Screen** will display "CALLS" and "TALKING", and the **BASE UNIT IN USE LED** indicator will light up.
2. Start your conversation.
3. To end your conversation, either press the **talk** button or place the **HANDSET** on the **BASE UNIT**. If you place the **HANDSET** on the **BASE UNIT CHARGE CRADLE**, you activate the automatic **STANDBY** feature.

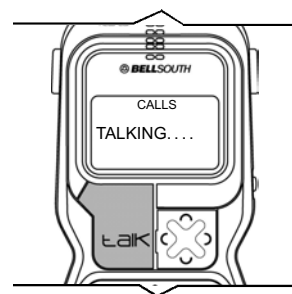



Cordless Telephone Operation

NOTE:

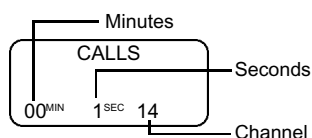
1. The Call Timer will start to count once you press the **talk** button.
2. The LCD Screen emits light for 5 seconds every time you press any buttons on the **HANDSET**.
3. When "CALLS" appears on the LCD Screen, it means that the **HANDSET** is OFF-HOOK (connected to the telephone line).



Receiving Calls Using the BASE UNIT SPEAKERPHONE

1. When the phone rings, press the **speaker** button and begin speaking.
2. The LED Message Display will show "88".
3. The SPEAKERPHONE speaker volume can be adjusted by pressing the  and . The LED Message Display will indicate the speaker volume as:
"0" - Speaker off
"1-8" - Volume from low to high
4. To hang up, press the **speaker** button again.



IMPORTANT

In order to utilize the Caller ID feature, you must subscribe to Caller ID service from your local telephone company.

Cordless Telephone Operation

Placing Calls

1. Press the **talk** button, the Call Timer starts to count. The **HANDSET** LCD Screen will display “CALLS”, and “TALKING”, and the **BASE UNIT** IN USE LED indicator will light up.
2. Listen for a dial tone.
3. Dial the phone number.
4. When you have finished with your call, press the **talk** button again or place the **HANDSET** on the **BASE UNIT**.

OR

1. Dial the phone number.
2. Press and hold down the DIAL 7 **7*** or the DIAL 10 **10** or the DIAL 1+ **1*#** button. The **BASE UNIT** IN USE LED indicator will light up.
3. When you have finished with your call, press the **talk** button again or place the **HANDSET** on the **BASE UNIT**.



Headset Feature

Your telephone can utilize a headset (not included) to be connected to your **HANDSET** for you to enjoy hands-free communication. Pull out the **HEADSET JACK COVER**, then insert the small plug at the end of the headset into the **HEADSET JACK** at the right side of the **HANDSET**. Follow the procedures discussed in “Receiving Calls” and “Placing Calls” to receive and place a call.

NOTE: When you plug the headset plug into the **HEADSET JACK** it automatically mutes the **MICROPHONE** and **SPEAKER** of the **HANDSET**. Unplug the headset to return the **HANDSET** to normal use.

Headsets are available at most retail outlets that sell telephone equipment. The **HEADSET JACK** is compatible with 2.5mm headset plugs only.

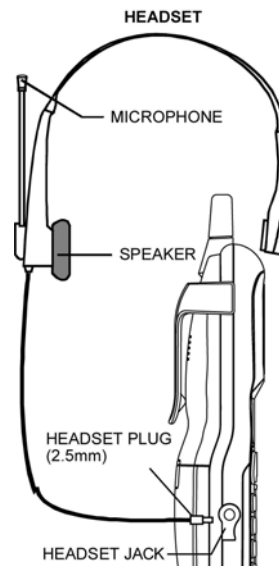

Cordless Telephone Operation

Redial Feature

1. If you get a busy tone, press the **talk** button or place the **HANDSET** on the **BASE UNIT** to hang up.
2. Later, press the **talk** button again.
3. Listen for a dial tone.
4. Press the **redial save/pause** button. This will automatically redial the last telephone number you called in TALK mode.
5. When you have finished with your call, press the **talk** button again (the **BASE UNIT IN USE LED** indicator will turn off) or place the **HANDSET** on the **BASE UNIT**.



NOTE:

If you are too far away from the **BASE UNIT**, the **HANDSET** emits “beep” sounds to warn you that the background noise level is too high for proper communication between the **HANDSET** and the **BASE UNIT**. When you hear this sound, you should move closer to the **BASE UNIT** to reduce the noise level. Otherwise, the call will automatically cut off.

Caller ID System Operation

Caller ID System

This telephone automatically displays an incoming caller's name and telephone number together with the date and time of the call. It records up to 80 calls and stores the data in Memory.

IMPORTANT: You must subscribe to the Caller ID service from your local telephone company to utilize this feature.

Viewing Caller Information During Incoming Calls

1. When there is an incoming call, the name and the telephone number of the caller will automatically appear after the first ring. Press the SHIFT RIGHT  button to view a name of more than 11 characters.

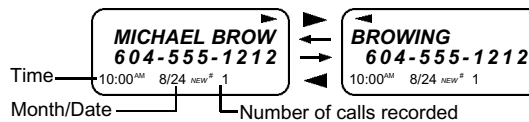

OR

Caller's telephone number will appear if the caller's name is not available.

OR

"OUT OF AREA" will appear if the origin of the incoming call does not support the Caller ID system.

e.g.
OUT OF AREA
O-----
10:00^{AM} 8/24 ^{NEW#} 13 ^{TOTAL} 42

OR

"UNKNOWN" will appear if the origin of the incoming call has no name and does not support the Caller ID system.

e.g.
UNKNOWN
U-----
10:00^{AM} 8/24 ^{NEW#} 13 ^{TOTAL} 42

OR

"PRIVATE" and/or "P-----" will appear if the caller's name and/or telephone number is blocked.

OR

"DATA ERROR" will appear if wrong data was received from the telephone line.

OR

The name stored in the DIRECTORY will appear for an incoming call with matching telephone numbers.

MSG WAITING (Message Waiting)

The MSG WAITING GREEN LED indicator will blink when there is a message for you from your telephone company if you have subscribed to Voice Mail message service and if you have requested Visual Message Indication from your local telephone company. "MSG WAITING" will appear on the LCD Screen in STANDBY mode. (To remove the MESSAGE WAITING indicator, see page 26 for detail.)

Caller ID System Operation

Call Waiting

When you subscribe to a Call Waiting service from your local telephone company, this telephone will display the name and number of the second caller while you are having a conversation with your first caller.

1. When you are having a conversation, this telephone will automatically display the name and number of the second caller. The name will blink.

2. Press the **flash** button to answer the second caller. The first caller's name and number will be displayed. The name will blink.

3. When you have finished, press the **flash** button to continue your conversation with the first caller.

If you do not want to interrupt your phone conversation with the first caller, you can advise the second caller to leave a Voice Mail message instead.

e.g. 
1st Caller

e.g. 
2nd Caller

Voice Mail Function

When there is a Voice Mail message for you, this telephone detects a Stutter Dial Tone (if applicable) and the "MSG" icon on the LCD Screen and the MESSAGE WAITING LED indicator will blink.

1. To access your Voice Mail message, press the **talk** button.

2. After you hear a dial tone, press the **menu voice mail** button. This will automatically dial the Voice Mail Post Code in your area and connect you to the Voice Mail service provider.

NOTE: You must store the Voice Mail Post Code number by using the VOICE MAIL function on page 26. You can also call your Voice Mail service provider by dialing the Voice Mail Access Code number after pressing the **talk** button.

C-F (Forwarded Call)

Appears on the upper left hand side of the LCD Screen, when the incoming call has been assigned to your telephone number.

L-D-C (Long Distance Call)

Appears on the upper left hand side of the LCD Screen, when the incoming call is a long distance call and the service is provided by your local telephone company.

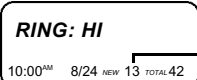

Caller List

Records call information for up to 80 incoming calls such as caller's name and telephone number together with the date and time of the call. After recording a new incoming call, the NEW CALL indicator will blink and the LCD Screen will display:

 No. of new calls
Maximum calls= 80

Caller ID System Operation





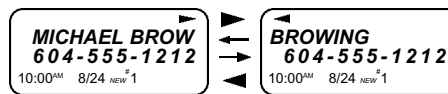

Viewing the Caller List

1. Press the SCROLL DOWN  button to view the latest Caller ID record, or press the SCROLLUP  button to view the first Caller ID record, press the SHIFTRIGHT  button if the name has more than 11 characters.



2. Press the  button to return to STANDBY mode. (If no active buttons are pressed for 20 seconds or you have viewed the last Caller ID record in the Callers List, the LCD Screen will automatically return to STANDBY mode.)













Placing a Call from the Caller List

1. With the **HANDSET** in STANDBY mode, press the SCROLLDOWN  button to select from the latest Caller ID record, or press the SCROLLUP  button to select from the first Caller ID record.
2. Press and hold down the DIAL 7  button for a local call, or the DIAL 10  button for a local call with area code, or the DIAL1+  button for a long distance call.
3. To end your conversation, either press the  button or place the **HANDSET** on the **BASE UNIT**.

To place a call from the Caller List while in TALK mode, press the  button, then follow steps 1 through 3.

NOTE: You can edit the number before dialing, but you can not SAVE any changes in the Caller List.

Editing the Caller List before Dialing

1. Press the SCROLL UP  or DOWN  button to find the Caller ID record.
2. Press the  button.
3. Move the cursor by pressing the SHIFTLLEFT  or RIGHT  button to the digit you want to change. To erase digits, press the  button. To add digits, use the TELEPHONE KEYPAD  ~  buttons.
4. Press and hold down the DIAL 7  button for a local call, the DIAL10  button for a local call with area code, or the DIAL 1 +  button for a long distance call.
5. To end your conversation, either press the  button or place the **HANDSET** on the **BASE UNIT**.

To save the edited record from the Caller List, follow steps 1 through 3 then press and hold down the  button.

Caller ID System Operation

Saving the Name and Number in the Caller List into the DIRECTORY

1. Press the SCROLL UP ▲ or DOWN ▼ button to find the Caller ID record.
2. Press and hold down the  button. The LCD Screen will show "SAVED".



NOTE: It is not advisable to save a telephone number without the corresponding name. This will lead to improper display on PRIVATE and OUT OF AREAcalls.

Deleting All Records in the Caller List

1. Press and hold down the  button for at least 3 seconds while in STANDBY mode.
2. The LCD Screen will automatically return to STANDBY mode.



Selective Deleting in the Caller List

1. Press the SCROLL UP ▲ or DOWN ▼ button to find the Caller ID record while in STANDBY mode.
2. Press and hold down the  button for at least 3 seconds, then the LCD Screen will display the next Caller ID record in the CALLER LIST.
3. Press the  button to return to STANDBY mode.



Name and Telephone Number DIRECTORY

This DIRECTORY lets you scroll through the list to find the record you need for one touch dialing. You can store up to 40 names and telephone numbers in the memory.

Viewing the DIRECTORY

1. Press the  button.



No. of records stored

2. Press the SCROLL UP ▲ or DOWN ▼ button to find the record you wish to view. Press the SHIFT RIGHT ► button to view a name or telephone number of more than 11 characters.

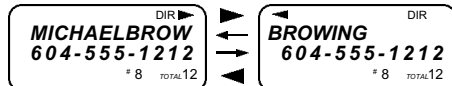



NOTE: To exit the DIRECTORY List at anytime, press the  button.













Caller ID System Operation

Speed Viewing the DIRECTORY

1. Press the  button.
2. Enter the first letter of a name. (See Page 27 for detail of entering a letter.)
3. Press the SCROLLUP  button to view all names with the same first letter.

Saving in the DIRECTORY

1. Press the  button.
2. Press the  button.
3. Use the TELEPHONE KEYPAD  ~  buttons to enter the name, (see page 27 for detail) you can store up to 15 characters. To move the cursor to the right, create a space, or to enter a new letter, press the SHIFT RIGHT  button.
4. Press the SCROLLDOWN  button once.
5. Enter the telephone number using the TELEPHONE KEYPAD  ~  buttons. You can store up to 16 digits.
6. Press and hold down the  button.
7. Press the  button to go back to STANDBY mode.
(If no active buttons are pressed for 20 seconds, the LCD Screen will automatically return to STANDBY mode.)

NOTES: 1. It will not save a duplicate telephone number or a name without the corresponding telephone number in the DIRECTORY.

2. To delete a character or number inside the cursor, press the  button.

PREFERRED CALLS

You can assign stored numbers a PREFERRED CALL status which will generate a special ringer sound at the start of the second ring to any welcome caller in the DIRECTORY.

When you are saving the name and number into the DIRECTORY, add a “#” symbol at the beginning of the name by pressing the  button.



BLOCKED CALLS

You can assign stored numbers a BLOCKED CALL status which will disable the ringer sound after the second ring to any caller in the DIRECTORY.

When you are saving the name and number into the DIRECTORY, add an “*” symbol at the beginning of the name by pressing the 7  button.

Caller ID System Operation

Editing a Name and Number in the DIRECTORY













1. Press the  button. The LCD Screen will display "DIRECTORY".
2. Press the SCROLL UP  or DOWN  button to find the record you want to edit.



3. Press the  button to edit the name, and the cursor will blink over the first character.



■ cursor is blinking

4. Press the SCROLLLEFT  or RIGHT  button to move the cursor to the letter or number you want to change. To erase, press the  button. To add, use the TELEPHONE KEYPAD  ~  buttons. (See page 27 for details.)
5. Press the SCROLL UP  or DOWN  button to edit the number.
6. Press the SCROLLLEFT  or RIGHT  button to move the cursor to the digit you want to change. To erase, press the  button. To add, use the TELEPHONE KEYPAD  ~  buttons. (See page 27 for details.)



⌘ cursor is blinking





7. Press and hold down the  button to confirm.

IMPORTANT: It is not advisable to save a telephone number without the corresponding name in the DIRECTORY. This will lead to improper displays on PRIVATE and OUT OF AREA calls.

NOTE: When no active buttons are pressed for 20 seconds, the LCD Screen will automatically return to STANDBY mode.









Caller ID System Operation

Editing the Number in the DIRECTORY before Dialing

1. Press the  button. The LCD Screen will display "DIRECTORY".
2. Press the SCROLL UP  or DOWN  button to find the caller.
3. Press the  button to edit the name.
4. Press the SCROLL DOWN  button.

e.g.









5. Press the SCROLLLEFT  or RIGHT  button to move the cursor to the number you want to change.
To erase, press the  button.
To add, use the TELEPHONE KEYPAD  ~  buttons.
6. Press and hold down the DIAL 7  button for a local call, or press and hold down the DIAL 10  button for a local call with area code, or press and hold down the DIAL1+  button for a long distance call.
7. To end your conversation, either press the  button or place the **HANDSET** on the **BASE UNIT**.



NOTE: If you want to save the edited number in the DIRECTORY, follow steps 1 through 5 and then press and hold down the  button.

Caller ID System Operation

Placing Calls from the DIRECTORY

1. Press the  button. The LCD Screen will display "DIRECTORY."
2. Press the SCROLL UP  or DOWN  button to find the record you want to call.
3. Press and hold down the DIAL 7  button for a local call, or press and hold down the DIAL 10  button for a local call with area code, or press and hold down the DIAL 1+  button for a long distance call.
4. To end the call, either press the  button or place the **HANDSET** on the **BASE UNIT**.





Deleting All Records in the DIRECTORY

1. Press the  button. The LCD Screen will display "DIRECTORY."
2. Press and hold down the  button for at least 3 seconds while in DIRECTORY mode.



3. Press the  button to return to STANDBY mode.

Selective Deleting in the DIRECTORY

1. Press the  button. The LCD Screen will display "DIRECTORY."
2. Press the SCROLLUP  or DOWN  button to find the record you want to delete.
3. Press and hold down the  button for at least 3 seconds, then the LCD Screen will display the next record in the DIRECTORY.



4. Press the  button to return to STANDBY mode.





Caller ID System Operation

Function Operation

You can change the settings on the **HANDSET** through the functions menu.

This unit contains the following special functions:

- | | |
|------------------|----------------|
| A. LANGUAGE | F. PBX NUMBER |
| B. SILENT ON/OFF | G. FLASH TIME |
| C. TIME SET | H. PAUSE TIME |
| D. RINGER VOLUME | I. VOICE MAIL |
| E. LCD CONTRAST | J. MSG WAITING |

To access, press the  button at **STANDBY** mode, then press the **TELEPHONE** KEYPAD  ~  button or the **SCROLL UP**  or **DOWN**  button.

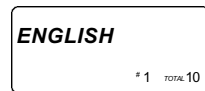

KEYPAD  Button

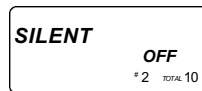

KEYPAD  Button



KEYPAD  Button



KEYPAD  Button



KEYPAD  Button

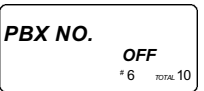

KEYPAD  Button



KEYPAD  Button



KEYPAD  Button



KEYPAD  Button













KEYPAD  Button

Caller ID System Operation









A. Language

This telephone offers English, Spanish, and French languages for your convenience.

1. Press the  button.
2. Press the TELEPHONE KEYPAD  button.
3. Press the  button.
4. Press the SCROLL UP  or DOWN  button to select the language you desire. You can also set the language by pressing the following TELEPHONE KEYPAD buttons;  for English,  for Spanish, or  for French. English is the preset language.
5. Press and hold down the  button.
6. Press the  button to return to STANDBY mode.





B. FIRST RING/Silent On or Off

This telephone will generate the first ring sound even in the BLOCKED CALL mode to indicate that you have an incoming call. To keep the ringer silent in BLOCKED CALL mode, you can turn off the first ring sound.

1. Press the  button.
2. Press the TELEPHONE KEYPAD  button.
3. Press the  button.
4. Press the SCROLL UP  or DOWN  button to select the SILENT ON/OFF setting. You can also press the TELEPHONE KEYPAD buttons;  for ON or  for OFF. SILENT OFF is the preset mode.
5. Press and hold down the  button.
6. Press the  button to return to STANDBY mode.

C. Time Set

Set the date and time.

1. Press the  button.
2. Press the TELEPHONE KEYPAD  button.
3. Press the  button.
4. Use the TELEPHONE KEYPAD button to enter the month, date, hour, and minute. The cursor moves automatically after entering each item. Press the TELEPHONE KEYPAD  for AM setting, or press the TELEPHONE KEYPAD  for PM setting.

Caller ID System Operation

5. Press and hold down the **redial save/pause** button.
6. Press the **menu voice mail** button to return to STANDBY mode.

NOTE: The date and time will automatically set, if you have subscribed to the Caller ID service from your local telephone company.

D. Ringer Volume

This function enables you to adjust the ringer volume to HI, LOW, or OFF as desired.

1. Press the **menu voice mail** button.
2. Press the TELEPHONE KEYPAD **ghi 4** button.
3. Press the **edit** button.
4. Press the SCROLL UP **▲** or DOWN **▼** button to adjust the ringer volume as needed. You can also adjust the ringer volume by pressing the following TELEPHONE KEYPAD buttons; **1** for HI, **abc 2** for LOW, or **def 3** for OFF. HI is the preset ringer volume.
5. Press and hold down the **redial save/pause** button.
6. Press the **menu voice mail** button to go back to STANDBY mode.

E. LCD Contrast

This unit enables you to select 8 brightness levels for the Large LCD Screen.

1. Press the **menu voice mail** button.
2. Press the TELEPHONE KEYPAD **jkl 5** button.
3. Press the **edit** button.
4. Press the SCROLLUP **▲** or DOWN **▼** button to adjust the brightness of the LCD Screen. Level 1 is the preset brightness.
5. Press and hold down the **redial save/pause** button.
6. Press the **menu voice mail** button to go back to STANDBY mode.

F. PBX Number

This unit enables you to preset the PBX number (such as an 8 or 9) while you are using a switchboard system.



1. Press the **menu voice mail** button.
2. Press the TELEPHONE KEYPAD **mno 6** button.
3. Press the **edit** button.

Caller ID System Operation

4. Press the SCROLL UP  or DOWN  button. (OFF is the preset PBX number.)
PBX MODE OFF - set for direct line access.

5. Press and hold down the  button.

6. Press the  button to go back to STANDBY mode.

NOTE: When placing a call by using the DIAL 7 , or the DIAL 10 , or the DIAL 1+  button, this telephone will automatically add the PBX number and a pause time before the dialed telephone numbers.





G. Flash Time

This unit enables you to select the standard FLASH TIME applicable to your calling area. If you are not sure of the FLASH TIME you are using, call your local telephone company.

1. Press the  button.

2. Press the TELEPHONE KEYPAD  button.

3. Press the  button.

4. Press the SCROLLUP  or DOWN  button to select the FLASH TIME. You can also set the FLASH TIME by entering the FLASH TIME number using the TELEPHONE KEYPAD  ~  buttons. The preset FLASH TIME is 600 milliseconds.

5. Press and hold down the  button.

6. Press the  button to go back to STANDBY mode.

H. Pause Time

This unit enables you to adjust the PAUSE TIME when placing a call using a switchboard system or dialing long distance calls.

1. Press the  button.

2. Press the TELEPHONE KEYPAD  button.

3. Press the  button.

4. Press the SCROLL UP  or DOWN  button to adjust the PAUSE TIME. The preset PAUSE TIME is 4 seconds.







5. Press and hold down the  button.

6. Press the  button to return to STANDBY mode.

Caller ID System Operation







I. Voice Mail

This telephone enables you to store the Voice Mail Access Code number in your area. This will automatically connect you to the Voice Mail service provider with one-touch dialing.

1. Press the  button.
2. Press the TELEPHONE KEYPAD  button.
3. Press the  button.
4. Enter the Voice Mail Post Code number by using the TELEPHONE KEYPAD  ~  buttons.
5. Press and hold down the  button.
6. Press the  button to go back to STANDBY mode.

J. MSG Waiting (Message Waiting)

To turn off the Message Waiting LCD Screen indicator.

1. Press the  button.
2. Press the TELEPHONE KEYPAD  button.
3. Press the  button.
4. Press the SCROLL UP  or DOWN  button.
5. Press and hold down the  button.
6. Press the  button to go back to STANDBY mode.

IMPORTANT: The Message Waiting LCD indicator will automatically turn ON, if you have subscribed to Voice Mail message service and if you have Visual Message Indication from your local telephone company.

IMPORTANT
In order to utilize the Caller ID feature, you must
subscribe to Caller ID service from your local
telephone company.

Caller ID System Operation







Telephone Keypad Characters

The TELEPHONE KEYPAD  ~  buttons are used to enter characters when entering names. Press the appropriate TELEPHONE KEYPAD button to get the following characters.





KEYPAD BUTTONS	CHARACTERS
1	SPACE & ' () * . 1
2	A B C 2
3	D E F 3
4	G H I 4
5	J K L 5
6	M N O 6
7	P Q R S 7
8	T U V 8
9	W X Y Z 9
*	*
0	0
#	#

EXAMPLE:

If you want to enter the characters "ACE" on the HANDSET LCD Screen.

1. Press the  button. The LCD Screen will display "DIRECTORY".
2. Press the  button.
3. Press the TELEPHONE KEYPAD  button, "A" will be displayed. Press the SHIFT RIGHT  button to move the cursor to the right to enter the next character (See NOTES below.).
4. Press the TELEPHONE KEYPAD  button three times to display "C".
5. Press the TELEPHONE KEYPAD  button two times to display "E".

NOTES:

1. To enter the next character, press the appropriate button. If, however, the next character is on the same button as the previous character, you will first need to press the SHIFT RIGHT  button. Pressing the SHIFT RIGHT  button a second time will produce a space.
2. If you want to change any character, you can go back to the incorrect character by pressing the SHIFT LEFT  button. To delete the character inside the cursor "■", press the  button.
3. You can store a maximum of 15 characters on the letter icon.
4. You can store a maximum of 16 digits on the number icon.

Answering System Operation

Resetting the Answering System

After connecting your phone, press and hold down the **stop** button for at least 3 seconds. Release the button and the unit will “beep”. Your unit will now reset itself. Then your unit will announce, *Please enter new time and record your announcement*. You can now set the day/time and record your new announcement. See the details in the following paragraphs.

NOTE: If the Answering System stops functioning or is not functioning normally, unplug and then plug the AC ADAPTER into its power source. Then follow the procedure in the preceding paragraph to reset the Answering System.

Setting the Day/Time Stamp

Press and hold down the **set** button until you hear the announcement *Time is off, please enter new time*. Then enter the current day and time.

1. **Day Setting**

Press and hold down the **day** button. Release the button when the desired day is announced.

2. **Hour Setting**

Press and hold down the **hour** button. Release the button when the desired hour is announced.

3. **Minute Setting**

Press and hold down the **min** button. Release the button when the desired minute is announced.

Press the **set** button to confirm the selected day and time. The system will announce the day and time.



You must set the Day and Time in order to have a correct Day/Time stamp at the end of each incoming message. Anytime you have a power failure or power interruption, you must reset the Day and Time.

Answering System Operation

Recording Your Outgoing Messages

Your Answering System provides one PRIMARY MAILBOX and four individual MAILBOXES (1, 2, 3, 4) which can receive their own Incoming Messages (ICM). Before using your Answering System, it is suggested that you record an Outgoing Message (OGM). This is the announcement callers will hear when the system answers a call.

A pre-recorded system announcement *Please record your message after the beep* is available if you choose not to record your own OGM.

A. Recording your OGM in the PRIMARY MAILBOX

1. Press and hold down the **ogm** button to record your message.
2. Begin speaking immediately after you hear, *Please record your announcement after the beep*. Continue to depress the **ogm** button. One second after completing your OGM, release the **ogm** button. Your recorded message will be played after releasing the **ogm** button.

NOTE: Your OGM must be at least 3 seconds and no more than 30 seconds in length.

If you wish to change your OGM, repeat steps 1 through 2.

After recording an OGM, you can choose to use the pre-recorded announcement for your Answering System.

1. Press the **ogm** button, while the OGM is playing, press the **erase** button.
2. After *You have no announcement* is played, the system generated *Please record your message after the beep* will replace the locally recorded Answering System's OGM.

NOTE: To obtain a better sound quality for locally recorded (OGMs and Memos) messages, speak directly into the MICROPHONE from a distance of 9 to 12 inches.

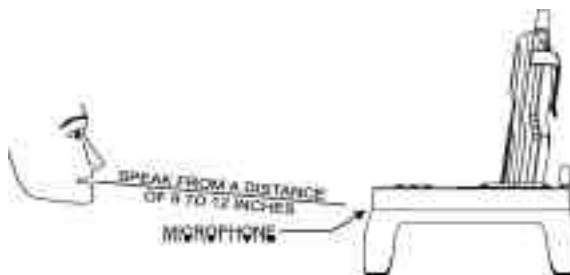

It is recommended that you record an OGM on your PRIMARY MAILBOX instructing a caller to leave an ICM in one of the four mailboxes. If the caller is using a Touchtone telephone, this will enable the caller to record an ICM directly into one of the four mailboxes by dialing "11" for MAILBOX 1, "22" for MAILBOX 2, "33" for MAILBOX 3, or "44" for MAILBOX 4.

Example of a Primary OGM: *Hello, please leave a message after the tone, or if you are using a Touchtone telephone, please Dial 11 for Beth, Dial 22 for Jenny, Dial 33 for Jonathan, or Dial 44 for Esson.*

Answering System Operation

NOTE: To check your OGM, press the **ogm** button. If you did not record an OGM, your Answering System will announce, *You have no announcement.*

B. Recording your OGM to Individual MAILBOX 1, 2, 3 or 4



1. Press a mailbox button, the corresponding MAILBOX LED indicator will blink.
2. Press and hold down the **ogm** button to record your message.
3. Begin speaking immediately after you hear, *Please record your announcement after the beep*. Continue to press the **ogm** button.

One second after completing your OGM, release the **ogm** button. Your recorded message will be played after releasing the **ogm** button.

NOTE: Your OGM must be at least 3 seconds and no more than 30 seconds in length. If you wish to change your OGM, repeat steps 1 through 3.

NOTE: To check your OGM in a mailbox, press a mailbox button and then press the **ogm** button. If you do not have an OGM in a mailbox, it will announce *You have no announcement.* Once a mailbox is activated, its corresponding MAILBOX LED indicator blinks slowly to show that the mailbox is active. If you do not press a button to activate another function within 12 seconds, the Answering System will return to the PRIMARY MAILBOX. You may return to the PRIMARY MAILBOX at anytime by pressing the **stop** button.

Adjusting the Speaker Volume

While the Answering System plays back your message, the speaker volume can be adjusted by pressing the  and  button. The LED Message Display will display the selected volume level:

"0" - Speaker off

"1-8" - Volume from low to high

Turning the Answering System ON/OFF

1. Press the **ans on/off** button to turn ON the Answering System. You will hear the following message, *Answering machine is ON.*
2. Press the **ans on/off** button again to turn OFF the Answering System. You will now hear the following message, *Answering machine is OFF.*

NOTE: Once turned OFF, the Answer function will answer only on the tenth ring, allowing you to turn the Answering System ON from a remote location.

Answering System Operation

Setting to Answer Calls

The ANSWER ON/OFF LED indicator must be ON for the Answering System to answer calls. Depending on the setting of the ANNC/ICM switch, the Answering System will either hang up after your announcement (ANNC) or begin to record your caller's messages (ICM). After the caller leaves an ICM, the time and day will be stamped at the end of each recorded ICM. The ICM is stored in the MEMORY and the LED Message Display shows the total number of ICMs currently stored.

NOTE: ICMs are limited to a maximum of 2 minutes. If the ICM is more than 2 minutes, the system "beeps" twice and hangs up; or if the Answering System's memory runs out, the Answering System announces, *Memory full*, and hangs up.

Setting to Announce Only

During ANNC (Announce) mode, your system answers incoming calls with your recorded announcement but will not record any ICMs.

1. Set the ANNC/ICM select switch to ANNC.
2. Press and hold down the **ogm** button to record your announcement.
3. Begin speaking after you hear, *Please record your announcement after the beep*. Do not release the **ogm** button until you have completed your announcement OGM.

NOTE: Your OGM must be at least 3 seconds and no more than 30 seconds in length.

4. Release the **ogm** button one second after your announcement is completed, and the LED Message Display will show "RD".

NOTE: If you have not recorded an announcement for ANNC mode, even if the switch is set to ANNC mode, the Answering System will automatically operate in ICM mode and will record all ICMs.

Screening Incoming Calls

The Answering System allows you to listen to a caller leaving an ICM. Once the Answering System starts answering a call, press the **talk** button (or pick up any extension telephone on the same line), the Answering System will stop recording and you may converse with your caller.

Message Alert

When the message alert switch is "ON," the unit will generate a "beep" sound every 15 seconds after a new message has been recorded. If you do not want to hear the "beep," set the switch to the OFF position.

Setting Ring Select

To choose the number of times the phone rings before the Answering System responds, set the Ring Select switch to 3R, 5R, or TS (TOLL SAVER).

Set to 3R - System answers call after the third ring.

Set to 5R - System answers call after the fifth ring.

Set to TS - Use "TOLL SAVER" (TS) when you will be checking your system for message from a remote location using long distance services or from a pay phone. The Answering System responds on the third ring only if you have new message waiting. If there are no new messages, the phone will answer after the fifth ring. You can hang up on the fourth ring to avoid paying for the call.

Answering System Operation

Recording a Memo

A. To record a Memo in the PRIMARY MAILBOX

1. Press and hold down the **memo** button to record your Memo.
2. Begin speaking immediately after you hear, *Please record your message after the beep.* Continue to depress the **memo** button. One second after completing your Memo, release the **memo** button. Day and time are automatically stamped at the end of the message.

NOTE: The Answering System advances the message count automatically after the actual message is recorded.

B. To record a Memo in an individual MAILBOX (1, 2, 3, 4)

1. Press a mailbox button, the corresponding MAILBOX LED indicator will blink.
2. Press and hold down the **memo** button to record your Memo.
3. Begin speaking immediately after you hear, *Please record your message after the beep.* Continue to depress the **memo** button. One second after completing your Memo, release the **memo** button. Day and time are automatically stamped at the end of the message.

NOTE: The Answering System advances the message count automatically after the actual message is recorded.

NOTE: To obtain a better sound quality for locally recorded (OGMs and Memos) messages, speak directly into the MICROPHONE from a distance of 9 to 12 inches.

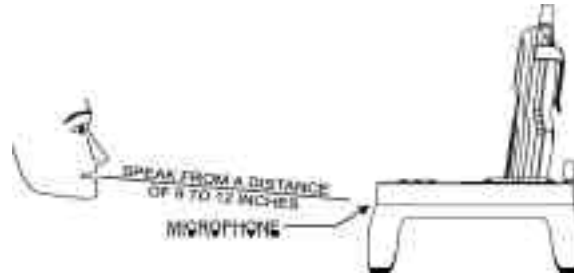

Playing of Messages/Memos

A. To play messages/memos in the PRIMARY MAILBOX

1. Press the **play** button, the system will play all NEW messages/memos.
2. After playing all NEW messages/memos, press the **play** button again, the system will play all of its messages.

Answering System Operation

B. To play messages/memos in an individual MAILBOX (1, 2, 3, 4)

1. Press a mailbox button, the corresponding MAILBOX LED indicator starts to blink.
2. Press the **play** button. The system will play all NEW messages/memos.
3. After playing all NEW messages/memos, press the **play** button again, the system will play all of its messages/memos.

NOTE: When the MAILBOX LED indicators are lit, messages are present.

C. To interrupt a message

1. Press the **stop** button once to pause a message while it is being played, 'PR' will be displayed.
2. Press the **play** button to continue playing the current message.
3. Press the **stop** button twice to end the playing of a message.

D. To repeat a message/memo

1. Press the **rpt** button while playing a message. The system repeats the current message in its entirety.

E. To skip message/memo

1. Press the **skip** button once. The Answering System stops playing, moves to the next message/memo and resumes playback. The system advances one message/memo each time you press the **skip** button.

Saving Messages

The Answering System saves your messages automatically. After playing all of your messages, the Answering System announces, *End of messages* and the total number of messages stored in the memory will be indicated on the LED Message Display.

Answering System Operation

Erasing Messages

A. To erase all of the messages in the PRIMARY MAILBOX

1. Press and hold down the **erase** button until you hear the announcement, *Messages erased, you have no messages.* If you have a new message in the PRIMARY MAILBOX, you will hear, *You have # new messages.*

B. To erase all of the messages in an individual MAILBOX (1, 2, 3, 4)

1. If you want to erase all of the messages in a mailbox, activate the desired mailbox.
2. Press and hold down the **erase** button until you hear the announcement, *Messages erased MAILBOX #, you have no messages.* If you have a new message in the MAILBOX #, you will hear, *You have # new messages.*

C. To erase selected messages/memos

1. While the unwanted message is playing, press the **erase** button. The Answering System announces erasure of the selected message/memo, and the LED Message Display shows the symbol of 'ER.' After the erasure is complete, the numeric order of the remaining messages will be rearranged.

When the Memory is Full

When there is no memory available for additional messages, the Answering System will announce, *Memory full,* but will not save any new messages.

NOTE: When the Answering System memory is full, previously reviewed messages must be deleted so that the system can record new messages.

NOTE: You must enter your Remote Access Code within 10 seconds of activating the Remote Control function to maintain your connection with the Answering System. (Refer to Remote Control Operation on page 35.)

Two -Way Recording

Two-way recording allows you to record your conversation with another caller.

In order to have 2-way recording, you must use the cordless **HANDSET** of the Answering Machine while recording the conversation.

1. During conversation, press a mailbox button (MAILBOX 1, 2, 3, or 4) where you want to record your conversation. The corresponding MAILBOX LED indicator will blink.
2. Press and hold down the **memo** button. The LED Message Display will show "2r" to indicate the RECORDING mode.
3. Release the **memo** button to end your conversation recording.
4. Also you can record on the PRIMARY MAILBOX, just follow steps 2 and 3.

NOTE: Recording two-way conversations may be subject to local, state or federal laws and regulations. Consent of both parties is required when a conversation will be recorded.

Remote Control Operation

Remote Operation through a Tone Telephone

You can use many Answering System features when you are away from home. To protect your privacy, most of the features can be used only after you enter the three-digit Remote Access Code.

Remote Access Codes

The Remote Access Codes are preset at the factory as below. You can use the preset codes or choose your own.

PRIMARY MAILBOX:	999
MAILBOX 1:	555
MAILBOX 2:	666
MAILBOX 3:	777
MAILBOX 4:	888

NOTE: If there is a power failure of the **BASE UNIT**, the Remote Access Codes return to the factory preset codes.

Changing of the Remote Access Codes

All of the digits of the Remote Access Codes are a combination of the numbers 5, 6, 7, 8, 9, and 0.

IMPORTANT: Digits 1, 2, 3, and 4 cannot be used when changing the Remote Access Codes for any mailbox (including the PRIMARY MAILBOX).

1. Press a mailbox button for MAILBOX 1, 2, 3, or 4. For the PRIMARY MAILBOX, follow steps 2 to 6.
2. Press and hold down the **code** button until you hear the announcement, *Please enter new password.*
3. Press and hold down the **1** button. Release the button when you hear the desired first digit of the code.
4. Press and hold down the **2** button. Release the button when you hear the desired second digit of the code.
5. Press and hold down the **min** button. Release the button when you hear the desired third digit of the code.
6. Press the **code** button, the 3-digits you have selected will be announced.
7. If your new Remote Access Code is the same as that of another mailbox, the Answering System will not record your password and will announce, *Please try again.*

Remote Control Operation

Using the Remote Instruction Code

1. Dial your telephone number.
2. Listen to or bypass the OGM in the PRIMARY MAILBOX by entering your Remote Access Code.
3. A “beep” will sound when your Remote Access Code is correctly accepted by your Answering System.
4. If the announcement does not stop, enter the Remote Access Code again.
5. The Answering System will request that you enter the Instruction Code or press “0” for help.
 - A. If you do not know the Instruction Code, press the “0” button immediately. The Answering System will announce the Instruction Codes. Otherwise, if a command is not received by the Answering System within 10 seconds, it will signal 3 “beeps” and hang up.

The following is the Remote Instruction Code Help Menu:

Instruction Codes

To playback announcement press “5.”

To record memo press “6.” (Press “0” for PRIMARY MAILBOX, press “1” for MAILBOX 1, press “2” for MAILBOX 2, press “3” for MAILBOX 3, and press “4” for MAILBOX 4.)

To record announcement press “7.”

To turn answering machine OFF or ON press “8.”

To change mailbox press “* (star).”

To playback message press “2.”

While message playback:

To repeat message press “1.”

To skip message press “3.”

To stop press “4.”

To erase message press “9.”

- B. Press the corresponding number of the Instruction Code you wish to activate. You do not have to listen to the entire Instruction Code Help Menu before giving a command. You may enter the desired Instruction Code Number at any given time.
- C. After accessing the Answering System, you must enter the next command within 10 seconds after the end of each operation. Otherwise, your Answering System will hang up the phone automatically.

Security

Security System

Your cordless telephone uses a digital coding security system to prevent unauthorized use of your telephone line by another nearby cordless telephone. The system has its own identifying signal created by microcomputers in both the **BASE UNIT** and the **HANDSET**.

Security Code

This telephone has an internal security code with 65,536 possible combinations.

Resetting Security Code and Channel Information

Communication between the **HANDSET** and the **BASE UNIT** may not be possible in any of the following situations:

1. After a power failure.
2. After relocating the **BASE UNIT** by disconnecting the AC ADAPTER.
3. After replacing the **HANDSET BATTERY PACK**.

To reset, place the **HANDSET** on the **BASE UNIT** for 2 to 5 seconds.

Multi-Channel Access

Your cordless telephone lets you select a channel from the 40 frequencies available to transmit signals between the **BASE UNIT** and **HANDSET**. When you notice interference from other cordless telephones, change to another channel by pressing the  button on the **HANDSET**.

IMPORTANT

When you hear interference, press the  button to change the operating channel.

Recharging the BATTERY PACK

Battery Type

Use the following type and size of BATTERY PACK:

Cordless Telephone BATTERY PACK
3.6V, 600mAh
U.S. Electronics Inc.
Ni-MH Battery Pack: Model B655

This BATTERY PACK is available through:

U.S. Electronics Service Center
105 Madison Avenue
New York, NY 10016
1-800-825-5208

- NOTES:**
- 1. During a power interruption, the BASE UNIT does not operate, and a phone conversation cannot be made on the HANDSET.**
 - 2. A beep will be heard when the HANDSET is properly positioned in the BASE UNIT CHARGE CRADLE and charging. Securely positioning the HANDSET, KEYPAD face up, in the BASE UNIT will also prevent the HANDSET from falling.**

Recharging the Battery Pack

The nickel metal hydride (Ni-MH) BATTERY PACK in the **HANDSET** can be recharged many times using the built-in charger in the **BASE UNIT**.

When the BATT LOW symbol appears on the LCD Screen, a “beep” sound will be heard every 10 seconds. This indicates that the BATTERY PACK needs to be recharged.

Charge the BATTERY PACK at least once every 90 days of non-use to avoid battery failure. When the BATTERY PACK can no longer be charged, replacement of the BATTERY PACK will be necessary.

The BATTERY PACK used in your telephone may develop a condition known as “MEMORY”. Once subjected to a regular short discharging routine, the BATTERY PACK assumes the discharging pattern it was subjected to. This is known as a “MEMORY” condition which causes rapid discharging thereby shortening the BATTERY PACK charge span. If you believe your BATTERY PACK has developed a “MEMORY” condition, do not charge the **HANDSET** until the BATT LOW symbol appears on the LCD Screen. When the BATT LOW symbol appears on the LCD Screen, charge the **HANDSET** fully for 12 hours.

IMPORTANT

In order to get maximum life from the HANDSET BATTERY PACK, be sure to charge the HANDSET for 12 hours before initial use.

Changing the BATTERY PACK

Changing the Battery Pack

The BATTERY PACK provides power for the **HANDSET** of your cordless telephone.

To Replace BATTERY PACK:

1. Remove the **HANDSET BATTERY COMPARTMENT COVER** by sliding it down.
2. Pull out the **BATTERY PACK PLUG** and remove the **BATTERY PACK**.
3. Plug the new **BATTERY PACK** into the **BATTERY CONNECTOR**.
4. Slide the **HANDSET BATTERY COMPARTMENT COVER** firmly into place in its closed position.
5. Before use, charge the new **BATTERY PACK** for 12 hours.

ATTENTION:

The telephone that you have purchased contains a rechargeable BATTERY PACK. The BATTERY PACK is recyclable. At the end of its useful life, under various state and local laws, it may be illegal to dispose of this BATTERY PACK into the municipal waste stream. Check with your local solid waste officials for details in your area for recycling options or proper disposal.

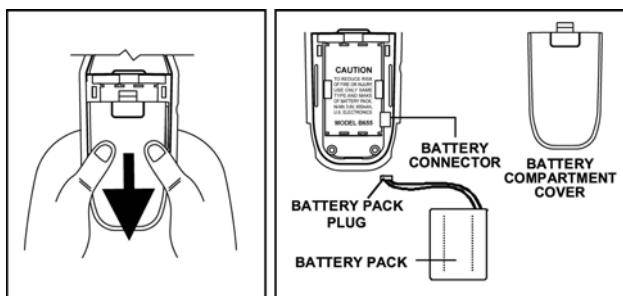

Remove the **HANDSET BATTERY COMPARTMENT COVER** by sliding it down.

IMPORTANT
In order to get maximum life from the **HANDSET BATTERY PACK**, be sure to charge the **HANDSET** for 12 hours before initial use.

Problem Solving

Problem Solving Section

For your assistance, we have listed below a few common problems.

Phone does not work, check the following:

1. **BASE UNIT** is plugged into a power source.
2. **HANDSET** is charged.
3. TONE/PULSE Select switch is in the right position.
4. TELEPHONE LINE CORD is plugged into the TELEPHONE JACK.

Range of phone limited, check the following:

1. **BASE UNIT** is centrally located in your residence.
2. **BASE UNIT** is not located near appliances.

No dial tone, check the following:

1. TELEPHONE LINE CORD plugs are connected to the TELEPHONE JACK and TELEPHONE LINE CONNECTION JACK.
2. **BASE UNIT** is plugged into a power source.
3. If you had a power failure or had unplugged the **BASE UNIT**, replace the **HANDSET** on the **BASE UNIT** for 2 to 5 seconds to reset the system.

Received signal flutters or fades, check the following:

1. BATTERY PACK in the **HANDSET** is fully charged.
2. **HANDSET** is not too far from the **BASE UNIT**.

Interference on reception, check the following:

1. Noise may be picked up from electrical products in the home or electrical storms. Generally, this noise is a minor annoyance and should not be interpreted as a defect in your system. (See Technical Information on page 42.)
2. Choose an alternate channel using the  button on the **HANDSET**.
3. Do not use this telephone within 20 ft. of a microwave oven while it is working, as you may experience interference. This is a normal occurrence with 2.4 GHz phones and should not be interpreted as a defect in the product.

Long Distance L-D-C indicator is not ON when receiving a long distance call, check the following:

1. Your local telephone company can provide the Area Code on an incoming long distance call.

Excess static, check the following:

1. Check to see that the ANTENNA is not touching another metal object.

If after pressing the button, you receive three beeps and no dial tone, check the following:

1. **BASE UNIT** is plugged into a power source.
2. If you had a power failure or had unplugged the **BASE UNIT**, replace the **HANDSET** on the **BASE UNIT** for 2 to 5 seconds to reset the system.

Problem Solving

Answering System does not work, check the following:

1. **BASE UNIT** is plugged into a power source.
2. Reset the system by pressing and holding the **stop** button for at least 3 seconds. Release the button and the unit will “beep”.

Answering System does not answer calls, check the following:

1. ANSWER ON/OFF LED indicator is lit.

Answers calls only after 10 rings, check the following:

1. ANSWER ON/OFF LED indicator is lit.
2. Message Memory is not full.

Does not respond to remote commands, ensure the following:

1. Correct Remote Access Code is entered.
2. ATONE telephone is being used.

Message is incomplete, ensure the following:

1. Message Memory is not full.
2. Caller may be hesitating and pausing for more than 7 seconds.

Answer calls but does not record messages, check the following:

1. ANNC/ICM switch is set to ICM.
2. Memory is not full.
3. Extension telephone was not picked up.

Answering System announces Time is off at the end of each message, check the following:

1. Have you set the Day/Time?
2. Was there a power interruption?

No Sounds on the BASE UNIT:

1. Adjust the volume by using **mute** and **volume** button and make sure the volume level is not “0”.

Reset your cordless telephone:

1. You can reset your unit if the unit is not working properly. Unplug and then plug the AC ADAPTER into its power source, then press and hold down the **stop** button for at least 3 seconds, then release the button and the unit will “beep”. (See detail operations in page 28.)

NOTE: If none of telephones in the house are working, disconnect one set at a time to verify that none of the phones are causing the problem. If you still have a problem after doing this, and your telephone still does not work, please contact your local phone company.

Technical Information

Technical Information

This cordless telephone uses radio frequencies to allow mobility. There are certain difficulties in using radio frequencies with a cordless telephone. While these are normal, the following could affect the operation of your system.

Noise

Electrical pulse noise is present in most homes at one time or another. This noise is most intense during electrical storms. Certain kinds of electrical equipment such as light dimmers, fluorescent bulbs, motors, and fans also generate noise pulses. Because radio frequencies are susceptible to these noise pulses, you may occasionally hear them in your **HANDSET**. Generally they are a minor annoyance and should not be interpreted as a defect in your system.

Range

Because radio frequency is used, the location of the **BASE UNIT** can affect the operating range. Try several locations in your home or office and pick the one that gives you the clearest signal to the **HANDSET**.

Interference

Electronic circuits activate a relay to connect the cordless telephone to your telephone line. These electronic circuits operate in the radio frequency spectrum. While several protection circuits are used to prevent unwanted signals, there may be periods when these unwanted signals enter the **BASE UNIT**. You may hear clicks or hear the relay activate while you are not using the **HANDSET**. If the interference occurs frequently, it can be minimized or eliminated by relocating the **BASE UNIT**. You can check for interference before selecting the final **BASE UNIT** location by plugging in the telephone.

NOTICE:

This cordless telephone uses radio communication between the **HANDSET** and the **BASE UNIT** and may not ensure privacy of communication. Other devices, including another cordless telephone, may interfere with the operation of this cordless telephone or cause noise during operation. Units not containing coded access may be accessed by other radio communication systems. Cordless telephones must not cause interference to any licensed radio service.

IMPORTANT

When you hear interference, press the



button to change the operating

channel.

FCC Requirements

Federal Communications Commission Requirements

This equipment complies with Part 68 of the FCC rules. A label on the **BASE UNIT** of the equipment contains, among other information, the ACTA Product Number and the Ringer Equivalence Number (REN) for this equipment. You must, upon request, provide this information to your telephone company.

The REN is also useful in determining the number of devices that you may connect to your telephone line and still allow all of these devices to ring when your telephone number is called. In most, but not all areas, the sum of the RENs of all devices connected to one line should not exceed five (5.0). To be certain of the number of devices that you may connect to your line, contact your local telephone company.

If your equipment should cause harm to the telephone network, the telephone company may temporarily disconnect your service. If possible, they will notify you in advance that temporary discontinuance of service may be required.

However, when advance written notice is not possible, the telephone company may temporarily discontinue service without notice if such action is necessary under the circumstances. The telephone company may make changes in its communication facilities, equipment, operations, or procedures where such action is reasonably required in the operation of its business and is not inconsistent with the rules and regulations of the Federal Communications Commission.

Do not attempt to repair or modify this equipment.

Warning: Changes or modifications not expressly approved by the party responsible for its compliance could void the user's authority to operate the equipment.

Some cordless telephones operate at frequencies that may cause interference to nearby TVs and VCRs. To minimize or prevent such interference, the **BASE UNIT** of the cordless telephone should not be placed on or near a TV or VCR. If interference is experienced, moving the cordless telephone farther away from the TV or VCR will often reduce or eliminate the interference.

This equipment should not be used on coin telephone lines. Connection to party line service is subject to state tariffs. If trouble is experienced, disconnect this equipment from the telephone line to determine if it is causing the malfunction. If the equipment is determined to be malfunctioning, its use should be discontinued until the problem has been corrected.

IMPORTANT
Placing your BASE UNIT near appliances such as televisions, refrigerators, radios, or microwave ovens may cause interference.

FCC Requirements

Federal Communications Commission Requirements (continued)

NOTE: This equipment has been tested and found to comply with the limits for a Class B digital device, pursuant to Part 15 of the FCC Rules. These limits are designed to provide reasonable protection against harmful interference in a residential installation. This equipment generates, uses, and can radiate radio frequency energy and, if not installed and used in accordance with the instructions, may cause harmful interference to radio communications.

However, there is no guarantee that interference will not occur in a particular installation. If the equipment does cause harmful interference to radio or television reception, which can be determined by turning the equipment off and on, the user is encouraged to try to correct the interference by one or more of the following measures:

- Reorient or relocate the receiving ANTENNA.
- Increase the distance between the equipment and the receiver.
- Connect the equipment into an outlet on a circuit different from that to which the receiver is connected.
- Consult the dealer or an experienced radio/TV technician for help.

This device complies with Part 15 of the FCC Rules. Operation is subjected to the following two conditions:

- (1) this device may not cause harmful interference, and
- (2) this device must accept any interference received including interference that may cause undesired operation.

Warranty

Warranty Information

BellSouth Products

One-Year Limited Warranty

This limited warranty sets forth all **BellSouth Products** responsibilities regarding your telephone. There are no other expressed or implied warranties from **BellSouth Products**.

Warranty Service Provided

If you purchased the telephone new from a retail vendor, **BellSouth Products** warrants the telephone against defects in material and workmanship for a period of one (1) year from the original date of purchase. This warranty is in lieu of all other express warranties. This warranty begins when you purchase the telephone and continues for one (1) year unless you sell or rent the telephone, in which case the warranty stops.

BellSouth Products disclaims any implied warranty, including the warranty of merchantability and the warranty of fitness for a particular purpose, as of the date of 90 days from your original purchase of the telephone. **BellSouth Products** assumes no responsibility for any special, incidental, or consequential damages.

This warranty gives you specific legal rights and you may have other rights which vary from state to state. Some states do not allow the exclusion or limitations of special, incidental or consequential damages, or limitations on how long a warranty lasts, so the above exclusion and limitation may not apply to you.

Warranty Service Not Provided

This warranty does not cover damage resulting from accident, misuse, abuse, improper installation or operation, lack of reasonable care, unauthorized modification, or the affixing of any attachment not provided by **BellSouth Products** with the telephone, and/or loss of parts. This warranty is voided in the event any unauthorized person opens, alters or repairs the telephone.

All **BellSouth Products** equipment being returned for repair must be suitably packaged.

Telephone companies use different types of equipment and offer various types of services to customers. **BellSouth Products** does not warrant that this telephone is compatible with the type of equipment of any particular telephone company or the services provided by it.

Warranty

What To Do for Warranty Service

During the first thirty (30) days, a defective product is eligible for over-the-counter exchange at the retailer from whom it was purchased. After thirty (30) days, the defective product should be returned to the authorized service center. Please allow 2-3 weeks for the return of your telephone product. The shipping address of the authorized service center is:

U.S. Electronics Consumer Center
C/O Southern Bonded Warehouse
7137 Southlake Parkway
Morrow, GA30260

NOTE: A telephone product received which was not made for **BellSouth Products** or which is not defective as determined by our test procedures will not be repaired and will be returned to you C.O.D., freight collect.

To Obtain Warranty Service

- Provide proof of the date of purchase within the package.
- Prepay all shipping costs to the authorized service center.
- Include a return shipping address within the package.

Please retain your sales receipt, the carton, the packing materials, and the printed material. The original carton is the best shipping container for the telephone should you have to return it.

For your reference:

Serial Number _____

Date of Purchase _____

Name of Dealer _____

Customer Service Telephone Number:
U.S.A. & Canada 1-800-210-8950
OUTSIDE THE U.S.A. & Canada CALL 1-212-242-6978

Visit Us on the Web:
www.uselectronics.info

Wall Mounting Template

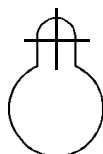

This page serves as a template for attachment of screws to the wall when mounting this telephone on the wall.

1. Cut out this page.
2. Use this template to determine the distance between screws when mounting this phone on the wall. The two cross hairs identify where to attach the screws.

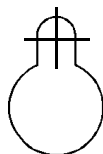

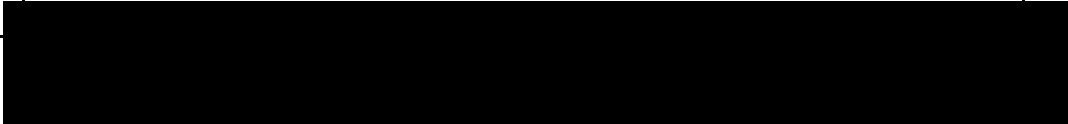

IMPORTANT

In order to get maximum life from the **HANDSET BATTERY PACK**, be sure to charge the **HANDSET** for 12 hours before initial use.

IMPORTANT

Placing your **BASE UNIT** near appliances such as televisions, refrigerators, radios, or microwave ovens may cause interference.

IMPORTANT

When you hear interference, press the  button to change the operating channel.

IMPORTANT

The **AC ADAPTER** must always be plugged into an electrical outlet.

IMPORTANT

If you live in an area which gets frequent thunderstorms, we strongly recommend plugging your **AC ADAPTER** into a surge protector.

IMPORTANT

In order to utilize the **Caller ID** feature, you must subscribe to **Caller ID** service from your local telephone company.

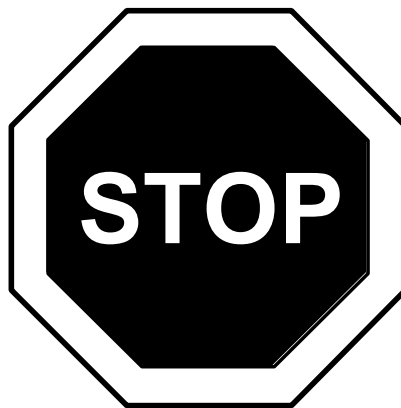

Make certain you receive the best
performance from your telephone.
Read this manual first.



Visit Us on the Web:
www.uselectronics.info
Made in China
CM