

Contents

Safety Instructions	3
Getting Started	5
Desk Mounting	8
Wall Mounting	9
Cordless Telephone Operation	11
Preparing for Use	11
NO LINE Indicator	11
Receiving Calls	11
Placing Calls	12
Headset Feature	13
Redial Feature	13
Caller ID System Operation	14
Caller ID System	14
Viewing Caller Information During Incoming Calls	14
MSG WAITING (Message Waiting)	14
Call Waiting	15
Voice Mail Function	15
C-F (Forwarded Call)	15
L-D-C (Long Distance Call)	15
Caller List	15
Viewing the Caller List	16
Placing a Call From the Caller List	16
Editing the Caller List before Dialing	16
Saving the Name and Number in the Caller List into the DIRECTORY	17
Deleting All Records in the Caller List	17
Selective Deleting in the Caller List	17
Name and Telephone Number DIRECTORY	17
Viewing the DIRECTORY	17
Speed Viewing the DIRECTORY	18
Saving in the DIRECTORY	18
PREFERRED CALLS	18
BLOCKED CALLS	18
Editing a Name and Number in the DIRECTORY	19



Contents

Editing the Number in the DIRECTORY before Dialing	20
Placing Calls from the DIRECTORY	21
Deleting All Records in the DIRECTORY	21
Selective Deleting in the DIRECTORY	21
Function Operation	22
A. Language	23
B. Silent On/Off	23
C. Time Set	23
D. Ringer Volume	24
E. LCD Contrast	24
F. PBX Number	24
G. Flash Time	25
H. Pause Time	25
I. Voice Mail	26
J. MSG Waiting (Message Waiting)	26
Telephone Keypad Characters	27
Security	28
Recharging the Battery Pack	29
Changing the Battery Pack	30
Problem Solving	31
Technical Information	32
FCC Requirements	33
Warranty	35
Wall Mounting Template	41

Safety Instructions

IMPORTANT SAFETY INSTRUCTIONS

To reduce the risk of fire, electric shock and/or injury, always follow these basic safety precautions when using your cordless telephone equipment.

1. Read and understand all instructions.
2. Follow all warnings and instructions marked on the telephone.
3. Unplug this telephone from the wall outlet before cleaning or replacing the BATTERY PACK. Do not use liquid cleaners or aerosol cleaners on the telephone. Use a damp cloth for cleaning.
4. Do not use this telephone near water, for example, near a bath tub, wash bowl, kitchen sink, or laundry tub, in a wet basement, or near a swimming pool.
5. Place this telephone on a stable surface. Serious damage and/or injury may result if the telephone falls.
6. Do not cover the slots and openings on this telephone. This telephone should not be placed near or over a radiator or heat register. This telephone should not be placed in a built-in installation unless proper ventilation is provided.
7. Operate this telephone using the electrical voltage as stated on the **BASE UNIT** of the telephone or in the Owner's Manual. If you are not sure of the voltage in your home, consult your dealer or local power company.
8. Do not place anything on the power cord. Install the telephone where no one will step or trip on the cord.
9. Do not overload wall outlets or extension cords as this can increase the risk of fire or electric shock.
10. Never push objects of any kind through the slots in the telephone. They could touch dangerous voltage points or short out parts that could result in a risk of fire or electric shock. Never spill liquid of any kind on the telephone.
11. To reduce the risk of electric shock, do not disassemble this telephone. Take it to a qualified serviceman when service or repair work is required. Opening or removing covers may expose you to dangerous voltages or other risks. Incorrect reassembly can cause electric shock when the telephone is subsequently used.
12. Unplug this telephone from the wall outlet and consult a qualified service representative in any of the following situations:
 - A. When the power supply cord is frayed or damaged.
 - B. If liquid has been spilled into the telephone.
 - C. If the telephone has been exposed to rain or water.
 - D. If the telephone does not operate normally by following the operating instructions. Adjust only those controls that are covered by the operating instructions. Improper adjustment of other controls may result in damage and will often require extensive work by a qualified technician to restore the telephone to normal operation.



Safety Instructions

- E. If the telephone has been dropped or the case has been damaged.
- F. If the telephone exhibits a distinct change in performance.
- 13. Do not use the telephone to report a gas leak in the vicinity of the leak.
- 14. Never install telephone wiring during a lightning storm.
- 15. Never install telephone jacks in wet locations unless the jack is specifically designed for wet locations.
- 16. Never touch uninsulated telephone wires or terminals unless the telephone line has been disconnected at the network interface.
- 17. Use caution when installing or modifying telephone lines.

Battery Safety

CAUTION:

Danger of explosion if the BATTERYPACK is replaced with incorrect type. Replace only with the same or equivalent type. To reduce the risk of fire or personal injury, read and follow these instructions:

1. Use only the following type and size of BATTERY PACK:
 - Cordless Telephone BATTERY PACK
 - 3.6V, 600mAh
 - U.S. Electronics Inc.
 - Ni-Cd BATTERY PACK: Model B650
 - (See page 29 for ordering information.)
2. Do not dispose of the BATTERYPACK in a fire. The BATTERYPACK may explode. Check with local codes for possible special disposal instructions.
3. Do not open or mutilate the BATTERY PACK. Released electrolyte is corrosive and may cause damage to the eyes or skin. Electrolyte may be toxic if swallowed.
4. Exercise care in handling the BATTERY PACK to prevent shorting the BATTERY PACK with conductive materials such as rings, bracelets, and keys. The BATTERY PACK or conductor may overheat and cause burns.
5. Charge the BATTERY PACK provided with (or identified for use with) this telephone only in accordance with the instructions and limitations specified in this manual.
6. Observe proper polarity orientation between the BATTERY PACK and BATTERY CHARGER.

SAVE THESE INSTRUCTIONS

ATTENTION:

The telephone that you have purchased contains a rechargeable BATTERY PACK. The BATTERYPACK is recyclable. At the end of its useful life, under various state and local laws, it may be illegal to dispose of this BATTERY PACK into the municipal waste stream. Check with your local solid waste officials for details in your area for recycling options or proper disposal.

Getting Started

Connecting Your Phone

This section is a reference guide to the basic functions and operations of your cordless telephone. For more detailed descriptions of the operations and features of this telephone, refer to the Contents on page 1.

1. Carefully remove your cordless telephone from its shipping carton. If there is any visible damage, do not attempt to operate this equipment. Return it to the place of purchase.
2. Check to be sure you have all items that come with this cordless telephone system. You should have a **HANDSET**, **BASE UNIT**, AC ADAPTER, MOUNTING BRACKET, TELEPHONE LINE CORD, SHORT TELEPHONE LINE CORD, BELT CLIP, and an Owner's Manual.



HANDSET



BASE UNIT



MOUNTING BRACKET



BELT CLIP



TELEPHONE LINE CORD



SHORT TELEPHONE LINE CORD



AC ADAPTER



BATTERY PACK

3. Insert the small plug on the end of the AC ADAPTER into the POWER-IN CONNECTION JACK at the back of the **BASE UNIT**.
4. Plug the AC ADAPTER into a 120V AC wall outlet.



USE ONLY WITH CLASS 2 POWER SOURCE 9V DC, 300 mA.

5. Insert one plug of the TELEPHONE LINE CORD into the house TELEPHONE JACK and the other end into the TELEPHONE LINE CONNECTION JACK at the back of the **BASE UNIT**. (If you have an older 4-prong TELEPHONE JACK, you will need an RJ-11C TELEPHONE JACK ADAPTER. This adapter is available at the same place you purchased your telephone.)
6. Raise or reposition the ANTENNA on the **BASE UNIT** for the best reception.
7. We recommend not placing this unit next to appliances. Doing so may cause interference.

Getting Started

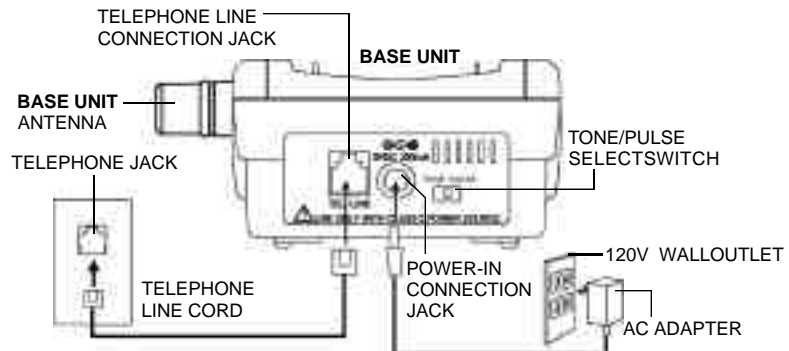

8. Install the BATTERY PACK by plugging it into the BATTERY CONNECTOR inside the BATTERY COMPARTMENT. The **HANDSET** LCD Screen will display "RING: HI".
9. Place the BATTERY PACK inside the BATTERY COMPARTMENT.
10. Slide the **HANDSET** BATTERY COMPARTMENT COVER firmly into place in its closed position.
11. **IMPORTANT: Before initial use, charge the HANDSET for 12 hours. Do not charge the HANDSET with the KEYPAD face down.**
12. TONE/PULSE Select Switch:
 - A. If your home is equipped with a tone dialing system, set the TONE/PULSE Select Switch to the TONE position.
 - B. If you have a rotary dialing system, set the TONE/PULSE Select Switch to the PULSE position.
 - C. If you are unsure which system you have, set the TONE/PULSE Select Switch to the TONE position. Press the **TALK** button on the **HANDSET** and make a call. If the call connects, leave the switch as is; otherwise set to the PULSE position.

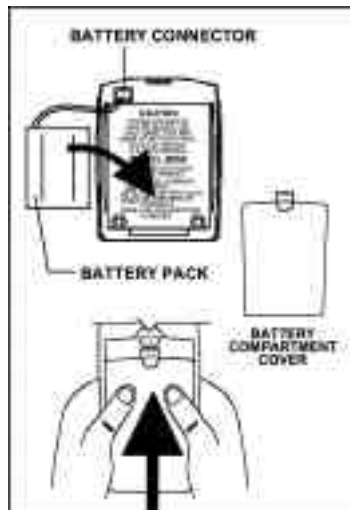

Getting Started

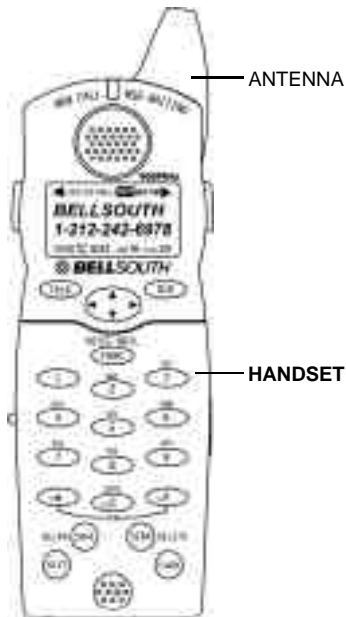

Press the **TALK** button to confirm that you have a dial tone. If you do not get a dial tone, review steps 3 through 12. If you still do not have a dial tone, refer to the Problem Solving section on page 31.

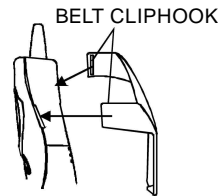

With the back of the **HANDSET** facing up, insert one side of the **BELT CLIP HOOK** into the matching slot at the top side of the **HANDSET**. Press down on the opposite side of the **BELT CLIP** until the other **HOOK** locks into the slot on the side of the **HANDSET**.

13. Set the date and time. (See page 23 for details.)

***You are now ready to use your new
BellSouth Cordless Telephone.***

IMPORTANT
In order to utilize the Caller ID feature, you must
subscribe to Caller ID service from your local
telephone company.

Desk Mounting

Desk Mounting

One of the special features of your telephone is the unique design of the MOUNTING BRACKET which can hold your phone at an angle of 30° when desk mounting.

1. 30° POSITION (See Figure 1):

With the back of the **BASE UNIT** facing up, insert the hooks of the MOUNTING BRACKET (following the arrow direction for the DESK MOUNT) into the matching slots of the **BASE UNIT** (as shown in Figure 2). Then slide the MOUNTING BRACKET into place as indicated by the arrows.



FIGURE 1

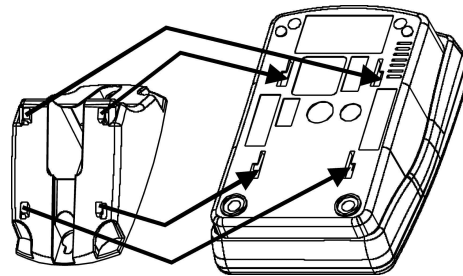

FIGURE 2

IMPORTANT: Attach the MOUNTING BRACKET when using your phone on a desk.

IMPORTANT

Placing your **BASE UNIT** near appliances such as televisions, refrigerators, radios, or microwave ovens may cause interference.

Wall Mounting

Wall Mounting

You may choose to put the **BASE UNIT** of your cordless telephone on a wall.

1. With the back of the **BASE UNIT** facing up, connect the SHORT TELEPHONE LINE CORD to the TELEPHONE LINE CONNECTION JACK.
2. Insert the free end of the SHORT TELEPHONE LINE CORD through the hole of the MOUNTING BRACKET.
3. Insert the hooks of the MOUNTING BRACKET into the matching slots of the **BASE UNIT** (as shown below). Then slide the MOUNTING BRACKET into place as indicated by the arrows. Plug the free end of the SHORT TELEPHONE LINE CORD into the MODULAR WALL JACK.
4. Align the upper keyhole on the MOUNTING BRACKET with the upper stud of the wall plate, so that the opening end of the MOUNTING BRACKET matches the lower stud, then pull the **BASE UNIT** down until it is securely seated.

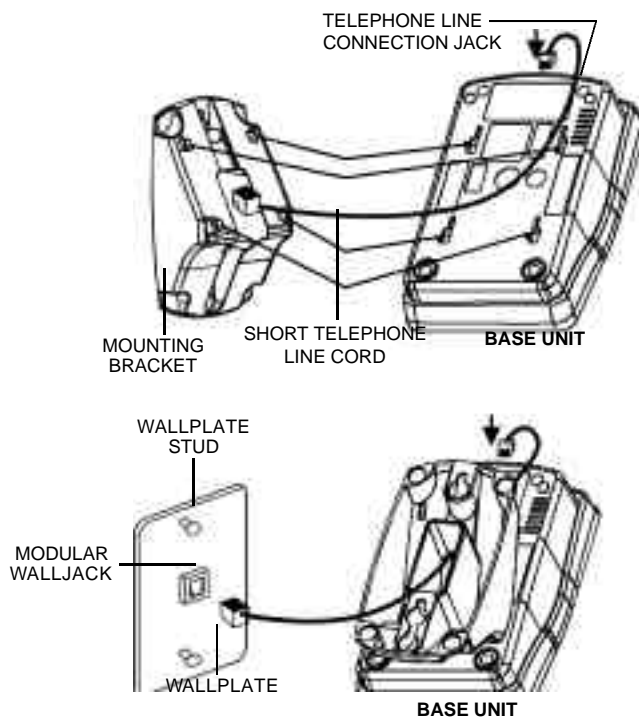

Wall Mounting

5. This cordless telephone has a **HANDSET RETAINER TAB** located on the **BASE UNIT** and a **RETAINER TAB NOTCH** located on the back of the **HANDSET** to secure the **HANDSET** in the **CHARGE CRADLE** when wall mounting.

1. Pull out the **HANDSET RETAINER TAB** using a finger tip or a small flat tool.

(See Figure 1)

2. Place the **HANDSET** in the **CHARGE CRADLE** with its LCD Screen facing you.

(See Figure 2)



FIGURE 1

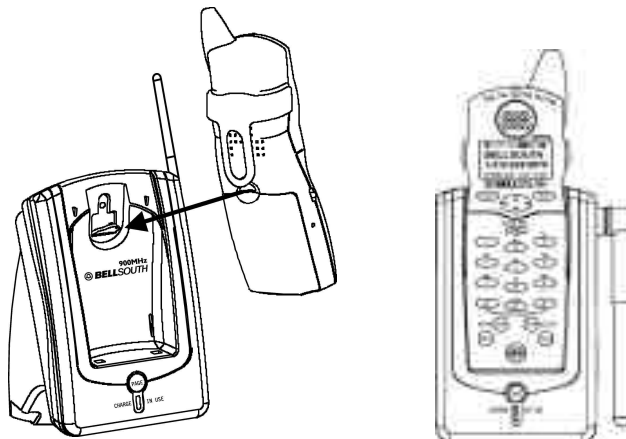

FIGURE 2

IMPORTANT: A "beep" will be heard when the **HANDSET** is properly positioned in the **BASE UNIT CHARGE CRADLE** and charging. Securely positioning the **HANDSET** in the **BASE UNIT** will also prevent the **HANDSET** from falling.

Cordless Telephone Operation

Preparing for Use

Before you can use your cordless telephone, you must charge the **HANDSET** for 12 hours. Failure to do so will require recharging of the **BATTERY PACK** more often.

1. Place the **HANDSET** on the **BASE UNIT** for 12 hours.
2. After 12 hours, remove the **HANDSET** from the **BASE UNIT**.
3. Raise or reposition the **BASE UNIT ANTENNA** for best reception.

Before you can use your cordless telephone, you must charge the HANDSET for 12 hours. Failure to do so will require more frequent charging of the BATTERY PACK. See page 29 for more information on the BATTERY PACK.

NOTE:

Depending on the frequency of use, once the **HANDSET** is fully charged, it remains functional for approximately 4 hours of continuous use and approximately 5 days when the **HANDSET** is off the **BASE UNIT** in **STANDBY** mode.

NO LINE Indicator

This telephone checks for an active TELEPHONE LINE connection. If "NO LINE" appears on the LCD Screen, when the **HANDSET** is in **STANDBY** mode, no calls can be made or received from this telephone. Check that the TELEPHONE LINE CORD plugs are connected to the wall TELEPHONE JACK and the **BASE UNIT TELEPHONE LINE CONNECTION JACK**. If "NO LINE" continues to be displayed, check that the other phones in the house are working. If none of the phones work, contact your local phone company.



Receiving Calls

1. When the phone rings, lift the **HANDSET** and press the **TALK** button. The **HANDSET** LCD Screen will display "CALLS" and "TALKING", and the **BASE UNIT IN USE** LED indicator will light up.
2. Start your conversation.
3. To end your conversation, either press the **TALK** button or place the **HANDSET** on the **BASE UNIT**. If you place the **HANDSET** on the **BASE UNIT CHARGE CRADLE**, you activate the automatic **STANDBY** feature.

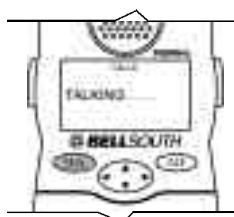

Cordless Telephone Operation

NOTE:

1. The Call Timer will start to count once you press the **TALK** button.
2. The LCD Screen emits light for 5 seconds every time you press any buttons on the **HANDSET**.
3. When "CALLS" appears on the LCD Screen, it means that the **HANDSET** is OFF-HOOK (connected to the telephone line).

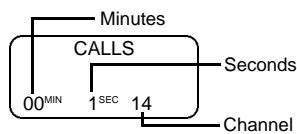

Placing Calls

1. Press the **TALK** button, the Call Timer starts to count. The **HANDSET** LCD Screen will display "CALLS", and "TALKING", and the **BASE UNIT** IN USE LED indicator will light up.
2. Listen for a dial tone.
3. Dial the phone number.
4. When you have finished with your call, press the **TALK** button again or place the **HANDSET** on the **BASE UNIT**.

OR

1. Dial the phone number.
2. Press and hold down the DIAL 7 ***** or the DIAL 10 **OPER 0** or the DIAL 1+ **#** button. The **BASE UNIT** IN USE LED indicator will light up.
3. When you have finished with your call, press the **TALK** button again or place the **HANDSET** on the **BASE UNIT**.

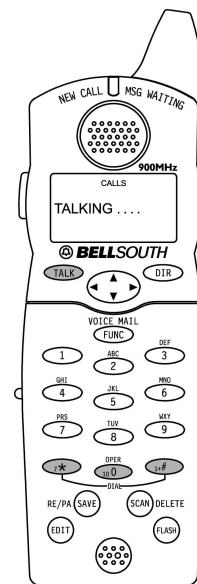

IMPORTANT
 In order to utilize the Caller ID feature, you must subscribe to Caller ID service from your local telephone company.

Cordless Telephone Operation

Headset Feature

Your telephone can utilize a headset (not included) to be connected to your **HANDSET** for you to enjoy hands-free communication. Pull out the **HEADSET JACK COVER** then insert the small plug at the end of the headset into the **HEADSETJACK** at the right side of the **HANDSET**. Follow the procedures discussed in "Receiving Calls" and "Placing Calls" to receive and place a call.

NOTE: When you plug the headset plug into the **HEADSET JACK** it automatically mutes the **MICROPHONE** and **SPEAKER** of the **HANDSET**. Unplug the headset to return the **HANDSET** to normal use.

Headsets are available at most retail outlets that sell telephone equipment. The **HEADSET JACK** is compatible with 2.5mm headset plugs only.

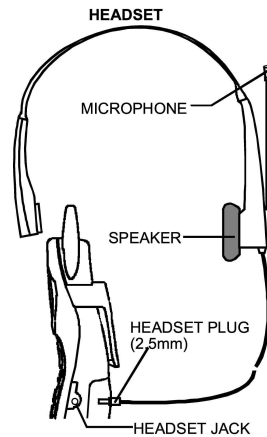

Redial Feature

1. If you get a busy tone, press the **TALK** button or place the **HANDSET** on the **BASE UNIT** to hang up.
2. Later, press the **TALK** button again.
3. Listen for a dial tone.
4. Press the **RE/PA SAVE** button. This will automatically redial the last telephone number you called in TALK mode.
5. When you have finished with your call, press the **TALK** button again (the **BASE UNIT IN USE LED** indicator will turn off) or place the **HANDSET** on the **BASE UNIT**.

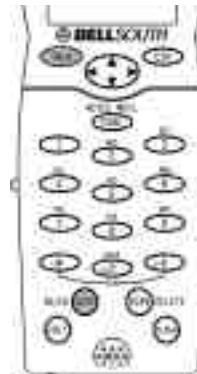

NOTE:

If you are too far away from the **BASE UNIT**, the **HANDSET** emits "beep" sounds to warn you that the background noise level is too high for proper communication between the **HANDSET** and the **BASE UNIT**. When you hear this sound, you should move closer to the **BASE UNIT** to reduce the noise level. Otherwise, the call will automatically cut off.

Caller ID System Operation

Caller ID System

This telephone automatically displays an incoming caller's name and telephone number together with the date and time of the call. It records up to 80 calls and stores the data in Memory.

IMPORTANT: You must subscribe to the Caller ID service from your local telephone company to utilize this feature.

Viewing Caller Information During Incoming Calls

1. When there is an incoming call, the name and the telephone number of the caller will automatically appear after the second ring. Press the SHIFTRIGHT  button to view a name of more than 11 characters.

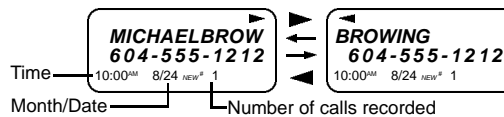

OR

Caller's telephone number will appear if the caller's name is not available.

OR

"OUT OF AREA" will appear if the origin of the incoming call does not support the Caller ID system.

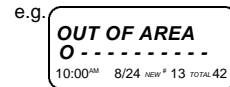

OR

"UNKNOWN" will appear if the origin of the incoming call has no name and does not support the Caller ID system.

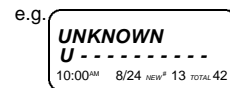

OR

"PRIVATE" and/or "P-----" will appear if the caller's name and/or telephone number is blocked.

OR

"DATAERROR" will appear if wrong data was received from the telephone line.

OR

The name stored in the DIRECTORY will appear for an incoming call with matching telephone numbers.

MSG WAITING (Message Waiting)

The MSG WAITING GREEN LED indicator will blink when there is a message for you from your telephone company if you have subscribed to Voice Mail message service and if you have requested Visual Message Indication from your local telephone company. "MSG WAITING" will appear on the LCD Screen in STANDBY mode. (To remove the MESSAGE WAITING indicator, see page 26 for detail.)

Caller ID System Operation

Call Waiting

When you subscribe to a Call Waiting service from your local telephone company, this telephone will display the name and number of the second caller while you are having a conversation with your first caller.

1. When you are having a conversation, this telephone will automatically display the name and number of the second caller. The name will blink.
2. Press the **FLASH** button to answer the second caller. The first caller's name and number will be displayed. The name will blink.
3. When you have finished, press the **FLASH** button to continue your conversation with the first caller. If you do not want to interrupt your phone conversation with the first caller, you can advise the second caller to leave a Voice Mail message instead.

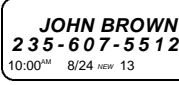
e.g. 
1st Caller

e.g. 
2nd Caller

Voice Mail Function

When there is a Voice Mail message for you, this telephone detects a Stutter Dial Tone (if applicable) and the "MSG" icon on the LCD Screen and the MESSAGE WAITING LED indicator will blink.

1. To access your Voice Mail message, press the **TALK** button.
2. After you hear a dial tone, press the **FUNC VOICE MAIL** button. This will automatically dial the Voice Mail Post Code in your area and connect you to the Voice Mail service provider.

NOTE: You must store the Voice Mail Post Code number by using the VOICE MAIL function on page 26. You can also call your Voice Mail service provider by dialing the Voice Mail Access Code number after pressing the **TALK** button.

C-F (Forwarded Call)

Appears on the upper left hand side of the LCD Screen, when the incoming call has been assigned to your telephone number.

L-D-C (Long Distance Call)

Appears on the upper left hand side of the LCD Screen, when the incoming call is a long distance call and the service is provided by your local telephone company.



Caller List

Records call information for up to 80 incoming calls such as caller's name and telephone number together with the date and time of the call. After recording a new incoming call, the NEW CALL indicator will blink and the LCD Screen will display:

 No. of new calls
Maximum calls= 80

Caller ID System Operation



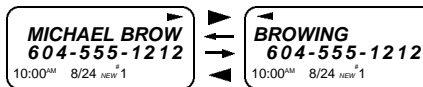

Viewing the Caller List

1. Press the SCROLL DOWN  button to view the latest Caller ID record, or press the SCROLLUP  button to view the first Caller ID record, press the SHIFT RIGHT  button if the name has more than 11 characters.



2. Press the **DIR** button to go back to STANDBYmode. (If no active buttons are pressed for 20 seconds or you have viewed the last Caller ID record in the Caller's List, the LCD Screen will automatically return to STANDBYmode.)









Placing a Call from the Caller List

1. With the **HANDSET** in STANDBYmode, press the SCROLLDOWN  button to select from the latest Caller ID record, or press the SCROLLUP  button to select from the first Caller ID record.
2. Press and hold down the DIAL 7  button for a local call, or the DIAL 10  button for a local call with area code, or the DIAL 1+  button for a long distance call.
3. To end your conversation, either press the **TALK** button or place the **HANDSET** on the **BASE UNIT**.

To place a call from the Caller List in TALK mode, press the **TALK** button, then follow steps 1 through 3.

NOTE: You can edit the number before dialing, but you can not SAVE any changes in the Caller List.

Editing the Caller List before Dialing

1. Press the SCROLLUP  or DOWN  button to find the Caller ID record.
2. Press the **EDIT** button.
3. Move the cursor by pressing the SHIFT LEFT  or RIGHT  button to the digit you want to change. To erase digits, press the **DELETE SCAN** button. To add digits, use the TELEPHONE KEYPAD  ~  buttons.
4. Press and hold down the DIAL 7  button for a local call, or the DIAL 10  button for a local call with area code, or the DIAL 1 +  button for a long distance call.
5. To end your conversation, either press the **TALK** button or place the **HANDSET** on the **BASE UNIT**.

To save the edited record from the Caller List, follow steps 1 through 3 then press and hold down the **RE/PA SAVE** button.

Caller ID System Operation

Saving the Name and Number in the Caller List into the DIRECTORY

1. Press the SCROLLUP ▲ or DOWN ▼ button to find the Caller ID record.
2. Press and hold down the RE/PA SAVE button. The LCD Screen will show "SAVED".

NOTE: It is not advisable to save a telephone number without the corresponding name. This will lead to improper display on PRIVATE and OUTOF AREAcalls.

Deleting All Records in the Caller List

1. Press and hold down the DELETE SCAN button for at least 3 seconds while in STANDBYmode.
2. The LCD Screen will automatically return to STANDBYmode.



Selective Deleting in the Caller List

1. Press the SCROLLUP ▲ or DOWN ▼ button to find the Caller ID record while in STANDBYmode.
2. Press and hold down the DELETE SCAN button for at least 3 seconds, then the LCD Screen will display the next Caller ID record in the CALLER LIST.
3. Press the DIR button to return to STANDBY mode.



Name and Telephone Number DIRECTORY

This DIRECTORY lets you scroll through the list to find the record you need for one touch dialing. You can store up to 40 names and telephone numbers in the memory.

Viewing the DIRECTORY

1. Press the DIR button.

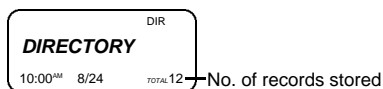

2. Press the SCROLL UP ▲ or DOWN ▼ button to find the record you wish to view, press the SHIFT RIGHT ► button to view a name or telephone number of more than 11 characters.

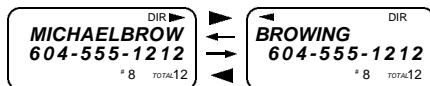

NOTE: To exit the DIRECTORY List at anytime, press the DIR button.









Caller ID System Operation

Speed Viewing the DIRECTORY

1. Press the **DIR** button.
2. Enter the first letter of a name. (See Page 27 for detail of entering a letter.)
3. Press the SCROLL UP  button to view all names with the same first letter.

Saving in the DIRECTORY

1. Press the **DIR** button.
2. Press the **EDIT** button.
3. Use the TELEPHONE KEYPAD  ~  buttons to enter the name, (see page 27 for detail) you can store up to 15 characters. To move the cursor to the right, create a space, or to enter a new letter, press the SHIFTRIGHT  button.
4. Press the SCROLLDOWN  button once.
5. Enter the telephone number using the TELEPHONE KEYPAD  ~  buttons. You can store up to 16 digits.
6. Press and hold down the  button.
7. Press the **DIR** button to go back to STANDBY mode.

(If no active buttons are pressed for 20 seconds, the LCD Screen will automatically return to STANDBY mode.)

NOTES: 1. It will not save a duplicate telephone number or a name without the corresponding telephone number in the DIRECTORY.

2. To delete a character or number inside the cursor, press the  button.

PREFERRED CALLS

You can assign stored numbers a PREFERRED CALL status which will generate a special ringer sound at the start of the second ring to any welcome caller in the DIRECTORY.

When you are saving the name and number into the DIRECTORY, add a “#” symbol at the beginning of the name by pressing the  button.

BLOCKED CALLS

You can assign stored numbers a BLOCKED CALL status which will disable the ringer sound after the second ring to any caller in the DIRECTORY.

When you are saving the name and number into the DIRECTORY, add an “*” symbol at the beginning of the name by pressing the  button.

Caller ID System Operation

Editing a Name and Number in the DIRECTORY











1. Press the **DIR** button.
2. Press the SCROLLUP  or DOWN  button to find the record you want to edit.



3. Press the **EDIT** button to edit the name, and the cursor will blink over the first character.



cursor is blinking

4. Press the SCROLLLEFT  or RIGHT  button to move the cursor to the letter or number you want to change. To erase, press the **DELETE SCAN** button. To add, use the TELEPHONE KEYPAD  ~  buttons. (See page 27 for details.)
5. Press the SCROLLUP  or DOWN  button to edit the number.
6. Press the SCROLLLEFT  or RIGHT  button to move the cursor to the number you want to change. To erase, press the **DELETE SCAN** button. To add, use the TELEPHONE KEYPAD  ~  buttons. (See page 27 for details.)



cursor is blinking



7. Press and hold down the **RE/PA SAVE** button to confirm.

IMPORTANT: It is not advisable to save a telephone number without the corresponding name in the DIRECTORY. This will lead to improper displays on PRIVATE and OUTOF AREA calls.

NOTE: When no active buttons are pressed for 20 seconds, the LCD Screen will automatically return to STANDBY mode.

Caller ID System Operation

Editing the Number in the DIRECTORY before Dialing

1. Press the **DIR** button.
2. Press the SCROLLUP  or DOWN  button to find the caller.
3. Press the **EDIT** button to edit the name.
4. Press the SCROLLDOWN  button.

e.g.



5. Press the SCROLLLEFT  or RIGHT  button to move the cursor to the number you want to change.

To erase, press the **DELETE SCAN** button.





To add, use the TELEPHONE KEYPAD **10 OPER 0** ~ **WXY 9** buttons.

6. Press and hold down the DIAL 7  button for a local call, or press and hold down the DIAL 10 **10 OPER 0** button for a local call with area code, or press and hold down the DIAL 1+ **1+ #** button for a long distance call.
7. To end your conversation, either press the **TALK** button or place the **HANDSET** on the **BASE UNIT**.

NOTE: If you want to save the edited number in the DIRECTORY, follow steps 1 through 5 and then press and hold down the **RE/PA SAVE** button.

Caller ID System Operation

Placing Calls from the DIRECTORY

1. Press the **DIR** button.
2. Press the SCROLLUP  or DOWN  button to find the record you want to call.
3. Press and hold down the DIAL 7  button for a local call, or press and hold down the DIAL 10  button for a local call with area code, or press and hold down the DIAL1+  button for a long distance call.
4. To end the call, either press the **TALK** button or place the **HANDSET** on the **BASE UNIT**.



Deleting All Records in the DIRECTORY

1. Press the **DIR** button.
2. Press and hold down the  button for at least 3 seconds while in DIRECTORY mode.



3. Press the **DIR** button to return to STANDBYmode.

Selective Deleting in the DIRECTORY

1. Press the **DIR** button.
2. Press the SCROLLUP  or DOWN  button to find the record you want to delete.
3. Press and hold down the  button for at least 3 seconds, then the LCD Screen will display the next record in the DIRECTORY.



4. Press the **DIR** button to return to STANDBYmode.

Caller ID System Operation

Function Operation

You can change the settings on the **HANDSET** through the functions menu.

This unit contains the following special functions:

- A. LANGUAGE
- B. SILENT ON/OFF
- C. TIME SET
- D. RINGER VOLUME
- E. LCD CONTRAST
- F. PBX NUMBER
- G. FLASH TIME
- H. PAUSE TIME
- I. VOICE MAIL
- J. MSG WAITING

To access, press the **FUNC VOICE MAIL** button at **STANDBY** mode, then press the **TELEPHONE** KEYPAD **10 OPER 0** ~ **WXYZ 9** button or the **SCROLLUP** **▲** or **DOWN** **▼** button.



KEYPAD **1** Button



KEYPAD **ABC 2** Button



KEYPAD **DEF 3** Button



KEYPAD **GHI 4** Button



KEYPAD **JKL 5** Button

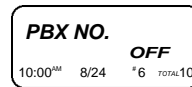

KEYPAD **MNO 6** Button



KEYPAD **PRS 7** Button



KEYPAD **TUV 8** Button



KEYPAD **WXYZ 9** Button

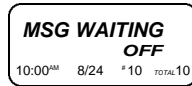

KEYPAD **10 OPER 0** Button

Caller ID System Operation

A. Language

This telephone offers English, Spanish, and French languages for your convenience.

1. Press the **FUNC VOICE MAIL** button.
2. Press the TELEPHONE KEYPAD **1** button.
3. Press the **EDIT** button.
4. Press the SCROLL UP **▲** or DOWN **▼** button to select the language you desire. You can also set the language by pressing the following TELEPHONE KEYPAD buttons; **1** for English, **ABC 2** for Spanish, or **DEF 3** for French. English is the preset language.
5. Press and hold down the **RE/PA SAVE** button.
6. Press the **FUNC VOICE MAIL** button to return to STANDBYmode.

B. Silent On/Off

This telephone will generate the first ring sound even in the BLOCKED CALL mode to indicate that you have an incoming call. To keep the ringer silent in BLOCKED CALLmode, you can turn off the first ring sound.

1. Press the **FUNC VOICE MAIL** button.
2. Press the TELEPHONE KEYPAD **ABC 2** button.
3. Press the **EDIT** button.
4. Press the SCROLL UP **▲** or DOWN **▼** button to select the SILENT ON/OFF setting. You can also press the TELEPHONE KEYPAD buttons; **1** for ON or **ABC 2** for OFF. SILENTOFF is the preset mode.
5. Press and hold down the **RE/PA SAVE** button.
6. Press the **FUNC VOICE MAIL** button to return to STANDBYmode.

C. Time Set

Set the date and time.

1. Press the **FUNC VOICE MAIL** button.
2. Press the TELEPHONE KEYPAD **DEF 3** button.
3. Press the **EDIT** button.
4. Use the TELEPHONE KEYPAD button to enter the month, date, hour, and minute. The cursor moves automatically after entering each item. Press the TELEPHONE KEYPAD **1** for AM setting, or press the TELEPHONE KEYPAD **ABC 2** for PM setting.

Caller ID System Operation

5. Press and hold down the **RE/PA SAVE** button.
6. Press the **FUNC VOICE MAIL** button to return to STANDBY mode.

NOTE: The date and time will automatically set, if you have subscribed to the Caller ID service from your local telephone company.

D. Ringer Volume

This function enables you to adjust the ringer volume from HI, LOW, and OFF as desired.

1. Press the **FUNC VOICE MAIL** button.
2. Press the TELEPHONE KEYPAD **GHI 4** button.
3. Press the **EDIT** button.
4. Press the SCROLLUP **▲** or DOWN **▼** button to adjust the ringer volume suitable for your convenience. You can also adjust the ringer volume by pressing the following TELEPHONE KEYPAD buttons; **1** for HI, **ABC 2** for LOW, or **DEF 3** for OFF. HI is the preset ringer volume.
5. Press and hold down the **RE/PA SAVE** button.
6. Press the **FUNC VOICE MAIL** button to go back to STANDBY mode.

E. LCD Contrast

This unit enables you to select 8 brightness levels for the Large LCD Screen.

1. Press the **FUNC VOICE MAIL** button.
2. Press the TELEPHONE KEYPAD **JKL 5** button.
3. Press the **EDIT** button.
4. Press the SCROLLUP **▲** or DOWN **▼** button to adjust the brightness of the LCD Screen. Level 5 is the preset brightness.
5. Press and hold down the **RE/PA SAVE** button.
6. Press the **FUNC VOICE MAIL** button to go back to STANDBY mode.

F. PBX Number

This unit enables you to preset the PBX number (such as an 8 or 9) while you are using a switchboard system.

1. Press the **FUNC VOICE MAIL** button.
2. Press the TELEPHONE KEYPAD **MNO 6** button.
3. Press the **EDIT** button.

Caller ID System Operation

4. Press the SCROLLUP ▲ or DOWN ▼ button. (OFF is the preset PBX number.)
PBX MODE OFF - set for direct line access.

5. Press and hold down the RE/PA SAVE button.

6. Press the FUNC VOICE MAIL button to go back to STANDBY mode.

NOTE: When placing a call by using the DIAL 7 * , or the DIAL 10 OPER 0 , or the DIAL 1+ # button, this telephone will automatically add the PBX number and a pause time before the dialed telephone numbers.

G. Flash Time

This unit enables you to select the standard FLASH TIME applicable to your calling area. If you are not sure of the FLASH TIME you are using, call your local telephone company.

1. Press the FUNC VOICE MAIL button.

2. Press the TELEPHONE KEYPAD PRS 7 button.

3. Press the EDIT button.

4. Press the SCROLLUP ▲ or DOWN ▼ button to select the FLASH TIME. You can also set the FLASH TIME by entering the FLASH TIME number using the TELEPHONE KEYPAD OPER 0 ~ WXY 9 buttons. The preset FLASH TIME is 600 milliseconds.

5. Press and hold down the RE/PA SAVE button.

6. Press the FUNC VOICE MAIL button to go back to STANDBY mode.

H. Pause Time

This unit enables you to adjust the PAUSE TIME when placing a call using a switchboard system or dialing long distance calls.

1. Press the FUNC VOICE MAIL button.

2. Press the TELEPHONE KEYPAD TUV 8 button.

3. Press the EDIT button.

4. Press the SCROLL UP ▲ or DOWN ▼ button to adjust the pausing time. The preset pause time is 4 seconds.

5. Press and hold down the RE/PA SAVE button.

6. Press the FUNC VOICE MAIL button to return to STANDBY mode.

Caller ID System Operation

I. Voice Mail

This telephone enables you to store the Voice Mail Access Code number in your area. This will automatically connect you to the Voice Mail service provider with one-touch dialing.

1. Press the **FUNC VOICE MAIL** button.
2. Press the TELEPHONE KEYPAD **wxy 9** button.
3. Press the **EDIT** button.
4. Enter the Voice Mail Post Code number by using the TELEPHONE KEYPAD **10 OPER 0** ~ **wxy 9** buttons.
5. Press and hold down the **RE/PA SAVE** button.
6. Press the **FUNC VOICE MAIL** button to go back to STANDBYmode.

J. MSG Waiting (Message Waiting)

To turn off the Message Waiting LCD Screen indicator.

1. Press the **FUNC VOICE MAIL** button.
2. Press the TELEPHONE KEYPAD **10 OPER 0** button.
3. Press the **EDIT** button.
4. Press the SCROLL UP **▲** or DOWN **▼** button.
5. Press and hold down the **RE/PA SAVE** button.
6. Press the **FUNC VOICE MAIL** button to go back to STANDBYmode.

IMPORTANT: The Message Waiting LCD indicator will automatically turn ON, if you have subscribed to Voice Mail message service and if you have Visual Message Indication from your local telephone company.

IMPORTANT

In order to utilize the Caller ID feature, you must subscribe to Caller ID service from your local telephone company.

Caller ID System Operation







Telephone Keypad Characters

The TELEPHONE KEYPAD  ~  buttons are used to enter characters when entering names. Press the appropriate TELEPHONE KEYPAD button to get the following characters.





KEYPAD BUTTONS	CHARACTERS
1	SPACE &'(') * . 1
2	A B C 2
3	D E F 3
4	G H I 4
5	J K L 5
6	M N O 6
7	P Q R S 7
8	T U V 8
9	W X Y Z 9
*	*
0	0
#	#

EXAMPLE:

If you want to enter the characters "ACE" on the HANDSETLCD Screen.

1. Press the  button.
2. Press the  button.
3. Press the TELEPHONE KEYPAD  button, "A" will be displayed. Press the SHIFT RIGHT  button to move the cursor to the right to enter the next character (See NOTES below.).
4. Press the TELEPHONE KEYPAD  button three times to display "C".
5. Press the TELEPHONE KEYPAD  button two times to display "E".

NOTES:

1. To enter the next character, press the appropriate button. If, however, the next character is on the same button as the previous character, you will first need to press the SHIFTRIGHT  button. Pressing the SHIFT RIGHT  button a second time will produce a space.
2. If you want to change any character, you can go back to the incorrect character by pressing the SHIFT LEFT  button. To delete the character inside the cursor "■",press the  button.
3. You can store a maximum of 15 characters on the letter icon.
4. You can store a maximum of 16 digits on the number icon.