

INSTALLATION MANUAL

HIGH EFFICIENCY SEALED COMBUSTION DRUM HEAT EXCHANGER SERIES

MODEL: DFAA/DFAH
**(Oil and Gas Conversion Burner/
Single Stage Downflow Only)**

66 - 84 MBH INPUT
(19.34 - 24.62 KW) INPUT



For Installation In:

1. Manufactured (Mobile) Homes
2. Recreational Vehicles & Park Models
3. Modular Homes & Buildings

LIST OF SECTIONS

SAFETY	1	SAFETY CONTROLS	22
DUCTWORK	5	START-UP AND ADJUSTMENTS	23
FILTERS	10	WIRING DIAGRAM - OIL-FIRED FURNACE	27
OIL PIPING	11	GAS GUN BURNER	29
ELECTRICAL POWER	13	START-UP AND ADJUSTMENTS	33
VENT/COMBUSTION AIR SYSTEM	14	WIRING DIAGRAM - GAS CONVERSION BURNER	38

LIST OF FIGURES

Label Location	4	Wiring for Blend Air Accessory	14
Dimensions	5	Elbow Assembly	15
Air Distribution Systems	7	Combustion Air Inlet Pipe	16
Closet To Door Clearance - 6" or Greater	7	Combustion Air Inlet Pipe Alternate	16
Furnace To Closet Door Clearance - 1" To 6"	7	Flue Shield Installation	16
Furnace To Closet Door Clearance - Less Than 1"	7	Roof Jack Attachment to Furnace	16
Duct Connector Dimensions	8	Standard Roof Jack	18
Recommended Floor Cut-out	8	Roof Jack With Removable Crowns	19
Duct Connector Depth	8	Installing Roof Jack Extension	20
Duct Connector Screw Attachment	8	Ceiling Ring	20
Duct Connector Tab Attachment	9	Home Layout	21
Anti-Backflow Damper	9	Electrode Settings	23
Installation of Furnace	9	Oil Pump	24
Floor Installation	10	Wiring Diagram for DFAA - Oil-Fired Furnace	27
Furnace Air Filters	11	Wiring Diagram for DFAH - Oil Furnace	28
Oil Pump	12	Gas Piping	29
One-Pipe System	13	Manual Shut-off Valve/Gas Piping	30
Two-Pipe System	13	Proper Piping Practice	30
Solenoid Wiring	13	Gas Valve	35
Line Wiring Connections	14	Reading Gas Pressure	36
Wiring for Heat Only Thermostat	14	Electrode Orientation and Gap	37
Wiring for Electronic Heat-Cool Thermostat	14	Wiring Diagram for DFAA - Gas Conversion Burner	38
Wiring for Standard Heat-Cool Thermostat	14	Wiring Diagram for DFAH - Gas Gun	39

LIST OF TABLES

Unit Clearances to Combustibles	4	Timings and Settings	22
Minimum Duct Sizing For Proper Airflow	6	Burner Specifications	23
Round Duct Size	6	Filter Performance - Pressure Drop Inches W.C. and (kPa)	25
External Static Pressure Range	9	Blower Performance CFM	25
Filter Sizes	10	Replacement Parts - Non Electrical	26
Burner Specifications	11	Gas Line Piping Size and Length	30
Burner Rating at Elevation Above Sea Level, gph (l/m)	12	Length of Standard Pipe Threads in Inches (mm)	30
Ratings & Physical / Electrical Data	13	High Altitude Duration Chart	32
Roof Jack Options	17	Gas Burner Settings	32
Cad Cell Resistance When Sensing Flame	22	Inlet Gas Pressure Range	35
		Nominal Manifold Pressure	35

SECTION I: SAFETY



This is a safety alert symbol. When you see this symbol on labels or in manuals, be alert to the potential for personal injury.

Understand and pay particular attention to the signal words **DANGER**, **WARNING**, or **CAUTION**.

DANGER indicates an **imminently** hazardous situation, which, if not avoided, **will result in death or serious injury**.

WARNING indicates a **potentially** hazardous situation, which, if not avoided, **could result in death or serious injury**.

CAUTION indicates a **potentially** hazardous situation, which, if not avoided **may result in minor or moderate injury**. It is also used to alert against unsafe practices and hazards involving only property damage.

WARNING

Improper installation may create a condition where the operation of the product could cause personal injury or property damage. Improper installation, adjustment, alteration, service or maintenance can cause injury or property damage. Refer to this manual for assistance or for additional information, consult a qualified contractor, installer or service agency.

CAUTION

This product must be installed in strict compliance with the installation instructions and any applicable local, state, and national codes including, but not limited to building, electrical, and mechanical codes.

SPECIFIC SAFETY RULES AND PRECAUTIONS

1. **U.S.**.....No. 1 or No. 2 heating oil only (ASTM D396), **CANADA**.....No. 1 stove oil or No. 2 furnace oil only are approved for use and can be burned in this furnace. Refer to the furnace rating plate or SECTION IV of these instructions.
2. Install this furnace only in a location and position as specified in SECTION I of these instructions.
3. An oil-fired furnace for installation in a residential garage must be installed as specified in SECTION I of these instructions.
4. Combustion products must be discharged outdoors. The Roof Jack vent system is the only approved vent system that can be installed on this furnace. Install as specified in SECTION VI of these instructions.

WARNING

FIRE OR EXPLOSION HAZARD

Failure to follow the safety warnings exactly could result in serious injury, death or property damage.

Read all instructions before proceeding. Follow all instructions completely. Failure to follow these instructions could result in equipment malfunction, causing severe personal injury, death, or substantial property damage.

5. Test for leaks in the oil line as specified in SECTION VIII of these instructions.
6. Always install the furnace to operate within the furnace's intended temperature rise range. Only connect the furnace to a duct system which has an external static pressure within the allowable range, as specified on the furnace rating plate.
7. The return air duct system is not required by the furnace manufacturer. This furnace utilizes a sealed combustion air and vent system referred to as a roof jack. The Roof Jack must be installed as specified in these instructions and must conform with state, local, or regional codes.
8. It is permitted to use the furnace for heating of buildings or structures under construction. Installation must comply with all manufacturer's installation instructions including:
 - Proper vent installation;
 - Furnace operating under thermostatic control;
 - Return air filter door must be sealed to the furnace;
 - Air filters in place;
 - Set furnace input rate and temperature rise per rating plate marking;
 - Means for providing outdoor air required for combustion;
 - Return air temperature maintained between 55°F (13°C) and 80°F (27°C);
 - The air filter must be replaced or thoroughly cleaned upon substantial completion of the construction process;
 - Clean furnace, duct work and components upon substantial completion of the construction process, and verify furnace operating conditions including ignition, input rate, temperature rise and venting, according to the manufacturer's instructions.

The following requirements to be met:

- a. Clean, outside combustion air is provided to the furnace to minimize the impact of corrosive adhesives, sealants, and other construction materials. Drywall dust is a major concern during construction, which can be pulled into the combustion air path, leading to plugged heat exchangers, burners, and inducer assemblies.
- b. Filter must be installed in the furnace as specified in the installation instructions, and must be replaced or thoroughly cleaned prior to occupancy of the home. Again, drywall dust is the key issue, as that dust can be pulled into the circulating blower motor, plugging the motor vents, coating the rotors and stators, etc. which can lead to a potential fire hazard.

- c. The temperature of the return air to the furnace must not be less than 55° F (13° C), with no evening setback or furnace shutdown, to prevent condensation in the primary heat exchangers.
 - d. The air temperature rise must be within the stated rise range as indicated on the furnace rating plate, and the firing input rate must be set to the unit nameplate value.
 - e. The external static pressure of the air distribution system ductwork must be set for heating operation to be at least 0.12 (.03 kPA) to 0.30 (0.7 kPA) inches water column, based on the input rate of the furnace, with the lower value for input rates at 66,000 btu/hr and the upper value for units with input rates at 84,000 btu/hr.
 - f. The furnace and ductwork should be thoroughly and completely cleaned prior to occupancy of the dwelling to insure the proper operation of the furnace and to avoid potential health concerns.
9. In Canada refer to the Oil-fired Central Furnace Installation code, CAN B40.9.3. When installed in a Manufactured (Mobile) Home, combustion air shall not be supplied from occupied spaces.
 10. The size of the unit should be based on an acceptable heat loss calculation for the structure. ACCA, Manual J or other approved methods may be used.
 11. **Manufactured (Mobile) Home and Modular Home Installation:** This appliance must be installed in a (sealed combustion) configuration using a roof jack vent system. A roof jack is the only approved vent system that can be used to vent this appliance.
 12. **Modular Home Definition:** Factory-built home constructed to the state, local, or regional code where the house will be located. The home is transported in one or more modules and joined at the home site.
 13. **Manufactured (Mobile) Home Definition:** Factory-built home constructed, transported and installed under the federal building code administered by the U.S. Department of Housing and Urban Development (HUD Code), rather than to building codes at their destination. The house is built, transported and installed on a non-removable chassis.
 14. This furnace is approved for installation in trailers or recreational vehicles.

SAFETY REQUIREMENTS

CAUTION

- *Never attempt to alter or modify this furnace or any of its components.*
 - *Never attempt to repair damaged or inoperable components. Such action could cause unsafe operation, explosion, fire and/or asphyxiation.*
 - *If a malfunction has occurred, or if you feel that the furnace is not operating as it should, contact a qualified service agency or oil supplier for assistance.*
- A manufactured (mobile) home installation must conform with the Manufactured Home Construction and Safety Standard, Title 24 CFR, Part 3280, Federal Manufactured Home Construction & Safety Standard (H.U.D., Title 24, Part 3280) or when such standard is not applicable, the standard for Manufactured Home Installations (Manufactured Home Sites, Communities, and Set-ups) NFPA 31 Installation of Oil-Burning Equipment, CAN/CSA B139 Installation Codes). This furnace has been certified to the latest edition of standard UL 727 Standard for Safety for Oil-Burning Equipment, and for Oil-Fired Central Furnaces (Latest Edition), CSA B140.10 (Latest Edition), and all local codes and ordinances.
 - Refer to the unit rating plate for the furnace model number, and then see the dimensions page of these instructions for return air door dimensions in Figure 2. The filter(s) must be installed according to the instructions.

- Provide clearances from combustible materials as listed under Furnace Locations and Clearances.
- Provide clearances for servicing, ensuring that service access is allowed for both the burners and blower.
- These models are ETL listed and approved for installation into a Modular Home or a Manufactured (Mobile) Home.
- **Failure to carefully read and follow all instructions in this manual can result in furnace malfunction, death, personal injury and/or property damage.**
- Furnaces for installation on combustible flooring shall not be installed directly on carpeting, tile or other combustible material other than wood flooring.
- Check the rating plate and power supply to be sure that the electrical characteristics match. All models use nominal 115 VAC, 1 Phase, 60-Hertz power supply. **DO NOT CONNECT THIS APPLIANCE TO A 50 HZ POWER SUPPLY OR A VOLTAGE ABOVE 130 VOLTS.**
- Furnace shall be installed so the electrical components are protected from water.
- Installing and servicing heating equipment can be hazardous due to the electrical components and the oil fired components. Only trained and qualified personnel should install, repair, or service oil heating equipment. Untrained service personnel can perform basic maintenance functions such as cleaning and replacing the air filters. When working on heating equipment, observe precautions in the manuals and on the labels attached to the unit and other safety precautions that may apply.

NOTICE SPECIAL REQUIREMENTS

▲ DANGER

This equipment must be installed, adjusted, and started only by a qualified service agency - an individual or agency, licensed and experienced with all codes and ordinances, who is responsible for the installation and adjustment of the equipment. The installation must comply with all local codes and ordinances and with the latest revision of the National Fire Protection Association Standard NFPA31 (or CSA B139).

These instructions cover minimum requirements and conform to existing national standards and safety codes. In some instances these instructions exceed certain local codes and ordinances, especially those who have not kept up with changing Modular Home and Manufactured (Mobile) Home construction practices. These instructions are required as a minimum for a safe installation.

COMBUSTION AIR QUALITY (LIST OF CONTAMINANTS)

The furnace will require **OUTDOOR AIR** for combustion when the furnace is located in any of the following environments.

- Restricted Environments
- Commercial buildings
- Buildings with indoor pools
- Laundry rooms
- Hobby or craft rooms
- Near chemical storage areas
- Chemical exposure

The furnace will require **OUTDOOR AIR** for combustion when the furnace is located in an area where the furnace is being exposed to the following substances and / or chemicals.

- Permanent wave solutions
- Chlorinated waxes and cleaners
- Chlorine based swimming pool chemicals
- Water softening chemicals
- De-icing salts or chemicals
- Carbon tetrachloride
- Halogen type refrigerants
- Cleaning solvents (such as perchloroethylene)
- Printing inks, paint removers, varnishes, etc.
- Hydrochloric acid
- Cements and glues
- Antistatic fabric softeners for clothes dryers
- Masonry acid washing materials

When outdoor air is used for combustion, the combustion air intake duct system termination must be located external to the building and in an area where there will be no exposure to the substances listed above.

▲ WARNING

The furnace area must not be used as a broom closet or for any other storage purposes, as a fire hazard may be created. Never store items, such as the following, on, near or in contact with the furnace.

1. *Spray or aerosol cans, rags, brooms, dust mops, vacuum cleaners or other cleaning tools.*
2. *Soap powders, bleaches, waxes or other cleaning compounds; plastic items or*
3. *Containers, gasoline, kerosene, cigarette lighter fluid, dry cleaning fluids or other volatile fluid.*
4. *Paint thinners and other painting compounds.*
5. *Paper bags, boxes or other paper products*

Never operate the furnace with the blower door removed. To do so could result in serious personal injury and/or equipment damage.

INSPECTION

As soon as the furnace and/or accessories are received, it should be inspected for damage during transit. If damage is evident, the extent of the damage should be noted on the carrier's freight bill. A separate request for inspection by the carrier's agent should be made in writing. Also, before installation, the furnace and/or accessories should be checked for screws or bolts which have loosened in transit, or shipping and spacer brackets that need to be removed.

▲ NOTICE

CONCEALED DAMAGE - *If you discover damage to the burner or controls during unpacking, notify carrier at once and file the appropriate claim.*

▲ NOTICE

WHEN CONTACTING BECKETT FOR SERVICE INFORMATION - *Please record the burner serial number (and have available when calling or writing). You will find the serial number on the Underwriters Laboratories label, located on the left rear of the burner, or cover mounting plate. See Figure 1.*

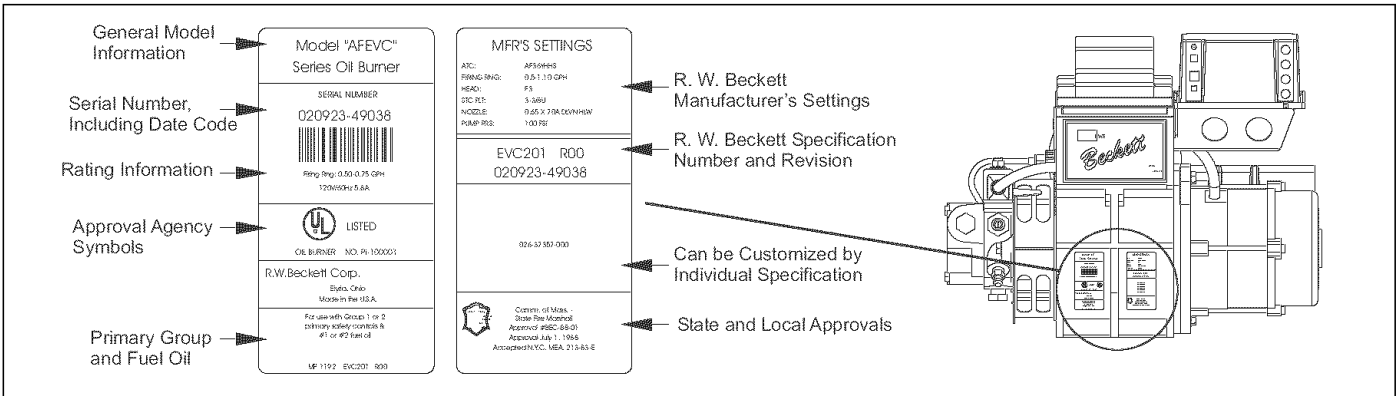

FIGURE 1: Label Location

CHECK CERTIFICATIONS / APPROVALS

- Underwriters Laboratories has certified this burner to comply with ANSI/UL 296 and has listed it for use with #1 or #2 fuel oil as specified in ASTM D396. Low sulfur #1 and #2 fuel oils reduce heat exchanger deposits with all burners compared to the standard fuels. Reduced deposits may extend the service interval for cleaning and improve the efficiency of the appliance over time. Low sulfur fuels reduce particulate and oxides of nitrogen emissions as well. The Oil heat Manufacturers' Association recommends these fuels as the preferred fuels for this burner.
- State and local approvals are shown on burner rating label (See Figure 1).
- All oil burners must be installed in accordance with the regulations of the latest revision of the National Fire Protection Association Standard NFPA 31 and in complete accordance with all local codes and authorities having jurisdiction. Regulation of these authorities take precedence over the general instructions provided in this installation manual.

FURNACE LOCATION AND CLEARANCES

The furnace shall be located using the following guidelines:

- The furnace should be located where the roof jack can be installed without major modifications to the roof of the structure.
- As centralized with the air distribution as possible.
- Where there is access to fresh air particularly when the blend air accessory will be installed.
- Where it will not interfere with proper air circulation in the confined space.
- Where the outdoor section of the roof jack will not be blocked or restricted. Refer to "VENT CLEARANCES" located in SECTION VI of these instructions. These minimum clearances must be maintained throughout the installation.
- Where the unit will be installed in a level position with no more than 1/4" (0.64 cm) slope side-to-side and front-to-back to provide a proper roof jack connection and seal.

Installation in freezing temperatures:

- Furnace shall be installed in an area where ventilation facilities provide for safe limits of ambient temperature under normal operating conditions. Ambient temperatures below 32° F (0° C) may result in the vent temperature falling below 260° F (127° C) at any point in the vent pipe. Vent temperatures below 260° F (127° C) will cause the flue products in the vent pipe to condense causing the vent pipe to deteriorate rapidly.

TABLE 1: Unit Clearances to Combustibles

APPLICATION	TOP	FRONT	BACK	SIDES	AIR INLET PIPING	ROOF JACK	DUCT ¹	FLOOR/BOTTOM
	In. (cm)	In. (cm)	In. (cm)	In. (cm)	In. (cm)	In. (cm)	In. (cm)	
CLOSET	2 (5.08)	6 (15.24)	0 (0.0)	0 (0.0)	0 (0.0)	3 (7.62)	0 (0.0)	0 (0.0)
ALCOVE	2 (5.08)	24 (60.96)	0 (0.0)	0 (0.0)	0 (0.0)	3 (7.62)	0 (0.0)	0 (0.0)

1. Approved Duct Connector must be used. Refer to Section II - Ductwork.

- Do not allow return air temperature to be below 55° F (13° C) for extended periods. To do so may cause condensation to occur in the main heat exchanger, leading to premature heat exchanger failure.

WARNING
Installation in an ambient below 32°F (0.0° C) could create a hazard, resulting in damage, injury or death.

- If this furnace is installed in an unconditioned space and an extended power failure occurs, there will be potential damage to the internal components. Following a power failure situation, do not operate the unit until inspection and repairs are performed.

Clearances for access:

Ample clearances should be provided to permit easy access to the unit. The following minimum clearances are recommended:

- Twenty-four (24) inches (61 cm) between the front of the furnace and an adjacent wall or another appliance, when access is required for servicing and cleaning.
- Twenty-four (24) inches (61 cm) at the side where access is required for passage to the front when servicing or for inspection or replacement of flue/vent connections.

In all cases, accessibility clearances shall take precedence over clearances for combustible materials where accessibility clearances are greater.

WARNING
*Check the rating plate and power supply to be sure that the electrical characteristics match. All models use nominal 115 VAC, 1 Phase 60Hz power supply.
 Furnace shall be installed so the electrical components are protected from water.*

Installation in a residential garage:

- An oil-fired furnace for installation in a residential garage must be installed so the burner(s) and the ignition source are located not less than 18 inches (46 cm) above the floor, and the furnace must be located or protected to avoid physical damage by vehicles.

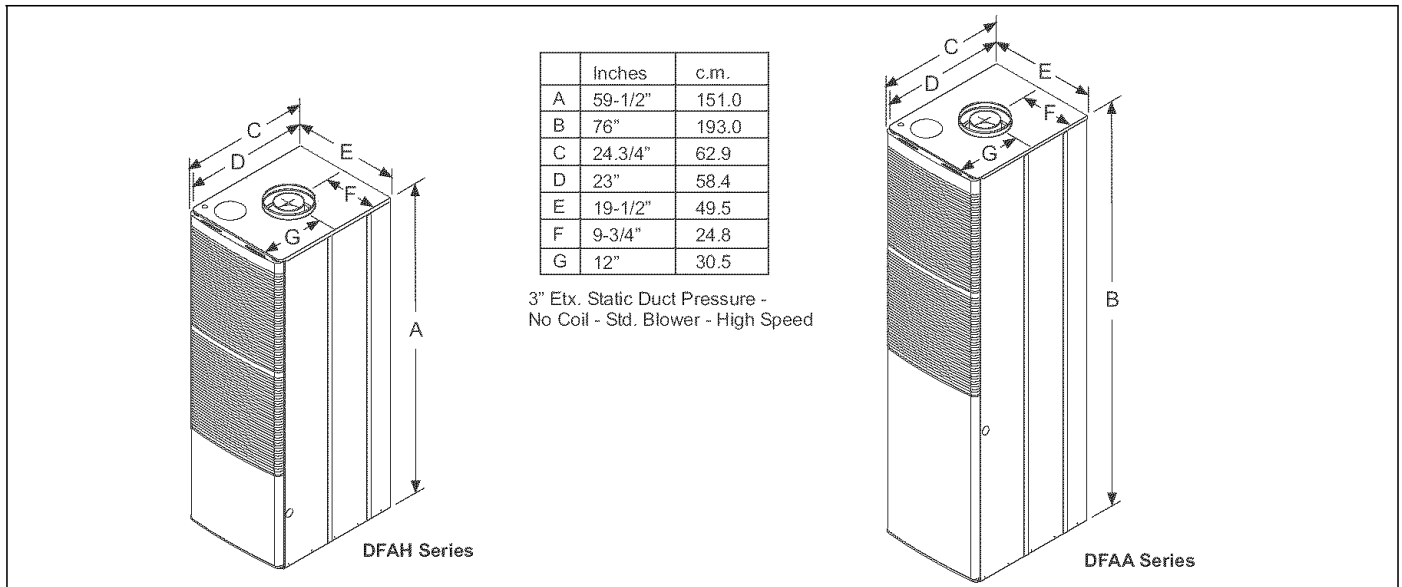

FIGURE 2: Dimensions

SECTION II: DUCTWORK

DUCTWORK GENERAL INFORMATION

The duct system's design and installation must:

1. Handle an air volume appropriate for the served space and within the operating parameters of the furnace specifications.
2. Be installed in accordance with standards of NFPA (National Fire Protection Association) as outlined in NFPA pamphlets 90A and 90B (latest editions), in Canada CAN/CGA-B149.1-00, Installation Code for Oil-Burning Equipment, or applicable national, provincial, or state, and local fire and safety codes.
3. **For Manufactured (Mobile) Home and Modular Home Return Duct System Installations:**
A return air duct and the return air plenum cannot be installed on this furnace. The return air is drawn through the louvers on the blower door. The vent system is a Sealed Combustion Direct Roof Jack Vent System. This is the **ONLY** vent system approved for use on this furnace.
4. Complete a path for heated or cooled air to circulate through the air conditioning and heating equipment and from the conditioned space.
5. Consideration should be given to the heating capacity required and also to the air quantity (CFM) required. These factors can be determined by calculating the heat loss and heat gain of the home or structure. If these calculations are not performed and the furnace is over-sized, the following may result:
 - a. Short cycling of the furnace.
 - b. Wide temperature fluctuations from the thermostat setting.
 - c. Reduced overall operating efficiency of the furnace.

CAUTION

On DFAA furnaces, the cooling coil must be installed in the bottom of the casing. DFAH furnaces must have the cooling coil installed downstream of the furnace. Cooled air may not be passed over the heat exchanger.

When the furnace is used in conjunction with a cooling coil, the coil must be installed parallel with, or in the supply air side of the furnace to avoid condensation in the primary heat exchanger. When a parallel flow arrangement is used, dampers or other means used to control airflow must be adequate to prevent chilled air from entering the furnace. If manually operated, the damper must be equipped with means to prevent the furnace or the air conditioner from operating unless the damper is in full heat or cool position.

WARNING

The duct system must be properly sized to obtain the correct airflow for the furnace size that is being installed.

Refer to Table 8 and the furnace rating plate for the correct rise range and Table 4 for static pressures.

If the ducts are undersized, the result will be high duct static pressures and/or high temperature rises which can result in a heat exchanger **OVERHEATING CONDITION**. This condition can result in premature heat exchanger failure, which can result in personal injury, property damage, or death.

WARNING

HAZARD OF ASPHYXIATION, DO NOT COVER OR RESTRICT FLOOR OPENING.

The duct system is a very important part of the installation. **If the duct system is improperly sized, the furnace will not operate properly.** The ducts attached to the furnace duct connector should be of sufficient size so that the furnace operates at the specified external static pressure and within the air temperature rise specified on the nameplate.

IMPORTANT: Fabricate and install an inspection door in the plenum base below the unit to allow an annual inspection of the heat exchangers. The inspection door can be fabricated by following method.

1. Cut a rectangular opening in the plenum base.
2. A Sheet metal plate can be made that completely covers the opening in the base.
3. The plate must be secured with screws.
4. This plate must be sealed to prevent leaks.

Table 2 is a guide for determining whether the rectangular duct system that the furnace is being connected to, is of sufficient size for proper furnace operation.

Use the example below to help you in calculating the duct area to determine whether the ducts have sufficient area so that the furnace operates at the specified external static pressure and within the air temperature rise specified on the nameplate.

Example: The furnace input is 80,000 BTUH, (23.4 kW) 1,200 CFM (34.0 m³). The recommended duct area is 280 inch² (1, there are two 8 in x 14 in (20.3 cm x 35.6 cm) rectangular ducts attached to the plenum and there are two 7 inch (722 cm²) round ducts attached to the furnace.

1. Take 8 in x 14 in (20.3 cm x 35.6 cm), which equals 112 inch² X 2 (35.6 cm x 2), which equals 224 inch² (1445 cm²) then go to round duct size located in Table 3.

TABLE 2: Minimum Duct Sizing For Proper Airflow

Input	Airflow	Return ¹	Rectangular ²	Round ²	Supply ³	Rectangular ²	Round ²
BTU/H (kW)	CFM(m ³)	In ² (cm ²)	in. x in. (cm x cm)	in. (cm) dia	In ² (cm ²)	in. x in. (cm x cm)	in. (cm) dia.
66000 (19.34)	1,050 (29.73)	280 (711)	14 x 20 (35.6 x 50.8)	18(45.7)	216(549)	12 x 18 (30.5 x 45.7)	16 (40.6)
84000 (24.62)	1,250 (35.40)	360 (914)	18 x 20 (45.7 x 50.8)	22(55.8)	280(711)	14 x 20 (35.6 x 50.8)	18 (45.7)

NOTE: This chart does not replace proper duct sizing calculations or take into account static pressure drop for run length and fittings. Watch out for the temperature rise and static pressures.

1. Maximum return air velocity in rigid duct @ 700 feet per minute (19.82 m³ / minute).
2. Example return main trunk duct minimum dimensions.
3. Maximum supply air velocity in rigid duct @ 900 feet per minute (25.49 m³ / minute).

TABLE 3: Round Duct Size

Round Duct Size	Calculated Area For Each Round Duct Size
Inches (cm)	Sq. Inch (cm ²)
5 (13)	19.8 (126)
6 (15)	28.2 (182)
7 (18)	38.4 (248)
8 (20)	50.2 (324)
9 (23)	63.6 (410)
10 (25)	78.5 (506)
11 (28)	95.0 (613)
12 (30)	113.1 (730)
13 (33)	132.7 (856)
14 (36)	153.9 (993)

1. The Air Temperature Rise is determined by subtracting the Return Air Temperature Reading from the Supply Air Temperature Reading.
2. The External Static Pressure is determined by the Supply Duct Static Pressure reading.

TABLES 2 and 3 are to be used as a guide only to help the installer determine if the duct sizes are large enough to obtain the proper air flow (CFM) through the furnace. TABLES 2 and 3 ARE NOT to be used to design ductwork for the building where the furnace is being installed. There are several variables associated with proper duct sizing that are not included in the tables. To properly design the ductwork for the building, Refer to the ASHRAE Fundamentals Handbook, Chapter on "DUCT DESIGN" or a company that specializes in Residential and Modular Home duct designs.

WARNING

The supply air temperature **MUST NEVER** exceed the **Maximum Supply Air Temperature**, specified on the nameplate.

Operating the furnace above the maximum supply air temperature will cause the heat exchanger to overheat, causing premature heat exchanger failure. Improper duct sizing, dirty air filters, incorrect oil pump pressure, incorrect oil orifice and/or a faulty limit switch can cause the furnace to operate above the maximum supply air temperature. Refer to SECTIONS II, III and VIII for additional information on correcting the problem.

2. The square inch area for 7 inch (17.8 cm) round pipe is 38.4, multiply by 2 for two round ducts which equals 76.8 inch² (495 cm²).
3. Then take the 224 inch² (1445 cm²) from the rectangular duct and add it to the 76.8 inch² (495 cm²) of round duct. The total square inch of duct attached to the furnace plenum is 300.8 inch² (1,940 cm²). This exceeds the recommended 280 inch² (1,806 cm²) of duct.

In this example, the duct system attached to the plenum has a sufficient area so that the furnace operates at the specified external static pressure and within the air temperature rise specified on the nameplate.

DUCKWORK INSTALLATION

Air Distribution Systems

For proper air distribution, the supply duct system shall be designed so that the static pressure does not exceed the listed static pressure rating on the furnace rating plate.

Three typical distribution systems are illustrated in Figure 3.

Location, size and number of registers should be selected on the basis of best air distribution and floor plan of the home.

The Air Temperature Rise is to be adjusted to obtain a temperature rise within the range(s) specified on the furnace rating plate.

DUCT DESIGN - CANADA

Supply duct design shall be in accordance with the latest HRA Digest, the ASHRAE Handbook Fundamentals, or other good engineering principles.

NOTE: Refer to HRA Digest Residential Air System Design Manual, Sections 5 and 6, the requirements of which are summarized as follows:

1. The kilowatt output of each duct register shall not exceed 2.35 kW.
2. The furnace output should not be more than 20% greater than the calculated heat loss of the home. If a larger furnace is used, the duct system shall be capable of the increased air volumes necessary to maintain a maximum air temperature rise of 50° C as the air passes over the furnace heat exchanger.
3. At least one warm air supply outlet shall be provided in each room.
4. When rooms are located adjacent to the exterior walls, warm air outlets shall be located so as to bathe at least one exterior wall and, where practical, a window area with warm air, except for bathrooms or kitchens where this might not be practical.
5. Where practical, outlets shall be provided near the exterior doors of the home.

CLEARANCE REQUIREMENTS - CANADA

Supply air ducts from warm air furnaces having a specified minimum plenum clearance shall maintain this clearance from combustible material for at least the distance specified in CSA Standards C22.2 No. 23 or B140.10 or CGA Standard CAN/CGA-2.3.

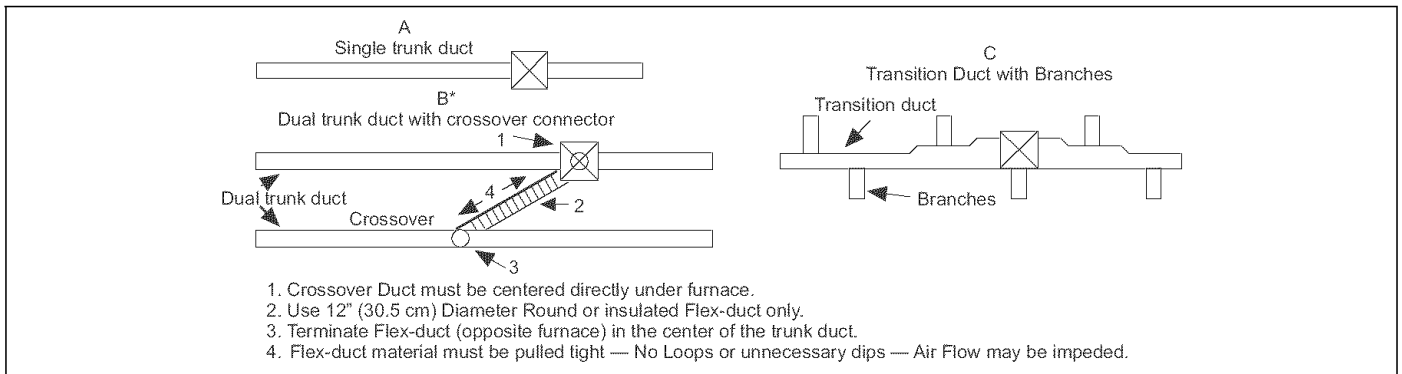

FIGURE 3: Air Distribution Systems

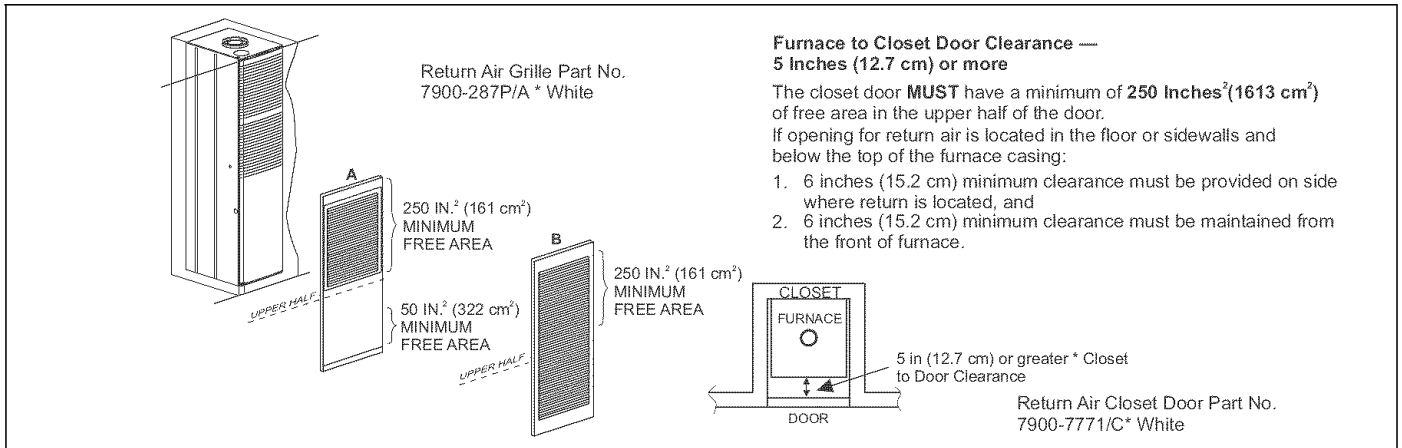

FIGURE 4: Closet To Door Clearance - 5" or Greater

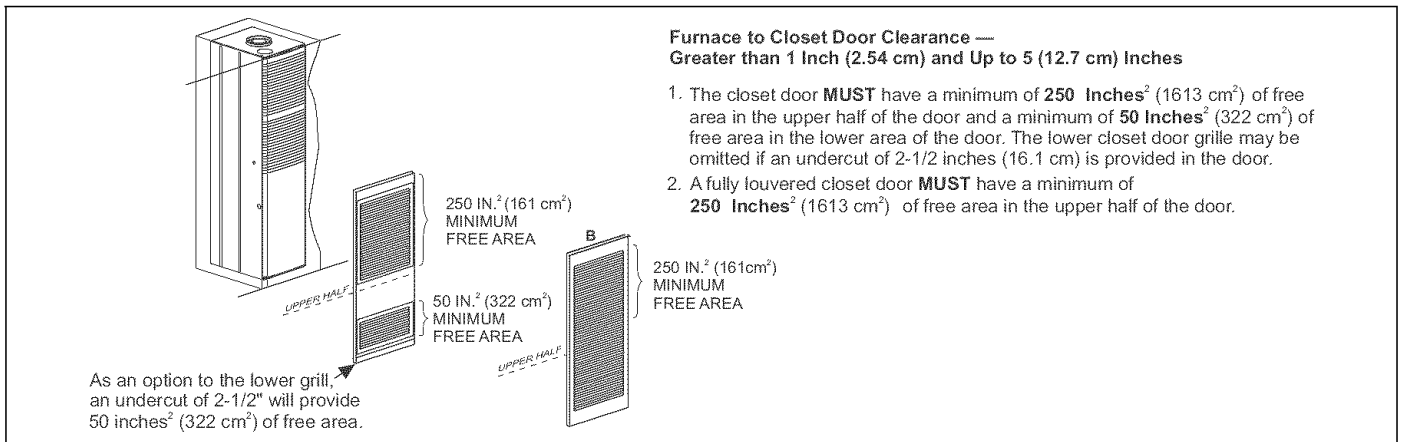

FIGURE 5: Furnace To Closet Door Clearance - 1" To 5"

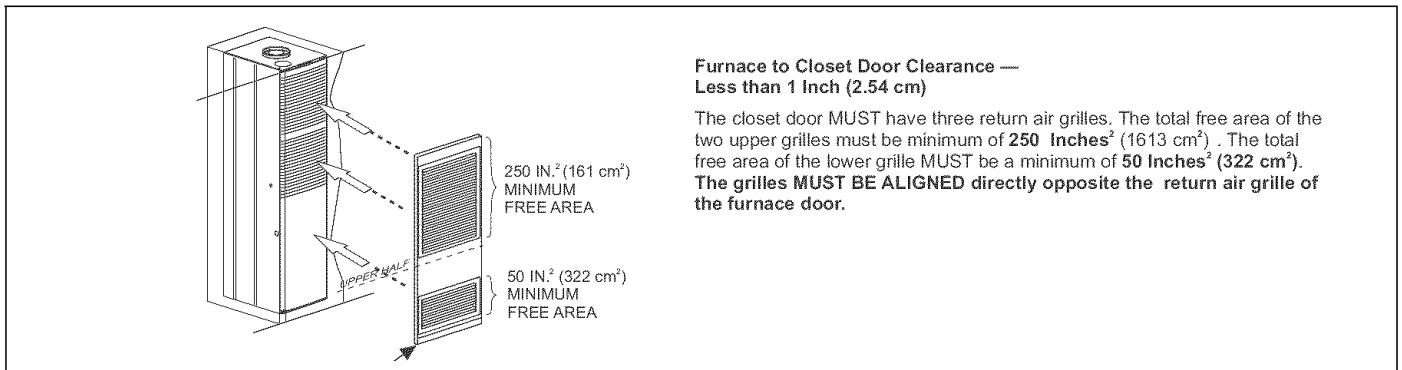

FIGURE 6: Furnace To Closet Door Clearance - Less Than 1"

DUCT CONNECTORS

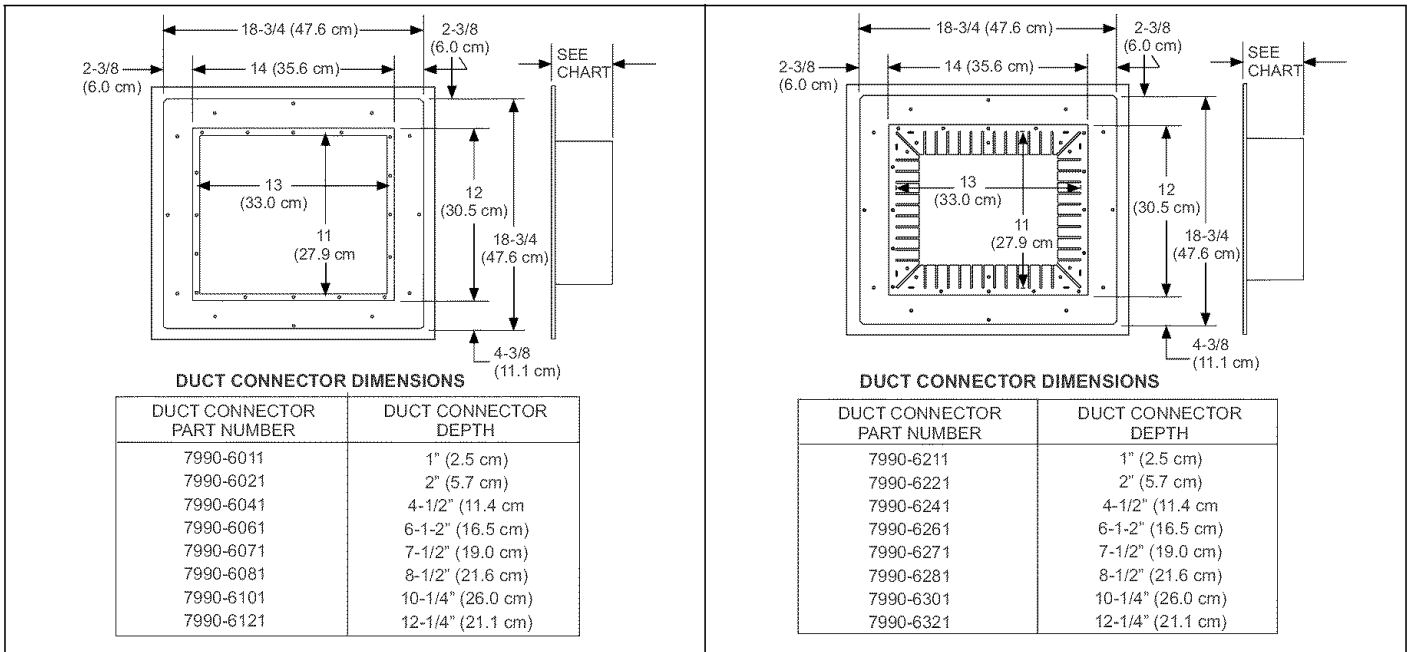

FIGURE 7: Duct Connector Dimensions

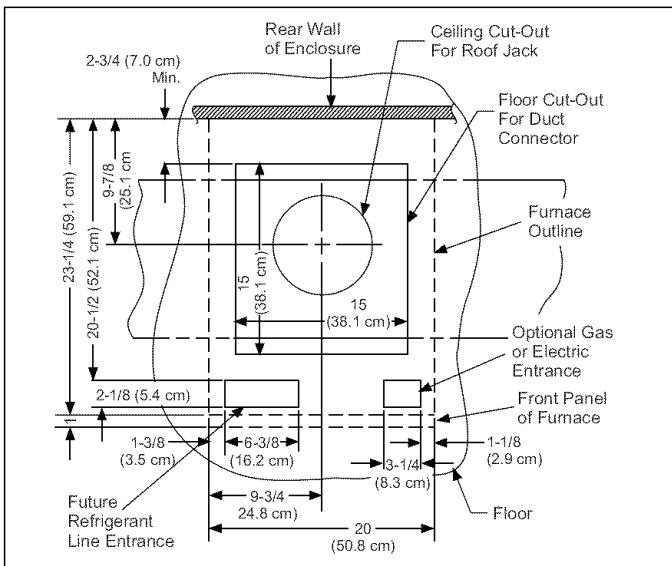

FIGURE 8: Recommended Floor Cut-out

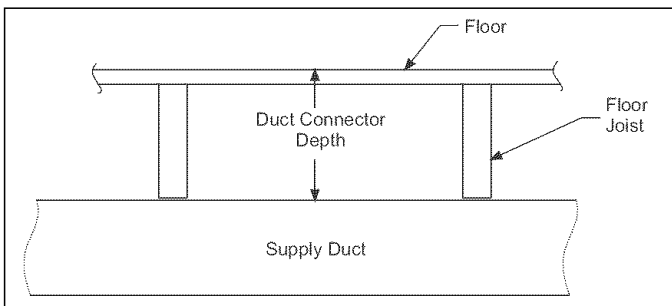

FIGURE 9: Duct Connector Depth

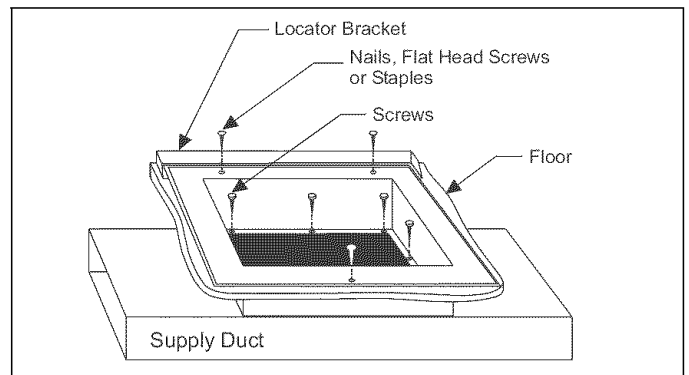

FIGURE 10: Duct Connector Screw Attachment

INSTALLATION OF SCREW ATTACHMENT DUCT CONNECTOR

1. Make floor cut out as shown in Figure 8.
2. Determine the depth of the floor cavity from the surface of the floor to the top of the supply air duct and select the appropriate duct connector from the chart.
3. Place locating bracket (supplied with the duct connector) to the back edge of the floor opening. See Figure 10.
4. Apply a water based duct sealant to the 1/2 in (1.3 cm) supply duct attachment flange of the duct connector.
5. Determine which of the four positions the duct connector best centers over the supply duct and insert it through the floor cut-out.
6. When properly aligned with the supply duct, secure the duct connector to the floor with nails, flat head screws or staples.
7. Use screws as required to secure the duct connector to the supply duct.
8. Cut out the opening to the supply duct. If sealant was not used, the installer should tape the mating flanges to provide a good air seal.

NOTE: Duct sealant and tape must be classified as meeting HUD Standard 3280.715, U.L. Standard 181A.

If tape is used to provide a better air seal, it should be a type approved by the applicable national or local codes.

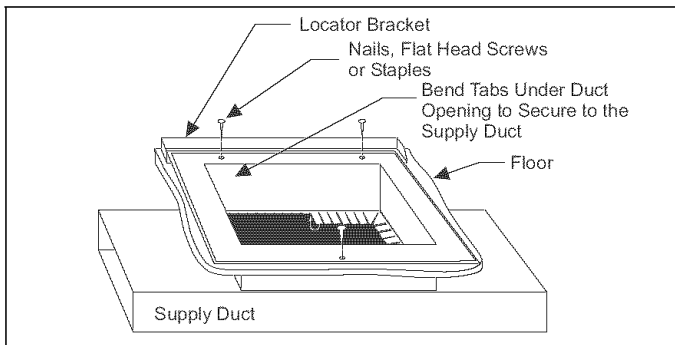

FIGURE 11: Duct Connector Tab Attachment

INSTALLATION OF TAB ATTACHMENT DUCT CONNECTORS

1. Make floor cut out as shown in Figure 8.
2. Determine the depth of the floor cavity from the surface of the floor to the top of the supply air duct and select the appropriate duct connector from the chart.
3. Place locating bracket (supplied with the duct connector) to the rear of the floor area for the furnace. See Figure 11.
4. Determine which of the four positions the duct connector best centers over the supply duct and insert it through the floor cut-out.
5. Mark cut-out location on the supply duct and remove the duct connector.
6. Cut out the opening to the supply duct.
7. Bend tabs down through and back up under the supply duct.
8. Secure the duct connector to the floor with nails, flat head screws or staples.

The duct connector is designed for use on ducts down to 12 in (30.5 cm) width. When using the connector on smaller width ducts, there will not be sufficient clearance to bend the tabs on two sides of the duct connector.

In such cases the tabs may be attached to the sides of the duct by using sheet metal screws or other suitable fasteners. Holes for sheet metal screws are provided in three (3) tabs on each side of the duct connector. If more than 3 tabs need to be used to provide a more secure and air tight connection, the remaining tabs can also be fastened to the duct with screws after drilling the required screw hole.

TABLE 4: External Static Pressure Range

Input		Output		Nominal Air Flow ¹		Ext. Static Pressure			
MBH	kW	MBH	kW	CFM	cmm	Minimum		Maximum	
						In.W.C	kPa	In.W.C	kPa
66000	19.34	53000	15.55	1050	29.73	.12	.03	.30	.07
84000	24.62	67000	19.63	1250	35.40	.12	.03	.30	.07

1. Std. Blower-High Speed-No Coil.

IMPORTANT: The air temperature rise should be taken only after the furnace has been operating for at least 15 minutes. Temperatures should be taken 6" (15.2 cm) past the first bend from the furnace in the supply duct. The return air temperature must be taken at the return air louvered door. Return static pressures can be taken by pushing probe through the air filter on the louvered door.

Furnace and Air Conditioner Installations

If an air conditioner is installed which does not use the blower for air distribution and operates completely independent of the furnace, the thermostat system must have an interlock to prevent the furnace and air conditioner from operating at the same time. This interlock system usually contains a heat-cool switch which must be turned to either HEAT or COOL to activate either heating or cooling operation, or a positive OFF switch on the cooling thermostat.

When used in connection with a cooling unit the furnace shall be installed parallel with or on the upstream side of the cooling unit to avoid condensation in the heat exchanger.

For installations with a parallel flow arrangement, the furnace must be equipped with a damper to prevent cold air from being discharged up around the heat exchanger. Cold air causes condensation inside the exchanger and can cause it to rust out which can allow products of combustion to be circulated into the living area by the furnace blower resulting in possible asphyxiation. An air flow activated automatic damper, is available from furnace manufacturer. See Figure 12.

NOTE: See label on coil panel for conversion and lighting instructions. Obtain a temperature rise within the ranges specified on the name plate.

CAUTION

All installations must have a filter installed.

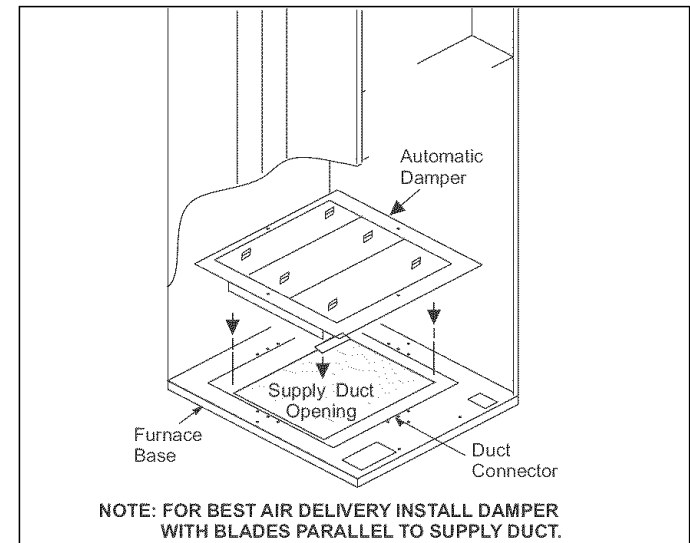

NOTE: FOR BEST AIR DELIVERY INSTALL DAMPER WITH BLADES PARALLEL TO SUPPLY DUCT.

FIGURE 12: Anti-Backflow Damper

INSTALLATION OF THE FURNACE

1. Remove the front panels and set the furnace onto the duct connector. Slide it back until the rear of the unit engages the locator bracket.
2. Secure the front of the furnace with two screws at the mounting holes provided. See Figure 13.

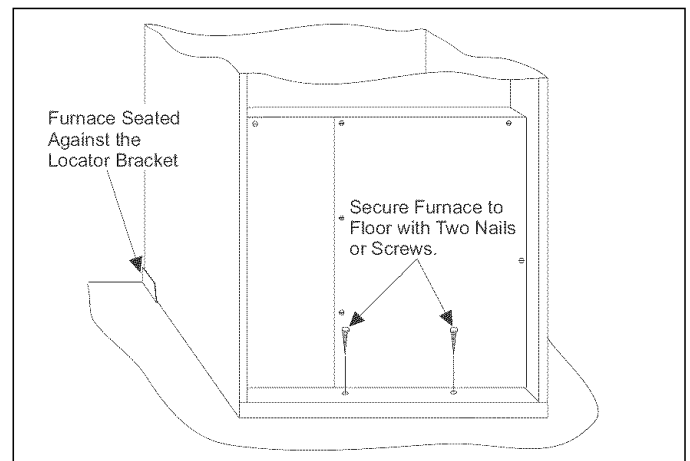

FIGURE 13: Installation of Furnace

3. Secure the top of the furnace to a structural member using screw through the strap at the back of the furnace. Strap may be moved to any of the holes located along the top back of the furnace. Installer may provide an equivalent method, such as screws through the casing side.

DFAH Furnaces:

If a matching cooling coil is used, it may be placed directly on the furnace outlet and sealed to prevent leakage. Follow the coil instructions for installing the supply plenum. On all installations without a coil, a removable access panel is recommended in the outlet duct such that smoke or reflected light would be observable inside the casing to indicate the presence of leaks in the heat exchanger. This access cover shall be attached in such a manner as to prevent leaks.

RETURN AIR REQUIREMENTS

Closet Installations

Additional Requirements

Additional requirements for floor and ceiling return system for closet installed sealed combustion heating appliances are given in the next paragraph.

Floor or Ceiling Return Air System

Listed in the next paragraph are the conditions to be met by Manufactured Home Manufacturers to have U.L. acceptance of in-floor or ceiling return air systems of closet installed direct vent forced air heating appliances for Manufactured Homes to be sold in the United States.

1. The return air opening into the closet, regardless of location, is to be sized not less than 16" X 24" (40.6 cm x 101.6 cm).
2. If the return air opening is located on the floor of the closet (versus the vertical front or side wall), the opening is to be provided with means to prevent its inadvertent closure by a flat object placed over the opening.
3. The cross sectional area of the return duct system (when located in the floor or ceiling of the manufactured home) leading into the closet is to be not less than 16" X 24" (40.6 cm x 101.6 cm).
4. At least one register is to be located where likelihood of its being covered by carpeting, boxes, and other objects is minimized.
5. Materials located in the return duct system have a flame spread classification of 200 or less.
6. Non-combustible pans having 1" (2.5 cm) upturned flanges are located beneath openings in the floor return duct system.
7. Wiring materials located in the return duct system conform to Article 300-22 (B&C) of the National Electrical Code (NFPA-70).
8. Fuel piping is not run in or through the return duct system.
9. The negative pressure in the closet as determined by test with the air circulating fan operating at high heating speed and the closet door closed is to be not more negative than minus 0.05 inches (1.2 kPa) water column.
10. For floor return systems, the manufactured home manufacturer or installer shall affix a prominent marking on or near the appliance where it is easily read when the closet door is open. The marking shall read:

▲ WARNING

HAZARD OF ASPHYXIATION, DO NOT COVER OR RESTRICT FLOOR OPENING

BLEND AIR INSTALLATIONS

If a blend air ventilation system is installed, the 5" (12.7 cm) diameter knockout in the top cover must be removed. The blend air damper is to be placed on the top cover and secured with screws as shown in Figure 14. The power wires for the Blend Air Damper are inserted through the 7/8" (2.22 cm) hole in the top cover. The wires to the Blend Air Damper will be connected as shown in Figure 24. Refer to the Blend Air Installation Manual to complete the installation.

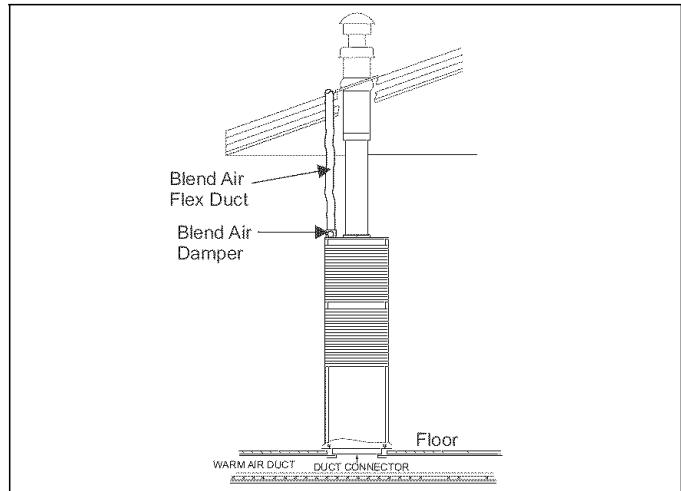

FIGURE 14: Floor Installation

SECTION III: FILTERS

FILTER INSTALLATION

All applications require the use of a filter. A standard air filter is located in the return filter rack on the louvered door. The air filter(s) must be replaced with air filter(s) that are the same size and same type. Replacement filter size is shown in Table 5.

Downflow Filters:

There are two types of downflow filter racks.

1. **FURNACE FILTER RACK:** A return filter rack is with two standard throwaway type filters are supplied on all models. The return filter rack is located on the inside of the louvered door. This type of filter rack is designed for two standard air filters only. Pleated Media or Washable Filters cannot be used in this filter rack because they cause too much pressure drop causing a reduction in airflow.
2. **EXTERNAL RETURN FILTER GRILLE:** The second type is an external return air filter grille that **can only be used in applications where the furnace is installed in a closet**. This type of filter grille is typically installed in a closet door or wall with the filters located within 12" (30.5 cm) of the return air opening of the furnace. There must be a minimum clearance of 6" (15.2 cm) between the front of the furnace and the closet door and/or the furnace and the filter grille to prevent the return air flow from being obstructed. Refer to Table 1 Unit Clearances to Combustibles.
 - a. If the standard throwaway filter are used the external filter grille must have a minimum area of 540 in² (3483 cm²) which would equal a 15" X 36" (38.1 cm x 91.4 cm) filter grille.
 - b. If the Pleated Media or Washable Filters are used the external filter grille must have a minimum area of 684 in² (4413 cm²) which would equal a 18" X 38" (38.1 cm x 91.4 cm) filter grille. The increased area is to reduce the pressure drop across the air filter.
 - c. Consideration should be given when locating the return filter grille for maintenance.
 - d. Any filter that has a large pressure drop should be checked to be sure the pressure drop caused by the air filter will not prevent the furnace from operating within the rise range, specified on the rating plate and in Table 8. If the furnace does not operate within the specified rise range then a larger air filter or an air filter that has a lower pressure drop must be installed.

TABLE 5: Filter Sizes

Input / Output BTU/H (kW)	CFM (m ³ /mm)	Top Return Filter In. (cm)
66 / 53 (19.34 / 15.53)	1050 (29.73)	(2) 14 x 20 (35.56 x 50.8)
84 / 67 (24.62 / 19.64)	1250 (35.40)	(2) 14 x 20 (35.56 x 50.8)

IMPORTANT: Air velocity through throwaway type filters must not exceed 300 feet per minute (1.52 m/m).

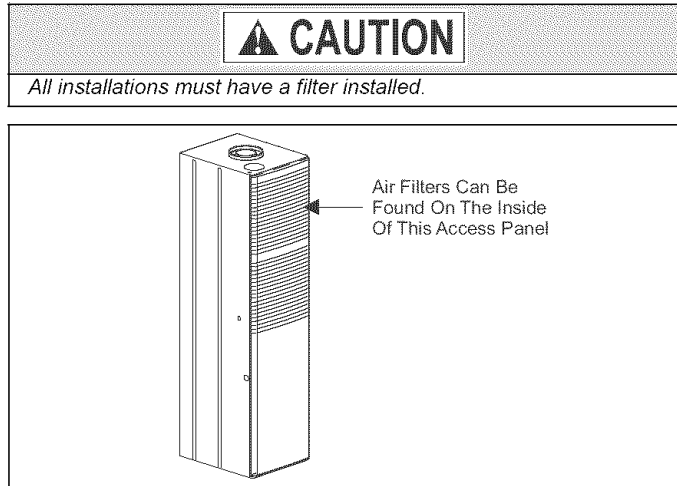

FIGURE 15: Furnace Air Filters

SECTION IV: OIL PIPING

OIL SAFETY

IMPORTANT INFORMATION: Long or oversized inlet lines may require the pump to operate dry during initial bleeding period. In such cases, the priming may be assisted by injecting fuel oil in the pump gearset. Under lift conditions, lines and fittings must be air tight. To assure this, "Pipe Dope" may be applied to both the used and unused inlet and both return fittings. **DO NOT USE TEFLON TAPE! DO NOT USE COMPRESSION FITTINGS!**

VACUUM CHECK: A vacuum gauge may be installed in either of the 1/4" NPT inlet ports. The Beckett CleanCut pump should be used where the vacuum does not exceed 6" hg. (20.3 kPa) single pipe and 12" hg. (40.6 kPa) two pipe. Remember, running vacuum is the total of all pressure drops (ΔP) in the system from tank to inlet of pump.

PRESSURE CHECK: When a pressure check is made, use either the BLEED PORT OR NOZZLE PORT.

CUTOFF CHECK: To check cut-off pressure, dead head a pressure gauge in nozzle port. Run burner for short period of time. Shut burner off. The pressure will drop and hold above zero

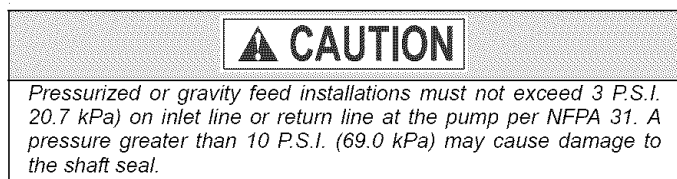

CONNECT FUEL LINES

Carefully follow the fuel unit manufacturer's literature and the latest edition of NFPA 31 for oil supply system specifications. If this information is unavailable, use the following basic guidelines.



TABLE 6: Burner Specifications

Furnace Model	Burner Spec	ATC	Head
DFAA084BBTA DFAH084BBSA	EVC - 201	AF36YHHS	F3
DFAA066BBTA DFAH066BBSA	EVC - 202	AF36YHHS	F3
Static Plate	Nozzle	Pump Pressure	Air Boot Setting
3-3/8 U	0.65 x 70° A Delavan	100 psi (689.5 kPa)	4.0
3-3/8 U	0.50 x 70° A Delavan	100 psi (689.5 kPa)	3.0

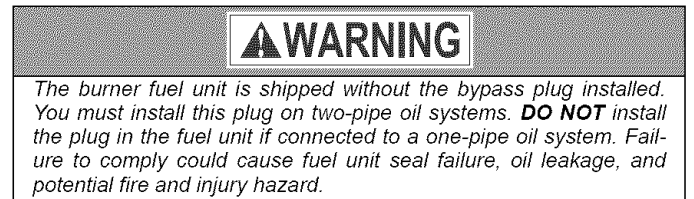

Fuel Supply Level With or Above Burner

The burner may be equipped with a single-stage fuel unit for these installations. Connect the fuel supply to the burner with a single supply line if you want a one-pipe system (making sure the bypass plug is NOT installed in the fuel unit). Manual venting of the fuel unit is required on initial start-up. If connecting a two-pipe fuel supply, install the fuel unit bypass plug.

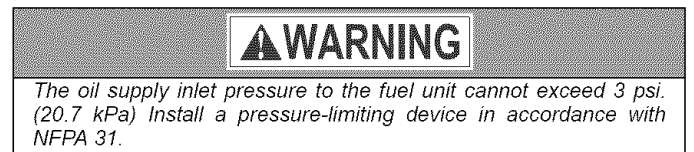

Fuel Supply Below the Level of the Burner

When the fuel supply is below the level of the burner, a two-pipe fuel supply system is required. Depending on the fuel line diameter and horizontal and vertical length, the installation may also require a two-stage pump. Consult the fuel unit manufacturer's literature for lift and vacuum capability.

Fuel Line Installation

- Continuous lengths of heavy wall copper tubing are recommended. **Always use flare fittings. Never use compression fittings.**
- Always install fittings in accessible locations. Fuel lines should not run against the appliance or the ceiling joists (to avoid vibration noise).

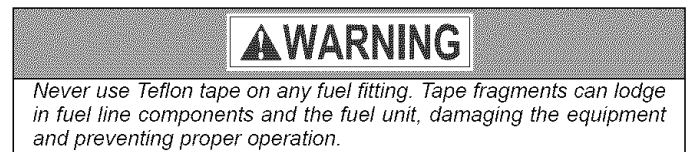

Fuel Line Valve and Filter

Install two high quality shut-off valves in accessible locations on the oil supply line. Locate one close to the tank and the other close to the burner, upstream of the filter.

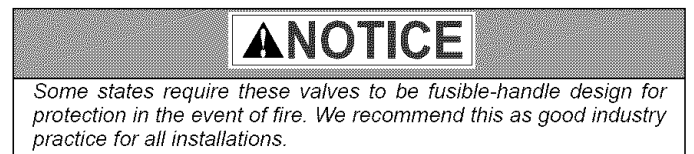

Install a generous capacity filter inside the building between the fuel tank shut-off valve and the burner, locating both the filter and the valve close to the burner for ease of servicing. The filter should be rated for 50 microns (50 micrometers) or less.

NOTICE SPECIAL REQUIREMENTS

CAUTION

This equipment must be installed, adjusted, and started only by a qualified service technician, an individual or agency, licensed and experienced with all codes and ordinances, who is responsible for the installation and adjustment of the equipment. The installation must comply with all local codes and ordinances and with the National Fire Protection Standard for Liquid Fuel Equipment, NFPA 31 (or in Canada the installation must comply with CSA B139-M91).

CAUTION

This pump must be used with a control system that provides a valve on delay (pre-purge).

DANGER

This furnace is designed to operate on #1 FUEL-OIL or #2 FUEL-OIL ONLY. Do Not burn any other fuel in this furnace. Burning any fuel except #1 FUEL-OIL or #2 FUEL-OIL in this furnace can cause premature heat exchanger burnout, high levels of carbon monoxide, excessive sooting, a fire hazard, personal injury, property damage, and/or death.

In Canada, the furnace is designed to operate on #1 STOVE OIL or #2 FURNACE OIL ONLY.

THE EFFECT OF ELEVATION ON OIL BURNER FIRING

The elevation of the installation of a modern high-speed flame retention oil burner affects the performance of the burner. Allowance for elevation must be taken into consideration when choosing an oil burner and operating it above 2000 ft. (610m).

It is especially important in high elevation installations to adjust air settings to match the burner nozzle firing rate. As elevation increases above sea level, the ambient air contains less oxygen. Because there is less available oxygen per cubic foot of air, the burner must deliver a greater volume flow (cfm) of air to provide the proper amount of oxygen for the amount of oil being burned. This is the reason that an increase in the burner air setting may be required.

It is also important in high elevation installations to consider the maximum firing rate of the burner, so that the heat input as required by the application is maintained. Regardless of elevation, the oil burner has a maximum volume flow of air that it can deliver. As a result, the maximum firing rate of the oil burner decreases as the elevation increases, because the combustion air contains less oxygen. An increase in the size of a fixed-type retention head, or even the use of an oil burner with a higher maximum firing rate may be necessary.

The effect of elevation up to 2000 ft. (610 m) is minimal, so no re-rate is necessary up to 2000 ft. (610 m) elevation. Above 2000 ft. (610 m), for every 1000 ft. (305 m) above sea level (including the first 2000 ft. (610 m)), there is a 1.84% rate reduction of the burner. To assist you, we have included the following chart and some examples: Refer to Table 7.

DANGER

The pressure regulator on the fuel pump must not be adjusted in excess of 100 PSIG (689 kPa).

Pressures exceeding 100 PSIG (689 kPa) may cause an overheating condition which can lead to premature heat exchanger failure, resulting in a fire or explosion, or cause damage to the furnace of some of its components that will result in property damage and loss of life. Refer to Figure 16 for Pressure Regulator Location.

TABLE 7: Burner Rating at Elevation Above Sea Level, gph (l/m)

Elevation (Above Sea Level)		Nozzle Size			
		0.50	1.892706	0.65	2.460518
ft	m	gph	l/h	gph	l/h
500	152	0.50	1.89	0.65	2.46
1,000	305	0.50	1.89	0.65	2.46
1,500	457	0.50	1.89	0.65	2.46
2,000	610	0.50	1.89	0.65	2.46
2,500	762	0.49	1.86	0.65	2.46
3,000	914	0.48	1.82	0.64	2.42
3,500	1,067	0.48	1.82	0.64	2.42
4,000	1,219	0.47	1.79	0.63	2.37
4,500	1,372	0.47	1.79	0.63	2.37
5,000	1,527	0.46	1.76	0.61	2.33
5,500	1,676	0.46	1.76	0.61	2.33
6,000	1,829	0.46	1.72	0.60	2.28
6,500	1,981	0.46	1.72	0.60	2.28
7,000	2,134	0.45	1.69	0.59	2.24
7,500	2,286	0.45	1.69	0.59	2.24
8,000	2,438	0.44	1.66	0.58	2.20
9,000	2,743	0.43	1.63	0.57	2.16
10,000	3,048	0.42	1.60	0.56	2.12

Note: All examples are for 7000 ft. elevation.
 1.84% x 7 (for 7000 ft.) = 12.9% → 100% - 12.9% = 87.1%

- ft = feet
- m = meters
- gph = gallons per hour
- l/h = liters per hour

EXAMPLE 1:

Re-Rating of the Maximum Firing Rate for Burners @ 7000 ft.

Burner Model	Maximum Firing Rate of Burner @ Sea Level	X	Elevation Re-rate Factor @ 7000 ft.	=	Adjusted Maximum Firing Rate
AFG	3.00 gph (11.4 L/h)	X	87.1%	=	2.61 gph (9.83 L/h)
AF	3.00 gph (11.4 L/h)	X	87.1%	=	2.61 gph (9.83 L/h)

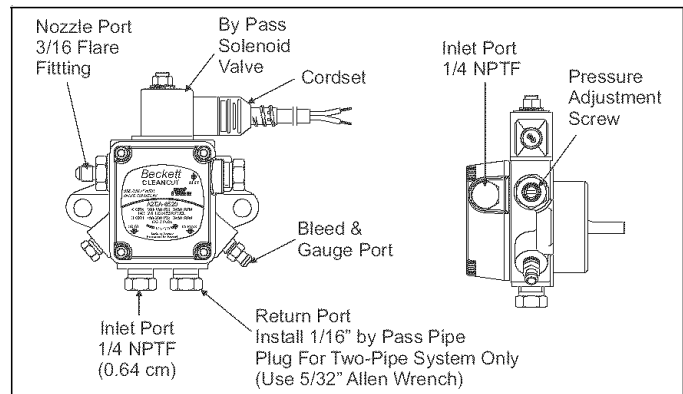

FIGURE 16: Oil Pump

INSTALLATION AND CHECKING OF OIL PIPING

Location and installation of oil tanks and oil piping must comply with local codes and regulations. In absence of such codes, follow NFPA 31: Standard Floor Installation of Oil Burner Equipment.

Follow information provided with the burner, the fuel pump, or the calculation below to determine pipe size and length.

L = Line Length in feet

H = Head in feet

Q = Firing rate in GPH

3/8" (0.95 cm) line $L = (6 - 0.75 \times H) / 0.0086 \times Q$

1/2" (1.27 cm) line $L = (6 - 0.75 \times H) / (0.00218 \times Q)$

If tank is above the oil pump, then use the following calculation:

3/8" (0.95 cm) line $L = (6 + 0.75 \times H) / (0.0086 \times Q)$

1/2" (1.27 cm) line $L = (6 + 0.75 \times H) / (0.00218 \times Q)$

IMPORTANT: The recommended piping configuration is a single or two pipe system that is inserted into the top of the tank as shown in Figure 17 or 18. The two pipe system should be used in applications where the oil tank is considerably lower than the burner and the oil pump keeps losing its prime. The oil line should never be connected to the bottom of the oil tank if the oil tank is outdoors. Water in the bottom of the oil will freeze in the winter causing the oil line to freeze.

ONE PIPE SYSTEM

DO NOT INSTALL BY-PASS PLUG! Connect inlet line to pump inlet. Start burner. Arrange primary burner control for continuous operation during the purging. Place a clear plastic tube on bleed valve. Open bleed valve 1 turn counterclockwise. Bleed until all air bubbles disappear. Tighten bleed valve securely. Hurried bleeding will impair efficient operation of unit. Refer to Figures 16 & 17.

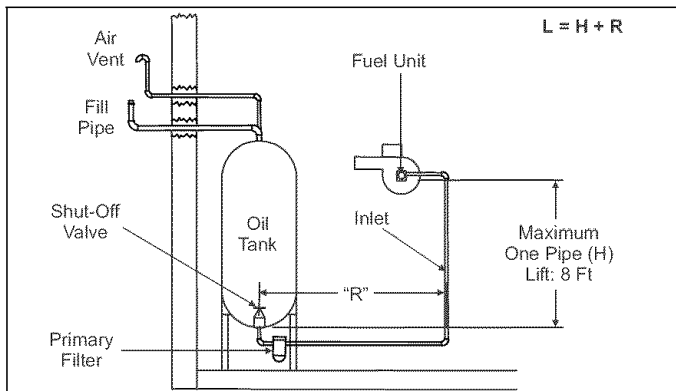

FIGURE 17: One-Pipe System

TWO PIPE SYSTEM

Remove 1/16" (0.16 cm) pipe by-pass plug from plastic bag attached to the unit. Remove 1/4" (0.635 cm) plug from return port. Insert by-pass plug into the return port of the oil pump. The oil pump return port location is shown in Figure 16.

Insert a 1/4" MPT x flare adaptor into the by-pass port and the inlet port. Attach the return and inlet copper lines that go to the oil tank. Start the burner. **DO NOT** open the bleed valve. The air in the oil lines will bleed automatically.

TABLE 8: Ratings & Physical / Electrical Data

Input	Output	Nominal	Burner				Air Temp. Rise	AFUE	Input Rate
			Amps	HP	RPM	Rotation			
66 (19.3)	53 (15.5)	1050 (29.7)	2.1	1/7	3450	CCW	45 - 75 (28 - 47)	80	0.50 (1.9)
84 (24.6)	67 (19.6)	1250 (35.4)	2.1	1/7	3450	CCW	45 - 75 (28 - 47)	80	0.65 (2.5)
Input	Max. Outlet Air Temp	Blower		Max Over-current Size (awg) @ 75 ft. protect	Total Unit	Min. Wire One Way	Blower Size	DFAA Operation Wgt.	DFAH Operation Wgt.
MBH (kW)	°F (°C)	Hp	Amps		Amps				
66 (19.3)	165 (74)	1/6	8.0	15	8.3	14	10 x 8 (25.4 x 20.3)	175/79.4	158/71.7
84 (24.6)	165 (74)	1/4	5.9	15	7.8	14	10 x 8 (25.4 x 20.3)	175/79.4	158/71.7

Annual Fuel Utilization Efficiency (AFUE) numbers are determined in accordance with DOE Test procedures. Wire size and over current protection must comply with the National Electrical Code (NFPA-70-latest edition) and all local codes. The furnace shall be installed so that the electrical components are protected from water. Rotation when facing shaft end.

The return line must terminate 3" to 4" above supply line in the oil tank. Failure to do this may introduce air into the system and could result in the loss of the prime. Refer to Figure 18.

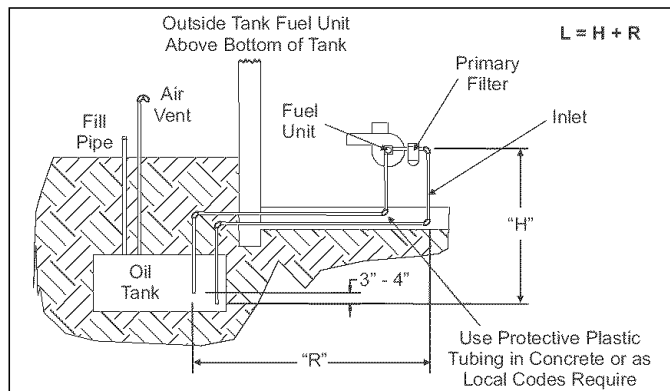

FIGURE 18: Two-Pipe System

SOLENOID WIRING

DISCONNECT THE POWER SUPPLY BEFORE WIRING TO PREVENT ELECTRICAL SHOCK OR EQUIPMENT DAMAGE.

Lead wires on these devices are long enough to reach the junction box on most burner installations. Refer to Figure 19.

NOTE: Check the burner manufacturer's installation sheets for the correct solenoid wiring. All electrical wiring must be done in accordance with the local codes.

NOTE: Solenoid power requirements: 115 VAC, 0.1 Amp, 60 Hz

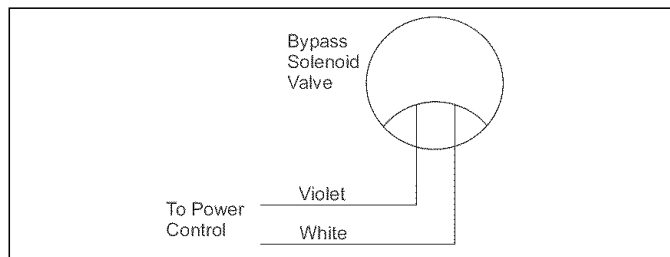

FIGURE 19: Solenoid Wiring

SECTION V: ELECTRICAL POWER

Electrical Power Connections

Field wiring to the unit must be grounded. Electric wires that are field installed shall conform to the temperature limitation for 63°F (35°C) rise wire when installed in accordance with instructions. Refer to Table 8 in these instructions for specific furnace electrical data.

CAUTION

Use copper conductors only.

NOTE: A burner with an electronic igniter or a PSC motor will have a lower operating current. The actual load should be determined by a current meter.

NOTE: See appliance manufacturer's burner specifications for required outlet pressure. Pressure is 100 psig (689 kPa) unless otherwise noted.

SUPPLY VOLTAGE CONNECTIONS

1. Provide a power supply separate from all other circuits. Install overcurrent protection and disconnect switch per local/national electrical codes. With the control box switch in the OFF position, check all wiring against the unit wiring label. Refer to the wiring diagram in this instruction.
2. Remove the screws retaining the wiring box cover. Route the power wiring through the opening in the unit into the junction box with a conduit connector or other proper connection. In the junction box there will be two wires, a Black Wire, a White Wire and a Green Screw. Connect the power supply as shown on the unit-wiring label on the coil compartment panel on the DFAA or the inside of the burner door on the DFAH or the wiring schematic in this section. The black furnace lead must be connected to the L1 (hot) wire from the power supply. The white furnace lead must be connected to neutral. Connect the green furnace lead (equipment ground) to the power supply ground screw.
3. The furnace's control system requires correct polarity of the power supply and a proper ground connection. Refer to Figure 20.

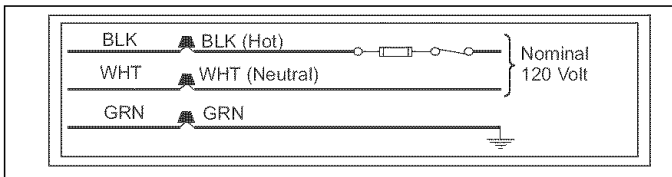

FIGURE 20: Line Wiring Connections

LOW VOLTAGE CONTROL WIRING CONNECTIONS

1. Insert 24 volt wires through the small plastic bushing just above the control panel.
2. Connect the thermostat wires to the furnace low voltage pigtails. See Figure 21 (heating only) and Figure 22 or 23 (heating and cooling).
3. Connect low-voltage circuit to the wall thermostat pigtails.

NOTE: Five-conductor thermostat cable is recommended for all installations to allow easy installation of an air conditioning system at a later time.

Eighteen gauge thermostat wire is highly recommended.

Smaller gauge thermostat wire may be used only if the guideline below is followed.

Thermostat Wire Length (Furnace to Thermostat)	Thermostat Wire Gauge
0 - 45 feet	22
0 - 70 feet	20

Do not use the thermostat wire smaller than 22 gauge. If thermostat wire small than 18 gauge is used, pay particular attention that the connections between the difference wire sizes are tight.

Operational problems may be caused by loose connections or by the use of thermostat wire that is too small to carry the required load. Any such problems are the responsibility of the installer.

A separate 115 V.A.C. supply circuit must be used for the furnace. The circuit should be protected by a 15 amp fuse or circuit breaker.

Avoid locations where the thermostat could be subject to drafts from outside, or exposed to direct light from lamps, sun, fireplaces, etc., or affected by air from a duct register blowing directly on the thermostat.

The wall thermostat should be located 52 to 66 inches above the floor. The preferred location is on an inside wall situated in an area with good air circulation, and where the temperature will be reasonably representative of other living areas the thermostat is controlling.

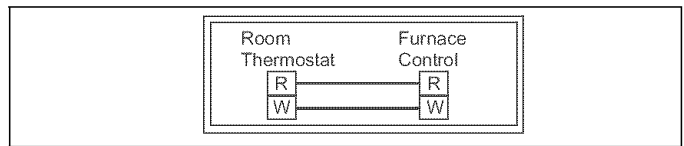

FIGURE 21: Wiring for Heat Only Thermostat

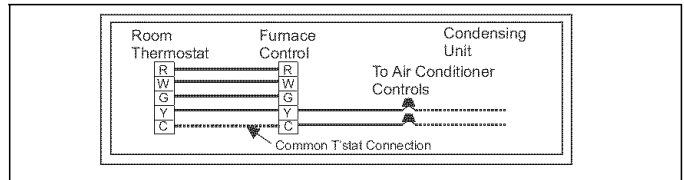

FIGURE 22: Wiring for Electronic Heat-Cool Thermostat

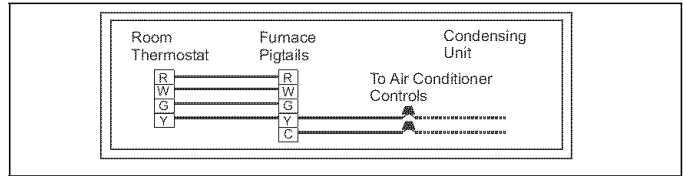

FIGURE 23: Wiring for Standard Heat-Cool Thermostat

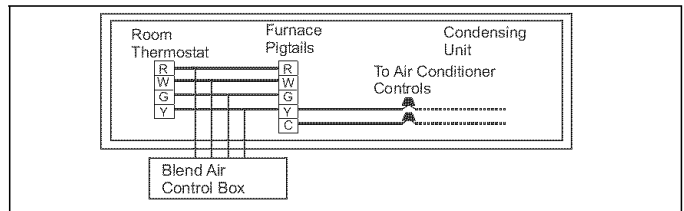

FIGURE 24: Wiring for Blend Air Accessory

IMPORTANT: Some electronic thermostats do not have adjustable heat anticipators. They may have other type cycle rate adjustments. Follow the thermostat manufacturer's instructions.

The 24-volt transformer is part of the Electronic Oil Primary Control. The transformer may not be used to provide 24-Volt power for an air conditioning unit contactor. DFAA has a separate 24-Volt transformer that maybe used to provide 24-volt power for air conditioning contactor.

SECTION VI: VENT/COMBUSTION AIR SYSTEM

VENT AND COMBUSTION AIR SAFETY

This furnace is designed for Manufactured (Mobile) Home and Modular Home application. It may be installed without modification in an equipment room, alcove, or any other indoor location where all required clearance to combustibles and other restrictions are met.

The venting system must be installed in accordance with UL311 Standard For Safety for Roof Jacks for Manufactured (Mobile) Homes and Recreational Vehicles, NFAA 501C and in the Federal Manufactured Home Construction and Safety Standings, or CAN/CSA - B139-00 Installation Code for Oil Burning Equipment (latest edition), or applicable provisions of the local building code and these instructions. The furnace shall not be connected to any chimney, a flue serving a separate appliance, or any appliance designed to burn solid fuel.

It is recommended that the appliance is installed in a location where the space temperature is 32 °F (0°C) or higher. If the appliance is installed in a location where the ambient temperature is below 32 °F (0°C), the combustion by-products could condense causing damage to the appliance heat exchanger and/or the Roof Jack.

IMPORTANT: The "VENT SYSTEM" must be installed as specified in these instructions for Manufactured (Mobile) Home and Modular Homes. This appliance must be vented with an approved manufacturer supplied roof jack. May not be common vented with another gas-fired or oil-fired appliance.

EXTERIOR ROOF JACK EXTENSION

Application

Available to comply with instances in which the roof jack crown needs to be raised to meet a roof clearance requirement. One extension will raise the roof jack crown by 18" 45.7 cm).

ROOF JACK

⚠ WARNING

Failure to follow all venting instructions can result in fire, asphyxiation, or explosion.

⚠ CAUTION

Only use the appropriate roof jack. See Figures 26, 27, 30, & 31 for correct application.
Do not exceed the maximum height as determined from Table 9. Installer should allow an additional 1-1/2" (3.8 cm) travel before the flue pipe assembly is fully extended against the built-in stop. This provides an additional safeguard against the flue assembly being pulled from the roof jack during transportation or other stress conditions.

EXISTING FURNACE REPLACEMENT

If this furnace replaces an existing furnace, do the following:

1. If a 2nd roof, roof cap or addition has been made to the existing roof of the home, remove the old roof jack completely! To avoid the possibility of an improperly installed pipe or gaps in the old roof jack, INSTALL A NEW ROOF JACK. Your ceiling and roof height will determine the correct roof jack to use.
2. After unpacking the roof jack, check the rain caps. Insure they are not damaged, tilted or crooked. Do not twist, crush or sit on the roof caps during installation. Damaged roof caps will cause improper furnace operation. The furnace will not heat properly and could result in explosion.
3. Before inserting the roof jack into the furnace top, inspect the furnace flue and combustion air opening for debris or insulation which might have fallen in during pre-installation steps. Do not proceed unless all debris has been cleaned out or removed.
4. After installing roof jack on furnace top collar, check to make sure there is no gap in back or side between the pipe collar and the furnace casing top.
5. Use only the pipes provided with the roof jack assembly. Do not add to or adapt other sheet metal pipes. Do not cut, insert or add other pipes to this assembly.
6. In no case should there be a gap between sections of the flue pipe or the combustion air pipe. If necessary to prevent excessive air leakage, the installer should seal joints in the combustion air tube with aluminum type or other suitable sealant.

NEW HOME INSTALLATION

If this furnace is installed in a new home do the following:

1. Inspect the furnace top collars for signs of insulation or ceiling debris which might have fallen in during cutting of the ceiling and roof holes. Remove all debris before continuing.

⚠ DANGER

The vent and combustion air openings in the top of the furnace must be free of construction debris before the Roof Jack is installed. Failure to ensure that these openings are free will result in excessive amounts of CARBON MONOXIDE and elevated heat exchanger temperatures which can lead to premature heat exchanger failure, resulting in a fire or explosion or cause damage to the furnace or some of its components that will result in property damage and loss of life.

2. After unpacking the roof jack, check the rain caps. Insure they are not damaged, tilted or crooked. Do not twist, crush or sit on the roof caps during installation. Damaged roof caps will cause improper furnace operation. The furnace will not heat properly and could result in explosion.
3. Before inserting the vent pipe into the furnace top, inspect the furnace flue and combustion air opening for debris or insulation which have fallen in during pre-installation steps. Do not proceed unless all debris have been cleaned out or removed.
4. After installing roof jack on furnace top collar, check to make sure there is no gap in back or side between the pipe collar and the furnace casing top. If necessary to prevent excessive air leakage, the installer should seal joints in the combustion air tube with aluminum type or other suitable sealant.

INSTALLATION IN SNOW REGIONS

When the combustion air pipe inlet is covered or blocked with snow, the furnace will not operate properly due to the depleted combustion air supply.

Therefore, if the furnace will be located in regions where snow accumulation on the roof exceeds 4" or in H.U.D. Snow Load Zones, a roof jack extension and PVC combustion air inlet extension is recommended. Refer to Figure 26 or 27.

COMBUSTION AIR INLET

All combustion air pipe and fittings must conform to American National Standards Institute (ANSI) standards and American Society for Testing and Materials (ASTM) standards D1785 (Schedule 40 PVC), D2665 (PVC-DWV), F891 (PVC-DWV cellular core), D2241 (SDR-21 and SDR-26 PVC), D2261 (ABS-DWV), or F628 (Schedule 40 ABS). Pipe cement and primer must conform to ASTM Standards D2564 (PVC) or D2235 (ABS).

1. Mark vertical combustion air inlet centerline on ceiling. Cut hole for combustion air inlet piping. Clearance to combustible materials is not required.
2. Cut hole in roof. Provide minimum 12" (30.5 cm) vertical separation between combustion air inlet pipe and roof jack vent cap. Clearance to combustible materials is not required.
3. Route piping through ceiling and holes. Provide firestop as required.
4. Insert combustion air inlet coupling into casing. See Figure 26 or 27.
5. Slide PVC pipe into coupling. Use a hose clamp to secure the PVC pipe to the coupling.
6. Complete piping through roof. Provide flashing at roof penetration.
7. Prepare elbow assembly. See Figure 25. Insert screen into elbow socket. Secure in place with street elbow (or nipple).
8. PVC pipe can be straight through the roof or it can be offset by using up to 4-90° elbows. Horizontal PVC pipe can be up to 10 ft. (3.1 m) long in any direction from the furnace vent connection. Vertical PVC pipe can be up to 10 ft. (3.1 m) in length.

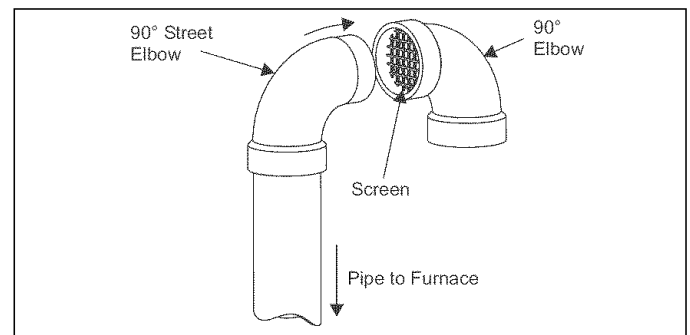

FIGURE 25: Elbow Assembly

9. Attach elbow assembly to combustion air inlet piping. See Figure 26 or 27. Inlet must be minimum 6" (15.2 cm) above highest anticipated snow level, but no more than 24" 61.0 cm) above roof.

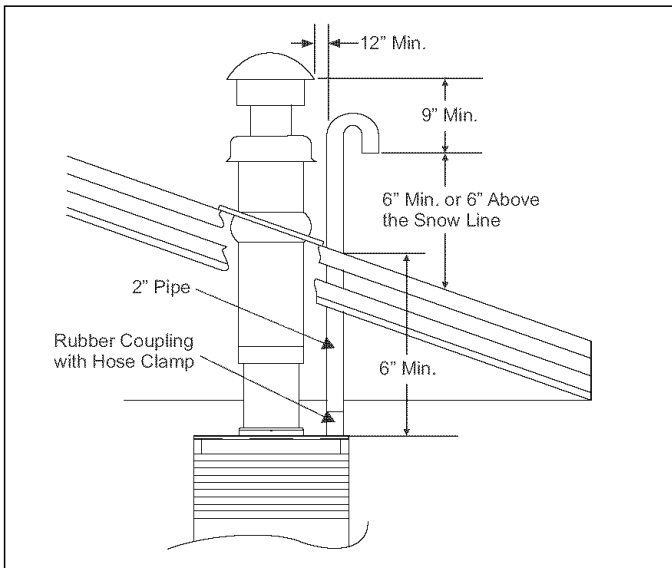

FIGURE 26: Combustion Air Inlet Pipe

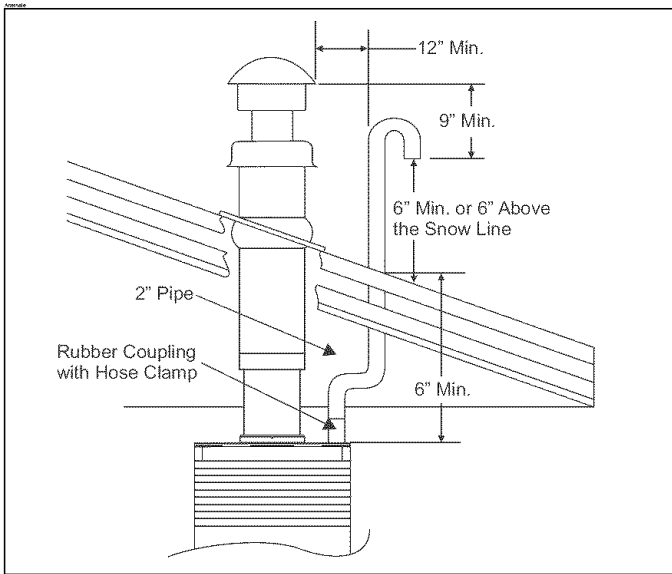

FIGURE 27: Combustion Air Inlet Pipe Alternate

NOTE: Roof flashing, PVC pipe, PVC 90° elbows and fire stop are not supplied with the furnace.

LOCATING AND CUTTING ROOF JACK OPENING

To facilitate the proper installation of the roof jack, it is very important that the roof jack opening in the ceiling and roof be on the same vertical center line as the furnace flue collar. See Figures 30 & 31.

Mark this location on ceiling and scribe a circle with a 5" (1.5 m) radius {10" (25.4 cm) diameter} around this mark. Cut opening for roof jack through ceiling and roof. (If furnace was installed during construction, cover furnace and flue opening to prevent debris from entering flue when hole is cut for roof jack).

INSTALLING ROOF JACK IN ROOF

1. Provide protection for Vent Connector and Air-Intake Connector from damage and debris.
2. Mark Roof Jack center line on ceiling. Cut a 5" (1.5 m) radius {10" (25.4 cm) diameter} hole through ceiling.
3. Mark Roof Jack center line on roof. Cut oblong hole through roof.
4. Insert Roof Jack through roof opening. Do not secure Roof Jack to roof.

Connect Roof Jack to Furnace

1. Install Flue Shield inside Vent Connector. Push Flue Shield down until in contact with the built-in stop inside the Vent Connector. See Figures 28 & 29.

WARNING

Failure to install the Flue Shield may cause premature flue pipe deterioration. Damaged flue pipe can result in asphyxiation, fire or equipment malfunction.

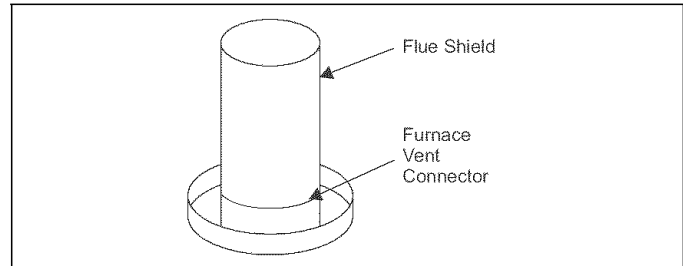

FIGURE 28: Flue Shield Installation

2. Verify gasket is around outside of Air-Intake Connector. Install new gasket if missing or damaged.
3. Pull the Roof Jack's telescoping section down onto furnace. Fully engage Roof Jack onto Vent Connector and Air-Intake Connector and compress gasket. See Figure 29. Refer to Interior Roof Jack Extension installation instructions, if applicable.
4. Align holes in Roof Jack and Air-Intake Connector. Secure Roof Jack to furnace using #10 x 1/2 - 1-1/2" (#10 x 1.3 - 3.8 cm) Type AB or Type B sheet metal screw.

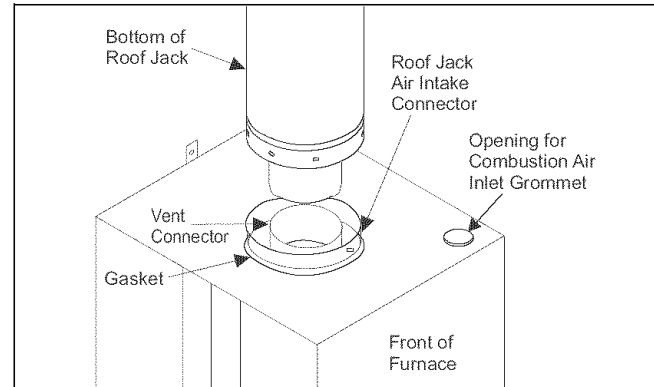

FIGURE 29: Roof Jack Attachment to Furnace

INTERIOR EXTENSIONS

There is an optional 11" (43.2 cm) long interior extension that can be used to provide added interior roof jack length, if needed. To choose the proper length roof jack with or without the optional extension see Figures 30 & 31 and Table 9. More than one interior extension may be used to accommodate "A" dimensions up to 110" (284.5 cm).

WARNING

The joint where the optional interior extension connects to the roof jack must be below the ceiling. Failure to observe this requirement may result in asphyxiation, fire, or explosion

NOTE: Use of an interior extension will increase the roof jack adjustable heights by the amount of the interior extension height.

CAUTION

Do not exceed the maximum adjustable height as listed in Table 9. These maximum heights allow an additional 1 1/2" (3.81 cm) travel before the flue pipe assembly is fully extended against the built-in stop. This provides an additional safeguard against the flue assembly being pulled from the roof jack if upward movement should occur when the home is being transported or subjected to other stress conditions. Failure to follow these instructions may result in fire, explosion, or asphyxiation.

TABLE 9: Roof Jack Options

Roof Jack Part Number	Adjustable Height with no Interior Extension		Adjustable Height with a 17" Interior Extension	
	IN	CM	IN	CM
4000B7141	14" to 78"	35.6 to 198.1	64" to 95"	162.6 to 241.3
4000B7151	66" to 90"	165.1 to 228.6	83" to 107"	210.8 to 271.8
4000B8161	59" to 79"	149.9 to 200.7	76" to 96"	193.0 to 243.8
4000B8181	73" to 103"	185.4 to 261.6	90" to 110"	228.6 to 279.4

Models 4000B8161 and 4000B8181 have removable crowns.

CAUTION

Use 1/2" (1.27 cm) blunt or sharp end sheet metal screws to fasten roof jack combustion air pipe to furnace combustion air collar. Screw holes are provided in pipe and collar. Excessively long screws may extend to flue pipe and puncture it. If substitute screws are used, they must not exceed 1 1/2" (3.81 cm) in length. It is mandatory that the combustion air and flue tube assembly be properly engaged, and the combustion air pipe fastened to the furnace with sheet metal screws in the holes provided.

If using an optional interior extension, place extension down on furnace top and mate with furnace flue and combustion air collar until it lines up with screw holes in combustion air collar. Secure the extension to the furnace using the pre-punched holes. Use 1/2" (1.27 cm) blunt or sharp end sheet metal screws to fasten roof jack combustion air pipe to furnace combustion air collar. Screw holes are provided in pipe and collar. Excessively long screws may extend to flue pipe and puncture it. If substitute screws are used, they must not exceed 1 1/2" (3.81 cm) in length. Pull the roof jack flue and combustion air pipe assembly down and mate with extension flue and combustion air pipes until the screw holes line up. See Figure 29. Fasten interior extension to combustion air pipe assembly with sheet metal screws not exceeding 1 1/2" (3.81 cm) in length.

IMPORTANT: Under no circumstances shall the connection between the flue and combustion air pipe assembly of the roof jack and the interior extension be above the ceiling line.

Secure the roof jack to the roof with screws. Non-hardening mastic sealer or caulking compound must be used to seal the roof flange to prevent water leakage. The roof jack swivel joint must also be sealed to prevent water leakage.

Secure Roof Jack to Roof

1. Apply caulk or other sealant to underside of Roof Jack flashing.
2. Locate Roof Jack such that pipes are plumb.
3. Secure Roof Jack flashing with nails, screws or staples.
4. Install roofing material over Roof Jack flashing.
5. Seal Roof Jack swivel joint with silicone sealant or other sealant suitable for local weather conditions. Not required for Roof Jacks with fixed slant flashing.

Complete Installation, as required

1. Install Exterior Roof Jack Extension, if applicable. Refer to installation instructions provided with Exterior Roof Jack Extension. Refer to Figure 32.
2. Install Crown Assembly, if applicable. Refer to installation instructions provided with Crown Assembly. If Crown Assembly is not installed, attach warning tags provided with Roof Jack to: Refer to Figure 32.

SWIVEL FLASHING ADJUSTS FROM 0/12 TO 5/12 PITCH	SLANT FLASHING 3/12 PITCH	DFAH FURNACES	DFAA FURNACES
		INSTALLATION DIMENSIONS	INSTALLATION DIMENSIONS
		"A" ADJUSTABLE HEIGHT	"B" ADJUSTABLE HEIGHT
4000-7101/C	4000-6101/A	70" to 79"	86" to 95"
4000-7121/C	4000-6121/A	75" to 86"	91" to 102"
4000-7141/C	4000-6141/A	83" to 104"	99" to 120"
4000-7151/C	4000-6151/A	90" to 116"	106" to 132"
4000-7171/C	4000-6171/A	127" to 157"	143" to 173"

¹ The 4084-7141 is dimensionally the same as 4000-7141/C and is available only in Canada.

² The 4084-7151 is dimensionally the same as 4000-7151/C and is available only in Canada.

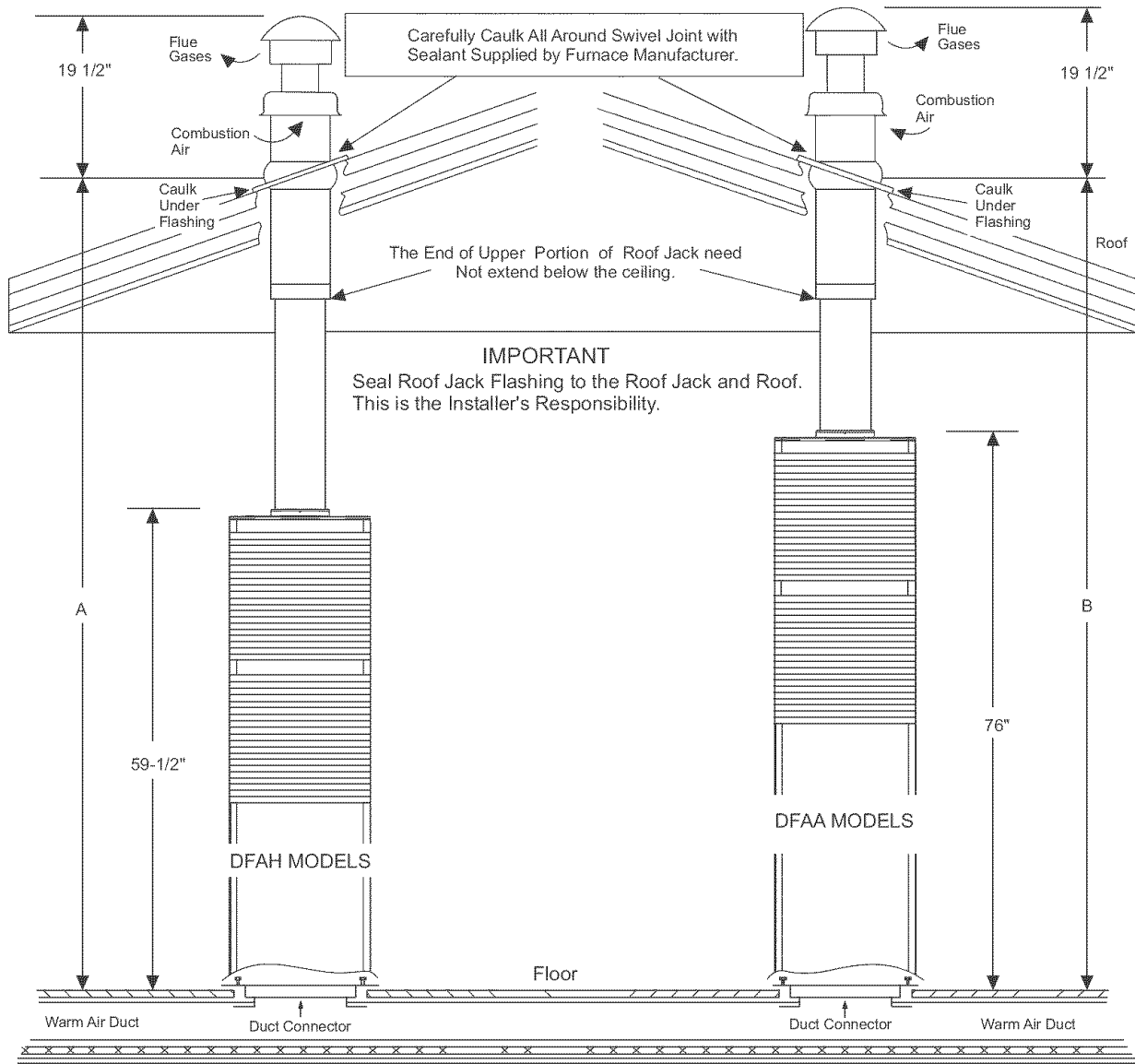

FIGURE 30: Standard Roof Jack

SWIVEL FLASHING ADJUSTS FROM 0/12 TO 5/12 PITCH	SLANT FLASHING 3/12 PITCH	DFAH FURNACES	DFAA FURNACES
		INSTALLATION DIMENSIONS	INSTALLATION DIMENSIONS
		"A" ADJUSTABLE HEIGHT	"B" ADJUSTABLE HEIGHT
4000-8161/C	4000-9161/A	85" to 101"	101" to 117"
4000-8181/C	4000-9181/A	99" to 129"	115" to 145"

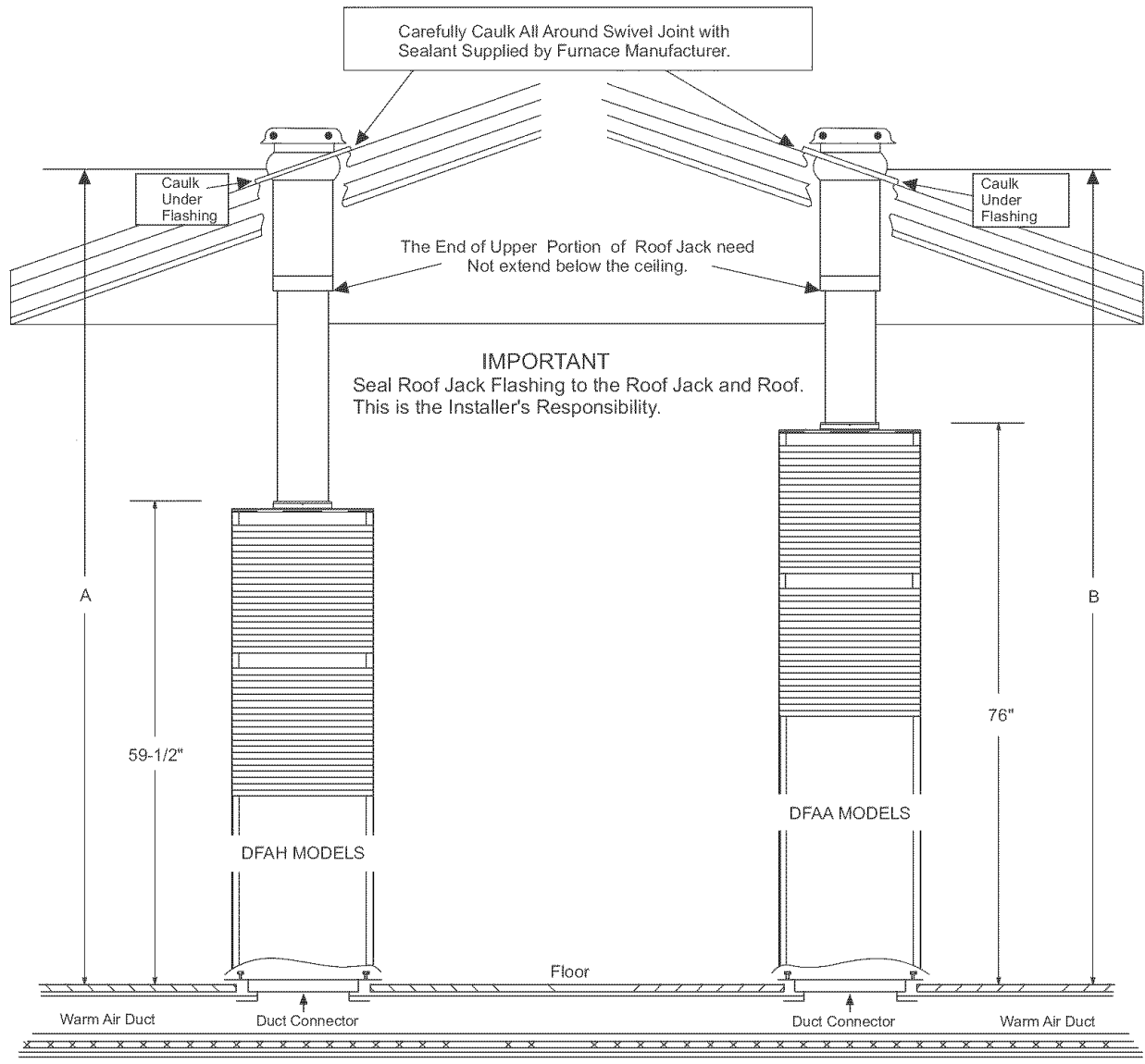

FIGURE 31: Roof Jack With Removable Crowns

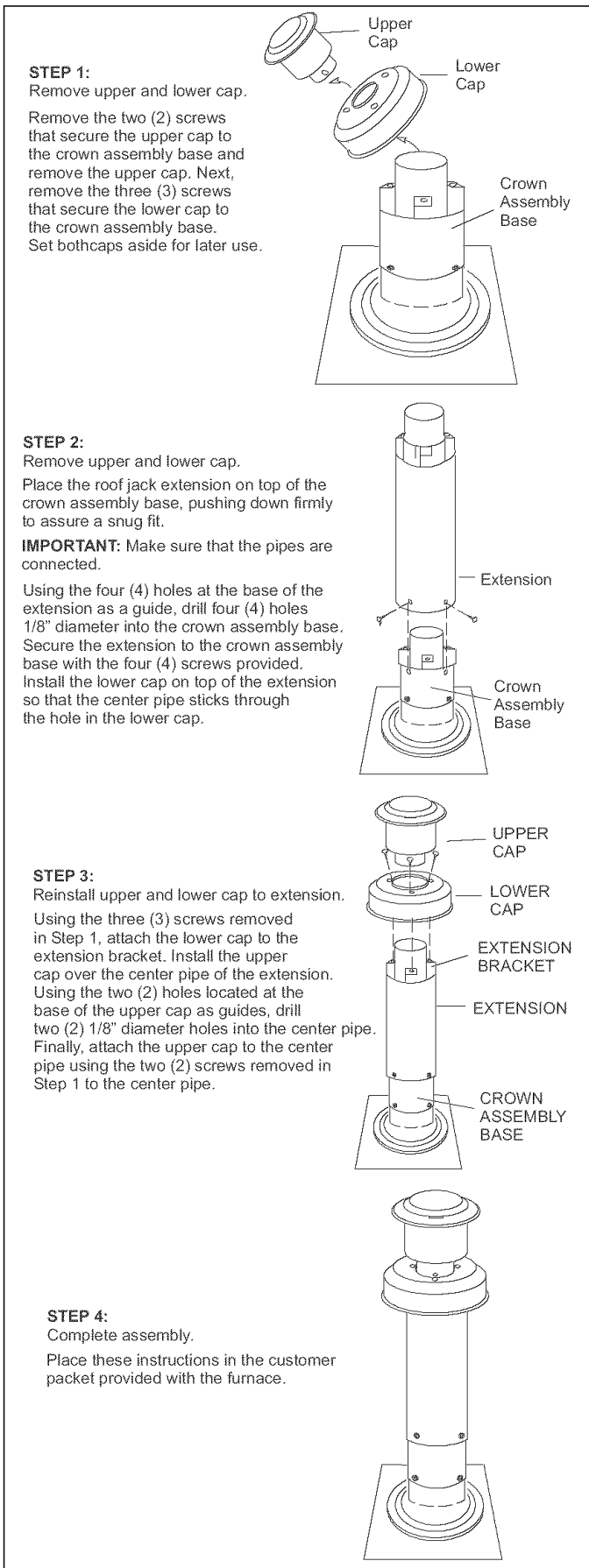

FIGURE 32: Installing Roof Jack Extension

VENT SYSTEM

This furnace is a sealed combustion (direct vent) unit and is design certified to use only a 4000 Series roof jack. These roof jacks are designed to exhaust flue products to the outside.

INSTALLING CEILING RING

The ceiling ring is to meet fire stop requirements. Accessory Ceiling Ring may be installed in Manufactured (mobile) Homes or Modular Homes.

Refer to the UL 311 Standard for Safety for Roof Jacks for Manufactured Homes and Recreational Vehicles; or in Canada use CAN/CSA-Z240 MH Series - 92 (latest edition) or applicable provisions of the state, regional or local building codes and these instructions. The installer must follow approved methods in the above standards and/or codes for a fire stop. If required, the installer may use up to three sections of the Accessory Ring. Refer to Figure 33.

NOTE: A portion of the outer edge of the ceiling ring may be trimmed so the ring will fit between the warm air plenum and roof jack.

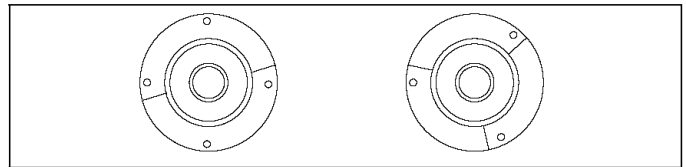

FIGURE 33: Ceiling Ring

VENT CLEARANCES

IMPORTANT: The vent must be installed with the minimum clearances as shown in Figure 34, and must comply with local, state, regional codes and requirements.

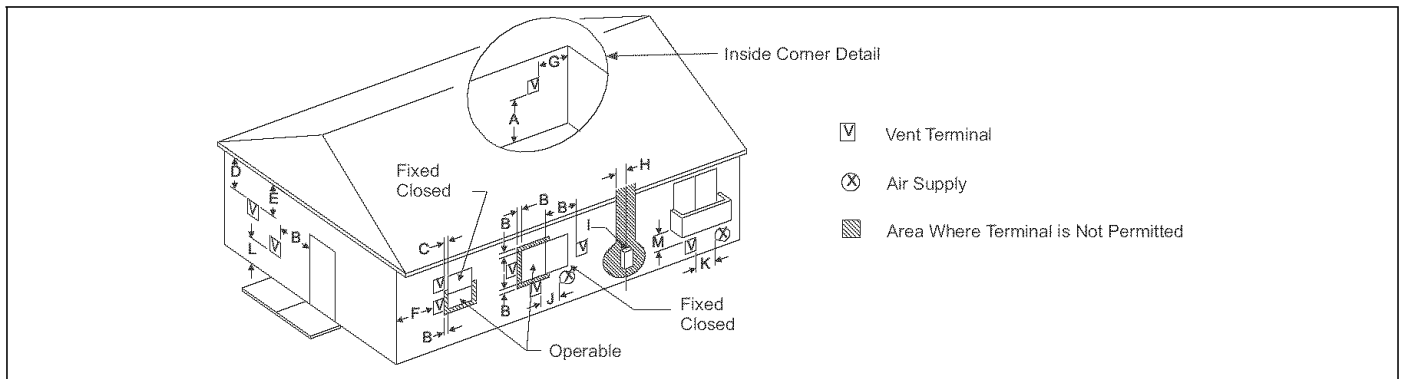

FIGURE 34: Home Layout

	Canadian Installations ¹	US Installation ²
A. Clearance above grade, veranda, porch, deck, or balcony	12 inches (30 cm)	12 inches (30 cm)
B. Clearance to window or door that may be opened	12 inches (30 cm) for models <100,000 BTUH (30 kW), 36 inches (91 cm) for models > 100,000 BTUH (30 kW)	4 Feet
C. Clearance to permanently closed window	4 Feet	4 Feet
D. Vertical clearance to ventilated soffit located above the terminal within a horizontal distance of 2 feet (61 cm) from the center line of the terminal	4 Feet	4 Feet
E. Clearance to unventilated soffit	12 Inches	12 Inches
F. Clearance to outside corner	12 Inches	12 Inches
G. Clearance to inside corner	6 Feet	6 Feet
H. Clearance to each side of center line extended above meter/regulator assembly	3 feet (91 cm) within a height 15 feet (4.5 m) above the meter/regulator assembly	3 feet (91 cm) within a height 15 feet (4.5 m) above the meter/regulator assembly
I. Clearance to service regulator vent outlet	3 feet (91 cm)	3 feet (91 cm)
J. Clearance to nonmechanical air supply inlet to building or the combustion air inlet to any other appliance	12 inches (30 cm) for models <100,000 BTUH (30 kW), 35 inches (91 cm) for models >100,000 BTUH (30 kW)	4 Feet
K. Clearance to a mechanical supply inlet	6 feet (1.83 m)	3 feet (91 cm) above if within 10 feet (3 m) horizontally
L. Clearance above paved sidewalk or paved driveway located on public property	7 feet (2.13 m) †	7 feet (2.13 m) †
M. Clearance under veranda, porch, deck, or balcony	12 inches (30.4 cm)	12 inches (30.4 cm)
Vent Termination from any Building Surface	12" (30.4 cm)	12" (30.4 cm)
Above anticipated snow depth	12" (30.4 cm)	12" (30.4 cm)

1. In accordance with the current CSA B149.1-00, Natural Gas and Propane Installation Code.

2. In accordance with the current ANSI Z223.1 / NFPA 54, National Gas Code. In accordance with the current UL 311 Standard for Safety for Roof Jacks for Manufactured Homes and Recreational Vehicles.

† A vent shall not terminate directly above a sidewalk or paved driveway that is located between two single family dwellings and serves both dwellings.

‡ Permitted only if veranda, porch, deck, or balcony is fully open on a minimum of two sides beneath the floor. For clearance not specified in UL 311 Standard for Safety for Roof Jacks for Manufactured Homes and Recreational Vehicles.

Clearance in accordance with local installation codes and the Manufacturer's Installation Manual.

Any fresh air or make up inlet for dryer or furnace area is considered to be forced air inlet.

Avoid areas where condensate drippage may cause problems such as above planters, patios, or adjacent to windows where steam may cause fogging.

A terminus of a vent shall be either:

Fitted with a cap in accordance with the vent manufacturer's installation instructions, or In accordance with the installation instructions for a special venting system.

* Does not apply to multiple installations of this furnace model. Refer to "VENTING MULTIPLE UNITS" in this section of these instructions.

IMPORTANT: Consideration must be given for degradation of building materials by flue gases. Sidewall termination may require sealing or shielding of building surfaces with a corrosion resistant material to protect against combustion product corrosion. Consideration must be given to wind direction in order to prevent flue products and/or condensate from being blown against the building surfaces. If a metal shield is used it must be a stainless steel material at a minimum dimension of 20" (50.8 cm). It is recommended that a retaining type collar be used that is attached to the building surface to prevent movement of the vent pipe.

Responsibility for the provision of proper adequate venting and air supply for application shall rest with the installer.

Vent shall extend high enough above building, or a neighboring obstruction, so that wind from any direction will not create a positive pressure in the vicinity of the vent. Also in accordance with the current UL 727 Standard for safety for oil-fired central furnaces.

FAN-ASSISTED COMBUSTION SYSTEM

An appliance equipped with an integral mechanical means to either draw or force products of combustion through the combustion chamber and/or heat exchanger.

SECTION VII: SAFETY CONTROLS

CONTROL CIRCUIT FUSE

A 3-amp fuse is provided to protect the 24-volt transformer from over-load caused by control circuit wiring errors. This is an ATO 3, automotive type fuse and is located in the control box.

<p><i>Main power to the unit must still be interrupted at the main power disconnect switch before any service or repair work is to be done to the unit.</i></p> <p><i>Blower and burner must never be operated without the blower panel in place.</i></p>

LIMIT CONTROLS

There is a high temperature limit control located on the furnace vestibule panel near the control box. This is an automatic reset control that provides over temperature protection due to reduced airflow, that may be caused by a dirty filter, or if the indoor fan motor should fail.

INDOOR FAN SWITCH

The indoor fan motor is an operation controlled by normally open temperature actuated switch located above the limit control which is set to close at 110° F (43.3° C) and open at 90° F (32.2° C).

OIL BURNER PRIMARY CONTROL

The R7184A, B, P, U Interrupted Electronic Oil Primary is a line voltage, safety rated, interrupted ignition oil primary control for residential oil fired burners used in forced air furnaces. The R7184A, B, P, U used with a cad cell flame sensor operates an oil burner and optional oil valve. The primary controls fuel oil, senses flame, controls ignition spark and notifies a remote alarm circuit when in lockout.

The indicator light on the oil primary control provides lockout, recycle, and cad cell indications as follows:

1. Flashing at 1/2 second on, 1/2 second off: system is locked out or in restricted mode.

2. Flashing at 2 seconds on, 2 seconds off: control is in recycle mode.
3. On: cad cell is sensing flame.
4. Off: cad cell is not sensing flame.

Cad Cell Resistance Check

For proper operation, it is important that the cad cell resistance is below 1600 ohms. During a normal call for heat, once the control has entered the Run mode, press and release the reset button. See Table 10 for equivalent cad cell resistance.

TABLE 10: Cad Cell Resistance When Sensing Flame

Flashes	Cad Cell Resistance in Ohms
1	Less than 400
2	More than 400 and less than 800
3	More than 800 and less than 1600
4	More than 1600 and less than 5000

Preliminary Steps

1. Check wiring connections and power supply.
2. Make sure power is on to controls.
3. Make sure limit control is closed.
4. Check contacts between ignitor and the electrodes.
5. Check the oil pump pressure.
6. Check the piping to the oil tank.
7. Check the oil nozzle, oil supply and oil filter.

Check Oil Primary Control

If the trouble is not in the burner or ignition hardware, check the oil primary control by using the following equipment:

1. Screwdriver
2. Voltmeter (0 to 150 VAC range)
3. Insulated jumper wire with both ends stripped



<p><i>Electrical Shock Hazard</i></p> <p><i>Can cause severe injury, death or property damage.</i></p> <p><i>Be careful to observe all precautions to prevent electrical shock or equipment damage.</i></p>

TABLE 11: Timings and Settings

Delay Timings ^a			DIP Switch Settings			
Valve-On Delay (seconds)	Burner Motor-Off Delay (minutes)		S-1	S-2	S-3 Enable / Disable	
	R7184U	R7184P			R7184U	R7184P
0	0	—	X	X	Off	b
15	0	0.5	Off	Off	On	
	2	2	Off	On		
	4	4	On	Off		
	5	8	On	On		

X No Difference or Impact

^a Specific models may have different timings. Be sure to check device label.

^b S-3 not provided on R7184P models.

Check / Adjust Electrodes

Check the electrode tip settings. Adjust, if necessary, to comply with the dimensions shown in Figure 35. To adjust, loosen the electrode clamp screw and slide/rotate the electrodes as necessary. Securely tighten the clamp screw when finished.

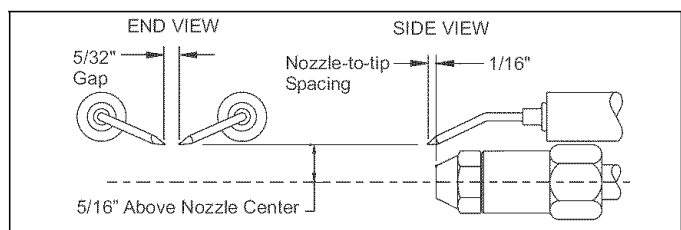

FIGURE 35: Electrode Settings

SPECIFICATIONS

Models:

Table 11 lists the major features and the applicable wiring diagram numbers for the R7184.

Timing:

1. Safe Start Check: 5 seconds (approximately)
2. Valve-on Delay: 15 seconds.
3. Burner motor-off Delay: 0, 2, 4, or 6 minutes. Field selectable using dual in-line programmable (DIP) switch positions 1 and 2. Select models have 0.5, 2, 4, or 8 minute delays.

NOTE: Valve-on delay and burner motor-off delay timings can be enabled (values as listed) or disabled (values are zero) in the field, using DIP switch position 3.

4. Lockout: 15, 30, or 45 seconds (factory-programmed).
5. Recycle: 60 seconds (fixed).
6. Ignition Carryover: 10 seconds (fixed).

Electrical Ratings:

Inputs:

- a. Voltage: 102 to 132 VAC, 120 VAC nominal.
- b. Current: 100 mA plus burner motor, valve and igniter loads.
- c. Frequency: 60 Hz.

Outputs:

- a. Burner: 120 VAC, 10 full load amperes (FLA), 60 locked rotor amperes (LRA).
- b. Valve: 120 VAC, 1A
- c. Igniter: 120 VAC, 360 VA
- d. Alarm: 30 VAC, 2A
- e. Thermostat Current Available: 100mA
- f. EnviraCOM™ Current Available: 150mA

NOTE: Reduce burner FLA rating by igniter load. For example, if the igniter draws 3A (120 VAC, 360 VA), reduce the burner motor FLA to 7A.

SECTION VIII: START-UP AND ADJUSTMENTS

The initial start-up of the furnace requires the following additional procedures:

IMPORTANT: All electrical connections made in the field and in the factory should be checked for proper tightness.

When the oil line is initially connected to the furnace, the tubing may be full of air. In order to purge this air, it is recommended that the bleed valve be loosened until no air bubbles are detected in the plastic tubing. If burner does not light, press the reset button on the primary control once only and bleed oil pump again. If burner still does not light, turn off the power to the furnace and call a qualified service technician. **DO NOT CONTINUE TO PRESS THE RESET BUTTON ON THE PRIMARY CONTROL.**

TOOLS AND INFORMATION THAT WILL BE REQUIRED IN ORDER TO PROPERLY PERFORM THE FURNACE STARTUP PROCEDURE.

1. You will need a thermometer or portable digital thermometer to read the supply and return air temperatures.
2. You will need a pressure gauge that has the ability to read pressures between 0 - 100 PSIG (0 - 689 kPa) in order to measure the oil pump pressures.
3. You will need a 3/32" Allen wrench for the pressure port adjustment screw in the oil pump.
4. You will need 1 piece of 1/4" (0.63 cm) ID flexible tubing that is 12" (30 cm) in length
5. You will need a clear plastic jug.
6. You will need a 7/16" open end or box wrench.
7. You will need a 1/4" brass NPT x flare fitting.

These items are required in order to properly perform the required start-up procedure.

TABLE 12: Burner Specifications

Furnace Model	Burner Spec	ATC	Head	Static Plate	Nozzle	Pump Pressure	Air Boot Setting
DFAA084BBTA DFAH084BBSA	EVC - 201	AF36YHHS	F3	3 - 3/8 U	0.65 x 70° A Delavan	100 psi (689 kPa)	4.0
DFAA066BBTA DFAH066BBSA	EVC - 202	AF36YHHS	F3	3 - 3/8 U	0.50 x 70° A Delavan	100 psi (689 kPa)	3.0

START-UP AND ADJUST BURNER

Start-up Burner / Set Combustion

WARNING

Do not attempt to start the burner when excess fuel or vapor has accumulated in the appliance. Starting the burner under these conditions could result in a puff back of hot combustion gases, high smoke levels, or otherwise hazardous operation.

1. Open the shut-off valves in the oil supply line to the burner.
2. Set the air boot adjustment to the setting stated in Table 12. This is an initial air setting. Additional adjustments must be made with instruments.
3. Set the thermostat substantially above room temperature.
4. Close the line voltage switch to start the burner. If the burner does not start, you may have to reset the safety switch of the burner primary control.
5. Vent air from fuel pump as soon as burner motor starts rotating.
 - To vent the fuel pump, attach a clear plastic hose over the vent plug. Loosen the plug and catch the oil in an empty container. Tighten the plug when all air has been purged from the oil supply system.

- If the burner locks out on safety during venting, quickly close the vent plug, reset the safety switch, open the vent plug when the motor starts rotation, and complete the venting procedure.

NOTE: Electronic safety switches can be reset immediately; others may require a 3 to 5 minute wait.

- If the burner stops after flame is established, additional venting is probably required. Repeat the venting procedure until the pump is primed and a flame is established when the vent plug is closed.
 - For R7184 primary controls, see *Technician's Quick Reference Guide*, Beckett part number 61351, for special pump priming sequence.
 - Prepare for combustion tests by taking a sample in the flue pipe. A combustion sample should be taken with a 1/4" (0.4 cm) tube placed in the center of the vent pipe outside beneath the crown assembly.
6. Initial air adjustment - Using a smoke tester, adjust the air to obtain a clean flame. Now the additional combustion tests with instruments can be made. Never drill a hole in the roof jack to take combustion sample or smoke tests.

IGNITION SYSTEM SEQUENCE

1. Turn the oil supply ON at external valve on the oil pump, and/or at the oil tank.
2. Set the thermostat above room temperature to call for heat.
3. System start-up will occur as follows:
 - a. The burner motor will start and come up to speed.
 - b. Shortly after the burner motor starts-up, the ignition transformer will provide 10,000 volts through the electrodes causing a spark that will last approximately 15 seconds.
 - c. The solenoid valve on the oil pump will open providing oil flow to the nozzle.
 - d. The oil vapor will ignite. The cad cell flame detector will detect the flame. The resistance will drop below 1600 ohms.
 - e. After flame is established, the supply air blower will start when the fan switch reaches approximately 110° F (43.3° C).
 - f. After flame is extinguished, the supply air blower will continue to operate until the air temperature at the fan switch is below 90° F (32.2° C).

▲ WARNING

FIRE OR EXPLOSION HAZARD

Failure to follow the safety warnings exactly could result in serious injury, death or property damage.

Pressing the reset button repeatedly could cause a pool of oil to form in the bottom of the chamber. If ignited, could result in a very dangerous situation which could result in personal injury, property damage, and/or death.

IMPORTANT: Burner ignition may not be satisfactory on first start-up due to residual air in the oil line or until pump pressure is adjusted. The ignition control will make 3 attempts to light before locking out.

The furnace should have a safety or fire shut-off valve connected to the inlet part of the oil pump to shut off the flow of oil in an emergency. Refer to Figure 36 for inlet port location.

ADJUSTMENT OF OIL PUMP PRESSURE

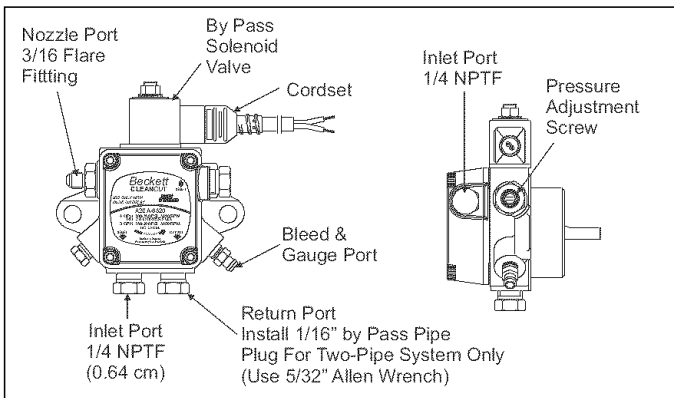

FIGURE 36: Oil Pump

SET COMBUSTION WITH INSTRUMENTS

▲ WARNING

The combustion must be adjusted using test instruments. Failure to do so could result in burner or appliance failure, causing potential severe personal injury, death, or substantial property damage.

1. Let the burner run for approximately 5 to 10 minutes.

2. Set the over-fire or stack draft to level specified by appliance manufacturer (usually -0.01" to -0.02" w.c. (-000024 to -0.0050 kPa) over-fire for natural draft applications).
3. Follow these four steps to properly adjust the burner:
 - a. **Step 1:** Adjust the air until a trace of smoke level is achieved.
 - b. **Step 2:** At the trace of smoke level, measure the CO₂ (or O₂). This is the vital reference point for further adjustments.
 - Example: 13.5% CO₂ (2.6% O₂).
 - c. **Step 3:** Increase the air to reduce CO₂ by 1 to 2 percentage points. (O₂ will be increased by approximately 1.4 to 2.7 percentage points).
 - Example: Reduce CO₂ from 13.5% to 11.5%. (2.6% to 5.3% O₂).
 - d. **Step 4:** Recheck smoke level. It should be zero.
 - This procedure provides a margin of reserve air to accommodate variable conditions.
 - If the draft level has to be changed, recheck the smoke and CO₂ levels. Adjust the burner air if necessary.
4. Once combustion is set, tighten all fasteners on the air adjustment and escutcheon plate.
5. Start and stop the burner several times to ensure satisfactory operation. Test the primary control and all other appliance safety controls to verify that they function according to the manufacturer's specifications.

ADJUSTMENT OF TEMPERATURE RISE

▲ DANGER

The temperature rise, or temperature difference between the return air and the supply (heated) air from the furnace, must be within the range shown on the furnace rating plate and within the application limitations shown in Table 8 "ELECTRICAL AND PERFORMANCE DATA".

The supply air temperature cannot exceed the "Maximum Supply Air Temperature" specified in these instructions and on the furnace rating plate. Under NO circumstances can the furnace be allowed to operate above the Maximum Supply Air Temperature. Operating the furnace above the Maximum Supply Air Temperature will cause premature heat exchanger failure, high levels of Carbon Monoxide, a fire hazard, personal injury, property damage, and/or death.

After about 20 minutes of operation, determine the furnace temperature rise. Take readings of both the return air and the heated air in the ducts, about six feet (1.83 m) from the furnace where they will not be affected by radiant heat.

FILTER PERFORMANCE

The airflow capacity data published in Table 14 represents blower performance WITH CLEAN filters.

The filter pressure drop values in Table 13 are typical values for the type of filter listed and should only be used as a guideline. Actual pressure drop ratings for each filter type vary between filter manufacturers.

DO NOT USE Pleated Media or Hogs Hair filters on this furnace.

Be sure to check for leaks in the oil line and fittings. A leak will cause oil pump to loose it's prime. Repair leaks before continuing with the final adjustments to the oil burner.

TABLE 13: Filter Performance - Pressure Drop Inches W.C. and (kPa)

Airflow Range		Minimum Opening Size		Filter Type Disposable	
		1 Opening		1 Opening	
CFM	Cm/m	ln ²	m ²	inwc	kPa
1001 - 1250	28.35 - 35.40	488	45.34	0.1	0.0249
1251 - 1500	35.42 - 42.47	488	45.34	0.1	0.0249

APPLYING FILTER PRESSURE DROP TO DETERMINE SYSTEM AIRFLOW

Example: For a 84,000 BTUH (38.06 kW) furnace with 1 return openings and operating on high-speed blower, it is found that total system static is 0.30" w.c. (0.075 kPa). To determine the system airflow, complete the following steps:

Obtain the airflow values at 0.10 w.c. (125 Pa) & 0.20 w.c. (150 Pa) ESP.

Airflow @ 0.10": 1175 CFM (60.17 m³/min)

Airflow @ 0.20": 1110 CFM (57.62 m³/min)

Subtract the airflow @ 0.10 w.c. (125 Pa) from the airflow @ 0.20 w.c. (150 Pa) to obtain airflow difference.

1175 - 1110 = -65 CFM (2.55 m³/min)

Subtract the total system static from 0.10 w.c. (125 Pa) and divide this difference by the difference in ESP values in the table, 0.20 w.c. (150 Pa) - 0.10 w.c. (125 Pa), to obtain a percentage.

$(0.30 - 0.10) / (0.20 - 0.10) = 0.5$

Multiply percentage by airflow difference to obtain airflow reduction.

$(0.5) \times (-65) = -32.5$

Subtract airflow reduction value to airflow @ 0.10 w.c. (125 Pa) to obtain actual airflow @ 0.30 wc (144 Pa) ESP.

$1050 - 32.5 = 1017.5$

FINAL PROCEDURE

Install Furnace Doors

Install the lower door first by sliding the bottom of the door down until the tabs on the casing base engage the slots in the bottom door end cap. Then push the top of the lower door in until the door clips snap into place. Install the upper door in a similar manner, first engaging the slots in the top of the upper door on the tabs on the casing top. Then snap the bottom of the upper door into place against the casing.

Finish and Trim

Alcove and Closet Installations may now be finished and trimmed as necessary.

TABLE 14: Blower Performance CFM

BLOWER PERFORMANCE CFM - DFAA066 FACTORY EQUIPPED WITH STANDARD BLOWERS AND FILTERS												
Blower Speed	BTU/H (kW) Input / Output	CFM (m ³ / min)	EXTERNAL STATIC PRESSURE, INCHES WC (kPa)									
			0.1 (0.025)		0.2 (0.050)		0.3 (0.075)		0.4 (0.099)		0.5 (0.124)	
			cfm	cm/m	cfm	cm/m	cfm	cm/m	cfm	cm/m	cfm	cm/m
Single Speed - No Coil	66(19.34) / 53(15.55)	1050(29.73)	1175	33.3	1110	31.4	1050	29.7	1000	28.3	950	26.9
Single Speed - With Dry Coil	66(19.34) / 53(15.55)	1050(29.73)	1125	31.9	1070	30.3	1020	28.9	960	27.2	910	25.8
BLOWER PERFORMANCE CFM - DFAA084												
Blower Speed	BTU/H (kW) Input / Output	CFM (m ³ / min)	EXTERNAL STATIC PRESSURE, INCHES WC (kPa)									
			0.1 (0.025)		0.2 (0.050)		0.3 (0.075)		0.4 (0.099)		0.5 (0.124)	
			cfm	cm/m	cfm	cm/m	cfm	cm/m	cfm	cm/m	cfm	cm/m
Single Speed - No Coil	84(24.62) / 67(19.63)	1250(35.39)	1370	38.8	1305	37.0	1245	35.3	1175	33.3	1100	31.1
Single Speed - With Dry Coil	84(24.62) / 67(19.63)	1250(35.39)	1265	35.8	1195	33.8	1120	31.7	1045	29.6	1015	28.7
BLOWER PERFORMANCE CFM - DFAH066												
Blower Speed	BTU/H (kW) Input / Output	CFM (m ³ / min)	EXTERNAL STATIC PRESSURE, INCHES WC (kPa)									
			0.1 (0.025)		0.2 (0.050)		0.3 (0.075)		0.4 (0.099)		0.5 (0.124)	
			cfm	cm/m	cfm	cm/m	cfm	cm/m	cfm	cm/m	cfm	cm/m
Single Speed - No Coil	66(19.34) / 53(15.55)	1050(29.73)	1155	32.7	1111	31.5	1055	29.9	995	28.2	920	26.1
BLOWER PERFORMANCE CFM - DFAH084												
Blower Speed	BTU/H (kW) Input / Output	CFM (m ³ / min)	EXTERNAL STATIC PRESSURE, INCHES WC (kPa)									
			0.1 (0.025)		0.2 (0.050)		0.3 (0.075)		0.4 (0.099)		0.5 (0.124)	
			cfm	cm/m	cfm	cm/m	cfm	cm/m	cfm	cm/m	cfm	cm/m
Single Speed - No Coil	84(24.62) / 67(19.63)	1250(35.39)	1127	31.9	1062	30.1	1005	28.5	952	27.0	887	25.1

NOTES:

1. Airflow expressed in standard cubic feet per minute (cfm) and in cubic meters per minute (cm/m)
2. Return air is through louvered filter door only.
3. Motor voltage at 115V

TABLE 15: Replacement Parts - Non Electrical

DFAA MODEL	
ITEM NUMBER	DESCRIPTION
1	Limit Switch, Manual (Upper)
2	Thermostat (Heat/Cool)
3	Exchanger, Heat (w/Gaskets)
4	Switch, Rocker (System)
5	Transformer (115 - 24V, 40 VA)
6	Filter (16 x 20 x 1) (2Required)
7	Panel, Door (Upper)
8	Panel, Door (Lower, Tall)
9	Motor
10	Plug, Connector
11	Capacitor, Run
12	Wheel, Blower
13	Blower, AC Relay
14	Switch, Fan
15	Combustion Chamber Assembly
16	Oil Burner Assembly
17	Switch, Limit (Open 140 - Close 110)
18	Fastener, Door Latch (2 Required)
19	Diagram, Wiring

DFAH MODEL	
ITEM NUMBER	DESCRIPTION
1	Limit Switch, Manual (Upper)
2	Thermostat (Heat Only)
3	Exchanger, Heat (w/Gaskets)
4	Switch, System
5	Transformer (115 - 24V, 40 VA)
6	Filter (16 x 20 x 1) (2 Required)
7	Panel, Door (Upper)
8	Panel, Door (Lower, Short)
9	Motor
10	Plug, Connector
11	Capacitor, Run
12	Wheel, Blower
13	Blower, AC Relay
14	Switch, Fan
15	Combustion Chamber Assembly
16	Oil Burner Assembly
17	Switch, Limit (Open 140 - Close 110)
18	Fastener, Door Latch (2 Required)
19	Diagram, Wiring

FIGURE 37: Wiring Diagram for DF8A - Oil-Fired Furnace

BLOWER SPEED CHART
(CHARTRE DE VITESSE
DE LA SOUFFLERIE)

INPUT (ENTREE)	CFM (PCM)	HEAT/COOL (CHAUF/CLIMA)
086	1050	BLK (NOIR)
084	1245	BLK (NOIR)

WIRE COLOR KEY
(CODE DE COULEUR
DU FILAGE)

BLK (NOIR)	BLACK (NOIR)
BLU (BLEU)	BLUE (BLEU)
RED (ROUGE)	RED (ROUGE)
YEL (JAUN)	YELLOW (JAUNE)
WHT (BLANC)	WHITE (BLANC)
BRN (BRUN)	BROWN (BRUN)
GRN (VERT)	GREEN (VERT)
PRP (POURPRE)	PURPLE (POURPRE)
ORG (ORA)	ORANGE (ORANGE)

- CAUTION -
OPEN ALL DISCONNECTS BEFORE
SERVICING THIS UNIT

- PRECAUTION -
OUVREZ LES DISJONCTEURS AVANT
DE PROCÉDER AVEC LE SERVICE

80+ DOWNFLOW FURNACE
(FOURNAISE 80%
VENTILEE PAR LE HAUT)

NOTES:

1. TOUT FILAGE EN CHANTIER SELON: (A) CODE ELEC. NATIONAL (CEN) ET/OU/ (B) CODE ELEC. CANADIEN (CEC) ET/OU/ (C) CODES LOCAUX ET MUNICIPAUX.
2. SI LE FILAGE DOIT ÊTRE REMPLACÉ EN PATRIE OU EN TOUT, IL DOIT L'ÊTRE AVEC UN MATÉRIEL POUVANT RESISTER A DES TEMPÉRATURES D'AU MOINS 221°F (105°C).
3. SEULEMENT DES MARETTES POUR FIL DE CUIVRE.
4. TOUTE COMPOSANTE DE REMPLACEMENT DOIT ÊTRE BIEN MISE EN TERRE.
5. FOURNISSEZ LES DISJONCTEURS POUR L'ALIMENTATION.
6. LES MOTEURS SONT PROTÉGÉS DE PAR LEUR CONCEPTION.

LEGEND

- BM OIL BURNER MOTOR
- OPSV OIL PUMP SOLENOID VALVE
- OBPC OIL BURNER PRIMARY CONTROL
- IT IGNITION TRANSFORMER
- CC CAD CELL FLAME SENSOR
- SV SOLENOID VALVE
- PC PRIMARY CONTROL
- PI/SI 9 PIN PLUG & SOCKET ON BLOWER MOTOR
- LS1 PRIMARY LIMIT SWITCH
- LS2 OIL BURNER LIMIT SWITCH
- FS FAN SWITCH (RIGHT SIDE)
- FUSE FUSIBLE
- IRC RUN CAPACITOR
- IT TRANSFORMER
- ⊗ IDENTIFIED RUN CAPACITOR
- ⊗ 24V CONNECTION ROOM THERMOSTAT
- FIELD CONNECTION
- FACTORY WIRING AND DEVICES
- FIELD WIRING AND DEVICES

LADDER DIAGRAM
(DIAGRAMME ÉLÉMENTAIRE)

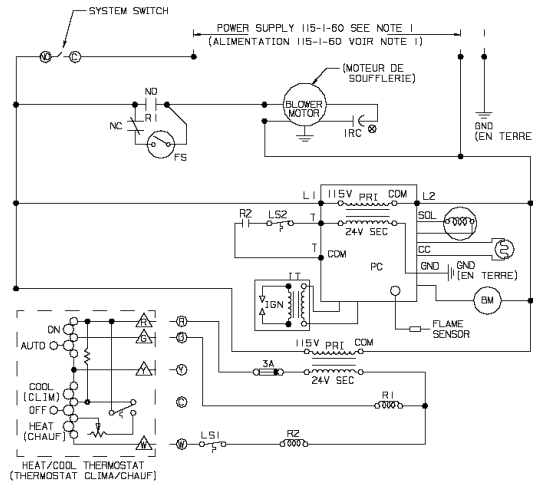

NOTES:

1. ALL FIELD WIRING PER: (A) NATIONAL ELEC. CODE (NEC) AND/OR/ (B) CANADIAN ELEC. CODE (CEC) AND/OR/ (C) LOCAL OR CITY CODES.
2. IF ANY OF THE ORIGINAL WIRE AS SUPPLIED WITH THE FURNACE MUST BE REPLACED, IT MUST BE REPLACED WITH WIRING MATERIAL HAVING A TEMPERATURE RATING OF AT LEAST 221°F (105°C).
3. CONNECTORS SUITABLE FOR COPPER CONDUCTORS ONLY.
4. ALL REPLACEMENT COMPONENTS MUST BE PROPERLY GROUNDED.
5. PROVIDE DISCONNECTS FOR ALL POWER SUPPLIES.
6. MOTORS ARE INHERENTLY PROTECTED.

LEGENDE

- BM DU BRULEUR A L'HUILE MOTEUR
- OPSV SOLENOÏDE DE LA POMPE A L'HUILE SOUPAPE
- OBPC CONTRÔLE PRIMAIRE DU BRULEUR A L'HUILE
- IT TRANSFORMATEUR D'IGNITION
- CC FLAMME DE LA CELLULE CAD CAPTEUR DE
- SV SOUPE DU SOLENOÏDE
- PC CONTRÔLE PRIMAIRE
- PI/SI LE MOTEUR DE LA SOUFFLERIE DOUILLE ET BOUCHON A 9 PIGES SUR
- LS1 COMMUTATEUR DE LIMITE PRINCIPALE
- LS2 DE LIMITE DU BRULEUR A L'HUILE COMMUTATEUR
- FS COMMUTATEUR DU VENTILATEUR (COTE DROIT)
- FUSIBLE FUSIBLE
- IRC CAPACITEUR DE FONCTIONNEMENT IDENTIFIE
- IT TRANSFORMEUR
- ⊗ CAPACITEUR DE FONCTIONNEMENT IDENTIFIE
- ⊗ 24V RACCORDEMENT DU THERMOSTAT DE PIECE
- RACCORDEMENT DE CHANTIER
- FILAGE DE L'USINE ET APPAREILS
- FILAGE DE CHANTIER ET APPAREILS

CONNECTION DIAGRAM
(DIAGRAMME DE RACCORDEMENT)

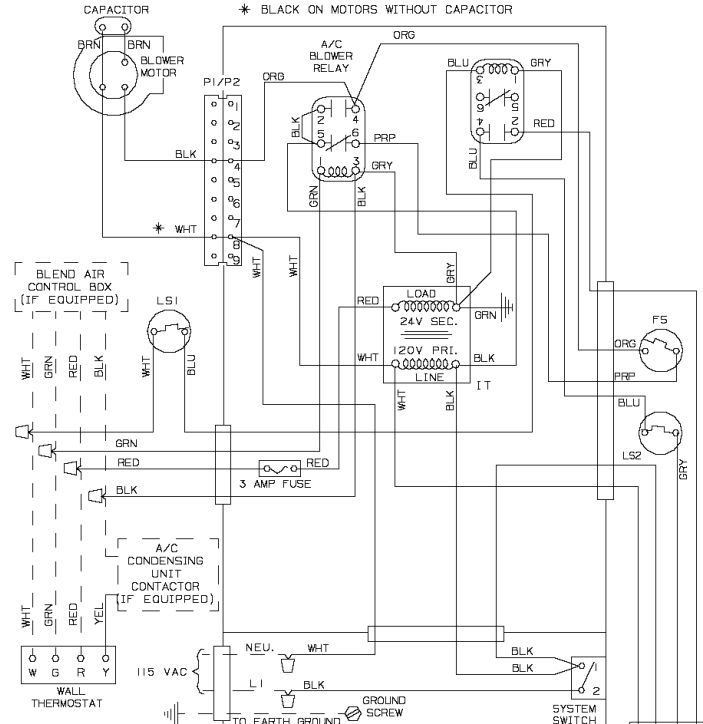

INCOMING POWER MUST BE POLARIZED, OBSERVE COLOR CODING.
L'ALIMENTATION DU COURANT DOIT ÊTRE POLARISÉE. SUIVEZ
LES CODES DE COULEURS.

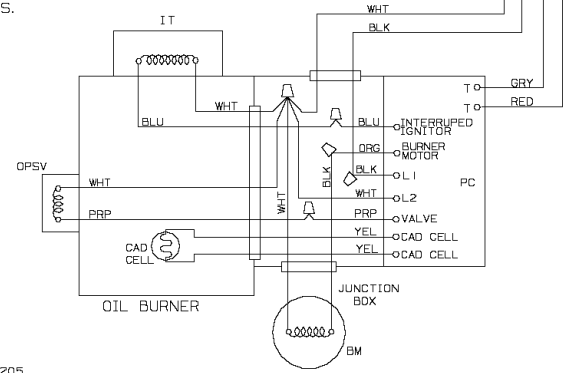

107466-UWD-A-0205

FIGURE 38: Wiring Diagram for DFAH - Oil Furnace

BLOWER SPEED CHART
(CHARTRE DE VITESSE
DE LA SOUFFLERIE)

INPUT (ENTREE)	CFM (PCM)	HEAT/COOL (CHAU/CLIMA)
066	1050	BLK (NOIR)
084	1245	BLK (NOIR)

WIRE COLOR KEY
(CODE DE COULEUR
DU FILAGE)

BLK (NOIR)	BLACK (NOIR)
BLU (BLEU)	BLUE (BLEU)
RED (ROUGE)	RED (ROUGE)
YEL (JAUN)	YELLOW (JAUNE)
WHT (BLANC)	WHITE (BLANC)
BRN (BRUN)	BROWN (BRUN)
GRN (VERT)	GREEN (VERT)
PRP (POURPRE)	PURPLE (POURPRE)
ORN (ORA)	ORANGE (ORANGE)

- CAUTION -
OPEN ALL DISCONNECTS BEFORE
SERVICING THIS UNIT
- PRECAUTION -
OUVREZ LES DISJONCTEURS AVANT
DE PROCÉDER AVEC LE SERVICE

80+ DOWNFLOW FURNACE
(FOURNAISE 80%
VENTILEE PAR LE HAUT)

NOTES:

1. TOUT FILAGE EN CHANTIER SELON: (A) CODE ELEC. NATIONAL (CEN) ET/OU/ (B) CODE ELEC. CANADIEN (CEC) ET/OU/ (C) CODES LOCAUX ET MUNICIPAUX.
2. SI LE FILAGE DOIT ÊTRE REMPLACÉ EN PATRIE OU EN TOUT, IL DOIT L'ÊTRE, AVEC UN MATÉRIEL POUVANT RÉSISSER À DES TEMPÉRATURES D'AU MOINS 221°F (105°C).
3. SEULEMENT DES MARETTES POUR FIL DE CUIVRE.
4. TOUTE COMPOSANTE DE REMPLACEMENT DOIT ÊTRE BIEN MISE EN TERRE.
5. FOURNISSEZ LES DISJONCTEURS POUR L'ALIMENTATION.
6. LES MOTEURS SONT PROTÉGÉS PAR LEUR CONCEPTION.

LEGEND

- BM BURNER MOTOR
- PC PRIMARY CONTROL
- IT IGNITION TRANSFORMER
- RI RELAY
- SV SOLENOID VALVE
- PC PRIMARY CONTROL
- PI/SI 9 PIN PLUG & SOCKET ON BLOWER MOTOR
- LS1 PRIMARY LIMIT SWITCH
- LS2 LIMIT SWITCH
- CS CENTRIFUGAL SWITCH
- FUSE
- IRC RUN CAPACITOR
- IT TRANSFORMER
- ⊗ IDENTIFIED RUN CAPACITOR
- △ 24V CONNECTION ROOM THERMOSTAT
- FIELD CONNECTION
- FACTORY WIRING AND DEVICES
- CHANTIER WIRING AND DEVICES

LADDER DIAGRAM
(DIAGRAMME ÉLÉMENTAIRE)

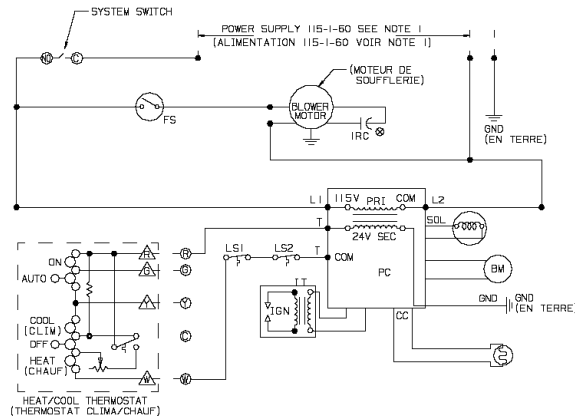

NOTES:

1. ALL FIELD WIRING PER: (A) NATIONAL ELEC. CODE (NEC) AND/OR/ (B) CANADIAN ELEC. CODE (CEC) AND/OR/ (C) LOCAL OR CITY CODES.
2. IF ANY OF THE ORIGINAL WIRE AS SUPPLIED WITH THE FURNACE MUST BE REPLACED, IT MUST BE REPLACED WITH WIRING MATERIAL HAVING A TEMPERATURE RATING OF AT LEAST 221°F (105°C).
3. CONNECTORS SUITABLE FOR COPPER CONDUCTORS ONLY.
4. ALL REPLACEMENT COMPONENTS MUST BE PROPERLY GROUNDED.
5. PROVIDE DISCONNECTS FOR ALL POWER SUPPLIES.
6. MOTORS ARE INHERENTLY PROTECTED.

LEGENDE

- BM MOTEUR DU BRÛLEUR
- PC CONTRÔLE PRIMAIRE
- IT TRANSFORMATEUR D'IGNITION
- RI RELAIS
- SV SOUPE DU SOLENOÏDE
- PC CONTRÔLE PRIMAIRE
- PI/SI LE MOTEUR DE LA SOUFFLERIE DOUILLE ET BOUCHON A 9 PIGES SUR
- LS1 COMUTATEUR DE LIMITE PRINCIPALE
- LS2 COMUTATEUR DE LIMITE
- CS COMUTATEUR CENTRIFUGUE
- FUSIBLE
- IRC CAPACITEUR DE FONCTIONNEMENT IDENTIFIE
- IT TRANSFORMEUR
- ⊗ CAPACITEUR DE FONCTIONNEMENT IDENTIFIE
- △ 24V RACCORDEMENT DU THERMOSTAT DE PIECE
- RACCORDEMENT DE CHANTIER
- FILAGE DE L'USINE ET APPAREILS
- FILAGE DE CHANTIER ET APPAREILS

IF ANY OF THE ORIGINAL WIRE SUPPLIED WITH THIS UNIT MUST BE REPLACED, IT MUST BE REPLACED WITH TYPE 105°C THERMOPLASTIC OR ITS EQUIVALENT.

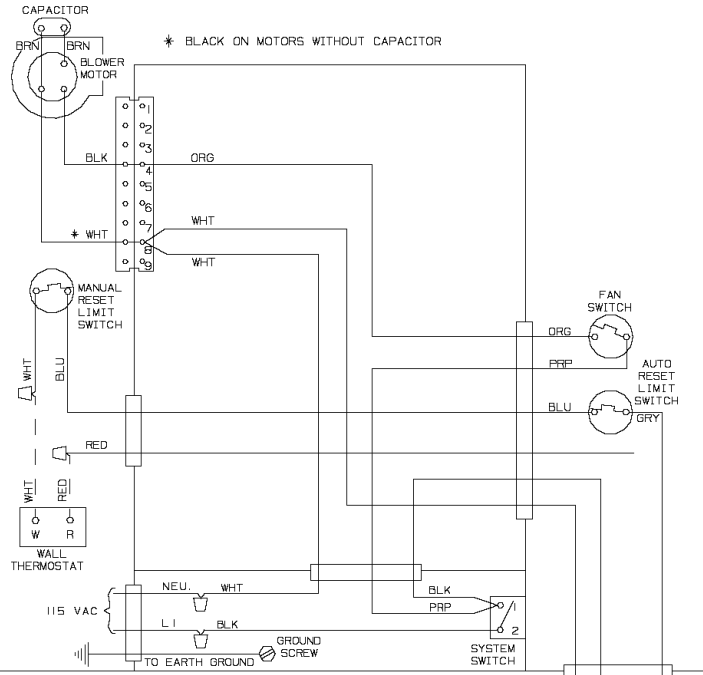

INCOMING POWER MUST BE POLARIZED. OBSERVE COLOR CODING.
L'ALIMENTATION DU COURANT DOIT ÊTRE POLARISEE. SUIVEZ
LES CODES DE COULEURS.

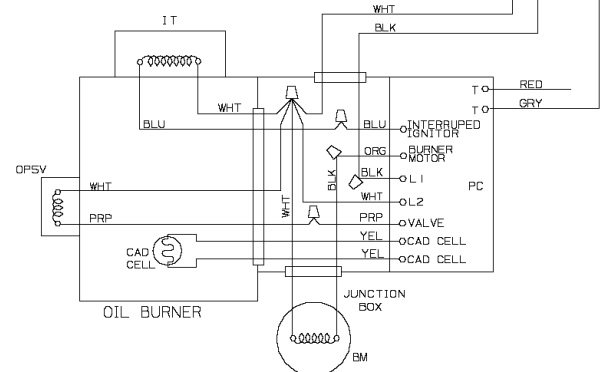

15B931-UWD-A-0705

SECTION X: GAS GUN BURNER

These instructions were prepared for the guidance of those installing this particular gas conversion burner. While they apply in principle to all installations, they should not be interpreted as meaning the only safe and economical way to install a conversion burner. It may be necessary to deviate from these instructions in some instances in order to comply with local gas company rules or codes in effect in the area in which the installation is made. It is recommended that the installer confer with the local gas company and with the proper municipal officials regarding any specific code or regulation governing the installation of gas conversion burners, the installation must conform with local codes or, in the absence of local codes, with the American National Standard Installation of Domestic Gas Conversion Burners, Z21.8 latest edition, and the National Fuel Gas Code, ANSI Z223.1-latest edition.

Safe and economical operation of the burner throughout its service life is dependent to a large extent upon its proper installation in the heating appliance. Therefore, we may impress upon the installer that good clean workmanlike installations mean satisfied customers.

PREPARATION OF COMBUSTION CHAMBER

The power gas burner is designed for "inshot" firing into a refractory lined combustion chamber constructed in the furnace originally designed for oil firing.

When converting oil designed furnaces, it is recommended that the same combustion chamber be used with the oil burner. If the blast tube opening into the combustion chamber is larger than the 4" (101.6 mm) diameter, high temperature cement should be used to reduce the opening to 4" (101.6 mm) diameter.

IN NO CASE SHOULD THE TUBE BE ALLOWED TO EXTEND INTO THE CHAMBER. IT MUST BE AT LEAST 1/8" (3.175mm) SHORT OF THE INSIDE SURFACE OF THE COMBUSTION CHAMBER.

COMBUSTION CHAMBER

The chamber is very fragile. DO NOT come in contact with the chamber with the vacuum cleaner hose. The suction from the hose will create a hole in the chamber. Hold hose at an angle when vacuuming chamber.

INSTALLATION OF BURNER AND CONTROLS

The inshot power gas burner was designed especially for converting gun fired oil designed furnaces. Due consideration was given to making it as simple and easy to install and service as possible without weakening its durability or efficiency. The burner is supplied as a completely assembled package unit.

NOTE: The burner must be installed in such a manner that the unit and all controls will be readily accessible for inspection, cleaning, adjustment, and repairs.

▲ DANGER

This conversion burner is designed to operate on NATURAL GAS or PROPANE GAS ONLY. Do Not Burn any other Fuel in this furnace. Burning any fuel except NATURAL GAS or PROPANE GAS can cause premature heat exchanger burnout, high levels of carbon monoxide, excessive sooting, a fire hazard, personal injury, property damage and /or death.

▲ DANGER

An overpressure protection device, such as a pressure regulator, must be installed in the gas piping system upstream of the furnace and must act to limit the downstream pressure to the gas valve so it does not exceed 0.5 PSI (14" w.c. (3.48 kPa)). Pressures exceeding 0.5 PSI (14" w.c. (3.48 kPa)) at the gas valve will cause damage to the gas valve, resulting in a fire or explosion or cause damage to the furnace or some of its components that will result in property damage and loss of life.

GAS PIPING

Installation and Checking of Gas Line

Gas Supply piping must be sized in accordance with the recommendations contained in National Fuel Gas Code (ANSI-Z223.1, NFPA-54) unless local codes or regulations state otherwise.

Materials used and pipe sizing for U.S. manufactured (mobile) homes must comply with requirements contained in Manufactured Homes A119.1, Recreational Vehicles A119.2 and H.U.D. Title 24, Section 3280.705 and any local or state codes.

NOTE: The gas line inlet on the gas valve is 1/2-14 N.P.T. The gas line may be installed through the furnace floor or either side of the furnace to the gas valve.

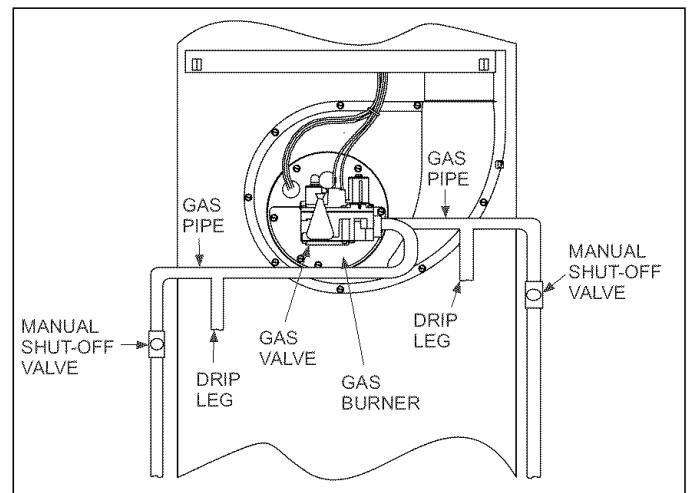

FIGURE 39: Gas Piping

▲ CAUTION

The gas valve body is a very thin casting that cannot take any external pressure. Never apply a pipe wrench to the body of the gas valve when installing piping. A wrench must be placed on the octagon hub located on the gas inlet side of the valve. Placing a wrench to the body of the gas valve will damage the valve causing improper operation and/or the valve to leak. Refer to Figure 42.

The gas line should be a separate supply direct from the meter to the gas valve. It is recommended that new pipe be used and located so that a minimum amount of work will be required in future servicing. The piping should be so installed as to be durable, substantial and gas tight. It should be clear and free from cutting burrs and defects in structure or threading. Cast iron fittings or aluminum tubing should not be used for the main gas circuit. Joint compounds (pipe dope) should be used sparingly on male threads only and be approved for all gases. Refer to Figures 39, 40 & 41.

It is recommended that the pipe diameter in Table 16 be used to determine the size pipe to use from the meter to the burner.

TABLE 16: Gas Line Piping Size and Length

Length of Pipe in Feet (Meter)	Nominal Diameter of Pipe in Inches (mm)				
	3/4 (19.05)	1 (25.4)	1-1/4 (31.75)	1-1/2 (38.1)	2 (50.8)
	Capacity-Cu. Ft. (m ³) Per Hr. with a 0.6 Sp. Gr. Gas and Pressure Drop of 0.3 in. (74.72 Pa) Water Col.				
15 (4.572)	172 (4.87)	345 (9.77)	750 (21.24)	—	—
30 (9.144)	120 (3.4)	241 (6.82)	535 (15.15)	850 (24.07)	—
45 (13.72)	99 (2.8)	199 (5.64)	435 (12.32)	700 (19.82)	—
60 (18.29)	86 (2.44)	173 (4.90)	380 (10.76)	610 (17.27)	—
75 (22.86)	77 (2.18)	155 (4.34)	345 (9.77)	545 (15.43)	—
105 (32)	65 (1.84)	131 (3.71)	285 (8.07)	450 (12.74)	920 (26.05)
120 (36.58)	—	120 (3.4)	270 (7.65)	420 (11.89)	860 (24.35)
180 (54.86)	—	100 (2.83)	225 (6.37)	350 (10.76)	720 (20.39)

The building structure should not be weak end by installation for the gas piping. The piping should not be supported by the other piping, but should be firmly supported with pipe hooks, straps, bands, or hanger. Butt or lap welded pipe should not be bent.

The gas piping should be so installed so as to prevent an accumulation of condensation and it must be protected against freezing. A horizontal pipe should be pitched so that it grades toward the meter and is free from sags. The pipe can not be run through or in an air duct or clothes chute.

The appliance and its individual shut-off valve must be disconnected from the gas supply piping system during any pressure testing of the system at test pressure in excess of 1/2 (3447 PaG) psig.

The appliance must be isolated from the gas supply piping system by closing its individual manual shut-off valve during any pressure testing of the gas supply piping system at test pressures equal to or less than 1/2 (3447 PaG) psig. Refer to Figure 40.

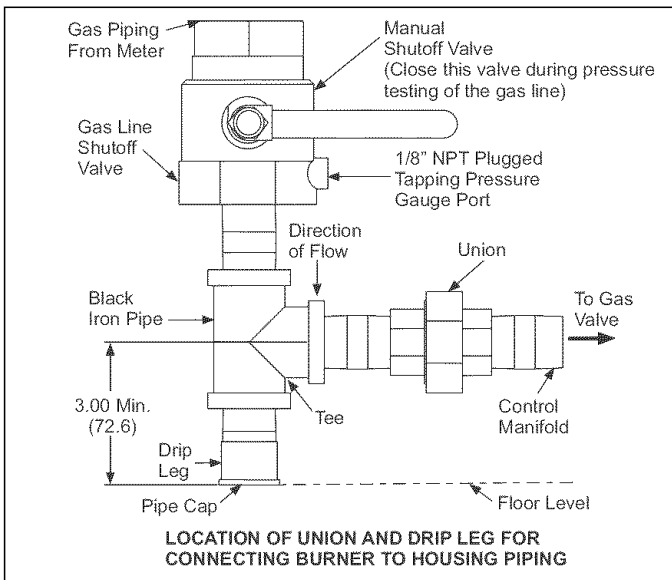

FIGURE 40: Manual Shut-off Valve/Gas Piping

GAS PIPING INSTALLATION

Properly sized wrought iron, approved flexible or steel pipe must be used when making gas connections to the unit. If local codes allow the use of a flexible gas appliance connection, always use a new listed connector. Do not use a connector that has previously serviced another gas appliance.

Some utility companies or local codes require pipe sizes larger than the minimum sizes listed in these instructions and in the codes. The furnace rating plate and the instructions in this section specify the type of gas approved for this furnace - only use those approved gases.

IMPORTANT: An accessible manual shut-off valve must be installed upstream of the furnace gas valve and within 6 feet (1.8 m) of the furnace.

TESTING PIPING FOR LEAKS

Before turning on gas under pressure into piping, all openings from which gas can escape should be closed. Immediately after turning on gas, the system should be checked for leaks. This can be done by watching the 1/2 cubic feet (0.14 m³) test dial and allowing 5 minutes to show any movement, or by soaping each pipe connection and watching for bubbles. If a leak is found, make the necessary repairs and repeat the above test.

DEFECTIVE PIPES OR FITTINGS SHOULD BE REPLACED AND NOT REPAIRED. NEVER USE A FLAME OR FIRE IN ANY FORM TO LOCATE GAS LEAKS, USE A SOAP SOLUTION.

TABLE 17: Length of Standard Pipe Threads in Inches (mm)

PIPE SIZE	EFFECTIVE LENGTH OF THREAD	OVERALL LENGTH OF THREAD
3/8 (9.53)	3/8 (9.53)	9/16 (14.29)
1/2 (12.7)	1/2 (12.7)	3/4 (19.05)
3/4 (19.05)	1/2 - 9/16 (14.29)	13/16 (20.64)
1 (25.4)	9/16 (14.29)	1 (25.4)

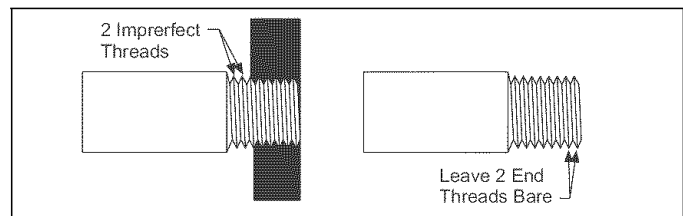

FIGURE 41: Proper Piping Practice

CAUTION

If the gas input to the furnace is too great because of excessive gas pressure, wrong size orifice, high altitude, etc., the burner flame will be sooty and may produce carbon monoxide, which could result in unsafe operation, explosion, and/or fire or asphyxiation.

CAUTION

To install gas line and to connect it to the gas valve, care must be taken to hold gas valve firmly to prevent misalignment of the burner orifice, or to damage gas valve which could result in improper heating, explosion, fire or asphyxiation.

DO NOT USE EXCESSIVE PIPE SEALANT ON PIPE JOINTS. Pipe sealant, metal chips or other foreign material that could be deposited in the inlet of the gas valve, when gas pipe is installed or carried through the gas piping into the gas valve inlet after installation, may cause the gas valve to malfunction and could result in possible improper heating, explosion, fire or asphyxiation. Also, pipe sealant must be resistant to Propane gas.

A main shut-off valve shall be installed externally of furnace casing. After piping has been installed, turn gas on and check all connections with a leak detector or soap solution.

Never use open flame to test for gas leaks as fire or explosion could occur.

Do not test the fuel system at more than 14" W.C. after furnace has been connected to fuel line. Such testing could void the warranty. Any test run above 14" W.C. may damage furnace control valve which could cause an explosion, fire or asphyxiation.

A drip leg is required by some local codes to trap moisture and contaminations. Refer to Figure 39 or 40.

For natural gas operation, the furnace is designed for 7" W.C. inlet gas pressure. Pressure to main burner is then reduced to 3 1/2" W.C at the gas valve.

Refer to Figure 42 for location of Gas Valve Main Regulator Adjustment.

The furnace must be isolated from the gas supply piping system by closing its individual external manual shut-off valve during any pressure testing of the gas supply piping system at pressures equal to or less than 1/2 psig (3.5 kPa).

Gas piping may be connected from either side of the furnace using any of the gas pipe entry knockouts on both sides of the furnace. Refer to Figure 39 Gas Piping.

GAS ORIFICE CONVERSION FOR PROPANE (LP)

This burner is constructed at the factory for natural gas-fired operation, but may be converted to operate on propane (LP) gas by using a factory-supplied LP conversion kit. Follow the instructions supplied with the LP kit. Refer to Table 18 or the instructions in the propane (LP) conversion kit for the proper gas orifice size.

IMPORTANT: When converting gas valve from or to Propane gas, it will be necessary to change main burner orifice to prevent an underfired or overfired condition. Refer to furnace rating plate or to Table 18 for proper orifice size.

DANGER

The manifold pressure does not change when converting to Natural or Propane Gas. The manifold pressure is 3.5 in w.c. (0.87 kPa) on both Natural and Propane Gas. Change only the gas orifice when converting this burner to Natural or Propane Gas. Manifold pressure in excess of 4.0 in w.c (0.99 kPa) can cause premature heat exchanger failure. High levels of carbon monoxide, excessive soot-ing, a fire hazard, personal injury, property damage, and/or death.

HIGH ALTITUDE GAS ORIFICE CONVERSION

This furnace is constructed at the factory for natural gas-fired operation at 0 – 2,000 ft. (0 m – 610 m) above sea level.

The gas orifices on this furnace must be changed in order to maintain proper and safe operation, when the furnace is installed in a location where the altitude is greater than 2,000 ft. (610 m) above sea level on natural gas or the altitude is greater than 4,000 ft. (1219 m) above sea level on propane (LP) gas. Refer to Table 18 or the instructions in the high altitude conversion kit for the proper gas orifice size.

For Propane gas operation, the furnace is designed for 11" w.c. (2.74 kPa) inlet gas pressure. Pressure to main burner is then reduced to 3.5" w.c. (0.87 kPa).

The unit may also be converted for altitudes up to 10,000 ft. (3048 m) on natural and propane (LP) gas with additional derate as shown in Table 18 or refer to ANSI Z223.1 NFPA 54 National Fuel Gas Code or in Canada CAN/CGA-B149.1-00 Natural Gas and Propane Installation Code.

HIGH ALTITUDE PRESSURE SWITCH CONVERSION

For installation in locations where the altitude is less than 4,500 feet (1372 m), it is not required that the pressure switch be changed. For altitudes above 4,500 feet (137 m), refer to Instructions in the Accessory High Altitude Kit.

DANGER**PROPANE AND HIGH ALTITUDE CONVERSION KITS**

It is very important to choose the correct kit and/or gas orifices for the altitude and the type of gas for which the furnace is being installed.

Only use natural gas in furnaces designed for natural gas. Only use propane (LP) gas for furnaces that have been properly converted to use propane (LP) gas. Do not use this furnace with butane gas.

Incorrect gas orifices or a furnace that has been improperly converted will create an extremely dangerous condition resulting in premature heat exchanger failure, excessive sooting, high levels of carbon monoxide, personal injury, property damage, a fire hazard and/or death.

High altitude and propane (LP) conversions are required in order for the appliance to satisfactorily meet the application.

An authorized distributor or dealer must make all gas conversions.

In Canada, a certified conversion station or other qualified agency, using factory specified and/or approved parts, must perform the conversion.

The installer must take every precaution to insure that the furnace has been converted to the proper gas orifice size when the furnace is installed. Do not attempt to drill out any orifices to obtain the proper orifice size. Drilling out a gas orifice will cause misalignment of the burner flames, causing premature heat exchanger burnout, high levels of carbon monoxide, excessive sooting, a fire hazard, personal injury, property damage and/or death.

TABLE 18: High Altitude Duration Chart

NATURAL GAS													
Elevation Feet	56,000 — Input				70,000 — Input			77,000 — Input			90,000 — Input		
	Meters	Orifice Dia.	Drill Size	Part #	Orifice Dia.	Drill Size	Part #	Orifice Dia.	Drill Size	Part #	Orifice Dia.	Drill Size	Part #
Sea Level		0.136	29	9951--1361	0.154	23	9951--1541	0.161	20	9951--1611	0.180	15	9951--1801
2,000	618	0.136	29	9951--1361	0.149	25	9951--1491	0.157	22	9951--1571	0.177	16	9951--1771
3,000	914	0.128	30	9951--1281	0.149	25	9951--1491	0.157	22	9951--1571	0.173	17	9951--1731
4,000	1219	0.128	30	9951--1281	0.147	26	9951--1471	0.154	23	9951--1541	0.173	17	9951--1731
5,000	1524	0.128	30	9951--1281	0.144	27	9951--1441	0.152	24	9951--1521	0.169	18	9951--1691
6,000	1829	0.128	30	9951--1281	0.144	27	9951--1441	0.149	25	9951--1491	0.166	19	9951--1661
7,000	2134	0.120	31	9951--1201	0.140	28	9951--1401	0.147	26	9951--1471	0.161	20	9951--1611
8,000	2438	0.120	31	9951--1201	0.136	29	9951--1361	0.144	27	9951--1441	0.161	20	9951--1611
9,000	2743	0.120	31	9951--1201	0.136	29	9951--1361	0.140	28	9951--1401	0.157	22	9951--1571
10,000	3048	0.116	32	9951--1161	0.128	30	9951--1281	0.136	29	9951--1361	0.152	24	9951--1521

PROPANE GAS													
Elevation Feet	56,000 — Input				70,000 — Input			77,000 — Input			90,000 — Input		
	Meters	Orifice Dia.	Drill Size	Part #	Orifice Dia.	Drill Size	Part #	Orifice Dia.	Drill Size	Part #	Orifice Dia.	Drill Size	Part #
Sea Level		0.082	45	9951--0821	0.093	42	9951--0931	0.098	40	9951--0981	0.106	36	9951--1061
2,000	618	0.081	46	9951--0811	0.093	42	9951--0931	0.096	41	9951--0961	0.104	37	9951--1041
3,000	914	0.078	47	9951--0781	0.089	43	9951--0891	0.093	42	9951--0931	0.101	38	9951--1011
4,000	1219	0.078	47	9951--0781	0.089	43	9951--0891	0.093	42	9951--0931	0.101	38	9951--1011
5,000	1524	0.078	47	9951--0781	0.089	43	9951--0891	0.093	42	9951--0931	0.099	39	9951--0991
6,000	1829	0.076	48	9951--0761	0.086	44	9951--0861	0.089	43	9951--0891	0.098	40	9951--0981
7,000	2134	0.076	48	9951--0761	0.086	44	9951--0861	0.089	43	9951--0891	0.096	41	9951--0961
8,000	2438	0.073	49	9951--0731	0.082	45	9951--0821	0.086	44	9951--0861	0.096	41	9951--0961
9,000	2743	0.073	49	9951--0731	0.081	46	9951--0811	0.086	44	9951--0861	0.093	42	9951--0931
10,000	3048	0.070	50	9951--0731	0.078	47	9951--0781	0.082	45	9951--0821	0.089	43	9951--0891

Table shows 4% Input Reduction per 1,000 ft. (304.8 m) Elevation. Reference Source: NFPA No. 54, ANSI Z 223.1, National Fuel Gas Code.
For Canadian high altitude (2000 - 4500 ft. (609.6 - 1,371.6)), reduce gas manifold pressure to 3.0" w.c. (0.75 kPa) for Natural gas and for Propane gas.

SIZING FURNACE INPUT

The orifice spud supplied with all burners is the size for the minimum BTU input of the burner for the type gas shown on the rating plate. Table 18 shows the correct drill size for various inputs.

The correct manifold pressure for natural and LP gas is 3.5" w.c (0.87 kPa). Only minor adjustments in the input rate should be made by adjusting the pressure regulator. The minimum manifold pressure should be 3.0" w.c. (0.75 kPa) and the maximum pressure should be 3.5 w.c. (0.87 kPa) the next size larger or smaller orifice size should be used if the desired input rating cannot be obtained within the above manifold pressure adjustment range.

TABLE 19: Gas Burner Settings

Gas (@ 3.5" W.C.)	Firing Rate BTU/Hr (kw)	Orifice Size	Air Shutter Setting
Natural	66,000 (19.3)	0.142" (3.61mm)	1.0
Natural	84,000 (24.6)	0.166" (4.22 mm)	3.5
LP	66,000 (19.3)	0.116" (2.95 mm)	2.0
LP	84,000 (24.6)	0.100" (2.54 mm)	3.5

NOTE: The BTU input valves in the above table show the approximate hourly input of the burner for the various drill sizes shown. To determine the actual input of the burner, turn off all other gas appliances.

▲ WARNING

CARBON MONOXIDE POISONING HAZARD

Failure to follow the steps outlined below for each appliance connected to the venting system being placed into operation could result in carbon monoxide poisoning or death.

The following steps shall be followed for each appliance connected to the venting system being placed into operation, while all other appliances connected to the venting system are not in operation:

1. Inspect the venting system for proper size and horizontal pitch. Determine that there is no blockage, restriction, leakage, corrosion or other deficiencies, which could cause an unsafe condition
2. Close all building doors and windows and all doors.
3. Turn on clothes dryers and TURN ON any exhaust fans, such as range hoods and bathroom exhausts, so they shall operate at maximum speed. Open the fireplace dampers. Do not operate a summer exhaust fan.
4. Follow the lighting instructions. Place the appliance being inspected in operation. Adjust thermostat so the appliance shall operate continuously.
5. Test each appliance (such as a water heater) equipped with a draft hood for spillage (down-draft or no draft) at the draft hood relief opening after 5 minutes of main burner operation. Appliances that do not have draft hoods need to be checked at the vent pipe as close to the appliance as possible. Use a combustion analyzer to check the CO₂ and CO levels of each appliance. Use a draft gauge to check for a downdraft or inadequate draft condition.
6. After it has been determined that each appliance properly vents when tested as outlined above, return doors, windows, exhaust fans, fireplace dampers and any other gas burning appliance to their normal condition.
7. If improper venting is observed during any of the above tests, a problem exists with either the venting system or the appliance does not have enough combustion air (Supply Air from outside) to complete combustion. This condition must be corrected before the appliance can function safely.

NOTE: An unsafe condition exists when the CO reading at the furnace vent exceeds 40 ppm and the draft reading is not in excess of - 0.1 in. W.C. (-0.025 kPa) with all of the appliance(s) operating at the same time.

8. Any corrections to the venting system and / or to the supply (outside) air system must be in accordance with the National Fuel Gas Code Z223.1 or CAN/CGA B149.1-00 Natural Gas and Propane Installation Code (latest editions). If the vent system must be resized, follow the appropriate tables in Appendix G of the above codes or for this appliance.

SECTION XI: START-UP AND ADJUSTMENTS

The initial start-up of the furnace requires the following additional procedures:

IMPORTANT: All electrical connections made in the field and in the factory should be checked for proper tightness.

When the gas supply is initially connected to the furnace, the gas piping may be full of air. In order to purge this air, it is recommended that the ground union be loosened until the odor of gas is detected. When gas is detected, immediately retighten the union and check for leaks. Allow five minutes for any gas to dissipate before continuing with the start-up procedure. Be sure proper ventilation is available to dilute and carry away any vented gas.

PURGING

After the piping has been checked, all piping and appliances receiving gas through the meter shall be fully purged. A suggested method for purging the gas line to the burner is to allow the burner to cycle until burner ignites. Do not purge by loosening gas lines. Under no circumstances shall the line be purged into the combustion chamber.

After the gas line to the conversion burner has been fully purged, the gas supply at other pilot burners located on other gas appliances which were extinguished as the result of interrupted service will need to be reignited. Check all appliances to make sure the pilots are ignited.

CALCULATING THE FURNACE INPUT (NATURAL GAS)

NOTE: Front door of burner box must be secured when checking gas input.

NOTE: Burner orifices are sized to provide proper input rate using natural gas with a heating value of 1030 BTU/Ft³ (3.6 mj/m³). If the heating value of your gas is significantly different, it may be necessary to replace the orifices.

1. Turn off all other gas appliances connected to the gas meter.
2. At the gas meter, measure the time (with a stop watch) it takes to use 2 cubic ft. (0.0566 m³) of gas.
3. Calculate the furnace input by using one of the following equations.

In the USA use the following formula to calculate the furnace input.

For natural gas multiply the heat content of the gas BTU/SCF or Default 1030 BTU/SCF (38.4 MJ/m³), times 2 cubic ft. (0.056 m) of gas measured at the gas meter, times a barometric pressure and temperature correction factor of 0.960; times 3600, then divided by the time (In seconds) it took to measure 2 cubic ft. (0.056 m) of gas from the gas meter.

For propane (LP) gas multiply the heat content of the gas BTU/SCF or Default 2500 BTU/SCF (93.15 MJ/m³), times 1 cubic ft. (0.028 m) of gas measured at the gas meter, times a barometric pressure and temperature correction factor of 0.960; times 3600, then divided by the time (In seconds) it took to measure 1 cubic ft. (0.028 m) of gas from the gas meter.

The formula for US input calculation using a cubic foot gas meter:

$\frac{\text{BTU/ft}^3 \times 2 \text{ cu.ft.} \times 0.960 \times 3600}{\text{Seconds it took to measure the 2 cu.ft. of gas}}$ = BTU/H	$\frac{\text{BTU/ft}^3 \times 1 \text{ cu.ft.} \times 0.960 \times 3600}{\text{Seconds it took to measure the 1 cu.ft. of gas}}$ = BTU/H
NATURAL GAS INPUT CALCULATION	PROPANE (LP) GAS INPUT CALCULATION
EXAMPLE: $\frac{1030 \times 2 \times 0.960 \times 3600}{90.5}$ = 78,666.90	EXAMPLE: $\frac{2500 \times 1 \times 0.960 \times 3600}{108}$ = 80,000.00
Natural Gas 1030 BTU/SCF	Propane Gas 2500 BTU/SCF

In Canada you will use the following formula to calculate the furnace input if you are using a cubic foot gas meter.

For Natural Gas multiply the Heat content of the gas MJ/m³ (or Default 38.4), times 2 cubic ft. of gas x 0.028 to convert from cubic feet to cubic meters measured at the gas meter, times a barometric pressure and temperature correction factor of 0.960; times 3600, then divided by the time it took to measure 2 cubic ft. (0.056 m) of gas from the gas meter.

For Propane (LP) Gas multiply the Heat content of the gas MJ/m³ (or Default 93.15), times 1 cu. ft. of gas x 0.028 to convert from cubic feet to cubic meters measured at the gas meter, times a barometric pressure and temperature correction factor of 0.960; times 3600, then divided by the time it took to measure 1 cubic ft. (0.028 m) of gas from the gas meter.

The formula for metric input calculation using a cubic foot gas meter:

$\frac{\text{MJ/m}^3 \times 2 \text{ cu.ft.} \times 0.028 \times 0.960 \times 3600}{\text{Seconds it took to measure the 2 cu.ft. of gas}}$ = MJ/H x 0.2777 = kW x 3412.14 = BTU/H
NATURAL GAS INPUT CALCULATION
EXAMPLE: $\frac{38.4 \times 2 \times 0.028 \times 0.960 \times 3600}{90.5}$ = 82.12 x 0.2777 = 22.80 x 3412.14 = 77,796.80
Natural Gas 1030 BTU/SCF = 38.4 MJ/m ³
PROPANE (LP) GAS INPUT CALCULATION
EXAMPLE: $\frac{93.15 \times 1 \times 0.028 \times 0.960 \times 3600}{108}$ = 83.46 x 0.2777 = 23.18 x 3412.14 = 79,093.4
Propane Gas 2500 BTU/SCF = 93.15 MJ/m ³

In Canada use the following formula to calculate the furnace input if you are using a gas meter that measures cubic meters.

For Natural Gas multiply the Heat content of the gas MJ/m³ (or Default 38.4), times 0.10 m³ of gas measured at the gas meter, times a barometric pressure and temperature correction factor of 0.960; times 3600, then divided by the time it took to measure 0.10 m³ of gas from the gas meter.

For Propane (LP) Gas multiply the Heat content of the gas MJ/m³ (or Default 93.15), times 0.10 m³ of gas measured at the gas meter, times a barometric pressure and temperature correction factor of 0.960; times 3600, then divided by the time it took to measure 0.10 m³ of gas from the gas meter.

The formula for metric input calculation using a cubic meter gas meter:

$\frac{\text{MJ/m}^3 \times \text{m}^3 \times 0.960 \times 3600}{\text{Seconds it took to measure the 0.10 m}^3 \text{ of gas}}$ = MJ/H x 0.2777 = kW x 3412.14 = BTU/H
NATURAL GAS INPUT CALCULATION
EXAMPLE: $\frac{38.4 \times 0.1 \times 0.960 \times 3600}{160}$ = 82.94 x 0.2777 = 23.03 x 3412.14 = 78,581.60
Natural Gas 1030 BTU/SCF = 38.4 MJ/m ³
PROPANE (LP) GAS INPUT CALCULATION
EXAMPLE: $\frac{93.15 \times 0.1 \times 0.960 \times 3600}{387}$ = 83.19 x 0.2777 = 23.10 x 3412.14 = 78,826.3
Propane Gas 2500 BTU/SCF = 93.15 MJ/m ³

DO NOT ADJUST the manifold pressure regulator if the actual input is equal to or within 8% less than the furnace input specified on the rating plate or if the furnace rise is above the specified rise range on the rating plate.

If the actual input is significantly higher than the furnace input specified on the rating plate then replace the gas orifices with the gas orifices of the proper size for the type of gas you are using.

For altitudes above 2,000 ft. (610 m) the furnace input MUST BE DERATED. Refer to the GAS CONVERSION FOR PROPANE (LP) AND HIGH ALTITUDES IN SECTION IV for information on high altitude conversions.

INITIAL START UP

1. Read the applicable sequence of gas control operation in the Operation and Troubleshooting section before proceeding.
2. Move the gas valve control switch to the "OFF" position.
3. Adjust the primary air. Set the damper to the start up settings.
4. On new gas line installations, air may be trapped in the line, the burner may experience several lockouts until all the air is purged from the lines.
5. Turn on the main electrical power and set the thermostat to call for heat. Allow the burner to run a MINIMUM of 5 minutes to purge combustion chamber and appliance heat exchanger.
6. Set the thermostat below room temperature, shutting the burner "OFF".
7. Move the gas valve control switch to the "ON" position.
8. Set the thermostat or operating control to call for heat. The burner will start and go through the applicable sequence of burner/primary gas control operation, refer to step 1.
9. Once burner is running, adjust the orifice manifold pressure regulator as described in Pressure Regulator Adjustment.

CAUTION

Be sure to relight any gas appliances that were turned off at the start of this input check.

CHECKING THE GAS PRESSURES

1. The pressure ports on the gas valve are marked OUT and INLET.
2. The manifold pressure must be taken at the port marked OUT.
3. The inlet gas supply pressure must be taken at the port marked INLET.
4. Using a 3/32" (0.2 cm) Allen wrench, loosen the set screw by turning it 1 turn counter clockwise. DO NOT REMOVE THE SET SCREW FROM THE PRESSURE PORT.
5. Use the 4" (10.2 cm) piece of 3/8" (0.9 cm) tubing to connect the positive side of the manometer to the gas valve pressure reference port. Refer to Figure 43 for connection details.

TABLE 20: Inlet Gas Pressure Range

INLET GAS PRESSURE RANGE		
	Natural Gas	Propane (LP)
Minimum	4.5" W.C. (1.12 kPa)	8.0" W.C. (1.99 kPa)
Maximum	10.5" W.C. (2.61 kPa)	13.0" (3.24 kPa) W.C.

IMPORTANT: The inlet gas pressure operating range table specifies the minimum and maximum gas line pressures required for safe furnace operation.

The minimum inlet gas pressure required to obtain the BTU input specified on the rating plate and in these instructions is shown below:

- 7.0" w.c. (1.74 kPa) for Natural Gas
- 11.0" w.c. (2.74 kPa) for Propane (LP) Gas

ADJUSTMENT OF MANIFOLD GAS PRESSURE

Manifold gas pressure may be measured at the gas valve.

Turn gas off at the ball valve or gas cock on gas supply line before the gas valve. Find the pressure ports on the gas valve marked OUT and INLET.

IMPORTANT: The cap for the pressure regulator must be removed entirely to gain access to the adjustment screw. Loosening or tightening the cap does not adjust the flow of gas.

1. Refer to Figure 42 for location of pressure regulator adjustment cap and adjustment screw on main gas valve.
2. Adjust manifold pressure by adjusting gas valve regulator screw for the appropriate gas per the following:

TABLE 21: Nominal Manifold Pressure

NOMINAL MANIFOLD PRESSURE	
Natural Gas	3.5" w.c. (0.87 kPa)
Propane (LP) Gas	3.5" w.c. (0.87 kPa)

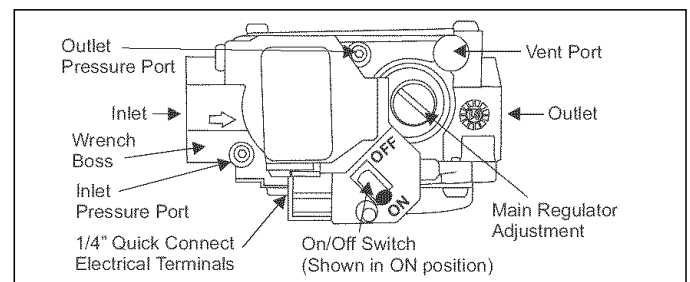

FIGURE 42: Gas Valve

IMPORTANT: If gas valve regulator is turned in (clockwise), manifold pressure is increased. If screw is turned out (counter clockwise), manifold pressure will decrease.

3. After the manifold pressure has been adjusted, re-calculate the furnace input to make sure you have not exceeded the specified input on the rating plate. Refer to "CALCULATING THE FURNACE INPUT (NATURAL GAS)".
4. Once the correct BTU (kW) input has been established, turn the gas valve to OFF and turn the electrical supply switch to OFF; then remove the flexible tubing and fittings from the gas valve pressure tap and tighten the pressure tap plug using the 3/32" Allen wrench.
5. Turn the electrical and gas supplies back on, and with the burners in operation, check for gas leakage around the gas valve pressure port for leakage using an approved gas detector, a non-corrosive leak detection fluid, or other leak detection methods.

WARNING

The manifold pressure must be checked with the screw-off cap for the gas valve pressure regulator in place. If not, the manifold pressure setting could result in an over-fire condition. A high manifold pressure will cause an over-fire condition, which could cause premature heat exchanger failure. If the manifold pressure is too low, sooting and eventual clogging of the heat exchanger could occur. Be sure that gas valve regulator cap is in place.

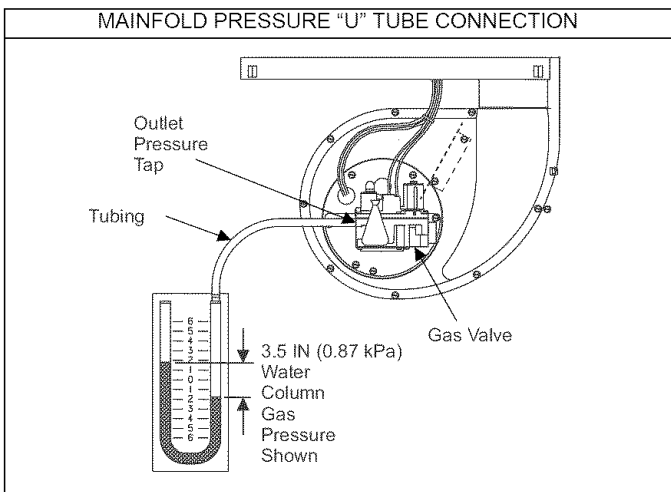

FIGURE 43: Reading Gas Pressure

Observing Burner Operation

1. Observe burner to make sure it ignites. Observe color of flame. On natural gas the flame will burn blue with appreciably yellow tips. On Propane gas a yellow flame may be expected. If flame is not the proper color call a qualified service technician for service.
2. Let furnace heat until blower cycles on.
3. Turn thermostat down.
4. Observe burner to make sure it shuts off.
5. Let the furnace cool and blower cycle off.

WARNING

Should overheating occur, or the gas supply fail to shut off, shut off the manual gas valve to the furnace and allow burner to run until furnace cools down and blower shuts off before shutting off the electrical supply.

If any abnormalities are observed when checking for correct operation, such as burner failing to ignite or to turn off, sooty flame, etc., call your nearest authorized service technician as shown in the Service Center List included in the home owner envelope with the furnace.

If Furnace Fails to Operate Properly

1. Check setting of thermostat - and position of HEAT/COOL switch if air conditioning is installed. If a set-back type thermostat is employed be sure that the thermostat is in the correct operating mode.
2. Check to see that electrical power is ON.
3. Check to see that the switch on the gas control valve is in the full ON position.
4. Make sure filters are clean, return grilles are not obstructed, and supply registers are open.
5. Be sure that furnace flue piping is open and unobstructed.

If the cause for the failure to operate is not obvious, do not attempt to service the furnace yourself. Call a qualified service agency or your gas supplier.

ADJUSTMENT OF TEMPERATURE RISE

⚠ DANGER

The temperature rise, or temperature difference between the return air and the supply (heated) air from the furnace, must be within the range shown on the furnace rating plate and within the application limitations shown in Table 8 "ELECTRICAL AND PERFORMANCE DATA".

The supply air temperature cannot exceed the "Maximum Supply Air Temperature" specified in these instructions and on the furnace rating plate. Under NO circumstances can the furnace be allowed to operate above the Maximum Supply Air Temperature. Operating the furnace above the Maximum Supply Air Temperature will cause premature heat exchanger failure, high levels of Carbon Monoxide, a fire hazard, personal injury, property damage, and/or death.

The temperature rise, or temperature difference between the return air and the heated supply air from the furnace, must be within the range shown on the furnace rating plate and within the application limitations as shown in Table 8.

After about 20 minutes of operation, determine the furnace temperature rise. Take readings of both the return air and the heated air in the ducts. Increase the blower speed to decrease the temperature rise; decrease the blower speed to increase the rise.

⚠ CAUTION

Do not energize more than one motor speed at a time or damage to the motor will result.

PERFORMANCE CHECK

1. After the desired input has been obtained, re-adjust the primary air damper open or closed to visually obtain a blue flame with well defined orange or yellow tips for natural gas, or well defined yellow tips for propane gas.
2. After the burner has been in operation for at least 20 minutes, assuring combustion chamber and heat exchanger are fully warmed, take combustion analysis flue gas samples in the flue pipe.

All adjustments below must be made with the following instructions:

- a. Draft Gauge
- b. O₂ or CO₂ Analyzer
- c. CO Tester
- d. Water Column Gauge

NOTE: ALWAYS USE RELIABLE COMBUSTION TEST INSTRUMENTS. BEING PROFICIENT IN THE USE OF THESE INSTRUMENTS AND INTERPRETING THE DATA IS NECESSARY FOR SAFE, RELIABLE AND EFFICIENT BURNER OPERATION.

IT IS ESSENTIAL TO MAKE CERTAIN THAT THE PRODUCTS OF COMBUSTION DO NOT CONTAIN CARBON MONOXIDE, CO.

The most common causes of CO are flame impingement on cool surface and insufficient primary air, both of which could be caused by over firing. The only answer is to reduce the firing rate or increase the primary air.

Combustion efficiency is determined by the percent CO₂ and the temperature of the flue gases. These two measurements are taken on the vent. Combustion efficiency and stack loss calculators are available from several manufacturers of combustion test equipment.

IMPORTANT: DRAFT - When installing Wayne power conversion gas burners in oil fired furnaces a minimum negative draft of .01" w.c. (0.0025 kPa) over fire must be maintained.

Refer to your local gas company and codes for assistance.

3. Perform the following combustion analysis. All adjustments below must be made with the following instruments: draft gauge, O₂ or CO₂ analyzer and CO tester.
 - a. Adjust the primary air damper to provide about 25% excess combustion air. Confirm this by checking the flue gas for its FREE OXYGEN (O₂) or CARBON DIOXIDE (CO₂) PERCENTAGES with a test instrument. Free oxygen should be about 4.5%, or carbon dioxide should be about 9.5% for natural gas, 12.1% for propane gas.
 - b. CARBON MONOXIDE - Should be checked for its presence in the flue gas. This percentage should not exceed .04% (or 400 PPM).

NOTE: Check overfire draft and adjust to NEGATIVE -.01 (0.0025 kPa) to -.02 (4.982 pa) inches w.c. during burner operation.

OPERATION AND TROUBLESHOOTING

SEQUENCE OF OPERATION — SC80-C GAS BURNER UTILIZING HONEYWELL S87K GAS PRIMARY WITH BUILT IN 30 SECOND PREPURGE

On a call for heat, voltage (24V) is applied to motor start relay and air switch. Once the fan motor reaches operating rpm, combustion air pressure is sensed by the air proving switch and closes the switch contacts energizing the S89F gas primary control.

The S87K gas primary control has an internal 30 second prepurge timer. After the initial 30 second prepurge, an internal 8 second safe start check of the S89F will commence. Once this is successfully completed, the S87K simultaneously energizes the gas valve and ignition transformer. Gas flows and the transformer produces an approximate 7300 volt spark end point grounded at the burner head establishing main burner flame.

At the start of each heat cycle, there is a trial for an ignition period of a four (4) second duration. Normally, burner flame will be established before the end of this period. Once the flame is established, sparking will cease and the flame rod will provide flame monitoring to the S87K gas control primary for the remainder of the heat cycle. If the flame should be extinguished during the heat cycle, the S87K gas control primary will go into the 30 second prepurge and 8 second safe start check, then re-energize the gas valve and ignition transformer in an attempt to establish the main burner flame. If this does not occur within the 4 second trial for ignition period, the S87K gas primary control will go into lockout de-energizing the gas valve and ignition transformer.

To restart the system, the main power or thermostat must be de-energized momentarily, then re-energized. If, at any time during the heat cycle, there is an insufficient supply of combustion air to the burner, the air switch will open, putting the system into lockout, closing the gas valve.

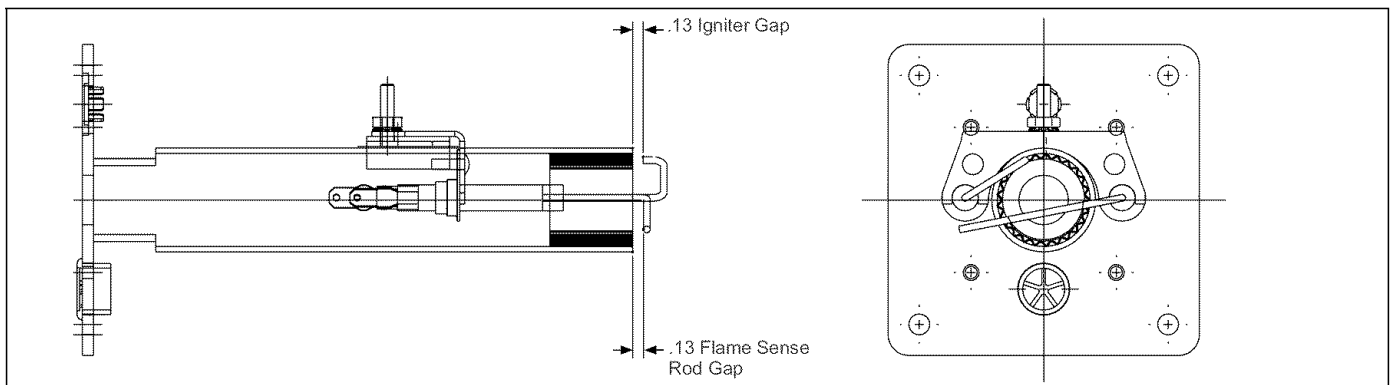

FIGURE 44: Electrode Orientation and Gap

FIGURE 45: Wiring Diagram for DFCA - Gas Conversion Burner

BLOWER SPEED CHART
(CHARTRE DE VITESSE DE LA SOUFFLERIE)

INPUT (ENTREE)	CFM (PCM)	HEAT/COOL (CHAU/CLIMA)
066	1050	BLK (NOIR)
084	1245	BLK (NOIR)

WIRE COLOR KEY
(CODE DE COULEUR DU FILAGE)

BLK (NOIR)	BLACK (NOIR)
BLU (BLEU)	BLUE (BLEU)
RED (ROUGE)	RED (ROUGE)
YEL (JAUNE)	YELLOW (JAUNE)
WHT (BLANC)	WHITE (BLANC)
BRN (BRUN)	BROWN (BRUN)
GRN (VERT)	GREEN (VERT)
PRP (POURPRE)	PURPLE (POURPRE)
GRY (ORANGE)	ORANGE (ORANGE)

- CAUTION -
OPEN ALL DISCONNECTS BEFORE SERVICING THIS UNIT

- PRECAUTION -
OUVREZ LES DISJONCTEURS AVANT DE PROCÉDER AVEC LE SERVICE

80+ DOWNFLOW FURNACE
(FOURNAISE 80+ VENTILÉE PAR LE HAUT)

NOTES:

- TOUT FILAGE EN CHANTIER SELON: (A) CODE ELEC. NATIONAL (CEN) ET/OU/ (B) CODE ELEC. CANADIEN (CC) ET/OU/ (C) CODES LOCAUX ET MUNICIPAUX.
- SI LE FILAGE DOIT ÊTRE REMPLACÉ EN PÂTRIE OU EN TOUT, IL DOIT L'ÊTRE AVEC UN MATÉRIEL POUVANT RESISTER A DES TEMPÉRATURES D'AU MOINS 221°F (105°C).
- SEULEMENT DES MARETTES POUR FIL DE CUIVRE.
- TOUË COMPOSANTE DE REMPLACEMENT DOIT ÊTRE BIEN MISE EN TERRE.
- FOURNISSEZ LES DISJONCTEURS POUR L'ALIMENTATION.
- LES MOTEURS SONT PROTÉGÉS DE PAR LEUR CONCEPTION.

LEGEND

- BM BURNER MOTOR
- PC PRIMARY CONTROL
- IT IGNITION TRANSFORMER
- RZ RELAY
- PC PRIMARY CONTROL
- P1/S1 9 PIN PLUG & SOCKET ON BLOWER MOTOR
- LS1 PRIMARY LIMIT SWITCH
- LS2 LIMIT SWITCH
- CS CENTRIFUGAL SWITCH
- IRC RUN CAPACITOR
- IT TRANSFORMER
- ⊗ IDENTIFIED RUN CAPACITOR
- △ 24V CONNECTION FROM THERMOSTAT
- FIELD CONNECTION
- FACTORY WIRING AND DEVICES
- FIELD WIRING AND DEVICES

LADDER DIAGRAM
(DIAGRAMME ÉLÉMENTAIRE)

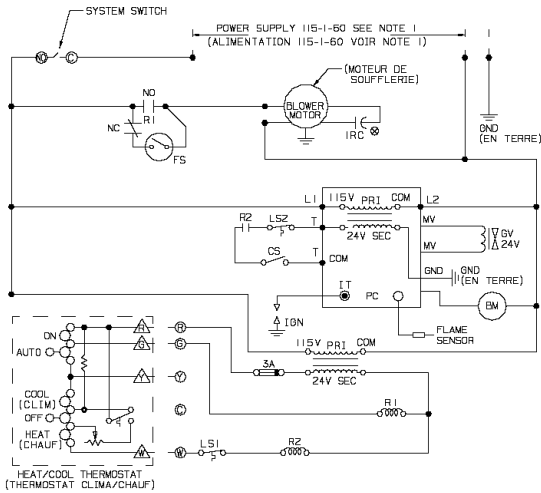

NOTES:

- ALL FIELD WIRING PER: (A) NATIONAL ELEC. CODE (NEC) AND/OR/ (B) CANADIAN ELEC. CODE (CEC) AND/OR/ (C) LOCAL OR CITY CODES.
- IF ANY OF THE ORIGINAL WIRE AS SUPPLIED WITH THE FURNACE MUST BE REPLACED, IT MUST BE REPLACED WITH WIRING MATERIAL HAVING A TEMPERATURE RATING OF AT LEAST 221°F (105°C).
- CONNECTORS SUITABLE FOR COPPER CONDUCTORS ONLY.
- ALL REPLACEMENT COMPONENTS MUST BE PROPERLY GROUNDED.
- PROVIDE DISCONNECTS FOR ALL POWER SUPPLIES.
- MOTORS ARE INHERENTLY PROTECTED.

LEGENDE

- BM MOTEUR DU BRÛLEUR
- PC CONTRÔLE PRIMAIRE
- IT TRANSFORMATEUR D'IGNITION
- RZ RELAIS
- PC CONTRÔLE PRIMAIRE
- P1/S1 LE MOTEUR DE LA SOUFFLERIE DOUILLE ET BOUCHON A 9 PIGES SUR
- LS1 COMMUTATEUR DE LIMITE PRINCIPALE
- LS2 COMMUTATEUR DE LIMITE
- CS COMMUTATEUR CENTRIFIQUE
- IRC CAPACITEUR DE FONCTIONNEMENT IDENTIFIE
- IT TRANSFORMEUR
- ⊗ CAPACITEUR DE FONCTIONNEMENT IDENTIFIE
- △ 24V RACCORDEMENT DU THERMOSTAT DE PIECE
- RACCORDEMENT DE CHANTIER
- FILAGE DE L'USINE ET APPAREILS
- FILAGE DE CHANTIER ET APPAREILS

IF ANY OF THE ORIGINAL WIRE SUPPLIED WITH THIS UNIT MUST BE REPLACED, IT MUST BE REPLACED WITH TYPE 105°C THERMOPLASTIC OR ITS EQUIVALENT.

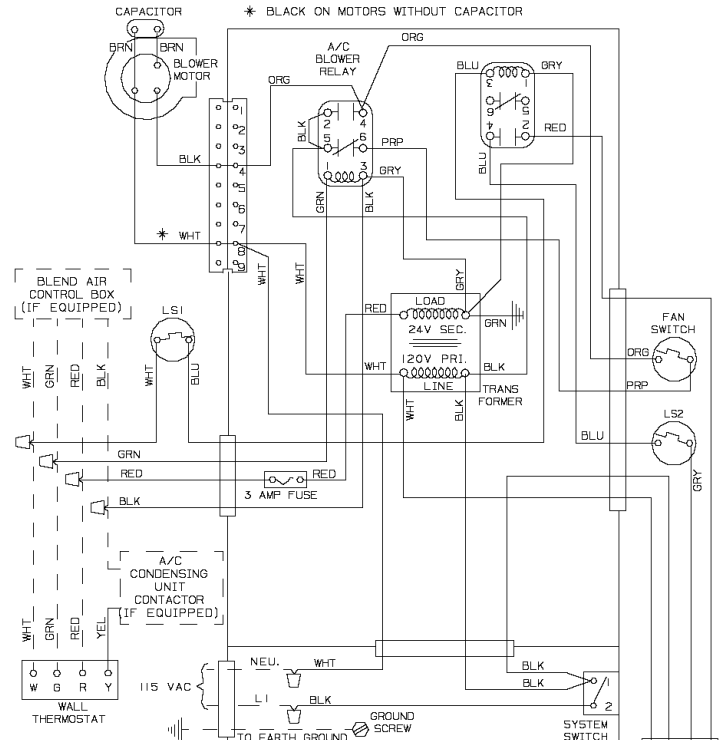

INCOMING POWER MUST BE POLARIZED, OBSERVE COLOR CODING.
L'ALIMENTATION DU COURANT DOIT ÊTRE POLARISÉE, SUIVEZ LES CODES DE COULEURS.

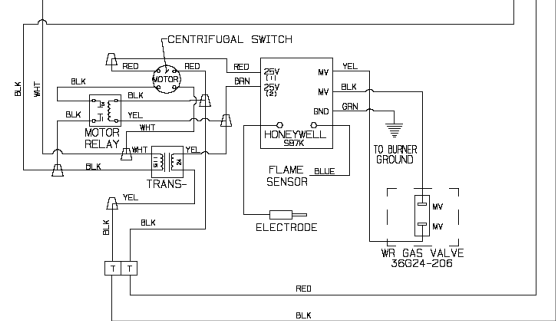

107467-UWD-A-0705

FIGURE 46: Wiring Diagram for DFAH - Gas Gun

**BLOWER SPEED CHART
(CHARTRE DE VITESSE
DE LA SOUFFLERIE)**

INPUT (ENTREE)	CFM (PCM)	HEAT/COOL (CHAU/CLIMA)
066	1050	BLK (NOIR)
084	1245	BLK (NOIR)

**WIRE COLOR KEY
(CODE DE COULEUR
DU FILAGE)**

BLK (NOIR)	BLACK (NOIR)
BLU (BLEU)	BLUE (BLEU)
RED (ROUGE)	RED (ROUGE)
YEL (JAUN)	YELLOW (JAUNE)
WHT (BLANC)	WHITE (BLANC)
BRN (BRUN)	BROWN (BRUN)
GRN (VERT)	GREEN (VERT)
PRP (POURPRE)	PURPLE (POURPRE)
ORN (ORANGE)	ORANGE (ORANGE)

- CAUTION -
OPEN ALL DISCONNECTS BEFORE
SERVICING THIS UNIT

- PRÉCAUTION -
OUVREZ LES DISJONCTEURS AVANT
DE PROCÉDER AVEC LE SERVICE

80+ DOWNFLOW FURNACE

**(FOURNAISE 80+
VENTILÉE PAR LE HAUT)**

NOTES:

1. TOUT FILAGE EN CHANTIER SELON: (A) CODE ELEC. NATIONAL (CEN) ET/OU/ (B) CODE ELEC CANADIEN (CEC) ET/OU/ (C) CODES LOCAUX ET MUNICIPAUX.
2. SI LE FILAGE DOIT ÊTRE REMPLACÉ EN PATRIE OU EN TOUT, IL DOIT L'ÊTRE AVEC UN MATÉRIEL POUVANT RESISTER A DES TEMPERATURES D'AU MOINS 221°F (105°C).
3. SEULEMENT DES MARETTES POUR FIL DE CUIVRE.
4. TOUTE COMPOSANTE DE REMPLACEMENT DOIT ÊTRE BIEN MISE EN TERRE.
5. FOURNISSEZ LES DISJONCTEURS POUR L'ALIMENTATION.
6. LES MOTEURS SONT PROTÉGÉS DE PAR LEUR CONCEPTION.

LEGEND

- BM BURNER MOTOR
- PC PRIMARY CONTROL
- IT IGNITION TRANSFORMER
- RI RELAY
- SV SOLENOID VALVE
- PC PRIMARY CONTROL
- P1/S1 9 PIN PLUG & SOCKET ON BLOWER MOTOR
- LS1 PRIMARY LIMIT SWITCH
- LS2 LIMIT SWITCH
- CS CENTRIFUGAL SWITCH
- FUSE
- IRC RUN CAPACITOR
- IT TRANSFORMER
- ⊗ IDENTIFIED RUN CAPACITOR
- △ 24V CONNECTION ROOM THERMOSTAT
- FIELD CONNECTION
- FACTORY WIRING AND DEVICES
- CHANTIER WIRING AND DEVICES

**LADDER DIAGRAM
(DIAGRAMME ÉLÉMENTAIRE)**

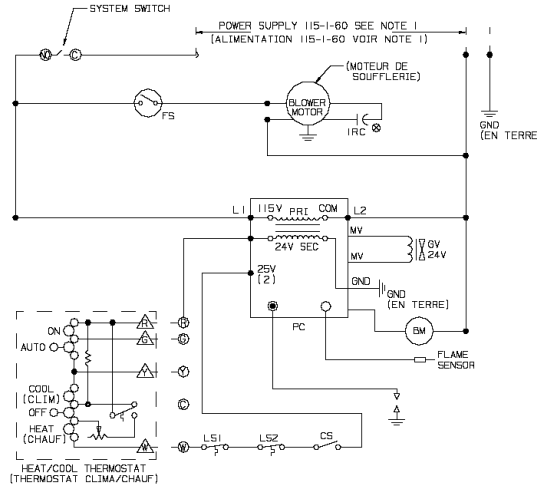

NOTES:

1. ALL FIELD WIRING PER: (A) NATIONAL ELEC. CODE (NEC) AND/OR/ (B) CANADIAN ELEC. CODE (CEC) AND/OR/ (C) LOCAL OR CITY CODES.
2. IF ANY OF THE ORIGINAL WIRE AS SUPPLIED WITH THE FURNACE MUST BE REPLACED, IT MUST BE REPLACED WITH WIRING MATERIAL HAVING A TEMPERATURE RATING OF AT LEAST 221°F (105°C).
3. CONNECTORS SUITABLE FOR COPPER CONDUCTORS ONLY.
4. ALL REPLACEMENT COMPONENTS MUST BE PROPERLY GROUNDED.
5. PROVIDE DISCONNECTS FOR ALL POWER SUPPLIES.
6. MOTORS ARE INHERENTLY PROTECTED.

LÉGENDE

- BM MOTEUR DU BRÛLEUR
- PC CONTRÔLE PRIMAIRE
- IT TRANSFORMATEUR D'IGNITION
- RI RELAIS
- SV SOUPE DE SOLENOÏDE
- PC CONTRÔLE PRIMAIRE
- P1/S1 LE MOTEUR DE LA SOUFFLERIE DOUBLE ET BOUCHON A 9 PIGES SUR
- LS1 COMMUTEUR DE LIMITE PRINCIPALE
- LS2 COMMUTEUR DE LIMITE
- CS COMMUTEUR CENTRIFIQUE
- FUSIBLE
- IRC CAPACITEUR DE FONCTIONNEMENT IDENTIFIE
- IT TRANSFORMEUR
- ⊗ CAPACITEUR DE FONCTIONNEMENT IDENTIFIE
- △ 24V RACCORDEMENT DU THERMOSTAT DE PIECE
- RACCORDEMENT DE CHANTIER
- FILAGE DE L'USINE ET APPAREILS
- FILAGE DE CHANTIER ET APPAREILS

IF ANY OF THE ORIGINAL WIRE SUPPLIED WITH THIS UNIT MUST BE REPLACED, IT MUST BE REPLACED WITH TYPE 105°C THERMOPLASTIC OR ITS EQUIVALENT.

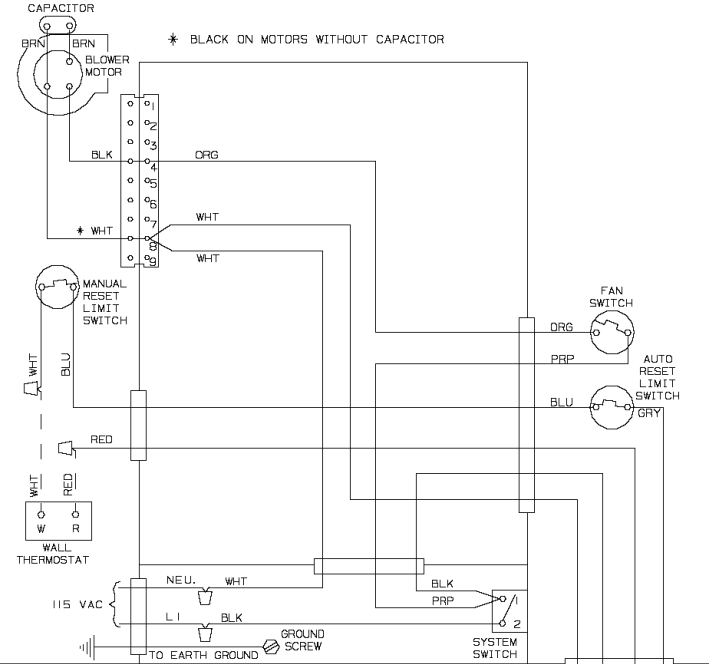

INCOMING POWER MUST BE POLARIZED, OBSERVE COLOR CODING.
L'ALIMENTATION DU COURANT DOIT ÊTRE POLARISÉE. SUIVEZ
LES CODES DE COULEURS.

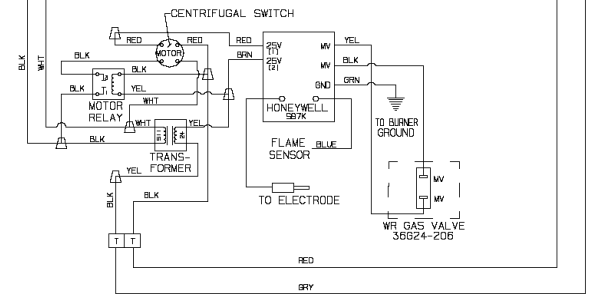

125525-UWD-A-0705

NOTES