

INSTALLATION MANUAL

DOWNFLOW/UPFLOW
ELECTRIC FURNACE
MODELS: EB SERIES

TABLE OF CONTENTS

GENERAL INFORMATION	2
EB FURNACE NOTES	2
CODES	2
LOCATION	2
FURNACE CLEARANCE	2
RETURN AIR	2
DUCT SYSTEM DESIGN	3
DOWNFLOW FURNACE INSTALLATION (WITH 7900 SERIES DUCT CONNECTOR)	3
DUCT CONNECTORS (7990 SERIES)	4
INSTALLATION OF SCREW ATTACHMENT DUCT CONNECTOR (7990 SERIES)	5
INSTALLATION OF TAB ATTACHMENT DUCT CONNECTOR (7990 SERIES)	5
INSTALLATION OF THE FURNACE	6
FURNACE CONVERSION TO UPFLOW APPLICATION	6
WIRING	7
THERMOSTAT INSTALLATION	9
OPTIONAL AIR CONDITIONING ACCESSORIES	10
HIGH PERFORMANCE BLOWER ACCESSORY PACKAGE	11
WIRING DIAGRAMS	11
REPAIR PARTS LIST	17

CAUTION: READ ALL SAFETY GUIDES
BEFORE YOU START TO INSTALL
YOUR UNIT.

SAVE THIS MANUAL

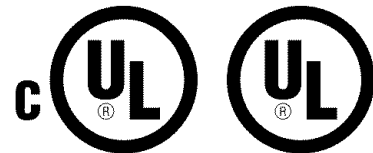
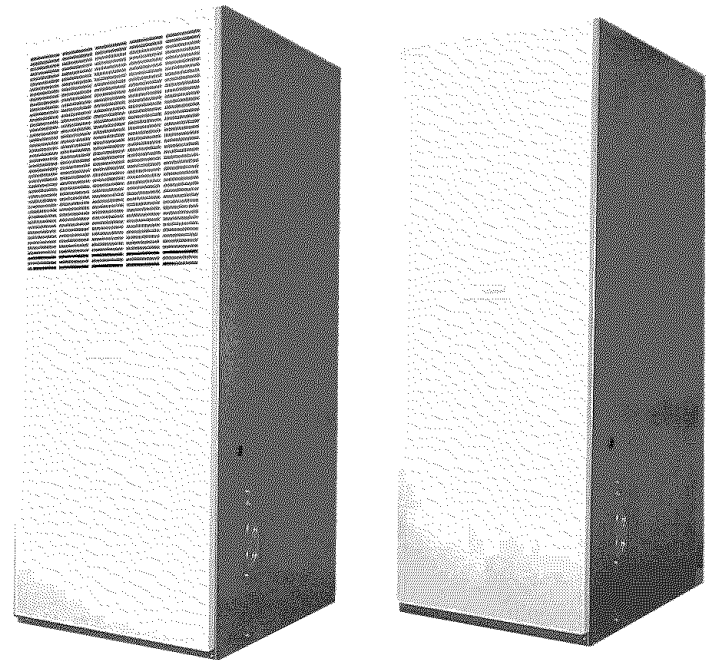

▲ WARNING

Incorrect installation may create condition where the operation of the product could cause personal injury or property damage.

The furnace shall be installed so the electrical components are protected from water.

▲ CAUTION

This product must be installed in strict compliance with the enclosed installation instructions and any applicable Local, State and National Codes including, but not limited to building, electrical, and mechanical codes. Improper installation will void the warranty.

GENERAL INFORMATION

EB FURNACE NOTES

The following list includes important facts and information regarding the EB furnace and its packaging inclusions:

1. Furnace is rated at 240 volts, 60 Hz, single phase.
2. Heating and Cooling thermostat is packed with furnace.
3. Filters are furnished with each model.
4. Filter size is universal to all models - 16 x 20 x 1.

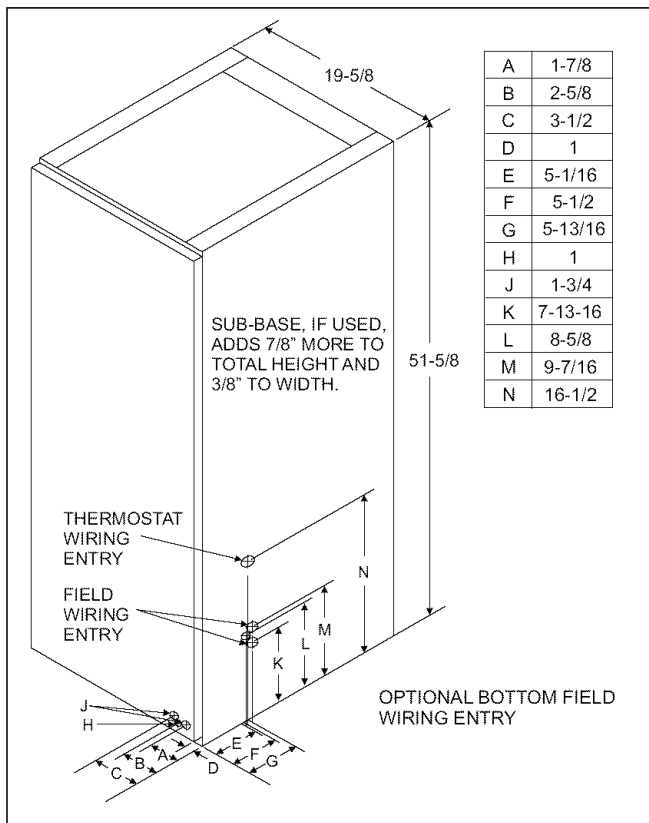

FIGURE 1 : FURNACE DIMENSIONS

5. Furnace size is the same for all models. See Figure 1.
6. Four-wire thermostat operation for heating and cooling.
7. Coil cavity built into furnace.
8. All furnaces are equipped with an air conditioner blower and is A/C or Heat Pump ready.
9. Holding strap furnished on top rear of furnace.
10. This furnace is designed for downflow application; however, it may be converted to an upflow application. (See Page 6 for upflow conversion instruction.)
11. This furnace must not be operated without the front panel installed.

NOTE: This furnace and its components listed on the A/C and Heat Pump equipment sticker were listed in combination as a system by Underwriter's Laboratories for the United States and Canada.

CODES

The electric furnace must be installed in accordance with the following codes:

- Standard for the Installation of Air Conditioning and Ventilating Systems (NFPA 90A)
- Standard for the Installation of Warm Air Heating and Air Conditioning Systems (NFPA 90B)
- National Electric Code (NFPA 70)
- Canadian Electrical Code, Part I (CSA C22.1)
- All local codes (state/county/township).

NOTE: All applicable codes take precedence over any recommendation made in these instructions.

LOCATION

Access for servicing is an important factor in the location of any furnace. Provide a minimum of 24 inches in front of the furnace for access to the heating elements and controls. This access may be provided by a closet door or by locating the furnace 24 inches from a facing wall or partition.

FURNACE CLEARANCE

Electric furnace is approved for zero (0) in. clearance to combustible material on all or any part of the furnace exterior and the inlet or outlet duct work. Clearances must be provided above the furnace for a minimum of 200 sq. inches free opening for return air. For clearances other than shown above see paragraph on Return Air.

RETURN AIR

In order for the furnace to work properly, a closet or alcove must have a certain total free area opening for return air.

FOR HEATING ONLY FURNACE

Minimum 200 in² free area opening.

Use Return Grille 7900-287P/B,

Or any Return Grille with minimum 200 in² free area opening.

FOR A/C UP TO 4-TONS AND HP UP TO 3 1/2-TONS

Minimum 250 in² free area opening.

Use Return Grille 7900-287P/B, 1FG0620BK (hinged),

Or Louvered Door 3500-1581, 3500-5851 (bulk pack),

Or any Return Grille with minimum 250 in² free area opening.

FOR A/C UP TO 5-TONS AND HP UP TO 4-TONS

Minimum 330 in² free area opening.

Use Return Grille 1RF1025BK, 1FG0125 (hinged),

Or Louvered Door 3500-1591, 3500-5861 (bulk pack),

Or any Return Grille with minimum 330 in² free area opening.

The return air opening can be located in a closet front door or a sidewall above the furnace casing, or in a louvered door on the furnace. If opening for the return air is located in the floor, side walls or closet door anywhere below furnace casing height, 6 inches minimum clearance must be provided on the furnace side where return is located to provide for proper air flow. See Figure 2. The 6 " minimum clearance is not required if there is a return grille installed above the furnace height. This return grille cannot start more than three feet above the furnace height.

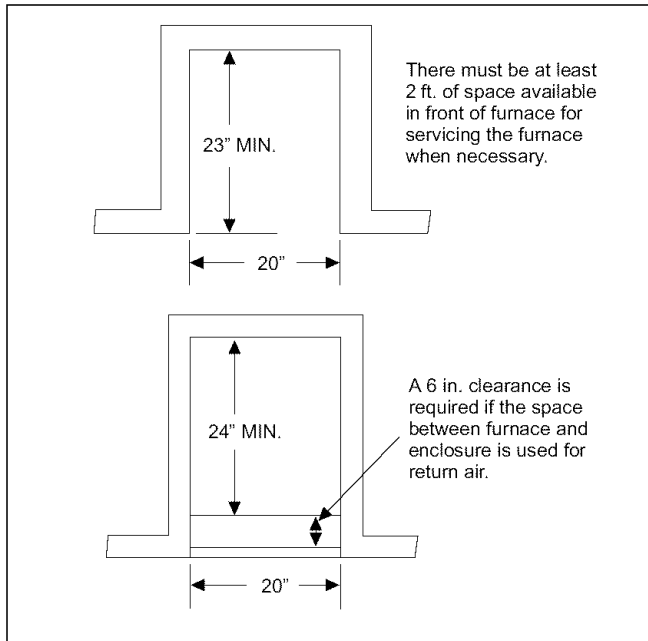

FIGURE 2 : ALCOVE & CLOSET CLEARANCES

For Upflow installations, a closet 32 inches wide by 30 inches deep with a 30-inch wide door is necessary. See Figure 3.

When installing furnace in a separate closet or room which is accessible only through an outside door, a minimum of 200 sq. in. free opening for return air must be provided. The supply and return air must be ducted, securely attached and be sealed to the furnace casing if there are grilles in the outside door to the closet. Openings where ducts pass through walls, the floor or the ceiling must be sealed to prevent air leakage into or from closet and the living area.

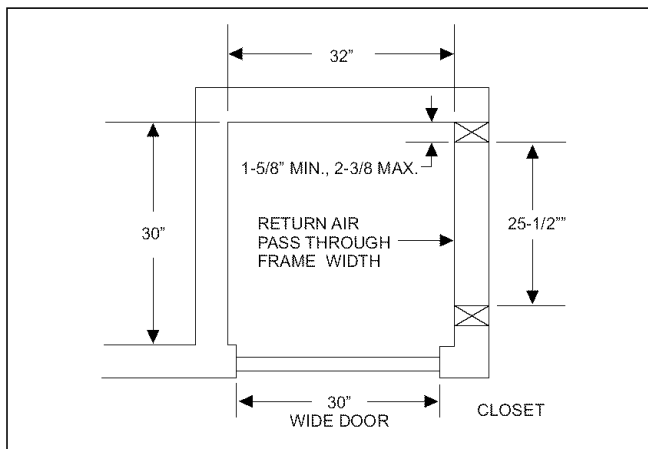

FIGURE 3 : UPFLOW CLOSET CLEARANCE

Provisions shall be made to permit the return of circulating air from all rooms and living spaces, except the bathroom(s) to the circulating air supply inlet of the furnace. Failure to comply may cause improper heating and may cause the furnace to cycle on the limit.

DUCT SYSTEM DESIGN

Electric furnace is designed to operate at a given static pressure.

In order to assure proper air flow through the furnace, the distribution system must be designed so that the static pressure external to the furnace does not exceed the static pressure rating shown on the furnace rating plate. See Table 3.

The number, size and placement of registers should be such that even distribution of heat is provided throughout the home.

DOWNFLOW FURNACE INSTALLATION (WITH 7900 SERIES DUCT CONNECTOR)

We have redesigned our duct connector to eliminate the sub-base requirement. Table 1 will help you in deciding the part number of the new duct connector you need.

If you are installing a new duct connector (7900 Series), refer to the following instructions. Read carefully the instructions provided before starting the installation.

Provide adequate clearance for servicing.

1. Locate furnace conveniently away from wall facing or partitions to permit easy removal of components.
2. A minimum of six (6) inches should be maintained between the furnace and closet door when door is used for return air. See Figure 2.
3. Two (2) feet of space must be available in front of furnace for future servicing (blower or element removal, furnace removal, etc.).

Table 1: DUCT CONNECTOR FOR ELECTRIC FURNACES

FLOOR TO DUCT DIMENSIONS	FINGERED STYLE	SCREW TAB STYLE
1"	7990-6211	7990-6011
2"	7990-6221	7990-6021
3"	↑↓	↑↓
4"	7990-6241	7990-6041
5"	↑↓	↑↓
6"	7990-6261	7990-6061
7"	7990-6271	7990-6071
8"	7990-6281	7990-6081
9"	↑↓	↑↓
10"	7990-6301	7990-6101
11"	↑↓	↑↓
12"	7990-6321	7990-6121
13"	↑↑	↑↑
14"	NA	NA
15"	NA	NA

- ↑↓ - Indicates connector above or below could be used depending on tolerance in floor to duct dimension.
- ↑↑ - Indicates connector above could be used depending on tolerance in floor to duct dimension.
- ↓↓ - Indicates connector below could be used depending on tolerance in floor to duct dimension.

DUCT CONNECTORS (7990 SERIES)

These duct connectors are for connecting the furnace to an under the floor supply duct system. The furnace may be installed on combustible flooring without a separate sub-base.

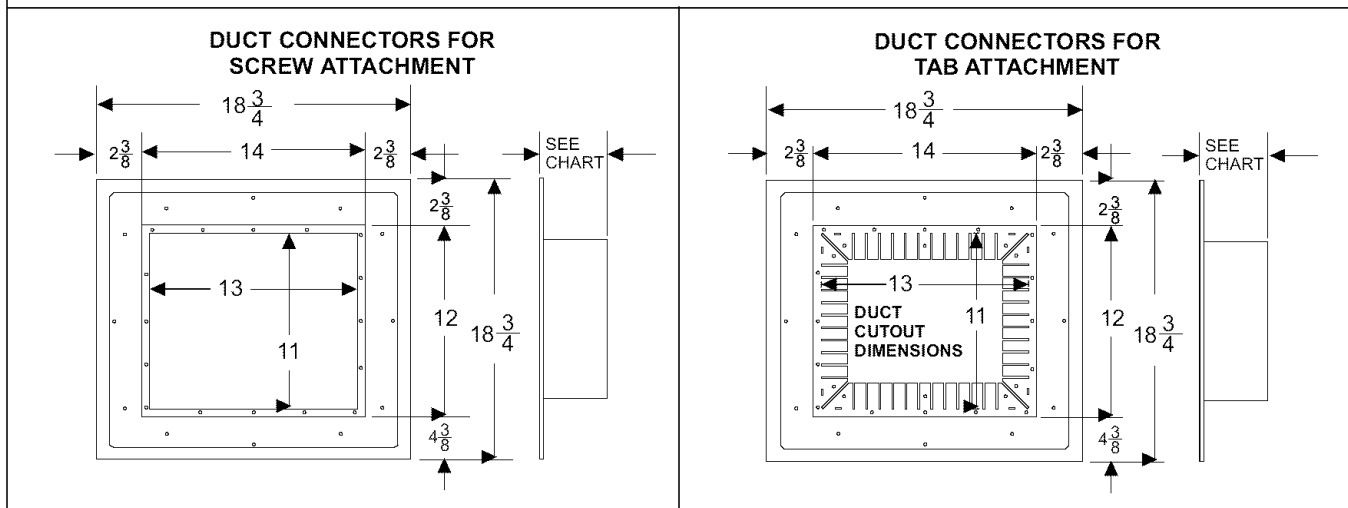

FIGURE 4 : DUCT CONNECTOR DIMENSIONS (7990 SERIES)

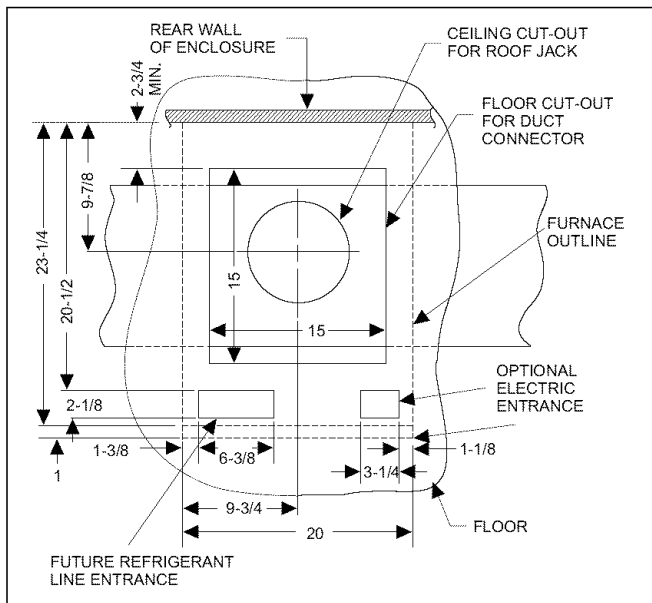

FIGURE 5 : RECOMMENDED FLOOR CUT-OUT (7990 SERIES)

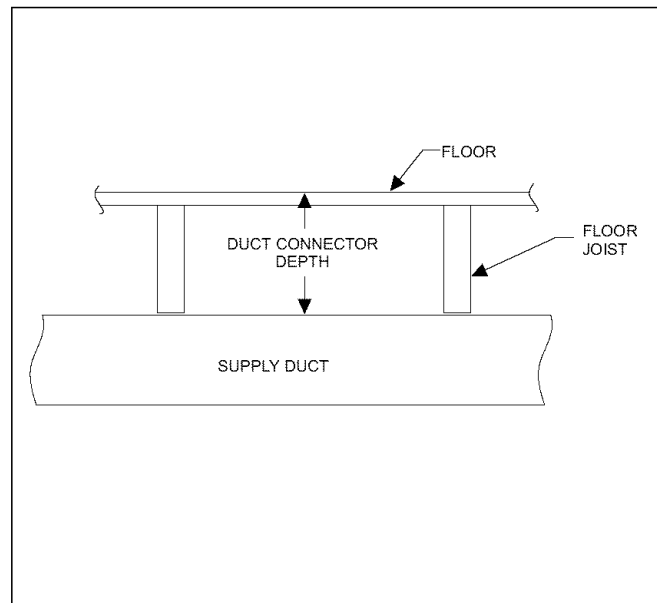

FIGURE 6 : DUCT CONNECTOR DEPTH (7990 SERIES)

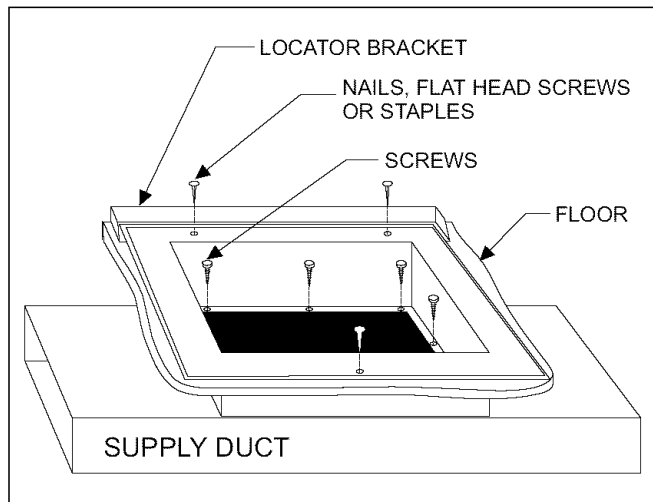

FIGURE 7 : DUCT CONNECTOR SCREW ATTACHMENT (7990 SERIES)

INSTALLATION OF SCREW ATTACHMENT DUCT CONNECTOR (7990 SERIES)

1. Make floor cut out as shown in Figure 5.
2. Determine the depth of the floor cavity from the surface of the floor to the top of the supply air duct and select the appropriate duct connector from the chart.
3. Place locating bracket (supplied with the duct connector) to the back edge of the floor opening. See Figure 7.
4. Apply a water based duct sealant to the 1/2" supply duct attachment flange of the duct connector.
5. Determine which of the four positions the duct connector best centers over the supply duct and insert it through the floor cutout.
6. When properly aligned with the supply duct, secure the duct connector to the floor with nails, flat head screws or staples.
7. Use screws as required to secure the duct connector to the supply duct.
8. Cut out the opening to the supply duct. If sealant was not used, the installer should tape the mating flanges to provide a good air seal.

NOTE: Duct sealant and tape must be classified as meeting HUD Standard 3280.715, U.L. Standard 181A. Tape used to provide a better air seal should be approved by the applicable National or Local Code.

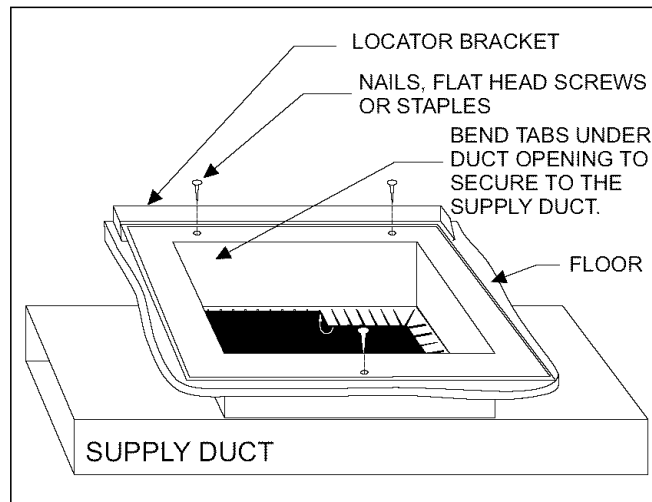

FIGURE 8 : DUCT CONNECTOR TAB ATTACHMENT (7990 SERIES)

INSTALLATION OF TAB ATTACHMENT DUCT CONNECTOR (7990 SERIES)

1. Make floor cut out as shown in Figure 5.
2. Determine the depth of the floor cavity from the surface of the floor to the top of the supply air duct and select the appropriate duct connector from the chart.
3. Place locating bracket (supplied with the duct connector) to the rear of the floor area for the furnace. See Figure 8.
4. Determine which of the four positions the duct connector best centers over the supply duct and insert it through the floor cutout.
5. Mark cut-out location on the supply duct and remove the duct connector.
6. Cut out the opening to the supply duct.
7. Bend tabs down through and back up under the supply duct.
8. Secure the duct connector to the floor with nails, flat head screws or staples.

The duct connector is designed for use on ducts down to 12" in width. When using the connector on smaller width ducts, there will not be sufficient clearance to bend the tabs on two sides of the duct connector.

In such cases the tabs may be attached to the sides of the duct by using sheet metal screws or other suitable fasteners. Holes for sheet metal screws are provided in three (3) tabs on each side of the duct connector. If more than 3 tabs need to be used to provide a more secure and air tight connection, the remaining tabs can also be fastened to the duct with screws after drilling the required screw holes.

PARALLEL DUCT SYSTEM

The EB Duct Connector Insert 37323716001 may be used on EB Series Electric Manufactured Housing Furnaces where the duct system runs parallel to the furnace. See Figure 9. The EB Duct Connector Insert should not be used if the duct system runs perpendicular to the furnace or if the duct system extends only one direction from the furnace.

The Duct Connector Insert cannot be used with 1" and 2" Duct Connectors (7990-6011, 7990-6021, 7990-6211, and 7990-6221).

Follow Accessory Kit Installation Instruction 035-20632-001 provided with the Duct Connector Insert.

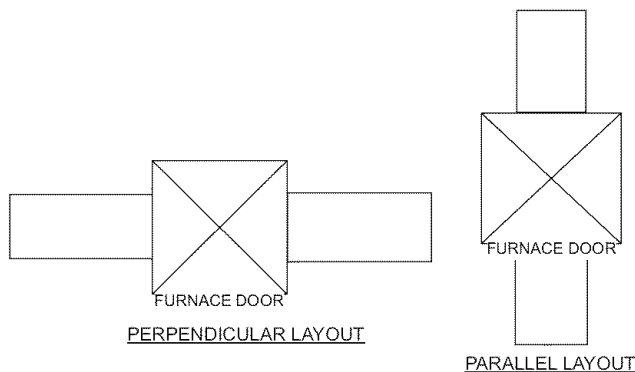

FIGURE 9 : DUCT SYSTEM CONFIGURATION

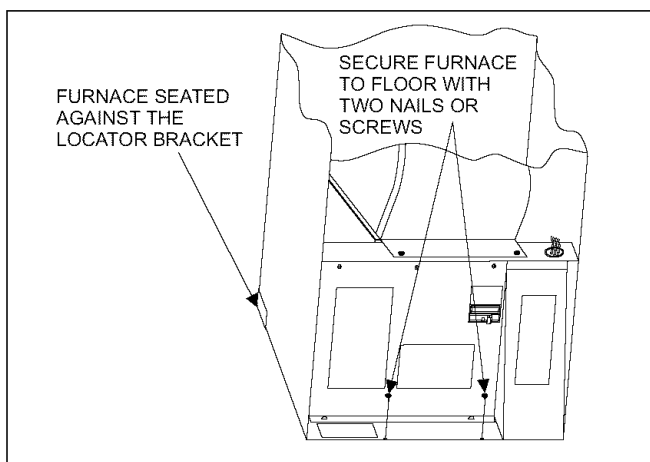

FIGURE 10 : INSTALLATION OF FURNACE

INSTALLATION OF THE FURNACE

1. Remove the front panels and set the furnace onto the duct connector. Slide it back until the rear of the unit engages the locator bracket.
2. Secure the front of the furnace with two screws at the mounting holes provided. See Figure 10.
3. Secure the top of the furnace to a structural member using screw through the strap at the top of the furnace. Strap may be moved to any of the holes located along the top back of the furnace. Installer may provide an equivalent method, such as screws through the casing side.

FURNACE CONVERSION TO UPFLOW APPLICATION

Upflow furnace conversion is easily accomplished by following the steps listed below:

Provide adequate clearance for servicing:

1. Before Conversion, locate the furnace conveniently away from wall facing or partitions to permit easy removal and installation of components.
2. Two (2) feet of space must be available in front of furnace for future servicing (blower or element removal, furnace removal, etc.).

3500-5451* Adapter Box and/or 3500-7211* Upflow Flange Plate Kit are needed prior to following steps below:

1. Assemble the 3500-5451 filter box per installation provided with kit.
2. Remove furnace panel.
3. Remove air filter.
4. Remove strap on the top of the unit, saving the screw and strap for later use.
5. Turn entire unit upside-down, so the filter box is on the floor.
6. Remove two (2) screws that are on the front of the unit at the top. Obtain front panel hanger angle from the upflow kit 3500-7211*. Secure the hanger angle with two (2) screws removed from the furnace casing. See Figure 11.

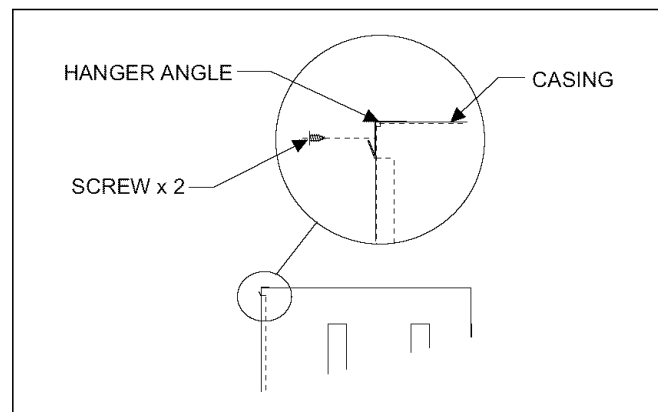

FIGURE 11 : HANGER ANGLE ATTACHMENT

7. Attach the strap that was removed in Step 4 to the top, side or back of the furnace.
8. Install the duct flange plate on top of the inverted furnace as shown in Figure 12.
9. If installing POS, Standard or Deluxe Air Systems, proceed to Step 10.
Optional start collar for the Economy POS system shipped with 3500-7211* can be used for blend air flex duct installation. Punch the lineset knockout out and position the start collar over it. Duct connector edge can be pushed under the casing flange and screws provided can be used to capture the other end of duct connector. Secure collar to top of furnace.

10. Flange plate shipped with 3500-7211* is mounted to the furnace with eight (8) screws provided. Two (2) blunt screws are for the holes in the front of the furnace. See Figure 12.
11. If upflow adapter box kit 3500-5451* is not used, then our optional filter bracket is provided with 3500-7211* kit. This filter bracket maybe used to retain filter inside its original location in the furnace.
12. Secure the top of the furnace to a structural member using screws and the strap on top of the furnace. The mobile home manufacturer may provide an equivalent strap, if required, to secure the furnace.
13. If excessive movement is expected, then some blower support is recommended.

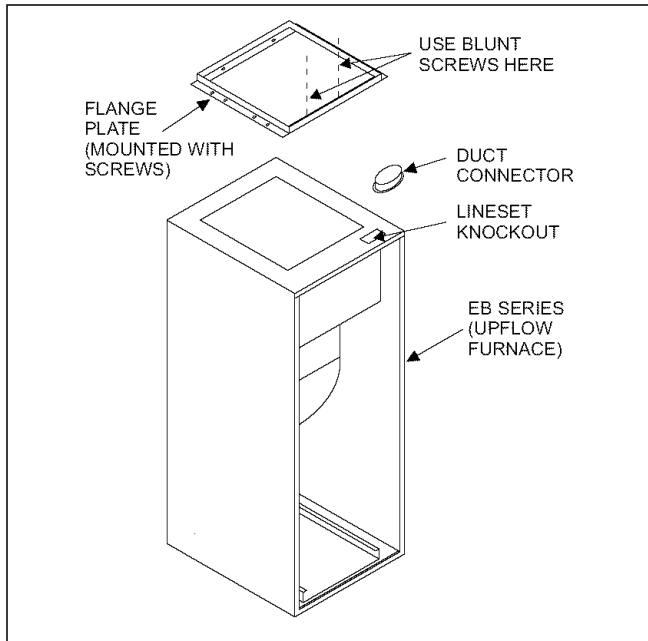

FIGURE 12 : BLOWER BRACKET AND DUCT FLANGE ATTACHMENT

WIRING

Furnace wiring is complete except for the power supply and the thermostat wires. See wiring diagram (or Table 2) for wire and fuse size. See Table 2 for ground wire sizes. Thermostat wires connect through side of furnace and should also be no smaller than 22 gauge. Power wires can enter through the side of the unit or through the auxiliary entrance, located in the bottom of the unit. (See Figure 1). When bringing wiring through the bottom of the furnace, cable connectors must be installed to hold wiring in place and to relieve any strain on the wiring. These connectors will also serve as a seal between the furnace and the floor. Thus, additional sealing is not required.

(Refer to the National Electrical Code, Canadian Electrical Code and local codes for wiring material requirements.

NOTE: The furnaces are equipped with either one or two 60 amp circuit breakers. These circuit breakers protect the wiring inside of the furnace in the event of a short circuit. Additionally, these breakers provide a means of disconnecting the power to the unit. The circuit breakers in the furnace are not meant to protect the branch circuit wiring between the furnace and the home's breaker panel. General wire and breaker sizes are shown in Table 2. If sheathed cable is used, refer to National Electrical Code, Canadian Electrical Code and local codes for additional requirements concerning supply circuit wiring. Electrical Data can be found in Table 4.

IMPORTANT - All installation on field wiring must be rated at 60°C or higher. Please refer to the wiring diagrams on the furnace or this book for more information.

Table 2:

MODELS	EB23B		EB20B		EB17B		EB15B		EB12B	EB10B
Single Branch Circuit Service *	2 Leads + 1 Ground CKT#1									
Nominal Circuit Load - AMPS	94.0		84.0		70.7		64.1		50.7	44.0
Minimum Wire Size (90°)	#2		#3		#4		#4		#6	#8
Minimum Wire Size (75°)	#1		#2		#3		#4		#6	#6
Minimum Wire Size (60°)	#0		#1		#2		#3		#4	#6
Ground Wire Size +	#6		#6		#8		#8		#8	#10
Max. Fuse (or C.B.) - AMPS	125		110		90		90		70	60
Dual Branch Circuit Service	CKT #1	CKT #2	CKT #1	CKT #2	CKT #1	CKT #2	CKT #1	CKT #2	NOT APPROVED	
Branch Circuit Load - AMPS	47.3	46.7	44.0	40.0	47.3	23.4	44.0	20.1		
Branch Circuit Min. - AMPS	59.2	58.4	55.0	50.0	59.2	29.3	55.0	25.2		
Minimum Wire Size (90°)	#6	#6	#8	#8	#6	#10	#8	#10		
Minimum Wire Size (75°)	#6	#6	#6	#8	#6	#10	#6	#10		
Minimum Wire Size (60°)	#4	#4	#6	#6	#4	#10	#6	#10		
Ground Wire Size +	#10	#10	#10	#10	#10	#10	#10	#10		
Max. Fuse (or C.B.) - AMPS	60	60	60	50	60	30	60	30		

* Requires Jumper Bars (P/N 3500-3781*) - Dual Supply for U.S. Only.
 Refer to National Electrical Code. Table 310-16 for Non-Sheathed Conductors.
 + Refer to National Electrical Code. Table 250-95 for Non-Sheathed Conductor Ground Wire.

Table 3: EB SERIES BLOWER PERFORMANCE

Low Speed Heating Speed Models EB10, 12, 15	Static Pressure (Inches of WC)	.0	.1	.2	.3	.4	.5	.6	.7	.8
	CFM (STD. Air)	945	936	936	924	915	889	870	813	705
Medium Speed Heating Speed Models EB17, 20, 23	Static Pressure (Inches of WC)	.0	.1	.2	.3	.4	.5	.6	.7	.8
	CFM (STD. Air)	1160	1145	1145	1140	1129	1109	1073	1027	935
Medium High with A-Coil in place	Static Pressure (Inches of WC)	.0	.1	.2	.3	.4	.5	.6	.7	.8
	CFM (STD. Air)	1340	1317	1290	1252	1208	1158	1095	1021	876
High with A-Coil in place	Static Pressure (Inches of WC)	.0	.1	.2	.3	.4	.5	.6	.7	.8
	CFM (STD. Air)	1573	1534	1490	1435	1369	1309	1237	1135	1019

Table 4: ELECTRICAL DATA

MODEL NUMBER		EB23B	EB20B	EB17B	EB15B	EB12B	EB10B	
D.O.E. Output	240 VAC 60 Hz. 1 Phase	BTU	77,000	67,000	56,000	51,000	39,000	34,000
		KW	22.6	19.6	16.4	15.0	11.4	10.0
OUTPUT CAPACITY	230 VAC 60 Hz. 1 Phase	BTU	71,000	61,000	52,000	47,000	36,000	31,000
		KW	20.8	17.9	15.2	13.8	10.6	9.1
	220 VAC 60 Hz. 1 Phase	BTU	65,000	57,000	48,000	43,000	33,000	29,000
		KW	19.1	16.7	14.1	12.6	9.7	8.5
Element Capacity @ 240 VAC		KW	21.6	19.2	16.0	14.4	11.2	9.6
		AMPS	90.0	80.0	66.7	60.0	46.7	40.0
Motor AMPS @ 240 V.		4.0 Maximum						
Circuit Load AMPS @ 240 V.		CKT 1	47.3	44.0	47.3	44.0	50.7*	44.0 ¹
		CKT 2	46.7	40.0	23.4	20.0		

¹. Approved for Single Branch Circuit Service Only

Casing or Cabinet must be Permanently Grounded in Accordance with National Electrical Code or other Applicable Codes.

Models for EB23B, EB20B, EB17B and EB15B may be connected to a single or dual branch circuit. (See Table 2.)

These units are shipped from the factory set up for dual power supply connections. For single power supply connec-

tions, jumper bars (P/N 3500-378P*) are required and are available from the factory. Model for EB12B is factory shipped with jumper bars in place.

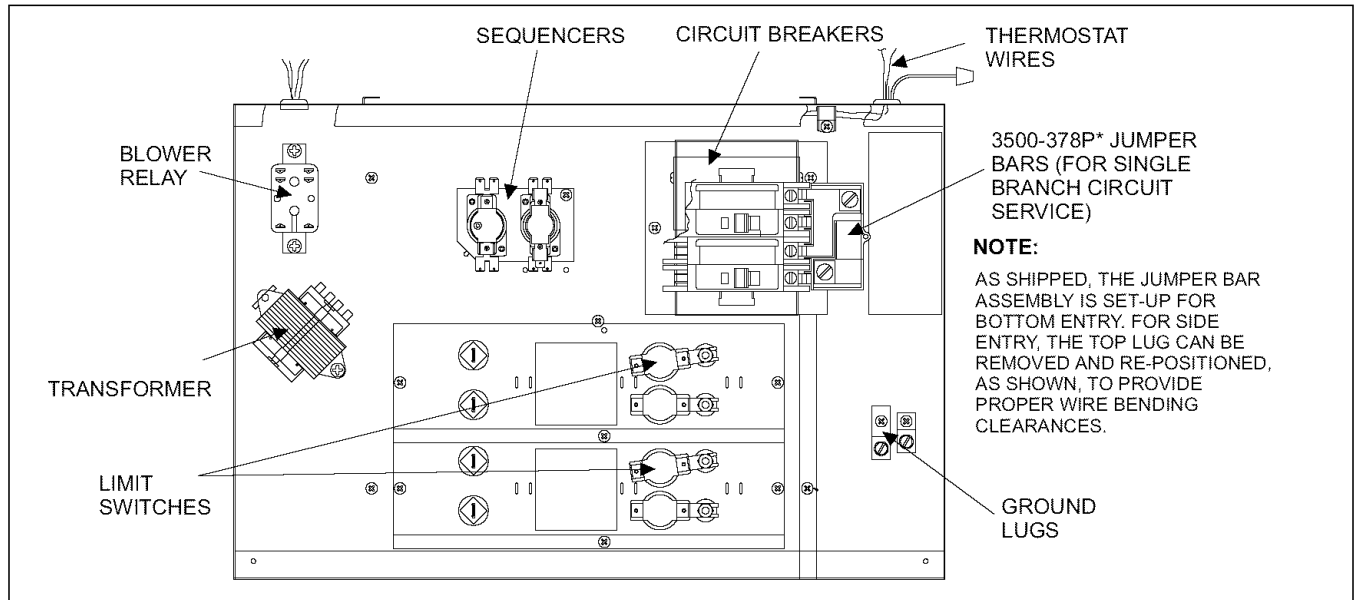

FIGURE 13 : CONTROL BOX

⚠ WARNING

For personal safety be sure to turn the electrical power "OFF" at the household service box and at the furnace circuit breakers before attempting any service or maintenance operations. Homeowners should never perform any maintenance which requires opening electric box door.

Furnace is equipped with a protective shield over field wiring connection. When field wiring is completed, shield must be replaced to prevent hazard of electrical shock when using furnace disconnect. (See Figure 14.)

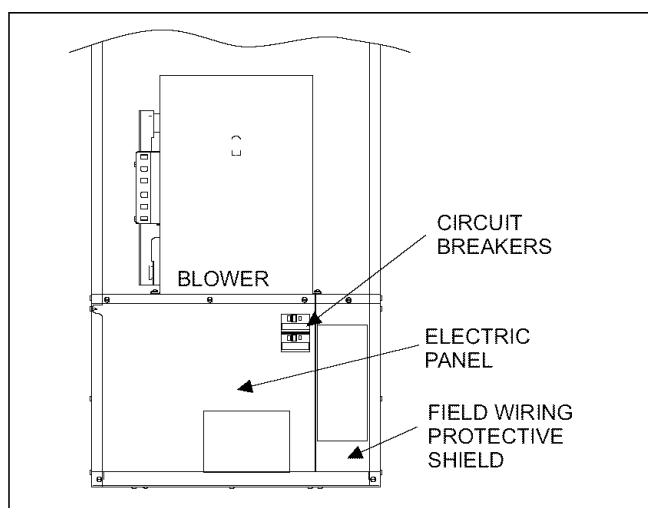

FIGURE 14 : FIELD WIRING SHIELD

THERMOSTAT INSTALLATION

The adjustable heat anticipator in the thermostat is pre-set at 0.4 Amps. This setting should be checked at the time of installation

In some cases the thermostat may be a "self-setting" type in which case no Amp. setting will be found on the thermostat, eliminating the need for any field adjustment.

Thermostat should be located on an inside wall in an open area to more closely regulate average room air, preferably, where there is air movement back to furnace. Care should be used to locate thermostat away from hot air discharge openings, lights, etc. Locating height of thermostat is important. Thermostat should be located 52 to 66 inches above the floor. This is sometimes called the comfort zone.

If a condenser with its own Transformer shares a Heat/Cool Thermostat with this furnace, use a thermostat with isolating contacts to prevent interconnection of Class II 24 Volt Systems.

Cycle furnace to make sure it will operate correctly.

Maintenance and operating instructions are in the customer envelope accompanying the furnace.

Give the customer envelope to the home owner.

CAUTION

When using separate thermostats, a thermostat interlock system must be provided to prevent simultaneous operation of the furnace and air conditioner. Simultaneous operation can result in coach overheating, equipment damage and energy waste. (See Figures 15 and 16.)

Do not connect Yellow wire to thermostat until an outdoor unit is installed.

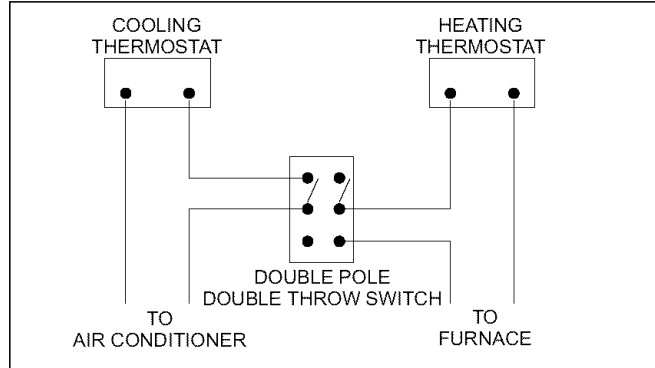
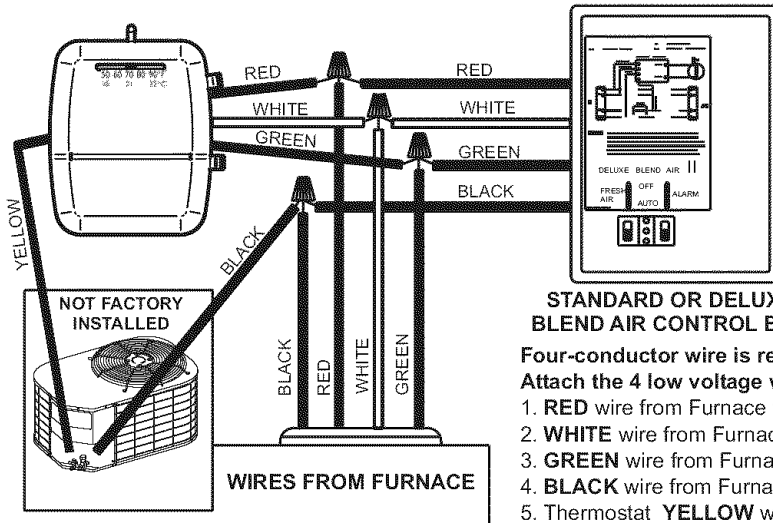

FIGURE 15 : THERMOSTAT WIRING

The EB*B* Furnaces are A/C ready.
All furnaces installations should include a minimum of four conductor thermostat wiring to accommodate future air conditioning installations.

THERMOSTAT WIRING SCHEMATIC FOR: BLEND AIR AND FURNACE



STANDARD OR DELUXE BLEND AIR CONTROL BOX

Four-conductor wire is required for thermostat connection.

Attach the 4 low voltage wires extending from the control box as follows:

1. RED wire from Furnace to thermostat RED wire.
2. WHITE wire from Furnace to thermostat WHITE wire.
3. GREEN wire from Furnace to thermostat GREEN wire.
4. BLACK wire from Furnace to condensing unit contactor.
5. Thermostat YELLOW wire to condensing unit contactor.

FIGURE 16 : THERMOSTAT WIRING

OPTIONAL AIR CONDITIONING ACCESSORIES

WARNING

Failure to install this insulation and coil shelf kit could result in damage to equipment and/or personal injury. Liability and warranty from the manufacturer could also be void.

This furnace is already equipped with a blower and control system to add-on air conditioning up to 4 tons and heat pump up to 3-1/2 tons. Insulation and coil shelf kit (3500-8941* for downflow or 3500-8961* for upflow) must be installed when adding on such remote air conditioning systems.

HIGH PERFORMANCE BLOWER ACCESSORY PACKAGE



All areas around the line sets, drain hoses and other openings in the coil shelf should be sealed air tight. Use some moldable compound or caulking to seal the area. Failure to do so may result in loss of performance and premature compressor failure.

All EB furnaces are already equipped with a blower and control system to add-on air conditioning up to 4-tons and heat pump up to 3 1/2-tons. If the requirement is to achieve more than specified than the production blower inside the furnace would have to be replaced with an accessory blower package 3500-7901*. This accessory blower package would deliver air conditioning up to 5-tons, and heat pump up to 4-tons. Accessory package (3500-7901*) includes blower, insulation, coil shelf, trap, clamps, etc. Please refer to the installation instructions packed with the accessory package for more information.

WIRING DIAGRAMS

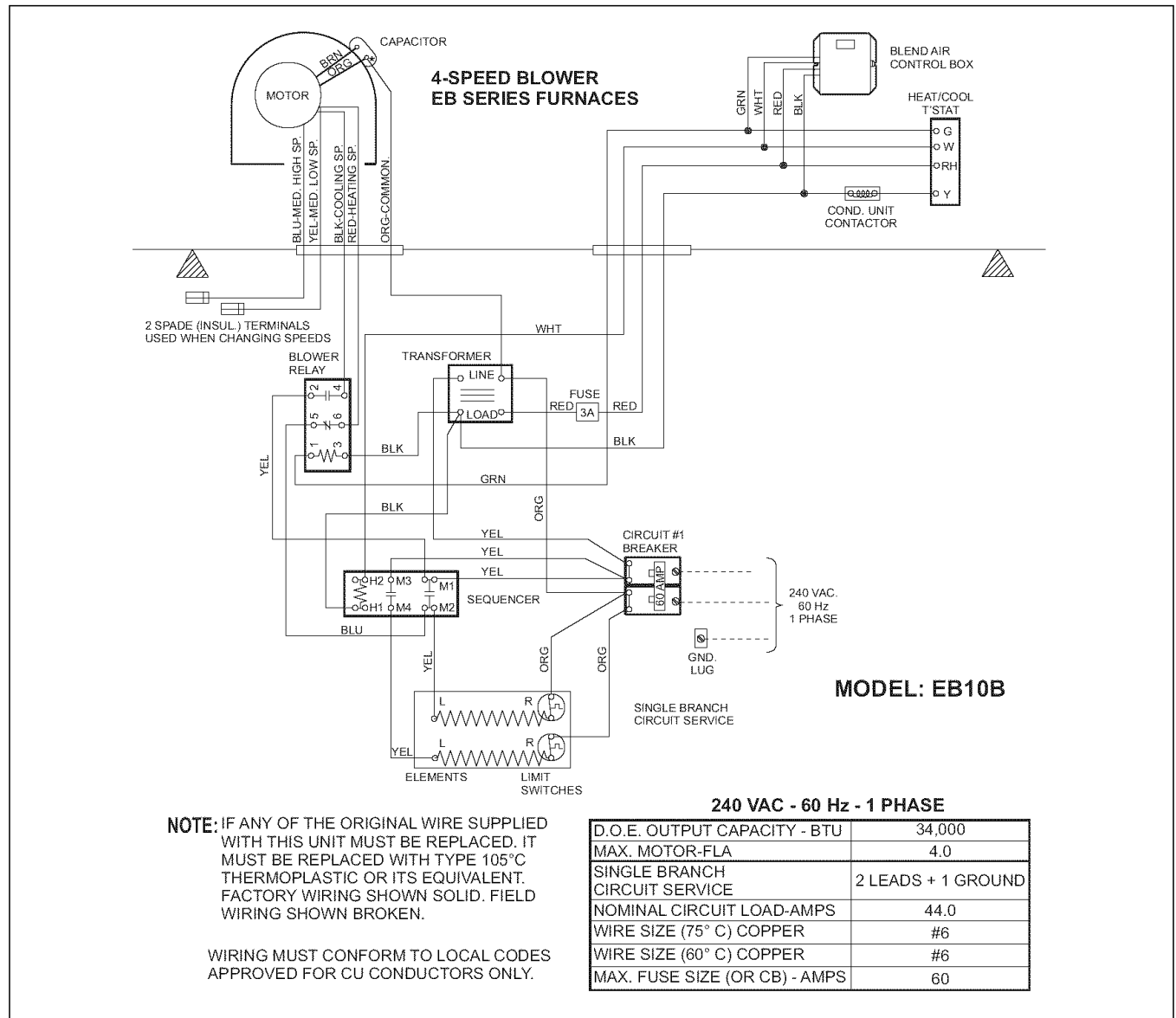

FIGURE 17 : EB10B WIRING DIAGRAM

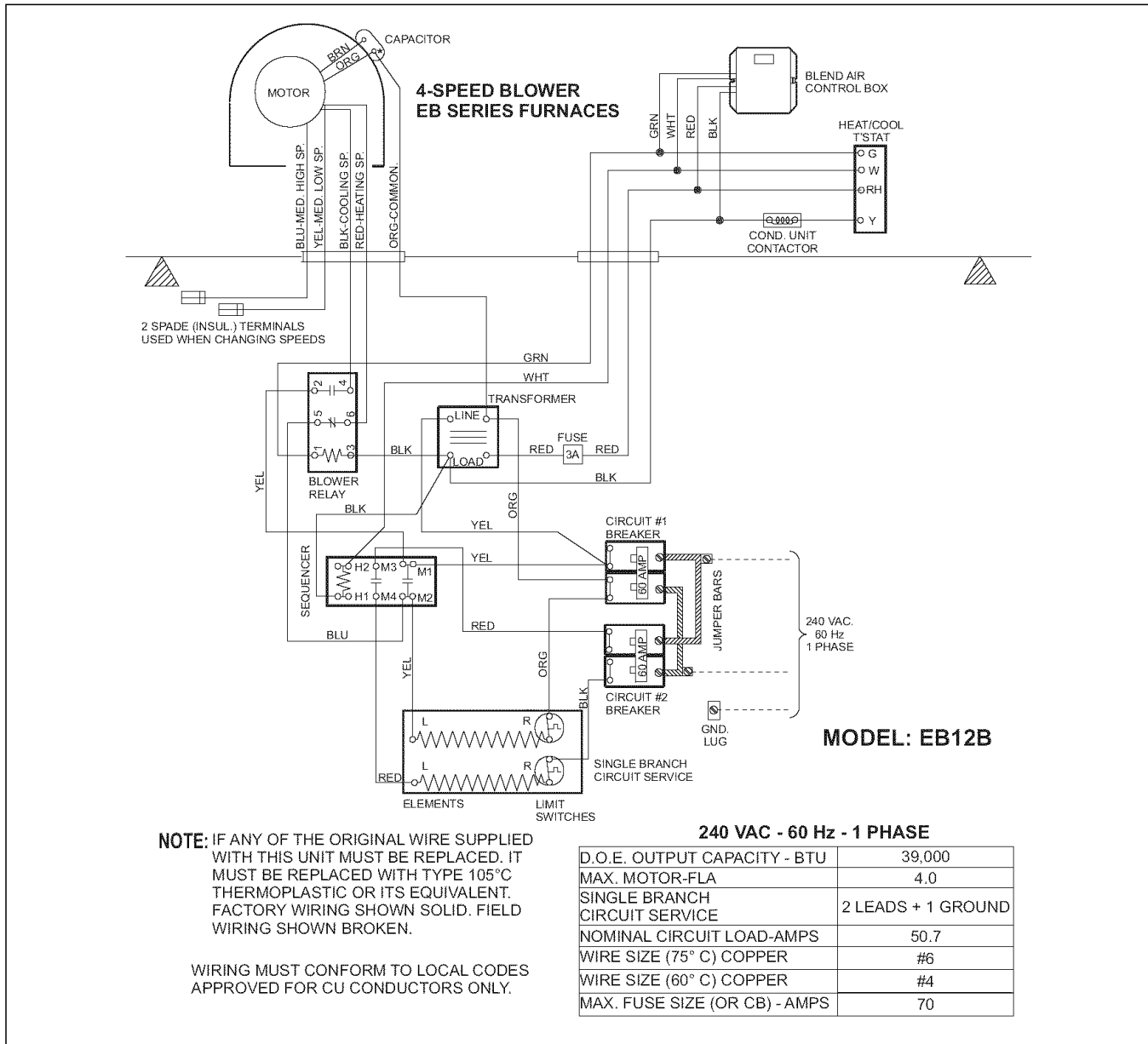

FIGURE 18 : EB12B WIRING DIAGRAM

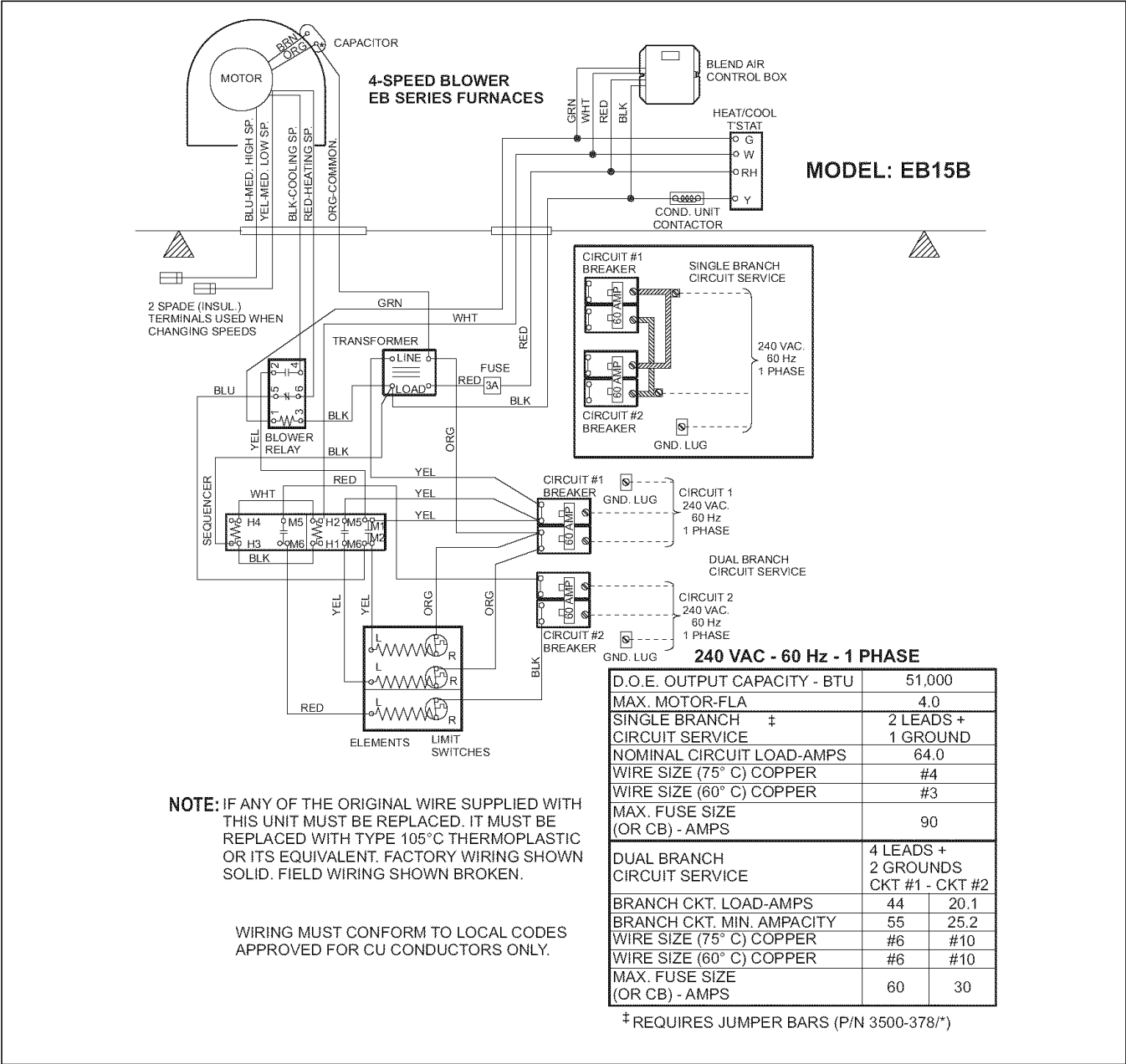

FIGURE 19 : EB15B WIRING DIAGRAM

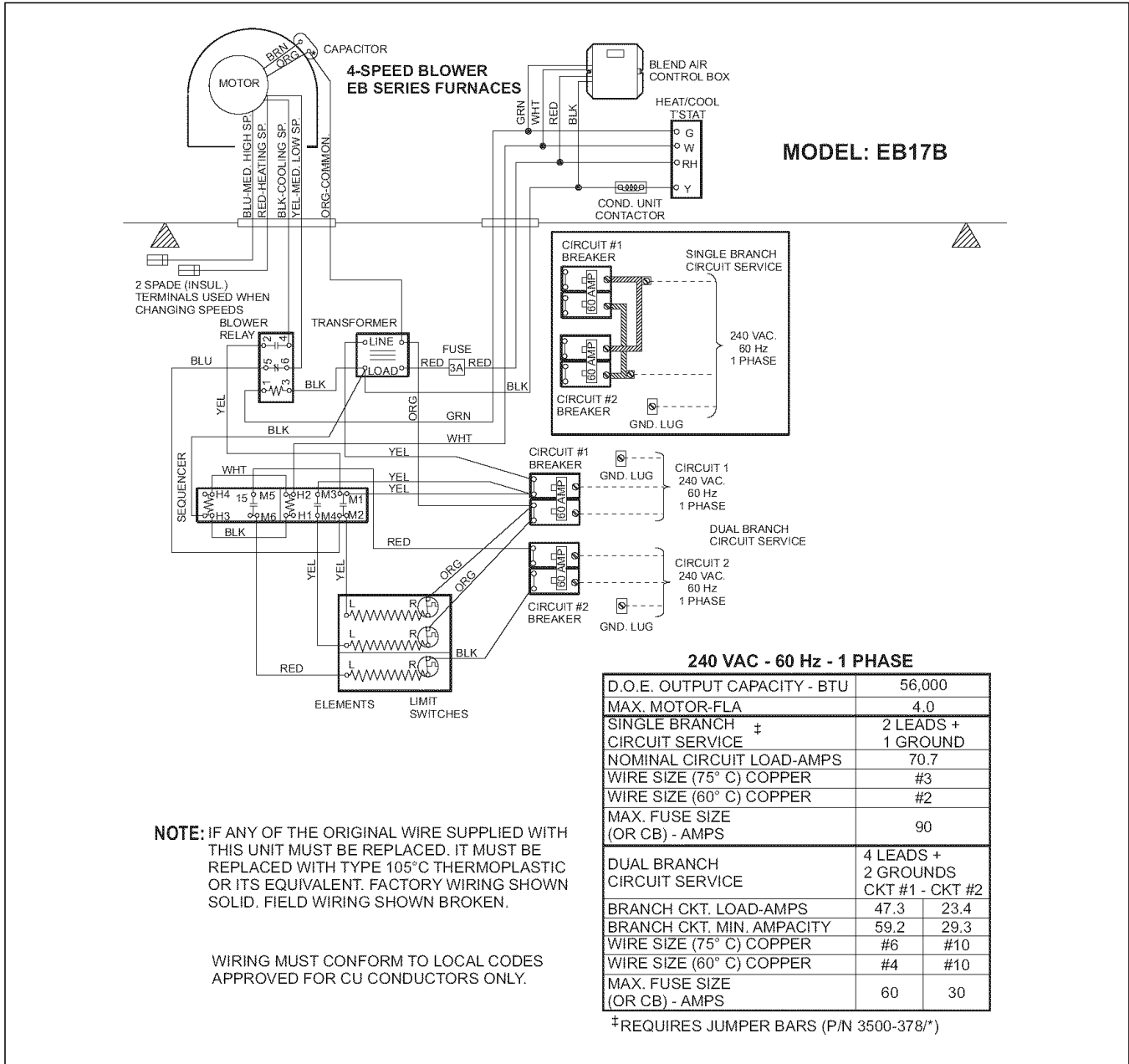

FIGURE 20 : EB17B WIRING DIAGRAM

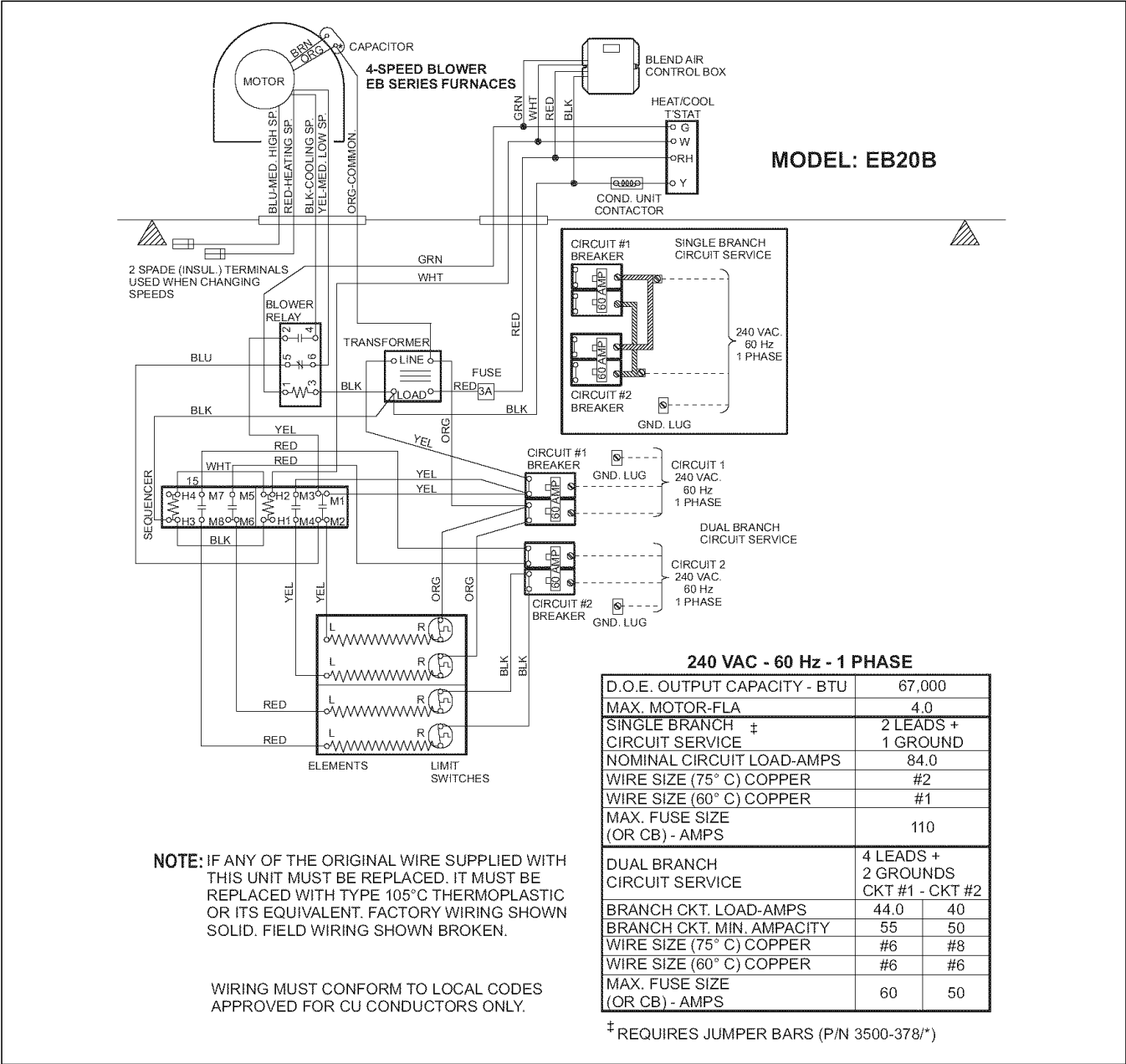

FIGURE 21 : EB20B WIRING DIAGRAM

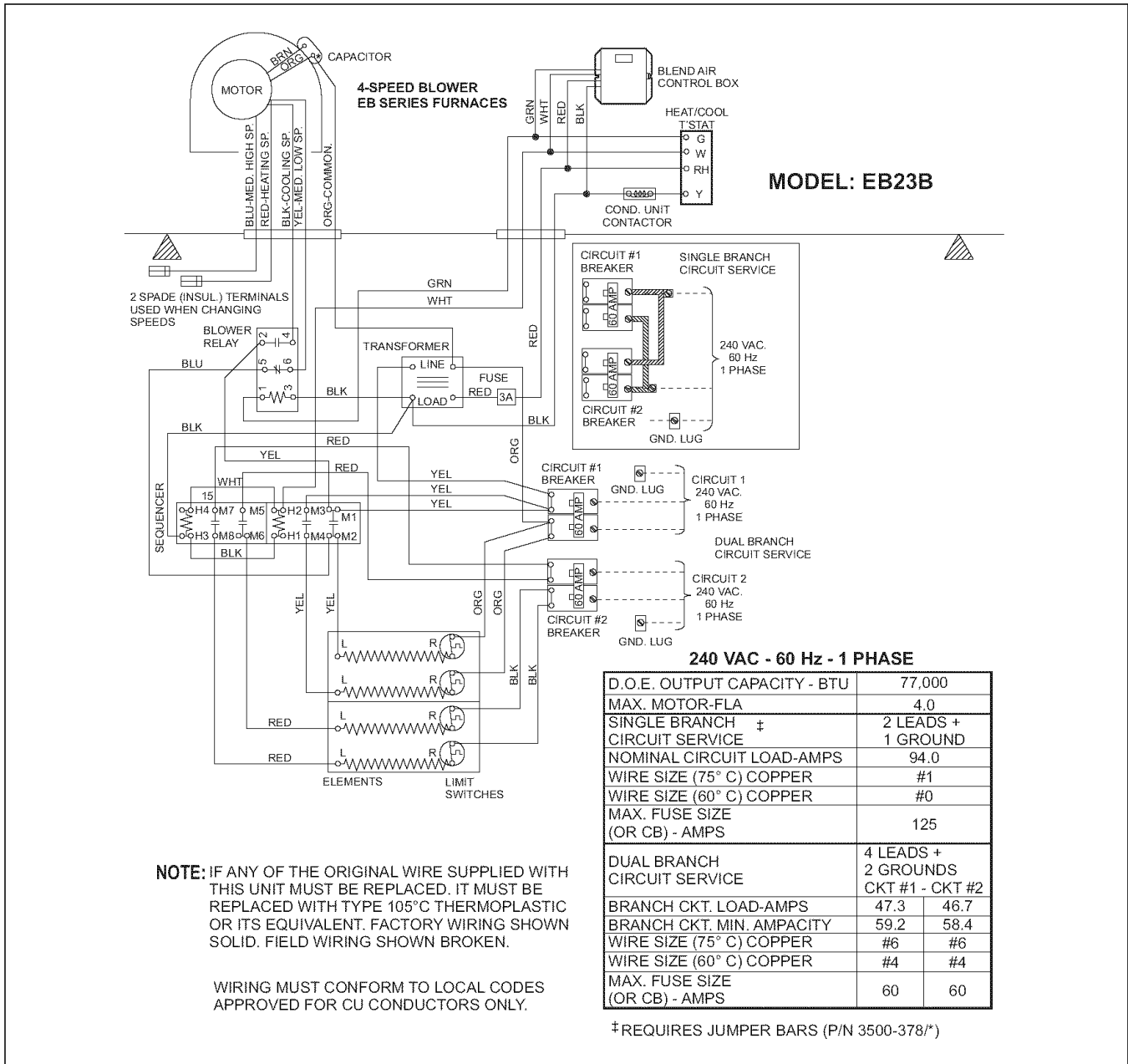
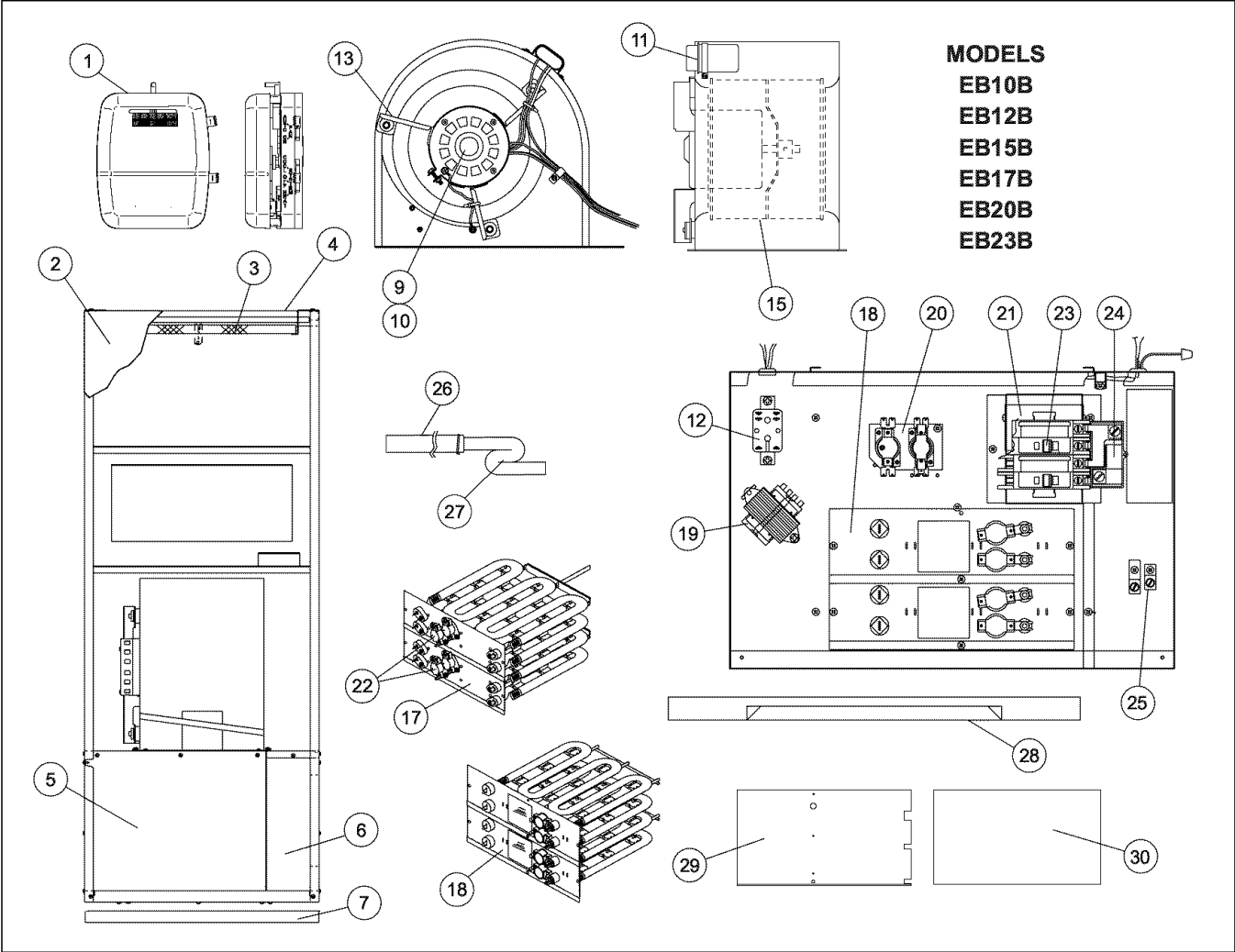

FIGURE 22 : EB23B WIRING DIAGRAM

REPAIR PARTS LIST



ITEM	DESCRIPTION	EB10B	EB12B	EB15B
1	Thermostat (Heat/Cool)	025-38746-000	025-38746-000	025-38746-000
2	Front Panel	3500-1751/B	3500-1751/B	3500-1751/B
	Front Panel (Front Return 4-Ton)	3500-1581	3500-1581	3500-1581
	Front Panel (Front Return 5-Ton)	3500-1591	3500-1591	3500-1591
3	Filter (16 x 20 x 1)	1214-2511	1214-2511	1214-2511
	Filter (20 x 20 x 1) (Front Return Panel)	1214-2521	1214-2521	1214-2521
4	Support Angle	3500-1861	3500-1861	3500-1861
5	Cover, Electric Box	3500-2351/A	3500-2361/A	3500-2361/A
6	Cover (Service Entrance)	3500-1271	3500-1271	3500-1271
7	Sub-base (Optional)	3500-1071/B	3500-1071/B	3500-1071/B
8*	Sub-base (M10) (Optional)	3500-5221	3500-5221	3500-5221
9	Blower Motor (For furnaces produced before 2/99)	1468-243P/A	1468-243P/A	1468-243P/A
10	Blower Motor (For furnaces produced after 2/99)	024-27651-000	024-27651-000	024-27651-000
11	Capacitor (7.5MFD/370V)	1499-4461	1499-4461	1499-4461
12	Relay	3110-3301	3110-3301	3110-3301
13	Motor Mount Assembly (1PC) (Kit)	373-19831-001	373-19831-001	373-19831-001
14				
15	Blower Wheel	1472-2831	1472-2831	1472-2831
16*	Limit Baffle (For furnaces produced before 3/98)	3500-129	3500-101	3500-101
17	Heater Element (For furnaces produced before 3/98)	(9.6Kw) 3500-4101	(11.2Kw) 3500-4121	(4.8Kw) & (9.6Kw) 3500-4051 & 3500-4101
18	Heater Element (See Note 3)	(9.6Kw) 3500-410P/A	(11.2Kw) 3500-412P/A	(4.8Kw) & (9.6Kw) 3500-405P/A & 3500-410P/A
19	Transformer (240/24V-40A)	3300-3861	3300-3861	3300-3861
20	Sequencer	3110-3571	3110-3571	3110-3571
21	Bracket (Circuit Breaker)	3500-128	3500-128	3500-128
22	Limit Switch (For furnaces produced before 3/98)	2 ea. 7142-3091 (Open 150, Close 110)	2 ea. 3500-3121 (Open 150, Close 120)	3 ea. 3500-3151/A (Open 150, Close 110)
23	Circuit Breaker (1 Req'd)	3500-377P/A	---	---
	Circuit Breaker (2 Req'd)	---	3500-377P/A	3500-377P/A
24	Buss Bar (See Note 2)	3500-378P	3500-378P	3500-378P
25	Ground Lug (Large)	1216-231	1216-231	1216-231
	Ground Lug (Small)	---	---	1216-229
26	Drain Tube (See Note 1)	029-22184-001	029-22184-001	029-22184-001
27	Condensate Trap (See Note 1)	3240-3051	3240-3051	3240-3051
28	Coil Shelf (See Note 1)	3500-174	3500-174	3500-174
29	Coil Shelf Panel (See Note 1)	3500-171	3500-171	3500-171
30	Insulation, Cover Panel (See Note 1)	010-69111-001	010-69111-001	010-69111-001
31*				
32*				
33*				
34*				
35*	Wiring diagram	035-15274-001	035-15275-001	035-15276-001
36*	Fuse	025-32746-026	025-32746-026	025-32746-026

NOTE: *Not Shown

Major components and suggested stocking items are shown with shaded item number.

--- Not applicable to specified model.

All parts with three digit suffix numbers are "Special Order" parts. These parts are subject to factory availability and require extra time for delivery.

1 Not Standard with furnace, contained in accessory kit no. 3500-8941.

2 Standard on EB12B.

ITEM	DESCRIPTION	EB17B	EB20B	EB23B
1	Thermostat (Heat/Cool)	025-38746-000	025-38746-000	025-38746-000
2	Front Panel Front Panel (Front Return 4-Ton) Front Panel (Front Return 5-Ton)	3500-1751/B 3500-1581 3500-1591	3500-1751/B 3500-1581 3500-1591	3500-1751/B 3500-1581 3500-1591
3	Filter (16 x 20 x 1) Filter (20 x 20 x 1) (Front Return Panel)	1214-2511 1214-2521	1214-2511 1214-2521	1214-2511 1214-2521
4	Support Angle	3500-1861	3500-1861	3500-1861
5	Cover, Electric Box	3500-2361/A	3500-2361/A	3500-2361/A
6	Cover (Service Entrance)	3500-1271	3500-1271	3500-1271
7	Sub-base (Optional)	3500-1071/B	3500-1071/B	3500-1071/B
8	Sub-base (M10) (Optional)	3500-5221	3500-5221	3500-5221
9	Blower Motor (For furnaces produced before 2/99)	1468-243P/A	1468-243P/A	1468-243P/A
10	Blower Motor (For furnaces produced after 2/99)	024-27651-000	024-27651-000	024-27651-000
11	Capacitor (7.5MFD/370V)	1499-4461	1499-4461	1499-4461
12	Relay	3110-3301	3110-3301	3110-3301
13	Motor Mount Assembly (1PC) (Kit)	373-19831-001	373-19831-001	373-19831-001
14				
15	Blower Wheel	1472-2831	1472-2831	1472-2831
16	Limit Baffle (For furnaces produced before 3/98)	3500-129	3500-129	3500-129
17	Heater Element (For furnaces produced before 3/98)	(4.8Kw) & (11.2Kw) 3500-4051 & 3500-4121	2 Ea. (9.6Kw) 3500-4101	(10.4Kw) & (11.2Kw) 3500-4111 & 3500-4121
18	Heater Element (See Note 3)	(5.6Kw) & (10.4Kw) 3500-406P/A & 3500-411P/A	2 Ea. (9.6Kw) 3500-410P/A	(10.4Kw) & (11.2Kw) 3500-411P/A & 3500-412P/A
19	Transformer (240/24V-40A)	3300-3861	3300-3861	3300-3861
20	Sequencer	3115-3571	3120A3571	3120A3571
21	Bracket (Circuit Breaker)	3500-128	3500-128	3500-128
22	Limit Switch (For furnaces produced before 3/98)	3 ea. 7142-3091 (Open 150, Close 110)	4 ea. 7142-3091 (Open 150, Close 110)	4 ea. 7142-3091 (Open 150, Close 110)
23	Circuit Breaker (2 Req'd) (See Note 2)	3500-377P/A	3500-377P/A	3500-377P/A
24	Buss Bar	3500-378P	3500-378P	3500-378P
25	Ground Lug (Large) Ground Lug (Small)	1216-231 1216-229	1216-231 1216-229	1216-231 1216-229
26	Drain Tube (See Note 1)	029-22184-001	029-22184-001	029-22184-001
27	Condensate Trap (See Note 1)	3240-3051	3240-3051	3240-3051
28	Coil Shelf (See Note 1)	3500-174	3500-174	3500-174
29	Coil Shelf Panel (See Note 1)	3500-1711	3500-1711	3500-1711
30	Insulation, Cover Panel (See Note 1)	010-69111-001	010-69111-001	010-69111-001
31*				
32*				
33*				
348				
35*	Wiring diagram	035-15277-001	035-15278-001	035-15279-001
36*	Fuse	025-32746-026	025-32746-026	025-32746-026

NOTE: *Not Shown

Major components and suggested stocking items are shown with shaded item number.

--- Not applicable to specified model.

All parts with three digit suffix numbers are "Special Order" parts. These parts are subject to factory availability and require extra time for delivery.

1 Not Standard with furnace, contained in accessory kit no. 3500-8941.

2 Standard on EB12B.

FIELD FIX KIT FOR EB12 (A&B) MANUFACTURED PRIOR TO AUGUST 1995		
FIELD FIX KT 3500-7121 CONTAINS:		
ITEM	DESCRIPTION	PART NO.
31*	1 Each Limit Baffle	3500-101
32*	2 Each Llimit Switch	3500-3121

FIELD FIX KIT FOR EB15 (A&B) MANUFACTURED PRIOR TO AUGUST 1995		
FIELD FIX KT 3500-7151 CONTAINS:		
ITEM	DESCRIPTION	PART NO.
33*	1 Each Limit Baffle	3500-101
34*	2 Each Llimit Switch	3500-3151/A