

INSTALLATION MANUAL

R-22 OUTDOOR SPLIT-SYSTEM AIR CONDITIONING

MODELS: 13 SEER - ERCQ SERIES
2 TO 4 TONS



Certification applies only
when the complete
system is listed
with ARI.



ISO 9001
Certified Quality
Management System

LIST OF SECTIONS

GENERAL	1	ELECTRICAL CONNECTIONS	5
SAFETY	1	INDICATIONS OF PROPER OPERATION	6
UNIT INSTALLATION	2		

LIST OF FIGURES

Typical Installation	2	Quick Connect Refrigerant Line	4
Oil Trap	3	Quick Connect Coupling	4
Minimum Suction Line Form	3	Outdoor Unit Control Box	5
Excess Tube	3	Typical Furnace Thermostat Wiring	5
Installation of Vapor Line	4	Typical Field Wiring (Air Handler / Electrical Heat)	6

LIST OF TABLES

Application Limitations	2
-------------------------------	---

SECTION I: GENERAL

These outdoor condensing units are designed to be connected to a matching UPG indoor coil. They are equipped with a filter-drier located in the liquid line.

Units with quick-connect coupling connections are factory charged with refrigerant to be matched with the appropriate precharged line set, and UPG indoor coil.

The outdoor unit is designed to be placed near the perimeter of the home, typically alongside or at the back of the home, remote from the indoor coil. The outdoor unit has been factory run-tested and all components of the system are ready for easy, immediate installation.

SECTION II: SAFETY



This is a safety alert symbol. When you see this symbol on labels or in manuals, be alert to the potential for personal injury.

Understand and pay particular attention to the signal words **DANGER**, **WARNING**, or **CAUTION**.

DANGER indicates an **imminently** hazardous situation, which, if not avoided, **will result in death or serious injury**.

WARNING indicates a **potentially** hazardous situation, which, if not avoided, **could result in death or serious injury**.

CAUTION indicates a potentially hazardous situation, which, if not avoided **may result in minor or moderate injury**. It is also used to alert against unsafe practices and hazards involving only property damage

WARNING

Improper installation may create a condition where the operation of the product could cause personal injury or property damage. Improper installation, adjustment, alteration, service or maintenance can cause injury or property damage. Refer to this manual for assistance or for additional information, consult a qualified contractor, installer or service agency.

CAUTION

This product must be installed in strict compliance with the enclosed installation instructions and any applicable local, state, and national codes including, but not limited to building, electrical, and mechanical codes.

INSPECTION

As soon as a unit is received, it should be inspected for possible damage during transit. If damage is evident, the extent of the damage should be noted on the carrier's delivery receipt. A separate request for inspection by the carrier's agent should be made in writing. See Local Distributor for more information.

LIMITATIONS

The unit should be installed in accordance with all National, State and Local Safety Codes and the limitations listed below:

1. Limitations for the indoor unit, coil, and appropriate accessories must also be observed.
2. The outdoor unit must not be installed with any duct work in the air stream. The outdoor fan is the propeller type and is not designed to operate against any additional external static pressure.

- The maximum and minimum conditions for operation must be observed to assure a system that will give maximum performance with minimum service.

TABLE 1: Application Limitations

Ambient Air Temperature on Outdoor Coil		Air Temperature on Indoor Coil	
Min. DB	Max. DB	Min. WB	Max. WB
50 °F	115 °F	57 °F	72 °F

- The unit should not be operated at outdoor temperatures below 50° F without an approved low ambient operation accessory kit installed.

SECTION III: UNIT INSTALLATION

LOCATION

Before starting the installation, select and check the suitability of the location for both the indoor and outdoor unit. Observe all limitations and clearance requirements.

The outdoor unit must have sufficient clearance for air entrance to the condenser coil, air discharge, and service access. See Figure 1.

NOTE: For multiple unit installations, units must be spaced a minimum of 18 inches apart (coil face to coil face).

If the unit is to be installed on a hot sun exposed roof or a black-topped ground area, the unit should be raised sufficiently above the roof or ground to avoid taking the accumulated layer of hot air into the outdoor unit.

Provide an adequate structural support.

ADD-ON REPLACEMENT/RETROFIT

The following steps should be performed in order to insure proper system operation and performance.

- Change-out the indoor coil, if required, to an approved R-22 coil/condensing unit combination with the appropriate metering device.
- If the outdoor unit is being replaced due to a compressor burnout, then installation of a 100% activated alumina suction-line filter drier in the suction-line is required, in addition to the factory installed liquid-line drier. Operate the system for 10 hours. Monitor the suction drier pressure drop. If the pressure drop exceeds 3 psig, replace both the suction-line and liquid-line driers. After a total of 10 hours run time where the suction-line pressure drop has not exceeded 3 psig, replace the liquid line drier, and remove the suction-line drier. Never leave a suction-line drier in the system longer than 50 hours of run time.

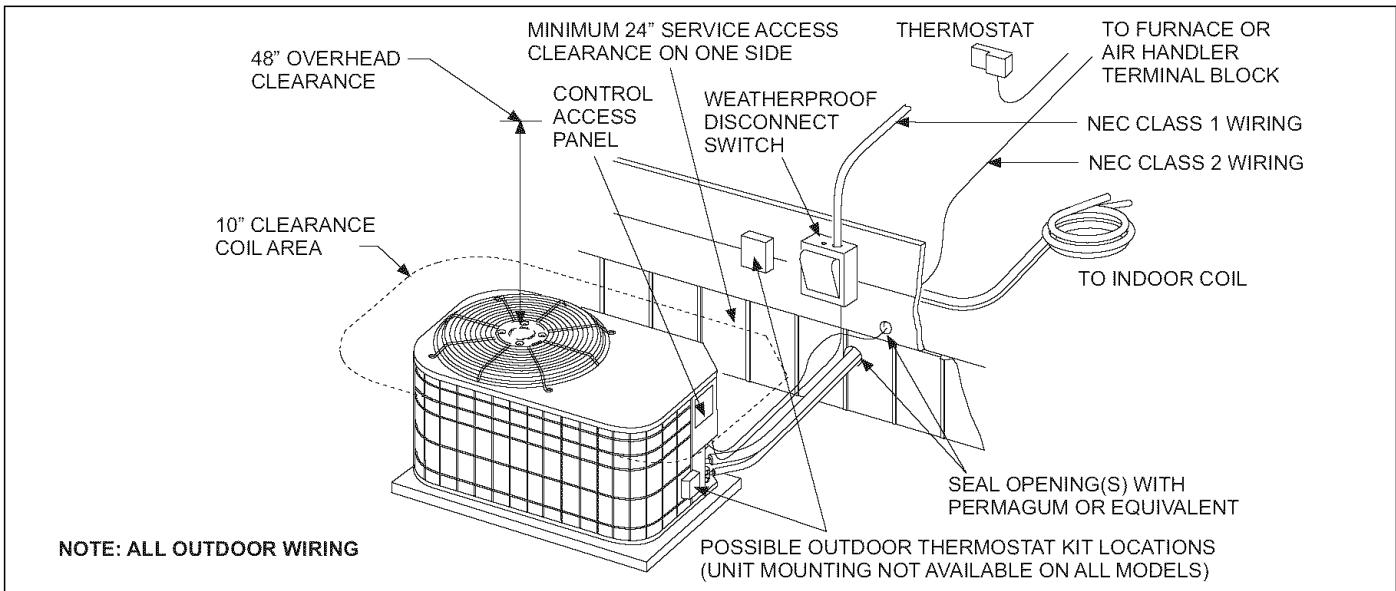

FIGURE 1: Typical Installation

GROUND INSTALLATION

The unit should be installed on a solid base that is 2" above grade and will not shift or settle, causing strain on the refrigerant lines and possible leaks. Maintain the clearances shown in Figure 1 and install the unit in a level position. The base pad should not come in contact with the foundation or side of the structure because sound may be transmitted to the residence.

The length of the refrigerant tubing between the outdoor unit and indoor coil should be as short as possible to avoid capacity and efficiency losses. Excessive spacing of the outdoor unit from the home can result in the refrigerant lines being restricted by trampling or being punctured by lawn mowers. Locate the outdoor unit away from bedroom windows or other rooms where sound might be objectionable.

Adverse effects of snow or sleet accumulating on the outdoor coil can be eliminated by placing the outdoor unit where the prevailing wind does not blow across the unit. Trees, shrubs, corners of buildings, and fences standing off from the coil can reduce capacity loss due to wind chill effect.

Provide ample clearance from shrubs to allow adequate air to pass across the outdoor coil without leaves or branches being pulled into the coil.

ROOF INSTALLATION

When installing units on a roof, the structure must be capable of supporting the total weight of the unit, including a pad, lintels, rails, etc., which should be used to minimize the transmission of sound or vibration into the conditioned space.

LIQUID LINE FILTER-DRIER

The air conditioning unit's copper spun filter/dryer is located on the liquid line.

NOTE: Replacements for the liquid line drier *must be exactly the same as marked on the original factory drier*. See Source 1 for O.E.M. replacement driers.

CAUTION

Failure to do so or using a substitute drier or a granular type may result in damage to the equipment.

PIPING CONNECTIONS

The outdoor condensing unit must be connected to the indoor evaporator coil using field supplied refrigerant grade (ACR) copper tubing that is internally clean and dry. Units should be installed only with the tubing sizes for approved system combinations as specified in tabular data sheet. The charge given is applicable for total tubing lengths up to 15 feet. See Application Data Part Number 036-61920-000 for installing tubing of longer lengths and elevation differences.

NOTE: Using a larger than specified line size could result in oil return problems. Using too small a line will result in loss of capacity and other problems caused by insufficient refrigerant flow. Slope horizontal vapor lines at least 1" every 20 feet toward the outdoor unit to facilitate proper oil return.

OIL TRAPPING

When the outdoor unit is above the indoor coil oil trapping is necessary. An oil trap should be provided for every 20 ft. of rise. See Figure 2.

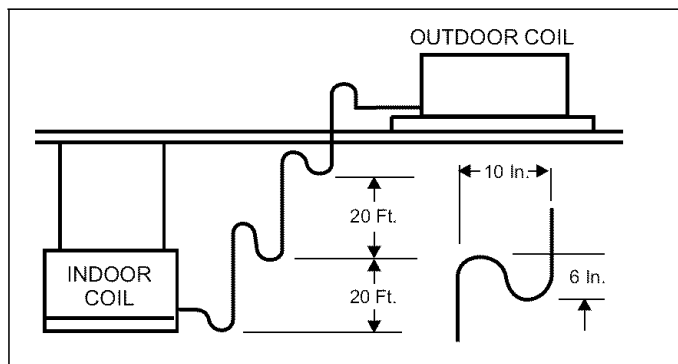

FIGURE 2: Oil Trap

REFRIGERANT LINE

IMPORTANT: Do not remove protective caps from couplings until pre-charged lines are routed and ready for final connection. Protective caps prevent dirt from entering couplings and contaminating system when connected together.

1. Check size and length of precharged refrigerant lines before installing.
 - a. Check the size of the precharged refrigerant lines to insure that they are correct for the model being installed.
 - b. Check the final routing of the tubing, and insure tubing will be of adequate length, with allowance for connection at the coil and outdoor unit.
2. Copper tubing will work-harden.
 - a. The precharged tubing should be handled carefully.
 - b. Do not bend or work the tubing any more than necessary. (The larger size tubing 3/4" for example, will work-harden rapidly as it is formed. As the tubing becomes harder, it is more susceptible to kinking and damage).

3. Forming Copper.
 - a. No attempt should be made to bend the suction line in a shorter radius than 12". See Figure 3.

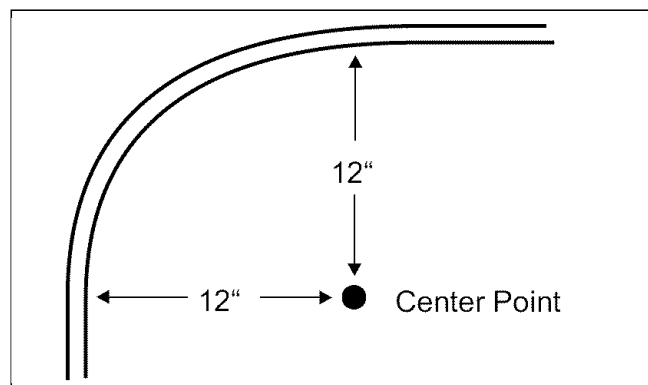

FIGURE 3: Minimum Suction Line Form

4. How to dispose of excess tubing.
 - a. Tubing may be longer than required. Coil excess tubing nearer the indoor coil rather than the outdoor unit.
 - b. Excess tubing must be coiled horizontally so the flow of refrigerant is from top to bottom of the coil and toward the outdoor unit. Another method is to form a horizontal "U" large enough to take care of excess. See Figure 4.

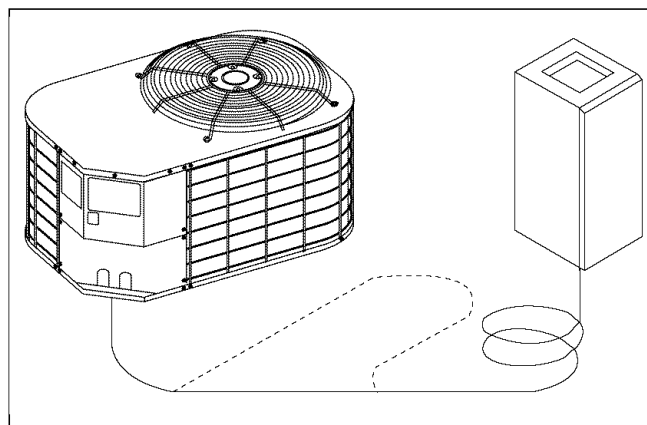

FIGURE 4: Excess Tube

5. Slope tubing toward outdoor unit.
 - a. When the coil is above the outdoor unit, the suction line should be sloped with a fall of at least 1/4" per feet toward the outdoor unit.
 - b. When the outdoor unit is above the coil, the tubing should be sloped downward along lateral distance to the bottom, or from the vertical riser.
 6. Insulation of suction line.
 - a. Standard suction lines come pre-insulated from the factory with 3/8" closed cell insulation, adequate for average installations.
- NOTE:** In regions of extreme temperatures and humidity, additional insulation may be required to prevent excessive condensation and serious loss of capacity.
- b. Do not insulate liquid and suction lines together.
 - c. Liquid lines should not be insulated.
 - d. Liquid lines should not be in bare contact with suction line. See Figure 5.

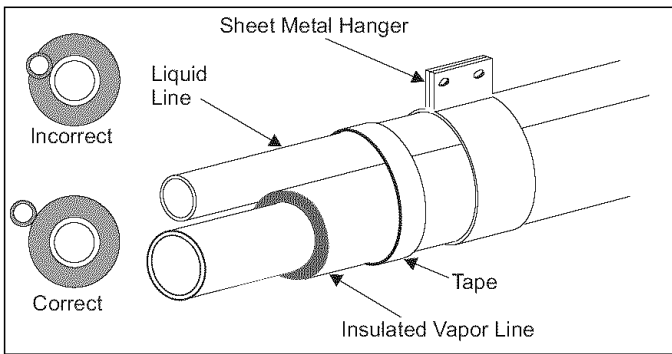

FIGURE 5: Installation of Vapor Line

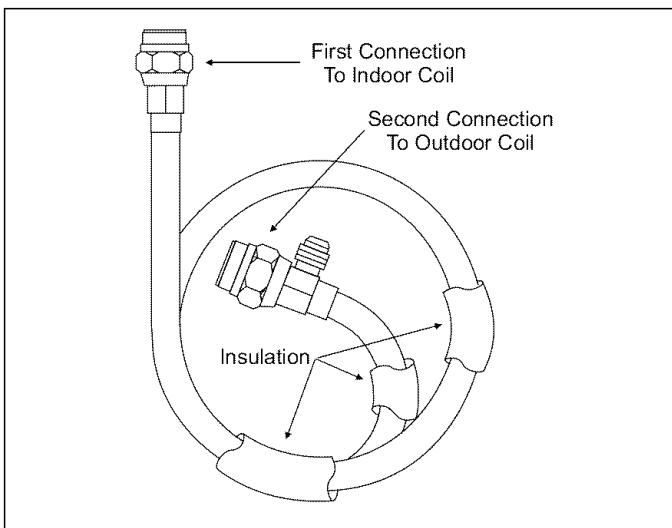

FIGURE 6: Quick Connect Refrigerant Line

▲ WARNING

Liquid refrigerant under pressure. Liquid refrigerant can cause severe frostbite. To avoid possible loss of sight and/or frostbite use eye protection (safety glasses or safety face shield). Wearing leather gloves will offer protection to hands.

7. Install refrigerant lines to indoor coil first. (The couplings without Schrader valves are to be connected to the indoor coil. See Figure 6.
 - a. Form the tubing so it is properly aligned with the connections on the coil.
 - b. Remove plugs and caps from connections.
 - c. Check that the rubber seals in connection ends are intact.
 - d. Be sure surfaces are clean.
 - e. Lubricate the rubber seals with clean refrigerant oil and make connections.
 - f. Thread couplings together by hand to be sure they are not cross threaded. Tighten coupling so diaphragms are touching. (Do not puncture diaphragms at this time).
8. Install refrigerant line to outdoor unit. (The couplings with Schrader valves are to be connected to the outdoor unit.
 - a. Form the tubing so it is properly aligned with the connections on the outdoor unit. Insure the Schrader valves are accessible.

- b. Remove plugs and caps from connections.
 - c. Check that the rubber seals in connection ends are intact.
 - d. Be sure surfaces are clean.
 - e. Lubricate the rubber seals with clean refrigerant oil and make connections.
 - f. Thread couplings together by hand to be sure they are not cross threaded. Tighten coupling so diaphragms are touching. (Do not puncture diaphragms at this time).
9. Tightening couplings.
 - a. Tighten indoor coil couplings with wrenches; using wrench on stationary fitting of coupling and liquid line fitting at coil while nut is being tightened. See Figure 7. Tighten the nut until the coupling bottoms out.
 - b. Then tighten an additional 1/6 turn to complete the knife edge seal.
 - c. Tighten outdoor unit couplings, with wrenches using a wrench on the stationary fitting of the coupling while nut is being tightened. Tighten the nut until the coupling bottoms out.
 - d. Then tighten an additional 1/6 turn to complete the knife edge seal.

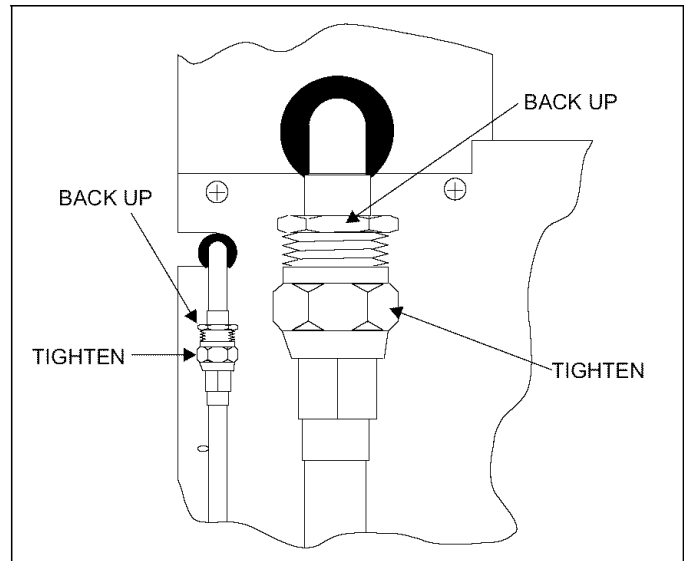

FIGURE 7: Quick Connect Coupling

10. Check for leaks.
 - a. After the line set connections have been made they should be checked for leaks.
 - b. If the valves were kept clean and lubricated per instruction no leaks should be found.
 - c. Use leak detect solution or soap solution for leak testing. An electronic leak detector is recommended.

▲ CAUTION

IT IS UNLAWFUL TO KNOWINGLY VENT, RELEASE OR DISCHARGE REFRIGERANT INTO THE OPEN AIR DURING REPAIR, SERVICE, MAINTENANCE OR THE FINAL DISPOSAL OF THIS UNIT.

WHEN THE SYSTEM IS FUNCTIONING PROPERLY AND THE OWNER HAS BEEN FULLY INSTRUCTED, SECURE THE OWNER'S APPROVAL.

SECTION IV: ELECTRICAL CONNECTIONS

GENERAL INFORMATION & GROUNDING

Check the electrical supply to be sure that it meets the values specified on the unit nameplate and wiring label.

Power wiring, control (low voltage) wiring, disconnect switches and over current protection must be supplied by the installer. Wire size should be sized per NEC requirements.

CAUTION

All field wiring must USE COPPER CONDUCTORS ONLY and be in accordance with Local, National, Fire, Safety & Electrical Codes. This unit must be grounded with a separate ground wire in accordance with the above codes.

The complete connection diagram and schematic wiring label is located on the inside surface of the unit service access panel.

FIELD CONNECTIONS POWER WIRING

1. Install the proper size weatherproof disconnect switch outdoors and within sight of the unit.
2. Remove the screws at the top and sides of the corner cover. Slide corner cover down and remove from unit.
3. Run power wiring from the disconnect switch to the unit.
4. Route wires from disconnect through power wiring opening provided and into the unit control box as shown in Figure 8.
5. Install the proper size time-delay fuses or circuit breaker, and make the power supply connections.

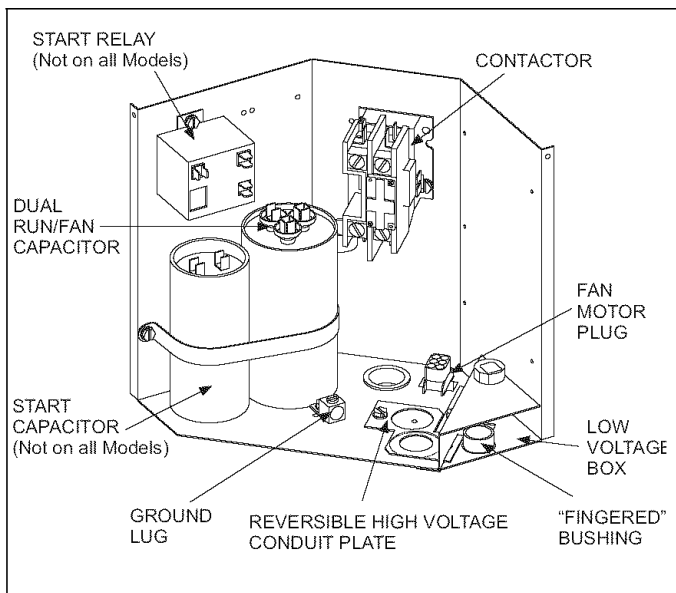

FIGURE 8: Outdoor Unit Control Box

FIELD CONNECTIONS CONTROL WIRING

1. Route low voltage wiring into bottom of control box as shown in Figure 8. Make low voltage wiring connections inside the low voltage box per Figures 9 & 10.
2. The complete connection diagram and schematic wiring label is located on the inside surface of the unit service access panel.
3. Replace the corner cover removed in Step 2.
4. All field wiring to be in accordance with national electrical codes (NEC) and/or local-city codes.

NOTE: A Start Assist Kit is available and recommended for long line set applications or in areas of known low voltage problems.

5. Mount the thermostat about 5 ft. above the floor, where it will be exposed to normal room air circulation. Do not place it on an outside wall or where it is exposed to the radiant effect from exposed glass or appliances, drafts from outside doors or supply air grilles.
6. Route the 24-volt control wiring (NEC Class 2) from the outdoor unit to the indoor unit and thermostat.

NOTE: To eliminate erratic operation, seal the hole in the wall at the thermostat with permagum or equivalent to prevent air drafts affecting the operation of in the thermostat.

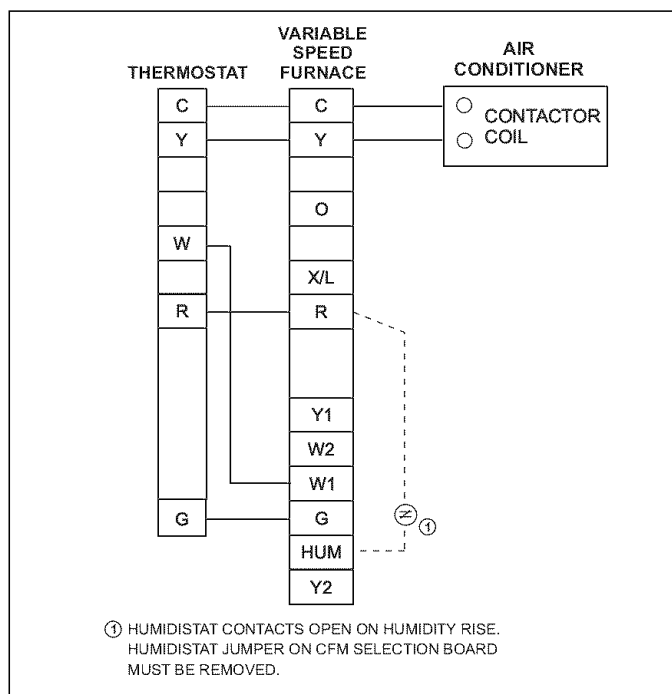

FIGURE 9: Typical Furnace Thermostat Wiring

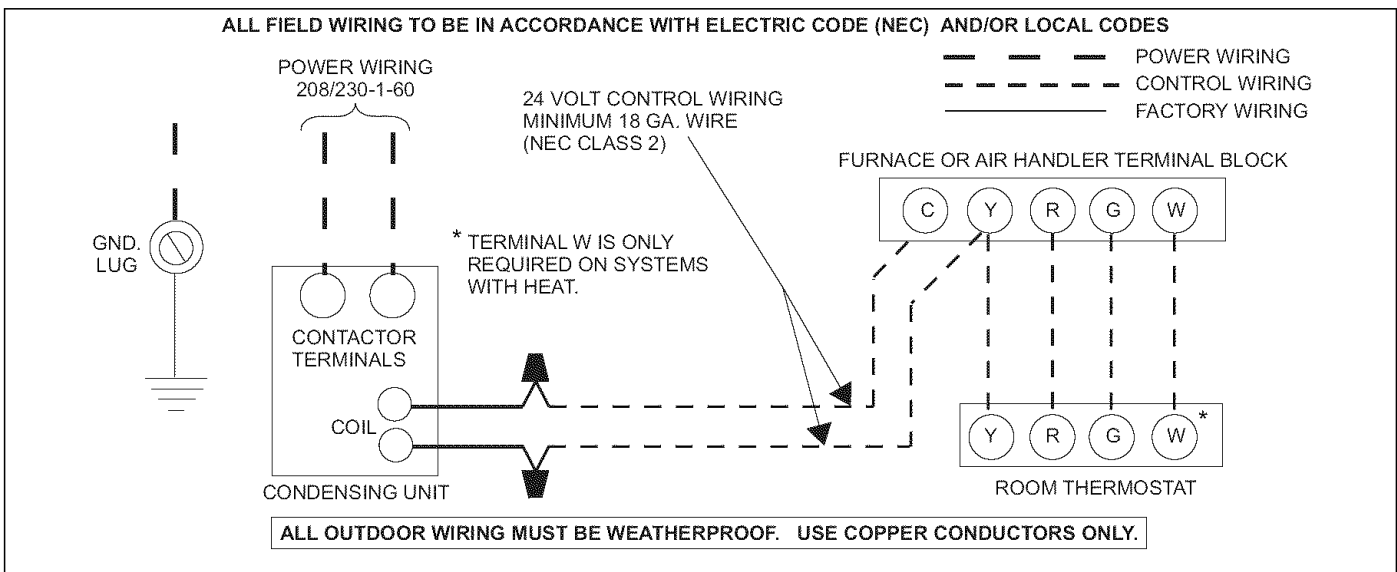

FIGURE 10: Typical Field Wiring (Air Handler / Electrical Heat)

SECTION V: INDICATIONS OF PROPER OPERATION

COOLING

1. The outdoor fan should be running, with warm air being discharged from the top of the unit.
2. The indoor blower (furnace or air handler) will be operating, discharging cool air from the ducts. Coils or other parts in the air circuit should be cleaned as often as necessary to keep the unit clean. Use a brush, vacuum cleaner attachment, or other suitable means.
3. The vapor line at the outdoor unit will feel cool to the touch.
4. The liquid line at the outdoor unit will feel warm to the touch.

INSTRUCTING THE OWNER

Assist owner with processing warranty cards. Review Owners Guide and provide a copy to the owner and guidance on proper operation and maintenance. Instruct the owner or the operator how to start, stop and adjust temperature setting.

When applicable, instruct the owner that the compressor is equipped with a crankcase heater to prevent the migration of refrigerant to the compressor during the "OFF" cycle. The heater is energized only when

the unit is not running. If the main switch is disconnected for long periods, do not attempt to start the unit until 8 hours after the switch has been connected. This will allow sufficient time for all liquid refrigerant to be driven out of the compressor.

The installer should also instruct the owner on proper operation and maintenance of all other system components.

MAINTENANCE

1. Dirt should not be allowed to accumulate on the outdoor coils or other parts in the air circuit. Clean as often as necessary to keep the unit clean. Use a brush, vacuum cleaner attachment, or other suitable means.
2. The outdoor fan motor is permanently lubricated and does not require periodic oiling.
3. If the coil needs to be cleaned, it should be washed with Calgon Coilclean (mix one part Coilclean to seven parts water). Allow solution to remain on coil for 30 minutes before rinsing with clean water. Solution should not be permitted to come in contact with painted surfaces.
4. Refer to the furnace or air handler instructions for filter and blower motor maintenance.
5. The indoor coil drain pan should be inspected and cleaned regularly to prevent odors and assure proper drainage.

NOTES

