



COUNTERFLOW WALL FURNACE



INSTALLATION AND OPERATING INSTRUCTIONS

P/N 78111
REV. 05/03



MODEL NUMBERS

24 VOLT SYSTEM WITH LOW-BTU PILOT	NATURAL GAS	CF353C-R	CF503C-R	CF653C-R
	L.P. GAS	CF354C-R	CF504R	CF654C-R

24 VOLT SYSTEM WITH INTERMITTENT IGNITION (I.I.D.)	NATURAL GAS	CF357C-R	CF557C-R
	L.P. GAS	CF358C-R	CF558C-R

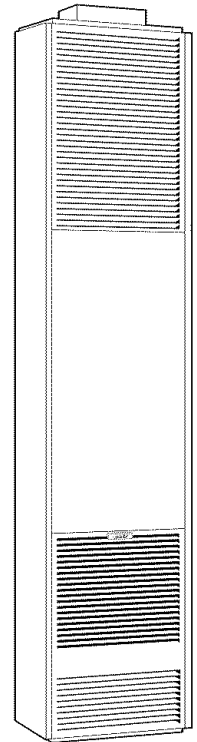

WARNING: If the information in this manual is not followed exactly, a fire or explosion may result causing property damage, personal injury or loss of life.

- Do not store or use gasoline or other flammable vapors and liquids in the vicinity of this or any other appliance.

WHAT TO DO IF YOU SMELL GAS:

- Do not try to light any appliance.
- Do not touch any electrical switch; do not use any phone in your building.
- Immediately call your gas supplier from a neighbor's phone. Follow the gas supplier's instructions.
- If you cannot reach your gas supplier, call the fire department.

- **INSTALLATION AND SERVICE MUST BE PERFORMED BY A QUALIFIED INSTALLER, SERVICE AGENCY OR THE GAS SUPPLIER.**

This appliance is equipped with a blocked flue switch designed to protect against improper venting of combustion products.

THIS UNIT IS NOT TO BE INSTALLED IN MOBILE HOMES.

WARNING: Operation of this furnace when not connected to a properly installed and maintained venting system can result in Carbon Monoxide (C.O.) poisoning and possible death. For your safety, this furnace and the venting system should be inspected at least annually by a qualified service person.

The coating selected to provide longer life to the heat exchanger may smoke slightly upon initial firing. Please provide adequate ventilation if this occurs.

This unit is not approved for installation in mobile homes, greenhouses, or environments involving dusty, wet, corrosive, or explosive conditions. Such conditions will invalidate the warranty and may create unsafe conditions.

CONTENTS

Contents.....	2	Lighting & Re-Lighting Instructions.....	10,11
Introduction.....	2	Operation.....	12
Specifications.....	2	Terminal Block Wiring Diagram.....	13
Safety Rules.....	3	Manual Reset.....	13
Helpful Installation Information.....	3	Maintenance Instructions.....	13
Connecting the Vent.....	3,4	Wiring Diagram.....	14,15
Combustion and Ventilation Air.....	5	Side & Rear Discharge Kits.....	16,17
Furnace Location.....	6	Trouble Shooting Chart.....	18,19
Rough-In Instructions.....	6,7	Repair Parts (break down).....	20-24
Installation.....	8	Repair Parts List.....	21-25
Controls.....	9	Warranty.....	27
Pilot Flame Adjustment.....	9		

INSTALLER MUST LEAVE THESE INSTRUCTIONS WITH THE CONSUMER, HAVE THEM COMPLETE, AND RETURN THE WARRANTY CARD.

INTRODUCTION

THIS IS A GAS-FIRED, GRAVITY VENTED WALL FURNACE THAT WILL OPERATE SAFELY AND PROVIDE AN EFFICIENT SOURCE OF HEAT WHEN INSTALLED, OPERATED AND MAINTAINED AS RECOMMENDED IN THESE INSTALLATION AND OPERATING INSTRUCTIONS. READ THESE INSTRUCTIONS THOROUGHLY BEFORE INSTALLING, SERVICING, OR USING THE APPLIANCE. IF YOU DO NOT UNDERSTAND ANY PART OF THESE INSTRUCTIONS CONSULT LOCAL AUTHORITIES, OTHER QUALIFIED INSTALLERS, SERVICE AGENCIES, THE GAS SUPPLIER, OR THE MANUFACTURER.

COUNTERFLOW WALL FURNACE SPECIFICATIONS

Your counterflow wall furnace is packed in a single carton that also includes thermostat, thermostat wire, and insulated staples. The thermostat, wire, and staples are packed in the burner compartment and are accessible by removing the burner access door. While the burner access door is open, check the rating plate to verify that the model number is correct and that the wall furnace is equipped for the type gas you intend to use.

Model Number	Type Control	Type Gas	BTU/HR. Input	Vent Size (Oval)	Gas Inlet	Finished Dimensions	Blower Speed	Amps	CFM	Approx. Shipping Weight
<u>MODELS WITH LOW-BTU STANDING PILOT</u>										
CF353C	24 Volt	Nat.	35,000	4"	½"	14-5/16"Wx10¼"Dx78-5/8"H	1	1.95	320	95 Lbs.
CF354C	24 Volt	L.P.	35,000	4"	½"	14-5/16"Wx10¼"Dx78-5/8"H	1	1.95	320	95 Lbs.
CF503C	24 Volt	Nat.	50,000	4"	½"	14-5/16"Wx10¼"Dx81-5/16"H	2	2.25	440	104 Lbs.
CF504C	24 Volt	L.P.	50,000	4"	½"	14-5/16"Wx10¼"Dx81-5/16"H	2	2.25	440	104 Lbs.
CF653C	24 Volt	Nat.	65,000	4"	½"	14-5/16"Wx10¼"Dx87-5/16"H	2	2.25	440	107 Lbs.
CF654C	24 Volt	L.P.	65,000	4"	½"	14-5/16"Wx10¼"Dx87-5/16"H	2	2.25	440	107 lbs.
<u>MODELS WITH INTERMITTENT IGNITION</u>										
CF357C	24 Volt	Nat.	35,000	4"	½"	14-5/16"Wx10¼"Dx78-5/8"H	1	2.2	320	95 Lbs.
CF358C	24 Volt	L.P.	35,000	4"	½"	14-5/16"Wx10¼"Dx78-5/8"H	1	2.25	320	95 Lbs.
CF557C	24 Volt	Nat.	55,000	4"	½"	14-5/16"Wx10¼"Dx87-5/16"H	2	2.5	440	107 Lbs.
CF558C	24 Volt	L.P.	55,000	4"	½"	14-5/16"Wx10¼"Dx87-5/16"H	2	2.55	440	107 Lbs.

SAFETY RULES

1. Improper installation, adjustment, alteration, service or maintenance can cause property damage, bodily injury or death. If you do not understand these instructions or your local codes, call local authorities, a qualified installer, service agency, gas supplier, or the manufacturer.
2. Do not install this fan type wall furnace in a recreational vehicle trailer or mobile home.
3. Do not operate this fan type wall furnace unless it is connected to a properly installed and maintained vent system. Do not exhaust flue gases into the room, wall or attic space for any reason.
4. Locate the thermostat in a room or space that cannot be separated by a door or other means from the room or space in which the front outlet grill is installed.
5. Adequate air for combustion and venting must be provided.
6. If rising water may enter the wall furnace, turn off the gas immediately and disconnect the electric service. Do not use the wall furnace if any part has been under water. Immediately call a qualified service technician to inspect the wall furnace and to replace any part of the control system or any gas control which has been under water.
7. Have your fan type wall furnace and vent system inspected at least annually by a qualified service agency.
8. Before cleaning or servicing the wall furnace, turn off the gas and allow it to cool. This will prevent burns.
9. Due to high temperatures, the furnace should be located out of traffic and away from furniture and draperies.
10. Children and adults should be alerted to the hazards of high surface temperatures and should stay away to avoid burns or clothing ignition.
11. Young children should be carefully supervised when they are in the same room as the furnace.
12. Clothing or other flammable material should not be placed on or near the furnace.
13. Any safety screen guard or gill removed for servicing must be replaced prior to operating the furnace.
14. Locate the blocked flue switch and the auxiliary limit switch and push in the reset button. This will reset the switch in case it accidentally opened during shipping.

READ CAREFULLY BEFORE INSTALLING UNIT

These installation instructions are a general guide, and do not supersede applicable local codes and ordinances. Before planning or making the installation, be sure it complies with all phases of the local heating code. Or, in the absence of local codes, the latest edition of the National Fuel Gas Code, ANSI.Z223.1. In Canada, see latest edition of CAN1-B149.

The appliance, when installed must be electrically grounded in accordance with local codes or, in the absence of local codes, the latest edition of the National Electrical Code, ANSI/NFPA No. 70. In Canada, see latest edition of CSA C22.1.

The ANSI standards are available from the American Gas Association, 1515 Wilson Blvd., Arlington, Virginia 22209.

The NFPA standards are available from the National Fire Protection Association, Batterymarch Park, Quincy, MA. 02269. Canadian standards are available from International Approval Services, 178 Rexdale Blvd., Etobicoke, Ontario, Canada M9W 1R3.

VENTING

This appliance must be properly connected to a venting system. Consult local ordinances governing venting. Install only UL listed type BW 4" oval gas vent. When the vent enters the attic, a listed type B-1 round flue pipe may be used. See Figure 1, Page 4.

Vent pipe must connect to the wall furnace or header plate with a "B" vent base plate and terminate with a cap at a point at least 12 ft. above the bottom of the wall furnace and two feet above any obstacle within a 10 foot radius and at least 3 foot above the roof.

Provisions must be made for adequate combustion and ventilation air. This appliance must not be connected to a chimney flue serving a separate solid fuel burning appliance.

All type "B" vents shall extend in a generally vertical direction with offsets not exceeding 45 degrees, except that a vent system having not more than one 60 degree offset may be allowed.

Any angle greater than 45 degrees from the vertical is considered horizontal. The total horizontal run of a vent plus the horizontal vent connector shall be not greater than 75 percent of the vertical height of the vent. Any offsets used should be as far above the drafthood as possible to allow a venting action to begin before any restriction is encountered.

VENTING - CONTINUED

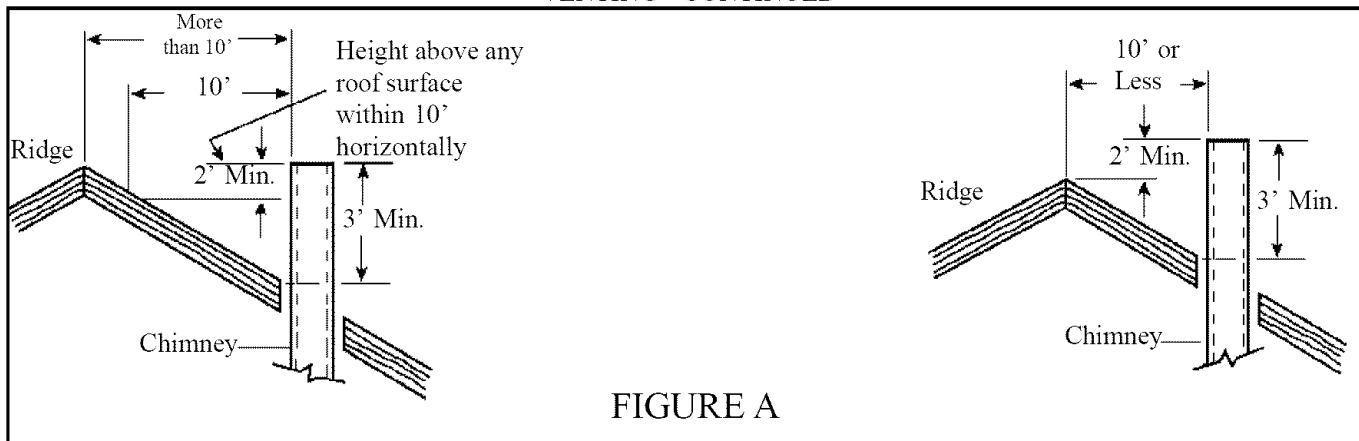

FIGURE A

This appliance is equipped with a blocked flue switch.

WARNING: Do not bypass the blocked flue switch. To do so could expose the consumer to property damage, personal injury or possible death.

This switch, when activated, will interrupt the electrical circuit between the transformer and the gas valve causing the main burner flame to extinguish. The main burner will not re-light until the blocked flue switch has been manually reset. To reset the switch, after locating it between the bottom of the fan shroud and the top of the draft diverter, simply push the red button on top of the switch. If the homeowner experiences this problem, then the vent system must be checked and corrected. NOTE: An existing vent that has worked for years may not be adequate for today's appliances because of higher efficiency requirements that result in lower stack temperatures.

WARNING: Operation of this wall furnace when not connected to a properly installed and maintained venting system or tampering with the blocked flue switch can result in Carbon Monoxide (CO) poisoning and possible death.

(SEE LIST OF POSSIBLE CAUSES AND CORRECTIONS ON PAGE 19).

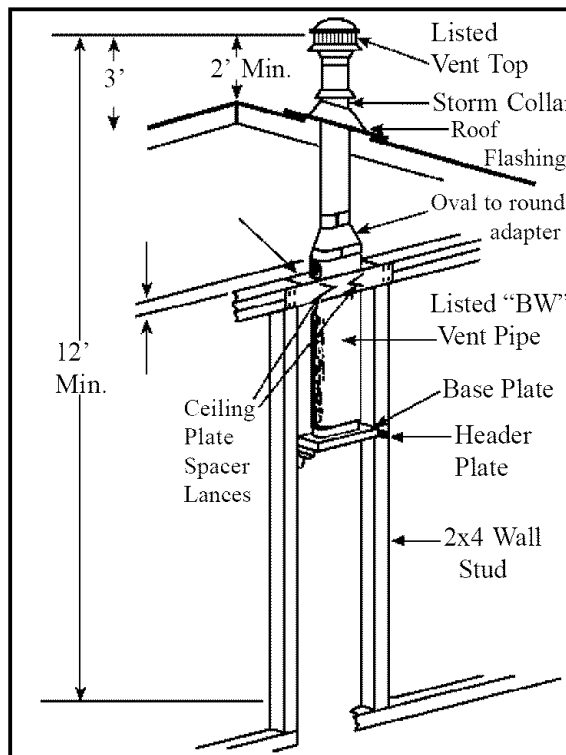
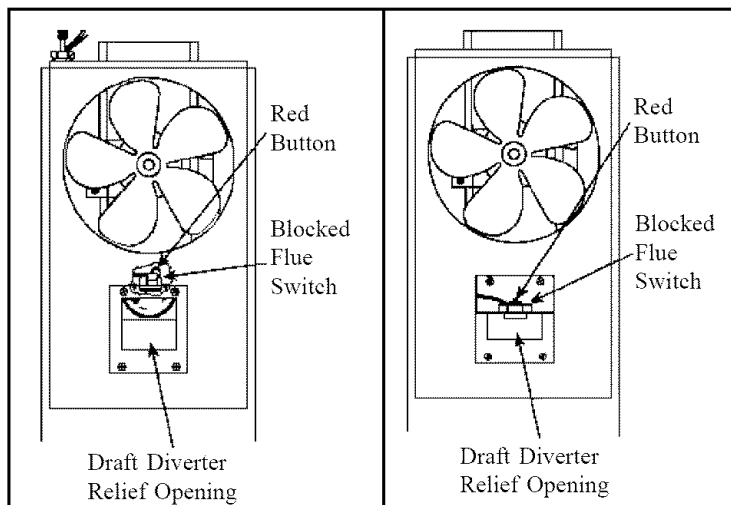

FIG. 1 - VENT INSTALLATION

All type "B" vents shall extend in a generally vertical direction with offsets not exceeding 45 degrees, except that a vent system having not more than one 60 degree offset may be allowed.

Any angle greater than 45 degrees from the vertical is considered horizontal. The total horizontal run of a vent plus the horizontal vent connector shall be not greater than 75 percent of the vertical height of the vent.

Any offsets used should be as far above the drafthood as possible to allow a venting action to begin before any restriction is encountered.



"CF35" Series Counterflow
Page 4

"CF50/55/65" Series Counterflow

COMBUSTION AND VENTILATION AIR

When installed, this gas appliance must be provided with fresh air for combustion, ventilation, and dilution of hot flue gases. The minimum required volume of the area where the appliance is installed should be 50 cubic feet per 1,000 btu/hr.

If installed in an area of the home that is considered an unconfined space, the natural infiltration of air around windows and doors will be adequate. If the area is considered a confined space (less than 50 cubic feet per 1,000 btu), fresh air can be supplied by providing two permanent openings into adjoining rooms. Each opening shall have a minimum free area of one square inch per 1,000 btu per hour of the total input rating of all gas appliances in the confined space, but not less than 100 square inches. One of the openings shall be within 12 inches of the ceiling and one within 12 inches of the floor. See Figure A.

If the home is of unusually tight construction (new and remodeled homes), free air must be supplied through opening(s) to the outdoors. This can be accomplished by providing 2 permanent openings, one commencing within 12 inches of the ceiling and one within 12 inches of the floor. These openings shall communicate directly with the outdoors, or spaces that communicate freely with the outdoors, such as a ventilated attic and crawl space through galvanized or equivalent corrosion-resistant ducts. Exception: unobstructed stud and joist spaces are acceptable ducts provided that not more than one fire block is removed. Special provisions must be taken to insure that these stud and joist spaces cannot be blocked with insulation or other objects. Each of these openings using vertical ducts shall have a minimum free area of one square inch per 4,000 btu/hr of total input rating of all gas appliances. See Figure B and C. If horizontal ducts are used, the minimum free area shall be one square inch per 2,000 btu/hr of total input rating of all gas appliances.

Fresh make-up air can also be provided through a duct to one permanent opening commencing within 12 inches of the ceiling. The minimum free area of this opening shall be one square inch per 3,000 btu/hr of the total input rating of all gas appliances but not less than the sum of the areas of all vent connectors in the space. See Figure D.

When calculating the amount of fresh air needed you must include make-up air requirements for the operation of exhaust fans, kitchen ventilation systems, clothes dryers, and fireplaces.

Additional information can be found in the latest edition of ANSI Z223.1 (National Fuel Gas Code).

**F
I
G
U
R
E
A**

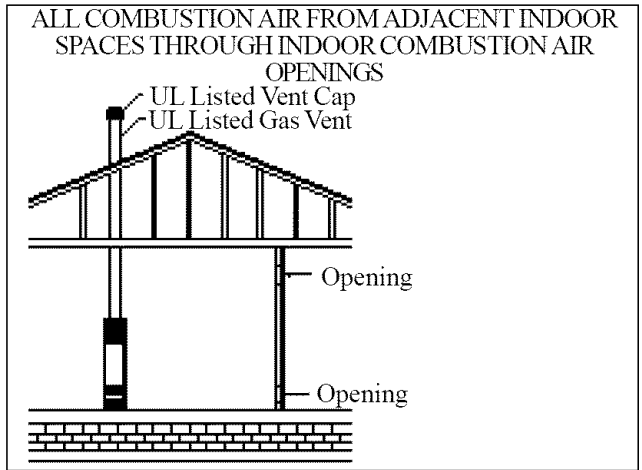

**F
I
G
U
R
E
B**

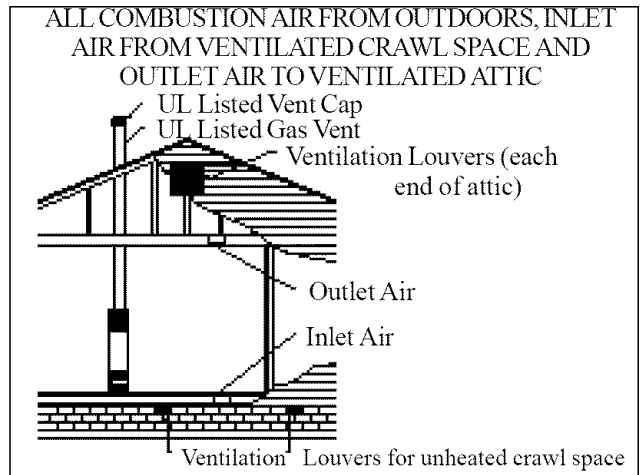

**F
I
G
U
R
E
C**

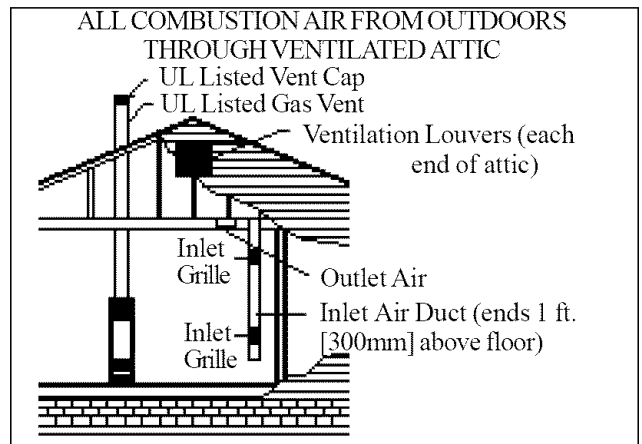

**F
I
G
U
R
E
D**

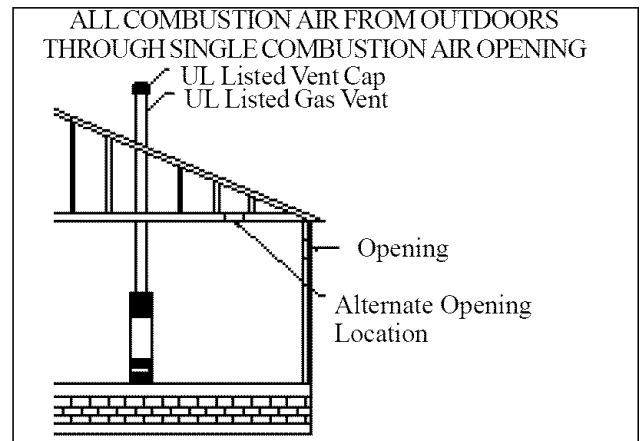

USING ADJACENT STUD SPACE FOR ALL COMBUSTION AIR FROM OUTSIDE

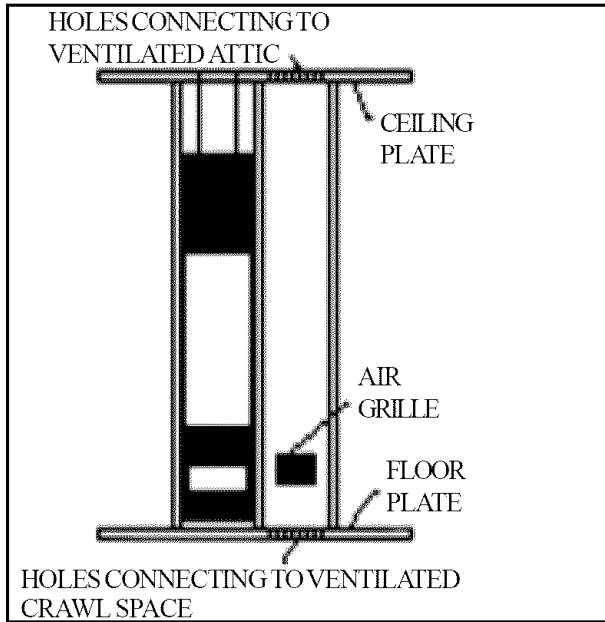

BASED ON 4,000 BTU OF TOTAL INPUT RATING OF ALL GAS APPLIANCES, THE HEATER ONLY REQUIRES A MINIMUM FREE AREA OF:

BTU	SQUARE IN.	HOLE SIZE =	SQUARE IN.
25,000	6.25	1"	.785
35,000	8.75	1.5"	1.76
50,000	12.50	2"	3.14
55,000	13.75	2.5"	4.90
65,000	16.25	3"	7.065

ROUGH-IN INSTRUCTIONS

In selecting a location for installation, it is necessary to provide adequate accessibility clearances for servicing and proper operation.

Minimum clearance from cabinet to combustible construction:

- Side Wall - 4"
- Floor - 0"
- Ceiling - 4"

See Figure 2. The unit may be recessed and rest directly against side studs and the inside surface of the rear wall.

ELECTRICAL ROUGH-IN

Rough in 115 v. wiring, terminating inside the junction box located on top of header plate for recessed, or in a receptacle box (not provided) for flush mount. Consult local codes or ordinances. See Figure 3.

MODEL NUMBER	AMPS
CF353C, CF354C	1.95
CF503C, CF504C	2.25
CF653C, CF654C	2.25

CF357C	2.2
CF358C	2.25
CF557C	2.5
CF558C	2.55

LOCATION AND SPECIAL PRECAUTIONS

The wall furnace should be located near the center of the house for best heat distribution.

If the area where the appliance is to be installed contains carpeting, tile or combustible materials, other than wood flooring, the appliance shall be installed on a metal plate, wood panel or other non-combustible materials. The use of ceramic or quarry tile is acceptable and will provide a surface that is easily cleaned. This material is to extend the full width and depth of the appliance. If side or rear warm air outlets are being installed, see figure 14 – 18, See page 16 and 17.

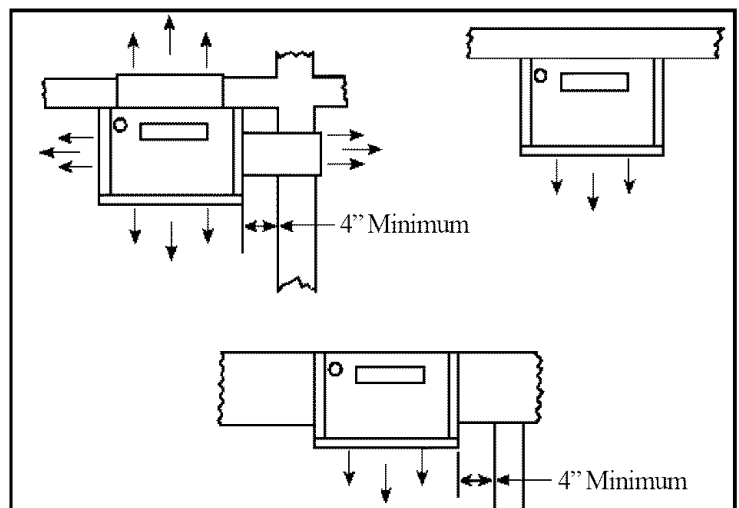

FIGURE 2

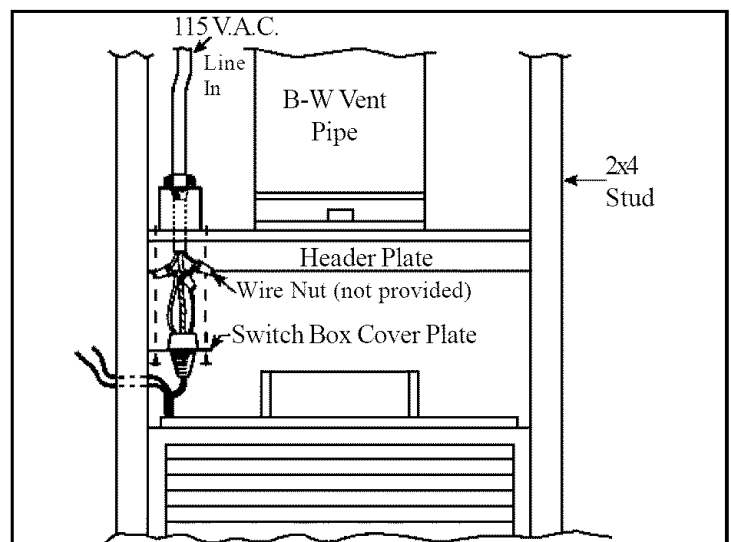

FIGURE 3

GAS ROUGH-IN

Check local codes for requirements as to the size and type of gas line required. See Figure 5 for location of gas inlet holes in furnace cabinet.

Compounds used on threaded joints of gas pipe should be resistant to the action of liquefied petroleum gases. The gas line joints must be checked for leaks. This should be done with a soap solution – watching for bubbles on all connections. NEVER USE AN EXPOSED FLAME TO CHECK FOR LEAKS.

A manual valve equipped with a 1/8" NPT plugged tapping accessible for test gauge connection should be installed immediately upstream of the gas supply connection to the appliance. Some codes and ordinances require that the manual valve be located outside the appliance. See Figure 4.

The appliance and its individual shut off valve must be disconnected from the gas supply piping system during any pressure testing of that system at test pressures in excess of 1/2 psig.

The appliance must be isolated from the gas supply piping system by closing its individual manual shut off valve during any pressure testing of the gas supply piping system at test pressures equal to or less than 1/2 psig.

It is required by the National Fuel Gas Code that a drip line be installed near the gas inlet. This should consist of a vertical length of pipe tee connected into the gas line that is capped on the bottom in which condensation and foreign particles may collect.

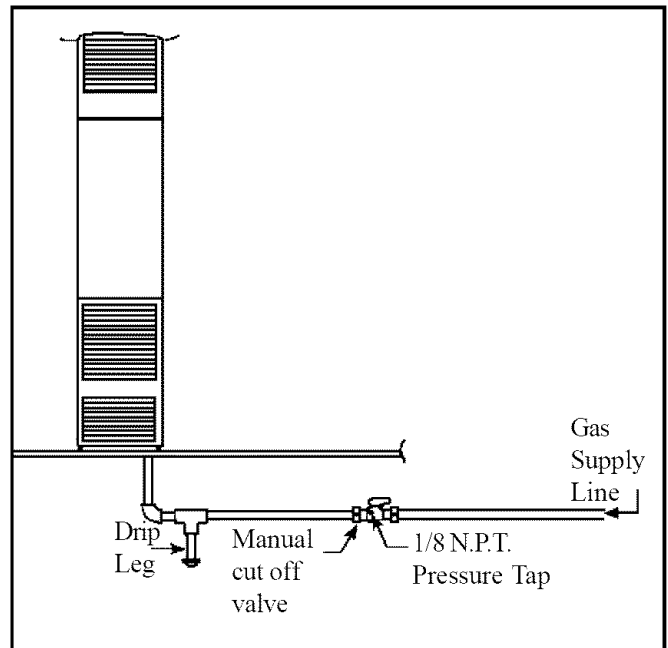

FIGURE 4

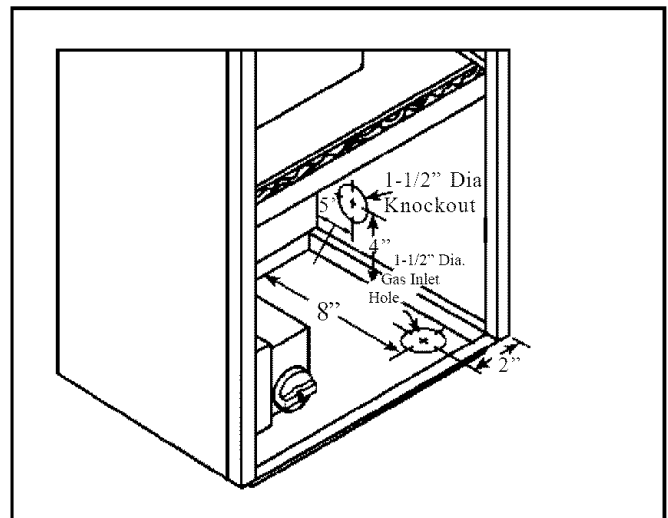

FIGURE 5

INSTALLATION / WHEN RECESSED
(UP TO 9-1/4")

- STEP 1.** Cut out floor plate between 2x4 studs, so heater will set flat on floor.
- STEP 2.** Make electrical connection of 115 V. wiring into junction box provided on top of header plate.
- STEP 3.** Attach the base plate (purchased with the vent pipe) to the header plate using two No. 8 sheet-metal screws through the pre-punched holes. See Figure B.
- STEP 4.** Square up and nail header plate in place between 2x4 studs placed on 16" centers (14-3/8" between studs). For distances from top of header plate to floor, see Figure 6.
- STEP 5.** Remove double ceiling plate between studs. Install one ceiling plate spacer across the cut out in ceiling plate. Install vent pipe into position, be sure to lock bottom of vent pipe into the base plate. Nail second ceiling plate spacer in place. See Figure B.
- STEP 6.** If the vent continues through additional stories within the 2x4-stud space, then fire stop spacers must be installed at the second and subsequent ceiling levels. See Figure C.
- STEP 7.** To place furnace into position, grasp furnace and lift so furnace flue vent and header plate vent opening engage. Plug power cord from top of heater into receptacle on bottom of the header plate, see Figure 3. Run thermostat wire through a drilled hole into an adjacent stud space. Do not route it behind the header plate. To do so may cause the thermostat wiring to chaff resulting in the appliance operating continually. Connect thermostat wire with thermostat wires extending from top of heater. Lift furnace upward and swing bottom into wall, see Figure 7. Secure furnace in place using 2 holes provided in bottom of casing.
- STEP 8.** Make gas connection using connector the same size as gas connection of furnace. CHECK ALL CONNECTIONS FOR GAS LEAKS WITH LEAK DETECTOR SOLUTION. DO NOT USE OPEN FLAME.
- STEP 9.** Replace and fasten front panels to furnace.

NOTE: FOR PROPER COMBUSTION, MAKE SURE UNITS ARE LEVEL FRONT TO BACK AND SIDE TO SIDE.

INSTALLATION
WHEN INSTALLED FLUSH TO WALL

- STEP 1.** After locating furnace, cut 3-1/2"x12" rectangular hole in ceiling between ceiling joists. Make sure gasket is in position on the top of the furnace casing around the flue vent opening. Remove vent collar from top of header plate and place over flue extension and fasten to matching holes in casing top, using screws from header plate. Install B vent type base plate (not supplied) to top of vent collar. Install ceiling plate spacer to back wall, centered between studs. Install B type vent to top of furnace, terminating at least 12' above the floor and at least 2' above the roof line.
- STEP 2.** Fasten furnace to wall. To secure top of furnace to wall, loosen top screws on back casing and raise tabs up. Tighten screws. Screw through hole in top of tabs into anchors (not provided). Secure bottom using two holes provided in bottom of casing. (Optional) Cover exposed vent with a vent enclosure kit, Part Number 16VE-A or 36VE-A (not included).
- STEP 3.** Make electrical connection of 115 V. wiring into receptacle box (not provided) mounted on a wall. Plug power cord from top of heater into receptacle. Connect thermostat wire with thermostat wires extending from top of heater. According to installation instructions with thermostat, do not run wires in same stud space with vent system. Thermostat should be a minimum of 4' from heater and 5' from floor.
- STEP 4.** Make gas connection using connector the same size as gas connection of furnace. CHECK ALL CONNECTIONS FOR GAS LEAKS WITH LEAK DETECTOR SOLUTION. DO NOT USE OPEN FLAME.
- STEP 5.** Replace and fasten all front panels.

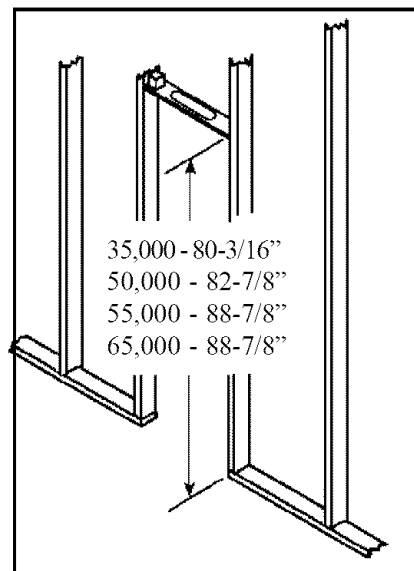

FIGURE 6

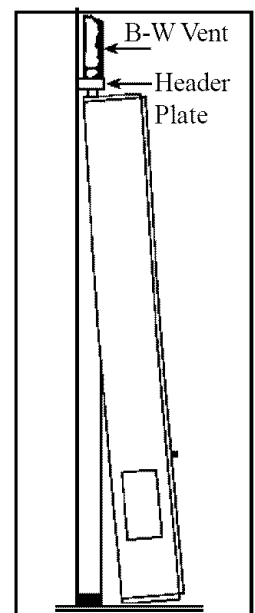

FIGURE 7

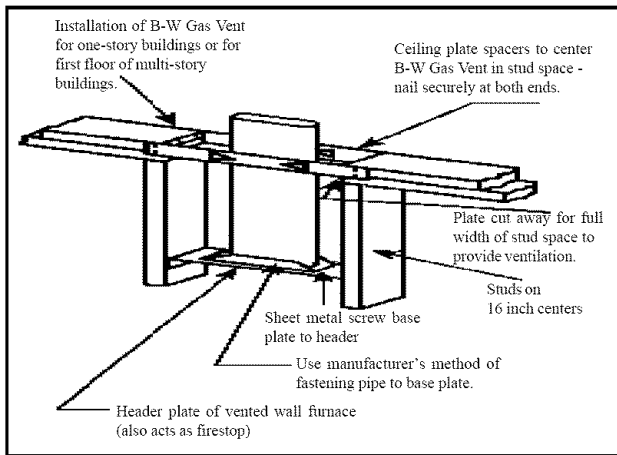

FIGURE B

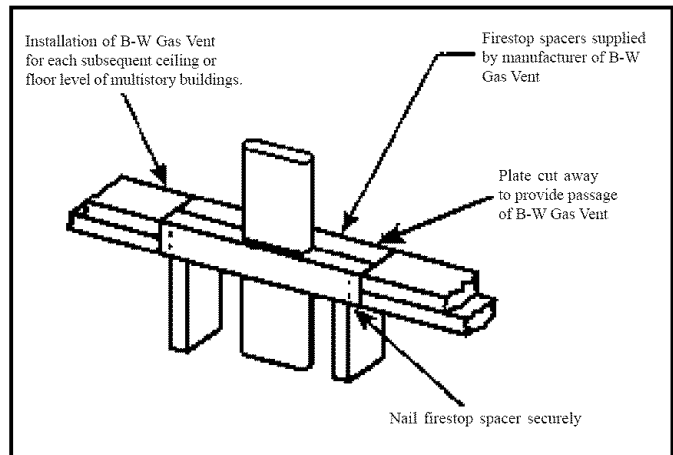

FIGURE C

CONTROLS

All controls are pre-assembled at the factory. The normal manifold pressure should be 3.5" w.c. for Natural Gas and 10" w.c. for L.P. Gas. The maximum inlet pressure in the gas supply pipe should never exceed 7.0" w.c. for Natural Gas or 14" w.c. for L.P. Gas. The minimum inlet pressure in the gas supply pipe should never be lower than 4.5" w.c. for Natural Gas or 11" w.c. for L.P. Gas.

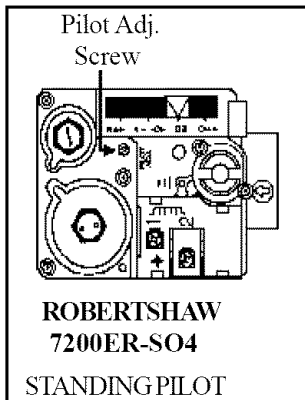

FIGURE 10-A

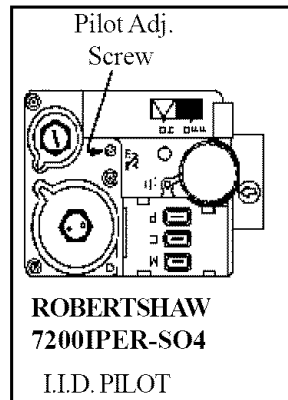

FIGURE 10-B

The appliance is orificed at the factory for elevations up to 2,000 feet. If installed above 2,000 feet, the BTU input must be reduced 4% per 1,000 feet. See the following orifice chart for the proper orifice for a specific elevation.

PILOT ADJUSTMENT

Locate the pilot adjustment screw on the valve. The pilot flame should surround at least the top 3/8" of the powerpile (pilot generator) or flame sensor (see Figure 8). The pilot is unregulated so it will be operating at inlet line pressure (maximum 7" w.c. for Natural Gas and 11" w.c. for Propane Gas). To decrease the pilot flame, turn the screw clockwise (approximately six full turns to bottom of pilot light channel) until you produce sufficient flame at the minimum noise level.

PILOT FLAME ADJUSTMENT

PILOT FLAME SHOULD ENVELOP 3/8 TO 1/2 INCH OF THE TIP OF THE GENERATOR.

NATURAL GAS

SPECIFIC ELEVATIONS

Model No.	0 to 2,000'	2,000 - 4,000'	4,000 - 6,000'	6,000 - 8,000'	8,000 - 10,000'
CF353C	34	36	37	38	41
CF357C	34	36	37	38	41
CF503C	3.4mm	31	31	32	35
CF557C	29	30	30	31	32
CF653C	26	27	28	29	30

ORDER KIT #49840 2287-1 HIGH ALTITUDE KIT

L.P. GAS

SPECIFIC ELEVATIONS

Model No.	0 to 2,000'	2,000 - 4,000'	4,000 - 6,000'	6,000 - 8,000'	8,000 - 10,000'
CF354C	50	52	52	53	54
CF358C	50	52	52	53	54
CF504C	45	47	48	49	50
CF558C	2.15mm	45	47	48	49
CF654C	42	43	44	45	47

ORDER KIT #49840 2287-1 HIGH ALTITUDE KIT

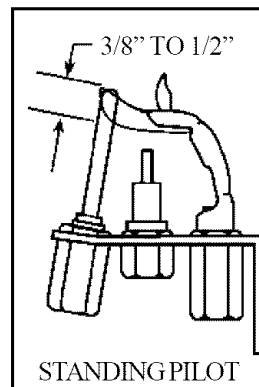

FIGURE 8-A

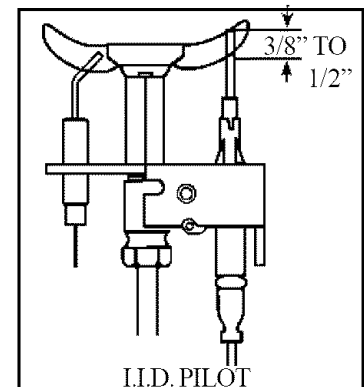

FIGURE 8-B

CF353C, CF354C, CF503C, CF504C, CF653C, CF654C - - STANDING PILOT

FOR YOUR SAFETY READ BEFORE LIGHTING

WARNING: If you do not follow these instructions exactly, a fire or explosion may result causing property damage, personal injury or loss of life.

- | | |
|--|--|
| <p>A. This appliance has a pilot, which must be lighted by hand. When lighting the pilot, follow these instructions exactly.</p> <p>B. BEFORE LIGHTING smell all around the appliance area for gas. Be sure to smell next to the floor because some gas is heavier than air and will settle on the floor.</p> <p>WHAT TO DO IF YOU SMELL GAS:</p> <ul style="list-style-type: none"> • Do not try to light any appliance. • Do not touch any electric switch; do not use any phone in your building. • Immediately call your gas supplier from a neighbor's phone. Follow the gas supplier's instructions. | <ul style="list-style-type: none"> • If you cannot reach your gas supplier, call the fire department. <p>C. Use only your hand to push in or turn the gas control knob. Never use tools. If the knob will not push in or turn by hand, don't try to repair it, call a qualified service technician. Force or attempted repair may result in a fire or explosion.</p> <p>D. Do not use this appliance if any part has been under water. Immediately call a qualified service technician to inspect the appliance and to replace any part of the control system and any gas control which has been under water.</p> |
|--|--|

LIGHTING INSTRUCTIONS

1. STOP! Read the information on the safety label.
2. Set thermostat to lowest setting.
3. Turn off all electric power to the appliance.
4. Remove cabinet door.
5. Push in gas control lever slightly and slide right to "OFF".

MAX. (HIGH)
PRESSURE REGULATOR

Gas Control
Lever

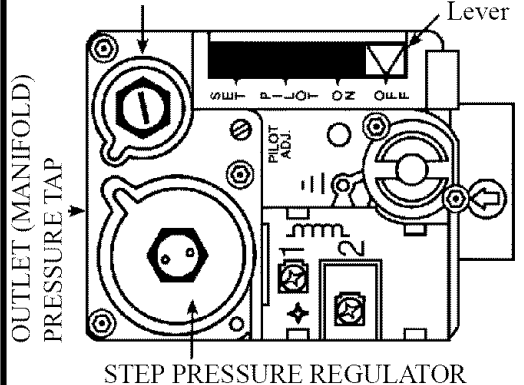

NOTE: Lever cannot be moved to "OFF" unless it is pushed in slightly. Do not force.

PILOT BURNER

The pilot is located on the side of the burner

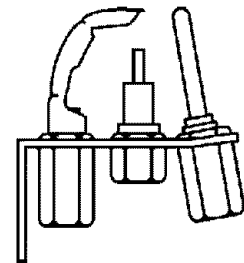

- | | |
|---|---|
| <ol style="list-style-type: none"> 6. Wait five (5) minutes to clear out any gas. Then smell for gas, including near the floor. If you smell gas, STOP! Follow "B" in the information on the safety label. If you don't smell gas, go to the next step. 7. Locate red piezo ignitor button. Locate pilot. (Follow metal pilot tube from gas control). | <ol style="list-style-type: none"> 8. Slide gas control lever left to "SET" and hold. Immediately begin a series of pushing and releasing the red piezo ignitor button, while observing the pilot. Continue to spark until pilot is lit. Continue to hold the gas control lever to "SET" for about one (1) minute after the pilot is lit. Release the gas control lever and it will return to "PILOT". Pilot should remain lit. If pilot goes out, repeat steps 5 thru 8. • If gas control lever does not return to "PILOT" when released, STOP and immediately call your service technician or gas supplier. • If the pilot will not stay lit after several tries, slide the gas control lever to "OFF" and call your service technician or gas supplier. 9. Slide gas control lever left to "ON". 10. Replace cabinet. 11. Turn on all electric to the appliance. 12. Set thermostat to desired setting. |
|---|---|

TO TURN OFF GAS TO APPLIANCE

- | | |
|--|---|
| <ol style="list-style-type: none"> 1. Turn thermostat to lowest setting. 2. Turn off all electric power to the appliance if service is to be performed. 3. Remove cabinet door. | <ol style="list-style-type: none"> 4. Push in gas control lever slightly and slide right to "OFF". Do not force. 5. Replace cabinet door. |
|--|---|

CF357C, CF358C, CF557C, CF558C - I.I.D. PILOT

FOR YOUR SAFETY READ BEFORE LIGHTING

WARNING: If you do not follow these instructions exactly, a fire or explosion may result causing property damage, personal injury or loss of life.

- | | |
|--|--|
| <p>A. This appliance is equipped with an ignition device which automatically lights the pilot. Do <u>not</u> try to light the pilot by hand.</p> <p>B. BEFORE LIGHTING smell all around the appliance area for gas. Be sure to smell next to the floor because some gas is heavier than air and will settle on the floor.</p> <p>WHAT TO DO IF YOU SMELL GAS:</p> <ul style="list-style-type: none"> • Do not try to light any appliance. • Do not touch any electric switch; do not use any phone in your building. • Immediately call your gas supplier from a neighbor's phone. Follow the gas supplier's instructions. | <ul style="list-style-type: none"> • If you cannot reach your gas supplier, call the fire department. <p>C. Use only your hand to push in or turn the gas control knob. Never use tools. If the knob will not push in or turn by hand, don't try to repair it, call a qualified service technician. Force or attempted repair may result in a fire or explosion.</p> <p>D. Do not use this appliance if any part has been under water. Immediately call a qualified service technician to inspect the appliance and to replace any part of the control system and any gas control which has been under water.</p> |
|--|--|

LIGHTING INSTRUCTIONS

- | | |
|--|---|
| <ol style="list-style-type: none"> 1. STOP! Read the information on the safety label. 2. Set the thermostat to its lowest setting. 3. Turn off all electric power to the appliance. 4. This appliance is equipped with an ignition device which automatically lights the pilot. Do <u>not</u> try to light the pilot by hand. 5. Remove cabinet door. 6. Push in gas control lever slightly and slide right to "OFF". | <ol style="list-style-type: none"> 7. Wait five (5) minutes to clear out any gas. Then smell for gas, including near the floor. If you smell gas, STOP! Follow "B" in the information on the safety label. If you don't smell gas, go to the next step. 8. Slide gas control lever left to "ON". |
|--|---|

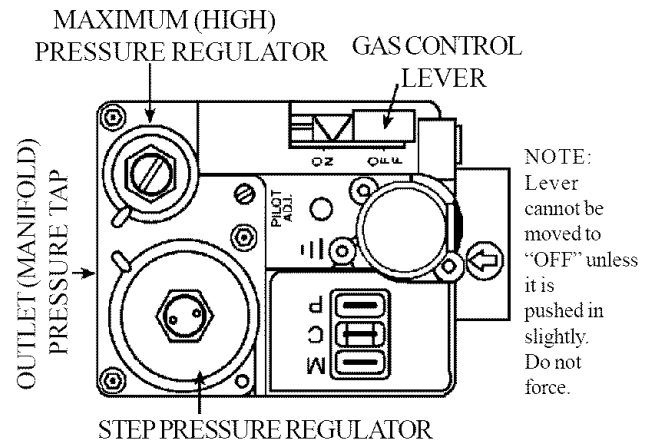
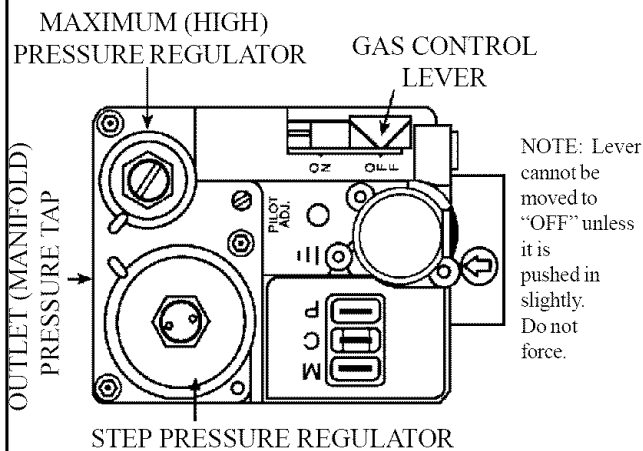

9. Replace cabinet door.
10. Turn on all electric power to the appliance.
11. Set thermostat to desired setting.
12. If the appliance will not operate, follow the instructions "TO TURN OFF GAS TO APPLIANCE" and call your service technician or gas supplier.

TO TURN OFF GAS TO APPLIANCE

- | | |
|---|--|
| <ol style="list-style-type: none"> 1. Turn thermostat to it's lowest setting. 2. Turn off all electric power to the appliance if service is to be performed. 3. Remove cabinet door. | <ol style="list-style-type: none"> 4. Push in gas control lever slightly and slide right to "OFF". Do not force. 5. Replace cabinet door. |
|---|--|

PROPER BURNER FLAME

A proper flame will have a dark blue inner mantle that sits right on top of the burners with a lighter blue outer mantle rising above the burner, (See Figure 11). There may be some yellow where the pilot flame and burner flame meet. There is no primary air adjustment on the burner, and proper flame is assured since the correct manifold pressure and orificing has been done at the factory. NOTE: It is advised that the burner flames be checked at least twice during the heating season for any changes in burner flame characteristics. The appliance area must be kept clear and free from combustible materials, gasoline, and other flammable vapors and liquids. This heater comes from the factory with the proper burner orifice for elevations up to 2,000 feet. Heaters installed above 2,000 feet must be derated 4% for every 1,000 feet. For the proper orifice size find the Model Number and elevation on the orifice chart (See CONTROLS). Replace burner orifice.

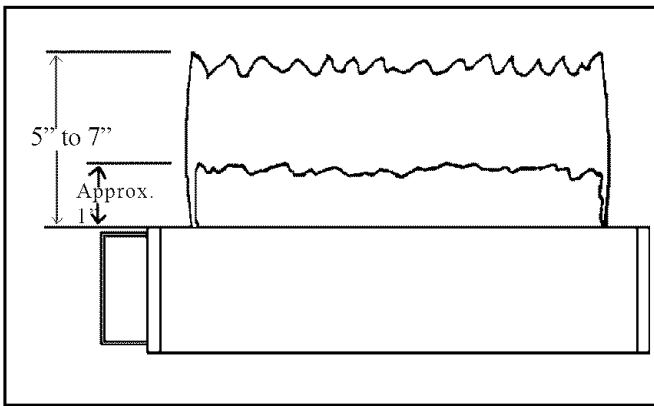

FIGURE 11

OPERATION

This unit uses a “step open” valve. When heat is called for the gas valve opens at a reduced manifold (outlet) pressure to insure a safe, quiet ignition. After 10 – 20 seconds the valve automatically steps up to normal manifold outlet pressure to provide proper BTU input for the remainder of the heat cycle.

After the heat exchanger has warmed sufficiently, the fan will automatically come on to efficiently transfer the heat into the room. NOTE: All but the 35,000 BTU unit (which is one speed) have an automatic two-speed fan. In a new installation or on fall start-up in a very cold room, some on-off cycling of the fan may occur if the heat exchanger cools too much. The burner, however, will continue to operate and the fan cycle until the thermostat is satisfied.

TERMINAL BLOCK WIRING DIAGRAM

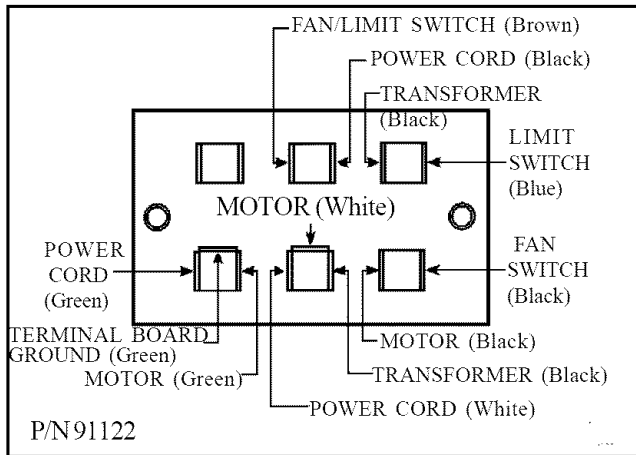

CF353C, CF354C, CF357C, CF358C

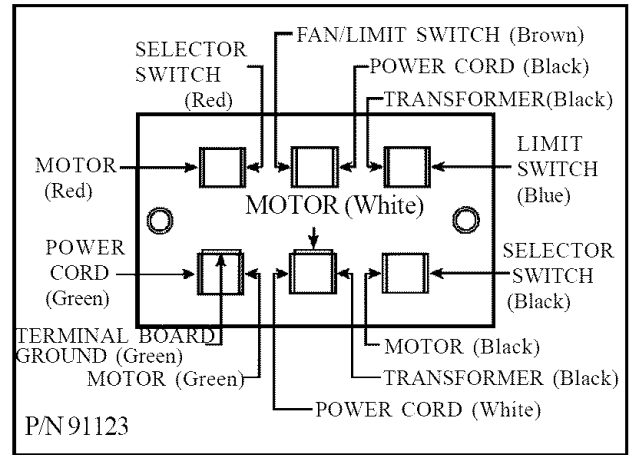

CF503C, CF504C, CF557C, CF558C, CF653C, CF654C

CAUTION: Label all wires prior to disconnection when servicing controls. Wiring errors can cause improper and dangerous operation. Verify proper operation after servicing.

AUXILIARY LIMIT SWITCH

For your safety this furnace is equipped with a manual reset auxiliary limit switch. In case of failure by the primary limit switch, this switch will shut the valve down completely before unsafe temperatures are reached. After a cool down period, switch must be manually reset. If outages persist, call a qualified service person.

MAINTENANCE INSTRUCTIONS

1. Installation and repair must be done by a qualified service person. The appliance should be inspected before use and at least annually by a professional service person. More frequent cleaning may be required due to excessive lint from carpeting, bedding material, etc. It is imperative that control compartments, burners, pilot burners, circulating air passageways and venting systems of the appliance be kept clean.
2. The bearings of the motor should be oiled every six months with S.A.E. 20 oil.
3. The appliance area must be kept clear and free of any combustible materials, gasoline and other flammable vapors and liquids.
4. It is essential that the flow of combustion and ventilation air not be obstructed.
5. Periodic examination of the entire ventilation system as a routine part of the safety performance check is recommended on an annual basis.

IMPORTANT: Keep burner and control compartment clean. Vacuum burner compartment at the start of the heating season or as often as needed.

NOTE: It is advised that the burner flames be checked at least twice during the heating season for any changes in burner flame characteristics.

115 VAC 60 HZ – Less than 12 Amps. If any of the original wire as supplied with this appliance must be replaced, it must be replaced with type thermoplastic 105-degree C wire or its equivalent.

CF353C, CF354C

STANDING PILOT

CF503C, 504C, 653C, 654C

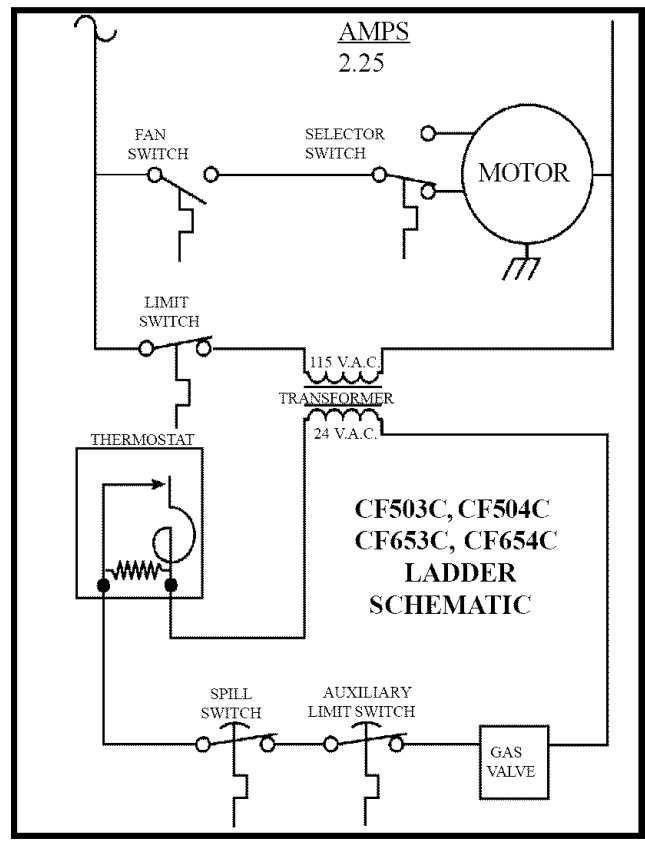
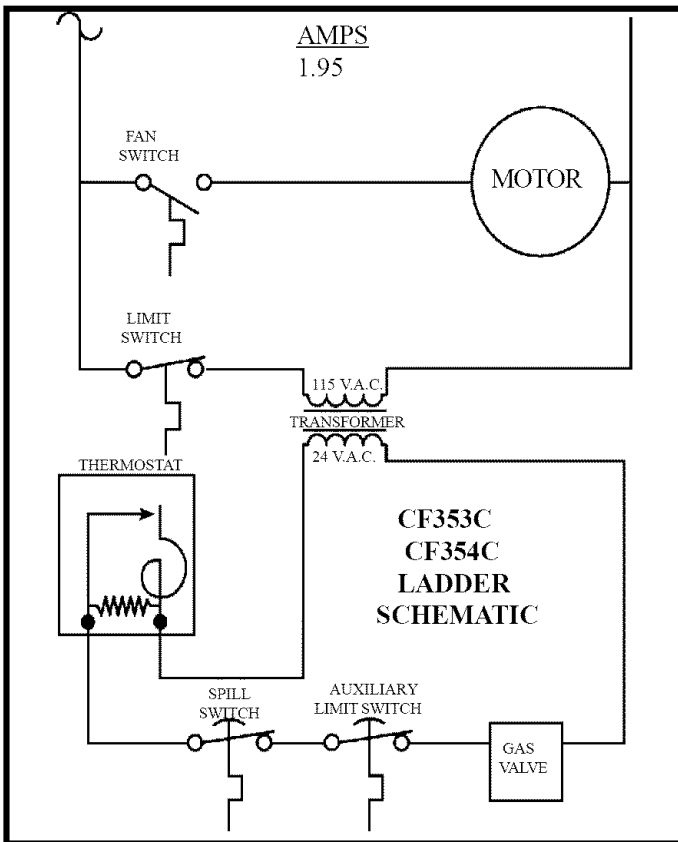
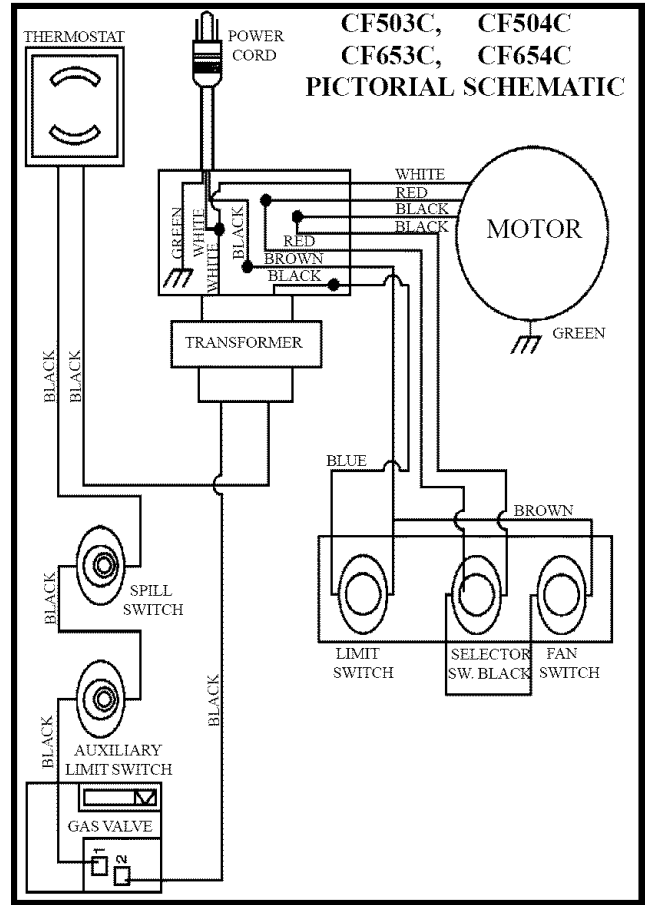
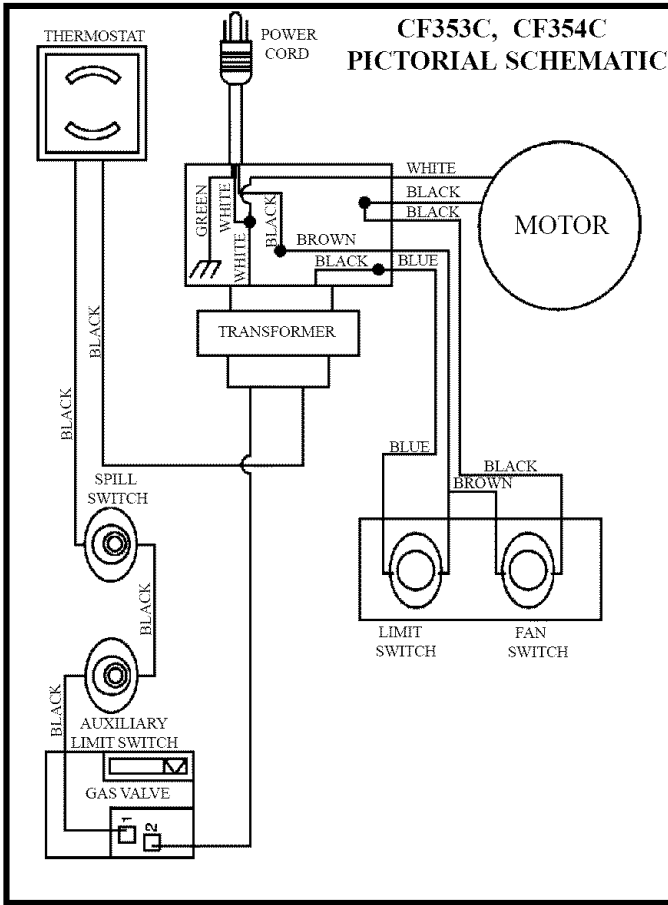

CF357C, CF358C

I.I.D.

CF557C, CF558C

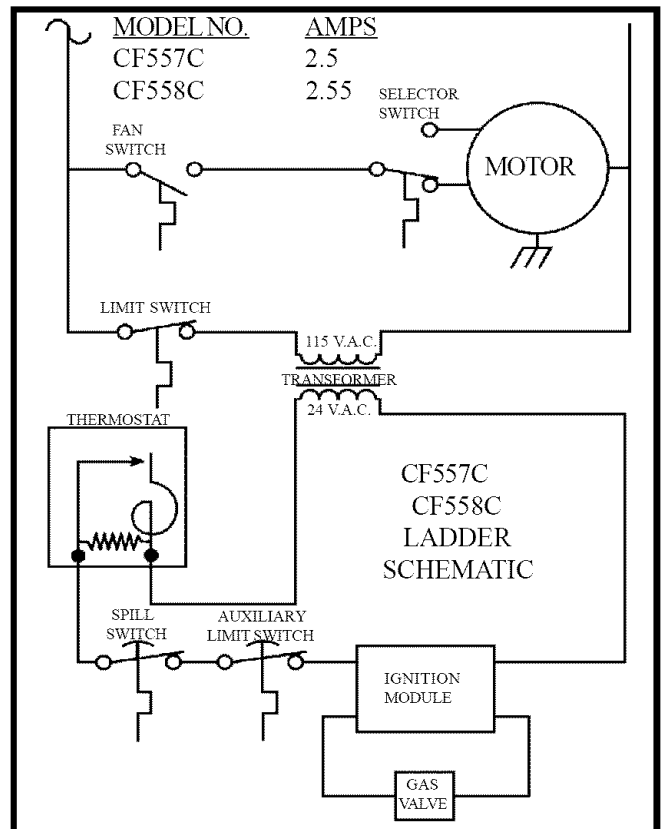
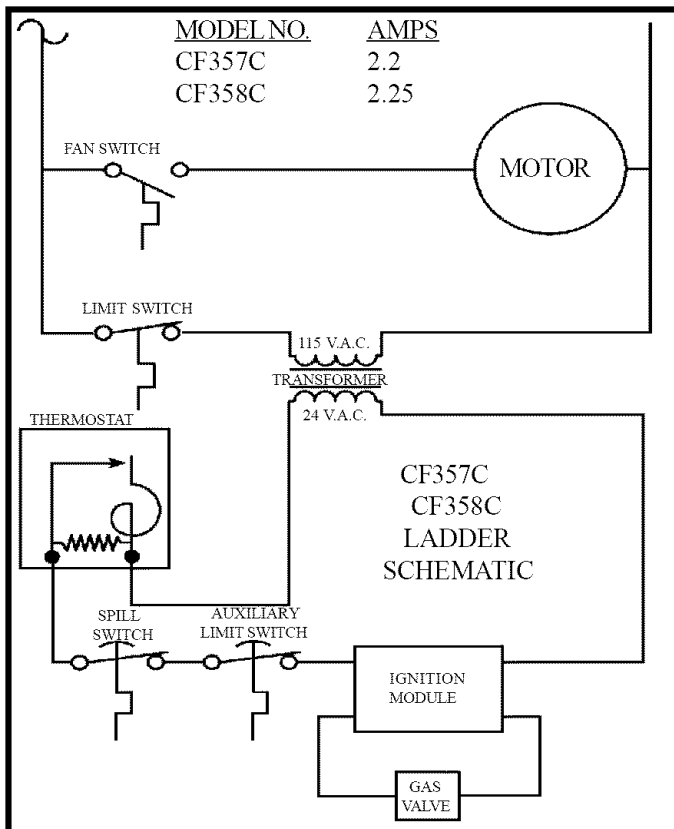
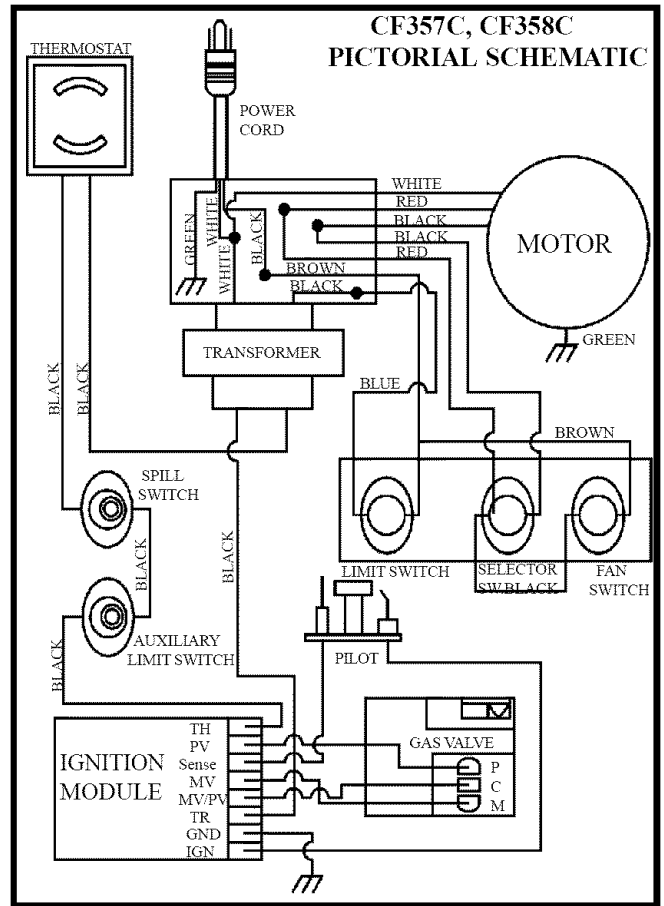
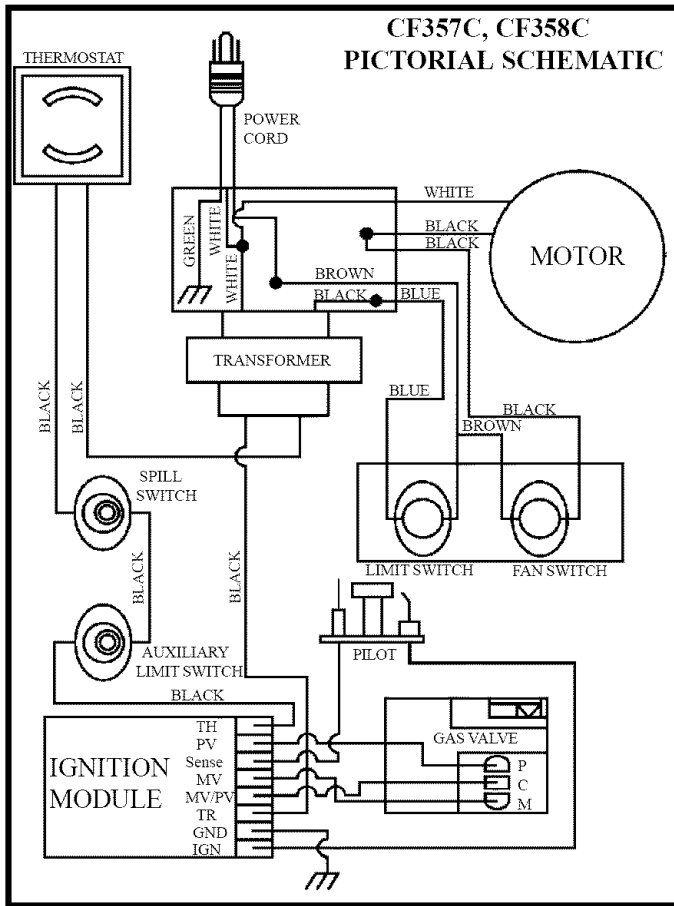

ROUGH-INS FOR REAR OR SIDE DISCHARGE

Install plastergrounds as shown in Figure 12 and Figure 13.

NOTE: When side discharge is being used, furnace should be set exactly 4" from side wall.

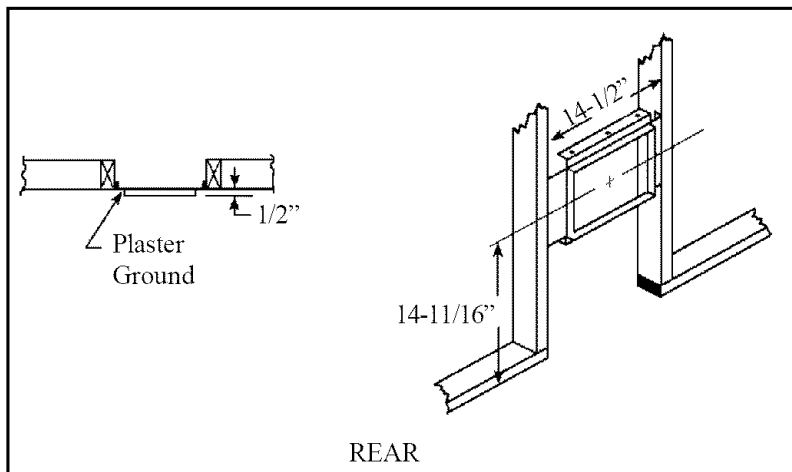

FIGURE 12

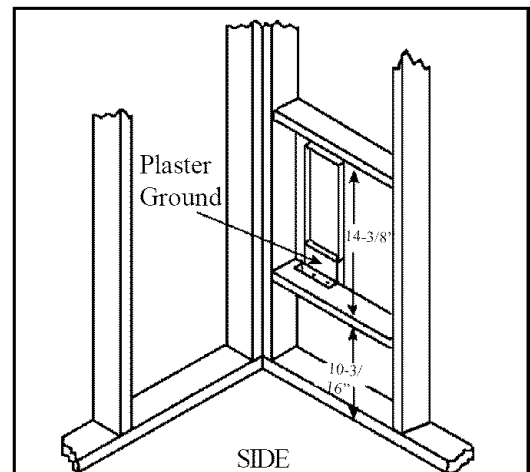

FIGURE 13

OPTIONAL ACCESSORY KITS

REAR REGISTER KIT (Flush Mount)

(See Figure 14)

1. Use optional kit No. 406RR-A.
2. Cut openings in drywall as shown in Figure 12.
3. Position plasterground as shown in Figure 12 (Optional).
4. Cut out and remove embossed section on casing rear.
5. Remove knockout on inner liner.
6. Put heater into position.
7. Place inner boot into position, mark and cut boot flush with wall. Place damper into cutout end of inner boot, mark (4) holes from damper onto inner boot, top and bottom, and drill (4) 1/8" hole. Place outer boot into position, mark and cut boot flush with wall.
8. Attach inner boot to liner. Attach damper to inner boot (screws provided). Attach outer boot to casing back.
9. Place grill in position and secure to wall.
10. Final installation will appear as Figure 14.

REAR DISCHARGE KIT (Recessed)

1. Use optional kit No. 407RR-A.
2. Cut openings in wall as shown in Figure 13.
3. Cut out and remove embossed section on casing rear.
4. Remove knockout from inner liner.
5. Place inner boot from kit through opening, matching flanges of boot and knockout.
6. Mark screw holes and remove boot.
7. Drill holes with a 1/8" drill.
8. Repeat steps 5 & 6 for outer boot.
9. After unit has been set in wall, shove the inner boot through the back wall and up against the liner. Secure boot with screws provided. Attach damper to inner boot with screws provided.
10. Repeat Step 9 for outer boot.
11. Place grille in place and secure to wall.
12. Final installation will appear as Figure 15.

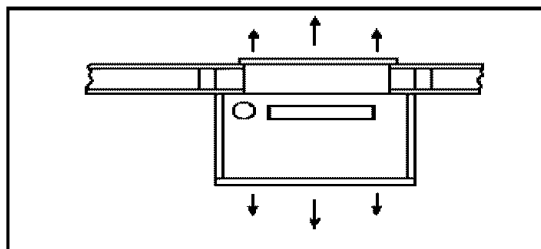

FIGURE 14

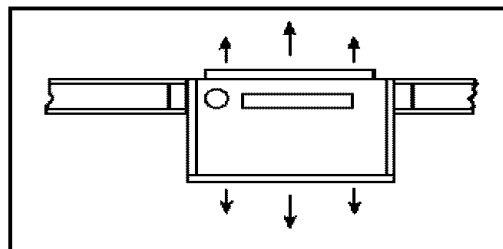

FIGURE 15

(OPTIONAL KITS
CONTINUED -
REVERSE SIDE)

OPTIONAL KITS - CONTINUED

SIDE DISCHARGE ON CASING

1. Use optional kit No. 306SR-A.
2. Cut out and remove embossed area on casing side.
3. Remove knockout from inner liner.
4. Place 1-1/2" boot from kit through opening, matching flanges of boot to knockout on inner boot.
5. Mark screw holes and remove boot.
6. Drill holes with a 1/8" drill.
7. Attach inner boot with screws provided.
8. Place grille into position, drill holes into casing, and attach with screws provided.

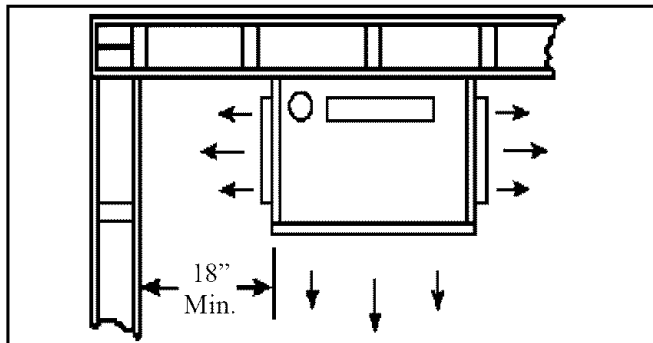

FIGURE 16

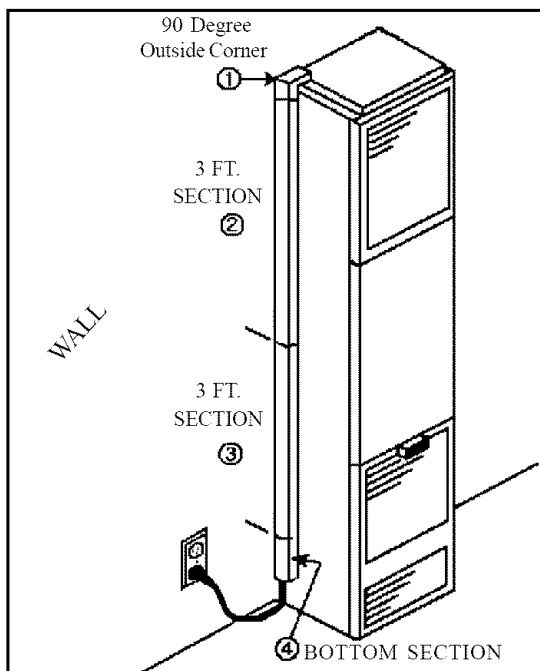

FIGURE 18

MODEL NUMBER	Length of bottom section (Ref. 4) plastic raceway
CF35	5-5/16 Inches
CF50	8 Inches
CF55	14 Inches
CF65	14 Inches

NOTE: Above lengths terminate approximately 2 inches above floor.

SIDE DISCHARGE (With Extension Boot)

1. Use optional kit No. 30SRB-A.
2. Cut opening in drywall as shown in Fig. 17.
3. Position plasterground as shown in Fig. 17 (optional).
4. Cut out and remove embossed section on casing side.
5. Remove knockout on inner liner.
6. Put heater into position.
7. Place inner boot into position, mark and cut boot flush with wall. Place outer boot into position, mark and cut boot flush with wall.
8. Place boot trim into position, slide inner boot through wall from adjacent room and attach to inner liner. Slide outer boot through wall from adjacent room and attach to casing side.
9. Place grille into position and secure to wall.

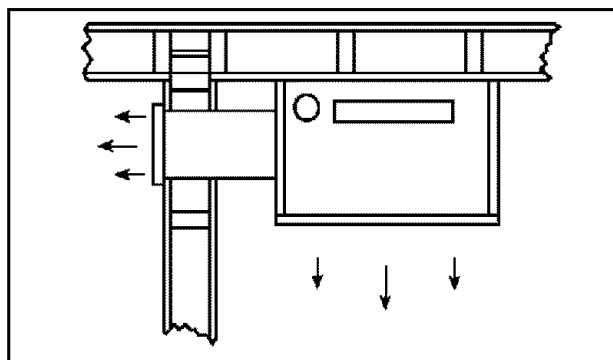

FIGURE 17

14PEK-A PLUG EXTENSION KIT INSTRUCTIONS FOR NON-RECESSED INSTALLATION ONLY

UNITS WITH TERMINAL BOARD

- STEP 1.** Turn heater off following Section 3 in "Lighting Instructions" and allow to cool.
- STEP 2.** Turn off all electricity to heater.
- STEP 3.** Remove top louver assembly, fan shroud and fan blade.
- STEP 4.** Loosen two screws on romex connector.
- STEP 5.** Remove junction box cover plate.
- STEP 6.** Disconnect three power cord terminals and pull power cord out of top of heater.
- STEP 7.** Insert power cord provided in kit through romex connector and plug onto terminal board following wiring diagram found in lighting and operating instructions.
- STEP 8.** Tighten two screws on romex connector.
- STEP 9.** Replace junction box cover plate.
- STEP 10.** Replace fan blade, fan shroud and top louver assembly.
- STEP 11.** Snap 90 Degree outside corner (Ref. 1) onto 3 ft. section (Ref. 2) plastic raceway. Insert power cord and remove blue backing from adhesive strip on raceway and apply to side of heater. See Figure 18.
- STEP 12.** Insert power cord into second 3 ft. section of raceway (Ref. 3) and remove blue backing and apply to side of heater, butting up against bottom of other section. See Fig. 18.
- STEP 13.** Cut 14 inch long bottom section to required length (see chart), insert power cord, remove backing and apply to side of heater. See Fig. 18.
- STEP 14.** Plug power cord into wall receptacle, see Fig.18.
- STEP 15.** Light the heater following lighting instructions.

TROUBLE SHOOTING CHART for qualified serviceman - MAIN BURNER

SYMPTOM	POSSIBLE CAUSES	CORRECTIVE ACTION
Flame too large	<ol style="list-style-type: none"> 1. Defective operator section of gas valve. 2. Burner orifice too large. 3. If installed above 2,000 ft. 	<ol style="list-style-type: none"> 1. Replace complete valve. 2. Check with local gas company for proper orifice size and replace. 3. Refer to orifice chart on Page 9.
Noisy Flame	<ol style="list-style-type: none"> 1. Noisy pilot. 2. Burr in orifice (if it whistles or resonates). 3. Excessive gas input. 	<ol style="list-style-type: none"> 1. Reduce pilot gas with adjusting screw on combination gas control valve. 2. Remove burr or replace orifice (do not enlarge orifices) 3. See "Flame Too Large" above.
Yellow tip flame (some yellow tipping on LP gas is permissible)	<ol style="list-style-type: none"> 1. Clogged main burner ports. 2. Clogged draft hood. 3. Linted up mixer opening. 	<ol style="list-style-type: none"> 1. Clean main burner ports. (Do not enlarge ports). 2. Clean draft hood. 3. Check for dust or lint at air mixer opening.
Floating Flame	<ol style="list-style-type: none"> 1. Blocked venting. 	<ol style="list-style-type: none"> 1. Clean flue passageways to remove blockage.
Gas Odor	<ol style="list-style-type: none"> 1. Gas leak. 2. Chimney or flue obstruction. 3. Drafts around appliance. 	<ol style="list-style-type: none"> 1. Shut off gas service immediately. Check piping. Call gas company. See "For Your Safety", Page 1. 2. Clean flue. 3. Eliminate drafts.
Delayed Ignition	<ol style="list-style-type: none"> 1. Pilot flame too small. 2. Burner ports clogged near pilot. 3. Low gas pressure. 4. Pilot decreases in size when main burners come on. 5. Drafts around appliance. 6. Bad venting. 	<ol style="list-style-type: none"> 1. Check pilot orifice. Increase pilot gas flow if necessary by adjusting inlet pressure from gas source (meter if natural gas or second stage regulator if propane - maximum 7" w.c. for Natural and 11" w.c. for propane). 2. Clean burner ports (do not enlarge ports). 3. Check gas supply inlet pressure. Check gas outlet (manifold) pressure for "minimum step" pressure (for "step" pressure chart see "Operation"). 4. Supply piping inadequately sized or incorrect inlet pressure. 5. Eliminate drafts. 6. See "Venting".
Failure to Ignite	<ol style="list-style-type: none"> 1. Main gas off. 2. Defective gas valve. 	<ol style="list-style-type: none"> 1. Open all manual gas valves. 2. Replace gas valve.
Condensation of Water Vapor	<ol style="list-style-type: none"> 1. Improper venting. 	<ol style="list-style-type: none"> 1. See "Venting".
Burner won't turn off	<ol style="list-style-type: none"> 1. Defective or sticking automatic valve. 2. Excessive gas pressure (The supply gas pressure must not exceed 1/2 psi or 14" w.c. 	<ol style="list-style-type: none"> 1. Replace valve. 2. To correct this situation contact the utility supplying the gas.
Incorrect Gas Input	<ol style="list-style-type: none"> 1. Gas input not checked. 2. Clogged orifice. 	<ol style="list-style-type: none"> 1. Re-check gas input. 2. Check orifice for clogging. If clogged, clean out the hole carefully with a smooth wood toothpick. (Do not in any way enlarge or distort it).
Not enough heat	<ol style="list-style-type: none"> 1. Appliance undersized. 2. Incorrect supply pressure. 	<ol style="list-style-type: none"> 1. This is especially true when a dwelling or room is enlarged. Have the heat loss calculated and compare to the appliance output (approx. 70% of input). Your gas company or installer can supply you with this information. If appliance is undersized, replace with correct size unit. 2. Check supply pressure as outlined above.
Too much heat	<ol style="list-style-type: none"> 1. Combination control valve sticks open. 	<ol style="list-style-type: none"> 1. Replace combination control valve.
TROUBLE SHOOTING CHART - PILOT AND VALVE		
Burner won't turn on	<ol style="list-style-type: none"> 1. Gas valve not turned on. 2. No voltage to valve. 3. Defective thermostat. 4. No 115 Volt Line Voltage. 5. Auxiliary limit switch open. 6. Blocked flue switch open. 7. Gas valve defective. 	<ol style="list-style-type: none"> 1. Turn gas valve to "on" position". 2. Check for 24 Volts to Valve. 3. Check wall thermostat. 4. Jump fan switch to check for voltage (fan will come on). 5. Push on red buton to close. 6. Push red button in to close. 7. Replace gas valve

TROUBLE SHOOTING CHART - PILOT AND VALVE - CONTINUED

SYMPTOM	POSSIBLE CAUSES	CORRECTIVE ACTION
Pilot won't light, or stay lit (STANDING PILOT)	<ol style="list-style-type: none"> 1. Air in line. 2. Defective thermocouple. 3. Pilot flame too low. 4. Manual reset switch not engaged. 	<ol style="list-style-type: none"> 1. Bleed line. 2. Replace thermocouple. 3. Adjust pilot flame. 4. Push on button.
Pilot won't light, or stay lit (I.I.D. PILOT)	<ol style="list-style-type: none"> 1. Sparker won't work. 2. Sparker won't light pilot. 3. Manual reset switch not engaged. 	<ol style="list-style-type: none"> 1. Check wire connections. 2.a. Pilot flame too lean. 2.b. Turn valve to "on" position. 2.c. Check for pilot restriction. 3. Push on button.

THE FOLLOWING IS A LIST OF POSSIBLE CAUSES AND CORRECTIVE ACTIONS FOR BLOCKED FLUE SWITCH PROBLEMS

POSSIBLE CAUSES	CORRECTIVE ACTION
1. Blockage in vent pipe	<ol style="list-style-type: none"> 1. A) Check vent pipe for blockage, such as bird nest, wasp nest, twigs, leaves, etc. 1. B) Check inside the bottom of the vent pipe to make sure the top of the draft diverter did not rip the inner liner causing it to block part of the vent opening. 1. C) Check that no insulation from the header plate got caught on top of the draft diverter when the heater was inserted into the wall. 1. D) Check that the vent cap is properly installed, not shoved too far down on the vent pipe.
2. Burner is overfiring	<ol style="list-style-type: none"> 2. A) Check the manifold pressure. 2. B) Check the rate, NOTE: This appliance was orificed for elevations up to 2,000 feet. When installed at higher elevations refer to orifice chart in "Controls" section of instructions for proper orifice size.
3. Improper vent system. A) Vent too short B) Restriction in vent system caused by offsets C) Incorrect vent pipe	<ol style="list-style-type: none"> 3. Correct vent system. <ol style="list-style-type: none"> A) The vent should terminate a minimum of 12 feet above the floor. See Figure 1. Also, the top of the vent must be at least 2 foot above any obstacle within a 10 foot radius, including the roof. See Figure A on Page 4. B) All type "B" vents shall extend in a generally vertical direction with offsets not exceeding 45 degrees, except that a vent system having not more than one 60 degree offset may be allowed. Any angle greater than 45 degrees from the vertical is considered horizontal. The total horizontal run of a vent plus the horizontal vent connector shall be not greater than 75 percent of the vertical height of the vent. C) Use listed BW type vent pipe. Do not use transite or any other type of ceramic pipe for venting. Do not use single wall pipe. When venting into a masonry chimney the chimney must be properly lined and sized for this gas furnace. The use of type B or a flexible chimney liner is recommended.
4. Incorrect header plate location.	4. Consult Figure 6 for correct header plate height.
5. Vent pipe not down on the header plate securely	5. You must use a base plate (obtained from the vent pipe manufacturer) on top of the header plate, or wall furnace. This will lock the vent pipe down and prevent the draft diverter from shoving it up.
6. Loose connections on the vent safety wiring harness	6. Check the connections on both the switch and the gas valve. Tighten if necessary.

DO NOT BYPASS THE BLOCKED FLUE SWITCH: TO DO SO COULD EXPOSE THE CONSUMER TO PROPERTY DAMAGE, PERSONAL INJURY OR POSSIBLE DEATH.

COUNTERFLOW WALL FURNACE / STANDING PILOT

Prices and specifications subject to change without notice. All prices are F.O.B. factory.

MODELS:

<u>NAT. GAS</u>	<u>L.P. GAS</u>
CF353C-R	CF354C-R
CF503C-R	CF504C-R
CF653C-R	CF654C-R

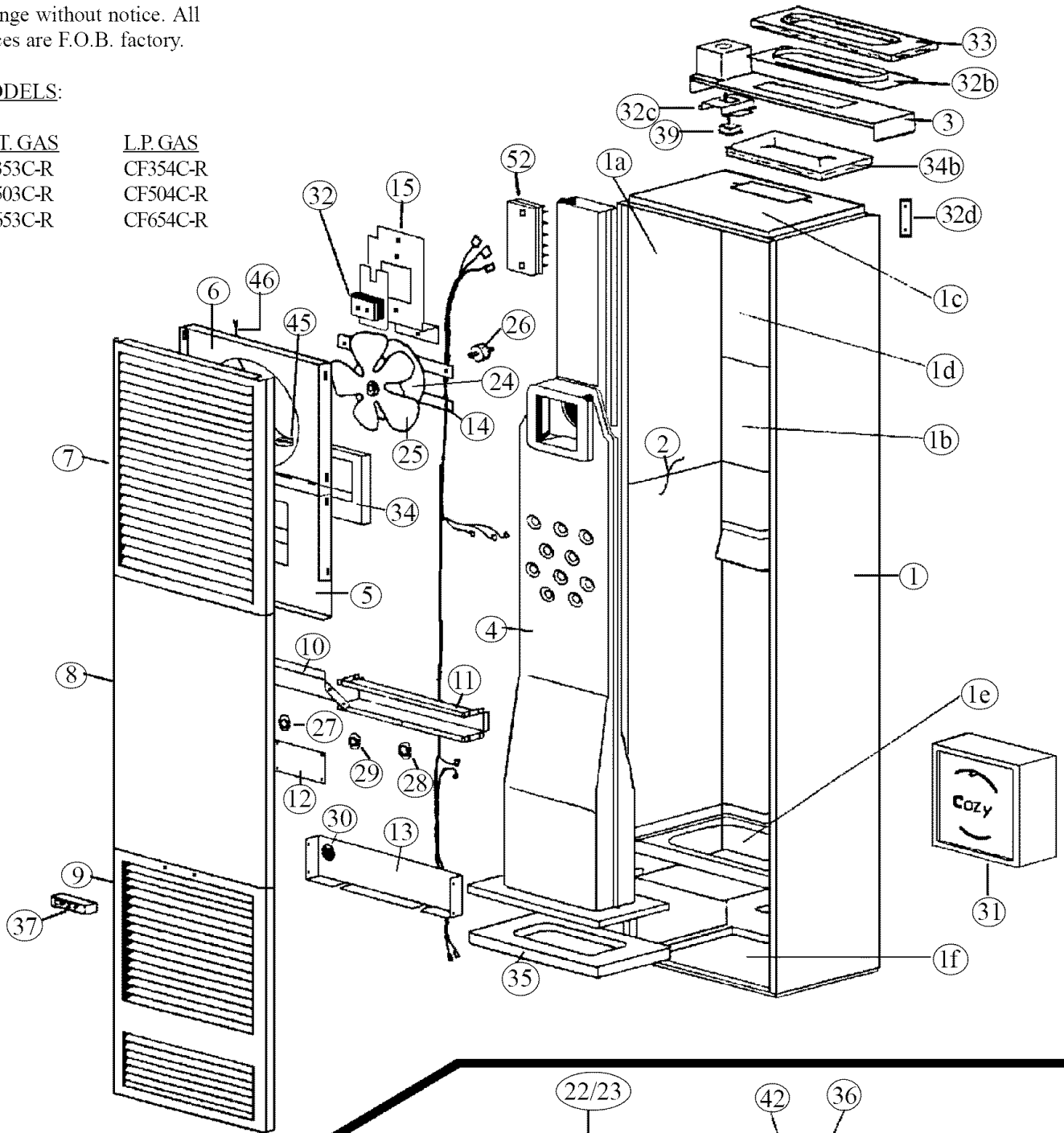

CONTROL ASSEMBLY

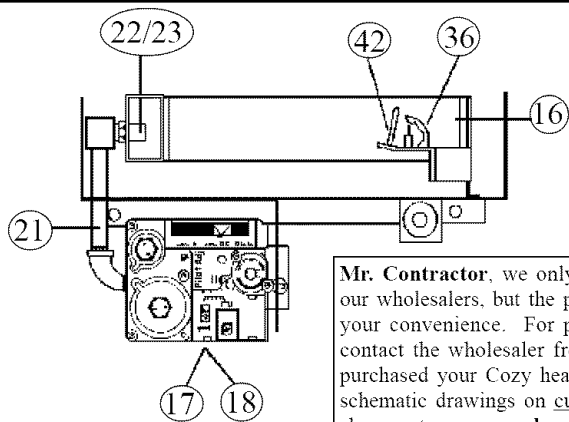

Mr. Contractor, we only sell parts through our wholesalers, but the prices listed are for your convenience. For prompt parts service, contact the wholesaler from which you purchased your Cozy heater. NOTE: Parts & schematic drawings on current models are shown at www.cozyheaters.com.

HOW TO PROPERLY ORDER PARTS: In addition to part description and part number, please give model number, serial number, and type of gas used. This information can be found on the rating plate that is attached to heater.

24 VOLT SYSTEM WITH LOW-B.T.U. STANDING PILOT							
MODEL NUMBER	NATURAL	CF353C-R		CF503C-R		CF653C-R	
	L.P.	CF354C-R		CF504C-R		CF654C-R	
PART DESCRIPTION	REF. NUMBER	PART NUMBER	LIST PRICE	PART NUMBER	LIST PRICE	PART NUMBER	LIST PRICE
Casing Side, Right	1	30055	\$48.40	30325	\$49.00	30525	\$52.10
Casing Side, Left	1a	30060	\$48.40	30330	\$49.00	30530	\$52.10
Center Back Assembly	1b	30114	\$37.10	30364	\$34.20	30544	\$36.80
Top Assembly	1c	30025	\$13.30	30025	\$13.30	30025	\$13.30
Upper Back Assembly	1d	30070	\$22.30	30070	\$22.30	30070	\$22.30
Lower Back Assembly	1e	30219	\$30.60	30219	\$30.60	30219	\$30.60
Bottom	1f	30246	\$9.80	30246	\$9.80	30246	\$9.80
Liner Assembly	2	30120	\$73.30	30370	\$74.00	30550	\$80.20
Header Assembly Complete	3	31399	\$38.60	31399	\$38.60	31399	\$38.60
Heat Exchanger Assembly	4	30133	\$210.60	30379	\$216.10	30563	\$216.10
Draft Diverter Assembly	5	30180	\$31.30	30400	\$42.30	30400	\$42.30
Fan Shroud Assembly	6	30200	\$21.60	30200	\$21.60	30200	\$21.60
Top Louver w/Insulation	7	30087	\$17.60	30087	\$17.60	30087	\$17.60
Center Front Panel w/Insulation	8	30089	\$24.90	30359	\$26.70	30534	\$28.80
Bottom Louver Assembly w/Insulation	9	30100	\$31.60	30100	\$31.60	30100	\$31.60
Upper Front Shield	10	30250	\$3.50	30250	\$3.50	30250	\$3.50
Switch Box	11	30252	\$7.10	30450	\$7.20	30450	\$7.20
Switch Box Cover	12	30253	\$2.80	30253	\$2.80	30253	\$2.80
Lower Front Shield	13	30256	\$5.10	30256	\$5.10	30256	\$5.10
Motor Mounting Bracket	14	* 30079	\$2.10	*30079	\$2.10	*30079	\$2.10
Junction Box Cover	15	30033	\$3.70	30033	\$3.70	30033	\$3.70
Burner	16	72107	\$38.20	72107	\$38.20	72107	\$38.20
Valve, 7200ERSO4 NATURAL GAS	17	72090	\$137.90	72090	\$137.90	72090	\$137.90
Valve, 7200ERSO4 L.P. GAS	18	72091	\$137.90	72091	\$137.90	72091	\$137.90
Manifold	21	78006	\$12.30	78006	\$12.30	78006	\$12.30
Orifice,NATURAL	22	72182	\$3.40	78160	\$3.40	78169	\$3.40
Orifice, L.P.	23	95271	\$3.40	78163	\$3.40	95273	\$3.40
Fan Motor	24	72108	\$73.90	78111	\$85.80	78111	\$85.80
Fan Blade	25	78101	\$24.20	78101	\$24.20	78101	\$24.20
Rubber Grommet	26	78010	\$3.00	78010	\$3.00	78010	\$3.00
Limit Switch 60T11-L180	27	78065	\$5.90	78065	\$5.90	78065	\$5.90
Fan Switch 60T12-F120	28	78067	\$6.10	78067	\$6.10	78067	\$6.10
Speed Switch 60T13-F160-30	29	N/A	N/A	78066	\$8.90	78066	\$8.90
Auxiliary Limit Switch 60T15-L350	30	78086	\$9.30	78086	\$9.30	78086	\$9.30
Thermostat 24 Volt	31	78355	\$20.00	78355	\$20.00	78355	\$20.00
Transformer	32	78069	\$23.50	78069	\$23.50	78069	\$23.50
Flue Pipe Adapter	32b	40061	\$2.00	40061	\$2.00	40061	\$2.00
Plug Bracket	32c	30047	\$1.90	30047	\$1.90	30047	\$1.90
Casing Mounting Brackets	32d	*30260	\$1.20	*30260	\$1.20	*30260	\$1.20
Flue Pipe Gasket	33	78050	\$1.20	78050	\$1.20	78050	\$1.20
Draft Diverter Gasket	34	78051	\$1.20	78051	\$1.20	78051	\$1.20
Casing Top Gasket	34b	78049	\$1.20	78049	\$1.20	78049	\$1.20
Element Support Gasket	35	78052	\$4.40	78052	\$4.40	78052	\$4.40
Pilot,NAT. 0.140.512	36	72020	\$22.70	72020	\$22.70	72020	\$22.70
Pilot, L.P. 0.140.502	36	72021	\$22.70	72021	\$22.70	72021	\$22.70
Cozy Handle	37	84003	\$2.30	84003	\$2.30	84003	\$2.30
Power Cord	38	78213	\$4.70	78213	\$4.70	78213	\$4.70
Snap-in Outlet	39	78058	\$4.70	78058	\$4.70	78058	\$4.70
Thermostat Wire	41	74518	\$1.30	74518	\$1.30	74518	\$1.30
Thermocouple Q309A-2135	42	78095	\$11.40	78095	\$11.40	78095	\$11.40
Insulated Staples	43	74209	\$1.20	74209	\$1.20	74209	\$1.20
Door Catch	44	80005	\$1.20	80005	\$1.20	80005	\$1.20
Blocked Flue Switch	45	78108	\$9.30	78109	\$9.30	78109	\$9.30
Blocked Flue Switch Wire	46	78230	\$1.50	78230	\$1.50	78230	\$1.50
Terminal Board	52	78300	\$5.00	78300	\$5.00	78300	\$5.00
Pilot Tubing w/Fittings	—	78452	\$5.40	78452	\$5.40	78452	\$5.40
Piezo Sparker	—	80016	\$5.70	80016	\$5.70	80016	\$5.70
Electrode Wire	—	72022	\$4.70	72022	\$4.70	72022	\$4.70
Burner Pan Assembly	53	30286	\$15.90	30286	\$15.90	30286	\$15.90
Valve Support Bracket Assembly	56	30290	\$4.70	30290	\$4.70	30290	\$4.70
Pilot Mounting Bracket	57	30299	\$2.40	30299	\$2.40	30299	\$2.40
Burner Mounting Plate	58	30296	\$2.80	30296	\$2.80	30296	\$2.80
Lighting Instructions "CF"	—	91272	N/C	91272	N/C	91272	N/C

COUNTERFLOW WALL FURNACE / I.I.D. PILOT

Prices and specifications subject to change without notice. All prices are F.O.B. factory.

MODELS:

NAT. GAS
CF357C-R
CF557C-R

L.P. GAS
CF358C-R
CF558C-R

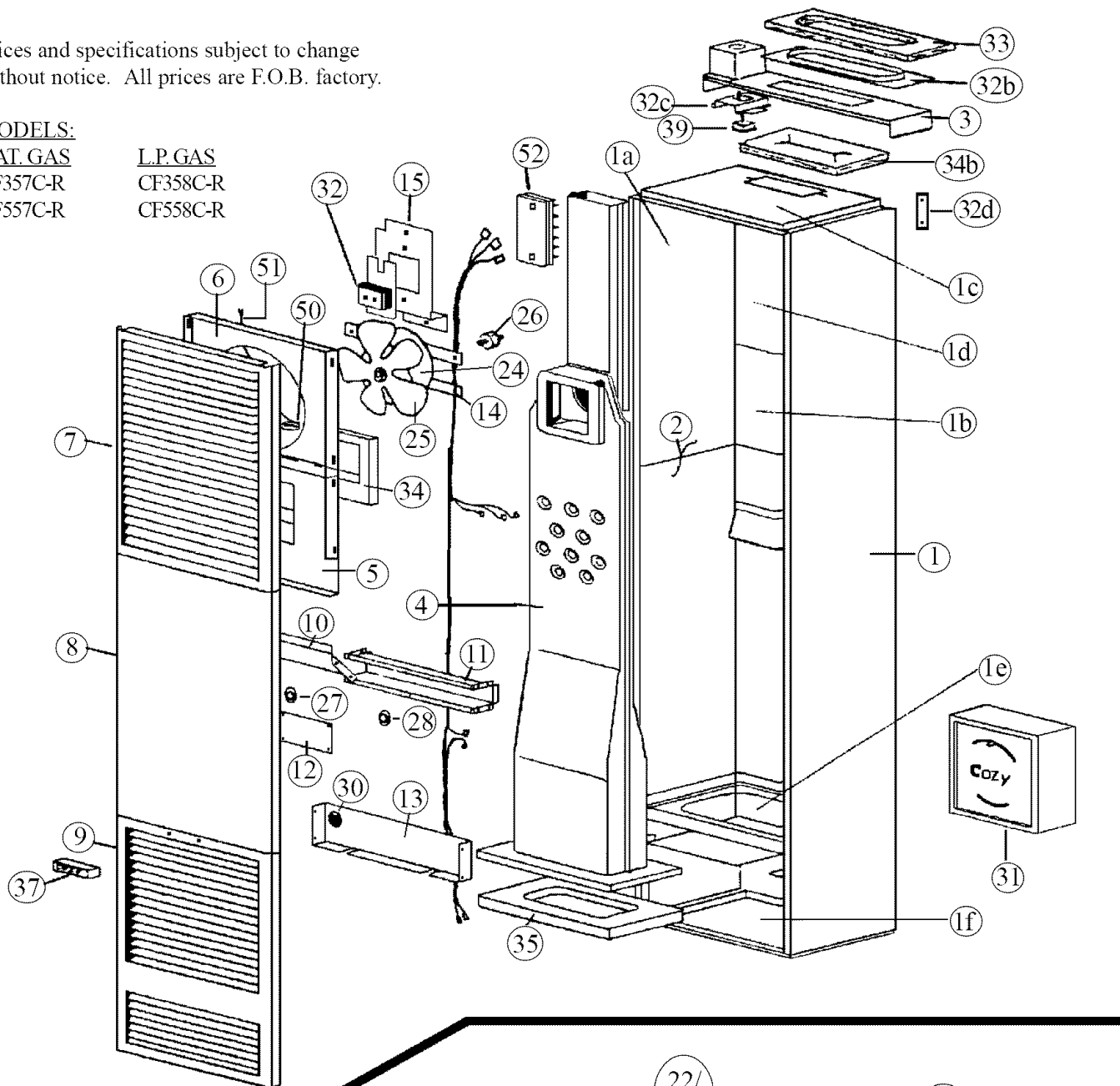

CONTROL ASSEMBLY

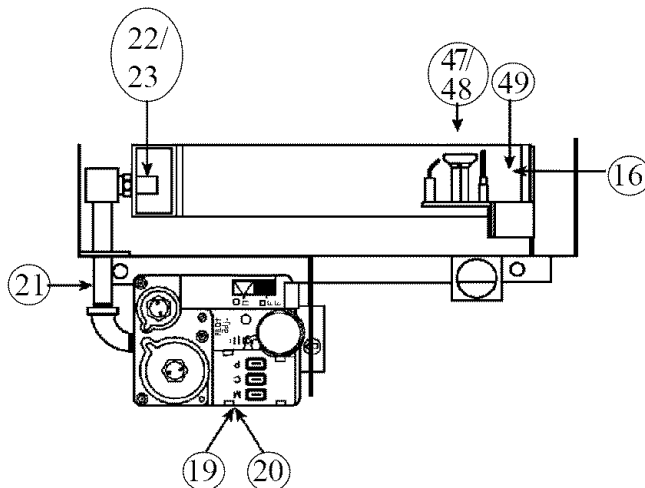
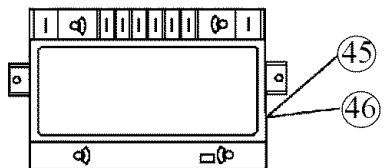

Mr. Contractor, we only sell parts through our wholesalers, but the prices listed are for your convenience. For prompt parts service, contact the wholesaler from which you purchased your Cozy heater. **NOTE:** Parts & schematic drawings on current models are shown at www.cozyheaters.com.

HOW TO PROPERLY ORDER PARTS: In addition to part description and part number, please give model number, serial number, and type of gas used. This information can be found on the rating plate that is attached to heater.

24 VOLT SYSTEM WITH INTERMITTENT

MODEL NUMBERS	NATURAL	CF357C-R		CF557C-R	
	L.P.	CF358C -R		CF558C-R	
PART DESCRIPTION	REF. NUMBER	PART NUMBER	LIST PRICE	PART NUMBER	LIST PRICE
Casing Side, Right	1	30055	\$48.40	30525	\$52.10
Casing Side, Left	1a	30060	\$48.40	30530	\$52.10
Center Back Assembly	1b	30114	\$37.10	30544	\$36.80
Top Assembly	1c	30025	\$13.30	30025	\$13.30
Upper Back Assembly	1d	30070	\$22.30	30070	\$22.30
Lower Back Assembly	1e	30219	\$30.60	30219	\$30.60
Bottom	1f	30246	\$9.80	30246	\$9.80
Liner Assembly	2	30120	\$73.30	30550	\$80.20
Header Assembly Complete	3	31399	\$38.60	31399	\$38.60
Heat Exchanger Assembly	4	30133	\$210.60	30562	\$217.20
Draft Diverter Assembly	5	30180	\$31.30	30400	\$42.30
Fan Shroud Assembly	6	30200	\$21.60	30200	\$21.60
Top Louver w/Insulation	7	30087	\$17.60	30087	\$17.60
Center Front Panel w/Insulation	8	30089	\$24.90	30534	\$28.80
Bottom Louver Assembly w/Insulation	9	30100	\$31.60	30100	\$31.60
Upper Front Shield	10	30250	\$3.50	30250	\$3.50
Switch Box	11	30252	\$7.10	30450	\$7.20
Switch Box Cover	12	30253	\$2.80	30253	\$2.80
Lower Front Shield	13	30256	\$5.10	30256	\$5.10
Motor Mounting Bracket	14	*30079	\$2.10	*30079	\$2.10
Junction Box Cover	15	30033	\$3.70	30033	\$3.70
Burner	16	72107	\$38.20	72107	\$38.20
Valve, NATURAL - I.L.D. 7200IPER	19	72092	\$129.00	72092	\$129.00
Valve, L.P. - I.L.D. 7200IPER	20	72093	\$129.00	72093	\$129.00
Manifold	21	78006	\$12.30	78006	\$12.30
Orifice, Natural	22	72182	\$3.40	78161	\$3.40
Orifice, L.P.	23	95271	\$3.40	78168	\$3.40
Fan Motor	24	72108	\$73.90	78111	\$85.80
Fan Blade	25	78101	\$24.20	78101	\$24.20
Rubber Grommet	26	78010	\$3.00	78010	\$3.00
Limit Switch	27	78065	\$5.90	78065	\$5.90
Fan Switch 60T12-F120	28	78067	\$6.10	78067	\$6.10
Speed Switch F160-30	29	N/A	N/A	78066	\$8.90
Auxiliary Limit Switch 60TG15 350 Deg., Lower	30	78086	\$9.30	78086	\$9.30
Thermostat	31	78355	\$20.00	78355	\$20.00
Transformer	32	78069	\$23.50	78069	\$23.50
Flue Pipe Adapter	32b	40061	\$2.00	40061	\$2.00
Plug Bracket	32c	30047	\$1.90	30047	\$1.90
Casing Mounting Brackets	32d	*30260	\$1.20	*30260	\$1.20
Flue Pipe Gasket	33	78050	\$1.20	78050	\$1.20
Draft Diverter Gasket	34	78051	\$1.20	78051	\$1.20
Casing Top Gasket	34b	78049	\$1.20	78049	\$1.20
Element Support Gasket	35	78052	\$4.40	78052	\$4.40
Cozy Handle	37	84003	\$2.30	84003	\$2.30
Power Cord	38	78213	\$4.70	78213	\$4.70
Snap-in Outlet	39	78058	\$4.70	78058	\$4.70
Thermostat Wire	41	74518	\$1.30	74518	\$1.30
Ignition Control Box, NAT., SP715A	45	78070	\$104.50	78070	\$104.50
Ignition Control Box, L.P., SP845	46	78088	\$143.30	78088	\$143.30
Pilot Assembly, Electronic, NAT., 3S-24	47	72098	\$37.30	72098	\$37.30
Pilot Assembly, Electronic, L.P., 3S-24	48	72097	\$33.70	72097	\$33.70
Pilot Bracket, CF-IID	—	30299	\$2.40	30299	\$2.40
Sensor, S1	49	78073	\$16.40	78073	\$16.40
Blocked Flue Switch	50	78108	\$9.30	78109	\$9.30
Blocked Flue Switch Wire	51	78230	\$1.50	78230	\$1.50
Terminal Board	52	78300	\$5.00	78300	\$5.00
Pilot Tubing w/Fitting	—	78452	\$5.40	78452	\$5.40
Burner Pan Assembly	53	30286	\$15.90	30286	\$15.90
Valve Support Bracket Assembly	56	30290	\$4.70	30290	\$4.70
Pilot Mounting Bracket	57	30299	\$2.40	30299	\$2.40
Burner Mounting Plate	58	30296	\$2.80	30296	\$2.80
Lighting Instructions "CF"	—	91261	N/C	91261	N/C

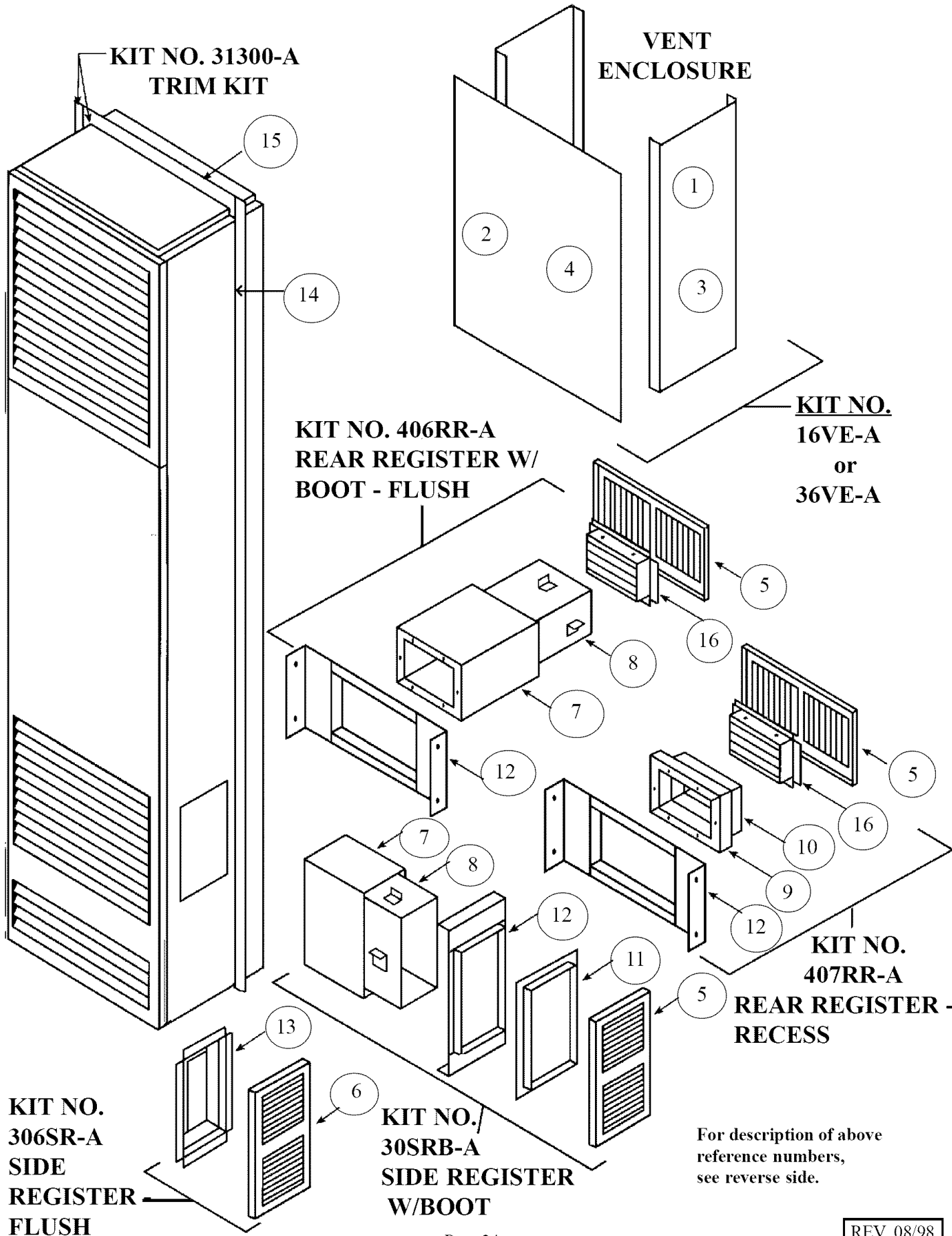

For description of above
reference numbers,
see reverse side.

PARTS LIST FOR ACCESSORIES FOR COUNTERFLOW WALL FURNACE

PART DESCRIPTION	REF. NO.	PART NO.	LIST PRICE
16" Vent Enclosure Side	1	31360	\$8.20
16" Vent Enclosure Front	2	31355	\$10.30
24" Vent Enclosure Side	1	31367	\$12.60
24" Vent Enclosure Front	2	31366	\$15.40
36" Vent Enclosure Side	3	31385	\$15.20
36" Vent Enclosure Front	4	31380	\$18.90
Side / Rear Register	5	31630	\$18.00
Side Register	6	31525	\$18.00
Large Outer Boot	7	31580	\$23.40
Large Inner Boot	8	31560	\$21.30
Small Outer Boot	9	31720	\$9.70
Small Inner Boot	10	31710	\$9.10
Boot Trim	11	31615	\$15.80
Plaster Ground	12	31595	\$11.60
Side Boot	13	31510	\$9.20
Cabinet Side Trim Angle	14	31310	\$5.30
Cabinet Top Trim	15	31320	\$4.60
Damper Assembly	16	31675	\$20.60

REPLACEMENT WIRING - STANDING PILOT COUNTERFLOW

MODELS CF353C-R & CF354C-R

Black 17-1/2" Fork Term./with Stripped end Transformer (24 V. Side) to The	78200	\$1.50
Black 27" Flag Terminal/Flag Terminal Auxiliary Limit Switch to Valve	78205	\$2.00
Wiring Harness	78250	\$23.50

MODELS CF503C-R & CF504C-R

Black 17-1/2" Fork Term./with stripped end Transformer (24 V.) to Therm	78200	\$1.50
Black 32" Flag Terminal/Flag Terminal Auxiliary Limit Switch - Valve	78216	\$1.90
Black 6" Flag Terminal/Flag Terminal Selector Switch - Fan Switch	78208	\$1.60
Wiring Harness	78251	\$23.50

MODELS CF653C-R & CF654C-R

Black 17-1/2" Fork Term./with stripped end Transformer (24 V.) to Therm	78200	\$1.50
Black 32" Flag Terminal/Flag Terminal Auxiliary Limit Switch - Valve	78216	\$1.90
Black 6" Flag Terminal/Flag Terminal Selector Switch to Fan Switch	78208	\$1.60
Wiring Harness	78252	\$23.50

REPLACEMENT WIRING - I.I.D. (INTERMITTENT IGNITION) COUNTERFLOW

MODELS CF357C-R & CF358C-R

Black 17-1/2" Fork Term./with stripped end Transformer (24V. Side) to Th	78200	\$1.50
Black 30" Flag Terminal/Straight Terminal Auxiliary limit to ignition control	78214	\$1.90
Wiring Harness	78259	\$23.50

MODELS CF557C-R & CF558C-R

Black 17-1/2" Fork Term./with stripped end Transformer (24V.) to Thermo	78200	\$1.50
Black 38" Flag Terminal/Straight Terminal Auxiliary limit to ignition control	78258	\$2.30
Black 6" Flag Terminal/Flag Terminal Selector Swith - Fan Switch	78208	\$1.60
Wiring Harness	78257	\$26.90

Mr. Contractor, we only sell parts through our wholesalers, but the prices listed are for your convenience. For prompt parts service, contact the wholesaler from which you purchased your Cozy heater. NOTE: Parts & schematic drawings on current models are shown at www.cozyheaters.com.

IMPORTANT SAFETY BULLETIN ON YOUR GAS CONTROL AND PILOT LIGHT SYSTEM FOR HEATING EQUIPMENT

WHAT YOU DON'T KNOW CAN HURT YOU.

Your pilot light system has been designed for safe and reliable operation. Although safety mechanisms are built-in, the potential for hazard exists. This information is intended to help you avoid these hazards.

YOUR GAS CONTROL AND PILOT LIGHT SYSTEM

Your gas control and pilot light system has a safety device whose purpose is to shut-off the gas supply to the appliance if the pilot light goes out. If you have trouble lighting the pilot or keeping it lit, it may mean that this safety device is warning you that there is a problem with your system. Inspection and repairs or replacement must be made by a trained gas service technician.



TAMPERING IS DANGEROUS

The pilot safety system may also not work if you do not follow the lighting instructions carefully or if you tamper with the gas control that you use to light the pilot. Tampering with the gas control, particularly with tools, can damage the safety mechanism in the control and can allow gas to leak. This can result in a fire or explosion causing property damage, personal injury or death.

IF YOU SMELL GAS, DON'T LIGHT IT

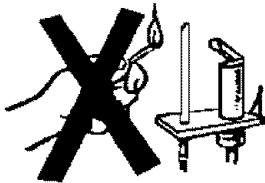

IF YOU CAN'T LIGHT IT,
DON'T FIGHT IT!



THIS IS NOT AN ADVERTISEMENT

WHAT TO DO IF YOU SMELL GAS . . .

- Do not try to light any appliance.
- Do not touch any electrical switch; do not use any phone in your building.
- Immediately call your gas supplier from a neighbor's phone. Follow the gas supplier's instructions.
- If you cannot reach your gas supplier, call the fire department.

Installation and service must be performed by a qualified installer, service agency or the gas supplier.

Do not store or use gasoline or other flammable vapors and liquids in the vicinity of this or any other appliance.

CRITICAL SAFETY POINTS TO REMEMBER . . .

- Your gas has been odorized so that you can smell it. Always smell around for gas before lighting your appliance.
- Sniff for L.P.-gas at floor level. LP-gas is heavier than air and may temporarily exist at floor level.



- If you smell gas, do not attempt to light the pilot. Do not cause a spark by turning on or off electrical switches or appliances or by using the phone. Turn off the gas to the appliances and call your gas supplier from another location.
- If your gas control has gotten wet as the result of flooding or other wetting, it must be replaced immediately by a trained gas service technician. Water can lead to damage of the internal safety mechanism in the gas control and can create a hazardous condition.

LIMITED WARRANTY

The Louisville Tin & Stove Co. warrants to the original user the accompanying product for the period specified herein, provided said product is installed, operated, maintained, serviced, and used according to the instructions and specifications accompanying the product. **AS OUTLINED IN OUR INSTRUCTIONS, ANY WARRANTY CONSIDERATIONS ARE CONTINGENT ON INSTALLATION BY A QUALIFIED INSTALLER (CONTRACTOR). SELF-INSTALLATION IS NOT RECOMMENDED AND MAY INVALIDATE YOUR WARRANTY.**

If within a period of one year from the date of installation of the product, any part supplied by the manufacturer proves to be defective due to workmanship or material, it will replace such part, provided parts have not been subjected to misuse, alteration, neglect, or accidents. The term of the warranty for the heat exchanger is covered in Table A below. Any claim not made within ten (10) days after the expiration of the warranty period shall be deemed waived by the user.

The manufacturer shall have no liability or be required to perform any obligation under this warranty unless, when requested, the user returns, at the user's expense, the component or product claimed defective, to the manufacturer for inspection, to enable the manufacturer to determine if the claimed defect is covered by this warranty.

No charges for freight, labor or other expenses incurred in the repair, removal, or replacement of any product or component claimed to be defective, will be paid by the manufacturer to the user, and the manufacturer will not be liable for any expenses incurred, by the user, in remedying any defect in the product.

Service under this warranty is the responsibility of the installer. In the event service under this warranty is needed, the user of the product

shall request such service directly from the installer. If the user is unable to locate the installer, the user should write directly to the manufacturer, and the name of an alternative service source will be supplied.

The product safety registration card (packed inside the appliance) must be completed and returned to the factory.

THIS WARRANTY IS EXPRESSLY IN LIEU OF ANY OTHER WARRANTIES, EXPRESS OR IMPLIED (WHETHER WRITTEN OR ORAL). ANY IMPLIED WARRANTY OF MERCHANTABILITY OR OF FITNESS FOR A PARTICULAR PURPOSE IS EXPRESSLY LIMITED TO THE DURATION OF THE MANUFACTURER'S EXPRESS, WRITTEN WARRANTY.

UNDER NO CIRCUMSTANCES SHALL THE MANUFACTURER BE LIABLE FOR ANY SPECIAL, INDIRECT OR CONSEQUENTIAL DAMAGES OR EXPENSES ARISING DIRECTLY OR INDIRECTLY FROM ANY COMPONENT OR FROM THE USE THEREOF. THE REMEDIES SET FORTH HEREIN SHALL BE THE EXCLUSIVE REMEDIES AVAILABLE TO THE USER AND ARE IN LIEU OF ALL OTHER REMEDIES.

SOME STATES DO NOT ALLOW LIMITATIONS ON HOW LONG AN IMPLIED WARRANTY LASTS, SO THE ABOVE LIMITATIONS MAY NOT APPLY TO YOU.

SOME STATES DO NOT ALLOW THE EXCLUSION OR LIMITATION OF INCIDENTAL OR CONSEQUENTIAL DAMAGES, SO THE ABOVE LIMITATIONS OR EXCLUSIONS MAY NOT APPLY TO YOU.

THIS WARRANTY GIVES YOU SPECIFIC LEGAL RIGHTS, AND YOU MAY ALSO HAVE OTHER RIGHTS, WHICH VARY, FROM STATE TO STATE.

TABLE A

Warranty for gas appliance heat exchangers only.

<u>Product</u>	<u>Warranty Period</u>
Cozy Gas Fired Floor Furnace	10 Years
Cozy Gas Fired Wall Furnace	10 Years
Cozy Gas Fired Vented Console Heater	10 Years
Cozy Gas Fired Direct Vent Heater	10 Years
Cozy Gas Fired Counterflow Furnace	10 Years
Cozy Gas Fired Counterflow Direct Vent Furnace	10 Years
Cozy Gas Fired Mobile Home Direct Vent Furnace	10 Years
Cozy Gas Fired Hi-Efficient Direct Vent Wall Furnace	10 Years

LOUISVILLE TIN AND STOVE COMPANY

P.O. Box 2767 - Louisville, Kentucky 40201-2767