

# GOZY

## GAS-FIRED VENTED WALL FURNACE



### INSTALLATION AND OPERATING INSTRUCTIONS

P/N 84502 / REV. 11/04



NATURAL GAS	W251F, W351F, W501F W255F, W355F, W505F	L.P. GAS	W252F, W352F, W502F W256F, W356F, W506F
----------------	--	-------------	--

**WARNING:** If the information in this manual is not followed exactly, a fire or explosion may result causing property damage, personal injury or loss of life.

- Do not store or use gasoline or other flammable vapors and liquids in the vicinity of this or any other appliance.
- **WHAT TO DO IF YOU SMELL GAS:**
  - Do not try to light any appliance.
  - Do not touch any electrical switch; do not use any phone in your building.
  - Immediately call your gas supplier from a neighbor's phone. Follow the gas supplier's instructions.
  - If you cannot reach your gas supplier, call the fire department.
- **INSTALLATION AND SERVICE MUST BE PERFORMED BY A QUALIFIED INSTALLER, SERVICE AGENCY OR THE GAS SUPPLIER.**

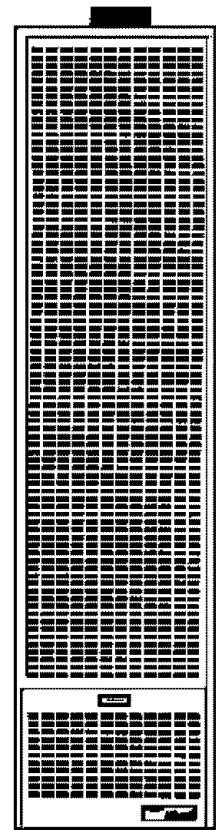

**WARNING:** Operation of this furnace when not connected to a properly installed and maintained venting system can result in Carbon Monoxide (C.O.) poisoning and possible death. For your safety, this furnace and the venting system should be inspected at least annually by a qualified service person.

This appliance is equipped with a blocked flue switch designed to protect against a blocked flue condition.

The coating selected to provide longer life to the heat exchanger may smoke slightly upon initial firing. Please provide adequate ventilation if this occurs.

This heater may be installed without recessing into stud space by using optional FSK (Free Standing Kit).

This unit is not approved for installation in mobile homes, greenhouses, or environments involving dusty, wet, corrosive, or explosive conditions. Such conditions will invalidate the warranty and may create unsafe conditions.

**THIS UNIT IS NOT TO BE INSTALLED IN MOBILE HOMES.**

## CONTENTS

Introduction.....	2	Rear Register Kit Instructions.....	9
Specifications.....	2	Lighting Instructions.....	10/11
Safety Rules.....	3	Pilot Adjustment.....	12
Clearances.....	3	Burner Flame Adjustment.....	12
Controls.....	3	Maintenance Instructions.....	12
Combustion & Ventilation Air.....	4	WFF81 Fan Instructions.....	13/14
Venting.....	5,6	Trouble Shooting Chart.....	15/16
Rough-In Instructions.....	6	Parts Drawing.....	17
Installation.....	8	Parts List.....	18
Wiring Instructions.....	9	Warranty.....	20

### READ CAREFULLY BEFORE INSTALLING UNIT

These installation instructions are a general guide, and do not supersede applicable local codes and ordinances. Before planning or making the installation, be sure it complies with all phases of the local heating codes. Or, in the absence of local codes, with the latest edition of the National Fuel Gas Code, ANSI.Z223.1. In Canada, see the current installation code CAN1-B149.

The appliance, when installed, must be electrically grounded in accordance with local codes or, in the absence of local codes, with the latest edition of the National Electrical Code ANSI/NFPA No. 70. In Canada, see the current Canadian Electrical Code C5AC22.1.

The ANSI standards are available from the American Gas Association, 1515 Wilson Blvd., Arlington, Virginia 22209.

The NFPA standards are available from the National Fire Protection Association, Batterymarch Park, Quincy, MA. 02269.

Canadian standards are available from International Approval Services, 178 Rexdale Blvd., Etobicoke, Ontario, Canada M9W 1R3.

NOTE: If optional rear register kit is to be used, see supplemental installation instructions (No. 84504) and section marked "Special Instructions for Rear Register Kit Application" prior to installation of Rough-In.

## INTRODUCTION

THIS IS A GAS-FIRED, GRAVITY VENTED WALL FURNACE THAT WILL OPERATE SAFELY AND PROVIDE AN EFFICIENT SOURCE OF HEAT WHEN INSTALLED, OPERATED AND MAINTAINED AS RECOMMENDED IN THESE INSTALLATION AND OPERATING INSTRUCTIONS. READ THESE INSTRUCTIONS THOROUGHLY BEFORE INSTALLING, SERVICING, OR USING THE APPLIANCE. IF YOU DO NOT UNDERSTAND ANY PART OF THESE INSTRUCTIONS, CONSULT LOCAL AUTHORITIES, OTHER QUALIFIED INSTALLERS, SERVICE AGENCIES, THE GAS SUPPLIER OR THE MANUFACTURER.

## SPECIFICATIONS

Your vented wall furnace comes packed in a single carton. (For wall thermostat models that includes the thermostat, thermostat wire, and insulated staples). Before installing the wall furnace check the rating plate to verify that the Model Number is correct and that the wall furnace is equipped for the type gas you intend to use.

Model No.	Type Control	Type Gas	BTU/Hr. Input	Vent Size	Gas Inlet	FINISHED DIMENSIONS	Shpg. Wt.	REAR REG. KIT		FAN KIT	
								Model	Weight	Model	Wt.
<b><u>SINGLE WALL FURNACE</u></b>											
W251F	Snap Bulb	Nat.	25,000	4"	1/2"	16-1/2"Wx68"Hx6-1/2"D	90 Lbs.	40542	5 Lbs.	WFF81	10 lbs.
W255F	Wall Stat	Nat.	25,000	4"	1/2"	16-1/2"Wx68"Hx6-1/2"D	90 Lbs.	40542	5 Lbs.	WFF81	10 lbs.
W252F	Snap Bulb	L.P.	25,000	4"	1/2"	16-1/2"Wx68"Hx6-1/2"D	90 Lbs.	40542	5 Lbs.	WFF81	10 lbs.
W256F	Wall Stat	L.P.	25,000	4"	1/2"	16-1/2"Wx68"Hx6-1/2"D	90 Lbs.	40542	5 Lbs.	WFF81	10 lbs.
W351F	Snap Bulb	Nat.	35,000	4"	1/2"	16-1/2"Wx68"Hx6-1/2"D	90 Lbs.	40542	5 Lbs.	WFF81	10 lbs.
W355F	Wall Stat	Nat.	35,000	4"	1/2"	16-1/2"Wx68"Hx6-1/2"D	90 Lbs.	40542	5 Lbs.	WFF81	10 lbs.
W352F	Snap Bulb	L.P.	35,000	4"	1/2"	16-1/2"Wx68"Hx6-1/2"D	90 Lbs.	40542	5 Lbs.	WFF81	10 lbs.
W356F	Wall Stat	L.P.	35,000	4"	1/2"	16-1/2"Wx68"Hx6-1/2"D	90 Lbs.	40542	5 Lbs.	WFF81	10 lbs.
<b><u>DUAL WALL FURNACE</u></b>											
W501F	Snap Bulb	Nat.	50,000	4"	1/2"	16-1/2"Wx68"Hx6-1/2"D	134 Lbs.	N/A	N/A	WFF81	10 lbs.
W505F	Wall Stat	Nat.	50,000	4"	1/2"	16-1/2"Wx68"Hx6-1/2"D	134 Lbs.	N/A	N/A	WFF81	10 lbs.
W502F	Snap Bulb	L.P.	50,000	4"	1/2"	16-1/2"Wx68"Hx6-1/2"D	134 Lbs.	N/A	N/A	WFF81	10 lbs.
W506F	Wall Stat	L.P.	50,000	4"	1/2"	16-1/2"Wx68"Hx6-1/2"D	134 Lbs.	N/A	N/A	WFF81	10 lbs.

One or two fan kits may be used on dual-wall furnace.

## SAFETY RULES

- A) The wall furnace should be located near the center of the house for best heat distribution.
- B) Due to high temperatures, the appliance should be located out of traffic and away from furniture and draperies.
- C) Children and adults should be alerted to the hazards of high surface temperature and should stay away to avoid burns or clothing ignition.
- D) Young children should be carefully supervised when they are in the same room as the appliance.
- E) Do not place clothing or other flammable material on or near the appliance. Precautions should be taken so as not to place furniture, drapes, or other articles directly in front of grille or lower access door that would obstruct air openings as proper air flow is critical to proper operation of unit.
- F) Any safety screen guard or casing front removed for servicing an appliance must be replaced prior to operating the appliance.
- G) If the area where the appliance is to be installed contains carpeting, tile or combustible materials, other than wood flooring, the appliance shall be installed on a metal plate, a wood panel or other non-combustible materials. The use of ceramic or quarry tile is acceptable and will provide a surface that is easily cleaned. This material is to extend the full width and depth of the appliance.

## CLEARANCES

As viewed from front of heater, the minimum clearance from cabinet to combustible construction: Side Wall – 1”;  
Floor – 2”;  
Ceiling – 11”.

In selecting a location for installation it is necessary to provide adequate accessibility clearances for servicing and proper operation. This appliance must not be connected to a chimney flue that serves to vent a solid-fuel burning (wood or coal) appliance, or a multi-vent system.

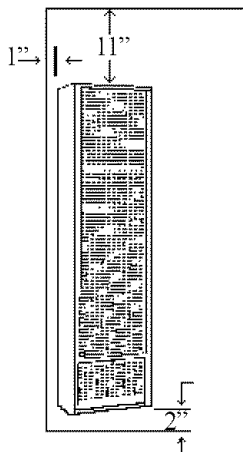

## CONTROLS

All controls are preassembled at the factory. If integral snap-bulb type thermostat is used, make sure that sensing bulb is located on the bottom of gas valve with clips provided. **DO NOT KINK** the connecting tubing. Do not bend the capillary bulb.

The normal manifold pressure should be 3.5” w.c. on Natural Gas and 10” w.c. on L.P. Gas. The maximum inlet pressure in the gas supply pipe should never exceed 14” w.c. on L.P. Gas or 7.0” w.c. on Natural Gas.

The appliance and its individual shutoff valve must be disconnected from the gas supply piping system during any pressure testing of that system at test pressures in excess of ½ psig.

The appliance must be isolated from the gas supply piping system by closing its individual manual shutoff valve during any pressure testing of the gas supply piping system at test pressures equal to or less than ½ psig.

The minimum inlet pressure in the gas supply pipe should be 5.0” w.c. on Natural Gas or 11” w.c. on L.P. Gas, “for purpose of input adjustment”.

The appliance is orificed at the factory for elevations up to 2,000 feet. If installed above 2,000 feet, the BTU input must be reduced 4% per 1,000 feet. See the following orifice chart for the proper orifice for a specific elevation. A blank orifice is shipped in the high altitude kit which will have to be drilled to correct size by installer, gas supplier or qualified serviceman.

### NATURAL GAS

Model No.	0 to 2,000'	2,000 - 4,000'	4,000 - 6,000'	6,000 - 8,000'	8,000 - 10,000'
W251F	43	44	45	47	48
W255F	43	44	45	47	48
W351F	36	38	40	41	43
W355F	36	38	40	41	43

ORDER KIT #49820 45-1 HIGH ALTITUDE KIT

W501F	43	44	45	47	48
W505F	43	44	45	47	48

ORDER KIT #49850 2287-2 HIGH ALTITUDE KIT

### L.P. GAS

Model No.	0 to 2,000'	2,000 - 4,000'	4,000 - 6,000'	6,000 - 8,000'	8,000 - 10,000'
W252F	1.45mm 54	54	55	55	
W256F	1.45mm 54	54	55	55	
W352F	52	52	53	54	
W356F	52	52	53	54	

ORDER KIT #49820 45-1 HIGH ALTITUDE KIT

W502F	1.45mm 54	54	55	55	
W506F	1.45mm 54	54	55	55	

ORDER KIT #49850 2287-2 HIGH ALTITUDE KIT

## COMBUSTION AND VENTILATION AIR

When installed, this gas appliance must be provided with fresh air for combustion, ventilation, and dilution of hot flue gases. The minimum required volume of the area where the appliance is installed should be 50 cubic feet per 1,000 btu/hr.

If installed in an area of the home that is considered an unconfined space, the natural infiltration of air around windows and doors will be adequate. If the area is considered a confined space (less than 50 cubic feet per 1,000 btu), fresh air can be supplied by providing two permanent openings into adjoining rooms. Each opening shall have a minimum free area of one square inch per 1,000 btu per hour of the total input rating of all gas appliances in the confined space, but not less than 100 square inches. One of the openings shall be within 12 inches of the ceiling and one within 12 inches of the floor. See Figure A.

If the home is of unusually tight construction (new and remodeled homes), free air must be supplied through opening(s) to the outdoors. This can be accomplished by providing 2 permanent openings, one commencing within 12 inches of the ceiling and one within 12 inches of the floor. These openings shall communicate directly with the outdoors, or spaces that communicate freely with the outdoors, such as a ventilated attic and crawl space through galvanized or equivalent corrosion-resistant ducts. Exception: unobstructed stud and joist spaces are acceptable ducts provided that not more than one fire block is removed. Special provisions must be taken to insure that these stud and joist spaces cannot be blocked with insulation or other objects. Each of these openings using vertical ducts shall have a minimum free area of one square inch per 4,000 btu/hr of total input rating of all gas appliances. See Figure B and C. If horizontal ducts are used, the minimum free area shall be one square inch per 2,000 btu/hr of total input rating of all gas appliances.

Fresh make-up air can also be provided through a duct to one permanent opening commencing within 12 inches of the ceiling. The minimum free area of this opening shall be one square inch per 3,000 btu/hr of the total input rating of all gas appliances but not less than the sum of the areas of all vent connectors in the space. See Figure D.

When calculating the amount of fresh air needed you must include make-up air requirements for the operation of exhaust fans, kitchen ventilation systems, clothes dryers, and fireplaces.

Additional information can be found in the latest edition of ANSI Z223.1 (National Fuel Gas Code).

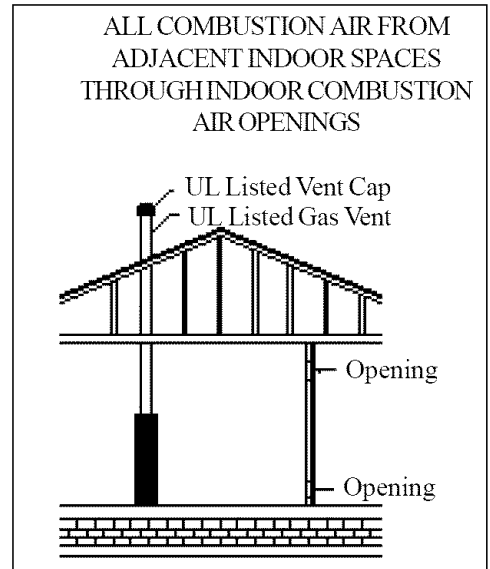

FIGURE A

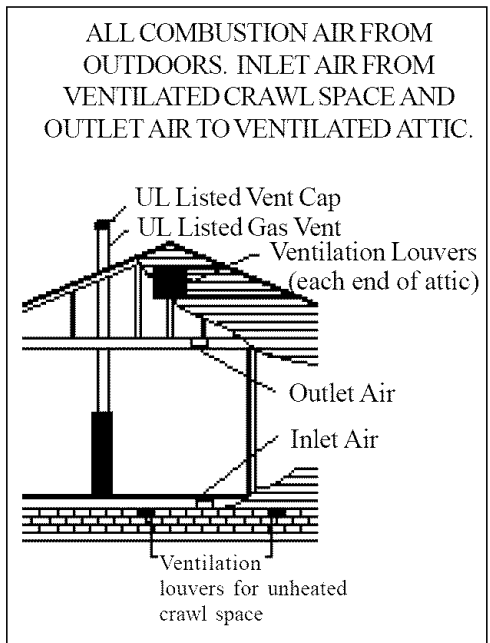

FIGURE B

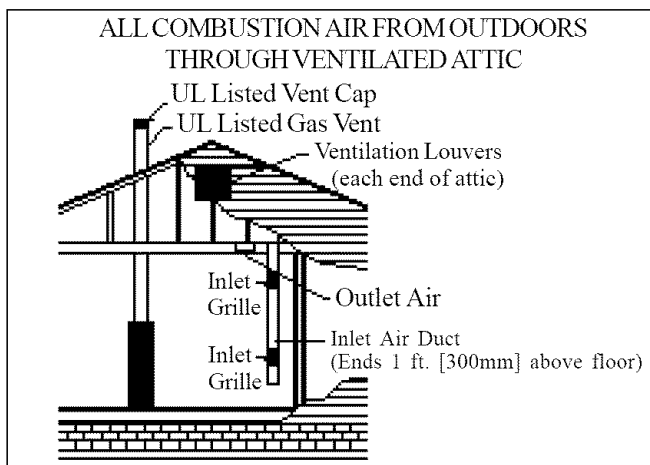

FIGURE C

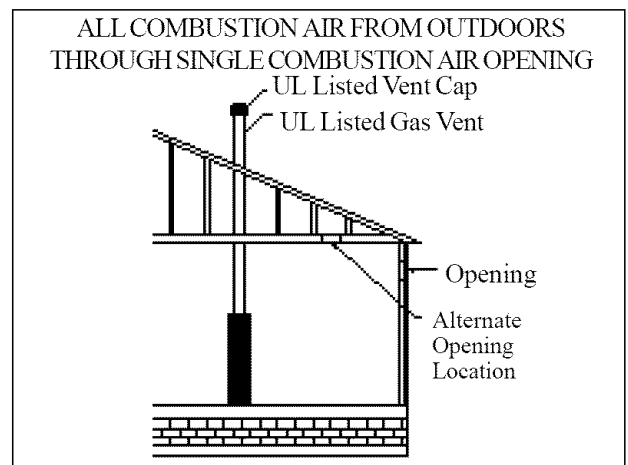
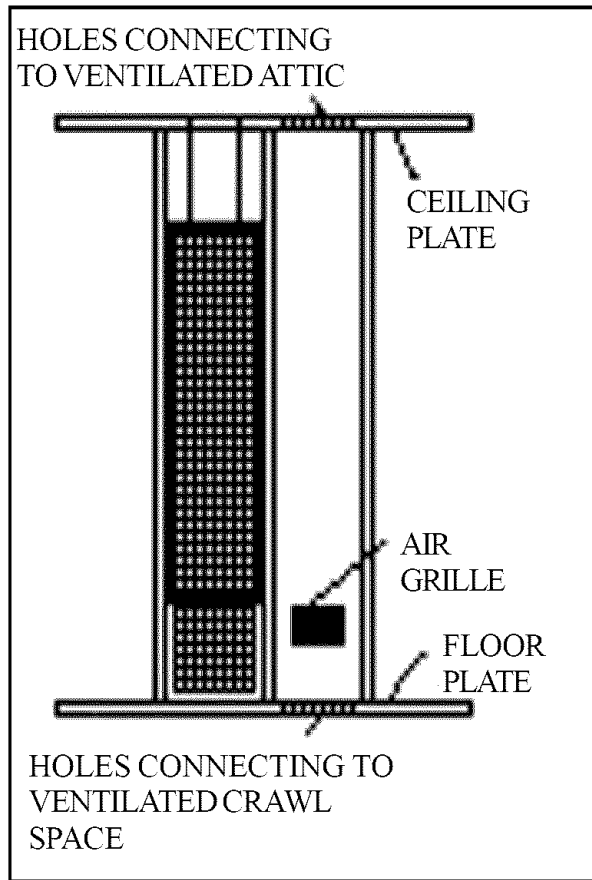

FIGURE D

**USING ADJACENT STUD SPACE  
FOR ALL COMBUSTION AIR  
FROM OUTSIDE**



BASED ON 4,000 BTU OF TOTAL INPUT RATING OF ALL GAS APPLIANCES, THE HEATER ONLY REQUIRES A MINIMUM FREE AREA OF:

BTU	SQUARE IN.	HOLE SIZE =	SQUARE IN.
25,000	6.25	1"	.785
35,000	8.75	1.5"	1.76
50,000	12.50	2"	3.14

**VENTING**

This appliance must be properly connected to a venting system.

Consult local ordinances governing venting. Install only UL listed type BW 4" oval gas vent. When the vent enters the attic, a listed type B-1 round flue pipe may be used. See Figure 2, Page 7.

Vent pipe must connect to the wall furnace header plate with a "B" vent base plate and terminate with a cap at a point at least 12 foot above the bottom of the wall furnace, two feet above any obstacle within a 10 foot radius, and at least 3 foot above the roof.

Provisions must be made for adequate combustion and ventilation air.

This appliance is equipped with a manual reset blocked flue switch designed to protect against a blocked flue condition, which would cause combustion products to spill back into the living quarters. NOTE: A partially blocked, inadequate, or disconnected vent system may not activate the switch. Discoloration of the grille is an indication of a bad vent. If this occurs, the vent can be checked by a qualified serviceman using a draft gauge. After 15 minutes the gauge should read between -.02 up to -.04 inches w.c. Vent must be checked at the beginning of each heating season.

The switch when activated on a bulb control burner will extinguish the pilot flame, on a thermostat controlled burner, the thermostat circuit will be broken, turning off the main burner flame. Before the heater can be relit, the reset button must be activated. See Figure B for location of the manual reset blocked flue switch. To reset the switch, insert a slender rigid object (i.e. screwdriver) through the front panel louvers and push the reset button down. See Figure B-1. However, you may have to remove the front panel, then reset the switch and reinstall the front panel to relight heater. If homeowner experiences this problem, the vent system must be checked and corrected. NOTE: A pre-existing vent that has worked for years may not be adequate for todays design because of higher efficiency requirements that result in lower stack temperatures. See "Possible Causes and Corrective Action" on Page 16.

All type "B" vents shall extend in a generally vertical direction with offsets not exceeding 45 degrees, except that a vent system having not more than one 60 degree offset may be allowed.

Any angle greater than 45 degrees from the vertical is considered horizontal. The total horizontal run of a vent plus the horizontal vent connector shall be not greater than 75 percent of the vertical height of the vent.

Any offsets used should be as far above the drafthood as possible to allow a venting action to begin before any restriction is encountered.

**WARNING:** Do not bypass the blocked flue switch. To do so could expose the consumer to property damage, personal injury or possible death.

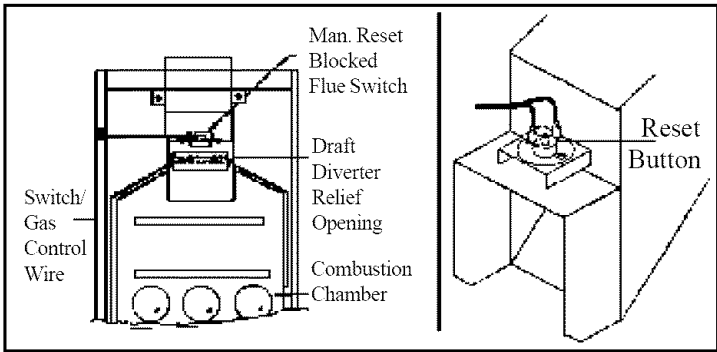
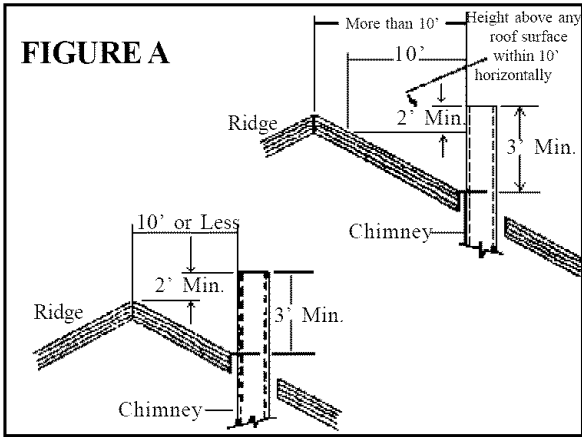

FIGURE B

FIGURE B-1

**ROUGH-IN INSTRUCTIONS**

NOTE: Maximum wall thickness for a dual wall (W501, W502, W505, W506) installation is 5-3/8".

**STEP 1.** Attach the base plate (purchased with the vent pipe) to the header plate using two No. 8 sheet-metal screws through the pre-punched holes. The heater may not vent properly without a base plate to anchor and seal the vent system. See Figure C.

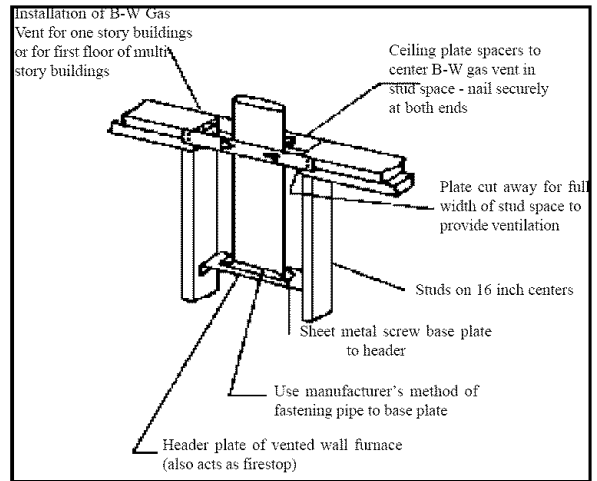
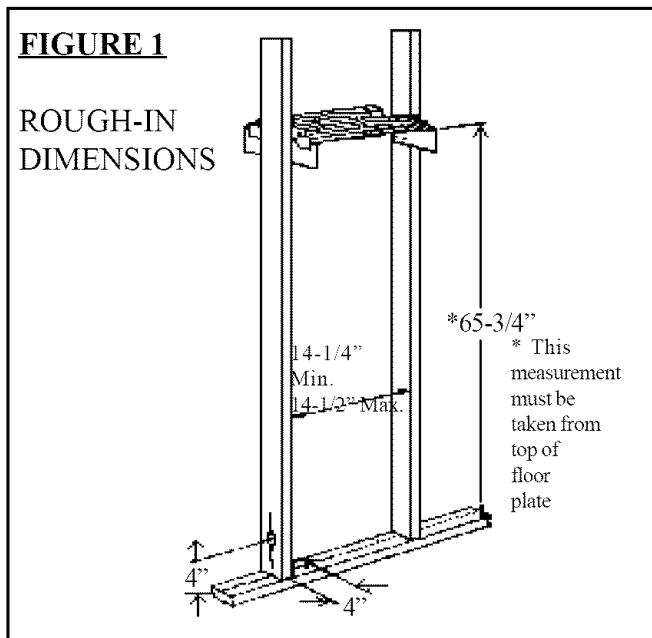

FIGURE C

**STEP 2.** Cut out an opening between the studs of 14-3/8" x 66-1/2" above the floor plate. Embed the rear flange of the channel on top of header into either the drywall or the plastered wall. This provides part of the required fire stop. Square up and nail the header in place with the top front of header located 65-3/4" above floor plate. (See arrow on right side of header and Figure 1, 5A and 5B on Page 7).

**STEP 3.** Rough in 1/2" gas supply on center line of left stud either 4" above top of floor plate or 4" to right of left stud through floor plate. See Figure 1 located on Page 7.

## ROUGH-IN INSTRUCTIONS



NOTE: For proper combustion, make sure units are level, front to back and side to side.

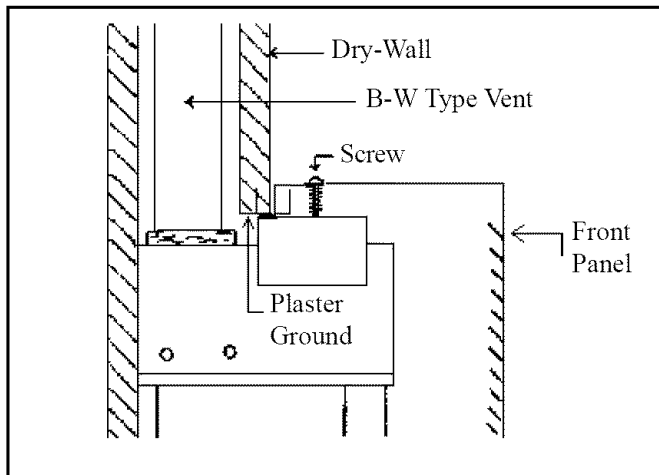

FIGURE 5A - DRY WALL

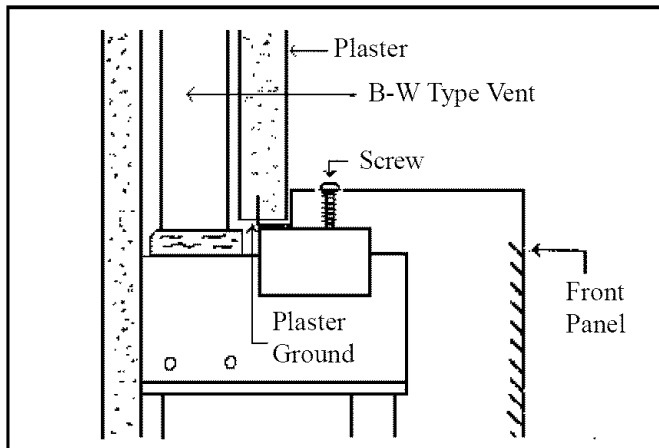

FIGURE 5B - PLASTER WALL

**STEP 4.** Remove double ceiling plate between studs. Install one ceiling plate spacer across the cut out in ceiling plate. Install vent pipe into position, be sure to lock bottom of vent pipe into the base plate. Nail second ceiling plate spacer in place. (See Figure C, Page 6).

**STEP 5.** If the vent continues through additional stories within the 2x4-stud space, then fire-stop-spacers must be installed at the second and subsequent ceiling levels. See Figure D.

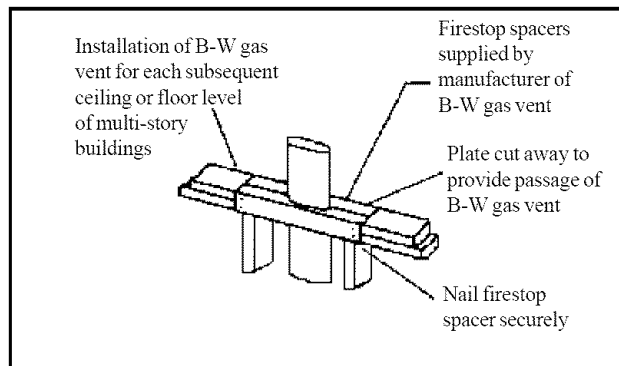

FIGURE D

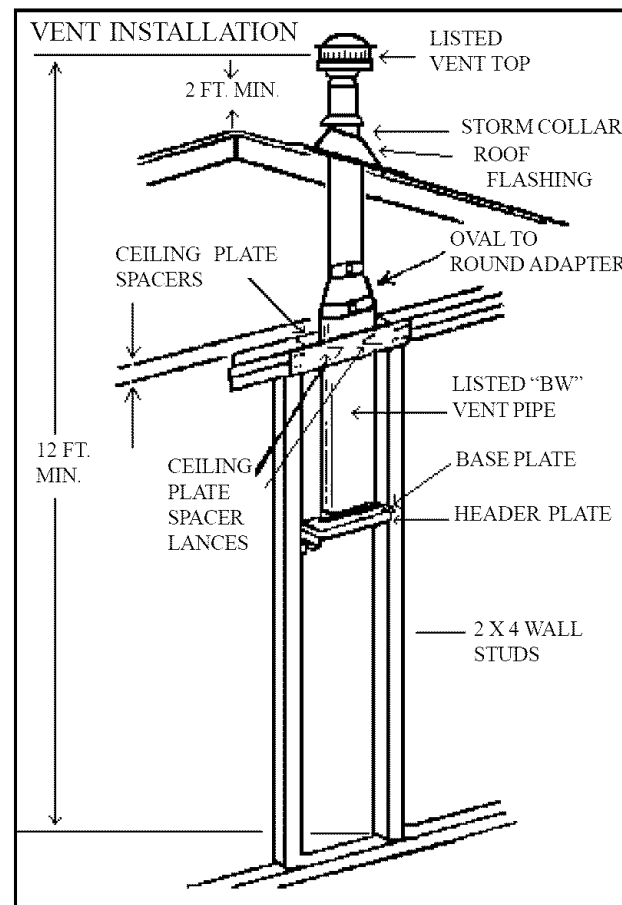

FIGURE 2 - VENT INSTALLATION

## INSTALLATION

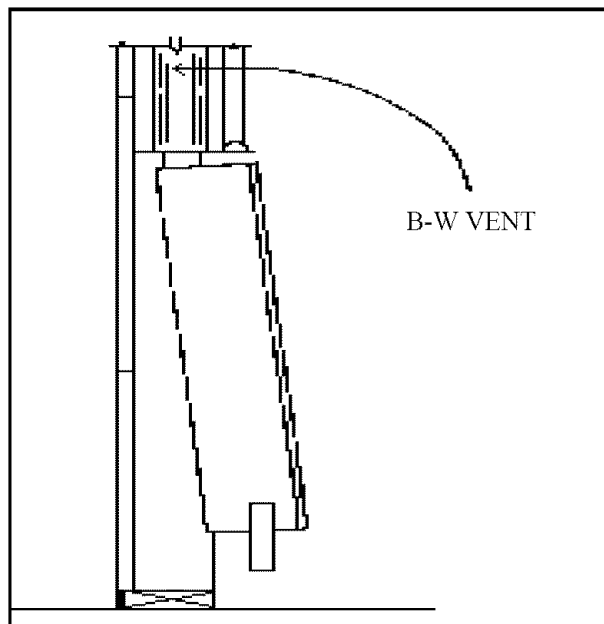

FIGURE 3

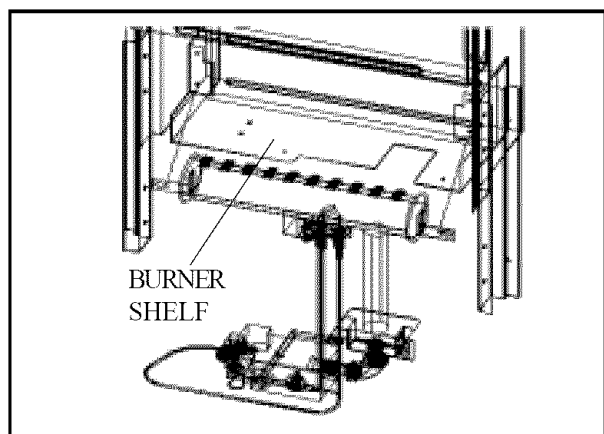

FIGURE 4

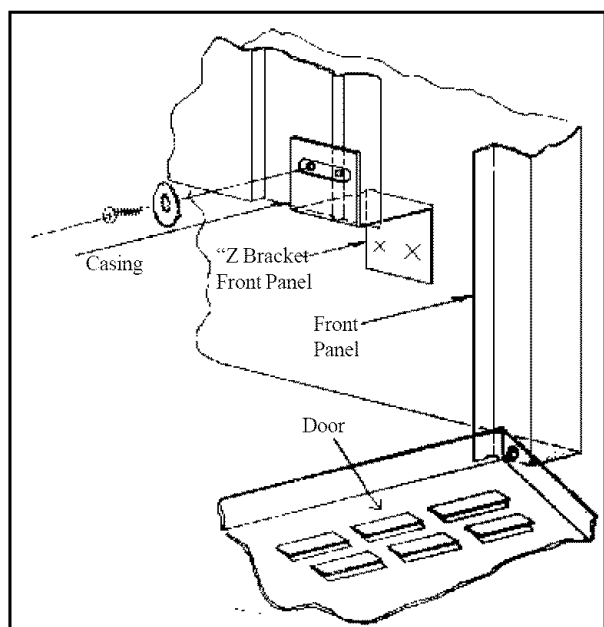

FIGURE 5C

**STEP 6.** To place furnace into position, grasp furnace and lift so furnace flue vent and header plate vent opening engage. Do not use burner or gas control to lift heater. Lift furnace upward and swing bottom into wall opening until legs rest on floor plate and are flush to finished wall. For proper combustion, level heater front to back and side to side. Nail legs to studs. **DO NOT BEND LEGS** as this will put the entire unit into a bind and cause expansion noises (See Figure 3).

**STEP 7.** A drip leg and a manual valve equipped with a 1/8 N.P.T. plugged tapping accessible for test gauge connection should be installed immediately upstream of the gas supply connection to the appliance. Some codes and ordinances require that the manual valve be located outside the appliance.

**STEP 8.** Make gas connection using connector the same size as gas connection of furnace. **CHECK ALL CONNECTIONS FOR GAS LEAKS WITH LEAK DETECTOR SOLUTION. DO NOT USE OPEN FLAME.**

**STEP 9.** For wall thermostat units, see “Wiring” section for thermostat connections. Make sure all connections are correct and connector stems are not touching.

**STEP 10.** To fasten front panel to furnace, be sure exposed portion of header is free of debris and plaster. Place outer panel over furnace with top of panel about one inch above header and centered in opening. Keep front panel flush to finished wall and slide down until rear flange of top outer panel is wedged tight with header and flush with wall. Open bottom door of front panel and place sheet metal screw into locking latch. Secure top of front panel to header plate with screw provided. This will hold front panel securely to wall. See Figures 5A, 5B, (See Page 7), and 5C.



**CAUTION:** Label all wires prior to disconnection when servicing controls. Wiring errors can cause improper and dangerous operation. Verify proper operation after servicing.

**WIRING INSTRUCTIONS –  
GRAVITY WALL FURNACE**

**WARNING:** Failure to locate the thermostat properly or to wire the furnace correctly may result in continuous operation, control damage or failure to operate. This can cause property damage, personal injury, or loss of life.

Follow the instructions included with the thermostat. Locate the thermostat approximately five (5) feet above the floor and four feet (4') from appliance. Always mount the thermostat on an inside wall where it won't be affected by heat or cold sources such as direct sunlight, televisions, fireplaces, hidden hot or cold water pipes, drafts, etc. The thermostat must never be installed in an adjoining room where a door can be closed between the thermostat and wall furnace. This wall furnace is equipped with a self generating control system. Never connect to a 24 volt transformer or to the household electrical system. Do not use more thermostat wire than is included with the wall furnace. Do not run thermostat wire in same stud space with vent. Conceal wire inside wall or secure to wall with insulated staples that are included .

**YOUR FURNACE MAY BE EQUIPPED WITH EITHER A WALL THERMOSTAT (Figure 2) OR SNAP-BULB, BUILT-IN THERMOSTAT (Figure 1) CONTROL. CHECK THE CONTROL ASSEMBLY TO DETERMINE WHICH WIRING EXAMPLE TO USE.**

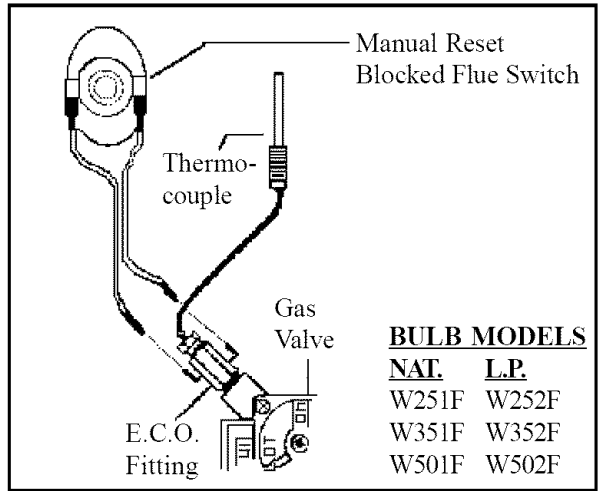

FIGURE 1

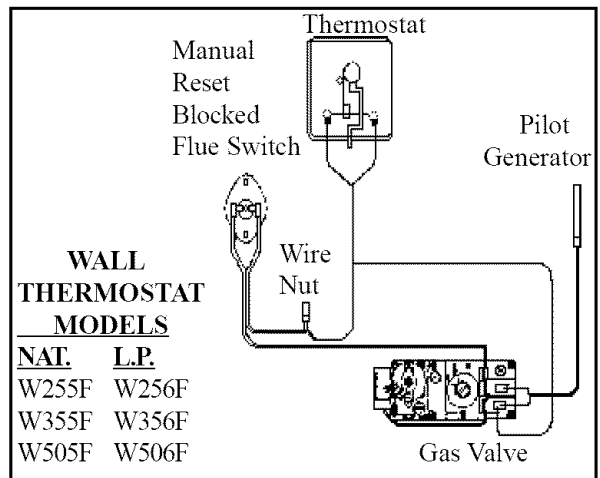

FIGURE 2

**SPECIAL INSTRUCTIONS FOR REAR REGISTER KIT APPLICATION**

(Figures 6 and 7 line drawings of rear register opening)

**STEP 1.** Cut hole in the back wall 8-1/4" high by 12-5/8" wide. The lower edge of the hole to be 45-3/4" above the floor plate as shown in Figure 6.

**STEP 2.** Install frame for rear register in hole and nail frame to stud as shown in Figure 7.

**STEP 3.** Install rough-in header and follow instructions for installation of regular furnace.

NOTE: See Supplement No. 84504 packaged with Rear Register Kit.

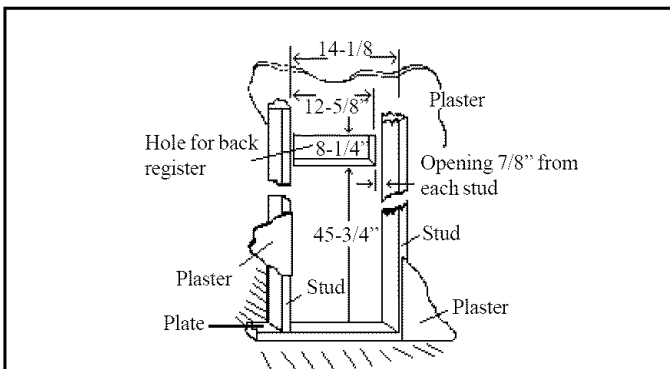

FIG. 6 - ROUGH-IN DIMENSION FOR REAR REGISTER

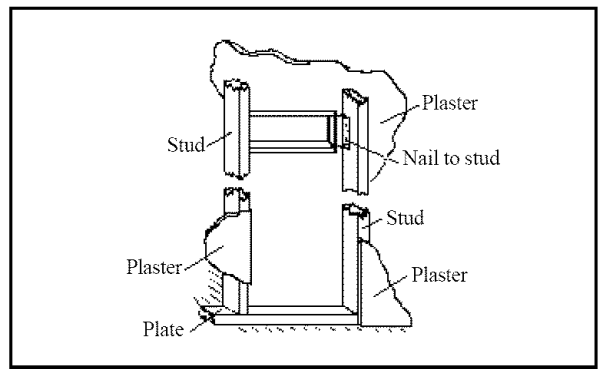

FIG. 7 - PLACING FRAME FOR REAR REGISTER

## LIGHTING INSTRUCTIONS

**MODELS: W255F, W256F / W355F, W356F / W505F, W506F**

### FOR YOUR SAFETY READ BEFORE LIGHTING

**WARNING: If you do not follow these instructions exactly, a fire or explosion may result causing property damage, personal injury or loss of life.**

- A. This appliance has a pilot which must be lighted by hand. When lighting the pilot, follow these instructions exactly.
- B. BEFORE LIGHTING smell all around the appliance area for gas. Be sure to smell next to the floor because some gas is heavier than air and will settle on the floor.
- WHAT TO DO IF YOU SMELL GAS:
- Do not try to light any appliance.
  - Do not touch any electric switch; do not use any phone in your building.
  - Immediately call your gas supplier from a neighbor's phone. Follow the gas supplier's instructions.
- If you cannot reach your gas supplier, call the fire department.
- C. Use only your hand to push in or turn the gas control knob. Never use tools. If the knob will not push in or turn by hand, don't try to repair it, call a qualified service technician. Force or attempted repair may result in a fire or explosion.
- D. Do not use this appliance if any part has been under water. Immediately call a qualified service technician to inspect the appliance and to replace any part of the control system and any gas control which has been under water.

## LIGHTING INSTRUCTIONS

1. STOP! Read the information on the safety label.
2. Set thermostat to it's lowest setting.
3. Open cabinet door.
4. Depress and turn gas control knob clockwise ↻ to "OFF".

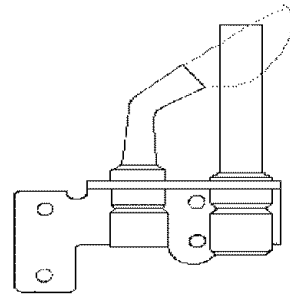
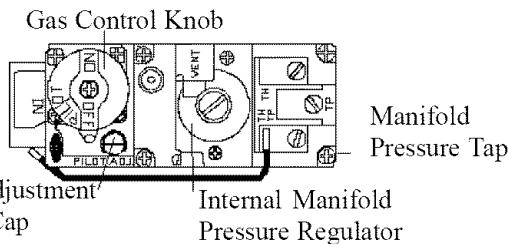

Pilot is located on side of burner

5. Wait five (5) minutes to clear out any gas. Then smell for gas, including near the floor. If you smell gas, STOP! Follow "B" in the information on the safety label. If you don't smell gas, go to the next step.
  6. Locate the pilot. (Follow metal pilot tube from gas control).
  7. Turn gas control knob counterclockwise ↶ to "PILOT".
  8. Push gas control knob and hold in. Immediately light the pilot with a match. Continue to hold the gas control knob in for about one (1) minute after the pilot is lit. Release gas control knob and it will pop back up. Pilot should remain lit. If pilot goes out, repeat steps 4 through 8.
  9. Turn gas control knob counterclockwise ↶ to "ON".
  10. Close the cabinet door.
  11. Set thermostat to desired setting.
- If knob does not pop up when released, STOP and immediately call your service technician or gas supplier.
  - If the pilot will not stay lit after several tries, turn the gas control knob to "OFF" and call your service technician or gas supplier.

## TO TURN OFF GAS TO APPLIANCE

1. Set the thermostat to it's lowest setting.
2. Open cabinet door.
3. Push in gas control knob slightly and turn clockwise ↻ to "OFF". Do not force.
4. Close cabinet door.

## LIGHTING INSTRUCTIONS

**MODEL: W251F, W252F / W351F, W352F / W501F, W502F**

### FOR YOUR SAFETY READ BEFORE LIGHTING

**WARNING: If you do not follow these instructions exactly, a fire or explosion may result causing property damage, personal injury or loss of life.**

- |  |  |
|--|--|
| <p>A. This appliance has a pilot which must be lighted by hand. When lighting the pilot, follow these instructions exactly.</p> <p>B. BEFORE LIGHTING smell all around the appliance area for gas. Be sure to smell next to the floor because some gas is heavier than air and will settle on the floor.</p> <p style="text-align: center;">WHAT TO DO IF YOU SMELL GAS:</p> <ul style="list-style-type: none"> <li>• Do not try to light any appliance.</li> <li>• Do not touch any electric switch; do not use any phone in your building.</li> <li>• Immediately call your gas supplier from a neighbor's phone. Follow the gas supplier's instructions.</li> </ul> | <ul style="list-style-type: none"> <li>• If you cannot reach your gas supplier, call the fire department.</li> </ul> <p>C. Use only your hand to push in or turn the gas control knob. Never use tools. If the knob will not push in or turn by hand, don't try to repair it, call a qualified service technician. Force or attempted repair may result in a fire or explosion.</p> <p>D. Do not use this appliance if any part has been under water. Immediately call a qualified service technician to inspect the appliance and to replace any part of the control system and any gas control which has been under water.</p> |
|--|--|

## LIGHTING INSTRUCTIONS

1. STOP! Read the information on the safety label.
2. Open cabinet door.
3. Turn temperature control knob to "LO".
4. Depress and turn gas control knob clockwise to "OFF".

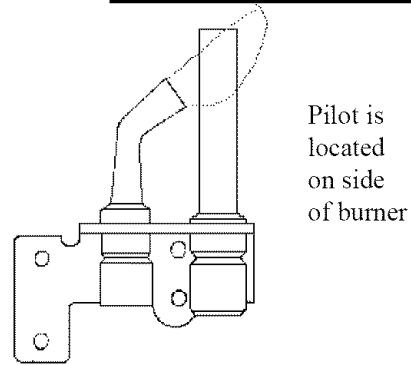
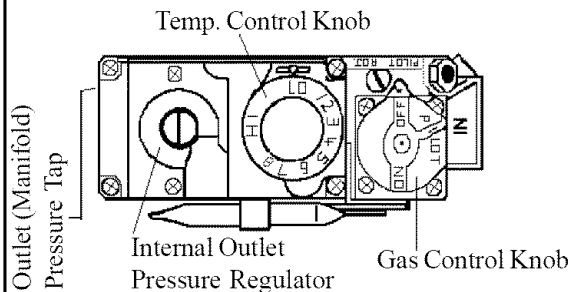

NOTE: Knob can not be turned from "PILOT" to "OFF" unless knob is pushed in slightly. Do not force.

- |  |   |
|--|---|
| <ol style="list-style-type: none"> <li>5. Wait five (5) minutes to clear out any gas. Then smell for gas, including near the floor. If you smell gas, STOP! Follow "B" in the information on the safety label. If you don't smell gas, go to the next step.</li> <li>6. Locate the pilot. (Follow metal pilot tube from gas control).</li> <li>7. Turn gas control knob counterclockwise  to "PILOT".</li> </ol> | <ol style="list-style-type: none"> <li>8. Depress gas control knob and hold in. Immediately light the pilot with a match. Continue to hold the gas control knob in for about one (1) minute after the pilot is lit. Release gas control knob and it will pop back up. Pilot should remain lit. If pilot goes out, repeat steps 4 through 8.</li> <li>• If knob does not pop up when released, STOP and immediately call your service technician or gas supplier.</li> <li>• If the pilot will not stay lit after several tries, turn the gas control knob to "OFF" and call your service technician or gas supplier.</li> <li>9. Turn gas control knob counterclockwise  to "ON".</li> <li>10. Turn temperature control knob to desired setting, usually a setting of 5 or 6 is satisfactory.</li> <li>11. Close the cabinet door.</li> </ol> |
|--|---|

## TO TURN OFF GAS TO APPLIANCE

- |   |  |
|---|--|
| <ol style="list-style-type: none"> <li>1. Open the cabinet door.</li> <li>2. Turn temperature control knob clockwise  to "LO".</li> </ol> | <ol style="list-style-type: none"> <li>3. Push in gas control knob slightly and turn clockwise  to "OFF". Do not force.</li> <li>4. Close cabinet door.</li> </ol> |
|---|--|

## PILOT ADJUSTMENT

Locate the pilot adjustment screw on the valve. The pilot flame should surround at least the top 3/8" of the powerpilot (pilot generator) or thermocouple (see below). The pilot is unregulated so it will be operating at inlet line pressure (Max. 7" w.c. for natural gas and 11" w.c. for propane). To decrease the pilot flame, turn the screw clockwise (approximately seven to nine full turns to bottom of pilot light channel) until you produce sufficient flame at the minimum noise level.

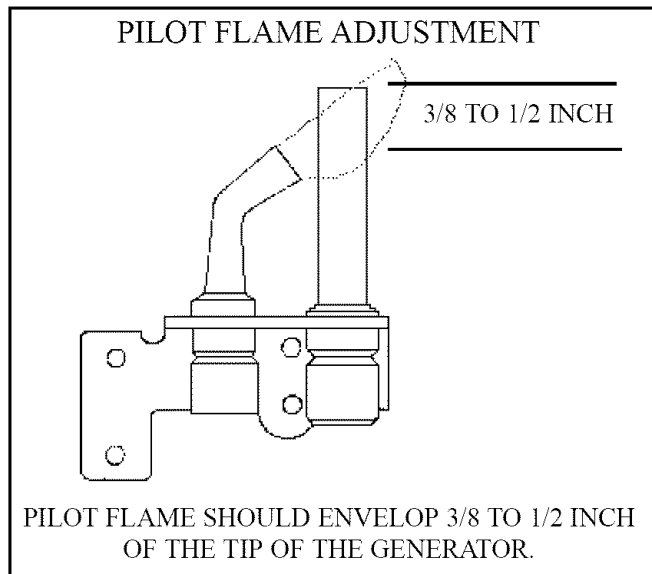

## MAINTENANCE INSTRUCTIONS

1. Installation and repair should be done by a qualified service person. The appliance should be inspected before use and at least annually by a professional service person. More frequent cleaning may be required due to excessive lint from carpeting, bedding material, etc. It is imperative that control compartments, burners, pilot burners, circulating air passageways and venting systems of the appliance be kept clean.
2. If the appliance has been equipped with the optional WFF81-C fan kit assembly, the bearings of the motor should be oiled every six months with approximately 2 drops of S.A.E. 20 oil.
3. The appliance area must be kept clear and free of any combustible materials, gasoline and other flammable vapors and liquids.
4. It is essential that the flow of combustion and ventilation air not be obstructed.
5. Periodic examination of the entire ventilation system as a routine part of the safety performance check is recommended on an annual basis.

## BURNER FLAME ADJUSTMENT - STAINLESS STEEL BURNER

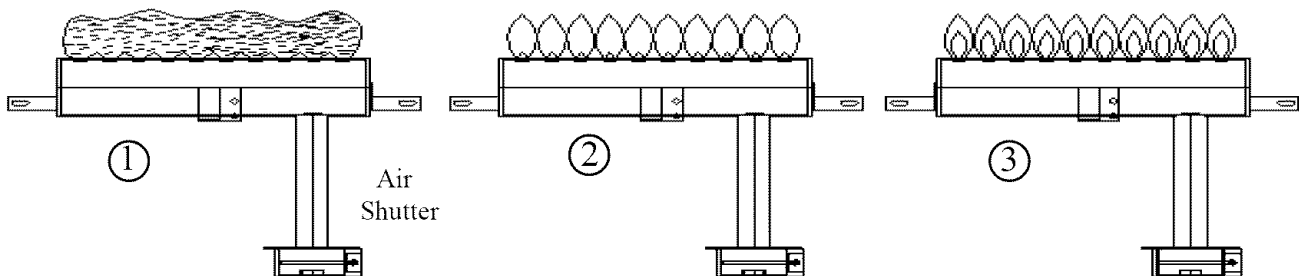

1. **FLAME TOO SOFT** - Yellow Flame. Open air shutters until yellow tipping disappears.

2. **FLAME TOO HARD** - Deep Blue Coloration. Closing air shutters to a point where yellow tipping begins, re-open slightly to eliminate yellow tipping. Air shutter adjustment is now correct.

3. **NORMAL FLAMES**

NOTE: It is advised that the burner flames be checked at least twice during the heating season for any changes in burner characteristics. Vacuum burner compartment at start of heating season or as often as needed.

# MODEL WFF81-C OPTIONAL FAN KIT

## INSTALLATION INSTRUCTIONS

**NOTE:** This fan kit is to be installed after installation of wall furnace and with the wall furnace front panel in place.

- STEP 1.** This appliance, when installed, must be electrically grounded in accordance with local codes, or in the absence of local codes, with the latest edition of the National Electric Code, ANSI/NFPA No. 70. In Canada, see the current Canadian Electrical Code CSA C22.1.
- STEP 2.** Set fan kit on top of the wall furnace front panel. Using the back top edge of the fan kit cabinet as a guide, mark a horizontal line across the wall. Mark a small vertical line which aligns with the slot located toward the rear of the fan kit casing.
- STEP 3.** Using the four one inch screws provided, secure the wall mounting bracket to wall 1/8" below the horizontal line. Fan attachment bracket must be up and threaded nut sert aligned with the small vertical line. Note: Anchors (not provided) may be required.
- STEP 4.** Remove junction box and connect 115v power supply in accordance with the wiring diagram. Replace junction box.
- STEP 5.** Set fan kit on top of wall furnace front panel. Slot should align with the nut sert. Secure fan kit to wall mounting bracket with thumb screw provided.

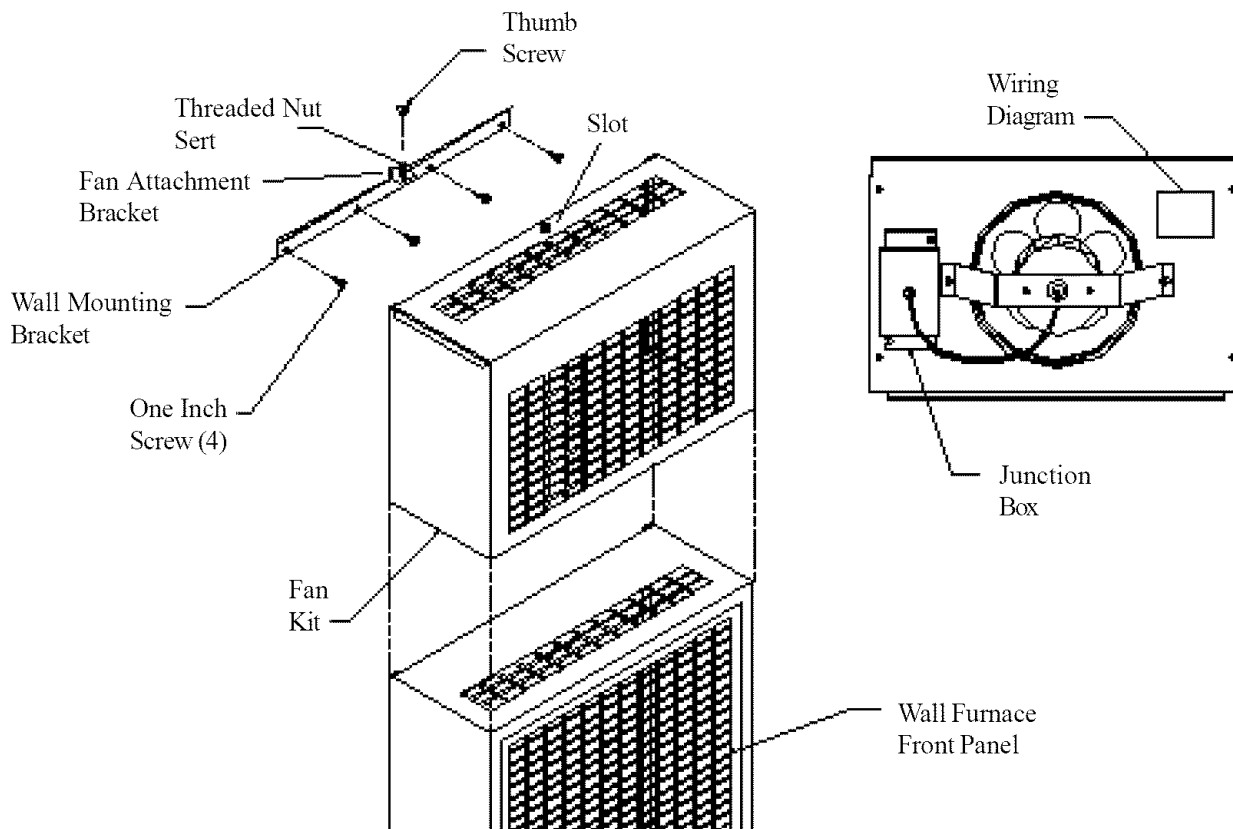

# WFF81-C WIRING SCHEMATIC

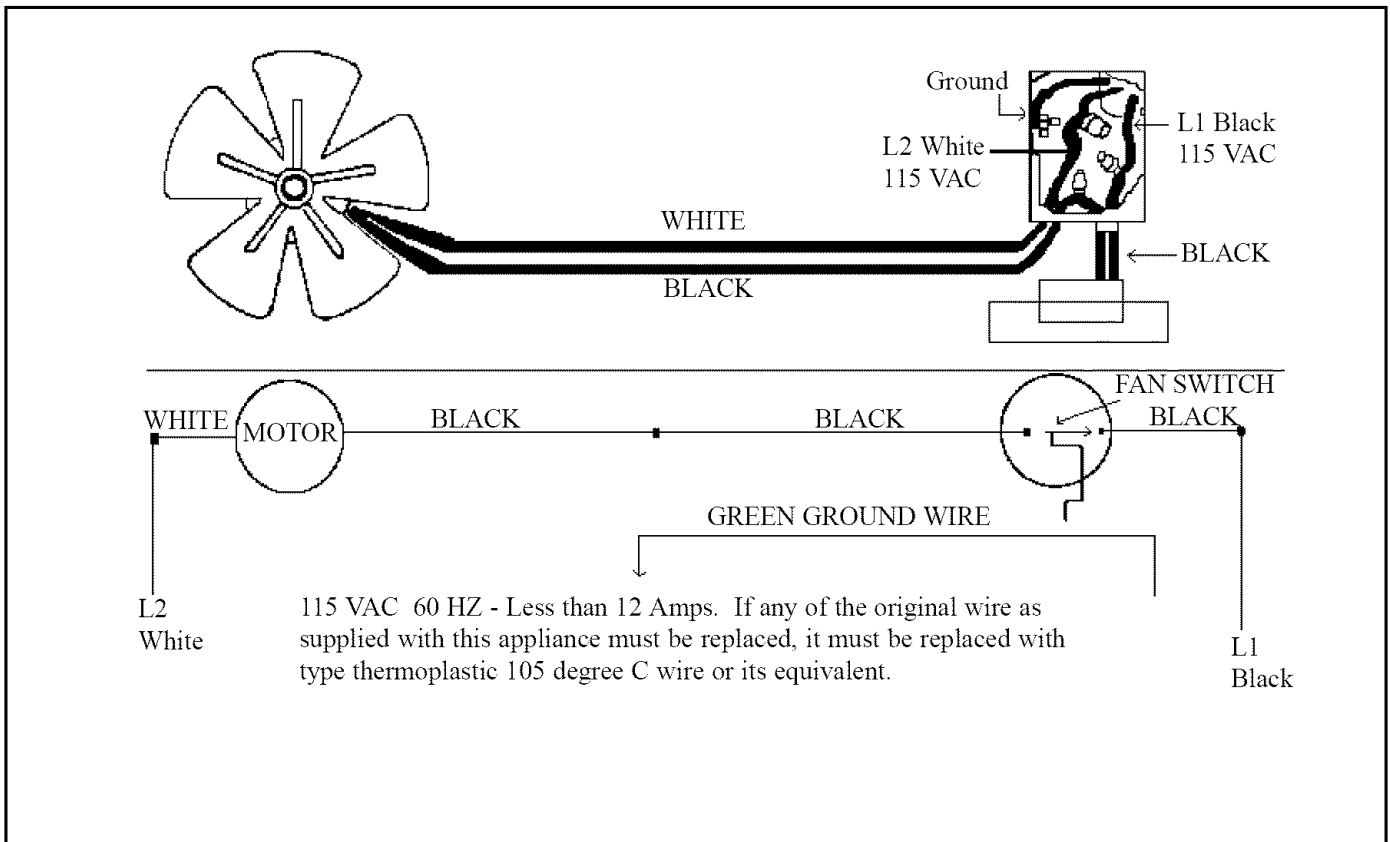

## **TROUBLE SHOOTING CHART for qualified serviceman - MAIN BURNER**

<b>SYMPTOM</b>	<b>POSSIBLE CAUSES</b>	<b>CORRECTIVE ACTION</b>
Flame too large	<ol style="list-style-type: none"> <li>1. Defective operator section of gas valve.</li> <li>2. Burner orifice too large.</li> <li>3. If installed above 2,000 ft.</li> </ol>	<ol style="list-style-type: none"> <li>1. Replace complete valve.</li> <li>2. Check with local gas company for proper orifice size and replace.</li> <li>3. Refer to orifice chart, Page 3.</li> </ol>
Flame pops back	<ol style="list-style-type: none"> <li>1. Too much primary air.</li> </ol>	<ol style="list-style-type: none"> <li>1. Adjust air shutter. (See Page 12).</li> </ol>
Noisy Flame	<ol style="list-style-type: none"> <li>1. Too much primary air.</li> <li>2. Noisy pilot.</li> <li>3. Burr in orifice (if it whistles or resonates).</li> <li>4. Excessive gas input.</li> </ol>	<ol style="list-style-type: none"> <li>1. Adjust air shutter. (See Page 12).</li> <li>2. Reduce pilot gas with adjusting screw on combination gas control valve.</li> <li>3. Remove burr or replace orifice (Do not enlarge orifices).</li> <li>4. See "Flame Too Large" above.</li> </ol>
Yellow tip flame (some yellow tipping on L.P. gas is permissible)	<ol style="list-style-type: none"> <li>1. Too little primary air.</li> <li>2. Clogged main burner ports.</li> <li>3. Clogged draft hood.</li> <li>4. Linted up air shutter.</li> </ol>	<ol style="list-style-type: none"> <li>1. Adjust air shutter. (See Page 12).</li> <li>2. Clean main burner ports. (Do not enlarge ports).</li> <li>3. Clean draft hood.</li> <li>4. Check for dust or lint at air mixer opening and around the shutter. Clean as necessary.</li> </ol>
Floating Flame	<ol style="list-style-type: none"> <li>1. Blocked venting.</li> <li>2. Insufficient primary air.</li> </ol>	<ol style="list-style-type: none"> <li>1. Clean flue passageways to remove blockage.</li> <li>2. Adjust air shutter to increase primary air supply. (See Page 12).</li> </ol>
Gas Odor	<ol style="list-style-type: none"> <li>1. Gas leak.</li> <li>2. Chimney or flue obstruction.</li> <li>3. Drafts around appliance.</li> </ol>	<ol style="list-style-type: none"> <li>1. Shut off gas service immediately. Check piping. Call gas company. (See Page 1).</li> <li>2. Clean flue.</li> <li>3. Eliminate drafts.</li> </ol>
Delayed Ignition	<ol style="list-style-type: none"> <li>1. Pilot flame too small.</li> <li>2. Burner ports clogged near pilot.</li> <li>3. Low gas pressure.</li> <li>4. Pilot decreases in size when main burners come on.</li> <li>5. Air shutter open too far.</li> <li>6. Drafts around appliance.</li> <li>7. Bad venting.</li> </ol>	<ol style="list-style-type: none"> <li>1. Check pilot orifice, increase pilot gas flow if necessary by adjusting inlet pressure.</li> <li>2. Clean burner ports (Do not enlarge ports).</li> <li>3. Check gas supply pressure.</li> <li>4. Supply piping is inadequately sized. Consult local gas utility or competent installer.</li> <li>5. Close air shutter to proper setting as outlined in these instructions (slight yellow tipping is allowable on L.P. Gas). (See Page 12).</li> <li>6. Eliminate drafts.</li> <li>7. See "Venting".</li> </ol>
Failure to Ignite	<ol style="list-style-type: none"> <li>1. Main gas off.</li> <li>2. Defective gas valve.</li> </ol>	<ol style="list-style-type: none"> <li>1. Open all manual gas valves.</li> <li>2. Replace gas valve.</li> </ol>
Condensation of water vapor	<ol style="list-style-type: none"> <li>1. Improper venting.</li> </ol>	<ol style="list-style-type: none"> <li>1. See "Venting".</li> </ol>
Burner won't turn off	<ol style="list-style-type: none"> <li>1. Defective or sticking automatic valve.</li> <li>2. Excessive gas pressure (The supply gas pressure must not exceed 1/2 psi or 14" water column).</li> </ol>	<ol style="list-style-type: none"> <li>1. Clean or replace valve.</li> <li>2. To correct this situation contact the utility supplying the gas.</li> </ol>
Incorrect gas input	<ol style="list-style-type: none"> <li>1. Gas input not checked.</li> <li>2. Clogged orifice.</li> </ol>	<ol style="list-style-type: none"> <li>1. Re-check gas input.</li> <li>2. Check orifice for clogging. If clogged, clean out the hole carefully with a smooth wood toothpick. (Do not in any way enlarge or distort it).</li> </ol>
Not enough heat	<ol style="list-style-type: none"> <li>1. Appliance undersized.</li> <li>2. Temperature dial set too low. (Bulb type valves).</li> <li>3. Incorrect supply pressure.</li> </ol>	<ol style="list-style-type: none"> <li>1. This is especially true when a dwelling or room is enlarged. Have the heat loss calculated and compare to the appliance output (70% of input). Your gas company or installer can supply you with this information. If appliance is undersized, replace with correct size unit.</li> <li>2. Raise setting of Temperature Dial. See "Lighting and Shutting Down Instructions".</li> <li>3. Check supply pressure as outlined above.</li> </ol>
Too much heat	<ol style="list-style-type: none"> <li>1. Temperature dial set too high.</li> <li>2. Combination control valve sticks open.</li> </ol>	<ol style="list-style-type: none"> <li>1. Lower setting of temperature dial. See "Lighting and Shutting Down Instructions".</li> <li>2. Replace combination control valve.</li> </ol>

## TROUBLE SHOOTING CHART - AUTOMATIC PILOT & VALVE

SYMPTOM	POSSIBLE CAUSES	CORRECTIVE ACTION
Burner won't turn on	<ol style="list-style-type: none"> <li>1. Pilot flame too large or too small.</li> <li>2. Dirt in pilot orifice.</li> <li>3. Defective automatic pilot section in combination control valve.</li> <li>4. Defective thermocouple.</li> <li>5. Defective combination control valve.</li> <li>6. Wall thermostat models - manual reset blocked flue switch tripped.</li> </ol>	<ol style="list-style-type: none"> <li>1. Re-adjust pilot flame using adjustment on combination control valve.</li> <li>2. Clean pilot orifice with air or solvent, do not ream.</li> <li>3. Replace entire combination control valve.</li> <li>4. Replace thermocouple.</li> <li>5. Replace valve.</li> <li>6. Reset switch, see Page 6 and blocked flue section below.</li> </ol>

## TROUBLE SHOOTING CHART - BLOCKED FLUE SWITCH (FOR USE BY A QUALIFIED SERVICEMAN)

POSSIBLE CAUSES	CORRECTIVE ACTION
1. Blockage in vent pipe	<ol style="list-style-type: none"> <li>A. Check vent pipe for blockage, such as bird nest, wasp nest, twigs, leaves, etc.</li> <li>B. Check inside the bottom of the vent pipe to make sure the top of the draft diverter did not rip the inner liner causing it to block part of the vent opening.</li> <li>C. Check that no insulation from the header plate got caught on top of the draft diverter when the heater was inserted into the wall.</li> <li>D. Check that the vent cap is properly installed, not shoved too far down on the vent pipe.</li> </ol>
2. Burner is overfiring	<ol style="list-style-type: none"> <li>A. Check the manifold pressure.</li> <li>B. Check the rate, NOTE: This appliance was orificed for elevations up to 2,000 feet. When installed at higher elevations refer to orifice chart in controls section of instructions for proper orifice size and re-orifice accordingly.</li> </ol>
3. Improper vent system A. Vent too short  B. Restriction in vent system caused by offsets  C. Incorrect vent pipe	<ol style="list-style-type: none"> <li>3. Correct vent system.               <ol style="list-style-type: none"> <li>A. The vent should terminate a minimum of 12 feet above the floor. See Figure 2. Also, the top of the vent must be at least 2 foot above any obstacle within a 10 foot radius, including the roof. See Figure A.</li> <li>B. All type "B" vents shall extend in a generally vertical direction with offsets not exceeding 45 degrees, except that a vent system having not more than one 60 degree offset may be allowed. Any angle greater than 45 degrees from the vertical is considered horizontal. The total horizontal run of a vent plus the horizontal vent connector shall be not greater than 75 percent of the vertical height of the vent. Any offsets used should be as far above the drafthood as possible to allow a venting action to begin before any restriction is encountered.</li> <li>C. Use listed BW type vent pipe. Do not use tansite or any other type of ceramic pipe for venting. Do not use single wall pipe. When venting into a masonry chimney the chimney must be properly lined and sized for this gas furnace. The use of type B or flexible chimney liner is recommended.</li> </ol> </li> </ol>
4. Incorrect header plate location	4. The header plate must be 65-3/4" above the floor plate. See rough-in instructions.
5. Vent pipe not down on the header plate securely	5. Use a base plate (obtained from the vent pipe manufacturer) on top of our header plate. This will lock the vent pipe down and prevent the draft diverter from shoving it up.
6. Loose connections on the vent safety wiring harness	6. Check the connection on both the switch and the gas valve. Tighten if necessary.

### **DO NOT BYPASS THE BLOCKED FLUE SWITCH**

**To do so could expose the consumer to property damage, personal injury or possible death.**





Prices and specifications subject to change without notice. All prices are F.O.B. factory.

GRAVITY WALL FURNACE  
LIST PRICES -- JUNE 2004

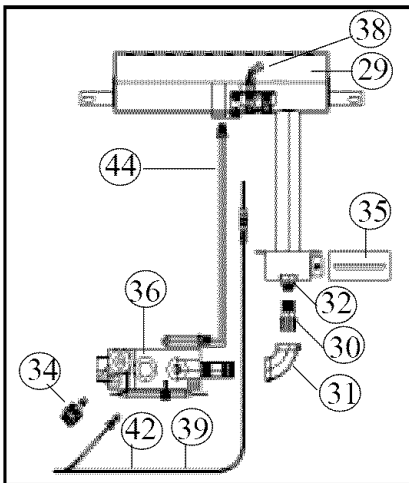
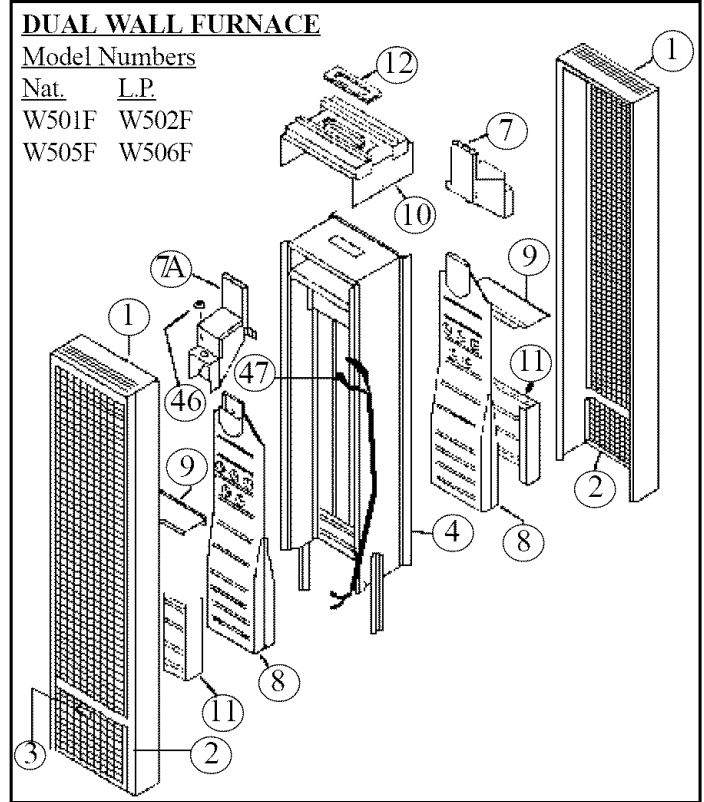
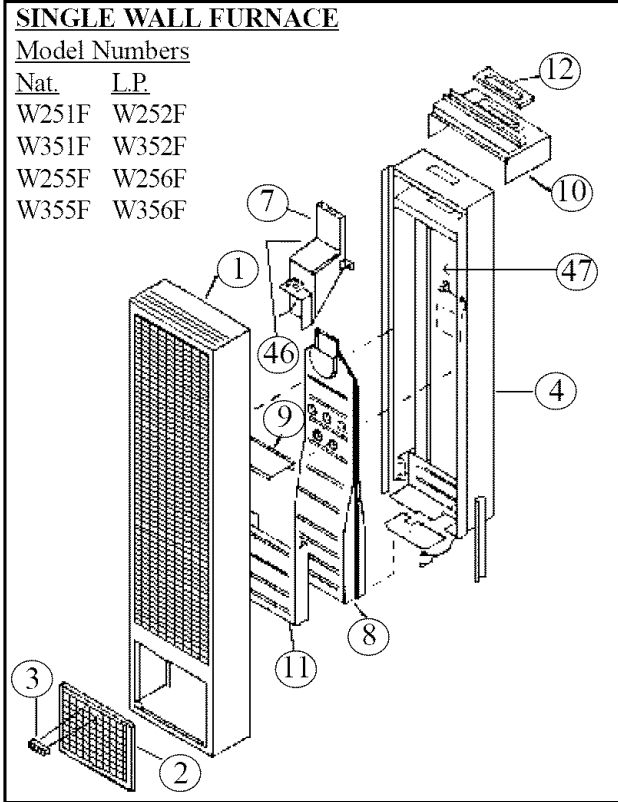

**BURNER ASSEMBLY / SINGLE WALL FURNACE**

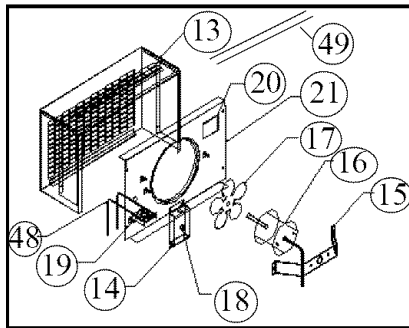

**WFF81-C FAN KIT** Used on Single and Dual Wall models

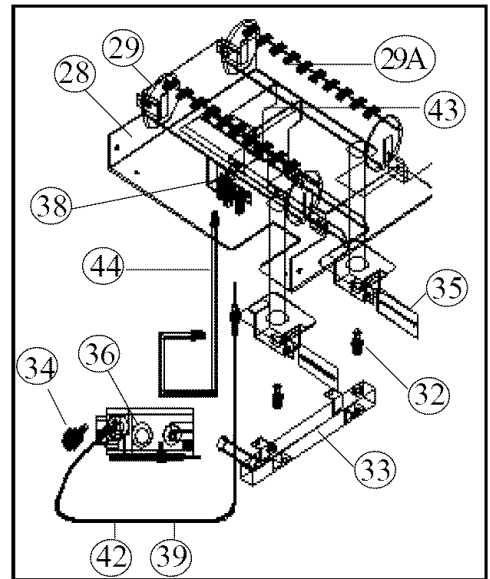

**BURNER ASSEMBLY / DUAL WALL FURNACE**

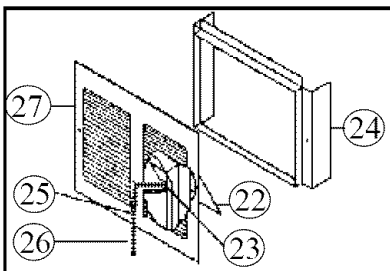

**REAR REGISTER KIT** - Used on Single Wall models only

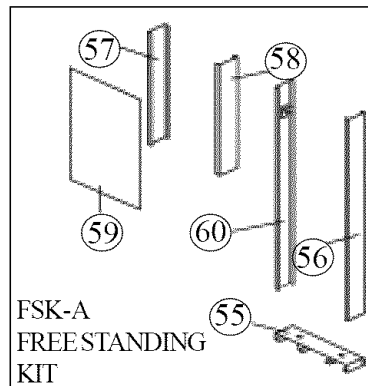

**FSK-A FREE STANDING KIT**

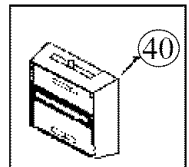

**THERMOSTAT**

NOTICE: When ordering any component in the Burner Assembly, specify either Honeywell or Robertshaw components. REV. 08/02

**HOW TO PROPERLY ORDER PARTS:** In addition to part description and part number, please give model number, serial number, and type of gas used. This information can be found on the rating plate that is attached to heater.

FRONT PANEL, DOOR & BODY ASSEMBLY								WFF81-C FAN KIT (Fits all Models)			
FOR MODELS		W25F		W35F		W50F					
PART DESCRIPTION	REF. NO.	PART NO.	LIST PRICE	PART NO.	LIST PRICE	PART NO.	LIST PRICE	PART DESCRIPTION	REF. NO.	PART NO.	LIST PRICE
Front Panel Assembly	1	40025	\$121.80	40025	\$121.80	*40025	\$121.80	Fan Cabinet	13	40304	\$33.30
Lower Door	2	40032	\$9.60	40032	\$9.60	*40032	\$9.60	Junction Box	14	40315	\$6.80
Handle Assembly	3	40033	\$4.40	40033	\$4.40	*40033	\$4.40	Motor Mounting Brk.	15	40313	\$4.10
Body Assembly	4	39805	\$157.50	39805	\$157.50	40103	\$181.70	Motor	16	85110	\$56.20
Draft Diverter Assembly	7	40042	\$37.20	40045	\$37.10	40141	\$34.20	Fan Blade	17	85115	\$8.10
Draft Diverter Assembly	7A	N/A	N/A	N/A	N/A	40140	\$34.80	Heyco Strain Relief	18	84155	\$1.10
Heat Exchanger	8	40260	\$129.20	40265	\$127.10	*40260	\$129.20	Fan Switch	19	84170	\$5.60
Upper Shield	9	40068	\$2.90	40068	\$2.90	*40068	\$2.90	Wiring Diagram (label)	20	91147	N/C
Header Assembly	10	40055	\$25.90	40055	\$25.90	40150	\$35.00	Fan Housing	21	40311	\$17.90
Lower Front Shield	11	40065	\$13.10	40065	\$13.10	*40065	\$13.10	Fan Switch Wire	48	*84171	\$1.60
Gasket Flue Pipe	12	78050	\$1.10	78050	\$1.10	78050	\$1.10	Wall Mtg. Bracket	49	40317	\$6.10
Blocked Flue Sw. 350 Deg.	46	84166	\$8.90	84166	\$8.90	84166	\$8.90	Installation Manual	N/A	84511	N/C
Wiring Harness/Bulb	47	84134	\$8.90	84134	\$8.90	84134	\$8.90				
Wiring Harness/Wall	47	84133	\$8.90	84133	\$8.90	84133	\$8.90				
E.C.O. Fitting/Bulb	34	84095	\$6.00	84095	\$6.00	84095	\$6.00				
BURNER ASSY. PARTS FOR MODELS:		W251/ 252/ 255 / 256F W351 / 352 / 355 / 356F				W501/ 502F W505/ 506F		40542-A REAR REGISTER (W25/35E & F SERIES ONLY)			
PART DESCRIPTION	REF. NO.	PART NO.	LIST PRICE	PART NO.	LIST PRICE	PART NO.	LIST PRICE	PART DESCRIPTION	REF. NO.	PART NO.	LIST PRICE
Burner, Support Assy.	28	N/A	N/A			40212	\$17.20	Damper	22	40375	\$2.40
Burner, Steel	29	84070	\$39.30			84070	\$39.30	Damper Spring	23	40377	\$1.90
Burner, Steel WITH Carry Over Tapping	29A	N/A	N/A			84071	\$51.40	Frame Assembly	24	40365	\$11.60
Burner Restrictor Plate for W502F and W506F#	N/A	N/A	N/A			#40220	\$2.10	Register Chain	25	40379	\$1.30
Orifice Coupling	30	84631	\$4.50			N/A	N/A	Bell, Pull	26	85003	\$1.10
Elbow 3/8 90 Degree	31	84124	\$2.00			N/A	N/A	Register Assembly	27	40355	\$18.50
Orifices	32				SEE ORIFICES			Installation Manual	N/A	84504	N/C
Manifold	33	N/A	N/A			84072	\$25.80	<b>FSK-A FREE STANDING KIT (W25/W35 only)</b>			
Pipe Nipple	N/A	84123	\$1.70			N/A	N/A	Floor Plate Assembly	55	40405	\$19.00
Pilot Tubing w/Fittings	44	74452	\$6.70			74452	\$6.70	Right Side Assembly	56	40410	\$29.20
Air Shutter	35	84078	\$2.10			*84078	\$2.10	Upper Left Side	57	40415	\$10.80
Valves	36				SEE VALVES			Upper Right Side	58	40416	\$10.80
Pilots	38				SEE PILOTS			Upper Front	59	40418	\$18.30
Pilot Generator	39	70098	\$30.80			70098	\$30.80	Left Side Assembly	60	40422	\$28.20
Thermostat	40	74592	\$19.00			74592	\$19.00				
Wire, Thermostat	41	74518	\$1.20			74518	\$1.20				
Thermocouple	42	70096	\$11.30			70096	\$11.30				
Carry Over Shield	43	N/A	N/A			40209	\$9.00				
Installation Instructions	N/A	84502	N/C			84502	N/C				
Lighting Instr., Bulb	N/A	91263	N/C			91263	N/C				
Lighting Instr., Wall	N/A	91253	N/C			91253	N/C				
VALVES (Ref. No. 36)						PILOTS (Ref. No.38)		ORIFICES (Ref. No. 32)			
PART DESCRIPTION ROBERTSHAW	PART NO.	Part Desc. DEXEN	PART NO.	LIST PRICE	MODEL NUMBER	PART NO.	LIST PRICE	PARTS DESCRIPTION	PART NO.	LIST PRICE	
7000SRLC Nat.	70092	6003H Nat.	84087	\$134.40	W251F	84128	\$9.30	Q350A1545 NAT.	84639	\$3.20	
7000SRLC L.P.	70093	6003H L.P.	84088	\$143.90	W252F	84127	\$9.30	Q350A1867 L.P.	84634	\$3.20	
7000MVRLC Nat.	70090	6003 Nat.	84085	\$129.20	W255F	84128	\$9.30	Q350A1545 NAT.	84639	\$3.20	
7000MVRLC-L.P.	70091	6003 L.P.	84086	\$137.60	W256F	84127	\$9.30	Q358A1867 L.P.	84634	\$3.20	
7000SRLC Nat.	70092	6003H Nat.	84087	\$134.40	W351F	84128	\$9.30	Q350A1545 NAT.	84642	\$3.20	
7000SRLC L.P.	70093	6003H L.P.	84088	\$143.90	W352F	84127	\$9.30	Q350A1867 L.P.	84644	\$3.20	
7000MVRLC Nat.	70090	6003 Nat.	84085	\$129.20	W355F	84128	\$9.30	Q350A1545 NAT.	84642	\$3.20	
7000MVRLC-L.P.	70091	6003 L.P.	84086	\$137.60	W356F	84127	\$9.30	Q350A1867 L.P.	84644	\$3.20	
7000SRLC Nat.	70092	6003H Nat.	84087	\$134.40	W501F	84128	\$9.30	Q350A1545 NAT.	*95274	\$3.20	
7000SRLC L.P.	70093	6003H L.P.	84088	\$143.90	W502F	84127	\$9.30	Q350A1867 L.P.	*84648	\$3.20	
7000MVRLC Nat.	70090	6003 Nat.	84085	\$129.20	W505F	84128	\$9.30	Q350A1545 NAT.	*95274	\$3.20	
7000MVRLC-L.P.	70091	6003 L.P.	84086	\$137.60	W506F	84127	\$9.30	Q350A1867 L.P.	*84648	\$3.20	

**Mr. Contractor,** we only sell parts through our wholesalers, but the prices listed are for your convenience. For prompt parts service, contact the wholesaler from which you purchased your Cozy heater. **NOTE:** Parts & schematic drawings on current models are shown at [www.cozyheaters.com](http://www.cozyheaters.com).

# IMPORTANT SAFETY BULLETIN ON YOUR GAS CONTROL AND PILOT LIGHT SYSTEM FOR HEATING EQUIPMENT

## WHAT YOU DON'T KNOW CAN HURT YOU.

Your pilot light system has been designed for safe and reliable operation. Although safety mechanisms are built-in, the potential for hazard exists. This information is intended to help you avoid these hazards.

### YOUR GAS CONTROL AND PILOT LIGHT SYSTEM

Your gas control and pilot light system has a safety device whose purpose is to shut-off the gas supply to the appliance if the pilot light goes out. If you have trouble lighting the pilot or keeping it lit, it may mean that this safety device is warning you that there is a problem with your system. Inspection and repairs or replacement must be made by a trained gas service technician.



### TAMPERING IS DANGEROUS

The pilot safety system may also not work if you do not follow the lighting instructions carefully or if you tamper with the gas control that you use to light the pilot. Tampering with the gas control, particularly with tools, can damage the safety mechanism in the control and can allow gas to leak. This can result in a fire or explosion causing property damage, personal injury or death.

### IF YOU SMELL GAS, DON'T LIGHT IT

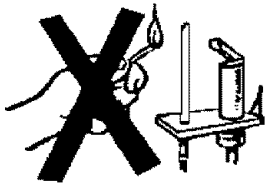

IF YOU CAN'T LIGHT IT,  
DON'T FIGHT IT!



THIS IS NOT AN ADVERTISEMENT

### WHAT TO DO IF YOU SMELL GAS . . .

- Do not try to light any appliance.
- Do not touch any electrical switch; do not use any phone in your building.
- Immediately call your gas supplier from a neighbor's phone. Follow the gas supplier's instructions.
- If you cannot reach your gas supplier, call the fire department.

Installation and service must be performed by a qualified installer, service agency or the gas supplier.

Do not store or use gasoline or other flammable vapors and liquids in the vicinity of this or any other appliance.

### CRITICAL SAFETY POINTS TO REMEMBER . . .

- Your gas has been odorized so that you can smell it. Always smell around for gas before lighting your appliance.
- Sniff for L.P.-gas at floor level. LP-gas is heavier than air and may temporarily exist at floor level.



- If you smell gas, do not attempt to light the pilot. Do not cause a spark by turning on or off electrical switches or appliances or by using the phone. Turn off the gas to the appliances and call your gas supplier from another location.
- If your gas control has gotten wet as the result of flooding or other wetting, it must be replaced immediately by a trained gas service technician. Water can lead to damage of the internal safety mechanism in the gas control and can create a hazardous condition.

# LIMITED WARRANTY

The Louisville Tin & Stove Co. warrants to the original user the accompanying product for the period specified herein, provided said product is installed, operated, maintained, serviced, and used according to the instructions and specifications accompanying the product. **AS OUTLINED IN OUR INSTRUCTIONS, ANY WARRANTY CONSIDERATIONS ARE CONTINGENT ON INSTALLATION BY A QUALIFIED INSTALLER (CONTRACTOR). SELF-INSTALLATION IS NOT RECOMMENDED AND MY INVALIDATE YOUR WARRANTY.**

If within a period of one year from the date of installation of the product, any part supplied by the manufacturer proves to be defective due to workmanship or material, it will replace such part, provided parts have not been subjected to misuse, alteration, neglect, or accidents. The term of the warranty for the heat exchanger is covered in Table A below. Any claim not made within ten (10) days after the expiration of the warranty period shall be deemed waived by the user.

The manufacturer shall have no liability or be required to perform any obligation under this warranty unless, when requested, the user returns, at the user's expense, the component or product claimed defective, to the manufacturer for inspection, to enable the manufacturer to determine if the claimed defect is covered by this warranty.

No charges for freight, labor or other expenses incurred in the repair, removal, or replacement of any product or component claimed to be defective, will be paid by the manufacturer to the user, and the manufacturer will not be liable for any expenses incurred, by the user, in remedying any defect in the product.

Service under this warranty is the responsibility of the installer. In the event service under this warranty is needed, the user of the product shall request such service

directly from the installer. If the user is unable to locate the installer, the user should write directly to the manufacturer, and the name of an alternative service source will be supplied.

The product safety registration card (packed inside the appliance) must be completed and returned to the factory.

THIS WARRANTY IS EXPRESSLY IN LIEU OF ANY OTHER WARRANTIES, EXPRESS OR IMPLIED (WHETHER WRITTEN OR ORAL). ANY IMPLIED WARRANTY OF MERCHANTABILITY OR OF FITNESS FOR A PARTICULAR PURPOSE IS EXPRESSLY LIMITED TO THE DURATION OF THE MANUFACTURER'S EXPRESS, WRITTEN WARRANTY.

UNDER NO CIRCUMSTANCES SHALL THE MANUFACTURER BE LIABLE FOR ANY SPECIAL, INDIRECT OR CONSEQUENTIAL DAMAGES OR EXPENSES ARISING DIRECTLY OR INDIRECTLY FROM ANY COMPONENT OR FROM THE USE THEREOF. THE REMEDIES SET FORTH HEREIN SHALL BE THE EXCLUSIVE REMEDIES AVAILABLE TO THE USER AND ARE IN LIEU OF ALL OTHER REMEDIES.

SOME STATES DO NOT ALLOW LIMITATIONS ON HOW LONG AN IMPLIED WARRANTY LASTS, SO THE ABOVE LIMITATIONS MAY NOT APPLY TO YOU.

SOME STATES DO NOT ALLOW THE EXCLUSION OR LIMITATION OF INCIDENTAL OR CONSEQUENTIAL DAMAGES, SO THE ABOVE LIMITATIONS OR EXCLUSIONS MAY NOT APPLY TO YOU.

THIS WARRANTY GIVES YOU SPECIFIC LEGAL RIGHTS, AND YOU MAY ALSO HAVE OTHER RIGHTS, WHICH VARY, FROM STATE TO STATE.

**TABLE A**  
**Warranty for gas appliance heat exchangers only.**

<u>Product</u>	<u>Warranty Period</u>
Cozy Gas Fired Floor Furnace	10 Years
Cozy Gas Fired Wall Furnace	10 Years
Cozy Gas Fired Vented Console Heater	10 Years
Cozy Gas Fired Direct Vent Heater	10 Years
Cozy Gas Fired Counterflow Furnace	10 Years
Cozy Gas Fired Counterflow Direct Vent Furnace	10 Years
Cozy Gas Fired Mobile Home Direct Vent Furnace	10 Years
Cozy Gas Fired Hi-Efficient Direct Vent Wall Furnace	10 Years

LOUISVILLE TIN AND STOVE COMPANY

P.O. BOX 2767 - LOUISVILLE, KY. 40201-2767