

Owner's Manual

**CRAFTSMAN®**  
**5.5 HORSEPOWER**  
**21" MULTI-CUT**  
**ROTARY LAWN MOWER**

Model No.  
**917.388330**

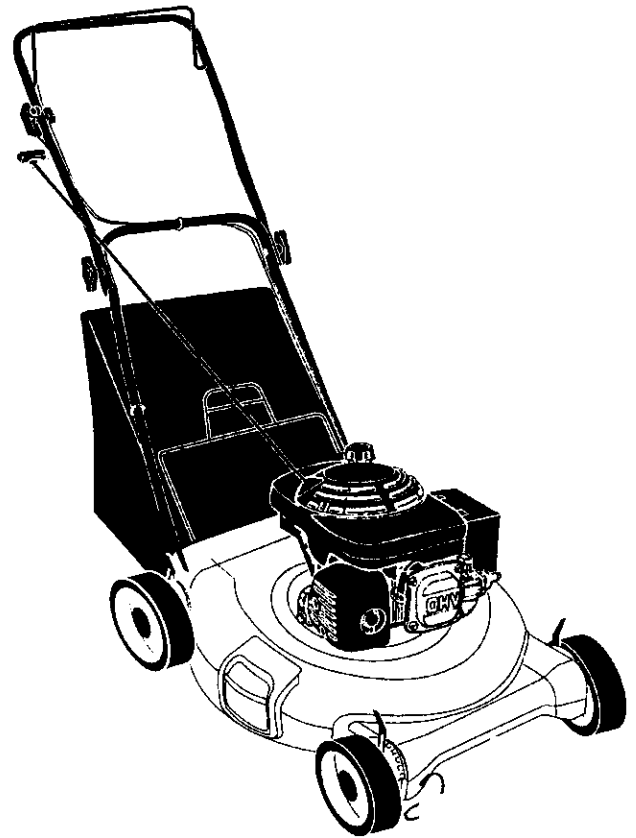

- **Safety**
- **Assembly**
- **Operation**
- **Maintenance**
- **Español**
- **Repair Parts**

**CAUTION:**

Read and follow all  
Safety Rules and Instructions  
before operating this equipment

Sears, Roebuck and Co., Hoffman Estates, IL 60179  
Visit our Craftsman website: [www.sears.com/craftsman](http://www.sears.com/craftsman)

## TABLE OF CONTENTS

Warranty .....	2	Product Specifications .....	11
Safety Rules .....	2	Service and Adjustments .....	13
Assembly .....	4	Storage .....	14
Operation .....	6	Troubleshooting .....	15
Maintenance Schedule .....	10	Repair Parts .....	34
Maintenance .....	10	Parts Ordering .....	Back Cover

## WARRANTY

### LIMITED TWO YEAR WARRANTY ON CRAFTSMAN POWER MOWER

For two years from date of purchase, when this Craftsman Lawn Mower is maintained, lubricated, and tuned up according to the operating and maintenance instructions in the owner's manual, Sears will repair free of charge any defect in material or workmanship.

If this Craftsman Lawn Mower is used for commercial or rental purposes, this warranty applies for only 90 days from the date of purchase.

This Warranty does not cover:

- Expendable items which become worn during normal use, such as rotary mower blades, blade adapters, belts, air cleaners and spark plug.
- Repairs necessary because of operator abuse or negligence, including bent crankshafts and the failure to maintain the equipment according to the instructions contained in the owner's manual.

Warranty service is available by returning the Craftsman power mower to the nearest Sears Service Center/Department in the United States. This warranty applies only while this product is in use in the United States.

This Warranty gives you specific legal rights, and you may also have other rights which vary from state to state.

SEARS, ROEBUCK AND CO., D/817 WA, HOFFMAN ESTATES, ILLINOIS 60179

## SAFETY RULES

Safety standards require operator presence control to minimize the risk of injury. Your unit is equipped with such controls. Do not attempt to defeat the function of the operator presence controls under any circumstances.

### TRAINING:

- Read this operator's manual carefully. Become familiar with the controls and know how to operate your mower properly. Learn how to quickly stop mower.
- Do not allow children to use your mower. Never allow adults to use mower without proper instructions.
- Keep the area of operation clear of all persons, especially small children and pets.
- Use mower only as the manufacturer intended and as described in this manual.

- Do not operate mower if it has been dropped or damaged in any manner. Always have damage repaired before using your mower.
- Do not use accessory attachments that are not recommended by the manufacturer. Use of such attachments may be hazardous.
- The blade turns when the engine is running.

### PREPARATION:

- Always thoroughly check the area to be mowed and clear it of all stones, sticks, wires, bones, and other foreign objects. These objects will be thrown by the blade and can cause severe injury.
- Always wear safety glasses or eye shields when starting and while using your mower.
- Dress properly. Do not operate mower when barefoot or wearing open

- sandals. Wear only solid shoes with good traction when mowing.
- Check fuel tank before starting engine. Do not fill gas tank indoors, when the engine is running or when the engine is hot. Allow the engine to cool for several minutes before filling the gas tank. Clean off any spilled gasoline before starting the engine.
- Always make wheel height adjustments before starting your mower. Never attempt to do this while the engine is running.
- Mow only in daylight or good artificial light.

#### **OPERATION:**

- Keep your eyes and mind on your mower and the area being cut. Do not let other interests distract you.
- Do not mow wet or slippery grass. Never run while operating your mower. Always be sure of your footing - keep a firm hold on the handles and walk.
- Do not put hands or feet near or under rotating parts. Keep clear of the discharge opening at all times.
- Always stop the engine whenever you leave or are not using your mower, or before crossing driveways, walks, roads, and any gravel-covered areas.
- Never direct discharge of material toward bystanders nor allow anyone near the mower while you are operating it.
- Before cleaning, inspecting, or repairing your mower, stop the engine and make absolutely sure the blade and all moving parts have stopped. Then disconnect the spark plug wire and keep it away from the spark plug to prevent accidental starting.
- Do not continue to run your mower if you hit a foreign object. Follow the procedure outlined above, then repair any damage before restarting and operating your mower.
- Do not change the governor settings or overspeed the engine. Engine damage or personal injury may result.
- Do not operate your mower if it vibrates abnormally. Excessive vibration is an indication of damage; stop the engine, safely check for the cause of vibration and repair as required.
- Do not run the engine indoors. Exhaust fumes are dangerous.

- Never cut grass by pulling the mower towards you. Mow across the face of slopes, never up and down or you might lose your footing. Do not mow excessively steep slopes. Use caution when operating the mower on uneven terrain or when changing directions - maintain good footing.
- Never operate your mower without proper guards, plates, grass catcher or other safety devices in place.

#### **MAINTENANCE AND STORAGE:**

- Check the blade and the engine mounting bolts often to be sure they are tightened properly.
- Check all bolts, nuts and screws at frequent intervals for proper tightness to be sure mower is in safe working condition.
- Keep all safety devices in place and working.
- To reduce fire hazard, keep the engine free of grass, leaves or excessive grease and oil.
- Check grass catcher often for deterioration and wear and replace worn bags. Use only replacement bags that are recommended by and comply with specifications of the manufacturer of your mower.
- Always keep a sharp blade on your mower.
- Allow engine to cool before storing in any enclosure.
- Never store mower with fuel in the tank inside a building where fumes may reach an open flame or an ignition source such as a hot water heater, space heater, clothes dryer, etc.

**⚠** Look for this symbol to point out important safety precautions. It means **CAUTION!!! BECOME ALERT!!! YOUR SAFETY IS INVOLVED.**



**⚠CAUTION:** Always disconnect spark plug wire and place wire where it cannot contact spark plug in order to prevent accidental starting when setting up, transporting, adjusting or making repairs.

**⚠WARNING:** The engine exhaust from this product contains chemicals known to the State of California to cause cancer, birth defects, or other reproductive harm.



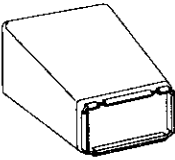
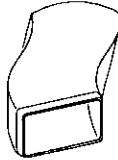
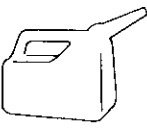

## ACCESSORIES

These accessories were available when this lawn mower was produced. **They are not shipped with your mower.** They are also available at most Sears retail outlets and service centers. Most Sears stores can also order repair parts for you, when you provide the model number of your lawn mower. Some of these accessories may not apply to your lawn mower.

### LAWN MOWER PERFORMANCE

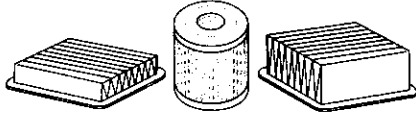
 <p><b>CLIPPING DEFLECTOR</b> FOR REAR DISCHARGE LAWN MOWERS</p>	 <p><b>MULCHER KITS</b></p>	 <p><b>STABILIZER</b></p>
 <p><b>GRASS CATCHERS</b> FOR REAR DISCHARGE LAWN MOWERS</p>	 <p><b>GRASS CATCHERS</b> FOR SIDE DISCHARGE LAWN MOWERS</p>	 <p><b>GAS CANS</b></p>

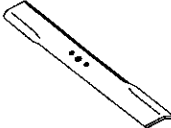
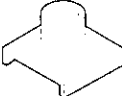
### LAWN MOWER MAINTENANCE

 <p><b>MUFFLERS</b></p>		 <p><b>AIR FILTERS</b></p>		 <p><b>SPARK PLUGS</b></p>
 <p><b>BELTS</b></p>	 <p><b>BLADES</b></p>	 <p><b>BLADE ADAPTERS</b></p>	 <p><b>WHEELS</b></p>	 <p><b>ENGINE OIL</b></p>

## ASSEMBLY

Read these instructions and this manual in its entirety before you attempt to assemble or operate your new lawn mower.

**IMPORTANT:** This lawn mower is shipped **WITHOUT OIL OR GASOLINE** in the engine.

Your new lawn mower has been assembled at the factory with the exception of those parts left unassembled for shipping purposes. To ensure safe and proper operation of your lawn mower, all parts and hardware you assemble must be tightened securely. Use the correct tools as necessary to ensure proper tightness. All parts such as nuts, washers, bolts, etc., necessary to complete the assembly have been placed in the parts bag.

### TO REMOVE LAWN MOWER FROM CARTON

- Remove loose parts included with mower.
- Cut down two end corners of carton and lay end panel down flat.
- Remove all packing materials except padding between upper and lower handle and padding holding operator presence control bar to upper handle.
- Roll lawn mower out of carton and check carton thoroughly for additional loose parts.

## HOW TO SET UP YOUR LAWN MOWER

### TO UNFOLD HANDLE

**IMPORTANT:** Unfold handle carefully so as not to pinch or damage control cables.

- Raise handles until lower handle section locks into place in mowing position.
- Remove protective padding, raise upper handle section into place on lower handle and tighten both handle knobs.
- Remove handle padding holding operator presence control bar to upper handle.
- Your lawn mower handle can be adjusted for your mowing comfort. Refer to "Adjust Handle" in the Service and Adjustments section of this manual.

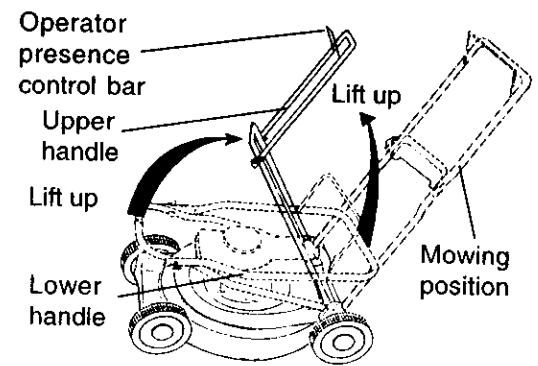

### TO INSTALL ATTACHMENTS

Your lawn mower was shipped ready to be used as a mulcher. To convert to bagging or discharging, see "To convert mower" in the OPERATION section of this manual.

# OPERATION

## KNOW YOUR LAWN MOWER

READ THIS OWNER'S MANUAL AND SAFETY RULES BEFORE OPERATING YOUR LAWN MOWER. Compare the illustrations with your lawn mower to familiarize yourself with the location of various controls and adjustments. Save this manual for future reference.

**These symbols may appear on your lawn mower or in literature supplied with the product. Learn and understand their meaning.**

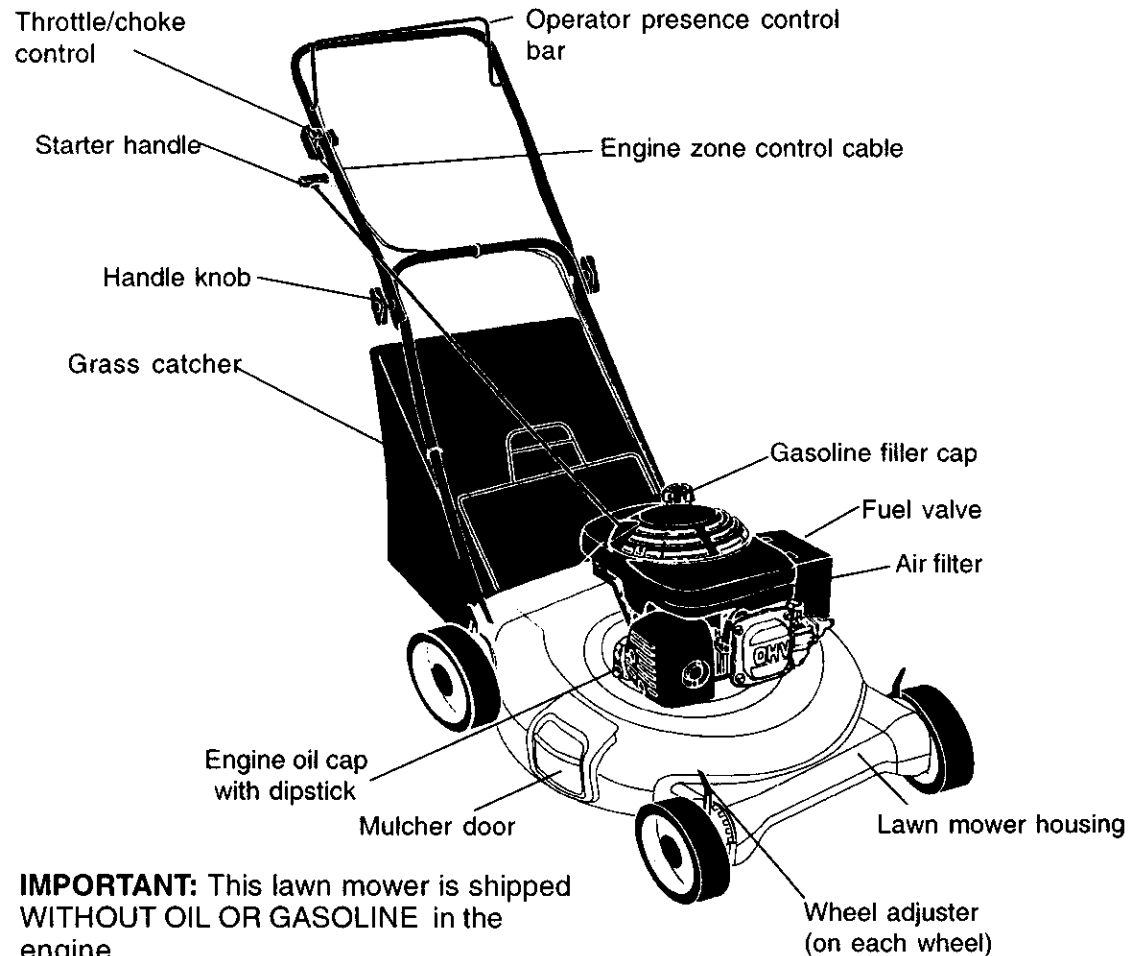
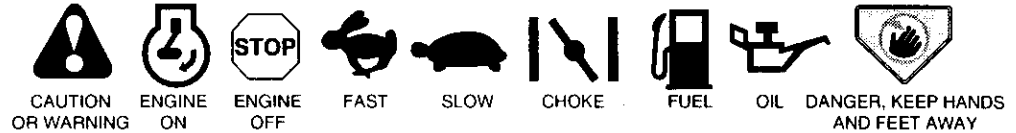

**IMPORTANT:** This lawn mower is shipped WITHOUT OIL OR GASOLINE in the engine.

### MEETS CPSC SAFETY REQUIREMENTS

Sears rotary walk-behind power lawn mowers conform to the safety standards of the American National Standards Institute and the U.S. Consumer Product Safety Commission. The blade turns when the engine is running.

**Operator Presence Control Bar-** must be held down to the handle to start the engine. Release to stop the engine.

**Primer -** pumps additional fuel from the carburetor to the cylinder for use when starting a cold engine.

**Starter Handle -** used for starting the engine.



The operation of any lawn mower can result in foreign objects thrown into the eyes, which can result in severe eye damage. Always wear safety glasses or eye shields while operating your lawn mower or performing any adjustments or repairs. We recommend a wide vision safety mask over spectacles or standard safety glasses.

## HOW TO USE YOUR LAWN MOWER ENGINE SPEED

The engine speed is controlled by a throttle control located on the side of the upper handle. Choke position is for starting a cold engine and fast position is for normal cutting, trimming, and better grass bagging. Slow position is for light cutting, trimming and fuel economy.

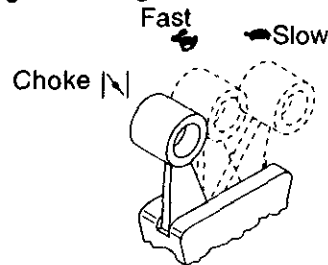

## ENGINE ZONE CONTROL

**CAUTION:** Federal regulations require an engine control to be installed on this lawn mower in order to minimize the risk of blade contact injury. Do not under any circumstances attempt to defeat the function of the operator control. The blade turns when the engine is running.

- Your lawn mower is equipped with an operator presence control bar which requires the operator to be positioned behind the lawn mower handle to start and operate the lawn mower.

## TO ADJUST CUTTING HEIGHT

- Raise wheels for low cut and lower wheels for high cut.
- Adjust cutting height to suit your requirements. Medium position is best for most lawns.
- To change cutting height, squeeze adjuster lever toward wheel. Move wheel up or down to suit your requirements. Be sure all wheels are in the same setting.

**NOTE:** Adjuster is properly positioned when plate tab inserts into hole in lever. Also, 9-position adjusters (if so equipped) allow lever to be positioned between the plate tabs.

## Lower Wheels for High Cut

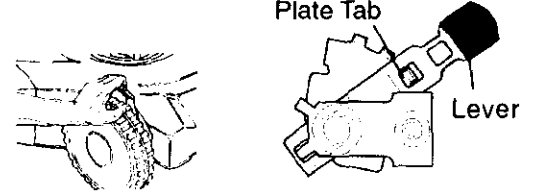

## Raise Wheels for Low Cut TO CONVERT MOWER

Your lawn mower was shipped ready to be used as a mulcher. To convert to bagging or discharging:

### REAR BAGGING

- Lift rear door of the lawn mower and place the grass catcher frame hooks onto the door pivot pins.
- To convert to mulching or discharging operation, remove grass catcher and close rear door.

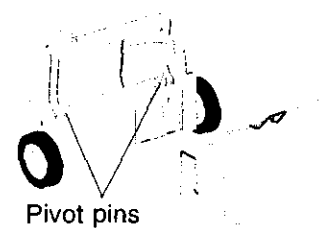

### SIDE DISCHARGING

- Rear door must be closed.
- Open mulcher door and install discharge deflector under guard as shown.
- Mower is now ready for discharging operation.
- To convert to mulching or bagging operation, discharge deflector must be removed and mulcher door must be closed.

### SIMPLE STEPS TO REMEMBER WHEN CONVERTING YOUR LAWN MOWER

#### FOR MULCHING -

- Rear door closed.
- Mulcher door closed.

#### FOR REAR BAGGING -

- Grass catcher installed.
- Mulcher door closed.

#### FOR SIDE DISCHARGING -

- Rear door closed.
- Side discharge deflector installed.

**CAUTION:** Do not run your lawn mower without rear door closed or approved grass catcher in place. Never attempt to operate the lawn mower with the rear door removed or propped open.

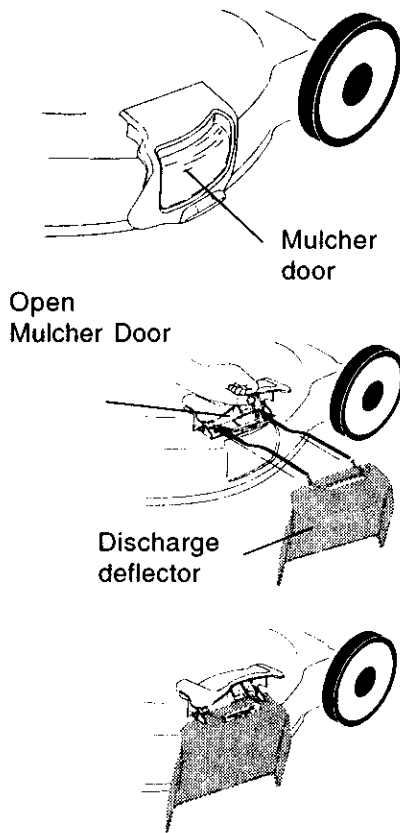

## BEFORE STARTING ENGINE OIL

Your lawn mower is shipped without oil in the engine.

- Be sure mower is level and area around oil fill is clean.
- Remove engine oil cap and fill to the upper limit mark on dipstick.

**NOTE:** Allow oil to settle down into engine for accurate dipstick reading.

- Engine holds 18 1/2 ozs. of oil. For type and grade of oil to use, see "ENGINE" in Maintenance section of this manual.
- Pour oil slowly. Do not over fill.
- Check oil level before each use. Add oil if needed. Fill to the upper limit mark on dipstick.
- To read proper level, insert the dipstick into the tube and rest engine oil cap on the tube. Do not thread the cap onto the tube. Remove and read the oil level.
- Reinstall engine oil cap and tighten.
- Change the oil after every 25 hours of operation or each season. You may need to change the oil more often under dusty, dirty conditions.

## ADD GASOLINE

- Fill fuel tank. Use fresh, clean, regular unleaded gasoline with a minimum of 87 octane. Do not mix oil with gasoline. Purchase fuel in quantities that can be used within 30 days to assure fuel freshness.

**⚠ WARNING:** Experience indicates that alcohol blended fuels (called gasohol or using ethanol or methanol) can attract moisture which leads to separation and formation of acids during storage. Acidic gas can damage the fuel system of an engine while in storage. To avoid engine problems, the fuel system should be emptied before storage of 30 days or longer. Drain the fuel tank, start the engine and let it run until fuel lines and carburetor are empty. Use fresh fuel next season. See Storage Instructions for additional information. Never use engine or carburetor cleaner products in fuel tank or permanent damage may occur.

**⚠ CAUTION:** Fill to bottom of gas tank filler neck. Do not overfill. Wipe off any spilled oil or fuel. Do not store, spill or use gasoline near an open flame.

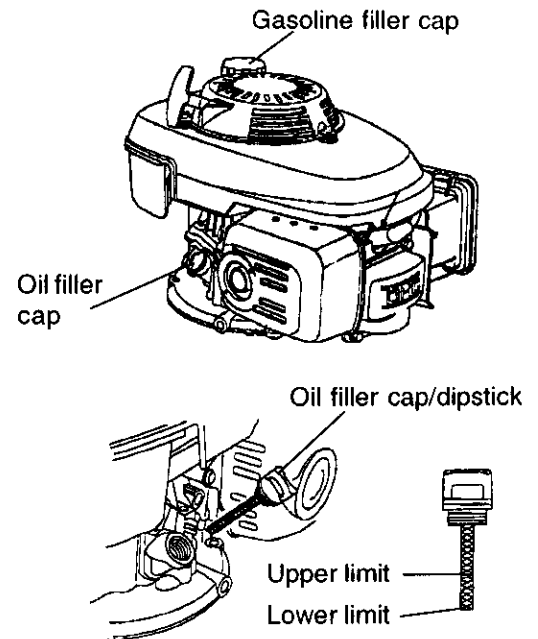



## TO START ENGINE

- Turn fuel valve to ON position.
- To start a cold engine, move handle mounted throttle/choke control lever to choke position.
- Hold operator presence control bar down to the handle and pull starter handle quickly. Do not allow starter rope to snap back.
- Slowly move throttle control lever to fast position after engine starts.
- To start a warm engine, move throttle control lever to fast or slow position then follow steps above.
- To stop engine, release operator presence control bar. Wait until blade and all moving parts have stopped and turn fuel valve to OFF position if you do not intend to restart the engine soon.

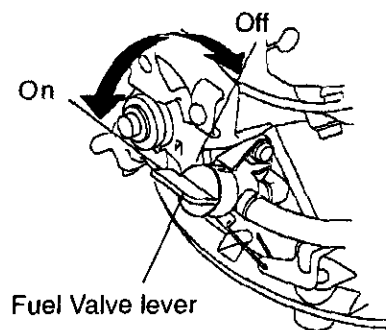

Fuel Valve lever

## MOWING TIPS

- Under certain conditions, such as very tall grass, it may be necessary to raise the height of cut to reduce pushing effort and to keep from overloading the engine and leaving clumps of grass clippings. It may also be necessary to reduce ground speed and/or run the lawn mower over the area a second time.
- For extremely heavy cutting, reduce the width of cut by overlapping previously cut path and mow slowly.
- For better grass bagging and most cutting conditions, the engine speed should be set in the fast position.
- Pores in cloth grass catchers can become filled with dirt and dust with use and catchers will collect less grass. To prevent this, regularly hose catcher off with water and let dry before using.
- Keep top of engine around starter clear and clean of grass clippings and chaff. This will help engine air flow and extend engine life.

## MULCHING MOWING TIPS

**IMPORTANT:** For best performance, keep mower housing free of built-up grass and trash. Clean **UNDERSIDE OF MOWER HOUSING** after each use. See "Cleaning" in **MAINTENANCE** section of this manual.

- The special mulching blade will recut the grass clippings many times and reduce them in size so that as they fall onto the lawn they will disperse into the grass and not be noticed. Also, the mulched grass will biodegrade quickly to provide nutrients for the lawn. Always mulch with your highest engine (blade) speed as this will provide the best recutting action of the blades.
- Avoid cutting your lawn when it is wet. Wet grass tends to form clumps and interferes with the mulching action. The best time to mow your lawn is the early afternoon. At this time the grass has dried and the newly cut area will not be exposed to the direct sun.
- For best results, adjust the lawn mower cutting height so that the lawn mower cuts off only the top one-third of the grass blades. If the lawn is overgrown it will be necessary to raise the height of cut to reduce pushing effort and to keep from overloading the engine and leaving clumps of mulched grass. For extremely heavy mulching, reduce your width of cut, mow slowly and raise the rear of the lawn mower one wheel adjuster setting higher than the front.
- Certain types of grass and grass conditions may require that an area be mulched a second time to completely hide the clippings. When doing a second cut, mow across or perpendicular to the first cut path.
- Change your cutting pattern from week to week. Mow north to south one week then change to east to west the next week. This will help prevent matting and graining of the lawn.

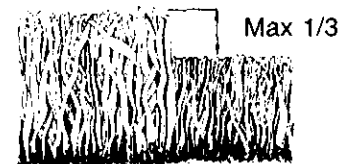



# PRODUCT SPECIFICATIONS

MODEL NUMBER	917.388330
SERIAL NUMBER	
DATE OF PURCHASE	
GASOLINE CAPACITY/TYPE:	1.0 QUARTS UNLEADED REGULAR
OIL TYPE (API-SF/SG/SH):	SAE 30 (ABOVE 32°F) SAE 5W-30 (BELOW 32°F)
OIL CAPACITY:	18.5 OZS.
SPARK PLUG(GAP: .030")	(NGK) BPR6ES
VALVE CLEARANCE:	INTAKE: .004 - .007 EXHAUST: .006 - .009
BLADE BOLT TORQUE:	35-40 FT. LBS.
<ul style="list-style-type: none"> <li>The model and serial numbers will be found on a decal attached to the rear of the lawn mower housing. Record both serial number and date of purchase in space provided above.</li> </ul>	

## LAWN MOWER

Always observe safety rules when performing any maintenance.

### TIRES

- Keep tires free of gasoline, oil, or insect control chemicals which can harm rubber.
- Avoid stumps, stones, deep ruts, sharp objects and other hazards that may cause tire damage.

### BLADE CARE

For best results, mower blade must be kept sharp. Replace bent or damaged blades.

### TO REMOVE BLADE

- Disconnect spark plug wire from spark plug and place wire where it cannot come in contact with spark plug.
- Turn lawn mower on its side. Make sure air filter and carburetor are up.
- Use a wood block between blade and mower housing to prevent blade from turning when removing blade bolt.
- Protect your hands with gloves and/or wrap blade with heavy cloth.
- Remove blade bolt by turning counter-clockwise. Use a 9/16" box or open-end wrench.
- Remove blade and attaching hardware.

### TO REPLACE BLADE

- Position the blade adapter on the engine crankshaft. Be sure the spacer is in the adaptor and key in shaft and adaptor keyway are aligned.
- Position blade on the blade adapter. Be sure the trailing edge of blade (opposite sharp edge) is up toward the engine.
- Install the blade bolt with washers into blade adapter and crankshaft.
- Use block of wood between blade and lawn mower housing and tighten the blade bolt, turning clockwise.
- The recommended tightening torque is 35-40 ft. lbs.

**IMPORTANT:** Blade bolt is grade 8 heat treated.

## TO SHARPEN BLADE

**NOTE:** We do not recommend sharpening blade - but if you do, be sure the blade is balanced.

Care should be taken to keep the blade balanced. An unbalanced blade will cause eventual damage to lawn mower or engine.

- The blade can be sharpened with a file or on a grinding wheel. Do not attempt to sharpen while on the mower.
- To check blade balance, drive a nail into a beam or wall. Leave about one inch of the straight nail exposed. Place center hole of blade over the head of the nail. If blade is balanced, it should remain in a horizontal position. If either end of the blade moves downward, sharpen the heavy end until the blade is balanced.

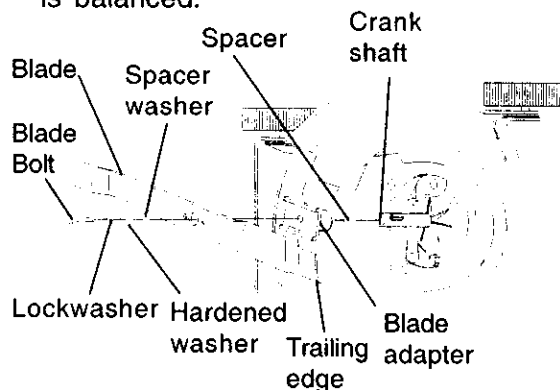

## GRASS CATCHER

- The grass catcher may be hosed with water, but must be dry when used.
- Check your grass catcher often for damage or deterioration. Through normal use it will wear. If catcher needs replacing, replace only with a manufacturer approved replacement catcher. Give the lawn mower model number when ordering.

## ENGINE LUBRICATION

Use only high quality detergent oil rated with API service classification SF, SH or SG. Select the oil's SAE viscosity grade according to your expected operating temperature.

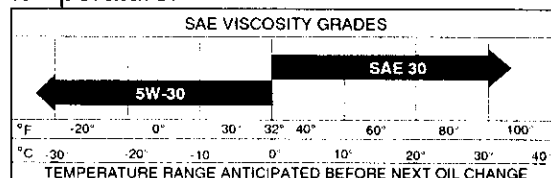

**NOTE:** Although multi—viscosity oils (5W30, 10W30 etc.) improve starting in cold weather, these multi—viscosity oils will result in increased oil consumption when used above 32°F. Check your engine oil level more frequently to avoid possible engine damage from running low on oil.

Change the oil after every 25 hours of operation or at least once a year if the lawn mower is not used for 25 hours in one year.

Check the crankcase oil level before starting the engine and after each five (5) hours of continuous use. Tighten oil plug securely each time you check the oil level.

## TO CHANGE ENGINE OIL

**NOTE:** Before tipping lawn mower to drain oil, drain fuel tank by running engine until fuel tank is empty.

- Disconnect spark plug wire from spark plug and place wire where it cannot come in contact with spark plug.
- Remove engine oil cap; lay aside on a clean surface.
- Tip lawn mower on its side as shown and drain oil into a suitable container. Rock lawn mower back and forth to remove any oil trapped inside of engine.
- Wipe off any spilled oil on lawn mower and on side of engine.
- Fill engine with oil. Fill to the upper limit mark on the dipstick. **DO NOT OVER FILL.**
- To read proper level, insert the dipstick into the tube and rest oil fill cap on the tube. Do not thread the cap onto the tube. Remove and read the oil level.
- Replace engine oil cap.
- Reconnect spark plug wire to spark plug.

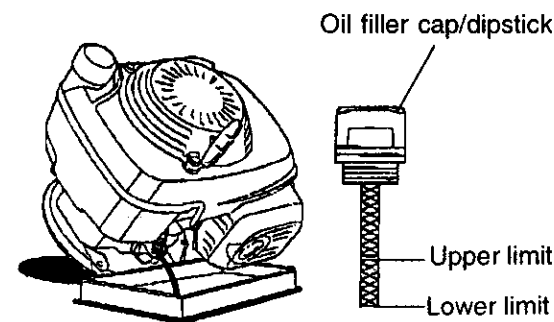

## AIR FILTER

Your engine will not run properly and may be damaged by using a dirty air filter. Replace the air filter every year, more often if you mow in very dusty, dirty conditions.

### TO CLEAN AIR FILTER

- Remove cover.
- Carefully remove cartridge.
- Clean by gently tapping on a flat surface. If very dirty, replace cartridge.

**CAUTION:** Petroleum solvents, such as kerosene, are not to be used to clean cartridge. They may cause deterioration of the cartridge. Do not oil cartridge. Do not use pressurized air to clean or dry cartridge.

- Install cartridge, then replace cover.

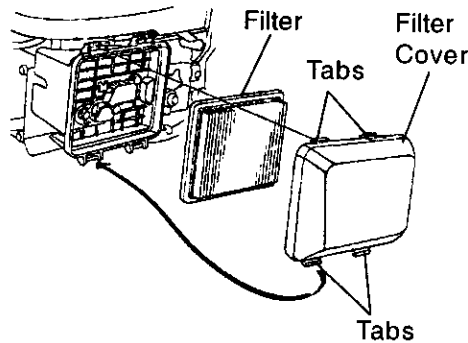

## MUFFLER

Inspect and replace corroded muffler as it could create a fire hazard and/or damage.

## SPARK PLUG

Change your spark plug each year to make your engine start easier and run better. Set spark plug gap at .030 inch.

## CLEANING

**IMPORTANT:** For best performance, keep mower housing free of built-up grass and trash. Clean underside of mower housing after each use.

**CAUTION:** Disconnect spark plug wire from spark plug and place wire where it cannot come in contact with the spark plug.

- Turn lawn mower on its side. Make sure air filter and carburetor are up. Clean the underside of your lawn mower by scraping to remove build-up of grass and trash.
- Clean engine often to keep trash from accumulating. A clogged engine runs hotter and shortens engine life.
- Keep finished surfaces and wheels free of all gasoline, oil, etc.
- We DO NOT recommend using a garden hose to clean lawn mower unless the electrical system, muffler, air filter and carburetor are covered to keep water out. Water in engine can result in shortened engine life.

## SERVICE AND ADJUSTMENTS

**CAUTION:** Before performing any service or adjustments:

- Release control bar and stop engine.
- Make sure the blade and all moving parts have completely stopped.
- Disconnect spark plug wire from spark plug and place where it cannot come in contact with plug.

## LAWN MOWER

### TO ADJUST CUTTING HEIGHT

See "TO ADJUST CUTTING HEIGHT" in the Operation section of this manual.

### REAR DEFLECTOR

The rear deflector, attached between the rear wheels of your lawn mower, is provided to minimize the possibility that objects will be thrown out the rear of the lawn mower into the operator's mowing position.

If the rear deflector becomes damaged, it should be replaced.

### TO ADJUST HANDLE

The handle can be mounted in a high or low position. The mounting holes in the bottom of lower handle are off center for raising or lowering the handle.

- Remove upper handle and all parts attached to lower handle.
- Remove hairpin cotter from lower handle bracket mounting pin.
- Squeeze lower handle in to remove it from mounting pins.
- Turn lower handle over to raise or lower handle.
- Squeeze lower handle in and position holes onto mounting pins on handle bracket.
- Reassemble upper handle and all parts removed from lower handle.



### TO ASSEMBLE GRASS CATCHER

- Put grass catcher frame into grass bag with rigid part of bag on the bottom. Make sure the frame handle is outside of the bag top.

- Slip vinyl bindings over frame.

**NOTE:** If vinyl bindings are too stiff, hold them in warm water for a few minutes. If bag gets wet, let it dry before using.

**CAUTION:** Do not run your lawn mower without clipping deflector or approved grass catcher in place. Never attempt to operate the lawn mower with the rear door removed or propped open.

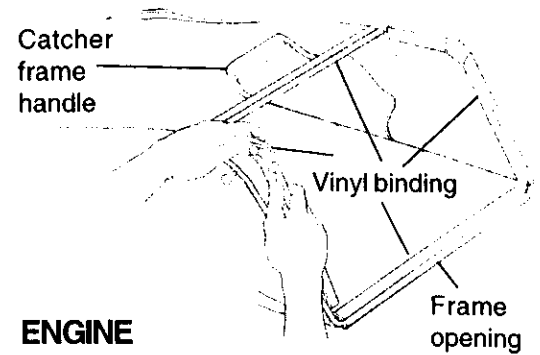

### ENGINE CARBURETOR

If your engine does not operate properly due to suspected carburetor problems, take your lawn mower to an authorized service center for repair or adjustment.

**IMPORTANT:** Never tamper with the engine governor, which is factory set for proper engine speed. Overspeeding the engine above the factory high speed setting can be dangerous. If you think the engine-governed high speed needs adjusting, contact your nearest authorized service center, which has proper equipment and experience to make any necessary adjustments.

### ENGINE SPEED

Your engine speed has been factory set. Do not attempt to increase engine speed or it may result in personal injury. If you believe that the engine is running too fast or too slow, take your lawn mower to an authorized service center for repair and adjustment.

## STORAGE

Immediately prepare your lawn mower for storage at the end of the season or if the unit will not be used for 30 days or more.

### LAWN MOWER

When lawn mower is to be stored for a period of time, clean it thoroughly, remove all dirt, grease, leaves, etc. Store in a clean, dry area.

- Clean entire lawn mower (See "CLEANING" in the Maintenance section of this manual).
- Lubricate as shown in the Maintenance section of this manual.
- Be sure that all nuts, bolts, screws, and pins are securely fastened. Inspect moving parts for damage, breakage and wear. Replace if necessary.
- Touch up all rusted or chipped paint surfaces; sand lightly before painting.

### HANDLE

You can fold your lawn mower handle for storage.

- Squeeze the bottom ends of the lower handle toward each other until the lower handle clears the handle bracket, then move handle forward.

- Loosen upper handle mounting bolts enough to allow upper handle to be folded back.

**IMPORTANT:** When folding the handle for storage or transportation, be sure to fold the handle as shown or you may damage the control cables.

- When setting up your handle from the storage position, the lower handle will automatically lock into the mowing position.

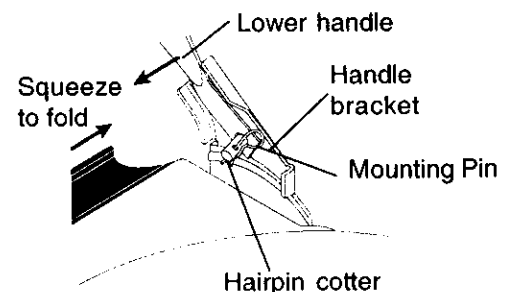

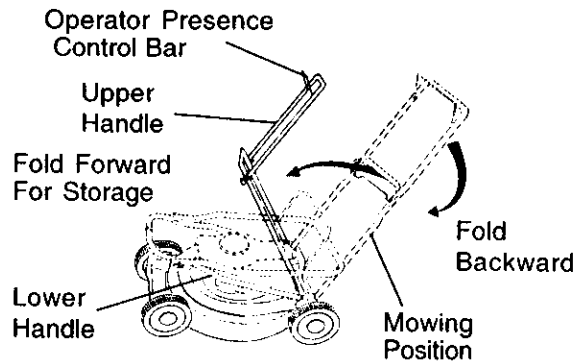

**ENGINE  
FUEL SYSTEM**

**IMPORTANT:** It is important to prevent gum deposits from forming in essential fuel system parts such as carburetor, fuel filter, fuel hose, or tank during storage.

Also, experience indicates that alcohol blended fuels (called gasohol or using ethanol or methanol) can attract moisture which leads to separation and formation of acids during storage. Acidic gas can damage the fuel system of an engine while in storage.

- Drain the fuel tank.
- Start the engine and let it run until the fuel lines and carburetor are empty.
- Never use engine or carburetor cleaner products in the fuel tank or permanent damage may occur.
- Use fresh fuel next season.

**NOTE:** Fuel stabilizer is an acceptable alternative in minimizing the formation of fuel gum deposits during storage. Add stabilizer to gasoline in fuel tank or storage container. Always follow the mix

ratio found on stabilizer container. Run engine at least 10 minutes after adding stabilizer to allow the stabilizer to reach the carburetor. Do not drain the gas tank and carburetor if using fuel stabilizer.

**ENGINE OIL**

Drain oil (with engine warm) and replace with clean engine oil. (See "ENGINE" in the Maintenance section of this manual).

**CYLINDER**

- Remove spark plug.
- Pour one ounce (29 ml) of oil through spark plug hole into cylinder.
- Pull starter handle slowly a few times to distribute oil.
- Replace with new spark plug.

**OTHER**

- Do not store gasoline from one season to another.
- Replace your gasoline can if your can starts to rust. Rust and/or dirt in your gasoline will cause problems.
- If possible, store your unit indoors and cover it to give protection from dust and dirt.
- Cover your unit with a suitable protective cover that does not retain moisture. Do not use plastic. Plastic cannot breathe which allows condensation to form and will cause your unit to rust.

**IMPORTANT:** Never cover mower while engine and exhaust areas are still warm.

**CAUTION:** Never store the lawn mower with gasoline in the tank inside a building where fumes may reach an open flame or spark. Allow the engine to cool before storing in any enclosure.

**TROUBLESHOOTING CHART**

PROBLEM	CAUSE	CORRECTION
<b>Does not start</b>	1. Dirty air filter.	1. Clean/replace air filter.
	2. Out of fuel.	2. Fill fuel tank.
	3. Stale fuel.	3. Drain tank and refill with fresh clean fuel.
	4. Water in fuel.	4. Drain fuel tank and carburetor and refill tank with fresh gasoline.
	5. Spark plug wire is disconnected.	5. Connect wire to plug.
	6. Bad spark plug.	6. Replace spark plug.
	7. Loose blade or broken blade adapter.	7. Tighten blade bolt or replace blade adapter.
	8. Control bar in released position.	8. Depress control bar to handle.
	9. Control bar defective.	9. Replace control bar.

## TROUBLESHOOTING CHART

PROBLEM	CAUSE	CORRECTION
<b>Loss of power</b>	<ol style="list-style-type: none"> <li>1. Rear of lawn mower housing or cutting blade dragging in heavy grass.</li> <li>2. Cutting too much grass.</li> <li>3. Dirty air filter.</li> <li>4. Buildup of grass, leaves, and trash under mower.</li> <li>5. Too much oil in engine.</li> <li>6. Walking speed too fast.</li> </ol>	<ol style="list-style-type: none"> <li>1. Set to "Higher Cut" position.</li> <li>2. Set to "Higher Cut" position.</li> <li>3. Clean/replace air filter.</li> <li>4. Clean underside of mower housing.</li> <li>5. Check oil level.</li> <li>6. Cut at slower walking speed.</li> </ol>
<b>Poor cut – uneven</b>	<ol style="list-style-type: none"> <li>1. Worn, bent or loose blade.</li> <li>2. Wheel heights uneven.</li> <li>3. Low engine speed</li> <li>4. Buildup of grass, leaves and trash under mower.</li> </ol>	<ol style="list-style-type: none"> <li>1. Replace blade. Tighten blade bolt.</li> <li>2. Set all wheels at same height</li> <li>3. Contact an authorized center/ department</li> <li>4. Clean underside of mower housing.</li> </ol>
<b>Excessive vibration</b>	<ol style="list-style-type: none"> <li>1. Worn, bent or loose blade.</li> <li>2. Bent engine crankshaft.</li> </ol>	<ol style="list-style-type: none"> <li>1. Replace blade. Tighten blade bolt.</li> <li>2. Contact an authorized service center.</li> </ol>
<b>Starter rope hard to pull</b>	<ol style="list-style-type: none"> <li>1. Engine flywheel brake is on when control bar is released.</li> <li>2. Bent engine crankshaft.</li> <li>3. Blade adapter broken.</li> <li>4. Blade dragging in grass.</li> </ol>	<ol style="list-style-type: none"> <li>1. Depress control bar to upper handle before pulling starter rope.</li> <li>2. Contact an authorized service center.</li> <li>3. Replace blade adapter.</li> <li>4. Move lawn mower to cut grass or to hard surface</li> </ol>
<b>Grass catcher not filling (if so equipped)</b>	<ol style="list-style-type: none"> <li>1. Cutting height too low.</li> <li>2. Lift on blade worn off.</li> <li>3. Catcher not venting air.</li> <li>4. Low engine speed</li> </ol>	<ol style="list-style-type: none"> <li>1. Raise cutting height.</li> <li>2. Replace blade.</li> <li>3. Clean grass catcher.</li> <li>4. Contact an authorized center/ department</li> </ol>
<b>Hard to push</b>	<ol style="list-style-type: none"> <li>1. Grass is too high or wheel height is too low.</li> <li>2. Rear of lawn mower housing or blade dragging in grass.</li> <li>3. Grass catcher too full.</li> <li>4. Handle height position not right for you.</li> </ol>	<ol style="list-style-type: none"> <li>1. Raise cutting height.</li> <li>2. Raise rear of lawn mower housing one (1) setting higher.</li> <li>3. Empty grass catcher.</li> <li>4. Adjust handle height to suit.</li> </ol>





# CRAFTSMAN ROTARY LAWN MOWER -- MODEL NO. 917.388330

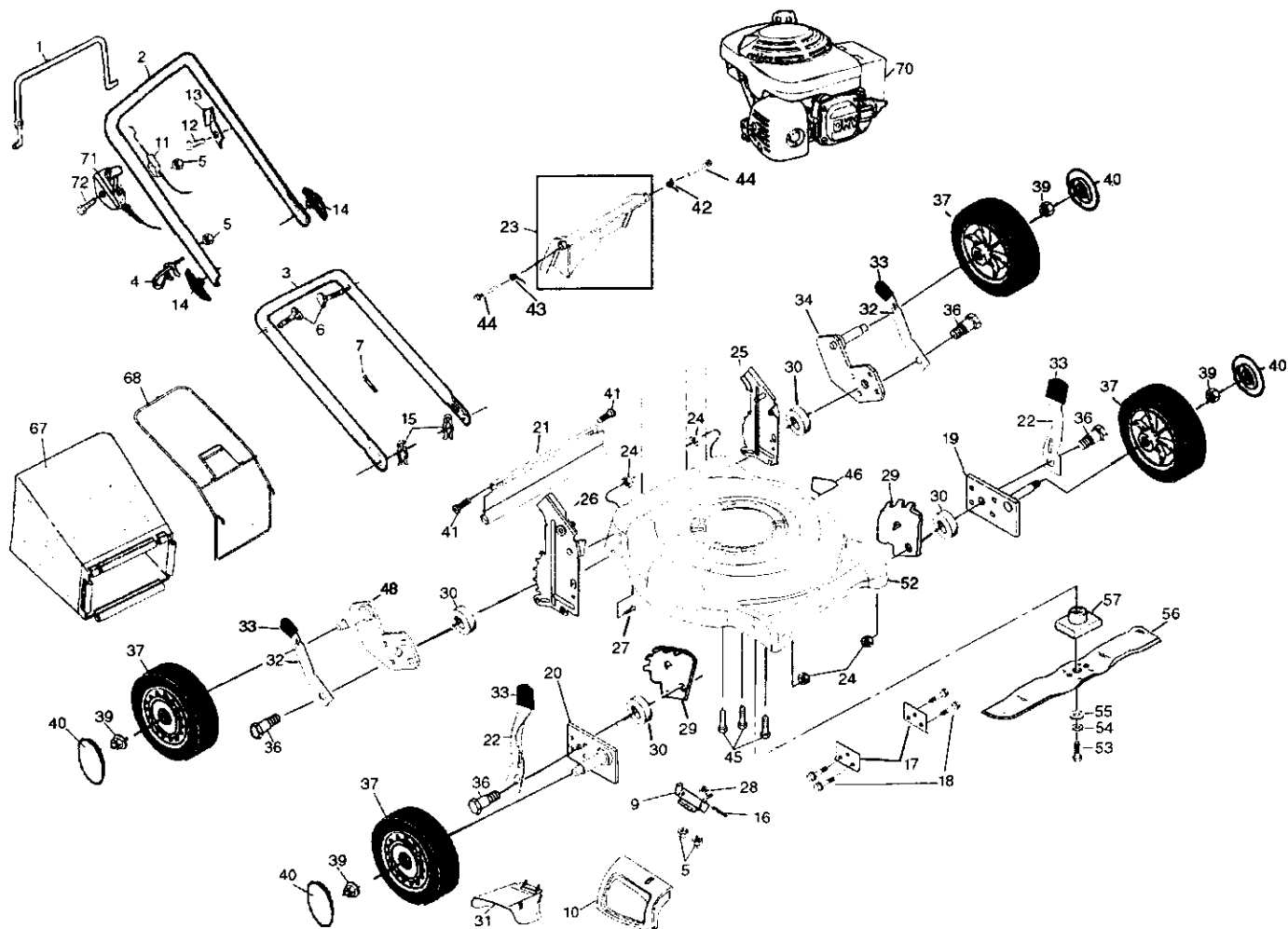

### CRAFTSMAN ROTARY LAWN MOWER -- MODEL NO. 917.388330

KEY NO.	PART NO.	DESCRIPTION	KEY NO.	PART NO.	DESCRIPTION
1	86902	Control Bar	34	165762X004	Axle Arm Assembly - LR
2	169709X479	Upper Handle	36	160828	Shoulder Bolt 5/16-18
3	169708X479	Lower Handle	37	151157	Wheel Assembly
4	132001	Rope Guide	39	83923	Flanged Locknut
5	63601	Locknut 1/4-20	40	77400	Hubcap
6	131959	Handle Bolt	41	88652	Hinge Screw
7	66426	Wire Tie	42	165766	Spring (LH)
9	154132	Hinge Bracket	43	165767	Spring (RH)
10	165754	Mulcher Door	44	165912	Door Bolt
11	851671	Engine Zone Control Cable	45	150406	Hex Head Thread Rolling Screw 3/8-16 x 1
12	750097	Hex Washer Head Screw #10-24 x 1/2	46	85463	Danger Decal
13	850733X004	Up-Stop Bracket	48	165761X004	Axle Arm Assembly - RR
14	136376	Handle Knob	52	166878	Housing Assembly (Incl. Ref. #17, 18 & 46)
15	51793	Hairpin Cotter	53	851084	Hex Head Screw 3/8-24 x 1-3/8 Grd. 8
16	147286	Hinge Rod	54	850263	Helical Lockwasher
17	165946X479	Support Bracket	55	851074	Hardened Washer
18	17600406	Screw	56	165833	21" Blade
19	167132X004	Axle Arm Assembly - LF	57	851514	Blade Adapter
20	167133X004	Axle Arm Assembly - RF	67	166113	Grass Bag
21	165858	Rear Skirt	68	165755	Catcher Frame
22	168360X004	Selector Spring - Front	70	-----	Engine - (See Breakdown) Honda GCV160
23	166875	Rear Door Assembly Kit (Incl. Springs)			
24	751153	Locknut 5/16-18	71	147758	Throttle Control
25	166111X479	Handle Bracket Assembly (Left)	72	144929	Screw
26	166112X479	Handle Bracket Assembly (Right)	--	161058	Warning Decal (Not Shown)
27	851856	Screw 1/4-20 x 3/8	--	172490	Owner's Manual
28	152124	Hinge Spring			
29	160835X007	Wheel Adjusting Bracket - Front			
30	19112222	Spacer			
31	165760	Clip on Discharge Guard			
32	169421X004	Selector Spring - Rear			
33	87877	Selector Knob			

Available accessories not included with lawn mower:

- 71 33623 Gas Can (2.5 gal.)
- 71 33500 Fuel Stabilizer
- 71 33000 SAE 30W Oil (20 oz.)

CONTROL

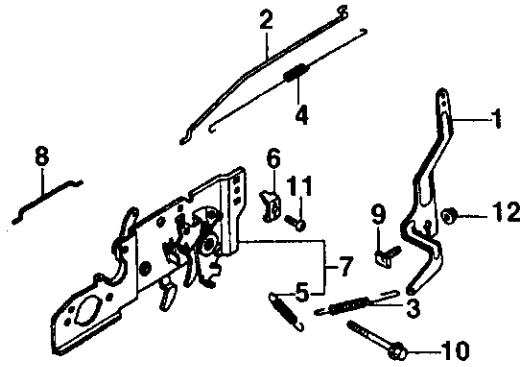

CAMSHAFT

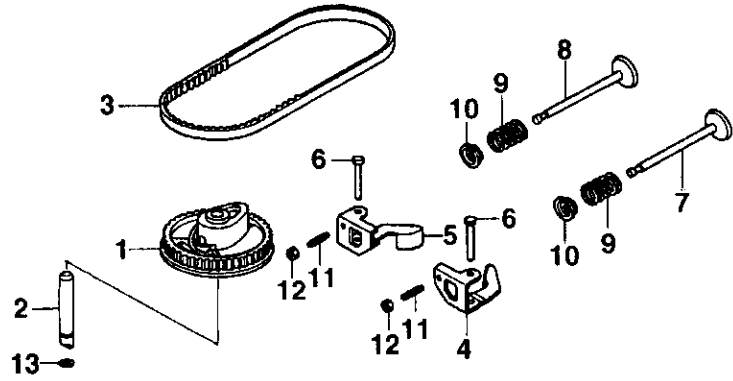

CARBURETOR

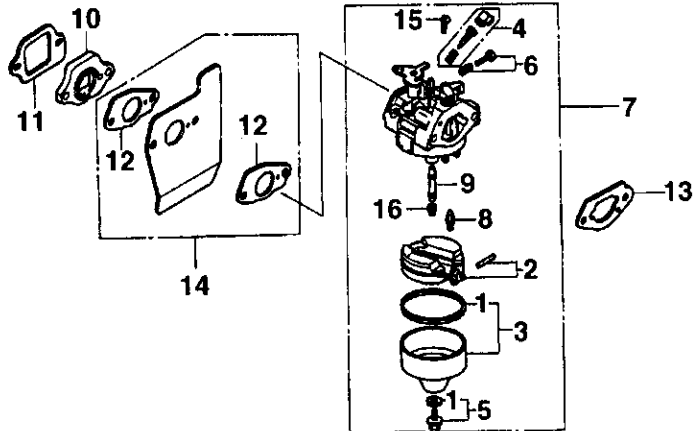

**CONTROL**

KEY NO.	PART NO.	DESCRIPTION
1	5580311	Arm, Governor
2	5580329	Rod, Governor
3	5580345	Spring, Governor
4	5580352	Spring, Throttle Return
5	4439428	Spring, Lever
6	0800466	Holder, Cable
7	5580378	Base Comp., Control Use up to SN 1177559.
7	6094122	Base Comp., Control Use from SN 1177560.
8	5580386	Rod, Governor
9	2418671	Bolt, Governor arm
10	5580998	Bolt, Flange (6X45) (CT200)
11	0145557	Screw Pan (5X16)
12	0471623	Nut Flange (6MM)

**CAMSHAFT PULLEY**

KEY NO.	PART NO.	DESCRIPTION
1	5580055	Pulley Comp., Camshaft
2	5580063	Shaft, Cam Pulley
3	5580071	Belt, Timing
4	5580089	Arm In. Valve Rocker
5	5580097	Arm Ex. Valve Rocker
6	5580105	Shaft Rocker Arm
7	5580113	Valve, In.
8	5580121	Valve, Ex.
9	5580139	Spring, Valve
10	1426980	Retainer, In. Valve Spring
11	0294819	Screw, Tappet Adj.
12	0004598	Nut, Tappet Adj.
13	0018044	O-ring

**CARBURETOR**

KEY NO.	PART NO.	DESCRIPTION
1	3088416	Gasket Set
2	5580162	Float Set
3	4930756	Chamber Set Float
4	4481818	Screw Set
5	1441518	Screw Set
6	5580170	Screw Set
7	5664552	Carburetor Assy.
8	5580212	Valve, Float
9	5580220	Nozzle, Main
10	5580238	Insulator, Carburetor
11	5580246	Gasket, Carburetor
12	4581120	Gasket, Carburetor
13	5580253	Gasket, Carburetor
14	5580535	Guide Comp., Air
15	3344520	Screw Pan (5X6)
16	0635474	Jet, Main #60 (OPTIONAL)
16	0635482	Jet, Main #62 (OPTIONAL)
16	0636126	Jet, Main #65 (OPTIONAL)

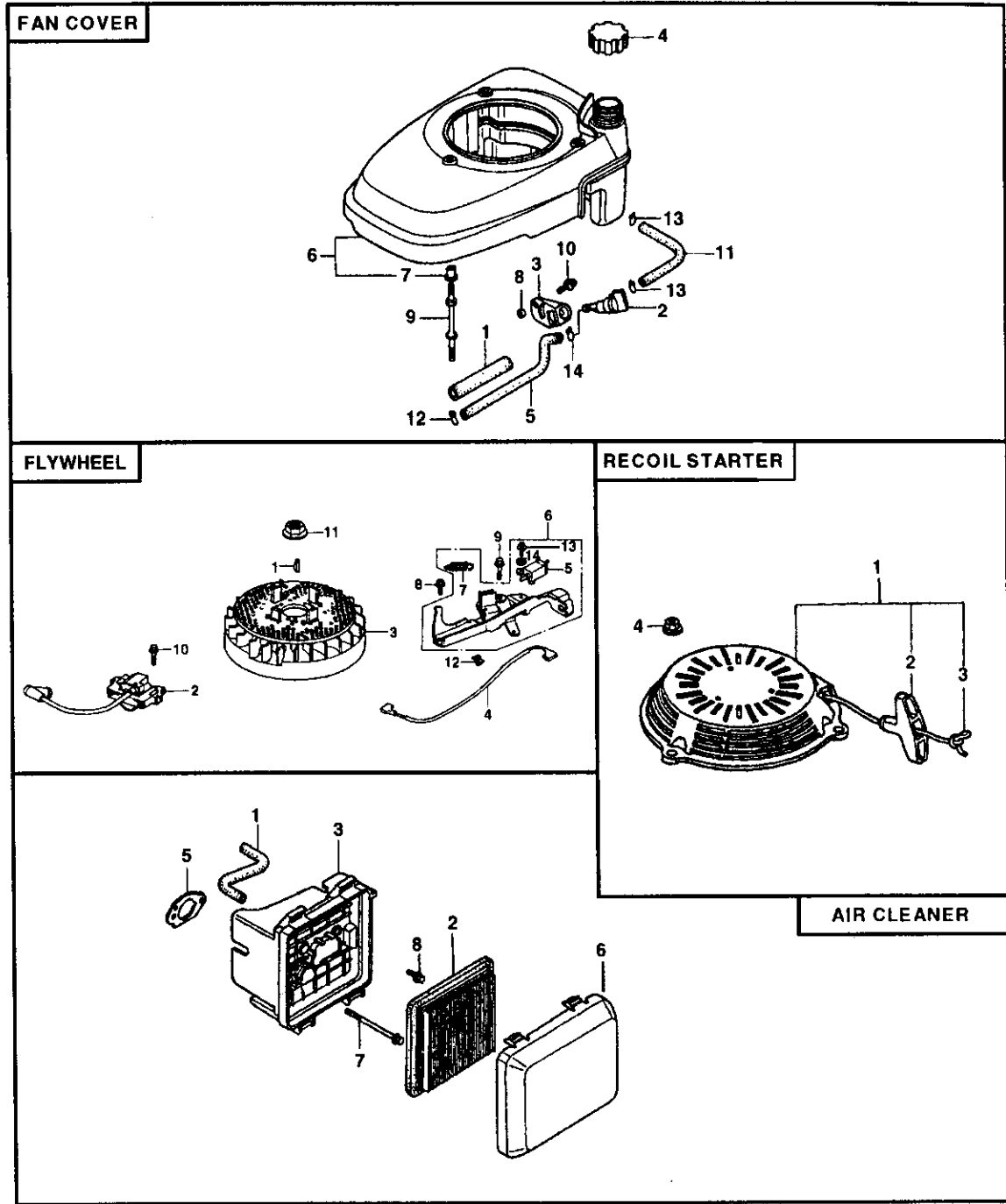

## FAN COVER

KEY NO.	PART NO.	DESCRIPTION
1	3683646	Rubber, Supporter 107 mm
2	5028923	Petcock Assy. Man
3	5580394	Bracket, Petcock
4	5580451	Cap Assy., Fuel Tank
5	5580469	Tube, Fuel
6	5580519	Cover Comp., Fan NH1 Black
7	5580527	Collar, Fan Cover
8	2499440	Collar, Fr. Turn Signal
9	5581004	Bolt, Stud
10	0671636	Screw-Washer 5X10
11	2449593	Bulk Hose, Fuel
12	0250647	Clip, Tube (B8)
13	0250985	Clip, Tube (B10)
14	0053447	Clip, Tube (C9)

## FLYWHEEL

KEY NO.	PART NO.	DESCRIPTION
1	0348433	Key, Special Woodruff (25X18)
2	5580659	Coil Assy., Ignition
3	5723747	Flywheel Assy.
4	5580675	Wire, Stop Switch
5	5580683	Switch Assy., Engine Stop
6	5580782	Brake Assy.
7	5580790	Spring, Brake Lever
8	0803619	Bolt Flange (6X14)
9	1725050	Bolt, Flange (6X23)
10	0671552	Bolt, Flange (6X20)
11	0442038	Nut, Special 14mm
12	1824630	Clip Cable
13	0485946	Screw-Washer (4X12)
14	1510361	Washer, Plain

## AIR CLEANER

KEY NO.	PART NO.	DESCRIPTION
1	5580154	Tube, Breather
2	5580402	Element, Air Cleaner
3	5581410	Case Assy., Air Cleaner
5	5664560	Gasket, Air Cleaner
6	5580444	Cover, Air Cleaner
7	5580964	Bolt, Flange (6X86)
8	2374742	Bolt, Flange (6X14)

## RECOIL STARTER

KEY NO.	PART NO.	DESCRIPTION
1	5597869	Starter Assy., Recoil NH1 Long Rope Black
2	5580634	Knob, Recoil Starter
3	5580642	Rope, Recoil Starter
4	2866341	Nut, Flange 6mm

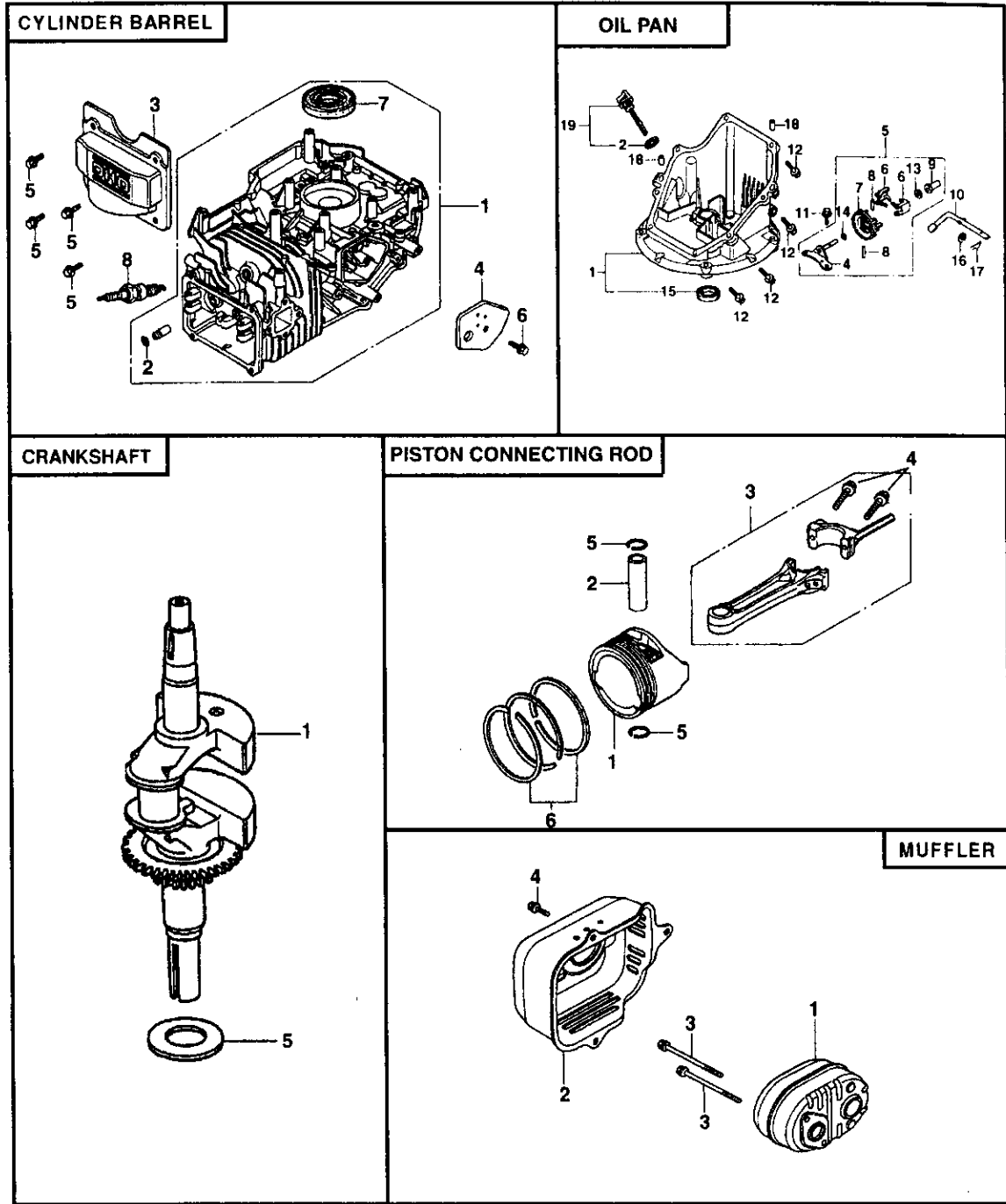



## CYLINDER BARREL

KEY NO.	PART NO.	DESCRIPTION
1	5579982	Cylinder Assy.
2	2399780	Clip, Valve Guide
3	5579990	Cover, Head
4	5580006	Cover Comp., Breather
5	0636845	Bolt, Flange (6X12)
6	0803619	Bolt, Flange (6X14)
7	5581038	Oil Seal 25.4X62X6
8	1441112	Spark Plug (BPR6ES NGK)

## PISTON CONNECTING ROD

KEY NO.	PART NO.	DESCRIPTION
1	5580014	Piston
2	1426576	Pin, Piston
3	5580022	Rod Assy., Connecting
4	1431055	Bolt, Connecting Rod
5	2605517	Clip, Piston Pin 13mm
6	5655949	Ring Set, Piston (Riken)
6	5655956	Ring Set, Piston (Teikoku)

## OIL PAN

KEY NO.	PART NO.	DESCRIPTION
1	5579974	Pan Assy., Oil
2	4497947	Gasket, Oil Filler Cap
4	5580261	Shaft Comp., Governor Holder
5	5580279	Governor Assy.
6	5580287	Weight, Governor
7	5580295	Holder, Governor Weight
8	1427244	Pin, Governor Weight
9	1427251	Slider, Governor
10	5580303	Shaft, Governor Arm
11	0803619	Bolt Flange (6X14)
12	0748111	Bolt, Flange (6X25)
13	2413862	Washer, Thrust 6mm
14	2456697	Clip, Governor Holder
15	5581046	Oil Seal (28X41.25X6)
16	0345900	Washer, Plain 6mm
17	0115527	Pin, Lock 8mm
18	1417369	Pin, Dowel (8X20)
19	5722996	Gauge Assy., Oil Level

## MUFFLER

KEY NO.	PART NO.	DESCRIPTION
1	5580485	Muffler Comp.
2	5580501	Protector, Muffler
3	5580972	Bolt, Flange (6X79) CT200
4	0636845	Bolt, Flange (6X12)
5	5737457	Gasket, Muffler (Optional)

## CRANKSHAFT

KEY NO.	PART NO.	DESCRIPTION
1	5580030	Crankshaft Comp. (N1-Type)
5	5581012	Washer Thrust





**For in-home major brand repair service:**

Call 24 hours a day, 7 days a week

**1-800-4-MY-Home<sup>SM</sup>** (1-800-469-4663)

**Para pedir servicio de reparación a domicilio**

**1-800-676-5811**

In Canada for all your service and parts needs call

Au Canada pour tout le service ou les pièces

**1-800-665-4455**

**For the repair or replacement parts you need:**

Call 6 am-11pm CST, 7 days a week

**PartsDirect<sup>SM</sup>**

**1-800-366-PART** (1-800-366-7278)

**Para ordenar piezas con entrega a domicilio**

**1-800-659-7084**

**For the location of a Sears Parts and Repair Center  
in your area:**

Call 24 Hours a day, 7 days a week

**1-800-488-1222**

**For information on purchasing a Sears Maintenance  
Agreement or to inquire about an existing Agreement:**

Call 9 am-5 pm, Monday - Saturday

**1-800-827-6655**

