

SEARS

OWNER'S MANUAL

Model No.
390.303302
390.303491

CAUTION:
Read and Follow
All Safety Rules and
Operating Instructions
Before First Use of
This Product.

Save This Manual For
Future Reference.

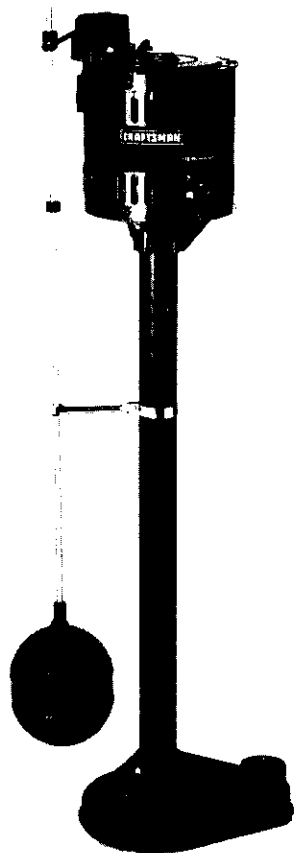

CRAFTSMAN
Model No. 390.303302

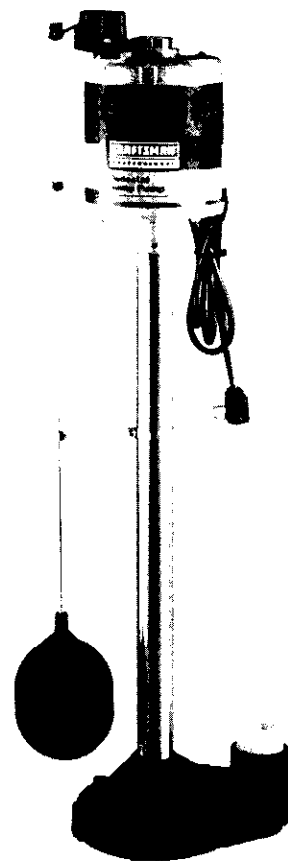

CRAFTSMAN PROFESSIONAL
Model No. 390.303491

CRAFTSMAN® PEDESTAL SUMP PUMP

- Safety Instructions
- Operation
- Installation
- Service
- Repair Parts

Sears, Roebuck and Co., Hoffman Estates, IL 60179 U.S.A.

CONTENTS

Introduction	2
Warranty	2
Safety Rules	2
Installation	3-5
Service	5
Repair Parts	6-7

INTRODUCTION

Please read our instructions before you install and use your new pump; this will help you obtain full value and good service from it. It will also help you avoid needless service costs that result from causes we cannot control and cannot cover in our warranty.

LIMITED LIFETIME WARRANTY on CRAFTSMAN® PROFESSIONAL 1/2-HP PEDESTAL SUMP PUMP

Provided that it is installed and operated according to the instructions in the owner's manual, if this pump ever fails for the original purchaser due to a defect in material or workmanship, return it to your nearest Sears store, and Sears will replace it free of charge. You pay for labor if you choose to have Sears install the replacement pump.

FULL ONE YEAR WARRANTY ON CRAFTSMAN® 1/3-HP PEDESTAL SUMP PUMP

For one year from the date of purchase, Sears will repair or replace this sump pump, free of charge, if defective in material or workmanship. This warranty does not cover repairs or replacement parts necessary because of abuse or negligence including failure to install, adjust and operate this pump according to the instructions in the owner's manual.

Warranty service is available by calling Sears at 1-800-4-MY-HOME®.

LIABILITY LIMITATION

Sears is not liable for loss or damage to property, nor for any incidental or consequential loss or expense from property damage, that results directly or indirectly from the use of this product. Some states do not allow the exclusion or limitation of property, incidental or consequential damages, so the above limitation or exclusion may not apply to you.

This warranty applies only while this product is used in the United States.

This warranty gives you specific legal rights, and you may also have other rights which vary from state to state.

Sears, Roebuck and Co., Dept. 817WA, Hoffman Estates, IL 60179

RULES FOR SAFE INSTALLATION AND OPERATION

Carefully read and follow all safety instructions in this manual or on pump.

⚠ This is the safety alert symbol. When you see this symbol on your pump or in this manual, look for one of the following signal words and be alert to the potential for personal injury!

⚠ DANGER warns about hazards that will cause serious personal injury, death or major property damage if ignored.

⚠ WARNING warns about hazards that can cause serious personal injury, death or major property damage if ignored.

⚠ CAUTION warns about hazards that will or can cause minor personal injury or property damage if ignored.

The word **NOTICE** indicates special instructions which are important but not related to hazards.

Electrically powered sump pumps normally give many years of trouble-free service when correctly installed, maintained, and used. However, unusual circumstances (interruption of power to the pump, dirt/debris in the sump, flooding that exceeds the pump's capacity, electrical or mechanical failure in the pump, etc.) may prevent your pump from functioning normally. To prevent possible water damage due to flooding, consult your local Sears store about installing a secondary sump pump or a DC backup sump pump. See "Service", Page 5, for information about common sump pump problems and remedies.

NOTICE: This unit is not designed for applications involving salt water or brine! Use with salt water or brine will void warranty.

1. Read these Instructions and Safety Rules carefully. Failure to follow them could cause serious bodily injury and/or property damage.
2. Check your local Electrical and Plumbing Codes before installing pump. You must comply with their rules.

⚠ WARNING Do not use in explosive atmospheres. Pump water only with this pump.

Do not touch an operating motor. Modern motors are designed to run at high temperatures.

⚠ WARNING Risk of electric shock. Proceed as follows if pump needs servicing:

- A. Disconnect power to pump outlet box before pulling pump cord plug! After plug is pulled, let pump cool for 20 minutes before attempting to work on it.
 - B. Take extreme care when changing fuses. To reduce the chance of fatal electrical shocks, **DO NOT** stand in water or put your finger in the fuse socket.
 - C. Ground the electrical outlet box.
 - D. Use only a grounded outlet for cord plug.
 - E. Do not handle pump motor with wet hands or when standing on wet or damp surface, or in water.
3. Never run pump dry. To do so can damage internal parts, overheat the pump (which can cause burns to people handling or servicing the pump), and will void the warranty!

⚠ WARNING FIRE HAZARD – Do not store or rest objects on or near motor or switch linkage. Keep all flammable objects or liquids away from motor.

4. This pump is recommended for use in permanent installations only. Do not install on clay, earth, or sand surfaces.

▲ CAUTION Pump must be level (column must be vertical) when operating. If motor is tilted, internal start/run switch may overheat and damage motor.

ADDITIONAL INSTALLATION MATERIALS

Sump/Utility Pump Hose Kit, SEARS Stock No. 27909, containing 24' of 1-1/4" flexible plastic pipe, a 1-1/4" plastic adapter and a stainless steel clamp.

Check Valve, SEARS Stock No. 2789 or 2792.

THE SUMP

The sump should be located at the lowest place in the basement or area to be drained. Floor drains from other areas in the basement may be tiled into the sump. Drain tile around a house foundation can also be tiled into the sump, effectively removing water and relieving pressure from this area. A suitable sump can be a 20" or 24" sewer tile. Sump must be at least 12" in diameter.

A sump cover is desirable to exclude refuse from the sump. Consult local code for sump cover specifications.

SPECIFICATIONS

Power supply required	115V, 60 HZ.
Horsepower (390.303302)	1/3
Horsepower (390.303491)	1/2
Motor duty	Intermittent
Liquid Temp. Range	32° F to 70° F (0°-21°C)
Individual Branch Circuit Requirement GFCI Class A	15 Amps
Motor full load (maximum - 390.303302)	3.5 Amps
Motor full load (maximum - 390.303491)	7.3 Amps
Discharge (390.303302)	1-1/4" NPT
Discharge (390.303491)	1-1/2" NPT

PUMP INSTALLATION

Check your local Electrical and Plumbing Codes before installing pump. You must comply with their rules.

Set the pump on the bottom of the sump, making sure that it sits solidly and is level. Be sure there is enough space around the pump to allow the switch free movement as the sump water level changes. Do not install on clay, earth, or sand.

▲ CAUTION Risk of flooding. If a flexible discharge hose is used, pump may move around in sump when motor starts. If it moves far enough so that the switch hits the side of the sump, the switch may stick and prevent pump from starting. Make sure that pump is secured so that it cannot "walk around" in sump.

NOTE: To avoid backflow into the sump when the pump shuts off, install a Check Valve, SEARS Stock No. 2789, in the threaded discharge port of pump (390.303302) or 1-1/2" x 1-1/4" reducer bushing (390.303491). Reducer bushing is included with Model 390.303491. Be sure arrow on check valve body points away from the pump. This Check Valve is equipped with an air bleed hole to prevent airlocking the pump. If using any other check valve, drill 1/8" (3.2 mm) hole in discharge pipe just above pump body but below check valve to prevent air locks.

Use 1-1/4" plastic pipe from Hose Kit No. 27909 for the discharge pipe. Run the discharge pipe to the nearest sewer outlet or other point of disposal. Use the most direct route with the fewest turns and elbows possible.

Use Teflon tape to seal threads in plastic pipe. Hand tighten only.

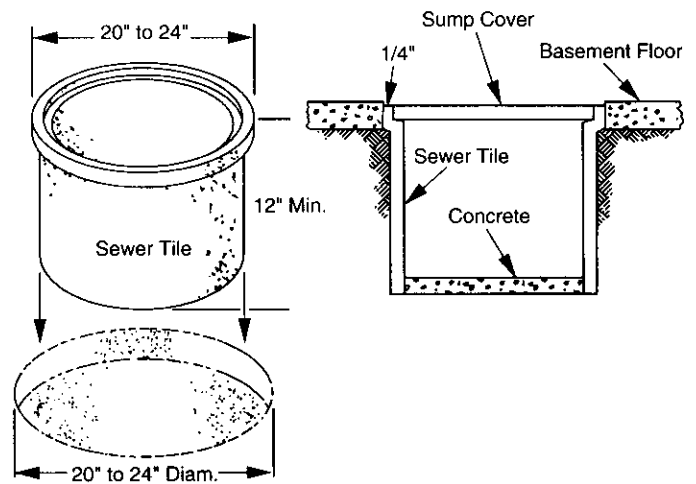

Figure 1

ROD AND FLOAT SWITCH INSTALLATION

See Figure 2 for stop positions.

1. Thread float rod into float until it is firmly hand tight.
2. Slide rod guide over float rod; follow it with a rod stop bushing (A) set about eight inches down from the top of the rod.
3. Slide float rod up through the eye in the switch arm. Add a rod stop bushing (B) at the top of the rod.
4. Open large loop on rod guide and mount it around the column. Fasten with screw, making sure that the float rod hangs vertically from the switch and moves freely in the rod guide. Make sure the rod guide is tightly clamped.
5. Adjust rod stop bushings for designed level control.
6. Lift the rod up and down to be sure the switch will click and that the arm does not bind on the rubber bushings. The rod must also move freely in the guide.
7. Fill the sump and run pump through one complete cycle to check switch operation.

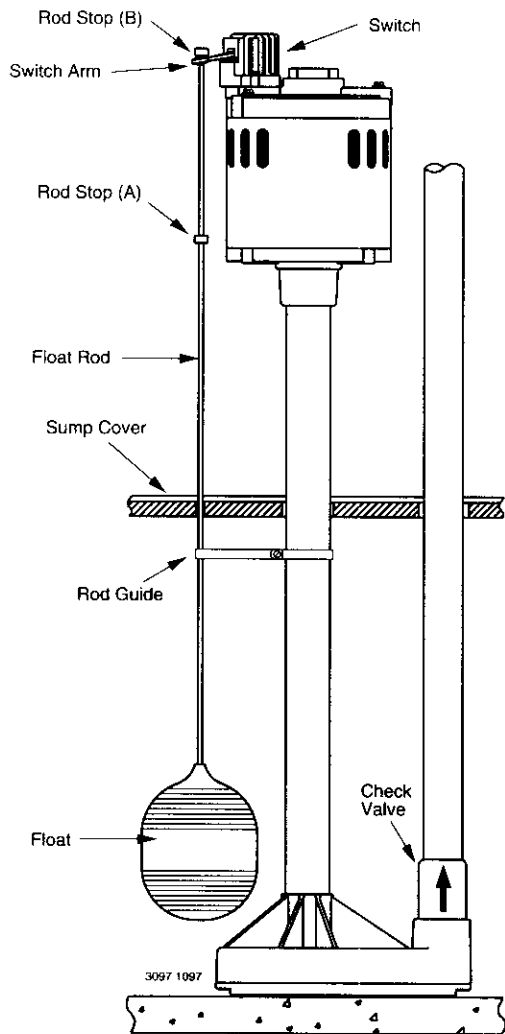

Figure 2

The switch unit operates as follows:

1. When the sump is dry, the float rod hangs from the switch arm. Its weight holds the switch off.
2. When the water rises in the sump, the float lifts the switch rod. The buoyancy will push the switch arm up and turn the switch on.
3. When the water is pumped out of the sump, the float drops down again. The weight of the float will allow the rod and switch arm to lower and turn the drainer switch off.

DO NOT ALLOW PUMP TO RUN DRY

Pump should not be allowed to run dry prior to shutting off. To do so voids the warranty and could ruin the pump.

If necessary, adjust the float so this will not happen.

ELECTRICAL CONNECTIONS

▲WARNING Risk of electric shock. The Sump Pump has a 3-prong electric plug. The third prong is used to ground the pump to prevent possible fatal shock. The third prong should never be removed. Your electrical outlet should be the 3-prong, polarized type with an internal ground.

Pump must be wired into a 15 amp GFCI protected individual branch circuit.

DO NOT USE AN EXTENSION CORD.

Testing for Ground

For your safety, check your outlet for ground using a Circuit Analyzer, (Figure 3). A Circuit Analyzer will tell you by a pattern of lights if the power, neutral, and ground wires are correctly connected to your outlet. It can also be used to check other outlets in your home. A Circuit Analyzer is available in the SEARS Electrical Department.

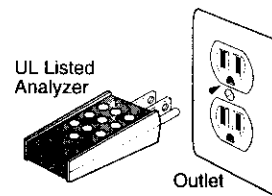

Figure 3

665 0194

Grounding Outlet

If outlet is not grounded, install a copper wire (at least 14 gauge) from the outlet box, as shown in Figure 4, to a metal cold water pipe. Use ground clamp on pipe.

IMPORTANT: The cold water pipe you use as a ground must have metal continuity to electrical ground. If continuity is interrupted by plastic, rubber, or other electrical insulators; such as hoses, fittings, washers or gaskets (including water meter or pump), a metal bypass must be used. Any electrically insulated connector should be jumped (as shown in Figure 5), with a length of No. 4 wire clamped securely at both ends.

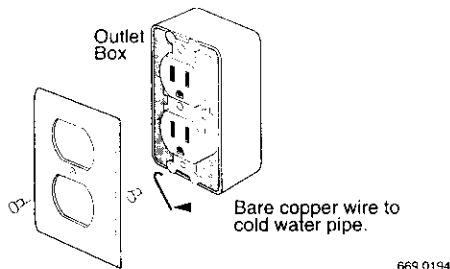

Figure 4

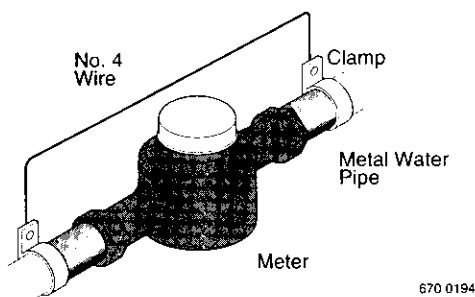

Figure 5

Automatic Thermal Overload Protection

This pump motor has a built-in automatic thermal overload protector. If the motor overheats, the protector will open and cut off power to the motor before the heat damages it internally. The overload will reset automatically and the pump will restart after the pump cools down below the danger point.

WARNING DO NOT attempt to work on the pump or motor if the overload seems to have tripped. The motor may restart without warning at any time. You could be injured and the pump damaged if it starts when you are working on it.

DO NOT attempt to repair a sump pump. Take it to SEARS for service by a qualified technician.

GENERATOR SIZING

Below is the Engine-Generator Watt rating required to power this pump motor. Any additional loads, such as lights, must be added to the listed load and the generator sized accordingly.

Pump Motor HP	Minimum Watt Rating of Generator
1/3	2,200
1/2	2,800

SERVICE

General

WARNING Risk of electric shock. When servicing pump always disconnect power to electrical outlet and remove pump electric cord from outlet. Inspect sump pump and system components monthly. Keep free of debris and foreign objects.

1. If pump does not operate:
 - a. Check for loose plug at electric outlet.
 - b. Check for blown fuses or tripped circuit breakers at fuse box/circuit breaker box.
 - c. Be sure nothing interferes with action of float switch.
 - d. If a, b, and c above check OK, plug in a light that you know works. If it lights, take your pump to SEARS for service. If it doesn't light, the electrical circuit is faulty; consult a licensed electrician.
2. Pump starts, but blows fuses/trips circuit breakers:

After disconnecting power to pump, remove it from sump. Remove the plate from the bottom of the pump and make sure that the impeller turns freely. Remove any debris obstructing impeller. If pump still does not operate correctly, return it to your nearest SEARS Service Department for repairs.
3. Pump runs, but does not empty sump:
 - a. Clean pump intake screen.
 - b. Water may be entering sump faster than the pump can discharge it.
 - c. Be sure vertical distance from pump discharge outlet to discharge pipe outlet is 18 feet or less for Model 390.303302 (20 feet or less for Model 390.303491).
 - d. Be sure discharge pipe is not plugged or frozen.

LUBRICATION

Motor has been lubricated at the factory. It does not require additional oil. Bronze bearing in volute housing is oil impregnated. It does not require additional oil.

Craftsman Model 390.303302

To order parts, call:
Sears Product Service
1-800-366-7278

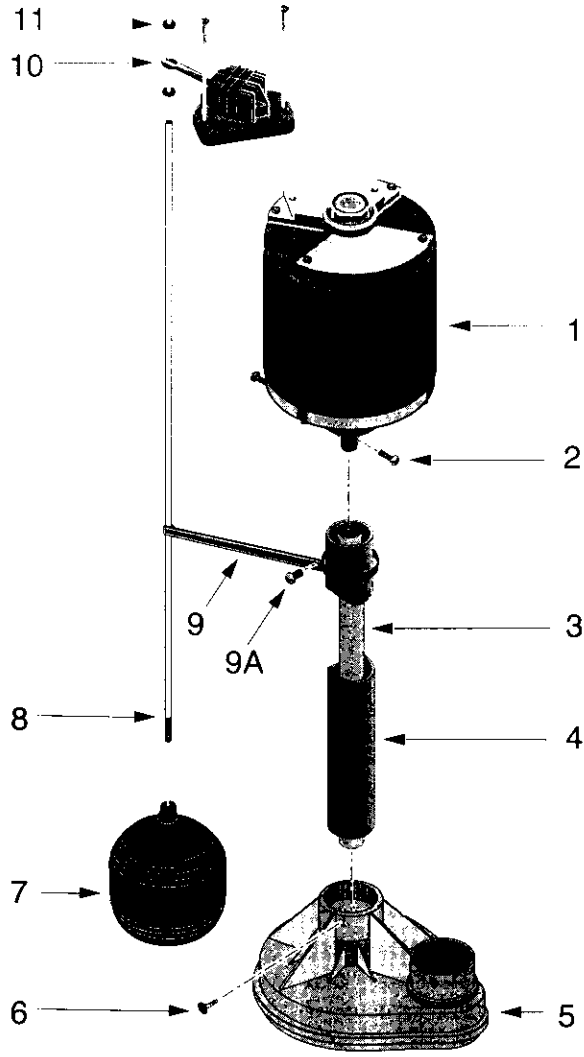

659 0594

Key No.	Part Number	Description
1	**	Motor with Cord and Switch
2	U30-932ZP	Screw #8 x 1/2" Hex Head (2 Required)
3	RP0005257	Shaft
4	RP0005246A	Column
5	S101-33P	Impeller Assembly
6	SC004-116	Screw #8-18 x 3/8 Self Tap
7	FT0013-63	Float
8	RP005168S	Rod
9	RP0005249	Rod Guide
9A	U30-929ZP	Screw #8 x 1" Phillips Head
10	2773	Switch
11	RP0005248	Float Stop (2 Required)
•	U17-318	Cord and Plug

• Not illustrated.

** If motor fails, replace entire pump.

Craftsman Professional Model 390.303491

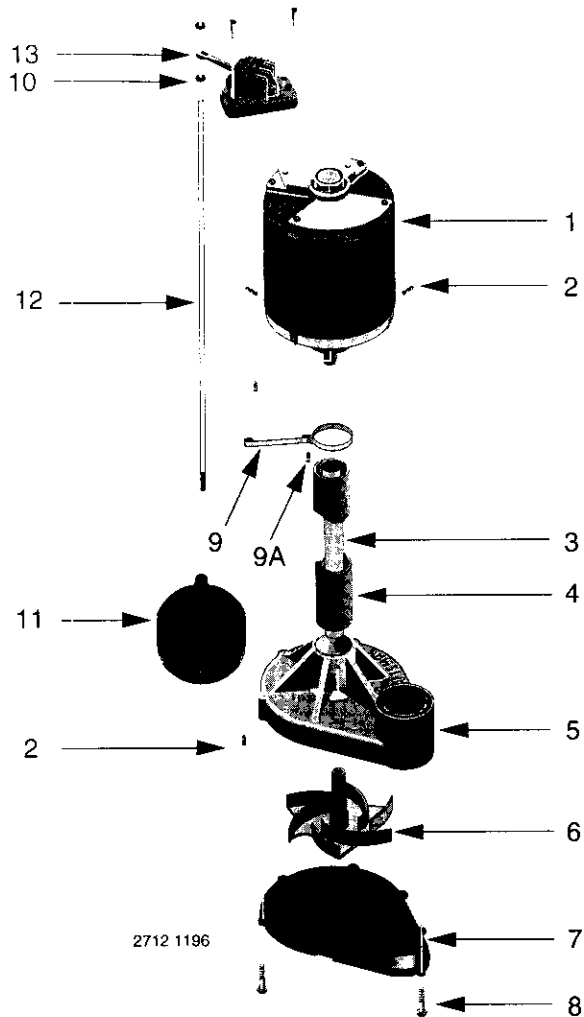

To order parts, call:
Sears Product Service
1-800-366-7278

2712 1196

Key No.	Part Number	Description
1	**	Motor with Cord and Switch
2	U30-946PH	Set Screw (4 Required)
3	RP0005257	Shaft
4	S15-37SS	Column
5	S1-32B	Volute
6	S5-13P	Impeller
7	PS4-17P	Base Plate
8	U30-571BT	Screw #8-32 x 1/2 Hex Head (8 Required)
9	RP0005249	Rod Guide
9A	U30-929ZP	Screw #8x1" Phillips Head
10	RP0005248	Rod Bushing (2 Required)
11	FT0013-63	Float
12	RP005168S	Rod
13	2773	Switch
•	U17-318	Cord and Plug
•	U78-130P*	1-1/2" x 1-1/4" Reducer Bushing

• Not illustrated
* May be purchased locally.
** If motor fails, replace entire pump.

SEARS

OWNER'S MANUAL

Model No.
390.303302
390.303491

The model number of your Pedestal Sump Pump will be located on the side of the motor.

When requesting service or ordering parts, always give the following information:

- Product Type
- Model Number
- Part Number
- Part Description

CRAFTSMAN[®] PEDESTAL SUMP PUMP

For the repair or replacement parts you need
Call 7 am - 7 pm, 7 days a week
1-800-366-PART
(1-800-366-7278)

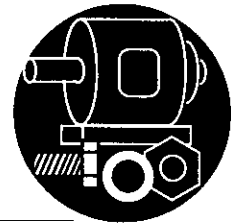

For in-home major brand repair service
Call 24 hours a day, 7 days a week
1-800-4-REPAIR
(1-800-473-7247)



For the location of a
Sears Repair Service Center in your area
Call 24 hours a day, 7 days a week
1-800-488-1222



For information on purchasing a Sears
Maintenance Agreement or to inquire
about an existing Agreement
call 9 am - 5 pm, Monday-Saturday
1-800-827-6655



SEARS
REPAIR SERVICES
America's Repair Specialists

Sears, Roebuck and Co., Hoffman Estates, IL 60179 U.S.A.