

INSIGNIA™

USER GUIDE

v1  
R2

# Universal Rear Speaker Kit

NS-HURSK18

FPO

Before using your new product, please read these instructions to prevent any damage.

## Contents

Introduction .....	2
Important safety instructions .....	2
Package contents .....	5
Features .....	6
Speakers .....	6
Transmitter .....	7
Receiver .....	8
Remote control .....	9
Using the remote control .....	10
Programming a universal remote .....	10
Setting up your speakers .....	11
Step 1 - Choosing your connection .....	11
Step 2 - Connecting the transmitter .....	11
Step 3 - Connecting the speakers to the receiver .....	12
Step 4 - Connecting the AC adapter .....	13
Step 5 - Connecting the receiver to the transmitter .....	14
Positioning the speakers .....	15
Using your speakers .....	16
Maintaining your speakers .....	17
Replacing the remote control battery .....	17
Troubleshooting .....	18
Specifications .....	19
Legal notices .....	19
ONE-YEAR LIMITED WARRANTY .....	21

## Introduction

Congratulations on your purchase of an Insignia Universal Rear Speaker Kit. It features a variety of connections and a remote control for easy operation. This user guide explains how to correctly install, operate, and get the best performance from your speaker kit. Read this user guide carefully before installing your system, and then keep it handy for quick reference.

## Important safety instructions

- 1 Read these instructions.
- 2 Keep these instructions.
- 3 Heed all warnings.
- 4 Follow all instructions.

- 5 Do not use this apparatus near water.
- 6 Clean only with dry cloth.
- 7 Do not block any ventilation openings. Install in accordance with the manufacturer's instructions.
- 8 Do not install near any heat sources such as radiators, heat registers, stoves, or other apparatus (including amplifiers) that produce heat.
- 9 Do not defeat the safety purpose of the polarized or grounding-type plug. A polarized plug has two blades with one wider than the other. A grounding type plug has two blades and a third grounding prong. The wide blade or the third prong are provided for your safety. If the provided plug does not fit into your outlet, consult an electrician for replacement of the obsolete outlet.
- 10 Protect the power cord from being walked on or pinched particularly at plugs, convenience receptacles, and the point where they exit from the apparatus.
- 11 Only use attachments/accessories specified by the manufacturer.
- 12 Use only with the cart, stand, tripod, bracket, or table specified by the manufacturer, or sold with the apparatus. When a cart is used, use caution when moving the cart/apparatus combination to avoid injury from tip-over.
- 13 Unplug this apparatus during lightning storms or when unused for long periods of time.
- 14 Refer all servicing to qualified service personnel. Servicing is required when the apparatus has been damaged in any way, such as when the power-supply cord or plug is damaged, liquid has been spilled or objects have fallen into the apparatus, the apparatus has been exposed to rain or moisture, does not operate normally, or has been dropped.
- 15 To reduce the risk of fire or electric shock, do not expose this device to rain, moisture, dripping, or splashing, and no objects filled with liquids, such as vases, shall be placed on it.
- 16 An apparatus with a three-prong, grounding-type plug is a Class I apparatus, which needs to be grounded to prevent possible electric shock. Make sure that you connect any Class I device to a grounding-type, three-prong outlet.
- 17 DO NOT overload wall outlets or extension cords beyond their rated capacity as this can cause electric shock or fire.
- 18 The wall plug is the disconnecting device. The plug must remain readily operable.
- 19 No naked flame sources, such as lighted candles, should be placed on the apparatus.
- 20 The ventilation should not be impeded by covering the ventilation openings with items, such as newspapers, tablecloths, curtains, etc.



- 21 The remote control supplied with this product contains a coin/button cell battery. If the coin/button cell battery is swallowed, it can cause severe internal burns in just two hours and can lead to death.
- 22 Batteries should not be exposed to excessive heat such as sunshine, fire, or the like.

**Warning**

Danger of explosion if the remote control battery is incorrectly replaced. Replace only with the same or equivalent type.

- 23 Keep new and used batteries away from children.
- 24 If the battery compartment does not close securely, stop using the product and keep it away from children.
- 25 If you think batteries might have been swallowed or placed inside any part of the body, seek immediate medical attention.



The lightning flash with arrowhead symbol within an equilateral triangle is intended to alert the user to the presence of uninsulated "dangerous voltage" within the product's enclosure that may be of sufficient magnitude to constitute a risk of electrical shock to persons.



The exclamation point, within an equilateral triangle, is intended to alert the user to the presence of important operating and maintenance (servicing) instructions in the literature accompanying the product.

## Placement

- The speaker cabinets are made out of plastic and are therefore sensitive to extreme temperatures and humidity. Do not put it in locations subject to direct sunlight or in humid places, such as near an air conditioner, humidifier, bathroom, or kitchen.
- Do not put water or other liquids close to the speakers. If liquid is spilled on top of the speakers, they may be damaged.
- The speakers should be placed on a sturdy, flat surface that is free from vibration, or mounted on a wall. Do not put the speakers on an uneven or unstable surface, where they may fall and cause damage.

## Using close to a TV or computer

Some older TVs and computer monitors are magnetically sensitive devices. They are likely to suffer discoloration or picture distortion when conventional speakers are placed nearby. If discoloration problems persist, try moving the speakers away from your TV or monitor.

# Package contents

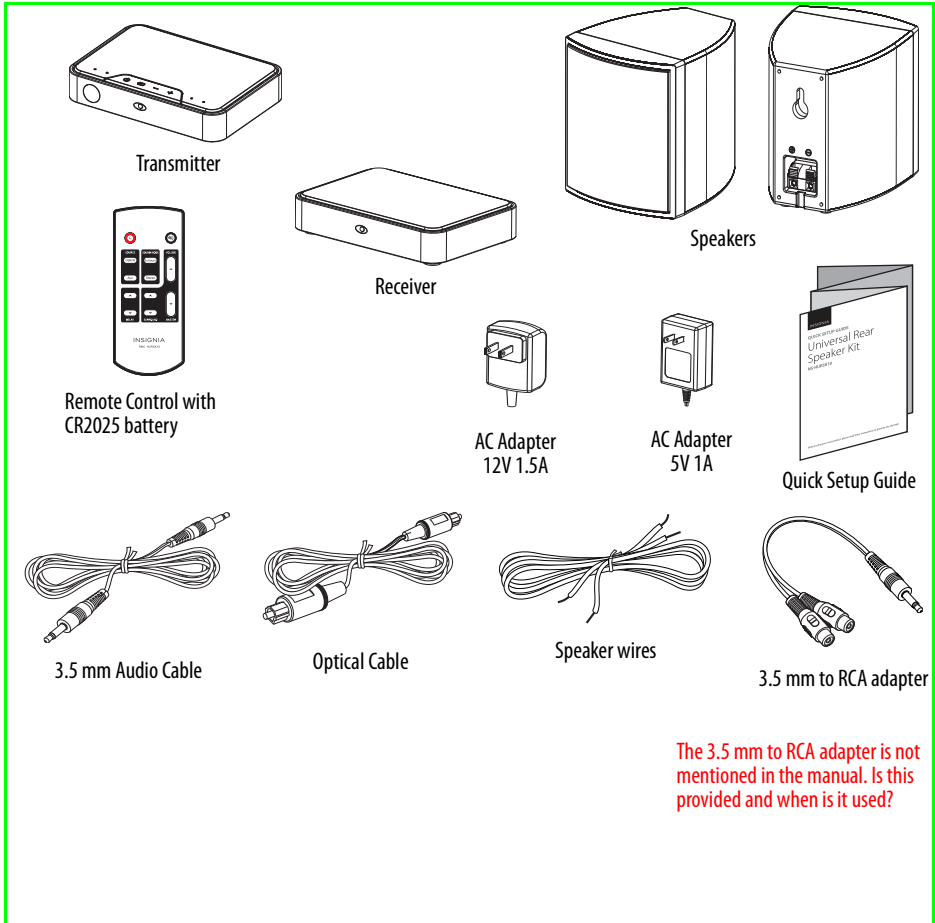

The 3.5 mm to RCA adapter is not mentioned in the manual. Is this provided and when is it used?

## Features

### Speakers

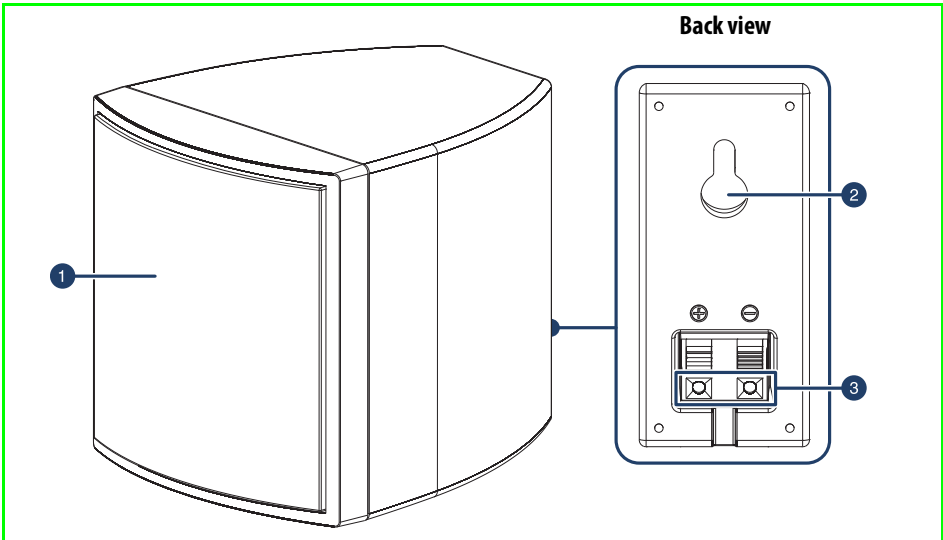

#	ITEM	DESCRIPTION
1	Speaker	Produces sound.
2	Hanging hole	Used to hang your speaker on a wall.
3	Speaker jacks	Connect speaker wires from the receiver (red wires to red jacks and black wires to black jacks) to the speakers here.

## Transmitter

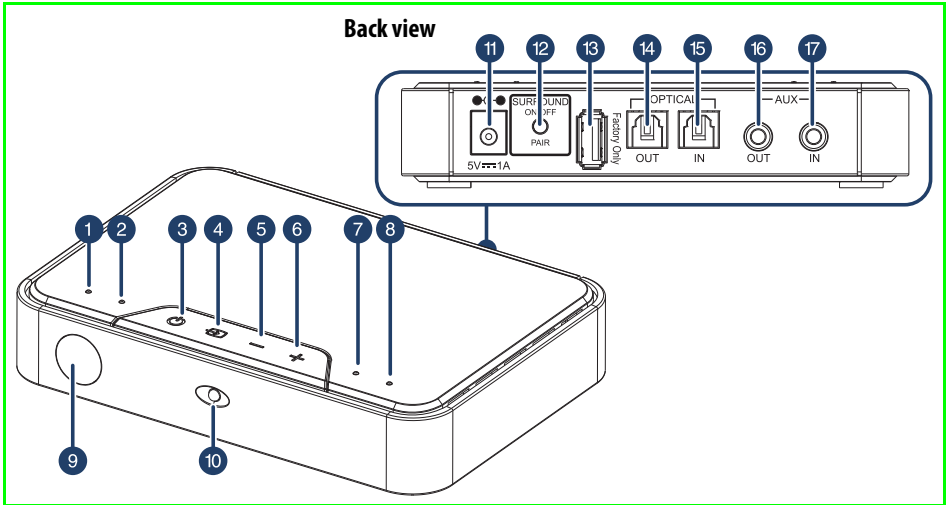

#	ITEM	DESCRIPTION
1	Optical indicator LED	Lights when using an optical (TV or DVD) sound source (default).
2	AUX indicator LED	Lights when using an AUX (tablet or mobile device) sound source.
3	⏻ (power) button	Press to turn on the transmitter. Press again to put the transmitter into standby mode.
4	↔ (source) button	Press to toggle between the optical and aux sound sources.
5	- (volume down)	Press to lower the volume.
6	+ (volume up)	Press to raise the volume.
7	Dolby indicator LED	Lights when the audio has <b>Dolby 5.1</b> content.
8	PCM indicator LED	Lights when the <b>PCM</b> audio is being received.
9	IR sensor	Aim the remote control at this sensor to control the transmitter.
10	Power indicator	- Lights red when the transmitter is in standby mode. - Blinks red when the transmitter is muted. - Turns off when the transmitter is turned on.
11	<b>DC IN</b> jack	Connect the 5V 1A AC adapter to this jack to power the transmitter.
12	Pairing button	Press <b>and hold</b> to pair the transmitter to the receiver.
13	Factory only	DO NOT USE. This jack is for factory use only.
14	Optical out jack	Connect your sound bar to this jack with a digital optical cable (included).
15	Optical in jack	Connect your TV or DVD player to this jack with a digital optical cable (included).
16	AUX out jack	Connect your sound bar to this jack with a 3.5 mm cable (included).
17	AUX in jack	Connect your TV or DVD player to this jack with a 3.5 mm cable (included).

Receiver

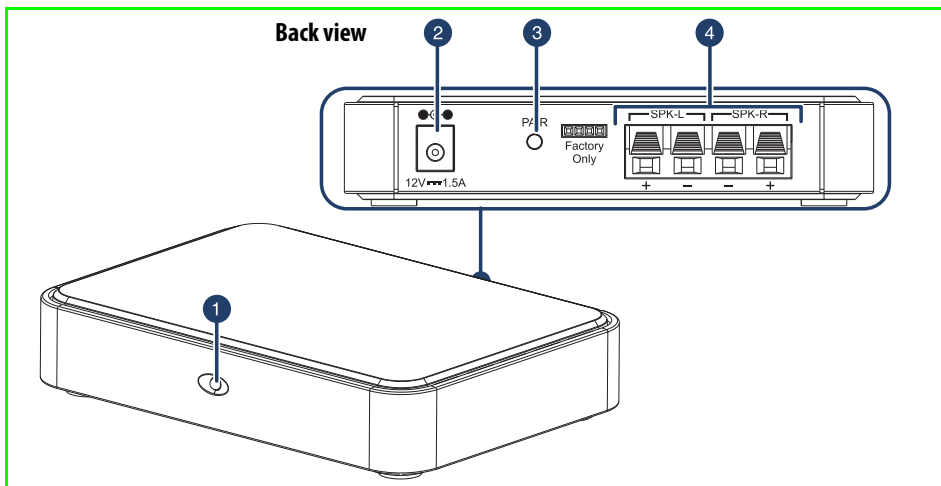

#	ITEM	DESCRIPTION
1	Power indicator	<ul style="list-style-type: none"> <li>- Lights blue when the receiver is on and paired with the transmitter.</li> <li>- Blinks blue when the receiver is in pairing mode.</li> <li>- Turns off when the receiver is turned off.</li> </ul>
2	DC IN jack	Connect the 12V 1.5A AC adapter to this jack to power the receiver.
3	Pairing button	Press <b>and hold</b> to pair the receiver to the transmitter.
4	Speaker jacks	Connect speaker wires from these jacks (red wires to red jacks and black wires to black jacks) to the speakers.



## Remote control

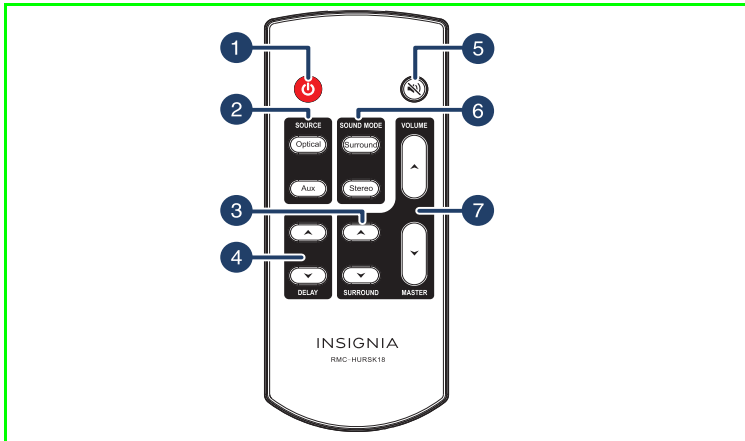

#	BUTTON	DESCRIPTION
1	⏻ (Power)	Press to turn on the speakers. Press again to put the speakers into standby mode.
2	<b>SOURCE</b>	Press to select the <b>OPTICAL</b> or <b>AUX</b> sound source.
3	<b>SURROUND</b>	Press + to increase the surround effect or - to decrease the surround effect.
4	<b>DELAY</b>	Press + to increase the sound delay or - to decrease the sound delay. <i>(Please explain)</i>
5	🔇 (Mute)	Press to mute the sound from the speakers. Press again to restore the sound.
6	<b>SOUND MODE</b>	Press to select the <b>SURROUND</b> or <b>STEREO</b> sound mode.
7	<b>MASTER VOL +/-</b> buttons	Press to increase or decrease the volume of the speakers.

## Using the remote control

- 1 Remove the plastic tab from the battery compartment before using the remote control for the first time.
- 2 Point the remote control directly at the IR sensor on the front of the transmitter. You must be within approximately 23 ft. (7 m) of the transmitter.

### Cautions

- Do not spill water or any liquid on the remote control.
- Do not place the remote control on a wet surface.
- Do not place the remote control in direct sunlight or near sources of excessive heat.
- If the remote control is not going to be used for a long time, remove the battery to avoid any damage that may be caused by leakage and corrosion.

## Programming a universal remote

### Note

To control your speakers' volume you can use an Insignia TV remote or program a universal remote. Insignia TV remotes and universal remotes will not be able to change your speakers' audio source or DSP sound mode. Use the controls on your speakers or the remote that came with it to change these settings.

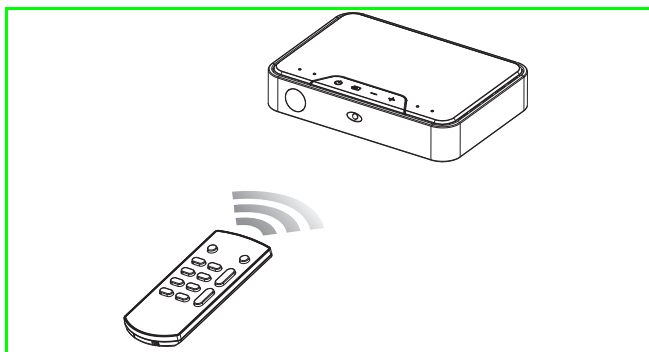

If you program your universal remote to an Insignia TV, it will control your speakers' volume. To program your remote:

- 1 Go to [www.insigniaproducts.com/remotecodes](http://www.insigniaproducts.com/remotecodes).
- 2 Find your remote's brand from the list of remote codes.

- Follow the directions that came with your remote to program a remote code. If several remote codes are provided, you may need to try several until you find one that works.

**Note**

Make sure that you program the speakers to a device on your remote that is not in use.



## Setting up your speakers

### Step 1 - Choosing your connection

- Look at the back of your sound source device, such as a TV, DVD/Blu-ray player, cable box, tablet, or mobile device to identify your audio OUT ports. Choose the connection option below that fits your audio source. You can connect several devices and switch the sound source as required.

**Caution**

Turn off or unplug all devices while you are making connections.

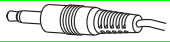
AUDIO QUALITY	JACK TYPE	CABLE	
<b>Best</b>			Digital Optical cable (included). See "Digital Optical connection (best)" on page 11.
<b>Good</b>			3.5 mm to 3.5 mm cable (included). See "AUX connection (good)" on page 12.

### Step 2 - Connecting the transmitter

#### Digital Optical connection (best)

- Connect one end of the digital optical cable (included) to the transmitter.
- Connect the other end into the **Digital Optical Output** port on your audio source device.

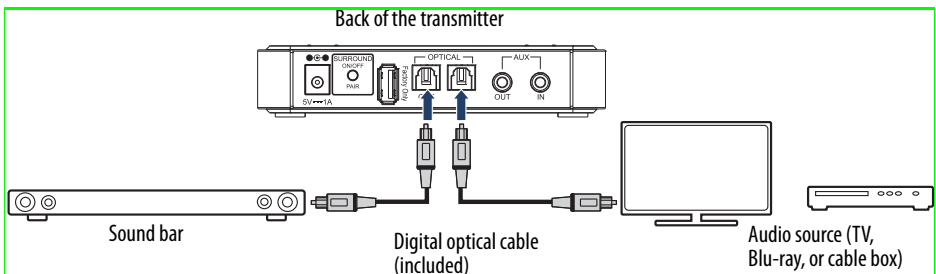

- Change the device's audio output to **RAW** format (typically found in audio settings). Refer to the documentation that came with your audio source device for more information.

### AUX connection (good)

- 1 Connect one end of the included 3.5 mm audio cable (included) to the transmitter.
- 2 Connect the other end of the 3.5 mm audio cable into the **Audio Output** ports on your audio source device, such as a tablet or mobile device.

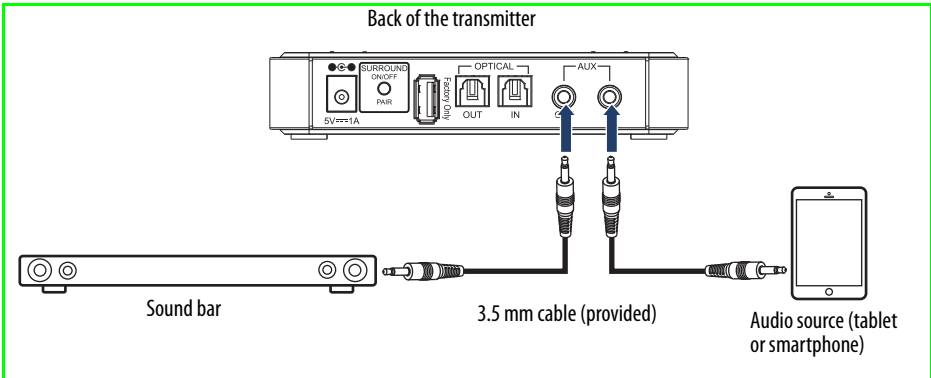

### Step 3 - Connecting the speakers to the receiver

- 1 Connect one end of the speaker wires (included) to the jacks on the back of the speakers, red wires to red jacks and black wires to black jacks.
- 2 Connect the other end of the speaker wires to the **SPK-L** (left speaker) and **SPK-R** (right speaker) jacks on the back of the receiver, red wires to red jacks and black wires to black jacks.

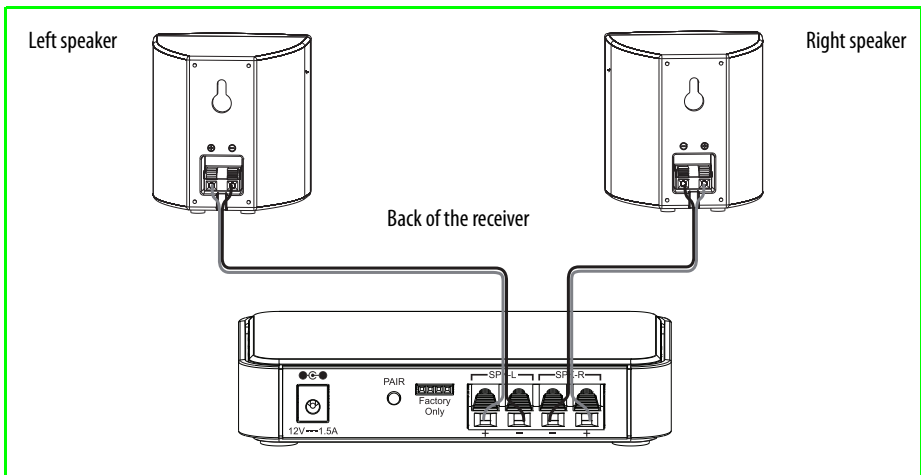

## Step 4 - Connecting the AC adapter

### Cautions

- Make sure that the electrical outlet matches the AC adapter's input requirements of 100-240 V, 50/60 Hz before connecting.
- Use only the AC adapter provided for the device specified.
- Plug in the AC adapter only after all other connections have been made.

- 1 Connect the 5V 1A AC adapter to the DC IN jack on the back of the transmitter.

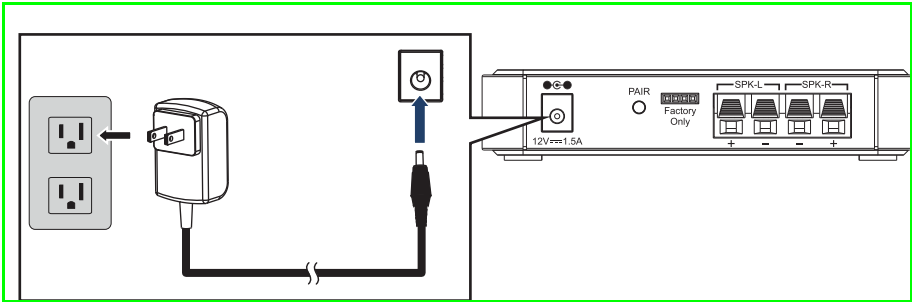

- 2 Connect the 12V 1.5A AC adapter to the DC IN jack on the back of the receiver.

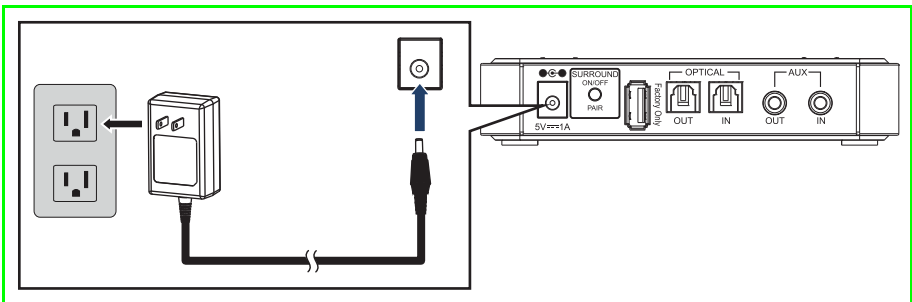

- 3 Plug the other end of the AC adapters into a power outlet or surge protector.

## Step 5 - Connecting the receiver to the transmitter

Before you can use your speakers, you need to pair the transmitter to the receiver.

### Note

Place the transmitter and receiver within 30 ft. (10 m) of each other.

### Pairing your devices

- 1 Turn on the transmitter and receiver.
- 2 Press and hold the **Pairing** button on the back of the receiver for three seconds. When paired, the LEDs light solid blue.

### Disconnecting your devices

- Turn off the transmitter and receiver.

## Positioning the speakers

### Warning

Improper installation can result in serious injury or damage to your speakers. If necessary, seek the assistance of a professional.

### Cautions

If you are installing screws into drywall or concrete, use wall anchors designed for that type of surface.

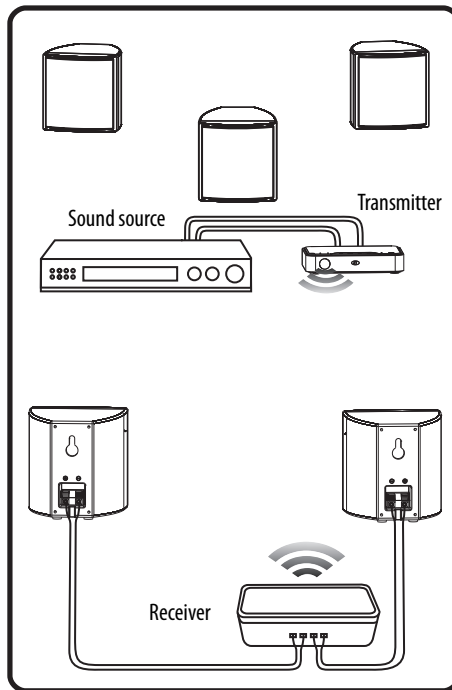

You can set the speakers on a flat surface or mount them on a wall. To mount them on a wall, install a screw or nail for each speaker at the position you want, then hang the speakers on the screw/nail.



## Using your speakers

This system lets you access two different sound sources: Optical or AUX.

### Listening to your speakers

- 1 Press the  (Power) button on the transmitter or the remote control to turn on your speaker system. The power indicator on the transmitter turns off.
- 2 Turn on the audio source device connected to your speakers and begin playback.
- 3 Press the  (source) button on the transmitter to select the audio source or press the selected source button on the remote control until you hear sound from your speakers.

#### Note

When you use the OPTICAL connection, the audio content should be PCM or Dolby 5.1. Refer to the manual you received with the output device for additional information.

- 4 Adjust the volume on the transmitter, or with the remote control, or on the audio source device to a comfortable level.

#### Warning

Continuous use of high volume sound may permanently damage your hearing.

- 5 Press the  (Power) button again to turn off your speaker system. The power indicator on the transmitter lights red.



# Maintaining your speakers

## Replacing the remote control battery

- 1 Squeeze the battery tray's sides together and slide it out of the remote control.
- 2 Remove the old battery and insert the new 3V lithium battery (CR2025) into the battery tray. Match the polarity of the new battery with the plus sign (+) in the battery tray.
- 3 Slide the battery tray back into the battery compartment until it clicks into place.

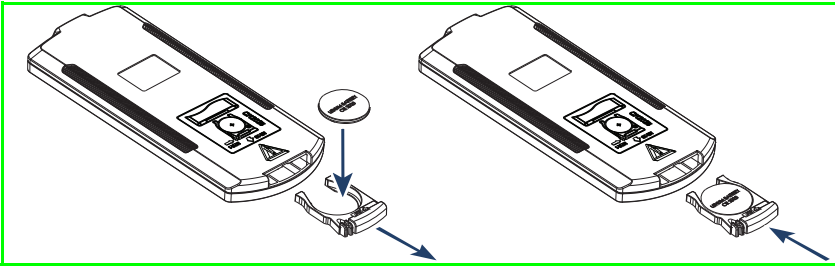

### Cautions



- The battery should not be exposed to excessive heat, such as sunshine, heat registers, or fire.
- Battery chemicals can cause a rash. If the battery leaks, clean the battery compartment with a cloth. If chemicals touch your skin, wash immediately.
- Make sure that the battery is disposed of correctly. Do not burn or incinerate.

### Notes

- Remove the battery when the charge is depleted.
- If the remote control is not going to be used for a long time, remove the battery to avoid any damage that may be caused by leakage and corrosion.

## Troubleshooting

Check this list for a possible troubleshooting solution before calling for service.

PROBLEM	POSSIBLE SOLUTIONS
The power does not come on.	<ul style="list-style-type: none"> <li>• Make sure that the AC adapter is securely plugged into the power outlet and the affected transmitter or receiver.</li> </ul>
The remote control does not work.	<ul style="list-style-type: none"> <li>• Remove any obstacles between the remote control and the IR sensor on the speakers.</li> <li>• The remote control battery may be exhausted, replace it.</li> <li>• Move closer to the speakers. The remote control is only effective to approximately 23 ft. (7 m).</li> </ul>
There is no sound or very low-level sound is heard from the speakers.	<ul style="list-style-type: none"> <li>• Make sure that you are connected to an audio OUT jack on your sound source. The port will not send audio out if it is an INPUT.</li> <li>• Make sure that the volume level of the speakers is set to an adequate level.</li> <li>• Make sure that the volume level is not muted. Press the  (mute) button on the remote control again to restore the sound output.</li> <li>• Make sure that the correct audio source is selected. Press the  button on the transmitter or the source button on the remote control to switch to the correct audio source.</li> <li>• Make sure that the power is on and all connections are secure.</li> <li>• Make sure that the volume is turned up on your sound source.</li> <li>• If you are using the OPTICAL connection, make sure that the source device's audio source is set to "PCM" format. Refer to the documentation your received with the audio source device (such as a TV or DVD/Blu-ray player, etc.) for additional information.</li> <li>• Make sure that the audio cable you are using is not damaged or broken. Try using another one.</li> </ul>
Your speakers are not working properly.	<ul style="list-style-type: none"> <li>• Unplug the AC adapters from the wall outlet and then try plugging them in again after 30 seconds.</li> <li>• If you are using the OPTICAL connection, make sure that the source device's audio source is set to "PCM" format. Refer to the documentation your received with the audio source device (such as a TV, DVD/Blu-ray player, etc.) for additional information.</li> <li>• Make sure that the audio cable you are using is not damaged or broken. Try using another one.</li> </ul>
The sound is breaking up or buzzing.	<ul style="list-style-type: none"> <li>• Make sure that you are connected to an audio OUT jack on your sound source. The port will not send audio out if it is an INPUT.</li> <li>• Make sure that all connections are secure and cables are not broken or damaged.</li> <li>• If you are using the OPTICAL connection, make sure that the source device's audio source is set to "PCM" format. Refer to the documentation your received with the audio source device (such as a TV or DVD/Blu-ray player, etc.) for additional information.</li> <li>• Connect to a different source device (such as a TV or DVD/Blu-ray player) to see if the buzzing still occurs. If it does not, this may indicate an issue with the original source device.</li> <li>• Use a different connection method (for example, try Optical instead of AUX) between the transmitter and the source device to make sure that the jacks on both devices are still working.</li> <li>• Make sure that the audio cable you are using is not damaged or broken. Try using another one.</li> </ul>
I can hear sound from both my TV and my speakers.	<ul style="list-style-type: none"> <li>• Turn off or mute the internal speakers of your TV. Refer to the TV's manual for instructions.</li> </ul>

PROBLEM	POSSIBLE SOLUTIONS
My TV remote does not control my speakers.	<ul style="list-style-type: none"> <li>• If you are using a universal remote control, make sure that it is programmed to your speakers. See Programming a universal remote on page 10.</li> <li>• Universal remotes will only control your speakers' volume. Use the controls on your speakers or the remote that came with it to change the speakers' audio source or sound mode.</li> <li>• Make sure that you aim your universal remote at the remote sensor on the front of your speakers.</li> <li>• Make sure that you select the correct source on your universal remote.</li> </ul>
My s keep unpairing.	<ul style="list-style-type: none"> <li>• Shorten the distance between the s.</li> </ul>

## Specifications

Designs and specifications are subject to change without notice.

Power output	Left and right channel
Frequency response	20Hz-20 KHz
Dimensions (approx.) (H x W x D)	Transmitter Module: 1.04 x 5.04 x 3.6 in. (26.5 x 128 x 91mm) Receiver Module: 1.04 x 5.04 x 3.7 in. (26.5 x 128 x 93.4 mm) Surround speaker Module: 3.6 x 3.5 x 4.15 in.(92 x 90 x 105.5 mm)
Weight	Transmitter: 5.3 oz. (0.15 kg) Receiver: 5.6 oz. (0.16 kg)
Battery	3V lithium battery (CR2025)
Inputs	AUX (3.5 mm stereo audio) jack Digital optical audio jack

## Legal notices

### FCC Part 15

This device complies with Part 15 of the FCC Rules. Operation of this product is subject to the following two conditions: (1) this device may not cause harmful interference, and (2) this device must accept any interference received, including interference that may cause undesired operation.

This equipment has been tested and found to comply within the limits for a class B digital device, pursuant to Part 15 of the FCC Rules. These limits are designed to provide reasonable protection against harmful interference in a residential installation. This equipment generates, uses, and can radiate radio frequency energy and, if not installed and used in accordance with the instructions, may cause harmful interference to radio communications. However, there is no guarantee that interference will not occur in a particular installation. If this equipment does cause harmful interference to radio or television reception, which can be determined by turning the equipment off and on, the user is encouraged to try to correct the interference by one or more of the following measures:

- Reorient or relocate the receiving antenna.
- Increase the separation between the equipment and receiver.
- Connect the equipment into an outlet on a circuit different from that to which the receiver is connected.

- Consult the dealer or an experienced technician for help.

### **FCC warning**

Changes or modifications not expressly approved by the party responsible for compliance with the FCC Rules could void the user's authority to operate this equipment.

### **Canada IC statement**

This device complies with Industry license-exempt RSS standard(s). Operation is subject to the following two conditions: (1) this device may not cause interference, and (2) this device must accept any interference, including interference that may cause undesired operation of the device.

Ce dispositif est conforme à la norme de l'industrie RSS exempts de licence (s). Son fonctionnement est soumis aux deux conditions suivantes: (1) cet appareil ne peut pas provoquer d'interférences et (2) cet appareil doit accepter toute interférence, y compris les interférences qui peuvent causer un mauvais fonctionnement du dispositif."

This equipment complies with IC radiation exposure limits set forth for an uncontrolled environment.

Cet équipement est conforme à l'exposition aux rayonnements IC limites établies pour un environnement non contrôlé.

# ONE-YEAR LIMITED WARRANTY

## Definitions:

The Distributor\* of Insignia branded products warrants to you, the original purchaser of this new Insignia-branded product ("Product"), that the Product shall be free of defects in the original manufacturer of the material or workmanship for a period of one (1) year from the date of your purchase of the Product ("Warranty Period").

For this warranty to apply, your Product must be purchased in the United States or Canada from a Best Buy branded retail store or online at [www.bestbuy.com](http://www.bestbuy.com) or [www.bestbuy.ca](http://www.bestbuy.ca), and is packaged with this warranty statement.

## How long does the coverage last?

The Warranty Period lasts for 1 year (365 days) from the date you purchased the Product. Your purchase date is printed on the receipt you received with the Product.

## What does this warranty cover?

During the Warranty Period, if the original manufacture of the material or workmanship of the Product is determined to be defective by an authorized Insignia repair center or store personnel, Insignia will (at its sole option): (1) repair the Product with new or rebuilt parts; or (2) replace the Product at no charge with new or rebuilt comparable products or parts. Products and parts replaced under this warranty become the property of Insignia and are not returned to you. If service of Products or parts are required after the Warranty Period expires, you must pay all labor and parts charges. This warranty lasts as long as you own your Insignia Product during the Warranty Period. Warranty coverage terminates if you sell or otherwise transfer the Product.

## How to obtain warranty service?

If you purchased the Product at a Best Buy retail store location, please take your original receipt and the Product to any Best Buy store. Make sure that you place the Product in its original packaging or packaging that provides the same amount of protection as the original packaging. If you purchased the Product from a Best Buy online web site ([www.bestbuy.com](http://www.bestbuy.com) or [www.bestbuy.ca](http://www.bestbuy.ca)), mail your original receipt and the Product to the address listed on the web site. Make sure that you put the Product in its original packaging or packaging that provides the same amount of protection as the original packaging.

To obtain warranty service, in the United States call 1-888-BESTBUY, Canada call 1-866-BESTBUY. Call agents may diagnose and correct the issue over the phone.

## Where is the warranty valid?

This warranty is valid only in the United States and Canada at Best Buy branded retail stores or websites to the original purchaser of the product in the county where the original purchase was made.

## What does the warranty not cover?

This warranty does not cover:

- Customer instruction/education
- Installation
- Set up adjustments
- Cosmetic damage
- Damage due to weather, lightning, and other acts of God, such as power surges
- Accidental damage
- Misuse
- Abuse
- Negligence

- Commercial purposes/use, including but not limited to use in a place of business or in communal areas of a multiple dwelling condominium or apartment complex, or otherwise used in a place of other than a private home.
- Modification of any part of the Product, including the antenna
- Display panel damaged by static (non-moving) images applied for lengthy periods (burn-in).
- Damage due to incorrect operation or maintenance
- Connection to an incorrect voltage or power supply
- Attempted repair by any person not authorized by Insignia to service the Product
- Products sold "as is" or "with all faults"
- Consumables, including but not limited to batteries (i.e. AA, AAA, C etc.)
- Products where the factory applied serial number has been altered or removed
- Loss or Theft of this product or any part of the product
- Display panels containing up to three (3) pixel failures (dots that are dark or incorrectly illuminated) grouped in an area smaller than one tenth (1/10) of the display size or up to five (5) pixel failures throughout the display. (Pixel based displays may contain a limited number of pixels that may not function normally.)
- Failures or Damage caused by any contact including but not limited to liquids, gels or pastes.

REPAIR REPLACEMENT AS PROVIDED UNDER THIS WARRANTY IS YOUR EXCLUSIVE REMEDY FOR BREACH OF WARRANTY. INSIGNIA SHALL NOT BE LIABLE FOR ANY INCIDENTAL OR CONSEQUENTIAL DAMAGES FOR THE BREACH OF ANY EXPRESS OR IMPLIED WARRANTY ON THIS PRODUCT, INCLUDING, BUT NOT LIMITED TO, LOST DATA, LOSS OF USE OF YOUR PRODUCT, LOST BUSINESS OR LOST PROFITS. INSIGNIA PRODUCTS MAKES NO OTHER EXPRESS WARRANTIES WITH RESPECT TO THE PRODUCT, ALL EXPRESS AND IMPLIED WARRANTIES FOR THE PRODUCT, INCLUDING, BUT NOT LIMITED TO, ANY IMPLIED WARRANTIES OF AND CONDITIONS OF MERCHANTABILITY AND FITNESS FOR A PARTICULAR PURPOSE, ARE LIMITED IN DURATION TO THE WARRANTY PERIOD SET FORTH ABOVE AND NO WARRANTIES, WHETHER EXPRESS OR IMPLIED, WILL APPLY AFTER THE WARRANTY PERIOD. SOME STATES, PROVINCES AND JURISDICTIONS DO NOT ALLOW LIMITATIONS ON HOW LONG AN IMPLIED WARRANTY LASTS, SO THE ABOVE LIMITATION MAY NOT APPLY TO YOU. THIS WARRANTY GIVES YOU SPECIFIC LEGAL RIGHTS, AND YOU MAY ALSO HAVE OTHER RIGHTS, WHICH VARY FROM STATE TO STATE OR PROVINCE TO PROVINCE.

Contact Insignia:

For customer service please call 1-877-467-4289

[www.insigniaproducts.com](http://www.insigniaproducts.com)

INSIGNIA is a trademark of Best Buy and its affiliated companies.

Distributed by Best Buy Purchasing, LLC

7601 Penn Ave South, Richfield, MN 55423 U.S.A.

©2017 Best Buy. All rights reserved.

**Made in China**

# INSIGNIA™

[www.insigniaproducts.com](http://www.insigniaproducts.com)  
1-877-467-4289 (U.S. and Canada) or 01-800-926-3000 (Mexico)

INSIGNIA is a trademark of Best Buy and its affiliated companies.

Distributed by Best Buy Purchasing, LLC  
7601 Penn Ave South, Richfield, MN 55423 U.S.A.

©2017 Best Buy. All rights reserved.

**Made in China.**

V1 ENGLISH  
17-0287