

# chicco®

Rev. 00/04 040904



**Cod. 68451**

Artsana S.p.A. - Via Saldarini Catelli, 1  
Grandate Como - Italy - Made in China



OFFROAD R/C

RAIMONDO GIRAMONDO

MATTI MAAILMANMATKAAJA

RAIMONDO OBIEŻYŚWIA

RAIMONDO JORDENRUNTFARARE

ВЕЗДЕХОД РАЙМОНДО

www.chicco.com

# chicco®

2+



RAIMONDO GIRAMONDO

RADIO CONTROL TODOTERRENO

PATle4x4

RAIMONDO GIRAMONDO

RAIMONDO, DER GLOBETROTTER

OTTO DE GLOBETROTTER

OFFROAD R/C

VAGABONDEN RAIMONDO

fig. A.

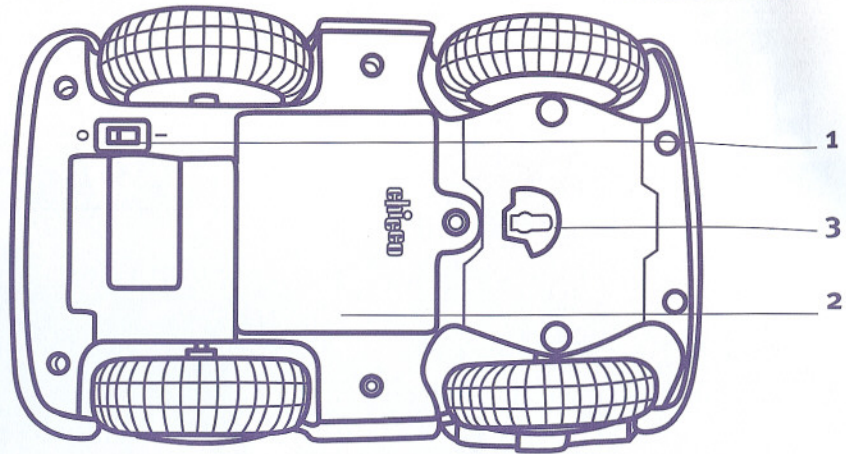

fig. B.

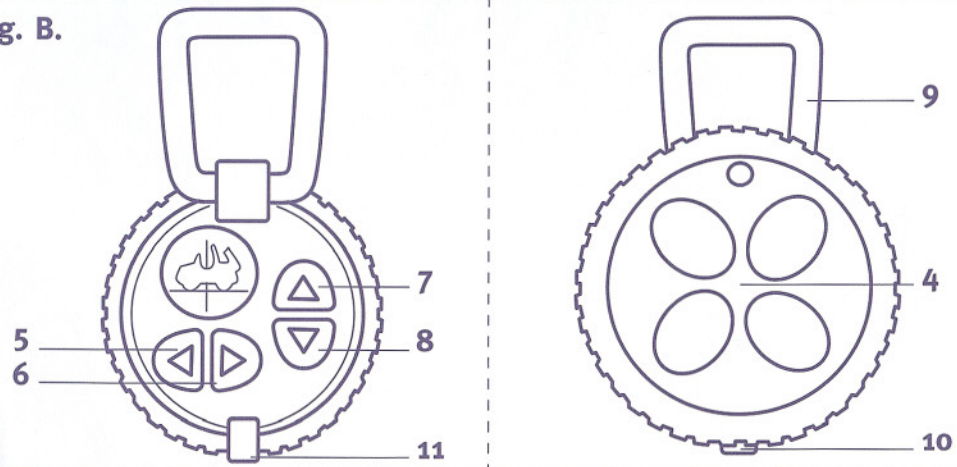

fig. C.

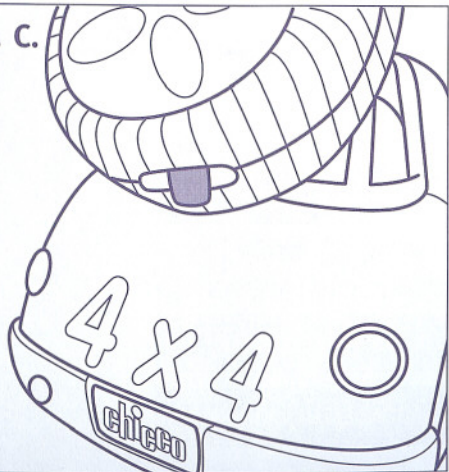
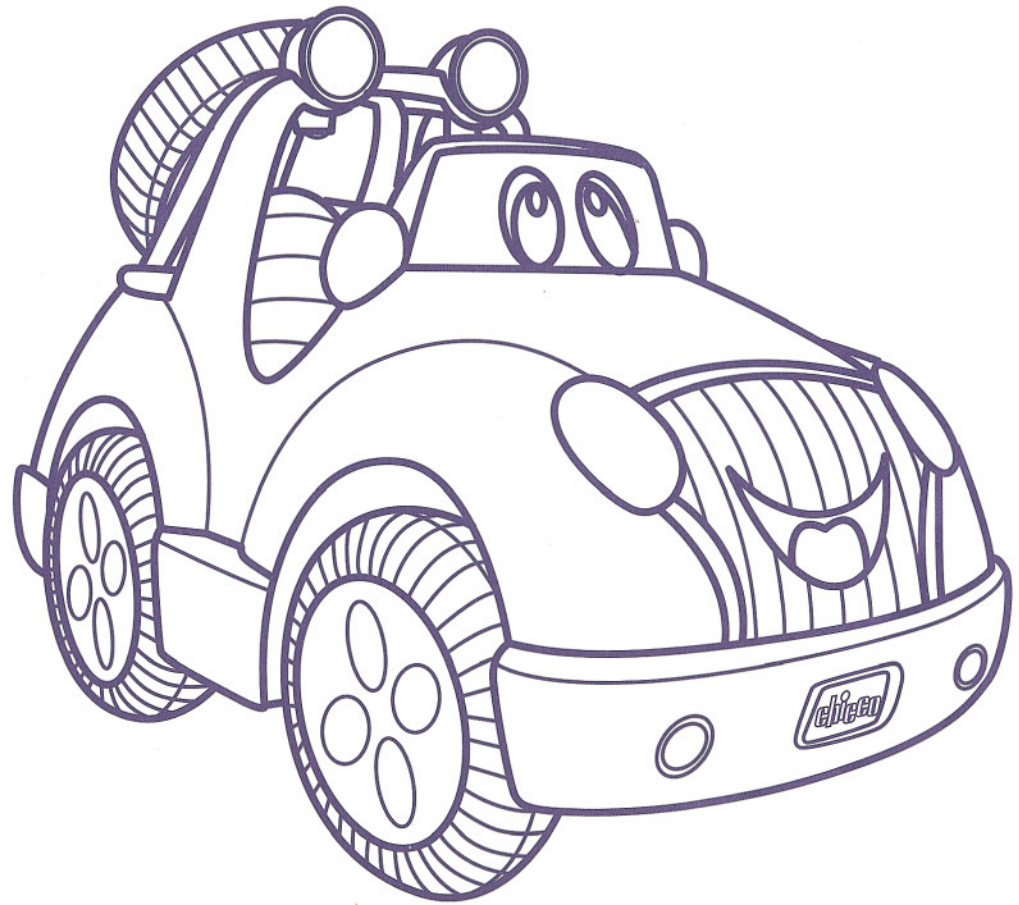
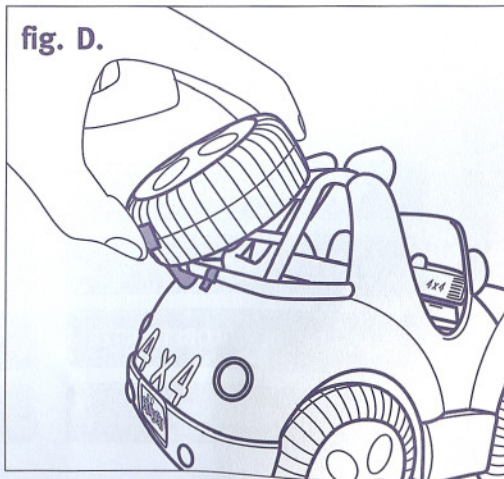

fig. D.



## Age: From 24 Months +

Please read these instructions carefully and keep for future reference.

- The toy is powered by 4 x 1.5 Volt "AA" type alkaline batteries and the remote control unit requires 3 x 1.5 Volt "AAA" type alkaline batteries (Batteries are not included).

For your child's safety:

### WARNING!

Before use remove and dispose of any plastic bags and any other packaging (e.g. fasteners and fixing ties etc) and keep them out of reach of children.

### WARNINGS

- It is recommended that you check the toy for signs of damage before use. Should any part be damaged, do not use and keep out of reach of children.
- **WARNING!**
  - Do not touch the toy's wheels while they are moving.
  - Do not use the toy on the road.
  - Do not use the toy on wet, sandy or dusty surfaces.
  - Do not leave the toy or the remote control unit next to heat sources.
- The toy's operation may be altered by radio interferences caused by: simultaneous use of two or more remote controlled toy cars on the same radio frequency; high voltage cables; high voltage transformers; certain kinds of buildings or walls; electromagnetic pollution; radio signals emitted by other devices.

The maximum operating range of the remote control unit is about 7 metres (this distance could be further reduced, according to environmental conditions).

### TECHNICAL CHARACTERISTICS

Transmitter's current absorption = 30mA

Receiver's current absorption = 1.100mA

### Jeep R/C

#### Fig. A

- 1) ON/OFF switch (I / O)
- 2) Battery compartment cover
- 3) Direction selector (wheel alignment)

### Remote control unit:

#### Fig. B

- 4) Battery compartment cover
- 5) Forward left button
- 6) Forward right button
- 7) Forward straight button
- 8) Reverse straight button
- 9) Aerial – handle
- 10) Remote control unit release button
- 11) Fastening prong

## TOY DESCRIPTION

Offroad R/C is a radio remote controlled electric toy car that moves in 4 directions (forward straight, backward straight, forward left and forward right).

Thanks to its simple controls, the toy is suitable for children from 2 years of age. At this age, a child can begin to use the remote control unit, by simply pressing the buttons and observing in which direction, the car moves. This exercise is very important, since it allows the child to extend its field of vision and hone its hand-eye co-ordination.

By the age of three, the child learns to associate the direction of movement, selected on the remote control unit, with the effect achieved by the car's movement. At first, the child will drive the car until it meets with an obstacle; later on the child will learn how to operate the remote control unit more precisely, in order to drive the car along a route of its choice.

For its operation, this product requires (as foreseen by the law in force) the use of public frequencies. For this reason, your toy car might receive signals from similar devices situated nearby; in such an event, the car might not move as selected.

## HOW TO USE THE TOY

1. Switch on the car, by moving the ON/OFF switch, located underneath the car, (fig. A-1) to position I.
2. To operate the toy, press the buttons on the remote control unit. The remote control unit features four buttons, corresponding to the directions forward left (fig. B-5), forward right (fig. B-6), forward straight (fig. B-7), backward straight (fig. B-8).
3. When you wish to stop playing, it is recommended that you always switch off the toy, by moving the ON/OFF switch (fig. A-1) to position O.

## How to attach the remote control unit to the vehicle

- When the car is switched off, the remote control unit can be attached to the car. To fasten the remote control unit to the car, position it as indicated in figure D, ensuring that the prong (fig. B-11) is inserted inside the rear section of the car, pressing downwards until it is fastened securely.
- To unfasten the remote control unit, press the release button and lift (fig. B-10).

## Direction selector control

If, when pressing the forward straight button (fig. B-7), the car does not move in a straight direction, it is possible to adjust the direction by moving the direction selector, located underneath the car, a notch at a time (fig. A-3).

## FITTING AND/OR REPLACING BATTERIES

- Batteries must only be fitted by an adult.
- To replace spent batteries: Loosen the screw on the battery compartment cover (fig. A-2 for the car and fig. B-4 for the remote control unit) with a screwdriver and remove the cover. Then remove the spent batteries and fit new ones, ensuring that they have been fitted in the correct polarity (as shown on the product), close the battery cover, and tighten the screw.
- Only use alkaline batteries of the same type or equivalent to the type recommended for the correct function of this product.
- Never mix new and old or different types of batteries.
- Always keep batteries and tools out of reach of children.
- Do not short-circuit the battery terminals.

- Always remove spent batteries from the toy to avoid the danger of leakage from the battery damaging the product.
- Always remove the batteries if the toy will not be used for a long period of time.
- Remove the batteries from the toy and the remote control unit prior to their disposal.
- Do not burn or dispose of into the environment spent batteries. Dispose of them at an appropriate differentiated collection point.
- If you detect any leakage from the batteries, replace them immediately, taking care to clean the battery compartment first. Wash your hands carefully if you have accidentally come in touch with the leaked liquid.
- Do not attempt to recharge non-rechargeable batteries they might explode.
- The use of rechargeable batteries is not recommended, since they might impair the toy's functionality.
- If rechargeable batteries are used, remove them from the toy before recharging. This operation should only be carried out under adult supervision.
- This toy has not been designed to operate with Lithium batteries. WARNING. Improper use could be dangerous.

## Declaration of Conformity to EC Regulations

**Artsana S.p.A. hereby declares that this remote control toy MOD. 3T - 3-R conforms to the essential requirements and to further regulations laid down in the 88/378 and 1999/5/EC directives.**

**In conformity with the decision of the European Committee No. 2000/299/EC of 06/04/2000, the frequency band used by this toy is the harmonized band used in all EU Countries. This is therefore a class 1 product, which can be used in all European Community Countries.**

Use of the product in countries not belonging to the European Community or in non-European countries is subject to the verification by the user regarding the equipment's conformity to the regulations in force in the users country.

## CARE & MAINTENANCE

- Clean the toy with a soft cloth, soaked in a little water, if necessary. Do not submerge the toy in water.
- Protect the toy from shocks, heat, dust, sand, humidity and water.

ARTSANA reserves the right to modify in any given moment and without advance notice the contents of this instruction booklet.

The reproduction, transmission, transcription as well as the translation into another language of all or part of this booklet, in any form, are absolutely prohibited, unless previously authorised in writing by ARTSANA

## 68451 Offroad R/C

This device complies with part 15 of the FCC Rules.

Operation is subject to the following two conditions:

- 1) this device may not cause harmful interference, and
- 2) this device must accept any interference received, including interference that may cause undesired operation.

### Caution:

Changes or modifications not expressly approved by the party responsible for compliance could void the user's authority to operate the equipment.

### NOTES:

This product has been tested and found to comply with the limits for a Class B digital device, pursuant to Part 15 of the FCC Rules. These limits are designed to provide reasonable protection against harmful interference in a residential installation.

This product generates, uses and can radiate radio frequency energy. If not installed and used in accordance with the instructions, may cause harmful interference to radio communications. However, there is no guarantee that interference will not occur in a particular installation. If this product does cause harmful interference to radio or television reception, which can be determined by turning the equipment off and on, Please try to correct the interference by one of the following measures:

- a) Reorient or relocate the receiving antenna;
- b) Increase the separation between the equipment and receiver;
- c) Connect the equipment into an outlet on a circuit different from that to which the receiver is connected;
- d) Consult the dealer or an experienced radio / TV technician for help.