

## Embedded Wireless LAN Controller Module

### DESCRIPTION

The WB4343W and W43364 Wi-Fi®/Bluetooth®/Bluetooth Smart Mini Modules are complete standalone solutions for designers looking to take advantage of the high data rate of Wi-Fi, to interface to legacy Bluetooth Classic devices already in the field, and to utilize the low power consumption and mesh network capabilities of Bluetooth Smart. They eliminate design risk and significantly reduce time-to-market for a multitude of M2M applications.

These devices are footprint-compatible with CEL's existing line of ZigBee®, Thread, and Bluetooth®-based modules, allowing solutions which easily transition between multiple wireless networking standards via drop-in compatible module hardware.

The WB4343W and W43364 Mini Module family consists of four drop-in compatible devices so the feature set can be optimized for your application. Options include Wi-Fi/Bluetooth/Bluetooth Smart (WB4343W) or Wi-Fi only (W43364) radios, plus different MCU memory sizes (STM32F411 MCU with 512kB flash/128kB RAM or STM32F412 MCU with 1MB flash/256kB RAM).

Based on the Broadcom BCM4343W and BCM43364 transceivers and the ST Micro STM32 microprocessor, the Cortet Mini Modules combine the BCM43xxx's 32-bit ARM® Cortex®-M3 MCU, integrated ROM & RAM, 2.4 GHz radio, LNA, PA, and internal transmit/receive RF switch with an ultra low power, high performance 32-bit ARM® Cortex®-M4F MCU with FPU, 512KB or 1MB flash, 128kB or 256kB SRAM, and all necessary crystals and filtering.

These devices leverage the world-class WICED™ SDK toolset from Broadcom, and are capable of running the WICED stack plus the product application code without requiring an additional microprocessor. They are optimized for small size and low power consumption, and can be run directly from a rechargeable mobile platform battery. They include Broadcom's Enhanced Collaborative Coexistence algorithms and hardware mechanisms, allowing for an extremely collaborative Wi-Fi and Bluetooth coexistence.

### KEY FEATURES

- Wi-Fi (802.11 b/g/n, single stream)
- Bluetooth 2.1+EDR & 3.0, Bluetooth 4.1 (BLE)
- Fully Compatible with the Broadcom WICED SDK
- Dual MCUs (32-bit ARM® Cortex®-M3 & -M4F)
- 512 kB or 1MB Flash, 128kB or 256kB SRAM
- Up to 25 GPIOs, including SPI, USART, I2C, ADCs and timers
- Internal antenna or RF port for external antenna
- Mini footprint: 0.940" x 0.655" (23.9 x 16.6mm)
- Footprint-compatible with CEL's Bluetooth, ZigBee, and Thread module family
- FCC, IC, Wi-Fi Alliance, and Bluetooth SIG certified

### APPLICATIONS

- Connected Home & Appliances
- Building Control & Automation
- Lighting
- Security
- Wireless Sensor Networks
- Wireless Audio & Video
- Remote Health and Wellness Monitoring
- General M2M Wireless Networking



**TABLE OF CONTENTS**

DESCRIPTION .....	1
KEY FEATURES.....	1
APPLICATIONS.....	1
TABLE OF CONTENTS .....	2
DEVELOPMENT TOOLS.....	3
BLOCK DIAGRAM.....	3
ORDERING INFORMATION.....	4
ANTENNA.....	4
TRANSCEIVER IC .....	5
MICROPROCESSOR.....	5
SOFTWARE/FIRMWARE.....	5
ABSOLUTE MAXIMUM RATINGS .....	6
RECOMMENDED OPERATING CONDITIONS.....	6
DC CHARACTERISTICS .....	7
RF CHARACTERISTICS.....	7
I/O PIN ASSIGNMENTS .....	11
CEL MINI MODULE COMPATIBILITY.....	12
MODULE DIMENSIONS .....	12
MODULE LAND FOOTPRINT .....	13
PROCESSING .....	14
AGENCY CERTIFICATIONS .....	16
SHIPMENT, HANDLING AND STORAGE.....	17
QUALITY .....	17
REVISION HISTORY .....	18
DISCLAIMER .....	18

## DEVELOPMENT TOOLS

### Cortet Radio WICED Evaluation Kit for Wi-Fi and Bluetooth

The Cortet Radio WICED Evaluation Kit is designed for rapid evaluation of the WB43xxxSP2 family. Based on the best-in-class Broadcom WICED software development environment, the WB43xxx Evaluation Kit is a comprehensive solution for software prototyping and making hardware measurements.

Kit contents:

- Evaluation board with push buttons, LEDs, analog inputs, JTAG over USB interface for software programming and debug, external voltage inputs, ammeter interface, and GPIO breakout pins
- Daughtercard with WB4343WF3SP2-1C module (Wi-Fi/Bluetooth transceiver + STM32F411 MCU, including 512kB flash and 128kB RAM)
- Programming interface cable
- Link to online documentation

Visit [cortet.cel.com/wb4343](http://cortet.cel.com/wb4343) for more information.

The Cortet Radio WICED Evaluation Kit utilizes a modular daughtercard architecture. Once the base kit (WB43XXX-EVK-1) has been purchased, WB43xxxSP2 daughtercards containing a header compatible with the WB43xxx Evaluation Kit can be ordered separately for all members of the WB43xxxSP2 module family. See ordering information below for more details.



WB43xxx Evaluation Kit



Add-on daughtercard for use with WB43xxx Evaluation Kit

## BLOCK DIAGRAM

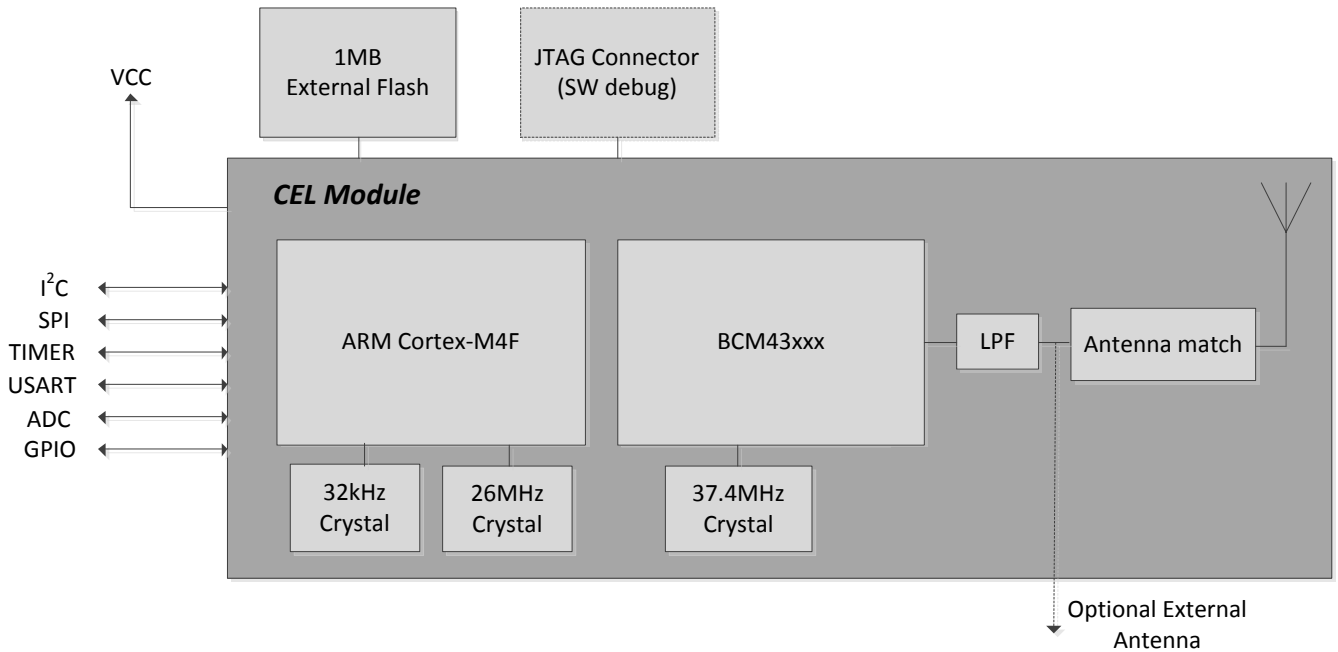

**ORDERING INFORMATION**

Order Number	Description	Min/Multiple
WB4343WF3SP2-1-R	Wi-Fi/BT Module, BCM4343W Transceiver + STM32F411 MCU (512kB flash, 128kB RAM), Trace Antenna	600
WB4343WF3SP2-1C-R	Wi-Fi/BT Module, BCM4343W Transceiver + STM32F411 MCU (512kB flash, 128kB RAM), Castellation Pin for External Antenna	600
WB4343WF4SP2-1-R	Wi-Fi/BT Module, BCM4343W Transceiver + STM32F412 MCU (1MB flash, 256kB RAM), Trace Antenna	600
WB4343WF4SP2-1C-R	Wi-Fi/BT Module, BCM4343W Transceiver + STM32F412 MCU (1MB flash, 256kB RAM), Castellation Pin for External Antenna	600
W43364F3SP2-1-R	Wi-Fi Module, BCM43364 Transceiver + STM32F411 MCU (512kB flash, 128KB RAM), Trace Antenna	600
W43364F3SP2-1C-R	Wi-Fi Module, BCM43364 Transceiver + STM32F411 MCU (512kB flash, 128KB RAM), Castellation Pin for External Antenna	600
W43364F4SP2-1-R	Wi-Fi Module, BCM43364 Transceiver + STM32F412 MCU (1MB flash, 256KB RAM), Trace Antenna	600
W43364F4SP2-1C-R	Wi-Fi Module, BCM43364 Transceiver + STM32F412 MCU (1MB flash, 256KB RAM), Castellation Pin for External Antenna	600
WB43XXX-EVK-1	WB43xxx Evaluation Kit - Universal Eval Board + WB43xxx Programming Fixture, pre-populated with WB4343F3SP2-1C-EVB on daughtercard	1
WB4343WF3SP2-1-EVB	WB4343WF3SP2-1 on daughtercard for use with WB43xxx-EVK-1	1
WB4343WF3SP2-1C-EVB	WB4343WF3SP2-1C on daughtercard for use with WB43xxx-EVK-1	1
WB4343WF4SP2-1-EVB	WB4343WF4SP2-1 on daughtercard for use with WB43xxx-EVK-1	1
WB4343WF4SP2-1C-EVB	WB4343WF4SP2-1C on daughtercard for use with WB43xxx-EVK-1	1
W43364F3SP2-1-EVB	W43364F3SP2-1 on daughtercard for use with WB43xxx-EVK-1	1
W43364F3SP2-1C-EVB	W43364F3SP2-1C on daughtercard for use with WB43xxx-EVK-1	1
W43364F4SP2-1-EVB	W43364F4SP2-1 on daughtercard for use with WB43xxx-EVK-1	1
W43364F4SP2-1C-EVB	W43364F4SP2-1C on daughtercard for use with WB43xxx-EVK-1	1

**ANTENNA**

The Cortet Mini Modules include an integrated Printed Circuit Board (PCB) trace antenna. An optional configuration which uses a castellation pin on the module allows the user to connect to an external antenna. The WB43xxxSP2 family has been certified with the PCB trace antenna only. The PCB antenna employs a topology that is compact and highly efficient. To maximize range, an adequate ground plane must be provided on the host PCB. Correctly positioned, the ground plane on the host PCB will contribute significantly to the antenna performance.

For optimum antenna performance, the Cortet Mini Module should be mounted with the PCB trace antenna overhanging the edge of the host board. To further improve performance, a ground plane may be placed on the host board under the module, up to the antenna but not extending under the antenna (a minimum of 1.5" x 1.5" is recommended). The installation of an uninterrupted ground plane on a layer directly beneath the module will also allow traces to be routed under the layer. Refer to the application note *Mini Modules Hardware Design Guidelines* for more details. CEL can assist with your PCB layout.

The following are some design guidelines to help ensure optimal antenna performance:

- The antenna portion of the Mini Module should hang over the host board so that there is not any additional PCB under the antenna.
- Never place the antenna close to metallic objects
- In the final assembly, ensure that wiring and other components are not placed near the antenna
- Do not place the antenna in a metallic or metalized plastic enclosure
- Keep plastic enclosures a minimum of 1cm away from the antenna in any direction

Under Industry Canada regulations, this radio transmitter may only operate using an antenna of a type and maximum (or lesser) gain approved for the transmitter by Industry Canada. To reduce potential radio interference to other users, the antenna type and its gain should be so chosen that the equivalent isotropically radiated power (e.i.r.p.) is not more than that necessary for successful communication.

Conformément à la réglementation d'Industrie Canada, le présent émetteur radio peut fonctionner avec une antenne d'un type et d'un gain maximal (ou inférieur) approuvé pour l'émetteur par Industrie Canada. Dans le but de réduire les risques de brouillage radioélectrique à l'intention des autres utilisateurs, il faut choisir le type d'antenne et son gain de sorte que la puissance isotrope rayonnée équivalente (p.i.r.e.) ne dépasse pas l'intensité nécessaire à l'établissement d'une communication satisfaisante.

## TRANSCEIVER IC

The WB43xxxSP2 family utilizes the BCM4343W or BCM43364 transceiver (WB4343WFxSP2 or W43364FxSP2 models respectively), which is a highly integrated 2.4GHz WLAN IEEE 802.11 b/g/n MAC/baseband transceiver. It integrates a power amplifier (PA) and a low-noise amplifier (LNA) for best-in-class receiver sensitivity and an internal transmit/receive RF switch. The BCM4343W transceiver supports the Wi-Fi, Bluetooth, and Bluetooth Smart protocols, while the BCM43364 transceiver supports Wi-Fi only.

Both transceivers also contain an ARM® Cortex®-M3 32-bit RISC microprocessor, with 640kB ROM and 512kB RAM for running software from the Link Control Layer up to the Host Controller Interface.

## MICROPROCESSOR

The Cortet Mini Modules contain a STM32 microprocessor from ST Micro, which is a 32-bit ARM® Cortex®-M4F processor running at 100MHz. The WB43xxxF3 utilizes the STM32F411 with 512kB of flash and 128kB of SRAM, and the WB43xxxF4 utilizes the STM32F412 with 1MB of flash and 256kB of SRAM. Both MCUs support a rich set of peripherals, including SPI, USART, I2C, 12-bit ADCs and timers. This ARM® Cortex®-M4F core features a floating point unit (FPU) which supports all ARM® single-precision data-processing instructions and data types. It also implements a full set of DSP instructions and a memory protection unit (MPU) which enhances application security.

With the resources of the on-board STM32 microprocessor, the WB43xxxF3 and WB43xxxF4 Mini Modules are capable of running the full Broadcom WICED stack plus the product application code, providing a full standalone solution. The WB43xxxF4 is ideal for resource-intensive applications like a Wi-Fi/Bluetooth Smart Bridge with support for Amazon Web Services and Apple HomeKit, while the WB43xxxF3 is a more cost-effective solution for Wi-Fi enabled end devices.

## SOFTWARE/FIRMWARE

The Cortet Mini Modules utilize the WICED software development environment, which allows designers to quickly and easily integrate Wi-Fi and Bluetooth connectivity into any product. WICED is an open-source build system based on GNU 'make' and will also run on commercial toolchains such as IAR. It has a GUI development environment based on Eclipse CDT, and supports a JTAG programmer and single-step, thread-aware debugger based on OpenOCD and gdb. The WICED platform offers several RTOS/TCP stack options, has a simple API for accessing hardware peripherals, and includes advanced security and networking features like SSL/TLS and IPv4/IPv6 TCP/IP networking stacks. It is a production-ready application framework, including a bootloader, flash storage API, over-the-air upgrades, factory reset, and a system monitor.

**ABSOLUTE MAXIMUM RATINGS**

Description	Min	Max	Unit
Storage Temperature	-40	85	°C
Voltage Ripple (Max. value not to exceed operating voltage)		2	%
Power Supply Voltage		4	V

**RECOMMENDED OPERATING CONDITIONS**

Symbol	Parameter	Min	Typ	Max	Unit
	Frequency	2405		2484	MHz
	Power Supply Voltage	3.0	3.3	3.6	V
	Operating Temperature	-40		85	°C
	Humidity Range			95	%
					Non condensing

**DC CHARACTERISTICS**

(@ 25°C unless otherwise specified)

**WLAN**

Item	Condition	Min	Nom	Max	Unit
Tx mode (11b Max current)	11Mbps		300		mA
Tx mode (11g Max current)	54Mbps		275		mA
Tx mode (11n Max current)	MCS7		275		mA

Rx mode	11b (11Mbps)		45		mA
	11g (54Mbps)		45		mA
	11n (MCS7)		46		mA

**BLUETOOTH**

(WB4343W variants only)

Condition: +10dBm

Item	Condition	Min	Nom	Max	Unit
Tx Mode	3DH5		30		mA
RX Mode	3DH5		20		mA
BLE Scan	1.28 s. interval with 11.25 ms window		350		μA
BLE Adv. – Unconnectable 1 sec.			270		μA
BLE Connected 1 sec.			250		μA

**RF CHARACTERISTICS****Wi-Fi RF SPECIFICATION**

Features	Description
WLAN Standards	IEEE 802 Part 11 b/g/n (802.11b/g/n single stream)
Antenna Port	Support Single Antenna for Wi-Fi / Diversity with external switch
Frequency Band	2.4000 – 2.497 GHz (2.4 GHz ISM Band)
Number of selectable Sub CH	14 channels
Modulation	OFDM, DSSS (Direct Sequence Spread Spectrum), DBPSK, DQPSK, CCK , 16QAM, 64QAM, 256QAM
Supported rates	1, 2, 5.5, 11, 6, 9, 12, 24, 36, 48, 54 Mbps & HT20 MCS0~7

Item	Condition	Nom	Unit
Maximum RX Input Level	with PER < 8% @ 11 Mbps	-10	dBm
	with PER < 10% @ 54 Mbps	-20	dBm
	with PER < 10% @ MCS7	-20	dBm
Output Power	17dBm @ 802.11b	17	dBm
	13dBm @ 802.11g	13	dBm
	12dBm @ 802.11n	12	dBm
	@ 802.11n (256QAM)	10	dBm

The RF performance reported above assumes a default supply voltage of 3.3V.

## TRANSMITTER SPECIFICATION

802.11b Transmitter					
Item	Condition	Min.	Typ.	Max.	Unit
Transmit Output Power	1M/2M/5.5M/11M		17		dBm
Transmit spectrum mask	$F_c - 22\text{MHz} < F < F_c - 11\text{MHz}$ & $F_c + 11\text{MHz} < F < F_c + 22\text{MHz}$ (1/2/5.5/11Mbps; channel 1~13)			-30	dBc
	$F < F_c - 22\text{MHz}$ & $F > F_c + 22\text{MHz}$ (1/2/5.5/11Mbps; channel 1~13)			-50	dBc
Transmit power - on	10% ~ 90 %		0.3	2	μs
Transmit power - down	90% ~ 10 %		1.5	2	μs
Transmit modulation accuracy	1/2/5.5/11 Mbps		-17	-10	dB

802.11g Transmitter					
Item	Condition	Min.	Typ.	Max.	Unit
Transmit Output Power	6M/9M/12M/18M/24M/36M/48M/54M		13		dBm
Transmit spectrum mask	@ 11MHz			-20	dBc
	@ 20MHz			-28	dBc
	@ 30MHz			-40	dbc
Transmit modulation accuracy	6Mbps			-5	dB
	9Mbps			-8	dB
	12Mbps			-10	dB
	18Mbps			-13	dB
	24Mbps			-16	dB
	36Mbps			-19	dB
	48Mbps			-22	dB
54Mbps			-25	dB	

802.11n Transmitter					
Item	Condition	Min.	Typ.	Max.	Unit
Transmit Output Power	HT20 MCS 0~7		12		dBm
	HT20 MCS7		10		dBm
Transmit spectrum mask	@ 11MHz			-20	dBc
	@ 20MHz			-28	dBc
	@ 30MHz			-40	dbc
Transmit modulation accuracy	HT20 MCS 0~7			-27	dB
	HT20 MCS7			-32	dB



Bluetooth Transmitter (WB4343W variants only)					
Item	Condition	Min.	Typ.	Max.	Unit
Frequency Range		2402		2480	MHz
Channel Spacing			1		MHz
Transmit Output Power	GFSK		10		dBm
	QPSK		6		dBm
	BPSK		6		dBm
Initial Carrier Freq. Tolerance			25	75	kHz
Lock Time			72		μS
Frequency Drift	DH1 Packet		8	25	kHz
	DH3 Packet		8	40	kHz
	DH5 Packet		8	40	kHz
	Drift Rate		5	20	KHz/50μS
Frequency Deviation	00001111 sequence	140	155	175	kHz
	10101010 sequence	115	140		kHz

Bluetooth Low Energy Transmitter (WB4343W variants only)					
Item	Condition	Min.	Typ.	Max.	Unit
Frequency Range		2402		2480	MHz
Transmit Output Power			8		dBm
Mod Char: delta f1 average		225	225	275	kHz
Mod Char: delta f2 max		99.9			%
Mod Char: ratio		0.8	0.95		%

## RECEIVER SPECIFICATION

802.11b Receiver					
Item	Condition	Min.	Typ.	Max.	Unit
Minimum Input Level Sensitivity (PER < 8%)	1Mbps	-80	-93		dBm
	2Mbps	-80	-91		dBm
	5.5Mbps	-76	-89		dBm
	11Mbps	-76	-86		dBm
Maximum Input Level (PER < 8%)	1/2/5.5/11Mbps			-10	dBm

802.11g Receiver					
Item	Condition	Min.	Typ.	Max.	Unit
Minimum Input Level Sensitivity (PER < 10%)	6Mbps	-82	-88		dBm
	9Mbps	-81	-87		dBm
	12Mbps	-79	-85		dBm
	18Mbps	-77	-83		dBm
	24Mbps	-74	-80.5		dBm
	36Mbps	-70	-78.5		dBm
	48Mbps	-66	-74		dBm
	54Mbps	-65	-72		dBm
Maximum Input Level (PER < 10%)	6/9/12/18/24/36/48/54Mbps			-20	dBm

802.11n Receiver					
Item	Condition	Min.	Typ.	Max.	Unit
Minimum Input Level Sensitivity (PER < 10%)	HT20, MCS0	-82	-87.5		dBm
	HT20, MCS1	-79	-84		dBm
	HT20, MCS2	-77	-82		dBm
	HT20, MCS3	-74	-80.5		dBm
	HT20, MCS4	-70	-77		dBm
	HT20, MCS5	-66	-72		dBm
	HT20, MCS6	-65	-71		dBm
	HT20, MCS7	-64	-70		dBm
	256-QAM R 3/4		-68		dBm
	256-QAM R=5/6		-66		dBm
Maximum Input Level (PER < 10%)	MSC0~MSC7			-20	dBm

Bluetooth Receiver <i>(WB4343W variants only)</i>					
Item	Condition	Min.	Typ.	Max.	Unit
Minimum Input Level Sensitivity (PER < 10%)	GFSK, 0.1% BER, 1Mbps		-91		dBm
	$\pi/4$ -DQPSK, 0.01% BER, 2Mbps		-93		dBm
	8-DPSK, 0.01% BER, 3Mbps		-87		dBm
Input IP3		-16			dBm
Maximum Input Level				-20	dBm

Bluetooth Low Energy Receiver <i>(WB4343W variants only)</i>					
Item	Condition	Min.	Typ.	Max.	Unit
Minimum Input Level Sensitivity with Dirty Transmitter	GFSK, 0.1% BER, 1Mbps		-94		dBm

**I/O PIN ASSIGNMENTS**

Refer to the STM32 datasheet for pin functionality details.

Module Pin Number	STM32F41x UFBGA100 Pin Number	Pin Name	Notes
1, 2, 12, 31, 33	D3,F2,J1,F12, F11,	GND	
3	J2	PC1	
4	H2	Reset	
5	A4	BOOT0	
6	L6	PB2/BOOT1	
7	L2	PA0/WAKE	
8	B12	PA11/USART1_CTS	
9	A12	PA12/USART1_RTS	
10	M4	PA7/SPI1_MOSI	
11	L4	PA6/SPI1_MISO	
13	C4,E2,G2,M1, G12,G11	VDD	Input power to the module.
14	K4	PA5/SPI1_SCK	
15	M3	PA4/SPI1_NSS	
16	B5	PB6	
17	B4	PB7	
18	H1	PC0	
19	D10	PA9/USART1_TX	
20	C12	PA10/USART_RX	
21	A10	PA14/JTCK	
22	A8	PB3/JTDO	
23	A9	PA15/JTDI	
24	A11	PA13/JTMS	
25	J3	PC2	
26	K2	PC3/ADC1_13	Could be A/D or GPIO
27	A7	PB4/JRST	
28	L3	PA3/ADC1_3	Could be A/D or GPIO
29	K3	PA2/ADC1_2	Could be A/D or GPIO
30	M2	PA1/ADC1_1	Could be A/D or GPIO
32	-	RF OUT	Castellation Pin for External Antenna

**NOTE: I/O PINOUTS ARE PRELIMINARY AND SUBJECT TO CHANGE. CONTACT CEL BEFORE COMMITTING TO PCB LAYOUTS TO ENSURE THAT PINOUT MAPPING MATCHES CEL'S FINAL DESIGN.**

### CEL MINI MODULE COMPATIBILITY

The geometry of the land pattern and location of the RF castellations is identical to CEL's ZICM35x family of ZigBee/Thread and B1010 Bluetooth Smart Mini Modules. The digital and analog mapping to develop a drop-in compatible solution is described below:

Pin #	Function	ZICM35x	B1010	WB43xxx	Notes
4	Reset	RESET	N/C	RESET	
5, 6	Low frequency crystal	PC6, PC7	N/C	N/C	Low frequency crystal is internal for B1010 and WB43xxx
7	Wake	PA7	WAKE	PA0	
8, 9, 19, 20	Serial Controller 1	UART/SPI/I2C	Two wire UART/I2C	USART/I2C	
10, 11, 14, 15	Serial Controller 2	SPI/I2C	I2C	SPI/I2C	
16, 17, 21, 22, 23, 24, 27	Programming	Programming	Programming	Programming	
28, 30	ADC	PB7, PB5	AIO[1], AIO[2]	PA3, PA1	
29	Timer	PB6	PIO[11]	PA2	

### MODULE DIMENSIONS

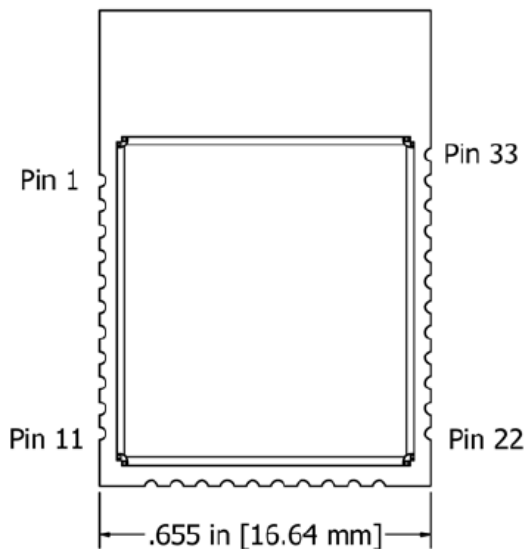

**TOP VIEW**

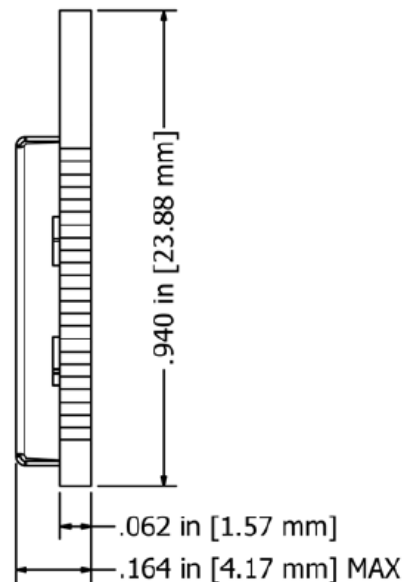

**SIDE VIEW**

**Note:** All dimensions are ± .005 in [0.12 mm] unless otherwise specified

**MODULE LAND FOOTPRINT**

Dimensions are shown in inches, with millimeter conversion in brackets

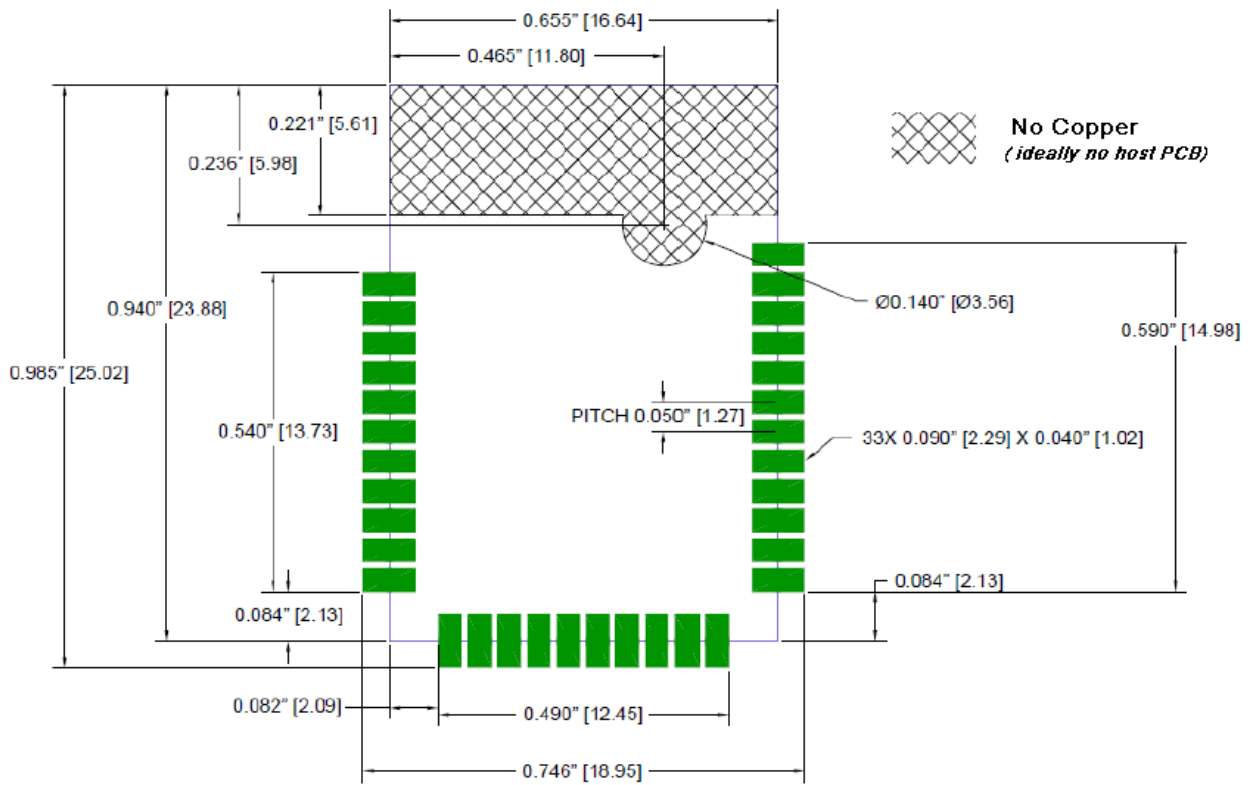

Note: Refer to the Antenna section in this document for layout recommendations which will yield optimal antenna performance.

## PROCESSING

### Recommended Reflow Profile

Parameter Values	
Ramp Up Rate (from $T_{\text{soakmax}}$ to $T_{\text{peak}}$ )	3%/sec max
Minimum Soak Temperature	150°C
Maximum Soak Temperature	200°C
Soak Time	60-120 sec
$T_{\text{Liquidus}}$	217°C
Time above $T_{\text{Liquidus}}$	60-150 sec
$T_{\text{peak}}$	250°C
Time within 5° of $T_{\text{peak}}$	20-30 sec
Time from 25° to $T_{\text{peak}}$	8 min max
Ramp Down Rate	6°C/sec max

### Pb-Free Solder Paste

Use of “No Clean” soldering paste is strongly recommended, as it does not require cleaning after the soldering process.

**Note:** *The quality of solder joints on the castellations (“half vias”) where they contact the host board should meet the appropriate IPC Specification. See the Castellated Terminations Section in the latest IPC-A-610 Acceptability of Electronic Assemblies document.*

### Cleaning

In general, cleaning the populated module is strongly discouraged. Residuals under the module cannot be easily removed with any cleaning process.

- Cleaning with water can lead to capillary effects where water is absorbed into the gap between the host board and the module. The combination of soldering flux residuals and encapsulated water could lead to short circuits between neighboring pads. Water could also damage any stickers or labels.
- Cleaning with alcohol or a similar organic solvent will likely flood soldering flux residuals into the two housings, which is not accessible for post-washing inspection. The solvent could also damage any stickers or labels.
- Ultrasonic cleaning could damage the module permanently.

The best approach is to consider using a “No Clean” solder paste and eliminate the post-soldering cleaning step.

### Optical Inspection

After soldering the module to the host board, consider optical inspection to check the following:

- Proper alignment and centering of the module over the pads
- Proper solder joints on all pads
- Excessive solder or contacts to neighboring pads or vias

### Repeating Reflow Soldering

Only a single reflow soldering process is encouraged for host boards.

## Wave Soldering

If a wave soldering process is required on the host boards due to the presence of leaded components, only a single wave soldering process is encouraged.

## Hand Soldering

Hand soldering is possible. When using a soldering iron, follow IPC recommendations (reference document *IPC-7711*).

## Rework

The Cortet module can be unsoldered from the host board. Use of a hot air rework tool should be programmable and the solder joint and module should not exceed the maximum peak reflow temperature of 250°C.

## Caution

If temperature ramps exceed the reflow temperature profile, module and component damage may occur due to thermal shock. Avoid overheating.

## Warning

Never attempt a rework on the module itself (i.e., replacing individual components); such actions will terminate warranty coverage.

## Additional Grounding

Attempts to improve the module or the system grounding by soldering braids, wires or cables onto the module RF shield cover is done at the customer's own risk. The ground pins at the module perimeter should be sufficient for optimum immunity to external RF interference.

## AGENCY CERTIFICATIONS

**NOTE: Certifications are in process and pending final approval**

### FCC Compliance Statement Part 15.19, Section 7.15 of RSS-GEN

This device complies with Part 15 of the FCC Rules and with Industry Canada licence-exempt RSS Standards. Operation is subject to the following two conditions:

1. This device may not cause harmful interference, and
2. This device must accept any interference received, including interference that may cause undesired operation.

Le présent appareil est conforme aux CNR d'Industrie Canada applicables aux appareils radio exempts de licence. L'exploitation est autorisée aux deux conditions suivantes:

1. l'appareil ne doit pas produire de brouillage, et
2. l'utilisateur de l'appareil doit accepter tout brouillage radioélectrique subi, même si le brouillage est susceptible d'en compromettre le fonctionnement.

### Warning (Part 15.21)

Changes or modifications not expressly approved by CEL could void the user's authority to operate the equipment.

### 20cm Separation Distance

To comply with FCC/IC RF exposure limits for general population/uncontrolled exposure, the antenna(s) used for this transmitter must be installed to provide a separation distance of at least 20cm from all persons and must not be co-located or operated in conjunction with any other antenna or transmitter.

### OEM Responsibility to the FCC and IC Rules and Regulations

The Cortet Mini Module has been certified per FCC Part 15 Rules and to Industry Canada license exempt RSS Standards for integration into products without further testing or certification. To fulfill the FCC and IC certification requirements, the OEM of the Cortet Module must ensure that the information provided on the Cortet label is placed on the outside of the final product. The Cortet Mini Module is labeled with its own FCC ID number and IC ID number. If the FCC ID and the IC ID are not visible when the module is installed inside another device, then the outside of the device into which the module is installed must also display a label referring to the enclosed module. The exterior label can use wording such as the following

"Contains Transmitter Module FCC ID: W7Z-WB4343S"

"Contains Transmitter Module IC: 8254A-WB4343S"

The OEM of the Cortet Mini Module may only use the approved antennas (PCB Trace Antenna) that have been certified with this module. The OEM of the Cortet Mini Module must test their final product configuration to comply with Unintentional Radiator Limits before declaring FCC Compliance per Part 15 of the FCC Rules.

### IC Certification — Industry Canada Statement

The term "IC" before the certification/registration number only signifies that the Industry Canada technical specifications were met.

### Certification IC — Déclaration d'Industrie Canada

Le terme "IC" devant le numéro de certification/d'enregistrement signifie seulement que les spécifications techniques Industrie Canada ont été respectées.

### Section 14 of RSS-210

The installer of this radio equipment must ensure that the antenna is located or pointed such that it does not emit RF field in excess of Health Canada limits for the general population. Consult Safety Code 6, obtainable from Health Canada's website: [http://www.hc-sc.gc.ca/ewh-semt/pubs/radiation/radio\\_guide-lignes\\_direct-eng.php](http://www.hc-sc.gc.ca/ewh-semt/pubs/radiation/radio_guide-lignes_direct-eng.php)

### L'article 14 du CNR-210

Le programme d'installation de cet équipement radio doit s'assurer que l'antenne est située ou orientée de telle sorte qu'il ne pas émettre de champ RF au-delà des limites de Santé Canada pour la population générale. Consulter le Code de sécurité 6, disponible sur le site Web de Santé Canada: [http://www.hc-sc.gc.ca/ewh-semt/pubs/radiation/radio\\_guide-lignes\\_direct-eng.php](http://www.hc-sc.gc.ca/ewh-semt/pubs/radiation/radio_guide-lignes_direct-eng.php)



**SHIPMENT, HANDLING AND STORAGE**

**Shipment**

The Cortet modules are delivered in reels of 600 units. The reel diameter is 12.992 inches (330mm).

**Tape and Reel Dimensions**  
Measurements are in inches [mm]

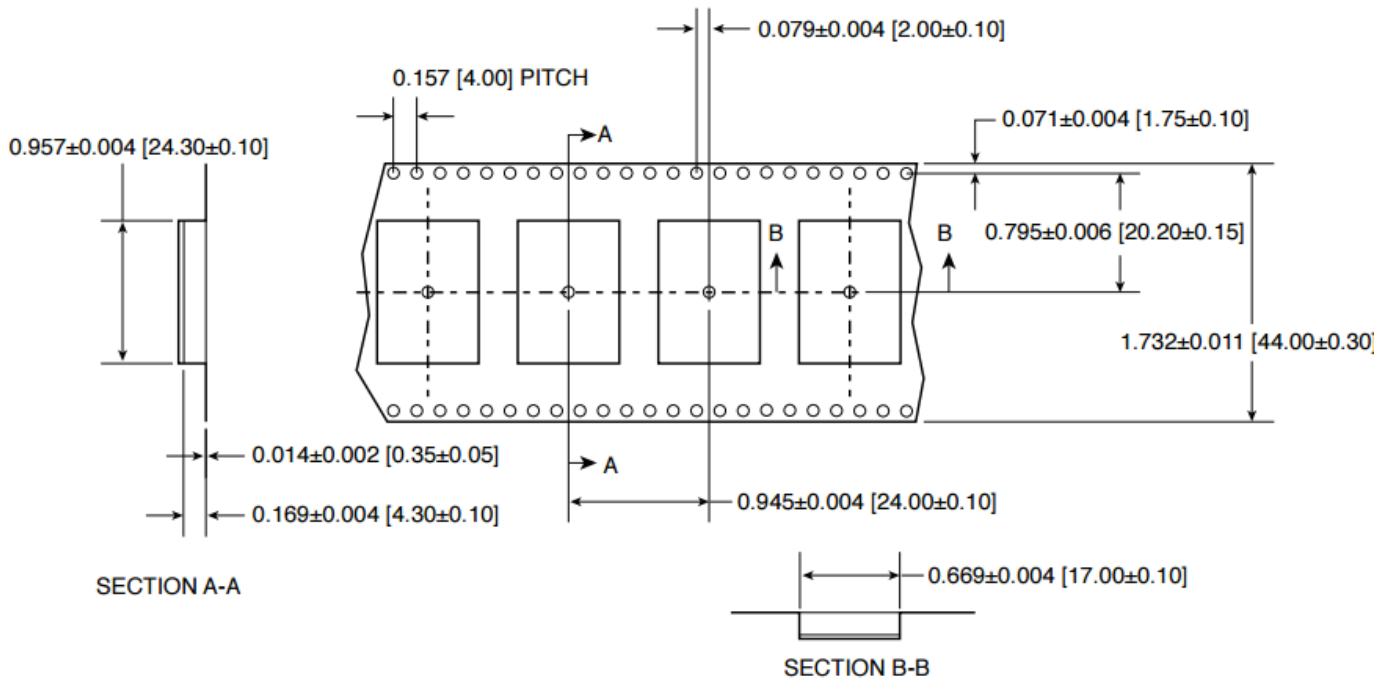

**Handling**

The Cortet modules are designed and packaged to be processed in an automated assembly line.

**Warning**

The Cortet modules contain highly sensitive electronic circuitry. Handling without proper ESD protection may destroy or damage the module permanently.

**Warning**

The Cortet modules are moisture-sensitive devices. Appropriate handling instructions and precautions are summarized in J-STD-033. Read carefully to prevent permanent damage due to moisture intake.

**Moisture Sensitivity Level (MSL)**

MSL 3, per J-STD-033

**Storage**

Storage/shelf life in sealed bags is 12 months at <40°C and <90% relative humidity.

**QUALITY**

CEL modules offer the highest quality at competitive prices. Our modules are manufactured in compliance with the IPC-A-610 specification, Class II. Our modules go through JESD22 qualification processes which includes high temperature operating life tests, mechanical shock, temperature cycling, humidity and reflow testing.

CEL builds the quality into our products, giving our customers confidence when integrating our products into their systems.

**REVISION HISTORY**

Previous Versions	Changes to Current Version	Page(s)
0021-00-07-00-000 (Issue A) January 22, 2016	Initial Preliminary Data Sheet	N/A
0021-00-07-00-000 (Issue B) May 23, 2016	Revisions to Entire Document	N/A

**DISCLAIMER**

The information in this document is current as of the published date. The information is subject to change without notice. For actual design-in, refer to the latest publications of CEL Data Sheets or Data Books, etc., for the most up-to-date specifications of CEL products. Not all products and/or types are available in every country. Please check with a CEL sales representative for availability and additional information.

No part of this document may be copied or reproduced in any form or by any means without the prior written consent of CEL. CEL assumes no responsibility for any errors that may appear in this document.

CEL does not assume any liability for infringement of patents, copyrights or other intellectual property rights of third parties by or arising from the use of CEL products listed in this document or any other liability arising from the use of such products. No license, express, implied or otherwise, is granted under any patents, copyrights or other intellectual property rights of CEL or others.

Descriptions of circuits, software and other related information in this document are provided for illustrative purposes in semiconductor product operation and application examples. The incorporation of these circuits, software and information in the design of a customer's equipment shall be done under the full responsibility of the customer. CEL assumes no responsibility for any losses incurred by customers or third parties arising from the use of these circuits, software and information.

**FOR MORE INFORMATION**

For more information about CEL Cortet products and solutions, visit our website at [cortet.cel.com](http://cortet.cel.com).

**TECHNICAL ASSISTANCE**

For Technical Assistance, visit [cortet.cel.com/tech-support](http://cortet.cel.com/tech-support).