

Calphalon® 

XL Digital Convection Oven
USER GUIDE
Model HE700CO



Thank you for choosing a Calphalon XL Digital Convection Oven.

The **Calphalon Kitchen Electrics** collection features our exclusive **Opti-Heat System**. Designed to provide accurate temperature control and even heat delivery, Opti-Heat ensures that foods cook evenly and thoroughly, for reliable results you can count on – every time.

We know you are excited to begin using your convection oven; this User Guide is designed to help you make the most of your new appliance.

Be sure to carefully review this guide before using your convection oven and keep it handy for future reference should you have any questions about your convection oven’s operation.

TABLE OF CONTENTS

Safety Instructions	page 1
Getting to Know Your Convection Oven	page 5
Parts & Features	
Operating Your Convection Oven	page 6
Before the First Use	
Setting the Controls	
Tips for Successful Operation	page 13
Bake	page 13
Broil.....	page 16
Toast	page 18
Bagel	page 21
Pizza	page 23
Cookies	page 25
Cleaning and Care	page 28
Before Cleaning	
Cleaning the Crumb Tray	
Cleaning the Convection Oven	
Storage	page 29
Frequently Asked Questions	page 30
Warranty	page 32
Recipes	page 34

NOTE: If you have additional questions or concerns, or wish to return product(s), please contact **Calphalon Customer Service** at **1-800-809-7267**. Please do not return this product to the store.

SAFETY INSTRUCTIONS

The safety instructions appearing in this guide are not meant to cover all possible situations that may occur. Caution must be exercised when installing, maintaining or operating this appliance. Contact your dealer, distributor, service agent or manufacturer with any issues you do not understand.

Recognize Safety Messages

Always read and obey the safety messages included in this guide. Look for the following safety symbols, which will alert you to potential hazards.



WARNING – Hazards or unsafe practices which **COULD** result in severe personal injury or death.



CAUTION – Hazards or unsafe practices which **COULD** result in minor personal injury.



ATTENTION! The convection oven may emit a light smoke and/or odor as it heats up during the first few minutes of operation. This is due to residual oils left over from the manufacturing process; this is common for any type or brand of convection oven and is not a defect. This will dissipate quickly and is not a reason for concern.

IMPORTANT SAFEGUARDS

When using electrical appliances, basic safety precautions should always be observed, including the following:

1. READ ALL INSTRUCTIONS in this guide before attempting to operate your appliance.
2. Do not touch hot surfaces. Appliance surfaces are hot during and after use. To prevent burns or personal injury, use handles and knobs and hot pads or oven mitts.
3. To protect against electrical shock do not immerse the convection oven, cord or plug in water or other liquids.
4. Close supervision is necessary when any appliance is used by or near children.
5. Unplug from outlet when not in use and before cleaning. To disconnect, remove the plug from the outlet. Allow to cool before putting on or taking off parts.
6. Do not operate any appliance with a damaged cord or plug or after the appliance malfunctions, is dropped or damaged. Contact **Calphalon Customer Service** at **1-800-809-7267** for examination, repair, or adjustment.
7. Use only the accessories supplied with this convection oven. Using attachments not recommended or sold by Calphalon may cause injuries.
8. Do not use outdoors.
9. Do not let the cord hang over the edge of a table or counter, touch hot surfaces, or become knotted.
10. Do not place the convection oven on or near a hot gas, electric or induction burner, or in a heated oven.
11. Extreme caution must be used when moving an appliance containing hot oil or other hot liquids. Use extreme caution when removing pans, dishes and/or accessories containing hot oil or other hot liquids.
12. This product is designed for household use only. Do not use appliance for other than intended purpose.
13. Oversized foods or metal utensils must not be inserted in the convection oven as they may create a fire or risk of electric shock.
14. A fire may occur if the convection oven is covered, touching or near any flammable material, including fabrics, wall coverings, towels, curtains, or like materials when in operation. Do not store any item on top of the appliance when in operation.
15. Do not clean the convection oven with metal scouring pads. Pieces can break off the pad and touch electrical parts, creating a risk of electric shock.

16. Extreme caution should be exercised when using containers or baking pans constructed from materials other than metal or glass.
17. Do not store any materials, other than manufacturers recommended accessories, in this oven when not in use.
18. Do not place any of the following materials in or under the oven: paper towels, cardboard, paper or plastic.
19. Do not cover crumb tray or any part of the oven with metal foil. This will cause overheating of the oven.
20. In case of malfunction, the convection oven may be turned off by pressing the Start/Cancel button. Once turned off, carefully unplug the cord from the outlet. Do not unplug the convection oven by pulling on the power cord. Always grasp the plug and pull to disconnect.
21. Do not use convection oven as a source for heat or for drying.
22. The appliance must only be used in the upright position, never lying down, tilted or upside down. Always use the convection oven on a dry, level surface. Never operate the convection oven near the edge of a countertop or table.
23. Empty the crumb tray regularly. Remove the power plug from the outlet and cool before cleaning. Failure to do so may result in a fire hazard.
24. Do not use the convection oven without the clean, dry crumb tray in place.
25. This appliance is not intended for use by children or other persons, without assistance or supervision, if their physical, sensory or mental capabilities prevent them from using it safely.
26. Remove and safely discard any packing materials before using the convection oven for the first time.
27. Never leave the convection oven unattended when in use.
28. Do not allow hot surfaces of the convection oven to come in contact with countertops or tables.
29. When operating the convection oven keep a minimum distance of 4" (10 cm) of space on both sides of the appliance. This allows for air circulation.
30. Carefully follow the **Cleaning and Care** instructions on **page 28** when cleaning your convection oven to avoid risk of injury or shock hazards.

SAVE THESE INSTRUCTIONS FOR FUTURE REFERENCE.

NOTE: If this convection oven malfunctions during use, immediately press the Start/Cancel button to cancel the cycle. Unplug the power cord from the electrical outlet. Do not use or attempt to repair the convection oven. Contact **Calphalon Customer Service** at **1-800-809-7267** for examination, repair, or adjustment.

ELECTRICAL REQUIREMENTS



Avoid Electric Shock

This product has a polarized power cord plug, meaning one blade on the plug is wider than the other. The plug will fit into a polarized electrical outlet only one way. To reduce the risk of electrical shock, do not force the plug into an outlet. If the plug won't fit into the outlet, reverse the plug. If it still will not fit into the outlet, contact a qualified electrician to modify the outlet. Do not modify the cord plug in any way.

This appliance is equipped with a 3-prong grounding plug for your protection against shock hazard and it should be plugged directly into a properly grounded receptacle. Do not cut or remove the grounding prong from this plug. If the plug fails to fit into an existing outlet, contact a qualified electrician to update the outlet.

Short Cord Instructions

Your Calphalon convection oven has a short power supply cord as a safety precaution to prevent personal injury or property damage resulting from becoming entangled with a longer cord. Do not allow children to be near this appliance without adult supervision. Longer detachable extension cords are available and may be used if care is exercised in their use.

If an extension cord is used:

The extension cord must be a grounding-type 3-wire cord. A short power-supply cord should be used to reduce the risk resulting from becoming entangled in or tripping over a longer cord. Extension cords are available and may be used if care is exercised in their use. If an extension cord is used, the marked electrical rating of the cord set or extension cord should be at least as great as the electrical rating of the appliance and the cord should be arranged so that it will not drape over the countertop or tabletop where it can be pulled on by children or tripped over unintentionally.

SAVE THESE INSTRUCTIONS FOR FUTURE REFERENCE.

GETTING TO KNOW YOUR CONVECTION OVEN



Parts and Features

- 1. Brushed, Stainless Steel Exterior** – Durable and sleek
- 2. High Performance Bronze Nonstick Interior** – For easy cleaning
- 3. Heavy Gauge Oven Rack** – With three optional positions
- 4. Convection Fan** – Circulates warm air around foods for superior baking results
- 5. LCD Panel** – Features an easy-to-read, illuminated display
- 6. Time Remaining** – Two hour digital timer displays the cooking time
- 7. Real Time Temperature Display** – Indicates set temperature of oven
- 8. Start/Cancel Button** – Starts or cancels a cooking cycle
- 9. Mode** – Indicates a choice of six cooking modes: Bake, Broil, Toast, Bagel, Pizza and Cookies
- 10. Defrost Button** – For defrosting and cooking your favorite frozen foods; customized for specific cooking modes
- 11. Convection Button** – Activates the convection fan for baking
- 12. Time/Slices Knob** – Selects the desired cooking/toasting time - based on minutes or number of bread slices
- 13. Temp/Shade Knob** – Selects the desired cooking temperature (ranging from 150°F/65°C to 450°F/232°C) or darkness level (ranging from a low of one to a high of nine).
- 14. Nonstick Baking Pan** – This 9 x 10 inch pan is specially designed for use in the convection oven
- 15. Crumb Tray** – Removes for easy clean up

OPERATING YOUR CONVECTION OVEN

Before the First Use

1. Carefully remove the convection oven from the packaging and place on counter near a suitable electrical outlet. (See page 4 for information regarding Electrical Requirements.)
2. Remove any stickers or temporary labels on the convection oven and any packing materials inside the oven.
3. Place the convection oven on a clean, dry, sturdy surface that is clear from any potentially flammable materials.
4. Before the first use, wash the oven rack and nonstick baking pan in warm soapy water.
5. Plug the power cord into a suitable 120 V electrical outlet away from the edge of a counter or table. The oven will chime, the start button will blink indicating it is awaiting input.
6. When powered on, default settings for the convection oven are displayed. The oven is set to Bake for 10 minutes at 350 °F with the convection function activated.
7. Continue with steps for “Setting the Controls”.

CAUTION

To reduce the risk of electric shock, insert the polarized plug (with one blade wider than the other) into a polarized outlet. If the plug does not fit into the outlet completely, reverse the plug. If it still does not fit, contact a qualified electrician. Do not attempt to modify the plug in any way.

WARNING

Fire may occur if the convection oven is covered, touching or near any flammable materials, including fabrics, wall coverings, towels, curtains, or like materials when in operation.

Setting the Controls

The First Use

ATTENTION

For the first use, we suggest preheating the convection oven without food to burn off any oils used in the manufacturing process. The oven may emit a light smoke or odor as it heats up during the first few minutes of operation. This will dissipate quickly and is not a reason for concern.

1. When powered on, default settings for the convection oven are displayed. The oven is set to Bake for 10 minutes at 350°F with the convection fan activated.
2. Turn the Temp/Shade knob to the right to select the highest setting 450°F.
3. Press Start.
4. Allow the empty convection oven to complete the 10 minute baking cycle while any light smoke or odor dissipates.

Sleep Mode: While setting the controls, please NOTE that if the convection oven sits for three minutes without being activated, it will go into Sleep mode. To bring the oven out of Sleep Mode, press any button.

Step 1: CHOOSE A RACK POSITION

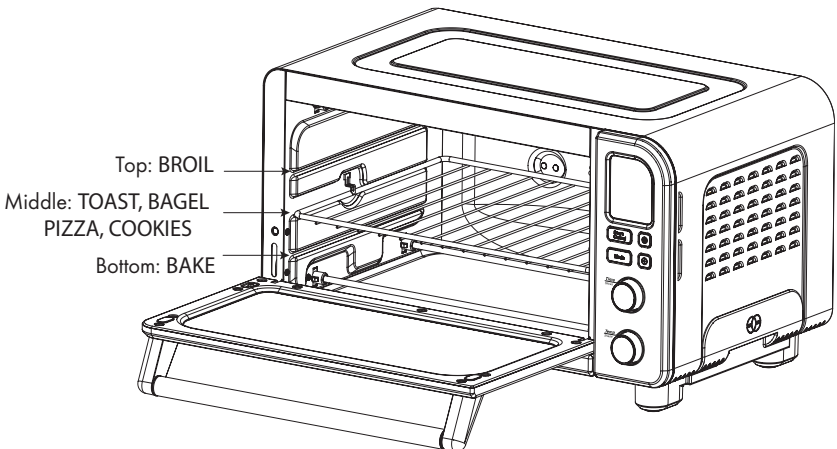

Based on the desired cooking mode, move the rack, if needed, to the appropriate position:

Top rack position – Broil

Middle rack position * – Toast, Bagel, Pizza and Cookies

Bottom rack position – Bake

***NOTE:** The middle rack has a safety hook to prevent the rack from falling out when removed. To remove the rack, tilt upward and pull forward. The reverse process is needed to reinstall the rack.

Allow at least 1/2-inch of space between the pan of food and the heating elements. Adjust the rack position, as needed, to allow proper clearance.

Make sure the rack is level and securely in place before moving to Step 2.

Step 2: SELECT A MODE

When powered on, default settings for the convection oven are displayed. The oven is set to Bake for 10 minutes at 350 °F with the convection fan active. Once a cooking mode is selected, a default time and temperature for that setting is displayed. These settings may also be changed to suit your needs.

Press the Mode button and select one of six cooking modes:

Bake – Choose for traditional baked goods, as well as for roasted meats, fish, poultry and vegetables.

Broil – Choose for broiling small cuts of meat, fish or poultry, and for browning crumb toppings or melting cheese on top of foods.

Toast – Choose for toasting slices of bread, as well as bread products such as toaster pastries and waffles.

Bagel – Choose for toasting only the cut sides of bagels or English muffins.

Pizza – Choose for baking either fresh or frozen pizzas.

Cookies – Choose for baking fresh or frozen cookies.

Step 3: SELECT CONVECTION OR DEFROST MODES (Optional)



Convection

If desired, press the Convection button to activate the convection fan.

NOTE: The Convection option is available when using the following modes: Bake, Pizza and Cookies.

The convection fan circulates warm air in the oven, which browns foods and creates a golden crust on baked goods. Using convection helps create more even baking results.



Defrost

If desired, press the Defrost button for frozen foods.

NOTE: Defrost is available when using the following modes: Pizza, Cookies, Toast or Bagel.

Choose defrost if you are cooking/toasting a frozen food such as frozen bagels, pastry strudels, and pizza. The Defrost setting is customized for each cooking mode selected. The Defrost setting extends the cooking cycle to bake/toast frozen foods. Additional cook time may be required by the user.

Step 4: CHOOSE THE TIME

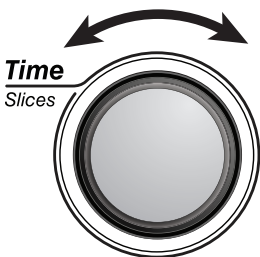

Bake, Broil, Pizza and Cookies -

Turn the Time/Slices knob to select the desired cook time. The time may be adjusted in one minute increments up to a maximum of two hours. Turn the knob to the right to increase the time and to the left to decrease the time.

Toast or Bagel - Turn the Time/Slices knob to select the number of bread slices. You may select

up to six slices. Turn the knob to the right to increase the number of slices and to the left to decrease the number of slices.

Step 5: CHOOSE THE TEMPERATURE

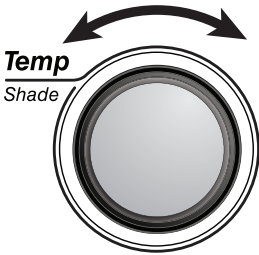

Bake, Pizza and Cookies – Turn the Temp/Shade knob to select the desired temperature, which is displayed in five degree increments from 150 °F to 450 °F. Turn the knob to the right to increase the temperature and to the left to decrease it.

Broil – Turn the Temp/Shade knob to select either HI or LO broil.

Toast or Bagel – Turn the Temp/Shade knob to select the desired level of browning, with shade one being the lightest and shade nine being the darkest. Turn the knob to the right to increase the level of darkness and to the left to decrease it.

Real Time Temperature Display – The convection oven is equipped with real time temperature feedback. The LCD will display the current oven temperature during the pre-heating phase in order to communicate the pre-heat progress of the oven.

Once the oven temperature stabilizes to the desired set point, the oven will no longer display real time temperature feedback. The temperature control of the oven is designed to be highly accurate in order to achieve optimal cooking results.

As a result, you will hear the thermostat turning on and off periodically indicating that the oven is maintaining accurate temperature control.

Step 6: BEGIN COOKING

For Bake, Broil, Pizza or Cookie Modes:



1. Press Start to begin preheat. Preheating will flash on the display until the selected oven temperature is reached.
2. Insert food once chime sounds and temperature/preheat is no longer blinking on the oven display. Time starts automatically.

Place food on baking pan or oven rack. Place food on the 9 x 10 inch nonstick baking pan supplied with the convection oven. Or, select a pan that fits within the oven cavity up to a 9 x 13-inch pan. Do not use over-sized pans that touch the oven walls or keep the door from closing. Open the oven door and, carefully place the baking pan on the oven rack.

Be sure to allow at least ½-inch of space between the pan of food you are inserting and the heating elements.

Close oven door. Using the handle, and being careful not to touch hot surfaces, securely close the oven door.

Remove food once timer ends and chime sounds.

For Toast or Bagel Modes:

- 1.** Insert toast or bagels directly on oven rack (bagels should face cut side up). Be sure to allow at least ½-inch of space between the food you are inserting and the heating elements. Close oven door. Using the handle, and being careful not to touch hot surfaces, securely close the oven door.
- 2.** Press Start to begin the toasting process.
- 3.** Remove toast or bagels once timer ends and chime sounds.



⚠ WARNING

Inserting oversized foods, metal utensils or materials of any kind may cause risk of fire or electric shock.

Sleep Mode

If the convection oven sits for three minutes and the flashing Start/Cancel button is not pressed, the convection oven will go into Sleep mode. To bring the oven out of Sleep mode, touch any button.

Step 7: CHANGING/CANCELING A COOKING CYCLE



Changing a Cycle

Mode – You may not change the cooking mode while the oven is operating. Instead, turn the oven off by pressing the Start/Cancel button. Then reset the controls as desired.

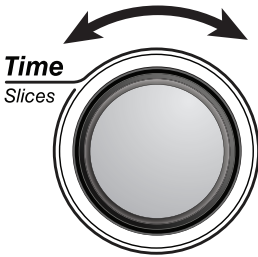

Time/Slices and Temp/Shade – To change these settings while the oven is operating, simply turn the corresponding knobs to select the desired setting.

Defrost and Convection – To activate or deactivate these settings while the oven is operating, press the corresponding button.

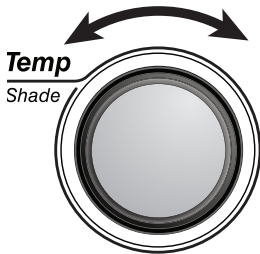

Canceling a Cycle

If you need to turn off the convection oven for any reason while cooking, simply press the Start/Cancel button. To disconnect the convection oven, be sure to grasp the plug securely, rather than the power cord, when removing it from the outlet.

WARNING

If this convection oven malfunctions during use, immediately press the Start/Cancel button to cancel the cycle. Unplug the power cord from the electrical outlet. Do not use or attempt to repair the convection oven. Contact **Calphalon Customer Service** at **1-800-809-7267** for examination, repair, or adjustment.

TIPS FOR SUCCESSFUL OPERATION

As you become familiar with your convection oven, we want to share a few suggestions for baking, roasting, broiling and toasting common foods.

BAKE



How it Works

When choosing Bake mode, the top and bottom heating elements cycle on and off, maintaining a constant temperature to bake foods from above and below.

When to Use This Setting

Choose for traditional baked items such as cakes, breads and muffins, as well as for roasted meats, fish, poultry and vegetables.

- **Preheat** – Yes
- **Rack Position** – Bottom
- **Recommended Baking Pans** – Metal and glass baking pans are suggested. The nonstick 9 x 10-inch Calphalon baking pan provided with the convection oven works well for many foods. Other pans that fit inside the oven are 9 x 13-inch baking pans, 6-cup muffin tins, 9-inch pie plates, 9-inch bread pans, 8-inch square baking pans, and small baking sheets.

Options

Convection Mode

Choose this mode if you are baking items such as breads, two-crust pies or muffins. Also select convection when roasting vegetables, fish, poultry or meat.

The convection fan circulates warm air in the oven, which browns foods and creates a golden crust on baked goods. Using convection helps create more even baking results.

The optional Defrost setting is not available while using the Bake mode. If you try to select this option the convection oven will chime three times to indicate this setting is not active during the Bake mode.

Setting the Controls for Baking

1. Make sure the convection oven is properly plugged in and ready for operation. (See **Electrical Requirements** on **page 4** for further instructions.)
2. Place the oven rack in the bottom position. Check to make sure the rack position allows at least ½-inch of space between the pan of food and the heating element.
3. When powered on, default settings for the convection oven are displayed. The oven is set to Bake for 10 minutes at 350° F with the convection function activated.
4. Turn the Time/Slices knob to select the desired cooking time. Turn right to increase the time and left to decrease the time. The time may be set in 1 minute increments up to a maximum of two hours.
5. Turn the Temp/Shade knob to select the desired oven temperature. Turn right to increase the temperature and left to decrease it. The temperature may be set in 5 degree increments from a minimum of 150° F to a maximum of 450° F.
6. Press the Start/Cancel button. The oven begins preheating. Preheating will flash on the display until the selected oven temperature is reached.
7. Once preheated, the oven will chime, the desired temperature will illuminate on the display, and the timer will begin counting down.
8. Insert the food into the oven on a baking pan.

Recommended Baking Times and Temperatures

Times and temperatures are the same as for traditional ovens. Simply follow the package directions and recipe instructions for recommended baking times and temperatures. Refer to our baking chart (shown next page) for general guidelines.

Baking Chart

Food	Approx. Time	Approx. Temperature
Muffins	13 to 20 minutes	400° F
Biscuits/shortcakes	10 to 15 minutes	450° F
Quick breads	50 to 55 minutes	350° F
Scones	10 to 15 minutes	400° F
Yeast breads	35 to 40 minutes	375° F
Cakes (4 round)	20 to 25 minutes	325° F
Pork tenderloin	20 to 25 minutes (or until 160° F medium)	425° F
Boneless, fully-cooked ham	27 to 33 minutes per lb.	325° F
Boneless chicken breast halves (4 oz)	30 minutes (or until 165° F)	375° F
Chicken legs or thighs	40 to 50 minutes (or until 165° F)	350° F
Cornish hens	50 to 60 minutes	350° F
Fresh fish fillets (per ½-in. thickness)	4 to 6 minutes (or until it flakes with a fork)	450° F
Root vegetables, chopped	30 to 40 minutes	425° F
Baked potatoes	45 minutes	400° F

BROIL



How it Works

When choosing Broil mode, the top heating elements cycle on and off to cook foods from the top down. Broil with the door open for short cooking times, less than 10 minutes, to add crispness to items like open-faced sandwiches and nachos. Broil with the door closed for tender items like fish.

When to Use This Setting

Select Broil for small cuts of meat, fish or poultry, and for browning crumb toppings or melting cheese on casseroles or garlic bread.

- **Preheat** – Yes
- **Rack Position** – Top or Middle (allowing at least ½-inch between the pan of food and the upper heating elements).
- **Recommended Broiling Pans** – Metal baking pans are suggested for broiling. The nonstick 9 x 10-inch Calphalon baking pan provided with the convection oven works well for many foods. You may also use other shallow baking pans suitable for broiling.

WARNING

Avoid a fire hazard by choosing suitable pans for broiling meats. Broiled meats accumulate juices while cooking. Choose broiling pans with sides to catch the drippings and prevent them from spilling into the bottom of the convection oven. Make sure there is at least ½-inch of clearance between the pan of food and the heating elements.

Options

The optional Defrost and Convection settings are not available while using the Broil mode. If you try to select these options the convection oven will chime three times to indicate these settings are not active during the Broil mode.

Setting the Controls for Broiling

1. Make sure the convection oven is properly plugged in and ready for operation. (See **Electrical Requirements** on **page 4** for further instructions.)
2. Place the oven rack in the top position. Check to make sure the rack position allows at least ½-inch of space between the pan of food and the heating element. If there is not enough space, move the pan to the middle rack position.
3. When powered on, default settings for the convection oven are displayed. The oven is set to Bake for 10 minutes at 350 °F with the convection function activated.
4. Press the Mode button to select the Broil setting.
5. A default time and temperature of 3 minutes on HI broil appear.
6. If desired, turn the Time/Slices knob to adjust the cooking time, as needed. Turn right to increase the time and left to decrease the time. The time may be set in 1 minute increments up to a maximum of 2 hours.
7. Turn the Temp/Shade knob to select the desired broil setting of either HI or LO. HI broil is 400 °F and LO broil is 300 °F.
8. Press the Start/Cancel button. The oven begins preheating. Preheating will flash on the display until the selected broil temperature is reached.
9. Once preheated, the oven will chime, the desired broil setting will illuminate on the display, and the timer will begin counting down.
10. Insert the food into the oven on a baking pan.
11. Leave the door open slightly (where it catches) during broiling for short cooking times to add crispness.

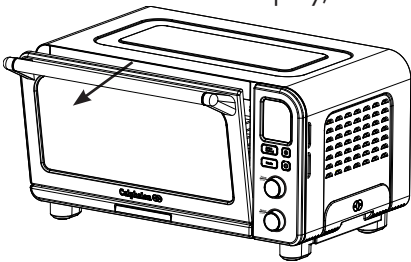

Recommended Broiling Times and Temperatures

Times and temperatures are the same as for traditional ovens. Simply follow the package directions on your favorite foods or recipe instructions from cookbooks for recommended broiling times and temperatures.

Turn the foods over halfway through broiling to brown on both sides and cook throughout.

HI broil – Use for denser foods such as hamburger patties, steaks, and pork chops.

LO broil – Use for more delicate broiling such as chicken breast halves, and fresh fish filets.

Broiling Chart

Food	Approx. Time	Approx. Temperature
Beef steaks (¾-inch) (1-inch)	4 to 5 minutes per side 6 to 7 minutes per side (or until 145 °F)	HI broil
Fresh hamburger patties (¾-inch)	6 to 7 minutes per side (or until 160 °F)	HI broil
Pork chops (¾-inch)	4 to 5 minutes per side (or until 160 °F)	HI broil
Boneless chicken breast halves (4 oz)	10 to 15 minutes per side (or until 165 °F)	LO broil
Fresh fish filets (1-inch)	6 to 8 minutes per side (or until flakes with fork)	LO broil

TOAST



How it Works

When choosing Toast mode, the top heating elements toast foods from above and the bottom heating elements.

When to Use This Setting

Choose for toasting slices of white, wheat and whole grain breads. Also select this mode for toasting bread products such as toaster pastries and waffles.

- **Preheat** – No
- **Rack Position** – Middle
- **Recommended Pans for Toasting** – A pan is not needed for toasting. To allow proper toasting of bread slices, waffles and toaster pastries from both top and bottom, place directly on the oven rack provided with the convection oven.

Tips for Preparing Bread/ Bread Products for Toasting

- Begin by selecting uniform slices of bread or bread products to toast at the same time. This will ensure even browning.
- Make sure slices of bread, waffles or pastries fit comfortably in the convection oven. The oven is designed to hold a maximum of six standard slices of bread.
- When toasting less than four slices of bread, make sure that the slices are positioned directly over the heating elements and not across the middle of the oven rack.
- Use caution when toasting pastries or strudels. Quickly inspect the pastries to make sure they do not have any leaking filling that may drip out when warm.

Options

Defrost mode

Choose Defrost if you are toasting frozen foods such as waffles or pastries. The Defrost setting extends the cooking cycle to toast frozen foods.

The optional Convection setting is not available to use during the Toast mode. If you try to select this option the convection oven will chime to indicate this setting is not active during the Toast mode.

Setting the Controls for Toasting

1. Make sure the convection oven is properly plugged in and ready for operation. (See **Electrical Requirements** on **page 4** for further instructions.)
2. Place the oven rack in the middle position. The middle rack position has a safety hook to prevent the rack from falling out when it is removed. To remove the rack, tilt upward and pull forward. The reverse process is needed to reinstall the rack.

3. When powered on, default settings for the convection oven are displayed. The oven is set to Bake for 10 minutes at 350 °F with the convection function activated.
4. Press the Mode button to select the Toast setting.
5. A default setting of four slices and a darkness level four appears.
6. If toasting a frozen bread or bread product, press the Defrost button. It will illuminate when activated. (Learn more about the Defrost mode as described above under Options.)
7. Turn the Time/Slices knob to adjust the number of slices, as needed. Turn right to increase the number of slices and left to decrease. The number may be set as low as one slice or as high as six slices.
8. If desired, turn the Temp/Shade knob to select the level of darkness. Choose between a minimum of level one (for lightest browning) and a maximum of level nine (for the darkest browning).
9. Insert the bread/bread products into the oven directly on the oven rack.
10. Press the Start/Cancel button.
11. The display will show the toasting time remaining.

Recommended Toasting Times and Temperatures

As you become familiar with your convection oven, we want to share a few suggestions for toasting common breads and bread products.

Suggested Convection Oven Settings

The following chart is meant to serve as a general guide for choosing the appropriate convection oven settings. You can experiment to identify your preferred toasting setting.

Toasting Chart

Type of Bread	Setting (for medium browning)
White sandwich breads	Shade level four
Wheat or rustic breads	Shade level six
Toaster pastry tarts	Shade level four
Frozen waffles	Shade level six and Defrost
Frozen toaster pastries/scrambles	Shade level four and Defrost

BAGEL



How it Works

When choosing the Bagel mode, the upper heating elements toast foods on top and the bottom heating elements cycle on and off to warm them on the bottom.

When to Use This Setting

Choose for toasting the cut sides of dense, sliced bread products such as bagels or English muffins.

- **Preheat** - No
- **Rack Position** - Middle
- **Recommended Pans for Toasting** - A pan is not needed for toasting. To allow proper toasting of bread products such as bagels or English muffins, place them directly on the oven rack provided with the convection oven. Slice the bagels and/or English muffins in half and place on the oven rack with the cut sides facing up.

Tips for Preparing Bagels and/or English Muffins for Toasting

- Begin by selecting uniform slices of bagels or English muffins to toast at the same time. This will ensure even browning.
- Make sure slices of bagels and/or English muffins fit comfortably in the convection oven. The oven is designed to hold the equivalent of a maximum of six bagel halves.
- When inserting bagels and/or English muffins in the convection oven, position the cut sides facing up.

Options

Defrost mode

Choose Defrost if you are toasting frozen bagels or English muffins. The Defrost setting extends the cooking cycle to toast frozen foods. Additional cook time may be required by the user.

The optional Convection setting is not available to use during the Bagel mode. If you try to select this option the convection oven will chime three times to indicate this setting is not active during the Bagel mode.

Setting the Controls for Bagel Mode

1. Make sure the convection oven is properly plugged in and ready for operation. (See **Electrical Requirements** on **page 4** for further instructions.)
2. Place the oven rack in the middle position. The middle rack position has a safety hook to prevent the rack from falling out when it is removed. To remove the rack, tilt upward and pull forward. The reverse process is needed to reinstall the rack.
3. When powered on, default settings for the convection oven are displayed. The oven is set to Bake for 10 minutes at 350° F with the convection function activated.
4. Press the Mode button to select the Bagel setting.
5. A default setting of four slices and a darkness level four appears.
6. If toasting a frozen bread product, press the Defrost button. It will illuminate when activated. (Learn more about the Defrost mode as described above under Options.)
7. If desired, turn the Time/Slices knob to adjust the number of slices, as needed. Turn right to increase the number of slices and left to decrease the number. The number may be set as low as one slice or as high as six slices.
8. If desired, turn the Temp/Shade knob to select the level of darkness. Choose between a minimum of level one (for lightest browning) and a maximum of level nine (for the darkest browning).
9. Insert the bagels or muffins, cut sides facing up, into the oven directly on the oven rack.
10. Press the Start/Cancel button.
11. The oven control will show the toasting time remaining as it begins to count down.

Recommended Toasting Times and Temperatures

As you become familiar with your convection oven, we want to share a few suggestions for toasting bagels and English muffins. You can experiment to identify your preferred toasting setting.

Bagel Chart

Type of Bread Product	Setting (for medium browning)
Bagels (sliced)	Shade level four
English muffins (sliced)	Shade level seven

PIZZA



How it Works

When choosing Pizza mode, the top and bottom heating elements cycle on and off maintaining a constant temperature to bake pizza from above and below.

When to Use This Setting

Choose for baking either fresh or frozen pizzas. This button sets the convection oven for a baking

mode designed specifically for pizzas.

- **Preheat** - Yes
- **Rack Position** - Middle
- **Recommended Baking Pans** - Metal baking pans are suggested, such as pizza pans and small baking sheets. For a crisper crust, bake directly on the oven rack.

Options

Defrost and Convection modes

Choose Defrost if you are cooking a frozen pizza. Defrost is customized to bake a crisper pizza. Additional cook time may be required by the user.

Choose Convection if you want the convection fan to operate, creating more even baking results. The convection fan circulates warm air in the oven, which browns foods and creates a golden crust on baked items.

Setting the Controls for Pizza

1. Make sure the convection oven is properly plugged in and ready for operation. (See **Electrical Requirements** on **page 4** for further instructions.)
2. Place the oven rack in the middle position. The middle rack position has a safety hook to prevent the rack from falling out when it is removed. To remove the rack, tilt upward and pull forward. The reverse process is needed to reinstall the rack.
3. When powered on, default settings for the convection oven are displayed. The oven is set to Bake for 10 minutes at 350 °F with the convection function activated.
4. Press the Mode button to select the Pizza setting.
5. If desired, activate or deactivate the Defrost or Convection options by pressing the corresponding buttons. They illuminate when activated. (Learn more about Defrost and Convection modes as described above under Options.)
6. The default setting for pizza is set to Bake for 20 minutes at 400 °F. Defrost is the default setting.
7. Turn the Time/Slices knob to select the desired cooking time. Turn right to increase the time and left to decrease the time. The time may be set in one minute increments up to a maximum of two hours.
8. Turn the Temp/Shade knob to select the desired oven temperature. Turn right to increase the temperature and left to decrease it. The temperature may be set in 5 degree increments from a minimum of 150 °F to a maximum of 450 °F.
9. Press the Start/Cancel button. The oven begins preheating. Preheating will flash on the display until the selected oven temperature is reached.
10. Once preheated, the oven will chime, the desired temperature will illuminate on the display, and the timer will begin counting down.
11. Insert the pizza into the oven on a pizza pan, baking sheet or directly on the oven rack.

Recommended Baking Times and Temperatures

Times and temperatures are the same as for traditional ovens. Simply follow the pizza package directions and homemade pizza recipe instructions for recommended baking times and temperatures. Refer to our baking chart (shown next page) for general guidelines.

Pizza Chart

Food	Approx. Time	Approx. Temperature
12-inch frozen pizza	20 minutes	400 °F
12-inch fresh pizza	15 to 18 minutes	400 °F
Frozen single serve deep dish pizza	20 to 25 minutes	375 °F
Frozen single serve thin crust pizza	13 to 15 minutes	375 °F
Frozen French bread pizza	20 to 25 minutes	400 °F
Frozen individual pizza calzone	40 minutes	425 °F
Refrigerated fresh unbaked pizza	12 to 18 minutes	425 °F
Refrigerated unbaked calzone	25 to 30 minutes	375 °F

COOKIES



How it Works

When choosing Cookies mode, the top and bottom heating elements cycle on and off, maintaining a constant temperature to bake cookies from above and below.

When to Use This Setting

Choose for baking cookie dough. This mode sets the convection oven with the ideal baking cycle for your favorite cookies.

- **Preheat** - Yes
- **Rack Position** - Middle

- **Recommended Baking Pans** – Metal baking pans are suggested. For baking cookies, a small baking sheet works well, or the 9 x 10-inch nonstick baking pan provided with your Calphalon convection oven.

Options

Defrost and Convection modes

Choose Defrost if you are baking frozen foods. The Defrost setting is customized to gently thaw frozen cookies and extend cooking time. Additional cook time may be required by the user.

Choose Convection if you want cookies that have a crisp, golden crust on the outside.

The convection fan circulates warm air in the oven, which beautifully browns baked goods. Using convection helps create more even baking results.

Setting the Controls for Cookies

1. Make sure the convection oven is properly plugged in and ready for operation. (See **Electrical Requirements** on **page 4** for further instructions.)
2. Place the oven rack in the middle position. The middle rack position has a safety hook to prevent the rack from falling out when it is removed. To remove the rack, tilt upward and pull forward. The reverse process is needed to reinstall the rack.
3. When powered on, default settings for the convection oven are displayed. The oven is set to Bake for 10 minutes at 350°F with the convection function activated.
4. Press the Mode button to select the Cookies setting.
5. The default setting for cookies is set to convection Bake for 11 minutes at 350°F.
6. If desired, activate or deactivate the Defrost or Convection options by pressing the corresponding buttons. They illuminate when activated. (Learn more about Defrost and Convection modes as described above under Options.) When Defrost is selected, three additional minutes are added to the cooking time.
7. Turn the Time/Slices knob to select the desired cooking time. Turn right to increase the time and left to decrease the time. The time may be set in one minute increments up to a maximum of two hours.

8. Turn the Temp/Shade knob to select the desired oven temperature. Turn right to increase the temperature and left to decrease it. The temperature may be set in 5 degree increments from a minimum of 150° F to a maximum of 450° F.
9. Press the Start/Cancel button. The oven begins preheating. Preheating will flash on the display until the selected oven temperature is reached.
10. Once preheated, the oven will chime, the desired temperature will illuminate on the display, and the timer will begin counting down.
11. Place cookie dough on the baking sheet, allowing space for cookies to spread while baking.
12. Insert the baking sheet into the oven.

Recommended Baking Times and Temperatures

Times and temperatures are the same as for traditional ovens. Simply follow the package directions for purchased cookie dough and recipe instructions for homemade cookie dough. Refer to our baking chart (shown below) for general guidelines.

Cookie Chart

Food	Approx. Time	Approx. Temperature
Pre-packaged cookies	11 minutes	350° F
Drop cookies	8 minutes	375° F
Shaped cookies	7 minutes	375° F
Cut out cookies	7 minutes	375° F
Filled cookies	10 minutes	375° F
Brownies	18 to 25 minutes	350° F

CLEANING AND CARE

WARNING

Unplug convection oven before cleaning. Failure to do so may result in risk of serious injury and electric shock.

Before Cleaning

1. **CANCEL** – Press the Start/Cancel button if convection oven is still in operation.
2. **UNPLUG** – Carefully unplug the convection oven's power cord from the electrical outlet by firmly grasping the plug.
3. **COOL** – Let the convection oven, oven rack, and baking pan cool completely before attempting any cleaning. The crumb tray will be hot after operating.

Cleaning the Crumb Tray

- Locate the crumb tray in the front of the convection oven at the base of oven door.
- Using the handle, pull out the cooled crumb tray and discard the crumbs.
- If needed, wash the crumb tray. Wash by hand using warm water and mild detergent. Rinse and dry with a soft cloth.
- Make sure the crumb tray is completely dry before placing it back in the convection oven.
- Reinsert the crumb tray, making sure to push it in completely.

CAUTION

Do not operate the convection oven without the crumb tray in place. Do not cover crumb tray or any part of the oven with metal foil. This will cause overheating of the oven.

Cleaning the Convection Oven

- The 9 x 10-inch baking pan provided with the convection oven is dishwasher safe.
- Wash the oven rack and crumb tray by hand using warm water and mild detergent. Rinse and dry with a soft cloth.
- Use a damp cloth to wipe the inside and outside of the oven with a clean, damp cloth.
- If desired, polish the body of the convection oven with cleansers specifically designed for stainless steel surfaces. Avoid spraying cleaners directly into the convection oven. Apply the cleaners on a towel prior to wiping the unit.
- Do not immerse the convection oven in water during cleaning.
- Do not use abrasive cleaning products or cleansers, since they may scratch the surface of the convection oven.
- Metal utensils will damage the nonstick coating. Use only nonmetal, temperature resistant utensils such as wood or silicone.

CAUTION

Do not clean the convection oven with metal scouring pads. Pieces can break off the pad and touch electrical parts, creating a risk of electric shock.

STORAGE

Store the convection oven upright on a clean, dry level surface. Do not store anything on top of the convection oven.

Do not store any materials, other than manufacturers recommended accessories, in this oven when not in use.

Always clean the convection oven by removing all crumbs prior to storing.

FREQUENTLY ASKED QUESTIONS

I hear a slight clicking noise while the oven is operating. Is this a malfunction? No, the convection oven is equipped with real time temperature feedback. The LCD will display the current oven temperature during the pre-heating phase in order to communicate the pre-heat progress of the oven. Once the oven temperature stabilizes to the desired set point, the oven will no longer display real time temperature feedback. The temperature control of the oven is designed to be highly accurate in order to achieve optimal cooking results. As a result, a slight clicking noise will be heard periodically indicating that the oven is maintaining accurate temperature control.

I am pressing the Convection button, but it is not illuminating. The convection oven chimes three times, but the convection mode doesn't seem to activate. What am I doing wrong? You may be trying to select Convection while using the Broil, Toast or Bagel modes. The convection mode is not available (or needed) during these settings. Simply continue setting the controls without the convection mode selected.

The same is true of trying to select the Defrost option while using Broil or Bake. This option is not available. So, if you press the Defrost button when setting the oven to Bake or Broil, it will chime three times to alert you that this setting is not available.

While setting the controls for a cooking cycle, it appears the display went dark. Is this a malfunction? If the convection oven is allowed to sit inactive for 3 minutes, it will go into Sleep mode. This could happen if you set the cooking cycle but forget to touch the flashing Start/Cancel button to begin cooking. To wake up the control panel and reset it, touch any button.

Why do some types of bread brown more than others when using the same shade selection? This could be due to a several factors. The moisture, texture, temperature, sugar content and thickness of the slices can all affect levels of browning.

In general, fresher breads have more moisture and brown slower than breads that are a bit drier and are closer to their expiration date. Room temperature bread will brown quicker than refrigerated or frozen bread. And, thin, light textured breads brown quicker than densely textured, thick sliced breads.

While waiting for the oven to preheat for toasting a bagel, I noticed that after a few minutes, the oven automatically shut off. Why did this happen? Actually, preheating is not required for the Toast and Bagel modes. So, insert your bagel in the oven before pressing the Start/Cancel button, since the toasting cycle begins immediately.

I noticed that the heating elements inside my oven keep going on and off. Is this a sign that it may be malfunctioning? It is normal for the heating elements to cycle on an off to maintain a selected temperature in the oven cavity.

My food isn't completely warm. Why did this happen? For best results, insert food immediately after preheating is complete to allow for optimal results.

WARRANTY

Register your Convection Oven - It's Easy!

Please register your product to ensure that we have the correct information in our system for any warranty inquiries. **Retain the original sales receipt. Without registering your product or having the original sales receipt, we will consider the warranty start date to be the date of manufacture.**

Taking a few moments to register your product greatly expedites warranty inquiries and helps us continue to develop new products and services that make your culinary experience even better. Please contact **Calphalon Customer Service** for complete details.

Limited One Year Warranty

Calphalon will repair or replace any convection oven found defective in material or workmanship within one year of the original purchase with the original sales receipt. This warranty applies when the convection oven is put to normal household use and is operated and cared for according to the instructions. This excludes damage from misuse or abuse, such as improper cleaning, neglect, accident, alteration, fire, theft, or use in a commercial establishment. Minor imperfections, surface markings as a result of shipping, and slight color variation are normal. This warranty excludes all incidental and consequential damages, except in those states that do not allow the exclusion or limitation of these damages. Without an original sales receipt or having registered your product with Calphalon, the warranty start date will be considered the date of manufacture. This warranty gives you specific legal rights, and you may have other rights that vary from state to state.

Customer Service

We at Calphalon want to hear from you. If you have a question, comment, or a recommendation that will help us help you, please contact us via our web site, phone, fax or mailing address.

Please do not return the product to the store. Please contact us directly with questions or comments about your convection oven. Thank you!

Web site

www.calphalon.com

Write Us

Calphalon Customer Service

PO Box 583

Toledo, Ohio 43697-0583

(Please, DO NOT send returns to this address)

Toll Free Phone

1-800-809-7267

(Monday-Friday 8:00am – 5:00pm EST)

Fax

419-666-2859

RECIPES

Citrus Shrimp and Artichokes

Serves 3 to 4 as an appetizer

Ingredients

Marinade:

- ½ cup fresh lime juice
- ¼ cup orange marmalade
- 3 cloves fresh garlic, minced
- 2 tablespoons fresh orange zest
- ¼ cup chopped cilantro
- ¼ cup garlic infused olive oil
- 2 tablespoons soy sauce
- ½ teaspoon dried red chili flakes
- Zest of 1 lime

Shrimp:

- 1½ pounds large (10-12 ct.) shrimp, peeled and deveined with tails left intact
- 1 (15 ounce) can artichoke hearts, well drained and cut in half
- 2 teaspoons olive oil
- Sprigs of cilantro for garnish
- 6 small bamboo skewers soaked in lemon water

Method:

Combine the marinade ingredients in a medium bowl.

Place the shrimp and artichokes into a half gallon storage bag. Add all but ⅓ cup of marinade to the shrimp. The reserved marinade can be used as a dipping sauce when serving. The shrimp should marinate for at least 1 and no more than 2 hours. After marinating, thread the shrimp and artichokes onto the skewers, 3 shrimp and 3 artichoke halves per skewer.

Position the oven rack in the middle slot with the rack oriented upwards. Preheat your Calphalon XL Convection Oven for **5 minutes on Broil**. Place the skewered shrimp into the convection oven and Broil the shrimp for 2 to 3 minutes on each side. Serve with dipping sauce.

Open Face Roast Beef and Cheddar Melt

Serves 1

Ingredients: (per sandwich)

- 1 slice of marble rye bread
- 1 teaspoon olive oil
- 2 teaspoons horseradish mayonnaise
- 6 ounces lean, medium-rare roasted beef, sliced thin
- 1 cup (4 ounces) coarsely grated cheddar cheese

Method

Brush one side of the bread with the olive oil. Place the oil brushed side of the bread down on the work surface. Spread the side facing up with the mayonnaise. Place the roasted beef in loose layers over the mayonnaise and top with the grated cheddar. Place the sandwich on a baking pan. Position the oven rack in the **lower slot** with the rack oriented upwards. Set your Calphalon XL Convection Oven to **Toast** on **“Medium”**. Place the sandwich in the oven and toast until the cheese is bubbling and golden.

Asian Style Roast Chicken

Serves 2 to 4

Ingredients:

1 (3 to 3¼ pounds) whole chicken
Salt, to taste
½ medium onion, cut into ½-inch cubes
1 medium lemon, cut into ½-inch cubes
2 (3-inch) cinnamon sticks, broken
3 large cloves garlic, crushed
2 teaspoons five spice powder
1 teaspoon salt
1 tablespoon vegetable oil
2 tablespoons fresh lemon juice
Zest of 1 large lemon
2 cloves garlic, minced
1 tablespoon hoisin sauce
1 tablespoon soy sauce
1 teaspoon toasted sesame seed oil

Method:

Preheat your Calphalon XL Convection Oven to **350 degrees**. Choose convection if you want the convection fan to operate, creating more even baking results.

Rinse the chicken inside and out and pat dry. Sprinkle some salt into the cavity of the chicken. Fill the cavity of the chicken with the onion, lemon, cinnamon and garlic.

In a medium bowl, combine remaining ingredients. Drizzle about ⅓ of the mixture into the cavity of the chicken. Pour the remaining mixture over the exterior of the chicken, brushing or rubbing to make sure the entire surface is covered. Place on the broiler pan and cook for 1 hour and 10 minutes to 1 hour and 20 minutes on the Bake setting or 55 to 60 minutes on the Bake setting with convection fan activated. Pierce one of the thighs with a meat thermometer to test for doneness. The thermometer should register 160 to 165° F or cook until the juices run clear when you pierce the thigh with a knife. Remove from the oven and cool for 15 minutes prior to carving. Serve with stir-fried or steamed vegetables and long grain brown rice.

Dried Cherry and White Chocolate Blondies

Makes 12 to 15 squares

Ingredients:

Butter for interior of 9x13-inch baking pan
1 cup dried, tart cherries
8 tablespoons Cognac
1 cup lightly packed light brown sugar
1 cup unsalted butter, softened
2 large eggs
¾ cup dark corn syrup
2 tablespoons Cognac
2 cups all purpose flour
½ teaspoon baking powder
¼ teaspoon salt
1 cup white chocolate morsels

Method:

Position the oven rack in the **lower slot** with the rack oriented upwards. Preheat your Calphalon XL Convection Oven to **350 degrees**. Butter the interior of a shallow 9x13-inch pan. Place the 8 tablespoons Cognac into a small sauce pan or butter warmer. Add the cherries and simmer until most of the Cognac has been absorbed. Reserve.

Mix the brown sugar, butter, eggs, corn syrup and 2 tablespoons Cognac in a large bowl.

In another bowl combine the flour, baking powder and salt. Add the flour mixture to the corn syrup mixture. Add the cherries and white chocolate morsels. Combine thoroughly. Pour the batter into the prepared pan. Bake for 25 minutes or until the batter forms a light crust and just begins to set. Remove from the oven and cool for a few minutes. Cut into squares and serve.

Serving suggestion – White Chocolate Drizzle:

½ cup white chocolate morsels
2 teaspoons whipping cream
Bring the cream to a simmer in a small sauce pan or butter warmer. Whisk in the morsels. Drizzle over the top of the blondie before cutting. (Make sure the blondie is completely cooled before drizzling).

Calphalon® 

© 2011