Chapter 6: Installation

This chapter describes how to install and test the hardware for a PMP/PTP 450 platform link. It contains the following topics:

- [ODU variants and mounting bracket options](#) on page 6-2 provides details of six different bracket options, including the type of ODU and range of pole diameters supported by each option.
- [Mount the ODU, LPU and surge suppressor](#) on page 6-3 describes how to mount and ground an integrated or connectorized ODU, how to mount and ground the top LPU.
- [Installing the copper Cat5e Ethernet interface](#) on page 6-17 describes how to install the copper Cat5e power over Ethernet interface from the ODU to the PSU.
- [Installing external antennas to a connectorized ODU](#) on page 6-21 describes how to install external antennas for a connectorized ODU.
- [Installing ODU](#) on page 6-56 describes how to install PTP and PMP ODU radios.
- [Installing the AC Power Injector](#) on page 6-61 describes how to install a power supply unit for the PMP/PTP 450 platform, either the AC Power Injector.
- [Supplemental installation information](#) on page 6-64 contains detailed installation procedures that are not included in the above topics, such as how to strip cables, create grounding points and weatherproof connectors.



Note

These instructions assume that LPUs are being installed from the PMP/PTP 450 platform LPU and grounding kit (Cambium part number C000065L007). If the installation does not require LPUs, adapt these instructions as appropriate.

If LPUs are being installed, only use the five black-capped EMC cable glands supplied in the LPU and grounding kit. The silver-capped cable glands supplied in the ODU kits must only be used in PMP/PTP 450 platform installations which do not require LPUs.

ODU variants and mounting bracket options

Mounting bracket– PMP/PTP 450i

The PMP/PTP 450i series supports below mentioned mounting bracket option:

Table 81 PMP/PTP 450i ODU mounting bracket part numbers

Cambium description	Cambium part number
Mounting bracket – low profile adjustable	N000045L002A

The low profile bracket provides elevation adjustment with the PMP/PTP 450i Integrated ODUs of +10° to –5° or +5° to –10°. A larger adjustment range is available using the standard integrated mounting bracket. The connectorized mounting bracket does not provide elevation adjustment.

Mounting bracket– PMP 450 900 MHz SM

The PMP 450i 900 MHz SM has special mounting bracket option. The PMP 450i 900 MHz AP mounting procedure is the same as the other 450i radios. The 900 450 SM has a different mounting bracket which is supplied along with yagi antenna.

Mount the ODU, LPU and surge suppressor

To install the ODU and top LPU, use the following procedures:

- [Attach ground cables to the ODU](#) on page 6-3
- [Mount the ODU on the mast](#) on page 6-6
- [Mount the top LPU](#) on page 6-9
- [Mount the Surge Suppressor](#) on page 6-9

Attach ground cables to the ODU

PMP 450m Series – AP

- 1 Fasten an AWG 10 (or 6mm²) copper ground cable to each ODU grounding point using the M6 (small) lugs.
- 2 Tighten the Ground post screws.
- 3 Securely connect the copper wires to the grounding system (Protective Earth) and the LPU or Gigabit Ethernet Surge Suppressor according to applicable regulations.

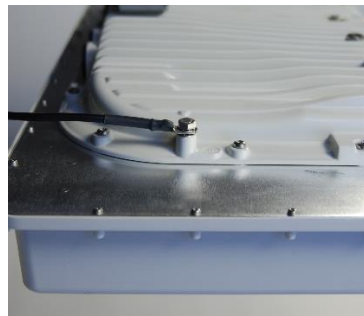
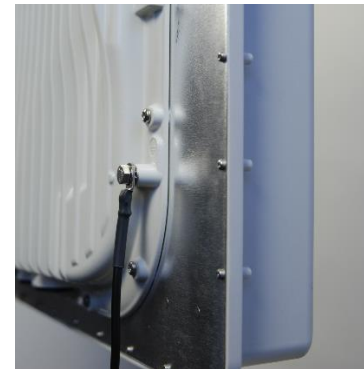
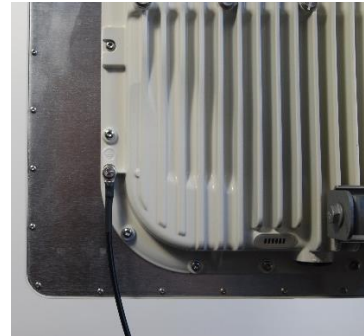

PMP/PTP 450i Series – AP/SM/BH, PMP 450 3GHz Ruggedized SM

- 1 Fasten an AWG 10 (or 6mm²) copper ground cable to each ODU grounding point using the M6 (small) lugs.



- 2 Tighten the Ground post screws.



- 3 Securely connect the copper wires to the grounding system (Protective Earth) and the LPU or Gigabit Ethernet Surge Suppressor according to applicable regulations.

PMP 450 AP

- 1 Fasten an AWG 10 (or 6mm²) copper ground cable to each ODU grounding point using the M6 (small) lugs

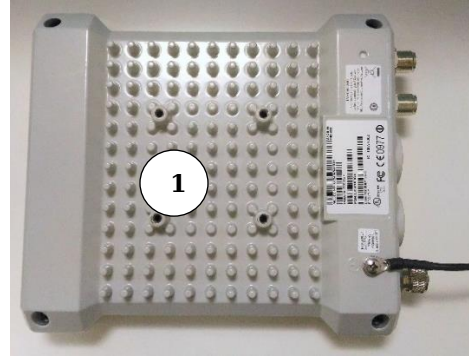

- 2 Tighten the Ground post locking nut in the copper wire

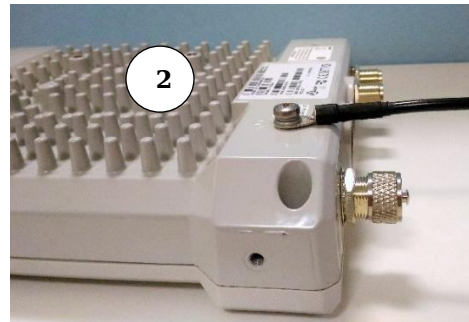

- 3 Securely connect the copper wire to the grounding system (Protective Earth) according to applicable regulations.

PMP 450 SM

- 1 Fasten an AWG 10 (or 6mm²) copper ground cable to each ODU grounding point using the M6 (small) lugs

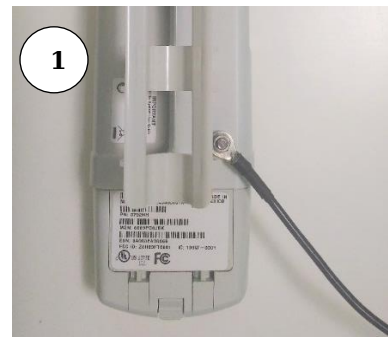

- 2 Tighten the Ground post locking nut in the copper wire



- 3 Securely connect the copper wire to the grounding system (Protective Earth) according to applicable regulations.

The grounding point on PMP 450 900 MHz SM is different from 2.4, 3.5/3.65 and 5 GHz PMP 450 SMs as shown in [Figure 47](#).

Figure 47 PMP 450 900 MHz SM grounding

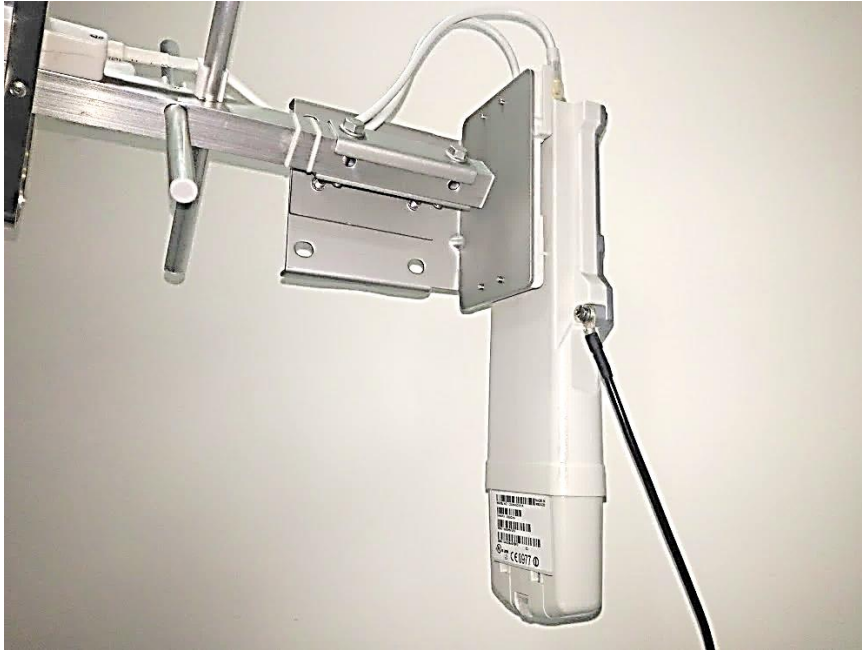

Mount the ODU on the mast

PMP 450m Series – AP

- 1 See - [PMP 450m Series – AP](#) on page 6-49 for Installation for an integrated ODU
- 2 Remove the rear bracket strap from upper and lower brackets of ODU
- 3 Attach the upper and lower bracket of ODU to the mount point by closing the rear strap around the pole
- 4 Tighten the four serrated flange M10 nuts on upper and lower rear strap using a 17 mm spanner wrench. These must be tightened evenly on the pole to avoid jumping/stripping threads

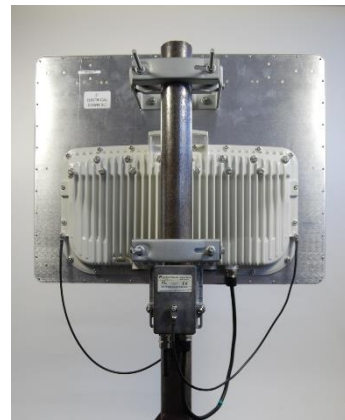

PMP/PTP 450i Series – AP/SM/BH, PMP 450 3 GHz Ruggedized SM



Caution

Do not reverse the bracket clamp, as this arrangement may lead to failure of the assembly. Do not over-tighten the bolts as this may lead to failure of the assembly.

- 1 Fix the mounting plate to the back of the ODU using the four bolts, and spring and plain washers provided. Tighten the bolts.
- 2 Attach the bracket body to the mounting plate using the M8 bolt, spring and plain washers.
- 3 Hoist the ODU to the mounting position
- 4 Attach the bracket body to the pole using the bracket clamp, M8 bolts, and spring and plain washers.
- 5 Adjust the elevation and azimuth to achieve visual alignment.



PMP 450 AP

- 1 Using an 8mm nut driver, attach the pole mount's AP housing bracket to the unit using the 4 M5 x 16mm bolts included with the AP.
- 2 Using the included (depending on pole diameter):
 - M8 x 70mm hex cap bolts (2 quantity)
 - or
 - M8 x 40mm hex cap bolts (2 quantity)
 - and
 - M8 flat washers (2 quantity)
 - M8 coil washers (2 quantity)

Attach the mounting bracket to the pole/mast. The mounting bracket is designed to attach to poles with diameters in the range of 2 in. (50mm) to 3in. (75mm).

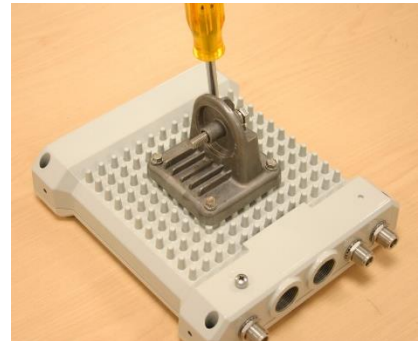

- 3 Complete the AP mounting assembly by attaching the included:

- 8mm hex cap bolt (one quantity)

Through the AP's attached mounting bracket and pole mount. At this time the AP may be adjusted to the desired position and tightened with a 1/2 inch spanner wrench to 11 lb/ft (14Nm).



PMP 450 SM (except PMP 450 SM - 900 MHz)

- 1 Use stainless steel hose clamps for the attachment.
- 2 Attach the mounting bracket to the structure. Tighten the locking nut.

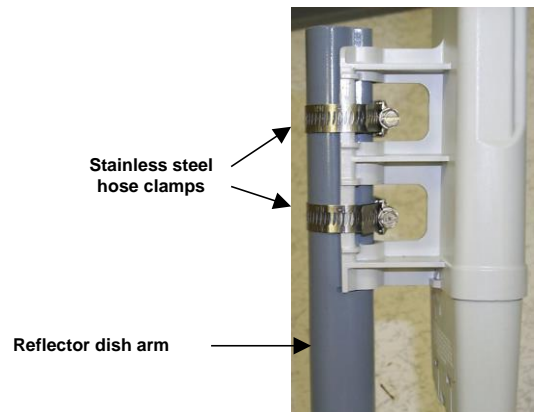

PMP 450 900 MHz SM (connectorized)

The PMP 450 900 MHz connectorized SM mounting procedure is different from other radios. It does not get directly mounted on pole.

- 1 Align the 900 MHz SM to E bracket of Yagi antenna
- 2 Slide the radio towards right to lock on the antenna

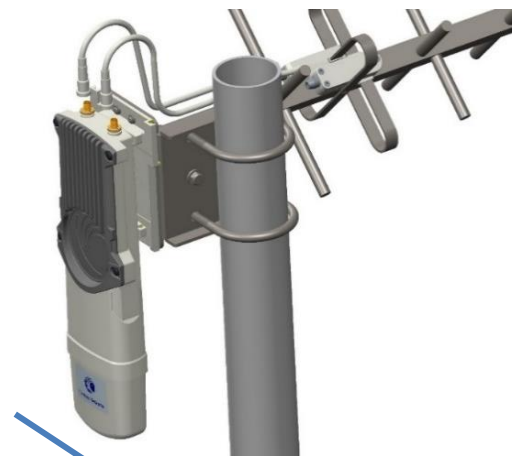

Slide towards right to lock

Mount the top LPU

- 1 For separate LPU mounting, use the U-bolt bracket from the LPU kit to mount the top LPU on the pole below the ODU. Tighten to a torque setting of 7.0 Nm (5.2 lb ft).

Please refer *Gigabit LPU and Grounding Kit Installation Guide* for more details.



Mount the Surge Suppressor

PMP/PTP 450i Series

Gigabit Ethernet Surge Suppressors are installed at both ends of the drop cable. One within 600 mm (24") space of and under the ODU. The other located within 600 mm (24") space of the building entry point.

Quick procedure:

The quick procedure for the Surge Suppressor for PMP/PTP 450i Series mounting is as follows:

- 1 Ground using the terminal on the back of the units. Use the supplied Tubular Lug and 6 mm² (10 AWG) stranded cable, max length 600 mm (24").
 - I. Waterproof the cable lug with heat shrink sleeving.
 - II. Secure the Cable assembly to the unit using the supplied screw and washer.
- 2 Mounting the Gigabit Ethernet Surge Suppressor on wall or pole



- 3 Connecting the two CAT5e cables to the Gigabit Ethernet Surge Suppressor

- 4 Slide the end cap over the bottom of the Gigabit Surge Suppressor, ensuring it clicks firmly in place



Please refer *Gigabit Ethernet Surge Suppressor Installation Guide* for more details.

Figure 48 Gigabit Surge Suppressor



PMP/PTP 450 Series

The PMP/PTP 450 Series uses 600SSH Surge Suppressor. The inside of the surge suppressor is shown in [Figure 49](#).



Caution

The PMP 450 900 MHz SM is based off the 450 platform, be sure to use a 600SS to protect this radio type.

Figure 49 600SSH Surge Suppressor – inside

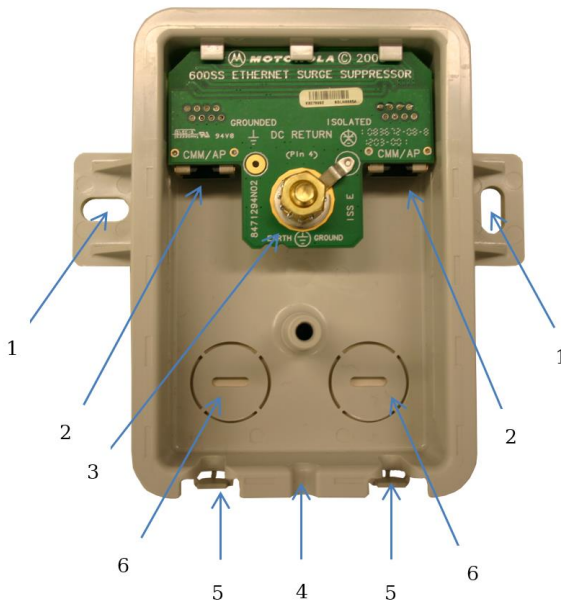

Key to Callouts 600SSH

- 1 Holes—for mounting the Surge Suppressor to a flat surface (such as an outside wall). The distance between centers is 4.25 inches (108 mm).
- 2 RJ-45 connectors—One side (neither side is better than the other for this purpose) connects to the product (AP, SM, or cluster management module). The other connects to the AC adaptor's Ethernet connector.
- 3 Ground post and washer—use heavy gauge (10 AWG or 6 mm²) copper wire for connection. Refer to local electrical codes for exact specifications.
- 4 Ground Cable Opening—route the 10 AWG (6 mm²) ground cable through this opening.
- 5 CAT-5 Cable Knockouts—route the two CAT-5 cables through these openings, or alternatively through the Conduit Knockouts.
- 6 Conduit Knockouts—on the back of the case, near the bottom. Available for installations where cable is routed through building conduit.



Note

The 600SSH surge suppressor is shipped in the “isolated” position (pin 4 isolated by 68V from protective earth). If packet error issues occur over the Ethernet link (verify by pinging the device through the 600SSH), configure the 600SSH to “grounded” position (by moving the 600SSH switch from “isolated” to “ground”) to avoid ground loops that may be present in the system.

The mounting procedure for the Surge Suppressor for PMP/PTP 450 Series is as follows:

- 1 Remove the cover of the 600SSH Surge Suppressor.
- 2 With the cable openings facing downward, mount the 600SSH to the *outside* of the subscriber premises, as close to the point where the Ethernet cable penetrates the residence or building as possible, and as close to the grounding system (Protective Earth) as possible.
- 3 Wrap an AWG 10 (or 6mm²) copper wire around the Ground post of the 600SSH.
- 4 Tighten the Ground post locking nut in the 600SSH onto the copper wire.
- 5 Securely connect the copper wire to the grounding system (Protective Earth) according to applicable regulations.
- 6 Using diagonal cutters or long nose pliers, remove the knockouts that cover the cable openings to the 600SSH.
- 7 Pack both of the surge suppressor Ethernet jacks with dielectric grease.
- 8 Wrap an AWG 10 (or 6mm²) copper wire around the Ground post of the 600SSH.
- 9 Tighten the Ground post locking nut in the 600SSH onto the copper wire.
- 10 Securely connect the copper wire to the grounding system (Protective Earth) according to applicable regulations.
- 11 Using diagonal cutters or long nose pliers, remove the knockouts that cover the cable openings to the 600SSH.
- 12 Pack both of the surge suppressor Ethernet jacks with dielectric grease.
- 13 Wrap a splice loop in the loose end of the Ethernet cable from the SM.
- 14 Connect that cable to one of the Ethernet jacks.
- 15 Connect an Ethernet cable to the other Ethernet jack of the 600SSH and to the power adapter.
- 16 Replace the cover of the 600SSH.

General protection installation

To adequately protect a 450 platform installation, both ground bonding and transient voltage surge suppression are required.

Basic requirements

The following basic protection requirements must be implemented:

- ODU must be in 'Zone B' (see [Lightning protection zones](#) on page 3-9).
- ODU must be grounded to the supporting structure.
- A surge suppression unit must be installed on the outside of the building.

- The distance between the ODU and Gigabit Surge Suppressor should be kept to a minimum.
- The drop cable must not be laid alongside a lightning air terminal.
- All grounding cables must be a minimum size of 10 mm² csa (8AWG), preferably 16 mm² csa (6AWG), or 25 mm² csa (4AWG).

Grounding cable requirements

When routing, fastening and connecting grounding cables, the following requirements must be implemented:

- Grounding conductors must be run as short, straight, and smoothly as possible, with the fewest possible number of bends and curves.
- Grounding cables must not be installed with drip loops.
- All bends must have a minimum radius of 203 mm (8 in) and a minimum angle of 90° (Figure 50). A diagonal run is preferable to a bend, even though it does not follow the contour or run parallel to the supporting structure.
- All bends, curves and connections must be routed towards the grounding electrode system, ground rod, or ground bar.
- Grounding conductors must be securely fastened.
- Braided grounding conductors must not be used.
- Approved bonding techniques must be used for the connection of dissimilar metals.

Figure 50 Grounding cable minimum bend radius and angle

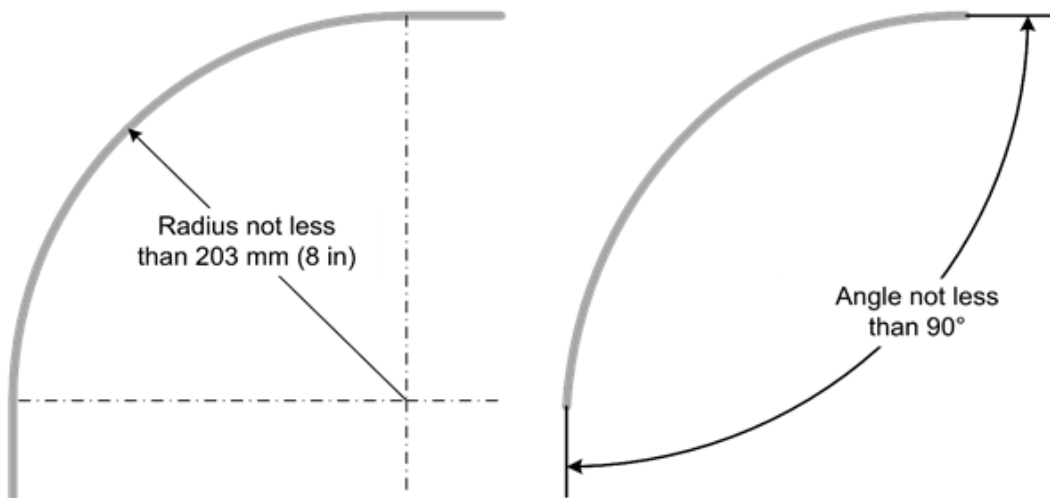

Caution

Do not attach grounding cables to the ODU mounting bracket bolts, as this arrangement will not provide full protection.

Protection requirements for a mast or tower installation

If the ODU is to be mounted on a metal tower or mast, then in addition to the general protection requirements (above), the following requirements must be observed:

- The equipment must be lower than the top of the tower or its lightning air terminal.
- The metal tower or mast must be correctly grounded.

Schematic examples of mast or tower installations are shown in [Figure 51](#).

Figure 51 Grounding and lightning protection on mast or tower

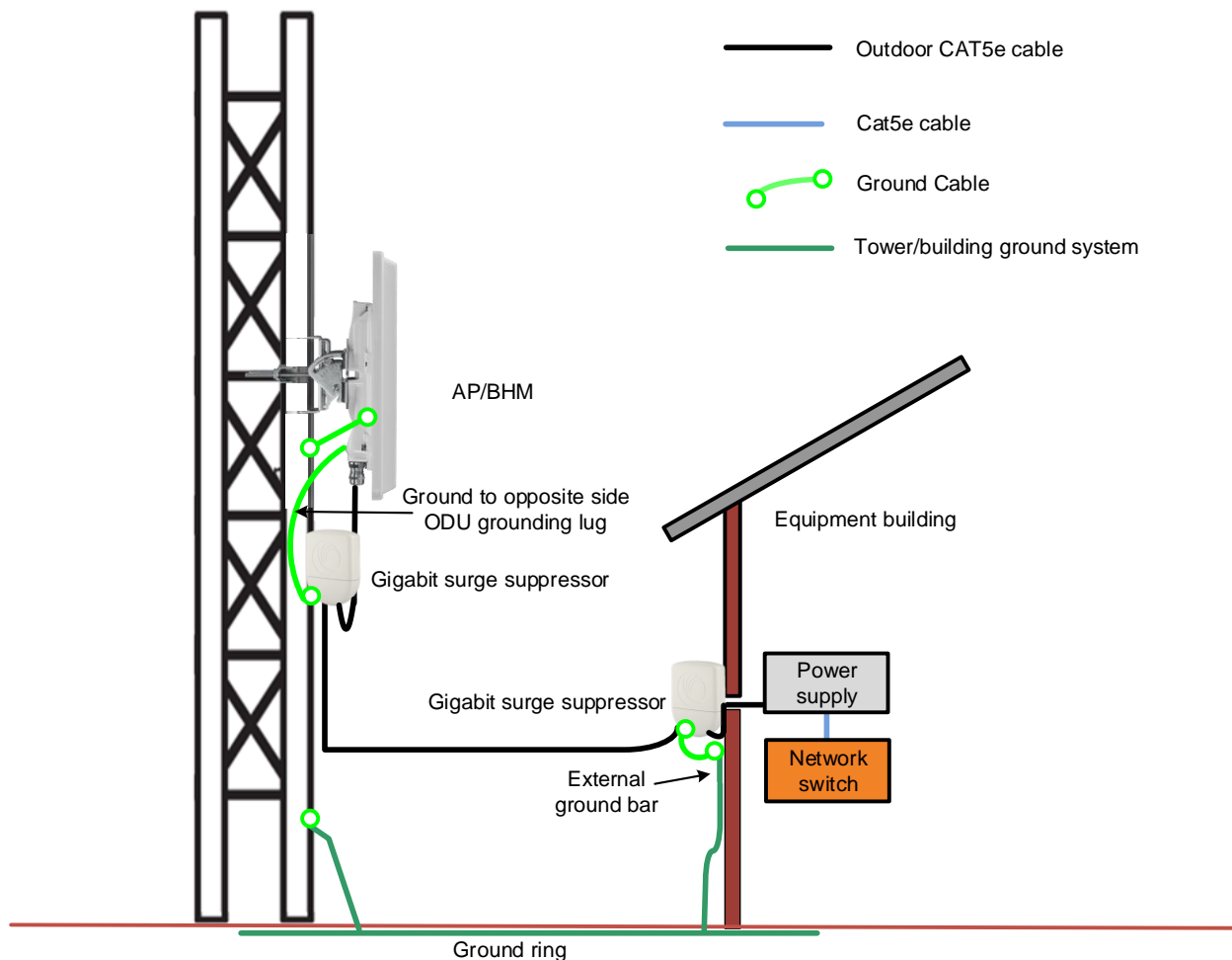

Protection requirements for a wall installation

If the ODU is to be mounted on the wall of a building, then in addition to the general protection requirements (above), the following requirements must be observed:

- The equipment must be lower than the top of the building or its lightning air terminal.
- The building must be correctly grounded.

Schematic examples of wall installations are shown in [Figure 52](#).

Figure 52 Grounding and lightning protection on wall

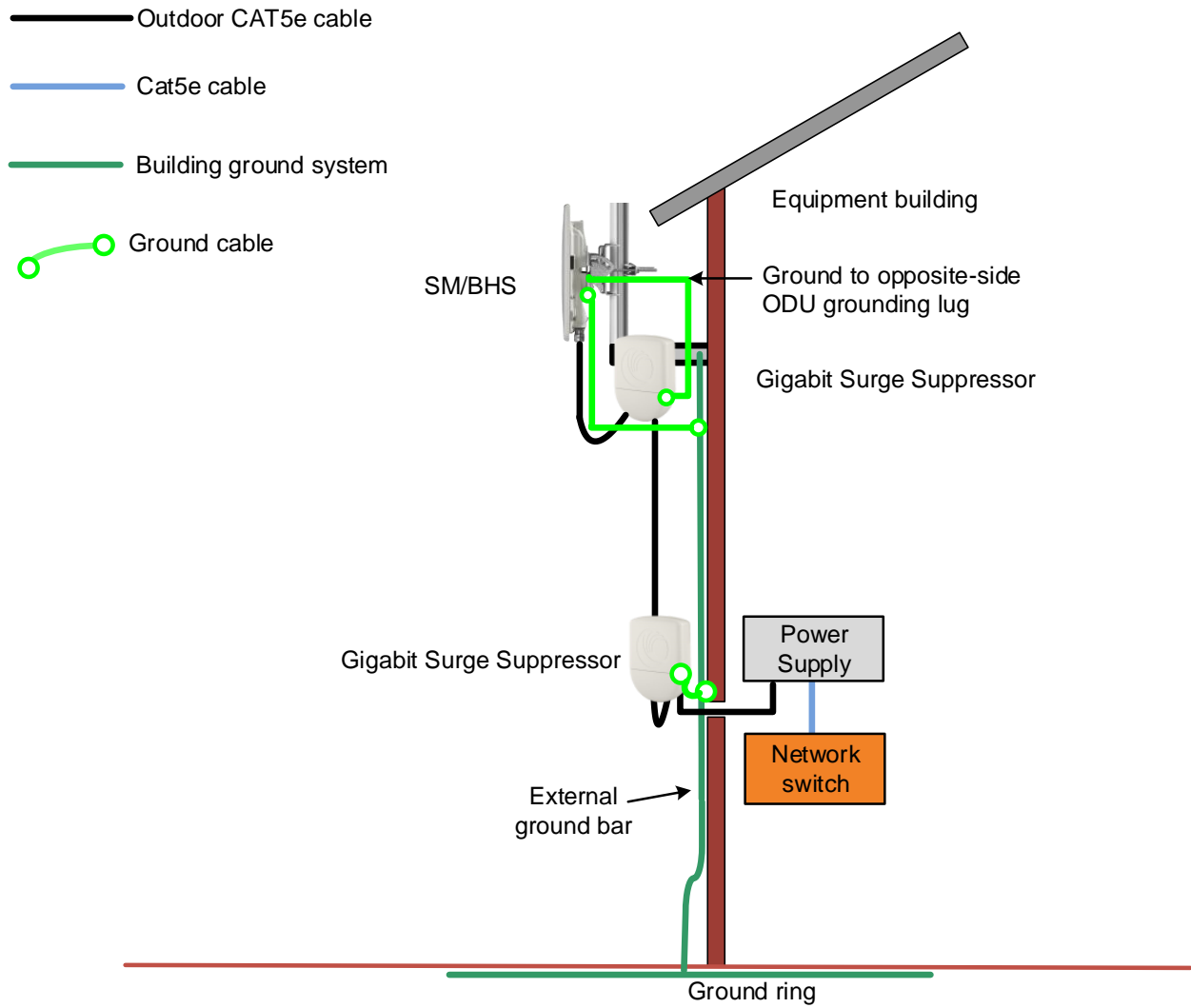

Protection requirements on a multifloor building

If the ODU is to be mounted on a high rise building, it is likely that cable entry is at roof level (Figure 32) and the equipment room is several floors below. The following additional requirements must be observed:

- The ODU must be below the lightning terminals and finials.
- A grounding conductor must be installed around the roof perimeter to form the main roof perimeter lightning protection ring.
- Air terminals are typically installed along the length of the main roof perimeter lightning protection ring typically every 6.1m (20ft).
- The main roof perimeter lightning protection ring must contain at least two down conductors connected to the grounding electrode system. The down conductors should be physically separated from one another, as far as practical.

Figure 53 Grounding and lightning protection on building

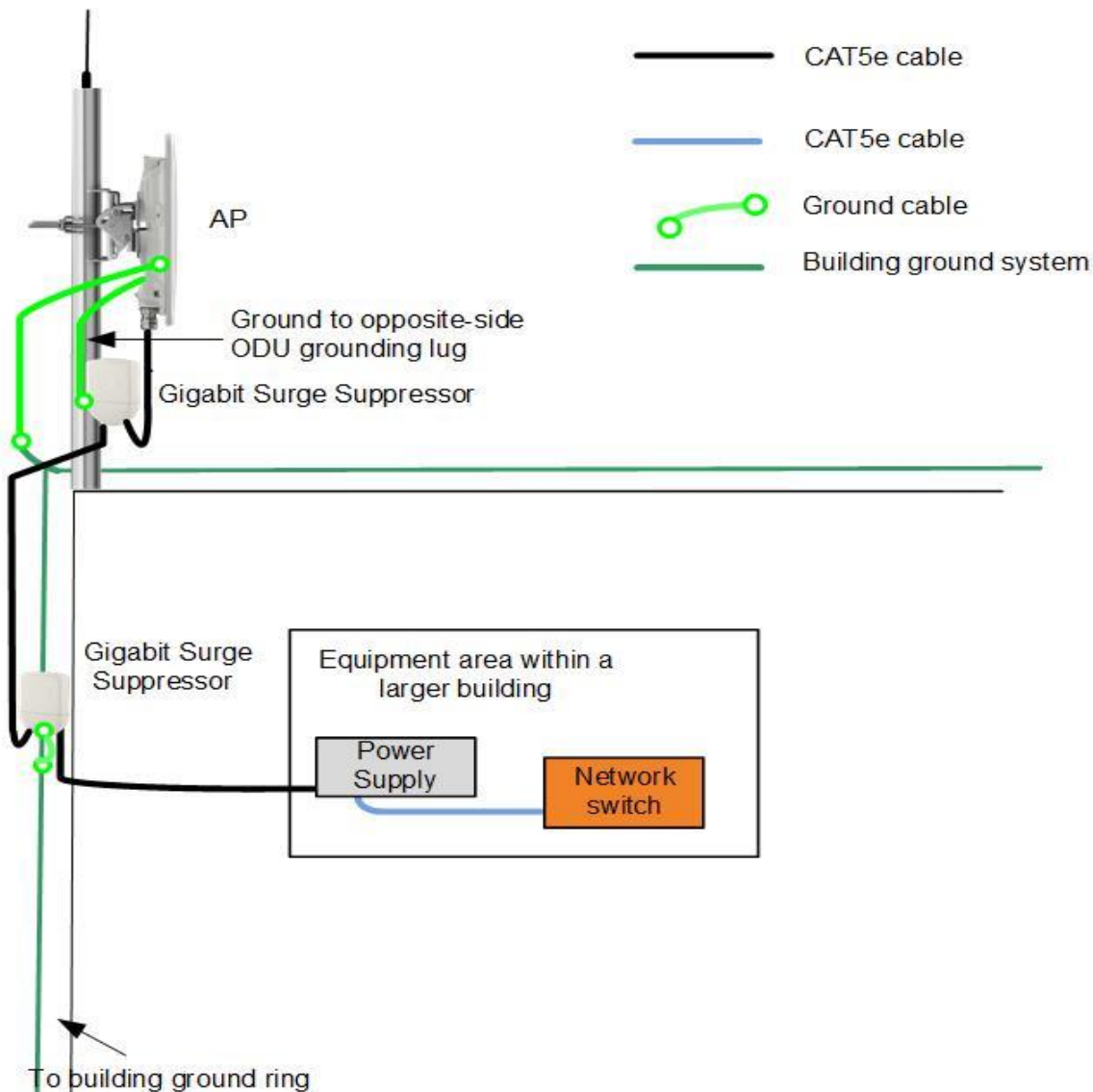

Installing the copper Cat5e Ethernet interface

To install the copper Cat5e Ethernet interface, use the following procedures:

- [Install the main drop cable](#) on page 6-17
 - [Install the bottom LPU to PSU drop cable](#) on page 6-19
 - [Installing external antennas to a connectorized ODU](#) on page 6-21
-

**Caution**

To avoid damage to the installation, do not connect or disconnect the drop cable when power is applied to the PSU or network terminating equipment.

**Caution**

Always use Cat5e cable that is gel-filled and shielded with copper-plated steel. Alternative types of Cat5e cable are not supported by Cambium Networks. Cambium Networks supply this cable (Cambium part numbers WB3175 and WB3176), RJ45 connectors (Cambium part number WB3177) and a crimp tool (Cambium part number WB3211). The LPU and grounding kit contains a 600 mm length of this cable.

Install the main drop cable

**Warning**

The metal screen of the drop cable is very sharp and may cause personal injury.

- ALWAYS wear cut-resistant gloves (check the label to ensure they are cut resistant).
 - ALWAYS wear protective eyewear.
 - ALWAYS use a rotary blade tool to strip the cable (DO NOT use a bladed knife).
-

**Warning**

Failure to obey the following precautions may result in injury or death:

- Use the proper hoisting grip for the cable being installed. If the wrong hoisting grip is used, slippage or insufficient gripping strength will result.
 - Do not reuse hoisting grips. Used grips may have lost elasticity, stretched, or become weakened. Reusing a grip can cause the cable to slip, break, or fall.
 - The minimum requirement is one hoisting grip for each 60 m (200 ft) of cable.
-

Cut to length and fit hoisting grips

- 1 Cut the main drop cable to length from the top LPU to the bottom LPU.
- 2 Slide one or more hoisting grips onto the top end of the drop cable.
- 3 Secure the hoisting grip to the cable using a special tool, as recommended by the manufacturer.

Terminate with RJ45 connectors



Caution

Check that the crimp tool matches the RJ45 connector, otherwise the cable or connector may be damaged.

- 1 Strip the cable outer sheath and fit the RJ45 connector load bar.
- 2 Fit the RJ45 connector housing as shown. To ensure there is effective strain relief, locate the cable inner sheath under the connector housing tang.

Table 82 RJ45 connector and cable color code

Pin	Color (Supplied cable)	Color (Conventional)	Pins on plug face
1	Light Orange	White/Orange	
2	Orange	Orange	
3	Light Green	White/Green	
4	Blue	Blue	
5	Light Blue	White/Blue	
6	Green	Green	
7	Light Brown	White/Brown	
8	Brown	Brown	

Figure 54 RJ45 cable



Install the bottom LPU to PSU drop cable

Install the bottom LPU

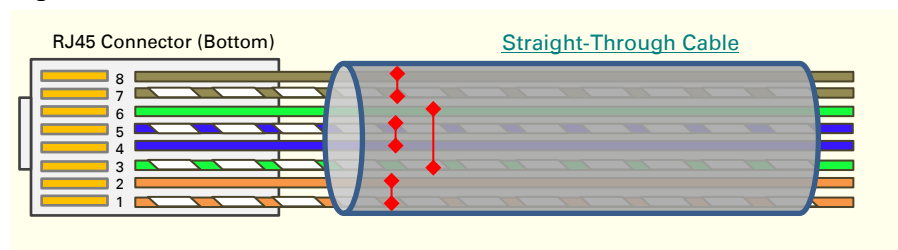
Install the bottom LPU, ground it, and connect it to the main drop cable.

- 1 Select a mounting point for the bottom LPU within 600 mm (24 in) of the building entry point. Mount the LPU vertically with cable glands facing downwards.

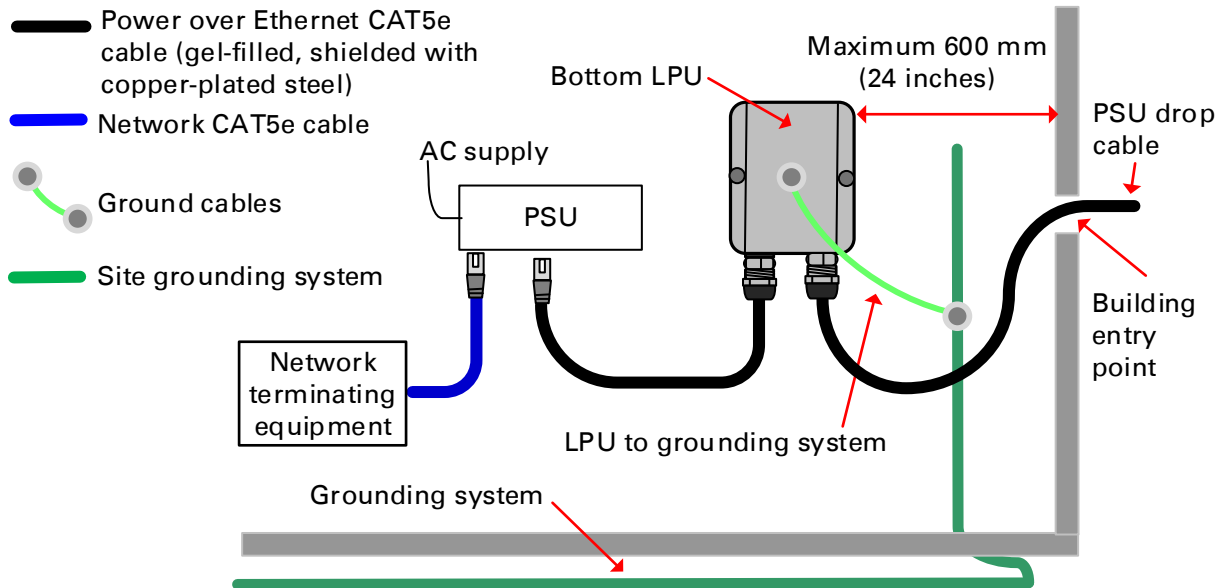

- 2 Connect the main drop cable to the bottom LPU.
- 3 Fasten one ground cable to the bottom LPU using the M6 (small) lug. Tighten both nuts to a torque of 5 Nm (3.9 lb ft):

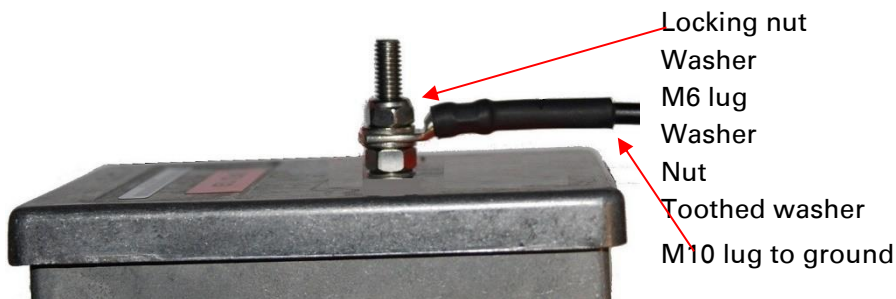

- 4 Select a building grounding point near the LPU bracket. Remove paint from the surface and apply anti-oxidant compound. Fasten the LPU ground cable using the M10 (large) lug.

Install the LPU to PSU drop cable

Use this procedure to terminate the bottom LPU to PSU drop cable with RJ45 connectors at both ends, and with a cable gland at the LPU end.



Warning

The metal screen of the drop cable is very sharp and may cause personal injury. ALWAYS wear cut-resistant gloves (check the label to ensure they are cut resistant). ALWAYS wear protective eyewear. ALWAYS use a rotary blade tool to strip the cable, not a bladed knife.



Caution

Check that the crimp tool matches the RJ45 connector, otherwise the cable or connector may be damaged.

- 1 Cut the drop cable to the length required from bottom LPU to PSU.
- 2 **At the LPU end only:**
 - Fit one cable gland and one RJ45 connector by following the procedure [Terminate with RJ45 connectors](#) on page 6-18.
 - Connect this cable and gland to the bottom LPU.
- 3 **At the PSU end only:** Do not fit a cable gland. Strip the cable outer sheath and fit the RJ45 connector load bar. Fit the RJ45 connector housing. To ensure there is effective strain relief, locate the cable inner sheath under the connector housing tang:

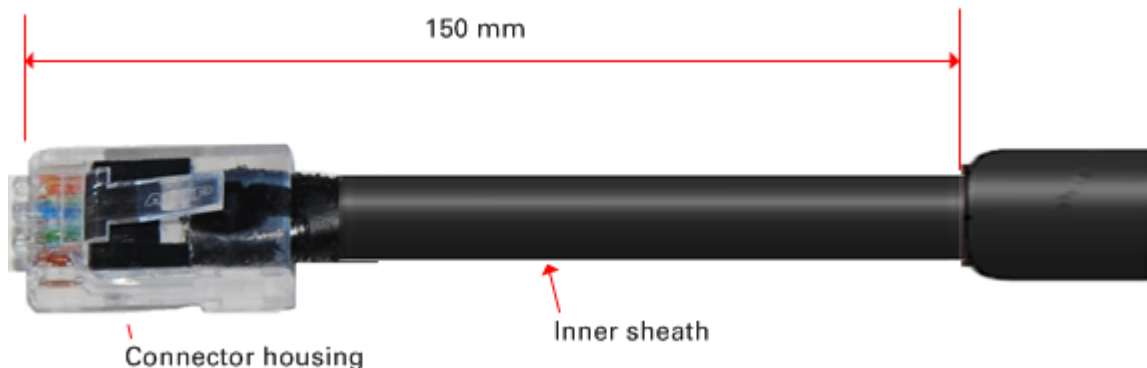

Installing external antennas to a connectorized ODU

PMP 450i Series

To mount and connect an external antenna to the connectorized ODU, proceed as follows:

- 1 Mount the antenna(s) according to manufacturer's instructions.
- 2 Connect the ODU A and B interfaces to the antenna(s) with RF cable of type LMR-400 (Cambium part numbers 30010194001 and 30010195001) and N type connectors (Cambium part number 09010091001). Tighten the N type connectors to a torque setting of 1.7 Nm (1.3 lb ft).
- 3 If the ODU is mounted indoors, install lightning arrestors at the building entry point:
- 4 Form drip loops near the lower ends of the antenna cables. These ensure that water is not channeled towards the connectors.
- 5 If the ODU is mounted outdoors, weatherproof the N type connectors (when antenna alignment is complete) using PVC tape and self-amalgamating rubber tape.
- 6 Weatherproof the antenna connectors in the same way (unless the antenna manufacturer specifies a different method).

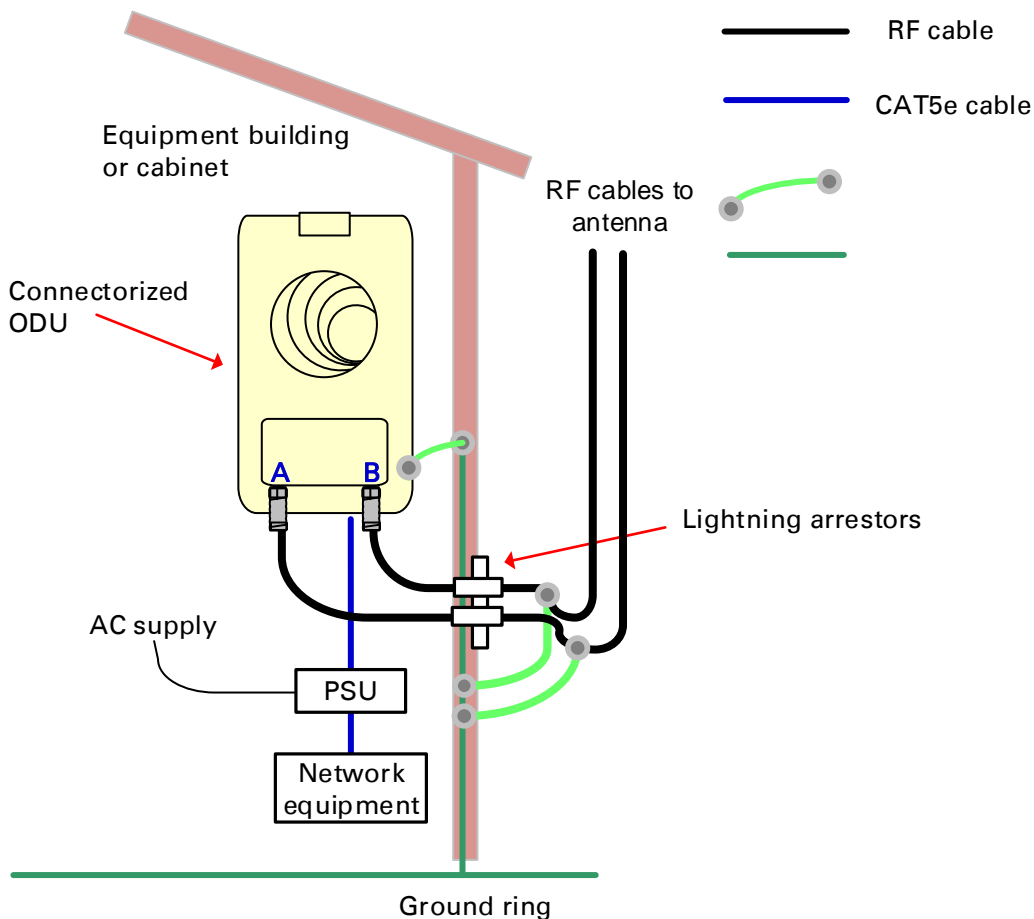

- 7 Ground the antenna cables to the supporting structure within 0.3 meters (1 foot) of the ODU and antennas using the Cambium grounding kit (part number 01010419001):

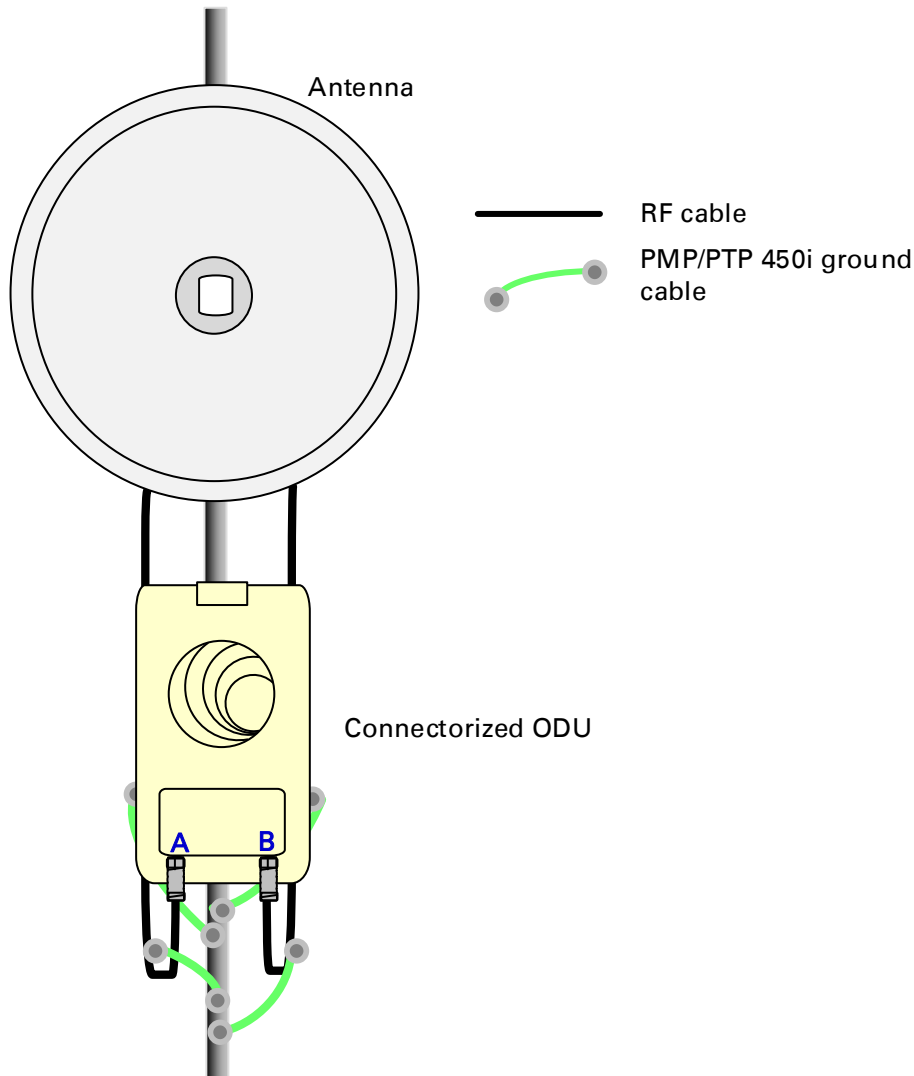

- 8 Fix the antenna cables to the supporting structure using site approved methods. Ensure that no undue strain is placed on the ODU or antenna connectors. Ensure that the cables do not flap in the wind, as flapping cables are prone to damage and induce unwanted vibrations in the supporting structure.

**Note**

A video on weatherproofing procedure can be found at:

<https://www.youtube.com/watch?v=a-twPfCVq4A>

Assembling the PMP 450i 5.x GHz AP sector antenna and attaching to the radio

To assemble a PMP 450i Series AP antenna, perform the following steps.



Note

Cambium recommends to assemble the antenna, attach the AP and cabling, and to seal the RF connections before installing the unit at the deployment site.

- 1 Inventory the parts to ensure that you have them all before you begin. The full set of parts is shown below.

Figure 55 AP antenna parts



- 2 Remove top plate from the antenna as shown in [Figure 56](#).

Figure 56 Antenna top plate

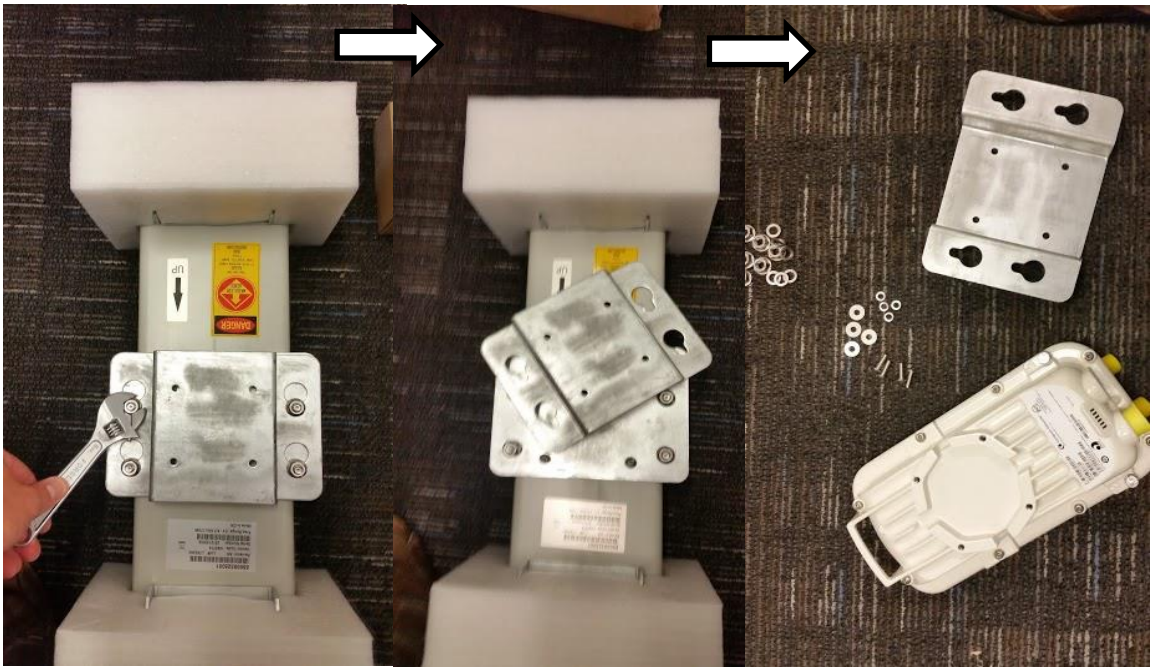

- 3 Attach the antenna plate to the AP as shown in [Figure 57](#).



Note

Please use the four “thin neck” M6 bolts and split washers provided with the connectorized units rather than the ones provided in the antenna kit.

Figure 57 Attaching antenna plate to the AP

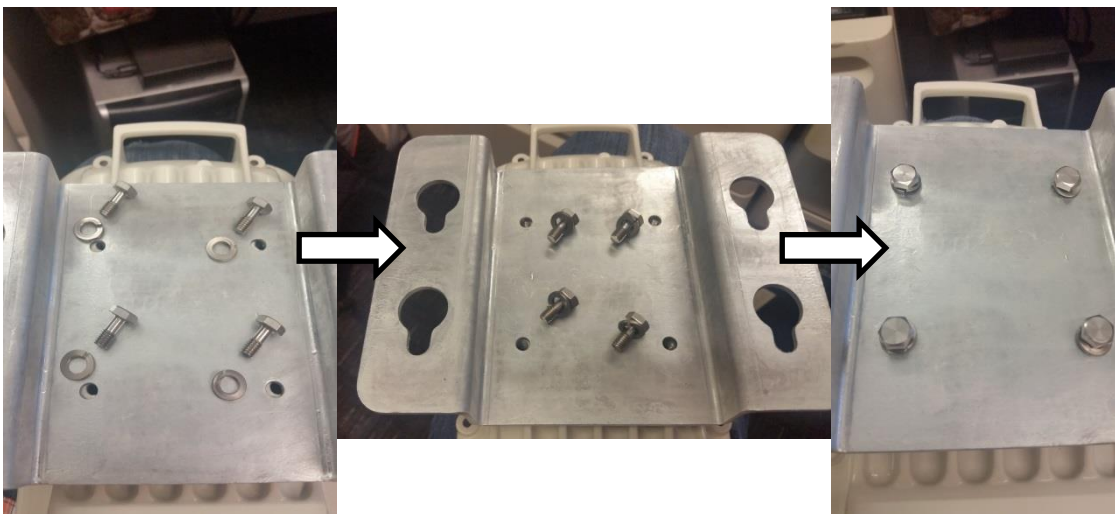

- 4 Attach the plate mounted AP to the antenna and tighten the (4) serrated flange nuts using a spanner wrench

Figure 58 Attaching the plate



- 5 Connect the port A of AP to vertical and port B of AP to horizontal polarization interfaces of the antenna with RF cable. Tighten the N type connectors to a torque setting of 1.7 Nm (1.3 lb ft).

Figure 59 Connect the port A and B to the PMP 450i AP

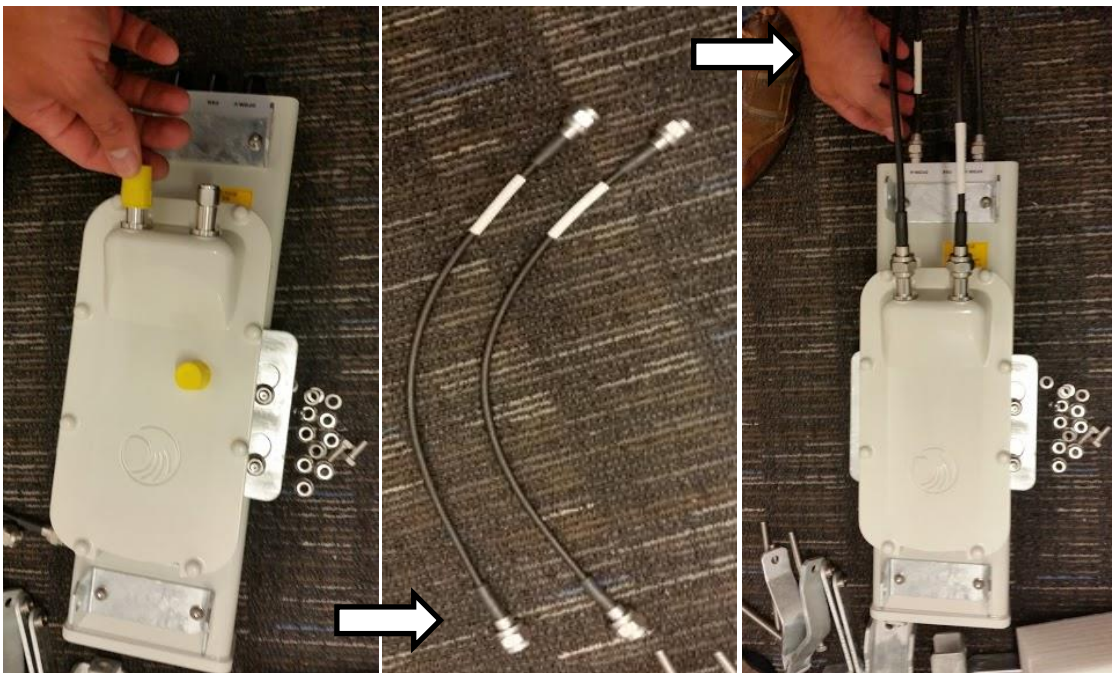

- 6 Assemble the upper bracket by attaching the (2) 7" hex bolts to the bracket using (2) serrated flange nuts

Figure 60 AP antenna upper bracket assembly

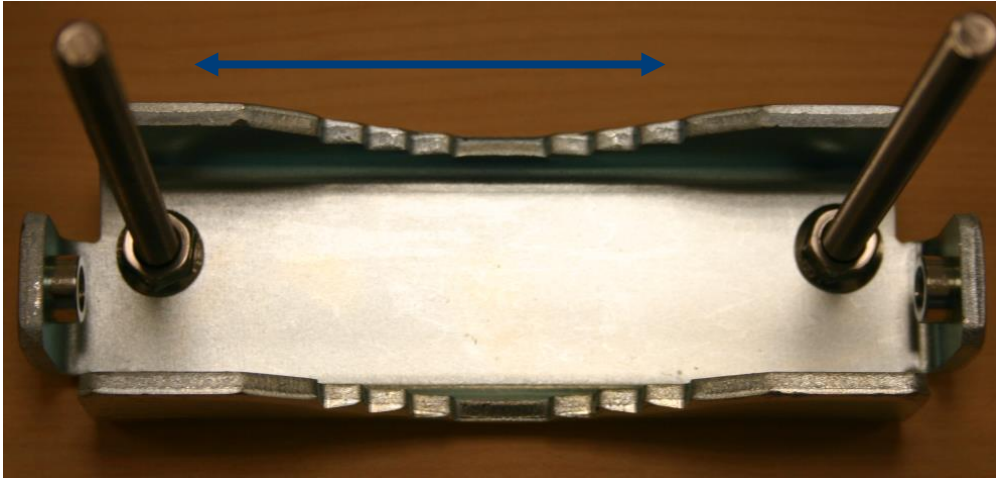

- 7 Attach the upper bracket to the adjustment arms using (2) hex bolts, (2) flat washers and (2) lock washers. Feed the bolt through the lock washer then flat washer, then thread the bolt into the upper bracket's threaded receptacle.

Figure 61 AP antenna upper bracket attached to upper adjustment arms



- 8** Attach the rear strap to the upper bracket using (2) serrated flange nuts and (1) retaining bracket. Do not tighten the nuts now.

Figure 62 Rear strap connected to upper AP antenna bracket



- 9** Attach the entire upper bracket to the antenna using (2) hex bolts, (2) flat washers and (2) lock washers. Feed the bolt through the lock washer then flat washer, then thread the bolt into the upper bracket's threaded receptacle.

Figure 63 Assembled upper bracket connected to AP antenna



- 10** Begin assembling the lower bracket by attaching the (2) 7" hex bolts to the bracket using (2) serrated flange nuts

Figure 64 AP Antenna Lower Bracket Assembly



- 11** Attach the rear strap to the bracket using (2) serrated flange nuts and (1) retaining bracket. Do not tighten the nuts now.

Attach the entire lower bracket to the antenna using (2) hex bolts, (2) flat washers and (2) lock washers.

Figure 65 Lower bracket attached to AP antenna



Figure 66 Completed AP and antenna assembly



PMP 450 Series

Assembling the PMP 450 AP antenna

To assemble a PMP 450 Series AP antenna, perform the following steps.



Note

Cambium recommends to assemble the antenna, attach the AP and cabling, and to seal the RF connections before installing the unit at the deployment site.

- 1 Inventory the parts to ensure that you have them all before you begin. The full set of parts is shown below.

Figure 67 PMP 450 AP antenna parts

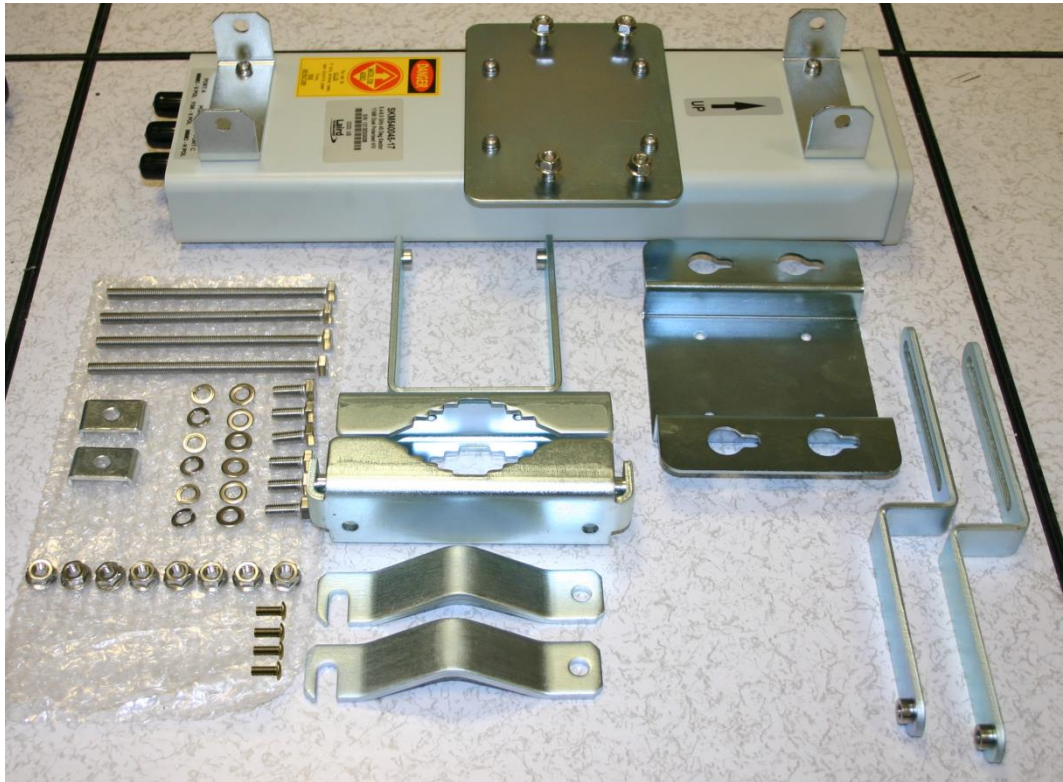

- 2 Begin assembling the upper bracket by attaching the (2) 7" hex bolts to the bracket using (2) serrated flange nuts

Figure 68 AP antenna upper bracket assembly



- 3 Attach the upper bracket to the adjustment arms using (2) hex bolts, (2) flat washers and (2) lock washers. Feed the bolt through the lock washer then flat washer, then thread the bolt into the upper bracket's threaded receptacle.

Figure 69 AP antenna upper bracket attached to upper adjustment arms



- 4 Attach the rear strap to the upper bracket using (2) serrated flange nuts and (1) retaining bracket. Do not tighten the nuts now.

Figure 70 Rear strap connected to upper AP antenna bracket

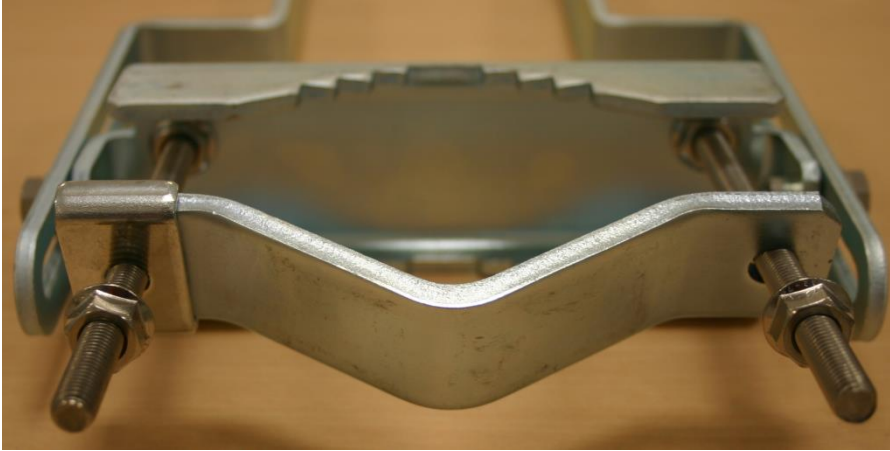

- 5 Attach the entire upper bracket to the antenna using (2) hex bolts, (2) flat washers and (2) lock washers. Feed the bolt through the lock washer then flat washer, then thread the bolt into the upper bracket's threaded receptacle.

Figure 71 Assembled upper bracket connected to AP antenna



- 6 Begin assembling the lower bracket by attaching the (2) 7" hex bolts to the bracket using (2) serrated flange nuts

Figure 72 AP Antenna Lower Bracket Assembly



- 7 Attach the rear strap to the bracket using (2) serrated flange nuts and (1) retaining bracket. Do not tighten the nuts now.

Attach the entire lower bracket to the antenna using (2) hex bolts, (2) flat washers and (2) lock washers.

Figure 73 Lower bracket attached to AP antenna



Attaching the PMP 450 AP to the antenna

To attach a PMP 450 Series AP to the antenna, perform the following steps.

**Note**

Use shielded cable for all infrastructure connections associated with APs, SMs, and CMMs. The environment that these modules operate in often has significant unknown or varying RF energy. Operator experience consistently indicates that the additional cost of shielded cables is more than compensated by predictable operation and reduced costs for troubleshooting and support.

- 1 Attach the included bracket to the rear of the AP using the (4) M5 x 7mm bolts

Figure 74 Attaching bracket to the rear of the AP



- 2 Attach the AP to the antenna by sliding the bracket onto the bolts and tighten the (4) serrated flange nuts using a 13 mm spanner wrench.

Figure 75 Lower bracket attached to AP antenna



**Note**

If using a non-standard antenna, do not cover the equilibrium membrane vent located on the back of the unit.

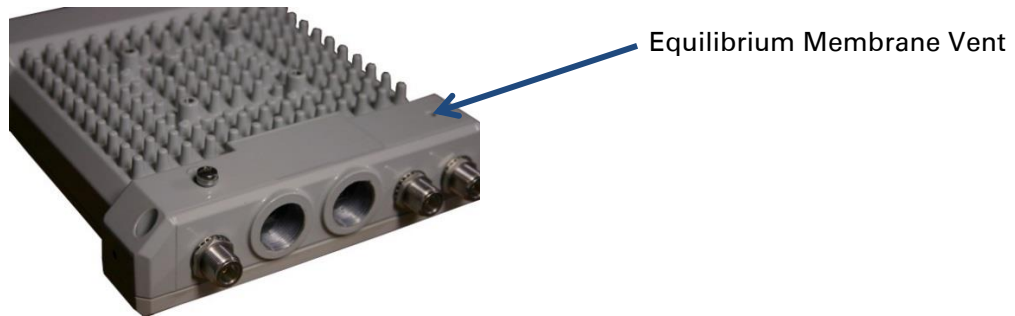

Figure 76 Mounted PMP 450 AP and antenna assembly, viewed from back and back



Attaching the PMP 450 platform AP and antenna to the mount point

- 1 Attach the upper bracket of the antenna to the mount point by closing the rear strap around the pole and tightening the (2) serrated flange nuts using a 13mm spanner wrench. These must be tightened evenly on the pole to avoid jumping/stripping threads.

Figure 77 Attaching the AP antenna upper bracket to the pole



- 2 Attach the lower bracket of the antenna to the mount point by closing the rear strap around the pole and tightening the (2) serrated flange nuts using a 13mm spanner wrench. These must be tightened evenly on the pole to avoid jumping/stripping threads.

Figure 78 Attaching the AP antenna lower bracket to the pole



- 3 Use a local map, compass, and/or GPS device as needed to determine the direction that one or more APs require to each cover the 90° sector.

4 Choose the best mounting location for your particular application.

**Note**

Use the embedded spectrum analyzer or a commercial analyzer to evaluate the frequencies present in various locations. OFDM APs need not be mounted next to each other. They can be distributed throughout a given site. However, the 90° offset must be maintained. If you want to collocate these APs with PMP 100 Series APs of the 5.4-GHz frequency band range, plan to allow at least 25 MHz of separation between their center channels.

5 Secure a ground strap to the ground lug on the back of the AP.

6 Secure the ground strap to the pole, tower, or other trusted ground.

7 The bracket of the standard antenna has provision for measured down tilt. The recommended practice is to use one of the many radio analysis and mapping tools or on-line tools to calculate down tilt based on antenna height above the service area.

The proper angle of tilt can be calculated as a factor of both the difference in elevation and the distance that the link spans. Even in this case, a plumb line and a protractor can be helpful to ensure the proper tilt. This tilt is typically minimal.

The number of degrees to offset (from vertical) the mounting hardware leg of the support tube is equal to the angle of elevation from the lower module to the higher module (<B in the example provided in Figure 43).

Figure 79 Variables for calculating angle of elevation (and depression)

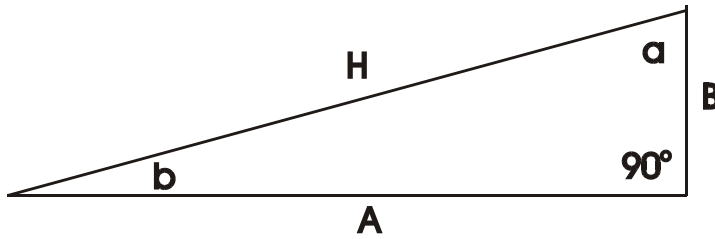

Where:	Is:	
	b	angle of elevation
	B	vertical difference in elevation
	A	horizontal distance between modules

To use metric units to find the angle of elevation, use the following formula:

$$\tan b = \frac{B}{1000A}$$

Where:	Is:	
	B	expressed in meters
	A	expressed in kilometers

To use English standard units to find the angle of elevation, use the following formula:

$$\tan b = \frac{B}{5280A}$$

Where:	Is:	
	B	expressed in feet
	A	expressed in miles

The angle of depression from the higher module is identical to the angle of elevation from the lower module.

- 8 Connect the coax cables to the antenna and to the AP
- 9 Weatherproof the connector on the coax cables (see section [Attaching and weatherproofing an N type connector](#) on page 6-68).

PMP 450i Series 900 MHz AP

Mounting of PMP 450i 900 MHz AP

- 1 Inventory the parts to ensure that you have them all before you begin. The full set of parts is shown in [Figure 81](#).

Figure 80 PMP 450i 900 MHz AP antenna unbox view

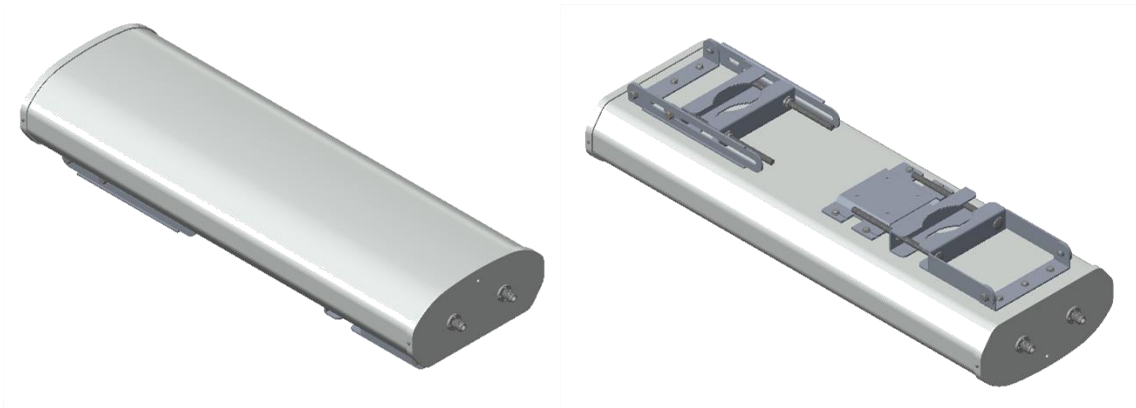
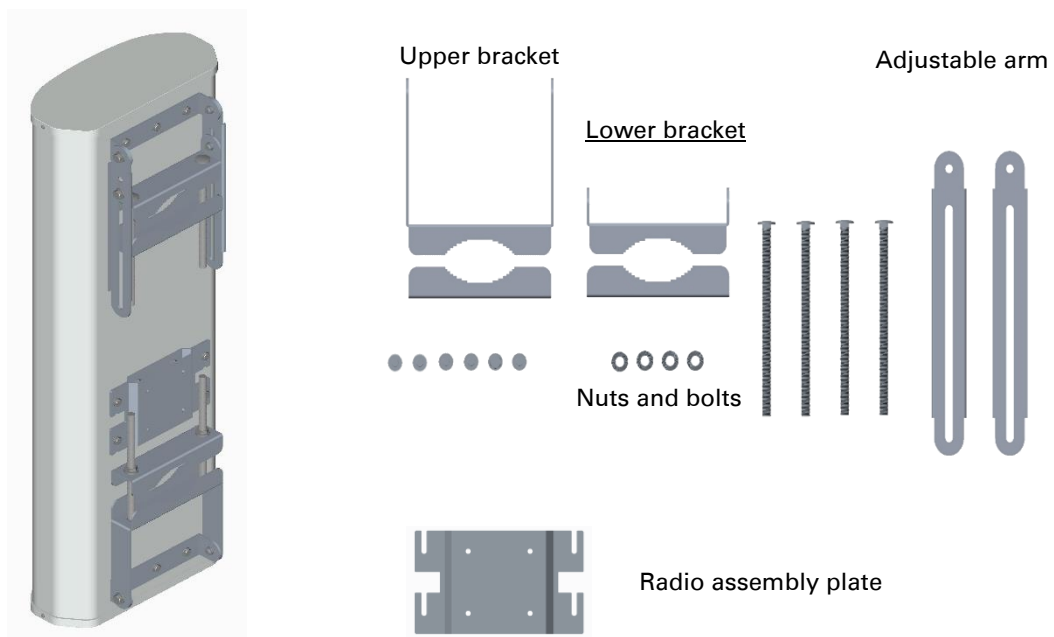
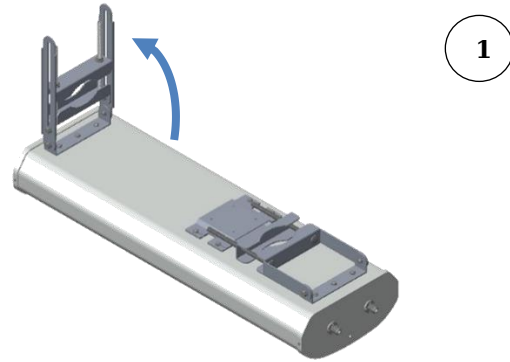

Figure 81 PMP 450i 900 MHz AP antenna inventory



- 2 (1) Unfold the upper bracket assembly of the antenna.



- (2) Unfold the lower bracket assembly.

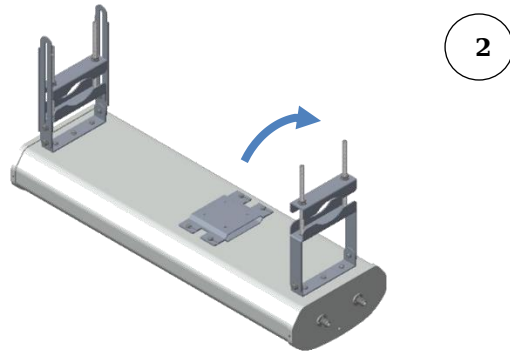

- (3) Loosen the radio assembly plate by untightening M8 four bolts.

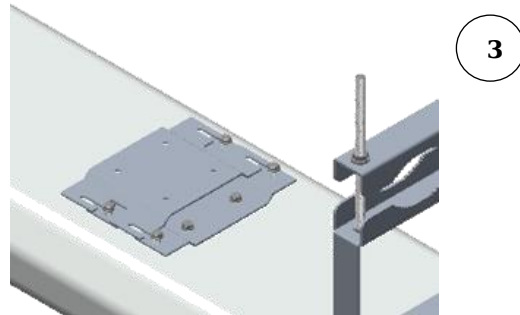

- (4) Remove the radio assembly top plate by sliding towards upper bracket assembly.

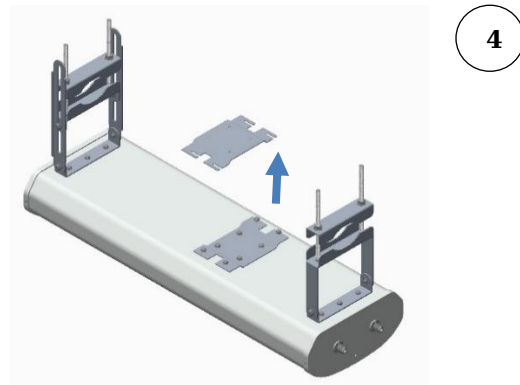

- 3** (1) Place the radio assembly plate on the radio and align holes with radio enclosure.

**Note**

Ensure that the radio plate notch opening and RF port of radio in same direction. It is also important to make sure you attach the radio assembly plate in the proper orientation as shown in figure.

- (2) Insert M8 bolts through plate into radio enclosure

- (3) Fix the plate by tightening four bolts with a torque setting on 2 ± 0.5 Nm

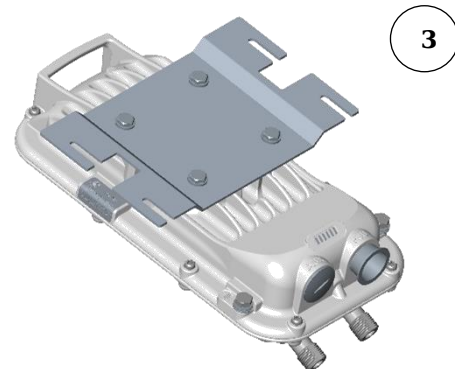
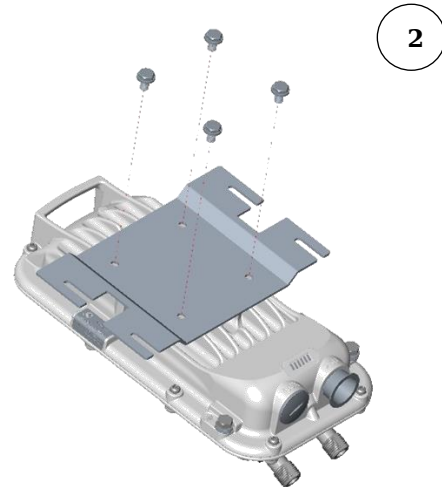
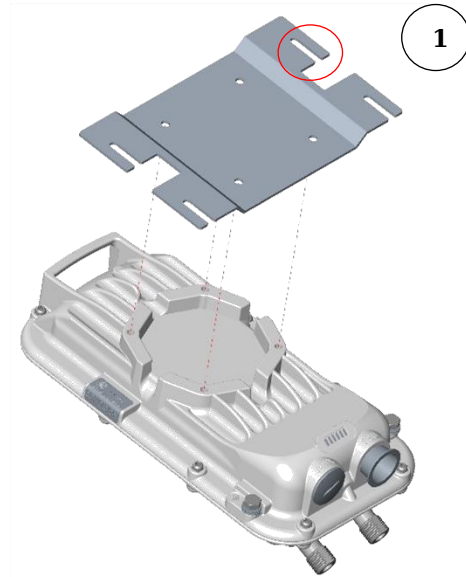

- 4** (1) Place the radio mounted plate on sector antenna as show figure. Ensure that the orientation of RF port of antenna and radio are in same direction

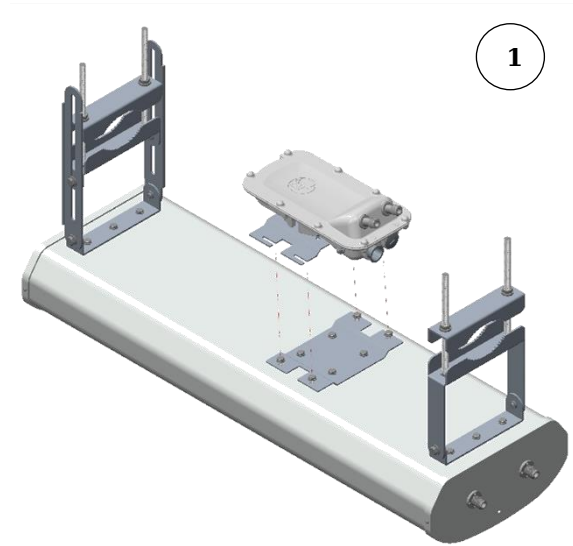

- (2) Line up the radio assembly to four bolts and slide towards lower bracket assembly to lock.

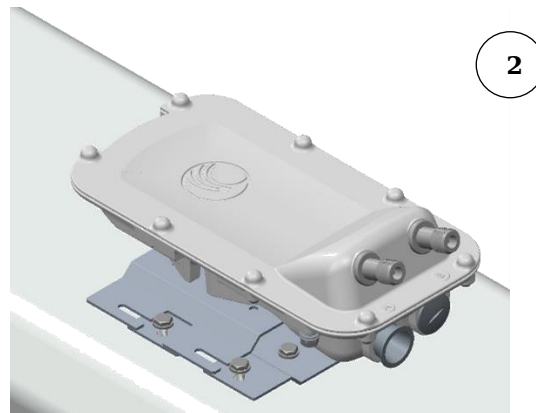

- (3) Tighten the radio assembly plate using four M8 bolts to a torque setting on 2 ± 0.5 Nm

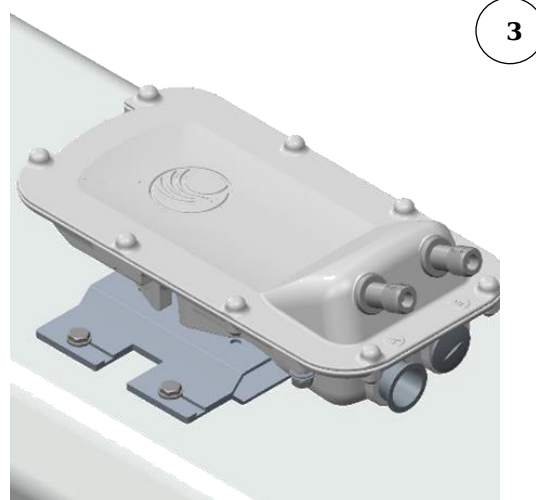

- 5** (1) Connect the port A of AP to vertical and port B of AP to horizontal polarization interfaces of the antenna with RF cable. Ensure that the RF cables are passthrough inside the lower bracket assembly

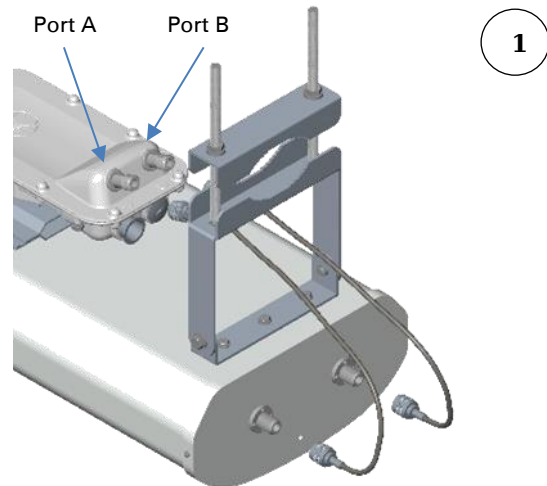

- (2) Hand tighten the N type connectors and the torque should not exceed more than 1 Nm

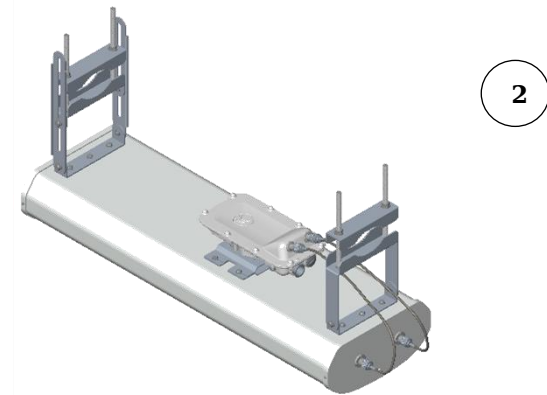

Mounting of PMP 450i 900 MHz AP antenna to the pole

The mounting procedure of PMP 450i 900 MHz AP and antenna to the pole is given below:

- 1** Remove the upper and lower rear bracket strap from the sector antenna.

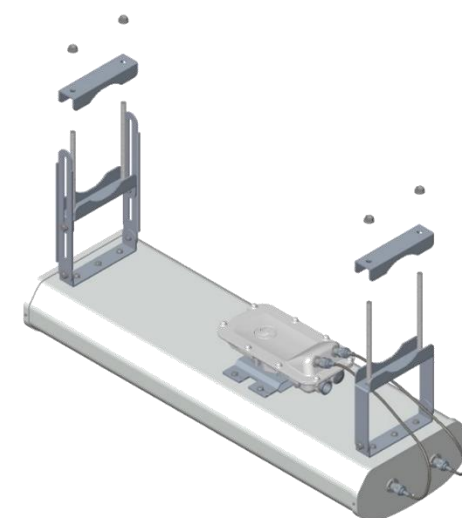

- 2 Attach the upper and lower bracket of the antenna to the mount point by closing the rear strap around the pole.

**Note**

Before mounting the radio on pole, secure upper and lower bracket assembly with a torque setting of 3 to 4 Nm as shown in Figure ①. Also, ensure that inner strap of upper bracket is set to zero degree marking.

Figure 82 Attaching radio mounting PMP 450i 900 MHz AP antenna to the pole

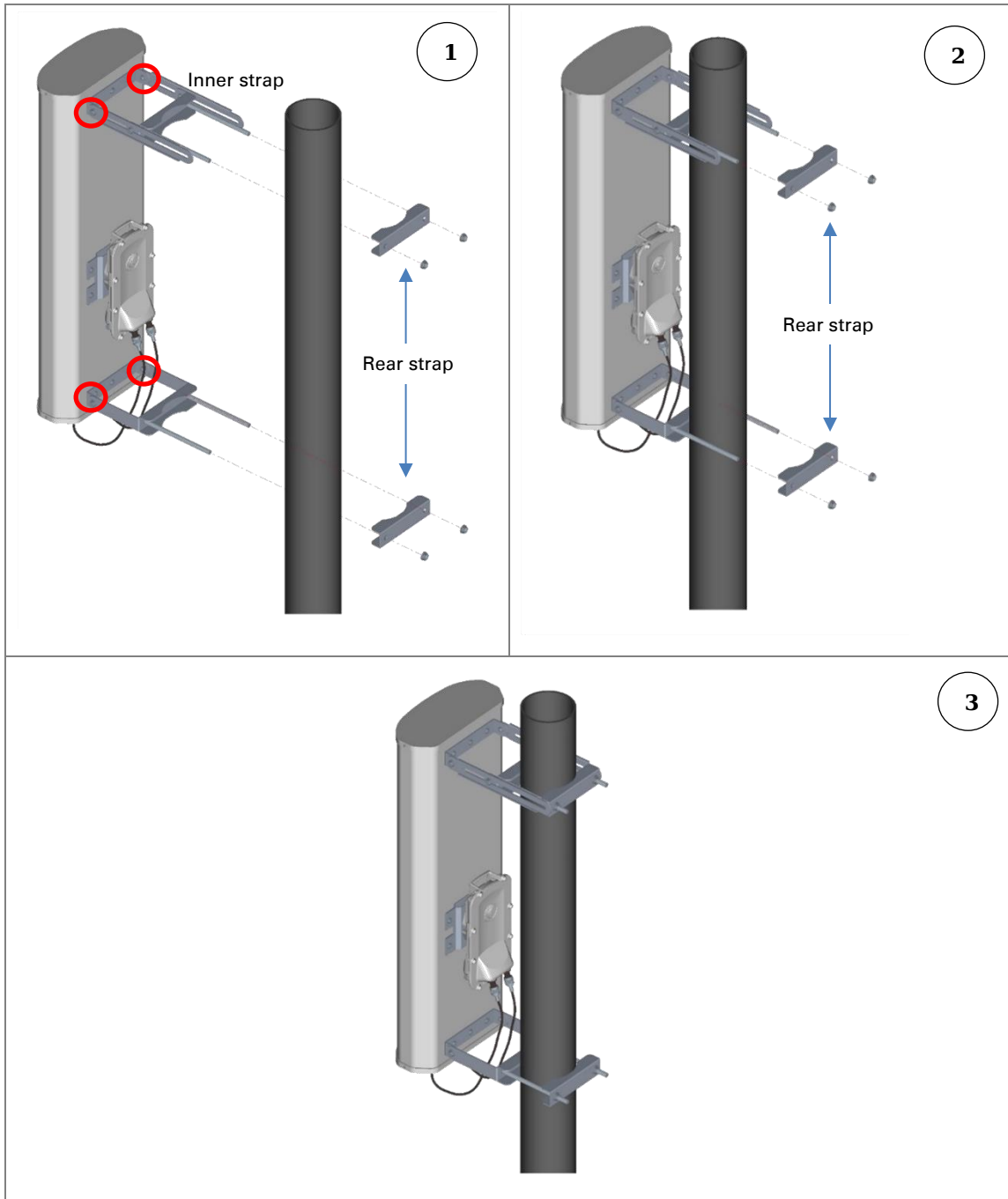

- 3 Tightening the four serrated flange M10 nuts on upper and lower rear strap using a 17 mm spanner wrench. These must be tightened evenly on the pole to avoid jumping/stripping threads

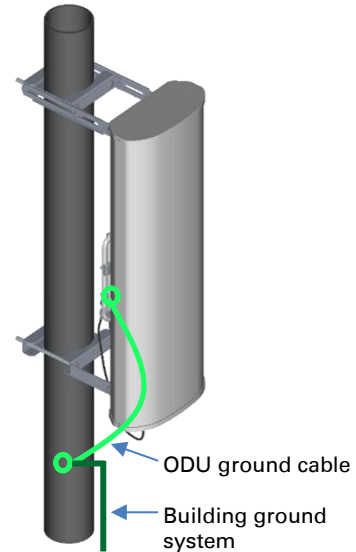

Sector antenna alignment

The 900 MHz sector antenna horizontal and vertical alignment procedure is shown in [Figure 83](#). The antenna can be aligned from +5 to -10 degree by adjusting inner strap of upper bracket assembly.

Figure 83 900 MHz sector antenna alignment

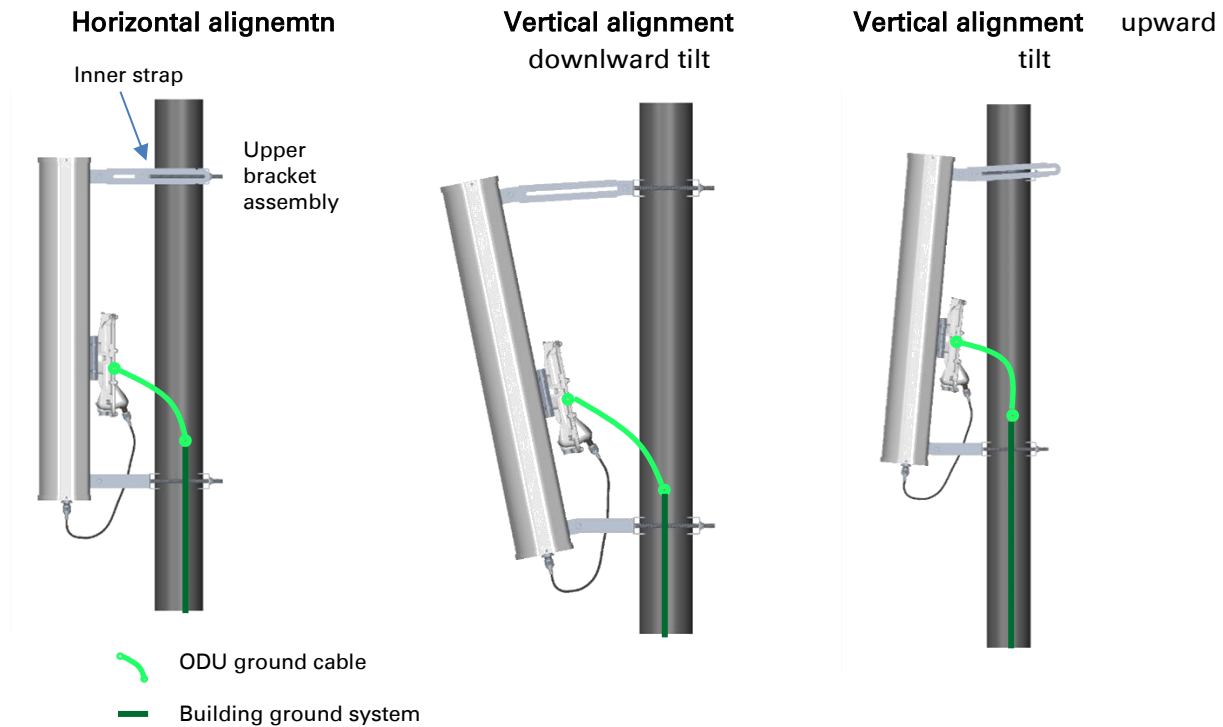

PMP 450 Series 900 MHz SM

Attaching the SM 900 MHz directional antenna to the pole

- 1 Unbox the directional yagi antenna.

Figure 84 PMP 450i 900 MHz SM external directional antenna

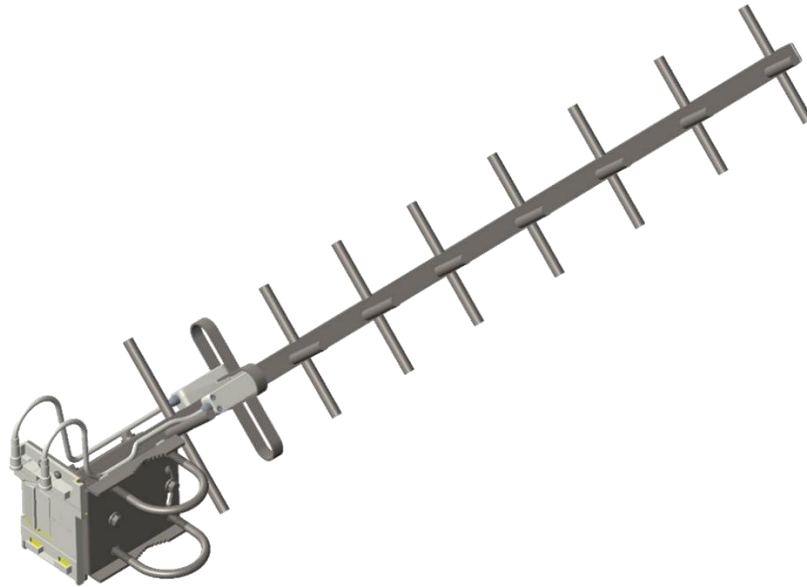

- 2 Attach the directional antenna to the pole and insert the two U clamps into the mounting bracket of the antenna

Figure 85 Attach the antenna to the pole

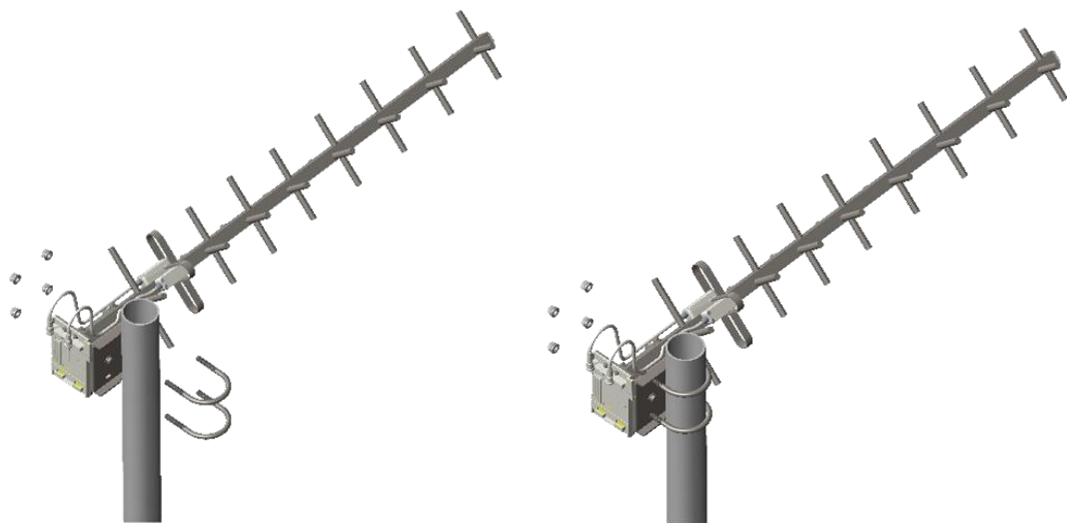

- 3 Tighten all nuts to approximately 6 to 7 Nm or less to avoid deforming the pole.

Figure 86 Fixing the nuts

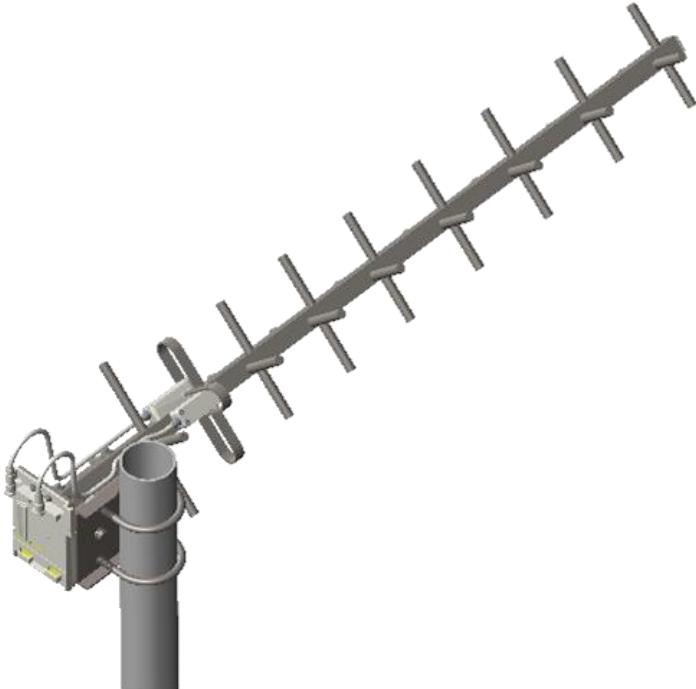

Radio mounting to the antenna

- 1 Align the radio to E bracket and slide towards right to lock on the antenna as shown in figure.

Figure 87 Fixing the radio to the antenna

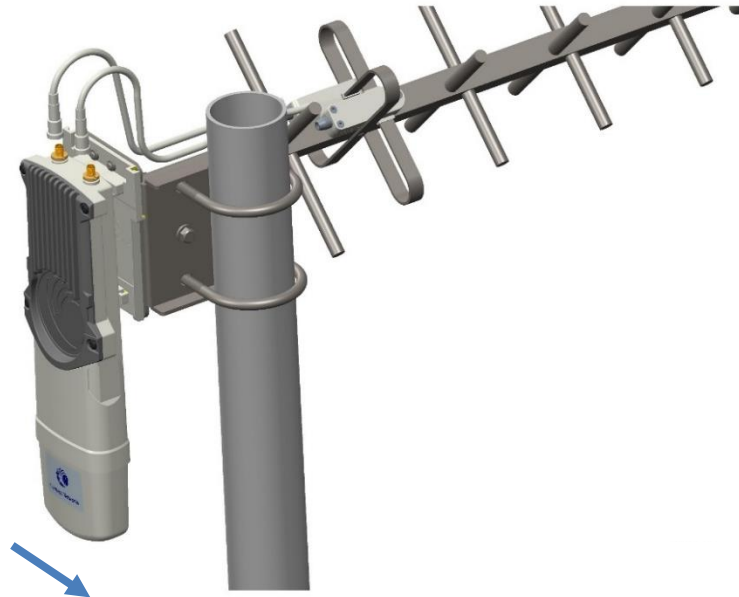

Slide towards right to lock

- 2 Connect the port A of SM to vertical and port B of SM to horizontal polarization interfaces of the antenna with RF cable.

Figure 88 Connecting RF cable to the radio

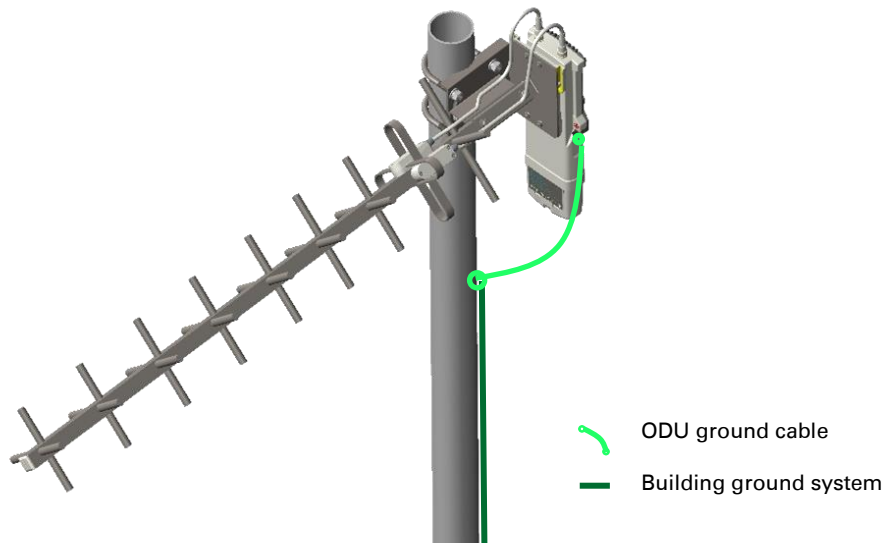

Directional Yagi antenna alignment

The directional Yagi antenna horizontal and vertical alignment procedure is shown below. The Yagi antenna can be aligned for +15 to -15 degree.

Figure 89 Yagi antenn alignment - horizontaly

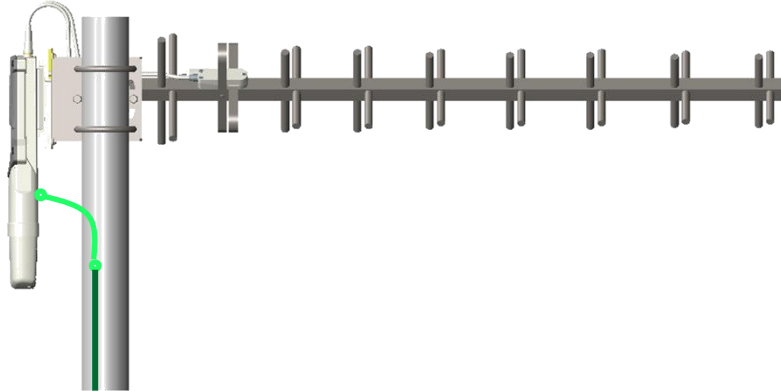

Figure 90 Yagi antenna alignment - upward tilt

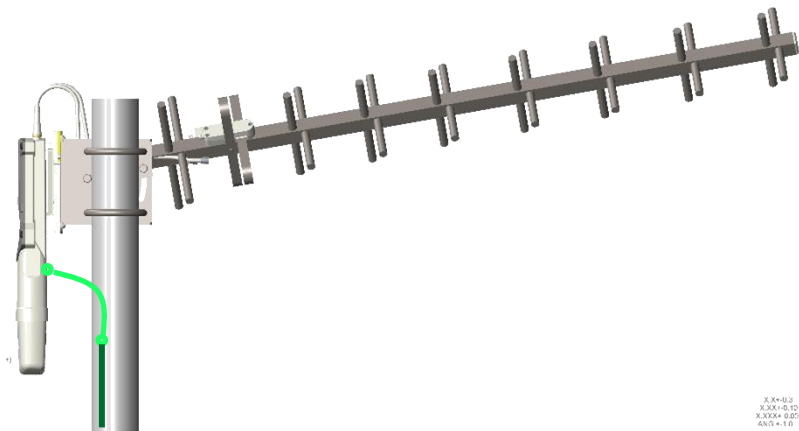
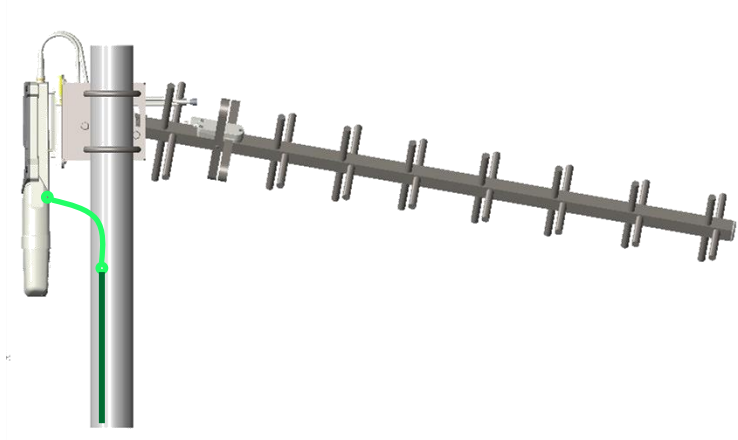

Figure 91 Yagi antenna alignment - downward tilt



Installing an integrated ODU



Caution

Do not reverse the bracket clamp, as this arrangement may lead to failure of the assembly. Do not over-tighten the bolts as this may lead to failure of the assembly.

PMP 450m Series – AP

To mount and connect an integrated ODU, proceed as follows:

- 1 Inventory the parts to ensure that you have them all before you begin. The full set of parts is shown in [Figure 92](#).

Figure 92 PMP 450m Series - AP unbox view

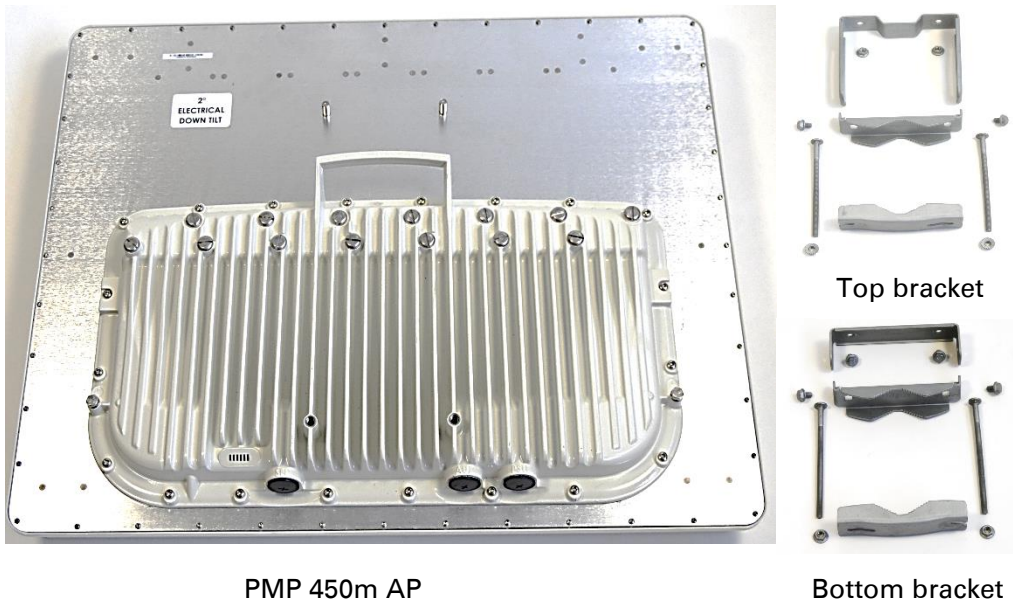

- 2 Attach the bottom bracket to ODU using (2) hex bolts and tighten the bolts.

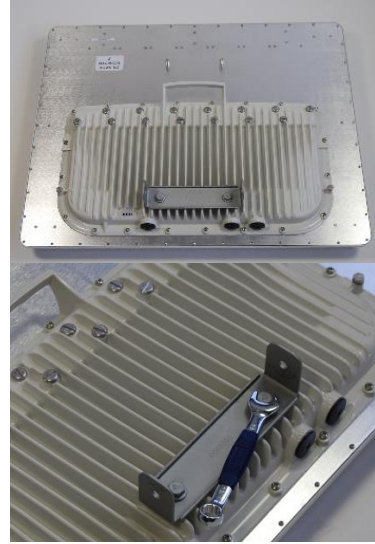

- 3 Insert the top bracket to projected two bolts of ODU and tighten the top bracket using two nuts.

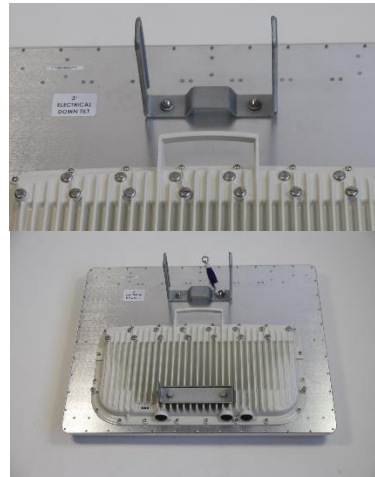

- 4 Fix the front and rear strap assembly to the upper bracket using two bolts. Do not tighten the nuts now.



- 5 Fix the front and rear strap assembly to the bottom bracket using two bolts. Do not tighten the nuts now.



- 6 See [PMP 450m Series – AP](#) on page [6-3](#) for grounding procedure

See [PMP 450m Series – AP](#) on page [6-6](#) for mounting procedure

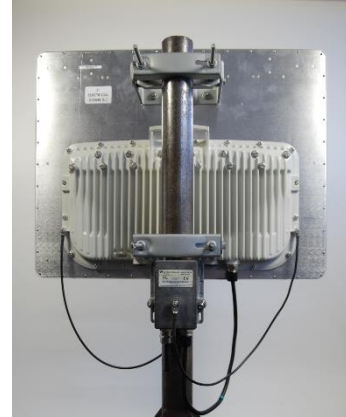

PMP/PTP 450i Series – AP/SM/BH

To mount and connect an integrated ODU, proceed as follows:

- 1 Fix the mounting plate to the back of the ODU using the four M6 bolts, and spring and plain washers provided. Tighten the bolts to a torque setting of 5.0 Nm (3.7 lb ft).

Figure 93 Fixing the mounting plate to the back of the ODU

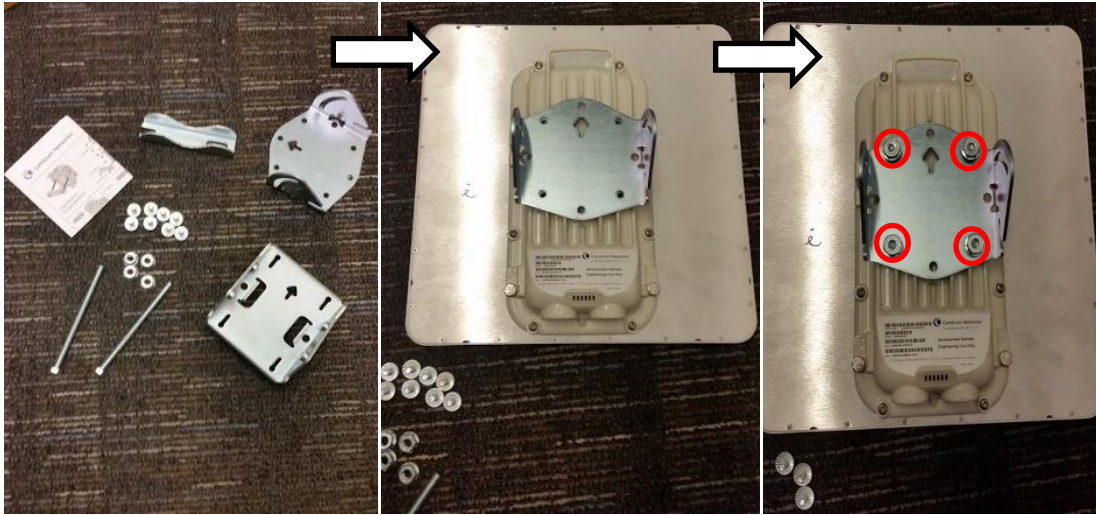

- 2 Attach the bracket body to the mounting plate using the M8 bolt, spring and plain washers.
- 3 Hoist the ODU to the mounting position.
- 4 Attach the bracket body to the pole using the bracket clamp, M8 bolts, and spring and plain washers.
- 5 If the ODU is mounted outdoors, weatherproof the N type connectors (when antenna alignment is complete) using PVC tape and self-amalgamating rubber tape.

Figure 94 Attaching the bracket body

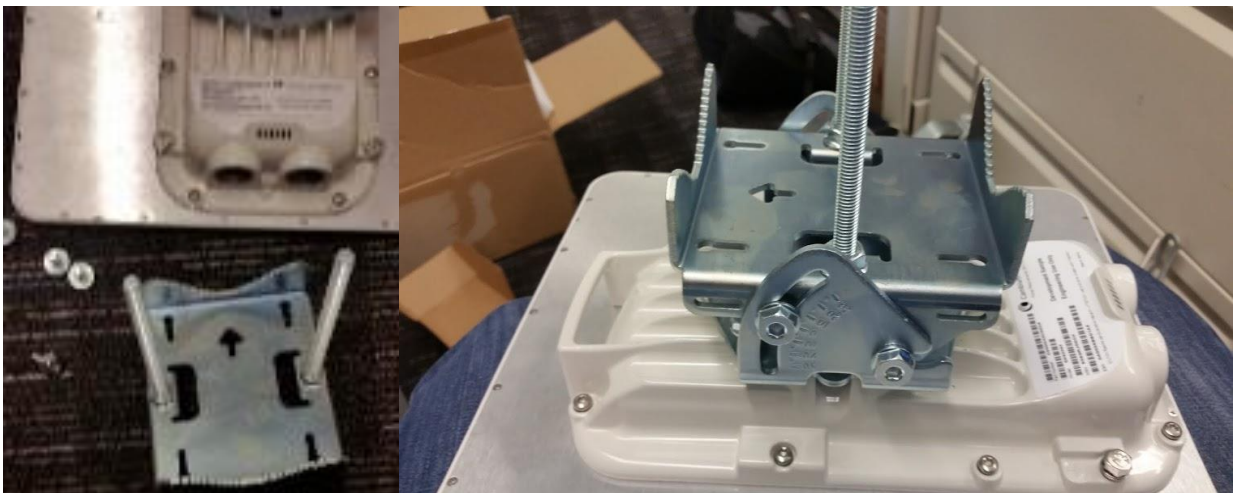

Connecting Cat5e Ethernet cable

Connecting an RJ45 and gland to a unit

Perform this task to connect the Ethernet cable to an AP.

To connect the Ethernet cable with a gland to an AP unit, proceed as follows:

- 1 Insert the RJ45 cable through the gland components
- 2 Insert the RJ45 plug into the socket in the unit, making sure that the locking tab snaps home.
- 3 Support the drop cable and gently hand screw the gland body into the unit until the bushing seal is flush to the unit body.

**Note**

Do not fit the back shell prior to securing the gland body.

- 4 Once the gland is fully hand screwed into the unit, tighten it one full rotation only with a 1/8 inch spanner wrench.
- 5 When the gland body has been fitted, tighten the gland back shell.

**Caution**

Do not over-tighten the gland back shell, as the internal seal and structure or RJ45 port may be damaged.

Figure 95 Ethernet cable gland for PMP/PTP 450 Series



Figure 96 Ethernet cable gland for PMP/PTP 450i Series



Figure 97 Ethernet cable gland for PMP 450m Series

Disconnecting an RJ45 and gland from a unit

Perform this task to disconnect the Ethernet cable and watertight gland from ODU.

To disconnect the Ethernet cable and gland from a unit, proceed as follows:

- 1 Hold Ethernet cable and remove the gland back shell
- 2 Use a small flathead screwdriver (0.2"/5mm wide or greater) to gently release the black plastic watertight bushing from the compression fins, being careful not to damage the bushing.
- 3 Unscrew the gland body from the AP, making sure that the Ethernet cable is not rotating while disengaging the gland body from the AP housing
- 4 Use a small screwdriver to depress the RJ45 locking clip
- 5 Unplug the RJ45 cable
- 6 Remove the gland from the cable, if necessary

Installing ODU

Installing an PMP 450 platform AP

To install a PMP 450 platform Series AP, perform the following steps.

Procedure 5 Installing an AP

- 1 Begin with the AP in the powered-down state.
- 2 Choose the best mounting location for your particular application. Modules need not be mounted next to each other. They can be distributed throughout a given site. However, the 60° offset must be maintained. Mounting can be done with supplied clamps.
See [Installing external antennas to a connectorized ODU](#) on page 6-21 for connecting external antenna to [PMP 450i Series](#), [PMP 450 Series](#), [PMP 450i Series 900 MHz AP](#) and [PMP 450 Series 900 MHz SM](#)
See [Installing an integrated ODU](#) on page 6-49
- 3 Align the AP as follows:
 - a. Move the module to where the link will be unobstructed by the radio horizon and no objects penetrate the Fresnel zone.
 - b. Use a local map, compass, and/or GPS device as needed to determine the direction that one or more APs require to each cover the intended 60° sector.
 - c. Apply the appropriate degree of downward tilt.
 - d. Ensure that the nearest and furthest SMs that must register to this AP are within the beam coverage area.
- 4 Adjust the azimuth to achieve visual alignment, lock the AP in the proper direction and downward tilt.
- 5 Attach the cables to the AP (See [Powering the AP/SM/BH for test configuration](#) on Page 5-15)
- 6 Weatherproof the cables (See section [Attaching and weatherproofing an N type connector](#) on page 6-68).

Installing a PMP 450 platform SM

Installing a PMP 450 platform Series SM consists of two procedures:

- Physically installing the SM on a residence or other location and performing a coarse alignment using the alignment tool or alignment tone.
- Verifying the AP to SM link and finalizing alignment using review of power level, link tests, and review of registration and session counts.

Procedure 6 Installing an SM

- 1 Choose the best mounting location for the SM based on section [ODU and external antenna location](#) on page 3-10.
- 2 Use stainless steel hose clamps or equivalent fasteners to lock the SM into position. See [Installing external antennas to a connectorized ODU](#) on page 6-21 for connecting external antenna
See [Installing an integrated ODU](#) on page 6-49
- 3 Remove the base cover of the SM.
- 4 Terminate the UV outside grade Category 5 Ethernet cable with an RJ-45 connector, and connect the cable to the SM.
- 5 Wrap a drip loop in the cable.
- 6 For Connectorized Models, Install the external antenna according to the manufacturer's instructions.
- 7 For Connectorized Models, connect the SM's N-type antenna connectors to the external antenna, ensuring that the polarity matches between the SM cable labeling and the antenna port labels.

Connectorized SM Antenna Cable Label	Antenna Connection
A	Vertical
B	Horizontal

- 8 For Connectorized Models, weatherproof the N-type antenna connectors following section [Attaching and weatherproofing an N type connector](#) on page 6-68.
- 9 Wrap an AWG 10 (or 6mm²) copper wire around the Ground post of the SM
- 10 Securely connect the copper wire to the grounding system (Protective Earth) according to applicable regulations.
- 11 Install a surge suppressor as describe in section [Mount the Surge Suppressor](#) on page 6-9
- 12 Connect the power supply to a power source.
- 13 Connect the Ethernet output from the power supply to the Ethernet port of your laptop.

- 14 Launch your web browser. In the URL address bar, enter **169.254.1.1**. then press Enter.
- 15 If the browser in laptop fails to access the interface of the SM, follow the procedure [Radio recovery mode](#) on page 1-22
- 16 Log in as admin on the ODU. Configure a password for the admin account and log off.
- 17 Log back into the SM as admin or root, using the password that you configured.
- 18 For coarse alignment of the SM, use the Alignment Tool located at **Tools, Alignment Tool**.
Optionally, connect a headset to the AUX/SYNC port the SM and listen to the alignment tone, which indicates greater SM receive signal power by pitch. By adjusting the SM's position until the highest frequency pitch is obtained operators and installers can be confident that the SM is properly positioned. For information on device GUI tools available for alignment, see sections [Using the Alignment Tool](#), [Using the Link Capacity Test tool](#), and [Using AP Evaluation tool](#) below.
- 19 When the highest power achieved, lock the SM mounting bracket in place.
- 20 Log off of the SM web interface.
- 21 Disconnect the Ethernet cable from your laptop.
- 22 Replace the base cover of the SM.
- 23 Connect the Ethernet cable to the computer that the subscriber will be using.

Installing a PTP 450 platform BHM

To install a PTP 450 platform Series BHM, perform the following steps.

Procedure 7 Installing a BHM

- 1 Access the General tab of the Configuration page in the BHM
- 2 Choose the best mounting location for your particular application.
- 3 Align the BHM as follows:
 - a. Move the module to where the link will be unobstructed by the radio horizon and no objects penetrate the Fresnel zone.
 - b. Use a local map, compass, and/or GPS device as needed to determine the direction to the BHS.
 - c. Apply the appropriate degree of downward or upward tilt.
 - d. Ensure that the BHS is within the beam coverage area.

- 4 Using stainless steel hose clamps or equivalent fasteners, lock the BHM into position.
See [Installing external antennas to a connectorized ODU](#) on page 6-21 for connecting external antenna
- 5 If this BHM will not be connected to a CMM, optionally connect a utility cable to a GPS timing source and then to the SYNC port of the BHM.
- 6 Either connect the BHM's Aux to the CMM or connect the DC power converter to the BHM and then to an AC power source.
RESULT: When power is applied to a module or the unit is reset on the web-based interface, the module requires approximately 25 seconds to boot. During this interval, self-tests and other diagnostics are being performed.
- 7 Access **Configuration > General** page of the BHM for Synchronization configuration.
- 8 If a CMM4 is connected, set the **Sync Input** parameter to the AutoSync or Autosync + Free Run selection.

Installing a PTP 450 platform BHS

To install a PTP 450 platform Series BHS, perform the following steps.

Procedure 8 Installing a BHS

- 1 Choose the best mounting location for the BHS.
- 2 Terminate the UV outside grade Category 5 Ethernet cable with an RJ-45 connector, and connect the cable to the BHS. (See [Powering the AP/SM/BH for test configuration](#) on Page 5-15)
- 3 Use stainless steel hose clamps or equivalent fasteners to lock the BHS into position.
- 4 Install an surge suppressor as describe in section [Mount the Surge Suppressor](#) on page 6-9
- 5 For coarse alignment of the BHS, use the Audible Alignment Tone feature as follows:
 - a. At the BHS, connect the RJ-45 connector of the Alignment Tool Headset to the Aux port via alignment tone adapter as shown in [Figure 158](#) on page 8-20.
 - b. Listen to the alignment tone for pitch, which indicates greater signal power (RSSI/dBm) by higher pitch.
Adjust the module slightly until you hear the highest pitch and highest volume
- 6 When you have achieved the best signal (highest pitch, loudest volume), lock the BHS in place with the mounting hardware

Configuring the Link

See [Configuring remote access](#) on page 7-255.

Monitoring the Link

See [Monitoring the Link](#) on page 7-256.

Installing the AC Power Injector



Caution

As the PSU is not waterproof, locate it away from sources of moisture, either in the equipment building or in a ventilated moisture-proof enclosure. Do not locate the PSU in a position where it may exceed its temperature rating.



Caution

Do not plug any device other than a PMP/PTP 450i ODU into the ODU port of the PSU. Other devices may be damaged due to the non-standard techniques employed to inject DC power into the Ethernet connection between the PSU and the ODU.

Do not plug any device other than a Cambium PMP/PTP 450 platform PSU into the PSU port of the ODU. Plugging any other device into the PSU port of the ODU may damage the ODU and device.

Installing the AC Power Injector

Follow this procedure to install the AC Power Injector:

- 1 Form a drip loop on the PSU end of the LPU to PSU drop cable. The drip loop ensures that any moisture that runs down the cable cannot enter the PSU.
- 2 (a) Place the AC Power Injector on a horizontal surface. Plug the LPU to PSU drop cable into the PSU port labeled ODU. (b) When the system is ready for network connection, connect the network Cat5e cable to the LAN port of the PSU:

(a)



(b)



Installing CMM4



Note

For instructions on CMM3 (CMMmicro) or CMM4 installation, including the outdoor temperature range in which it is acceptable to install the unit, tools required, mounting and cabling instructions, and connectivity verification, please see the *PMP Synchronization Solutions User Guide* located on the Cambium website.

The Cluster Management Module 4 (CMM4) provides power, sync, and network connectivity for up to eight APs, backhauls, and Ethernet terrestrial feeds in a variety of configurations. The CMM4 provides

- Sync over Power over Ethernet and integrated surge suppression on the controller board for up to 8 APs or BHs. Both a custom 30 VDC power scheme and a custom 56 VDC power scheme are available. Neither is the same as the later IEEE Standard 802.3af, and neither is compatible with it.
- Managed switching using a hardened EtherWAN switch (1090CKHH models). The CMM4 ships with a 14-port EtherWAN switch and is also available without a switch. The CMM4 originally shipped with a 9-port EtherWAN switch.
- Surge suppression on the controller board for the incoming 30V DC and 56V DC power lines and GPS coax cable.
- Auto-negotiation on the Ethernet ports. Ports will auto-negotiate to match inputs that are either 100Base-T or 10Base-T, and either full duplex or half duplex, when the connected device is set to auto-negotiate. Alternatively, these parameters are settable.
- An always-on NTP (Network Time Protocol) server that can provide date and time to any radio that can reach the CMM's management IP address.
- CNUT can be used to upgrade the CMM-4 software.

PMP/PTP 450 platform can use the CMM4's EtherWan switch for their network connectivity.



Note

The 56V of a CMM4 needs to go through the adapter cable (part number N000045L001A) as shown in [Figure 24](#) on page [2-36](#).

The CMM4 56V power adapter cable can be prepared by swapping pins 5 and 7. See [CMM4 56V power adapter cable pinout](#) on page [2-36](#) for power adapter cable pinout.

Figure 98 CMM4 cabled to support PMP/PTP 450 platform

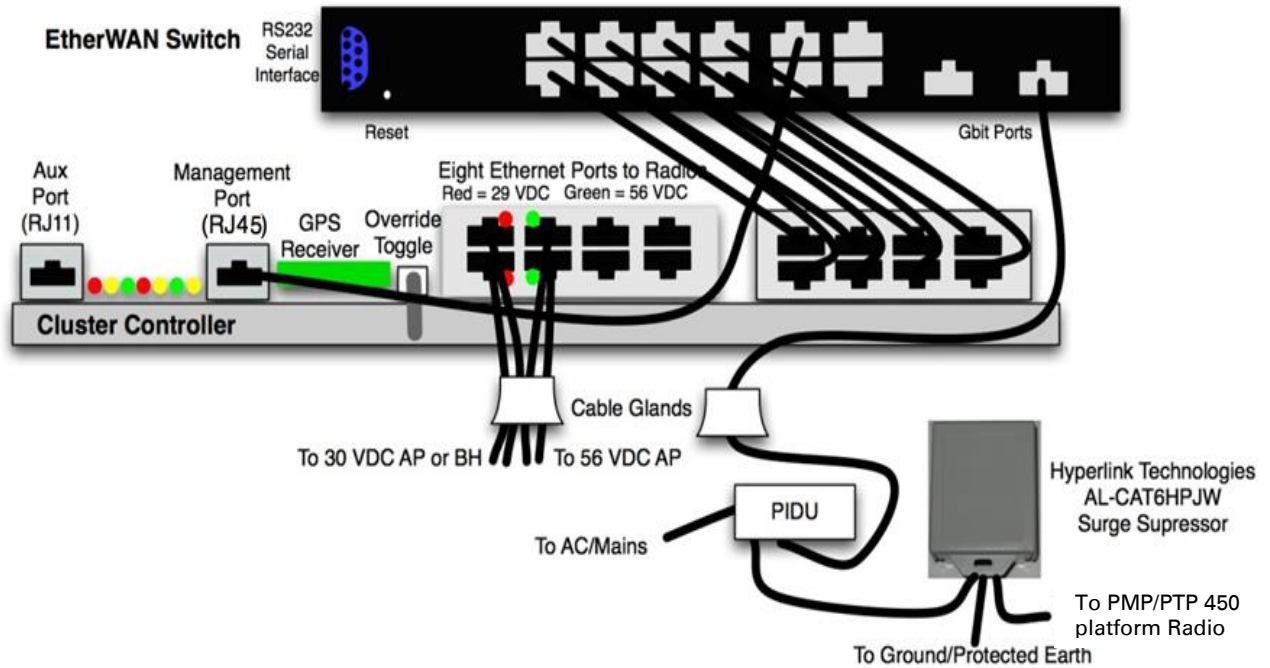

Supplemental installation information

This section contains detailed installation procedures that are not included in the above topics, such as how to strip cables, create grounding points and weatherproof connectors.

Stripping drop cable

When preparing drop cable for connection to the PMP/PTP 450 platform ODU or LPU, use the following measurements:

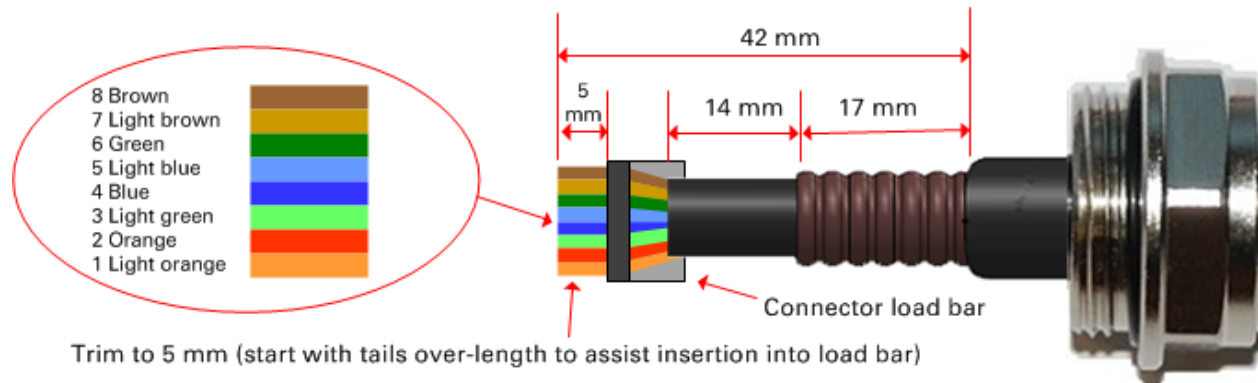

When preparing drop cable for connection to the PMP/PTP 450 platform PSU (without a cable gland), use the following measurements:

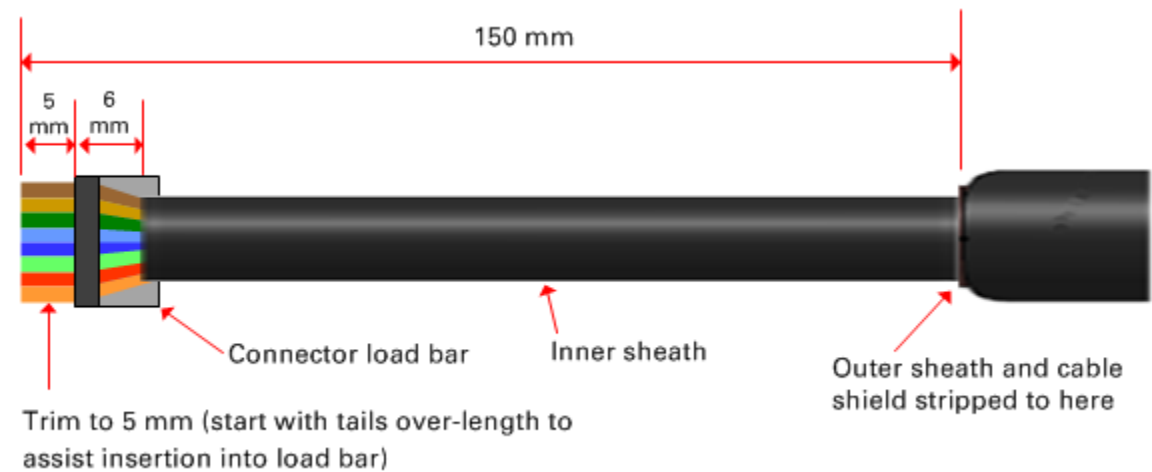

Creating a drop cable grounding point

Use this procedure to connect the screen of the main drop cable to the metal of the supporting structure using the cable grounding kit (Cambium part number 01010419001).

To identify suitable grounding points, refer to [Drop cable grounding points](#) on page 3-14.

- 1 Remove 60 mm (2.5 inches) of the drop cable outer sheath.

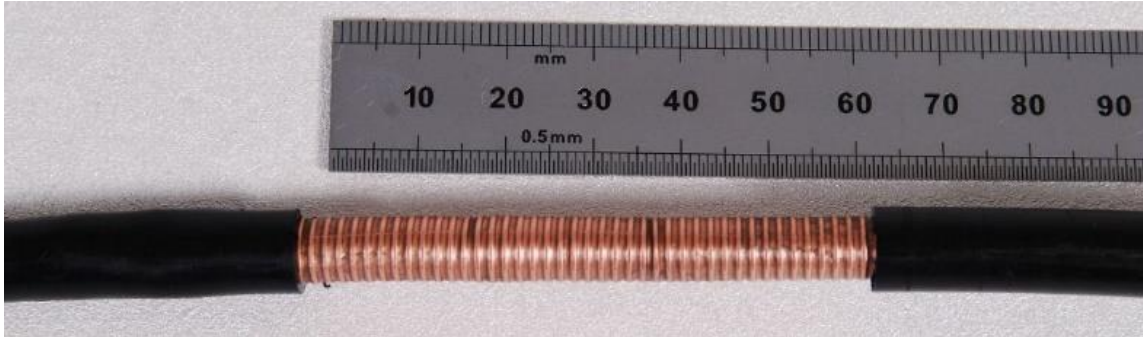

- 2 Cut 38mm (1.5 inches) of rubber tape (self-amalgamating) and fit to the ground cable lug. Wrap the tape completely around the lug and cable.



- 3 Fold the ground wire strap around the drop cable screen and fit cable ties.



- 4 Tighten the cable ties with pliers. Cut the surplus from the cable ties.



- 5 Cut a 38mm (1.5 inches) section of self-amalgamating tape and wrap it completely around the joint between the drop and ground cables.



- 6 Use the remainder of the self-amalgamating tape to wrap the complete assembly. Press the tape edges together so that there are no gaps.



- 7 Wrap a layer of PVC tape from bottom to top, starting from 25 mm (1 inch) below and finishing 25 mm (1 inch) above the edge of the self-amalgamating tape, overlapping at half width.



- 8 Repeat with a further four layers of PVC tape, always overlapping at half width. Wrap the layers in alternate directions (top to bottom, then bottom to top). The edges of each layer should be 25mm (1 inch) above (A) and 25 mm (1 inch) below (B) the previous layer.



- 9 Prepare the metal grounding point of the supporting structure to provide a good electrical contact with the grounding cable clamp. Remove paint, grease or dirt, if present. Apply anti-oxidant compound liberally between the two metals.
- 10 Clamp the bottom lug of the grounding cable to the supporting structure using site approved methods. Use a two-hole lug secured with fasteners in both holes. This provides better protection than a single-hole lug.

Attaching and weatherproofing an N type connector

The following procedure should be used to weatherproof the N type connectors fitted to the connectorized ODU (AP/SM/BH) and antenna. This procedure must be followed to ensure that there is no moisture ingress at the radio ports. Failure to properly seal N-type antenna connectors can result in poor link performance or complete loss of radio communication.

**Note**

Cambium recommends to assemble the antenna, attach the ODU and cabling, and to seal the RF connections before installing the unit at the deployment site.

**Note**

N type connectors should be tightened using a torque wrench, set to 15 lb in or 1.7 Nm. If a torque wrench is not available, N type connectors may be finger tightened.

Use this procedure to weatherproof the N type connectors fitted to the connectorized ODU and external antenna (if recommended by the antenna manufacturer).

- 1 Ensure the connection is tight. A torque wrench should be used if available:



- 2 Wrap the connection with a layer of 19 mm (0.75 inch) PVC tape, starting 25 mm (1 inch) below the connector body. Overlap the tape to half-width and extend the wrapping to the body of the LPU. Avoid making creases or wrinkles:



- 3** Smooth the tape edges:



- 4** Cut a 125mm (5 inches) length of rubber tape (self-amalgamating):

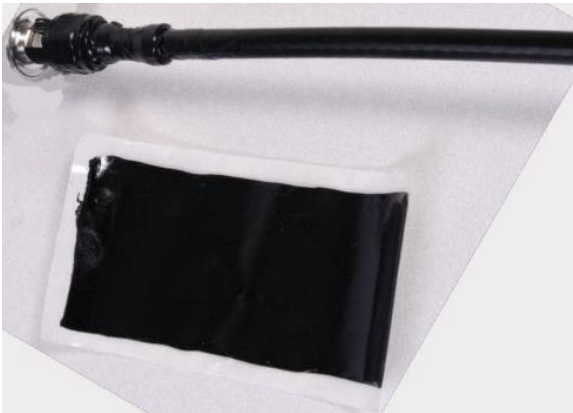

- 5** Expand the width of the tape by stretching it so that it will wrap completely around the connector and cable:



- 6** Press the tape edges together so that there are no gaps. The tape should extend 25 mm (1 inch) beyond the PVC tape:



- 7 Wrap a layer of 50 mm (2 inch) PVC tape from bottom to top, starting from 25 mm (1 inch) below the edge of the self-amalgamating tape, overlapping at half width.



- 8 Repeat with a further four layers of 19 mm (0.75 inch) PVC tape, always overlapping at half width. Wrap the layers in alternate directions:
- Second layer: top to bottom.
 - Third layer: bottom to top.
 - Fourth layer: top to bottom.
 - Fifth layer: bottom to top.

The bottom edge of each layer should be 25 mm (1 inch) below the previous layer.



- 9 Check the completed weatherproof connection:



Note

A video of this procedure can be found at:

<https://www.youtube.com/watch?v=a-twPfCVq4A>
