

PMP/PTP 450i Series – AP/SM/BH

To mount and connect an integrated ODU, proceed as follows:

- 1 Fix the mounting plate to the back of the ODU using the four M6 bolts, and spring and plain washers provided. Tighten the bolts to a torque setting of 5.0 Nm (3.7 lb ft).

Figure 115 Fixing the mounting plate to the back of the ODU

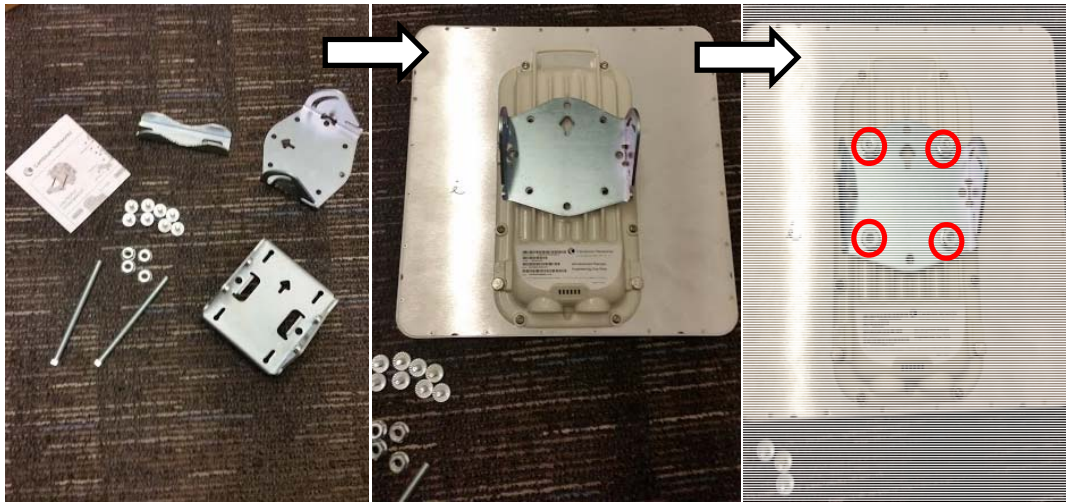

- 2 Attach the bracket body to the mounting plate using the M8 bolt, spring and plain washers.
- 3 Hoist the ODU to the mounting position.
- 4 Attach the bracket body to the pole using the bracket clamp, M8 bolts, and spring and plain washers.
- 5 If the ODU is mounted outdoors, weatherproof the N type connectors (when antenna alignment is complete) using PVC tape and self-amalgamating rubber tape.

Figure 116 Attaching the bracket body



Connecting Cat5e Ethernet cable

Connecting an RJ45 and gland to a unit

Perform this task to connect the Ethernet cable to an AP.

To connect the Ethernet cable with a gland to an AP unit, proceed as follows:

- 1 Insert the RJ45 cable through the gland components
- 2 Insert the RJ45 plug into the socket in the unit, making sure that the locking tab snaps home.
- 3 Support the drop cable and gently hand screw the gland body into the unit until the bushing seal is flush to the unit body.

**Note**

Do not fit the back shell prior to securing the gland body.

- 4 Once the gland is fully hand screwed into the unit, tighten it one full rotation only with a 1 1/8 inch spanner wrench.
- 5 When the gland body has been fitted, tighten the gland back shell.

**Caution**

Do not over-tighten the gland back shell, as the internal seal and structure or RJ45 port may be damaged.

Figure 117 Ethernet cable gland for PMP/PTP 450 Series



Figure 118 Ethernet cable gland for PMP/PTP 450i Series



Disconnecting an RJ45 and gland from a unit

To disconnect the Ethernet cable and gland from a unit, proceed as follows:

- 1 Hold the Ethernet cable and remove the gland back shell.
- 2 Use a small flathead screwdriver (0.2"/5mm wide or greater) to gently release the black plastic watertight bushing from the compression fins, being careful not to damage the bushing.
- 3 Unscrew the gland body from the AP, making sure that the Ethernet cable is not rotating while disengaging the gland body from the AP housing.
- 4 Use a small screwdriver to depress the RJ45 locking clip.
- 5 Unplug the RJ45 cable.
- 6 Remove the gland from the cable, if necessary.

Installing ODU

Installing a 450 Platform Family AP

To install a 450 Platform Family AP, perform the following steps.

Procedure 5 Installing an AP

- 1 Begin with the AP in the powered-down state.
- 2 Choose the best mounting location for your particular application. Modules need not be mounted next to each other. They can be distributed throughout a given site. However, the 60° offset must be maintained. Mounting can be done with supplied clamps.
See [Installing external antennas to a connectorized ODU](#) on page 6-23 for connecting an external antenna to [PMP 450i Series](#), [PMP 450 Series](#), [PMP 450i Series AP 900 MHz](#) and [PMP 450 Series SM](#)
See [Installing an integrated ODU](#) on page 6-52
- 3 Align the AP as follows:
 - a. Move the module to where the link will be unobstructed by the radio horizon and no objects penetrate the Fresnel zone.
 - b. Use a local map, compass, and/or GPS device as needed to determine the direction that one or more APs require to each cover the intended 60° sector.
 - c. Apply the appropriate degree of downward tilt.
 - d. Ensure that the nearest and furthest SMs that must register to this AP are within the beam coverage area.
- 4 Adjust the azimuth to achieve visual alignment, lock the AP in the proper direction and downward tilt.
- 5 Attach the cables to the AP (See [Powering the AP/SM/BH for test configuration](#) on Page 5-16)
- 6 Waterproof the cables (See section [Attaching and weatherproofing an N type connector](#) on page 6-69).

Installing a 450 Platform Family SM

Installing a 450 Platform Family SM consists of two procedures:

- Physically installing the SM on a residence or other location and performing a coarse alignment using the alignment tool or alignment tone.
- Verifying the AP to SM link and finalizing alignment using review of power level, link tests, and review of registration and session counts.

Procedure 6 Installing an SM

- 1 Choose the best mounting location for the SM based on section [ODU and external antenna location](#) on page 3-10.
- 2 Use stainless steel hose clamps or equivalent fasteners to lock the SM into position.
See [Installing external antennas to a connectorized ODU](#) on page 6-23 for connecting external antenna
See [Installing an integrated ODU](#) on page 6-52
- 3 Remove the base cover of the SM.
- 4 Terminate the UV outside grade Category 5 Ethernet cable with an RJ-45 connector, and connect the cable to the SM.
- 5 Wrap a drip loop in the cable.
- 6 For Connectorized Models, Install the external antenna according to the manufacturer's instructions.
- 7 For Connectorized Models, connect the SM's N-type antenna connectors to the external antenna, ensuring that the polarity matches between the SM cable labeling and the antenna port labels.

Connectorized SM Antenna Cable Label	Antenna Connection
A	Vertical
B	Horizontal

- 8 For Connectorized Models, weatherproof the N-type antenna connectors following section [Attaching and weatherproofing an N type connector](#) on page 6-69.
- 9 Wrap an AWG 10 (or 6mm²) copper wire around the Ground post of the SM
- 10 Securely connect the copper wire to the grounding system (Protective Earth) according to applicable regulations.
- 11 Install a surge suppressor as described in the section [Mount the Surge Suppressor](#) on page 6-10.
- 12 Connect the power supply to a power source.
- 13 Connect the Ethernet output from the Data port of the power supply to the Ethernet port of your laptop.

- 14 Connect the drop cable from ODU to the Data+power port of the power supply.
- 15 Launch your web browser. In the URL address bar, enter **169.254.1.1**. then press Enter.
- 16 If the browser in laptop fails to access the interface of the SM, follow the procedure [Radio recovery mode](#) on page 1-26
- 17 Log in as admin on the ODU. Configure a password for the admin account and log off.
- 18 Log back into the SM as admin or root, using the password that you configured.
- 19 For coarse alignment of the SM, use the Alignment Tool located at **Tools, Alignment Tool**.
Optionally, connect a headset to the AUX/SYNC port on the SM and listen to the alignment tone, which indicates greater SM receive signal power by pitch. By adjusting the SM's position until the highest frequency pitch is obtained operators and installers can be confident that the SM is properly positioned. For information on device GUI tools available for alignment, see sections [Using the Alignment Tool](#), [Using the Link Capacity Test tool](#), and [Using AP Evaluation tool](#) below.
- 20 When the highest power is achieved, lock the SM mounting bracket in place.
- 21 Log off of the SM web interface.
- 22 Disconnect the Ethernet cable from your laptop.
- 23 Replace the base cover of the SM.
- 24 Connect the Ethernet cable to the computer that the subscriber will be using.

Installing a 450 Platform Family BHM

To install a 450 Platform Family BHM, perform the following steps.

Procedure 7 Installing a BHM

- 1 Choose the best mounting location for your particular application.
- 2 Align the BHM as follows:
 - a. Move the module to where the link will be unobstructed by the radio horizon and no objects penetrate the Fresnel zone.
 - b. Use a local map, compass, and/or GPS device as needed to determine the direction to the BHS.
 - c. Apply the appropriate degree of downward or upward tilt.
 - d. Ensure that the BHS is within the beam coverage area.
- 3 Using stainless steel hose clamps or equivalent fasteners, lock the BHM into position.
See [Installing external antennas to a connectorized ODU](#) on page 6-23 for connecting external antenna
- 4 If this BHM will not be connected to a CMM, optionally connect a cable to a GPS timing source and then to the SYNC port of the BHM.

- 5 Either connect the BHM's Aux to the CMM or connect the DC power converter to the BHM and then to an AC power source.
RESULT: When power is applied to a module or the unit is reset on the web-based interface, the module requires approximately 25 seconds to boot. During this interval, self-tests and other diagnostics are being performed.
- 6 Access **Configuration > General** page of the BHM for Synchronization configuration.
- 7 If a CMM4 is connected, set the **Sync Input** parameter to the AutoSync or Autosync + Free Run selection.

Installing a 450 platform BHS

To install a PTP 450 platform Series BHS, perform the following steps.

Procedure 8 Installing a BHS

- 1 Choose the best mounting location for the BHS.
- 2 Terminate the UV outside grade Category 5 Ethernet cable with an RJ-45 connector, and connect the cable to the BHS. (See [Powering the AP/SM/BH for test configuration](#) on Page 5-16)
- 3 Use stainless steel hose clamps or equivalent fasteners to lock the BHS into position.
- 4 Install a surge suppressor as described in the section [Mount the Surge Suppressor](#) on page 6-10
- 5 For coarse alignment of the BHS, use the Audible Alignment Tone feature as follows:
 - a. At the BHS, connect the RJ-45 connector of the Alignment Tool Headset to the Aux port via an alignment tone adapter as shown in [Figure 183](#) on page 8-19.
 - b. Listen to the alignment tone for pitch, which indicates greater signal power (RSSI/dBm) by higher pitch.
Adjust the module slightly until you hear the highest pitch and highest volume
- 6 When you have achieved the best signal (highest pitch, loudest volume), lock the BHS in place with the mounting hardware

Configuring the Link

See [Configuring remote access](#) on page 7-194.

Monitoring the Link

See [Monitoring the Link](#) on page 7-195.

Installing the AC Power Injector

**Caution**

As the PSU is not waterproof, locate it away from sources of moisture, either in the equipment building or in a ventilated moisture-proof enclosure. Do not locate the PSU in a position where it may exceed its temperature rating.

**Caution**

Do not plug any device other than a PMP/PTP 450i Series ODU into the ODU port of the PSU. Other devices may be damaged due to the non-standard techniques employed to inject DC power into the Ethernet connection between the PSU and the ODU.

Do not plug any device other than a Cambium 450 Platform PSU into the PSU port of the ODU. Plugging any other device into the PSU port of the ODU may damage the ODU and device.

Installing the AC Power Injector

Follow this procedure to install the AC Power Injector:

- 1 Form a drip loop on the PSU end of the LPU to PSU drop cable. The drip loop ensures that any moisture that runs down the cable cannot enter the PSU.
- 2 (a) Place the AC Power Injector on a horizontal surface. Plug the LPU to PSU drop cable into the PSU port labeled ODU. (b) When the system is ready for network connection, connect the network Cat5e cable to the LAN port of the PSU:

(a)



(b)



Installing CMM4

**Note**

For instructions on CMM3 (CMMmicro) or CMM4 installation, including the outdoor temperature range in which it is acceptable to install the unit, tools required, mounting and cabling instructions, and connectivity verification, please see the *PMP Synchronization Solutions User Guide* located on the Cambium website.

The Cluster Management Module 4 (CMM4) provides power, sync, and network connectivity for up to eight APs, backhauls, and Ethernet terrestrial feeds in a variety of configurations. The CMM4 provides

- Sync over Power over Ethernet and integrated surge suppression on the controller board for up to 8 APs or BHs. Both a custom 30 VDC power scheme and a custom 56 VDC power scheme are available. Neither is the same as the later IEEE Standard 802.3af, and neither is compatible with it.
- Managed switching using a hardened EtherWAN switch (1090CKHH models). The CMM4 ships with a 14-port EtherWAN switch and is also available without a switch. The CMM4 originally shipped with a 9-port EtherWAN switch.
- Surge suppression on the controller board for the incoming 30V DC and 56V DC power lines and GPS coax cable.
- Auto-negotiation on the Ethernet ports. Ports will auto-negotiate to match inputs that are either 100Base-T or 10Base-T, and either full duplex or half duplex, when the connected device is set to auto-negotiate. Alternatively, these parameters are settable.
- An always-on NTP (Network Time Protocol) server that can provide date and time to any radio that can reach the CMM's management IP address.
- CNUT can be used to upgrade the CMM-4 software.

450 Series and 450i Series can use the CMM4's EtherWan switch for their network connectivity.

**Note**

The 56 V of a CMM4 needs to go through the adapter cable (part number N000045L001A) as shown in [Figure 34](#) on page [2-52](#).

A CMM4 56V power adapter cable can be prepared by swapping pins 5 and 7. See [CMM4 56 V power adapter cable](#) pinout on page [2-52](#) for power adapter cable pinout.

Supplemental installation information

This section contains detailed installation procedures that are not included in the above topics, such as how to strip cables, create grounding points and weatherproof connectors.

Stripping drop cable

When preparing the drop cable for connection to the 450 Platform Family ODU or LPU, use the following measurements:

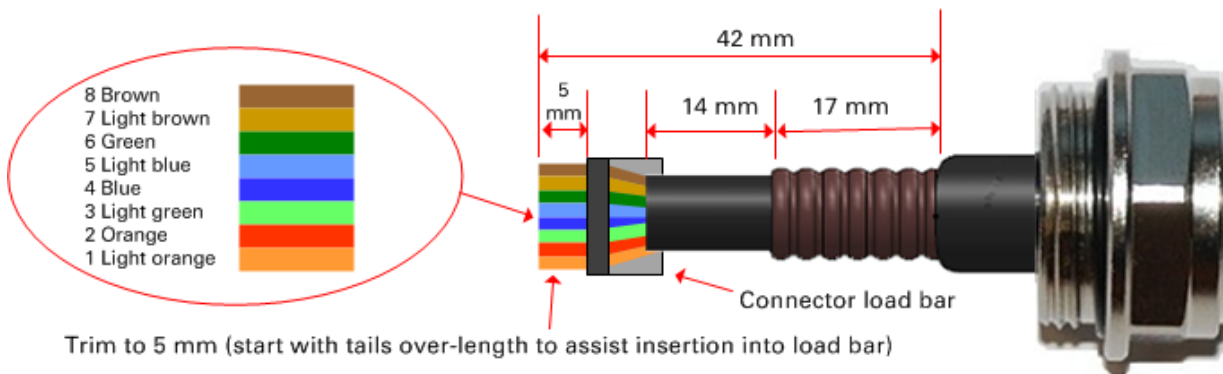

When preparing the drop cable for connection to the 450 Platform PSU (without a cable gland), use the following measurements:

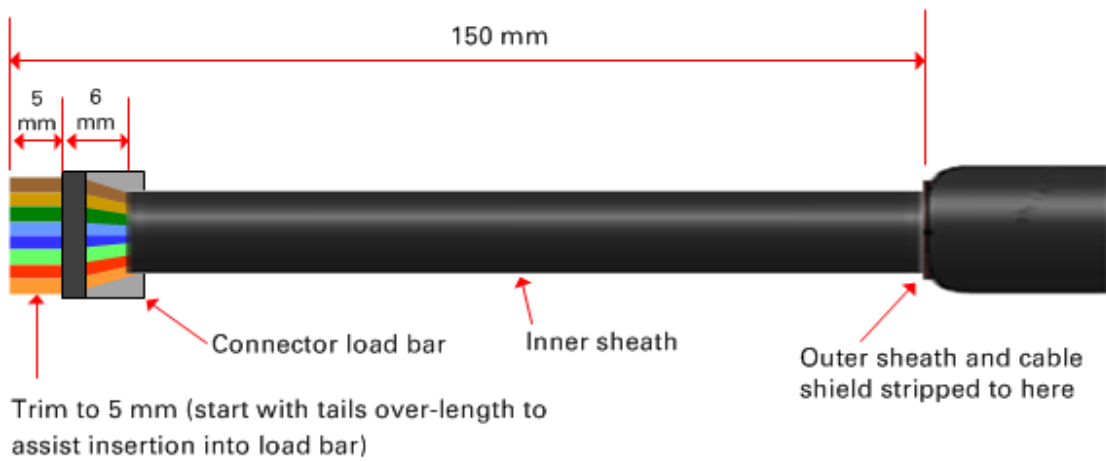

Creating a drop cable grounding point

Use this procedure to connect the screen of the main drop cable to the metal of the supporting structure using the cable grounding kit (Cambium part number 01010419001).

To identify suitable grounding points, refer to [Hazardous locations](#) on page 3-15.

- 1 Remove 60 mm (2.5 inches) of the drop cable outer sheath.



- 2 Cut 38mm (1.5 inches) of rubber tape (self-amalgamating) and fit to the ground cable lug. Wrap the tape completely around the lug and cable.



- 3 Fold the ground wire strap around the drop cable screen and fit cable ties.



- 4 Tighten the cable ties with pliers. Cut the surplus from the cable ties.



- 5 Cut a 38mm (1.5 inches) section of self-amalgamating tape and wrap it completely around the joint between the drop and ground cables.



- 6 Use the remainder of the self-amalgamating tape to wrap the complete assembly. Press the tape edges together so that there are no gaps.



- 7 Wrap a layer of PVC tape from bottom to top, starting from 25 mm (1 inch) below and finishing 25 mm (1 inch) above the edge of the self-amalgamating tape, overlapping at half width.



- 8 Repeat with a further four layers of PVC tape, always overlapping at half width. Wrap the layers in alternate directions (top to bottom, then bottom to top). The edges of each layer should be 25mm (1 inch) above (A) and 25 mm (1 inch) below (B) the previous layer.



- 9 Prepare the metal grounding point of the supporting structure to provide a good electrical contact with the grounding cable clamp. Remove paint, grease or dirt, if present. Apply anti-oxidant compound liberally between the two metals.
- 10 Clamp the bottom lug of the grounding cable to the supporting structure using site approved methods. Use a two-hole lug secured with fasteners in both holes. This provides better protection than a single-hole lug.

Attaching and weatherproofing an N type connector

The following procedure should be used to weatherproof the N type connectors fitted to the connectorized ODU (AP/SM/BH) and antenna. This procedure must be followed to ensure that there is no moisture ingress at the radio ports. Failure to properly seal N-type antenna connectors can result in poor link performance or complete loss of radio communication.

**Note**

Cambium recommends to assemble the antenna, attach the ODU and cabling, and to seal the RF connections before installing the unit at the deployment site.

**Note**

N type connectors should be tightened using a torque wrench, set to 15 lb in or 1.7 Nm. If a torque wrench is not available, N type connectors may be finger tightened.

Use this procedure to weatherproof the N type connectors fitted to the connectorized ODU and external antenna (if recommended by the antenna manufacturer).

- 1 Ensure the connection is tight. A torque wrench should be used if available:



- 2 Wrap the connection with a layer of 19 mm (0.75 inch) PVC tape, starting 25 mm (1 inch) below the connector body. Overlap the tape to half-width and extend the wrapping to the body of the LPU. Avoid making creases or wrinkles:



- 3** Smooth the tape edges:



- 4** Cut a 125mm (5 inches) length of rubber tape (self-amalgamating):

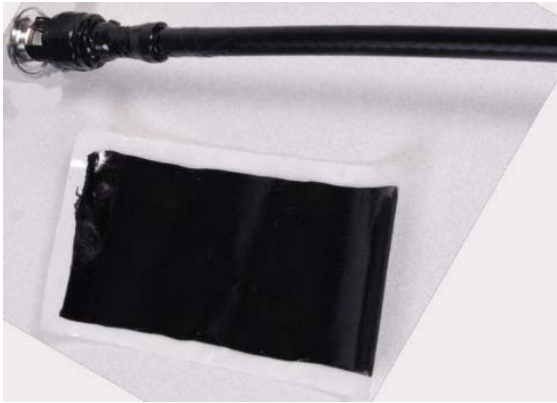

- 5** Expand the width of the tape by stretching it so that it will wrap completely around the connector and cable:



- 6** Press the tape edges together so that there are no gaps. The tape should extend 25 mm (1 inch) beyond the PVC tape:



- 7 Wrap a layer of 50 mm (2 inch) PVC tape from bottom to top, starting from 25 mm (1 inch) below the edge of the self-amalgamating tape, overlapping at half width.



- 8 Repeat with a further four layers of 19 mm (0.75 inch) PVC tape, always overlapping at half width. Wrap the layers in alternate directions:
- Second layer: top to bottom.
 - Third layer: bottom to top.
 - Fourth layer: top to bottom.
 - Fifth layer: bottom to top.

The bottom edge of each layer should be 25 mm (1 inch) below the previous layer.



- 9 Check the completed weatherproof connection:

**Note**

A video of this procedure can be found at:

<https://www.youtube.com/watch?v=a-twPfcVq4A>

Chapter 7: Configuration

This chapter describes how to use the web interface to configure the 450 Platform link. This chapter contains the following topics:

- [Preparing for configuration](#) on page 7-2
- [Connecting to the unit](#) on page 7-3
- [Using the web interface](#) on page 7-5
- [Quick link setup](#) on page 7-11
- [Configuring IP and Ethernet interfaces](#) on page 7-22
- [Upgrading the software version and using CNUT](#) on page 7-64
- [General configuration](#) on page 7-68
- [Configuring Unit Settings page](#) on page 7-91
- [Setting up time and date](#) on page 7-95
- [Configuring synchronization](#) on page 7-97
- [Configuring security](#) on page 7-99
- [Configuring radio parameters](#) on page 7-126
- [Setting up SNMP agent](#) on page 7-180
- [Configuring syslog](#) on page 7-188
- [Configuring remote access](#) on page 7-194
- [Monitoring the Link](#) on page 7-195
- [Configuring quality of service](#) on page 7-198
- [Installation Color Code](#) on page 7-211
- [Zero Touch Configuration Using DHCP Option 66](#) on page 7-212
- [Configuring Radio via config file](#) on page 7-218
- [Configuring a RADIUS server](#) on page 7-226

Preparing for configuration

This section describes the checks to be performed before proceeding with unit configuration and antenna alignment.

Safety precautions

All national and local safety standards must be followed while configuring the units and aligning the antennas.



Warning

Ensure that personnel are not exposed to unsafe levels of RF energy. The units start to radiate RF energy as soon as they are powered up. Respect the safety standards defined in Compliance with safety standards on page 4-22, in particular the minimum separation distances.

Observe the following guidelines:

- Never work in front of the antenna when the ODU is powered.
 - Always power down the PSU before connecting or disconnecting the drop cable from the PSU, ODU or LPU.
-

Regulatory compliance

All applicable radio regulations must be followed while configuring the units and aligning the antennas. For more information, refer to [Compliance with radio regulations](#) on page 4-34.



Caution

If the system designer has provided a list of channels to be barred for TDWR radar avoidance, the affected channels must be barred before the units are allowed to radiate on site, otherwise the regulations will be infringed.



Attention

Si le concepteur du système a fourni une liste de canaux à interdire pour éviter les radars TDWR, les canaux concernées doivent être interdits avant que les unités sont autorisées à émettre sur le site, sinon la réglementation peut être enfreinte.

Connecting to the unit

This section describes how to connect the unit to a management PC and power it up.

Configuring the management PC

Use this procedure to configure the local management PC to communicate with the 450 Platform ODU.

Procedure 9 Configuring the management PC

- 1 Select **Properties** for the Ethernet port. In Windows 7 this is found in **Control Panel > Network and Internet > Network Connections > Local Area Connection**.
- 2 Select **Internet Protocol (TCP/IP)**:

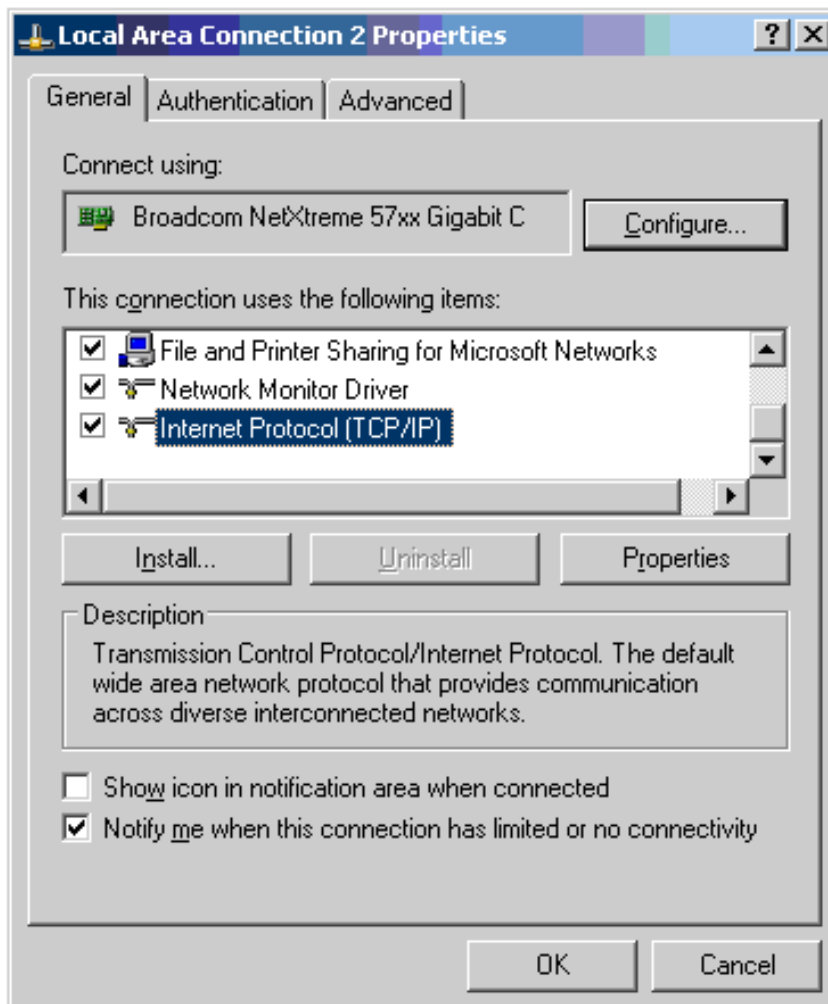

- 3 Click **Properties**.

- 4 Enter an IP address that is valid for the 169.254.X.X network, avoiding 169.254.0.0 and 169.254.1.1. A good example is 169.254.1.3:

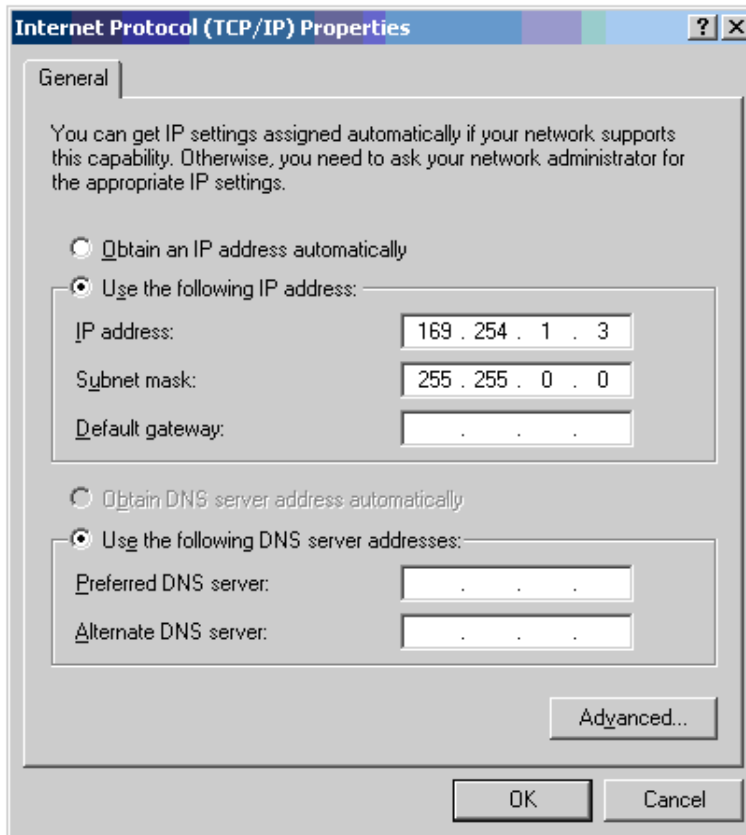

- 5 Enter a subnet mask of 255.255.0.0. Leave the default gateway blank.

Connecting to the PC and powering up

Use this procedure to connect a management PC and power up the 450 platform ODU.

Procedure 10 Connecting to the PC and powering up

- 1 Check that the ODU and PSU are correctly connected.
- 2 Connect the PC Ethernet port to the LAN port of the PSU using a standard (not crossed) Ethernet cable.
- 3 Apply mains or battery power to the PSU. The green Power LED should illuminate continuously.
- 4 After about several seconds, check that the orange Ethernet LED starts with 10 slow flashes.
- 5 Check that the Ethernet LED then illuminates continuously.

Using the web interface

This section describes how to log into the 450 Platform Family web interface and use its menus.

Logging into the web interface

Use this procedure to log into the web interface as a system administrator.

Procedure 11 Logging into the web interface

- 1 Start the web browser from the management PC.
- 2 Type the IP address of the unit into the address bar. The factory default IP address is **169.254.1.1**. Press ENTER. The web interface menu and System Summary page are displayed:

The screenshot shows the Cambium Networks web interface. On the left is a navigation menu with 'Home' and 'Copyright' links, a login form with 'Username:' and 'Password:' fields, a 'Login' button, and account details: 'Account: none', 'Level: GUEST', 'Mode: Read-Only'. The main content area is titled 'General Status' and shows 'Home → General Status' and '5.7GHz MIMO OFDM - Access Point 0a-00-3e-a1-35-49'. Below this are four expandable sections:

Device Information	
Device Type :	5.7GHz MIMO OFDM - Access Point - 0a-00-3e-a1-35-49
Board Type :	P12
Product Type :	PMP 450
Software Version :	CANOPY 15.0.1 AP-None
Board MSN :	6069PU00EZ
FPGA Version :	061716
PLD Version :	16
Uptime :	00:31:50
System Time :	09:18:17 11/10/2016 UTC
Main Ethernet Interface :	100Base-TX Full Duplex
Region Code :	United States
Regulatory :	Passed
Antenna Type :	External
Channel Frequency :	5760.0 MHz
Channel Bandwidth :	20.0 MHz
Cyclic Prefix :	1/16
Frame Period :	2.5 ms
Color Code :	87
Max Range :	40 Miles
Transmit Power :	19 dBm
Total Antenna Gain :	8 dBi (8 dBi external + 0 dBi internal)
Temperature :	35 °C / 94 °F

Access Point Stats	
Registered SM Count :	1 (2 Data VCs)
Sync Pulse Status :	Generating Sync
Sync Pulse Source :	Self Generate
Maximum Count of Registered SMs :	1

cnMaestro Connection Stats	
Connection Status :	Connected (cloud.cambiumnetworks.com)
AccountID :	CAMNWK

Site Information	
Site Name :	No Site Name
Site Contact :	No Site Contact
Site Location :	No Site Location

3 On left hand side of home page, the login information is displayed:

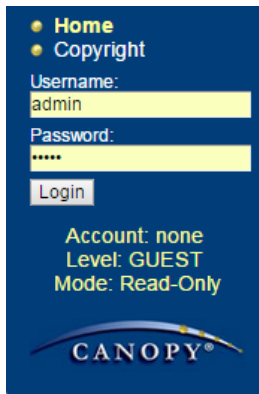

4 Enter Username (factory default username is *admin*) and Password (factory default password is *admin*) and click **Login**.

Web GUI

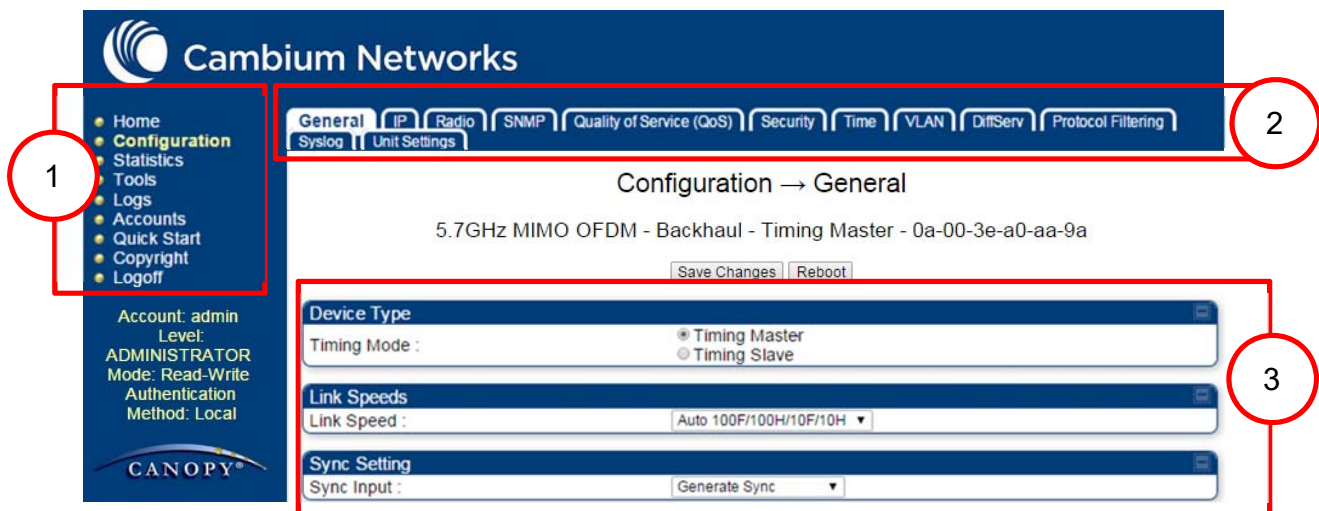

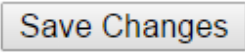
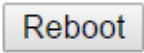
Field Name	Description
Main Menu	Click an option in side navigation bar (area marked as “1”). Multiple options in sub-navigation bars appear
Menu Option	Click top sub-navigation bar to choose one configuration page (area marked as “2”)
Parameter	To configure the parameters (e.g. area marked as “3”)
	Press "Save Changes" to confirm and save the changes
	To reboot the ODU

Using the menu options

Use the menu navigation bar in the left panel to navigate to each web page. Some of the menu options are only displayed for specific system configurations. Use [Table 101](#) to locate information about using each web page.



Table 101 Menu options and web pages

Main menu	Menu options	Applicable module	Description
	Home		
	General Status	All	Viewing General Status on page 9-2
	Session Status	AP, BHM	Viewing Session Status on page 9-20
	Event Log	All	Interpreting messages in the Event Log on page 9-29
	Network Interface	AP, BHM	Viewing the Network Interface on page 9-32
	Layer 2 Neighbors	All	Viewing the Layer 2 Neighbors on page 9-32
	Configuration		
	General	All	General configuration on page 7-68
	IP	All	Configuring IP and Ethernet interfaces on page 7-22
	Radio	All	Configuring radio parameters on page 7-127
	SNMP	All	Setting up SNMP agent on page 7-180
	cnMaestro	All	Configuring cnMaestro™ Connectivity on page 7-220
	Quality of Service (QoS)	All	Configuring quality of service on page 7-198
	Security	All	Configuring security on page 7-99
	Time	AP, BHM	Setting up time and date Time page of 450 Platform Family - AP/BHM on page 7-95

Main menu	Menu options	Applicable module	Description
	VLAN	All	VLAN configuration for PMP on page 7-43 VLAN configuration for PTP on page 7-53
	DiffServ	All	IPv4 and IPv6 Prioritization on page 7-60
	Protocol Filtering	All	Filtering protocols and ports on page 7-61
	Syslog	All	Configuring syslog on page 7-188
	Ping Watchdog	All	Configuring Ping Watchdog on page 7-267
	Unit Setting	All	Configuring Unit Settings page on page 7-91
	Statistics		
	Scheduler	All	Viewing the Scheduler statistics on page 9-33
	Registration Failures	AP, BHM	Viewing list of Registration Failures statistics on page 9-35
	Bridge Control Block	All	Interpreting Bridge Control Block statistics on page 9-19
	Bridging Table	All	Interpreting Bridging Table statistics on page 9-37
	Ethernet	All	Interpreting Ethernet statistics on page 9-38
	Radio	All	Interpreting RF Control Block statistics on page 9-41
	VLAN	All	Interpreting VLAN statistics on page 9-2
	Data VC	All	Interpreting Data VC statistics on page 9-4
	Throughput	AP, BHM	Interpreting Throughput statistics on page 9-6
	Filter	SM	Interpreting Filter statistics on page 9-12
	ARP	SM	Viewing ARP statistics on page 9-13
	Overload	All	Interpreting Overload statistics on page 9-9

Main menu	Menu options	Applicable module	Description
	Syslog Statistics	All	Interpreting syslog statistics on page 9-25
	Translation Table	SM	Interpreting Translation Table statistics on page 9-37
	DHCP Relay	SM	Interpreting DHCP Relay statistics on page 9-10
	NAT Stats	SM	Viewing NAT statistics on page 9-13
	NAT DHCP	SM	Viewing NAT DHCP Statistics on page 9-15
	Pass Through Statistics	AP	Interpreting Pass Through Statistics on page 9-22
	Sync Status	AP	Interpreting Sync Status statistics on page 9-16
	PPPoE	SM	Interpreting PPPoE Statistics for Customer Activities on page 9-17
	SNMPv3 Statistics	All	Interpreting SNMPv3 Statistics on page 9-23
	Frame Utilization		Interpreting Frame Utilization statistics on page 9-23
	Tools		
	Link Capacity Test	All	Using the Link Capacity Test tool on page 8-21
	Spectrum Analyzer	All	Spectrum Analyzer tool on page 8-3
	Remote Spectrum Analyzer	All	Remote Spectrum Analyzer tool on page 8-11
	AP/BHM Evaluation	SM, BHS	Using AP Evaluation tool on page 8-31 Using BHM Evaluation tool on page 8-35
	Subscriber Configuration	AP	Using the Subscriber Configuration tool on page 8-43
	OFDM Frame Calculator	AP, BHM	Using the OFDM Frame Calculator tool on page 8-39
	BER results	SM	Using BER Results tool on page 8-49
	Alignment Tool	SM, BHS	Using the Alignment Tool on page 8-14

Main menu	Menu options	Applicable module	Description
	Link Status	AP	Using the Link Status tool on page 8-44
	Sessions	AP	Using the Sessions tool on page 8-50
	Ping Test	All	Using the Ping Test tool on page 8-51
	• Logs		
	• Accounts		
	Change User Setting		Changing a User Setting on page 7-101
	Add user		Adding a User for Access to a module on page 7-100
	Delete User		Deleting a User from Access to a module on page 7-101
	User		Users account on page 7-102
	• Quick Start		
	Quick Start	AP, BHM	Quick link setup on page 7-11
	Region Settings	AP, BHM	Quick link setup on page 7-11
	Radio Carrier Frequency	AP, BHM	Quick link setup on page 7-11
	Synchronization	AP, BHM	Quick link setup on page 7-11
	LAN IP Address	AP, BHM	Quick link setup on page 7-11
	Review and Save Configuration	AP, BHM	Quick link setup on page 7-11
	• PDA		
	Quick Status	SM	The PDA web-page includes 320 x 240 pixel formatted displays of information important to installation and alignment for installers using legacy PDA devices. All device web pages are compatible with touch devices such as smart phones and tablets.
	Spectrum Results (PDA)	SM	
	Information	SM	
	BHM Evaluation	SM	
	AIM	SM	
	• Copyright		

Main menu	Menu options	Applicable module	Description
		All	The Copyright web-page displays pertinent device copyright information.
		All	

Quick link setup

This section describes how to use the Quick Start Wizard to complete the essential system configuration tasks that must be performed on a PMP/PTP configuration.



Note

If the IP address of the AP or BHM is not known, See [Radio recovery mode](#) on page 1-26.

Initiating Quick Start Wizard

Applicable products

PMP : AP

PTP: BHM

To start with Quick Start Wizard: after logging into the web management interface click the **Quick Start** button on the left side of main menu bar. The AP/BHM responds by opening the Quick Start page.

Figure 119 Disarm Installation page (top and bottom of page shown)

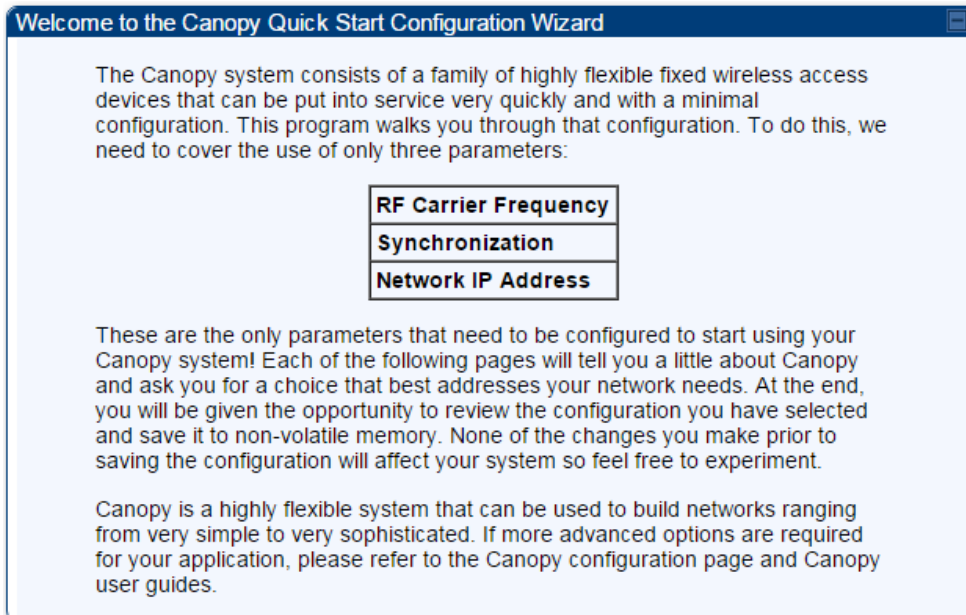

Quick Start is a wizard that helps you to perform a basic configuration that places an AP/BHM into service. Only the following parameters must be configured:

- Region Code
- RF Carrier Frequency
- Synchronization
- LAN (Network) IP Address

In each Quick Start page, you can

- specify the settings to satisfy the requirements of the network.
- review the configuration selected.

- save the configuration to non-volatile memory.

Procedure 12 Quick start wizard

- 1 At the bottom of the Quick Start tab, click the **Go To Next Page** button.
- 2 From the pull-down menu, select the region in which the AP will operate.

Figure 120 Regional Settings tab of AP/BHM

The screenshot displays the 'Regional Settings' configuration page. At the top, a blue header reads 'Region Settings Descriptions'. Below it, a text box explains that a region setting is required for international regulations and that the unit will not transmit without a valid region code. The main section, titled 'Region Settings', contains two dropdown menus: 'Region' set to 'Other - Regulatory' and 'Country' set to 'Other - FCC'. At the bottom, there are two buttons: '<=Go To Previous Page' and 'Go To Next Page=>'.

- 3 Click the **Go To Next Page** button.

- 4 From the pull-down menu, select a frequency for the test.

Figure 121 Radio Carrier Frequency tab of AP/BHM

Radio Carrier Frequency

To communicate, each Access Point (AP) and Backhaul (BH) timing master must be assigned a specific carrier frequency. By default, this frequency is not set at the factory to ensure that new units do not accidentally transmit on an unintended frequency. For our purposes, frequency selection for OFDM platforms has two basic rules:

1. Two radios located at a single location (such as an AP cluster) and on the same frequency should not have an overlapping pattern.
2. Generally for PMP 450, no guard band is needed. With the exception of 3.5/3.65 GHz platform, which can also operate with no guard band if "Adjacent Channel Support" is enabled. Otherwise 3.5/3.65 will need a guard band of 5/3/2 MHz for 20/10/5 MHz channel bandwidths. For PMP 430 and PTP 230, 5/5/2.5 MHz guard band is required for 20/10/5 MHz channels bandwidths.

We recommend multipoint AP clusters use frequencies separated by 15 MHz where convenient. For a 360 degree multipoint AP, each frequency is used twice with the back-to-back units sharing the same frequency.

Please see the Canopy User's Guide online for the latest information.

Direction of Access Point Radio	Frequency	Sector ID	Symbol
Northeast	5495 MHz	1	A
Southeast	5545 MHz	2	B
Southwest	5495 MHz	1	A
Northwest	5545 MHz	2	B

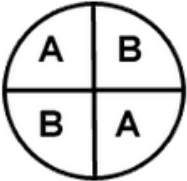

AP Carrier Frequency Parameter

Please select Carrier Frequency from the list : 5490.0 ▼

<=Go To Previous Page
Go To Next Page=>

- 5 Click the **Go To Next Page** button.

- 6 At the bottom of this tab, select **Generate Sync Signal**.

Figure 122 Synchronization tab of AP/BHM

Synchronization

When any radio transmits, it radiates energy. If a nearby radio is trying to receive at the same time another is transmitting, interference can result. One of the mechanisms used by Canopy to avoid this issue is to synchronize all transmissions. This approach ensures that all Canopy units will transmit and receive during the same time interval.

To accomplish this, Canopy Cluster Management Module's (CMM) each contain a GPS receiver. This receiver is used to create a precision timing signal which is then used by the attached APs/BHs (Backhauls). For systems that have only one AP/BH, this signal can be generated by selecting "Generate Sync" which causes AP/BH to use a simulated synchronization. For systems that have multiple APs/BHs, GPS synchronization should be used.

Each AP or BH timing master (BHM) must be programmed to either generate its own synchronization pulse (for single AP/BHM use only) or to use an external pulse. If you are using a CMM or other source of synchronization timing, you should select "AutoSync"; if not, you should select "Generate Sync". There are three methods on the AP/BHM from which the synchronization is received:

- 1)Power Port (Not applicable for PTP450)
- 2)Timing Port
- 3)On-board GPS (PMP 450 AP only)

If the power port is being used, only one cable is necessary to obtain power and the synchronization pulse. If the timing port is used, two cables will be necessary, one to obtain power and the other for the synchronization pulse.

Selecting "AutoSync + Free Run" will allow the AP/BHM to continue to transmit even after the sync pulse is lost. Otherwise if "AutoSync" is selected and synchronization pulse is lost, the AP/BHM will immediately stop transmitting. This is done to prevent interference with other Canopy systems.

Please be aware that operating multiple APs/BHs without an external GPS timing source may lead to degraded system operation.

Also, use the Frame Calculator tool for complete transmit and receive synchronization across different Canopy products.

Synchronization Parameters

Synchronization : Generate Sync ▼

<=Go To Previous Page
Go To Next Page=>

- 7 Click the **Go To Next Page** button.

- 8 At the bottom of the IP address configuration tab, either
- specify an **IP Address**, a **Subnet Mask**, and a **Gateway IP Address** for management of the AP and leave the **DHCP state** set to **Disabled**.
 - set the **DHCP state** to **Enabled** to have the IP address, subnet mask, and gateway IP address automatically configured by a domain name server (DNS).

Figure 123 LAN IP Address tab of the AP/BHM

LAN IP Address

The IP address of the Canopy AP/BH timing master is used to talk to the unit in order to monitor, update, and manage the Canopy system. If you are viewing this page (which you appear to be doing now), your browser is communicating with the Canopy AP/BH using this IP address.

Each network has its own collection of IP addresses that are used to route traffic between network elements such as APs, BHs, Routers, and Computers. You need to select the IP address, Default Gateway, and Network Mask which you intend to use to communicate with the AP/BH timing master in the space below.

If you don't know what these are, please consult your local network specialist.

LAN1 Network Interface Configuration

IP Address :	<input type="text" value="10.110.65.90"/>	
Subnet Mask :	<input type="text" value="255.255.255.0"/>	
Gateway IP Address :	<input type="text" value="10.110.65.254"/>	
DHCP state :	<input type="radio"/> Enabled <input checked="" type="radio"/> Disabled	
DHCP DNS IP Address :	<input checked="" type="radio"/> Obtain Automatically <input type="radio"/> Set Manually	
Preferred DNS Server :	<input type="text" value="10.110.12.31"/>	
Alternate DNS Server :	<input type="text" value="10.110.12.30"/>	
Domain Name :	<input type="text" value="pool.ntp.org"/>	



Note

Cambium encourages you to experiment with the interface. Unless you save a configuration and reboot the AP after you save the configuration, none of the changes are affected.

- 9 Click the **Go To Next Page =>** button.

- 10 Ensure that the initial parameters for the AP are set as you intended.

Figure 124 Review and Save Configuration tab of the AP/BHM

Review and Save Configuration

The parameters below reflect the selections you have made. From here, you may:

Change any parameter
Save the parameters to non-volatile memory
Undo all changes since the unit was last reset
Reset all settings to their factory default values
Reboot the Unit

It is important to know that no configuration changes you make to the Canopy unit will take effect until the unit is rebooted. Once you reboot, your Canopy unit is ready to go!

AP Carrier Frequency Parameter

Please select Carrier Frequency from the list : 5490.0 ▼

Region Settings

Region : Other - Regulatory ▼
 Country : Other ▼

Synchronization Parameters

Synchronization : Generate Sync ▼

LAN1 Network Interface Configuration

IP Address :	10.110.65.90
Subnet Mask :	255.255.255.0
Gateway IP Address :	10.110.65.254
DHCP state :	<input type="radio"/> Enabled <input checked="" type="radio"/> Disabled
DHCP DNS IP Address :	<input checked="" type="radio"/> Obtain Automatically <input type="radio"/> Set Manually
Preferred DNS Server :	10.110.12.31
Alternate DNS Server :	10.110.12.30
Domain Name :	pool.ntp.org

Unit-Wide Changes

Undo Unit-Wide Saved Changes
Set to Factory Defaults

<=Go To Previous Page
Save Changes
Reboot

- 11 Click the **Save Changes** button.

- 12 Click the **Reboot** button.

RESULT: The AP responds with the message **Reboot Has Been Initiated...**

- 13 Wait until the indicator LEDs are not red.
- 14 Trigger your browser to refresh the page until the AP redisplay the General Status tab.
- 15 Wait until the red indicator LEDs are not lit.

Configuring time settings

Applicable products PMP : AP PTP: BHM

To proceed with the test setup, click the **Configuration** link on the left side of the General Status page. When the AP responds by opening the Configuration page to the General page, click the Time tab.

Figure 125 Time tab of the AP/BHM

The screenshot displays the 'Time' configuration page with the following sections:

- NTP Server Configuration:** Includes radio buttons for 'Append DNS Domain Name' and 'Disable DNS Domain Name' (selected). Below are input fields for NTP Server 1, 2, and 3, all containing '0.0.0.0'. A status line reads 'No NTP Server Configured' with a 'Get Time via NTP' button below it.
- Current System Time:** Shows 'Time Zone' as 'UTC: (UTC) Coordinated Universal Time', 'System Time' as '01:55:25 01/01/2011 UTC', and 'Last NTP Time Update' as '00:00:00 00/00/0000 UTC'.
- Time and Date:** Shows 'Time' as '01 : 55 : 21 UTC' and 'Date' as '01 / 01 / 2011', with a 'Set Time and Date' button.
- NTP Update Log:** Displays 'No entries.'

To have each log in the AP/BHM correlated to a meaningful time and date, either a reliable network element must pass time and date to the AP/BHM or you must set the time and date whenever a power cycle of the AP/BHM has occurred. A network element passes time and date in any of the following scenarios:

- A connected CMM4 passes time and date (GPS time and date, if received).
- A separate NTP server is addressable from the AP/BHM.

If the AP/BHM should obtain time and date from a CMM4, or a separate NTP server, enter the IP address of the CMM4 or NTP server on this tab. To force the AP/BHM to obtain time and date before the first (or next) 15-minute interval query of the NTP server, click **Get Time through NTP**.

If you enter a time and date, the format for entry is

Figure 126 Time and date entry formats

Time : / /
 Date : / /

where

- hh** represents the two-digit hour in the range 00 to 24
- mm** represents the two-digit minute
- ss** represents the two-digit second
- MM** represents the two-digit month
- dd** represents the two-digit day
- yyyy** represents the four-digit year

Proceed with the time setup as follows.

Procedure 13 Entering AP/BHM time setup information

- 1 Enter the appropriate information in the format shown above.
- 2 Then click the **Set Time and Date** button.



Note

The time displayed at the top of this page is static unless your browser is set to automatically refresh

Powering the SM/BHS for test

Procedure 14 Powering the SM/BHS for test

- 1 In one hand, securely hold the top (larger shell) of the SM/BHS. With the other hand, depress the lever in the back of the base cover (smaller shell). Remove the base cover.
- 2 Plug one end of a CAT 5 Ethernet cable into the SM PSU port
- 3 Plug the other end of the Ethernet cable into the jack in the pig tail that hangs from the power supply
- 4 Roughly aim the SM/BHS toward the AP/BHM
- 5 Plug the power supply into an electrical outlet



Warning

From this point until you remove power from the AP/BHM, stay at least as far from the AP/BHM as the minimum separation distance specified in [Calculated distances and power compliance margins](#).

- 6 Repeat the foregoing steps for each SM/BHS that you wish to include in the test.

Viewing the Session Status of the AP/BHM to determine test registration

Once the SMs/BHS under test are powered on, return to the computing device to determine if the SM/BHS units have registered to the AP/BHM.



Note

In order for accurate power level readings to be displayed, traffic must be present on the radio link.

The Session Status tab provides information about each SM/BHS that has registered to the AP/BHM. This information is useful for managing and troubleshooting a system. All information that you have entered in the **Site Name** field of the SM/BHS displays in the Session Status tab of the linked AP/BHM. The Session Status tab also includes the current active values on each SM(or BHS) (LUID) for MIR, and VLAN, as well as the source of these values (representing the SM/BHS itself, Authentication Server, or the AP/BHM and cap, if any—for example, APCAP as shown above).. As an SM/BHS registers to the AP/BHM, the configuration source that this page displays for the associated LUID may change. After registration, however, the displayed source is stable and can be trusted.

Idle subscribers may be included or removed from the session status display by enabling or disabling, respectively, the **Show Idle Sessions** parameter. Enabling or disabling this parameter only affects the GUI display of subscribers, not the registration status.

The SessionStatus.xml hyperlink allows user to export session status page from web management interface of AP/BHM. The session status page will be exported in xml file.

Procedure 15 Viewing the AP Session Status page

- 1 On the AP web management GUI, navigate to **Home, Session Status:**

Figure 127 Session Status tab of AP

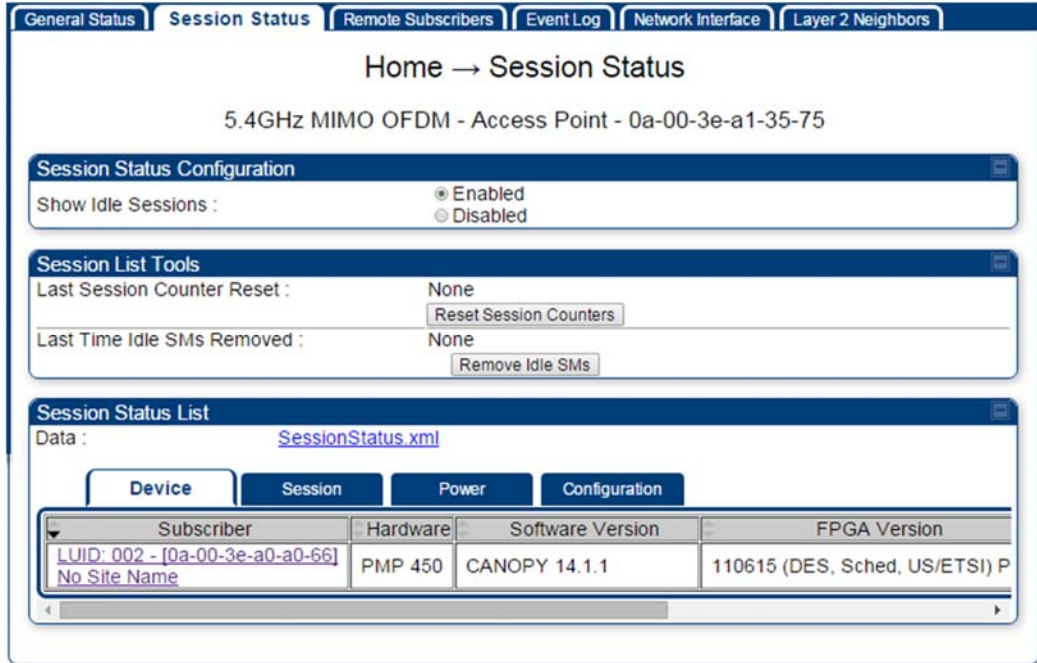

Note

Session status page for BHM is same as AP.

- 2 Verify that for each SM (or BHS) MAC address (printed on the SM/BHS housing) the AP/BHM has established a registered session by verifying the “State” status of each entry.

The Session Status page of the AP/BHM is explained in [Table 102](#).

Table 102 Session Status Attributes – AP

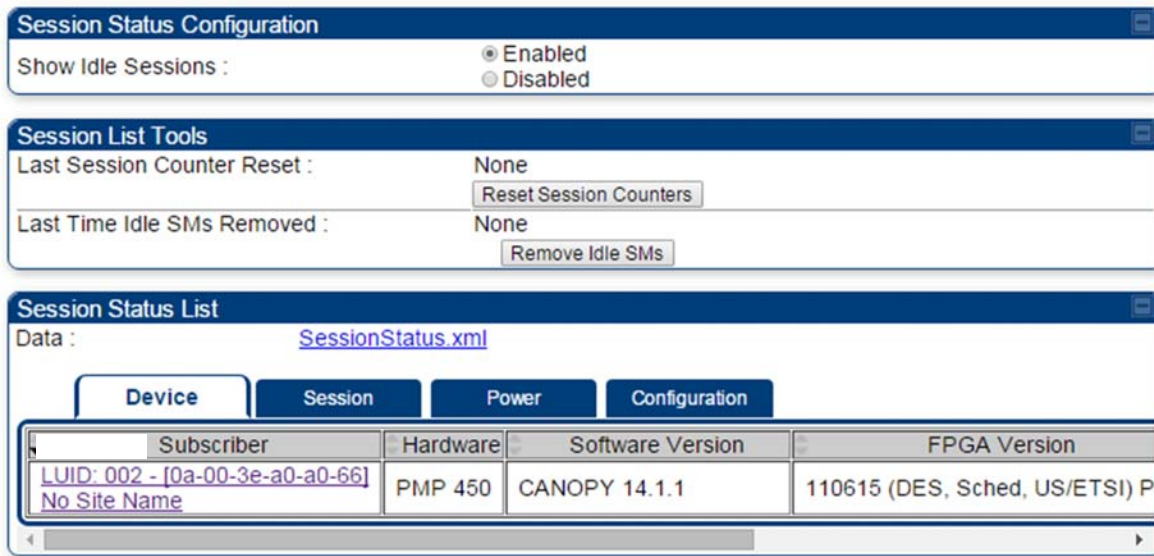

Attribute	Meaning
Show Idle Sessions	Idle subscribers may be included or removed from the session status display by enabling or disabling, respectively, the Show Idle Sessions parameter. Enabling or disabling this parameter only affects the GUI display of subscribers, not the registration status.
Last Session Counter Reset	This field displays date and time stamp of last session counter reset.
Last Time Idle SMs Removed	This field displays date and time stamp of last Idle SMs Removed. On click of "Remove Idle SMs" button, all the SMs which are in Idle state are flushed out.
Data	See Exporting Session Status page of AP/BHM on page 7-209
Device tab	See Device tab on page 9-20
Session tab	See Session tab on page 9-21
Power tab	See Power tab on page 9-23
Configuration tab	See Configuration tab on page 9-25

Configuring IP and Ethernet interfaces

This task consists of the following sections:

- [Configuring the IP interface](#) on page 7-23
- [Auxiliary port](#) on page 7-26
- [NAT, DHCP Server, DHCP Client and DMZ](#) on page 7-27
- [IP interface with NAT disabled](#) on page 7-32
- [IP interface with NAT enabled](#) on page
- [NAT tab with NAT disabled](#) on page 7-35
- [NAT tab with NAT enabled](#) on page 7-37
- [NAT DNS Considerations](#) on page 7-42
- [DHCP – BHS](#) on page 7-43
- [VLAN configuration for PMP](#) on page 7-43
- [VLAN page of AP](#) on page 7-46
- [VLAN page of SM](#) on page 7-49
- [VLAN Membership tab of SM](#) on page 7-53
- [VLAN configuration for PTP](#) on page 7-53
- [NAT Port Mapping tab - SM](#) on page 7-42

Configuring the IP interface

The IP interface allows users to connect to the 450 Platform Family web interface, either from a locally connected computer or from a management network.

Applicable products **PMP :** AP SM **PTP:** BHM BMS

To configure the IP interface, follow these instructions:

Procedure 16 Configuring the AP/BHM IP interface

- 1 Select menu option **Configuration > IP**. The LAN configuration page is displayed:

LAN1 Network Interface Configuration	
IP Address :	169.254.1.1
Subnet Mask :	255.255.0.0
Gateway IP Address :	169.254.0.0
DHCP state :	<input type="radio"/> Enabled <input checked="" type="radio"/> Disabled
DNS IP Address :	<input checked="" type="radio"/> Obtain Automatically <input type="radio"/> Set Manually
Preferred DNS Server :	0.0.0.0
Alternate DNS Server :	0.0.0.0
Domain Name :	example.com

- 2 Update IP Address, Subnet Mask and Gateway IP Address to meet network requirements (as specified by the network administrator).
- 3 Review the other IP interface attributes and update them, if necessary (see Table 103 IP interface attributes).
- 4 Click **Save**. “Reboot Required” message is displayed:

LAN1 Network Interface Configuration	
IP Address :	169.254.1.2
Subnet Mask :	255.255.0.0
Gateway IP Address :	169.254.0.0
DHCP state :	<input type="radio"/> Enabled <input checked="" type="radio"/> Disabled
DNS IP Address :	<input checked="" type="radio"/> Obtain Automatically <input type="radio"/> Set Manually
Preferred DNS Server :	0.0.0.0
Alternate DNS Server :	0.0.0.0
Domain Name :	example.com

- 5 Click **Reboot**.

The IP page of AP/SM/BHM/BHS is explained in [Table 103](#).

Table 103 IP interface attributes

LAN1 Network Interface Configuration

IP Address :	<input type="text" value="10.110.245.135"/>
Subnet Mask :	<input type="text" value="255.255.255.0"/>
Gateway IP Address :	<input type="text" value="10.110.245.254"/>
DHCP state :	<input type="radio"/> Enabled <input checked="" type="radio"/> Disabled
DHCP DNS IP Address :	<input checked="" type="radio"/> Obtain Automatically <input type="radio"/> Set Manually
Preferred DNS Server :	<input type="text" value="10.110.12.30"/>
Alternate DNS Server :	<input type="text" value="10.110.12.31"/>
Domain Name :	<input type="text" value="example.com"/>

Advanced LAN1 IP Configuration

Default alternative LAN1 IP address :	<input type="radio"/> Enabled <input checked="" type="radio"/> Disabled
---------------------------------------	--

Aux Ethernet Port

AUX Ethernet Port :	<input type="radio"/> Enabled <input checked="" type="radio"/> Disabled
AUX Ethernet Port PoE :	<input type="radio"/> Enabled <input checked="" type="radio"/> Disabled <input type="button" value="Reset AUX PoE"/>

LAN2 Network Interface Configuration (Radio Private Interface - Must end in .1)

IP Address :	<input type="text" value="192.168.101.1"/>
--------------	--

Attribute	Meaning
IP Address	Internet Protocol (IP) address. This address is used by family of Internet protocols to uniquely identify this unit on a network.
Subnet Mask	Defines the address range of the connected IP network.
Gateway IP Address	The IP address of a computer on the current network that acts as a gateway. A gateway acts as an entrance and exit to packets from and to other networks.
DHCP state	If Enabled is selected, the DHCP server automatically assigns the IP configuration (IP address, subnet mask, and gateway IP address) and the values of those individual parameters (above) are not used. The setting of this DHCP state parameter is also viewable (read only), in the Network Interface tab of the Home page.
DNS IP Address	Canopy devices allow for configuration of a preferred and alternate DNS server IP address either automatically or manually. Devices must set DNS server IP address manually when DHCP is disabled for the management

	interface of the device. DNS servers may be configured automatically from the DHCP response when DHCP is enabled for the management interface of the device. Optionally devices may be configured to set the DNS server IP address manually when DHCP is enabled for the management interface. The default DNS IP addresses are 0.0.0.0 when configured manually.
Preferred DNS Server	The first address used for DNS resolution.
Alternate DNS Server	If the Preferred DNS server cannot be reached, the Alternate DNS Server is used.
Domain Name	The operator's management domain name may be configured for DNS. The domain name configuration can be used for configuration of the servers in the operator's network. The default domain name is example.com, and is only used if configured as such.
Advanced LAN1 IP Configuration – Default alternate LAN1 IP address	Hardcoded default alternate IP address (169.254.1.1) that is available only when connected to the Ethernet port. When enabled, user can configure a second IP address for the bridge which is other than the hardcoded IP address (169.254.1.1).
AUX Ethernet Port – AUX Ethernet Port	Enabled: Data is enabled for Auxiliary port Disabled: Data is disabled for Auxiliary port
AUX Ethernet Port – AUX Ethernet Port PoE	Enabled: PoE out is enable for Auxiliary port Disabled: PoE out is disabled for Auxiliary port
LAN2 Network Interface Configuration (Radio Private Interface) – IP Address	It is recommended not to change this parameter from the default AP/BHM private IP address of 192.168.101.1. A /24 CIDR subnet is used to communicate with each of the SMs/BHS that are registered. The AP/BHM uses a combination of the private IP and the LUID (logical unit ID) of the SM/BHS. It is only displayed for AP and BHM.

Table 104 SM/BHS private IP and LUID

SM/BHS	LUID	Private IP
First SM/BHS registered	2	192.168.101.2
Second SM/BHS registered	3	192.168.101.3

Auxiliary port

An additional Ethernet port labeled “Aux” for Auxiliary port is implemented for downstream traffic. This feature is supported only for PTP/PMP 450i ODU.

To enable the Aux port, follow these instructions:

Procedure 17 Enabling Aux port interface

- 1 Select menu option **Configuration > IP > Aux Network Interface** tab.:



- 2 Click Enable button of Aux Ethernet Port parameter to enable Aux Ethernet port
- 3 Click Enable button of Aux Ethernet Port PoE parameter to enable Aux port PoE out.
- 4 Click **Save**. “Reboot Required” message is displayed.
- 5 Click **Reboot**.

Table 105 Aux port attributes



Attribute	Meaning
Aux Ethernet Port	Enabled: Data is enabled for Auxiliary port Disabled: Data is disabled for Auxiliary port
Aux Ethernet Port PoE	Enabled: PoE out is enable for Auxiliary port Disabled: PoE out is disabled for Auxiliary port

By disabling this feature, the data at the Auxiliary port will be disabled.

NAT, DHCP Server, DHCP Client and DMZ

Applicable products	PMP :	<input checked="" type="checkbox"/> SM
----------------------------	--------------	--

The system provides NAT (Network Address Translation) for SMs in the following combinations of NAT and DHCP (Dynamic Host Configuration Protocol):

- NAT Disabled
- NAT with DHCP Client (**DHCP** selected as the **Connection Type** of the WAN interface) and DHCP Server
- NAT with DHCP Client(**DHCP** selected as the **Connection Type** of the WAN interface)
- NAT with DHCP Server
- NAT without DHCP

NAT

NAT isolates devices connected to the Ethernet or wired side of a SM from being seen directly from the wireless side of the SM. With NAT enabled, the SM has an IP address for transport traffic (separate from its address for management), terminates transport traffic and allows you to assign a range of IP addresses to devices that are connected to the Ethernet or wired side of the SM.

In the Cambium system, NAT supports many protocols, including HTTP, ICMP (Internet Control Message Protocols), and FTP (File Transfer Protocol). For virtual private network (VPN) implementation, L2TP over IPsec (Level 2 Tunneling Protocol over IP Security) and PPTP (Point to Point Tunneling Protocol) are supported.



Note

When NAT is enabled, a reduction in throughput is introduced in the system (due to processing overhead).

DHCP

DHCP enables a device to be assigned a new IP address and TCP/IP parameters, including a default gateway, whenever the device reboots. Thus DHCP reduces configuration time, conserves IP addresses, and allows modules to be moved to a different network within the Cambium system.

In conjunction with the NAT features, each SM provides the following:

- A DHCP server that assigns IP addresses to computers connected to the SM by Ethernet protocol.
- A DHCP client that receives an IP address for the SM from a network DHCP server.

DMZ

In conjunction with the NAT features, a DMZ (Demilitarized Zone) allows the allotment of one IP address behind the SM for a device to logically exist outside the firewall and receive network traffic. The first three octets of this IP address must be identical to the first three octets of the NAT private IP address.

- A DHCP server that assigns IP addresses to computers connected to the SM by Ethernet protocol.
- A DHCP client that receives an IP address for the SM from a network DHCP server.

NAT Disabled

The NAT Disabled implementation is illustrated in [Figure 128](#).

Figure 128 NAT disabled implementation

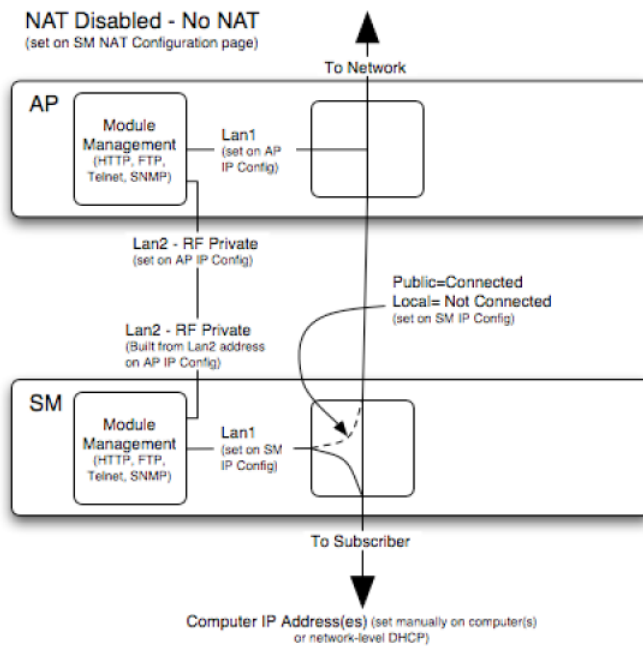

NAT with DHCP Client and DHCP Server

The NAT with DHCP Client and DHCP server is illustrated in [Figure 129](#).

Figure 129 NAT with DHCP client and DHCP server implementation

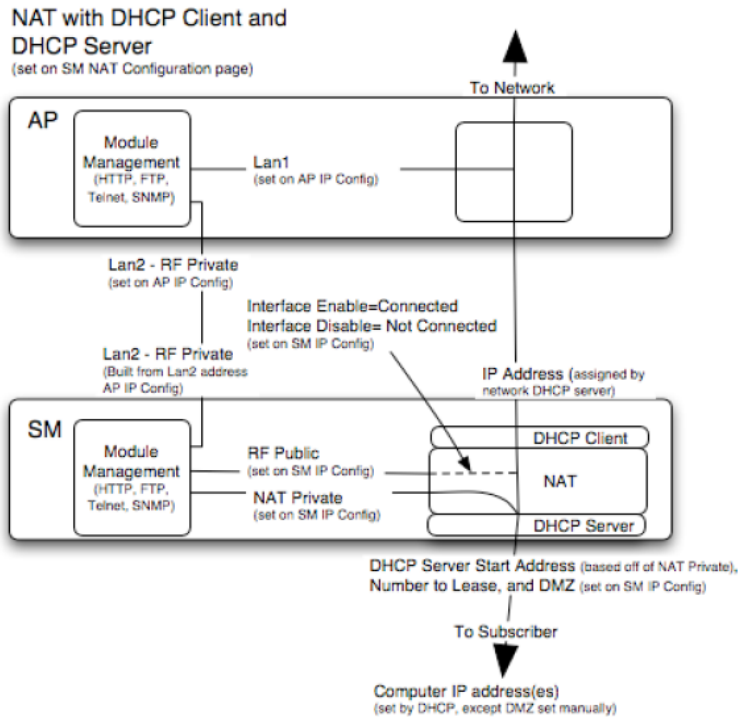

NAT with DHCP Client

Figure 130 NAT with DHCP client implementation

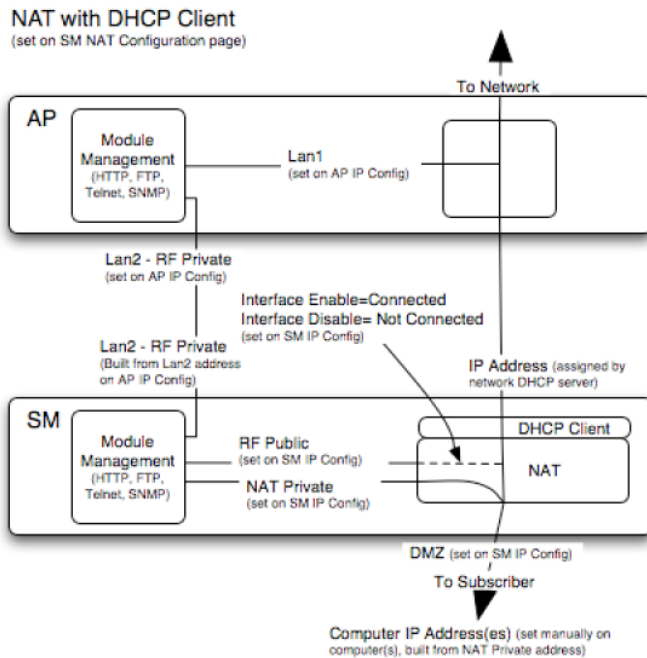

NAT with DHCP Server

Figure 131 NAT with DHCP server implementation

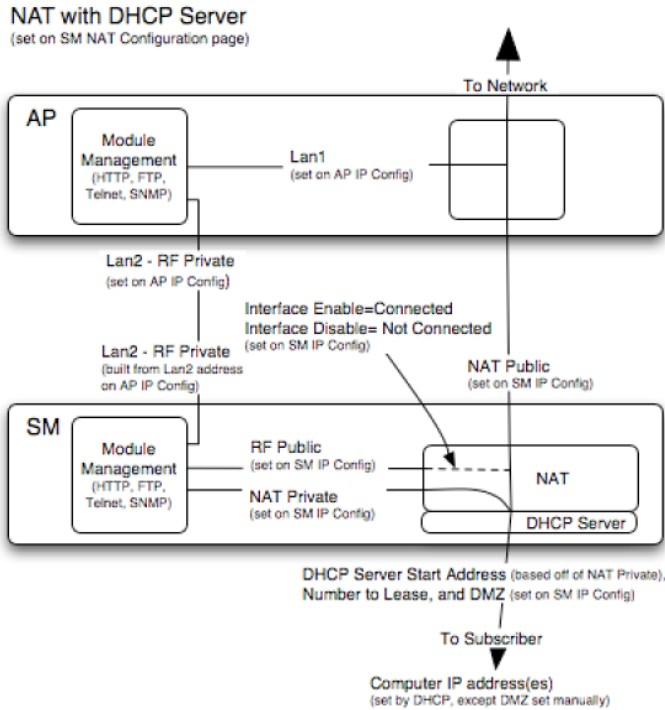

NAT without DHCP

Figure 132 NAT without DHCP implementation

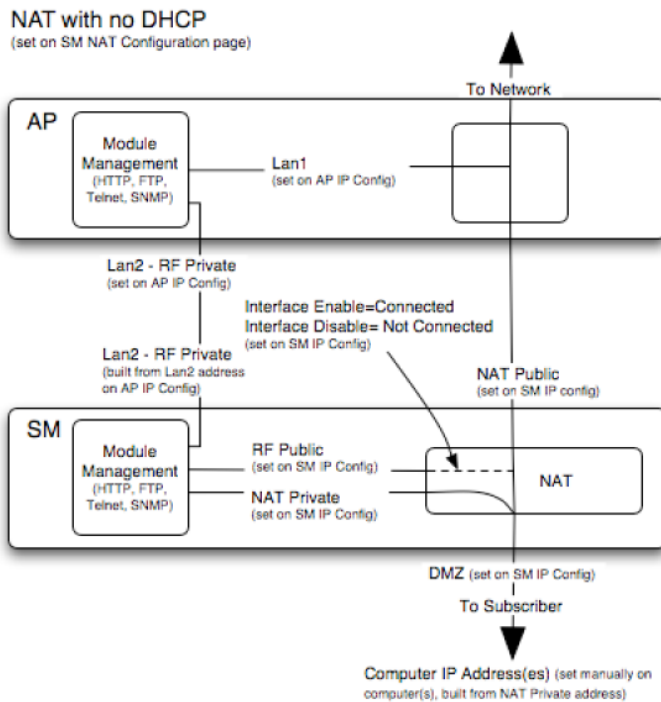

NAT and VPNs

VPN technology provides the benefits of a private network during communication over a public network. One typical use of a VPN is to connect employees remotely (who are at home or in a different city), with their corporate network through a public Internet. Any of several VPN implementation schemes is possible. By design, NAT translates or changes addresses, and thus interferes with a VPN that is not specifically supported by a given NAT implementation.

With NAT enabled, SM supports L2TP over IPSec (Level 2 Tunneling Protocol over IP Security) VPNs and PPTP (Point to Point Tunneling Protocol) VPNs. With NAT disabled, SM supports all types of VPNs.

IP interface with NAT disabled - SM

The IP page of SM with NAT disabled is explained in [Table 106](#).

Table 106 IP attributes - SM with NAT disabled

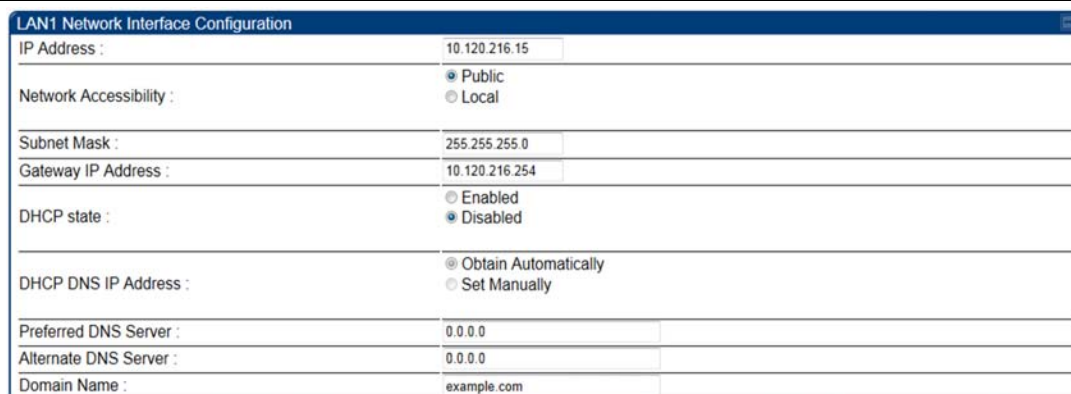

LAN1 Network Interface Configuration	
IP Address :	10.120.216.15
Network Accessibility :	<input checked="" type="radio"/> Public <input type="radio"/> Local
Subnet Mask :	255.255.255.0
Gateway IP Address :	10.120.216.254
DHCP state :	<input type="radio"/> Enabled <input checked="" type="radio"/> Disabled
DHCP DNS IP Address :	<input checked="" type="radio"/> Obtain Automatically <input type="radio"/> Set Manually
Preferred DNS Server :	0.0.0.0
Alternate DNS Server :	0.0.0.0
Domain Name :	example.com

Attribute	Meaning
IP Address	<p>Enter the non-routable IP address to associate with the Ethernet connection on this SM. (The default IP address from the factory is 169.254.1.1.) If you forget this parameter, you must both:</p> <ul style="list-style-type: none"> physically access the module. use recovery mode to access the module configuration parameters at 169.254.1.1. See Radio recovery mode on page 1-26
	<p> Note</p> <p>Note or print the IP settings from this page. Ensure that you can readily associate these IP settings both with the module and with the other data that you store about the module.</p>
Network Accessibility	Specify whether the IP address of the SM must be visible to only a device connected to the SM by Ethernet (Local) or be visible to the AP/BHM as well (Public).
Subnet Mask	Enter an appropriate subnet mask for the SM to communicate on the network. The default subnet mask is 255.255.0.0.
Gateway IP Address	Enter the appropriate gateway for the SM to communicate with the network. The default gateway is 169.254.0.0.
DHCP state	<p>If you select Enabled, the DHCP server automatically assigns the IP configuration (IP address, subnet mask, and gateway IP address) and the values of those individual parameters (above) are not used. The setting of this DHCP state parameter is also viewable, but not settable, in the Network Interface tab of the Home page.</p> <p>In this tab, DHCP State is settable only if the Network Accessibility parameter in the IP tab is set to Public. This parameter is also settable in the NAT tab of the Configuration web page, but only when NAT is enabled.</p>

If the **DHCP state** parameter is set to **Enabled** in the **Configuration > IP** sub-menu of the SM/BHS, do not check the **BootpClient** option for **Packet Filter Types** in its Protocol Filtering tab, because doing so can block the DHCP request. (Filters apply to all packets that leave the SM via its RF interface, including those that the SM itself generates.) If you want to keep DHCP enabled and avoid the blocking scenario, select the **Bootp Server** option instead. This will result in responses being appropriately filtered and discarded.

DHCP DNS IP Address	Canopy devices allow for configuration of a preferred and alternate DNS server IP address either automatically or manually. Devices must set DNS server IP address manually when DHCP is disabled for the management interface of the device. DNS servers may be configured automatically from the DHCP response when DHCP is enabled for the management interface of the device. Optionally devices may be configured to set the DNS server IP address manually when DHCP is enabled for the management interface. The default DNS IP addresses are 0.0.0.0 when configured manually.
---------------------	--

Preferred DNS Server	The first DNS server used for DNS resolution.
----------------------	---

Alternate DNS Server	The second DNS server used for DNS resolution.
----------------------	--

Domain Name	The operator's management domain name may be configured for DNS. The domain name configuration can be used for configuration of the servers in the operator's network. The default domain name is example.com, and is only used if configured as such.
-------------	--

IP interface with NAT enabled - SM

The IP page of SM with NAT enabled is explained in [Table 107](#).

Table 107 IP attributes - SM with NAT enabled



The screenshot shows a configuration window titled "NAT Network Interface Configuration". It contains two input fields: "IP Address" with the value "169.254.1.1" and "Subnet Mask" with the value "255.255.255.0".

Attribute	Meaning
IP Address	Assign an IP address for SM/BHS management through Ethernet access to the SM/BHS. Set only the first three bytes. The last byte is permanently set to 1. This address becomes the base for the range of DHCP-assigned addresses.
Subnet Mask	Assign a subnet mask of 255.255.255.0 or a more restrictive subnet mask. Set only the last byte of this subnet mask. Each of the first three bytes is permanently set to 255.

NAT tab with NAT disabled - SM

The NAT tab of SM with NAT disabled is explained in [Table 108](#).

Table 108 NAT attributes - SM with NAT disabled

NAT Enable	
NAT Enable/Disable :	<input type="radio"/> Enabled <input checked="" type="radio"/> Disabled
Save Changes	
WAN Interface	
Connection Type :	DHCP
IP Address :	0.0.0.0
Subnet Mask :	255.255.255.0
Gateway IP Address :	0.0.0.0
Reply to Ping on WAN Interface :	<input type="radio"/> Enabled <input checked="" type="radio"/> Disabled
LAN Interface	
IP Address :	10.120.216.19
Subnet Mask :	255.255.255.xxx
DMZ Enable :	<input type="radio"/> Enabled <input checked="" type="radio"/> Disabled
DMZ IP Address :	xxx.xxx.xxx.52
LAN DHCP Server	
DHCP Server Enable/Disable :	<input checked="" type="radio"/> Enabled <input type="radio"/> Disabled
DHCP Server Lease Timeout :	30 Days (Range : 1 — 30)
DHCP Start IP :	xxx.xxx.xxx.2
Number of IP's to Lease :	50
DNS Server Proxy :	<input type="radio"/> Enabled <input checked="" type="radio"/> Disabled
DNS IP Address :	<input checked="" type="radio"/> Obtain Automatically (From WAN DHCP or PPPoE) <input type="radio"/> Set Manually
Preferred DNS IP Address :	0.0.0.0
Alternate DNS IP Address :	0.0.0.0
Remote Configuration Interface	
Remote Management Interface :	Disable
Connection Type :	<input type="radio"/> DHCP <input checked="" type="radio"/> Static IP
IP Address :	0.0.0.0
Subnet Mask :	255.255.255.0
Gateway IP Address :	0.0.0.0
DHCP DNS IP Address :	<input checked="" type="radio"/> Obtain Automatically <input type="radio"/> Set Manually
Preferred DNS Server :	0.0.0.0
Alternate DNS Server :	0.0.0.0
Domain Name :	example.com
NAT Protocol Parameters	
ARP Cache Timeout :	20 Minutes (Range : 1 — 30)
TCP Session Garbage Timeout :	120 Minutes (Range : 4 — 1440)
UDP Session Garbage Timeout :	4 Minutes (Range : 1 — 1440)
Translation Table Size :	2048 Translations (Range : 1024 — 8192)

Attribute	Meaning
NAT Enable/Disable	<p>This parameter enables or disables the Network Address Translation (NAT) feature for the SM. NAT isolates devices connected to the Ethernet or wired side of a SM from being seen directly from the wireless side of the SM. With NAT enabled, the SM has an IP address for transport traffic separate from its address for management, terminates transport traffic, and allows you to assign a range of IP addresses to devices that are connected to the Ethernet or wired side of the SM.</p> <p>When NAT is enabled, VLANs are not supported on the wired side of that SM. You can enable NAT in SMs within a sector where VLAN is enabled in the AP/BHM, but this may constrain network design.</p>
IP Address	This field displays the IP address for the SM. DHCP Server <i>will not</i> automatically assign this address when NAT is disabled.
Subnet Mask	This field displays the subnet mask for the SM. DHCP Server <i>will not</i> automatically assign this address when NAT is disabled.
Gateway IP Address	This field displays the gateway IP address for the SM. DHCP Server <i>will not</i> automatically assign this address when NAT is disabled.
ARP Cache Timeout	If a router upstream has an ARP cache of longer duration (as some use 30 minutes), enter a value of longer duration than the router ARP cache. The default value of this field is 20 minutes.
TCP Session Garbage Timeout	Where a large network exists behind the SM, you can set this parameter to lower than the default value of 120 minutes. This action makes additional resources available for greater traffic than the default value accommodates.
UDP Session Garbage Timeout	You may adjust this parameter in the range of 1 to 1440 minutes, based on network performance. The default value of this parameter is 4 minutes.
Translation Table Size	Total number of minutes that have elapsed since the last packet transfer between the connected device and the SM/BHS.

**Note**

When NAT is disabled, the following parameters are not required to be configurable:

WAN Interface > Connection Type, IP Address, Subnet Mask, Gateway IP address

LAN Interface > IP Address

LAN DHCP Server > DHCP Server Enable/Disable, DHCP Server Lease Timeout, Number of IP's to Lease, DNS Server Proxy, DNS IP Address, Preferred DNS IP address, Alternate DNS IP address

Remote Management Interface > Remote Management Interface, IP address, Subnet Mask, DHCP DNS IP Address, Preferred DNS Server, Alternate DNS Server, Domain Name

NAT Protocol Parameters > ARP Cache Timeout, TCP Session Garbage Timeout, UDP Session Garbage Timeout, Translation Table Size

NAT tab with NAT enabled - SM



The NAT tab of SM with NAT enabled is explained in [Table 109](#).

Table 109 NAT attributes - SM with NAT enabled

NAT Enable	
NAT Enable/Disable :	<input checked="" type="radio"/> Enabled <input type="radio"/> Disabled
<input type="button" value="Save Changes"/>	
WAN Interface	
Connection Type :	DHCP
IP Address :	0.0.0.0
Subnet Mask :	255.255.255.0
Gateway IP Address :	0.0.0.0
Reply to Ping on WAN Interface :	<input type="radio"/> Enabled <input checked="" type="radio"/> Disabled
LAN Interface	
IP Address :	169.254.1.1
Subnet Mask :	255.255.255.0
DMZ Enable :	<input type="radio"/> Enabled <input checked="" type="radio"/> Disabled
DMZ IP Address :	169.254.1.52
LAN DHCP Server	
DHCP Server Enable/Disable :	<input checked="" type="radio"/> Enabled <input type="radio"/> Disabled
DHCP Server Lease Timeout :	30 Days (Range : 1 — 30)
DHCP Start IP :	169.254.1.2
Number of IP's to Lease :	50
DNS Server Proxy :	<input type="radio"/> Enabled <input checked="" type="radio"/> Disabled
DNS IP Address :	<input checked="" type="radio"/> Obtain Automatically (From WAN DHCP or PPPoE) <input type="radio"/> Set Manually
Preferred DNS IP Address :	0.0.0.0
Alternate DNS IP Address :	0.0.0.0
Remote Configuration Interface	
Remote Management Interface :	Enable (Standalone Config)
Connection Type :	<input type="radio"/> DHCP <input checked="" type="radio"/> Static IP
IP Address :	169.254.1.2
Subnet Mask :	255.255.0.0
Gateway IP Address :	169.254.0.0
DHCP DNS IP Address :	<input checked="" type="radio"/> Obtain Automatically <input type="radio"/> Set Manually
Preferred DNS Server :	0.0.0.0
Alternate DNS Server :	0.0.0.0
Domain Name :	example.com
NAT Protocol Parameters	
ARP Cache Timeout :	20 Minutes (Range : 1 — 30)
TCP Session Garbage Timeout :	120 Minutes (Range : 4 — 1440)
UDP Session Garbage Timeout :	4 Minutes (Range : 1 — 1440)

Attribute	Meaning
NAT Enable/Disable	<p>This parameter enables or disabled the Network Address Translation (NAT) feature for the SM. NAT isolates devices connected to the Ethernet or wired side of a SM from being seen directly from the wireless side of the SM. With NAT enabled, the SM has an IP address for transport traffic separate from its address for management, terminates transport traffic, and allows you to assign a range of IP addresses to devices that are connected to the Ethernet or wired side of the SM.</p> <p>When NAT is enabled, VLANs are not supported on the wired side of that SM. You can enable NAT in SMs within a sector where VLAN is enabled in the AP, but this may constrain network design.</p>
WAN Interface	The WAN interface is the RF-side address for transport traffic.
Connection Type	<p>This parameter may be set to</p> <p>Static IP—when this is the selection, all three parameters (IP Address, Subnet Mask, and Gateway IP Address) must be properly populated.</p> <p>DHCP—when this is the selection, the information from the DHCP server configures the interface.</p> <p>PPPoE—when this is the selection, the information from the PPPoE server configures the interface.</p>
Subnet Mask	If Static IP is set as the Connection Type of the WAN interface, then this parameter configures the subnet mask of the SM for RF transport traffic.
Gateway IP Address	If Static IP is set as the Connection Type of the WAN interface, then this parameter configures the gateway IP address for the SM for RF transport traffic.
Reply to Ping on WAN Interface	By default, the radio interface <i>does not</i> respond to pings. If you use a management system (such as WM) that will occasionally ping the SM, set this parameter to Enabled .
LAN Interface	The LAN interface is both the management access through the Ethernet port and the Ethernet-side address for transport traffic. When NAT is enabled, this interface is redundantly shown as the NAT Network Interface Configuration on the IP tab of the Configuration web page in the SM.
IP Address	Assign an IP address for SM/BHS management through Ethernet access to the SM. This address becomes the base for the range of DHCP-assigned addresses.
Subnet Mask	Assign a subnet mask of 255.255.255.0 or a more restrictive subnet mask. Set only the last byte of this subnet mask. Each of the first three bytes is permanently set to 255.
DMZ Enable	Either enable or disable DMZ for this SM/BHS.

DMZ IP Address	If you enable DMZ in the parameter above, set the last byte of the DMZ host IP address to use for this SM when DMZ is enabled. Only one such address is allowed. The first three bytes are identical to those of the NAT private IP address. Ensure that the device that receives network traffic behind this SM is assigned this address. The system provides a warning if you enter an address within the range that DHCP can assign.
DHCP Server	This is the server (in the SM) that provides an IP address to the device connected to the Ethernet port of the SM.
DHCP Server Enable/Disable	Select either Enabled or Disabled . Enable to: <ul style="list-style-type: none"> Allow this SM to assign IP addresses, subnet masks, and gateway IP addresses to attached devices. Assign a start address for DHCP. Designate how many IP addresses may be temporarily used (leased). Disable to: <ul style="list-style-type: none"> Restrict SM/BHS from assigning addresses to attached devices.
DHCP Server Lease Timeout	Based on network performance, enter the number of days between when the DHCP server assigns an IP address and when that address expires. The range of values for this parameter is 1 to 30 days. The default value is 30 days.
DHCP Start IP	If you enable DHCP Server below, set the last byte of the starting IP address that the DHCP server assigns. The first three bytes are identical to those of the NAT private IP address.
Number of IPs to Lease	Enter how many IP addresses the DHCP server is allowed to assign. The default value is 50 addresses.
DNS Server Proxy	This parameter enables or disables advertisement of the SM/BHS as the DNS server. On initial boot up of a SM with the NAT WAN interface configured as DHCP or PPPoE, the SM module will not have DNS information immediately. With DNS Server Proxy disabled, the clients will renew their lease about every minute until the SM has the DNS information to give out. At this point the SM will go to the full configured lease time period which is 30 days by default. With DNS Server Proxy enabled, the SM will give out full term leases with its NAT LAN IP as the DNS server.
DNS IP Address	Select either: Obtain Automatically to allow the system to set the IP address of the DNS server <i>or</i> Set Manually to enable yourself to set both a preferred and an alternate DNS IP address.
Preferred DNS IP Address	Enter the preferred DNS IP address to use when the DNS IP Address parameter is set to Set Manually .

Alternate DNS IP Address	Enter the DNS IP address to use when the DNS IP Address parameter is set to Set Manually and no response is received from the preferred DNS IP address.
Remote Management Interface	<p>To offer greater flexibility in IP address management, the NAT-enabled SM's configured WAN Interface IP address may now be used as the device Remote Management Interface (unless the SM's PPPoE client is set to Enabled)</p> <p>Disable: When this interface is set to "Disable", the SM is not directly accessible by IP address. Management access is only possible through either the LAN (Ethernet) interface or a link from an AP web page into the WAN (RF-side) interface.</p> <p>Enable (Standalone Config): When this interface is set to "Enable (Standalone Config)", to manage the SM/BHS the device must be accessed by the IP addressing information provided in the Remote Configuration Interface section.</p> <hr/> <p> Note When configuring PPPoE over the link, use this configuration option (PPPoE traffic is routed via the IP addressing specified in section Remote Configuration Interface).</p> <hr/> <p>Enable (Use WAN Interface): When this interface is set to "Enable (Use WAN Interface)", the Remote Configuration Interface information is greyed out, and the SM is managed via the IP addressing specified in section WAN Interface).</p> <hr/> <p> Note When using this configuration, the ports defined in section Configuration, Port Configuration are consumed by the device. For example, if FTP Port is configured as 21 by the SM, an FTP server situated below the SM must use a port other than 21. This also applies to DMZ devices; any ports specified in section Configuration, Port Configuration will not be translated through the NAT, they are consumed by the device's network stack for management.</p> <hr/>
Connection Type	<p>This parameter can be set to:</p> <p>Static IP—when this is the selection, all three parameters (IP Address, Subnet Mask, and Gateway IP Address) must be properly populated.</p> <p>DHCP—when this is the selection, the information from the DHCP server configures the interface.</p> <hr/>
IP Address	If Static IP is set as the Connection Type of the WAN interface, then this parameter configures the IP address of the SM for RF management traffic.
Subnet Mask	If Static IP is set as the Connection Type of the WAN interface, then this parameter configures the subnet mask of the SM for RF management traffic.

Gateway IP Address	<p>If Static IP is set as the Connection Type of the WAN interface, then this parameter configures the gateway IP address for the SM for RF management traffic.</p> <p>Note or print the IP settings from this page. Ensure that you can readily associate these IP settings both with the module and with the other data that you store about the module.</p>
DHCP DNS IP Address	<p>Select either:</p> <p>Obtain Automatically to allow the system to set the IP address of the DNS server.</p> <p><i>or</i></p> <p>Set Manually to enable yourself to set both a preferred and an alternate DNS IP address.</p>
Preferred DNS Server	Enter the preferred DNS IP address to use when the DNS IP Address parameter is set to Set Manually .
Alternate DNS Server	Enter the DNS IP address to use when the DNS IP Address parameter is set to Set Manually and no response is received from the preferred DNS IP address.
Domain Name	Domain Name to use for management DNS configuration. This domain name may be concatenated to DNS names used configured for the remote configuration interface.
ARP Cache Timeout	If a router upstream has an ARP cache of longer duration (as some use 30 minutes), enter a value of longer duration than the router ARP cache. The default value of this field is 20 (minutes).
TCP Session Garbage Timeout	Where a large network exists behind the SM, you can set this parameter to lower than the default value of 120 (minutes). This action makes additional resources available for greater traffic than the default value accommodates.
UDP Session Garbage Timeout	You may adjust this parameter in the range of 1 to 1440 minutes, based on network performance. The default value of this parameter is 4 (minutes).

NAT DNS Considerations - SM

SM DNS behavior is different depending on the accessibility of the SM. When NAT is enabled the DNS configuration that is discussed in this document is tied to the RF Remote Configuration Interface, which must be enabled to utilize DNS Client functionality. Note that the WAN DNS settings when NAT is enabled are unchanged with the addition of the management DNS feature discussed in this document.

Table 110 SM DNS Options with NAT Enabled

NAT Configuration	Management Interface Accessibility	DHCP Status	DNS Status
NAT Enabled	RF Remote Management Interface Disabled	N/A	DNS Disabled
	RF Remote Management Interface Enabled	DHCP Disabled	DNS Static Configuration
		DHCP Enabled	DNS from DHCP or DNS Static Configuration

NAT Port Mapping tab - SM

The NAT Port Mapping tab of the SM is explained in [Table 111](#).

Table 111 NAT Port Mapping attributes - SM

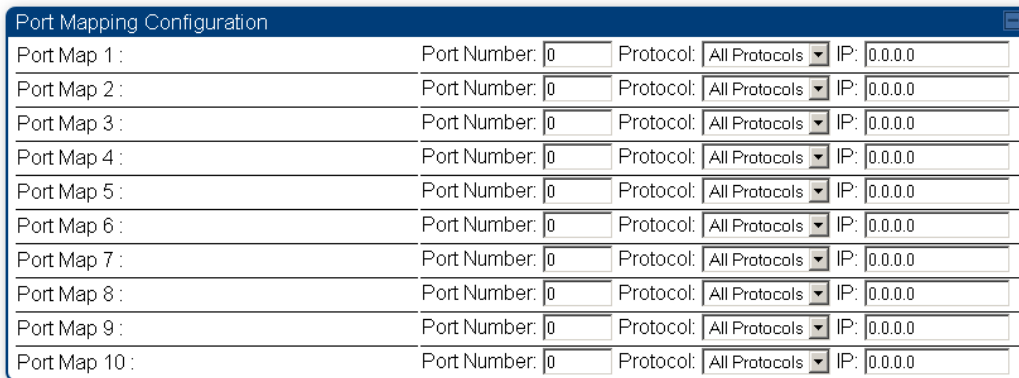

Attribute	Meaning
Port Map 1 to 10	Separate parameters allow you to distinguish NAT ports from each other by assigning a unique combination of port number, protocol for traffic through the port, and IP address for access to the port

DHCP – BHS

Applicable products**PTP:** BHM

DHCP enables a device to be assigned a new IP address and TCP/IP parameters, including a default gateway, whenever the device reboots. Thus DHCP reduces configuration time, conserves IP addresses, and allows modules to be moved to a different network within the Cambium system.

In conjunction with the NAT features, each BHS provides:

- A DHCP server that assigns IP addresses to computers connected to the BHS by Ethernet protocol.
- A DHCP client that receives an IP address for the BHS from a network DHCP server.

Reconnecting to the management PC

If the IP Address, Subnet Mask and Gateway IP Address of the unit have been updated to meet network requirements, then reconfigure the local management PC to use an IP address that is valid for the network. See [Configuring the management PC](#) on page 7-3.

Once the unit reboots, log in using the new IP address. See [Logging into the web interface](#) on page 7-5.

VLAN configuration for PMP

Applicable products**PMP :** AP SM

VLAN Remarking

VLAN Remarking feature allows the user to change the VLAN ID and priority of both upstream and downstream packets at the Ethernet Interface. The remarking configuration is available for:

1. VLAN ID re-marking
2. 802.1p priority re-marking

**Note**

For Q-in-Q VLAN tagged frame, re-marking is performed on the outer tag.

VLAN ID Remarking

SM supports the ability to re-mark the VLAN ID on both upstream and downstream VLAN frames at the Ethernet interface. For instance, a configuration can be added to re-mark VLAN ID 'x' to VLAN ID 'y' as shown in [Table 112](#). AP does not support VLAN ID remarking.

Table 112 VLAN Remarking Example

VLAN frame direction	Remarking
Upstream	SM receives VLAN ID 'x' frame at the Ethernet interface, checks the configuration and re-marks to VLAN ID 'y'. So VLAN ID 'y' frame comes out of AP's Ethernet interface. When SM re-marks, a dynamic entry in VLAN membership table for 'y' is added to allow reception of VLAN ID 'y' downstream packet.
Downstream	AP receives VLAN ID 'y' frame at the Ethernet interface and sends to SM. SM accepts the frame as it has an entry in the membership table and re-marks to VLAN ID 'x'. This reverse re-marking is necessary because the downstream devices do not know of re-marking and are expecting VLAN 'x' frames. This remarking is done just before sending the packet out on Ethernet interface.

802.1P Remarking

AP/BHM and SM/BHS allow re-marking of 802.1p priority bits for the frames received at the Ethernet interface. Priority bits are not re-marked for the packets sent out of Ethernet interface (reverse direction).

Configuration must be added at SM/BHS for upstream frames and at AP/BHM for downstream frames.

VLAN Priority Bits configuration

VLAN Priority Bits Configuration feature allows the user to configure the three 802.1p bits upon assigning VLAN to an ingress packet. The priority bits configuration is available for:

- Default Port VID
- Provider VID
- MAC Address mapped Port VID
- Management VID

Default Port VID

This VID is used for untagged frames and will correspond to the Q-Tag for 802.1Q frames (if VLAN Port Type is Q), or the C-Tag for 802.1ad frames (if the VLAN Port Type is QinQ).

The priority bits used in the Q-tag/C-tag are configurable.

The configuration can be:

- **Promote IPv4/IPv6 priority** – The priority in the IP header is copied to the Q-tag/C-tag.

- **Define priority** – Specify the priority in the range of 0 to 7. This value is used as priority in the Q-tag/C-tag.

MAC Address Mapped VID

If a packet arrives at the SM/BHS that is sourced from a device whose MAC address is in the table, then the corresponding VID is used for that frame's Q-tag (Q port) or C-tag (QinQ port). The priority bits used in the Q-tag/C-tag are configurable similar to default port VID.

Provider VID

The provider VID is used for the S-tag. The priority bits used in the S-tag are configurable similar to default port VID. Provider VID has an extra priority configuration:

- **Copy inner tag 802.1p priority** – The priority in the C-tag is copied to the S-tag.

Management VID

This VID is used to communicate with AP/BHM and SM/BHS for management purposes. The priority bits used in the Q-tag are configurable similar to default port VID.

Use AP's Management VID for ICC connected SM

This feature allows the SM to use the AP's management VLAN ID when the SM is registered to the AP via ICC. This feature is useful for the customer who uses a different management VID for the SM and AP and Zero Touch feature is enabled for configuration. This parameter may be accessed via the **Configuration > VLAN** page on the AP's web management interface.

VLAN page of AP

The **VLAN** tab of the AP/BHM is explained in [Table 113](#).

Table 113 AP/BHM VLAN tab attributes

VLAN Configuration

VLAN :	<input type="radio"/> Enabled <input checked="" type="radio"/> Disabled
Always use Local VLAN Config :	<input type="radio"/> Enabled <input checked="" type="radio"/> Disabled <small>(NOTE: If you want to run spectrum analysis on this AP, enable this option to keep VLAN settings intact when booting as an SM.)</small>
Allow Frame Types :	All Frames ▾
Dynamic Learning :	<input checked="" type="radio"/> Enabled <input type="radio"/> Disabled
VLAN Aging Timeout :	25 Minutes (Range : 5 — 1440 Minutes)
Management VID (Range : 1 — 4094) :	1
QinQ EtherType :	0x88a8 ▾
Use AP's Management VID for ICC connected SM :	<input type="radio"/> Enabled <input checked="" type="radio"/> Disabled

Active Configuration

VLAN Not Active

VLAN Membership Configuration

VLAN Membership Table Configuration : 1 (Range : 1 — 4094)

VLAN Membership Table

Empty Set

VLAN 802.1p Remarking

Source VLAN :	1 (Range : 1 — 4094)
Remark Priority :	0 (Range : 0 — 7)

VLAN Remarking Table

Empty Set

Attribute	Meaning
VLAN	Specify whether VLAN functionality for the AP and all linked SMs must (Enabled) or may not (Disabled) be allowed. The default value is Disabled .
Always use Local VLAN Config	Enable this option before you reboot this AP as a SM to use it to perform spectrum analysis. Once the spectrum analysis completes, disable this option before you reboot the module as an AP,
Allow Frame Types	Select the type of arriving frames that the AP must tag, using the VID that is stored in the Untagged Ingress VID parameter. The default value is All Frames .
Dynamic Learning	Specify whether the AP must (Enabled) or not (Disabled) add the VLAN IDs (VIDs) of upstream frames to the VID table. (The AP passes frames with VIDs that are stored in the table both upstream and downstream.). The default value is Enabled .

VLAN Aging Timeout Specify how long the AP must keep dynamically learned VIDs. The range of values is 5 to 1440 (minutes). The default value is 25 (minutes).



Note

VIDs that you enter for the Management VID and VLAN Membership parameters do not time out.

Management VID Enter the VID that the operator wishes to use to communicate with the module manager. The range of values is 1 to 4095. The default value is 1.

QinQ EtherType Modules can be configured with 802.1ad Q-in-Q DVLAN (Double-VLAN) tagging which is a way for an operator to put an 802.1Q VLAN inside of an 802.1ad VLAN. A nested VLAN, which is the original 802.1Q tag and a new second 802.1ad tag, allows for bridging of VLAN traffic across a network and segregates the broadcast domains of 802.1Q VLANs. Q-in-Q can be used with PPPoE and/or NAT.

The 802.1ad standard defines the S-VLAN as the Service Provider VLAN and the C-VLAN as the customer VLAN. The radio software does 2 layer Q-in-Q whereby the C-VLAN is the 802.1Q tag and the S-VLAN is the second layer Q tag as shown below:

Table 114 Q-in-Q Ethernet frame

Ethernet Header	S-VLAN EthType	C-VLAN EthType	IP Data EthType
	0x88a8	0x8100	0x0800

The 802.1ad S-VLAN is the outer VLAN that is configurable on the **Configuration > VLAN** web page of the AP. The Q-in-Q EtherType parameter is configured with a default EtherType of 0x88a8 in addition to four alternate EtherTypes that can be configured to aid in interoperability with existing networks that use a different EtherType than the default.

The C-VLAN is the inner VLAN tag, which is the same as 802.1Q. As a top level concept, this operates on the outermost tag at any given time, either “pushing” a tag on or “popping” a tag off. This means packets will at most transition from an 802.1Q frame to an 801.ad frame (with a tag “pushed” on) or an untagged 802.1 frame (with the tag “popped” off. Similarly, for an 802.1ad frame, this can only transition from an 802.1ad frame to an 802.1Q frame (with the tag “popped” off) since the radio software only supports 2 levels of tags

Use AP's Management VID for ICC connected SM This field allows the SM to use the AP's management VLAN ID when the SM is registered to the AP via ICC.

VLAN Not Active When VLAN is enabled in the AP, the Active Configuration block provides the following details as read-only information in this tab. In the Cambium fixed wireless broadband IP network, each device of any type is automatically a permanent member of VID 1. This facilitates deployment of devices that have VLAN enabled with those that do not.

VLAN Membership Table Configuration	For each VLAN in which you want the AP to be a member, enter the VLAN ID and then click the Add Member button. Similarly, for any VLAN in which you want the AP to no longer be a member, enter the VLAN ID and then click the Remove Member button.
VLAN Membership table	This field lists the VLANs that an AP is a member of. As the user adds a number between 1 and 4094, this number is populated here.
Source VLAN (Range: 1-4094)	Enter the VID for which the operator wishes to remark the 802.1p priority for the downstream packets. The range of values is 1 to 4094. The default value is 1.
Remark Priority (Range 0-7)	This is the priority you can assign to the VLAN Tagged packet. Priority of 0 is the highest.
VLAN Remarking table	As the user enters a VLAN and a Remarking priority, this information is added in this table.

VLAN page of SM

The VLAN tab of SM/BHS is explained in [Table 115](#).

Table 115 SM VLAN attributes

VLAN Configuration		
VLAN Port Type :	Q	
Accept QinQ Frames :	<input type="radio"/> Enabled <input checked="" type="radio"/> Disabled	
Allow Frame Types :	All Frames	
Dynamic Learning :	<input checked="" type="radio"/> Enabled <input type="radio"/> Disabled	
VLAN Aging Timeout :	25 Minutes (Range : 5 — 1440 Minutes)	
Management VID :	1 (Range : 1 — 4094)	
SM Management VID Pass-through :	<input type="radio"/> Disable <input checked="" type="radio"/> Enable (NOTE: If disabled, MVID traffic will not be allowed to or from the SM wired interface. Also, if Management VID is the same as a Port VID (Default or MAC-based), then this setting will be ignored and assumed to be Enabled.)	
Default Port VID :	1 (Range : 1 — 4094)	
Port VID MAC Address Mapping MAC address of 0's indicates an unused entry. :	00-00-00-00-00-00 VID 1 (Range : 1 — 4094)	
	00-00-00-00-00-00 VID 1 (Range : 1 — 4094)	
	00-00-00-00-00-00 VID 1 (Range : 1 — 4094)	
	00-00-00-00-00-00 VID 1 (Range : 1 — 4094)	
	00-00-00-00-00-00 VID 1 (Range : 1 — 4094)	
	00-00-00-00-00-00 VID 1 (Range : 1 — 4094)	
	00-00-00-00-00-00 VID 1 (Range : 1 — 4094)	
	00-00-00-00-00-00 VID 1 (Range : 1 — 4094)	
	00-00-00-00-00-00 VID 1 (Range : 1 — 4094)	
Provider VID :	1 (Range : 1 — 4094)	
Active Configuration		
Default Port VID : 1		
MAC Address VID Map:		
Management VID : 1		
SM Management VID Passthrough : Enabled		
Dynamic Ageing Timeout : 25		
Allow Learning : Yes		
Allow Frame Type : All Frame Types		
QinQ : Disabled		
QinQ EthType : 0x88a8		
Allow QinQ Tagged Frames : No		
Current VID Member Set:		
VID Number	Type	Age
1	Permanent	0

Attribute	Meaning
VLAN Port Type	By default this is Q, indicating that it is to operate in the existing manner. The other option is Q-in-Q, which indicates that it must be adding and removing the S-Tag, and adding a C-Tag if necessary for untagged packets. The VLAN Port type corresponds to the Ethernet port of the SM/BHS. Currently, the internal management interfaces will always operate as Q ports.

Accept QinQ Frames	This option is valid for the Q-in-Q port so that the user may force blocking of existing 802.1ad Q-in-Q frames. This way, only untagged or single tagged packets will come in and out of the Ethernet interface. If a Q-in-Q frame is about ingress or egress the Ethernet interface and this is disabled, it is dropped and a filter entry will show up on the VLAN Statistics page as DVLAN Egress or DVLAN Ingress.
Allow Frame Types	Select the type of arriving frames that the SM must tag, using the VID that is stored in the Untagged Ingress VID parameter. The default value is All Frames . Tagged Frames Only: The SM only tags incoming VLAN-tagged frames Untagged Frames Only: The SM will only tag incoming untagged frames
Dynamic Learning	Specify whether the SM must (Enable) or not (Disable) add the VIDs of upstream frames (that enter the SM through the wired Ethernet interface) to the VID table. The default value is Enable .
VLAN Aging Timeout	Specify how long the SM/BHS must keep dynamically learned VIDs. The range of values is 5 to 1440 (minutes). The default value is 25 (minutes).
	<div style="display: flex; align-items: center;">  <div> <p>Note</p> <p>VIDs that you enter for the Untagged Ingress VID and Management VID parameters do not time out.</p> </div> </div>
Management VID	Enter the VID that the SM/BHS must share with the AP/BHM. The range of values is 1 to 4095. The default value is 1 .
SM Management VID Pass-through	Specify whether to allow the SM/BHS (Enabled) or the AP/RADIUS (Disabled) to control the VLAN settings of this SM. The default value is Enabled . When VLAN is enabled in the AP to whom this SM is registered, the Active Configuration block provides the following details as read-only information in this tab. In the Cambium fixed wireless broadband IP network, each device of any type is automatically a permanent member of VID 1. This facilitates deployment of devices that have VLAN enabled with those that do not. If disabled, MVID traffic is not allowed to or from the SM wired interface. Also, if Management VID is the same as a Port VID (Default or MAC-based), then this setting is ignored and assumed to be Enabled.
Default Port VID	This is the VID that is used for untagged frames and will correspond to the Q-Tag for 802.1Q frames (if VLAN Port Type is Q), or the C-Tag for 802.1ad frames (if the VLAN Port Type is Q-in- Q).

Port VID MAC Address Mapping	These parameters allow operators to place specific devices onto different VLANs (802.1Q tag or 802.1ad C-tag) based on the source MAC address of the packet. If the MAC address entry is 00-00-00-00-00-00 then that entry is not used. If a packet arrives at the SM that is sourced from a device whose MAC address is in the table, then the corresponding VID is used for that frame's Q-tag (Q port) or C-tag (Q-in-Q port). If there is no match, then the Default Port VID is used. This table is also used in the downstream direction for removal of the tag based on the destination MAC address so that an untagged (for Q port) or Q-Tagged (for Q-in-Q port) frame is delivered to the end device. You may use wildcards for the non-OUI (Organizationally Unique Identifier) portion of the MAC address, which is the last 3 bytes. MAC addresses contain 6 bytes, the first 3 of which are the OUI of the vendor that manufactured the device and the last 3 are unique to that vendor OUI. If you want to cover all devices from a known vendor's OUI, you have to specify 0xFF for the remaining 3 bytes. So, for example, if you wanted all devices from a specific vendor with an OUI of 00-95-5b (which is a Netgear OUI) to be on the same VID of 800, you have to specify an entry with MAC address 00-95-5b-ff-ff-ff. Then, any device underneath of the SM with MAC addresses starting with 00-95-5b is put on VLAN 800.
Provider VID	The provider VID is used for the S-tag. It is only used if the Port Type is Q-in-Q and will always be used for the S-tag. If an existing 802.1Q frame arrives, the Provider VID is what is used for adding and removing of the outer S-tag. If an untagged frame arrives to a Q-in-Q port, then the Provider VID is the S-tag and the Default Port VID (or Port VID MAC Address Mapping , if valid) is used for the C-tag.
Active Configuration, Default Port VID	This is the value of the parameter of the same name, configured above.
Active Configuration, MAC Address VID Map	This is the listing of the MAC address VIDs configured in Port VID MAC Address Mapping .
Active Configuration, Management VID	This is the value of the parameter of the same name, configured above.
Active Configuration, SM Management VID Pass-Through	This is the value of the parameter of the same name, configured above.
Active Configuration, Dynamic Aging Timeout	This is the value of the VLAN Aging Timeout parameter configured above.
Active Configuration, Allow Learning	Yes is displayed if the value of the Dynamic Learning parameter above is Enabled . No is displayed if the value of Dynamic Learning is Disabled .
Active Configuration, Allow Frame Type	This displays the selection that was made from the drop-down list at the Allow Frame Types parameter above.

Active Configuration, QinQ	This is set to Enabled if VLAN Port Type is set to QinQ , and is set to Disabled if VLAN Port Type is set to Q .
Active Configuration, QinQ EthType	This is the value of the QinQ EtherType configured in the AP.
Active Configuration, Allow QinQ Tagged Frames	This is the value of Accept QinQ Frames , configured above.
Active Configuration, Current VID Member Set, VID Number	This column lists the ID numbers of the VLANs in which this module is a member, whether through assignment or through dynamic learning.
Active Configuration, Current VID Member Set, Type	For each VID number in the first column, the entry in this column correlates the way in which the module became and continues to be a member: Permanent —This indicates that the module was assigned the VID number through direct configuration by the operator. Dynamic —This indicates that the module adopted the VID number through enabled dynamic learning, when a tagged packet from a SM behind it in the network or from a customer equipment that is behind the SM in this case, was read.
Active Configuration, Current VID Member Set, Age	For each VID number in the first column of the table, the entry in this column reflects whether or when the VID number will time out: Permanent type - Number never times out and this is indicated by the digit 0. Dynamic type - Age reflects what is configured in the VLAN Aging Timeout parameter in the Configuration => VLAN tab of the AP or reflects a fewer number of minutes that represents the difference between what was configured and what has elapsed since the VID was learned. Each minute, the Age decreases by one until, at zero, the AP deletes the learned VID, but can it again from packets sent by elements that are beneath it in the network.

**Note**

Values in this Active Configuration block can differ from attempted values in configurations:

The AP can override the value that the SM has configured for SM Management VID Pass-Through.

VLAN Membership tab of SM

The **Configuration > VLAN > VLAN Membership** tab is explained in [Table 116](#).

Table 116 SM VLAN Membership attributes

The screenshot shows two panels. The top panel, titled "VLAN Membership Configuration", contains a text input field for "VLAN Membership Table Configuration" with the value "10" and a range "(Range : 1 — 4094)". Below the input are two buttons: "Add Member" and "Remove Member". The bottom panel, titled "VLAN Membership Table", displays a table with columns "VLAN Membership Table VID Number", "Type", and "Age". The table contains one row with the value "10" under "VLAN Membership Table VID Number" and "Static" under "Type".

Attribute	Meaning
VLAN Membership Table Configuration	For each VLAN in which you want the AP to be a member, enter the VLAN ID and then click the Add Member button. Similarly, for any VLAN in which you want the AP to no longer be a member, enter the VLAN ID and then click the Remove Member button.

VLAN configuration for PTP

Applicable products

PTP: BHM BMS

VLAN page of BHM

The VLAN tab of BHS is explained in [Table 117](#).

Table 117 BHM VLAN page attributes

The screenshot shows two panels. The top panel, titled "VLAN Configuration", contains several fields: "VLAN:" with radio buttons for "Enabled" (selected) and "Disabled"; "VLAN Port Type:" with a dropdown menu set to "Q"; "Accept QinQ Frames:" with radio buttons for "Enabled" and "Disabled" (selected); "Management VID (Range : 1 — 4094):" with a value of "1", "Priority" of "0", and a dropdown for "Promote IPv4/IPv6 priority"; "Default Port VID (Range : 1 — 4094):" with a value of "1", "Priority" of "0", and a dropdown for "Promote IPv4/IPv6 priority"; and "QinQ EtherType:" with a dropdown set to "0x88a8". The bottom panel, titled "Active Configuration", displays summary information: "Default Port VID : 1 Priority : Promote IPv4/IPv6 priority", "Management VID : 1 Priority : Promote IPv4/IPv6 priority", "QinQ : Disabled", "QinQ EthType : 0x88a8", "Allow QinQ Tagged Frames : No", and "Current VID Member Set:" followed by a table:

VID Number	Type	Age
1	Permanent	0

Attribute	Meaning				
VLAN	Specify whether VLAN functionality for the BHM and all linked BHS must be (Enabled) or may not (Disabled) be allowed. The default value is Disabled .				
VLAN Port Type	By default this is Q, indicating that it is to operate in the existing manner. The other option is Q-in-Q, which indicates that it must be adding and removing the S-Tag, and adding a C-Tag if necessary for untagged packets. The VLAN Port type corresponds to the Ethernet port of the BHS. Currently, the internal management interfaces will always operate as Q ports.				
Accept QinQ Frames	This option is valid for the Q-in-Q port so that the user may force blocking of existing 802.1ad Q-in-Q frames. This way, only untagged or single tagged packets will come in and out of the Ethernet interface. If a Q-in-Q frame is about ingress or egress the Ethernet interface and this is disabled, it is dropped and a filter entry will show up on the VLAN Statistics page as DVLAN Egress or DVLAN Ingress.				
Management VID (Range 1-4094)	Enter the VID that the BHS must share with the BHM. The range of values is 1 to 4095. The default value is 1 .				
Default Port VID (Range 1-4094)	This is the VID that is used for untagged frames and corresponds to the Q-Tag for 802.1Q frames (if VLAN Port Type is Q), or the C-Tag for 802.1ad frames (if the VLAN Port Type is Q-in- Q).				
QinQ Ether Type	<p>Modules can be configured with 802.1ad Q-in-Q DVLAN (Double-VLAN) tagging which is a way for an operator to put an 802.1Q VLAN inside of an 802.1ad VLAN. A nested VLAN, which is the original 802.1Q tag and a new second 802.1ad tag, allows for bridging of VLAN traffic across a network and segregates the broadcast domains of 802.1Q VLANs. Q-in-Q can be used with PPPoE and/or NAT.</p> <p>The 802.1ad standard defines the S-VLAN as the Service Provider VLAN and the C-VLAN as the customer VLAN. The radio software does 2 layer Q-in-Q whereby the C-VLAN is the 802.1Q tag and the S-VLAN is the second layer Q tag as shown below:</p> <table border="1" data-bbox="497 1431 1348 1523"> <tbody> <tr> <td>Ethernet Header</td> <td>S-VLAN EthType 0x88a8</td> <td>C-VLAN EthType 0x8100</td> <td>IP Data EthType 0x0800</td> </tr> </tbody> </table> <p>The 802.1ad S-VLAN is the outer VLAN that is configurable on the Configuration > VLAN web page of the BHM. The Q-in-Q EtherType parameter is configured with a default EtherType of 0x88a8 in addition to four alternate EtherTypes that can be configured to aid in interoperability with existing networks that use a different EtherType than the default.</p>	Ethernet Header	S-VLAN EthType 0x88a8	C-VLAN EthType 0x8100	IP Data EthType 0x0800
Ethernet Header	S-VLAN EthType 0x88a8	C-VLAN EthType 0x8100	IP Data EthType 0x0800		

The C-VLAN is the inner VLAN tag, which is the same as 802.1Q. As a top level concept, this operates on the outermost tag at any given time, either “pushing” a tag on or “popping” a tag off. This means packets will at most transition from an 802.1Q frame to an 801.ad frame (with a tag “pushed” on) or an untagged 802.1 frame (with the tag “popped” off. Similarly, for an 802.1ad frame, this can only transition from an 802.1ad frame to an 802.1Q frame (with the tag “popped” off) since the radio software only supports 2 levels of tags.

VLAN Not Active

When VLAN is enabled in the BHM, the Active Configuration block provides the following details as read-only information in this tab. In the Cambium fixed wireless broadband IP network, each device of any type is automatically a permanent member of VID 1. This facilitates deployment of devices that have VLAN enabled with those that do not.

VLAN page of BHS

The VLAN tab of BHS is explained in [Table 118](#).

Table 118 BHS VLAN page attributes

The screenshot shows the 'VLAN Configuration' tab in a web interface. It contains several fields:

- VLAN :** Radio buttons for 'Enabled' and 'Disabled', with 'Disabled' selected.
- VLAN Port Type :** A dropdown menu showing 'Q'.
- Accept QinQ Frames :** Radio buttons for 'Enabled' and 'Disabled', with 'Disabled' selected.
- Management VID (Range : 1 — 4094) :** A text box containing '1', followed by 'Priority 0' and '(0 — 7) Promote IPv4/IPv6 priority'.
- Default Port VID (Range : 1 — 4094) :** A text box containing '1', followed by 'Priority 0' and '(0 — 7) Promote IPv4/IPv6 priority'.

 Below the configuration fields is an 'Active Configuration' section with a single entry: 'VLAN Not Active'.

Attribute	Meaning
VLAN	Specify whether VLAN functionality for the BHM and all linked BHS must be (Enabled) or may not (Disabled) be allowed. The default value is Disabled.
VLAN Port Type	By default this is Q, indicating that it is to operate in the existing manner. The other option is Q-in-Q, which indicates that it must be adding and removing the S-Tag, and adding a C-Tag if necessary for untagged packets. The VLAN Port type corresponds to the Ethernet port of the BHS. Currently, the internal management interfaces will always operate as Q ports.
Accept QinQ Frames	This option is valid for the Q-in-Q port so that the user may force blocking of existing 802.1ad Q-in-Q frames. This way, only untagged or single tagged packets will come in and out of the Ethernet interface. If a Q-in-Q frame is about ingress or egress the Ethernet interface and this is disabled, it is dropped and a filter entry will show up on the VLAN Statistics page as DVLAN Egress or DVLAN Ingress.
Management VID (Range 1-4094)	Enter the VID that the BHS must share with the BHM. The range of values is 1 to 4095. The default value is 1.
Default Port VID (Range 1-4094)	This is the VID that is used for untagged frames and corresponds to the Q-Tag for 802.1Q frames (if VLAN Port Type is Q), or the C-Tag for 802.1ad frames (if the VLAN Port Type is Q-in-Q).
VLAN Not Active	When VLAN is enabled in the BHM, the Active Configuration block provides the following details as read-only information in this tab. In the Cambium fixed wireless broadband IP network, each device of any type is automatically a permanent member of VID 1. This facilitates deployment of devices that have VLAN enabled with those that do not.

PPPoE page of SM

Applicable products	PMP :	<input checked="" type="checkbox"/> SM
----------------------------	--------------	--

Point-to-Point Protocol over Ethernet (PPPoE) is a protocol that encapsulates PPP frames inside Ethernet frames (at Ethernet speeds). Benefits to the network operator may include

- Access control
- Service monitoring
- Generation of statistics about activities of the customer
- Re-use of infrastructure and operational practices by operators who already use PPP for other networks

PPPoE options are configurable for the SM only, and the AP indicates whether or not PPPoE is enabled for a specific subscriber.

When PPPoE is enabled, once the RF session comes up between the SM and the AP, the SM will immediately attempt to connect to the PPPoE Server. You can monitor the status of this by viewing the PPPoE Session Log in the Logs section (Administrator only). Every time the RF session comes up, the SM will check the status of the link and if it is down, the SM will attempt to redial the link if necessary depending on the Timer Type. Also, on the Configuration page, the user may 'Connect' or 'Disconnect' the session manually. This can be used to override the session to force a manual disconnect and/or reconnect if there is a problem with the session.

In order to enable PPPoE, NAT MUST be enabled on the SM and Translation Bridging MUST be disabled on the AP. These items are strictly enforced for you when you are trying to enable PPPoE. A message will indicate any prerequisites not being met. Also, the NAT Public IP DHCP client cannot be enabled, because the NAT Public IP is received through the IPCP process of the PPPoE discovery stages.

The pre-requisites are:

- NAT MUST be enabled on the SM
 - NAT DHCP Client is disabled automatically. The NAT public IP is received from the PPPoE Server.
 - NAT Public Network Interface Configuration will not be used and must be left to defaults. Also NAT Public IP DHCP is disabled if it is enabled.
- Translation Bridging MUST be DISABLED on the AP
 - This will only be determined if the SM is in session since the SM won't know the AP configuration otherwise. If the SM is not in session, PPPoE can be enabled but if the SM goes into session to a Translation Bridge-enabled AP, then PPPoE will not be enabled.

The PPPoE configuration parameters are explained in [Table 119](#).

Table 119 SM PPPoE attributes

The screenshot shows a 'PPPoE Configuration' window with the following settings:

- PPPoE: Enabled, Disabled
- NAT DHCP Client will be disabled. (Red text)
- Access Concentrator: [Empty text box]
- Service Name: [Empty text box]
- Authentication Type: None (dropdown menu)
- User Name: admin (text box)
- Password: [Masked with dots]
- MTU:
 - Use MTU Received from PPPoE Server
 - Use User Defined MTU
 - 1492 (text box)
- Timer Type: Keep Alive (dropdown menu)
- Timer Period: 30 seconds (20s Minimum) (text box)
- TCP MSS Clamping: Enabled, Disabled

Attribute	Meaning
Access Concentrator	An optional entry to set a specific access concentrator to connect to for the PPPoE session. If this is blank, the SM will accept the first access concentrator which matches the service name (if specified). This is limited to 32 characters.
Service Name	An optional entry to set a specific service name to connect to for the PPPoE session. If this is left blank the SM will accept the first service option that comes back from the access concentrator specified above, if any. This is limited to 32 characters.
Authentication Type	None means that no PPPoE authentication is implemented CHAP/PAP means that CHAP authentication is attempted first, then PAP authentication. The same password is used for both types.
User Name	This is the CHAP/PAP user name that is used if CHAP/PAP authentication is selected. If None is selected for authentication then this field is unused. This is limited to 32 characters.
Password	This is the CHAP/PAP password that is used if PAP authentication is selected. If None is selected for authentication then this field is unused. This is limited to 32 characters.
MTU	Use MTU Received from PPPoE Server causes the SM to use the MRU of the PPPoE server received in LCP as the MTU for the PPPoE link.

	<p>Use User Defined MTU allows the operator to specify an MTU value to use to override any MTU that may be determined in the LCP phase of PPPoE session setup. If this is selected, the user is able to enter an MTU value up to 1492. However, if the MTU determined in LCP negotiations is less than this user-specified value, the SM will use the smaller value as its MTU for the PPPoE link.</p>
Timer Type	<p>Keep Alive is the default timer type. This timer will enable a keepalive that will check the status of the link periodically. The user can set a keepalive period. If no data is seen from the PPPoE server for that period, the link is taken down and a reconnection attempt is started. For marginal links, the keep alive timer can be useful so that the session will stay alive over periodic dropouts. The keepalive timer must be set such that the session can outlast any session drop. Some PPPoE servers will have a session check timer of their own so that the timeouts of the server and the SM are in sync, to ensure one side does not drop the session prematurely.</p> <p>Idle Timeout enables an idle timer that checks the usage of the link from the customer side. If there is no data seen from the customer for the idle timeout period, the PPPoE session is dropped. Once data starts flowing from the customer again, the session is started up again. This timer is useful for users who may not be using the connection frequently. If the session is idle for long periods of time, this timer will allow the resources used by the session to be returned to the server. Once the connection is used again by the customer, the link is reestablished automatically.</p>
Timer Period	The length in seconds of the PPPoE keepalive timer.
TCP MSS Clamping	<p>If this is enabled, then the SM will alter TCP SYN and SYN-ACK packets by changing the Maximum Segment Size to be compatible with the current MTU of the PPPoE link. This way, the user does not have to worry about MTU on the client side for TCP packets. The MSS is set to the current MTU – 40 (20 bytes for IP headers and 20 bytes for TCP headers). This will cause the application on the client side to not send any TCP packets larger than the MTU. If the network is exhibiting large packet loss, try enabling this option. This may not be an option on the PPPoE server itself. The SM will NOT reassemble IP fragments, so if the MTUs are incorrect on the end stations, then MSS clamping will solve the problem for TCP connections.</p>

IP4 and IPv6

Applicable products PMP : AP SM PTP: BHM BMS

IPv4 and IPv6 Prioritization

450 Platform Family provides operators the ability to prioritize IPv6 traffic in addition to IPv4 traffic. IPv6/IPv4 prioritization can be configured by selecting a CodePoint and the corresponding priority from the GUI of the AP/BHM and the IPv6/IPv4 packet is set up accordingly. There is no GUI option for selecting IPv6 or IPv4 priority. Once the priority is set, it is set for IPv4 and IPv6 packets.

Configuring IPv4 and IPv6 Priority

IPv4 and IPv6 prioritization is set using the DiffServ tab on the AP/BHM and SM/BHS (located at **Configuration > DiffServ**). A priority set to a specific CodePoint will apply to both IPv4 and IPv6 traffic.

Table 120 DiffServ attributes – AP/BHM

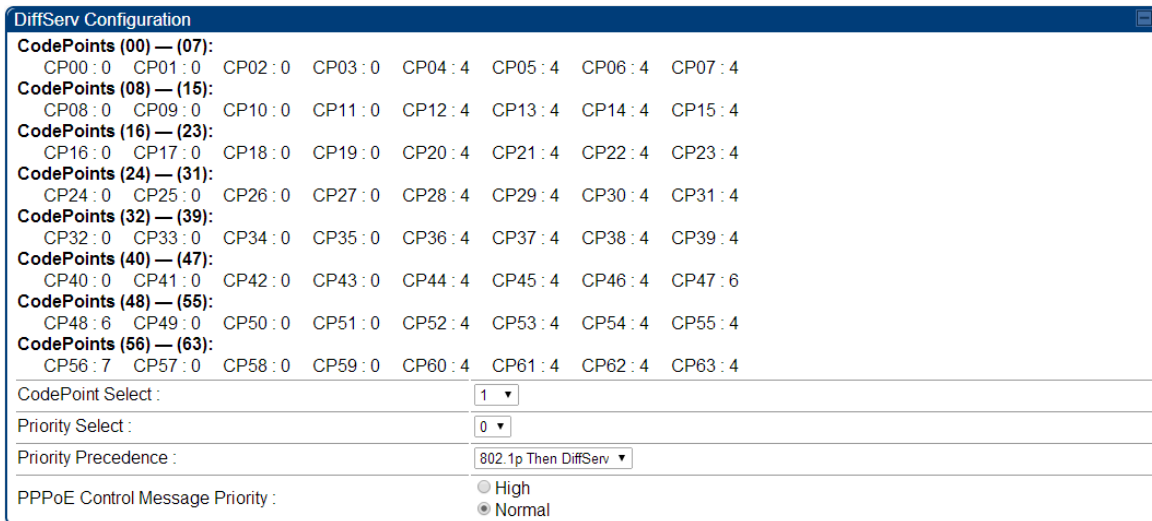

Attribute	Meaning
CodePoint 1 through CodePoint 47	Priorities of 0 through 3 map to the low-priority channel; 4 through 7 to the high- priority channel. The mappings are the same as 802.1p VLAN priorities. Consistent with RFC 2474
CodePoint 49 through CodePoint 55	CodePoint 0 is predefined to a fixed priority value of 0 (low-priority channel). CodePoint 48 is predefined to a fixed priority value of 6 (high-priority channel). CodePoint 56 is predefined to a fixed priority value of 7 (high-priority channel).
CodePoint 57 through CodePoint 63	Operator cannot change any of these three fixed priority values. Among the settable parameters, the priority values (and therefore the handling of packets in the high or low priority channel) are set in the AP/BHM for all downlinks within the sector and in the SM/BHS for each uplink.

CodePoint Select	This represents the CodePoint Selection to be modified via Priority Select
Priority Select	The priority setting input for the CodePoint selected in CodePoint Select
Priority Precedence	Allows operator to decide if 802.1p or DiffServ priority bits must be used first when making priority decisions.
PPPoE Control Message Priority	Operators may configure the AP/BHM to utilize the high priority channel for PPPoE control messages. Configuring the AP/BHM in this fashion can benefit the continuity of PPPoE connections when there are issues with PPPoE sessions being dropped in the network. This prioritization may be configured in the DiffServ tab in the Configuration menu of the AP/BHM.

IPv4 and IPv6 Filtering

The operator can filter (block) specified IPv6 protocols including IPv4 and ports from leaving the AP/BHM and SM/BHS and entering the network. This protects the network from both intended and inadvertent packet loading or probing by network users. By keeping the specified protocols or ports off the network, this feature also provides a level of protection to users from each other.

Configuring IPv4 and IPv6 Filtering

IPv6 filters are set using the Protocol Filtering tab on the AP/BHM and SM/BHS (at **Configuration > Protocol Filtering**). Once a filter is set for a packet type, those packets will not be sent over the RF interface depending on “Filter Direction” setting.

Table 121 Packet Filter Configuration attributes

Packet Filter Configuration

Packet Filter Types :

- PPPoE
- All IPv4
 - SMB (Network Neighborhood)
 - SNMP
 - Bootp Client
 - Bootp Server
 - IPv4 Multicast
 - User Defined Port 1 (See Below)
 - User Defined Port 2 (See Below)
 - User Defined Port 3 (See Below)
 - All other IPv4
- All IPv6
 - SMB (Network Neighborhood)
 - SNMP
 - Bootp Client
 - Bootp Server
 - IPv6 Multicast
 - All other IPv6
- ARP
- All others

Filter Direction :

- Upstream
- Downstream

User Defined Port Filtering Configuration

Port #1 : (Decimal Value)

TCP : Enabled Disabled

UDP : Enabled Disabled

Port #2 : (Decimal Value)

TCP : Enabled Disabled

UDP : Enabled Disabled

Port #3 : (Decimal Value)

TCP : Enabled Disabled

UDP : Enabled Disabled

AP Specialty Filters

RF Telnet Access : Enabled Disabled

PPPoE PADI Downlink Forwarding : Enabled Disabled

Attribute	Meaning
Packet Filter Types	<p>For any box selected, the Protocol and Port Filtering feature blocks the associated protocol type.</p> <p>To filter packets in any of the user-defined ports, you must do all of the following:</p> <ul style="list-style-type: none"> Check the box for User Defined Port <i>n</i> (See Below) in the Packet Filter Types section of this tab. Provide a port number at Port #<i>n</i>. in the User Defined Port Filtering Configuration section of this tab

	<ul style="list-style-type: none">• Enable TCP and/or UDP by clicking the associated radio button
Filter Direction	Operators may choose to filter upstream (uplink) RF packets or downstream (downlink) RF packets.
User Defined Port Filtering Configuration	You can specify ports for which to block subscriber access, regardless of whether NAT is enabled.

Upgrading the software version and using CNUT

This section consists of the following procedures:

- [Checking the installed software version](#) on page 7-64
- [Upgrading to a new software version](#) on page 7-64



Caution

If the link is operational, ensure that the remote end of the link is upgraded first using the wireless connection, and then the local end can be upgraded. Otherwise, the remote end may not be accessible.

Use CNUT 4.10.4 or later version and always refer to the software release notes before upgrading system software. The release notes are available at:

<https://support.cambiumnetworks.com/files/pmp450>

<https://support.cambiumnetworks.com/files/ptp450>

Checking the installed software version

To check the installed software version, follow these instructions:

Procedure 18 Checking the installed software version

- 1 Click on **General** tab under **Home** menu.
- 2 Note the installed Software Version (under Device Information):
PMP/PTP 450/450i/450m

Software Version :	CANOPY 15.0.1 AP-None
--------------------	-----------------------
- 3 Go to the support website (see [Contacting Cambium Networks](#) on page 1) and find Point-to-Multipoint software updates. Check that the latest 450 Platform Family software version is the same as the installed Software Version.
- 4 To upgrade software to the latest version, see [Upgrading to a new software version](#) on page 7-64.

Upgrading to a new software version

All 450 platform modules are upgraded using the Canopy Network Updater Tool. The Canopy Network Updater Tool (CNUT) manages and automates the software upgrade process for a Canopy radio, or CMM4 (but not its 14-port switch) across the network. This eliminates the need for an administrator to visit each radio in the network (or each AP/BHM while using the Autoupdate feature) to upgrade the modules.

**Note**

Please ensure that you have the most up-to-date version of CNUT by browsing to the Customer Support Web Page located:

<http://www.cambiumnetworks.com/support/management-tools/cnut>

This section includes an example of updating a single unit before deployment. System-wide upgrading procedures may be found in the *CNUT Online Help* manual, which can be found on the Cambium support website (see [Contacting Cambium Networks](#) on page 1).

CNUT functions

The Canopy Network Updater tool has the following functions:

- Automatically discovers all network elements
- Executes a UDP command that initiates and terminates the Auto-update mode within APs/BHMs. This command is both secure and convenient:
 - For security, the AP/BHM accepts this command from only the IP address that you specify in the Configuration page of the AP/BHM.
 - For convenience, Network Updater automatically sets this Configuration parameter in the APs/BHMs to the IP address of the Network Updater server when the server performs any of the update commands.
- CNUT supports HTTP and HTTPS
- Allows you to choose the following among updating:
 - Your entire network.
 - Only elements that you select.
 - Only network branches that you select.
- Provides a Script Engine that you can use with any script that:
 - You define.
 - Cambium supplies.
- Configurability of any of the following to be the file server for image files:
 - The AP/BHM, for traditional file serving via UDP commands and monitoring via UDP messaging
 - CNUT HTTP/HTTPS Server, for upgrading via SNMP commands and monitoring via SNMP messaging. This also supports an option to either set the image order specifically for this file server or to allow the AP to determine the order.
 - Local TFTP Server, for traditional file serving via UDP commands and monitoring via UDP messaging. This supports setting the number of simultaneous image transfers per AP/BHM
- The capability to launch a test of connectivity and operational status of the local HTTP, HTTPS and TFTP file servers
- An interface that supports efficient specification of the proper IP address for the local file server(s) where Network Updater resides on a multi-homed computer
- An md5 checksum calculator utility for identifying corruption of downloaded image files before Network Updater is set to apply them.

Network element groups

With the Canopy Network Updater Tool, you can identify element groups composed of network elements that you select. Identifying these element groups does the following:

- Organizes the display of elements (for example, by region or by AP/BHM cluster).
- Allows to:
 - Perform an operation on all elements in the group simultaneously.
 - Set group-level defaults for ftp password access and SNMP Community String (defaults that can be overridden in an individual element when necessary).

Network layers

A typical network contains multiple layers of elements, with each layer farther from the Point of Presence. For example, SMs (or BHS) are behind an AP/BHM and thus, in this context, at a lower layer than the AP/BHM. Correctly portraying these layers in Network Updater is essential so that Network Updater can perform radio and AP/BHM cluster upgrades in an appropriate order.

Script engine

Script Engine is the capability in Network Updater that executes any user-defined script against any network element or element group. This capability is useful for network management, especially for scripts that you repetitively execute across your network.

The Autodiscovery capability in Network Updater finds all of your network elements. This comprehensive discovery:

- Ensures that, when you intend to execute a script against *all* elements, the script is indeed executed against *all* elements.
- Maintains master lists of elements (element groups) against which you selectively execute scripts.

The following scripts are included with CNUT:

- Gather Customer Support Information
- Set Access Point Authentication Mode
- Set Autoupdate Address on APs/BHMs
- Set SNMP Accessibility
- Reset Unit

Software dependencies for CNUT

CNUT functionality requires

- one of the following operating systems
 - Windows® 2000
 - Windows Server 2003
 - Windows 7 and Windows 8
 - Windows XP or XP Professional
 - Red Hat Enterprise Linux (32-bit) Version 4 or 5
- Java™ Runtime Version 2.0 or later (installed by the CNUT installation tool)

CNUT download

CNUT can be downloaded together with each system release that supports CNUT. Software for these system releases is available from <http://www.cambiumnetworks.com/support/management-tools/cnut/>, as either:

- A .zip file for use without the CNUT application.
- A .pkg file that the CNUT application can open.

Upgrading a module prior to deployment

To upgrade to a new software version, follow this:

Procedure 19 Upgrading a module prior to deployment

- 1 Go to the support website (see [Contacting Cambium Networks](#) on page 1) and find Point-to-Multipoint software updates. Download and save the required software image.
- 2 Start CNUT
- 3 If you don't start up with a blank new network file in CNUT, then open a new network file with the **New Network Archive** operation (located at **File > New Network**).
- 4 Enter a new network element to the empty network tree5-9 using the **Add Elements to Network Root** operation (located at **Edit > Add Elements to Network Root**).
- 5 In the **Add Elements** dialogue, select a type of **Access Point** or **Subscriber Module** and enter the IP address of **169.254.1.1**.
- 6 Make sure that the proper Installation Package is active with the **Package Manager** dialogue (located at **Update > Manage Packages**).
- 7 To verify connectivity with the radio, perform a **Refresh, Discover Entire Network** operation (located at **View > Refresh/Discover Entire Network**). You must see the details columns for the new element filled in with ESN and software version information.
- 8 Initiate the upgrade of the radio using **Update Entire Network Root** operation (located at **Update > Update Entire Network Root**). When this operation finishes, the radio is done being upgraded.

General configuration

The **Configuration > General** page of the AP/BMH or BHM/BHS contains many of the configurable parameters that define how the ratio's operate in sector or backhaul.

Applicable products **PMP :** AP SM **PTP:** BHM BMS

PMP 450m and PMP/PTP 450i Series

General page - PMP 450i AP



The General page of AP is explained in [Table 122](#).

Table 122 General page attributes – PMP 450i AP

Link Speeds	
Ethernet Port Selection :	SFP Port
Link Speed :	Auto 1000F/100F/100H/10F/10H
Bandwidth Configuration Source	
Configuration Source :	SM
Sync Setting	
Sync Input :	Generate Sync
Free Run Before GPS Sync :	<input type="radio"/> Enabled <input checked="" type="radio"/> Disabled
Region Settings	
Region :	Other - Regulatory
Country :	Other
Web Page Configuration	
Webpage Auto Update :	1 Seconds (0 = Disable Auto Update)
Bridge Configuration	
Bridge Entry Timeout :	25 Minutes (Range : 25—1440 Minutes)
Translation Bridging :	<input type="radio"/> Enabled <input checked="" type="radio"/> Disabled
Send Untranslated ARP :	<input type="radio"/> Enabled <input checked="" type="radio"/> Disabled
SM Isolation :	Disable SM Isolation
Forward Unknown Unicast Packets :	<input type="radio"/> Enabled - If destination address is not known, forward packet to all SMs. <input checked="" type="radio"/> Disabled - If destination address is not known, drop packet.
Update Application Information	
Update Application Address :	10.110.32.27
TCP Settings	
Prioritize TCP ACK :	<input checked="" type="radio"/> Enabled <input type="radio"/> Disabled

Update Application Information		
Update Application Address :	0.0.0.0	
TCP Settings		
Prioritize TCP ACK :	<input checked="" type="radio"/> Enabled	<input type="radio"/> Disabled
Layer 2 Discovery Destination Address		
Multicast Destination Address :	<input type="radio"/> Broadcast	<input checked="" type="radio"/> LLDP Multicast
DHCP Relay Agent		
DHCP Relay Agent :	Disable	
DHCP Server (Name or IP Address) :	<input type="radio"/> Append DNS Domain Name	<input checked="" type="radio"/> Disable DNS Domain Name
	255.255.255.255	
Coordinates		
Latitude :	+0.000000	Decimal Degree
Longitude :	+0.000000	Decimal Degree
Height :	0	Meters

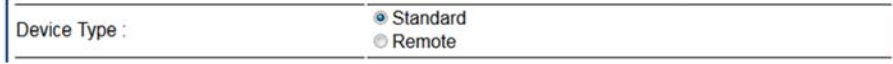
Attribute	Meaning		
Ethernet Port Selection	<p>Ethernet Port selection is applicable to the 450m platform only with two choices in the drop-down list:</p> <ul style="list-style-type: none"> • Main: A selection of main indicates that link connectivity and power to the 450m is provided through the RF45 connection on the Main port of the AP • SFP: A selection of SFP indicates that link connectivity will be provided through the SFP port on the 450m <p>Power continues to be provided via the RJ45 Main port</p>		
Link Speeds	<p>From the drop-down list of options, select the type of link speed for the Ethernet connection. The Auto settings allow the two ends of the link to automatically negotiate with each other the best possible speed, and check whether the Ethernet traffic is full duplex or half duplex.</p> <p>However, some Ethernet links work best when either:</p> <ul style="list-style-type: none"> • both ends are set to the same forced selection • both ends are set to auto-negotiate and both have capability in least one common speed and traffic type combination. 		
802.3at Type 2 PoE Status and PoE Classification (PMP 450i Series only)	<p>When the PoE Classification functionality is enabled and if Type 2 power is not present, the PAs do not power up and draw too much power.</p> <p>By default, the PoE Classification feature is disabled and the PAs will power up regardless of the classification presented by the power source.</p> <p>This is supported only on 450i series devices.</p> <p>PoE Classification configuration status also can be check under home > General > Device Information tab:</p> <table border="1"> <tr> <td>802.3at Type 2 PoE Status :</td> <td>Not Present (Ignored)</td> </tr> </table>	802.3at Type 2 PoE Status :	Not Present (Ignored)
802.3at Type 2 PoE Status :	Not Present (Ignored)		
Configuration Source	See Setting the Configuration Source on page 7-203.		
Sync Input	See Configuring synchronization on page 7-97		

Device Type	<p>Standard: The Autosync mechanism will source GPS synchronization from the AP's RJ-11 port, the AP's power port, or from the device on-board GPS module.</p> <p>Remote: The Autosync mechanism will source GPS synchronization from the AP's RJ-11 port or from the device on-board GPS module.</p>
	
Region	From the drop-down list, select the region in which the radio is operating.
Country	<p>From the drop-down list, select the country in which the radio is operating. Unlike selections in other parameters, your Country selection requires a Save Changes and a Reboot cycle before it will force the context-sensitive GUI to display related options (for example, Alternate Frequency Carrier 1 and 2 in the Configuration > Radio tab).</p> <p>PMP 450i Series ODUs shipped to the United States is locked to a Region Code setting of "United States". Units shipped to regions other than the United States must be configured with the corresponding Region Code to comply with local regulatory requirements.</p> <p>Country Code settings affect the radios in the following ways:</p> <ul style="list-style-type: none"> • Maximum transmit power limiting (based on radio transmitter power plus configured antenna gain) • DFS operation is enabled based on the configured region code, if applicable <p>For more information on how transmit power limiting and DFS is implemented for each country, see the <i>PMP 450 Planning Guide</i>.</p>
Webpage Auto Update	Enter the frequency (in seconds) for the web browser to automatically refresh the web-based interface. The default setting is 0. The 0 setting causes the web-based interface to never be automatically refreshed.
Bridge Entry Timeout	Specify the appropriate bridge timeout for correct network operation with the existing network infrastructure. The Bridge Entry Timeout must be a longer period than the ARP (Address Resolution Protocol) cache timeout of the router that feeds the network.
<div style="display: flex; align-items: flex-start;">  <div> <p>Caution</p> <p>An inappropriately low Bridge Entry Timeout setting may lead to temporary loss of communication with some end users.</p> </div> </div>	
Translation Bridging	<p>Optionally, you can configure the AP to change the source MAC address in every packet it receives from its SMs to the MAC address of the SM that bridged the packet, before forwarding the packet toward the public network. If you do, then:</p> <p>Not more than 128 IP devices at any time are valid to send data to the AP from behind the SM.</p> <p>SM populates the Translation Table tab of its Statistics web page, displaying the MAC address and IP address of all the valid connected devices.</p>

	<p>Each entry in the Translation Table is associated with the number of minutes that have elapsed since the last packet transfer between the connected device and the SM.</p> <p>If 128 are connected and another attempts to connect:</p> <p>If no Translation Table entry is older than 255 minutes, the attempt is ignored.</p> <p>If an entry is older than 255 minutes, the oldest entry is removed and the attempt is successful.</p> <p>the Send Untranslated ARP parameter in the General tab of the Configuration page can be:</p> <p>Disabled, so that the AP overwrites the MAC address in Address Resolution Protocol (ARP) packets before forwarding them.</p> <p>Enabled, so that the AP forwards ARP packets regardless of whether it has overwritten the MAC address.</p> <p>When this feature is disabled, the setting of the Send Untranslated ARP parameter has no effect, because all packets are forwarded untranslated (with the source MAC address intact).</p>
Send Untranslated ARP	<p>If the Translation Bridging parameter is set to Enabled, then the Send Untranslated ARP parameter can be:</p> <p>Disabled - so that the AP will overwrite the MAC address in Address Resolution Protocol (ARP) packets before forwarding them.</p> <p>Enabled - so that the AP will forward ARP packets regardless of whether it has overwritten the MAC address.</p> <p>If the Translation Bridging parameter is set to Disabled, then the Send Untranslated ARP parameter has no effect.</p>
SM Isolation	<p>Prevent or allow SM-to-SM communication by selecting from the following drop-down menu items:</p> <p>Disable SM Isolation (the default selection). This allows full communication between SMs.</p> <p>Block SM Packets from being forwarded. This prevents both multicast/broadcast and unicast SM-to-SM communication.</p> <p>Block and Forward SM Packets to Backbone. This not only prevents multicast/broadcast and unicast SM-to-SM communication but also sends the packets, which otherwise are handled SM to SM, through the Ethernet port of the AP.</p>
Forward Unknown Unicast Packets	<p>Enabled: All unknown Unicast packets (no entry in the AP's bridge table) received via the AP's Ethernet LAN interface are forwarded to registered SMs. If the target device is situated beneath a particular SM, when the device responds the SM and AP will learn and add the device to their bridge tables so that subsequent packets to that device is bridged to the proper SM.</p> <p>Disabled: All unknown Unicast packets (no entry in the AP's bridge table) received via the AP's Ethernet LAN interface are discarded at the AP.</p>
Update Application Address	<p>Enter the address of the server to access for software updates on this AP and registered SMs.</p>

Prioritize TCP ACK	To reduce the likelihood of TCP acknowledgement packets being dropped, set this parameter to Enabled . This can improve throughput that the end user perceives during transient periods of congestion on the link that is carrying acknowledgements. This parameter, when enabled, can be particularly useful when running bi-direction FTP sessions over the link. If a link is primarily used for video surveillance, it is recommended to set this parameter to Disable .
Multicast Destination Address	Using Link Layer Discovery Protocol (LLDP), a module exchanges multicast addresses with the device to which it is wired on the Ethernet interface. Although some switches (CMM4, for example) do not pass LLDP addresses upward in the network, a radio can pass it as the value of the Multicast Destination Address parameter value in the connected device that has it populated.
DHCP Relay Agent	<p>The AP may act as a DHCP relay for SMs and CPEs underneath it. The AP will make use of the DHCP Option 82 (DHCP Relay Agent Information) from RFC 3046 when performing relay functions. The AP offers two types of DHCP relay functionality:</p> <p>Full Relay Information. Configuring the DHCP Full Relay Operation will take broadcast DHCP packets and send them to a Unicast server in unicast mode. This way the DHCP requests and replies can be routed like any other UDP packet.</p> <p>Only Insert Option 82. This option leaves the DHCP request on its broadcast domain as opposed to DHCP Full Relay Operation which will turn it into a unicast packet.</p> <p>In order to accommodate setting up pools or classes for different VLANs, the Option 82 field will include information to tell the server what VLAN the client is on.</p>
DHCP Server (Name or IP Address)	The DHCP relay server may be either a DNS name or a static IP address in dotted decimal notation. Additionally the management DNS domain name may be toggled such that the name of the DHCP relay server only needs to be specified and the DNS domain name is automatically appended to that name. The default DHCP relay server addresses is 255.255.255.255 with the appending of the DNS domain name disabled.
Latitude Longitude Height	Physical radio location data may be configured via the Latitude , Longitude and Height fields. Latitude and Longitude is measured in <i>Decimal Degree</i> while the Height is calculated in <i>Meters</i> .

General page - PMP 450m AP

The General page of AP is explained in Table 123.

Table 123 General page attributes –PMP 450m AP

MU-MIMO	
Trial Mode	<input checked="" type="radio"/> Enabled <input type="radio"/> Disabled
Link Speeds	
Ethernet Port Selection :	SFP Port
Link Speed :	Auto 1000F/100F/100H/10F/10H
Bandwidth Configuration Source	
Configuration Source :	SM
Sync Setting	
Sync Input :	Generate Sync
Free Run Before GPS Sync :	<input type="radio"/> Enabled <input checked="" type="radio"/> Disabled
Region Settings	
Region :	Other - Regulatory
Country :	Other
Web Page Configuration	
Webpage Auto Update :	1 Seconds (0 = Disable Auto Update)
Bridge Configuration	
Bridge Entry Timeout :	25 Minutes (Range : 25—1440 Minutes)
Translation Bridging :	<input type="radio"/> Enabled <input checked="" type="radio"/> Disabled
Send Untranslated ARP :	<input type="radio"/> Enabled <input checked="" type="radio"/> Disabled
SM Isolation :	Disable SM Isolation
Forward Unknown Unicast Packets :	<input type="radio"/> Enabled - If destination address is not known, forward packet to all SMs. <input checked="" type="radio"/> Disabled - If destination address is not known, drop packet.
Update Application Information	
Update Application Address :	10.110.32.27
TCP Settings	
Prioritize TCP ACK :	<input checked="" type="radio"/> Enabled <input type="radio"/> Disabled

Update Application Information		
Update Application Address :	0.0.0.0	
TCP Settings		
Prioritize TCP ACK :	<input checked="" type="radio"/> Enabled <input type="radio"/> Disabled	
Layer 2 Discovery Destination Address		
Multicast Destination Address :	<input type="radio"/> Broadcast <input checked="" type="radio"/> LLDP Multicast	
DHCP Relay Agent		
DHCP Relay Agent :	Disable	
DHCP Server (Name or IP Address) :	<input type="radio"/> Append DNS Domain Name <input checked="" type="radio"/> Disable DNS Domain Name 255.255.255.255	
Coordinates		
Latitude :	+0.000000	Decimal Degree
Longitude :	+0.000000	Decimal Degree
Height :	0	Meters

Attribute	Meaning
Trial Mode	This parameters allows to enable or disable Trial mode for radios with a Limited key. Once the trial key is applied, the 30-day trial can be enabled or disabled at any time.

For information about remaining attributes, refer [Table 122](#).

General page - PMP 450i SM

The General page of PMP 450i SM is explained in [Table 124](#). The General page of PMP 450 SM looks the same as PMP 450i SM.

Table 124 General page attributes – PMP 450i SM

Link Speeds		
Link Speed :	Auto 1000F/100F/100H/10F/10H	
Ethernet Link :	<input checked="" type="radio"/> Enabled <input type="radio"/> Disabled	
PoE		
802.3at Type 2 PoE Status :	Present	
PoE Classification :	<input type="radio"/> Enabled <input checked="" type="radio"/> Disabled	
Region Settings		
Region :	North America	
Country :	United States	
Web Page Configuration		
Webpage Auto Update :	1 Seconds (0 = Disable Auto Update)	
Web Customizations		
Show Idle Sessions :	<input checked="" type="radio"/> Enabled <input type="radio"/> Disabled	
Bridge Configuration		
Bridge Entry Timeout :	25 Minutes (Range : 25—1440 Minutes)	
Bridge Table Size :	4096 (Range : 4—4096) (Note: 2 entries in the bridge table are used for internal purpose)	
Bridge Table Restriction :	<input type="radio"/> Drop packets if MAC address is not in bridge table <input checked="" type="radio"/> Forward packets even if MAC address is not in bridge table	
Frame Timing		
Frame Timing Pulse Gated :	<input checked="" type="radio"/> Enable (if SM out of sync then do not propagate the frame timing pulse) <input type="radio"/> Disable (Always propagate the frame timing pulse)	
Layer 2 Discovery Destination Address		
Multicast Destination Address :	<input type="radio"/> Broadcast <input checked="" type="radio"/> LLDP Multicast	
Coordinates		
Latitude :	+12.989002	Decimal Degree
Longitude :	+77.727370	Decimal Degree
Height :	10	Meters

Attribute	Meaning
Link Speeds	From the drop-down list of options, select the type of link speed for the Ethernet connection. The default for this parameter is that all speeds are selected. The recommended setting is a single speed selection for all APs and SMs in the operator network.
802.3at Type 2 PoE Status and PoE Classification	When the PoE Classification functionality is enabled and if Type 2 power is not present, the Pas do not power up and draw too much power. By default, the PoE Classification feature is disabled and the Pas will power up regardless of the classification presented by the power source. This is supported only on 450i series ODUs. PoE Classification configuration status also can be check under home > General > Device Information tab:

	802.3at Type 2 PoE Status :	Not Present (Ignored)
Ethernet Link Enable/Disable	<p>Specify whether to enable or disable Ethernet/802.3 connectivity on the wired port of the SM. This parameter has no effect on the wireless link. When you select Enable, this feature allows traffic on the Ethernet/802.3 port. This is the factory default state of the port. When you select Disable, this feature prevents traffic on the port. Typical cases of when you may want to select Disable include:</p> <p>The subscriber is delinquent with payment(s).</p> <p>You suspect that the subscriber is sending or flooding undesired broadcast packets into the network, such as when</p> <ul style="list-style-type: none"> • a virus is present in the subscriber's computing device. • the subscriber's home router is improperly configured. 	
Region	<p>This parameter allows you to set the region in which the radio will operate. The SM radio automatically inherits the Region type of the master. This behavior ignores the value of the Region parameter in the SM, even when the value is None. Nevertheless, since future system software releases may read the value in order to configure some other region-sensitive feature(s), this parameter must be always set to the value that corresponds to the local region.</p>	
Country	<p>This parameter allows you to set the country in which the radio will operate. The SM radio automatically inherits the Country Code type of the master. This behavior ignores the value of the Country parameter in the SM, even when the value is None. Nevertheless, since future system software releases may read the value in order to configure some other region-sensitive feature(s), this parameter must be always set to the value that corresponds to the local region.</p> <p>PMP/PTP 450i Series ODU shipped to the United States is locked to a Region Code setting of "United States". Units shipped to regions other than the United States must be configured with the corresponding Region Code to comply with local regulatory requirements.</p>	
Webpage Auto Update	<p>See Table 122 General page attributes – PMP 450i AP on page 7-68</p>	
Show Idle Sessions	<p>This parameter allows to enable or disable displaying idle sessions.</p>	
Bridge Entry Timeout	<p>Specify the appropriate bridge timeout for correct network operation with the existing network infrastructure. Timeout occurs when the AP encounters no activity with the SM (whose MAC address is the bridge entry) within the interval that this parameter specifies. The Bridge Entry Timeout must be a longer period than the ARP (Address Resolution Protocol) cache timeout of the router that feeds the network.</p>	

**Caution**

This parameter governs the timeout interval, even if a router in the system has a longer timeout interval. The default value of this field is 25 (minutes).

An inappropriately low Bridge Entry Timeout setting may lead to temporary loss of communication with some end users.

Bridge Table Size

This parameter allows to restrict devices to connect to the SM. It is configurable from 4 to 4096.

**Note**

Configure **Bridge Table Restriction** parameter to **Drop packets if MAC address is not in bridge table** option to restrict the number of devices configured from connecting to SM.

Bridge Table Restriction

This parameter allows to either allow or restrict devices to connect to SM using the following options:

- Drop packets if MAC address is not in bridge table: Select this option to restrict communication from devices not listed in bridge table.
- Forward packets even if MAC address is not in bridge table: Select this option to allow communication from any device.

Frame Timing Pulse Gated

If this SM extends the sync pulse to a BH master or an AP, select either

Enable—If this SM loses sync from the AP, then *do not* propagate a sync pulse to the BH timing master or other AP. This setting prevents interference in the event that the SM loses sync.

Disable—If this SM loses sync from the AP, then propagate the sync pulse to the BH timing master or other AP.

Multicast Destination Address

Using Link Layer Discovery Protocol (LLDP), a module exchanges multicast addresses with the device to which it is wired on the Ethernet interface. Although some switches (CMM4, for example) do not pass LLDP addresses upward in the network, a radio can pass it as the value of the **Multicast Destination Address** parameter value in the connected device that has it populated.

Coordinates

Physical radio location data may be configured via the **Latitude**, **Longitude** and **Height** fields.

General page - PTP 450i BHM

The General page of BHM is explained in [Table 125](#). The General page of PTP 450 BHM looks the same as PTP 450i BHM.

Table 125 General page attributes – PTP 450i BHM

Device Type	
Timing Mode :	<input checked="" type="radio"/> Timing Master <input type="radio"/> Timing Slave
Link Speeds	
Link Speed :	Auto 1000F/100F/100H/10F/10H ▼
PoE	
802.3at Type 2 PoE Status :	Not Present (Ignored)
PoE Classification :	<input type="radio"/> Enabled <input checked="" type="radio"/> Disabled
Sync Setting	
Sync Input :	Generate Sync ▼
Free Run Before GPS Sync :	<input type="radio"/> Enabled <input checked="" type="radio"/> Disabled
Region Settings	
Region :	Other - Regulatory ▼
Country :	Other ▼
Web Page Configuration	
Webpage Auto Update :	1 Seconds (0 = Disable Auto Update)
Bridge Configuration	
Bridge Entry Timeout :	25 Minutes (Range : 25—1440 Minutes)
Bridging Functionality :	<input type="radio"/> Disable <input checked="" type="radio"/> Enable
Update Application Information	
Update Application Address :	10.110.32.27
TCP Settings	
Prioritize TCP ACK :	<input checked="" type="radio"/> Enabled <input type="radio"/> Disabled
Layer 2 Discovery Destination Address	
Multicast Destination Address :	<input type="radio"/> Broadcast <input checked="" type="radio"/> LLDP Multicast
Coordinates	
Latitude :	+0.000000 Decimal Degree
Longitude :	+0.000000 Decimal Degree
Height :	0 Meters

Attribute	Meaning		
Timing Mode	Allows the user to choose the mode between Timing Master and Timing Slave.		
Link Speed	See Table 122 General page attributes – PMP 450i AP on page 7-68		
802.3at Type 2 PoE Status and PoE Classification	<p>When the PoE Classification functionality is enabled and if Type 2 power is not present, the PAs do not power up and draw too much power.</p> <p>By default, the PoE Classification feature is disabled and the PAs will power up regardless of the classification presented by the power source. This is supported only on 450i Series ODUs.</p> <p>PoE Classification configuration status also can be check under home > General > Device Information tab:</p> <table border="1"> <tr> <td>802.3at Type 2 PoE Status :</td> <td>Not Present (Ignored)</td> </tr> </table>	802.3at Type 2 PoE Status :	Not Present (Ignored)
802.3at Type 2 PoE Status :	Not Present (Ignored)		
Sync Input	See Configuring synchronization on page 7-97		
Region			
Country	See Table 122 General page attributes – PMP 450i AP on page 7-68		
Webpage Auto Update			
Bridge Entry Timeout			
Bridging Functionality	<p>Select whether you want bridge table filtering active (Enable) or not (Disable) on this BH.</p> <p>Disable: allows user to use redundant BHs without causing network addressing problems. Through a spanning tree protocol, this reduces the convergence time from 25 minutes to few seconds. However, you must disable bridge table filtering as only a deliberate part of your overall network design since disabling it allows unwanted traffic across the wireless interface.</p> <p>Enable: Allows user to enable bridge functionality.</p>		
	<p> Note</p> <p>Specify the appropriate bridge timeout for correct network operation with the existing network infrastructure. The Bridge Entry Timeout must be a longer period than the ARP (Address Resolution Protocol) cache timeout of the router that feeds the network.</p>		
Prioritize TCP ACK			
Multicast Destination Address	See Table 122 General page attributes – PMP 450i AP on page 7-68		
Latitude			
Longitude			
Height			

General page - PTP 450i BHS

The General page of PTP 450i BHS is explained in [Table 126](#). The General page of PTP 450 BHS looks the same as PTP 450i BHS.

Table 126 General page attributes – PTP 450i BHS

Device Type		
Timing Mode :	<input type="radio"/> Timing Master <input checked="" type="radio"/> Timing Slave	
Link Speeds		
Link Speed :	Auto 1000F/100F/100H/10F/10H ▾	
PoE		
802.3at Type 2 PoE Status :	Not Present (Ignored)	
PoE Classification :	<input type="radio"/> Enabled <input checked="" type="radio"/> Disabled	
Region Settings		
Region :	Other - Regulatory ▾	
Country :	Other ▾	
Web Page Configuration		
Webpage Auto Update :	1	Seconds (0 = Disable Auto Update)
Bridge Configuration		
Bridge Entry Timeout :	25	Minutes (Range : 25—1440 Minutes)
Bridging Functionality :	<input type="radio"/> Disable <input checked="" type="radio"/> Enable	
Frame Timing		
Frame Timing Pulse Gated :	<input checked="" type="radio"/> Enable (If SM out of sync then do not propagate the frame timing pulse) <input type="radio"/> Disable (Always propagate the frame timing pulse)	
Layer 2 Discovery Destination Address		
Multicast Destination Address :	<input type="radio"/> Broadcast <input checked="" type="radio"/> LLDP Multicast	
Coordinates		
Latitude :	+0.000000	Decimal Degree
Longitude :	+0.000000	Decimal Degree
Height :	0	Meters

Attribute	Meaning
Timing Mode	Allows the user to choose the mode between Timing Master and Timing Slave.
Link Speed	From the drop-down list of options, select the type of link speed for the Ethernet connection. The default for this parameter is that all speeds are selected. The recommended setting is a single speed selection for all BHM and BHSs in the operator network.

802.3at Type 2 PoE Status and PoE Classification	<p>When the PoE Classification functionality is enabled and if Type 2 power is not present, the PAs do not power up and draw too much power.</p> <p>By default, the PoE Classification feature is disabled and the PAs will power up regardless of the classification presented by the power source.</p> <p>This is supported only on 450i Series ODUs.</p> <p>PoE Classification configuration status also can be check under home > General > Device Information tab:</p>		
<hr/> <table border="1" style="width: 100%; border-collapse: collapse;"> <tr> <td style="width: 60%; padding: 2px;">802.3at Type 2 PoE Status :</td> <td style="padding: 2px;">Not Present (Ignored)</td> </tr> </table> <hr/>		802.3at Type 2 PoE Status :	Not Present (Ignored)
802.3at Type 2 PoE Status :	Not Present (Ignored)		
Region	<p>This parameter allows you to set the region in which the radio will operate.</p> <p>The BHS radio automatically inherits the Region type of the master. This behavior ignores the value of the Region parameter in the BHS, even when the value is None. Nevertheless, since future system software releases may read the value in order to configure some other region-sensitive feature(s), this parameter must be always set to the value that corresponds to the local region.</p>		
Country	<p>This parameter allows you to set the country in which the radio will operate.</p> <p>The BHS radio automatically inherits the Country Code type of the master. This behavior ignores the value of the Country parameter in the BHS, even when the value is None. Nevertheless, since future system software releases may read the value in order to configure some other region-sensitive feature(s), this parameter must be always set to the value that corresponds to the local region.</p> <p>PMP/PTP 450i Series ODU shipped to the United States is locked to a Region Code setting of "United States". Units shipped to regions other than the United States must be configured with the corresponding Region Code to comply with local regulatory requirements.</p>		
Webpage Auto Update	<p>See Table 122 General page attributes – PMP 450i AP on page 7-68</p>		
Bridge Entry Timeout	<p>Specify the appropriate bridge timeout for correct network operation with the existing network infrastructure. Timeout occurs when the BHM encounters no activity with the BHS (whose MAC address is the bridge entry) within the interval that this parameter specifies. The Bridge Entry Timeout must be a longer period than the ARP (Address Resolution Protocol) cache timeout of the router that feeds the network.</p>		
<div style="display: flex; align-items: flex-start;"> <div style="margin-right: 10px;">  </div> <div> <p>Caution</p> <p>This parameter governs the timeout interval, even if a router in the system has a longer timeout interval. The default value of this field is 25 (minutes).</p> <p>An inappropriately low Bridge Entry Timeout setting may lead to temporary loss of communication with some end users.</p> </div> </div>			
Bridging Functionality	<p>See Table 122 General page attributes – PMP 450i AP on page 7-68</p>		
Frame Timing Pulse Gated	<p>If this BHS extends the sync pulse to a BH master or an BHM, select either</p>		

	<p>Enable—If this BHS loses sync from the BHM, then <i>do not</i> propagate a sync pulse to the BH timing master or other BHM. This setting prevents interference in the event that the BHS loses sync.</p> <p>Disable—If this BHS loses sync from the BHM, then propagate the sync pulse to the BH timing master or other BHM.</p>
Multicast Destination Address	See Table 122 General page attributes – PMP 450i AP on page 7-68
Latitude	See Table 122 General page attributes – PMP 450i AP on page 7-68
Longitude	
Height	

General page - PMP 450b SM

The General page of PMP 450b SM is explained in Table 127. The General page of PMP 450b SM looks the same as PMP 450i SM.

Table 127 General page attributes – PMP 450i SM

Link Speeds	
Link Speed :	Auto 1000F/100F/100H/10F/10H ▾
Ethernet Link :	<input checked="" type="radio"/> Enabled <input type="radio"/> Disabled

Region Settings	
Region :	Other - Regulatory ▾
Country :	Other ▾

Web Page Configuration	
Webpage Auto Update :	1 Seconds (0 = Disable Auto Update)



Bridge Configuration	
Bridge Entry Timeout :	25 Minutes (Range : 25—1440 Minutes)
Bridge Table Size :	4096 (Range : 4—4096) (Note: 2 entries in the bridge table are used for internal purpose)
Bridge Table Restriction :	<input type="radio"/> Drop packets if MAC address is not in bridge table <input checked="" type="radio"/> Forward packets even if MAC address is not in bridge table

Frame Timing	
Frame Timing Pulse Gated :	<input checked="" type="radio"/> Enable (If SM out of sync then do not propagate the frame timing pulse) <input type="radio"/> Disable (Always propagate the frame timing pulse)

Layer 2 Discovery Destination Address	
Multicast Destination Address :	<input type="radio"/> Broadcast <input checked="" type="radio"/> LLDP Multicast

Coordinates	
Latitude :	+33.055571 Decimal Degree
Longitude :	-96.795068 Decimal Degree
Height :	0 Meters

Attribute	Meaning
Link Speed	From the drop-down list of options, select the type of link speed for the Ethernet connection. The default for this parameter is that all speeds are selected. The recommended setting is a single speed selection for all APs and SMs in the operator network.
Ethernet Link Enabled/Disbaled	<p>Specify whether to enable or disable Ethernet/802.3 connectivity on the wired port of the SM. This parameter has no effect on the wireless link. When you select Enable, this feature allows traffic on the Ethernet/802.3 port. This is the factory default state of the port. When you select Disable, this feature prevents traffic on the port. Typical cases of when you may want to select Disable include:</p> <p>The subscriber is delinquent with payment(s).</p> <p>You suspect that the subscriber is sending or flooding undesired broadcast packets into the network, such as when</p> <ul style="list-style-type: none"> • a virus is present in the subscriber's computing device. <p>the subscriber's home router is improperly configured.</p>
Region	<p>This parameter allows you to set the region in which the radio will operate. The SM radio automatically inherits the Region type of the master. This behavior ignores the value of the Region parameter in the SM, even when the value is None. Nevertheless, since future system software releases may read the value in order to configure some other region-sensitive feature(s), this parameter must be always set to the value that corresponds to the local region.</p>
Country	<p>This parameter allows you to set the country in which the radio will operate. The SM radio automatically inherits the Country Code type of the master. This behavior ignores the value of the Country parameter in the SM, even when the value is None. Nevertheless, since future system software releases may read the value in order to configure some other region-sensitive feature(s), this parameter must be always set to the value that corresponds to the local region.</p> <p>PMP/PTP 450i Series ODU shipped to the United States is locked to a Region Code setting of "United States". Units shipped to regions other than the United States must be configured with the corresponding Region Code to comply with local regulatory requirements.</p>
Webpage Auto Update	Enter the frequency (in seconds) for the web browser to automatically refresh the web-based interface. The default setting is 0. The 0 setting causes the web-based interface to never be automatically refreshed.

Bridge Entry Timeout	Specify the appropriate bridge timeout for correct network operation with the existing network infrastructure. Timeout occurs when the AP encounters no activity with the SM (whose MAC address is the bridge entry) within the interval that this parameter specifies. The Bridge Entry Timeout must be a longer period than the ARP (Address Resolution Protocol) cache timeout of the router that feeds the network.
	<p>Caution</p> <p>This parameter governs the timeout interval, even if a router in the system has a longer timeout interval. The default value of this field is 25 (minutes).</p> <p>An inappropriately low Bridge Entry Timeout setting may lead to temporary loss of communication with some end users.</p>
Bridge Table Size	This parameter allows to restrict devices to connect to the SM. It is configurable from 4 to 4096.
	<p>Note</p> <p>Configure Bridge Table Restriction parameter to Drop packets if MAC address is not in bridge table option to restrict the number of devices configured from connecting to SM.</p>
Bridge Table Restriction	<p>This parameter allows to either allow or restrict devices to connect to SM using the following options:</p> <ul style="list-style-type: none"> Drop packets if MAC address is not in bridge table: Select this option to restrict communication from devices not listed in bridge table. <p>Forward packets even if MAC address is not in bridge table: Select this option to allow communication from any device.</p>
Frame Timing Pulse Gated	<p>If this SM extends the sync pulse to a BH master or an AP, select either</p> <p>Enable—If this SM loses sync from the AP, then <i>do not</i> propagate a sync pulse to the BH timing master or other AP. This setting prevents interference in the event that the SM loses sync.</p> <p>Disable—If this SM loses sync from the AP, then propagate the sync pulse to the BH timing master or other AP.</p>
Multicast Destination Address	<p>Using Link Layer Discovery Protocol (LLDP), a module exchanges multicast addresses with the device to which it is wired on the Ethernet interface. Although some switches (CMM4, for example) do not pass LLDP addresses upward in the network, a radio can pass it as the value of the Multicast Destination Address parameter value in the connected device that has it populated.</p>
Latitude Longitude Height	<p>Physical radio location data may be configured via the Latitude, Longitude and Height fields.</p> <p>Latitude and Longitude is measured in <i>Decimal Degree</i> while the Height is calculated in <i>Meters</i>.</p>

PMP/PTP 450 Series



Note

Refer [Table 122](#) and [Table 124](#) for PMP 450 AP/SM General page parameters details.

General page - PMP 450 AP

Figure 133 General page attributes - PMP 450 AP

Device Type		
Device Setting :	<input checked="" type="radio"/> AP <input type="radio"/> SM	
Link Speeds		
Link Speed :	Auto 100F/100H/10F/10H	
Bandwidth Configuration Source		
Configuration Source :	SM	
Sync Setting		
Sync Input :	AutoSync	
AP Type :	<input checked="" type="radio"/> Standard AP <input type="radio"/> Remote AP	
Region Settings		
Region :	Other - Regulatory	
Country :	Other - FCC	
Web Page Configuration		
Webpage Auto Update :	5 Seconds (0 = Disable Auto Update)	
Bridge Configuration		
Bridge Entry Timeout :	25 Minutes (Range : 25—1440 Minutes)	
Translation Bridging :	<input type="radio"/> Enabled <input checked="" type="radio"/> Disabled	
Send Untranslated ARP :	<input type="radio"/> Enabled <input checked="" type="radio"/> Disabled	
SM Isolation :	Disable SM Isolation	
Packet Flooding :	<input type="radio"/> Bridge Flooding Enabled - Forward unknown unicast packets to all SMs. <input checked="" type="radio"/> Bridge Flooding Disabled - Only forward learned unicast packets.	
Update Application Information		
Update Application Address :	0.0.0.0	
TCP Settings		
Prioritize TCP ACK :	<input checked="" type="radio"/> Enabled <input type="radio"/> Disabled	
Layer 2 Discovery Destination Address		
Multicast Destination Address :	<input type="radio"/> Broadcast <input checked="" type="radio"/> LLDP Multicast	
DHCP Relay Agent		
DHCP Relay Agent :	Disable	
DHCP Server (Name or IP Address) :	<input type="radio"/> Append DNS Domain Name <input checked="" type="radio"/> Disable DNS Domain Name 255.255.255.255	
Coordinates		
Latitude :	+0.000000	Decimal Degree
Longitude :	+0.000000	Decimal Degree
Height :	0	Meters

General page - PMP 450 SM

Figure 134 General page attributes - PMP 450 SM

Link Speeds		
Link Speed :	Auto 100F/100H/10F/10H ▾	
Ethernet Link :	<input checked="" type="radio"/> Enabled <input type="radio"/> Disabled	

Region Settings		
Region :	Other - Regulatory ▾	
Country :	Other ▾	

Web Page Configuration		
Webpage Auto Update :	1	Seconds (0 = Disable Auto Update)

Bridge Configuration		
Bridge Entry Timeout :	25	Minutes (Range : 25—1440 Minutes)
Bridge Table Size :	4	(Range : 4—4096) (Note: 2 entries in the bridge table are used for internal purpose)
Bridge Table Restriction :	<input type="radio"/> Drop packets if MAC address is not in bridge table <input checked="" type="radio"/> Forward packets even if MAC address is not in bridge table	

Frame Timing		
Frame Timing Pulse Gated :	<input checked="" type="radio"/> Enable (If SM out of sync then do not propagate the frame timing pulse) <input type="radio"/> Disable (Always propagate the frame timing pulse)	

Layer 2 Discovery Destination Address		
Multicast Destination Address :	<input type="radio"/> Broadcast <input checked="" type="radio"/> LLDP Multicast	

Coordinates		
Latitude :	+0.000000	Decimal Degree
Longitude :	+0.000000	Decimal Degree
Height :	0	Meters

General page – PTP 450 BHM

Figure 135 General page attributes - PTP 450 BHM

Device Type	
Timing Mode :	<input checked="" type="radio"/> Timing Master <input type="radio"/> Timing Slave

Link Speeds	
Link Speed :	Auto 100F/100H/10F/10H ▼

Sync Setting	
Sync Input :	Generate Sync ▼

Regional Settings	
Region :	North America ▼
Country :	United States ▼

Web Page Configuration	
Webpage Auto Update :	1 Seconds (0 = Disable Auto Update)

Bridge Configuration	
Bridge Entry Timeout :	25 Minutes (Range : 25—1440 Minutes)
Bridging Functionality :	<input type="radio"/> Disable <input checked="" type="radio"/> Enable

Update Application Information	
Update Application Address :	0.0.0.0

TCP Settings	
Prioritize TCP ACK :	<input checked="" type="radio"/> Enabled <input type="radio"/> Disabled

Layer 2 Discovery Destination Address	
Multicast Destination Address :	<input type="radio"/> Broadcast <input checked="" type="radio"/> LLDP Multicast

Coordinates		
Latitude :	+0.000000	Decimal Degree
Longitude :	+0.000000	Decimal Degree
Height :	0	Meters

General page – PTP 450 BHS

Figure 136 General page attributes - PTP 450 BHS

Device Type		
Timing Mode :	<input type="radio"/> Timing Master <input checked="" type="radio"/> Timing Slave	

Link Speeds		
Link Speed :	Auto 100F/100H/10F/10H ▼	

Regional Settings		
Region :	North America ▼	
Country :	United States ▼	

Web Page Configuration		
Webpage Auto Update :	0	Seconds (0 = Disable Auto Update)

Bridge Configuration		
Bridge Entry Timeout :	25	Minutes (Range : 25—1440 Minutes)
Bridging Functionality :	<input type="radio"/> Disable <input checked="" type="radio"/> Enable	

Frame Timing		
Frame Timing Pulse Gated :	<input checked="" type="radio"/> Enable (If SM out of sync then do not propagate the frame timing pulse) <input type="radio"/> Disable (Always propagate the frame timing pulse)	

Layer 2 Discovery Destination Address		
Multicast Destination Address :	<input type="radio"/> Broadcast <input checked="" type="radio"/> LLDP Multicast	

Coordinates		
Latitude :	+0.000000	Decimal Degree
Longitude :	+0.000000	Decimal Degree
Height :	0	Meters

Configuring Unit Settings page

Applicable products **PMP :** AP SM **PTP:** BHM BMS

The **Unit Settings** page of the 450 Platform Family contains following options:

- Unit-Wide Changes
- Download Configuration File
- Upload and Apply Configuration File (for AP and BHM)
- LED Panel Settings (for SM and BHS)



Note

LED Panel setting is applicable for SM and BHS only.

Upload and Apply Configuration File attributes are not supported for SM and BHS.

The 450 Platform Family also supports import and export of configuration from the AP/BHM/SM/BHS as a text file. The configuration file is in JSON format. The logged in user must be an ADMINISTRATOR in order to export or import the configuration file.

The exported configuration file contains the complete configuration including all the default values. To keep a backup of the current configuration, the file can be saved as-is and imported later.

The configuration file supports encrypted password. The exported configuration file will contain encrypted password. The import of configuration can have either encrypted or plain text password in Configuration file. A new tab Encrypt the Password is added under Encrypted Password tab to generate encrypted password for a given password.

The Import and Export procedure of configuration file is described in [Import and Export of config file](#) on page 7-218.

LED Panel Mode has options select Revised mode and Legacy mode. The Legacy mode configures the radio to operate with standard LED behavior.

Unit Settings page of 450 Platform Family - AP/BHM

The Unit Setting page of AP/BHM is explained in [Table 128](#).

Table 128 Unit Settings attributes – 450 Platform Family AP/BHM

Attribute	Meaning
Set to Factory Defaults Upon Default Mode Detection	<p>If Enabled is checked, then the default mode functions is enabled. When the module is rebooted with Default mode enabled, it can be accessed at the IP address 169.254.1.1 and no password, and all parameter values are reset to defaults. A subscriber, technician, or other person who gains physical access to the module and uses an override <i>cannot</i> see or learn the settings that were previously configured in it.</p> <p>If Disabled is checked, then the default mode functions is disabled.</p> <p>See Radio recovery mode on page 1-26</p>
	<p> Caution</p> <p>When Set to Factory Defaults Upon Default Mode is set to Enable, the radio does not select all of the frequencies for Radio Frequency Scan Selection List. It needs to be selected manually.</p>
Undo Unit-Wide Saved Changes	When you click this button, any changes that you made in any tab but did not commit by a reboot of the module are undone.
Set to Factory Defaults	When you click this button, <i>all configurable parameters on all tabs</i> are reset to the factory settings.

**Note**

This can be reverted by selecting "Undo Unit-Wide Saved Changes", *before* rebooting the radio, though this is not recommended.

Password

This allows to provide encrypted password for a given password. On click of 'Encrypt the password' button, the Encrypted Password field will display encrypted value of entered plain text password in 'Password' field.

The screenshot shows a dialog box titled "Encrypt the Password". It contains two text input fields: "Password :" and "Encrypted Password :". The "Password" field contains several asterisks. The "Encrypted Password" field contains the string "54e06861bcf9710630513dadefb7ff8". Below the fields is a button labeled "Encrypt the password".

Configuration File

This allows to download the configuration file of the radio. This configuration file contains the complete configuration including all the default values. The configuration file is highlighted as downloadable link and the naming convention is "<mac address of AP>.cfg".

Apply Configuration File

This allows to import and apply configuration to the AP.

Chose File: Select the file to upload the configuration. The configuration file is named as "<file name>.cfg".

Upload: Import the configuration to the AP.

Apply Configuration File: Apply the imported configuration file to the AP. The imported configuration file may either contain a full device configuration or a partial device configuration. If a partial configuration file is imported, only the items contained in the file will be updated, the rest of the device configuration parameters will remain the same. Operators may also include a special flag in the configure file to instruct the device to first revert to factory defaults then to apply the imported configuration.

Status of Configuration file

This section shows the results of the upload.

Unit Settings page of PMP/PTP 450i SM/BHS

The Unit Settings page of PMP/PTP 450i SM/BHS is explained in [Table 129](#).

Table 129 SM Unit Settings attributes

Default Plug Mode	
Set To Factory Defaults Upon Default Plug Mode Detection :	<input type="radio"/> Enabled <input checked="" type="radio"/> Disabled
LED Panel Settings	
LED Panel Mode :	<input type="radio"/> Revised Mode (Optimized For Indoor SM) <input checked="" type="radio"/> Legacy Mode
Unit-Wide Changes	
<input type="button" value="Undo Unit-Wide Saved Changes"/> <input type="button" value="Set to Factory Defaults"/>	
Encrypt the Password	
Password :	<input type="text"/>
Encrypted Password :	<input type="text"/>
<input type="button" value="Encrypt the password"/>	
Download Configuration File	
Configuration File :	0a003ea0a066_cfg
Upload and Apply Configuration File	
Configuration file import is currently unsupported over the web proxy.	
Status of Configuration File	
<input type="text"/>	

Attribute	Meaning
Set to Factory Defaults Upon Default Plug Detection	See Table 128 Unit Settings attributes – 450 Platform Family AP/BHM on page 7-92
LED Panel Settings	Legacy Mode configures the radio to operate with standard LED behavior.
Undo Unit-Wide Saved Changes	
Password	
Set to Factory Defaults	See Table 128 Unit Settings attributes – 450 Platform Family AP/BHM on page 7-92
Configuration File	
Status of Configuration file	

Setting up time and date

Time page of 450 Platform Family - AP/BHM

Applicable products

PMP : AP

PTP: BHM

The Time page of 450 Platform Family AP/BHM is explained in [Table 130](#).

Table 130 450 Platform Family - AP/BHM Time attributes

NTP Server Configuration

NTP Server (Name or IP Address) : Append DNS Domain Name
 Disable DNS Domain Name

NTP Server 1 (Name or IP Address) :

NTP Server 2 (Name or IP Address) :

NTP Server 3 (Name or IP Address) :

NTP Server(s) In Use : pool.ntp.org (108.61.73.244)

Current System Time

Time Zone :

System Time : 20:33:13 06/26/2013 UTC

Last NTP Time Update : 20:32:07 06/26/2013 UTC

Time and Date

Time : : : UTC

Date : / /

NTP Update Log

06/26/2013 : 20:32:07 UTC : Clock Updated, Server 1

Attribute	Meaning
NTP Server (Name or IP Address)	The management DNS domain name may be toggled such that the name of the NTP server only needs to be specified and the DNS domain name is automatically appended to that name.
NTP Server 1 (Name or IP Address)	To have each log in the AP/BHM correlated to a meaningful time and date, either a reliable network element must pass time and date to the AP/BHM or must set the time and date whenever a power cycle of the AP/BHM has occurred. A network element passes time and date in any of the following scenarios:
NTP Server 2 (Name or IP Address)	
NTP Server 3 (Name or IP Address)	
	<ul style="list-style-type: none"> A connected CMM4 passes time and date (GPS time and date, if received). A connected CMM4 passes the time and date (GPS time and date, if received), but only if both the CMMr is operating on CMMr Release 2.1 or later release. (These releases include NTP server functionality.)

-
- A separate NTP server (including APs/BHMs receiving NTP data) is addressable from the AP/BHM.

If the AP/BHM needs to obtain time and date from a CMM4, or a separate NTP server, enter the IP address or DNS name of the CMM4 or NTP server on this tab. To force the AP/BHM to obtain time and date before the first (or next) 15-minute interval query of the NTP server, click **Get Time via NTP**.

The polling of the NTP servers is done in a sequential fashion, and the polling status of each server is displayed in the NTP Update Log section of the Time Configuration page. An entry of 0.0.0.0 in any of the NTP Server fields indicates an unused server configuration.

NTP Server(s) in Use	Lists the IP addresses of servers used for NTP retrieval.
Time Zone	The Time Zone option may be used to offset the received NTP time to match the operator's local time zone. When set on the AP/BHM, the offset is set for the entire sector SMs (or BHS) are notified of the current Time Zone upon initial registration). If a Time Zone change is applied, the SMs(or BHS) is notified of the change in a best effort fashion, meaning some SMs//BHSs may not pick up the change until the next re-registration. Time Zone changes are noted in the Event Log of the AP/BHM and SM/BHS.
System Time	The current time used by the system.
Last NTP Time Update	The last time that the system time was set via NTP.
Time	This field may be used to manually set the system time of the radio.
Date	This field may be used to manually set the system date of the radio.
NTP Update Log	This field shows NTP clock update log. It includes NTP clock update Date and Time stamp along with server name.

Configuring synchronization

Applicable products

PMP : AP

PTP: BHM

This section describe synchronization options for PMP and PTP configuration.

This **Sync Input** parameter can be configured under Sync Setting tab of **Configure > General** page (see [General configuration](#) on page 7-68).

PMP/PTP 450i Series has following synchronization options:

- AutoSync
- AutoSync + Free Run
- Generate Sync
- Free Run Before GPS Sync

Figure 137 Sync Setting configuration

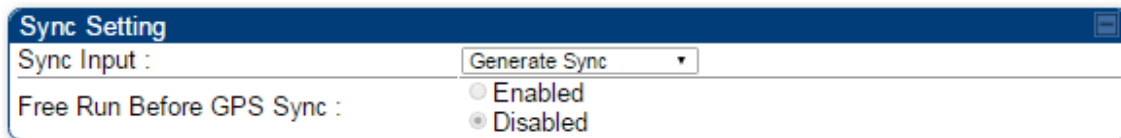

AutoSync

For PTP, the BHM automatically receives sync from one of the following sources:

- GPS Sync over Timing Port (UGPS, co-located AP GPS sync output, or “Remote ” Device feed from a registered SM’s GPS sync output)
- GPS Sync over Power Port (CMM4)

Upon AP/BM power on, the AP/BHM does not transmit until a valid synchronization pulse is received from one of the sources above. If there is a loss of GPS synchronization pulse, within two seconds the AP/BHM automatically attempts to source GPS signaling from another source.

In case of PMP, when there are synchronization sources on both the timing port and the power port, the power port GPS source is chosen first.

If no valid GPS signal is received, the AP/BHM ceases transmission and SM/BHS registration is lost until a valid GPS signal is received again on the AP or BHM.



Note

After an AP reboot, the sync acquisition takes a little longer than it had on 450i (anywhere from 40 seconds to 120 seconds difference).

AutoSync + Free Run

This mode operates similarly to mode “AutoSync”, but if a previously received synchronization signal is lost and no GPS signaling alternative is achieved, the AP/BHM automatically changes to synchronization mode “Generate Sync”. While SM registration is maintained, in this mode there is no synchronization of APs/BHMs that can “hear” each other; the AP/BHM will only generate a sync signal for the local AP/BHM and its associated SMs/BHS. Once a valid GPS signal is obtained again, the AP/BHM automatically switches to receiving synchronization via the GPS source and SM/BHS registration is maintained.

When the Sync Input field is set to Autosync or Autosync + Free Run, other options become available to be set e.g. UGPS Power and other fields. This is true on APs and BHMs.



Note

In mode AutoSync + Free Run, if a GPS signal is never achieved initially, the system will not switch to “Free Run” mode, and SMs/BHS will not register to the AP/BHM. A valid GPS signal must be present initially for the AP to switch into “Free Run” mode (and to begin self-generating a synchronization pulse).

Also, When an AP/BHM is operating in “Free Run” mode, over a short time it will no longer be synchronized with co-located or nearby APs/BHMs (within radio range). Due to this lack of transmit and receive synchronization across APs/BHMs or across systems, performance while in “Free Run” mode may be degraded until the APs/BHMs operating in “Free Run” mode regain an external GPS synchronization source. Careful attention is required to ensure that all systems are properly receiving an external GPS synchronization pulse, and please consider “Free Run” mode as an emergency option.

Generate Sync (factory default)

This option may be used when the AP/BHM is not receiving GPS synchronization pulses from either a CMM4 or UGPS module, and there are no other APs/BHMs active within the link range. Using this option will not synchronize transmission of APs/BHMs that can “hear” each other; it will only generate a sync signal for the local AP/BHM and its associated SMs/BHS.



Note

When an AP/BHM has its "Regional Code" set to "None", The radio will not provide valid Sync Pulse Information.

There is a RED warning that the radio will not transmit, but the user might expect to see a valid sync if the radio is connected to a working CMM4 or UGPS.

Configuring security

Perform this task to configure the 450 Platform system in accordance with the network operator's security policy. Choose from the following procedures:

- [Managing module access by password](#) on page 7-100: to configure the unit access password and access level
- [Isolating from the internet](#) on page 7-103: to ensure that APs are properly secured from external networks
- [Encrypting radio transmissions](#) on page 7-103: to configure the unit to operate with AES or DES wireless link security
- [Requiring SM Authentication](#) on page 7-104: to set up the AP to require SMs to authenticate via the AP, WM, or RADIUS server
- [Filtering protocols and ports](#) on page 7-105: to filter (block) specified protocols and ports from leaving the system
- [Encrypting downlink broadcasts](#) on page 7-108: to encrypt downlink broadcast transmissions
- [Isolating SMs](#) on page 7-108: to prevent SMs in the same sector from directly communicating with each other
- [Filtering management through Ethernet](#) on page 7-109: to prevent management access to the SM via the radio's Ethernet port
- [Allowing management only from specified IP addresses](#) on page 7-109: to only allow radio management interface access from specified IP addresses
- [Restricting radio Telnet access over the RF interface](#) on page 7-109: to restrict Telnet access to the AP
- [Configuring SNMP Access](#) on page 7-112
- [Configuring Security](#) on page 7-114

Managing module access by password

Applicable products **PMP :** AP SM **PTP:** BHM BMS

See [Managing module access by passwords](#) on page 3-44.

Adding a User for Access to a module

The **Account > Add User** page allows to create a new user for accessing 450 Platform Family - AP/SM/BHM/BHS. The Add User page is explained in [Table 131](#).

Table 131 Add User page of account page - AP/ SM/BH

Attribute	Meaning
User Name	User Account name.
Level	Select appropriate level for new account. It can be INSTALLER, ADMINISTRATOR or TECHNICIAN. See Managing module access by passwords on page 3-44.
New Password	Assign the password for new user account
Confirm Password	This new password must be confirmed in the “ Confirm Password ” field.
User Mode	User Mode is used to create an account which are mainly used for viewing the configurations. The local and remote Read-Only user account can be created by “Admin”, “Installer” or “Tech” logins. To create a Read-Only user, the “read-only” check box needs to be checked.



Note

The Read-Only user cannot perform any service impacting operations like creating read-only accounts, editing and viewing read-only user accounts, changes in login page, read-only user login, Telnet access, SNMP, RADIUS and upgrade/downgrade.

Deleting a User from Access to a module

The **Account > Delete User** page provides a drop down list of configured users from which to select the user you want to delete. The Delete User page is explained in [Table 132](#).

Table 132 Delete User page - 450 Platform Family - AP/ SM/BH

Attribute	Meaning
User	<p>Select a user from drop down list which has to be deleted and click Delete button.</p> <p>Accounts that cannot be deleted are</p> <ul style="list-style-type: none"> the current user's own account. the last remaining account of ADMINISTRATOR level.

Changing a User Setting

The **Account > Change User Setting** page allows to update password, mode update and general status permission for a user.

From the factory default state, configure passwords for both the root and admin account at the ADMINISTRATOR permission level, using **Update Password** tab of Change Users Setting page.

The Change User Setting page is explained in [Table 133](#).

Table 133 Change User Setting page - 450 Platform Family AP/ SM/BH

Attribute	Meaning
-----------	---------

Update Password tab	This tab provides a drop down list of configured users from which a user is selected to change password.
Update Mode tab	This tab facilitates to convert a configured user to a Read-Only user.
General Status Permission tab	This tab enables and disables visibility of General Status Page for all Guest user. To display of Radio data on SMS/BHS main Login page for Guest login, it can be enabled or disabled in Security tab of Configuration page.

Figure 138 AP Evaluation Configuration parameter of Security tab for PMP

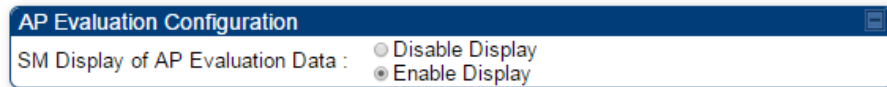
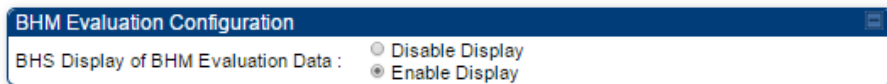

Figure 139 BHM Evaluation Configuration parameter of Security tab for PTP



Users account

The **Account > Users** page allows to view all configured users account for accessing the module.

The Users page is explained in [Table 134](#).

Table 134 User page –450 Platform Family AP/SM/BH

Username	Permission	Mode
admin	ADMINISTRATOR	Read-Write
root	ADMINISTRATOR	Read-Write
ins	INSTALLER	Read-Write

Attribute	Meaning
Username	User access account name
Permission	Permission of configured user – INSTALLER, ADMINISTRATOR or TECHNICIAN
Mode	This field indicate access mode of user – Read-Write or Read-Only.

Overriding Forgotten IP Addresses or Passwords on AP and SM

See [Radio recovery mode](#) on page 1-26

Isolating from the internet – APs/BHMs

Applicable products	PMP : <input checked="" type="checkbox"/> AP	PTP: <input checked="" type="checkbox"/> BHM
----------------------------	---	---

See [Isolating AP/BHM from the Internet](#) on page 3-42.

Encrypting radio transmissions

Applicable products	PMP : <input checked="" type="checkbox"/> AP	<input checked="" type="checkbox"/> SM	PTP: <input checked="" type="checkbox"/> BHM	<input checked="" type="checkbox"/> BMS
----------------------------	---	--	---	---

See [Encrypting radio transmissions](#) on page 3-42.

Requiring SM Authentication

Applicable products **PMP :** AP SM

Through the use of a shared AP key, or an external RADIUS (Remote Authentication Dial In User Service) server, it enhances network security by requiring SMs to authenticate when they register.

For descriptions of each of the configurable security parameters on the AP, see [Configuring Security](#) on page 7-114. For descriptions of each of the configurable security parameters on the SM, see [Security](#) on page 7-119.

Operators may use the AP's **Authentication Mode** field to select from among the following authentication modes:

- **Disabled**—the AP requires no SMs to authenticate (factory default setting).
- **Authentication Server** —the AP requires any SM that attempts registration to be authenticated in Wireless Manager before registration
- **AP PreShared Key** - The AP acts as the authentication server to its SMs and will make use of a user-configurable pre-shared authentication key. The operator enters this key on both the AP and all SMs desired to register to that AP. There is also an option of leaving the AP and SMs at their default setting of using the “Default Key”. Due to the nature of the authentication operation, if you want to set a specific authentication key, then you **MUST** configure the key on all of the SMs and reboot them **BEFORE** enabling the key and option on the AP. Otherwise, if you configure the AP first, none of the SMs is able to register.
- **RADIUS AAA** - When RADIUS AAA is selected, up to 3 Authentication Server (RADIUS Server) IP addresses and Shared Secrets can be configured. The IP address(s) configured here must match the IP address(s) of the RADIUS server(s). The shared secret(s) configured here must match the shared secret(s) configured in the RADIUS server(s). Servers 2 and 3 are meant for backup and reliability, not for splitting the database. If Server 1 doesn't respond, Server 2 is tried, and then server 3. If Server 1 rejects authentication, the SM is denied entry to the network, and does not progress trying the other servers.

For more information on configuring the PMP 450 Platform network to utilize a RADIUS server, see [Configuring a RADIUS server](#) on page 7-226.

Filtering protocols and ports

Applicable products PMP : AP SM PTP: BHM BMS

The filtering protocols and ports allows to configure filters for specified protocols and ports from leaving the AP/SM/BHM/BHS and entering the network. See [Filtering protocols and ports](#) on page 3-45.

Protocol filtering page of 450 Platform Family AP/BHM

The Protocol Filtering page of 450 Platform Family - AP/BHM is explained in [Table 135](#).

Table 135 AP/BHM Protocol Filtering attributes

Packet Filter Configuration	
Packet Filter Types :	<input checked="" type="checkbox"/> PPPoE
	<input type="checkbox"/> All IPv4
	<input type="checkbox"/> SMB (Network Neighborhood)
	<input type="checkbox"/> SNMP
	<input type="checkbox"/> Bootp Client
	<input type="checkbox"/> Bootp Server
	<input type="checkbox"/> IPv4 Multicast
	<input type="checkbox"/> User Defined Port 1 (See Below)
	<input type="checkbox"/> User Defined Port 2 (See Below)
	<input type="checkbox"/> User Defined Port 3 (See Below)
	<input type="checkbox"/> All other IPv4
	<input type="checkbox"/> All IPv6
	<input type="checkbox"/> SMB (Network Neighborhood)
	<input type="checkbox"/> SNMP
	<input type="checkbox"/> Bootp Client
<input type="checkbox"/> Bootp Server	
<input type="checkbox"/> IPv6 Multicast	
<input type="checkbox"/> All other IPv6	
<input type="checkbox"/> ARP	
<input type="checkbox"/> All others	
Filter Direction :	<input type="checkbox"/> Upstream
	<input type="checkbox"/> Downstream

User Defined Port Filtering Configuration	
Port #1 :	<input type="text" value="0"/> (Decimal Value)
TCP :	<input type="radio"/> Enabled <input checked="" type="radio"/> Disabled
UDP :	<input type="radio"/> Enabled <input checked="" type="radio"/> Disabled
Port #2 :	<input type="text" value="0"/> (Decimal Value)
TCP :	<input type="radio"/> Enabled <input checked="" type="radio"/> Disabled
UDP :	<input type="radio"/> Enabled <input checked="" type="radio"/> Disabled
Port #3 :	<input type="text" value="0"/> (Decimal Value)
TCP :	<input type="radio"/> Enabled <input checked="" type="radio"/> Disabled
UDP :	<input type="radio"/> Enabled <input checked="" type="radio"/> Disabled

AP Specialty Filters	
RF Telnet Access :	<input checked="" type="radio"/> Enabled <input type="radio"/> Disabled
PPPoE PADI Downlink Forwarding :	<input checked="" type="radio"/> Enabled <input type="radio"/> Disabled

Attribute	Meaning
Packet Filter Types	<p>For any box selected, the Protocol and Port Filtering feature blocks the associated protocol type.</p> <p>To filter packets in any of the user-defined ports, must do all of the following:</p> <p>Check the box for User Defined Port <i>n</i> (See Below) in the Packet Filter Types section of this tab.</p> <p>In the User Defined Port Filtering Configuration section of this tab:</p> <ul style="list-style-type: none"> • provide a port number at Port #<i>n</i>. • enable TCP and/or UDP by clicking the associated radio button
Filter Direction	Operators may choose to filter upstream (uplink) RF packets or downstream (downlink) RF packets.
User Defined Port Filtering Configuration	You can specify ports for which to block subscriber access, regardless of whether NAT is enabled.
RF Telnet Access	<p>RF Telnet Access restricts Telnet access to the AP/BHM from a device situated below a network SM/BHS (downstream from the AP/BHM). This is a security enhancement to restrict RF-interface sourced AP access specifically to the LAN1 IP address and LAN2 IP address (Radio Private Address, typically 192.168.101.[LUID]). This restriction disallows unauthorized users from running Telnet commands on the AP/BHM that can change AP/BHM configuration or modifying network-critical components such as routing and ARP tables.</p>
PPPoE PADI Downlink Forwarding	<p>Enabled: the AP/BHM allows downstream and upstream transmission of PPPoE PADI packets. By default, PPPoE PADI Downlink Forwarding is set to “Enabled”.</p> <p>Disabled: the AP/BHM disallows PPPoE PADI packets from entering the Ethernet interface and exiting the RF interface (downstream to the SM/BHS). PPPoE PADI packets are still allowed to enter the AP’s RF interface and exit the AP’s /BHM’s Ethernet interface (upstream).</p>

Protocol filtering page of SM/BHS

The Protocol Filtering page of SM/BHS is explained in [Table 136](#).

Table 136 SM/BHS Protocol Filtering attributes

Packet Filter Configuration

Packet Filter Types :

- PPPoE
- All IPv4
 - SMB (Network Neighborhood)
 - SNMP
 - Bootp Client
 - Bootp Server
 - IPv4 Multicast
 - User Defined Port 1 (See Below)
 - User Defined Port 2 (See Below)
 - User Defined Port 3 (See Below)
 - All other IPv4
- All IPv6
 - SMB (Network Neighborhood)
 - SNMP
 - Bootp Client
 - Bootp Server
 - IPv6 Multicast
 - All other IPv6
- ARP
- All others

Filter Direction :

- Upstream
- Downstream

User Defined Port Filtering Configuration

Port #1 :	<input type="text" value="0"/>	(Decimal Value)
TCP :	<input type="radio"/> Enabled <input checked="" type="radio"/> Disabled	
UDP :	<input type="radio"/> Enabled <input checked="" type="radio"/> Disabled	
Port #2 :	<input type="text" value="0"/>	(Decimal Value)
TCP :	<input type="radio"/> Enabled <input checked="" type="radio"/> Disabled	
UDP :	<input type="radio"/> Enabled <input checked="" type="radio"/> Disabled	
Port #3 :	<input type="text" value="0"/>	(Decimal Value)
TCP :	<input type="radio"/> Enabled <input checked="" type="radio"/> Disabled	
UDP :	<input type="radio"/> Enabled <input checked="" type="radio"/> Disabled	

Attribute	Meaning
Packet Filter Configuration tab	See Table 135 AP/BHM Protocol Filtering attributes on page 7-105
User Defined Port Filtering tab	See Table 135 AP/BHM Protocol Filtering attributes on page 7-105

Port configuration

450 Platform Family ODUs support access to various communication protocols and only the ports required for these protocols are available for access by external entities. Operators may change the port numbers for these protocols via the radio GUI or SNMP.

The **Port Configuration** page of the AP/SM/BHM/BHS is explained in [Table 137](#).

Table 137 Port Configuration attributes – AP/SM/BHM/BMS

Attribute	Meaning
FTP Port	The listen port on the device used for FTP communication.
HTTP Port	The listen port on the device used for HTTP communication.
HTTPS Port	The listen port on the device used for HTTPS communication
Radius Port	The destination port used by the device for RADIUS communication.
Radius Accounting Port	The destination port used by the device for RADIUS accounting communication.
SNMP Port	The listen port on the device used for SNMP communication.
SNMP Trap Port	The destination port used by the device to which SNMP traps are sent.
Syslog Server Port	The destination port used by the device to which Syslog messaging is sent.

Encrypting downlink broadcasts

See [Encrypting downlink broadcasts](#) on page 3-49.

Isolating SMs

See [Isolating SMs in PMP](#) on page 3-49.

Filtering management through Ethernet

See [Filtering management through Ethernet](#) on page 3-49.

Allowing management only from specified IP addresses

See [Allowing management from only specified IP addresses](#) on page 3-50.

Restricting radio Telnet access over the RF interface

RF Telnet Access restricts Telnet access to the AP from a device situated below a network SM (downstream from the AP). This is a security enhancement to restrict RF-interface sourced AP access specifically to the LAN1 IP address and LAN2 IP address (Radio Private Address, typically 192.168.101.[LUID]). This restriction disallows unauthorized users from running Telnet commands on the AP that can change AP configuration or modifying network-critical components such as routing and ARP tables.

The RF Telnet Access may be configured via the AP GUI or via SNMP commands, and RF Telnet Access is set to “Enabled” by default. Once RF Telnet Access is set to “Disabled”, if there is a Telnet session attempt to the AP originating from a device situated below the SM (or any downstream device), the attempt is dropped. This also includes Telnet session attempts originated from the SM’s management interface (if a user has initiated a Telnet session to a SM and attempts to Telnet from the SM to the AP). In addition, if there are any active Telnet connections to the AP originating from a device situated below the SM (or any downstream device), the connection is dropped. This behavior must be considered if system administrators use Telnet downstream from an AP (from a registered SM) to modify system parameters.

Setting RF Telnet Access to “Disabled” does not affect devices situated above the AP from accessing the AP via Telnet, including servers running the CNUT (Canopy Network Updater tool) application. Also, setting RF Telnet Access to “Disabled” does not affect any Telnet access into upstream devices (situated above or adjacent to the AP) through the AP (see [Figure 140](#)).

The figure below depicts a user attempting two telnet sessions. One is targeted for the AP (orange) and one is targeted for the network upstream from the AP (green). If RF Telnet Access is set to “Disabled” (factory default setting), the Telnet attempt from the user to the AP is blocked, but the attempt from the user to Network is allowed to pass through the Cambium network.

Figure 140 RF Telnet Access Restrictions (orange) and Flow through (green)

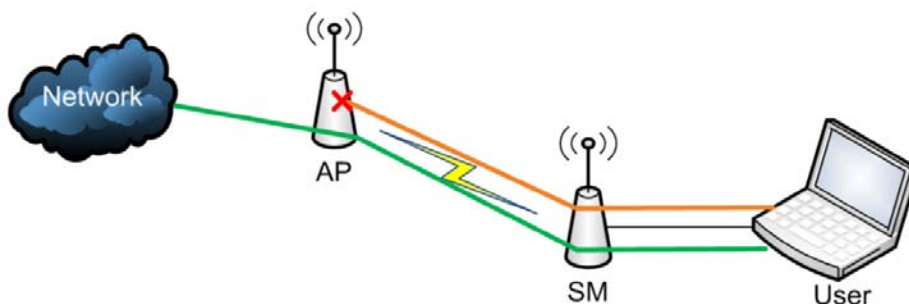

Key Security Considerations when using the RF Telnet Access Feature

To ensure that the network is fully protected from unauthorized AP Telnet sessions, the following topics must be considered:

Securing AP Clusters

When working with a cluster of AP units, to eliminate potential security holes allowing Telnet access, ensure that the RF Telnet Access parameter is set to “Disabled” for every AP in the cluster. In addition, since users situated below the AP are able to pass Telnet sessions up through the SM and AP to the upstream network (while AP RF Telnet Access is set to “Disabled”), ensure that all CMM4 or other networking equipment is secured with strong passwords. Otherwise, users may Telnet to the CMM4 or other networking equipment, and subsequently access network APs (see [Figure 141](#)) via their Ethernet interfaces (since RF Telnet Access only prevents Telnet sessions originating from the AP’s wireless interface).

Figure 141 RF Telnet Access Restriction (orange) and Potential Security Hole (green)

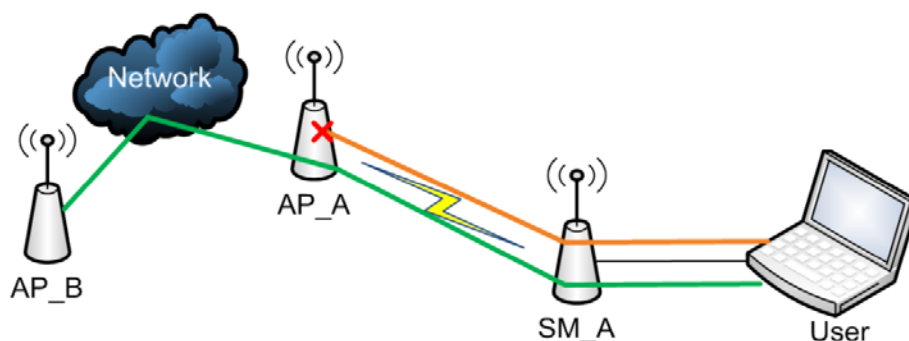

As a common practice, AP administrator usernames and passwords must be secured with strong, non-default passwords.

Restricting AP RF Telnet Access

AP Telnet access via the RF interface may be configured in two ways – the AP GUI and SNMP.

Controlling RF Telnet Access via the AP GUI

To restrict all Telnet access to the AP via the RF interface from downstream devices, follow these instructions using the AP GUI:

Procedure 20 Restricting RF Telnet access

- 1 Log into the AP GUI using administrator credentials
- 2 On the AP GUI, navigate to **Configuration > Protocol Filtering**

- 3 Under GUI heading “Telnet Access over RF Interface”, set **RF Telnet Access** to **Disabled**

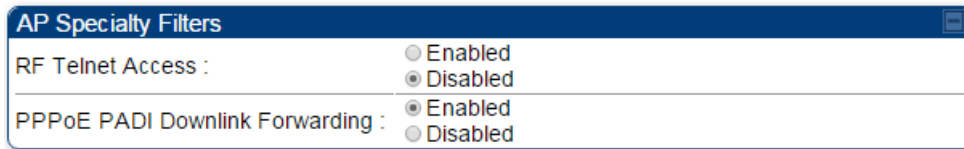

AP Specialty Filters	
RF Telnet Access :	<input type="radio"/> Enabled <input checked="" type="radio"/> Disabled
PPPoE PADI Downlink Forwarding :	<input checked="" type="radio"/> Enabled <input type="radio"/> Disabled

- 4 Click the **Save** button
- 5 Once the **Save** button is clicked, all RF Telnet Access to the AP from devices situated below the AP is blocked.

**Note**

The factory default setting for RF Telnet Access is disabled and PPPoE PADI Downlink Forwarding is enabled.

Configuring SNMP Access

The SNMPv3 interface provides a more secure method to perform SNMP operations. This standard provides services for authentication, data integrity and message encryption over SNMP. Refer to [Planning for SNMPv3 operation](#) on page 3-43 for details.



Note

The factory default setting for SNMP is “SNMPv2c Only”.

Procedure 21 Configuring SNMPv3

- 1 Log into the AP GUI using administrator credentials
- 2 On the AP/SM GUI, navigate to **Configuration > Security Page**
- 3 Under GUI heading “Security Mode”, set **SNMP** to **SNMPv3 Only**

- 4 Click the **Save Changes** button
- 5 Go to **Configuration > SNMP Page**
- 6 Under GUI heading “SNMPv3 setting”, set **Engine ID**, **SNMPv3 Security Level**, **SNMPv3 Authentication Protocol**, **SNMPv3 Privacy Protocol**, **SNMPv3 Read-Only User**, **SNMPv3 Read/Write User**, **SNMPv3 Trap Configuration** parameters:

Engine ID :

Each radio (AP/SM/BHM/BHS) has a distinct SNMP authoritative engine identified by a unique Engine ID. While the Engine ID is configurable to the operator it is expected that the operator follow the guidelines of the SNMPEngineID defined in the SNMP-FRAMEWORK-MIB (RFC 3411). The default Engine ID is the MAC address of the device.

SNMPv3 security level, Authentication and Privacy Protocol

The authentication allows authentication of SNMPv3 user and privacy allows for encryption of SNMPv3 message. 450 Platform Family supports MD5 authentication and CBC-DES privacy protocols.

SNMPv3 Read-Only and Read/Write User

The user can be defined by configurable attributes. The attributes and default values are:

- Read-only user
 - Username = Canopyro
 - Authentication Password = authCanopyro
 - Privacy Password = privacyCanopyro
- Read-write user (by default read-write user is disabled)
 - Username = Canopy
 - Authentication Password = authCanopy
 - Privacy Password = privacyCanopy

SNMPv3 Trap Configuration

The traps may be sent from radios in SNMPv3 format based on parameter settings. It can be configured for Disabled, Enabled for Read-Only User, Enable for Read/Write User.

Configuring Security

Applicable products

PMP : AP SM PTP: BHM BMS

Security page – 450 Platform Family AP/BHM

The security page of AP/BHM is explained in [Table 138](#).

Table 138 Security attributes –450 Platform Family AP

Authentication Server Settings	
Authentication Mode :	Disabled
Authentication Server DNS Usage :	<input type="radio"/> Append DNS Domain Name <input checked="" type="radio"/> Disable DNS Domain Name
Authentication Server 1 :	<input type="text" value="0.0.0.0"/> Shared Secret <input type="text" value="0.0.0.0"/>
Authentication Server 2 :	<input type="text" value="0.0.0.0"/> Shared Secret <input type="text" value="0.0.0.0"/>
Authentication Server 3 :	<input type="text" value="0.0.0.0"/> Shared Secret <input type="text" value="0.0.0.0"/>
Authentication Server 4 (BAM ONLY) :	<input type="text" value="0.0.0.0"/>
Authentication Server 5 (BAM ONLY) :	<input type="text" value="0.0.0.0"/>
Radius Port :	1812 <i>Default port number is 1812</i>
Authentication Key :	<input type="text"/> (Using All 0xFF's Key)
Select Key :	<input type="radio"/> Use Key above <input checked="" type="radio"/> Use Default Key
Dynamic Authorization Extensions for RADIUS :	<input type="radio"/> Enable CoA and Disconnect Message <input checked="" type="radio"/> Disable CoA and Disconnect Message
Bypass Authentication for ICC SMs :	<input type="radio"/> Enabled <input checked="" type="radio"/> Disabled
Airlink Security	
Encryption Setting :	None
AP Evaluation Configuration	
SM Display of AP Evaluation Data :	<input type="radio"/> Disable Display <input checked="" type="radio"/> Enable Display
Session Timeout	
Web, Telnet, FTP Session Timeout :	600 Seconds
IP Access Filtering	
IP Access Control :	<input type="radio"/> IP Access Filtering Enabled - Only allow access from IP addresses specified below <input checked="" type="radio"/> IP Access Filtering Disabled - Allow access from all IP addresses
Allowed Source IP 1 :	<input type="text" value="0.0.0.0"/> / <input type="text" value="32"/> Network Mask (set to 32 to disable)
Allowed Source IP 2 :	<input type="text" value="0.0.0.0"/> / <input type="text" value="32"/> Network Mask (set to 32 to disable)
Allowed Source IP 3 :	<input type="text" value="0.0.0.0"/> / <input type="text" value="32"/> Network Mask (set to 32 to disable)
Security Mode	
Web Access :	HTTP Only
SNMP :	SNMPv2c Only
Telnet :	<input checked="" type="radio"/> Enabled <input type="radio"/> Disabled
FTP :	<input checked="" type="radio"/> Enabled <input type="radio"/> Disabled
TFTP :	<input checked="" type="radio"/> Enabled <input type="radio"/> Disabled





Site Information	
Site Information	<input type="radio"/> Enabled
Viewable to Guest Users :	<input checked="" type="radio"/> Disabled
Site Name :	No Site Name
Site Contact :	No Site Contact
Site Location :	No Site Location

Security Banner	
Enable Security	<input type="radio"/> Enabled
Banner during Login :	<input checked="" type="radio"/> Disabled
Security Banner Notice :	This is a sample of the text that can be put in this banner
User must accept security banner before login :	<input type="radio"/> Enabled <input type="radio"/> Disabled

Attribute	Meaning
Authentication Mode	<p>Operators may use this field to select from among the following authentication modes:</p> <p>Disabled—the AP/BHM requires no SMs/BHS to authenticate. (Factory default).</p> <p>Authentication Server —the AP/BHM requires any SM/BHS that attempts registration to be authenticated in Wireless Manager before registration.</p> <p>AP PreShared Key - The AP/BHM acts as the authentication server to its SMs/BHS and will make use of a user-configurable pre-shared authentication key. The operator enters this key on both the AP/BHM and all SMs/BHS desired to register to that AP/BHM. There is also an option of leaving the AP/BHM and SMs/BHS at their default setting of using the “Default Key”. Due to the nature of the authentication operation, if you want to set a specific authentication key, then you MUST configure the key on all of the SMs/BHS and reboot them BEFORE enabling the key and option on the AP/BHM. Otherwise, if you configure the AP/BHM first, none of the SMs/BHS is able to register.</p> <p>RADIUS AAA - When RADIUS AAA is selected, up to 3 Authentication Server (RADIUS Server) IP addresses and Shared Secrets can be configured. The IP address(s) configured here must match the IP address(s) of the RADIUS server(s). The shared secret(s) configured here must match the shared secret(s) configured in the RADIUS server(s). Servers 2 and 3 are meant for backup and reliability, not for splitting the database. If Server 1 doesn't respond, Server 2 is tried, and then server 3. If Server 1 rejects authentication, the SM is denied entry to the network, and does not progress trying the other servers.</p>

**Note**

This parameter is applicable to BHM.

Authentication Server DNS Usage	<p>The management DNS domain name may be toggled such that the name of the authentication server only needs to be specified and the DNS domain name is automatically appended to that name.</p>
	<p> Note This parameter is applicable to BHM.</p>
Authentication Server 1 to 5	<p>Enter the IP address or server name of the authentication server (RADIUS or WM) and the Shared Secret configured in the authentication server. When Authentication Mode RADIUS AAA is selected, the default value of Shared Secret is “CanopySharedSecret”. The Shared Secret may consist of up to 32 ASCII characters.</p>
	<p> Note This parameter is applicable to BHM.</p>
Radius Port	<p>This field allows the operator to configure a custom port for RADIUS server communication. The default value is 1812.</p>
	<p> Note This parameter is applicable to BHM.</p>
Authentication Key	<p>The authentication key is a 32-character hexadecimal string used when Authentication Mode is set to AP PreShared Key. By default, this key is set to 0xFF.</p>
	<p> Note This parameter is applicable to BHM.</p>
Select Key	<p>This option allows operators to choose which authentication key is used: Use Key above means that the key specified in Authentication Key is used for authentication Use Default Key means that a default key (based off of the SM’s MAC address) is used for authentication</p>
	<p> Note This parameter is applicable to BHM.</p>
Dynamic Authorization Extensions for RADIUS	<p>Enable CoA and Disconnect Message: Allows to control configuration parameters of SM using RADIUS CoA and Disconnect Message feature. Disable CoA and Disconnect Message: Disables RADIUS CoA and Disconnect Message feature. To enable CoA and Disconnect feature, the Authentication Mode should be set to RADIUS AAA.</p>
Bypass Authentication for ICC SMs	<p>Enabled: SM authentication is disabled when SM connects via ICC (Installation Color Code). Disabled: SM authentication is enabled.</p>
Encryption Setting	<p>Specify the type of airlink security to apply to this AP. The encryption setting must match the encryption setting of the SMs.</p>

None provides no encryption on the air link.

DES (Data Encryption Standard): An over-the-air link encryption option that uses secret 56-bit keys and 8 parity bits. DES performs a series of bit permutations, substitutions, and recombination operations on blocks of data. DES encryption does not affect the performance or throughput of the system.

AES (Advanced Encryption Standard): An over-the-air link encryption option that uses the Rijndael algorithm and 128-bit keys to establish a higher level of security than DES. AES products are certified as compliant with the Federal Information Processing Standards (FIPS 197) in the U.S.A.



Note

This parameter is applicable to BHM.

SM Display of AP
Evaluation Data

Or

BHS Display of BHM
Evaluation Data

Allows operators to suppress the display of data about this AP/BHM on the AP/BHM Evaluation tab of the Tools page in all SMs/BHS that register. The factory default setting for SM Display of AP Evaluation Data or BHS Display of BHM Evaluation Data is enabled display.

PMP 450/450i Series – SM display of AP Evaluation Data parameter

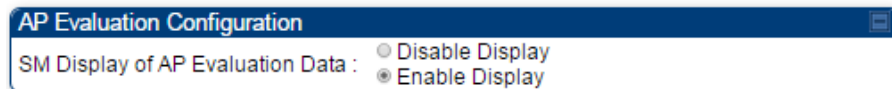

PTP 450/450i Series – BHS display of BHM Evaluation Data parameter

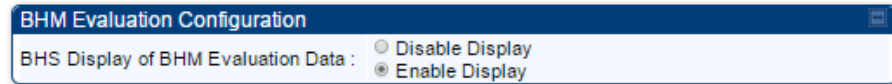

Web, Telnet, FTP
Session Timeout

Enter the expiry in seconds for remote management sessions via **HTTP**, **telnet**, or **ftp** access to the AP/BHM.

IP Access Control

You can permit access to the AP/BHM from any IP address (**IP Access Filtering Disabled**) or limit it to access from only one, two, or three IP addresses that you specify (**IP Access Filtering Enabled**). If you select **IP Access Filtering Enabled**, then you must populate at least one of the three **Allowed Source IP** parameters or have no access permitted from any IP address

Allowed Source IP 1
to 3

If you selected **IP Access Filtering Enabled** for the **IP Access Control** parameter, then you must populate at least one of the three **Allowed Source IP** parameters or have no access permitted to the AP from any IP address. You may populate as many as all three.

If you selected **IP Access Filtering Disabled** for the **IP Access Control** parameter, then no entries in this parameter are read, and access from all IP addresses is permitted.

Web Access

The Radio supports secured and non-secured web access protocols. Select suitable web access from drop down list:

	<ul style="list-style-type: none"> • HTTP Only – provides non-secured web access. The radio to be accessed via http://<IP of Radio>. • HTTPS Only – provides a secured web access. The radio to be accessed via https://<IP of Radio>. • HTTP and HTTPS – If enabled, the radio can be accessed via both http and https.
SNMP	<p>This option allows to configure SNMP agent communication version. It can be selected from drop down list :</p> <ul style="list-style-type: none"> • SNMPv2c Only – Enables SNMP v2 community protocol. • SNMPv3 Only – Enables SNMP v3 protocol. It is a secured communication protocol. • SNMPv2c and SNMPv3 – It enables both the protocols.
Telnet	This option allows to Enable and Disable Telnet access to the Radio.
FTP	This option allows to Enable and Disable FTP access to the Radio.
TFTP	This option allows to Enable and Disable TFTP access to the Radio.

Security page - 450 Platform Family SM

The security page of 450 Platform Family SM is explained in [Table 139](#).

Table 139 Security attributes –450 Platform Family SM

Authentication Key Settings	
Authentication Key :	<input type="text" value="(Using All 0xFF's Key)"/>
Select Key :	<input type="radio"/> Use Key above <input checked="" type="radio"/> Use Default Key

AAA Authentication Settings	
Enforce Authentication :	Disable ▼
Phase 1 :	eapTls ▼
Phase 2 :	MSCHAPv2 ▼
Identity/Realm :	<input type="radio"/> Enable Realm <input checked="" type="radio"/> Disable Realm Identity <input type="text" value="anonymous"/> @ Realm <input type="text" value="canopy.net"/>
Username :	<input type="text" value="0a-00-3e-a0-00-79"/> <input type="button" value="Use Default Username"/>
Password :	<input type="password" value="*****"/>
Confirm Password :	<input type="password"/>

RADIUS Certificate Settings	
Upload Certificate File	
File:	<input type="button" value="Choose File"/> No file chosen
<input type="button" value="Import Certificate"/> <input type="button" value="Use Default Certificates"/> <i>This will delete all current certificates</i>	

Certificate 1	
C =US S =Illinois O = Solutions, Inc. OU =Canopy Wireless Broadband CN =Canopy AAA Server Demo CA E =technical-support@canopywireless.com Valid From: 01/01/2001 00:00:00 Valid To: 12/31/2049 23:59:59 <input type="button" value="Delete"/>	

Certificate 2	
C =US S =Illinois O = Inc. OU =Canopy Wireless Broadband CN =PMP320 Demo CA Valid From: 07/01/2009 06:00:00 Valid To: 12/31/2049 23:59:59 <input type="button" value="Delete"/>	

Airlink Security	
Encryption Setting :	DES ▼
Session Timeout	
Web, Telnet, FTP Session Timeout :	800000 Seconds
SM Management Interface Access via Ethernet Port	
Ethernet Access :	<input checked="" type="radio"/> Enabled <input type="radio"/> Disabled
IP Access Filtering	
IP Access Control :	<input type="radio"/> IP Access Filtering Enabled - Only allow access from IP addresses specified below <input checked="" type="radio"/> IP Access Filtering Disabled - Allow access from all IP addresses
Allowed Source IP 1 :	0.0.0.0 / 32 Network Mask (set to 32 to disable)
Allowed Source IP 2 :	0.0.0.0 / 32 Network Mask (set to 32 to disable)
Allowed Source IP 3 :	0.0.0.0 / 32 Network Mask (set to 32 to disable)
Security Mode	
Web Access :	HTTP Only ▼
SNMP :	SNMPv2c Only ▼
Telnet :	<input checked="" type="radio"/> Enabled <input type="radio"/> Disabled
FTP :	<input checked="" type="radio"/> Enabled <input type="radio"/> Disabled
TFTP :	<input checked="" type="radio"/> Enabled <input type="radio"/> Disabled

Attribute	Meaning
Authentication Key	Only if the AP to which this SM will register requires authentication, specify the key that the SM will use when authenticating. For alpha characters in this hex key, use only upper case.
Select Key	The Use Default Key selection specifies the predetermined key for authentication in Wireless Manager The Use Key above selection specifies the 32-digit hexadecimal key that is permanently stored on both the SM and the WM
Enforce Authentication	The SM may enforce authentication types of AAA and AP Pre-sharedKey . The SM will not finish the registration process if the AP is not using the configured authentication method (and the SM locks out the AP for 15 minutes).
Phase 1	The protocols supported for the Phase 1 (Outside Identity) phase of authentication are EAPTTLS (Extensible Authentication Protocol Tunneled Transport Layer Security) or MSCHAPv2 (Microsoft Challenge-Handshake Authentication Protocol version 2).

Phase 2	<p>Select the desired Phase 2 (Inside Identity) authentication protocol from the Phase 2 options of PAP (Password Authentication Protocol), CHAP (Challenge Handshake Authentication Protocol), and MSCHAP (Microsoft's version of CHAP, version 2 is used). The protocol must be consistent with the authentication protocol configured on the RADIUS server.</p>
Identity/Realm	<p>If Realms are being used, select Enable Realm and configure an outer identity in the Identity field and a Realm in the Realm field. These must match the Phase 1/Outer Identity and Realm configured in the RADIUS server. The default Identity is "anonymous". The Identity can be up to 128 non-special (no diacritical markings) alphanumeric characters. The default Realm is "canopy.net". The Realm can also be up to 128 non-special alphanumeric characters.</p> <p>Configure an outer Identity in the Username field. This must match the Phase 1/Outer Identity username configured in the RADIUS server. The default Phase 1/Outer Identity Username is "anonymous". The Username can be up to 128 non-special (no diacritical markings) alphanumeric characters.</p>
Username	<p>Enter a Username for the SM. This must match the username configured for the SM on the RADIUS server. The default Username is the SM's MAC address. The Username can be up to 128 non-special (no diacritical markings) alphanumeric characters.</p>
Password	<p>Enter the desired password for the SM in the Password and Confirm Password fields. The Password must match the password configured for the SM on the RADIUS server. The default Password is "password". The Password can be up to 128 non-special (no diacritical markings) alphanumeric characters</p>
Upload Certificate File	<p>To upload a certificate manually to a SM, first load it in a known place on your PC or network drive, then click on a Delete button on one of the Certificate description blocks to delete a certificate to provide space for your certificate. Click on Choose File, browse to the location of the certificate, and click the Import Certificate button, and then reboot the radio to use the new certificate.</p> <p>When a certificate is in use, after the SM successfully registers to an AP, an indication of In Use will appear in the description block of the certificate being used.</p> <p>The public certificates installed on the SMs are used with the private certificate on the RADIUS server to provide a public/private key encryption system.</p> <p>Up to 2 certificates can be resident on a SM. An installed certificate can be deleted by clicking the Delete button in the certificate's description block on the Configuration > Security tab. To restore the 2 default certificates, click the Use Default Certificates button in the RADIUS Certificate Settings parameter block and reboot the radio.</p>

Encryption Setting	<p>Specify the type of airlink security to apply to this SM. The encryption setting must match the encryption setting of the AP.</p> <p>None provides no encryption on the air link.</p> <p>DES (Data Encryption Standard): An over-the-air link encryption option that uses secret 56-bit keys and 8 parity bits. DES performs a series of bit permutations, substitutions, and recombination operations on blocks of data. DES encryption does not affect the performance or throughput of the system.</p> <p>AES (Advanced Encryption Standard): An over-the-air link encryption option that uses the Rijndael algorithm and 128-bit keys to establish a higher level of security than DES. AES products are certified as compliant with the Federal Information Processing Standards (FIPS 197) in the U.S.A.</p>
Web, Telnet, FTP Session Timeout	<p>Enter the expiry in seconds for remote management sessions via HTTP, telnet, or FTP access to the SM.</p>
Ethernet Access	<p>If you want to prevent any device that is connected to the Ethernet port of the SM from accessing the management interface of the SM, select Ethernet Access Disabled. This selection disables access through this port to via HTTP (the GUI), SNMP, telnet, FTP, and TFTP. With this selection, management access is available through only the RF interface via either an IP address (if Network Accessibility is set to Public on the SM) or the Session Status or Remote Subscribers tab of the AP.</p>
	<p>Note</p> <p>This setting does not prevent a device connected to the Ethernet port from accessing the management interface of other SMs in the network. To prevent this, use the IP Access Filtering Enabled selection in the IP Access Control parameter of the SMs in the network. See IP Access Control below.</p>
	<p>If you want to allow management access through the Ethernet port, select Ethernet Access Enabled. This is the factory default setting for this parameter.</p>
IP Access Control	<p>You can permit access to the SM from any IP address (IP Access Filtering Disabled) or limit it to access from only one, two, or three IP addresses that you specify (IP Access Filtering Enabled). If you select IP Access Filtering Enabled, then you must populate at least one of the three Allowed Source IP parameters or have no access permitted from any IP address</p>
Allowed Source IP 1 to 3	<p>If you selected IP Access Filtering Enabled for the IP Access Control parameter, then you must populate at least one of the three Allowed Source IP parameters or have no access permitted to the SM from any IP address. You may populate as many as all three.</p> <p>If you selected IP Access Filtering Disabled for the IP Access Control parameter, then no entries in this parameter are read, and access from all IP addresses is permitted.</p> <p>A subnet mask may be defined for each entry to allow for filtering control based on a range of IP addresses.</p>

Web Access	<p>The Radio supports secured and non-secured web access protocols. Select suitable web access from drop down list:</p> <ul style="list-style-type: none"> • HTTP Only – provides non-secured web access. The radio to be accessed via http://<IP of Radio>. • HTTPS Only – provides a secured web access. The radio to be accessed via https://<IP of Radio>. • HTTP and HTTPS – If enabled, the radio can be accessed via both http and https.
SNMP	<p>This option allows to configure SNMP agent communication version. It can be selected from drop down list :</p> <ul style="list-style-type: none"> • SNMPv2c Only – Enables SNMP v2 community protocol. • SNMPv3 Only – Enables SNMP v3 protocol. It is secured communication protocol. • SNMPv2c and SNMPv3 – It enables both the protocols.
Telnet	This option allows to Enable and Disable Telnet access to the Radio.
FTP	This option allows to Enable and Disable FTP access to the Radio.
TFTP	This option allows to Enable and Disable TFTP access to the Radio.
Site Name	Specify a string to associate with the physical module.
Site Contact	Enter contact information for the module administrator.
Site Location	Enter information about the physical location of the module.
Enable Security Banner during Login	<p>Enable: The Security Banner Notice will be displayed before login.</p> <p>Disable: The Security Banner Notice will not be displayed before login.</p>
Security Banner Notice	User can enter ASCII (0-9a-zA-Z newline, line-feed are allowed) text up-to 1300 characters.
User must accept security banner before login	<p>Enable: login area (username and password) will be disabled unless user accepts the security banner.</p> <p>Disable: User can't login to radio without accepting security banner.</p>

Security page –450 Platform Family BHS

The Security page of 450 Platform Family BHS is explained in [Table 140](#).

Table 140 Security attributes - 450 Platform Family BHS

Authentication Key Settings			
Authentication Key :	<input type="text"/>	(Using All 0xFF's Key)	
Airlink Security			
Encryption Setting :	DES ▼		
Session Timeout			
Web, Telnet, FTP Session Timeout :	<input type="text" value="600"/>	Seconds	
IP Access Filtering			
IP Access Control :	<input type="radio"/> IP Access Filtering Enabled - Only allow access from IP addresses specified below <input checked="" type="radio"/> IP Access Filtering Disabled - Allow access from all IP addresses		
Allowed Source IP 1 :	<input type="text" value="0.0.0.0"/>	<input type="text" value="/ 32"/>	Network Mask (set to 32 to disable)
Allowed Source IP 2 :	<input type="text" value="0.0.0.0"/>	<input type="text" value="/ 32"/>	Network Mask (set to 32 to disable)
Allowed Source IP 3 :	<input type="text" value="0.0.0.0"/>	<input type="text" value="/ 32"/>	Network Mask (set to 32 to disable)
Security Mode			
Web Access :	HTTP Only ▼		
SNMP :	SNMPv2c Only ▼		
Telnet :	<input checked="" type="radio"/> Enabled <input type="radio"/> Disabled		
FTP :	<input checked="" type="radio"/> Enabled <input type="radio"/> Disabled		
TFTP :	<input checked="" type="radio"/> Enabled <input type="radio"/> Disabled		

Attribute	Meaning
Authentication Key	Only if the BHM to which this BHS registers requires an authentication, specify the key that the BHS will use when authenticating. For alpha characters in this hex key, use only upper case.
Encryption Setting	<p>Specify the type of airlink security to apply to this BHS. The encryption setting must match the encryption setting of the BHM.</p> <p>None provides no encryption on the air link.</p> <p>DES (Data Encryption Standard): An over-the-air link encryption option that uses secret 56-bit keys and 8 parity bits. DES performs a series of bit permutations, substitutions, and recombination operations on blocks of data. DES encryption does not affect the performance or throughput of the system. It is factory default setting.</p> <p>AES (Advanced Encryption Standard): An over-the-air link encryption option that uses the Rijndael algorithm and 128-bit keys to establish a higher level of security than DES. AES products are certified as compliant with the Federal Information Processing Standards (FIPS 197) in the U.S.A.</p>

Web, Telnet, FTP Session Timeout	Enter the expiry in seconds for remote management sessions via HTTP, telnet, or FTP access to the BHS.
IP Access Control	You can permit access to the BHS from any IP address (IP Access Filtering Disabled) or limit it to access from only one, two, or three IP addresses that you specify (IP Access Filtering Enabled). If you select IP Access Filtering Enabled , then you must populate at least one of the three Allowed Source IP parameters or have no access permitted from any IP address
Allowed Source IP 1 to 3	<p>If you selected IP Access Filtering Enabled for the IP Access Control parameter, then you must populate at least one of the three Allowed Source IP parameters or have no access permitted to the BHS from any IP address. You may populate as many as all three.</p> <p>If you selected IP Access Filtering Disabled for the IP Access Control parameter, then no entries in this parameter are read, and access from all IP addresses is permitted.</p> <p>A subnet mask may be defined for each entry to allow for filtering control based on a range of IP addresses.</p>
Web Access	<p>The Radio supports secured and non-secured web access protocols. Select suitable web access from drop down list:</p> <ul style="list-style-type: none"> • HTTP Only – provides non-secured web access. The radio to be accessed via http://<IP of Radio>. • HTTPS Only – provides a secured web access. The radio to be accessed via https://<IP of Radio>. • HTTP and HTTPS – If enabled, the radio can be accessed via both http and https.
SNMP	<p>This option allows to configure SNMP agent communication version. It can be selected from drop down list :</p> <ul style="list-style-type: none"> • SNMPv2c Only – Enables SNMP v2 community protocol. • SNMPv3 Only – Enables SNMP v3 protocol. It is secured communication protocol. • SNMPv2c and SNMPv3 – It enables both the protocols.
Telnet	This option allows to Enable and Disable Telnet access to the Radio.
FTP	This option allows to Enable and Disable FTP access to the Radio.
TFTP	This option allows to Enable and Disable TFTP access to the Radio.

Configuring radio parameters

- [PMP 450m Series – configuring radio on page 7-127](#)
- [PMP/PTP 450i Series – configuring radio on page 7-127](#)
- [PMP 450b Series - configuring radio on page 7-151](#)
- [PMP/PTP 450 Series – configuring radio on page 7-155](#)
- [Custom Frequencies page on page 7-172](#)
- [DFS for 5 GHz Radios on page 7-175](#)
- [MIMO-A mode of operation on page 7-177](#)
- [Improved PPS performance of 450 Platform Family on page 7-179](#)

PMP 450m Series – configuring radio

Radio page - PMP 450m AP 5 GHz

The **Radio** tab of the PMP 450m AP contains some of the configurable parameters that define how an AP operates.



Note

Only the frequencies available for your region and the selected Channel bandwidth are displayed.

Table 141 PMP 450m AP Radio attributes - 5 GHz

Radio Configuration	
Frequency Band :	5.4 GHz ▾
Frequency Carrier :	5520.0 ▾
Channel Bandwidth :	20 MHz ▾
Cyclic Prefix :	One Sixteenth
Color Code :	250 (0—254)
Subscriber Color Code Rescan (When not on a Primary Color Code) :	0 Minutes (0 — 43200)
Subscriber Color Code Wait Period for Idle :	0 Minutes (0 — 60)
Installation Color Code :	<input type="radio"/> Enabled <input checked="" type="radio"/> Disabled

Frame Configuration	
Max Range :	2 Miles (Range: 1 — 40 miles)
Downlink Data :	85 % (Range: 15 — 85 %)
Contention Slots :	2 (Range: 1 — 15)

Power Control	
EIRP :	22 dBm (Range: +22 — +37 dBm)
SM Receive Target Level :	-60 dBm (Range : -77 — -37 dBm) combined power

Advanced	
Receive Quality Debug :	<input type="radio"/> Enabled <input checked="" type="radio"/> Disabled
Near Field Operation :	<input type="radio"/> Enabled <input checked="" type="radio"/> Disabled

Attribute	Meaning
Frequency Band	Select the desired operating frequency band.
Frequency Carrier	Specify the frequency for the module to transmit. The default for this parameter is None . For a list of channels in the band, see the drop-down list on the radio GUI.
Channel Bandwidth	The channel size used by the radio for RF transmission. The setting for the channel bandwidth must match between the AP and the SM. The supported Channel Bandwidths are 5MHz, 10 MHz, 15 MHz, 20 MHz, and 40 MHz.
Cyclic Prefix	OFDM technology uses a cyclic prefix, where a portion of the end of a symbol (slot) is repeated at the beginning of the symbol to allow multi-pathing to settle before receiving the desired data. A 1/16 cyclic prefix means that for every 16 bits of throughput data transmitted, an additional bit is used.
Color Code	<p>Specify a value from 0 to 254. For registration to occur, the color code of the SM and the AP <i>must</i> match. Color code is not a security feature. Instead, color code is a management feature, typically for assigning each sector a different color code.</p> <p>Color code allows you to force a SM to register to only a specific AP, even where the SM can communicate with multiple APs. The default setting for the color code value is 0. This value matches only the color code of 0 (<i>not</i> all 255 color codes).</p>
Subscriber Color Code Rescan (When not on a Primary Color Code)	<p>This timer may be utilized to initiate SM rescans in order to register to an AP configured with the SM's primary color code.</p> <p>The time (in minutes) for a subscriber to rescan (if this AP is not configured with the SM's primary color code). This timer will only fire once – if the Subscriber Color Code Wait Period for Idle timer is configured with a nonzero value and the Subscriber Color Code Rescan expires, the Subscriber Color Code Wait Period for Idle is started. If the Subscriber Color Code Wait Period for Idle timer is configured with a zero value and the Subscriber Color Code Rescan timer expires, the SM will immediately go into rescan mode</p>
Subscriber Color Code Wait Period for Idle	The time (in minutes) for a subscriber to rescan while idle (if this AP is not configured with the SM's primary color code). This timer will fire periodic events. The fired event determines if any RF unicast traffic (either inbound or outbound) has occurred since the last event. If the results of the event determine that no RF unicast traffic has occurred (SM is idle), then the subscriber will rescan.

Installation Color Code	<p>With this feature enabled on the AP and SM, operators may install and remotely configure SMs without having to configure matching color codes between the modules. While the SM is accessible for configuration from above the AP (for remote provisioning) and below the SM (for local site provisioning), no user data is passed over the radio link. When using the Installation Color Code feature, ensure that the SM is configured with the factory default Color Code configuration (Color Code 1 is “0”, Color Code 2-10 set to “0” and “Disable”). The status of the Installation Color Code can be viewed on the AP Eval web GUI page, and when the SM is registered using the Installation Color Code the message “SM is registered via ICC – Bridging Disabled!” is displayed in red on every SM GUI page. The Installation Color Code parameter is configurable without a radio reboot for both the AP and SM. If a SM is registered via Installation Color Code and the feature is then disabled, operators will need to reboot the SM or force it to reregister (i.e. using Rescan APs functionality on the AP Eval page).</p>
Max Range	<p>Enter a number of miles (or kilometers divided by 1.61, then rounded to an integer) for the furthest distance from which a SM is allowed to register to this AP. Do not set the distance to any greater number of miles. A greater distance</p> <ul style="list-style-type: none"> • does not increase the power of transmission from the AP. • can reduce aggregate throughput. <p>For example, with a 20 MHz channel and 2.5 ms frame, every additional 2.24 miles reduces the data air time by one symbol (around 1% of the frame). Regardless of this distance, the SM must meet the minimum requirements for an acceptable link. The parameters have to be selected so that there is no overlap between one AP transmitting and another AP receiving. A co-location tool is provided to help with selecting sets of parameters that allow co-location.</p> <p>The default value of this parameter is 2 miles (3.2 km).</p>
Downlink Data	<p>Specify the percentage of the aggregate throughput for the downlink (frames transmitted from the AP to the subscriber). For example, if the aggregate (uplink and downlink total) throughput on the AP is 90 Mb, then 75% specified for this parameter allocates 67.5 Mb for the downlink and 22.5 Mb for the uplink. The default for this parameter is 75%. This parameter must be set in the range of 15% - 85%, otherwise the invalid input will not be accepted and the previously-entered valid setting is used.</p>
<div style="display: flex; align-items: flex-start;"> <div style="margin-right: 10px;">  </div> <div> <p>Note</p> <p>In order to prevent self-interference, the frame configuration needs to align which includes Downlink Data, Max Range and Contention slots. For DFS regions, the maximum Downlink % for a 5.4 GHz radio is 75% only.</p> </div> </div>	
Contention Slots (a.k.a. Control Slots)	<p>This field indicates the number of (reserved) Contention slots configured by the operator. The SM uses reserved Contention slots and unused data slots for bandwidth requests. See Contention slots on page 7-176.</p>

EIRP	This field indicates the combined power level at which the AP will transmit, based on the Country Code. It also includes the antenna gain and array gain.
SM Receive Target Level	Each SM's Transmitter Output Power is automatically set by the AP. The AP monitors the received power from each SM, and adjusts each SM's Transmitter Output Power so that the received power at the AP from that SM is not greater what is set in this field. This value represents the transmitted and received power (combined power) perceived on the SM.
Receive Quality Debug	To aid in link performance monitoring, the AP and SM now report the number of fragments received per modulation (i.e. QPSK, 16-QAM, 64-QAM and 256-QAM) and per channel (polarization).
	<div data-bbox="501 689 598 772" data-label="Image"> </div> <p>Note Due to CPU load, this will slightly degrade packet per second processing.</p>
Near Field Operation	<p>This parameter is enabled by the Near Field Operation control. This is only available when the EIRP is set to 22 dBm or below.</p> <p>When Near Field Operation is enabled, the Near Field Range is used to apply compensation to the unit's calibration to support operation in the near field.</p>

PMP/PTP 450i Series – configuring radio

Radio page - PMP 450i AP 3 GHz

The **Radio** tab of the PMP 450i AP 3 GHz is shown in [Figure 142](#).

Figure 142 PMP 450i AP Radio attributes - 3 GHz

Radio Configuration

Frequency Band :	3.5 GHz ▾
Frequency Carrier :	3505.000 ▾
Channel Bandwidth :	10 MHz ▾
Cyclic Prefix :	One Sixteenth ▾
Frame Period :	<input type="radio"/> 5.0 ms <input checked="" type="radio"/> 2.5 ms
Color Code :	43 (0—254)
Subscriber Color Code Rescan (When not on a Primary Color Code) :	0 Minutes (0 — 43200)
Subscriber Color Code Wait Period for Idle :	0 Minutes (0 — 60)
Installation Color Code :	<input type="radio"/> Enabled <input checked="" type="radio"/> Disabled

Frame Configuration

Max Range :	40 Miles (Range: 1 — 40 miles)
Downlink Data :	75 % (Range: 15 — 85 %)
Contention Slots :	3 (Range: 1 — 15)
Broadcast Repeat Count :	2 (Range : 0 — 2)

Power Control

Transmit Power :	15 dBm (Range: -30 — +25 dBm) (12 dBm B / 12 dBm A)
External Gain :	0 dBi (Range: 0 — +70 dBi)
SM Receive Target Level :	-52 dBm (Range : -77 — -37 dBm) combined power
Adjacent Channel Support :	<input type="radio"/> Enabled <input checked="" type="radio"/> Disabled

Multicast Data Control

Multicast VC :	Disable ▾
Multicast Repeat Count :	0 (Range : 0 — 2)
Multicast Downlink CIR :	0 (kbps) (Range: 0— 6093 kbps)

Advanced

MIMO Rate Adapt Algorithm :	MIMO-A/B ▾
Control Messages :	<input type="radio"/> SISO <input checked="" type="radio"/> MIMO-A
Receive Quality Debug :	<input type="radio"/> Enabled <input checked="" type="radio"/> Disabled
	OFF ▾
Frame Alignment Legacy Mode :	Choose Legacy Mode setting from the table below based on collocated radio's software revision and sync source:

Sync Src.\ SW Rev.	13.4.1 or higher	12.0 to 13.4 (DFS on)	12.0 to 13.4 (DFS off)	below 12.0
Timing Port	OFF	OFF	OFF	OFF
Power Port	OFF	OFF	ON (Mode 1)	OFF

**Note**

Refer Table 143 PMP 450i SM Radio attributes – 5 GHz on page 7-138 for parameter details

Radio page - PMP 450i AP 5 GHz

The **Radio** tab of the PMP 450i AP contains some of the configurable parameters that define how an AP operates.

**Note**

Only the frequencies available for your region and the selected Channel bandwidth are displayed.

Table 142 PMP 450i AP Radio attributes - 5 GHz

Radio Configuration	
Frequency Band :	5.4 GHz ▾
Frequency Carrier :	5480.0 ▾
Channel Bandwidth :	10 MHz ▾
Frame Period :	<input type="radio"/> 5.0 ms <input checked="" type="radio"/> 2.5 ms
Cyclic Prefix :	One Sixteenth
Color Code :	0 (0—254)
Subscriber Color Code Rescan (When not on a Primary Color Code) :	0 Minutes (0 — 43200)
Subscriber Color Code Wait Period for Idle :	0 Minutes (0 — 60)
Installation Color Code :	<input type="radio"/> Enabled <input checked="" type="radio"/> Disabled

Frame Configuration	
Max Range :	2 Miles (Range: 1 — 40 miles)
Downlink Data :	75 % (Range: 15 — 85 %)
Contention Slots :	3 (Range: 1 — 15)
Broadcast Repeat Count :	2 (Range : 0 — 2)

Power Control	
Transmit Power :	0 dBm (Range: -30 — +27 dBm) (-3 dBm V / -3 dBm H)
External Gain :	11 dBi (Range: 0 — +40 dBi)
SM Receive Target Level :	-52 dBm (Range : -77 — -37 dBm) combined power



Multicast Data Control	
Multicast VC :	Disable ▾
Multicast Repeat Count :	0 (Range : 0 — 2)
Multicast Downlink CIR :	0 (kbps) (Range: 0— 6093 kbps)

Advanced

SM Registration :	<input checked="" type="radio"/> All (450i/450/430) <input type="radio"/> 450i Only															
PMP 430 SM Registration :	<input checked="" type="radio"/> Allow <input type="radio"/> Deny															
PMP 450/430 Legacy Mode :	<input type="radio"/> Enabled <input checked="" type="radio"/> Disabled															
Control Messages :	<input type="radio"/> SISO <input checked="" type="radio"/> MIMO-A															
PMP 430 Interop Mode :	<input type="radio"/> SISO <input checked="" type="radio"/> MIMO-A															
Receive Quality Debug :	<input type="radio"/> Enabled <input checked="" type="radio"/> Disabled															
	<div style="border: 1px solid black; padding: 2px; width: fit-content;">OFF ▾</div> <p style="font-size: small; margin-top: 10px;">Choose Legacy Mode setting from the table below based on collocated radio's software revision and sync source:</p> <table border="1" style="width: 100%; border-collapse: collapse; font-size: x-small;"> <thead> <tr> <th style="width: 15%;">Sync Src.\ SW Rev.</th> <th style="width: 15%;">13.4.1 or higher</th> <th style="width: 15%;">12.0 to 13.4 (DFS on)</th> <th style="width: 15%;">12.0 to 13.4 (DFS off)</th> <th style="width: 15%;">below 12.0</th> </tr> </thead> <tbody> <tr> <td>Timing Port</td> <td>OFF</td> <td>OFF</td> <td>OFF</td> <td>OFF</td> </tr> <tr> <td>Power Port</td> <td>OFF</td> <td>OFF</td> <td>ON (Mode 1)</td> <td>OFF</td> </tr> </tbody> </table>	Sync Src.\ SW Rev.	13.4.1 or higher	12.0 to 13.4 (DFS on)	12.0 to 13.4 (DFS off)	below 12.0	Timing Port	OFF	OFF	OFF	OFF	Power Port	OFF	OFF	ON (Mode 1)	OFF
Sync Src.\ SW Rev.	13.4.1 or higher	12.0 to 13.4 (DFS on)	12.0 to 13.4 (DFS off)	below 12.0												
Timing Port	OFF	OFF	OFF	OFF												
Power Port	OFF	OFF	ON (Mode 1)	OFF												
Frame Alignment Legacy Mode :																

Attribute	Meaning
Frequency Band	See Table 141 PMP 450m AP Radio attributes - 5 GHz on page 7-127
Frequency Carrier	
Alternate Frequency Carrier 1 and 2	These parameters are displayed based on Regional Settings. Refer Country on page 7-70
Channel Bandwidth	
Cyclic Prefix	
Frame Period	
Color Code	
Subscriber Color Code Rescan (When not on a Primary Color Code)	See Table 141 PMP 450m AP Radio attributes - 5 GHz on page 7-127
Subscriber Color Code Wait Period for Idle	
Installation Color Code	
Max Range	
Downlink Data	See Table 141 PMP 450m AP Radio attributes - 5 GHz on page 7-127

Contention Slots (a.k.a. Control Slots)	This field indicates the number of (reserved) Contention slots configured by the operator. The SM uses reserved Contention slots and unused data slots for bandwidth requests. See Contention slots on page 7-176.
Broadcast Repeat Count	<p>The default is 2 repeats (in addition to the original broadcast packet, for a total of 3 packets sent for every one needed), and is settable to 1 or 0 repeats (2 or 1 packets for every broadcast).</p> <p>ARQ (Automatic Repeat reQuest) is not present in downlink broadcast packets, since it can cause unnecessary uplink traffic from every SM for each broadcast packet. For successful transport without ARQ, the AP repeats downlink broadcast packets. The SMs filter out all repeated broadcast packets and, thus, do not transport further.</p> <p>The default of 2 repeats is optimum for typical uses of the network as an internet access system. In applications with heavy download broadcast such as video distribution, overall throughput is significantly improved by setting the repeat count to 1 or 0. This avoids flooding the downlink with repeat broadcast packets.</p>
Transmitter Output Power	<p>This value represents the combined power of the AP's two transmitters. Nations and regions may regulate transmitter output power. For example</p> <ul style="list-style-type: none"> 900 MHz, 5.4 GHz and 5.8 GHz modules are available as connectorized radios, which require the operator to adjust power to ensure regulatory compliance. <p>The professional installer of the equipment has the responsibility to</p> <ul style="list-style-type: none"> maintain awareness of applicable regulations. calculate the permissible transmitter output power for the module. confirm that the initial power setting is compliant with national or regional regulations. confirm that the power setting is compliant following any reset of the module to factory defaults.
External Gain	This value needs to correspond to the published gain of the antenna used to ensure the radio will meet regulatory requirements.
SM Receive Target Level	See Table 141 PMP 450m AP Radio attributes - 5 GHz on page 7-127
Multicast VC Data Rate	This pull down menu of the Multicast Data Control screen helps in configuring multicast packets to be transmitted over a dedicated channel at a configurable rate of 1X, 2X, 4X or 6X. The default value is "Disable". If set to the default value, all multicast packets are transmitted over the Broadcast VC data path. This feature is available only for the PMP 450 Series and is not backward compatible with PMP 430 series of radios.

Multicast Repeat Count	<p>This value is the number of packets that are repeated for every multicast VC packet received on the AP (located under Radio tab of Configuration). Multicast (like Broadcast) packets go over a VC that is shared by all SMs, so there is no guaranteed delivery. The repeat count is an attempt to improve the odds of the packets getting over the link. If the user has issues with packets getting dropped, they can use this parameter to improve the performance at the cost of the overall throughput possible on that channel. The default value is 0.</p>						
Multicast Downlink CIR	<p>This value is the committed information rate for the multicast downlink VC (located under the Radio tab of Configuration). The default value is 0 kbps. The range of this parameter is based on the number of repeat counts. The higher the repeat count, the lower the range for the multicast downlink CIR.</p>						
SM Registration All	<p>This field allows to control registration of all type 450 Platform Family SM including 430 Series SM(450i/450/430) or 450i Series SM only.</p>						
PMP 430 SM Registration	<p>This field allows to control of PMP 430 SMs whether PMP 430 SMs are allowed to register to PMP 450i APs. By default, it is enabled and PMP 430 SM registrations are accepted.</p> <p>When this field is set to disabled, PMP 430 SM's registrations fail with reject reason 8. This will cause SMs to lock out the AP for 15 minutes.</p>						
	<p> Note This option is not displayed if the Frame Period is set to 5 ms. This option applies only to PMP 450/450i Series APs - 5 GHz.</p>						
Control Message	<p>Controls whether the control messages are sent in MIMO-B or MIMO-A mode. MIMO-A is recommended. However, if an AP on 13.2 is attempting to connect to an SM on 13.1.3 or before, changing to MIMO-B may aid in getting the SM registered.</p>						
PMP 450/430 Legacy mode	<p>Disabled: It is factory default setting. It allows to operate in 450i Series capabilities.</p> <p>Enabled: It allows to operate radio in Legacy mode PMP 450 or 430.</p>						
PMP 430 Interop Mode	<p>For n-1 compatibility, In SISO mode this forces the AP to only send Control and Beacons over one of the RF paths.</p>						
Receive Quality Debug	<p>To aid in link performance monitoring, the AP and SM now report the number of fragments received per modulation (i.e. QPSK, 16-QAM, 64-QAM) and per channel (polarization).</p>						
	<p> Note Due to CPU load, this will slightly degrade packet per second processing.</p>						
Frame Alignment Legacy Mode	<table border="1"> <thead> <tr> <th>Mode</th> <th>Behavior (non-900 MHz radios)</th> <th>Behavior (FSK 900 MHz radios)</th> </tr> </thead> <tbody> <tr> <td></td> <td></td> <td></td> </tr> </tbody> </table>	Mode	Behavior (non-900 MHz radios)	Behavior (FSK 900 MHz radios)			
Mode	Behavior (non-900 MHz radios)	Behavior (FSK 900 MHz radios)					

	By default frame start is aligned with devices with Timing Port synchronization	By default frame start is aligned with FSK 900 MHz devices with Timing Port synchronization
OFF	If the synchronization source changes (due to Autosync or otherwise) the radio will dynamically adjust its frame start to maintain alignment with the default frame start timing	If the synchronization source changes (due to Autosync or otherwise) the radio will dynamically adjust its frame start to maintain alignment with the default frame start timing
ON (Mode 1)	The radio will align with devices running software versions from 12.0 to 13.4.	The radio will align with FSK 900 MHz devices running software versions from 12.0 to 13.4.
ON (Mode 2)	N/A	The radio will align with FSK 900 MHz devices with software versions 11.2 or older.

Radio page - PMP 450i SM 3 GHz

The **Radio** tab of the PMP 450i SM 3 GHz is shown in [Figure 143](#).

Figure 143 PMP 450i SM Radio attributes - 3 GHz

Radio Configuration

3.5/3.6 GHz

<input type="checkbox"/> 3302.500	<input type="checkbox"/> 3303.500	<input type="checkbox"/> 3305.000	<input type="checkbox"/> 3315.000
<input type="checkbox"/> 3325.000	<input type="checkbox"/> 3335.000	<input type="checkbox"/> 3345.000	<input type="checkbox"/> 3355.000
<input type="checkbox"/> 3365.000	<input type="checkbox"/> 3375.000	<input type="checkbox"/> 3385.000	<input type="checkbox"/> 3395.000
<input type="checkbox"/> 3405.000	<input type="checkbox"/> 3415.000	<input type="checkbox"/> 3425.000	<input type="checkbox"/> 3435.000
<input type="checkbox"/> 3445.000	<input type="checkbox"/> 3455.000	<input type="checkbox"/> 3465.000	<input type="checkbox"/> 3475.000
<input type="checkbox"/> 3485.000	<input type="checkbox"/> 3495.000	<input type="checkbox"/> 3500.000	<input checked="" type="checkbox"/> 3505.000
<input type="checkbox"/> 3515.000	<input type="checkbox"/> 3525.000	<input type="checkbox"/> 3535.000	<input type="checkbox"/> 3545.000
<input type="checkbox"/> 3552.500	<input type="checkbox"/> 3555.000	<input type="checkbox"/> 3565.000	<input type="checkbox"/> 3575.000
<input type="checkbox"/> 3585.000	<input type="checkbox"/> 3595.000	<input type="checkbox"/> 3600.000	<input type="checkbox"/> 3652.500
<input type="checkbox"/> 3675.000	<input type="checkbox"/> 3690.000	<input type="checkbox"/> 3847.500	

Custom Radio Frequency Scan Selection List :

5 MHz only
 <= 7 MHz
 <= 10 MHz
 <= 15 MHz
 <= 20 MHz

Not available in this region

Channel Bandwidth Scan :

5 MHz
 7 MHz
 10 MHz
 15 MHz
 20 MHz
 30 MHz

Cyclic Prefix Scan : One Sixteenth

AP Selection Method :

Power Level
 Optimize for Throughput

Color Code 1 : (0—254) / Priority

Installation Color Code : Enabled
 Disabled

Large VC data Q : Enabled
 Disabled

Additional Color Codes

Color Code : (0—254) / Priority

Additional Color Codes Table

No additional color codes configured

Power Control

External Gain : dBi (Range: 0 — +70 dBi)

Advanced

Receive Quality Debug : Enabled
 Disabled



Note

Refer Table 143 PMP 450i SM Radio attributes – 5 GHz on page 7-138 for parameter details

Radio page – PMP 450i SM 5 GHz

The **Radio** page of PMP 450i SM is explained in [Table 143](#).

Table 143 PMP 450i SM Radio attributes – 5 GHz

Radio Configuration

4.9 GHz

<input type="checkbox"/> 4905.000	<input type="checkbox"/> 4907.500	<input type="checkbox"/> 4910.000	<input type="checkbox"/> 4912.500	<input type="checkbox"/> 4915.000
<input type="checkbox"/> 4917.500	<input type="checkbox"/> 4920.000	<input type="checkbox"/> 4922.500	<input type="checkbox"/> 4925.000	<input type="checkbox"/> 4927.500
<input type="checkbox"/> 4930.000	<input type="checkbox"/> 4932.500	<input type="checkbox"/> 4935.000	<input type="checkbox"/> 4937.500	<input type="checkbox"/> 4940.000
<input checked="" type="checkbox"/> 4942.500	<input checked="" type="checkbox"/> 4945.000	<input checked="" type="checkbox"/> 4947.500	<input checked="" type="checkbox"/> 4950.000	<input checked="" type="checkbox"/> 4952.500
<input checked="" type="checkbox"/> 4955.000	<input checked="" type="checkbox"/> 4957.500	<input type="checkbox"/> 4960.000	<input type="checkbox"/> 4962.500	<input type="checkbox"/> 4965.000
<input type="checkbox"/> 4967.500	<input type="checkbox"/> 4970.000	<input checked="" type="checkbox"/> 4972.500	<input checked="" type="checkbox"/> 4975.000	<input checked="" type="checkbox"/> 4977.500
<input checked="" type="checkbox"/> 4980.000	<input checked="" type="checkbox"/> 4982.500	<input checked="" type="checkbox"/> 4985.000	<input checked="" type="checkbox"/> 4987.500	<input checked="" type="checkbox"/> 4990.000
<input type="checkbox"/> 4992.500	<input type="checkbox"/> 4995.000			

5.1 GHz

<input type="checkbox"/> 5152.5	<input type="checkbox"/> 5155.0	<input checked="" type="checkbox"/> 5157.5	<input checked="" type="checkbox"/> 5160.0	<input checked="" type="checkbox"/> 5162.5	<input checked="" type="checkbox"/> 5165.0	<input checked="" type="checkbox"/> 5167.5
<input checked="" type="checkbox"/> 5170.0	<input checked="" type="checkbox"/> 5172.5	<input checked="" type="checkbox"/> 5175.0	<input checked="" type="checkbox"/> 5177.5	<input checked="" type="checkbox"/> 5180.0	<input type="checkbox"/> 5182.5	<input type="checkbox"/> 5185.0
<input type="checkbox"/> 5187.5	<input type="checkbox"/> 5190.0	<input type="checkbox"/> 5192.5	<input type="checkbox"/> 5195.0	<input type="checkbox"/> 5197.5	<input type="checkbox"/> 5200.0	<input type="checkbox"/> 5202.5
<input type="checkbox"/> 5205.0	<input type="checkbox"/> 5207.5	<input type="checkbox"/> 5210.0	<input type="checkbox"/> 5212.5	<input type="checkbox"/> 5215.0	<input type="checkbox"/> 5217.5	<input type="checkbox"/> 5220.0
<input type="checkbox"/> 5222.5	<input type="checkbox"/> 5225.0	<input type="checkbox"/> 5227.5	<input type="checkbox"/> 5230.0	<input type="checkbox"/> 5232.5	<input type="checkbox"/> 5235.0	<input checked="" type="checkbox"/> 5237.5
<input checked="" type="checkbox"/> 5240.0	<input checked="" type="checkbox"/> 5242.5	<input checked="" type="checkbox"/> 5245.0	<input checked="" type="checkbox"/> 5247.5			

5.4 GHz

<input type="checkbox"/> 5472.5	<input checked="" type="checkbox"/> 5475.0	<input checked="" type="checkbox"/> 5477.5	<input checked="" type="checkbox"/> 5480.0	<input checked="" type="checkbox"/> 5482.5	<input checked="" type="checkbox"/> 5485.0	<input checked="" type="checkbox"/> 5487.5
<input type="checkbox"/> 5490.0	<input type="checkbox"/> 5492.5	<input type="checkbox"/> 5495.0	<input type="checkbox"/> 5497.5	<input type="checkbox"/> 5500.0	<input type="checkbox"/> 5502.5	<input type="checkbox"/> 5505.0
<input type="checkbox"/> 5507.5	<input type="checkbox"/> 5510.0	<input type="checkbox"/> 5512.5	<input type="checkbox"/> 5515.0	<input type="checkbox"/> 5517.5	<input type="checkbox"/> 5520.0	<input type="checkbox"/> 5522.5
<input type="checkbox"/> 5525.0	<input type="checkbox"/> 5527.5	<input type="checkbox"/> 5530.0	<input type="checkbox"/> 5532.5	<input type="checkbox"/> 5535.0	<input type="checkbox"/> 5537.5	<input type="checkbox"/> 5540.0
<input type="checkbox"/> 5542.5	<input type="checkbox"/> 5545.0	<input type="checkbox"/> 5547.5	<input type="checkbox"/> 5550.0	<input type="checkbox"/> 5552.5	<input type="checkbox"/> 5555.0	<input type="checkbox"/> 5557.5
<input type="checkbox"/> 5560.0	<input type="checkbox"/> 5562.5	<input type="checkbox"/> 5565.0	<input type="checkbox"/> 5567.5	<input type="checkbox"/> 5570.0	<input type="checkbox"/> 5572.5	<input type="checkbox"/> 5575.0
<input type="checkbox"/> 5577.5	<input type="checkbox"/> 5580.0	<input type="checkbox"/> 5582.5	<input type="checkbox"/> 5585.0	<input type="checkbox"/> 5587.5	<input type="checkbox"/> 5590.0	<input type="checkbox"/> 5592.5
<input type="checkbox"/> 5595.0	<input type="checkbox"/> 5597.5	<input checked="" type="checkbox"/> 5600.0	<input checked="" type="checkbox"/> 5602.5	<input checked="" type="checkbox"/> 5605.0	<input checked="" type="checkbox"/> 5607.5	<input checked="" type="checkbox"/> 5610.0
<input checked="" type="checkbox"/> 5612.5	<input checked="" type="checkbox"/> 5615.0	<input checked="" type="checkbox"/> 5617.5	<input checked="" type="checkbox"/> 5620.0	<input checked="" type="checkbox"/> 5622.5	<input checked="" type="checkbox"/> 5625.0	<input checked="" type="checkbox"/> 5627.5
<input checked="" type="checkbox"/> 5630.0	<input checked="" type="checkbox"/> 5632.5	<input checked="" type="checkbox"/> 5635.0	<input checked="" type="checkbox"/> 5637.5	<input checked="" type="checkbox"/> 5640.0	<input checked="" type="checkbox"/> 5642.5	<input checked="" type="checkbox"/> 5645.0
<input checked="" type="checkbox"/> 5647.5	<input checked="" type="checkbox"/> 5650.0	<input type="checkbox"/> 5652.5	<input type="checkbox"/> 5655.0	<input type="checkbox"/> 5657.5	<input type="checkbox"/> 5660.0	<input type="checkbox"/> 5662.5
<input type="checkbox"/> 5665.0	<input type="checkbox"/> 5667.5	<input type="checkbox"/> 5670.0	<input type="checkbox"/> 5672.5	<input type="checkbox"/> 5675.0	<input type="checkbox"/> 5677.5	<input type="checkbox"/> 5680.0
<input type="checkbox"/> 5682.5	<input type="checkbox"/> 5685.0	<input type="checkbox"/> 5687.5	<input checked="" type="checkbox"/> 5690.0	<input type="checkbox"/> 5692.5	<input type="checkbox"/> 5695.0	<input type="checkbox"/> 5697.5
<input type="checkbox"/> 5700.0	<input type="checkbox"/> 5702.5	<input type="checkbox"/> 5705.0	<input checked="" type="checkbox"/> 5707.5	<input checked="" type="checkbox"/> 5710.0	<input checked="" type="checkbox"/> 5712.5	<input checked="" type="checkbox"/> 5715.0
<input checked="" type="checkbox"/> 5717.5	<input checked="" type="checkbox"/> 5720.0	<input type="checkbox"/> 5722.5				

Custom Radio Frequency Scan Selection List :

5.7 GHz

<input type="checkbox"/> 5727.5	<input type="checkbox"/> 5730.0	<input type="checkbox"/> 5732.5	<input type="checkbox"/> 5735.0	<input type="checkbox"/> 5737.5	<input type="checkbox"/> 5740.0	<input type="checkbox"/> 5742.5
<input type="checkbox"/> 5745.0	<input type="checkbox"/> 5747.5	<input type="checkbox"/> 5750.0	<input type="checkbox"/> 5752.5	<input checked="" type="checkbox"/> 5755.0	<input type="checkbox"/> 5757.5	<input type="checkbox"/> 5760.0
<input type="checkbox"/> 5762.5	<input type="checkbox"/> 5765.0	<input type="checkbox"/> 5767.5	<input type="checkbox"/> 5770.0	<input type="checkbox"/> 5772.5	<input type="checkbox"/> 5775.0	<input type="checkbox"/> 5777.5
<input type="checkbox"/> 5780.0	<input type="checkbox"/> 5782.5	<input type="checkbox"/> 5785.0	<input type="checkbox"/> 5787.5	<input type="checkbox"/> 5790.0	<input type="checkbox"/> 5792.5	<input type="checkbox"/> 5795.0
<input type="checkbox"/> 5797.5	<input type="checkbox"/> 5800.0	<input type="checkbox"/> 5802.5	<input type="checkbox"/> 5805.0	<input type="checkbox"/> 5807.5	<input type="checkbox"/> 5810.0	<input type="checkbox"/> 5812.5
<input type="checkbox"/> 5815.0	<input type="checkbox"/> 5817.5	<input type="checkbox"/> 5820.0	<input type="checkbox"/> 5822.5	<input type="checkbox"/> 5825.0	<input type="checkbox"/> 5827.5	<input type="checkbox"/> 5830.0
<input type="checkbox"/> 5832.5	<input type="checkbox"/> 5835.0	<input type="checkbox"/> 5837.5	<input type="checkbox"/> 5840.0	<input type="checkbox"/> 5842.5	<input type="checkbox"/> 5845.0	<input type="checkbox"/> 5847.5
<input type="checkbox"/> 5850.0	<input type="checkbox"/> 5852.5	<input type="checkbox"/> 5855.0	<input type="checkbox"/> 5857.5	<input type="checkbox"/> 5860.0	<input type="checkbox"/> 5862.5	<input type="checkbox"/> 5865.0
<input type="checkbox"/> 5867.5	<input type="checkbox"/> 5870.0	<input type="checkbox"/> 5872.5	<input type="checkbox"/> 5875.0	<input type="checkbox"/> 5877.5	<input type="checkbox"/> 5880.0	<input type="checkbox"/> 5882.5
<input type="checkbox"/> 5885.0	<input type="checkbox"/> 5887.5	<input type="checkbox"/> 5890.0	<input type="checkbox"/> 5892.5	<input type="checkbox"/> 5895.0	<input type="checkbox"/> 5897.5	<input type="checkbox"/> 5900.0
<input type="checkbox"/> 5902.5	<input type="checkbox"/> 5905.0	<input type="checkbox"/> 5907.5	<input type="checkbox"/> 5910.0	<input type="checkbox"/> 5912.5	<input type="checkbox"/> 5915.0	<input type="checkbox"/> 5917.5
<input type="checkbox"/> 5920.0	<input type="checkbox"/> 5922.5					

5 MHz only
≤ 10 MHz
≤ 15 MHz
≤ 20 MHz
≤ 30 MHz
FCC TDWR Band
Not available in this region

Channel Bandwidth Scan :

5 MHz

10 MHz

15 MHz

20 MHz

30 MHz

40 MHz

Cyclic Prefix : One Sixteenth

AP Selection Method :

Power Level

Optimize for Throughput

Color Code 1 : 212 (0—254) / Priority Primary

Installation Color Code :

Enabled

Disabled

Large VC data Q :

Enabled

Disabled

Additional Color Codes

Color Code : 0 (0—254) / Priority Primary

Additional Color Codes Table

No additional color codes configured

Power Control



External Gain : 23 dBi (Range: 0 — +40 dBi)

Advanced

Receive Quality Debug :

Enabled

Disabled

Attribute	Meaning
Custom Radio Frequency Scan Selection List	Check the frequencies that SM has to scan for AP transmissions. See Radio Frequency Scan Selection List on page 7-169.
Channel Bandwidth Scan	<p>The channel size used by the radio for RF transmission.</p> <hr/> <div style="display: flex; align-items: center;">  <div style="margin-left: 10px;"> <p>Note</p> <p>Selecting multiple channel bandwidths will increase registration and re-registration times.</p> </div> </div> <hr/>
Cyclic Prefix Scan	The cyclic prefix for which AP scanning is executed.
AP Selection Method	<p>Operators may configure the method by which a scanning SM selects an AP. By default, AP Selection Method is set to “Optimize for Throughput”, which has been the mode of operation in releases prior to 12.0.3.1.</p> <p>Power Level: AP selection based solely on power level</p> <hr/> <div style="display: flex; align-items: center;">  <div style="margin-left: 10px;"> <p>Note</p> <p>For operation with a PMP 450m AP, select the Power Level option</p> </div> </div> <hr/> <p>or</p> <p>Optimize for Throughput: AP selection based on throughput optimization – the selection decision is based on power level (which affects the modulation state), channel bandwidth (which affects throughput) and number of SM registrations to the AP (which affects system contention performance).</p> <hr/>
Color Code 1	<p>Color code allows you to force the SM to register to only a specific AP, even where the SM can communicate with multiple APs. For registration to occur, the color code of the SM and the AP <i>must</i> match. Specify a value from 0 to 254.</p> <p>Color code is not a security feature. Instead, color code is a management feature, typically for assigning each sector a different color code. The default setting for the color code value is 0. This value matches only the color code of 0 (<i>not</i> all 255 color codes).</p> <p>SMs may be configured with up to 20 color codes. These color codes can be tagged as Primary, Secondary, or Tertiary, or Disable. When the SM is scanning for APs, it will first attempt to register to an AP that matches one of the SM’s primary color codes. Failing that, the SM will continue scanning and attempt to register to an AP that matches one of the SM’s secondary color codes. Failing that, the SM will continue scanning and attempt to register to an AP that matches one of the SM’s tertiary color codes. This is all done in the scanning mode of the SM and will repeat until a registration has occurred.</p> <hr/>

Installation Color Code	<p>Color codes in the same priority group are treated equally. For example, all APs matching one of the SM's primary color codes are analyzed equally. Likewise, this evaluation is done for the secondary and tertiary groups in order. The analysis for selecting an AP within a priority group is based on various inputs, including signal strength and number of SMs already registered to each AP.</p> <p>The first color code in the configuration is the pre-Release 9.5 color code. Thus, it is always a primary color code for legacy reasons.</p> <p>The color codes can be disabled, with the exception of the first color code.</p>
External Gain	<p>This value represents the antenna gain.</p> <p>For ODUs with integrated antenna, this is set at the correct value in the factory.</p> <p>For Connectorized ODUs with external antenna, the user must set this value to the overall antenna gain, including any RF cable loss between the ODU and the antenna.</p>
Large VC data Queue	<p>SM and BH have a configurable option used to prevent packet loss in the uplink due to bursting IP traffic. This is designed for IP burst traffic particular to video surveillance applications.</p>
Receive Quality Debug	<p>To aid in link performance monitoring, the AP and SM now report the number of fragments received per modulation (i.e. QPSK, 16-QAM, 64-QAM) and per channel (polarization).</p>
	<div style="display: flex; align-items: flex-start; margin-top: 10px;"> <div style="margin-right: 10px;"></div> <div> <p>Note</p> <p>Due to CPU load, this will slightly degrade packet per second processing.</p> </div> </div>

	<p>Note</p> <p>The frequencies that a user can select are controlled by the country or a region and the Channel Bandwidth selected. There can be a case where a user adds a custom frequency (from the Custom Frequencies page on page 7-172) and cannot see it in the pull down menu.</p>
---	---

Radio page - PMP 450i AP 900 MHz

The Radio tab of the PMP 450i AP 900 MHz is described in below table [Table 144](#).

Table 144 PMP 450i AP Radio attributes - 900 MHz

Radio Configuration	
Frequency Carrier :	917.00 ▼
Channel Bandwidth :	10 MHz ▼
Cyclic Prefix :	One Sixteenth ▼
Frame Period :	<input checked="" type="radio"/> 5.0 ms <input type="radio"/> 2.5 ms
Color Code :	85 (0—254)
Subscriber Color Code Rescan (When not on a Primary Color Code) :	0 Minutes (0 — 43200)
Subscriber Color Code Wait Period for Idle :	0 Minutes (0 — 60)
Installation Color Code :	<input type="radio"/> Enabled <input checked="" type="radio"/> Disabled

Frame Configuration	
Max Range :	2 Miles (Range: 1 — 120 miles)
Downlink Data :	50 % (Range: 15 — 85 %)
Contention Slots :	3 (Range: 1 — 15)
Broadcast Repeat Count :	2 (Range: 0 — 2)

Power Control	
Transmit Power :	25 dBm (Range: -30 — +25 dBm) (22 dBm B / 22 dBm A)
External Gain :	0 dB (Range: 0 — +40 dB)
SM Receive Target Level :	-52 dBm (Range : -77 — -37 dBm) combined power

Multicast Data Control	
Multicast VC Data Rate :	Disable ▼
Multicast Repeat Count :	0 (Range : 0 — 2)
Multicast Downlink CIR :	0 (kbps) (Range: 0— 0 kbps)

Advanced													
Control Messages :	<input type="radio"/> SISO <input checked="" type="radio"/> MIMO-A												
Receive Quality Debug :	<input type="radio"/> Enabled <input checked="" type="radio"/> Disabled												
Pager Reject Filter :	<input type="radio"/> Enabled <input checked="" type="radio"/> Disabled (NOTE: Frequencies 920 MHz and above will not work when enabled.)												
	OFF ▼												
Frame Alignment Legacy Mode :	Choose Legacy Mode setting from the table below based on colocated 900 MHz FSK's software revision and sync source: <table border="1"> <thead> <tr> <th>Sync Src.\ SW Rev.</th> <th>13.4.1 or higher</th> <th>12.0 to 13.4</th> <th>below 12.0</th> </tr> </thead> <tbody> <tr> <td>Timing Port</td> <td>OFF</td> <td>OFF</td> <td>OFF</td> </tr> <tr> <td>Power Port</td> <td>OFF</td> <td>ON (Mode 1)</td> <td>ON (Mode 2)</td> </tr> </tbody> </table>	Sync Src.\ SW Rev.	13.4.1 or higher	12.0 to 13.4	below 12.0	Timing Port	OFF	OFF	OFF	Power Port	OFF	ON (Mode 1)	ON (Mode 2)
Sync Src.\ SW Rev.	13.4.1 or higher	12.0 to 13.4	below 12.0										
Timing Port	OFF	OFF	OFF										
Power Port	OFF	ON (Mode 1)	ON (Mode 2)										

Attribute	Meaning
Frequency Carrier	Specify the frequency for the module to transmit. The default for this parameter is None . For a list of channels in the band, see the drop-down list on the radio GUI.
Channel Bandwidth	The channel size used by the radio for RF transmission. The setting for the channel bandwidth must match between the AP and the SM. The supported Channel Bandwidths are 5, 7, 10 and 20 MHz.
Cyclic Prefix	
Frame Period	
Color Code	
Subscriber Color Code Rescan (When not on a Primary Color Code)	See Table 141 PMP 450m AP Radio attributes - 5 GHz on page 7-127.
Subscriber Color Code Wait Period for Idle	
Installation Color Code	
Max Range	
Downlink Data	
Contention Slots (a.k.a. Control Slots)	See Table 141 PMP 450m AP Radio attributes - 5 GHz on page 7-127.
Broadcast Repeat Count	
Transmitter Output Power	See Table 142 PMP 450i AP Radio attributes - 5 GHz on page 7-132.
External Gain	
SM Receive Target Level	
Multicast VC Data Rate	
Multicast Repeat Count	See Table 141 PMP 450m AP Radio attributes - 5 GHz on page 7-127
Multicast Downlink CIR	
Control Message	
Receive Quality Debug	
Pager Reject Filter	In 900 MHz, Pager Reject filter is placed on the AP to block Pager signals which could cause interference to the whole band. The Pager signals typically operate in the 928-930 frequency range. When the filter is enabled, the signals of 920 MHz and above are attenuated which enables better reception of signals in the rest of the band. Note that the AP/SM should not be configured on the frequencies of 920 MHz and above when this filter is enabled.

Frame Alignment Legacy Mode See [Table 142 PMP 450i AP Radio attributes - 5 GHz](#) on page 7-132.

Radio page - PTP 450i BHM 5 GHz

The **Radio** page of PTP 450i BHM is explained in [Table 145](#).

Table 145 PTP 450i BHM Radio page attributes – 5 GHz

Radio Configuration	
Frequency Band :	5.4 GHz ▾
Frequency Carrier :	5490.0 ▾
Channel Bandwidth :	20 MHz ▾
Cyclic Prefix :	One Sixteenth ▾
Frame Period :	<input type="radio"/> 5.0 ms <input checked="" type="radio"/> 2.5 ms
Color Code :	254 (0—254)
Large VC data Q :	<input type="radio"/> Enabled <input checked="" type="radio"/> Disabled

Frame Configuration	
Downlink Data :	75 % (Range: 15 — 85 %)

Power Control	
Transmit Power :	-10 dBm (Range: -30 — +27 dBm) (-13 dBm V / -13 dBm H)
External Gain :	0 dB (Range: 0 — +40 dB)

Advanced																
Receive Quality Debug :	<input type="radio"/> Enabled <input checked="" type="radio"/> Disabled OFF ▾															
Frame Alignment Legacy Mode :	Choose Legacy Mode setting from the table below based on colocated radio's software revision and sync source: <table border="1"> <thead> <tr> <th>Sync Src.\ SW Rev.</th> <th>13.4.1 or higher</th> <th>12.0 to 13.4 (DFS on)</th> <th>12.0 to 13.4 (DFS off)</th> <th>below 12.0</th> </tr> </thead> <tbody> <tr> <td>Timing Port</td> <td>OFF</td> <td>OFF</td> <td>OFF</td> <td>OFF</td> </tr> <tr> <td>Power Port</td> <td>OFF</td> <td>OFF</td> <td>ON (Mode 1)</td> <td>OFF</td> </tr> </tbody> </table>	Sync Src.\ SW Rev.	13.4.1 or higher	12.0 to 13.4 (DFS on)	12.0 to 13.4 (DFS off)	below 12.0	Timing Port	OFF	OFF	OFF	OFF	Power Port	OFF	OFF	ON (Mode 1)	OFF
Sync Src.\ SW Rev.	13.4.1 or higher	12.0 to 13.4 (DFS on)	12.0 to 13.4 (DFS off)	below 12.0												
Timing Port	OFF	OFF	OFF	OFF												
Power Port	OFF	OFF	ON (Mode 1)	OFF												

Attribute	Meaning
Frequency Band	Select the operating frequency band of the radio. The supported bands are 4.9 GHz, 5.4 GHz and 5.7 GHz.
Frequency Carrier	Specify the frequency for the module to transmit. The default for this parameter is None . For a list of channels in the band, see the drop-down list on the radio GUI.
Channel Bandwidth	The channel size used by the radio for RF transmission. The setting for the channel bandwidth must match between the BHM and the BHS.
Cyclic Prefix	OFDM technology uses a cyclic prefix, where a portion of the end of a symbol (slot) is repeated at the beginning of the symbol to allow multi-pathing to settle before receiving the desired data. A 1/16 cyclic prefix means that for every 16 bits of throughput data transmitted, an additional bit is used.
Frame Period	Select the Frame Period of the radio. The support Frame Periods are : 5 ms and 2.5 ms.
Color Code	Specify a value from 0 to 254. For registration to occur, the color code of the BHM and the BHS must match. Color code is not a security feature. Instead, color code is a management feature, typically for assigning each link a different color code. Color code allows you to force a BHS to register to only a specific BHM. The default setting for the color code value is 0. This value matches only the color code of 0 (not all 255 color codes).
Large VC data Q	Enable Large VC Q for applications that burst data high rates. Large Qs may decrease effective throughput for TCP application. Disable Large VC Q if application need not handle bursts of data. Large Qs may decrease effective throughput for TCP application.
Downlink Data	Specify the percentage of the aggregate throughput for the downlink (frames transmitted from the BHM to the subscriber). For example, if the aggregate (uplink and downlink total) throughput on the BHM is 132 Mbps, then 75% specified for this parameter allocates 99 Mbps for the downlink and 33 Mbps for the uplink. The default for this parameter is 50%. This parameter must be set in the range of 15% - 85%, otherwise the invalid input will not be accepted and the previously-entered valid setting is used.
	 Note In order to prevent self-interference, the frame configuration needs to align. This includes Downlink Data, Max Range and Contention slots.
Transmit Power	This value represents the combined power of the BHM's two transmitters. Nations and regions may regulate transmit power. For example <ul style="list-style-type: none"> • PTP 450i Series modules are available as connectorized radios, which require the operator to adjust power to ensure regulatory compliance.

External Gain	<p>The professional installer of the equipment has the responsibility to:</p> <ul style="list-style-type: none"> • Maintain awareness of applicable regulations. • Calculate the permissible transmitter output power for the module. • Confirm that the initial power setting is compliant with national or regional regulations. <p>Confirm that the power setting is compliant following any reset of the module to factory defaults.</p>
Receive Quality Debug	<p>To aid in link performance monitoring, the BHM and BHS now report the number of fragments received per modulation (i.e. QPSK, 16-QAM, 64-QAM and 256-QAM) and per channel (polarization).</p>
<div style="display: flex; align-items: flex-start;"> <div style="margin-right: 10px;">  </div> <div> <p>Note</p> <p>Due to CPU load, this slightly degrades the packet during per second processing.</p> </div> </div>	
Frame Alignment Legacy Mode	<p>See Table 142 PMP 450i AP Radio attributes - 5 GHz on page 7-132.</p>

Radio page – PTP 450i BHS 5 GHz

The Radio page of PTP 450i BHS is explained in [Table 146](#).

Table 146 PTP 450i BHS Radio attributes – 5 GHz

Radio Configuration

4.9 GHz

<input type="checkbox"/> 4905.000	<input type="checkbox"/> 4907.500	<input type="checkbox"/> 4910.000	<input type="checkbox"/> 4912.500	<input type="checkbox"/> 4915.000
<input type="checkbox"/> 4917.500	<input type="checkbox"/> 4920.000	<input type="checkbox"/> 4922.500	<input type="checkbox"/> 4925.000	<input type="checkbox"/> 4927.500
<input type="checkbox"/> 4930.000	<input type="checkbox"/> 4932.500	<input type="checkbox"/> 4935.000	<input type="checkbox"/> 4937.500	<input type="checkbox"/> 4940.000
<input type="checkbox"/> 4942.500	<input type="checkbox"/> 4945.000	<input type="checkbox"/> 4947.500	<input type="checkbox"/> 4950.000	<input type="checkbox"/> 4952.500
<input type="checkbox"/> 4955.000	<input type="checkbox"/> 4957.500	<input type="checkbox"/> 4960.000	<input type="checkbox"/> 4962.500	<input type="checkbox"/> 4965.000
<input type="checkbox"/> 4967.500	<input type="checkbox"/> 4970.000	<input type="checkbox"/> 4972.500	<input type="checkbox"/> 4975.000	<input type="checkbox"/> 4977.500
<input type="checkbox"/> 4980.000	<input type="checkbox"/> 4982.500	<input type="checkbox"/> 4985.000	<input type="checkbox"/> 4987.500	<input type="checkbox"/> 4990.000
<input type="checkbox"/> 4992.500	<input type="checkbox"/> 4995.000			

5.1 GHz

<input type="checkbox"/> 5152.5	<input type="checkbox"/> 5155.0	<input type="checkbox"/> 5157.5	<input type="checkbox"/> 5160.0	<input type="checkbox"/> 5162.5	<input type="checkbox"/> 5165.0	<input type="checkbox"/> 5167.5
<input type="checkbox"/> 5170.0	<input type="checkbox"/> 5172.5	<input type="checkbox"/> 5175.0	<input type="checkbox"/> 5177.5	<input type="checkbox"/> 5180.0	<input type="checkbox"/> 5182.5	<input type="checkbox"/> 5185.0
<input type="checkbox"/> 5187.5	<input type="checkbox"/> 5190.0	<input type="checkbox"/> 5192.5	<input type="checkbox"/> 5195.0	<input type="checkbox"/> 5197.5	<input type="checkbox"/> 5200.0	<input type="checkbox"/> 5202.5
<input type="checkbox"/> 5205.0	<input type="checkbox"/> 5207.5	<input type="checkbox"/> 5210.0	<input type="checkbox"/> 5212.5	<input type="checkbox"/> 5215.0	<input type="checkbox"/> 5217.5	<input type="checkbox"/> 5220.0
<input type="checkbox"/> 5222.5	<input type="checkbox"/> 5225.0	<input type="checkbox"/> 5227.5	<input type="checkbox"/> 5230.0	<input type="checkbox"/> 5232.5	<input type="checkbox"/> 5235.0	<input type="checkbox"/> 5237.5
<input type="checkbox"/> 5240.0	<input type="checkbox"/> 5242.5	<input type="checkbox"/> 5245.0	<input type="checkbox"/> 5247.5			

5.4 GHz

<input type="checkbox"/> 5472.5	<input type="checkbox"/> 5475.0	<input type="checkbox"/> 5477.5	<input type="checkbox"/> 5480.0	<input type="checkbox"/> 5482.5	<input type="checkbox"/> 5485.0	<input type="checkbox"/> 5487.5
<input type="checkbox"/> 5490.0	<input type="checkbox"/> 5492.5	<input type="checkbox"/> 5495.0	<input type="checkbox"/> 5497.5	<input type="checkbox"/> 5500.0	<input type="checkbox"/> 5502.5	<input type="checkbox"/> 5505.0
<input type="checkbox"/> 5507.5	<input type="checkbox"/> 5510.0	<input type="checkbox"/> 5512.5	<input type="checkbox"/> 5515.0	<input type="checkbox"/> 5517.5	<input checked="" type="checkbox"/> 5520.0	<input type="checkbox"/> 5522.5
<input type="checkbox"/> 5525.0	<input type="checkbox"/> 5527.5	<input type="checkbox"/> 5530.0	<input type="checkbox"/> 5532.5	<input type="checkbox"/> 5535.0	<input type="checkbox"/> 5537.5	<input type="checkbox"/> 5540.0
<input type="checkbox"/> 5542.5	<input type="checkbox"/> 5545.0	<input type="checkbox"/> 5547.5	<input type="checkbox"/> 5550.0	<input type="checkbox"/> 5552.5	<input type="checkbox"/> 5555.0	<input type="checkbox"/> 5557.5
<input type="checkbox"/> 5560.0	<input type="checkbox"/> 5562.5	<input type="checkbox"/> 5565.0	<input type="checkbox"/> 5567.5	<input type="checkbox"/> 5570.0	<input type="checkbox"/> 5572.5	<input type="checkbox"/> 5575.0
<input type="checkbox"/> 5577.5	<input type="checkbox"/> 5580.0	<input type="checkbox"/> 5582.5	<input type="checkbox"/> 5585.0	<input type="checkbox"/> 5587.5	<input type="checkbox"/> 5590.0	<input type="checkbox"/> 5592.5
<input type="checkbox"/> 5595.0	<input type="checkbox"/> 5597.5	<input checked="" type="checkbox"/> 5600.0	<input type="checkbox"/> 5602.5	<input type="checkbox"/> 5605.0	<input type="checkbox"/> 5607.5	<input type="checkbox"/> 5610.0
<input type="checkbox"/> 5612.5	<input type="checkbox"/> 5615.0	<input type="checkbox"/> 5617.5	<input type="checkbox"/> 5620.0	<input type="checkbox"/> 5622.5	<input type="checkbox"/> 5625.0	<input type="checkbox"/> 5627.5
<input type="checkbox"/> 5630.0	<input type="checkbox"/> 5632.5	<input type="checkbox"/> 5635.0	<input type="checkbox"/> 5637.5	<input type="checkbox"/> 5640.0	<input type="checkbox"/> 5642.5	<input type="checkbox"/> 5645.0
<input type="checkbox"/> 5647.5	<input type="checkbox"/> 5650.0	<input type="checkbox"/> 5652.5	<input type="checkbox"/> 5655.0	<input type="checkbox"/> 5657.5	<input type="checkbox"/> 5660.0	<input type="checkbox"/> 5662.5
<input type="checkbox"/> 5665.0	<input type="checkbox"/> 5667.5	<input type="checkbox"/> 5670.0	<input type="checkbox"/> 5672.5	<input type="checkbox"/> 5675.0	<input type="checkbox"/> 5677.5	<input type="checkbox"/> 5680.0
<input type="checkbox"/> 5682.5	<input type="checkbox"/> 5685.0	<input type="checkbox"/> 5687.5	<input type="checkbox"/> 5690.0	<input type="checkbox"/> 5692.5	<input type="checkbox"/> 5695.0	<input type="checkbox"/> 5697.5
<input type="checkbox"/> 5700.0	<input type="checkbox"/> 5702.5	<input type="checkbox"/> 5705.0	<input type="checkbox"/> 5707.5	<input type="checkbox"/> 5710.0	<input type="checkbox"/> 5712.5	<input type="checkbox"/> 5715.0
<input type="checkbox"/> 5717.5	<input type="checkbox"/> 5720.0	<input type="checkbox"/> 5722.5				

Custom Radio Frequency Scan Selection List:

5.7 GHz

<input type="checkbox"/> 5727.5	<input type="checkbox"/> 5730.0	<input type="checkbox"/> 5732.5	<input type="checkbox"/> 5735.0	<input type="checkbox"/> 5737.5	<input type="checkbox"/> 5740.0	<input type="checkbox"/> 5742.5
<input type="checkbox"/> 5745.0	<input type="checkbox"/> 5747.5	<input type="checkbox"/> 5750.0	<input type="checkbox"/> 5752.5	<input type="checkbox"/> 5755.0	<input type="checkbox"/> 5757.5	<input type="checkbox"/> 5760.0
<input type="checkbox"/> 5762.5	<input type="checkbox"/> 5765.0	<input type="checkbox"/> 5767.5	<input type="checkbox"/> 5770.0	<input type="checkbox"/> 5772.5	<input type="checkbox"/> 5775.0	<input type="checkbox"/> 5777.5
<input type="checkbox"/> 5780.0	<input type="checkbox"/> 5782.5	<input type="checkbox"/> 5785.0	<input type="checkbox"/> 5787.5	<input type="checkbox"/> 5790.0	<input type="checkbox"/> 5792.5	<input type="checkbox"/> 5795.0
<input type="checkbox"/> 5797.5	<input type="checkbox"/> 5800.0	<input type="checkbox"/> 5802.5	<input type="checkbox"/> 5805.0	<input type="checkbox"/> 5807.5	<input type="checkbox"/> 5810.0	<input type="checkbox"/> 5812.5
<input type="checkbox"/> 5815.0	<input type="checkbox"/> 5817.5	<input type="checkbox"/> 5820.0	<input type="checkbox"/> 5822.5	<input type="checkbox"/> 5825.0	<input type="checkbox"/> 5827.5	<input type="checkbox"/> 5830.0
<input type="checkbox"/> 5832.5	<input type="checkbox"/> 5835.0	<input type="checkbox"/> 5837.5	<input type="checkbox"/> 5840.0	<input type="checkbox"/> 5842.5	<input type="checkbox"/> 5845.0	<input type="checkbox"/> 5847.5
<input type="checkbox"/> 5850.0	<input type="checkbox"/> 5852.5	<input type="checkbox"/> 5855.0	<input type="checkbox"/> 5857.5	<input type="checkbox"/> 5860.0	<input type="checkbox"/> 5862.5	<input type="checkbox"/> 5865.0
<input type="checkbox"/> 5867.5	<input type="checkbox"/> 5870.0	<input type="checkbox"/> 5872.5	<input type="checkbox"/> 5875.0	<input type="checkbox"/> 5877.5	<input type="checkbox"/> 5880.0	<input type="checkbox"/> 5882.5
<input type="checkbox"/> 5885.0	<input type="checkbox"/> 5887.5	<input type="checkbox"/> 5890.0	<input type="checkbox"/> 5892.5	<input type="checkbox"/> 5895.0	<input type="checkbox"/> 5897.5	<input type="checkbox"/> 5900.0
<input type="checkbox"/> 5902.5	<input type="checkbox"/> 5905.0	<input type="checkbox"/> 5907.5	<input type="checkbox"/> 5910.0	<input type="checkbox"/> 5912.5	<input type="checkbox"/> 5915.0	<input type="checkbox"/> 5917.5
<input type="checkbox"/> 5920.0	<input type="checkbox"/> 5922.5					

5 MHz only
≤ 10 MHz
≤ 15 MHz
≤ 20 MHz
≤ 30 MHz
 Not available in this region

Channel Bandwidth Scan :

- 5 MHz
- 10 MHz
- 15 MHz
- 20 MHz
- 30 MHz
- 40 MHz

Cyclic Prefix : One Sixteenth

Color Code : 212 (0—254)

Large VC data Q : Enabled Disabled

Power Control

Transmit Power : 16 dBm (Range: -30 — +27 dBm) (13 dBm V / 13 dBm H)

External Gain : 0 dBi (Range: 0 — +40 dBi)

Advanced

Receive Quality Debug : Enabled Disabled

Attribute	Meaning
Custom Radio Frequency Scan Selection List	Check any frequency that you want the BHS to scan for BHM transmissions. See Radio Frequency Scan Selection List on page 7-169.
Channel Bandwidth Scan	The channel size used by the radio for RF transmission.
	<div style="display: flex; align-items: center;"> <div> <p>Note</p> <p>Selecting multiple channel bandwidths will increase registration and re-registration times.</p> </div> </div>

Page 7-150

Cyclic Prefix Scan	The cyclic prefix for which BHM scanning is executed.
Color Code	Color code allows to force the BHS to register to only a specific BHM, even where the BHS can communicate with multiple BHMs. For registration to occur, the color code of the BHS and the BHM <i>must</i> match. Specify a value from 0 to 254. The color codes can be disabled, with the exception of the first color code.
Large VC data Q	BHM and BHS have a configurable option used to prevent packet loss in the uplink due to bursting IP traffic. This is designed for IP burst traffic particular to video surveillance applications.
Transmit Power	Refer Table 145 PTP 450i BHM Radio page attributes – 5 GHz on page 7-145
External Gain	
Receive Quality	
Debug	

PMP 450b Series - configuring radio

Radio page – PMP 450b SM 5 GHz

The Radio page of PMP 450b SM is explained in [Table 147](#).

Table 147 PMP 450b SM Radio attributes – 5 GHz

Radio Configuration							
4.9 GHz							
No custom frequencies present.							
5.1 GHz							
<input type="checkbox"/>	<input type="checkbox"/>	<input type="checkbox"/>	<input type="checkbox"/>	<input type="checkbox"/>	<input type="checkbox"/>	<input type="checkbox"/>	<input type="checkbox"/>
5152.5	5155.0	5157.5	5160.0	5162.5	5165.0	5167.5	
<input type="checkbox"/>	<input type="checkbox"/>	<input type="checkbox"/>	<input type="checkbox"/>	<input type="checkbox"/>	<input type="checkbox"/>	<input type="checkbox"/>	<input type="checkbox"/>
5170.0	5172.5	5175.0	5177.5	5180.0	5182.5	5185.0	
<input type="checkbox"/>	<input type="checkbox"/>	<input type="checkbox"/>	<input type="checkbox"/>	<input type="checkbox"/>	<input type="checkbox"/>	<input type="checkbox"/>	<input type="checkbox"/>
5187.5	5190.0	5192.5	5195.0	5197.5	5200.0	5202.5	
<input type="checkbox"/>	<input type="checkbox"/>	<input type="checkbox"/>	<input type="checkbox"/>	<input type="checkbox"/>	<input type="checkbox"/>	<input type="checkbox"/>	<input type="checkbox"/>
5205.0	5207.5	5210.0	5212.5	5215.0	5217.5	5220.0	
<input type="checkbox"/>	<input type="checkbox"/>	<input type="checkbox"/>	<input type="checkbox"/>	<input type="checkbox"/>	<input type="checkbox"/>	<input type="checkbox"/>	<input type="checkbox"/>
5222.5	5225.0	5227.5	5230.0	5232.5	5235.0	5237.5	
<input type="checkbox"/>	<input type="checkbox"/>	<input type="checkbox"/>	<input type="checkbox"/>	<input type="checkbox"/>	<input type="checkbox"/>	<input type="checkbox"/>	<input type="checkbox"/>
5240.0	5242.5	5245.0	5247.5				
5.2 GHz							
<input type="checkbox"/>	<input type="checkbox"/>	<input type="checkbox"/>	<input type="checkbox"/>	<input type="checkbox"/>	<input type="checkbox"/>	<input type="checkbox"/>	<input type="checkbox"/>
5252.5	5255.0	5257.5	5260.0	5262.5	5265.0	5267.5	
<input type="checkbox"/>	<input type="checkbox"/>	<input type="checkbox"/>	<input type="checkbox"/>	<input type="checkbox"/>	<input type="checkbox"/>	<input type="checkbox"/>	<input type="checkbox"/>
5270.0	5272.5	5275.0	5277.5	5280.0	5282.5	5285.0	
<input type="checkbox"/>	<input type="checkbox"/>	<input type="checkbox"/>	<input type="checkbox"/>	<input type="checkbox"/>	<input type="checkbox"/>	<input type="checkbox"/>	<input type="checkbox"/>
5287.5	5290.0	5292.5	5295.0	5297.5	5300.0	5302.5	
<input type="checkbox"/>	<input type="checkbox"/>	<input type="checkbox"/>	<input type="checkbox"/>	<input type="checkbox"/>	<input type="checkbox"/>	<input type="checkbox"/>	<input type="checkbox"/>
5305.0	5307.5	5310.0	5312.5	5315.0	5317.5	5320.0	
<input type="checkbox"/>	<input type="checkbox"/>	<input type="checkbox"/>	<input type="checkbox"/>	<input type="checkbox"/>	<input type="checkbox"/>	<input type="checkbox"/>	<input type="checkbox"/>
5322.5	5325.0	5327.5	5330.0	5332.5	5335.0	5337.5	
<input type="checkbox"/>	<input type="checkbox"/>	<input type="checkbox"/>	<input type="checkbox"/>	<input type="checkbox"/>	<input type="checkbox"/>	<input type="checkbox"/>	<input type="checkbox"/>
5340.0	5342.5	5345.0	5347.5				
5.4 GHz							
<input type="checkbox"/>	<input type="checkbox"/>	<input type="checkbox"/>	<input type="checkbox"/>	<input type="checkbox"/>	<input type="checkbox"/>	<input type="checkbox"/>	<input type="checkbox"/>
5472.5	5475.0	5477.5	5480.0	5482.5	5485.0	5487.5	
<input type="checkbox"/>	<input type="checkbox"/>	<input type="checkbox"/>	<input type="checkbox"/>	<input type="checkbox"/>	<input type="checkbox"/>	<input type="checkbox"/>	<input type="checkbox"/>
5490.0	5492.5	5495.0	5497.5	5500.0	5502.5	5505.0	
<input type="checkbox"/>	<input type="checkbox"/>	<input type="checkbox"/>	<input type="checkbox"/>	<input type="checkbox"/>	<input type="checkbox"/>	<input type="checkbox"/>	<input type="checkbox"/>
5507.5	5510.0	5512.5	5515.0	5517.5	5520.0	5522.5	
<input type="checkbox"/>	<input type="checkbox"/>	<input type="checkbox"/>	<input type="checkbox"/>	<input type="checkbox"/>	<input type="checkbox"/>	<input type="checkbox"/>	<input type="checkbox"/>
5525.0	5527.5	5530.0	5532.5	5535.0	5537.5	5540.0	
<input type="checkbox"/>	<input type="checkbox"/>	<input type="checkbox"/>	<input type="checkbox"/>	<input type="checkbox"/>	<input type="checkbox"/>	<input type="checkbox"/>	<input type="checkbox"/>
5542.5	5545.0	5547.5	5550.0	5552.5	5555.0	5557.5	
<input type="checkbox"/>	<input type="checkbox"/>	<input type="checkbox"/>	<input type="checkbox"/>	<input type="checkbox"/>	<input type="checkbox"/>	<input type="checkbox"/>	<input type="checkbox"/>
5560.0	5562.5	5565.0	5567.5	5570.0	5572.5	5575.0	
<input type="checkbox"/>	<input type="checkbox"/>	<input type="checkbox"/>	<input type="checkbox"/>	<input type="checkbox"/>	<input type="checkbox"/>	<input type="checkbox"/>	<input type="checkbox"/>
5577.5	5580.0	5582.5	5585.0	5587.5	5590.0	5592.5	
<input type="checkbox"/>	<input type="checkbox"/>	<input type="checkbox"/>	<input type="checkbox"/>	<input type="checkbox"/>	<input type="checkbox"/>	<input type="checkbox"/>	<input type="checkbox"/>
5595.0	5597.5	5600.0	5602.5	5605.0	5607.5	5610.0	
<input type="checkbox"/>	<input type="checkbox"/>	<input type="checkbox"/>	<input type="checkbox"/>	<input type="checkbox"/>	<input type="checkbox"/>	<input type="checkbox"/>	<input type="checkbox"/>
5612.5	5615.0	5617.5	5620.0	5622.5	5625.0	5627.5	
<input type="checkbox"/>	<input type="checkbox"/>	<input type="checkbox"/>	<input type="checkbox"/>	<input type="checkbox"/>	<input type="checkbox"/>	<input type="checkbox"/>	<input type="checkbox"/>
5630.0	5632.5	5635.0	5637.5	5640.0	5642.5	5645.0	
<input type="checkbox"/>	<input type="checkbox"/>	<input type="checkbox"/>	<input type="checkbox"/>	<input type="checkbox"/>	<input type="checkbox"/>	<input type="checkbox"/>	<input type="checkbox"/>
5647.5	5650.0	5652.5	5655.0	5657.5	5660.0	5662.5	
<input type="checkbox"/>	<input type="checkbox"/>	<input type="checkbox"/>	<input type="checkbox"/>	<input type="checkbox"/>	<input type="checkbox"/>	<input type="checkbox"/>	<input type="checkbox"/>
5665.0	5667.5	5670.0	5672.5	5675.0	5677.5	5680.0	
<input type="checkbox"/>	<input type="checkbox"/>	<input type="checkbox"/>	<input type="checkbox"/>	<input type="checkbox"/>	<input type="checkbox"/>	<input type="checkbox"/>	<input type="checkbox"/>
5682.5	5685.0	5687.5	5690.0	5692.5	5695.0	5697.5	
<input type="checkbox"/>	<input type="checkbox"/>	<input type="checkbox"/>	<input type="checkbox"/>	<input type="checkbox"/>	<input type="checkbox"/>	<input type="checkbox"/>	<input type="checkbox"/>
<input checked="" type="checkbox"/>	<input type="checkbox"/>	<input type="checkbox"/>	<input type="checkbox"/>	<input type="checkbox"/>	<input type="checkbox"/>	<input type="checkbox"/>	<input type="checkbox"/>
5700.0	5702.5	5705.0	5707.5	5710.0	5712.5	5715.0	
<input type="checkbox"/>	<input type="checkbox"/>	<input type="checkbox"/>	<input type="checkbox"/>	<input type="checkbox"/>	<input type="checkbox"/>	<input type="checkbox"/>	<input type="checkbox"/>
5717.5	5720.0	5722.5					

Custom Radio Frequency Scan Selection List :

5.7 GHz

<input type="checkbox"/> 5727.5	<input type="checkbox"/> 5730.0	<input type="checkbox"/> 5732.5	<input type="checkbox"/> 5735.0	<input type="checkbox"/> 5737.5	<input type="checkbox"/> 5740.0	<input type="checkbox"/> 5742.5
<input type="checkbox"/> 5745.0	<input type="checkbox"/> 5747.5	<input type="checkbox"/> 5750.0	<input type="checkbox"/> 5752.5	<input type="checkbox"/> 5755.0	<input type="checkbox"/> 5757.5	<input type="checkbox"/> 5760.0
<input type="checkbox"/> 5762.5	<input type="checkbox"/> 5765.0	<input type="checkbox"/> 5767.5	<input type="checkbox"/> 5770.0	<input type="checkbox"/> 5772.5	<input type="checkbox"/> 5775.0	<input type="checkbox"/> 5777.5
<input type="checkbox"/> 5780.0	<input type="checkbox"/> 5782.5	<input type="checkbox"/> 5785.0	<input type="checkbox"/> 5787.5	<input type="checkbox"/> 5790.0	<input type="checkbox"/> 5792.5	<input type="checkbox"/> 5795.0
<input type="checkbox"/> 5797.5	<input type="checkbox"/> 5800.0	<input type="checkbox"/> 5802.5	<input type="checkbox"/> 5805.0	<input type="checkbox"/> 5807.5	<input type="checkbox"/> 5810.0	<input type="checkbox"/> 5812.5
<input type="checkbox"/> 5815.0	<input type="checkbox"/> 5817.5	<input type="checkbox"/> 5820.0	<input type="checkbox"/> 5822.5	<input type="checkbox"/> 5825.0	<input type="checkbox"/> 5827.5	<input type="checkbox"/> 5830.0
<input type="checkbox"/> 5832.5	<input type="checkbox"/> 5835.0	<input type="checkbox"/> 5837.5	<input type="checkbox"/> 5840.0	<input type="checkbox"/> 5842.5	<input type="checkbox"/> 5845.0	<input type="checkbox"/> 5847.5
<input type="checkbox"/> 5850.0	<input type="checkbox"/> 5852.5	<input type="checkbox"/> 5855.0	<input type="checkbox"/> 5857.5	<input type="checkbox"/> 5860.0	<input type="checkbox"/> 5862.5	<input type="checkbox"/> 5865.0
<input type="checkbox"/> 5867.5	<input type="checkbox"/> 5870.0	<input type="checkbox"/> 5872.5	<input type="checkbox"/> 5875.0	<input type="checkbox"/> 5877.5	<input type="checkbox"/> 5880.0	<input type="checkbox"/> 5882.5
<input type="checkbox"/> 5885.0	<input type="checkbox"/> 5887.5	<input type="checkbox"/> 5890.0	<input type="checkbox"/> 5892.5	<input type="checkbox"/> 5895.0	<input type="checkbox"/> 5897.5	<input type="checkbox"/> 5900.0
<input type="checkbox"/> 5902.5	<input type="checkbox"/> 5905.0	<input type="checkbox"/> 5907.5	<input type="checkbox"/> 5910.0	<input type="checkbox"/> 5912.5	<input type="checkbox"/> 5915.0	<input type="checkbox"/> 5917.5
<input type="checkbox"/> 5920.0	<input type="checkbox"/> 5922.5					

5 MHz only
≤ 10 MHz
≤ 15 MHz
≤ 20 MHz
≤ 30 MHz
Not available in this region

Channel Bandwidth Scan :

5 MHz
 10 MHz
 15 MHz
 20 MHz
 30 MHz
 40 MHz

Cyclic Prefix : One Sixteenth

AP Selection Method :

Power Level
 Optimize for Throughput

Color Code 1 : 182 (0—254) / Priority Primary ▼

Installation Color Code :

Enabled
 Disabled

Large VC data Q :

Enabled
 Disabled

Additional Color Codes

Color Code : 0 (0—254) / Priority Primary ▼

Additional Color Codes Table

No additional color codes configured



Power Control



External Gain : 0 dBi (Range: 0 — +40 dBi)

Advanced

Receive Quality Debug :

Enabled
 Disabled

Attribute	Meaning
Custom Radio Frequency Scan Selection List	Check the frequencies that SM has to scan for AP transmissions. See Radio Frequency Scan Selection List on page 7-169.
Channel Bandwidth Scan	<p>The channel size used by the radio for RF transmission.</p> <hr/> <div style="display: flex; align-items: center;">  <div> <p>Note</p> <p>Selecting multiple channel bandwidths will increase registration and re-registration times.</p> </div> </div>
Cyclic Prefix Scan	The cyclic prefix for which AP scanning is executed.
AP Selection Method	<p>Operators may configure the method by which a scanning SM selects an AP. By default, AP Selection Method is set to “Optimize for Throughput”, which has been the mode of operation in releases prior to 12.0.3.1.</p> <p>Power Level: AP selection based solely on power level</p> <hr/> <div style="display: flex; align-items: center;">  <div> <p>Note</p> <p>For operation with a PMP 450m AP, select the Power Level option</p> </div> </div>
	<p>or</p> <p>Optimize for Throughput: AP selection based on throughput optimization – the selection decision is based on power level (which affects the modulation state), channel bandwidth (which affects throughput) and number of SM registrations to the AP (which affects system contention performance).</p>
Color Code 1	<p>Color code allows you to force the SM to register to only a specific AP, even where the SM can communicate with multiple APs. For registration to occur, the color code of the SM and the AP <i>must</i> match. Specify a value from 0 to 254.</p> <p>Color code is not a security feature. Instead, color code is a management feature, typically for assigning each sector a different color code. The default setting for the color code value is 0. This value matches only the color code of 0 (<i>not</i> all 255 color codes).</p> <p>SMs may be configured with up to 20 color codes. These color codes can be tagged as Primary, Secondary, or Tertiary, or Disable. When the SM is scanning for APs, it will first attempt to register to an AP that matches one of the SM’s primary color codes. Failing that, the SM will continue scanning and attempt to register to an AP that matches one of the SM’s secondary color codes. Failing that, the SM will continue scanning and attempt to register to an AP that matches one of the SM’s tertiary color codes. This is all done in the scanning mode of the SM and will repeat until a registration has occurred.</p>

Installation Color Code	<p>Color codes in the same priority group are treated equally. For example, all APs matching one of the SM's primary color codes are analyzed equally. Likewise, this evaluation is done for the secondary and tertiary groups in order. The analysis for selecting an AP within a priority group is based on various inputs, including signal strength and number of SMs already registered to each AP.</p> <p>The first color code in the configuration is the pre-Release 9.5 color code. Thus, it is always a primary color code for legacy reasons.</p> <p>The color codes can be disabled, with the exception of the first color code.</p>
External Gain	<p>This value represents the antenna gain.</p> <p>For ODUs with integrated antenna, this is set at the correct value in the factory.</p> <p>For Connectorized ODUs with external antenna, the user must set this value to the overall antenna gain, including any RF cable loss between the ODU and the antenna.</p>
Large VC data Queue	<p>SM and BH have a configurable option used to prevent packet loss in the uplink due to bursting IP traffic. This is designed for IP burst traffic particular to video surveillance applications.</p>
Receive Quality Debug	<p>To aid in link performance monitoring, the AP and SM now report the number of fragments received per modulation (i.e. QPSK, 16-QAM, 64-QAM) and per channel (polarization).</p>
	<div style="display: flex; align-items: flex-start; margin-top: 10px;"> <div style="margin-right: 10px;">  </div> <div> <p>Note</p> <p>Due to CPU load, this will slightly degrade packet per second processing.</p> </div> </div>
	<div style="display: flex; align-items: flex-start; margin-top: 10px;"> <div style="margin-right: 10px;">  </div> <div> <p>Note</p> <p>The frequencies that a user can select are controlled by the country or a region and the Channel Bandwidth selected. There can be a case where a user adds a custom frequency (from the Custom Frequencies page on page 7-172) and cannot see it in the pull down menu.</p> </div> </div>

PMP/PTP 450 Series – configuring radio

Radio page - PMP 450 AP 5 GHz

The **Radio** tab of the AP for 5 GHz is as shown in [Table 148](#).

Table 148 PMP 450 AP Radio attributes - 5 GHz

Radio Configuration																
Frequency Band :	5.4 GHz ▾															
Frequency Carrier :	5480.0 ▾															
Channel Bandwidth :	20 MHz ▾															
Cyclic Prefix :	One Sixteenth ▾															
Frame Period :	<input type="radio"/> 5.0 ms <input checked="" type="radio"/> 2.5 ms															
Color Code :	5 (0—254)															
Subscriber Color Code Rescan (When not on a Primary Color Code) :	0 Minutes (0 — 43200)															
Subscriber Color Code Wait Period for Idle :	0 Minutes (0 — 60)															
Installation Color Code :	<input checked="" type="radio"/> Enabled <input type="radio"/> Disabled															
Frame Configuration																
Max Range :	2 Miles (Range: 1 — 40 miles)															
Downlink Data :	75 % (Range: 15 — 85 %)															
Contention Slots :	3 (Range: 1 — 15)															
Broadcast Repeat Count :	2 (Range : 0 — 2)															
Power Control																
Transmit Power :	16 dBm (Range: -30 — +22 dBm) (13 dBm V / 13 dBm H)															
External Gain :	0 dB (Range: 0 — +40 dB)															
SM Receive Target Level :	-52 dBm (Range : -77 — -37 dBm) combined power															
Multicast Data Control																
Multicast VC Data Rate :	Disable ▾															
Multicast Repeat Count :	0 (Range : 0 — 2)															
Multicast Downlink CIR :	0 (kbps) (Range: 0— 0 kbps)															
Advanced																
PMP 430 SM Registration :	<input checked="" type="radio"/> Allow <input type="radio"/> Deny															
Control Messages :	<input type="radio"/> SISO <input checked="" type="radio"/> MIMO-A															
PMP 430 Interop Mode :	<input type="radio"/> SISO <input checked="" type="radio"/> MIMO-A															
Receive Quality Debug :	<input type="radio"/> Enabled <input checked="" type="radio"/> Disabled															
	OFF ▾															
	Choose Legacy Mode setting from the table below based on collocated radio's software revision and sync source:															
Frame Alignment Legacy Mode :	<table border="1"> <thead> <tr> <th>Sync Src.\ SW Rev.</th> <th>13.4.1 or higher</th> <th>12.0 to 13.4 (DFS on)</th> <th>12.0 to 13.4 (DFS off)</th> <th>below 12.0</th> </tr> </thead> <tbody> <tr> <td>Timing Port</td> <td>OFF</td> <td>OFF</td> <td>OFF</td> <td>OFF</td> </tr> <tr> <td>Power Port</td> <td>OFF</td> <td>OFF</td> <td>ON (Mode 1)</td> <td>OFF</td> </tr> </tbody> </table>	Sync Src.\ SW Rev.	13.4.1 or higher	12.0 to 13.4 (DFS on)	12.0 to 13.4 (DFS off)	below 12.0	Timing Port	OFF	OFF	OFF	OFF	Power Port	OFF	OFF	ON (Mode 1)	OFF
Sync Src.\ SW Rev.	13.4.1 or higher	12.0 to 13.4 (DFS on)	12.0 to 13.4 (DFS off)	below 12.0												
Timing Port	OFF	OFF	OFF	OFF												
Power Port	OFF	OFF	ON (Mode 1)	OFF												

Attribute	Meaning
Radio Configuration, Frame Configuration, Power Control, Multicast Data Control and Advance tab	See Table 142 PMP 450i AP Radio attributes - 5 GHz on page 7-132.
PMP 430 SM Registration	
PMP 450/430 Legacy Mode	
Control Messages	
PMP 430 Interop Mode	See Table 142 PMP 450i AP Radio attributes - 5 GHz on page 7-132.
Receive Quality Debug	
Frame Alignment Legacy Mode	

Radio page - PMP 450 AP 3.65 GHz

Table 149 PMP 450 AP Radio attributes - 3.65 GHz

Radio Configuration	
Frequency Carrier :	3650.000 ▾
Channel Bandwidth :	20 MHz ▾
Cyclic Prefix :	One Sixteenth ▾
Frame Period :	<input type="radio"/> 5.0 ms <input checked="" type="radio"/> 2.5 ms
Color Code :	5 (0—254)
Subscriber Color Code Rescan (When not on a Primary Color Code) :	0 Minutes (0 — 43200)
Subscriber Color Code Wait Period for Idle :	0 Minutes (0 — 60)
Installation Color Code :	<input type="radio"/> Enabled <input checked="" type="radio"/> Disabled

Frame Configuration	
Max Range :	2 Miles (Range: 1 — 40 miles)
Downlink Data :	75 % (Range: 15 — 85 %)
Contention Slots :	3 (Range: 1 — 15)
Broadcast Repeat Count :	2 (Range : 0 — 2)

Power Control	
Transmit Power :	25 dBm (Range: -30 — +25 dBm) (22 dBm A / 22 dBm B)
External Gain :	0 dB (Range: 0 — +70 dB)
SM Receive Target Level :	-52 dBm (Range : -77 — -37 dBm) combined power
Adjacent Channel Support :	<input type="radio"/> Enabled <input checked="" type="radio"/> Disabled

Multicast Data Control	
Multicast VC Data Rate :	Disable ▾
Multicast Repeat Count :	0 (Range : 0 — 2)
Multicast Downlink CIR :	0 (kbps) (Range: 0— 0 kbps)

Advanced	
Control Messages :	<input type="radio"/> SISO <input checked="" type="radio"/> MIMO-A
Receive Quality Debug :	<input type="radio"/> Enabled <input checked="" type="radio"/> Disabled

Attribute	Meaning
Radio Configuration, Frame Configuration, Power Control, Multicast Data Control and Advance tab	See Table 142 PMP 450i AP Radio attributes - 5 GHz on page 7-132.



Note

When the Channel bandwidth is updated from 20 MHz to 30 MHz not more than 59 subscriber can be registered.

Radio page - PMP 450 AP 3.5 GHz

Table 150 PMP 450 AP Radio attributes - 3.5 GHz

Radio Configuration	
Frequency Carrier :	3590.001 ▼
Channel Bandwidth :	10 MHz ▼
Cyclic Prefix :	One Sixteenth ▼
Frame Period :	<input type="radio"/> 5.0 ms <input checked="" type="radio"/> 2.5 ms
Color Code :	35 (0—254)
Subscriber Color Code Rescan (When not on a Primary Color Code) :	1 Minutes (0 — 43200)
Subscriber Color Code Wait Period for Idle :	0 Minutes (0 — 60)
Installation Color Code :	<input type="radio"/> Enabled <input checked="" type="radio"/> Disabled

Frame Configuration	
Max Range :	2 Miles (Range: 1 — 40 miles)
Downlink Data :	85 % (Range: 15 — 85 %)
Contention Slots :	3 (Range: 1 — 15)
Broadcast Repeat Count :	2 (Range : 0 — 2)

Power Control	
Transmit Power :	25 dBm (Range: -30 — +25 dBm) (22 dBm A / 22 dBm B)
External Gain :	0 dB (Range: 0 — +70 dB)
SM Receive Target Level :	-52 dBm (Range : -77 — -37 dBm) combined power
Adjacent Channel Support :	<input type="radio"/> Enabled <input checked="" type="radio"/> Disabled

Multicast Data Control	
Multicast VC Data Rate :	Disable ▼
Multicast Repeat Count :	0 (Range : 0 — 2)
Multicast Downlink CIR :	0 (kbps) (Range: 0— 0 kbps)

Advanced	
Control Messages :	<input type="radio"/> SISO <input checked="" type="radio"/> MIMO-A
Receive Quality Debug :	<input type="radio"/> Enabled <input checked="" type="radio"/> Disabled

Attribute	Meaning
Radio Configuration, Frame Configuration, Power Control, Multicast Data Control and Advance tab	See Table 142 PMP 450i AP Radio attributes - 5 GHz on page 7-132.

Radio page - PMP 450 AP 2.4 GHz

Table 151 PMP 450 AP Radio attributes - 2.4 GHz

Radio Configuration	
Frequency Carrier :	2440.0 ▾
Channel Bandwidth :	20 MHz ▾
Cyclic Prefix :	One Sixteenth ▾
Frame Period :	<input type="radio"/> 5.0 ms <input checked="" type="radio"/> 2.5 ms
Color Code :	24 (0—254)
Subscriber Color Code Rescan (When not on a Primary Color Code) :	0 Minutes (0 — 43200)
Subscriber Color Code Wait Period for Idle :	0 Minutes (0 — 60)
Installation Color Code :	<input checked="" type="radio"/> Enabled <input type="radio"/> Disabled

Frame Configuration	
Max Range :	30 Miles (Range: 1 — 40 miles)
Downlink Data :	75 % (Range: 15 — 85 %)
Contention Slots :	3 (Range: 1 — 15)
Broadcast Repeat Count :	2 (Range : 0 — 2)

Power Control	
Transmit Power :	22 dBm (Range: -30 — +22 dBm) (19 dBm A / 19 dBm B)
External Gain :	35 dB (Range: 0 — +35 dB)
SM Receive Target Level :	-52 dBm (Range : -77 — -37 dBm) combined power

Multicast Data Control	
Multicast VC Data Rate :	Disable ▾
Multicast Repeat Count :	0 (Range : 0 — 2)
Multicast Downlink CIR :	0 (kbps) (Range: 0— 0 kbps)

Advanced	
Control Messages :	<input type="radio"/> SISO <input checked="" type="radio"/> MIMO-A
Receive Quality Debug :	<input checked="" type="radio"/> Enabled <input type="radio"/> Disabled

Attribute	Meaning
Radio Configuration, Frame Configuration, Power Control, Multicast Data Control and Advance tab	See Table 142 PMP 450i AP Radio attributes - 5 GHz on page 7-132.

Radio page - PMP 450 SM 5 GHz

Table 152 PMP 450 SM Radio attributes – 5 GHz

Radio Configuration ☰

5.4 GHz

<input type="checkbox"/> 5472.5	<input type="checkbox"/> 5475.0	<input type="checkbox"/> 5477.5	<input type="checkbox"/> 5480.0	<input type="checkbox"/> 5482.5	<input type="checkbox"/> 5485.0
<input type="checkbox"/> 5487.5	<input type="checkbox"/> 5490.0	<input type="checkbox"/> 5492.5	<input type="checkbox"/> 5495.0	<input type="checkbox"/> 5497.5	<input type="checkbox"/> 5500.0
<input type="checkbox"/> 5502.5	<input type="checkbox"/> 5505.0	<input type="checkbox"/> 5507.5	<input type="checkbox"/> 5510.0	<input type="checkbox"/> 5512.5	<input type="checkbox"/> 5515.0
<input type="checkbox"/> 5517.5	<input type="checkbox"/> 5520.0	<input type="checkbox"/> 5522.5	<input type="checkbox"/> 5525.0	<input type="checkbox"/> 5527.5	<input type="checkbox"/> 5530.0
<input type="checkbox"/> 5532.5	<input type="checkbox"/> 5535.0	<input type="checkbox"/> 5537.5	<input type="checkbox"/> 5540.0	<input type="checkbox"/> 5542.5	<input type="checkbox"/> 5545.0
<input type="checkbox"/> 5547.5	<input type="checkbox"/> 5550.0	<input type="checkbox"/> 5552.5	<input type="checkbox"/> 5555.0	<input type="checkbox"/> 5557.5	<input type="checkbox"/> 5560.0
<input type="checkbox"/> 5562.5	<input type="checkbox"/> 5565.0	<input type="checkbox"/> 5567.5	<input type="checkbox"/> 5570.0	<input type="checkbox"/> 5572.5	<input type="checkbox"/> 5575.0
<input type="checkbox"/> 5577.5	<input type="checkbox"/> 5580.0	<input type="checkbox"/> 5582.5	<input type="checkbox"/> 5585.0	<input type="checkbox"/> 5587.5	<input type="checkbox"/> 5590.0
<input type="checkbox"/> 5592.5	<input type="checkbox"/> 5595.0	<input type="checkbox"/> 5597.5	<input type="checkbox"/> 5600.0	<input type="checkbox"/> 5602.5	<input type="checkbox"/> 5605.0
<input type="checkbox"/> 5607.5	<input type="checkbox"/> 5610.0	<input type="checkbox"/> 5612.5	<input type="checkbox"/> 5615.0	<input type="checkbox"/> 5617.5	<input type="checkbox"/> 5620.0
<input type="checkbox"/> 5622.5	<input type="checkbox"/> 5625.0	<input type="checkbox"/> 5627.5	<input type="checkbox"/> 5630.0	<input type="checkbox"/> 5632.5	<input type="checkbox"/> 5635.0
<input type="checkbox"/> 5637.5	<input type="checkbox"/> 5640.0	<input type="checkbox"/> 5642.5	<input type="checkbox"/> 5645.0	<input type="checkbox"/> 5647.5	<input type="checkbox"/> 5650.0
<input type="checkbox"/> 5652.5	<input type="checkbox"/> 5655.0	<input type="checkbox"/> 5657.5	<input type="checkbox"/> 5660.0	<input type="checkbox"/> 5662.5	<input type="checkbox"/> 5665.0
<input type="checkbox"/> 5667.5	<input type="checkbox"/> 5670.0	<input type="checkbox"/> 5672.5	<input type="checkbox"/> 5675.0	<input type="checkbox"/> 5677.5	<input type="checkbox"/> 5680.0
<input type="checkbox"/> 5682.5	<input type="checkbox"/> 5685.0	<input type="checkbox"/> 5687.5	<input checked="" type="checkbox"/> 5690.0	<input type="checkbox"/> 5692.5	<input type="checkbox"/> 5695.0
<input type="checkbox"/> 5697.5	<input type="checkbox"/> 5700.0	<input type="checkbox"/> 5702.5	<input type="checkbox"/> 5705.0	<input type="checkbox"/> 5707.5	<input type="checkbox"/> 5710.0
<input type="checkbox"/> 5712.5	<input type="checkbox"/> 5715.0	<input type="checkbox"/> 5717.5	<input type="checkbox"/> 5720.0	<input type="checkbox"/> 5722.5	

Custom Radio Frequency Scan Selection List : 5.7 GHz

<input type="checkbox"/> 5727.5	<input type="checkbox"/> 5730.0	<input type="checkbox"/> 5732.5	<input type="checkbox"/> 5735.0	<input type="checkbox"/> 5737.5	<input type="checkbox"/> 5740.0
<input type="checkbox"/> 5742.5	<input type="checkbox"/> 5745.0	<input type="checkbox"/> 5747.5	<input type="checkbox"/> 5750.0	<input type="checkbox"/> 5752.5	<input checked="" type="checkbox"/> 5755.0
<input type="checkbox"/> 5757.5	<input type="checkbox"/> 5760.0	<input type="checkbox"/> 5762.5	<input type="checkbox"/> 5765.0	<input type="checkbox"/> 5767.5	<input type="checkbox"/> 5770.0
<input type="checkbox"/> 5772.5	<input type="checkbox"/> 5775.0	<input type="checkbox"/> 5777.5	<input type="checkbox"/> 5780.0	<input type="checkbox"/> 5782.5	<input type="checkbox"/> 5785.0
<input type="checkbox"/> 5787.5	<input checked="" type="checkbox"/> 5790.0	<input type="checkbox"/> 5792.5	<input type="checkbox"/> 5795.0	<input type="checkbox"/> 5797.5	<input type="checkbox"/> 5800.0
<input type="checkbox"/> 5802.5	<input type="checkbox"/> 5805.0	<input type="checkbox"/> 5807.5	<input type="checkbox"/> 5810.0	<input type="checkbox"/> 5812.5	<input type="checkbox"/> 5815.0
<input type="checkbox"/> 5817.5	<input type="checkbox"/> 5820.0	<input type="checkbox"/> 5822.5	<input type="checkbox"/> 5825.0	<input type="checkbox"/> 5827.5	<input type="checkbox"/> 5830.0
<input type="checkbox"/> 5832.5	<input type="checkbox"/> 5835.0	<input type="checkbox"/> 5837.5	<input type="checkbox"/> 5840.0	<input type="checkbox"/> 5842.5	<input type="checkbox"/> 5845.0
<input type="checkbox"/> 5847.5	<input type="checkbox"/> 5850.0	<input type="checkbox"/> 5852.5	<input type="checkbox"/> 5855.0	<input type="checkbox"/> 5857.5	<input type="checkbox"/> 5860.0
<input type="checkbox"/> 5862.5	<input type="checkbox"/> 5865.0	<input type="checkbox"/> 5867.5	<input type="checkbox"/> 5870.0	<input type="checkbox"/> 5872.5	<input type="checkbox"/> 5875.0
<input type="checkbox"/> 5877.5	<input type="checkbox"/> 5880.0	<input type="checkbox"/> 5882.5	<input type="checkbox"/> 5885.0	<input type="checkbox"/> 5887.5	<input type="checkbox"/> 5890.0
<input type="checkbox"/> 5892.5	<input type="checkbox"/> 5895.0	<input type="checkbox"/> 5897.5			

5 MHz only

<= 10 MHz

<=15 MHz

<=20 MHz

<=30 MHz

FCC TDWR Band

Not available in this region

Channel Bandwidth Scan :	<input type="checkbox"/> 5 MHz <input type="checkbox"/> 10 MHz <input type="checkbox"/> 15 MHz <input checked="" type="checkbox"/> 20 MHz <input type="checkbox"/> 30 MHz <input checked="" type="checkbox"/> 40 MHz
Cyclic Prefix :	One Sixteenth
AP Selection Method :	<input type="radio"/> Power Level <input checked="" type="radio"/> Optimize for Throughput
Color Code 1 :	212 (0—254) / Priority Primary ▾
Installation Color Code :	<input checked="" type="radio"/> Enabled <input type="radio"/> Disabled
Large VC data Q :	<input type="radio"/> Enabled <input checked="" type="radio"/> Disabled

Additional Color Codes

Color Code : (0—254) / Priority Primary ▾

Additional Color Codes Table

Color Code	Priority
0	Primary
10	Primary
20	Primary
30	Secondary
50	Tertiary
100	Tertiary
120	Primary
130	Secondary
140	Secondary
1	Primary
200	Secondary

Power Control

External Gain : dBi (Range: 0 — +40 dBi)

Advanced

Receive Quality Debug : Enabled
 Disabled

Attribute	Meaning
Custom Radio Frequency Scan Selection List	Check the frequencies that SM has to scan for AP transmissions. See Radio Frequency Scan Selection List on page 7-169.

See [Table 142 PMP 450i AP Radio attributes - 5 GHz](#) on page 7-132.

Radio page - PMP 450 SM 3.65 GHz

Table 153 PMP 450 SM Radio attributes – 3.65 GHz

Radio Configuration

	<input type="checkbox"/> 3502.500 <input type="checkbox"/> 3503.500 <input type="checkbox"/> 3505.000 <input type="checkbox"/> 3507.500 <input type="checkbox"/> 3510.000 <input type="checkbox"/> 3515.000 <input type="checkbox"/> 3552.500 <input type="checkbox"/> 3553.500 <input type="checkbox"/> 3555.000 <input type="checkbox"/> 3557.500 <input type="checkbox"/> 3560.000 <input type="checkbox"/> 3565.000 <input checked="" type="checkbox"/> 3600.000 <input checked="" type="checkbox"/> 3602.500 <input checked="" type="checkbox"/> 3603.500 <input checked="" type="checkbox"/> 3605.000 <input checked="" type="checkbox"/> 3607.500 <input checked="" type="checkbox"/> 3610.000 <input checked="" type="checkbox"/> 3615.000 <input checked="" type="checkbox"/> 3640.000 <input checked="" type="checkbox"/> 3642.500 <input checked="" type="checkbox"/> 3645.000 <input checked="" type="checkbox"/> 3646.500 <input checked="" type="checkbox"/> 3647.500 <input checked="" type="checkbox"/> 3650.000 <input checked="" type="checkbox"/> 3650.010 <input checked="" type="checkbox"/> 3652.500 <input checked="" type="checkbox"/> 3653.000 <input checked="" type="checkbox"/> 3653.500 <input checked="" type="checkbox"/> 3655.000 <input checked="" type="checkbox"/> 3657.000 <input checked="" type="checkbox"/> 3657.500 <input checked="" type="checkbox"/> 3660.000 <input checked="" type="checkbox"/> 3675.000 <input checked="" type="checkbox"/> 3690.000 <input checked="" type="checkbox"/> 3692.000 <input type="checkbox"/> 3692.500 <input type="checkbox"/> 3695.000 <input type="checkbox"/> 3696.000 <input type="checkbox"/> 3696.500 <input type="checkbox"/> 3697.000 <input type="checkbox"/> 3697.500 <input type="checkbox"/> 3700.000 <input type="checkbox"/> 3735.000 <input type="checkbox"/> 3740.000 <input type="checkbox"/> 3742.500 <input type="checkbox"/> 3745.000 <input type="checkbox"/> 3746.500 <input type="checkbox"/> 3747.500 <input type="checkbox"/> 3750.000 <input checked="" type="checkbox"/> 3785.000 <input checked="" type="checkbox"/> 3790.000 <input checked="" type="checkbox"/> 3792.500 <input checked="" type="checkbox"/> 3795.000 <input checked="" type="checkbox"/> 3796.500 <input checked="" type="checkbox"/> 3797.500 <input type="checkbox"/> 3800.000
Custom Radio Frequency Scan Selection List :	<div style="font-size: 0.8em; margin-bottom: 5px;"> 5 MHz only ≤7 MHz ≤10 MHz ≤15 MHz ≤20 MHz </div> <div style="font-size: 0.7em; margin-bottom: 5px;"> Not available in this region <input type="button" value="Select All"/> <input type="button" value="Clear All"/> <input type="button" value="Restore"/> </div>
Channel Bandwidth Scan :	<input checked="" type="checkbox"/> 5 MHz <input type="checkbox"/> 7 MHz <input type="checkbox"/> 10 MHz <input type="checkbox"/> 15 MHz <input type="checkbox"/> 20 MHz <input type="checkbox"/> 30 MHz
Cyclic Prefix Scan :	<input checked="" type="checkbox"/> One Sixteenth
AP Selection Method :	<input type="radio"/> Power Level <input checked="" type="radio"/> Optimize for Throughput
Color Code 1 :	0 (0—254) / Priority Primary
Installation Color Code :	<input checked="" type="radio"/> Enabled <input type="radio"/> Disabled
Large VC data Q :	<input type="radio"/> Enabled <input checked="" type="radio"/> Disabled

Additional Color Codes

Color Code :	0 (0—254) / Priority Primary
<input type="button" value="Add/Modify Color Code"/> <input type="button" value="Remove Color Code"/>	

Additional Color Codes Table

No additional color codes configured

Power Control

External Gain :	0 dBi (Range: 0 — +70 dBi)
-----------------	------------------------------

Advanced

Receive Quality Debug :	<input type="radio"/> Enabled <input checked="" type="radio"/> Disabled
-------------------------	--

Attribute	Meaning
Custom Radio Frequency Scan Selection List	Check the frequencies that SM has to scan for AP transmissions. See Radio Frequency Scan Selection List on page 7-169.

See [Table 142 PMP 450i AP Radio attributes - 5 GHz](#) on page 7-132.