



Wireless Access Point  
X2 and XD2 Series  
Quick Installation Guide

August 8, 2015

 is a registered trademark of Xirrus, Inc. All other trademarks and brand names are marks of their respective holders.

Please see Legal Notices, Warnings, Compliance Statements, and Warranty and License Agreements in the *Xirrus Wireless AP User's Guide*.

All rights reserved. This document may not be reproduced or disclosed in whole or in part by any means without the written consent of Xirrus, Inc.

Part Number: 812-0085-012 Rev A August 8, 2015

# Quick Installation Guide

## For X2 and XD2 Series Models

X2 and XD2 Series Access Points (APs) are new classes of APs within the Xirrus wireless portfolio. With two omnidirectional 802.11ac radios, a powerful integrated controller, application-level intelligence, and optional cloud management, the APs deliver robust wireless connectivity in areas of medium to high user density. The XD2-240 AP has two 802.11ac Wave 2 radios, while the X2-120 has two Wave 1 radios.



The X2 Series includes the X2-120 (Model X2120). The XD2 Series includes the XD2-240 (Model XD2240).

This Guide covers the steps required to install and start these APs. For detailed configuration information, see the *Xirrus Wireless AP User's Guide*.

# 1

## You Need the Following Items

- ◆ Power and Ethernet connection(s) to your wired network using Cat 5e or Cat 6 cables:
  - ◆ **GIG1/POE**—This Gigabit port powers the AP via Power over Ethernet (PoE) using a Cat 5e or Cat 6 cable that also carries data traffic. See below for Power details.
  - ◆ **GIG2**—This second, data-only Gigabit port is only available on the XD2, and provides additional bandwidth. Its use is optional. Connect with Cat 5E or Cat 6 cable.

*AP must be connected to PoE networks without routing cabling to the outside plant. This ensures that cabling is not exposed to lightning strikes or possible crossover from high voltage lines. AP, PoE Injectors, and Switches must be installed and used indoors. The total Cat 5e or Cat 6 cable length from the switch to the AP must be no more than 100 m, including all cable segments.*

- ◆ Power— See the matrix below to select a compatible PoE switch or Xirrus-supplied injector for your AP. X2 models are IEEE802.3af-compatible, while XD2 models require 802.3at. If using an injector, you must provide a data connection from the switch to the injector as well as another cable from the injector's OUT port to the AP's GIG1/POE port.

AP Type	Generic PoE Injector or Switch (802.3af)	Generic PoE+ Injector or Switch (802.3at)	Xirrus PoE+ Switch (802.3at)	XP1-MSI-20	XP1-MSI-30	XP1-MSI-75M	XP1-MSI-75 (POE-75U-1UP-X)	XP8-MSI-70M	XP2-MSI-95M
X2	✓	✓	✓	✓	✓	✓	✓	✓	✓
XD2		✓	✓		✓	✓	✓	✓	✓

- ◆ Apply power to GIG1/POE port only—other AP Gigabit ports will not draw power if connected to a powered switch port, and AP LEDs will not light.
- ◆ If you are using a POE switch, it is imperative that you know that the switch has sufficient power budget to power all connected devices.

## X2 and XD2 Two-Radio Access Points

- ◆ All Xirrus XD2 APs are Type 2, Class 4 POE-802.3at devices. If your switch vendor provides a setting for the type of powered-device detection with options such as Legacy, 4-Point, or BOTH, set the port to BOTH or 4-Point. Do not use settings intended for legacy devices.
- ◆ Access to a Web browser to configure the AP via the Xirrus Management System or directly via the AP's Windows Management Interface (WMI).
- ◆ For a suspended ceiling mount, you need a 7/16" nut driver to attach the mounting plate to the T-Bar clips. (See "Install Mounting Hardware and AP" on page 3.) Do not use old T-bar clips or studs from XN or XS APs with the X2 and XD2 Series—they will damage the AP case.
- ◆ For a locked installation, supply a zip-tie, small lock, or other locking hardware.

**NOTE:** Leave protective plastic film on the AP until installation is complete, to avoid leaving marks on the AP.

### Mounting Options

- ◆ Direct Ceiling Mount—for the ability to lock the AP in place or detect tampering, use the furnished mounting plate with at least two user-supplied screws.

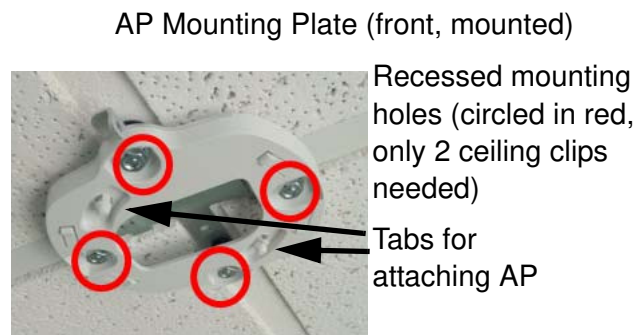
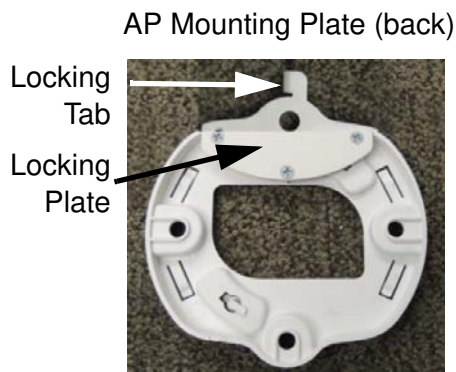

- ◆ Suspended Ceiling Grid Mount—See photos above and on [page 3](#). Use the mounting plate with the two supplied T-Bar clips (for 15/16" ceiling grid). For a slotted ceiling grid, T-slot bolts are available for attaching the mounting plate to slots in the grid.
- ◆ Wall Mount—use a Wall Mount Kit (XE-500-WALL), which contains a mounting plate, wall mount bracket, and three screws (1/4" Plastite).

## 2

### Choose a Suitable Location

- ◆ Choose an indoor location that is central to your users, that is away from heat sources. To ensure good air flow, it is essential that the AP's vents are not blocked.
- ◆ The AP should be installed parallel to the ground (i.e., in a horizontal position, not tilted on its side). The AP should not be more than 30 feet above the ground (or the level at which receiving devices will be used). For atypical installations, please verify the resulting signal coverage.
- ◆ The location must be capable of supporting the weight of the AP and the mounting bracket (about 2 lb total).
- ◆ For optimal placement, we recommend that a predictive survey be performed by a qualified Xirrus partner.
- ◆ Maintain a distance of at least 50 feet between additional APs.
- ◆ Keep the unit away from electrical devices or appliances that generate RF noise—at least 3 to 6 ft (1m - 2m).

# 3

## Install Mounting Hardware and AP

- ◆ 3A—Ceiling Mount with Mounting Plate
- ◆ 3B—Ceiling Grid Mount with Mounting Plate
- ◆ 3C—Wall Mount with Bracket

### 3A—Ceiling Mount with Mounting Plate

The following steps use a mounting plate, which offers a more secure mount, ease of dismount, and a locking option for the AP.

1. Use the holes on the AP mounting plate to mark the placement of at least two user-supplied screws to install in the ceiling.
2. Drill and prepare holes for the screws as appropriate.
3. Cut an access hole for the cable(s) in the ceiling and draw enough cable through to attach to the AP after it is installed.
4. Align the AP mounting plate over the prepared holes, with the metal locking plate against the ceiling. Secure the plate with the screws. Do not over-tighten.
5. Proceed to “Connect Cables and Install AP” on page 4.



### 3B—Ceiling Grid Mount with Mounting Plate

1. For T-Bar clips, use two of the four holes on the AP mounting plate to mark the placement of two T-bar clips on the metal ceiling support grid.

Twist the two supplied T-bar clips onto the metal ceiling grid at the marked locations and tighten the screw posts to 10-12 lbf.ft (1.38-1.66 kgf.m). Do not over-tighten the screw posts.

T-Bar Clips  
(4 shown; only 2 needed)



2. Cut an access hole in the ceiling tile and draw the cable(s) through.
3. Align the AP mounting plate over the screw posts of the T-Bar bracket or clips and secure it to the two posts using the nuts provided. Tighten the nuts to 10-12 lbf.ft (1.38-1.66 kgf.m), but do not over-tighten.
4. Proceed to “Connect Cables and Install AP” on page 4.



### 3C—Wall Mount with Bracket

*NOTE: The mounting location must be able to support the weight of the AP and the mounting bracket (about 2 lb. total).*

1. If the AP mounting plate has a metal locking plate, remove it. Align the three holes in the wall bracket over the corresponding mounting plate holes. The wall bracket's small locking tab should point down toward the mounting plate.

*NOTE: Use only the screws provided in the accessory kit. Other screws that seem equivalent in size may damage the mounting plate.*

2. Use the three screws provided in the accessory kit to attach the wall mount bracket to the AP mounting plate as shown here.
3. Use the Wall Mounting Bracket as a template and mark the locations on the wall for the mounting holes. The bracket must be secured to the wall in 3 places. When marking the holes, make sure the mounting plate is level.

4. Attach the mounting plate to the wall with three user-supplied screws appropriate to the wall construction type.

*NOTE: The mounting location must be capable of supporting the weight of the AP and the mounting bracket (about 2 pounds total).*

5. Cut an access hole for the cable(s) in the wall and draw enough cable through to attach to the AP after it is installed.
6. Proceed to "Connect Cables and Install AP" on page 4.



## 4

### Connect Cables and Install AP

1. Connect the cable that carries power and data to **GIG1/POE** (shown in red). If you use a Xirrus-supplied injector, its CONNECT LED should light (for 70W and higher injectors, it is OK if it blinks). If power is being properly supplied, the AP's LEDs will light and then commence blinking in their rotating boot pattern. A second data connection may be plugged into **GIG2** (optional, XD2 only).



## X2 and XD2 Two-Radio Access Points

- Align the two slots on the back of the AP chassis (circled in red) with the corresponding tabs on the AP mounting plate. To assist you in positioning the AP, make sure that the AP's locking slug (red arrow) lines up with the matching locking tab on the wall bracket or mounting plate (see photos in "AP Mounting Plate (back)" on page 2).
- Push the AP chassis up on the mounting plate tabs and rotate the AP to the right until it snaps in place.
- To secure the AP to the mounting plate for tamper evidence or to deter removal, feed a customer-provided zip tie or other locking hardware through the hole in the top of the locking slug (red arrow, photo above) and the matching locking tab on the mounting plate or wall bracket.
- Remove the protective plastic film from the unit.
- You may remove the AP by pushing it up against the mounting plate and rotating to the left.

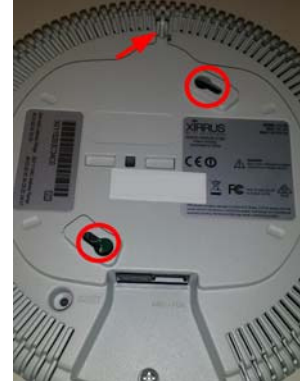

# 5

## Zero-Touch Provisioning and Ongoing Management

Most customers employ the Xirrus Management System (XMS) for the initial setup and continuing management of Xirrus devices. XMS users can readily set up their new devices for provisioning and ongoing maintenance via the following platforms. Newly discovered APs are automatically assigned to the XMS "default" profile, and will receive the configuration defined for that profile.

- ◆ XMS-Cloud—performs zero-touch provisioning as shown in this quick video guide: <http://www.xirrus.com/TV/Training/XMS-cloud-Next-Generation>. Your new APs appear in XMS even before you receive your equipment. When the email arrives with your login information, use XMS-Cloud to specify the initial settings for your APs. A Guided Tour will walk you through the basic steps of creating a profile containing configuration settings, including creating SSIDs and firewall/application control rules. Once the installed AP has Internet connectivity, it will automatically contact Xirrus for cloud-based zero-touch provisioning per your settings, install the latest applicable license, and upgrade the AP to the latest software version as appropriate.
- ◆ XMS-Enterprise—automatically detects and provisions new Xirrus devices deployed in your network via a similar provisioning approach. Set up discovery for your APs' subnetwork, and create and configure a default profile for newly added APs. After discovery, these new devices automatically receive the configuration defined in your default profile.

If you are not using XMS, please see the *Xirrus Wireless AP User's Guide* to configure your AP manually (XD2 only) via the Express Setup menu option. The User Guide is available from <http://support.xirrus.com> (login required). Select the Libraries tab and click the *ArrayOS - XR Platform Latest Release* link.

# 6

## Using the Reset Button

The reset button returns the AP to factory default settings while rebooting. It is located on the bottom of the unit. Use the reset button as follows:

- ◆ Unplug the cable from the **GIG1/POE** port.
- ◆ Press the reset button all the way (there should be a faint click) and hold it.
- ◆ Plug the cable back in and continue to keep the button pressed for 10 seconds. This triggers the factory default reset during the boot process.



# 7

## Specifications and Drawings

### Physical/Environmental Specifications

- ◆ Dimensions (WxDxH, including mounting plate): 8 x 8 x 2.25 in / 20.3 x 20.3 x 5.7 cm
- ◆ Weight: 2 lb / 0.9 kg
- ◆ Operating Temperature: 0-50°C / 32-122°F, 5-95% humidity, non-condensing.

### Mounting Plate

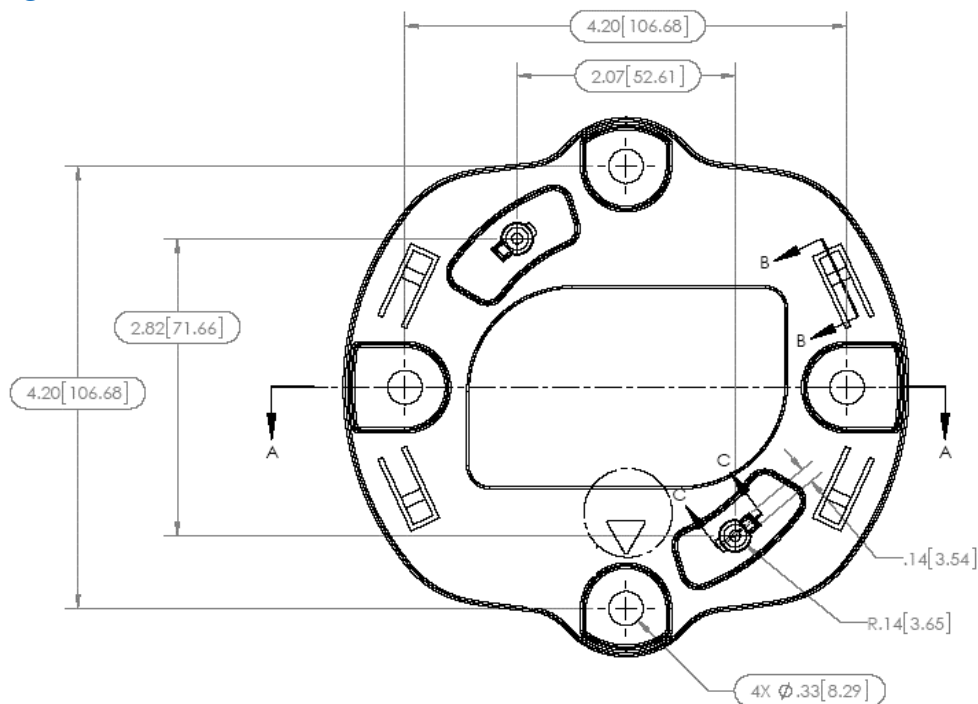



Direct Mounting Template

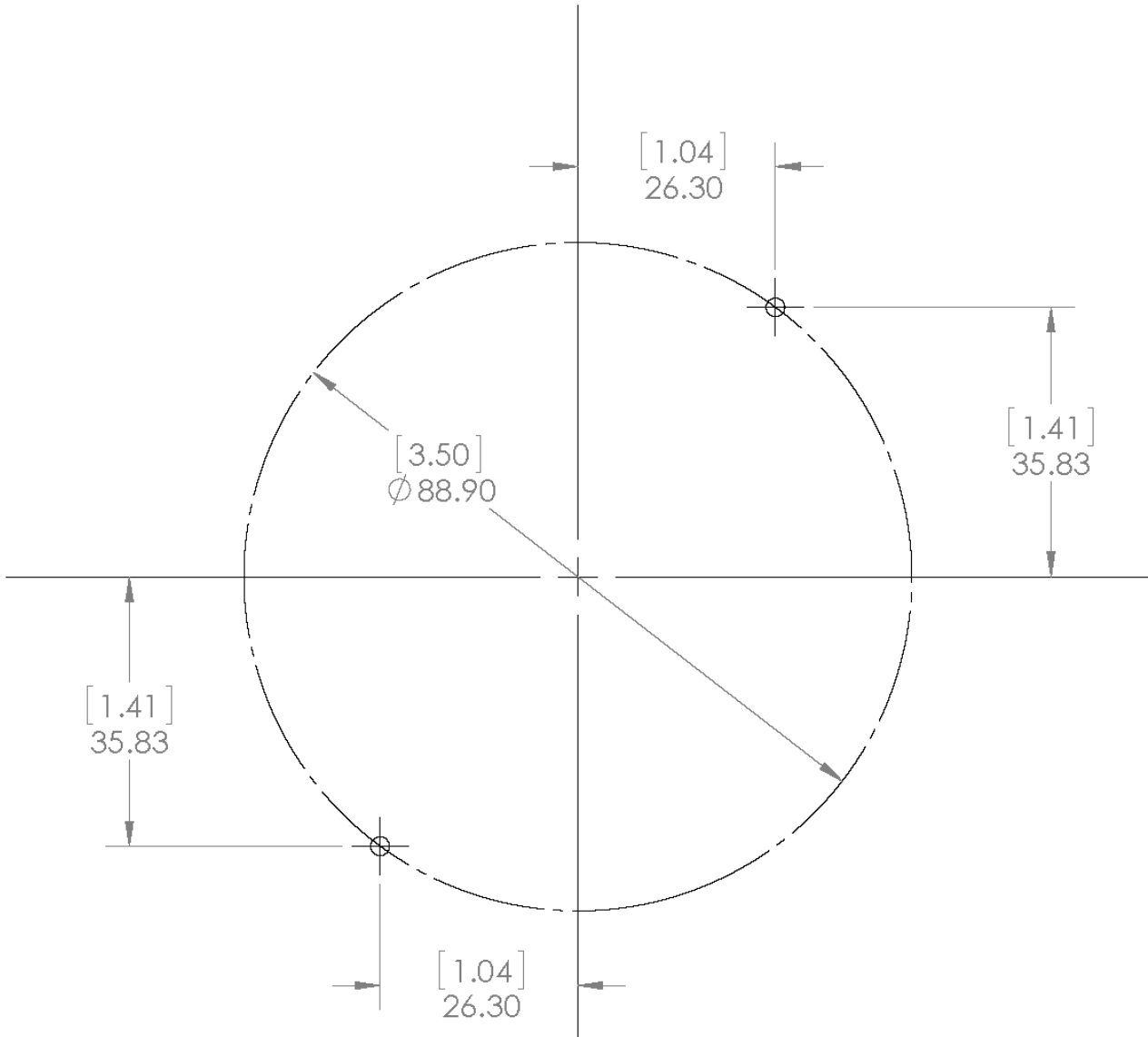



1.800.947.7871 Toll Free in the US  
+1.805.262.1600 Sales  
+1.805.262.1601 Fax  
2101 Corporate Center Drive  
Thousand Oaks, CA 91320, USA

To learn more visit:  
[xirrus.com](http://xirrus.com) or  
email [info@xirrus.com](mailto:info@xirrus.com)

## Appendix C: Notices (XD and XR500/600 Series Only)



*This Appendix contains Notices, Warnings, and Compliance information for the XD and XR500/600 Series only.*

*For Notices, Warnings, and Compliance information for outdoor products, please see the Quick Installation Guide for that product.*

*For Notices, Warnings, and Compliance information for all other APs, please see “Notices (XR-1000 to XR-6000 Indoor Models)” on page 563.*

This appendix contains the following information:

- “Notices” on page 539
- “EU Directive 1999/5/EC Compliance Information” on page 546
- “Compliance Information (Non-EU)” on page 553
- “Safety Warnings” on page 555
- “Translated Safety Warnings” on page 556
- “Software License and Product Warranty Agreement” on page 557
- “Hardware Warranty Agreement” on page 563

### Notices

#### Wi-Fi Alliance Certification



[www.wi-fi.org](http://www.wi-fi.org)

#### FCC Notice

This equipment has been tested and found to comply with the limits for a Class B digital device, pursuant to Part 15 of the FCC rules. These limits are designed to provide reasonable protection against harmful interference in a residential installation. This equipment generates, uses and can radiate RF energy and, if not

installed and used in accordance with the instructions, may cause harmful interference to radio communications. However, there is no guarantee that interference will not occur in a particular installation. If this equipment does cause harmful interference to radio or television reception, which can be determined by turning the equipment off and on, the user is encouraged to try to correct the interference by one or more of the following safety measures:

- Reorient or relocate the receiving antenna.
- Increase the separation between the equipment and the receiver.
- Connect the equipment into an outlet on a circuit different from that to which the receiver is connected.
- Consult the dealer or an experienced wireless technician for help.

! *FCC Caution: Any changes or modifications not expressly approved by the party responsible for compliance could void the user's authority to operate this equipment.*

This device complies with Part 15 of the FCC Rules, with operation subject to the following two conditions: (1) This device may not cause harmful interference, and (2) this device must accept any interference received, including interference that may cause unwanted operation.

For XD2 models available in the USA/Canada market, only channels 1~11 can be operated. Selection of other channels is not possible.

This device and its antenna(s) must not be co-located or operating in conjunction with any other antenna or transmitter except in accordance with FCC multi-transmitter product procedures.

This device is restricted for indoor use.

Use of a shielded twisted pair (STP) cable must be used for all Ethernet connections in order to comply with EMC requirements.

Operations in the 5.15-5.25GHz band are restricted to indoor usage only.

### **IMPORTANT NOTE: FCC Radiation Exposure Statement**

This equipment complies with FCC radiation exposure limits set forth for an uncontrolled environment. To ensure compliance with FCC and Industry Canada

RF exposure requirements, this device must be installed in a location where the antennas of the device will have a minimum distance of at least 30 cm (12 inches) from all persons, except that XD2 models must have a minimum distance of at least 20 cm (8 inches) from all persons. Using higher gain antennas and types of antennas not certified for use with this product is not allowed. The device shall not be co-located with another transmitter.

### High Power Radars

High power radars are allocated as primary users (meaning they have priority) in the 5250MHz to 5350MHz and 5650MHz to 5850MHz bands. These radars could cause interference and/or damage to LE-LAN devices.

### Non-Modification Statement

Unauthorized changes or modifications to the device are not permitted. Use only the supplied internal antenna, or external antennas supplied by the manufacturer. Modifications to the device will void the warranty and may violate FCC regulations.

### Cable Runs for Power over Ethernet (PoE)

If using PoE, the AP must be connected to PoE networks without routing cabling to the outside plant—this ensures that cabling is not exposed to lightning strikes or possible cross over from high voltage.

### Battery Warning

- ! **Caution!** *The AP contains a battery which is not to be replaced by the customer. Danger of Explosion exists if the battery is incorrectly replaced. Replace only with the same or equivalent type recommended by the manufacturer. Dispose of used batteries according to the manufacturer's instructions.*

### UL Statement

Use only with listed ITE product.

### **Industry Canada Statement (XD2)**

This device complies with Industry Canada license-exempt RSS standard(s). Operation is subject to the following two conditions: (1) this device may not cause interference, and (2) this device must accept any interference, including interference that may cause undesired operation of the device.

*Le présent appareil est conforme aux CNR d'Industrie Canada applicables aux appareils radio exempts de licence. L'exploitation est autorisée aux deux conditions suivantes : (1) l'appareil ne doit pas produire de brouillage, et (2) l'utilisateur de l'appareil doit accepter tout brouillage radioélectrique subi, même si le brouillage est susceptible d'en compromettre le fonctionnement.*

For product available in the USA/Canada market, only channel 1~11 can be operated. Selection of other channels is not possible.

*Pour les produits disponibles aux États-Unis / Canada du marché, seul le canal 1 à 11 peuvent être exploités. Sélection d'autres canaux n'est pas possible.*

This device and its antenna(s) must not be co-located or operating in conjunction with any other antenna or transmitter except in accordance with IC multi-transmitter product procedures.

*Cet appareil et son antenne (s) ne doit pas être co-localisés ou fonctionner en association avec une autre antenne ou transmetteur.*

Dynamic Frequency Selection (DFS) for devices operating in the bands 5250- 5350 MHz, 5470-5600 MHz and 5650-5725 MHz

*Sélection dynamique de fréquences (DFS) pour les dispositifs fonctionnant dans les bandes 5250-5350 MHz, 5470-5600 MHz et 5650-5725 MHz*

The device for operation in the band 5150-5250 MHz is only for indoor use to reduce the potential for harmful interference to co-channel mobile satellite systems.

*Les dispositifs fonctionnant dans la bande 5150-5250 MHz sont réservés uniquement pour une utilisation à l'intérieur afin de réduire les risques de brouillage préjudiciable aux systèmes de satellites mobiles utilisant les mêmes canaux.*

Users should also be advised that high-power radars are allocated as primary users (i.e. priority users) of the bands 5250-5350 MHz and 5650-5850 MHz and that these radars could cause interference and/or damage to LE-LAN devices.

*De plus, les utilisateurs devraient aussi être avisés que les utilisateurs de radars de haute puissance sont désignés utilisateurs principaux (c.-à-d., qu'ils ont la priorité) pour les bandes 5250-5350 MHz et 5650-5850 MHz et que ces radars pourraient causer du brouillage et/ou des dommages aux dispositifs LAN-EL.*

For indoor use only.

*Pour une utilisation en intérieur uniquement.*

### **IMPORTANT NOTE:**

#### **IC Radiation Exposure Statement:**

This equipment complies with IC RSS-102 radiation exposure limits set forth for an uncontrolled environment. This equipment should be installed and operated with minimum distance 20 cm between the radiator and your body.

*Cet équipement est conforme aux limites d'exposition aux rayonnements IC établies pour un environnement non contrôlé. Cet équipement doit être installé et utilisé avec un minimum de 20 cm de distance entre la source de rayonnement et votre corps.*

**Industry Canada Statement (non-XD2)**

This device complies with RSS-210 of the Industry Canada Rules. Operation is subject to the following two conditions: (1) This device may not cause harmful interference, and (2) this device must accept any interference received, including interference that may cause undesired operation.

*Ce dispositif est conforme à la norme CNR-210 d'Industrie Canada applicable aux appareils radio exempts de licence. Son fonctionnement est sujet aux deux conditions suivantes: (1) le dispositif ne doit pas produire de brouillage préjudiciable, et (2) ce dispositif doit accepter tout brouillage reçu, y compris un brouillage susceptible de provoquer un fonctionnement indésirable.*

**Caution:**

(i) the device for operation in the band 5150-5250 MHz is only for indoor use to reduce the potential for harmful interference to co-channel mobile satellite systems;

(ii) high-power radars are allocated as primary users (i.e. priority users) of the bands 5250-5350 MHz and 5650-5850 MHz and that these radars could cause interference and/or damage to LE-LAN devices.

When operating the XR-600 Series in the band 5250-5350 MHz with a maximum e.i.r.p. greater than 200 mW in Canada, please adjust antenna/EUT to comply with the following e.i.r.p. elevation mask, where  $\theta$  is the angle above the local horizontal plane (of the Earth) as shown below:

(i) -13 dB(W/MHz) for  $0^\circ \leq \theta < 8^\circ$

(ii) -13 - 0.716 ( $\theta$ -8) dB(W/MHz) for  $8^\circ \leq \theta < 40^\circ$

(iii) -35.9 - 1.22 ( $\theta$ -40) dB(W/MHz) for  $40^\circ \leq \theta \leq 45^\circ$

(iv) -42 dB(W/MHz) for  $\theta > 45^\circ$

**Avertissement:**

*(i) les dispositifs fonctionnant dans la bande 5 150-5 250 MHz sont réservés uniquement pour une utilisation à l'intérieur afin de réduire les risques de brouillage préjudiciable aux systèmes de satellites mobiles utilisant les mêmes canaux;*

*(ii) De plus, les utilisateurs devraient aussi être avisés que les utilisateurs de radars de haute puissance sont désignés utilisateurs principaux (c.-à-d., qu'ils ont la priorité) pour*



*les bandes 5 250-5 350 MHz et 5 650-5 850 MHz et que ces radars pourraient causer du brouillage et/ou des dommages aux dispositifs LAN-EL.*

**IMPORTANT NOTE:**

**IC Radiation Exposure Statement:**

To ensure compliance with Industry Canada RF exposure requirements, this device must be installed in a location where the antennas of the device will have a minimum distance of at least 30 cm (12 inches) from all persons. Using higher gain antennas and types of antennas not certified for use with this product is not allowed. The device shall not be co-located with another transmitter.

*Installez l'appareil en veillant à conserver une distance d'au moins 30 cm entre les éléments rayonnants et les personnes. Cet avertissement de sécurité est conforme aux limites d'exposition définies par la norme CNR-102 at relative aux fréquences radio.*

## EU Directive 1999/5/EC Compliance Information



*This Appendix contains Notices, Warnings, and Compliance information for the XD and XR500/600 Series only. For other models, see the notes under “Notices (XR-1000 to XR-6000 Indoor Models)” on page 563.*

This section contains compliance information for the Xirrus Wireless AP family of products. The compliance information contained in this section is relevant to the European Union and other countries that have implemented the EU Directive 1999/5/EC.

### Declaration of Conformity

- Cesky [Czech]** Toto zahzení je v souladu se základními požadavky a ostatními odpovídajícími ustanoveními Směrnice 1999/5/EC.
- Dansk [Danish]** Dette udstyr er i overensstemmelse med de væsentlige krav og andre relevante bestemmelser i Direktiv 1999/5/EF.
- Deutsch [German]** Dieses Gerät entspricht den grundlegenden Anforderungen und den weiteren entsprechenden Vorgaben der Richtlinie 1999/5/EU.
- Eesti [Estonian]** See seande vastab direktiivi 1999/5/EU oluliste nõuetele ja teistele asjakohastele sätetele.
- English** This equipment is in compliance with the essential requirements and other relevant provisions of Directive 1999/5/EC.
- Español [Spain]** Este equipo cumple con los requisitos esenciales así como con otras disposiciones de la Directiva 1999/5/CE.
- Ελληνική [Greek]** Αυτός ο εξοπλισμός είναι σε συμμόρφωση με τις ουσιαστικές απαιτήσεις και άλλες σχετικές διατάξεις της Οδηγίας 1999/5/EC.

- Français [French]** Cet appareil est conforme aux exigences essentielles et aux autres dispositions pertinentes de la Directive 1999/5/EC.
- Íslenska [Icelandic]** Þetta tæki er samkvæmt grunnkröfum og öðrum viðeigandi ákvæðum Tilskipunar 1999/5/EC.
- Italiano [Italian]** Questo apparato é conforme ai requisiti essenziali ed agli altri principi sanciti dalla Direttiva 1999/5/CE.
- Latviski [Latvian]** Šī iekārta atbilst Direktīvas 1999/5/EK būtiskajā prasībām un citiem ar to saistītajiem noteikumiem.
- Lietuvių [Lithuanian]** Šis įrenginys tenkina 1999/5/EB Direktyvos esminius reikalavimus ir kitas šios direktyvos nuostatas.
- Nederlands [Dutch]** Dit apparant voldoet aan de essentiële eisen en andere van toepassing zijnde bepalingen van de Richtlijn 1999/5/EC.
- Malti [Maltese]** Dan l-apparant huwa konformi mal-htigiet essenzjali u l-provedimenti l-oħra rilevanti tad-Direttiva 1999/5/EC.
- Magyar [Hungarian]** Ez a készülék teljesíti az alapvető követelményeket és más 1999/5/EK irányelvben meghatározott vonatkozó rendelkezéseket.
- Norsk [Norwegian]** Dette utstyret er i samsvar med de grunnleggende krav og andre relevante bestemmelser i EU-direktiv 1999/5/EF.
- Polski [Polish]** Urządzenie jest zgodne z ogólnymi wymaganiami oraz szczególnymi mi warunkami określony mi Dyrektywą. UE:1999/5/EC.
- Português [Portuguese]** Este equipamento está em conformidade com os requisitos essenciais e outras provisões relevantes da Directiva 1999/5/EC.

- Slovensko [Slovenian]** Ta naprava je skladna z bistvenimi zahtevami in ostalimi relevantnimi popoji Direktive 1999/5/EC.
- Slovensky [Slovak]** Toto zariadenie je v zhode so základnými požiadavkami a inými príslušnými nariadeniami direktiv: 1999/5/EC.
- Suomi [Finnish]** Tämä laite täyttää direktiivin 1999/5//EY olennaiset vaatimukset ja on siinä asetettujen muiden laitetta koskevien määräysten mukainen.
- Svenska [Swedish]** Denna utrustning är i överensstämmelse med de väsentliga kraven och andra relevanta bestämmelser i Direktiv 1999/5/EC.

### Assessment Criteria

The following standards were applied during the assessment of the product against the requirements of the Directive 1999/5/EC:

- Radio: EN 301 893 and EN 300 328 (if applicable)
- EMC: EN 301 489-1 and EN 301 489-17
- Safety: EN 50371 to EN 50385 and EN 60601

### CE Marking

For the Xirrus Wireless AP, the CE mark and Class-2 identifier opposite are affixed to the equipment and its packaging:



### Russian Certification Marking

For the Xirrus XR-500, XR-520H, XR-2000, and XR-4000 Series Wireless APs, the approval mark is affixed to the equipment:



## WEEE Compliance



- Natural resources were used in the production of this equipment.
- This equipment may contain hazardous substances that could impact the health of the environment.
- In order to avoid harm to the environment and consumption of natural resources, we encourage you to use appropriate take-back systems when disposing of this equipment.
- The appropriate take-back systems will reuse or recycle most of the materials of this equipment in a way that will not harm the environment.
- The crossed-out wheeled bin symbol (in accordance with European Standard EN 50419) invites you to use those take-back systems and advises you not to combine the material with refuse destined for a land fill.
- If you need more information on collection, re-use and recycling systems, please contact your local or regional waste administration.
- Please contact Xirrus for specific information on the environmental performance of our products.

## National Restrictions

In the majority of the EU and other European countries, the 2.4 GHz and 5 GHz bands have been made available for the use of Wireless LANs. The following table provides an overview of the regulatory requirements in general that are applicable for the 2.4 GHz and 5 GHz bands.

Frequency Band (MHz)	Max Power Level (EIRP) (mW)	Indoor	Outdoor
2400–2483.5	100	X	X **
5250–5350 *	200	X	N/A
5470–5725*	1000	X	X

*\*Dynamic frequency selection and Transmit Power Control is required in these frequency bands.*

*\*\*France is indoor use only in the upper end of the band.*

The requirements for any country may change at any time. Xirrus recommends that you check with local authorities for the current status of their national regulations for both 2.4 GHz and 5 GHz wireless LANs.

The following countries have additional requirements or restrictions than those listed in the above table:

### Belgium

The Belgian Institute for Postal Services and Telecommunications (BIPT) must be notified of any outdoor wireless link having a range exceeding 300 meters. Xirrus recommends checking at [www.bipt.be](http://www.bipt.be) for more details.

*Draadloze verbindingen voor buitengebruik en met een reikwijdte van meer dan 300 meter dienen aangemeld te worden bij het Belgisch Instituut voor postdiensten en telecommunicatie (BIPT). Zie [www.bipt.be](http://www.bipt.be) voor meer gegevens.*

*Les liaisons sans fil pour une utilisation en extérieur d'une distance supérieure à 300 mètres doivent être notifiées à l'Institut Belge des services Postaux et des Télécommunications (IBPT). Visitez [www.bipt.be](http://www.bipt.be) pour de plus amples détails.*

### Greece

A license from EETT is required for the outdoor operation in the 5470 MHz to 5725 MHz band. Xirrus recommends checking [www.eett.gr](http://www.eett.gr) for more details.

*Η δη ιουργβάικτ ωνεξωτερικο ρουστη ζ νησυ νοτ των 5470–5725 MHz ε ιτρ ετάιωνο ετάά όάδειά της EETT, ου ορηγεβτάι στερά ά ό σ φωνη γν η του ΓΕΕΘΑ. ερισσότερες λε τομ ρειεωστο [www.eett.gr](http://www.eett.gr)*

### Italy

This product meets the National Radio Interface and the requirements specified in the National Frequency Allocation Table for Italy. Unless this wireless LAN product is operating within the boundaries of the owner's property, its use requires a "general authorization." Please check with [www.comunicazioni.it/it/](http://www.comunicazioni.it/it/) for more details.

*Questo prodotto é conforme alla specifiche di Interfaccia Radio Nazionali e rispetta il Piano Nazionale di ripartizione delle frequenze in Italia. Se non viene installato all'interno del proprio fondo, l'utilizzo di prodotti wireless LAN richiede una "autorizzazione Generale." Consultare [www.comunicazioni.it/it/](http://www.comunicazioni.it/it/) per maggiori dettagli.*

### Norway, Switzerland and Liechtenstein

Although Norway, Switzerland and Liechtenstein are not EU member states, the EU Directive 1999/5/EC has also been implemented in those countries.

## Calculating the Maximum Output Power

The regulatory limits for maximum output power are specified in EIRP (radiated power). The EIRP level of a device can be calculated by adding the gain of the antenna used (specified in dBi) to the output power available at the connector (specified in dBm).

## Antennas

The Xirrus Wireless AP employs integrated antennas that cannot be removed and which are not user accessible. Nevertheless, as regulatory limits are not the same throughout the EU, users may need to adjust the conducted power setting for the radio to meet the EIRP limits applicable in their country or region. Adjustments can be made from the product's management interface—either Web Management Interface (WMI) or Command Line Interface (CLI).

## Operating Frequency

The operating frequency in a wireless LAN is determined by the access point. As such, it is important that the access point is correctly configured to meet the local regulations. See [National Restrictions](#) in this section for more information.

If you still have questions regarding the compliance of Xirrus products or you cannot find the information you are looking for, please contact us at:

Xirrus, Inc.  
2101 Corporate Center Drive  
Thousand Oaks, CA 91320  
USA  
Tel: 1.805.262.1600  
1.800.947.7871 Toll Free in the US  
Fax: 1.866.462.3980

[www.xirrus.com](http://www.xirrus.com)



## Compliance Information (Non-EU)



*This Appendix contains Notices, Warnings, and Compliance information for the XD and XR500/600 Series only. For other models, see the notes under “Notices (XR-1000 to XR-6000 Indoor Models)” on page 563.*

This section contains compliance information for the Xirrus Wireless AP family of products. The compliance information contained in this section is relevant to the listed countries (outside of the European Union and other countries that have implemented the EU Directive 1999/5/EC).

### Declaration of Conformity—Brazil

#### XR-500



## Declaration of Conformity

**Mexico** XR-520: Dictamen #: 1402D00742  
XR-600: Dictamen #: 1402CE08098

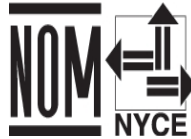

XR-520: Cofetel Cert #: RCPXIXR13-1003

**Thailand** This telecommunication equipment conforms to NTC technical requirement.

## Safety Warnings



*This Appendix contains Notices, Warnings, and Compliance information for the XD and XR500/600 Series only. For other models, see the notes under “Notices (XR-1000 to XR-6000 Indoor Models)” on page 563.*



### Safety Warnings

- Read all user documentation before powering this device. All Xirrus interconnected equipment should be contained indoors. This product is not suitable for outdoor operation. Please verify the integrity of the system ground prior to installing Xirrus equipment. Additionally, verify that the ambient operating temperature does not exceed 50°C (40°C for the XR500/600 Series).



### Explosive Device Proximity Warning

- Do not operate the XR Series Wireless AP near unshielded blasting caps or in an explosive environment unless the device has been modified to be especially qualified for such use.



### Lightning Activity Warning

- Do not work on the XR Series Wireless AP or connect or disconnect cables during periods of lightning activity.



### Circuit Breaker Warning

- The XR Series Wireless AP relies on the building’s installation for over current protection. Ensure that a fuse or circuit breaker no larger than 120 VAC, 15A (U.S.) or 240 VAC, 10A (International) is used on all current-carrying conductors.

Translated safety warnings appear on the following page.

---

## Translated Safety Warnings



*This Appendix contains Notices, Warnings, and Compliance information for the XD and XR500/600 Series only. For other models, see the notes under "Notices (XR-1000 to XR-6000 Indoor Models)" on page 563.*

### Avertissements de Sécurité



#### Sécurité

Lisez l'ensemble de la documentation utilisateur avant de mettre cet appareil sous tension. Tous les équipements Xirrus interconnectés doivent être installés en intérieur. Ce produit n'est pas conçu pour être utilisé en extérieur. Veuillez vérifier l'intégrité de la terre du système avant d'installer des équipements Xirrus. Vérifiez également que la température de fonctionnement ambiante n'excède pas 50°C (40°C pour XR-520).



#### Proximité d'appareils explosifs

N'utilisez pas l'unité XR Wireless AP à proximité d'amorces non blindées ou dans un environnement explosif, à moins que l'appareil n'ait été spécifiquement modifié pour un tel usage.



#### Foudre

N'utilisez pas l'unité XR Wireless AP et ne branchez pas ou ne débranchez pas de câbles en cas de foudre.



#### Disjoncteur

L'unité XR Wireless AP dépend de l'installation du bâtiment pour ce qui est de la protection contre les surintensités. Assurez-vous qu'un fusible ou qu'un disjoncteur de 120 Vca, 15 A (États-Unis) ou de 240 Vca, 10 A (International) maximum est utilisé sur tous les conducteurs de courant.

## Software License and Product Warranty Agreement

THIS SOFTWARE LICENSE AGREEMENT (THE “AGREEMENT”) IS A LEGAL AGREEMENT BETWEEN YOU (“CUSTOMER”) AND LICENSOR (AS DEFINED BELOW) AND GOVERNS THE USE OF THE SOFTWARE INSTALLED ON THE PRODUCT (AS DEFINED BELOW). IF YOU ARE AN EMPLOYEE OR AGENT OF CUSTOMER, YOU HEREBY REPRESENT AND WARRANT TO LICENSOR THAT YOU HAVE THE POWER AND AUTHORITY TO ACCEPT AND TO BIND CUSTOMER TO THE TERMS AND CONDITIONS OF THIS AGREEMENT (INCLUDING ANY THIRD PARTY TERMS SET FORTH HEREIN). IF YOU DO NOT AGREE TO ALL OF THE TERMS OF THIS AGREEMENT RETURN THE PRODUCT AND ALL ACCOMPANYING MATERIALS (INCLUDING ALL DOCUMENTATION) TO THE RELEVANT VENDOR FOR A FULL REFUND OF THE PURCHASE PRICE THEREFORE.

CUSTOMER UNDERSTANDS AND AGREES THAT USE OF THE PRODUCT AND SOFTWARE SHALL BE DEEMED AN AGREEMENT TO THE TERMS AND CONDITIONS GOVERNING SUCH SOFTWARE AND THAT CUSTOMER IS BOUND BY AND BECOMES A PARTY TO THIS AGREEMENT.

### 1.0 DEFINITIONS

- 1.1 “Documentation” means the user manuals and all other all documentation, instructions or other similar materials accompanying the Software covering the installation, application, and use thereof.
- 1.2 “Licensor” means Xirrus and its suppliers.
- 1.3 “Product” means a multi-radio access point containing four or more distinct radios capable of simultaneous operation on four or more non-overlapping channels.
- 1.4 “Software” means, collectively, each of the application and embedded software programs delivered to Customer in connection with this Agreement. For purposes of this Agreement, the term Software shall be deemed to include any and all Documentation and Updates provided with or for the Software.
- 1.5 “Updates” means any bug-fix, maintenance or version release to the Software that may be provided to Customer from Licensor pursuant to this Agreement or pursuant to any separate maintenance and support agreement entered into by and between Licensor and Customer.

### 2.0 GRANT OF RIGHTS

- 2.1 Software. Subject to the terms and conditions of this Agreement, Licensor hereby grants to Customer a perpetual, non-exclusive, non-sublicenseable, non-transferable right and license to use the Software solely as installed on

the Product in accordance with the accompanying Documentation and for no other purpose.

- 2.2 Ownership. The license granted under Sections 2.1 above with respect to the Software does not constitute a transfer or sale of Licensor's or its suppliers' ownership interest in or to the Software, which is solely licensed to Customer. The Software is protected by both national and international intellectual property laws and treaties. Except for the express licenses granted to the Software, Licensor and its suppliers retain all rights, title and interest in and to the Software, including (i) any and all trade secrets, copyrights, patents and other proprietary rights therein or thereto or (ii) any Marks (as defined in Section 2.3 below) used in connection therewith. In no event shall Customer remove, efface or otherwise obscure any Marks contained on or in the Software. All rights not expressly granted herein are reserved by Licensor.
- 2.3 Copies. Customer shall not make any copies of the Software but shall be permitted to make a reasonable number of copies of the related Documentation. Whenever Customer copies or reproduces all or any part of the Documentation, Customer shall reproduce all and not efface any titles, trademark symbols, copyright symbols and legends, and other proprietary markings or similar indicia of origin ("Marks") on or in the Documentation.
- 2.4 Restrictions. Customer shall not itself, or through any parent, subsidiary, affiliate, agent or other third party (i) sell, rent, lease, license or sublicense, assign or otherwise transfer the Software, or any of Customer's rights and obligations under this Agreement except as expressly permitted herein; (ii) decompile, disassemble, or reverse engineer the Software, in whole or in part, provided that in those jurisdictions in which a total prohibition on any reverse engineering is prohibited as a matter of law and such prohibition is not cured by the fact that this Agreement is subject to the laws of the State of California, Licensor agrees to grant Customer, upon Customer's written request to Licensor, a limited reverse engineering license to permit interoperability of the Software with other software or code used by Customer; (iii) allow access to the Software by any user other than by Customer's employees and contractors who are bound in writing to confidentiality and non-use restrictions at least as protective as those set forth herein; (iv) except as expressly set forth herein, write or develop any derivative software or any other software program based upon the Software; (v) use any computer software or hardware which is designated to defeat any copy protection or other use limiting device, including any device intended to limit the number of users or devices accessing the Product; (vi) disclose information about the performance or operation of the Product or Software to any third party without the prior written consent of Licensor; or (vii) engage a third party to perform benchmark or functionality testing of the Product or Software.

### **3.0 LIMITED WARRANTY AND LIMITATION OF LIABILITY**

- 3.1 Limited Warranty & Exclusions. Licensor warrants that the Software will perform in substantial accordance with the specifications therefore set forth in the Documentation for a period of ninety [90] days after Customer's acceptance of the terms of this Agreement with respect to the Software ("Warranty Period"). If during the Warranty Period the Software or Product does not perform as warranted, Licensor shall, at its option, correct the relevant Product and/or Software giving rise to such breach of performance or replace such Product and/or Software free of charge. THE FOREGOING ARE CUSTOMER'S SOLE AND EXCLUSIVE REMEDIES FOR BREACH OF THE FOREGOING WARRANTY. THE WARRANTY SET FORTH ABOVE IS MADE TO AND FOR THE BENEFIT OF CUSTOMER ONLY. The warranty will apply only if (i) the Software has been used at all times and in accordance with the instructions for use set forth in the Documentation and this Agreement; (ii) no modification, alteration or addition has been made to the Software by persons other than Licensor or Licensor's authorized representative; and (iii) the Software or Product on which the Software is installed has not been subject to any unusual electrical charge.
- 3.2 DISCLAIMER. EXCEPT AS EXPRESSLY STATED IN THIS SECTION 3, ALL ADDITIONAL CONDITIONS, REPRESENTATIONS, AND WARRANTIES, WHETHER IMPLIED, STATUTORY OR OTHERWISE, INCLUDING, WITHOUT LIMITATION, ANY IMPLIED WARRANTIES OR CONDITIONS OF MERCHANTABILITY, FITNESS FOR A PARTICULAR PURPOSE, SATISFACTORY QUALITY, ACCURACY, AGAINST INFRINGEMENT OR ARISING FROM A COURSE OF DEALING, USAGE, OR TRADE PRACTICE, ARE HEREBY DISCLAIMED BY LICENSOR AND ITS SUPPLIERS. THIS DISCLAIMER SHALL APPLY EVEN IF ANY EXPRESS WARRANTY AND LIMITED REMEDY OFFERED BY LICENSOR FAILS OF ITS ESSENTIAL PURPOSE. ALL WARRANTIES PROVIDED BY LICENSOR ARE SUBJECT TO THE LIMITATIONS OF LIABILITY SET FORTH IN THIS AGREEMENT.
- 3.3 HAZARDOUS APPLICATIONS. THE SOFTWARE IS NOT DESIGNED OR INTENDED FOR USE IN HAZARDOUS ENVIRONMENTS REQUIRING FAIL SAFE PERFORMANCE, SUCH AS IN THE OPERATION OF A NUCLEAR FACILITY, AIRCRAFT NAVIGATION OR COMMUNICATIONS SYSTEMS, AIR TRAFFIC CONTROLS OR OTHER DEVICES OR SYSTEMS IN WHICH A MALFUNCTION OF THE SOFTWARE WOULD RESULT IN FORSEEABLE RISK OF INJURY OR DEATH TO THE OPERATOR OF THE DEVICE OR SYSTEM OR TO OTHERS ("HAZARDOUS APPLICATIONS"). CUSTOMER ASSUMES ANY AND ALL RISKS, INJURIES, LOSSES, CLAIMS AND ANY OTHER LIABILITIES ARISING OUT OF THE USE OF THE SOFTWARE IN ANY HAZARDOUS APPLICATIONS.

### 3.4 Limitation of Liability.

- (a) TOTAL LIABILITY. NOTWITHSTANDING ANYTHING ELSE HEREIN, ALL LIABILITY OF LICENSOR AND ITS SUPPLIERS UNDER THIS AGREEMENT SHALL BE LIMITED TO THE AMOUNT PAID BY CUSTOMER FOR THE RELEVANT SOFTWARE, OR PORTION THEREOF, THAT GAVE RISE TO SUCH LIABILITY OR ONE HUNDRED UNITED STATES DOLLARS (US\$100), WHICHEVER IS GREATER. THE LIABILITY OF LICENSOR AND ITS SUPPLIERS UNDER THIS SECTION SHALL BE CUMULATIVE AND NOT PER INCIDENT.
- (b) DAMAGES. IN NO EVENT SHALL LICENSOR, ITS SUPPLIERS OR THEIR RELEVANT SUBCONTRACTORS BE LIABLE FOR (A) ANY INCIDENTAL, SPECIAL, PUNITIVE OR CONSEQUENTIAL DAMAGES, LOST PROFITS OR LOST OR DAMAGED DATA, OR ANY INDIRECT DAMAGES, WHETHER ARISING IN CONTRACT, TORT (INCLUDING NEGLIGENCE AND STRICT LIABILITY) OR OTHERWISE OR (B) ANY COSTS OR EXPENSES FOR THE PROCUREMENT OF SUBSTITUTE GOODS OR SERVICES IN EACH CASE, EVEN IF LICENSOR OR ITS SUPPLIERS HAVE BEEN INFORMED OF THE POSSIBILITY OF SUCH DAMAGES.

3.5 Exclusions. SOME JURISDICTIONS DO NOT PERMIT THE LIMITATIONS OF LIABILITY AND LIMITED WARRANTIES SET FORTH UNDER THIS AGREEMENT. IN THE EVENT YOU ARE LOCATED IN ANY SUCH JURISDICTION, THE FOREGOING LIMITATIONS SHALL APPLY ONLY TO THE MAXIMUM EXTENT PERMITTED IN SUCH JURISDICTIONS. IN NO EVENT SHALL THE FOREGOING EXCLUSIONS AND LIMITATIONS ON DAMAGES BE DEEMED TO APPLY TO ANY LIABILITY BASED ON FRAUD, WILLFUL MISCONDUCT, GROSS NEGLIGENCE OR PERSONAL INJURY OR DEATH.

## 4.0 CONFIDENTIAL INFORMATION

4.1 Generally. The Software (and its accompanying Documentation) constitutes Licensor's and its suppliers' proprietary and confidential information and contains valuable trade secrets of Licensor and its suppliers ("Confidential Information"). Customer shall protect the secrecy of the Confidential Information to the same extent it protects its other valuable, proprietary and confidential information of a similar nature but in no event shall Customer use less than reasonable care to maintain the secrecy of the Confidential Information. Customer shall not use the Confidential Information except to exercise its rights or perform its obligations as set forth under this Agreement. Customer shall not disclose such Confidential Information to any third party other than subject to non-use and non-disclosure obligations at least as



protective of a party's right in such Confidential Information as those set forth herein.

- 4.2 Return of Materials. Customer agrees to (i) destroy all Confidential Information (including deleting any and all copies contained on any of Customer's Designated Hardware or the Product) within fifteen (15) days of the date of termination of this Agreement or (ii) if requested by Licensor, return, any Confidential Information to Licensor within thirty (30) days of Licensor's written request.

## 5.0 TERM AND TERMINATION

5.1 Term. Subject to Section 5.2 below, this Agreement will take effect on the Effective Date and will remain in force until terminated in accordance with this Agreement.

5.2 Termination Events. This Agreement may be terminated immediately upon written notice by either party under any of the following conditions:

- (a) If the other party has failed to cure a breach of any material term or condition under the Agreement within thirty (30) days after receipt of notice from the other party; or
- (b) Either party ceases to carry on business as a going concern, either party becomes the object of the institution of voluntary or involuntary proceedings in bankruptcy or liquidation, which proceeding is not dismissed within ninety (90) days, or a receiver is appointed with respect to a substantial part of its assets.

5.3 Effect of Termination.

- (a) Upon termination of this Agreement, in whole or in part, Customer shall pay Licensor for all amounts owed up to the effective date of termination. Termination of this Agreement shall not constitute a waiver for any amounts due.
- (b) The following Sections shall survive the termination of this Agreement for any reason: Sections 1, 2.2, 2.4, 3, 4, 5.3, and 6.
- (c) No later than thirty (30) days after the date of termination of this Agreement by Licensor, Customer shall upon Licensor's instructions either return the Software and all copies thereof; all Documentation relating thereto in its possession that is in tangible form or destroy the same (including any copies thereof contained on Customer's Designated Hardware). Customer shall furnish Licensor with a certificate signed by an executive officer of Customer verifying that the same has been done.

## 6. MISCELLANEOUS

If Customer is a corporation, partnership or similar entity, then the license to the Software and Documentation that is granted under this Agreement is expressly conditioned upon and Customer represents and warrants to Licensor that the person accepting the terms of this Agreement is authorized to bind such entity to the terms and conditions herein. If any provision of this Agreement is held to be invalid or unenforceable, it will be enforced to the extent permissible and the remainder of this Agreement will remain in full force and effect. During the course of use of the Software, Licensor may collect information on your use thereof; you hereby authorize Licensor to use such information to improve its products and services, and to disclose the same to third parties provided it does not contain any personally identifiable information. The express waiver by either party of any provision, condition or requirement of this Agreement does not constitute a waiver of any future obligation to comply with such provision, condition or requirement. Customer and Licensor are independent parties. Customer may not export or re-export the Software or Documentation (or other materials) without appropriate United States, European Union and foreign government licenses or in violation of the United State's Export Administration Act or foreign equivalents and Customer shall comply with all national and international laws governing the Software. This Agreement will be governed by and construed under the laws of the State of California and the United States as applied to agreements entered into and to be performed entirely within California, without regard to conflicts of laws provisions thereof and the parties expressly exclude the application of the United Nations Convention on Contracts for the International Sales of Goods and the Uniform Computer Information Transactions Act (as promulgated by any State) to this Agreement. Suits or enforcement actions must be brought within, and each party irrevocably commits to the exclusive jurisdiction of, the state and federal courts located in Ventura County, California. Customer may not assign this Agreement by operation of law or otherwise, without the prior written consent of Licensor and any attempted assignment in violation of the foregoing shall be null and void. This Agreement cancels and supersedes all prior agreements between the parties. This Agreement may not be varied except through a document agreed to and signed by both parties. Any printed terms and conditions contained in any Customer purchase order or in any Licensor acknowledgment, invoice or other documentation relating to the Software shall be deemed deleted and of no force or effect and any additional typed and/or written terms and conditions contained shall be for administrative purposes only, i.e. to identify the types and quantities of Software to be supplied, line item prices and total price, delivery schedule, and other similar ordering data, all in accordance with the provisions of this Agreement.

## Hardware Warranty Agreement

PLEASE READ THIS AGREEMENT CAREFULLY BEFORE USING THIS PRODUCT

BY USING THIS PRODUCT, YOU ACKNOWLEDGE THAT YOU HAVE READ AND UNDERSTOOD ALL THE TERMS AND CONDITIONS OF THIS AGREEMENT AND THAT YOU ARE CONSENTING TO BE BOUND BY THIS AGREEMENT. IF YOU DO NOT AGREE TO ALL OF THE TERMS OF THIS AGREEMENT, RETURN THE UNUSED PRODUCT TO THE PLACE OF PURCHASE FOR A FULL REFUND.

LIMITED WARRANTY. Xirrus warrants that for a period of five years from the date of purchase by the original purchaser ("Customer"): (i) the Xirrus Equipment ("Equipment") will be free of defects in materials and workmanship under normal use; and (ii) the Equipment substantially conforms to its published specifications. Except for the foregoing, the Equipment is provided AS IS. This limited warranty extends only to Customer as the original purchaser. Customer's exclusive remedy and the entire liability of Xirrus and its suppliers under this limited warranty will be, at Xirrus' option, repair, replacement, or refund of the Equipment if reported (or, upon request, returned) to the party supplying the Equipment to Customer. In no event does Xirrus warrant that the Equipment is error free or that Customer will be able to operate the Equipment without problems or interruptions.

This warranty does not apply if the Equipment (a) has been altered, except by Xirrus, (b) has not been installed, operated, repaired, or maintained in accordance with instructions supplied by Xirrus, (c) has been subjected to abnormal physical or electrical stress, misuse, negligence, or accident, or (d) is used in ultra-hazardous activities.

DISCLAIMER. EXCEPT AS SPECIFIED IN THIS WARRANTY, ALL EXPRESS OR IMPLIED CONDITIONS, REPRESENTATIONS, AND WARRANTIES INCLUDING, WITHOUT LIMITATION, ANY IMPLIED WARRANTY OF MERCHANTABILITY, FITNESS FOR A PARTICULAR PURPOSE, NONINFRINGEMENT OR ARISING FROM A COURSE OF DEALING, USAGE, OR TRADE PRACTICE, ARE HEREBY EXCLUDED TO THE EXTENT ALLOWED BY APPLICABLE LAW.

IN NO EVENT WILL XIRRUS OR ITS SUPPLIERS BE LIABLE FOR ANY LOST REVENUE, PROFIT, OR DATA, OR FOR SPECIAL, INDIRECT, CONSEQUENTIAL, INCIDENTAL, OR PUNITIVE DAMAGES HOWEVER CAUSED AND REGARDLESS OF THE THEORY OF LIABILITY ARISING OUT OF THE USE OF OR INABILITY TO USE THE EQUIPMENT EVEN IF XIRRUS OR ITS SUPPLIERS HAVE BEEN ADVISED OF THE POSSIBILITY OF SUCH DAMAGES. In no event shall Xirrus' or its suppliers' liability to Customer,

whether in contract, tort (including negligence), or otherwise, exceed the price paid by Customer.

The foregoing limitations shall apply even if the above-stated warranty fails of its essential purpose. SOME STATES DO NOT ALLOW LIMITATION OR EXCLUSION OF LIABILITY FOR CONSEQUENTIAL OR INCIDENTAL DAMAGES.

The above warranty DOES NOT apply to any evaluation Equipment made available for testing or demonstration purposes. All such Equipment is provided AS IS without any warranty whatsoever.

Customer agrees the Equipment and related documentation shall not be used in life support systems, human implantation, nuclear facilities or systems or any other application where failure could lead to a loss of life or catastrophic property damage, or cause or permit any third party to do any of the foregoing.

All information or feedback provided by Customer to Xirrus with respect to the Product shall be Xirrus' property and deemed confidential information of Xirrus.

Equipment including technical data, is subject to U.S. export control laws, including the U.S. Export Administration Act and its associated regulations, and may be subject to export or import regulations in other countries. Customer agrees to comply strictly with all such regulations and acknowledges that it has the responsibility to obtain licenses to export, re-export, or import Equipment.

This Agreement shall be governed by and construed in accordance with the laws of the State of California, United States of America, as if performed wholly within the state and without giving effect to the principles of conflict of law. If any portion hereof is found to be void or unenforceable, the remaining provisions of this Warranty shall remain in full force and effect. This Warranty constitutes the entire agreement between the parties with respect to the use of the Equipment.

Manufacturer is Xirrus, Inc. 2101 Corporate Center Drive Thousand Oaks, CA 91320