

azur

650R

 **Cambridge Audio**

Your music + our passion

Make sure you register your purchase.

Visit: www.cambridge-audio.com/sts

By registering, you'll be the first to know about:

- Future product releases
- Software upgrades
- News, events and exclusive offers plus competitions!

-This guide is designed to make installing and using this product as easy as possible. Information in this document has been carefully checked for accuracy at the time of printing; however, Cambridge Audio's policy is one of continuous improvement, therefore design and specifications are subject to change without prior notice.

This document contains proprietary information protected by copyright. All rights are reserved. No part of this manual may be reproduced by any mechanical, electronic or other means, in any form, without prior written permission of the manufacturer. All trademarks and registered trademarks are the property of their respective owners.

Incognito and Incognito Ready are trademarks of Cambridge Audio Ltd. All rights reserved.

© Copyright Cambridge Audio Ltd 2010

Manufactured under license from Dolby Laboratories. "Dolby" and the double-D symbol are trademarks of Dolby Laboratories.

Manufactured under license under U.S. Patent #'s: 5,451,942; 5,956,674; 5,974,380; 5,978,762; 6,226,616; 6,487,535; 7,212,872; 7,333,929; 7,392,195; 7,272,567 & other U.S. and worldwide patents issued & pending. DTS is a registered trademark and the DTS logos, Symbol, DTS-HD and DTS-HD Master Audio are trademarks of DTS, Inc. © 1996-2009 DTS, Inc. All Rights Reserved.

"HDMI", "HDMI logo" and "High-Definition Multimedia Interface" are trademarks or registered trademarks of HDMI Licensing LLC.

A-BUS and A-BUS Ready are registered trademarks of LeisureTech Electronics Pty Ltd Australia.

Contents

Introduction	3
Before connecting	3
Limited warranty	4
Important safety instructions	4
Front panel controls	6
Rear panel connections	7
Remote control	8
Front panel display	9
Loudspeaker connections	9
Analogue audio connections	10
Digital audio connections	10
HDMI input connections	11
Analogue video input connections	11
Video output connections	12
5.1/6.1/7.1 Direct In	12
7.1 Preamp Out	13
Front input connections	13
Aerial connections	13
650R setup	14
1. Speaker configuration	14
2. Speaker setup	15
Speaker delay	15
Level calibration	16
Auto Speaker setup	16
3. Assigning any HDMI (or DVI) sources	17
4. Source setup	17
Video connection type	18
Surround Sound modes	18
Operating instructions	20
Decode modes	21-23
Dynamic range control	24
Advanced Dolby/DTS adjustments	24
DTS-HD speaker re-map	24
Using the Tuner	26
Audio split mode	26
Recorder 1/2	26
Sub crossovers and bass management	26
Bi-amping	27
Tone/Sub/LFE configuration	27
Lip sync	28
Input naming	28
OSD setup	28
Custom installation (C.I.) use	28
Reset/Back-up memory	28
Multi-room connections	29
Troubleshooting	30
Technical Specifications	31

Introduction

Thank you for purchasing this Cambridge Audio Azur range AV receiver. Like all Cambridge Audio products, the 650R adheres to three core principles – stunning performance, ease of use and incredible value.

As such, the seven 100W audiophile grade fully discrete amplifiers are kept as separate as possible from the processing and input stages and feature a large power supply with a low flux toroidal transformer. This careful design of the amplifier stages ensure that the 650R can reproduce the dynamics and scale required for modern movie soundtracks whilst also being able to reproduce a genuinely musical performance with either stereo or multi-channel music sources.

A full range of HDMI, digital and analogue inputs are fitted. These allow the connection of suitably equipped Blu-ray players, DVD players, satellite/set-top boxes and games consoles for decoding into stereo, stereo + sub or various digital surround formats. The latest formats are supported including Dolby True HD, Dolby Digital Plus, DTS-HD Master Audio, DTS-HD High Resolution Audio, Dolby Digital 5.1 and EX, DTS 5.1 and ES in 5.1, 6.1 or 7.1 variants. In particular support for the true lossless Dolby True HD and DTS-HD Master Audio formats provides unprecedented audio fidelity from Blu-ray discs. The 650R is also capable of decoding encoded analogue or digital stereo sources in Dolby Pro Logic® II or IIx and DTS Neo:6, again in 5.1, 6.1 or 7.1 variants for a convincing and effective surround experience from a matrix encoded stereo source. Sophisticated post-processing of 5.1 or 6.1 digital material is also possible with PLIIx or DTS Neo:6 to turn these formats into 6.1 or 7.1.

Conventional analogue stereo inputs allow the connection of audiophile CD players and the like, and an Analogue Stereo Direct mode ensures the very best possible stereo reproduction for these.

The 650R also carries a 5.1 / 6.1 / 7.1 channel analogue input. This feature allows for the connection of a DVD Audio or SACD player equipped with a 5.1 output and is compatible with future external 6.1/7.1 audio formats.

As well as the full complement of audio inputs, the 650R also performs Composite, S-Video, Component Video and HDMI input switching and transcoding. The unit features full On-Screen Display (OSD) on all video outputs. Transcoding allows composite video, S-Video and Component video to be up converted to HDMI for a simpler interface to the TV/Monitor.

Multi-Room compatibility is featured in the form of A-BUS Ready™/Incognito Ready™ outputs for either Cambridge Audio Incognito keypads (and power supply) or other manufacturers products compatible with the A-BUS standard. This allows a 2 or 3 zone multi-room system to be easily constructed, second and third zone video outputs mean the remote rooms can even have video capability.

An RS232 port, IR Emitter In and Control Bus In/Out also make it easy to integrate the 650R into a Custom Install situation.

All this proprietary engineering is housed within our low resonance, acoustically damped chassis. An Azur Navigator remote control is also provided, giving full remote control of your AV receiver in an attractive and easy to use handset.

Remember your 650R can only be as good as the system it is connected to. Please do not compromise on your source equipment, speaker package or video and audio cabling. Naturally we particularly recommend Blu-ray, DVD and CD players or other source equipment from the Cambridge Audio Azur range, which have been designed to the same exacting standards as our receivers. Your dealer can also supply excellent quality Cambridge Audio interconnects to ensure your system realises its full potential.

Thanks for taking the time to read this manual, we do recommend you keep it for future reference.



Matthew Bramble
Cambridge Audio Technical Director and the 650R design team

Before connecting

The process of setting up the 650R is first to make all the connections to your speakers and source equipment and then set the unit up via its On-Screen Display (OSD), as there are various settings and adjustments that need to be made before the 650R can be used.

However before you actually decide which connections to make or perform any adjustments it is strongly advised that you read through the '650R setup' section of this manual first, starting on page 14.

A lot of explanation is included that will help you to choose the right connection types for both your sources and TV.

Important safety instructions

For your own safety please read the following important safety instructions carefully before attempting to connect this unit to the mains power supply. They will also enable you to get the best performance from and prolong the life of the unit:

1. Read these instructions.
2. Keep these instructions.
3. Heed all warnings.
4. Follow all instructions.
5. Do not use this apparatus near water.
6. Clean only with a dry cloth.
7. Do not block any ventilation openings. Install in accordance with the manufacturer's instructions.
8. Do not install near any heat sources such as radiators, heat registers, stoves, or other apparatus (including amplifiers) that produce heat.
9. Do not defeat the safety purpose of the polarized or grounding-type plug. A polarized plug has two blades with one wider than the other. A grounding-type plug has two blades and a third grounding prong. The wide blade or the third prong are provided for your safety. If the provided plug does not fit into your outlet, consult an electrician for replacement of the obsolete outlet.
10. Protect the power cord from being walked on or pinched, particularly at plugs, convenience receptacles and the point where they exit from the apparatus.
11. Only use attachments/accessories specified by the manufacturer.
12. Use with only the cart, stand, tripod, bracket, or table specified by the manufacturer, or sold with the apparatus. When a cart is used, use caution when moving the cart/apparatus combination to avoid injury from tip-over. 
13. Unplug this apparatus during lightning storms or when unused for long periods of time.
14. Refer all servicing to qualified service personnel. Servicing is required when the apparatus has been damaged in any way, such as the power-supply cord or plug having been damaged, liquid has been spilled or objects have fallen into the apparatus, the apparatus has been exposed to rain or moisture, does not operate normally, or has been dropped.

WARNING

- To reduce the risk of fire or electric shock, do not expose this unit to rain or moisture.
- Batteries (battery pack or batteries installed) shall not be exposed to excessive heat such as sunshine, fire or the like.

The unit must be installed in a manner that makes disconnection of the mains plug from the mains socket outlet (or appliance connector from the rear of the unit) possible. Where the mains plug is used as the disconnect device, the disconnect device shall remain readily operable. Only use the mains cord supplied with this unit.

Please ensure there is ample ventilation (at least 10cm clearance all round). Do not put any objects on top of this unit. Do not situate it on a rug or other soft surface and do not obstruct any air inlets or outlet grilles. Do not cover the ventilation grilles with items such as newspapers, tablecloths, curtains, etc.

This unit must not be used near water or exposed to dripping or splashing water or other liquids. No objects filled with liquid, such as vases, shall be placed on the unit.



The lightning flash with the arrowhead symbol within an equilateral triangle is intended to alert the user to the presence of un-insulated 'dangerous voltage' within the product's enclosure that may be of sufficient magnitude to constitute a risk of electric shock to persons.

The exclamation point within an equilateral triangle is intended to alert the user to the presence of important operating and maintenance instructions in the service literature relevant to this appliance.



The symbol on this product indicates that it is of CLASS II (double insulated) construction.



WEEE symbol

The crossed-out wheeled bin is the European Union symbol for indicating separate collection for electrical and electronic equipment. This product contains electrical and electronic equipment which should be reused, recycled or recovered and should not be disposed of with unsorted regular waste. Please return the unit or contact the authorised dealer from whom you purchased this product for more information.



CE mark

This product complies with European Low Voltage (2006/95/EC), Electromagnetic Compatibility (2004/108/EC) and Environmentally-friendly design of Energy-related Products (2009/125/EC) Directives when used and installed according to this instruction manual. For continued compliance only Cambridge Audio accessories should be used with this product and servicing must be referred to qualified service personnel.



C-Tick mark

This product meets the Australian Communications Authority's Radio communications and EMC requirements.



Ross Test Stamp

This product meets Russian electronic safety approvals.

FCC regulations

NOTE: THE MANUFACTURER IS NOT RESPONSIBLE FOR ANY RADIO OR TV INTERFERENCE CAUSED BY UNAUTHORIZED MODIFICATIONS TO THIS EQUIPMENT. SUCH MODIFICATIONS COULD VOID THE USER AUTHORITY TO OPERATE THE EQUIPMENT.



This equipment has been tested and found to comply with the limits for a Class B digital device, pursuant to Part 15 of the FCC Rules. These limits are designed to provide reasonable protection against harmful interference in a residential installation. This equipment generates, uses and can radiate radio frequency energy and, if not installed and used in accordance with the instructions, may cause harmful interference to radio communications. However, there is no guarantee that interference will not occur in a particular installation.

If this equipment does cause harmful interference to radio or television reception, which can be determined by turning the equipment off and on, the user is encouraged to try to correct the interference by one or more of the following measures:

- Re-orient or relocate the receiving antenna.
- Increase the separation between the equipment and receiver.
- Connect the equipment into an outlet on a circuit different from that to which the receiver is connected.
- Consult the dealer or an experienced radio/TV technician for help.

Ventilation

IMPORTANT – The unit will become hot when in use. Do not stack multiple units on top of each other. Do not place in an enclosed area such as a bookcase or in a cabinet without sufficient ventilation.

Ensure that small objects do not fall through any ventilation grille. If this happens, switch off immediately, disconnect from the mains supply and contact your dealer for advice.

Positioning

Choose the installation location carefully. Avoid placing it in direct sunlight or close to a source of heat. No naked flame sources, such as lighted candles, should be placed on the unit. Also avoid locations subject to vibration and excessive dust, cold or moisture. The unit can be used in a moderate climate.

This unit must be installed on a sturdy, level surface. Do not place in a sealed area such as a bookcase or in a cabinet. Any space open at the back (such as a dedicated equipment rack) is fine, however. Do not place the unit on an unstable surface or shelf. The unit may fall, causing serious injury to a child or adult as well as serious damage to the product. Do not place other equipment on top of the unit.

Due to stray magnetic fields, turntables or CRT TVs should not be located nearby due to possible interference.

Electronic audio components have a running in period of around a week (if used several hours per day). This will allow the new components to settle down and the sonic properties will improve over this time.

Power sources

The unit should be operated only from the type of power source indicated on the marking label. If you are not sure of the type of power-supply to your home, consult your product dealer or local power company.

This unit has been designed to be left in Standby mode when not in use as this will increase the life of the amplifier (this is true with all electronic equipment). To turn the unit off, switch off at the rear panel. If you do not intend to use this unit for a long period of time, unplug it from the mains socket.

Overloading

Do not overload wall outlets or extension cords as this can result in a risk of fire or electric shock. Overloaded AC outlets, extension cords, frayed power cords, damaged or cracked wire insulation and broken plugs are dangerous. They may result in a shock or fire hazard.

Be sure to insert each power cord securely. To prevent hum and noise, do not bundle the interconnect leads with the power cord or speaker leads.

Cleaning

To clean the unit, wipe its case with a dry, lint-free cloth. Do not use any cleaning fluids containing alcohol, ammonia or abrasives. Do not spray an aerosol at or near the unit.

Battery disposal

Batteries may contain substances harmful to the environment. Please dispose of any discharged batteries with due consideration and in accordance with local environmental/electronic recycling guidelines.

Loudspeakers

Before making any connections to loudspeakers, make sure all power is turned off and only use suitable interconnects.

Servicing

These units are not user serviceable. Never attempt to repair, disassemble or reconstruct the unit if there seems to be a problem. A serious electric shock could result if this precautionary measure is ignored. In the event of a problem or failure, please contact your dealer.

IMPORTANT

If the unit is run at a very high level, a sensor will detect a temperature rise and show "PROTECTION OVERLOAD" on the display. The unit will then go into Standby mode. It cannot be switched on again until the temperature has fallen to a more normal level.

Limited warranty

Cambridge Audio warrants this product to be free from defects in materials and workmanship (subject to the terms set forth below). Cambridge Audio will repair or replace (at Cambridge Audio's option) this product or any defective parts in this product. Warranty periods may vary from country to country. If in doubt consult your dealer and ensure that you retain proof of purchase.

To obtain warranty service, please contact the Cambridge Audio authorised dealer from which you purchased this product. If your dealer is not equipped to perform the repair of your Cambridge Audio product, it can be returned by your dealer to Cambridge Audio or an authorised Cambridge Audio service agent. You will need to ship this product in either its original packaging or packaging affording an equal degree of protection.

Proof of purchase in the form of a bill of sale or receipted invoice, which is evidence that this product is within the warranty period, must be presented to obtain warranty service.

This Warranty is invalid if (a) the factory-applied serial number has been altered or removed from this product or (b) this product was not purchased from a Cambridge Audio authorised dealer. You may call Cambridge Audio or your local country Cambridge Audio distributor to confirm that you have an unaltered serial number and/or you purchased from a Cambridge Audio authorised dealer.

This Warranty does not cover cosmetic damage or damage due to acts of God, accident, misuse, abuse, negligence, commercial use, or modification of, or to any part of, the product. This Warranty does not cover damage due to improper operation, maintenance or installation, or attempted repair by anyone other than Cambridge Audio or a Cambridge Audio dealer, or authorised service agent which is authorised to do Cambridge Audio warranty work. Any unauthorised repairs will void this Warranty. This Warranty does not cover products sold AS IS or WITH ALL FAULTS.

REPAIRS OR REPLACEMENTS AS PROVIDED UNDER THIS WARRANTY ARE THE EXCLUSIVE REMEDY OF THE CONSUMER. CAMBRIDGE AUDIO SHALL NOT BE LIABLE FOR ANY INCIDENTAL OR CONSEQUENTIAL DAMAGES FOR BREACH OF ANY EXPRESS OR IMPLIED WARRANTY IN THIS PRODUCT. EXCEPT TO THE EXTENT PROHIBITED BY LAW, THIS WARRANTY IS EXCLUSIVE AND IN LIEU OF ALL OTHER EXPRESS AND IMPLIED WARRANTIES WHATSOEVER INCLUDING, BUT NOT LIMITED TO, THE WARRANTY OF MERCHANTABILITY AND FITNESS FOR A PRACTICAL PURPOSE.

Some countries and US states do not allow the exclusion or limitation of incidental or consequential damages or implied warranties so the above exclusions may not apply to you. This Warranty gives you specific legal rights, and you may have other statutory rights, which vary from state to state or country to country.

For any service, in or out of warranty, please contact your dealer.

Plug Fitting Instructions (UK Only)

The cord supplied with this appliance is factory fitted with a UK mains plug fitted with a 5 amp fuse inside. If it is necessary to change the fuse, it is important that a 5 amp one is used. If the plug needs to be changed because it is not suitable for your socket, or becomes damaged, it should be cut off and an appropriate plug fitted following the wiring instructions below. The plug must then be disposed of safely, as insertion into a mains socket is likely to cause an electrical hazard. Should it be necessary to fit a 3-pin BS mains plug to the power cord the wires should be fitted as shown in this diagram. The colours of the wires in the mains lead of this appliance may not correspond with the coloured markings identifying the terminals in your plug. Connect them as follows:

The wire which is coloured BLUE must be connected to the terminal which is marked with the letter 'N' or coloured BLACK.

The wire which is coloured BROWN must be connected to the terminal which is marked with the letter 'L' or coloured RED.

The wire which is coloured GREEN/YELLOW must be connected to the terminal which is marked with the letter 'E' or coloured GREEN.

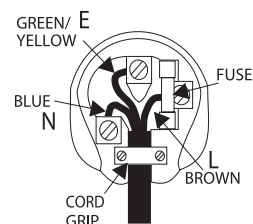

If your model does not have an earth wire, then disregard this instruction.

If a standard 13 amp (BS 1363) plug is used, a 5 amp fuse must be fitted, or if any other type of plug is used a 5 amp fuse must be fitted, either in the plug or adaptor, or on the distribution board.

Front panel controls

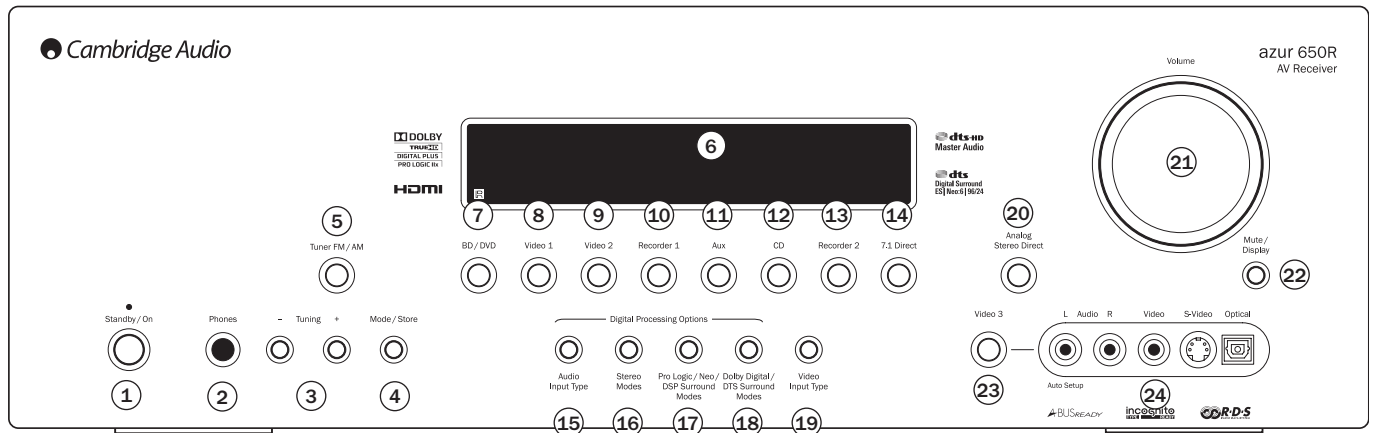

1 Standby/On

Switches the unit between Standby mode (indicated by dim power LED) and On (indicated by bright power LED). Standby is a low power mode. The unit may be left in Standby mode when not in use.

2 Phones

Allows for the connection of stereo headphones with a 6.35mm/¼" Jack plug. Headphones with an impedance of between 32 and 600 ohms are recommended.

Note: Plugging in headphones will automatically mute the main and pre-amp outputs and select a 2-channel stereo down-mix to be created for headphone use.

3 Tuning +/-

Used to tune FM frequencies and skip presets in Tuner mode.

4 Mode/Store

Press to cycle between Tuner modes and for storing presets (refer to the 'Operating Instructions' of this manual for more information).

5 Tuner FM/AM

Press to select the tuner for output through the 650R. Once in Tuner mode also use this button to switch between FM and AM modes.

6 Display

Displays the status of the unit. The IR receiver is also mounted behind this window. A clear unobstructed line of sight between the remote control and the sensor is required.

7 BD/DVD

Press to select the source equipment connected to the BD/DVD input.

8 Video 1

Press to select the source equipment connected to the Video 1 input.

9 Video 2

Press to select the source equipment connected to the Video 2 input.

10 Recorder 1

Press to select the recording device connected to the Recorder 1 input.

11 Aux

Press to select the source equipment connected to the Aux input.

12 CD

Press to select the source equipment connected to the CD input.

13 Recorder 2

Press to select the recording device connected to the Recorder 2 input.

14 7.1 Direct

Press to select a 7.1, 6.1 or 5.1 source (DVD-A or SACD player etc) connected to the 7.1 Direct In sockets.

Note: The 650R remembers the audio and video input type and processing mode for each individual source input. These are recalled each time a source is selected.

15 Audio input type

Press this button to select between analogue, digital (optical/coaxial) or HDMI input types as the source of the audio for the currently selected source input.

The choices available depend on the connections that source support on the rear panel and whether a HDMI input has been assigned to that source.

16 Stereo modes

Press to listen to a source in either digitally processed stereo or stereo and sub modes.

17 Pro Logic/Neo/DSP surround modes

Press to select between various Pro Logic II/IIx, DTS Neo:6 effects for matrix encoded analogue or digital material or for post-processing DD/DTS material (**Note:** The 650R is unable to auto-detect this kind of source material as it does not include embedded encoding type flags so manual selection is required). Also selects various DSP created surround sound modes for unencoded stereo sources.

18 Dolby Digital/DTS surround modes

Press to select Dolby Digital or DTS surround modes (with suitably encoded digital source material). These modes can only be decoded from digital audio sources (via Coaxial, Optical or HDMI inputs).

19 Video input type

Press to select the video input type (Composite, S-Video, Component Video or HDMI) you wish to use as the source of video for the current source input.

Note: The choices available depend on the connections that source supports on the rear panel and whether a HDMI input has been assigned to that source. The 650R cannot simultaneously receive HDMI audio and analogue video from the same source.

For any HDMI audio sources selecting analogue video will then cause the unit to switch to analogue audio as well. Digital audio via SPDIF/Toslink can then also be selected via the Audio Input Type button but not HDMI audio. Returning to HDMI video will allow selection of HDMI audio (or analogue or digital audio) again. All normal sources with HDMI audio output will have HDMI video output.

20 Analogue Stereo Direct

Press to listen directly to the analogue inputs for the current source with no analogue to digital or DSP processing for highest possible stereo sound quality.

21 Volume

Use to increase/decrease the level of the sound from the outputs of the 650R.

22 Mute/Display

Press to mute the sound from the main and pre-amp outputs of the 650R. Press again to cancel mute.

Note: Selecting a new source always cancels mute.

Press and hold to re-display the current decoding mode.

23 Video 3 source button

Press to select a video camera recorder/video games console connected to the Video 3 input sockets.

24 Video 3 input sockets

Connect a video camera recorder/video games console to the 650R. Audio/Video and digital optical inputs are provided.

Note: The L audio input is also used for the supplied auto setup microphone. Refer to the 'Auto setup' section of this manual for more information.

Rear panel connections

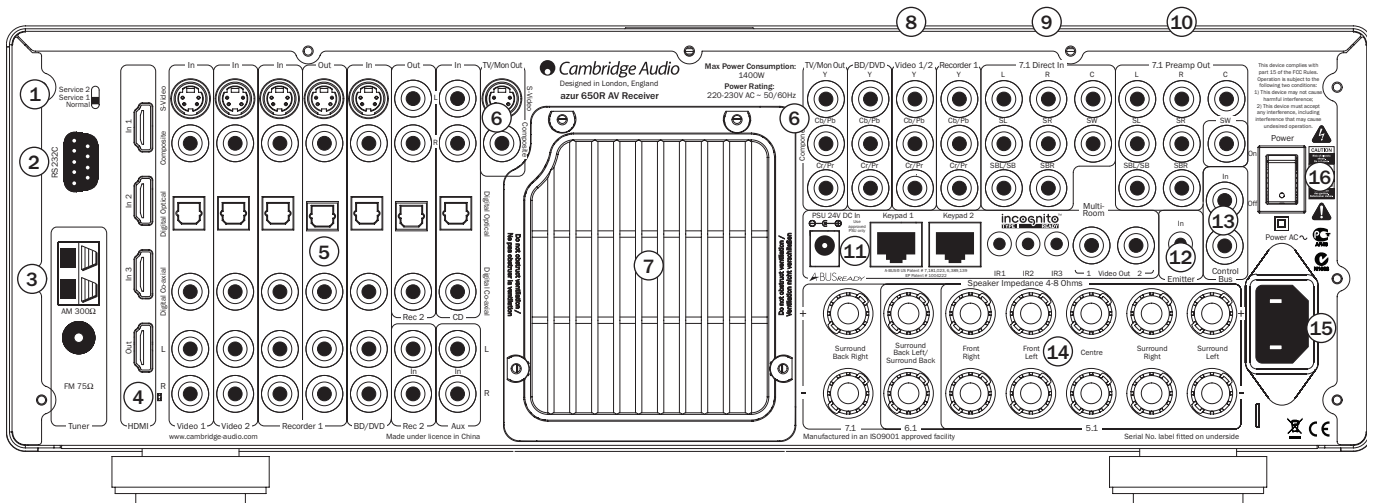

① Service/Normal

For dealer use only - Switches the 650R between normal (default) mode and two Service modes. Do not change the mode to service or make RS232 connections to it in service mode as damage may result!

② RS232C

Used for control of the 650R in Custom Install situations. A full protocol is available for the 650R on our website.

③ FM/AM antenna

All tuner antenna connections are made here. Refer to the 'Antenna Connections' section of this manual for more information.

④ HDMI

Inputs and output to a suitable TV/Monitor. The HDMI inputs can be assigned in the OSD to the BD/DVD, Video 1, Video 2 or Rec 1 sources, see later section.

⑤ Video 1/2, Recorder 1/2, BD/DVD, Aux

Please refer to the connection diagrams later in this manual for more information on these inputs and outputs.

⑥ TV/Mon outputs

S-Video - Connect to your television via S-Video cable.

Composite - Connect to your television via 75 ohm RCA phono cable.

Component - Connect to the Cr/Pr, Cb/Pb, & Y terminals of a television set.

⑦ Heat tunnel vent grille

Allows cooling of internal circuitry via the 650R's proprietary X-TRACT heat tunnel. **DO NOT OBSTRUCT!**

⑧ Component Video inputs (BD/DVD, Video 1/2, Recorder 1)

Connect the Component Video outputs from the source equipment.

The Video 1/2 input can be used for either source simply by selecting HDMI for either source using the Video Input Type button or doing the same thing via the Video Input Type menu in the OSD.

Note: The preferred connection method for video inputs or outputs is always Composite Video, then S-Video, then Component Video, then HDMI in ascending order of quality (HDMI being the highest quality). HDMI and Component Video sources often also support Progressive Scan which gives better picture quality if supported by both your BD/DVD player and TV.

⑨ 7.1 Direct In

Connect to the output terminals of a DVD-A, SACD player or other 5.1/6.1/7.1 analogue source.

⑩ 7.1 Preamp Out

Connect to the 5.1/6.1/7.1 channel input terminals of another amplifier system, separate power amps, subwoofer or active loudspeakers.

⑪ A-BUS™ Ready/Incognito Ready™ multi-room outputs

PSU In - Connect an Incognito PS5 to supply power to the connected multi-room keypads/speakers.

Keypad 1/2 - Connect one or two Incognito A-BUS KP10 keypads (or other A-BUS compatible keypads) or AS10 Active Ceiling Speakers using CAT5/5e cable, allowing 2nd/3rd zone multi-room capability.

IR - Three IR emitter outputs for remote control of source equipment.

Video Out 1/2 - Provides video feeds to the 2nd/3rd zone.

Please refer to the 'Multi-Room' section of this manual for more information on connections and setup.

⑫ Emitter In

Allows modulated IR commands from multi-room systems or IR repeater systems to be received by the 650R. Commands received here are not looped out of the Control Bus. Refer to the 'Custom Installation' section for more information.

⑬ Control Bus

In - Allows un-modulated commands from multi-rooms systems or other components to be received by the unit.

Out - Loop out for control bus commands to another unit.

⑭ Speaker terminals

Connect to loudspeakers with an impedance of between 4-8 ohms. 7.1, 6.1, 5.1 or less connections can be made.

⑮ Mains power lead

Once you have completed all connections, plug the AC power lead into an appropriate mains socket. The AV receiver is now ready for use.

⑯ Power On/Off

Switches the unit on and off.

Remote control

The 650R is supplied with an Azur Navigator remote control. Insert the supplied AAA batteries to use. For full details of the various adjustment functions available from the remote, refer to the later sections of this manual.

Standby/On

Switches the unit between Standby mode and On.

Analogue Direct

Directly selects a stereo analogue input for the current source with no A/D conversion or DSP processing.

Stereo Modes

Selects Stereo or Stereo + Sub modes for Analogue or Digital sources (digitally processed).

PLIIx/Neo/DSP

Selects from various matrix encoded surround processing modes for analogue or digital sources (digitally processed).

DD/DTS Modes

Selects digital surround processing modes for Digital/HDMI sources only.

Dynamic

Press repeatedly to reach the desired dynamic compression range (Dolby Digital or DTS modes only).

Sub On/Off

The *Sub On/Off* button performs temporary muting of the Subwoofer without affecting the bass management or speaker settings. Pressing the *Sub On/Off* button again or selecting another decode mode cancels Sub Mute.

To make permanent settings to the speaker options including the Subwoofer, use the 'Speaker Config Menu' in the On Screen Display (OSD).

Also, hold down and then press the volume up and down buttons to adjust the overall sub level if desired.

PTY (Program Type Search)

Press to search by program type when in Tuner mode. Refer to the 'Operating instructions' section of this manual for more information.

APS (Auto Program Search)

Hold down for 4 seconds to allocate and memorise radio stations automatically.

Display

Press to view the current source material and decoding mode. Press again whilst the current decoding mode is scrolling (as long as mute is not on) to display the incoming sample rate. When listening to FM with RDS, press to cycle round various RDS information modes.

Stereo Mono

When listening to FM, press to alternate between stereo and mono modes.

Store

Press to store the current frequency when in Tuner mode.

Mode

Press to select Auto/Manual or Preset tuning when in Tuner mode.

Mute

Mutes the audio on the AV Receiver. Press again to cancel mute.

Volume

Increase or decrease the volume of the AV receiver output. Also used as up/down in the OSD setup menus.

Tune / Left & Right

Press the right arrow to increase tuner frequency/change preset. Press the left arrow to decrease tuner frequency/change preset. Also used to scroll left/right in the OSD setup menus.

Enter

Used in the OSD setup menus.

On-Screen Display (OSD)

Press to turn on and off the on-screen setup menus for display on your monitor/screen.

Bass/Treble

Press for bass/treble adjustment, using the Volume up/down buttons. **Note:** Bass/Treble is bypassed in analogue stereo direct and 7.1 direct modes.

7.1 Direct

Selects the 5.1/6.1/7.1 direct input.

Audio In Type

Switches the audio between the types available for the current source. Depending on the source selected and whether you have assigned an HDMI input to it, Analogue, Digital and HDMI can be available.



Video In Type

Switches the video between the types available for the current source. Depending on the source selected and whether you have assigned an HDMI input to it, Composite, S-Video, Component and HDMI types can be available.

Note: The 650R cannot simultaneously receive HDMI audio and analogue video from the same source.

For any HDMI audio sources selecting analogue video will then cause the unit to switch to analogue audio as well. Digital audio via SPDIF/Toslink can then also be selected via the Audio Input Type button but not HDMI audio. Returning to HDMI video will allow selection of HDMI audio (or indeed analogue or digital audio) again.

Lip sync

Press to activate and adjust the lip sync delay function if the audio and video appear out of sync. While the Lip sync delay status is shown on the units display, use the Vol  and Vol  buttons to adjust the delay time. Adjusting the value to zero causes lip sync delay to be turned off. See later section in this manual.

Tuner AM/FM, BD/DVD, Video 1, Video 2, Rec 1, Aux, CD, Rec 2

Press the corresponding button to change the input source. Pressing the Tuner AM/FM button a second time toggles between AM and FM modes.

The above button descriptions are naturally brief. Please refer to the 'Operating Instructions' section of this manual for more information on the relevant functions implemented.

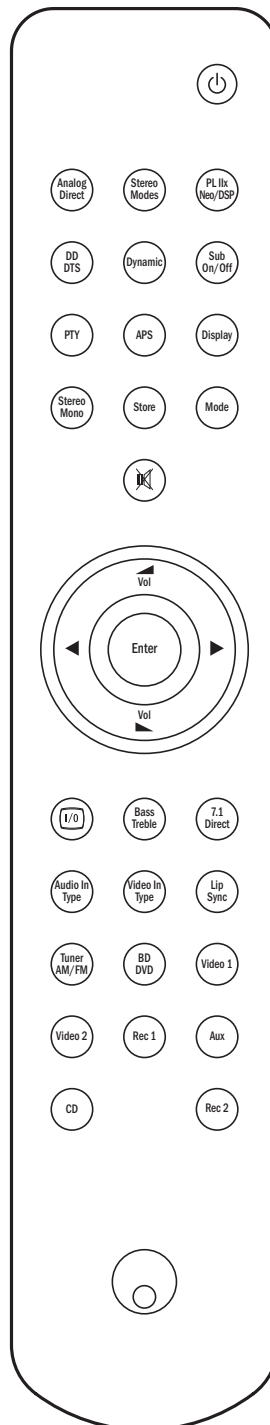

Front panel display

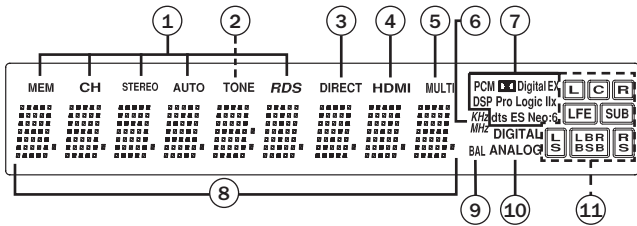

- ① Tuner mode indicators**
Shows Memory/Store active, Stereo mode active, AutoScan active and RDS On.
- ② Tone control indicator**
Lights when Bass and Treble controls are active.
- ③ Direct indicator**
Lights when the 650R is in a Direct mode - Analogue Stereo Direct or 7.1 Direct.
- ④ HDMI**
Indicates the current source audio input type is HDMI.
- ⑤ Multi**
Indicates the 650R is receiving multi-channel PCM over HDMI
- ⑥ Frequency type**
Indicates the tuned frequency in AM or FM Tuner mode.
- ⑦ Decoding mode indicators**
Shows the current decoding mode, Dolby Digital, DTS etc. In conjunction with the Output Channel indicators these give full details of the current processing mode.
- ⑧ Main information display**
Shows the current source selected, also the surround mode and station name/frequency when in tuner mode etc.
- ⑨ Balance indicator**
Lights when the Front Left and Right speaker outputs have been set to different levels in the OSD, i.e. a balance adjustment has been made.
- ⑩ Digital/Analogue indicators**
Indicates the current source audio input type is Digital (SPDIF/Toslink) or Analogue.
- ⑪ Output channel indicators**
Shows the currently active channels depending on decoding mode and source material. Icons lit indicate active channels in the source material. Icons with a box around them indicate actual channels being output by the 650R.

Display examples

	<p>- Indicates a 5.1 Dolby Digital source being played back as 5.0 (Sub off). The lit LFE indicates a low frequency effects channel is present in the source material. When this icon isn't boxed it indicates the LFE channel is not being sent to a subwoofer but will be mixed into the front left and right instead.</p>
	<p>- Indicates a 7.1 playback of DTS ES material.</p>
	<p>- Indicates a 2.1 output created in the digital domain from analogue input material.</p>

Loudspeaker connections

To avoid damaging the speakers with a sudden high-level signal, be sure to switch the power off before connecting the speakers. Check the impedance of your speakers. Speakers with an impedance of between 4 and 8 ohms (each) are recommended.

The coloured speaker terminals are positive (+) and the black speaker terminals are negative (-). Make sure correct polarity is maintained at each speaker connector or the sound can become weak and "phasy" with little bass.

Prepare the speaker cords for connection by stripping off approximately 10mm (3/8") or less (no more than 10mm, as this could cause a short-circuit) of the outer insulation. Twist the wire tightly together so there are no loose ends. Unscrew the speaker terminal knob, insert the speaker cable, tighten the knob and secure the cable.

Note: All connections are made via loudspeaker cable, except if using an active subwoofer which would be connected via a standard RCA phono cable.

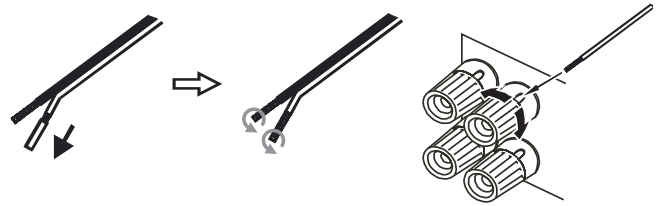

Banana Plugs (4mm standard) connected to the speaker cable are recommended for direct insertion into the speaker terminals.

Please refer to the 'Speaker Configuration' section of this manual for more information on 5.1, 6.1 and 7.1 speaker setups.

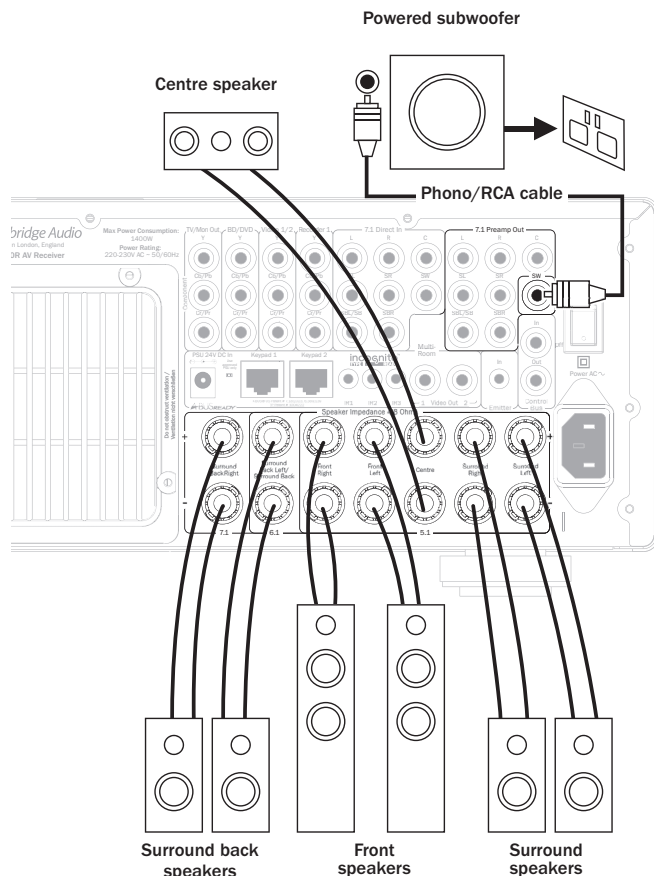

Analogue audio connections

Note: Do not plug in the mains power lead or turn the unit on until all connections have been made.

Connect to source equipment using stereo phono cables (stereo 2RCA-2RCA). Tape/MD/CDR recorder/players require two sets of stereo phono/RCA cables, one for recording, one for listening.

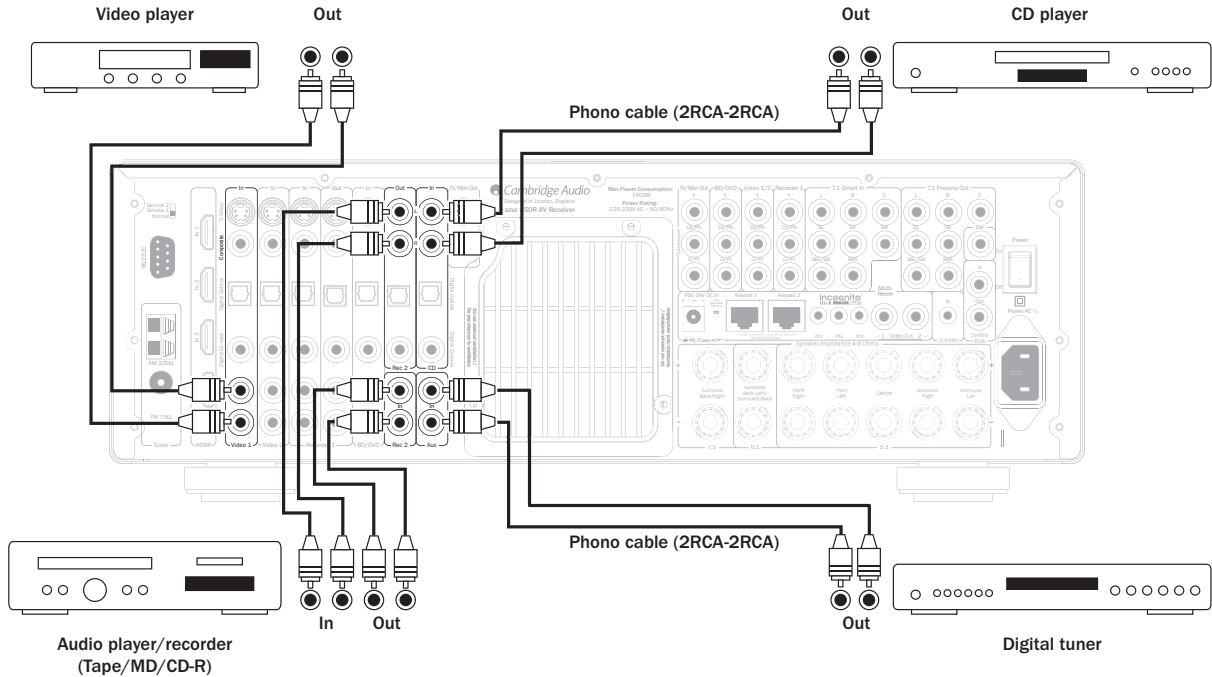

Digital audio connections

Two types of digital audio connections can be made to the 650R:

1. Optical (Toslink)
2. Coaxial (SPDIF)

Either type can be used for a source as the 650R automatically uses the active one.

Note: Only one connection type should be used per source.

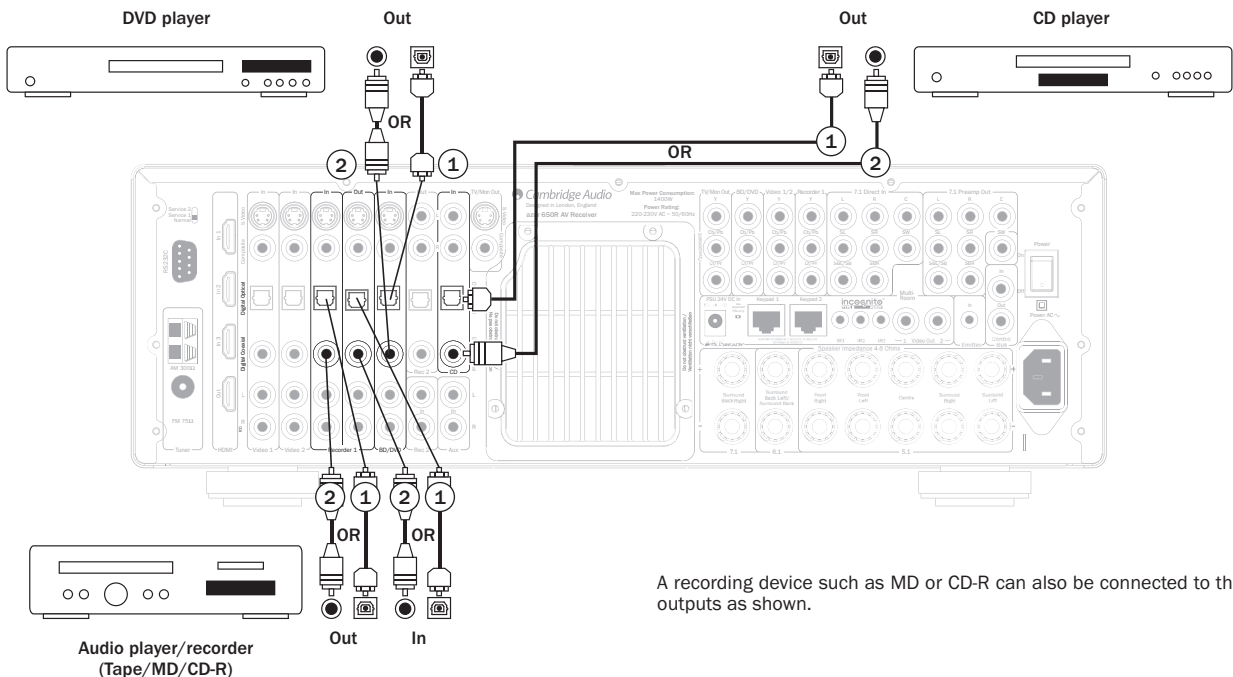

A recording device such as MD or CD-R can also be connected to the digital outputs as shown.

HDMI input connections

HDMI (High-Definition Multi-Media Interface) is an all digital connection that can carry both audio and video in one cable. Direct digital transfer of audio and video and support for various types of High Definition video content and high resolution audio make this the best connection type to use. The 3 HDMI inputs can be assigned to the BD/DVD, Video 1, Video 2 or Recorder 1 sources (see the "Assigning HDMI sources" section for more information).

DVI switching can be supported simply by using DVI to HDMI adaptors as these two connection types are compatible. When using DVI only video will be passed to the TV/Monitor and a Co-axial (SPDIF) or Optical (Toslink) digital

audio connection must be made from each source to the 650R for it to be able to receive audio and decode surround sound etc.

Note: As the 650R is unable to downwards convert HDMI video to analogue video if you wish to make an HDMI connection to the unit and then watch the same source in Zones Two and/or Three (requires Incognito keypads and PSU to be added see later section) you should make an additional parallel analogue video connection from the same source for use by Zone 2.

Nearly all BD/DVD player etc. feature analogue video outputs independent of their HDMI outputs making this a simple connection to make.

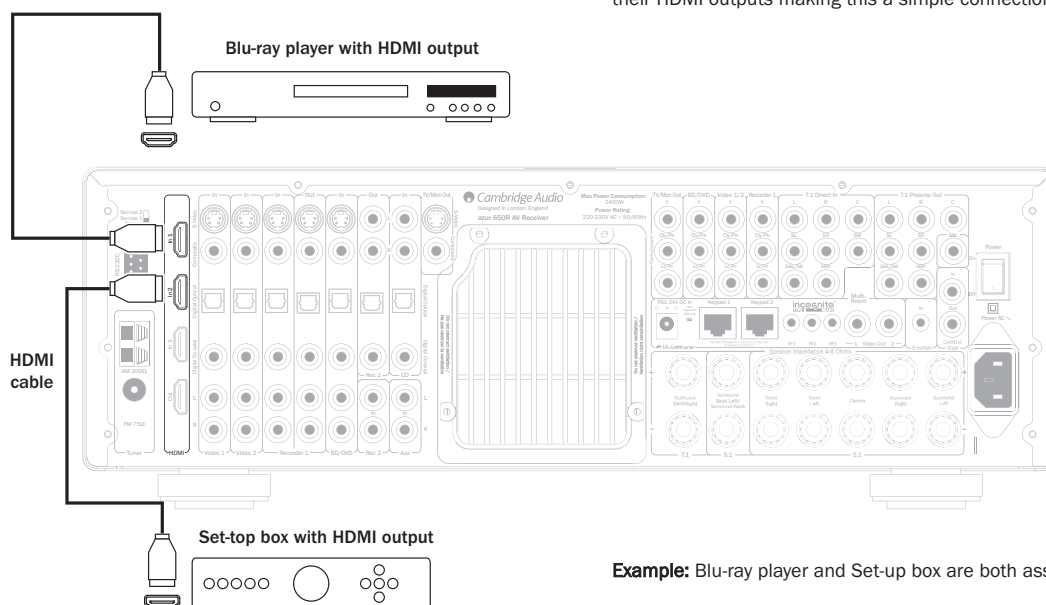

Example: Blu-ray player and Set-up box are both assigned to HDMI input.

Analogue video input connections

Three types of analogue video connections can be made to the 650R:

1. Composite - connect with single 75 ohm video phono cable (RCA-RCA).
2. S-Video - connect with S-Video cable.
3. Component - connect with 75 ohm Component video cables (3RCA-3RCA)

For sources that support HDMI this is always the best choice. See later section.

For sources that only support analogue video for best picture quality we recommend making Component video connections, then in declining order of quality, S-Video connections and then Composite video connections.

The 650R is able to transcode i.e. upconvert/downconvert analogue video to the other variants and also to HDMI for its all of its main monitor/TV outputs and the Incognito Ready Zone 2/3 outputs (requires Incognito keypads and PSU to be added see later section) so you are free to use whichever variant your source supports.

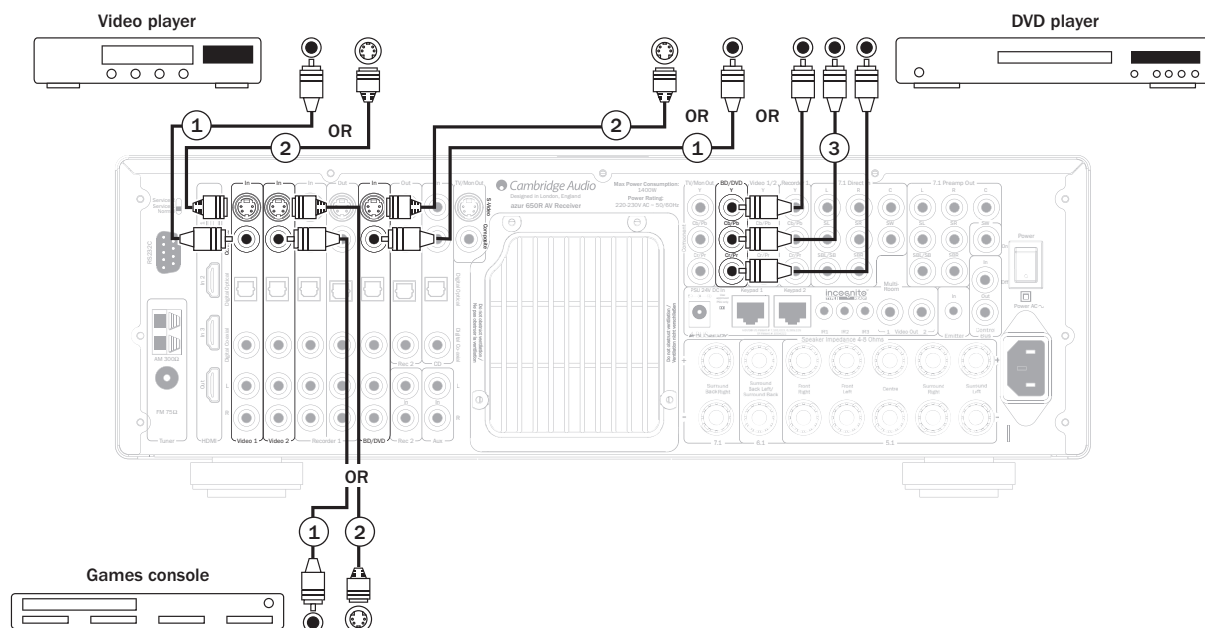

Video output connections

Connection to the TV can be by (in ascending order of quality) Composite Video, S-Video, Component Video and HDMI. HDMI is the recommended connection and the 650R can in addition transcode any analogue video sources to HDMI for a single connection to the TV.

Note: The 650R is unable to down-convert HDMI so if an HDMI source connection is made to the 650R you must make an HDMI output connection to the TV to view this source.

See later section on Video Connection Type in the Setup section for more details.

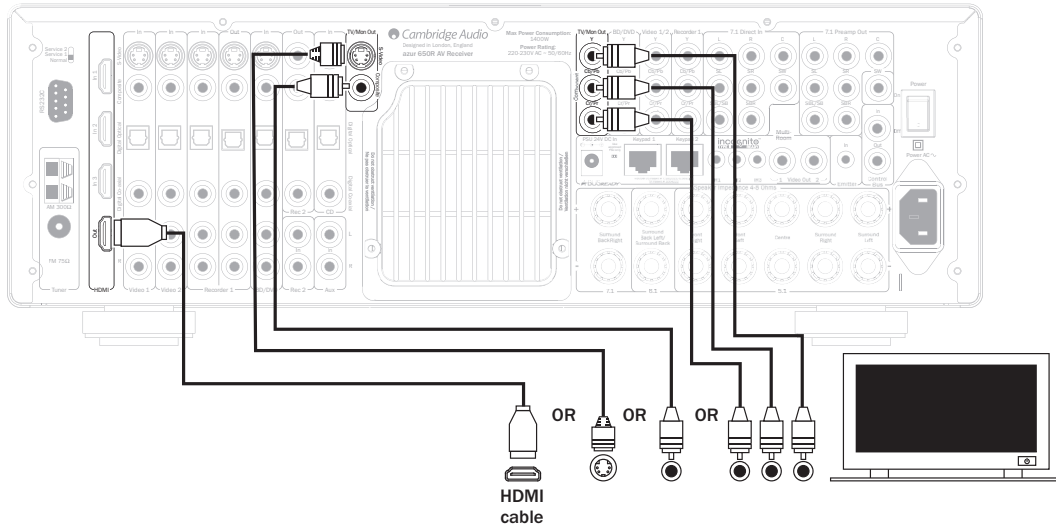

5.1/6.1/7.1 Direct in

DVD-A or SACD players can be connected to the 650R via its 5.1/6.1/7.1 Direct inputs allowing multi-channel music playback from these new sources.

DVD-A and SACD both support 5.1 output. The 650R's direct inputs also allow optional connection of Surround Back or Surround Left and Surround Right signals for compatibility with future 6.1 or 7.1 sources or external decoders.

To select the Direct Input press the *7.1 Direct* button on the front panel or remote.

Note: The 650R leaves the current video source selected for viewing when you select 7.1 Direct for audio.

This can be useful for universal DVD/DVD-A/SACD players for instance which can be connected to the 650R by two methods for audio at the same time.

A Digital or HDMI input can be made to the 650R for surround sound decoding and an analogue 5.1 connection to 7.1 Direct for DVD-A/SACD playback.

If the player is selected via the BD/DVD button you can then view its content and decode any relevant surround sound soundtracks.

If 7.1 Direct is then pressed, the players video is still available (for setup or other use) and the audio is now switched to come from the players analogue outputs.

These connections are pure analogue for best sound quality and no DSP processing or Bass and Treble adjustment by the 650R is possible.

DVD-A player or SACD multi-channel player 5.1 connections

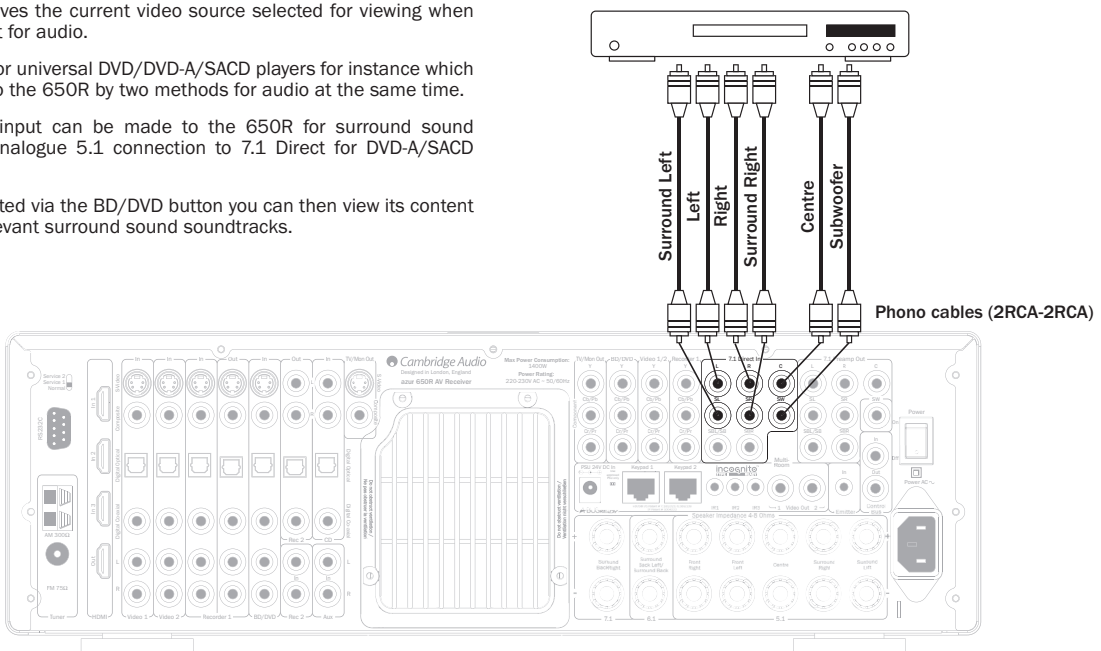

7.1 Preamp out

If it is desired to connect external power amplifiers, use Phono/RCA leads connected to the 7.1 Preamp Outputs on the rear panel.

For 5.1/6.1/7.1 use set the 'Preamp Out' setting in the 'Output Setup' OSD menu to 'Pre Out' rather than 'Normal'. This mutes all the internal power amplifiers as they are not being used.

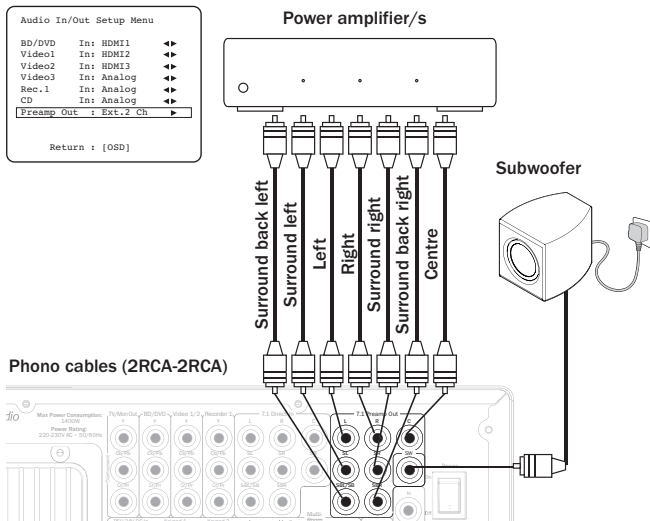

Alternatively the 650R features an External 2-Channel mode. This allows the 650R to reproduce all the surround channels of suitable source material (Centre, Surrounds and Sub) whilst the Left and Right Front speakers are driven by an external power amplifier or other amplifier capable of supporting fixed level inputs (e.g. Cambridge Audio's own 740A or 840A amplifiers).

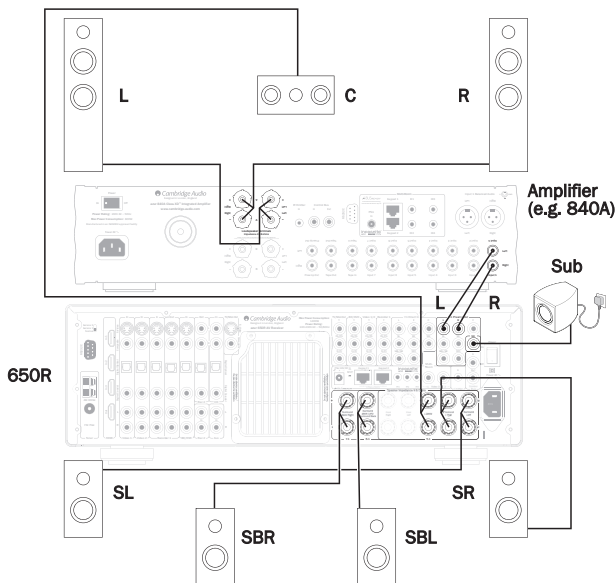

Set the 'Preamp Out' to 'Ext 2 Ch' in the OSD to mute the front left and right amplifier outputs only:

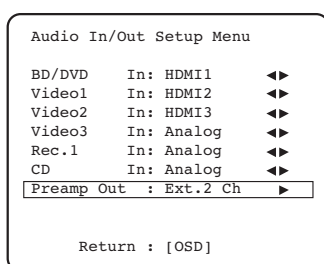

Front input connections

The front panel Video 3 input is for temporary connections to video games consoles etc. Remove the cap to access the Video 3 inputs, and connect to a video game console or video camera's outputs using stereo phono cable (RCA-RCA) and either (1) Composite or (2) S-Video cable, depending on what your unit supports (S-Video preferred).

If your games console has an optical digital output this can also be used, allowing the 650R to decode surround sound information if the console/game supports it.

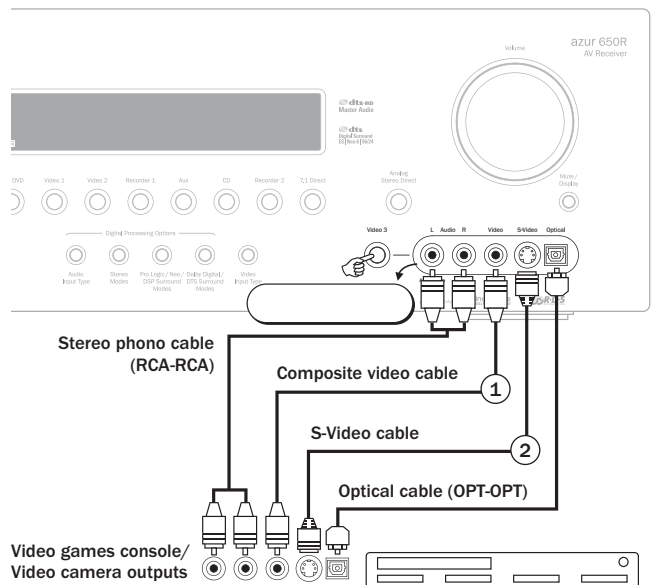

Note: The Left front input is also used for the supplied auto setup microphone. Refer to the 'Auto setup' section of this manual for more information.

Aerial connections

FM aerial

Connect an aerial to the FM 75 ohm socket (a simple wire aerial is supplied only for temporary use). Extend the lead and move the aerial around until you get the best reception. For continued use, we strongly recommended using a 75ohm outdoor FM aerial.

AM loop aerial

Connect each end of the single length antenna to the antenna terminals. Place the antenna as far from the main system as possible to prevent unwanted noise and to obtain optimum reception. If the AM loop aerial provided does not receive sufficient reception, it may be necessary to use an outdoor AM aerial.

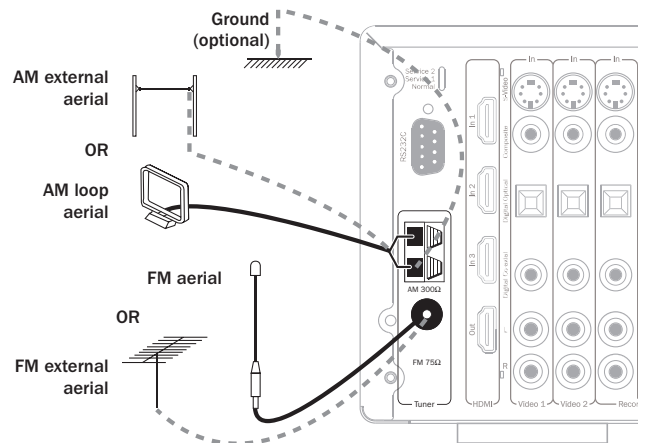

650R setup

The setup of the 650R is a reasonably simple 4 stage process. The speaker setup process (stage 2.) can either be performed manually or via the CAMCAS (Cambridge Audio Microphone Controlled Auto Setup) procedure.

The procedure is as follows:

1. Speaker configuration.
2. Speaker setup (Speaker delay and Level calibration)
3. Assigning any HDMI sources
4. Source setup (Audio type and Video type for each source)

1. Speaker configuration

First tell the unit what kind of speaker package you have. The options are 5.1, 6.1 or 7.1 as shown below. The 650R can support up to a 7.1 speaker setup which means 7 speakers (Front Left, Front Right, Centre, Surround Left, Surround Right, Surround Back Left, Back Right) plus a mains powered Subwoofer (the .1).

Refer to the diagrams below for typical examples of 5.1, 6.1 and 7.1 loudspeaker setups. Always adjust the speaker and listening positions until you are happy with the sound. Please refer to your loudspeaker and subwoofer manuals for more detailed positioning information.

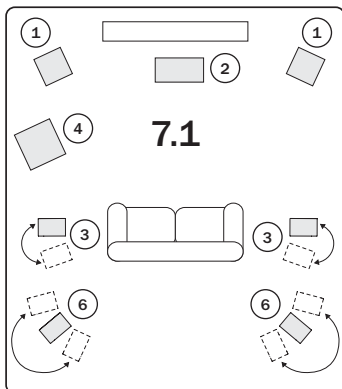
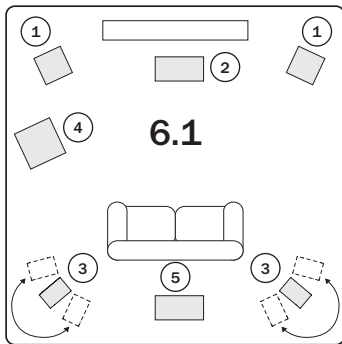
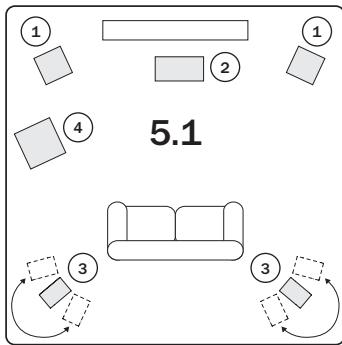

① Front Left and Right speakers

For stereo and multi-channel sound.

② Centre speaker

For dialogue and centre sounds. Ideally position at a similar height to the front left and right speakers (above or below the TV/monitor). Using a centre speaker from the same manufacturer/range as used for the front left and right speakers is advisable. This “timbre matching” allows surround effects to flow more naturally from left to right without obvious transitions between the speakers.

③ Surround Left and Right speakers

For ambient and multi-channel sound. Floorstanding speakers should be angled towards the listening position. Bookshelf/standmount speakers should be wall mounted or used with dedicated speaker stands, positioned at or above ear height.

④ Subwoofer

For improving the bass in your system, as well as reproducing dedicated LFE (Low Frequency Effects) cinema effects when playing Dolby Digital or DTS encoded discs. Your subwoofer can often be placed almost anywhere in the room as bass is less directional, but experimentation with positioning is recommended.

⑤ Surround Back Centre speaker

Sixth channel speaker required for enjoying Dolby® Digital EX or DTS®-ES or other 6.1 audio. Improves the quality of sound effects by filling the gap between the surround left and rear right speakers. Position the speaker firing towards the front of the room.

⑥ Surround Back Left and Right speakers

Individual back speakers in place of a single surround back. Used with the very latest 7.1 processing types. Remember to experiment with the positions until you are happy with the sound.

In each case the 5.1/6.1/7.1 in fact relates to the maximum number of speakers that can be used, as the Centre, Sub and Surround speakers can all be deleted if required (although of course performance is reduced). For example, if you choose not to use a Centre Channel speaker you can set this to 'None' in the settings as shown later and the 650R will automatically redirect the centre channel audio information into the Left and Right Front channels, creating what is known as a 'Phantom Centre'.

Similarly, you might decide not to use a subwoofer if your main Left and Right speakers are capable of reproducing enough bass for a satisfying music/movie experience. The 650R will then automatically re-direct the bass from the Subwoofer/Low Frequency Effect channel to the Left and Right Front Speakers.

Note: This setup is very important as the 650R will also automatically use this information to select appropriate Dolby and DTS decoding modes dependant not only on the source material but also the speaker package it knows you have.

To tell the unit the type of package you have, turn on the On-Screen Display via the remote button as shown. Highlight the 'Speaker Configuration' menu by using volume up and down on the remote then go to it by pressing *Enter*:

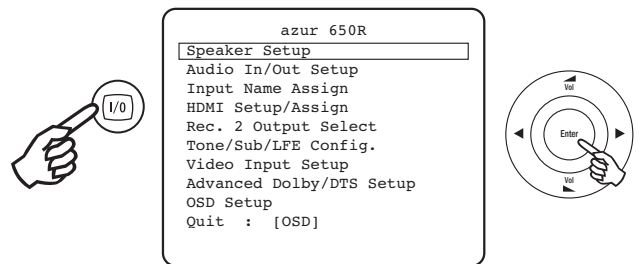

Set the package as 5.1, 6.1 or 7.1 by highlighting the Decode Mode item and using the *Left* and *Right* arrows to scroll through the options:

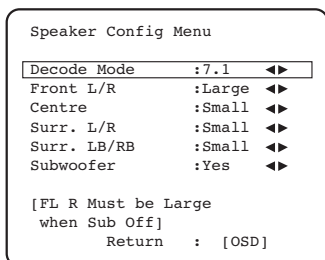

Now move down and by highlighting each speaker in turn and using the *Left* and *Right* arrows select from 'Large', 'Small' or 'None' for each speaker. 'Large' or 'Small' are used to describe each speaker in terms of bass response, they do not necessarily reflect the actual physical size of the speaker.

Large = Speakers with an extended low frequency response of approximately 20-40Hz to 16-20kHz (floorstanders or high quality larger stand-mounted speakers).

Small = Speakers with a less extended low frequency response of approximately 80-100Hz to 16-20kHz (small stand-mounted, bookshelf or satellite speakers).

Setting each speaker allows the 650R to perform what is called Bass Management and to direct low frequency bass from music and the Low Frequency Effects channel of surround sound material to those speakers best able to reproduce it. If you do not wish to use any of the speakers set its setting to 'None'.

The Subwoofer output can also be set to On or Off. If no sub is being used make sure this setting is set to Off to allow the 650R to re-direct the bass information in this channel to other speakers.

Note: The 650R will force some speakers to certain settings in some of the following circumstances!

The Front Left and Right speakers may be 'Large' or 'Small' but never 'None' as they are always required for any type of music/movie reproduction.

Bass must always be reproduced by either the Front Left and Right or Subwoofer channel (or both). Setting the Front Left and Right to 'Small' will result in the Subwoofer automatically being set to 'On'. Setting the Subwoofer to 'Off' will automatically result in the Front Left and Right being set to 'Large'.

If the Front Left and Right cannot reproduce low frequency bass a Subwoofer must be used. I.e. If the Front Left and Right are set as 'Small' the Sub must be Set to 'On'.

Also, setting the Front Left and Right as 'Small' will always set the other speakers as 'Small' (and the Sub to 'On'). This is because LFE/ bass information should not be redirected to the surround channels.

To store the setting simply come back out of the OSD (pressing the OSD button always moves back one menu item, and then exits and stores from the main menu screen).

2. Speaker setup

The following two sections can be performed by Cambridge Audio CAMCAS procedure so you can if you wish jump straight to that section. However, it is recommended that you do read these sections to understand the reasons for these settings and their implications.

Speaker delay

Because the speakers in a surround sound system are usually different distances from the listener the 650R incorporates the ability to apply a variable digital delay to each of the channels so that the sound from each arrives at the same time at the listening position for best surround-sound effect.

To set the delay times automatically, refer to the Auto setup section of this manual.

To set the delay times manually, simply measure the distances from the listening position to each speaker as shown in the following diagram:

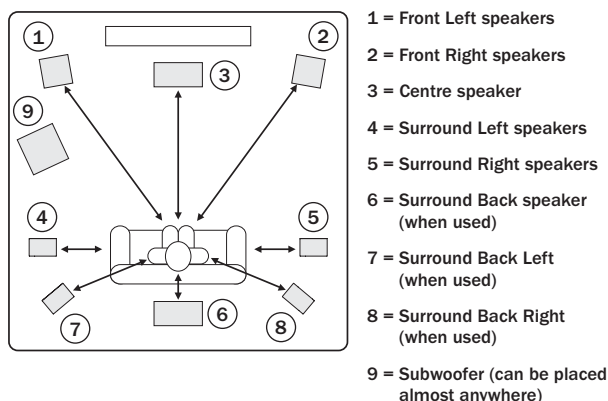

Note: No delay setting for the subwoofer is necessary.

Set the distances in the OSD Speaker Distance menu to the nearest value in metres (1 foot = 0.3 metres). The speed of sound is approx 340 metres per second, the 650R thus introduces approx 3mS of delay per metre of distance set.

Go to the 'Speaker Distance' and highlight each speaker in turn. Set the distance to the nearest value to that which you measured by using the *Left* and *Right* arrows (the values do not need to be exact):

Press the OSD button to exit the menu.

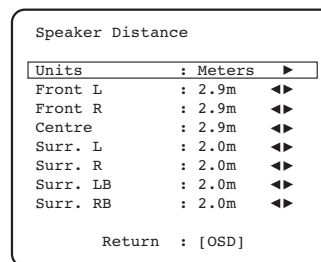

Note: In addition to the delays as set above Dolby Pro Logic II/IIx playback also requires an extra 15 milliseconds delay to the surround channels only. This extra delay is part of the Dolby Prologic II specification and ensures that sound from the surrounds arrives just after sound from the front reducing the audibility of sound leakage from the front to the surround speakers. Because the relationship between the Dolby Digital and Dolby ProLogic IIx two delays is fixed (15mS extra to the surround channels), it is only necessary to set the delay by measuring the distances as we have described. The 650R will automatically provide the appropriate extra delay whenever you switch to a Pro Logic Mode.

Level calibration

The 650R allows level calibration to match the acoustic level between different types/sizes or even manufacturers of speaker that may be being used for each channel. This is achieved by adjusting the relative level of each speaker. This can be done manually through the 'Level Calibration' menu in the OSD or automatically, see the following Auto setup section of this manual.

The basic process for manual adjustment is to listen to or measure with an SPL meter (more accurate and recommended but not essential) the level of sound produced by each speaker and set relative levels for each speaker so that they all sound the same loudness at the normal listening position. The 650R incorporates a Test Signal Generator (broad-band white noise) to facilitate this.

Set the unit to a normal listening level or half maximum volume approximately. Press the OSD button on the remote control then select the 'Level Calibration' menu. Now turn on the test signal by highlighting this item and pressing the *Left* or *Right* arrows:

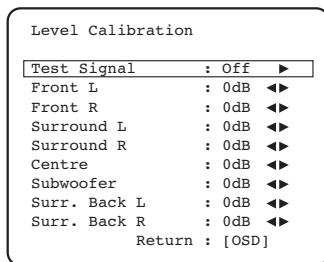

A "rushing" or "hissy" sound should be heard, initially through the Front Left Speaker.

You can now move up and down the channels using *Volume Up/Down* on the remote. Each time a new channel is selected the test signal will be heard to move to that channel. Compare the loudness of all channels as heard at the listening position.

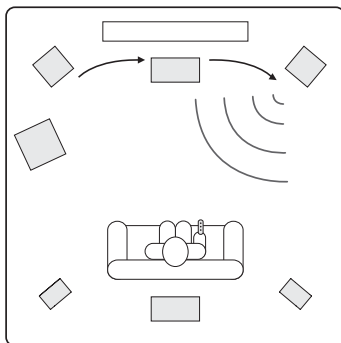

Now adjust the channels so they all sound the same (in terms of loudness only, channels of different frequency responses can sound different in terms of the "tone" of the sound i.e. more or less hissy).

Pick the channel that sounds most different and select it to listen to the test signal. Now adjust the relative level in dB (using Arrow left/right on the remote) and continue comparing it to other channels until it is of equal loudness. The level can be adjusted up to + or - 10dB in 1dB steps. Repeat the process with the next loudest channel etc. Once all channels sound the same in terms of loudness, press the OSD button again to save the settings and exit the menu.

Auto speaker setup for Distance/Level

The 650R includes our simple automatic speaker setup system called 'CAMCAS' (Cambridge Audio Mic Controlled Auto Setup). The system performs two sets of tests firstly checking which speakers are connected and whether they are wired correctly and in phase then automatically measuring and adjusting the speaker delay timings (i.e. distance setting) and levels.

Before activating this feature the 'Decode Mode' (i.e. type of speaker package e.g. 5.1, 6.1, 7.1) of the 650R and Large/Small/None status of each speaker must be set correctly as per section 1. This is important as the unit will only look for and check the speakers you have told it you have.

To perform Auto Distance/Level setup first connect the supplied microphone to the front Left front panel audio input on the front panel and place it at your normal listening position in the room.

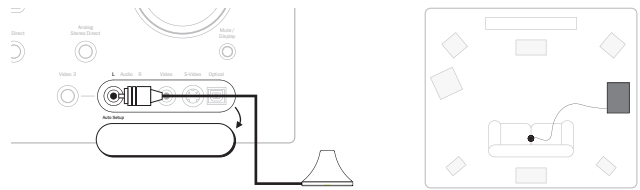

Press the OSD button on the remote control to access the OSD and then select the Speaker Setup Menu. Now select the option 'Auto Setup'. This will access the 'Auto Setup Menu' as below.

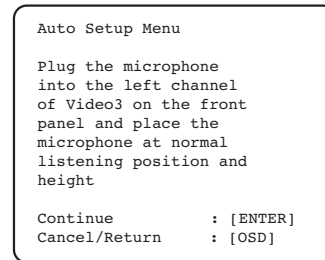

Follow the on-screen instructions and press 'Enter' on the remote control when ready to start the Auto Setup function.

Once activated the OSD will display the message below and the word 'AUTOSUP' will also be displayed on the front panel of the 650R to confirm.

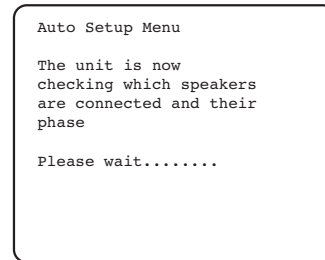

A series of test signals will now be output from all of the connected speaker terminals of the 650R (including the Subwoofer output).

Once finished the unit will display a screen similar to the one below reporting which speakers were found and any that appear out of phase.

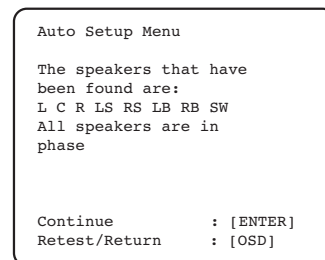

If any speakers appear unconnected or out of phase carefully check the connections on the speaker and the back of the unit. Also check any bi-wiring links that might be present on the speaker. For any out of phase speakers check that the relevant + terminal of the 650R goes to the + terminal of that speaker and similarly the - terminal of the 650R goes to the - terminal of the speaker for that channel.

If necessary press the OSD button to perform a retest or press Enter to start the second part of the autoseup procedure as below.

Again a series of test signals will now be output from all of the connected speaker terminals and Subwoofer. The 650R uses these to measure the levels and distances (and hence introduce the correct delays) appropriate to your speakers and room characteristics.

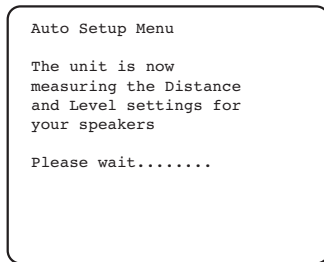

When the auto setup of the 650R is completed successfully, the 650R will return to the Speaker Setup Menu.

The Speaker Distance and Level Calibration settings for each speaker will have been updated.

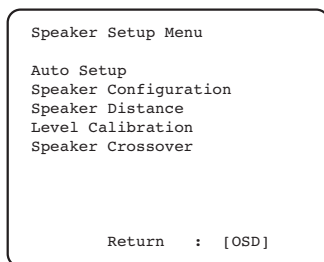

It is of course now possible to go into the Speaker Delay and Level Calibration menus if you want to manually check/adjust the settings made by the CAMCAS system, and it is always advisable to check them as no system can be totally foolproof.

To exit the auto setup menu of the 650R continue to press the OSD button on the remote control to exit all menus or until 'OSD' is no longer displayed on the front panel. You can now unplug the microphone and put it away for future use.

Note: If the auto setup of the 650R is unsuccessful for some reason a 'Fail' message will appear on the OSD. Included in this message will be details of the speaker channel or channels which have not been successfully adjusted. If this is the case, please again check that the speaker or speakers detailed in the OSD as 'failed' are connected correctly & have not been wired out of phase. Also check the microphone connection and any other external issues that could have affected the tests such as noise in the room etc.

Note: Like all such systems CAMCAS has some limitations. Speakers that exhibit very strong phase angles or deliberately wire some drive units out of phase can of course appear to the system as an out of phase speaker when correctly connected. If a speaker is reported as out of phase but is correctly wired please consult the speakers manufacturer in case this is the case.

Similarly bi-polar speakers which radiate in more than one direction can make it difficult to measure the distance and sometimes level accurately as you might expect.

In all cases it is always advisable to manually check the settings CAMCAS has made for a 'reality check' to ensure there are no obvious errors.

3. Assigning any HDMI (or DVI) sources

The 650R has 3 HDMI (High Definition Multi-Media Interface) inputs and one HDMI output. HDMI is a fully digital audio/video system that passes the picture and audio to the screen in digital format for best possible picture quality. DVI (Digital Video Interface) is a subset of HDMI that uses different connectors and only passes digital video to the TV/Monitor (no audio). The 650R is fully compatible with DVI in that simple passive DVI-HDMI adaptors are available which allow the conversion of the DVI connector to an HDMI format connector (and back again if required) for routing via the 650R. The 650R can switch both types of signal.

HDMI/DVI (henceforth referred to as HDMI) outputs on Blu-ray, DVD players and Set-top boxes also often support higher resolution formats including progressive scan types. Consult both your HDMI source and TV manuals for details, it is often possible to select from various options, you will want to select the highest quality output that both your source and TV are compatible with.

From Blu-ray players, HDMI can also carry the latest Dolby Digital Plus and True-HD formats as well as DTS-HD High Resolution and Master Audio.

Ensure that the HDMI output of your player has been set to 'Bitstream' or 'Raw' to pass the formats to the 650R for decoding.

Also some Blu-ray players feature settings to allow down conversion of Dolby Digital Plus etc. to backwards compatible Dolby Digital 5.1 for older AV receivers which do not support these formats.

Ensure any such settings are disabled to allow our 650R access to all the latest formats.

Each of the three HDMI inputs can be freely assigned to the DVD, Recorder 1, Video 1 or Video 2 inputs in the OSD. Select the 'HDMI Setup/Assign' menu:

The default setup is as below.

Highlight each HDMI input in turn and assign it to one of the 4 possible options (with the *Left* and *Right* arrows).

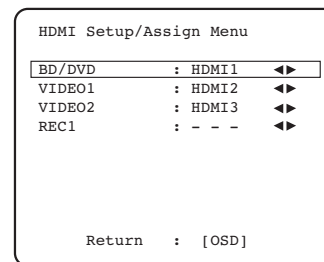

4. Source setup

The next step is to select each source input in turn on the 650R and tell the unit:

- The type of audio connection you want to use for that source (Analogue, Digital or HDMI)*.
- The type of video connection you want to use for that source (Composite, S-Video, Component or HDMI)*.
- The processing mode for that source.

The 650R remembers these settings individually for every source input and automatically recalls them as and when you change source input.

* Remember if you wish to use HDMI for any sources you must have assigned an HDMI input to them as per previous section.

Audio connection type

Select the 'Audio In/Out Setup' menu. Highlight each source in turn and select either analogue or digital input types (use the *Left* and *Right* arrows):

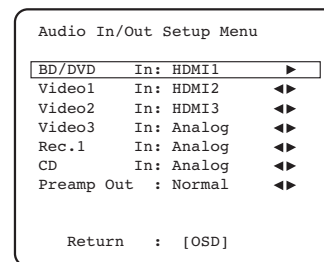

Analogue inputs will require a stereo phono/RCA to phono/RCA cable connection to the 650R. Digital inputs will require either a 75ohm digital type phono/RCA to phono/RCA co-axial cable (SPDIF) or an optical fibre cable (TOSLINK). The 650R will automatically use whichever is connected. Do not make connections to both the Optical and Co-axial inputs for a source.

Note: The Preamp output item at the bottom of this menu selects between Normal mode (the default), Pre Out Mode (when external power amps are used) and Ext 2 Ch Mode (where external power amps for front left and right only are used). These options are covered later. Make sure this setting shows Normal.

Once you have set the audio types exit the OSD to save.

This setting can also be changed at any time without using the OSD by pressing the *Audio Input Type* button on the front panel or remote, this will then cycle between analogue or digital input types for the currently selected source, as usual they will then be remembered the next time you return to that source.

4. Source setup continued

Video connection type

The 650R provides transcoding or up/down conversion between Composite, S-Video and Component video and up only to HDMI format. This function is very useful in that it allows for a single video connection type to be made to the TV/Monitor even if different input video connection types are used for different source inputs. As with the video inputs, the best output connection type to make to the TV/Monitor is (in declining order of quality) HDMI then Component, then S-Video then Composite.

When you set the Input Video type the 650R also automatically selects a transcoding mode as shown in the table below:

		ACTIVE MONITOR/TV OUTPUTS			
		Composite	S-Video	Component	HDMI
SELECTED VIDEO INPUT TYPE	Composite	Direct	Transcode	Transcode	Transcode
	S-Video	Transcode	Direct	Transcode	Transcode
	Component	Transcode**	Transcode**	Direct	Transcode
	HDMI *	Direct	Direct	Direct	Direct

This setting is remembered input by input.

* Only available where a HDMI input has been assigned to the source.

** Component video above standard definition (576i or 480i) cannot be converted to Composite or S-Video.

Note: The 650R is unable to down-convert HDMI so if a HDMI source connection is made to the 650R you must make a HDMI output connection to the TV as you might expect to view this source.

In all cases input by input, you need to tell the 650R which video type you are using for the source.

Select the 'Video Input Setup' menu. highlight each source in turn and select either Video, S-Video, YPbPr (Component) or HDMI (if that source has been assigned on HDMI input).

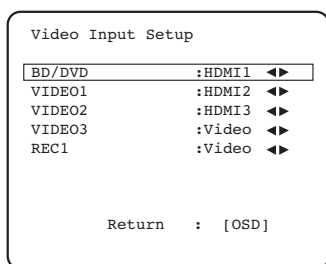

As well as for the main outputs the 650R also transcodes analogue video for the Incognito Ready Zone 2/3 composite outputs (requires Incognito keypad and PSU to be added see later section) so you are free to use any analogue video input variant for sources you wish to see in Zone2/3.

Note: As the 650R is unable to downwards convert HDMI video to analogue video if you wish to make an HDMI connection to the unit for the main outputs and then watch the same source in Zones 2 and/or 3 you should make an additional parallel analogue video connection from the same source for use by Zone2/3.

Nearly all BD/DVD player etc. feature analogue video outputs independent of their HDMI outputs making this a simple connection to make.

This setting can also be changed at any time without using the OSD by pressing the Video Input Type button.

This cycles round the types of analogue video connections that can be made on the 650R:

1. Composite Video (CVBS)
2. S-Video (S-VHS, Y/C)
3. Component Video (YCbCr / YPbPr, YUV)
4. HDMI (if assigned)

Surround sound modes

The 650R supports several music and home-cinema listening modes. The output the 650R can provide, depends both on the source signal present, the speaker setup selected and the decode mode selected. Before we describe how to operate the 650R, below is a brief guide to the Surround Sound formats that the 650R is compatible with for reference:

Dolby True HD

Dolby's lossless audio technology developed primarily for high capacity Blu-ray discs/players. Dolby True HD delivers theoretically bit-for-bit sound identical to the studio master by the use of 100% lossless encoding. Previous formats such as Dolby Digital 5.1 or EX have used lossy encoding where some data (that is theoretically less audible) is always lost in the encoding process to reduce the storage capacity needed on the disc. This is a new format that supports up to eight (usually used as 7.1) full-range channels of 24-bit/96 kHz audio or two channels of 24/192 kHz via Blu-ray discs and is not backwards compatible with earlier schemes. The format can either be transmitted as a 'bitstream' to the 650R for internal decoding (recommended) or can be decoded by some Blu-ray players internally and sent to the 650R as multi-channel PCM. In both cases an HDMI connection is required to the 650R and a suitable Blu-ray player as Dolby True HD is only ever transmitted over HDMI.

Dolby Digital Plus

A new encoding scheme based on the original Dolby Digital CODEC, but with enhancements to improve coding efficiency and improve audio quality. Dolby Digital Plus supports 7.1 fully discrete channels compared to Dolby Digital 5.1 (or 6.1 in its EX variant where the 6th channel is matrix encoded). These Dolby Digital Plus bitstreams are not backward compatible with legacy Dolby Digital decoders but require an AV Receiver developed to decode them (such as the 650R) and an HDMI connection as Dolby Digital Plus is currently only transmitted over HDMI. It is however a requirement that any Dolby Digital Plus enabled Blu-ray player must also be able to transform the Dolby Digital Plus into a backwards compatible Dolby Digital 5.1 output for playback on legacy Dolby Digital systems. The 650R is however fully compatible with Dolby Digital Plus.

DTS-HD Master Audio

A new lossless audio CODEC from DTS, rather than being incompatible with earlier versions, DTS-HD Master Audio is transmitted as an extension to a normal DTS bitstream. A second embedded stream is sent which contains the "difference" between the original studio master and the lossy compressed DTS, plus the two extra channels. DTS-HD Master Audio enabled devices (such as the 650R) are able to use this difference information to recreate a bit for bit lossless version of the original 7.1 data. Devices which do not support the Master Audio extension simply decode the original 5.1 DTS stream and ignore the Master Audio extension providing backwards compatibility.

DTS-HD High Resolution Audio

Known also as DTS-HR an extension to the original DTS audio format. DTS-HD High Resolution Audio supports 7.1 fully discrete channels compared to DTS's 5.1 (or 6.1 in its DTS ES Matrix or DTS ES Discrete variants). As with DTS-HD Master Audio a second embedded stream is sent which contains the "difference" between the original studio master and the lossy compressed DTS, plus the two extra channels, however in this case the extra stream is also formed by lossy compression. Effectively this is a 7.1 version of DTS which can be decoded by devices (such as the 650R) which are able to decode DTS-HD High Resolution Audio. Devices which do not support the High Resolution extension simply decode the original 5.1 DTS stream and ignore the High Resolution extension providing backwards compatibility.

Dolby Digital

Known also as DD (3/2) or DD 5.1, provides (up to) 5.1 output from suitable encoded Dolby Digital material, with 5 main channels (Front Left, Front Right, Centre, Surround Left, Surround Right) and a Low Frequency Effects Channel for the subwoofer, all discretely encoded. Decoding Dolby Digital requires a Dolby Digital encoded DVD disc and a digital connection from the source equipment (Such as a DVD player) to the 650R.

Note: Dolby Digital and DTS formats can sometimes carry less channels than their maximum such as Dolby Digital (2/0) which means a Dolby Digital encoded signal which is actually only carrying a two channel stereo signal (other channels inactive).

DTS

Known also as DTS (3/2) or DTS 5.1, DTS provides (up to) 5.1 output from suitable encoded DTS material, with 5 main channels (Front Left, Front Right, Centre, Surround Left, Surround Right) and a Low Frequency Effects Channel for the subwoofer, all discretely encoded. Decoding DTS requires a suitable encoded DTS disc and a digital connection from the source equipment to the 650R.

DOLBY DIGITAL EX | **Dolby Digital EX**

Known also as DD (3/3) or DD 6.1, an enhanced form of Dolby Digital. On top of the discretely encoded 5.1 channels DD EX provides an extra 6th channel (Surround Back, giving 6.1) matrix encoded into the rear surrounds for greater image depth and more solid sound localisation behind the listener. DD EX requires a DD EX encoded disc. DD EX is backwards compatible with DD 5.1 decoding. If DD EX is decoded as normal DD the Surround Back signal will be present in both Left and Right Rear Surrounds (forming a phantom rear centre). It can also be decoded as 7.1 by sending the Surround Back decode to both the Surround Back Left and Right speakers (forming two mono Back Surrounds).

dts Digital Surround | ES | **DTS-ES Matrix**

Known also as DTS (3/3) Matrix, an enhanced form of DTS. On top of the discretely encoded 5.1 channels DTS ES also provides an extra 6th channel (Surround Back giving 6.1), matrix encoded into the rear surrounds for greater image depth and more solid sound localisation behind the listener. DTS ES requires a DTS ES encoded disc. DTS ES material is backwards compatible with DTS 5.1 decoding. If DTS ES is decoded as normal DTS the Surround Back signal will be present in both Left and Right Rear Surrounds (forming a phantom rear centre). It can also be decoded as 7.1 by sending the Surround Back decode to the both the Surround Back Left and Right speakers (forming two mono Back Surrounds).

dts Digital Surround | ES | **DTS-ES Discrete**

Another enhanced form of DTS, also known as DTS (3/3) Discrete or DTS ES Discrete 6.1. DTS ES Discrete also provides an extra channel (Surround Back) for greater image depth and more solid sound localisation behind the listener, however in this case extra data is included in the bitstream so that all channels are discretely encoded. The Surround Back has greater separation from the other channels than is possible with matrix encoded technologies. DTS-ES Discrete requires a DTS-ES Discrete encoded disc.

DTS ES Discrete is backwards compatible with both DTS 5.1 and DTS ES Matrix 6.1 decoding. If DTS ES Discrete is decoded as normal DTS the Surround Back signal will be present in both Left and Right Rear Surrounds (forming a phantom rear centre). If DTS ES Discrete is decoded with DTS ES Matrix the Surround Back signal will be decoded separately (i.e. as 6.1) but by a matrix process, which will give the same channel separation as if the source disc were actually DTS ES Matrix (but not as good as DTS EX Discrete).

It can also be decoded as 7.1 by sending the Surround Back decode to both the Surround Back Left and Right speakers (forming two mono Back Surrounds).

DOLBY PRO LOGIC II | **Pro Logic II**

The replacement for original ProLogic, Pro Logic II is a technology where 5 channels (Front Left, Front Right, Centre, Surround Left, Surround Right) are encoded into a Stereo mix by an analogue matrix process. Dolby Pro Logic II material can be played back by normal Stereo equipment (as Stereo) or decoded into 5 channel surround-sound.

Dolby Pro Logic II is compatible with the earlier 4 channel (Left, Centre, Right and mono Surround) Dolby Pro Logic system (which was the decoding counterpart to Dolby Surround encoding) as used widely on Video tapes, TV broadcasts and earlier films.

Note: Pro Logic does not include a Low Frequency Effects channel for the Subwoofer, but the 650R can create a Subwoofer output (for 5.1) via Bass management. Refer to the 'Tone/Sub/LFE configuration' section in the 'Operating instructions' part of this manual.

DOLBY PRO LOGIC IIX | **Pro Logic IIX**

A newer version of Dolby Pro Logic II which is able to recreate 6 or 7 discrete surround sound channels (with fully stereo Back Surrounds in 7 channel mode) from suitable encoded stereo source material. Pro Logic IIX also has modes for post processing either Stereo material or 5.1 material into 6 or 7 channels whether or not it has been Pro Logic IIX encoded. When 5.1 decoding is required, Dolby Prologic II decoding will always be used by the 650R in place of Pro Logic IIX as IIX only works for 6 or 7 channel output.

Note: Pro Logic IIX does not include a Low Frequency Effects channel for the Subwoofer, but the 650R can create a Subwoofer output (for 6.1/7.1) via Bass management. Refer to the 'Tone/Sub/LFE configuration' section in the 'Operating instructions' part of this manual.

dts Neo:6 | **DTS Neo:6**

A DTS technology which is able to recreate 6 channel (Left Front, Right Front, Centre, Left Surround, Right Surround, Surround Back) surround sound from suitable analogue matrix encoded stereo source material. DTS Neo:6 material can be played back by normal Stereo equipment (as Stereo) or decoded into 6 channel surround-sound.

Note: Neo:6 does not include a Low Frequency Effects channel for the Subwoofer, but the 650R can create a Subwoofer output via Bass management. Refer to the 'Tone/Sub/LFE configuration' section in the 'Operating instructions' part of this manual.

DTS Neo:6 can also be decoded as 7.1 by sending the Surround Back decode to the both the Surround Back Left and Right speakers (forming two mono Back Surrounds).

dts Digital Surround | 96/24 | **DTS 96/24**

A DTS technology that provides 5.1 channels of 96kHz / 24bit audio (along with video if required) on DVD-Video and DVD-Audio (video zone) discs (when suitably encoded in DTS 96/24). DVD players which allow 'DTS digital out' pass the DTS 96/24 bitstream over S/PDIF for decoding in the 650R.

DSP modes

These modes allow a surround-sound experience from source material that has no encoding at all. The surround sound effect is achieved by Digital Signal Processing of the Analogue or Digital stereo source used. Five modes are possible: Movie, Music, Room, Theatre and Hall.

Stereo/Stereo + Sub

Only the Front Left and Front Right speakers (and subwoofer if selected) have output in this mode. If an analogue source is selected it will be converted to digital via 24 bit A/D converters to allow digital domain sub creation and bass/treble controls.

If a digital source is selected the 650R will be processing either LPCM stereo (from the digital outputs of a CD player for instance) or a Stereo downmix of DD or DTS material (from the digital output of a DVD player for instance).

Other modes

Analogue Stereo Direct

Selects the analogue inputs for the current source directly with no A/D conversion, DSP processing, Bass/Treble or subwoofer channel active. Provides the very best fidelity for analogue Hi-Fi source equipment. In this mode the 650R is acting just like a normal Hi-Fi integrated amplifier.

Multi Channel PCM

Some playback devices (in particular Blu-ray players) are able to decode some of the above formats themselves internally and then output the decoded audio as Multi Channel PCM to the 650R. In addition Blu-ray disks can support native unencoded Multi Channel PCM soundtracks (of up to 8 channels) on the disc itself. In either case if your player can output these over HDMI the 650R is able to receive them in Multi-Channel PCM mode.

Operating instructions

To activate the 650R, switch the Power button on the rear panel to *On* then press the *Standby/On* button on the front panel.

Selecting the source

1. Select the desired source by pushing the corresponding source button on the front panel or remote control.

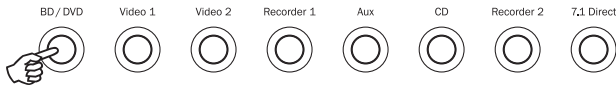

2. If necessary, press the *Audio Input Type* button to select the input mode of the source equipment, either analogue, digital or HDMI (depending on the connection made on the rear panel).

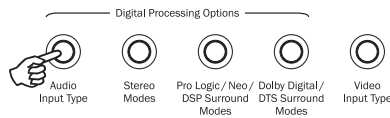

The digital, analogue or HDMI icons on the display show which is the currently selected input type.

Note: The 650R stores the input type for each source so that it is automatically recalled when that source is selected again.

Selecting the desired listening mode

Select an appropriate mode for the source material/type you are listening to by pressing one of the 3 main Digital Processing Options buttons and cycling through sub-modes where available.

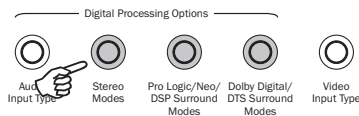

In all cases the first time a mode button is pressed the 650R will report the current decoding mode on the front panel display. Pressing the button again will then cycle to the next available mode (if there is one). If no button is pressed for 4 or 5 seconds the 650R returns to normal operation without changing mode.

Stereo Modes - Selects 2 channel Stereo operation for stereo material, pressing again selects Stereo + Sub mode.

This is a digitally processed mode that allows bass and treble controls, and sub generation if required. The input can be either analogue (in which case it will be turned into digital by 24 bit A/D conversion) or natively digital.

Prologic/Neo:6/DSP modes - Selects a range of surround modes with appropriate matrix encoded material.

These modes are for use with the analogue or digital outputs from TV's or VCR Players for instance if the source material has been encoded using one of these processes.

ProLogic and Neo:6 are both available in various guises to decode appropriately encoded soundtracks. Additionally DSP modes are available to process sources with no encoding at all. Due to the matrix encoding process none of these modes incorporate flags that tell the 650R the type of encoding used in the source material. Thus you must manually select these modes.

Dolby Digital/DTS Modes - Selects a range of digital surround modes with the appropriately digitally encoded material (only). These modes are for use with the SPDIF, Toslink or HDMI digital outputs (set to Bitstream/Raw) from Blu-ray players, DVD players or satellite receivers etc. In order for the 650R to allow selection of these modes a valid input digital bitstream must be present. This is because the 650R needs to read the incoming flags in order to determine the type of decoding which can be used and present any options that might be possible.

Note: Some new Surround Sound types (such as the Dolby and DTS HD) are available only from Blu-ray disc over HDMI.

If no bitstream is present, pressing this button will result in the 650R displaying "Mode Unavailable".

Note: The modes available for each button depend both on the Speaker Configuration that has previously been set in the OSD and on the source material.

Pressing DD/DTS Modes button will cause the 650R to lock onto the incoming bitstream and select the first available mode for the current bitstream type.

In some circumstances (see tables) pressing the button again will switch to an alternative decoding option.

Pressing the Prologic/ Neo:6/DSP modes button when the 650R has locked to a DD/DTS bitstream will present more options where possible including Post-Processed modes.

These are modes that allow extra processing to be applied after the main surround-sound decoding. For instance Dolby Digital (2/0) + PLII Music. Which adds a 5.1 ProLogic decode to a Stereo Dolby Digital decode to turn 2 channel stereo into 5.1.

This mode would be accessed by first selecting the Dolby Digital/DTS Mode button with a Dolby (2/0) bitstream present (selects a normal Dolby Digital (2/0) decode. Now press the Pro Logic/ Neo:6/DSP mode button to access the next mode which adds a PLII decode on top.

For 6.1 or 7.1 Speaker setups, the number of decoding possibilities increases as shown in the following 'Decode modes' tables. Several extra Post Processing modes are available using either Prologic IIx or Neo:6.

Incoming Dolby Digital/DTS streams are always shown on the front panel display as Dolby Digital (x/x).x or DTS (x/x).x, where the bracketed numbers indicate the active channels in the source material. Active output channels are shown by the icons on the right hand side of the front panel display. Possible incoming DD/DTS types are:

- (1/0) - Mono, Centre channel only
- (2/0) - Left/Right stereo
- (2/0).1 - Left/Right stereo and LFE (Sub)
- (2/2) - Left/Right stereo and Left/Right surround
- (3/0) - Left, Centre, Right
- (3/0).1 - Left, Centre, Right and LFE (Sub)
- (3/2).1 - 5.1: Left, Right, Centre, Left Surround, Right Surround and LFE (Sub)
- (3/3).1 - 6.1: Left, Right, Centre, Left Surround, Right Surround, Surround Back and LFE (Sub)
- (3/4).1 - 7.1: Left, Right, Centre, Left Surround, Right Surround, Surround Back Left, Surround Back Right and LFE (Sub)

Decode modes - 5.1 speaker setup



Pro Logic/Neo/
DSP Surround
Modes



Dolby Digital/
DTS Surround
Modes

Incoming audio format	Native channel resolution	Modes available	Output channels	Modes available	Output channels
PCM	2	PCM + PLII Movie PCM + PLII Music PCM + PLII Game PCM + Neo:6 Cinema PCM + Neo:6 Music Movie Music Room Theatre Hall	>5.1 >5.1 >5.1 >5.1 >5.1 >5.1 ■ >5.1 ■ >5.1 ■ >5.1 ■ >5.1 ■	PCM	2 ◆
Dolby Digital (2/0)	2	Dolby Digital (2/0) + PLII Movie Dolby Digital (2/0) + PLII Music Dolby Digital (2/0) + PLII Game	>5.1 >5.1 >5.1	Dolby Digital (2/0)	2
Dolby Digital	5.1			Dolby Digital (3/2).1	5.1
Dolby Digital EX	6.1			Dolby Digital EX (3/3).1	5.1<
DTS (2/0)	2			DTS (2/0)	2
DTS	5.1			DTS (3/2).1	5.1
DTS ES Matrix	6.1			DTS ES Matrix (3/3).1	5.1<
DTS ES Discrete	6.1			DTS ES Discrete (3/3).1	5.1<
DTS 96/24	5.1			DTS 96/24	5.1
Multi Channel PCM	5.1 ★			Multi PCM (3/2).1	5.1
Multi Channel PCM	7.1 ★			Multi PCM (3/4).1	5.1<
Dolby Digital Plus	5.1 ★			Dolby Digital Plus (3/2).1	5.1
Dolby Digital Plus	7.1 ★			Dolby Digital Plus (3/4).1	5.1<
Dolby True HD	5.1 ★			Dolby True HD (3/2).1	5.1 ▼
Dolby True HD	7.1 ★			Dolby True HD (3/4).1	5.1< ▼
DTS HD High Resolution 5.1 ★				DTS-HD HR (3/2).1	5.1
DTS HD High Resolution 7.1 ★				DTS-HD HR (3/4).1	5.1<
DTS Master Audio	5.1 ★			DTS-HD MA (3/2).1	5.1 ▼
DTS Master Audio	7.1 ★			DTS-HD MA (3/4).1	5.1< ▼

Key (all tables)

- 5.1< Indicates a 5.1 decode of 6.1 or 7.1 material (phantom back centre).
- 6.1< Indicates a 6.1 decode of 7.1 material (SBL/SBR mixed to mono and output as SB).
- >5.1 Indicates a 5.1 output created by a 2.0 decode post processed to 5.1.
- >6.1 Indicates 6.1 output created by a 2.0 or 5.1 decode, post-processed to 6.1.
- >7.1 Indicates 7.1 output created by a 2.0 or 5.1 decode, post-processed to 7.1.
- 7.1 Upmix of 5.1 material, Left and Right Surrounds mixed to both Left and Right Surrounds and Left and Right Rear Surrounds.
- ▲ 7.1 'upmix' of 6.1 material. Center back surround channel played back via two mono rear surrounds. Acoustically this is actually a native format presentation.

- ◆ Stereo or Stereo + Sub, Press Stereo Modes Button to change.
- Digital Signal Processing created modes for signals with no encoding.
- ★ Available via HDMI inputs only.
- ▼ Lossless encoded format.

Note: Bold entries are being output in their native resolution/format.

In all cases, pressing the Stereo Modes button always cycles round:

Stereo Modes	Output channels
Stereo	2
Stereo + Sub	2.1

Either native Stereo or downmix of DD/DTS 5.1/6.1/7.1 etc.

Pressing a mode button will first cause the 650R to scroll the current decode mode across the front panel display. Pressing the mode button again whilst text is scrolling on the display or within 4 seconds of it finishing will select and display the next available mode.

Decode modes - 6.1 speaker setup



Pro Logic/Neo/
DSP Surround
Modes



Dolby Digital/
DTS Surround
Modes

Incoming audio format	Native channel resolution	Modes available	Output channels	Modes available	Output channels
PCM	2	PCM + PLIIx Movie PCM + PLIIx Music PCM + PLIIx Game PCM + Neo:6 Cinema PCM + Neo:6 Music Movie Music Room Theatre Hall	>6.1 >6.1 >6.1 >6.1 >6.1 >6.1 ■ >6.1 ■ >6.1 ■ >6.1 ■ >6.1 ■	PCM	2 ◆
Dolby Digital (2/0)	2	Dolby Digital (2/0) + PLIIx Movie Dolby Digital (2/0) + PLIIx Music Dolby Digital (2/0) + PLIIx Game	>6.1 >6.1 >6.1	Dolby Digital (2/0)	2
Dolby Digital	5.1	Dolby Digital (3/2) + PLIIx Movie Dolby Digital (3/2) + PLIIx Music	>6.1 >6.1	Dolby Digital (3/2).1 + EX Dolby Digital (3/2).1	>6.1 5.1
Dolby Digital EX	6.1	Dolby Digital (3/3) + PLIIx Movie Dolby Digital (3/3) + PLIIx Music	>6.1< >6.1<	Dolby Digital EX (3/3).1	6.1
DTS (2/0)	2	DTS (2/0) + PLIIx Movie DTS (2/0) + PLIIx Music DTS (2/0) + Neo:6 Cinema DTS (2/0) + Neo:6 Music	>6.1 >6.1 >6.1 >6.1	DTS (2/0)	2
DTS	5.1	DTS (3/2) + PLIIx Movie DTS (3/2) + PLIIx Music DTS (3/2) + Neo:6 Cinema DTS (3/2) + Neo:6 Music	>6.1 >6.1 >6.1 >6.1	DTS (3/2).1 + ES Matrix DTS (3/2).1	>6.1 5.1
DTS ES Matrix	6.1	DTS ES Matrix (3/3) + PLIIx Movie DTS ES Matrix (3/3) + PLIIx Music DTS ES Matrix (3/3) + Neo:6 Cinema DTS ES Matrix (3/3) + Neo:6 Music	>6.1< >6.1< >6.1< >6.1<	DTS ES Matrix (3/3).1	6.1
DTS ES Discrete	6.1	DTS ES Discrete (3/3) + PLIIx Movie DTS ES Discrete (3/3) + PLIIx Music DTS ES Discrete (3/3) + Neo:6 Cinema DTS ES Discrete (3/3) + Neo:6 Music	>6.1< >6.1< >6.1< >6.1<	DTS ES Discrete (3/3).1	6.1
DTS 96/24	5.1	DTS 96/24 (3/2) + PLIIx Movie DTS 96/24 (3/2) + PLIIx Music DTS 96/24 (3/2) + Neo:6 Cinema DTS 96/24 (3/2) + Neo:6 Music	>6.1 >6.1 >6.1 >6.1	DTS 96/24 + ES Matrix DTS 96/24	>6.1 5.1
Multi Channel PCM	5.1 ★	Multi PCM (3/2).1 + PLIIx Movie Multi PCM (3/2).1 + PLIIx Music	>6.1 >6.1	Multi PCM (3/2).1	5.1
Multi Channel PCM	7.1 ★			Multi PCM (3/4).1	6.1<
Dolby Digital Plus	5.1 ★			Dolby Digital Plus (3/2).1	5.1
Dolby Digital Plus	7.1 ★			Dolby Digital Plus (3/4).1	6.1<
Dolby True HD	5.1 ★			Dolby True HD (3/2)	5.1 ▼
Dolby True HD	7.1 ★			Dolby True HD (3/4).1	6.1< ▼
DTS HD High Resolution 5.1 ★				DTS-HD HR (3/2).1	5.1
DTS HD High Resolution 7.1 ★				DTS-HD HR (3/4).1	6.1<
DTS HD Master Audio	5.1 ★			DTS-HD MA (3/2).1	5.1 ▼
DTS HD Master Audio	7.1 ★			DTS-HD MA (3/4).1	6.1< ▼

Decode modes - 7.1 speaker setup



Pro Logic/Neo/
DSP Surround
Modes



Dolby Digital/
DTS Surround
Modes

Incoming audio format	Native channel resolution	Modes available	Output channels	Modes available	Output channels
PCM	2 When the source has been appropriately encoded PLII gives 5 channel, Neo:6 6 channel and PLIIX 2 channel matrix encoding	PCM + PLIIX Movie PCM + PLIIX Music PCM + PLIIX Game PCM + Neo:6 Cinema PCM + Neo:6 Music Movie Music Room Theatre Hall	>7.1 >7.1 >7.1 >7.1 >7.1 >7.1 ■ >7.1 ■ >7.1 ■ >7.1 ■ >7.1 ■	PCM	2 ◆
Dolby Digital (2/0)	2	Dolby Digital (2/0) + PLIIX Movie Dolby Digital (2/0) + PLIIX Music Dolby Digital (2/0) + PLIIX Game	>7.1 >7.1 >7.1	Dolby Digital (2/0)	2
Dolby Digital	5.1	Dolby Digital (3/2).1 + PLIIX Movie Dolby Digital (3/2).1 + PLIIX Music	>7.1 >7.1	Dolby Digital (3/2).1 + EX Dolby Digital (3/2).1	>7.1 5.1
Dolby Digital EX	6.1	Dolby Digital (3/3).1 + PLIIX Movie Dolby Digital (3/3).1 + PLIIX Music	>7.1 >7.1	Dolby Digital EX (3/3).1 Upmix	7.1 ▲
DTS (2/0)	2	DTS (2/0) + PLIIX Movie DTS (2/0) + PLIIX Music DTS (2/0) + Neo:6 Cinema DTS (2/0) + Neo:6 Music	>7.1 >7.1 >7.1 ▲ >7.1 ▲	DTS (2/0)	2
DTS	5.1	DTS (3/2).1 + PLIIX Movie DTS (3/2).1 + PLIIX Music DTS (3/2).1 + Neo:6 Cinema DTS (3/2).1 + Neo:6 Music	>7.1 >7.1 >7.1 ▲ >7.1 ▲	DTS (3/2).1 Upmix DTS (3/2).1	>7.1 ● 5.1
DTS ES Matrix	6.1	DTS ES Matrix (3/3).1 + PLIIX Movie DTS ES Matrix (3/3).1 + PLIIX Music DTS ES Matrix (3/3).1 + Neo:6 Cinema DTS ES Matrix (3/3).1 + Neo:6 Music	>7.1 >7.1 >7.1 ▲ >7.1 ▲	DTS ES Matrix (3/3).1 Upmix	7.1 ▲
DTS ES Discrete	6.1	DTS ES Discrete (3/3) + PLIIX Movie DTS ES Discrete (3/3) + PLIIX Music DTS ES Discrete (3/3) + Neo:6 Cinema DTS ES Discrete (3/3) + Neo:6 Music	>7.1 >7.1 >7.1 ▲ >7.1 ▲	DTS ES Discrete (3/3).1 Upmix	7.1 ▲
DTS 96/24	5.1	DTS 96/24 (3/2).1 + PLIIX Movie DTS 96/24 (3/2).1 + PLIIX Music DTS 96/24 (3/2).1 + Neo:6 Cinema DTS 96/24 (3/2).1 + Neo:6 Music	>7.1 >7.1 >7.1 >7.1	DTS 96/24 Upmix DTS 96/24	>7.1 5.1
Multi Channel PCM	5.1 ★	Multi PCM (3/2).1 + PLIIX Movie Multi PCM (3/2).1 + PLIIX Music	>7.1 >7.1	Multi PCM 3/2.1	5.1
Multi Channel PCM	7.1 ★			Multi PCM 3/4.1	7.1
Dolby Digital Plus	5.1 ★	Dolby Digital Plus (3/2).1 + PLIIX Movie Dolby Digital Plus (3/2).1 + PLIIX Music	>7.1 >7.1	Dolby Digital Plus (3/2).1 Upmix Dolby Digital Plus (3/2).1	>7.1 ● 5.1
Dolby Digital Plus	7.1 ★			Dolby Digital Plus (3/4).1	7.1
Dolby True HD	5.1 ★	Dolby True HD (3/2).1* + PLIIX Movie Dolby True HD (3/2).1* + PLIIX Music	>7.1 >7.1	Dolby True HD (3/2).1 Upmix Dolby True HD (3/2).1	>7.1 ▼ ● 5.1 ▼
Dolby True HD	7.1 ★			Dolby True HD (3/4).1	7.1 ▼
DTS HD High Resolution 5.1 ★				DTS-HD HR (3/2).1 Upmix DTS-HD HR (3/2).1	>7.1 ● 5.1
DTS HD High Resolution 7.1 ★				DTS-HD HR (3/4).1	7.1
DTS HD Master Audio	5.1 ★			DTS-HD MA (3/2).1 Upmix DTS-HD MA (3/2).1	>7.1 ▼ ● 5.1 ▼
DTS HD Master Audio	7.1 ★			DTS-HD MA (3/4).1	7.1 ▼

* <=96kHz

Operating instructions continued

Dynamic range control

This setting controls the dynamic range of Dolby Digital movie soundtracks by compressing the audio to limit the difference in level between loud and quiet passages in the movie.

This can be a useful feature when watching movies late at night for instance. Three settings are possible:

Auto - Compression is always applied for Dolby Digital and Dolby Digital Plus soundtracks. The application and amount of compression to Dolby True HD soundtracks is dictated by the soundtrack itself.

Off - No Compression (normal full dynamic range playback)

On - Compression is always applied for all Dolby soundtracks (reduced dynamic range playback)

DRC can be accessed by the Dynamic button on the remote, the current setting is displayed, pressing the button again moves to the next setting. When finished make no adjustment for a few seconds and the 650R will save the settings and exit the menu.

Advanced Dolby/DTS adjustments

The first three adjustments affect Dolby Prologic II or IIx processing (or post-processing) in Music mode only. Movie and Game modes where available are preset as part of their specification to match the encoding or provide a specific effect. These adjustments have no affect in these modes.

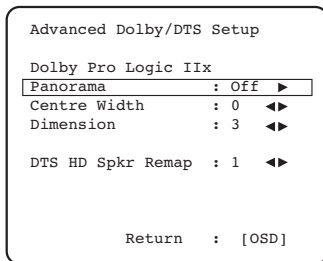

Panorama mode - A Prologic II/IIx mode that extends the front Stereo image to the surround sound speakers for a more enveloping experience. This mode can be either On or Off.

Centre Width - Allows gradual adjustment of the centre image from being produced only by the Centre speaker (Setting 0) through levels of being spread between the centre channel and Left and Right speakers to finally being produced by the Front Left and Right speakers only (Phantom Centre, Setting 7). Useful in optimising the Front/Centre/Right soundfield for best integration of the 3 speakers. Best tuned by ear.

Dimension - Adjusts the soundfield to be gradually shifted from the front of the room to the back to suit taste, speaker positioning and size of room. Setting 0 has the image furthest forward, 6 furthest back.

All three adjustments are a matter of personal preference, experiment for the settings that you prefer when you are using PLII or PLIIx decoding.

DTS-HD speaker re-map

As there is no "official" speaker layout for discrete 7.1 channel audio it could be possible that the original master track of a 7.1 soundtrack was mastered with a different speaker layout than the one being used in your home. DTS have addressed this issue for DTS-HD Master Audio and High Resolution Audio by including in the bitstream flags to tell the receiving AV Receiver which of a 7 nominal 7.1 speaker layouts was actually used. By using special DTS Speaker Remap algorithms the 650R is able to electronically "reposition" the speakers (i.e. direct the audio propagation), so that the playback matches the original encoded layout for the best possible sound quality.

A second aim of this technology is that by re-purposing some of the 7.1 available channels it is possible to use some of them to do new things such as adding a height element to the sound field.

The following diagrams show the 7 possible **encoding** schemes for reference.

The angles quoted refer to the angle from a nominal 0 degrees line through the centre channel to each speaker either side right or left of that line.

Configurations 1 and 5 are variants of normal 7.1 setups whilst Configuration 6 can increase the available panning of the front channels.

Configurations 2,3,4 and 7 are less conventional and re-purpose some of the available 7.1 channels to provide an extra height dimension to the sound field in different ways. Please refer to the DTS website for more details on this new technology.

Configuration 1 - 7.1 channel: L, C, R, LFE, Lss, Rss, Lsr, Rsr

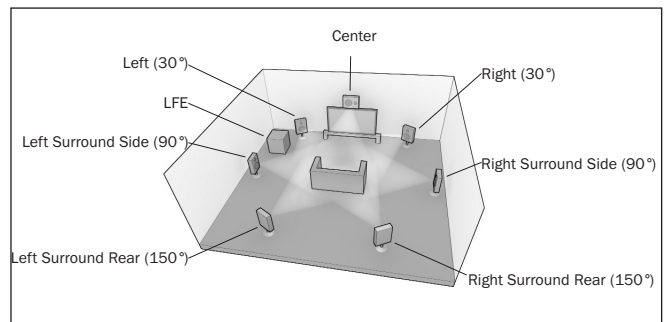

Configuration 2 - 7.1 channel: L, C, R, LFE, Ls, Rs, Lhs, Rhs

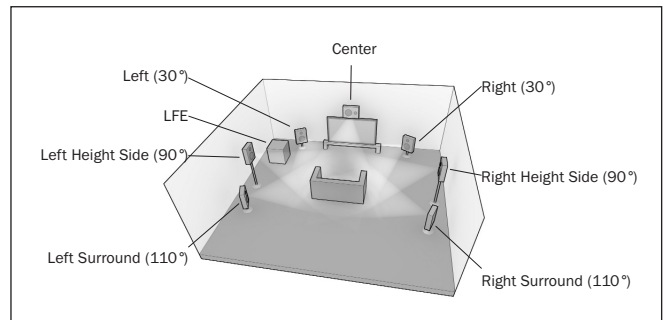

Configuration 3 - 7.1 channel: L, C, R, LFE, Ls, Rs, Cs, Oh

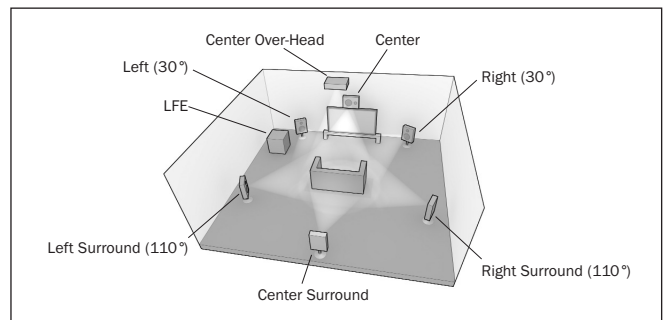

Configuration 4 - 7.1 channel: L, C, R, LFE, Ls, Rs, Lh, Rh

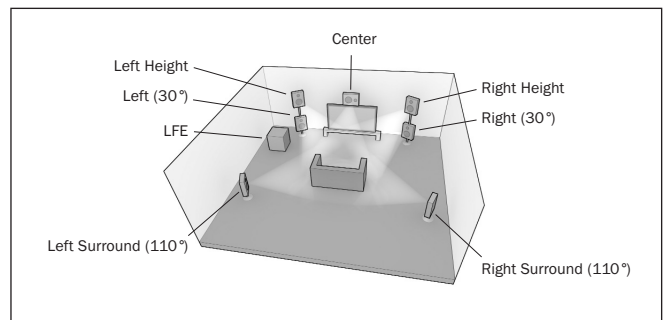

Configuration 5 - 7.1 channel: L, C, R, LFE, Ls, Rs, Lsr, Rsr

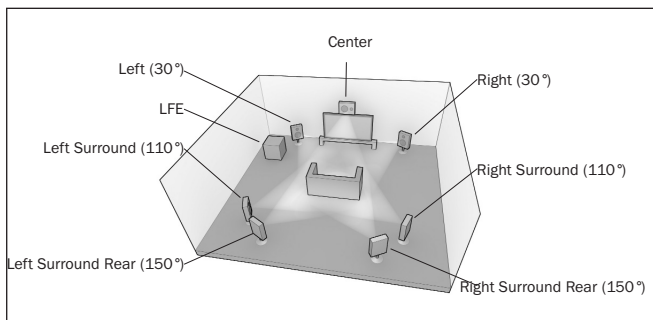

Configuration 6 - 7.1 channel: L, C, R, LFE, Ls, Rs, Lw, Rw

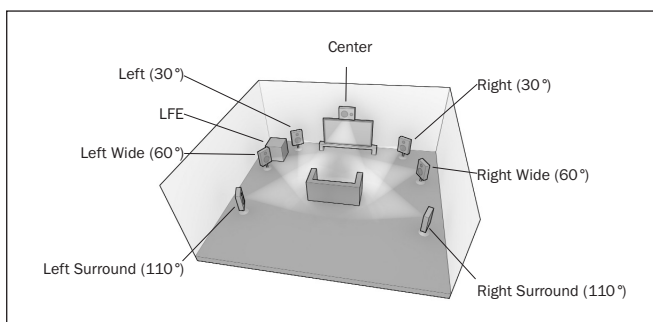

Configuration 7 - 7.1 channel: L, C, R, LFE, Ls, Rs, Ch, Cs

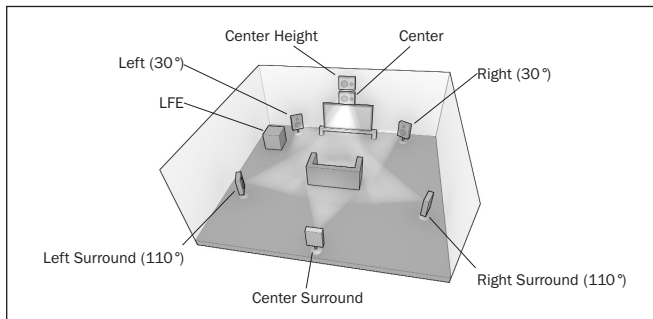

For **playback** the 650R expects you to have an actual physical speaker setup approximately conforming to one of the layouts as shown below.

5.1

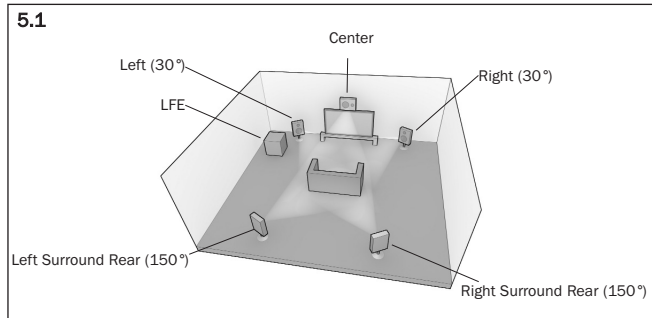

6.1

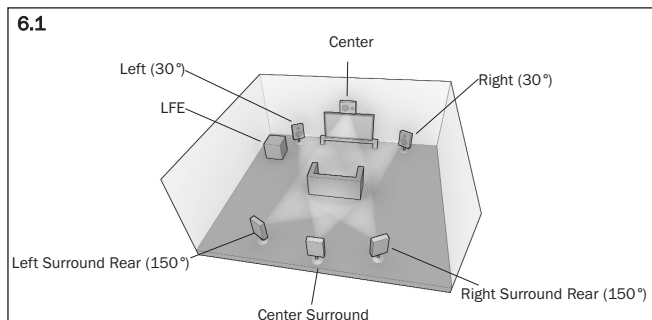

7.1

Configuration 1

or Configuration 5

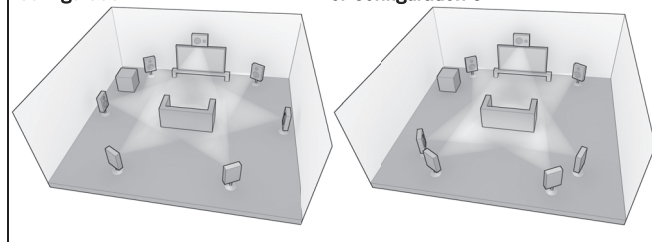

For 5.1/6.1 setups the situation is simple, the 650R automatically performs any DTS Speaker Remapping required, mapping any of the 7 incoming possibilities to these 5.1 or 6.1 configurations. All you need to do is make sure you have correctly selected a 5.1 or 6.1 Decoding Mode in the Speaker Setup menu. No other adjustments are necessary.

For 7.1 there are two alternative speaker setup you might have. These corresponds to configuration 1 and configuration 5 as above.

Here you need to tell the 650R which configuration best matches your speaker setup by selecting the DTS-HD speaker menu and selecting the 1 or 5 option.

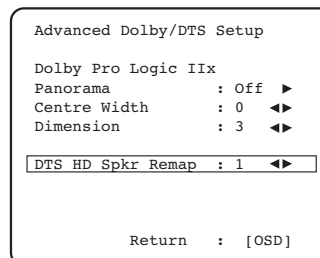

The 650R can then perform any speaker re-mapping required automatically, and maps any of the incoming 7 possibilities to whichever one of the two 7.1 possibilities you have.

Note: This feature by its nature only works for 7.1 DTS HD Master Audio or DTS HD High Resolution Audio bitstreams.

Also note that where the incoming speaker configuration and your physical speaker configuration actually match the 650R performs no mapping as you'd expect.

Operating instructions continued

Using the Tuner

1. Press the *Tuner FM/AM* button on the front panel or remote control to select Tuner mode.
2. Press the *Tuner FM/AM* button again to select FM or AM if desired.
3. Press the *Mode/Store* button on the front panel (or *Mode* button on the remote control) to select automatic tuning, manual tuning or preset mode.
4. Press the *Tuning +* and *Tuning -* buttons (or the left and right arrow buttons on the remote) to select the station you want to listen to.

In automatic tuning mode the unit scans to the next strong station. In manual tuning mode the user can step manually through the frequencies. In preset mode the unit cycles through the presets only.

Two FM modes are available, stereo and mono - Press the *Stereo Mono* button on the remote to alternate between Stereo mode and Mono mode. If the *Display* button is pressed, the RDS station names of FM stations will be displayed if available.

Storing stations

1. Tune in a station you wish to store as explained previously.
2. Press and hold the *Mode/Store* button (or *Mode* button on the remote) for 5 seconds to bring up the "MEM" icon.
3. Use the *Tuning+/-* buttons to select a preset station number (1-15). The station number will be displayed on the screen.
4. Press the *Mode/Store* button (or *Mode* button on the remote) to memorise, while the "MEM" icon is still flashing.

Radio Data Systems (RDS)

RDS is a method for the transmission of additional information from local radio stations. It is only available in FM mode. RDS will only work if the local broadcasting stations have RDS transmission and the signal is strong enough.

Press the *Display* button on the remote and go through the displayed functions. There are functions for PS, PTY, CT and RT:

PS (Station Name) - current station name will be shown

PTY (Program Type) - current name type of the program will be shown

CT (Clock/Time) - current time from Radio Station will be displayed.

Note: Clock/Time will be only transmitted from local radio station once a minute. If the Clock - Time is not available the message "NO CT" will appear briefly on the display.

RT (Radiotext) - some Text messages will be shown.

Program Type Search (PTY)

1. Press the *PTY* button on remote control, "PTY SELECT" will flash on the display.
2. Press *Tuning + / -* to choose the program type, for example NEWS or SPORT.
3. Press the *PTY* button again once you have chosen the program type.

When the selected type of program is tuned in, it will stop searching, otherwise, PTY Search will timeout after approximately 30 seconds.

Auto Program Search (APS)

1. Press the *Tuner FM/AM* button to select the AM or FM band.
2. Press the *APS* button on the remote to begin the automatic program search through available stations. The searched stations will be memorised in the respective band memory (maximum of 15 stations).

Audio split mode

In some circumstances the 650R is able to allow the user to view one source whilst listening to another. For instance you could watch the video of a sports channel whilst getting an audio commentary from another such as the Tuner. Because the audio and video portions of an HDMI signal are interlinked there are however some limitations.

From HDMI sources the only audio you can split to is the Tuner. From Analogue video sources you can split to any Source that has Analogue or Digital (SPDIF/TOSlink) set as its Audio Input Type. For example, if Video 1 is assigned a component video input type, you can watch Video 1 whilst splitting the audio to the CD input.

You cannot split to or from sources that have HDMI set as their Audio or Video Input Type. For example, if Video 1 is assigned an HDMI audio or video input type, you cannot watch Video 1 whilst splitting the audio to the CD input.

To perform Audio Split:

1. Select the source you wish to watch in the normal way.
2. Press and hold the button for the source you wish to listen to. After 4 seconds approx "Audio Split" will scroll across the display and you will now be listening to that source instead. Video will not have changed.

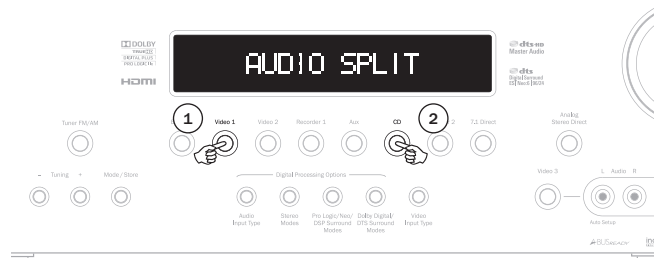

If the combination is not allowed "Mode Unavailable" will instead scroll across the display and no change will be made.

To cancel audio split mode simply select a new source and normal operation will be resumed.

Recorder 1/2

Recorder 1 as well as having various video and audio inputs has recording outputs for Composite video, S-Video, digital audio and analogue audio. Whatever source is selected for viewing/listening via the main outputs will also be automatically sent to the Recorder 1 outputs for recording purposes. Recorder 1 would typically be used for a DVD-R/RW, VCR or other device with audio and video recording capability.

Recorder 2 has analogue and digital audio outputs only. Additionally the Recorder 2 outputs are completely independent from the main listening and Recorder 1 outputs and are separately set in the OSD.

This means it's possible to watch (and optionally record via Rec 1) one source whilst recording another source via Rec 2. Recorder 2 would typically be used with a Tape/MD/CD-R machine with audio recording capability.

Select the 'Rec.2 Output Select' menu and press *Enter*. Use the *Left* and *Right* arrows to set the audio source for the Rec.2 Output:

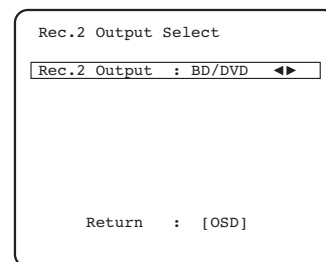

Sub crossovers and bass management

As covered in the '650R Setup' section the 650R performs bass management for any speaker that is set to 'Small' in the OSD. This means that bass for speakers that are unable to reproduce bass effectively is instead routed to the subwoofer.

Tone/Sub/LFE configuration

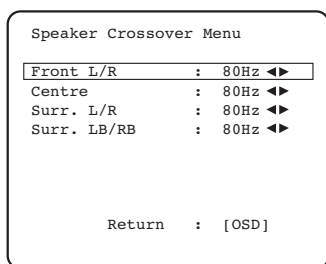

The crossover adjustments in the Speaker crossover menu are used to determine the point as which this transition is made. In other words they set the frequency below which bass is routed away from any 'Small' speakers and into the Subwoofer channel. It should be understood that bass sent to the subwoofer by bass management is different to bass encoded into the surround-sound material as a dedicated Low Frequency Effects channel.

If the source material contains a separate LFE channel (ie DD or DTS material) this is always routed to the subwoofer (if it is On) and is not affected by the crossover setting. Some encoding types (Such as Dolby PLII/Ilx and Neo:6) do not actually have a LFE channel.

The default setting for all bass management crossovers is 80Hz and is a good global starting point. If you do not wish to make any adjustments simply leave all crossovers at this default setting.

Note: These settings are actually only used for speakers that have been set to Small in the Speaker Configuration Menu.

For advanced users it is however possible to adjust the speaker crossovers used for any speakers set as 'Small' independently to allow for the fact that you may wish to direct bass away from front floorstanding speakers (and to the Subwoofer) at perhaps 50Hz but away from Surround Left and Rights at perhaps 100Hz. If you wish to make these adjustments it is best to consult your loudspeaker manufacturers documentation or contact your dealer to determine the frequency response of your system and where each speaker types bass response starts to tail off (often called the 3dB or 6dB roll off/cutoff point). This would be approximately the point the corresponding crossover should be set to.

Bi-amping

If you are running a 5.1 (or less) speaker setup only the 650R allows for bi-amping of the front left and right channels. It will be seen in the Speaker Configuration menu that with the Decode mode set as 5.1 a Bi-amp On/Off item appears.

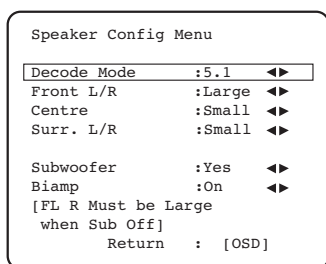

When selected, the 650R sends the front left and right signals to the SBL and SBR outputs as well.

In conjunction with bi-wireable/bi-ampable speakers this allows you to use two runs of speaker cable to each speaker with a dedicated amplifier channel for the bass and treble drivers of each speaker which can slightly increase the sound quality.

See diagram below of a bi-amped system (only front left and right speakers shown).

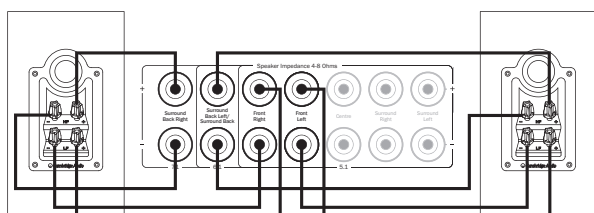

Note: Bi-wire links must be removed on the speaker's terminals.

Select the 'Tone/Sub/LFE' menu:

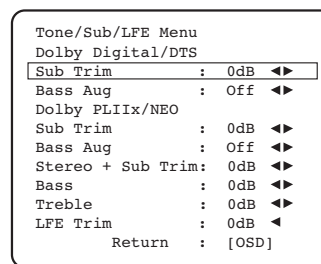

The Bass response can be adjusted +/- 10dB @ 100Hz (shelving). The Treble response can be adjusted +/-10dB @ 10kHz (shelving). The "Tone" icon will light up on the display if these controls are adjusted away from 0dB (flat). The Subwoofer crossover point can also be adjusted from 40 to 150Hz in 10Hz steps and also to 200Hz.

The 650R incorporates a couple of advanced Bass Management features. The overall Sub Level for DD/DTS modes, PLII/x/Neo:6 modes and Stereo + Sub mode can be set to different levels. This can be useful if you prefer to have a high level of Sub operation whilst watching movies but a lower level for music playback. The three levels are simply adjusted by up to +/-10dB in the OSD. The second feature is that the way Bass Management is applied can be changed.

In normal operation (Bass Augment Off) if the Front speakers are set to 'Small' (in the 'Speaker Config' menu) their bass is re-directed by high-pass filtering the Fronts and sending that bass to the Sub channel (i.e. bass is removed from the Fronts and sent to the Sub). If they are set to 'Large' no filtering takes place and no bass is sent from them to the Sub channel.

However with the Bass Augment function On and the Front speakers set to 'Large', bass from the Front Left and Right is now sent to the Sub channel without any filtering of the Front Left and Right taking place (i.e. these channels remain full range). In other words, the bass in the Sub channel is augmented by extra bass from the Front Left and Right channels. If the Front Left and Right are set 'Small', Bass Augment has no effect and operation is the same as for Bass Augment Off.

Bass Augment can be On or Off separately for DD/DTS or PLII/Ilx/Neo:6 operation.

There is no Bass Augment function for Stereo + Sub mode because in this mode if the Front speakers are set to 'Large' they will actually always be unfiltered.

Bass Augment can be a useful function with PLII/Ilx and Neo:6 material because these encoding types do not include an LFE Channel. This would normally mean that if all the speakers in your setup were set to 'Large', the subwoofer would in fact be inactive (as no bass has been re-directed plus there is no LFE channel). If it is desired to have the subwoofer running with all Large Speakers and these encoding types, enable Bass Augment for PLII/Neo6 and then set the Crossover points and levels by ear. A Sub channel will now be created from the Front Left and Right channels without filtering them. As with all adjustments it is a good idea to experiment to determine what works best with your particular setup.

Note: These adjustments work in all digitally processed Stereo or Surround modes but not in Analogue Stereo Direct or 7.1 Direct modes.

The LFE channel (for DD / DTS material) can also be trimmed by up to 10dB in 1dB steps useful for late night listening or other situations where it might be desired to reduce the low frequency effect level perhaps temporarily.

Remember the LFE is the Low Frequency Effects channel encoded into the disc and is different to the over all sub level which can include bass management from the other speakers.

Bass/Treble adjustments can also be made from the remote without entering the OSD by pressing the Bass/Treble button and then using the Vol Up/Down buttons.

Sub trim adjustments can also be made from the remote without the OSD by holding down the Sub On/Off button and using the Vol Up/Down buttons whilst it is kept down.

Operating instructions continued

Lip sync

The 650R can if required apply a small delay to the audio playback to resynchronise it to any video playback which appears to be behind the audio in time.

This can sometimes happen if the video is slightly delayed by a player or TV performing a lot of video processing.

Pressing the Lip Sync button on the remote will bring up the current Lip Sync value on the 650R's main display and allow adjustments in 10mS (10 thousandths of a second) increments.

Setting the Lip sync value to 0 causes Lip Sync delay to be turned off.

Note: The Lip sync value is stored and recalled separately for each source.

Input naming

If desired it is possible to customise the names shown on the front panel display for each source. Enter the OSD and select the 'Input Name Assign' menu. Use the *Left* and *Right* arrows to select the source you wish to edit (CD, BD/DVD etc) then press *Enter*:

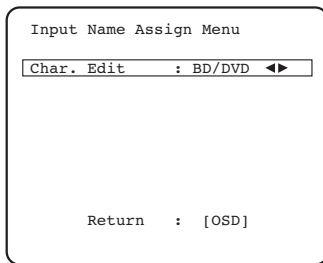

Use the *Vol Up*, *Vol Down*, *Left* and *Right* buttons to move around the character edit screen to select the required characters, press *enter* to move to the next character. Selecting the *<-* and *->* arrows at the bottom of the screen and pressing *Enter* also moves the currently edited character left or right.

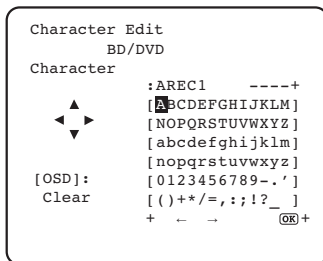

Once finished select 'OK' and press *Enter* to exit and save. Pressing the OSD button will exit the menu and discard any changes.

Note: The original names can be recalled by resetting the unit, see the Reset section at the end of this manual.

OSD setup

On-Screen Display is available on all video outputs.

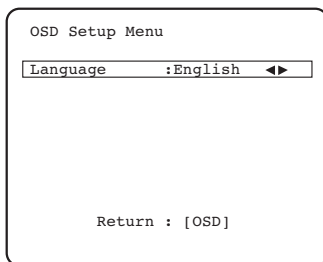

The OSD can be shown in several different languages. To change the OSD language highlight the 'Language' menu and use the *Left* and *Right* arrows to select between English, Dutch, French, German, Spanish, Italian, Norwegian, Swedish and Danish. Press the *OSD* button again to exit and save the options.

Custom installation (C.I.) use

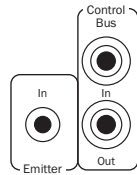

The 650R features Control Bus inputs and outputs that allow un-modulated remote control commands (positive logic, TTL level) to be received electrically by the unit. These control commands are typically generated by custom installation (multi-room) systems or remote IR receiver systems. The Control Bus sockets are colour-coded orange.

An IR Emitter Input is also provided that allows modulated IR remote control commands to be received electrically by the unit. Commands on this input operate the unit only and are not looped out demodulated on the Control Bus Output. An RS232C port is also featured which allows the 650R to be controlled by C.I. systems.



In addition the unit features 'direct' IR/Control codes as well as toggle codes for some of their features to simplify programming custom installation systems. Special direct On/Off and Mute commands can be accessed on the supplied remote control for teaching into C.I. systems as follows:

1. Press and hold the *Standby/On* button on the remote control. The remote first generates its standby (toggle) command. Keep the button held down, after 12 seconds an AV receiver "On" command will be generated. If the button is kept held down for a further 12 seconds, an AV receiver "Off" command is generated.

Repeat this procedure with the Mute, Sub On/Off, Stereo Mono and Tuner AM/FM buttons to send On/Off commands. The Tuner AM/FM button also provides unique FM and AM commands to allow switching to a specific band.

A full code table and RS232 protocol for this product is available on the Cambridge Audio website at www.cambridge-audio.com.

Reset/Back-up memory

The 650R has a function that preserves the preset memory and other settings. In the event of a power failure, or if the power cord of the unit is disconnected from the mains outlet, the back-up memory will preserve the preset memory for approximately one week. If the power supply is interrupted for 7 days or longer, the memory settings will be erased.

If it is desired to reset all settings to their factory defaults (or in the unlikely event that the unit locks up due to an electrical discharge etc), with the unit on and out of Standby mode press and hold the DVD and Analogue Stereo Direct buttons on the front panel for three seconds.

"RESET" will appear briefly on the front panel display before returning to Standby mode.

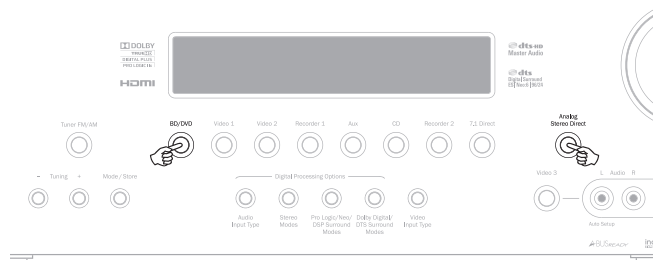

Multi-room connections

The 650R features Incognito Ready™ / A-BUS™ Ready outputs, allowing multi-room capability. One or two amplified keypads can be plugged into the 650R (using Cat5/5e cable and RJ45 plugs) to provide multi-room audio in one or two secondary rooms or zones. The keypads are powered by an external PSU (also required) through the Cat5/5e cables and no mains connection is required in the secondary rooms.

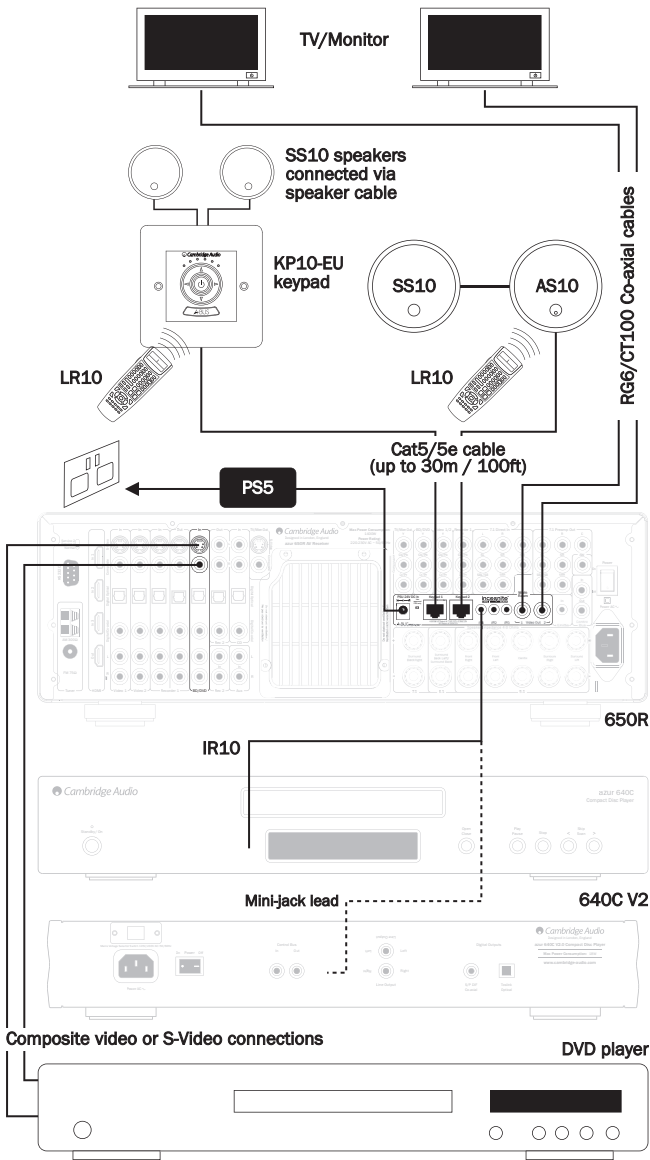

The 650R is Incognito Ready Type II, which means the keypads can operate independently of the amplifier in terms of volume/bass/treble etc, be independently turned on and off from the 650R and each other, and can also listen to a different source from that which is currently selected on the amplifier. However, both keypads can only listen to the same source.

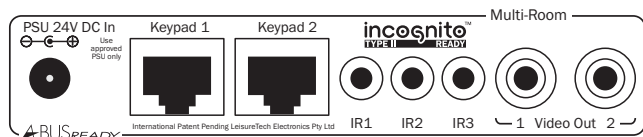

The 650R also features 2nd/3rd zone Composite video outputs which optionally allow the extra zones to have video capability. The 650R can use either Composite video, S-Video or component inputs as sources to supply the sub-zones, as it is able to transcode then to composite but not from HDMI sources. For HDMI sources, simply make an extra parallel analogue video connection to that sources input as well.

A-BUS is a standard that allows compatibility between different manufacturers equipment, so A-BUS compatible keypads from other manufacturers can also be used. If used with our own Incognito KP10 keypads, there are some extra features such as the ability to change source on the 650R from the keypad.

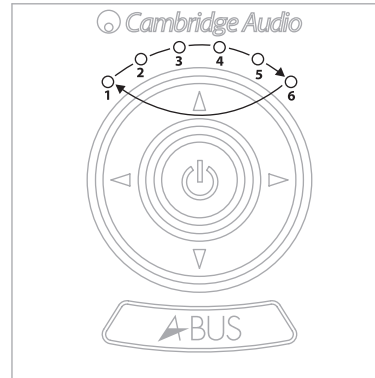

Order of selection:

1. Tuner
2. CD
3. BD/DVD
4. Video 1
5. Video 2
6. Rec 1

Local 1 - Aux*

Local 2 - Rec 2*

*Local source selection must be enabled on the keypad.

Connections to the 650R's Incognito Ready™ / A-BUS™ Ready outputs are made by Cat-5 cable (terminated with an RJ45 jack plug). The RJ45 plug must be wired to the EIA/TIA 568A wiring standard:

Wire colours:
1. Green/White
2. Green

3. Orange/White
4. Blue
5. Blue/White

6. Orange
7. Brown/White
8. Brown

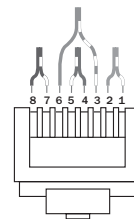

Plug view from contact end

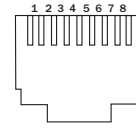

View into socket



Gather pairs, trim and insert into RJ45 plug

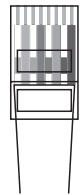

Crimp wires securely in place

To allow control of your source equipment from the remote rooms an IR emitter (IR10) is plugged into one of the IR outputs on the rear of the unit and then attached over the IR window of the source unit. Alternatively, on our own products that feature IR emitter Inputs, a mini-jack to mini-jack lead can be used. Commands received by the keypads can now be sent back to the source equipment via the 650R.

It is then possible to control the source equipment from the remote rooms by using the source equipment's own remote controls or through a learning remote. The Incognito LR10 can fully control the keypads, "learn" the source's remote control codes (including those from other manufacturers) and change source input on the 650R etc.

For further details on the Incognito multi-room system please contact your local Cambridge Audio dealer or visit www.cambridge-audio.com.

Troubleshooting

A low hum or buzz sound can be heard

Power cords or lighting placed near this product.

Analogue inputs not connected securely.

Sound is not audible from one channel

Speaker connections disconnected.

Speaker set to "None" in OSD setup menu.

Sound cuts off when listening to music or there is no sound even though power is ON

Speaker impedance is less than prescribed for the 650R.

The unit is not adequately ventilated and may be overheating.

Low bass or "phases" response

Speaker polarity (+/-) of one or more speakers is reversed.

An unusual hissing noise is heard when listening to a radio broadcast in stereo, but not heard when listening in mono

A slight noise may be heard because the method used for modulation of FM stereo broadcasts is different than that used for mono broadcasts.

Aerial quality also effects the level of hiss heard.

Noise is excessive in both stereo and monaural radio broadcasts

Poor location and/or direction of the antenna.

Transmitting station is too far away.

No sound from the rear speakers

Source being played is not recorded in surround sound.

Speaker/s set to "None" in OSD setup menu.

A stereo mode has been selected.

No sound from the centre speaker

Centre speaker has been set to "None" in OSD setup menu.

A stereo mode has been selected.

No sound from the subwoofer

Sub has been set to 'Off' in the OSD setup menu or via the remote.

DTS Neo:6, DD PLII/IIx modes (which have no LFE channel) have been selected with all speakers set to "Large".

Remote control is not working

The batteries are flat.

The remote is too far from the receiver or out of the effective range.

No sound from speakers when connected to a digital input

Audio input type is set to analogue (check display). Press the *Audio Input Type* button to switch to digital.

No sound from speakers when connected to an analogue input

Audio input type is set to digital. Press the *Audio Input Type* button to switch to analogue (check display).

Audio input type can also be set in the Input/Output Setup menu of the OSD.

No Sound from any speakers

Receiver is set for 'Pre-out' operation (See para 7.1).

By entering the OSD menu, selecting the input/output setup menu, the Preamp out setting can be changed from 'Normal' to 'Pre-out'. This disables the internal amplifiers when an external decoder amplifier is being used. Reset this to 'Normal' to restore sound.

No Sound from front speakers, but rear speakers work

Receiver is set for 'Ext 2Ch' operation (See para 7.1).

By entering the OSD menu, selecting the input/output setup menu, the Preamp out setting can be changed from 'normal' to 'Ext. 2 Ch'. This disables the internal amplifiers for the front channels when an external amplifier is being used to drive those channels. Reset this to 'Normal' to restore sound.

Maximum or Minimum (mute) volume level can no longer be achieved. (Display will not reach 0db or -89db)

If the front left and right channels are adjusted using the OSD Level Calibration (balance) settings up or down to provide an off-centre front sound stage the result is that the maximum and minimum volume setting (the setting and the db level displayed, not the actual amount of volume achievable) is naturally limited by the same degree. (A small red 'BAL' icon appears on the front panel display to show channel balance is now off-centre). For example, adjusting the right channel to +10db will mean that the maximum sound level is now reached when the display shows -10db (not 0db as expected). Readjust the front right and left levels back to 0db to restore full volume excursion.

Technical specifications

Audio

Power Output	2 x 120 watts rms per channel, 8 ohms (two channels driven)
	7 x 100 watts rms per channel, 8 ohms (all 7 channels driven)
THD	<0.006% @1kHz
Crosstalk	<-60dB @ 1kHz
Frequency response	10Hz - 20kHz -1dB
S/N Ratio	>90dB 'A' weighted
Audio Input Impedance / Sensitivity	47kOhms / 175mV or greater
Digital Input Impedance	75 ohms (Coaxial/SPDIF)
Tone Control	
- Bass	+/-10dB @ 100Hz
- Treble	+/-10dB @ 10kHz
Tuner	
- FM mode	87.5-108MHz, 75 ohm coaxial aerial
- AM mode	522-1629kHz, 300 ohm loop aerial

Video

Video Levels /Impedance	
- Composite (CVBS)	1Vp-p / 75 ohm
- S-Video (S-VHS)	Y 1Vp-p / 75 ohm C 0.286 Vp-p / 75 ohm
- Component	Y 1Vp-p / 75 ohm Cb/Cr 0.75Vp-p / 75 ohm Pb/Pr 0.75Vp-p / 75 ohm

HDMI

HDMI 1.3c
DVI 1.0
EIA/CEA - 861D
HDCP 1.1

HDMI version 1.3c with transfer of all video resolutions up to and including 1080p @ 24/25/30 fps (1920 x 1080) and deep colour supported, with HDCP handshaking.

All audio modes supported except reception of native Direct Stream Digital (DSD).

General

Architecture	Cirrus Logic CS43122 24 Bit 192kHz capable DAC for Front Left & Right
	Cirrus Logic CS52526 24 Bit 192kHz capable CODEC for surround channels + 24 Bit 2 channel A/D conversion
	Cirrus Logic CS497004 dual 32 bit DSP
Audio Inputs	8 Line Level Analogue Tuner (FM/AM) 7.1 Analogue Input 5 Digital Co-axial, 6 Digital Optical
Video Inputs	5 Composite, 5 S-Video, 3 Component Video, 3 HDMI
Main Audio Outputs	7 Amplified Speaker Outputs 7.1 Preamp outputs
Main Video Outputs	1 Composite, 1 S-Video, 1 Component Video, 1 HDMI
Recording Audio Outputs	2 Line Level Analogue 2 Digital Co-Axial, 2 Digital Optical
Recording Video Outputs	1 Composite, 1 S-Video
Other connections	1 1/4" / 6.35mm Headphone Output (32 To 600 ohms recommended) 1 Control Bus Input / Ouput 1 IR Emitter In 1 RS232C 1 IEC type mains inlet
Incognito Ready™ / A-BUS Ready™	2 A-BUS keypad outputs (2nd/3rd Zone) 3 IR Emitter outputs 2 Composite video outputs (2nd/3rd Zone) 1 External PSU input 24VDC
Standby power consumption	<1w
Quiescent power consumption	<70w
Max power consumption	1400w
Dimensions - H x W x D	150 x 430 x 420mm (inc all terminals & controls)
Weight	15kg (33lbs)

Cambridge Audio is a brand of Audio Partnership Plc
Registered Office: Gallery Court, Hankey Place
London SE1 4BB, United Kingdom
Registered in England No. 2953313

www.cambridge-audio.com

