

**Canon**

# Color imageRUNNER

C 3 3 8 0 / C 3 3 8 0 i  
C 2 8 8 0 / C 2 8 8 0 i

## Sending and Facsimile Guide

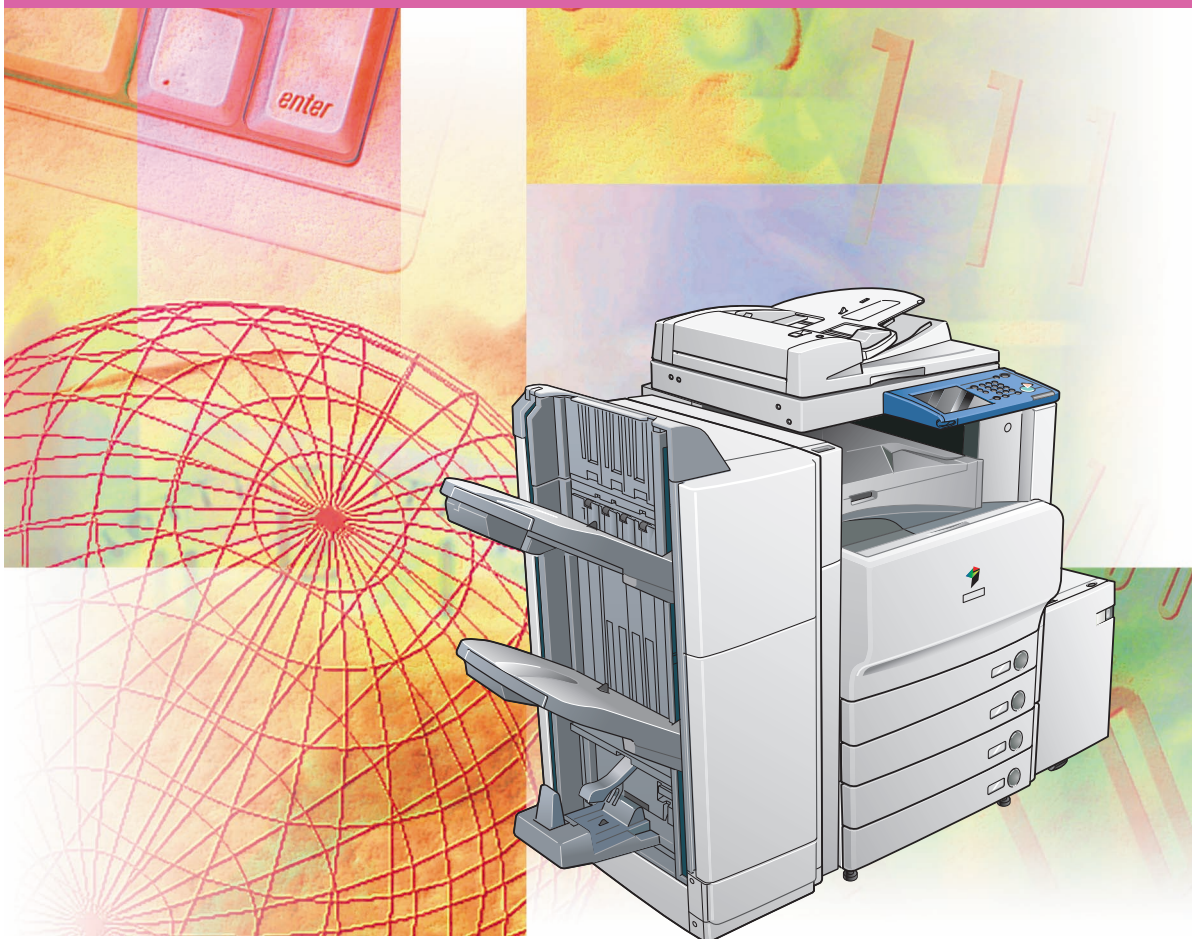

Please read this guide before operating this equipment.  
After you finish reading this guide, store it in a safe place for future reference.

**ENG**



**Color imageRUNNER**  
**C3380/C3380i**  
**C2880/C2880i**

**Sending and Facsimile**  
**Guide**



# Manuals for the Machine













The manuals for this machine are divided as follows. Please refer to them for detailed information. The manuals supplied with optional equipment are included in the list below. Depending on the system configuration and product purchased, some manuals may not be needed.



Guides with this symbol are printed manuals.



Guides with this symbol are included on the accompanying CD-ROM.  
(See footnote on the next page.)

<ul style="list-style-type: none"><li>• <b>Quick Reference for Basic Operations</b></li></ul>	<b>Easy Operation Guide</b>	
<ul style="list-style-type: none"><li>• <b>Learn How to Use Your Machine</b> The Tutorial CD is a teaching aid, designed to help you learn the various functions of the machine.</li></ul>	<b>Tutorial CD</b>	
<ul style="list-style-type: none"><li>• <b>Basic Operations</b></li><li>• <b>Troubleshooting</b></li></ul>	<b>Reference Guide</b>	 
<ul style="list-style-type: none"><li>• <b>Copying and Mail Box Instructions</b></li></ul>	<b>Copying and Mail Box Guide</b>	
<ul style="list-style-type: none"><li>• <b>Sending and Fax Instructions</b></li></ul>	<b>Sending and Facsimile Guide (This Document)</b>	
<ul style="list-style-type: none"><li>• <b>Setting Up the Network Connection and Installing the CD-ROM Software</b></li></ul>	<b>Network Quick Start Guide</b>	
<ul style="list-style-type: none"><li>• <b>Remote User Interface Instructions</b></li></ul>	<b>Remote UI Guide</b>	
<ul style="list-style-type: none"><li>• <b>Network Connectivity and Setup Instructions</b></li></ul>	<b>Network Guide</b>	
<ul style="list-style-type: none"><li>• <b>Color Network ScanGear Installation and Instructions</b></li></ul>	<b>Color Network ScanGear User's Guide</b>	
<ul style="list-style-type: none"><li>• <b>PS/PCL/UFR II Printer Instructions</b></li></ul>	<b>PS/PCL/UFR II Printer Guide</b>	
<ul style="list-style-type: none"><li>• <b>PCL Printer Driver Installation and Instructions</b></li></ul>	<b>PCL Driver Guide</b>	
<ul style="list-style-type: none"><li>• <b>PS Printer Driver Installation and Instructions</b></li></ul>	<b>PS Driver Guide</b>	



- **UFR II Printer Driver Installation and Instructions**

## **UFR II Driver Guide**



- **Mac OS X PS Printer Driver Installation and Instructions**

## **Mac PS Driver Guide**



- **Mac OS X UFR II Printer Driver Installation and Instructions**

## **Mac UFR II Driver Guide**



- **Fax Driver Installation and Instructions**

## **Fax Driver Guide**



- **Installing MEAP Applications and Using the Login Service**

## **MEAP SMS Administrator Guide**



- 
- To view the manual in PDF format, Adobe Reader/Acrobat Reader/Acrobat is required. If Adobe Reader/Acrobat Reader/Acrobat is not installed on your system, please download it from the Adobe Systems Incorporated website (<http://www.adobe.com>).
  - The machine illustration on the cover may differ slightly from your machine.



# How This Manual Is Organized

**Chapter 1** Introduction to Sending and Fax Functions

**Chapter 2** Basic Sending Methods

**Chapter 3** Basic Scanning Features

**Chapter 4** Special Scanning Features

**Chapter 5** Sending Documents

**Chapter 6** Receiving Documents

**Chapter 7** Special Fax Functions

**Chapter 8** Checking/Changing the Send/Receive Status

**Chapter 9** Customizing Communications Settings

**Chapter 10** Storing/Editing Address Book Settings

**Chapter 11** System Manager Settings

**Chapter 12** Printing Communication Reports

**Chapter 13** Troubleshooting

**Chapter 14** Appendix

Includes the report samples, glossary, specifications, and index.

# Contents

---

<b>Preface</b> .....	<b>xiii</b>
<b>How To Use This Manual.</b> .....	<b>xiii</b>
Symbols Used in This Manual .....	xiii
Keys Used in This Manual .....	xiv
Displays Used in This Manual .....	xiv
Illustrations Used in This Manual .....	.xv
Abbreviations Used in This Manual .....	.xv
<b>Legal Notices</b> .....	<b>xvi</b>
FCC (Federal Communications Commission) .....	xvi
Users in the U.S.A. ....	xvi
Users in Canada .....	xix
Utilisation au Canada. ....	.xx
Super G3 .....	.xxii
Trademarks .....	xxiii
Copyright .....	xxiii
Disclaimers .....	xxiv
<b>Important Safety Instructions.</b> .....	<b>xxv</b>
Telephone Equipment .....	.xxv

## **Chapter 1 Introduction to Sending and Fax Functions**

---

<b>What This Machine Can Do</b> .....	<b>1-2</b>
<b>Overview of the Color imageRUNNER C3380/C3380i/C2880/C2880i</b> .....	<b>1-6</b>
<b>Things You Must Do Before Using This Machine.</b> .....	<b>1-11</b>
Setting the Display Language .....	1-13
Selecting the Type of Telephone Line .....	1-14
Setting the Current Date and Time .....	1-14
Registering Your Machine's Fax Number. ....	1-16
Registering Sender Names .....	1-17
Registering the Unit's Name .....	1-18
<b>Flow of Sending Operations.</b> .....	<b>1-20</b>
<b>Sending Fax Documents Manually</b> .....	<b>1-31</b>
<b>Canceling a Job.</b> .....	<b>1-35</b>
Using the Touch Panel Display .....	1-35
Using the Stop Key .....	1-36
Using the System Monitor Screen .....	1-36

E-mail, I-Fax, Sending to a File Server, or Storing in a User Inbox. . . . .	1-36
Fax . . . . .	1-38

## **Chapter 2 Basic Sending Methods**

---

<b>Specifying Destinations Using the New Address Tab . . . . .</b>	<b>2-2</b>
Specifying a Fax Number . . . . .	2-2
Specifying an E-Mail Address . . . . .	2-6
Specifying an I-Fax Address . . . . .	2-7
Specifying a File Server . . . . .	2-11
Using the Keyboard . . . . .	2-12
Using the Browse Key (Windows (SMB)) . . . . .	2-14
Using the Browse Key (NetWare (IPX)) . . . . .	2-16
Using the Host Search Key (Windows (SMB)) . . . . .	2-19
Specifying a User Inbox . . . . .	2-20
Sending Documents to Yourself . . . . .	2-22
<b>Specifying Registered Destinations. . . . .</b>	<b>2-23</b>
Using the Address Book. . . . .	2-23
Using the One-Touch Buttons . . . . .	2-25
Using the Favorites Buttons . . . . .	2-26
Using a Server . . . . .	2-27
<b>Setting Cc and Bcc Addresses. . . . .</b>	<b>2-32</b>
<b>Checking/Changing a Destination . . . . .</b>	<b>2-34</b>
<b>Erasing a Destination . . . . .</b>	<b>2-36</b>
<b>Registering New Destinations Using the Register Key . . . . .</b>	<b>2-37</b>

## **Chapter 3 Basic Scanning Features**

---

<b>Selecting a Scan Mode . . . . .</b>	<b>3-2</b>
<b>Scan Settings . . . . .</b>	<b>3-4</b>
2-Sided Original . . . . .	3-4
Different Size Originals. . . . .	3-6
Document Size . . . . .	3-8
Specifying the Document Size . . . . .	3-8
Registering the Specified Document Size . . . . .	3-11
Resolution . . . . .	3-12
Scan Exposure and Original Type Settings . . . . .	3-13
Manual Exposure Adjustment . . . . .	3-13
Original Type Selection . . . . .	3-14
Automatic Exposure Adjustment . . . . .	3-16
Changing the Zoom Ratio . . . . .	3-17

Preset Zoom . . . . .	3-17
Zoom by Percentage . . . . .	3-19
Auto Zoom . . . . .	3-19
<b>Changing Color Modes . . . . .</b>	<b>3-21</b>

## **Chapter 4 Special Scanning Features**

---

<b>What are Special Features? . . . . .</b>	<b>4-2</b>
<b>2-Page Separation . . . . .</b>	<b>4-4</b>
<b>Frame Erase . . . . .</b>	<b>4-5</b>
Original Frame Erase . . . . .	4-6
Book Frame Erase . . . . .	4-7
Binding Erase . . . . .	4-9
<b>Job Build . . . . .</b>	<b>4-10</b>
<b>Adjusting the Contrast (Sharpness) . . . . .</b>	<b>4-13</b>
<b>Image Quality Adjustment . . . . .</b>	<b>4-14</b>
Remove Background . . . . .	4-14
Prevent Bleeding . . . . .	4-16
<b>User Preset Keys . . . . .</b>	<b>4-17</b>
Storing Scan Settings . . . . .	4-17
Naming a User Preset Key . . . . .	4-19
Erasing Scan Settings . . . . .	4-20

## **Chapter 5 Sending Documents**

---

<b>Sending Methods . . . . .</b>	<b>5-2</b>
Sending a Fax . . . . .	5-2
Sending an E-Mail Message . . . . .	5-5
Sending an I-Fax . . . . .	5-8
Sending a Job to a File Server . . . . .	5-10
Sending a Job to a User Inbox . . . . .	5-13
Delaying a Send Job . . . . .	5-14
Job Done Notice . . . . .	5-16
Previewing Originals . . . . .	5-17
Stamping Originals . . . . .	5-19
<b>Setting the File Format to Send a Document in . . . . .</b>	<b>5-21</b>
Setting the File Format . . . . .	5-22
Sending a Compact PDF . . . . .	5-25
Trace & Smooth . . . . .	5-27
Sending a Searchable PDF . . . . .	5-28
Encrypting PDF Files . . . . .	5-29

Adding a Digital Signature to a PDF .....	5-34
Adding a Device Signature .....	5-35
Adding a User Signature .....	5-36
<b>Job Recall .....</b>	<b>5-38</b>

## **Chapter 6 Receiving Documents**

---

<b>Receiving Print, Fax, and I-Fax Documents .....</b>	<b>6-2</b>
Receiving Documents .....	6-3
Processing Received Documents .....	6-5
Setting the Memory Lock Mode .....	6-7
Forwarding Received Documents .....	6-7
Erasing Received Documents .....	6-8
<b>Available Paper Sizes .....</b>	<b>6-10</b>

## **Chapter 7 Special Fax Functions**

---

<b>Sending with a Subaddress .....</b>	<b>7-2</b>
<b>Using a PIN Code .....</b>	<b>7-5</b>
Setting PIN Code Access .....	7-5
Dialing with a PIN Code .....	7-6
<b>Fax Information Services .....</b>	<b>7-8</b>

## **Chapter 8 Checking/Changing the Send/Receive Status**

---

<b>Checking/Changing the Status of Send Jobs .....</b>	<b>8-2</b>
Checking Send Job Details .....	8-2
Changing the Destination .....	8-5
Resending a Job .....	8-7
Printing the Send Job Status/Log .....	8-8
<b>Checking/Changing the Status of Fax Jobs .....</b>	<b>8-9</b>
Checking Fax Job Details .....	8-9
Printing the Fax Activity Report .....	8-11
<b>Checking/Changing the Status of Receive and Forwarded Jobs .....</b>	<b>8-12</b>
Checking Receive Job Details .....	8-12
Printing the Receive Job Log .....	8-13
Checking the Arrival of a Receive Job .....	8-13
Checking the Status of Jobs That Have Been Forwarded .....	8-14

## **Chapter 9 Customizing Communications Settings**

---

<b>What are Additional Functions? .....</b>	<b>9-3</b>
---	------------

<b>Communications Settings Table</b> .....	9-6
<b>Automatic Document Deletion</b> .....	9-10
<b>Data Compression Ratio for Color Send Jobs</b> .....	9-11
<b>Handling Documents That Fail to Be Forwarded</b> .....	9-12
<b>Number of Retry Attempts</b> .....	9-13
<b>Standard Send Settings</b> .....	9-14
<b>Favorites Buttons</b> .....	9-16
Registering a Favorites Button .....	9-16
Naming a Favorites Button .....	9-17
Registering a Comment for a Favorites Button .....	9-18
Erasing a Favorites Button .....	9-19
<b>Displaying Confirmation for Favorites Buttons</b> .....	9-20
<b>PDF Compression Priority</b> .....	9-21
<b>PDF (OCR) Mode</b> .....	9-23
<b>Confirming the Device Signature Certificate</b> .....	9-25
<b>Checking a User Signature Certificate</b> .....	9-26
<b>Initial Send Screen Display</b> .....	9-27
<b>Printing the TX Terminal ID</b> .....	9-28
<b>Dividing Data Into Chunks When Sending With WebDAV</b> .....	9-31
<b>Gamma Value for YCbCr Send Jobs</b> .....	9-32
<b>Initializing TX Settings</b> .....	9-33
<b>2-Sided Printing</b> .....	9-34
<b>Paper Drawer Selection</b> .....	9-35
<b>Reducing a Received Document</b> .....	9-37
<b>Printing Footer Information on a Received Document</b> .....	9-39
<b>2 On 1 Log</b> .....	9-40
<b>Gamma Value for YCbCr Received Jobs</b> .....	9-41
<b>Adjusting the Alarm and Monitor Volume</b> .....	9-42
<b>ECM Transmission</b> .....	9-43
<b>Pause Time</b> .....	9-44
<b>Auto Redial</b> .....	9-45
<b>Checking the Dial Tone before Sending</b> .....	9-47
<b>ECM Reception</b> .....	9-48
<b>Registering the Fax Number for an Additional Line</b> .....	9-49
<b>Registering the Unit Name for an Additional Line</b> .....	9-50
<b>Selecting the Telephone Line Type for an Additional Line</b> .....	9-51
<b>Selecting the Line for Sending</b> .....	9-52

## Chapter 10 Storing/Editing Address Book Settings

---

<b>Address Book Settings Table</b> .....	<b>10-2</b>
<b>About the Address Book</b> .....	<b>10-3</b>
<b>Storing New Addresses</b> .....	<b>10-5</b>
Fax Numbers .....	10-5
E-Mail Addresses .....	10-9
I-Fax Addresses .....	10-12
File Server Addresses .....	10-17
Group Addresses .....	10-19
Addresses Obtained via a Server .....	10-23
<b>Editing Address Details</b> .....	<b>10-30</b>
<b>Erasing Addresses</b> .....	<b>10-33</b>
<b>Naming an Address Book</b> .....	<b>10-34</b>
<b>Storing/Editing One-Touch Buttons</b> .....	<b>10-35</b>
<b>Erasing One-Touch Buttons</b> .....	<b>10-39</b>

## Chapter 11 System Manager Settings

---

<b>System Settings Table</b> .....	<b>11-2</b>
<b>Communications Settings</b> .....	<b>11-4</b>
E-Mail/I-Fax Settings .....	11-4
Fax Settings .....	11-7
Memory RX Inbox Settings .....	11-9
Setting the Memory RX Inbox Password .....	11-9
Storing Received Fax Documents in Memory .....	11-10
Storing Received I-Fax Documents in Memory .....	11-11
Memory Lock Start Time Settings .....	11-11
Memory Lock End Time Settings .....	11-13
<b>Restricting Send Function</b> .....	<b>11-15</b>
Address Book Password .....	11-15
Access Number Management .....	11-16
Restricting New Addresses .....	11-16
Setting Whether to Allow Sending Using the Fax Driver .....	11-17
Setting to Confirm Entered Fax Numbers .....	11-18
Restricting the Domains to Which E-mail/I-Fax Documents Can Be Sent .....	11-19
Allowing the Sending of PDF Documents With Expired Certificates .....	11-20
Setting to Always Add a Device Signature to PDF Documents .....	11-21
<b>Forwarding Settings</b> .....	<b>11-22</b>
Storing Forwarding Settings .....	11-23



When Forwarding Destinations Do Not Match the Forwarding Conditions . . . . .	11-35
Checking/Changing Forwarding Settings . . . . .	11-40
Forwarding Received Documents . . . . .	11-41
Erasing Forwarding Settings . . . . .	11-41
Printing Forwarding Settings . . . . .	11-42
<b>LDAP Server Settings . . . . .</b>	<b>11-43</b>
Registering an LDAP Server . . . . .	11-43
Changing an LDAP Server Setting . . . . .	11-48
Deleting an LDAP Server . . . . .	11-48
Registering/Editing LDAP Search Attributes . . . . .	11-49
Printing LDAP Server Settings . . . . .	11-50

## **Chapter 12 Printing Communication Reports**

---

<b>Report Settings Table . . . . .</b>	<b>12-2</b>
<b>Specifying Report Settings . . . . .</b>	<b>12-4</b>
Send TX Report . . . . .	12-4
Activity Report . . . . .	12-5
Fax TX Report . . . . .	12-7
Fax Activity Report . . . . .	12-8
Fax RX Report . . . . .	12-9
Confidential Fax Inbox RX Report . . . . .	12-10
<b>Printing Lists . . . . .</b>	<b>12-11</b>
Address Book List . . . . .	12-11
User's Data List . . . . .	12-12
Printing the User's Data List for send . . . . .	12-12
Printing the User's Data List for fax . . . . .	12-12

## **Chapter 13 Troubleshooting**

---

<b>When Problems Occur . . . . .</b>	<b>13-2</b>
Sending Documents . . . . .	13-2
Receiving Documents . . . . .	13-5
Other Situations . . . . .	13-7
<b>Error Messages . . . . .</b>	<b>13-9</b>
Self-Diagnostic Display . . . . .	13-9
List of Error Codes without Messages . . . . .	13-14
<b>Questions &amp; Answers . . . . .</b>	<b>13-37</b>

## Chapter 14 Appendix

---

<b>Report and List Samples</b> . . . . .	<b>14-2</b>
Send Job List . . . . .	14-2
Send TX Report . . . . .	14-3
Fax TX Report/Fax Error TX Report. . . . .	14-5
Multiple Communication Result Report . . . . .	14-6
Fax RX Report . . . . .	14-8
Confidential Fax Inbox Reception Report. . . . .	14-9
Activity Report . . . . .	14-11
Fax Activity Report . . . . .	14-13
Forwarding Conditions List. . . . .	14-15
Registered LDAP Server List . . . . .	14-16
Address Book List . . . . .	14-17
User's Data List . . . . .	14-19
<b>Specifications</b> . . . . .	<b>14-21</b>
Universal Color Send . . . . .	14-21
Super G3 FAX Board . . . . .	14-23
Super G3 Multi-Line Fax Board . . . . .	14-24
<b>Glossary</b> . . . . .	<b>14-25</b>
<b>Index</b> . . . . .	<b>14-39</b>

# Preface





Thank you for purchasing the Canon Color imageRUNNER C3380/C3380i/C2880/C2880i. Please read this manual thoroughly before operating the machine to familiarize yourself with its capabilities, and to make the most of its many functions. After reading this manual, store it in a safe place for future reference.

## How To Use This Manual

---

### Symbols Used in This Manual

The following symbols are used in this manual to explain procedures, restrictions, handling precautions, and instructions that should be observed for safety.

-  **WARNING** Indicates a warning concerning operations that may lead to death or injury to persons if not performed correctly. To use the machine safely, always pay attention to these warnings.
-  **CAUTION** Indicates a caution concerning operations that may lead to injury to persons, or damage to property if not performed correctly. To use the machine safely, always pay attention to these cautions.
-  **IMPORTANT** Indicates operational requirements and restrictions. Be sure to read these items carefully to operate the machine correctly, and avoid damage to the machine.
-  **NOTE** Indicates a clarification of an operation, or contains additional explanations for a procedure. Reading these notes is highly recommended.

## Keys Used in This Manual

The following symbols and key names are a few examples of how keys to be pressed are expressed in this manual:

- Touch Panel Display Keys: [Key Name]

Examples:                      [Cancel]  
   [Done]

- Control Panel Keys:        Key Icon (Key Name)

Examples:                      Ⓞ (Start)  
   Ⓞ (Stop)

Hereafter, the following name substitutions take place:

- Transmission/Sending:    TX
- Reception/Receiving:    RX

## Displays Used in This Manual

Screen shots of the touch panel display used in this manual are those taken when the following optional equipment is attached to the Color imageRUNNER C3380i: the Super G3 FAX Board, Finisher-Z1, and Cassette Feeding Unit-Y3.

Note that functions that cannot be used depending on the model or options, are not displayed on the touch panel display.

The keys which you should press are marked with a , as shown below.

When multiple keys can be pressed on the touch panel display, all keys are marked. Select the keys which suit your needs.

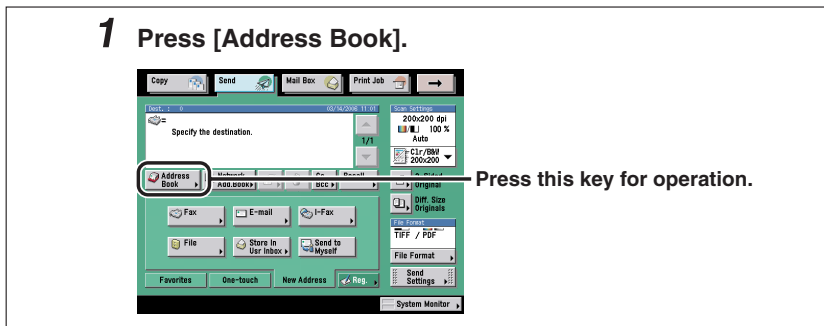

## Illustrations Used in This Manual

Illustrations used in this manual are those displayed when the Color imageRUNNER C3380i has the following optional equipment attached to it: the Finisher-Z1 and Cassette Feeding Unit-Y3.

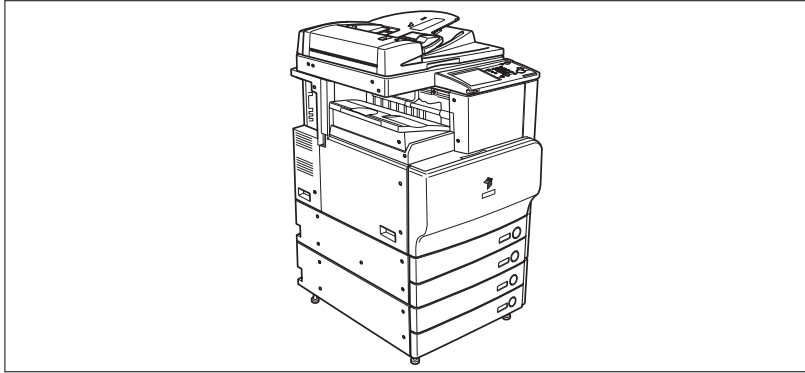

## Abbreviations Used in This Manual

In this manual, product names and model names are abbreviated as follows:

Microsoft® Windows® 98 operating system:	Windows 98
Microsoft® Windows® Millennium Edition operating system:	Windows Me
Microsoft® Windows® 2000 operating system:	Windows 2000
Microsoft® Windows® XP operating system:	Windows XP
Microsoft® Windows Server™ 2003 operating system:	Windows Server 2003
Microsoft® Windows® operating system:	Windows
Novell NetWare®:	NetWare

# Legal Notices

---

## FCC (Federal Communications Commission)

This equipment has been tested and found to comply with the limits for a Class A digital device, pursuant to Part 15 of the FCC Rules. These limits are designed to provide reasonable protection against harmful interference when the equipment is operated in a commercial environment. This equipment generates, uses, and can radiate, radio frequency energy and, if not installed and used in accordance with the Operator's Manual, may cause harmful interference to radio communications. Operation of this equipment in a residential area is likely to cause harmful interference in which case the user will be required to correct the interference at his own expense.

Use of shielded cable is required to comply with Class A limits in Subpart B of Part 15 of the FCC Rules.

Do not make any changes or modifications to the equipment unless otherwise specified in the manual. If you make such changes or modifications, you could be required to stop operation of the equipment.

## Users in the U.S.A.

### Preinstallation Requirements for Canon Facsimile Equipment

#### A. Location

Supply a suitable table, cabinet, or desk for the machine. See Chapter 9, "Appendix," in the *Reference Guide* for specific dimensions and weight.

#### B. Order Information

1. A single telephone line (touch-tone or rotary) should be used. If the optional Super G3 Multi-Line Fax Board is installed, a dual telephone line (touch-tone or rotary) can be used.
2. Order an RJ11-C telephone wall jack (USOC), which should be installed by the telephone company. If the RJ11-C wall jack is not present, telephone/facsimile operation is not possible.

3. Order a normal business line from your telephone company's business representative. The line should be a regular voice grade line or an equivalent one. Use one line per unit. If the optional Super G3 Multi-Line Fax Board is installed, you can use a dual line.

DDD (Direct Distance Dial) line

-or-

IDDD (International Direct Distance Dial) line if you communicate overseas

#### NOTE

Canon recommends an individual line following industry standards, i.e., 2500 (touch-tone) or 500 (rotary/pulse dial) telephones. A dedicated extension off a PBX (Private Branch eXchange) unit without "Call Waiting" can be used with your facsimile unit. Key telephone systems are not recommended because they send nonstandard signals to individual telephones for ringing and special codes, which may cause a facsimile error.

### **C. Power Requirements**

The machine should be connected to a standard 120 volt AC, three-wire grounded outlet only.

Do not connect this machine to an outlet or power line shared with other appliances that cause "electrical noise." Air conditioners, electric typewriters, copiers, and machines of this sort generate electrical noise that often interferes with communications equipment and the sending and receiving of documents.

### **Connection of the Equipment**

This equipment complies with Part 68 of the FCC rules and the requirements adopted by the ACTA. On the rear panel of this equipment is a label that contains, among other information, a product identifier in the format of US:AAAEQ##TXXXX. If requested, this number must be provided to the telephone company.

The REN (Ringer Equivalence Number) is used to determine the number of devices that may be connected to a telephone line. Excessive RENs on a telephone line may result in the devices not ringing in response to an incoming call. In most, but not all areas, the sum of the RENs should not exceed five (5.0). To be certain of the number of devices that may be connected to a line, as determined by the total RENs, contact the local telephone company. The REN for this product is part of the product identifier that has the format US:AAAEQ##TXXXX. The digits represented by ## are the REN without a decimal point (e.g., 10 is a REN of 1.0).

An FCC compliant telephone line cable and modular plug is provided with this equipment. This equipment is designed to be connected to the telephone network or premise wiring using a compatible modular jack that is Part 68 compliant.

This equipment may not be used on coin service provided by the telephone company. Connection to party lines is subject to state tariffs.

## In Case of Equipment Malfunction

Should any malfunction occur which cannot be corrected by the procedures described in this guide or the *Reference Guide*, disconnect the equipment from the telephone line cable and disconnect the power cord. The telephone line cable should not be reconnected or the main power switch turned ON until the problem is completely resolved. Users should contact their local authorized Canon Facsimile Service Dealer for the servicing of equipment.

If your equipment malfunctions, please contact your local authorized Canon dealer from whom you purchased the equipment (if under warranty), or with whom you have a servicing contract. If you are not sure who to contact, and have both purchased and are using the equipment in the U.S.A., please refer to the "SUPPORT" page on Canon U.S.A.'s Web site (<http://www.usa.canon.com>).

## Rights of the Telephone Company

If this equipment (Color imageRUNNER C3380/C3380i/C2880/C2880i) causes harm to the telephone network, the telephone company may temporarily disconnect service. The telephone company also retains the right to make changes in facilities and services that may affect the operation of this equipment. When such changes are necessary, the telephone company is required to give adequate prior notice to the user. However, if advance notice is not possible, the telephone company will notify the customer as soon as possible. Also, the customer will be advised of his/her right to file a complaint with the FCC if he/she believes it is necessary.



### WARNING

**The Telephone Consumer Protection Act of 1991 makes it unlawful for any person to use a computer or other electronic device to send any message via a telephone facsimile machine unless such message clearly contains in a margin at the top or bottom of each transmitted page, or on the first page of the transmission, the date and time it is sent and an identification of the business or other entity, or other individual sending the message and the telephone number of the sending machine or such business, other entity, or individual.**



### NOTE

To program this information into your machine, complete the procedure for registering your name, unit's telephone number, time, and date in Chapter 1. (For instructions on entering characters, see Chapter 2, "Basic Operations," in the *Reference Guide*.)



## Preinstallation Requirements for Canon Facsimile Equipment

### A. Location

Supply a suitable table, cabinet, or desk for the machine. See Chapter 9, "Appendix," in the *Reference Guide* for specific dimensions and weight.

### B. Order Information

1. A single telephone line (touch-tone or rotary) should be used. If the optional Super G3 Multi-Line Fax Board is installed, a dual telephone line (touch-tone or rotary) can be used.
2. Order a CA11A modular jack which should be installed by the telephone company. If the CA11A jack is not present, installation cannot occur.
3. Order a normal business line from your telephone company's business representative. The line should be a regular voice grade line or an equivalent one. Use one line per unit. If the optional Super G3 Multi-Line Fax Board is installed, you can use a dual line.

DDD (Direct Distance Dial) line

or

IDDD (International Direct Distance Dial) line if you communicate overseas

#### NOTE

Canon recommends an individual line following industry standards, i.e., 2500 (touch-tone) or 500 (rotary/pulse dial) telephones. A dedicated extension off a PBX (Private Branch eXchange) unit without "Call Waiting" can be used with your facsimile unit. Key telephone systems are not recommended because they send nonstandard signals to individual telephones for ringing and special codes, which may cause a facsimile error.

### C. Power Requirements

The power outlet should be a three-prong grounded receptacle (Single or Duplex). It should be independent from copiers, heaters, air conditioners, or any electric equipment that is thermostatically controlled. The rated value is 115 volts and 15 amperes. The CA11A modular jack should be relatively close to the power outlet to facilitate installation.

### Notice

- This product meets the applicable Industry Canada technical specifications.

- Before installing this equipment, users should ensure that it is permissible to be connected to the facilities of the local telecommunications company. The equipment must also be installed using an acceptable method of connection. In some cases, the company's inside wiring associated with a single line individual service may be extended by means of a certified connector assembly (telephone extension cord). The customer should be aware that compliance with the above conditions may not prevent deterioration of service in some situations.
- The Ringer Equivalence Number is an indication of the maximum number of devices allowed to be connected to a telephone interface. The termination of an interface may consist of any combination of devices subject only to the requirement that the sum of the RENs of all the devices does not exceed five.
- The REN of this product is 1.0.
- Repairs to certified equipment should be made by an authorized Canadian maintenance facility designated by the supplier. Any repairs or alterations made by the user to this equipment, or equipment malfunctions, may give the telecommunications company cause to request the user to disconnect the equipment.
- Users should ensure for their own protection that the electrical ground connections of the power utility, telephone lines, and internal metallic water pipe system, if present, are connected together. This precaution may be particularly important in rural areas.

 **CAUTION**

**Users should not attempt to make such connections themselves, but should contact the appropriate electric inspection authority, or electrician, as appropriate.**

 **NOTE**

This equipment complies with the Canadian ICES-003 Class A limits.

## Utilisation au Canada

### Conditions à Remplir Préalablement à L'installation d'un Télécopieur Canon

#### A. Emplacement

Prévoir une table, un meuble, ou un bureau suffisamment solide et de taille appropriée (voir le chapitre 9, Annexe (Appendix), du *Guide de référence (Reference Guide)* pour les indications de poids et dimensions).

## B. Installation téléphonique

1. Une seule ligne téléphonique (tonalités ou impulsions) doit être utilisée. Si la Carte FAX (Super G3) Multi Ligne en option est installée, il est possible d'utiliser une ligne téléphonique double (tonalités ou impulsions).
2. Il faut commander un jack modulaire CA11A qui sera installé par la compagnie téléphonique. Sans ce jack, la mise en place serait impossible.
3. Si vous vous abonnez à une nouvelle ligne, demandez une ligne d'affaires normale de qualité téléphonique courante ou équivalente. Prenez un abonnement d'une ligne par appareil. Si la Carte FAX (Super G3) Multi Ligne en option est installée, il est possible d'utiliser une ligne téléphonique double.

Ligne automatique interurbaine

ou

Ligne automatique internationale  
(si vous communiquez avec les pays étrangers)

### NOTE

Canon vous conseille d'utiliser une ligne individuelle conforme aux normes industrielles, à savoir: ligne téléphonique 2500 (pour appareil à clavier) ou 500 (pour appareil à cadran/impulsions). Il est également possible de raccorder ce télécopieur à un système téléphonique à poussoirs car la plupart de ces systèmes émettent des signaux d'appel non normalisés ou des codes spéciaux qui risquent de perturber le fonctionnement du télécopieur.

## C. Condition d'alimentation

Raccordez le télécopieur à une prise de courant plus terre à trois branches, du type simple ou double, et qui ne sert pas à alimenter un copieur, un appareil de chauffage, un climatiseur ou tout autre appareil électrique à thermostat.

L'alimentation doit être de 115 volts et 15 ampères. Pour faciliter l'installation, le jack CA11A doit être assez proche de la prise de courant.

## Remarques

- Le présent matériel est conforme aux spécifications techniques applicables d'Industrie Canada.
- Avant d'installer cet appareil, l'utilisateur doit s'assurer qu'il est permis de le connecter à l'équipement de la compagnie de télécommunication locale et doit installer cet appareil en utilisant une méthode de connexion autorisée. Il se peut qu'il faille étendre la circuiterie intérieure de la ligne individuelle d'abonné, qui a été installée par la compagnie, au moyen d'un jeu de connecteurs homologués (rallonge téléphonique).  
L'attention de l'utilisateur est attirée sur le fait que le respect des conditions mentionnées ci-dessus ne constitue pas une garantie contre les dégradations de qualité du service dans certaines circonstances.

- L'indice d'équivalence de la sonnerie (IES) sert à indiquer le nombre maximal de terminaux qui peuvent être raccordés à une interface téléphonique. La terminaison d'une interface peut consister en une combinaison quelconque de dispositifs, à la seule condition que la somme d'indices d' équivalence de la sonnerie de tous les dispositifs n'excède pas 5.
- Le nombre d'équivalents sonnerie (REN) de ce produit est 1.0.
- Les réparations sur un appareil certifié doivent être faites par une société d'entretien canadienne autorisée par le Gouvernement canadien et désignée par le fournisseur. Toute réparation ou modification que pourrait faire l'utilisateur de cet appareil, ou tout mauvais fonctionnement, donne à la compagnie de télécommunication le droit de débrancher l'appareil.
- Pour sa propre protection, l'utilisateur doit s'assurer que les prises de terre de l'appareil d'alimentation, les lignes téléphoniques et les tuyaux métalliques internes, s'il y en a, sont bien connectés entre eux. Cette précaution est particulièrement importante dans les zones rurales.

### CAUTION

**Au lieu d'essayer de faire ces branchements eux-mêmes, les utilisateurs sont invités à faire appel à un service d'inspection faisant autorité en matière d'électricité ou à un électricien, selon le cas.**

### NOTE

Respecte les limites de la classe A de la NMB-003 du Canada.

## Super G3



Super G3 is a phrase used to describe the new generation of fax machines that use ITU-T V.34 standard 33.6 Kbps\* modems. Super G3 High Speed Fax machines allow transmission times of approximately 3 seconds\* per page which results in reduced telephone line charges.

\* Approximately 3 seconds per page fax transmission time based on CCITT/ITU-T No.1 Chart, (JBIG, Standard Mode) at 33.6 Kbps modem speed. The PSTN (Public Switched Telephone Network) currently supports 28.8 Kbps modem speeds or slower, depending on telephone line conditions.

## Trademarks

Canon, the Canon logo, Color imageRUNNER, MEAP, and NetSpot are registered trademarks, and the MEAP logo, imageWARE, and imageWARE Accounting Manager are trademarks of Canon Inc. in the United States and may also be trademarks or registered trademarks in other countries.

Adobe, Adobe Acrobat, and Adobe Illustrator are trademarks of Adobe Systems Incorporated.

Mac OS is a trademark of Apple Computer, Inc.

IBM and OS/2 are trademarks of International Business Machines Corporation.

Linux is a registered trademark of Linus Torvalds.

Active Directory, Microsoft, MS-DOS, and Windows are registered trademarks of Microsoft Corporation in the United States and other countries.

Windows Server is a trademark of Microsoft Corporation in the United States and other countries.

NetWare® and Novell are registered trademarks of Novell, Inc.

NDS is a trademark of Novell, Inc.

UNIX is a registered trademark of The Open Group in the United States and other countries.

Red Hat is a trademark of Red Hat, Inc. in the United States and other countries.

Solaris and Sun are trademarks of Sun Microsystems in the United States and other countries.

Ethernet is a trademark of Xerox Corporation.

Other product and company names herein may be the trademarks of their respective owners.

## Copyright

Copyright 2006 by Canon Inc. All rights reserved.

No part of this publication may be reproduced or transmitted in any form or by any means, electronic or mechanical, including photocopying and recording, or by any information storage or retrieval system without the prior written permission of Canon Inc.

## Disclaimers

The information in this document is subject to change without notice.

CANON INC. MAKES NO WARRANTY OF ANY KIND WITH REGARD TO THIS MATERIAL, EITHER EXPRESS OR IMPLIED, EXCEPT AS PROVIDED HEREIN, INCLUDING WITHOUT LIMITATION, THEREOF, WARRANTIES AS TO MARKETABILITY, MERCHANTABILITY, FITNESS FOR A PARTICULAR PURPOSE OF USE OR NON-INFRINGEMENT. CANON INC. SHALL NOT BE LIABLE FOR ANY DIRECT, INCIDENTAL, OR CONSEQUENTIAL DAMAGES OF ANY NATURE, OR LOSSES OR EXPENSES RESULTING FROM THE USE OF THIS MATERIAL.

# Important Safety Instructions

---

Please read these "Important Safety Instructions" thoroughly before operating the machine. As these instructions are intended to prevent injury to the user or other persons or destruction of property, always pay attention to these instructions. Also, since it may result in unexpected accidents or injuries, do not perform any operation unless otherwise specified in the manual. Improper operation or use of this machine could result in personal injury and/or damage requiring extensive repair that may not be covered under your Limited Warranty.

## Telephone Equipment

### **WARNING**

When using telephone equipment, basic safety precautions should always be followed to reduce the risk of fire, electric shock, and injury to persons, including the following:

1. Do not use this machine near water (i.e., near a bathtub, kitchen sink, or laundry tub), or in a wet basement or near a swimming pool.
2. Avoid using the telephone during an electrical storm, as there may be a remote risk of electric shock from lightning.
3. Do not use the telephone to report a gas leak in the vicinity of the leak.





# Introduction to Sending and Fax Functions

# 1

## CHAPTER

This chapter is an introduction to the Send function.

---

What This Machine Can Do . . . . .	1-2
Overview of the Color imageRUNNER C3380/C3380i/C2880/C2880i . . . . .	1-6
Things You Must Do Before Using This Machine . . . . .	1-11
Setting the Display Language . . . . .	1-13
Selecting the Type of Telephone Line . . . . .	1-14
Setting the Current Date and Time . . . . .	1-14
Registering Your Machine's Fax Number . . . . .	1-16
Registering Sender Names . . . . .	1-17
Registering the Unit's Name . . . . .	1-18
Flow of Sending Operations . . . . .	1-20
Sending Fax Documents Manually . . . . .	1-31
Canceling a Job . . . . .	1-35
Using the Touch Panel Display . . . . .	1-35
Using the Stop Key . . . . .	1-36
Using the System Monitor Screen . . . . .	1-36

# What This Machine Can Do

## All the elements you will ever need in a color digital multitasking machine.

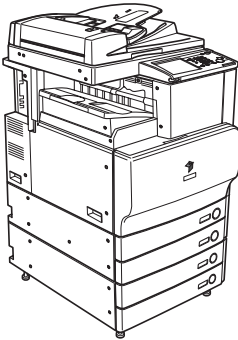

The Color imageRUNNER C3380/C3380i/C2880/C2880i is packed with various send functions.

Equipped with features that meet the needs of document work in a digitized office, the Color imageRUNNER C3380/C3380i/C2880/C2880i represents the ultimate in digital multitasking machines.

### Diverse Sending Methods

You can easily scan paper documents and send them to one or multiple recipients via fax, e-mail, or I-fax, bringing to your work environment increased efficiency in the arena of document exchange. The ability to send documents to FTP, SMB, NetWare, and WebDAV file servers also serves to help digitize paper documents for convenient data access and management.

Sending documents via fax is available only if the optional Super G3 FAX Board or Super G3 Multi-Line Fax Board is installed.

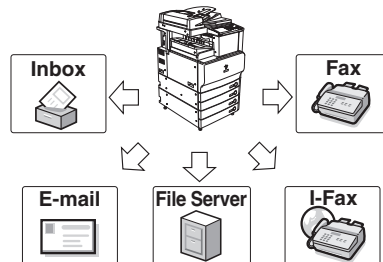

---

## Super G3 Fax Function

---

This machine's Super G3 fax function is compatible with most Super G3 fax machines used in office environments. Compared to ordinary fax machines, Super G3 enables high-speed fax transmissions, thus reducing transmission costs. You can add an additional line if the optional Super G3 Multi-Line Fax Board is installed.

This function is available only if the optional Super G3 FAX Board or Super G3 Multi-Line Fax Board is installed.

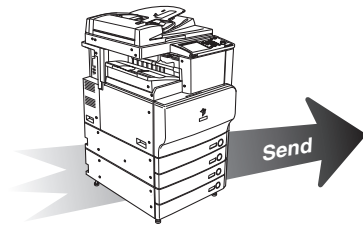

---

## Increased Security with Subaddress Transmission

---

This machine's fax function is compatible with ITU-T (International Telecommunication Union - Telecommunication Standardization Sector) standard subaddress features. As long as the remote party's fax machine supports subaddress fax transmissions, you can send or receive documents with increased security by attaching a subaddress and a password to all of your fax transactions.

This function is available only if the optional Super G3 FAX Board or Super G3 Multi-Line Fax Board is installed.

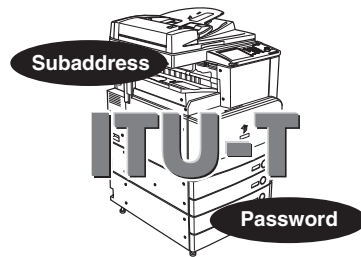

---

## ECM Function for High Quality Images

---

This machine's fax function is compatible with ECM (Error Correction Mode). ECM corrects errors and distorted or poor quality fax transmissions that arise from line noise. It also enables you to send or receive high-quality faxes even if the condition of your telephone line is not ideal.

This function is available only if the optional Super G3 FAX Board or Super G3 Multi-Line Fax Board is installed.

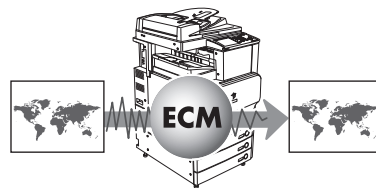

## File Formats for Every Need

You can send documents in a variety of file formats, including TIFF, JPEG, and PDF. This gives you the freedom to send documents in a manner that is best suited to the purpose of the document, as well as the recipient's document handling environment.

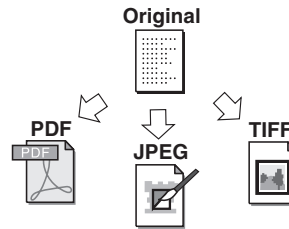

## Flexible Scan Features

This machine offers a variety of convenient scanning features, such as the scanning of two-sided and book originals, as well as the ability to merge and send documents that are scanned separately. You can also set the exposure, color mode, and document size to match the type of original that you are scanning. In addition, you can store preferred scan settings and retrieve them at any time.

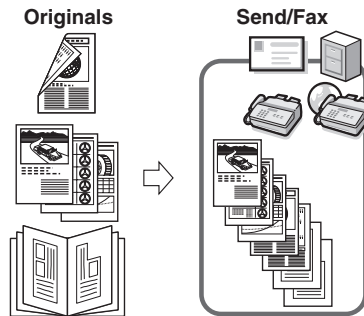

## Preview Function

The Preview function enables you to check the contents of documents before sending them. This is useful in preventing mistakes.

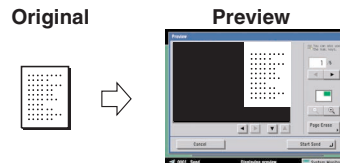

## Instant Address Search with LDAP

You can search for addresses stored on LDAP (Lightweight Directory Access Protocol) servers on the network and use them as recipients for send jobs or store them in the Address Book.

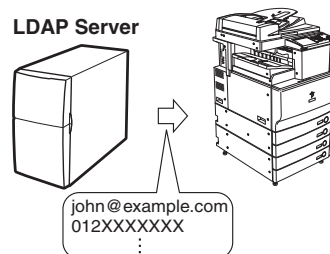

## Receiving Faxes/I-Faxes in Memory

Received fax/I-fax documents can be stored in the Memory RX Inbox instead of being printed. You can check the sender information and the number of pages that each document contains before printing it or forwarding it to another destination.

Receiving faxes in memory is available only if the optional Super G3 FAX Board or Super G3 Multi-Line Fax Board is installed.

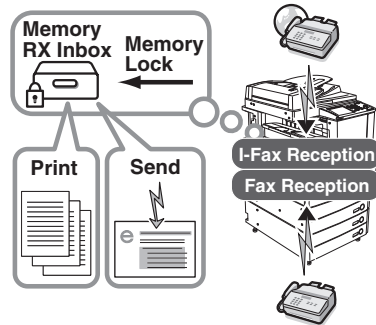

## Automatic Forwarding

The machine can be set to automatically forward received fax/I-fax documents that match the specified forwarding conditions to any destination using the desired send settings. You can forward fax/I-fax documents to other machines (relay function) or store received documents that are confidential in Confidential Fax Inboxes. Automatic forwarding can be set to activate at a specified time. Since received documents that do not match the forwarding conditions can also be forwarded to any desired destination, this function can be used to sort and deliver received fax/I-fax documents to the appropriate destinations.

If the optional Super G3 FAX Board or Super G3 Multi-Line Fax Board is installed, the machine can receive faxes and forward received fax documents to fax machines.

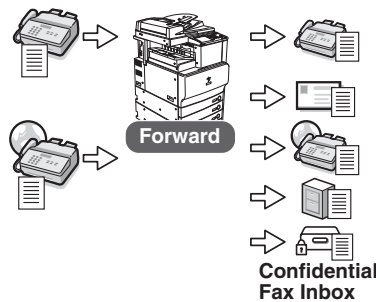

# Overview of the Color imageRUNNER C3380/C3380i/ C2880/C2880i

If you press [Send], the Send Basic Features screen appears. The Send function enables you to scan documents and send them to specified destinations via fax, e-mail, or I-fax, save them to a file server, or store them in an inbox to process them at a later date. You can also send documents to multiple destinations simultaneously using various sending methods, such as e-mail and I-fax.

Depending on the installed option, the Send Basic Features screen is displayed as follows:

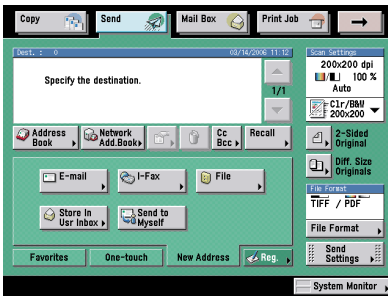

If the optional Super G3 FAX Board or Super G3 Multi-Line Fax Board is not installed

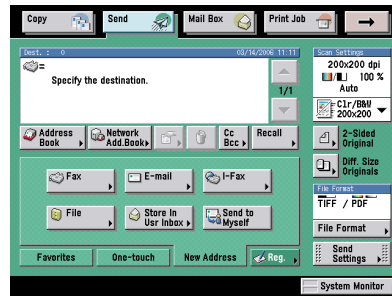

If the optional Super G3 FAX Board or Super G3 Multi-Line Fax Board is installed

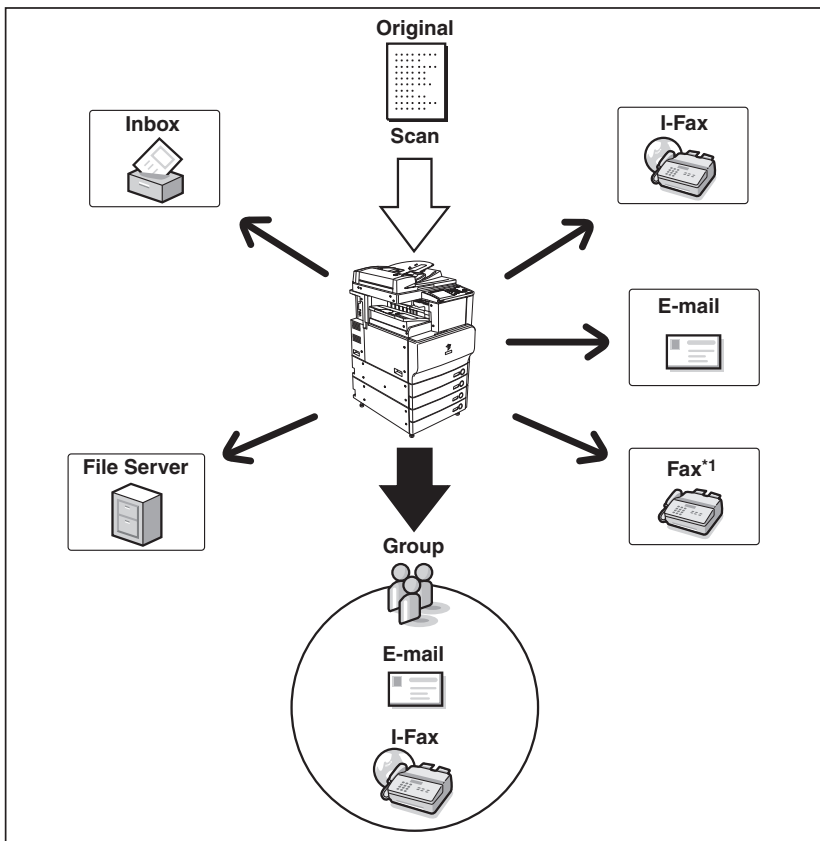

\*1 Available only if the optional Super G3 FAX Board or Super G3 Multi-Line Fax Board is installed.

The Flow of the sending is as follows.

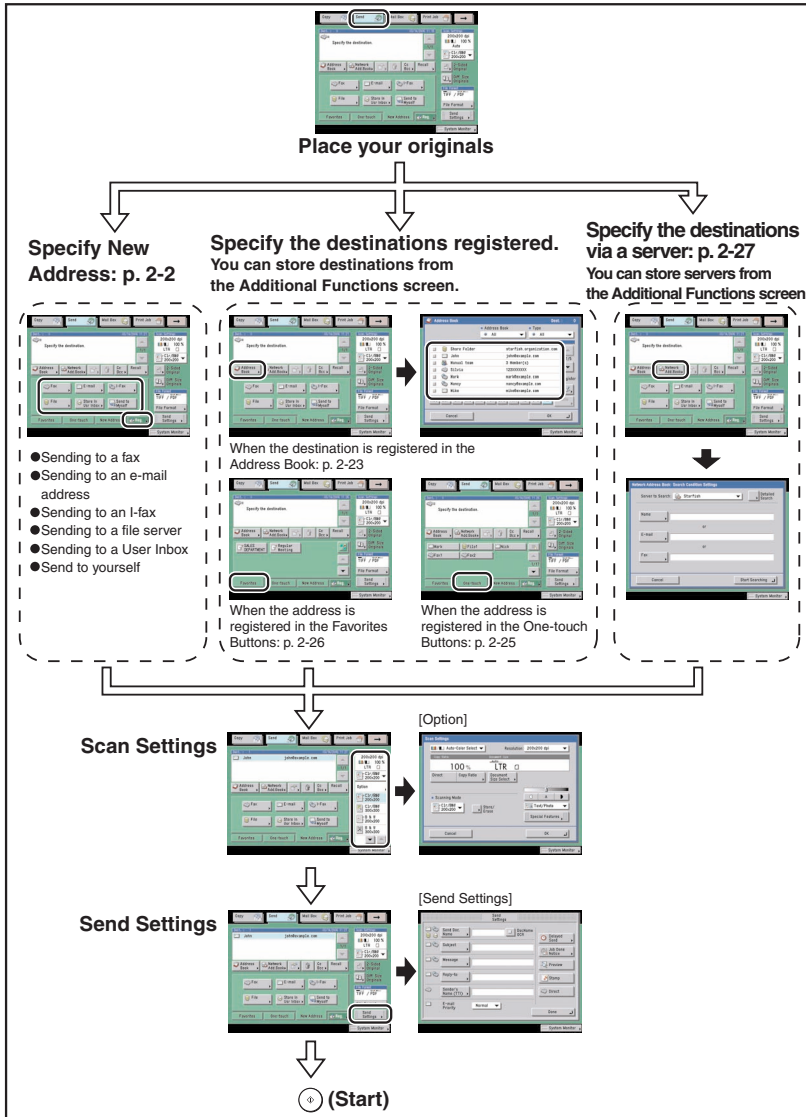

**IMPORTANT**

Network settings must be specified to be able to send scanned documents to an e-mail address, an I-fax address, or a file server. (See the *Network Guide*.)



## ■ Send Basic Features Screen

The screen below, which appears when [Send] is selected, is called the Send Basic Features screen.

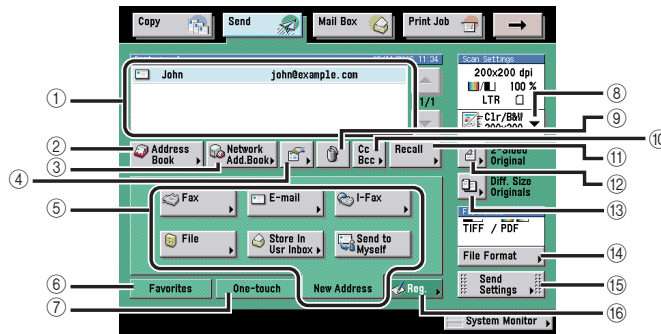

- |   |  |
|---|--|
| <p>① Destination List<br/>Displays a list of destinations.</p>  | <p>⑨ Erase<br/>Press to erase the destination displayed in the destination list.</p>   |
| <p>② Address Book<br/>Press to select a destination from the Address Book.</p>                                | <p>⑩ Cc Bcc<br/>Press to specify the e-mail address as a Cc or Bcc destination.</p>  |
| <p>③ Network Address Book<br/>Press to search a destination from the LDAP server.</p>                         | <p>⑪ Recall<br/>Press to recall previously set send jobs, including the destinations, scan settings, and send settings.</p>  |
| <p>④ Details<br/>Press to check or change the destination information selected from the destination list.</p> | <p>⑫ 2-Sided Original<br/>Press to scan both sides of the original.</p>  |
| <p>⑤ New Address Tab<br/>Press to specify a destination not stored in the Address Book.</p>                   | <p>⑬ Different Size Originals<br/>Press to scan different sized originals together.</p>  |
| <p>⑥ Favorites Tab<br/>Press to recall the destinations and settings stored in a favorites button.</p>        | <p>⑭ File Format<br/>Press to select the file format of the document you are going to send (PDF, JPEG, or TIFF).</p>   |
| <p>⑦ One-touch Tab<br/>Press to recall the destinations stored in a one-touch button.</p>                     | <p>⑮ Send Settings<br/>Press to set the send settings. You can specify various settings, such as setting the document to be sent at a specified time, entering a subject for an e-mail or an I-fax, or entering the sender's name for fax.</p> |
| <p>⑧ Scan Settings drop-down list<br/>Press to select the scan mode.</p>                                      | <p>⑯ Register<br/>Press to register new destinations in the Address Book, one-touch buttons, or favorites buttons from the Send Basic Features screen.</p>   |

## ■ Scan Settings Screen

The screen below, which appears when you press [Option] from the Scan Settings drop-down list, is called the Scan Settings screen. Display this screen to set the scan settings for sending documents.

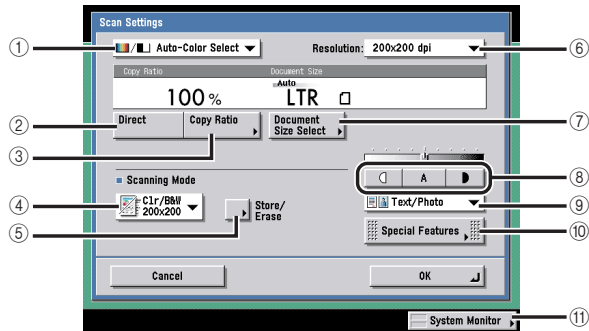

- |  |  |
|--|--|
| <p>① Color Mode drop-down list<br/>Press to select the color mode for scanning.</p>          | <p>⑦ Document Size Select<br/>Press to select the size of the original that you want to scan.</p>  |
| <p>② Direct<br/>Press to return the scan ratio to 100%.</p>                                  | <p>⑧ Scan Exposure<br/>Press [◀] or [▶] to manually adjust the scan exposure. Press [A] (Auto) to select or cancel the automatic scan exposure adjustment.</p> |
| <p>③ Copy Ratio<br/>Press to scan originals at a different scan (zoom) ratio.</p>            | <p>⑨ Original Type drop-down list<br/>Press to select the type of original (Text/Photo, Photo, or Text) that you are going to scan.</p>                        |
| <p>④ Scanning Mode drop-down list<br/>Press to select a stored scan mode and resolution.</p> | <p>⑩ Special Features<br/>Press to select and use the Special Features modes available for scanning.</p>   |
| <p>⑤ Store/Erase<br/>Press to store or erase a scan mode.</p>                                | <p>⑪ System Monitor<br/>Press to check the status or details of a send or receive job, or to cancel a job.</p>   |
| <p>⑥ Resolution drop-down list<br/>Press to select the resolution.</p>                       |  |

# Things You Must Do Before Using This Machine

This section describes the important setting registrations and procedures that must be done before the machine is used for sending operations.

According to recent amendments to the FCC (Federal Communications Commission) rules governing the use of facsimile equipment in the United States, the following sender information must be printed on every facsimile transmission:

- Your fax number
- Your personal name or company name
- Time and date of transmission

## IMPORTANT

- If you attempt to use the machine without registering the necessary information correctly, the machine may not function properly.
- Network settings must be specified to send scanned documents to an e-mail address, an I-fax address, or a file server. (See the *Network Guide*.)

## NOTE

To send documents to a fax destination, the optional Super G3 FAX Board or Super G3 Multi-Line Fax Board is required.

## ■ Setting the Telephone Line Type

To set the type of telephone line connected to the machine with the optional Super G3 FAX Board or Super G3 Multi-Line Fax Board installed, check whether it is a rotary dial (rotary pulse) or a touch-tone type and make the correct setting. (See "Selecting the Type of Telephone Line," on p. 1-14.)

If you have added an additional line to the machine, perform the same registration procedure for the additional line, too. (See "Selecting the Telephone Line Type for an Additional Line," on p. 9-51.)

## ■ Registering the Sending Record

The sending record is printed at the top of every document you send via I-fax or fax to the recipient.

The registered information is printed, as shown below. Depending upon the model of the machine at the receiving side, this information may appear on the display while communication is taking place.

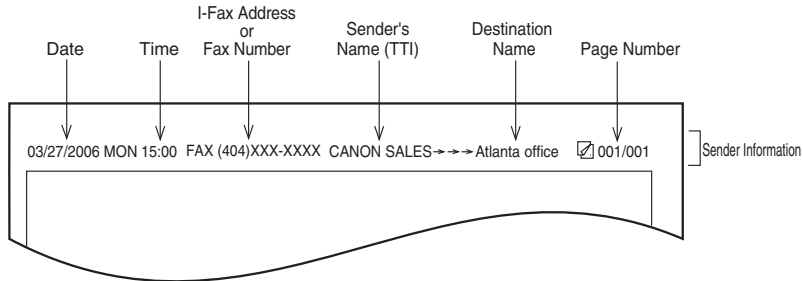

- **Date and Time**
  - The date and time of the transmission are recorded.
- **I-Fax Address or Fax Number**
  - Your machine's I-fax address or fax number is recorded.
- **Sender's Name (TTI (Transmit Terminal Identification))**
  - For fax documents, the name registered as the sender's name is recorded.
- **Destination Name**
  - If you send an original and select a destination from the Address Book, the stored destination's name appears on the sending record. (See "Storing New Addresses," on p. 10-5.)
- **Page Number**
  - The current page number out of the total number of pages of the original is recorded.

### NOTE

- You can set the machine so that the sending record is not printed. However, for users in the United States, this information must be printed at the top of every fax or I-fax document that you send. Therefore, TX Terminal ID in TX Settings under <Common Settings> in Communications Settings (from the Additional Functions screen) must always be set to 'On'. (See "Printing the TX Terminal ID," on p. 9-28.)
- If the machine is set so that the sending record is printed at the top of the recording paper, and not all of the items are registered, only the required registered items and the total number of original pages are printed.
- To print the destination's name on the recipient's paper, set Display Destination Name in TX Terminal ID in TX Settings under <Common Settings> in Communications Settings (from the Additional Functions screen) to 'On'. (See "Printing the TX Terminal ID," on p. 9-28.)

### ■ Super G3 Multi-Line Fax Board

The optional Super G3 Multi-Line Fax Board enables you to add an additional line. A dual line can reduce the time it takes to send and receive documents. It is necessary to register a separate telephone number for the additional line. (See "Registering the Fax Number for an Additional Line," on p. 9-49.)

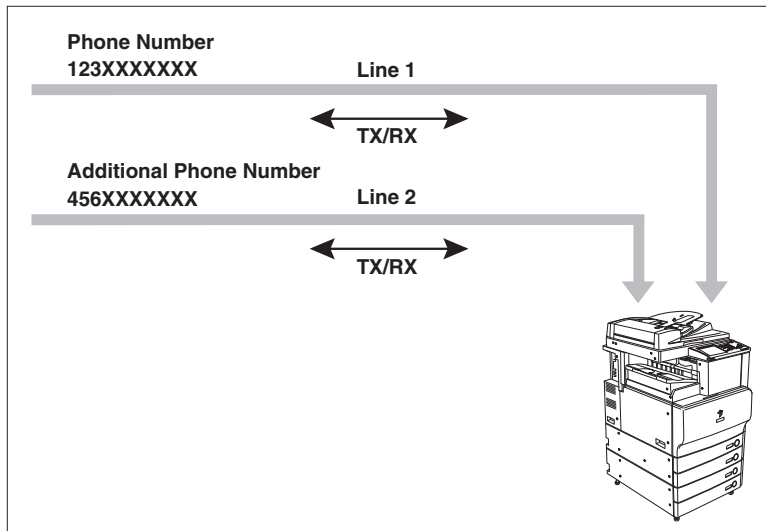

Line 1 (the standard line): Register the main fax line of the machine.

Line 2 (the additional line): Register an additional line to use when Line 1 is busy.

## Setting the Display Language

If you decide to switch the display language, set Language Switch to 'On' before entering characters.

If Language Switch is set to 'Off', and then you set it to 'On' after entering characters, the characters may not be displayed correctly. In this case, either re-enter the characters after setting Language Switch to 'On', or enter characters with Language Switch set to 'Off'.

## Selecting the Type of Telephone Line

Set the type of telephone line that is connected to the machine.

If this setting is incorrect, you will be unable to communicate with other machines. Be sure to check the type of telephone line that you are using, and make the correct setting.

### IMPORTANT

The telephone line type you can select here is for line 1. To select the telephone line type for an additional line, see "Selecting the Telephone Line Type for an Additional Line," on p. 9-51.

### NOTE

For this setting, the optional Super G3 FAX Board or Super G3 Multi-Line Fax Board is required.

---

**1** Press  (Additional Functions) → [Communications Settings] → [User Settings] under <Fax Settings> → [Tel Line Type].

**2** Select the type of telephone line → press [OK].

If you do not know the telephone line type, call your telephone service provider for details.



## Setting the Current Date and Time

You can set the current date and time. The current date and time settings are used as standard timer settings for functions that require them.

- GMT: GMT stands for Greenwich Mean Time.
- Time Zone: The standard time zones of the world are expressed globally in terms of the difference in hours ( $\pm$  up to 12 hours) from GMT ( $\pm$  0 hours). A time zone is a region throughout which this time difference is the same.
- Daylight Saving Time: In some countries, time is advanced throughout the summer season. The period in which this is applied is called "Daylight Saving Time."

 **NOTE**

You can also specify to automatically synchronize the date and time with a server on the network from the Additional Functions screen. (See Chapter 3, "Using a TCP/IP Network," in the *Network Guide*.)

- 1 Press  (Additional Functions) → [System Settings] → [Date & Time Settings].**
- 2 Enter the current date (month, day, year) and time using  -  (numeric keys).**

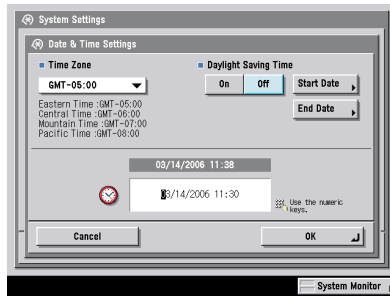

Enter the month and the day using four digits (including zeros).

Enter all four digits of the year, and the time in 24-hour notation, as four digits (including zeros) without a space.

- Examples: May 6 → 0506  
7:05 a.m. → 0705  
11:18 p.m. → 2318

● **If you are setting the Time Zone:**

- Press the Time Zone drop-down list → select the time zone where the machine is located.

● **If you are setting Daylight Saving Time:**

- Press [On] → [Start Date].
- Select the month and day from the Month and Day drop-down lists, respectively.
- Press [-] or [+] to enter the time of day you want Daylight Saving Time to take effect → press [OK].

- Press [End Date] → select the month, day, and time at which Daylight Saving Time ends → press [OK].



#### NOTE

If you set Daylight Saving Time, the machine automatically sets the standard time of the machine one hour forward at the specified date and time.

### 3 Press [OK].

## Registering Your Machine's Fax Number

You must store your machine's fax number. This number is printed on the document that you fax to the receiving party.

The number may also be displayed on the touch panel display of the receiving party's machine, depending on their type of machine.



#### IMPORTANT

The phone number you can register here is for line 1. To register the phone number for an additional line, see "Selecting the Telephone Line Type for an Additional Line," on p. 9-51.



#### NOTE

For this setting, the optional Super G3 FAX Board or Super G3 Multi-Line Fax Board is required.

- 1 Press **[☰]** (Additional Functions) → **[Communications Settings]** → **[User Settings]** under **<Fax Settings>** → **[Unit Telephone #]**.
- 2 Enter the unit's telephone number using **[0] - [9]** (numeric keys) → press **[OK]**.

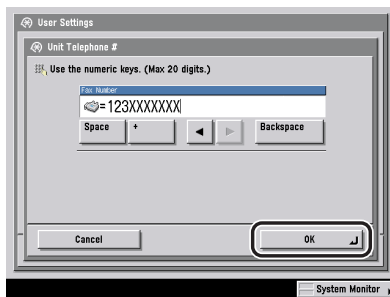



Details of each item are shown below.

[Space]: Press to insert a space between the area code and the local fax number.

[+]: Use to insert a country code. Press [+] after the country code, and before the fax number.

[◀][▶]: Press to move the position of the cursor.

[Backspace]: Press to delete the last number entered.

## Registering Sender Names

For fax, you can register any name as the sender's name, such as the section or department's name, or an individual's name.

The registered sender's name can be displayed on the touch panel display of the receiving party's machine and/or printed at the top of the documents that you send as the sender's information.

### NOTE

- You can set to display and print the sender's name instead of the name stored as the unit's name with the Sender's Names setting from the Send Settings screen. (See "Sending a Fax," on p. 5-2.)
- For this setting, the optional Super G3 FAX Board or Super G3 Multi-Line Fax Board is required.

---

**1** Press  (Additional Functions) → [Communications Settings] → [TX Settings] under <Common Settings> → [Sender's Names (TTI)].

## 2 Select the number under which you want to register the sender's name → press [Register/Edit].

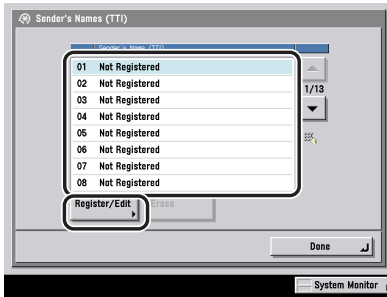

You can store up to 99 sender names (01 to 99).

To delete a stored sender's name, select the number under which the name is registered → press [Erase]. Only one sender name can be erased at a time.

## 3 Enter the sender's name → press [OK].

### Registering the Unit's Name

Your name or company's name must be registered as the unit's name (a department name is optional).

For example:

- Your name: John Smith
- Company name: Canon
- Company name and department: Canon-Accounting Dept.

When you send a document via e-mail, fax, or I-fax, the unit name that you registered is displayed or printed as the sender's name at the recipient's machine.

Some fax models also display sender information on the touch panel display during transmission.

 **NOTE**

- It is necessary to register a separate Unit Name if you have an additional line. See "Registering the Unit Name for an Additional Line," on p. 9-50.
- If the optional Super G3 FAX Board or Super G3 Multi-Line Fax Board is installed, the unit name can be printed in the TX Terminal ID.
- If SDL or the Local Device Authentication user authentication system of SSO is set as the login service and you are sending an e-mail message:
  - The e-mail address of the login user registered for SDL or the Local Device Authentication user authentication system of SSO is displayed in the From field on the e-mail recipient's machine, instead of the e-mail address registered in the Device Information settings for this machine. (See "Sending an E-Mail Message," on p. 5-5.)
- If SDL or the Local Device Authentication user authentication system of SSO is set as the login service and you are sending an I-fax:
  - The e-mail address that you registered in the Device Information settings for this machine is displayed in the From field on the I-fax recipient's machine, and the e-mail address of the login user registered for SDL or the Local Device Authentication user authentication system of SSO is displayed in the Sender field. (See "Sending an I-Fax," on p. 5-8.)
- If the Domain Authentication user authentication system of SSO (including when performing Domain Authentication with the 'Domain Authentication + Local Device Authentication' user authentication system) is set as the login service and you are sending an e-mail message:
  - The e-mail address that you registered for Active Directory or imageWARE Accounting Manager is displayed in the From field on the recipient's machine, instead of the e-mail address that you registered in the Device Information settings for this machine. (See "Sending an E-Mail Message," on p. 5-5.)
- If the Domain Authentication user authentication system of SSO (including when performing Domain Authentication with the 'Domain Authentication + Local Device Authentication' user authentication system) is set as the login service and you are sending an I-fax:
  - The e-mail address that you registered in the Device Information settings for this machine is displayed in the From field, and the e-mail address that you registered for Active Directory or imageWARE Accounting Manager is displayed in the Sender field on the recipient's machine. (See "Sending an I-Fax," on p. 5-8.)
- For instructions on storing your machine's e-mail address, see the *Network Guide*.

---

**1** Press  (Additional Functions) → [Communications Settings] → [TX Settings] under <Common Settings> → [Unit Name].

**2** Enter a name → press [OK].

# Flow of Sending Operations

---

This section describes the flow of basic sending operations.

 NOTE

- Before using the Send function, it is useful to read the following topics:
  - Main power and control panel power (See Chapter 1, "Before You Start Using This Machine," in the *Reference Guide*.)
  - For instructions on entering characters using the keys displayed on the touch panel display, see Chapter 2, "Basic Operations," in the *Reference Guide*.
  - Routine maintenance (See Chapter 7, "Routine Maintenance," in the *Reference Guide*.)
- The maximum number of send jobs that the machine can handle is 120, including jobs with error codes. Among these, 64 fax jobs can be handled. However, the actual number of send jobs that the machine can handle may be less than 120, depending on the following conditions:
  - Multiple documents are being sent at the same time
  - Large documents are being sent
- You can print a report that contains the results of all send jobs. (See "Send TX Report," on p. 12-4.)
- If you are using a login service, it is necessary to log in to the machine with the appropriate procedure for the login service you are using.
  - If you are using the optional Card Reader-C1 to perform Department ID Management, see Chapter 3, "Optional Equipment," in the *Reference Guide*.
  - If you are using Department ID Management, see Chapter 2, "Basic Operations," in the *Reference Guide*.
  - If you are using the SDL or SSO login service, see Chapter 2, "Basic Operations," in the *Reference Guide*.

## 1 Press [Send].

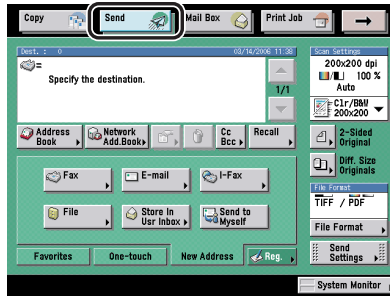

The Send Basic Features Screen

## 2 Place your originals.

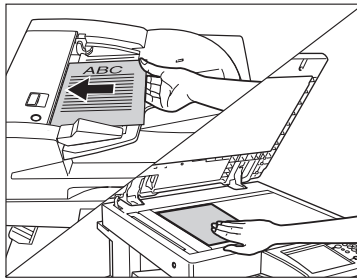









### NOTE

For instructions on placing your originals, see Chapter 2, "Basic Operation," in the *Reference Guide*.

### 3 Specify the destinations.

#### NOTE

- To send documents to a fax destination, the optional Super G3 FAX Board or Super G3 Multi-Line Fax Board is required.
- A maximum of 256 destinations can be specified at the same time. (Out of the 256 destinations, 64 new addresses, including those obtained via a server, can be specified.) If you specify a group, which is made up of several destinations, each destination is counted as a separate address.
- The icons that are displayed on the screen are:
  -  : Group
  -  : E-mail
  -  : I-Fax
  -  : File Server
  -  : Inbox
  -  : Fax
  -  : Cc
  -  : Bcc

#### ● If a destination is stored in the Address Book:

- Press [Address Book] → select the desired destination. (See "Using the Address Book," on p. 2-23.)

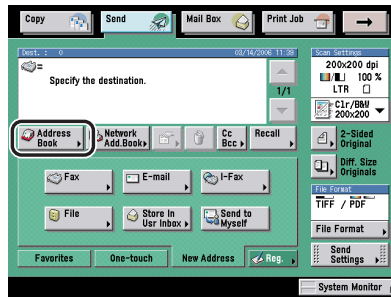

- **If a destination is not stored in the Address Book:**

- Press [New Address] → select a sending method → enter the desired destination. (See "Specifying Destinations Using the New Address Tab," on p. 2-2.)

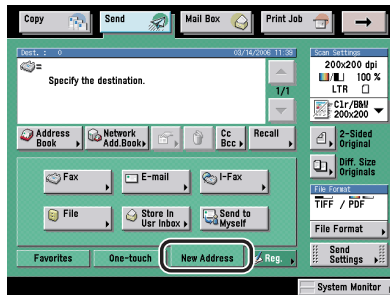

**NOTE**

A maximum of 64 new addresses and addresses obtained via a server (User Inboxes are not included in this count) can be specified at the same time.

- **If a destination is stored in a One-Touch Button:**

- Press [One-touch] → select the one-touch button that contains the desired destination. (See "Using the One-Touch Buttons," on p. 2-25.)

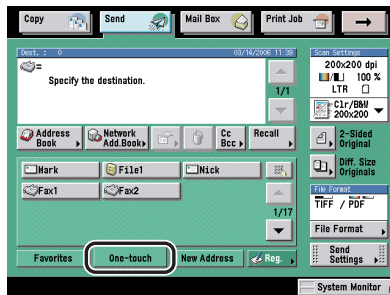

● **If a destination is stored in a Favorites Button:**

- Press [Favorites] → select the favorites button that contains the desired destination. (See "Using the Favorites Buttons," on p. 2-26.)

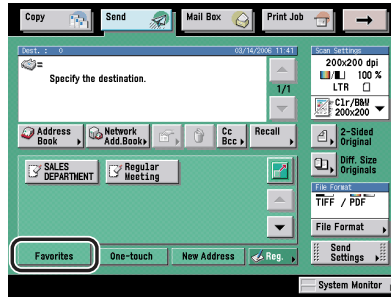

**NOTE**

You can enlarge the Favorites Buttons display by pressing [F5]. (See "Initial Send Screen Display," on p. 9-27.)

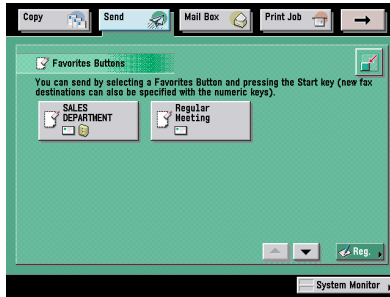

● **If you want to specify a destination using a server:**

- Press [Network Add.Book] → search through the directory listing on the server (LDAP) to specify the destination. (See "Using a Server," on p. 2-27.)

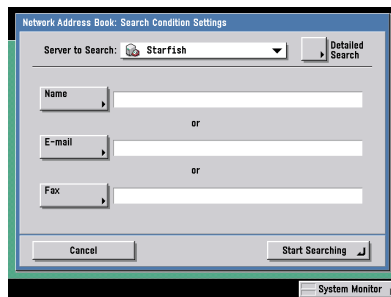

**NOTE**

A maximum of 64 new addresses and addresses obtained via a server (User Inboxes are not included in this count) can be specified at the same time.



**● If you want to specify Cc or Bcc addresses:**

- Press [Cc Bcc] → specify the e-mail addresses. (See "Setting Cc and Bcc Addresses," on p. 2-32.)

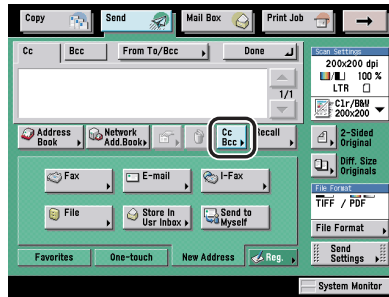
 **NOTE**

- Only e-mail addresses can be specified as cc and bcc addresses.
- A maximum of 64 destinations can be specified for [Cc] and [Bcc], including those obtained using New Address Tab or via a server (User Inboxes are not included in this count). Group Addresses cannot be specified for [Cc] and [Bcc].

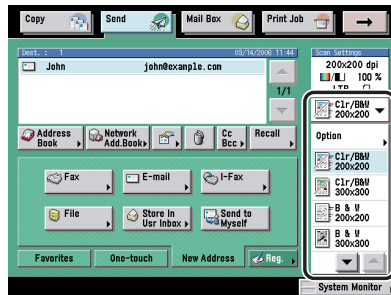
**4 Press the Scan Settings drop-down list → select a scan setting.**

If the desired scan setting is not displayed, press [▼] or [▲] to scroll through the list.

To change the Scan mode settings, select [Option] from the Scan Settings drop-down list, and adjust the settings. (See "Scan Settings," on p. 3-4.)

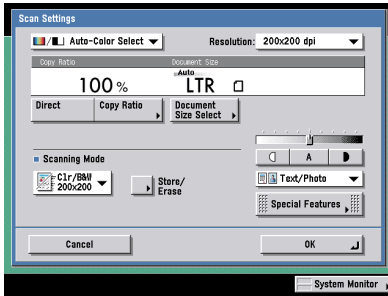

### IMPORTANT

When the Auto-Color Select mode is set and your originals contain color sections, the machine scans them in the Full Color mode. However, the machine may scan the color originals in the Black mode under the following conditions. To avoid this, set the color mode to 'Full Color'. (See "Full Color," on p. 3-22.)

- If the originals contain few color sections
- If the color sections are located only on the left side (within 3/8" (10 mm) from the left edge) of the originals when placing the originals into the feeder
- If the originals contain light color densities
- If the color sections of the originals are close to black



### NOTE

For instructions on setting the Scan mode, see "Selecting a Scan Mode," on p. 3-2.



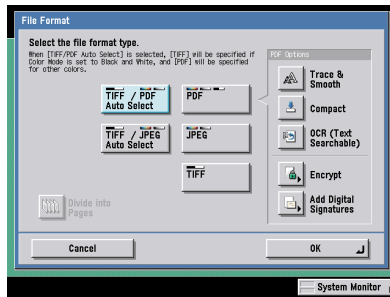
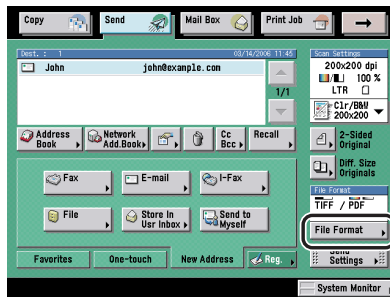



## 5 Press [File Format] → select a file format for sending your document.



This part of the procedure is not necessary if any one of the following is true:

- A fax number is specified as the destination
- An I-fax address is specified as the destination
- A User Inbox is specified as the destination

### NOTE

- For instructions on setting the file format, see "Setting the File Format," on p. 5-22.
- The icons that are displayed on the screen are:
  -  : Divide into Pages
  -  : Trace and Smooth
  -  : Compact
  -  : OCR (Text Searchable)
  -  : Encrypt
  -  : Add Digital Signatures

## 6 Press [Send Settings] → specify the send settings.

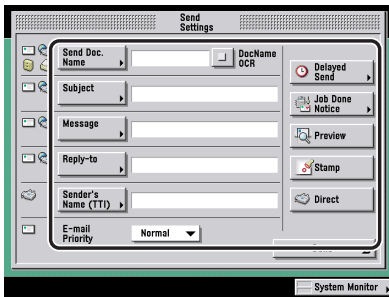
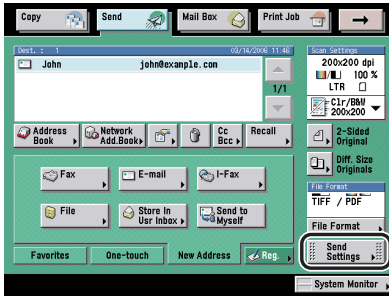

Specify the Delayed Send, Job Done Notice, Preview, Stamp, and Direct Sending modes, as necessary.

### NOTE

- For instructions on specifying the Send Settings, see "Sending Methods," on p. 5-2.
- For instructions on setting the Delayed Send mode, see "Delaying a Send Job," on p. 5-14.
- For instructions on setting the Job Done Notice, see "Job Done Notice," on p. 5-16.
- For instructions on setting the Preview mode, see "Previewing Originals," on p. 5-17.
- For instructions on setting the Stamp mode, see "Stamping Originals," on p. 5-19.
- For instructions on setting the Direct Sending mode, see "Sending a Fax," on p. 5-2.

## 7 Press [Done].

## 8 Press (Start).

If the following screen is displayed, follow the instructions on the touch panel display → press  (Start). When scanning is complete, press [Done].

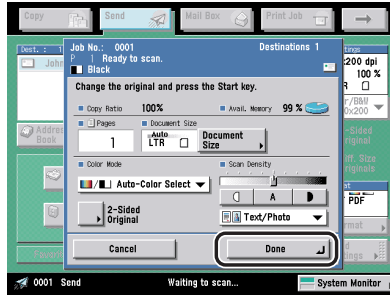

If the following screen is displayed, press [OK] → try scanning the original again from the first page. Scanning may be possible if you set 'Low' for Sharpness, and 'Text' for the type of original.



Scanning starts.

The scanned data is sent to the specified destination when scanning is complete.

### IMPORTANT

The size of the original is detected automatically. However, if the output paper in the recipient's machine is not equal to the scanned document size, the original image may be reduced in size to match it.

### NOTE

If [Preview] on the Send Settings screen is set, you can verify the images from the Preview screen before sending your document. (See "Previewing Originals," on p. 5-17.)

## 9 If you want to cancel sending, press (Stop).

### NOTE

- You can press  (Stop) to cancel a send job that is being scanned.
- For instructions on canceling a send job, see "Canceling a Job," on p. 1-35.
- You can also cancel a send job from the System Monitor screen. (See "Using the System Monitor Screen," on p. 1-36.)

## 10 When scanning is complete, remove your originals.

# Sending Fax Documents Manually

This mode enables you to manually send fax documents after checking that the destination is ready to receive fax transmissions.

## IMPORTANT

- If the optional Super G3 Multi-Line Fax Board is installed, manual sending can only be used for line 1.
- Manual sending enables you to send a document consisting of two or more pages only if you use the feeder to send it. You can only send one page at a time when you place your originals on the platen glass.
- If you cancel manual sending during transmission, the pages that have already been scanned are sent. You can check how many pages have been sent to the destination by printing a Fax Activity Report, or on the Log screen for Fax on the System Monitor screen.

## NOTE

This mode is available only if the optional Super G3 FAX Board or Super G3 Multi-Line Fax Board is installed.

## **1** Place your originals.

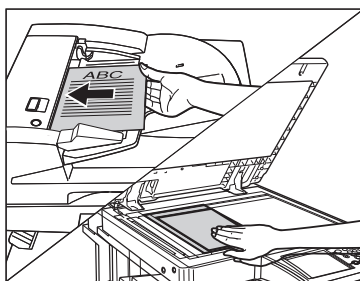

## 2 Make sure that the machine is ready to send.

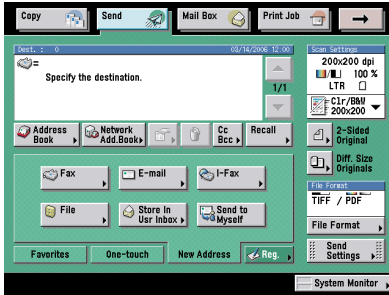

## 3 Press [New Address] → [Fax].

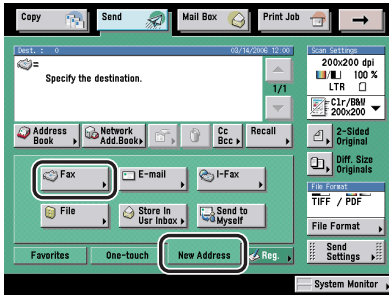

## 4 Press [On-hook].

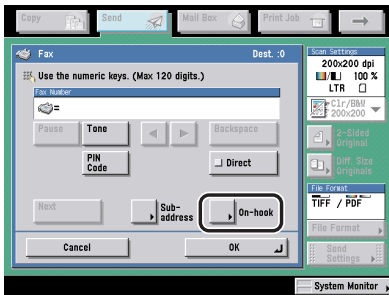



## 5 Enter the recipient's fax number using 0 - 9 (numeric keys), \*, and #.

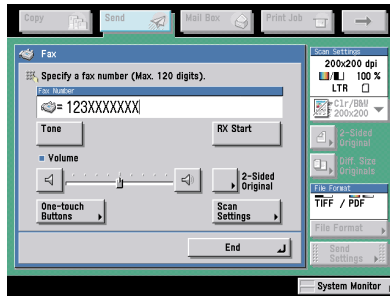

If you pressed [One-touch Buttons], select the desired one-touch button → press [OK].

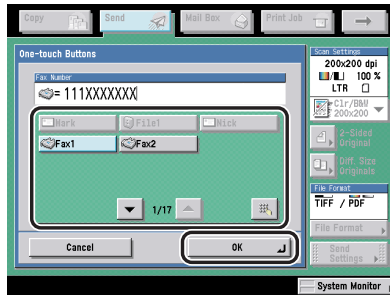

If you know the one-touch button's three digit number, press [F##] (One-touch Button Number) → enter the number for the desired one-touch button using 0 - 9 (numeric keys).

### IMPORTANT

Make sure that you hear the dial tone before entering the fax number. If you enter the fax number before hearing the dial tone, the call may not be connected, or an incorrect number may be dialed.

### NOTE

For instructions on specifying addresses using the one-touch buttons, see "Using the One-Touch Buttons," on p. 2-25.

## 6 Make sure that you hear the other party or carrier signal (a high-pitched tone).

The level of the dial tone can be adjusted by pressing [F1] or [F2].

You can enter an extension number after dialing the fax number.

 **NOTE**

- You can change the scan settings before sending your document. (See Chapter 3, "Basic Scanning Features," and Chapter 4, "Special Scanning Features.")
- To cancel Manual Sending, press [End].

## **7** Press **(Start).**

Scanning starts and the document is sent.

During the transmission, the transaction number, destination's telephone number, and page number are displayed in the message area.

# Canceling a Job

You can cancel a send job using the touch panel display, System Monitor screen, or by pressing  (Stop) on the control panel.

## Using the Touch Panel Display

You can cancel a send job by pressing [Cancel], while the job is being scanned.

- 1 Press [Cancel] on the pop-up screen that appears while the machine is scanning.**

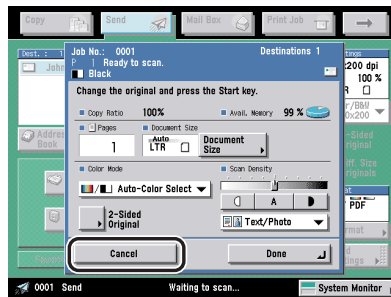

The send job is canceled.

- 2 Remove your originals.**

## Using the Stop Key

You can cancel a send job by pressing  (Stop), while the job is being scanned.

### NOTE

You can press  (Stop) only to cancel a send job that is being scanned.

### 1 Press (Stop).

The send job is canceled.

### 2 Remove your originals.

## Using the System Monitor Screen

You can cancel a send job while it is waiting to be processed, or while it is being sent.

### *E-mail, I-Fax, Sending to a File Server, or Storing in a User Inbox*

### 1 Press [System Monitor].

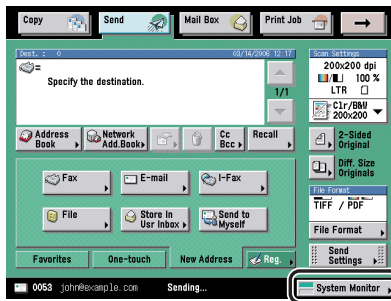

## 2 Press [Send].

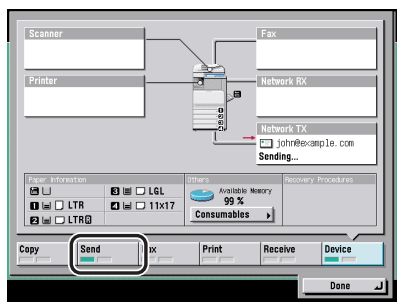

## 3 Press [Status] → select the send job that you want to cancel → press [Cancel].

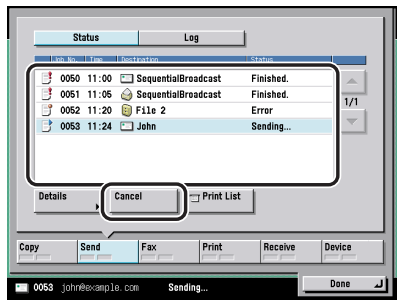

You cannot select multiple jobs and cancel them all at once. Select and cancel one job at a time.

If a job is in the process of being sent, it may not be canceled even if you press [Cancel].

## 4 Press [Yes].

### NOTE

The canceled job is displayed as <NG> (No Good) on the Log screen.

# Fax

## 1 Press [System Monitor].

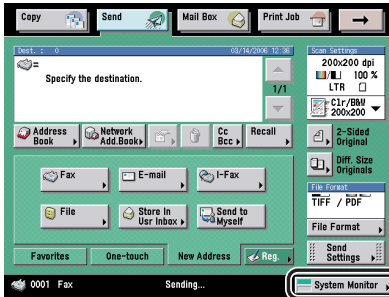

## 2 Press [Fax].

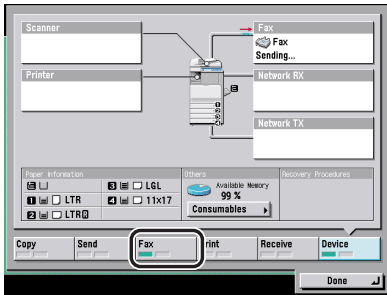

## 3 Press [Send Job Status] or [Received Job Status] → select the fax job that you want to cancel → press [Cancel].



You cannot select multiple jobs and cancel them all at once. Select and cancel one job at a time.

If a job is in the process of being sent, it may not be canceled even if you press [Cancel].

## 4 Press [Yes].

### ● To cancel a Sequential Broadcast:

- Verify the destinations of the fax job, press [Cancel All] or [Cancel Current Job].  
If you do not want to cancel any job of the Sequential Broadcast, press [Cancel].



### NOTE

The canceled job is displayed as <NG> (No Good) on the Log screen.





# 2

## CHAPTER

# Basic Sending Methods

This chapter describes how to specify, check, change, and erase destinations.

---

Specifying Destinations Using the New Address Tab . . . . .	2-2
Specifying a Fax Number . . . . .	2-2
Specifying an E-Mail Address . . . . .	2-6
Specifying an I-Fax Address . . . . .	2-7
Specifying a File Server . . . . .	2-11
Specifying a User Inbox . . . . .	2-20
Sending Documents to Yourself . . . . .	2-22
Specifying Registered Destinations . . . . .	2-23
Using the Address Book . . . . .	2-23
Using the One-Touch Buttons . . . . .	2-25
Using the Favorites Buttons . . . . .	2-26
Using a Server . . . . .	2-27
Setting Cc and Bcc Addresses . . . . .	2-32
Checking/Changing a Destination . . . . .	2-34
Erasing a Destination . . . . .	2-36
Registering New Destinations Using the Register Key . . . . .	2-37

# Specifying Destinations Using the New Address Tab

You must specify the destination (such as a fax number, e-mail address, I-fax address, or file server address) to send documents. This section describes the procedure for specifying destination that has not been stored in the Address Book.





## IMPORTANT

The destination that you just specified is not stored in the Address Book. It is deleted once the document is sent.

## NOTE





- If you frequently send documents to the same destinations, store these destinations in the Address Book beforehand. (See "Storing New Addresses," on p. 10-5.)
- A maximum of 64 new addresses and addresses obtained via a server (User Inboxes are not included in this count) can be specified at the same time.
- You can specify e-mail addresses, I-fax addresses, file server addresses, and a User Inbox.
- If the optional Super G3 FAX Board or Super G3 Multi-Line Fax Board is installed, you can specify fax numbers in addition to the above mentioned destinations.
- To view the detailed information of a selected destination, select the destination → press [Details].
- You can change, edit, or erase destinations on the Send Basic Features screen before scanning. (See "Checking/Changing a Destination," on p. 2-34, or "Erasing a Destination," on p. 2-36.)

## Specifying a Fax Number

You can specify a new fax number using  -  (numeric keys), , and . You can also specify several numbers in succession, and send the original to several destinations in a single operation (Sequential Broadcast).

### **1** Press [New Address] → [Fax].

#### NOTE

If no destination is displayed on the Send Basic Features screen, pressing  -  (numeric keys), , or  without pressing [Fax] on the New Address tab, displays the screen shown in step 2, which enables you to enter the fax number.

## 2 Enter the recipient's fax number using 0 - 9 (numeric keys), \*, and #.

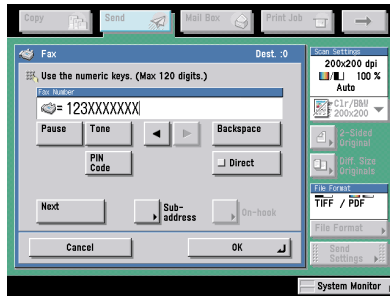

Details of each item are shown below.

- [Pause]: Press to insert a pause of several seconds in the fax number that you are dialing. If you insert a pause, the letter <p> is displayed between the numbers, and the letter <P> appears at the end of the number. When dialing an overseas number, insert a pause after the country code, and at the end of the telephone number. (See "Pause Time," on p. 9-44.)
- [Tone]: Press when you want to directly call an extension line that is connected to a PBX (Private Branch eXchange) which accepts only tone signals. If you press [Tone], the letter <T> appears. (See "Fax Information Services," on p. 7-8.)
- [<|>]: Press to move the position of the cursor.
- [Backspace]: Press to delete the last number entered.
- [PIN Code]: Press to enter the PIN (Personal Identification Number) code. You can press this key only if [Option] is selected for PIN code position. If [Prefix], [Suffix], or [Off] is selected for PIN code position, this key is grayed out. (See "Using a PIN Code," on p. 7-5.)
- [Direct]: Press to send documents directly to the recipient. If you do not select Direct Sending mode, Memory Sending mode is used. (See "Sending a Fax," on p. 5-2.)
- [Next]: Press to specify another destination after specifying the first destination using the numeric keys.
- [Option]: Displayed if the optional Super G3 Multi-Line Fax Board is installed. Press to set the subaddress and password, or to select the line type of the additional line.
- [Subaddress]: Press to set an optional subaddress and password.

[On-hook]: Press to use tone dialing or to send a fax document manually. (See "Sending Fax Documents Manually," on p. 1-31, or "Fax Information Services," on p. 7-8.)



### IMPORTANT

You cannot insert a pause at the beginning of a number.



### NOTE

If you enter a pause at the end of the number, the pause is always 10 seconds long.

### ● If you press [Option]:

Press [Subaddress] → enter the recipient's subaddress using 0 - 9 (numeric keys), \*, and #.

Press [Password] → enter the recipient's password using 0 - 9 (numeric keys), \*, and #.

Press [Space] to insert a space.

Press [Backspace] to delete the last digit entered.

If the recipient did not set a password for the target subaddress, you do not need to enter a password.



### IMPORTANT

If you want to attach a subaddress to your send job, make sure that the recipient's fax machine supports ITU-T (International Telecommunication Union - Telecommunication Standardization Sector) standard subaddresses.



### NOTE

For instructions on sending documents with a subaddress, see "Sending with a Subaddress," on p. 7-2.

Select [Line 1], [Line 2], or [Auto] → press [OK].

Details of each item are shown below.

[Line 1]: Standard line

[Line 2]: Additional line

[Auto]: Selects the line according to the settings specified for [TX Line Selection] in [Dual Line Options] under <Fax Settings> in Communications Settings (from the Additional Functions screen). (See "Selecting the Line for Sending," on p. 9-52.)

 **IMPORTANT**

- You can restrict sending from line 1 or line 2. (See "Selecting the Line for Sending," on p. 9-52.)
- When using manual sending, line 1 is automatically selected, regardless of the line settings.
- When [Auto] is selected for <Line Selection>, the user name displayed/printed on the recipient's machine will be the user name registered for the line which was used for sending.

**● If you press [Subaddress]:**

- Press [Subaddress] → enter the recipient's subaddress using 0 - 9 (numeric keys), \*, and #.
- Press [Password] → enter the recipient's password using 0 - 9 (numeric keys), \*, and #.
- Press [OK].

Press [Space] to insert a space.

Press [Backspace] to delete the last digit that you entered.

If the recipient did not set a password for the target subaddress, you do not need to enter a password.

 **IMPORTANT**

If you want to attach a subaddress to your send job, make sure that the recipient's fax machine supports ITU-T (International Telecommunication Union - Telecommunication Standardization Sector) standard subaddresses.

 **NOTE**

For instructions on sending documents with a subaddress, see "Sending with a Subaddress," on p. 7-2.

**3 Press [OK].**

## Specifying an E-Mail Address

You can specify a new e-mail address. You can enter an e-mail address directly from the keyboard on the touch panel display.

**1** Press [New Address] → [E-mail].

**2** Press [E-mail Address].

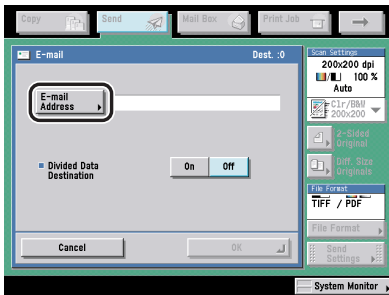

**3** Enter the e-mail address → press [OK].

**4** Select [On] or [Off] for <Divided Data Destination>.

Details of each item are shown below.

[On]: Select [On] if the destination's e-mail software has a function to combine divided data. If the size of the data being sent exceeds the value set for Maximum Data Size for Sending in E-mail/I-Fax Settings in Communications Settings in System Settings (from the Additional Functions screen), the data is divided into multiple parts before being sent. Once the destination machine receives all of the parts of the data, it combines them into one item of data.

[Off]: Select [Off] if the destination's e-mail software has no function to combine divided data. If the size of the data being sent exceeds the value set for Maximum Data Size for Sending in E-mail/I-Fax Settings in Communications Settings in System Settings (from the Additional Functions screen), the data is divided into separate pages and sent as multiple e-mail messages.

**IMPORTANT**

Make sure to check the specifications of the destination's e-mail software before setting this mode. A sending error may occur if the destination's e-mail software is not able to combine divided data.

**NOTE**

For more information on the maximum data size for sending, see "E-Mail/I-Fax Settings," on p. 11-4.

**5 Press [OK].**

## Specifying an I-Fax Address

You can specify a new I-fax address. Regardless of the distance and area, I-fax helps you to reduce transmission costs by making transactions via the Internet. You can enter an I-fax address directly from the keyboard on the touch panel display. You can also specify the scan settings and the settings at the destination when using I-fax.

**1 Press [New Address] → [I-Fax].**

**2 Press the Mode drop-down list → select [Simple] or [Full].**

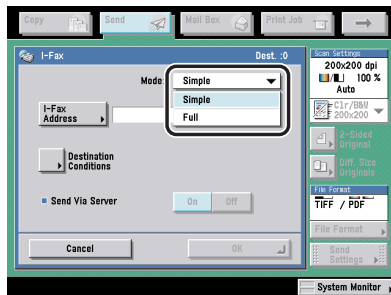

Details of each item are shown below.

[Simple]: Sends scanned data as an image via the Internet.

[Full]: Sends scanned data as an image via the Internet, and enables you to receive a delivery confirmation message telling you whether your I-fax was sent successfully.

 NOTE

- In order for you to receive a confirmation message telling you the delivery status of your I-fax document, the recipient's machine must have I-fax capabilities and be compatible with the Full mode.
- If you send documents using the Full mode to a machine that does not support the Full mode, delivery confirmation cannot be carried out. When this happens, the job concerned is not considered as complete even though the actual sending of the document is successful. Such jobs are displayed as <Waiting for result...> on the Status screen until the time set for <Full Mode TX Timeout> in E-mail/I-Fax Settings in Communications Settings in System Settings (from the Additional Functions screen) has lapsed. After the timeout, the job is moved to the log, and the result is shown as <-> when sending of the document to a server or other destination could not be verified.

### 3 Press [I-Fax Address].

### 4 Enter the I-fax address → press [OK].

 NOTE

If you do not send documents via a server, and the recipient's IP address is not registered on a DNS server, use the following format to enter the domain name: (user)@(the recipient's IP address).

### 5 Press [Destination Conditions] → specify the receiving conditions of the destination.

### 6 Select [On] or [Off] for <Receive Divided Data>.

Details of each item are shown below.

[On]: Select [On] if the destination machine has a function to combine divided data. If the size of the data being sent exceeds the value set for Maximum Data Size for Sending in E-mail/I-Fax Settings in Communications Settings in System Settings (from the Additional Functions screen), the data is divided into multiple parts before being sent. Once the destination machine receives all the parts of the data, it combines them into one item of data.

[Off]: Select [Off] if the destination machine has no function to combine divided data. If the size of the data being sent exceeds the value set for Maximum Data Size for Sending in E-mail/I-Fax Settings in Communications Settings in System Settings (from the Additional Functions screen), a sending error occurs.



 **IMPORTANT**

Set the destination conditions according to the specifications of the recipient's machine. An error in transmission may occur if you set conditions that the recipient's machine does not support.

 **NOTE**

For more information on the maximum data size for sending, see "E-Mail/Fax Settings," on p. 11-4.

## 7 Select [On] or [Off] for <Receive in Color>.

### ● If you want to send in black-and-white:

- Press [Off] for <Receive in Color>.
- Select the paper size, compression method, and resolution → press [OK].

The following conditions are always selected:

- Paper Size: A4/LTR
- Compression Method: MH (Modified Huffman)
- Resolution: 200 x 100 dpi and 200 x 200 dpi

LTR, LGL, and STMT are included in [A4/LTR].

 **IMPORTANT**

Set the destination conditions according to the specifications of the recipient's machine. An error in transmission may occur if you set conditions that the recipient's machine does not support.

 **NOTE**

Available compression methods are:

- MH (Modified Huffman) - a coding system that horizontally scans and compresses extended areas of white and black dots.
- MR (Modified Read) - a coding system that horizontally and vertically scans and compresses white and black areas. Faster than MH.
- MMR (Modified Modified Read) - an adaptation of Modified Read, originally for use in digital machines. Faster than MR.

### ● If you want to send in color:

- Press [On] for <Receive in Color> → press [Next].
- Select the paper size and resolution → press [OK].

The following conditions are always selected:

- Paper Size: A4/LTR
- Resolution: 200 x 200 dpi

LTR, LGL, and STMT are included in [A4/LTR].

 **IMPORTANT**

Set the destination conditions according to the specifications of the recipient's machine. An error in transmission may occur if you set conditions that the recipient's machine does not support.

## 8 Select [On] or [Off] for <Send Via Server>.

Details of each item are shown below.

[On]: Sends your I-fax documents via a mail server. This enables you to send documents to destinations via the Internet in the same way that you send an e-mail message.

[Off]: Does not send your I-fax documents via a server. You can send large amounts of image data to a recipient within the same LAN (Local Area Network) environment without placing a burden on the mail server. This enables you to send documents quickly and directly to the recipient. To use this setting, it is necessary to set up an MX (Mail eXchange) record on the DNS server. Ask your System Manager whether this type of sending is possible before you set <Send Via Server> to 'Off'.

 **IMPORTANT**

To be able to specify the Send Via Server setting, set <Use Send Via Server> to 'On' on the E-mail/I-Fax Settings screen beforehand. It is recommended to set <Allow MDN Not Via Server> to 'On' on the same screen. To access the E-mail/I-Fax Settings screen, press  (Additional Functions) → [System Settings] → [Communications Settings] → [E-mail/I-Fax Settings]. If <Use Send Via Server> is set to 'Off', <Send Via Server> is grayed out. (See "E-Mail/I-Fax Settings," on p. 11-4.)

 **NOTE**

Even if <Send Via Server> is set to 'Off', delivery confirmation of documents sent using the Full mode is carried out via the server.

## 9 Press [OK].

# Specifying a File Server

This section describes the four procedures for specifying a file server on the network as the destination of a send job.



## IMPORTANT

- Windows 2000/XP/Server 2003 restricts the number of users or clients that can be accessed. Once the limit of users or clients has been reached, it is not possible to send documents to a file server using Windows 2000/XP/Server 2003.
- If Language Switch in Common Settings (from the Additional Functions screen) is set to 'On', the Host Name and File Path of the file server destination may not be displayed correctly, so you may not be able to refer to them.



## NOTE

- Set the following items when sending to a file server:
  - Protocol
  - Host Name
  - File Path
  - User
  - Password
- For examples of the settings that are needed to send documents to a file server, see the *Network Guide*.
- If you are sending to an imageWARE Document Manager folder, set the FTP server address specified in imageWARE Gateway as the destination. Using imageWARE Document Manager and the Send function of the Color imageRUNNER enables you to manage digitized paper documents and computer data on the network. For more information on imageWARE Document Manager, see the appropriate imageWARE Gateway documentation.

## ■ Using the Keyboard

You can specify a file server as the destination directly from the keyboard displayed on the touch panel display. Press [Host Name], [File Path], [User], and [Password] to specify the file server settings.

## ■ Using the Browse Key (Windows (SMB))

If you select [Windows (SMB)] as the server protocol, you can specify a file server connected to a specific network by pressing [Browse] on the File screen.

## ■ Using the Browse Key (NetWare (IPX))

If you select [NetWare (IPX)] as the server protocol, you can specify a file server connected to a specific network by pressing [Browse] on the File screen.

## ■ Using the Host Search Key (Windows (SMB))

If you select [Windows (SMB)] as the protocol, you can specify a file server connected to a specific network by pressing [Host Search] on the File screen.

## Using the Keyboard

- 1 Press [New Address] → [File].
- 2 Press the Protocol drop-down list → select the desired server protocol.

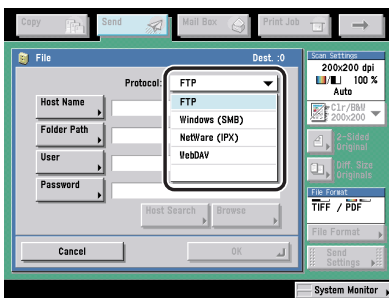

The following server protocols may be used.

Confirm the system environment of the destination before sending.

Protocol	System Requirements	Application
FTP	Sun Solaris V.2.6 or later, Mac OS X or later, or Red Hat Linux 7.2	—
	Windows 2000 Server	Internet Information Services 5.0
	Windows XP Professional	Internet Information Services 5.1
Windows (SMB)	Windows 98/Me/2000/XP or Windows Server 2003	—
	Mac OS v10.2 Red Hat Linux 7.2	Samba 2.2/3.0
NetWare (IPX)	Novell NetWare V.3.2 or later	—

Protocol	System Requirements	Application
WebDAV	Sun Solaris V.2.6 or later, Red Hat Enterprise Linux AS/ES/WS 4.0 or later, Windows 2000 Server, Windows XP Professional, or Windows Server 2003	Apache 2.0
	Mac OS X	Apache 1.3
	Windows 2000 Professional/Server	Internet Information Services 5.0
	Windows XP Professional	Internet Information Services 5.1
	Windows Server 2003	Internet Information Services 6.0

### 3 Specify each setting → press [OK].

If you select [Windows (SMB)] or [NetWare (IPX)] as the server protocol, you can specify the file server by pressing [Browse]. For instructions on using the Browse key, see "Using the Browse Key (Windows (SMB))," on p. 2-14, or "Using the Browse Key (NetWare (IPX))," on p. 2-16.

If you select [Windows (SMB)] as the server protocol, you can specify the file server by pressing [Host Search]. For instructions on using the Host Server key, see "Using the Host Search Key (Windows (SMB))," on p. 2-19.

[Host Name]:

Press [Host Name] → enter a host name → press [OK].

A host name is a name assigned to a host computer that provides services on the Internet. A specific host name is assigned to each host computer to identify it on the Internet. In this entry box, enter the name of the file server on the network as the destination of the send job.

When [FTP] or [WebDAV] is selected as the server protocol, you can also specify a port number after the host name address by entering a colon (:) and the port number.

Example: 192.168.100.50:21000

When [FTP] is selected as the server protocol, make sure to enter the same port number for the Host Name as the one specified for the FTP server to which you are sending your documents.

When [WebDAV] is selected as the server protocol, the HTTP protocol is used if you specify 'HTTP:/' as the scheme at the start of the host name, and the SSL + HTTP (HTTPS) protocol is used if you specify 'HTTPS:/' as the scheme at the start of the host name. Specifying 'HTTPS:/' as the scheme enables SSL communications between the server and the machine. However, the route between the server and the machine is only encrypted, and a server certificate validity check is not performed using a CA certificate.

[File Path]:

Press [File Path] → enter a file path → press [OK].

A file path is a series of characters that signify the location of the folder. Specify a folder in the file server as the destination of the send job.

[User]:

Press [User] → enter the user name → press [OK].

If [Windows (SMB)] is selected as the server protocol, enter the required user name information in the manner shown below:

- To enter the user name only  
Example: user\_name  
Maximum 20 characters
- To enter the user name and the domain name  
Example: domain\_name\user\_name  
Domain name: Maximum 15 characters  
User name: Maximum 20 characters
- To enter a UPN (User Principal Name)  
Example: user\_name@domain\_name.com  
Maximum 128 characters

[Password]:

Press [Password] → enter a password → press [OK].

Setting the password is optional.

After pressing [OK], the password appears as asterisks (\*\*\*\*\*) on the File settings screen.



#### NOTE

- If you are sending to an imageWARE Document Manager folder, enter the folder name set in imageWARE Gateway.
- If you are sending to an imageWARE Document Manager folder, enter the user name set in imageWARE Gateway.
- UPN (User Principal Name) can be used only if you are sending to a computer belonging to a domain operated with Active Directory.
- If you are sending to an imageWARE Document Manager folder, enter the password set in imageWARE Gateway.
- When sending to a file server on the Internet using WebDAV, proxy server settings may be required, depending on the environment of the destination. Specify the host name (or IP address), port number, user name, and password for the proxy server in Network Settings in System Settings (from the Additional Functions screen). (For more information, see Chapter 3, "Using a TCP/IP Network," in the *Network Guide*.)

## Using the Browse Key (Windows (SMB))

### 1 Press [New Address] → [File].

## 2 Press the Protocol drop-down list → select [Windows (SMB)].

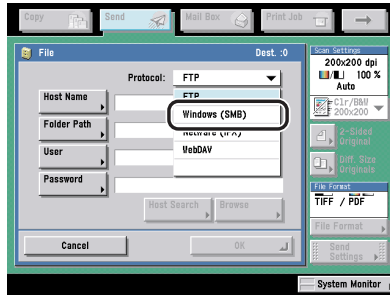

## 3 Press [Browse].

### IMPORTANT

After turning the main power ON, you must wait for the time set in Startup Time Settings to elapse before pressing [Browse]. Network transmission is not possible until this startup time has elapsed. (See Chapter 3, "Using a TCP/IP Network," in the *Network Guide*.)

## 4 Select the desired workgroup → press [Down].

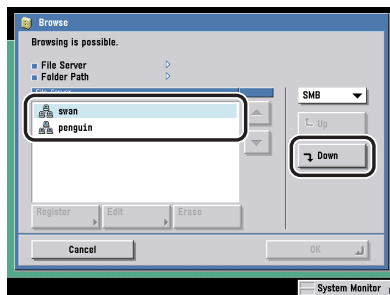

You can also select the workgroup from a list of Active Directory server domain names that are registered in the machine by pressing [Directory] from the drop-down list.

### ● If you want to register a Directory server domain name:

- Press [Register].
- Enter a domain name → press [OK].

 NOTE

- You can register up to five Directory servers.
- To edit the domain name, select the domain name that you want to edit → press [Edit].
- To delete the domain name, select the domain name that you want to delete → press [Erase] → press [Yes] on the pop-up screen that appears when you press [Erase].

**5 Select the desired file server → press [Down].**

To move up one level, press [Up].

**6 If the Enter Network Password screen is displayed, enter your user name and network password.**

- Specify each setting → press [OK].

[User]:

Press [User] → enter your user name → press [OK].

[Password]:

Press [Password] → enter your network password → press [OK].

After pressing [OK], the password that you entered appears as asterisks (\*\*\*\*\*) on the Enter Network Password screen.

 IMPORTANT

Searching for a destination via an LDAP server is not possible if the time setting of the server and the time setting of the machine are more than five minutes apart. If you cannot send even when the user name and password are correct, check the time settings on the server and the machine.

**7 Press [Down] → select the folder on the specified server to which you want to send your documents → press [OK].**

To go down one level, press [Down].

To move up one level, press [Up].

**8 Confirm your settings → press [OK].*****Using the Browse Key (NetWare (IPX))*****1 Press [New Address] → [File].**



## 2 Press the Protocol drop-down list → select [NetWare (IPX)].

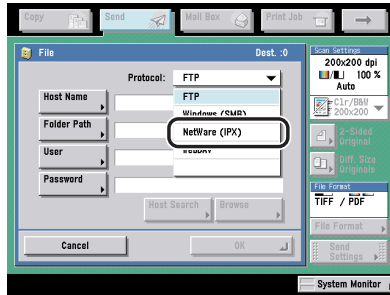

## 3 Press [Browse].

### IMPORTANT

After turning the main power ON, you must wait for the time set in Startup Time Settings to elapse before pressing [Browse]. Network transmission is not possible until this startup time has elapsed. (See Chapter 3, "Using a TCP/IP Network," in the *Network Guide*.)

## 4 Press the drop-down list → select [NDS] or [Bindery] from the drop-down list.

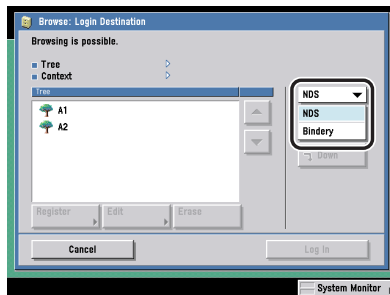

Details of each item are shown below.

[NDS]: NDS (Novell Directory Service) is a directory service that manages user and server names. Select [NDS] when you are using Novell NetWare V.4. x or later.

[Bindery]: One of the directory services provided by Novell for managing the information of user and server names. Select [Bindery] when you are using Novell NetWare V.3.x.

If you select [Bindery], follow the procedure from step 5 in "Using the Browse Key (Windows (SMB))," on p. 2-14.

If you select [NDS], follow the steps below.

## 5 Select the desired NDS tree → press [Down].

To move up one level, press [Up].

## 6 Select a folder on the specified server in which you want to log on to → press [Log In].

If no folder is displayed, press [Log In] to log on to the Novell server.

To go down one level, press [Down].

To move up one level, press [Up].

## 7 Enter your user name and network password.

Specify each setting → press [OK].

[User]:

Press [User] → enter your user name → press [OK].

[Password]:

Press [Password] → enter your network password → press [OK].

After pressing [OK], the password that you entered appears as asterisks (\*\*\*\*\*) on the Enter Network Password screen.



### IMPORTANT

Searching for a destination via an LDAP server is not possible if the time setting of the server and the time setting of the machine are more than five minutes apart. If you cannot send even when the user name and password are correct, check the time settings on the server and the machine.

## 8 Press [Down] → select the folder to where you want to send your file → press [OK].

To move up one level, press [Up].

## 9 Confirm your settings → press [OK].

## Using the Host Search Key (Windows (SMB))

**1** Press [New Address] → [File].

**2** Press the Protocol drop-down list → select [Windows (SMB)].

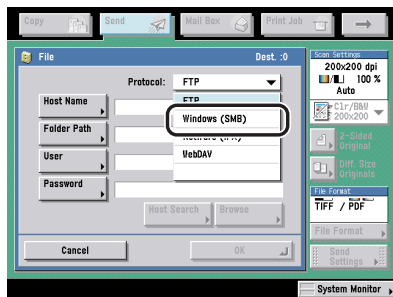

**3** Press [Host Search].

**4** Enter the search conditions → press [Start Searching].

[Workgroup]:

Press [Workgroup] → enter the workgroup name → press [OK].

[Host Name to Search]:

Press [Host Name to Search] → enter the IP address, FQDN, or NetBIOS name → press [OK].



### NOTE

- When entering a NetBIOS name, you can also enter wildcard characters, such as \* and ?, as part of your search.
- When searching for the host name using wildcard characters, make sure to also enter a workgroup name.

#### • Examples

- \* (asterisk): Replaces one or more characters (up to 15 characters).

Example: tri\* → trinity  
trinity1  
trinity0002

- ?: Replaces one only character.

Example: tr?nity → trinity

## 5 Select the file server from the search results.

### ● If there are search results:

- Specify the file server in accordance with steps 5 to 7 of "Using the Browse Key (Windows (SMB))," on p. 2-14.

### ● If there are no search results:

- Specify the file server in accordance with steps 4 to 7 of "Using the Browse Key (Windows (SMB))," on p. 2-14.

## 6 Confirm your settings → press [OK].

## Specifying a User Inbox

You can store a scanned document in a User Inbox. If you include a User Inbox as one of the destinations to which you are sending your document, the document is stored in the selected User Inbox for later use. Documents stored in a User Inbox can be printed and sent to other destinations.



### IMPORTANT

- Documents that are scanned using a paper size specified by pressing [Other Size] or [Long Strip Original] in Document Size Select, cannot be stored in a User Inbox.
- Documents stored in a User Inbox are automatically erased after three days. However, you can change this setting. (See Chapter 8, "Customizing Settings," in the *Copying and Mail Box Guide*.)

---

## 1 Press [New Address] → [Store In Usr Inbox].

## 2 Select the desired User Inbox → press [OK].

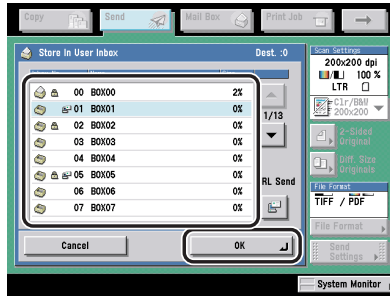

User Inboxes specified as destinations correspond to the inboxes that appear on the Inbox Selection screen for the Mail Box function.

### ● If you want to send a link to a User Inbox via e-mail:

- Press [URL Send].

If you set the machine to send a link via e-mail to the User Inbox in which the document is stored, you can check or perform operations on the document in the User Inbox, using the Remote UI (User Interface) of the machine.

A message <User Inbox Incoming Notice> is inserted into the body of the e-mail message stating the link to the User Inbox.

### NOTE

- Only one User Inbox can be specified as the destination at a time.
- To be able to send a link via e-mail, it is necessary to register an e-mail address in the User Inbox beforehand. For instructions on storing an e-mail address in the machine, see Chapter 8, "Customizing Settings," in the *Copying and Mail Box Guide*.
- If the URL Send mode is set, and you specify a group destination that includes a User Inbox as a send destination, the error message <Cannot send when an inbox is included in the Group Address for [URL Send]. Please enter the settings again.> may be displayed.

## Sending Documents to Yourself

If SDL or the Local Device Authentication user authentication system of SSO is set as the login service, you can press [Send to Myself] to specify your e-mail address (registered in SDL or the Local Device Authentication user authentication system of SSO) as the destination.

### IMPORTANT

- If SDL or the Local Device Authentication system of SSO is set as the login service, your e-mail address registered in SDL or the Local Device Authentication system of SSO is set as the destination.
- If the Domain Authentication system of SSO (including when performing domain authentication with the 'Domain Authentication + Local Device Authentication' system) is set as the login service, your e-mail address registered in Active Directory or imageWARE Accounting Manager is set as the destination.
- For more information on the SDL and SSO login services, see Chapter 2, "Basic Operations," in the *Reference Guide*.

## 1 Press [New Addresses] → [Send to Myself].

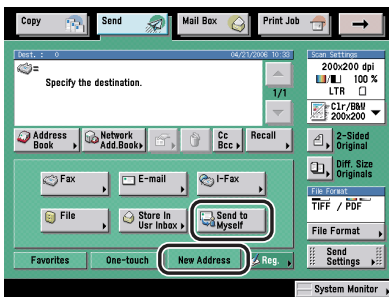

# Specifying Registered Destinations

You can select a destination stored in the Address Book or a one-touch button, or specify a new address altogether. You can also recall the destinations and settings stored in the favorites buttons to check their contents, edit them, or delete them.

## NOTE

- To view the detailed information of a selected destination, select the destination → press [Details].
- You can change, edit, or erase destinations on the Send Basic Features screen before scanning. (See "Checking/Changing a Destination," on p. 2-34, "Erasing a Destination," on p. 2-36.)
- A maximum of 256 destinations can be specified at the same time. (Out of the 256 destinations, 64 new addresses, including those obtained via a server, can be specified.) If you specify a group, which is made up of several destinations, each destination is counted as a separate address.

## Using the Address Book

You must specify the destination (such as a fax number, e-mail address, I-fax address, or file server address) to send documents. If you store addresses in the Address Book, you can easily select them. Addresses are stored in Address Book Settings (from the Additional Functions screen). (See "Storing New Addresses," on p. 10-5.)

## NOTE

Address Books can be saved, imported, and transferred using the Remote User Interface. (See Chapter 2, "Checking and Managing Functions," and Chapter 3, "Customizing Settings," in the *Remote UI Guide*.)

### **1** Press [Address Book].

## 2 Select the destination → press [OK].

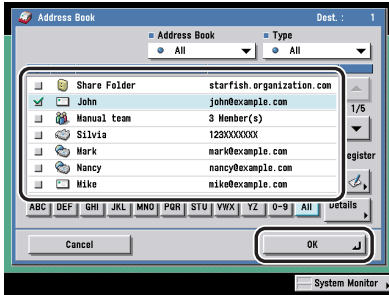

You can select multiple destinations.

Press the alphanumeric keys (e.g., [ABC]) to display the individual keys for each letter or number. You can select a letter or number to restrict the displayed range of entries. Press [All] to return to the full address list.

You can restrict the type of destinations displayed in the result list by pressing the Type drop-down list.

Press the Address Book drop-down list to display a list of subaddress books 1 to 10 or one-touch buttons. Subaddress books categorize the addresses stored in the Address Book.

You can specify e-mail addresses, I-fax addresses, file server addresses, and group addresses.

If the optional Super G3 FAX Board or Super G3 Multi-Line Fax Board is installed, you can also specify fax numbers in addition to the above mentioned destinations.

If you select a destination that is stored with an access number, press [Access Number] and then enter the access number using 0 - 9 (numeric keys). If you press [No Access Number], the destinations that are not managed with an access number are displayed.

### NOTE

- To cancel a selected destination, select the destination again to clear the check mark.
- If you select only one destination, press (Start) to send from the Address Book screen.
- [Access Number] is displayed on the screen only if Access Number Management in Restrict the Send Function in System Settings (from the Additional Functions screen) is set to 'On'. (See "Access Number Management," on p. 11-16.)



# Using the One-Touch Buttons

You can specify up to 200 destinations in one-touch buttons.

Follow this procedure to start a transmission and send a document with the press of a one-touch button.



## IMPORTANT

To use this feature, you must first register destinations in one-touch buttons by pressing  (Additional Functions) → [Address Book Settings] → [One-touch Buttons]. (See "Storing/Editing One-Touch Buttons," on p. 10-35.)

## 1 Press [One-touch].

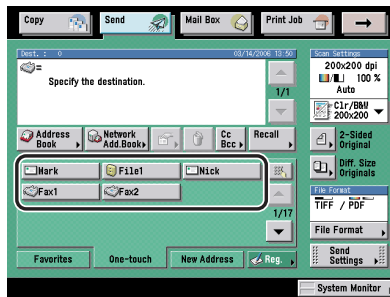
## 2 Select the desired one-touch button.



Each one-touch button is assigned a three digit number. If you know the one-touch button's three digit number, you can press  (One-Touch Button Number) → enter the three digit number of the desired one-touch button using  (numeric keys).

## NOTE

- You can select multiple one-touch buttons.
- To cancel the selected one-touch button, press the one-touch button again.

# Using the Favorites Buttons

If you frequently send documents with the same document settings to the same destination, store these settings in a favorites button. Then, when you need to specify the destination, all you have to do is select the favorites button containing your stored document settings and the desired destination, and send your document.

## IMPORTANT



To use this feature, you must first register the desired document settings and destinations in favorites buttons. (See "Favorites Buttons," on p. 9-16.)

**1** Press [Favorites].

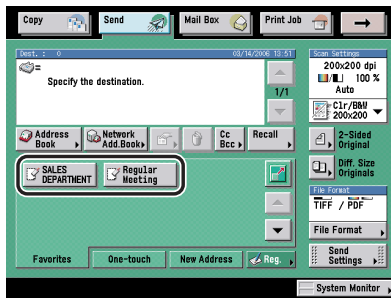
**2** Select the desired Favorites Button.



## NOTE

- You can manually change the recalled settings from the selected favorites button before you send your documents.
- If you press another favorites button, the settings stored in that button are recalled.
- To cancel all settings and return the machine to the Standard mode, press  (Reset).
- If multiple destinations are stored under the selected favorites button, the destinations may not be listed in the order in which they were set.
- You can enlarge the Favorites Buttons display by pressing . (See "Initial Send Screen Display," on p. 9-27.)

## Using a Server

You can specify a destination by searching the directory listings on the network using LDAP (Lightweight Directory Access Protocol) servers. LDAP servers are for looking up a particular piece of information, such as a user name, e-mail address, or other contact information.

### NOTE

- You may have to set up the LDAP servers beforehand, depending on the network environment.
- For more information on LDAP servers, see "Addresses Obtained via a Server," on p. 10-23.
- You can send to a maximum of 64 destinations at the same time, including destinations that are specified via a server.
- The information that can be obtained via the LDAP server consists of only names and e-mail addresses. If the optional Super G3 FAX Board or Super G3 Multi-Line Fax Board is installed, fax numbers, in addition to the above mentioned information, can be also obtained via the LDAP server.
- You cannot directly specify a destination that is obtained via a server as a forwarding destination. To specify the destination as a forwarding destination, you must first store it in the Address Book. (See "Addresses Obtained via a Server," on p. 10-23.)

**1** Press [Network Add.Book].

**2** Press the Server to Search drop-down list → select the desired server to search.

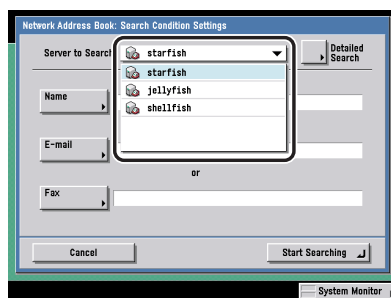

### 3 Specify the search criteria.

#### NOTE

If you want to search for a destination that is registered with an e-mail address and a fax number, you can search for the e-mail address by entering the fax number as the search criterion, and vice versa.

#### ● To use Simple Search:

- Press [Name], [E-mail], or [Fax] → enter the name, e-mail address, or fax number for which you want to search → press [OK].

The search criteria boxes that are not filled out, are not searched.

To make a more detailed search with multiple search conditions, press [Detailed Search], and follow the directions below. The search criteria you entered for Simple Search are continuously used in Detailed Search.

#### ● To use Detailed Search:

- Press [Detailed Search].
- Press the search category drop-down list → select the desired search category.

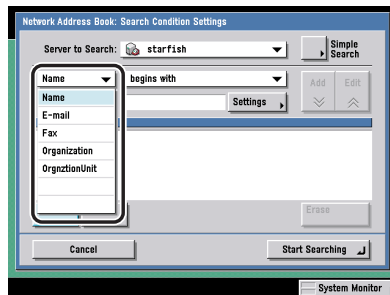

The available search categories are:

[Name]: Search by name.

[E-mail]: Search by e-mail address.

[Fax]: Search by fax number.

[Organization]: Search by organization name.

[OrgnztionUnit]: Search by organizational unit (e.g., departments in an organization).

For example, if cn(common name)=user1, ou(organization unit)=salesdept, o(organization)=canon, c(country)=jp is the distinguished name in the directory, enter the organization/organizationUnit of the user as follows:

organization=canon

organizationUnit=salesdept

 **NOTE**

- The organization/organizationUnit can be used as search categories only if the information has been registered on the LDAP Server.
- Detailed Search by organization/organizationUnit may not be performed, depending on whether the attribute types have been registered on the LDAP server, and depending on the type of application on the server.
- You can also add additional user-defined search attributes. For more information on registering or editing a search attribute, see "Registering/Editing LDAP Search Attributes," on p. 11-49.

- Press the search condition drop-down list → select the desired search condition → press [Settings].

You can select from the following search conditions:

- [contains]: The result must contain the entered name, e-mail address, fax number, organization, or organizational unit.
- [does not contain]: The result must not contain the entered name, e-mail address, fax number, organization, or organizational unit.
- [equals]: The result must be exactly the same as the entered name, e-mail address, fax number, organization, or organizational unit.
- [differs from]: The result must be different from the entered name, e-mail address, fax number, organization, or organizational unit.
- [begins with]: The result must begin with the same first few letters that you entered for the name, e-mail address, fax number, organization, or organizational unit.
- [ends with]: The result must end with the same last few letters that you entered for the name, e-mail address, fax number, organization, or organizational unit.

- Enter the search criterion → press [OK].

- Press [Add].

To continue adding more search criteria, press [or] or [and] → repeat step 3.

[or]: The machine searches and returns a result that matches any of the specified search criteria.

[and]: The machine searches and returns a result that matches all of the specified search criteria.

To edit the search criteria, select the search criterion that you want to edit → press [Edit] → [Settings].

To delete the search criteria, select the criterion that you want to erase → press [Erase].

**NOTE**

- You can specify up to four different search criteria at a time.
- If you specify three or more search criteria, you cannot use both [or] and [and] together.
- If you press [Simple Search] after specifying search criteria on the Detailed Search screen, the display changes to the Simple Search screen, and the specified detailed search criteria are deleted.

**4 Press [Start Searching].**

To cancel searching while the machine is searching for your criteria, press [Cancel]. If the machine finds some results before you press [Cancel], these search results are displayed.

**IMPORTANT**

- Searching for a destination via an LDAP server is not possible if the time setting of the server and the time setting of the machine are more than five minutes apart. If you cannot send even when the user name and password are correct, check the time settings on the server and the machine.
- The number of search results displayed will not exceed the maximum limit set in Register LDAP Server in System Settings (from the Additional Functions screen). If the desired destination is not displayed, either increase the maximum number of addresses to search, or change the search criteria. (See "LDAP Server Settings," on p. 11-43.)

**NOTE**

If you press [Start Searching] without specifying any search criteria, all of the addresses stored on the LDAP server are displayed.

**● If the Enter Network Password screen is displayed:**

- Specify each setting → press [OK].

The Enter Network Password screen is displayed if either one of the following is true:

- If <Login Information> in Register LDAP Server in System Settings (from the Additional Functions screen) is set to 'Use', and <Display authentication dialog when searching> is set to 'On'.
- If the user name, password, and domain name specified in Register LDAP Server in System Settings (from the Additional Functions screen) are incorrect.

[User]:

Press [User] → enter the user name → press [OK].

[Password]:

Press [Password] → enter the password → press [OK].

After pressing [OK], the password that you entered appears as asterisks (\*\*\*\*\*) on the Enter Network Password screen.

## 5 Select the desired destination from the search results → press [OK].

To continue searching, press [Back].

You can specify multiple destinations.

E-mail addresses that meet the specified search criteria are displayed. If you press [Select e-mail for I-Fax], the key lights, showing that this setting is turned on, and the selected e-mail address can be specified as an I-fax destination.

If the optional Super G3 FAX Board or Super G3 Multi-Line Fax Board is installed, fax numbers that meet the specified search criteria are displayed.

If the optional Super G3 FAX Board or Super G3 Multi-Line Fax Board is installed, you can sort and limit the view of the displayed addresses by using the Type drop-down list.



### NOTE

- To cancel a selected destination, select the destination again to clear the check mark.
- If you specify an e-mail address as an I-fax destination, the only information that can be retrieved from the server is the I-fax address. To specify settings to match the recipient's receiving conditions, press [Details] on the Send screen.
- If you select only one destination, press  (Start) to send from the Search Results screen.

## 6 If a fax number or I-fax address is specified as the destination, read the displayed message → press [OK].

# Setting Cc and Bcc Addresses

In addition to the destination for the documents, you can also set multiple e-mail address destinations for the Cc (Carbon copy) and Bcc (Blind carbon copy) addresses.

## NOTE

- Only e-mail addresses can be specified for [Cc] and [Bcc].
- A maximum of 64 destinations can be specified for [Cc] and [Bcc], including those obtained using New Address Tab or via a server (User Inboxes are not included in this count). Group Addresses cannot be specified for [Cc] and [Bcc].

## 1 Press [Cc Bcc].

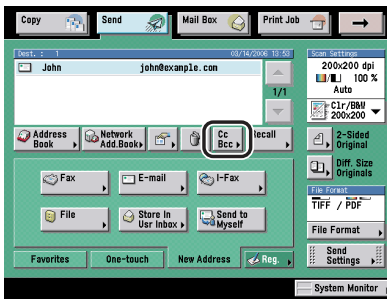



## 2 Specify the e-mail addresses → press [Done].

Follow the procedure below to set the e-mail addresses for [Cc] and [Bcc].

- For instructions on specifying destinations not registered in the Address Book, see "Specifying Destinations Using the New Address Tab," on p. 2-2.
- For instructions on specifying destinations stored in the Address Book, see "Using the Address Book," on p. 2-23.
- For instructions on specifying destinations using the one-touch buttons, see "Using the One-Touch Buttons," on p. 2-25.
- For instructions on specifying destinations and settings using the favorites buttons, see "Using the Favorites Buttons," on p. 2-26.
- For instructions on specifying a destination by searching through the directory listings on a server on the network using LDAP (Lightweight Directory Access Protocol), see "Using a Server," on p. 2-27.

### ● To specify e-mail addresses for [Cc]:

- Press [Cc] → specify the e-mail addresses.

### ● To specify e-mail addresses for [Bcc]:

- Press [Bcc] → specify the e-mail addresses.

### ● To move e-mail addresses from [To] or [Bcc] to [Cc]:

- Press [From To/Bcc].
- Press [To] or [Bcc] → select the desired e-mail addresses → press [OK].



#### NOTE

[From To/Bcc] is displayed only if you pressed [Cc].

### ● To move e-mail addresses from [To] or [Cc] to [Bcc]:

- Press [From To/Cc].
- Press [To] or [Cc] → select the desired e-mail addresses → press [OK].



#### NOTE

[From To/Cc] is displayed only if you pressed [Bcc].

# Checking/Changing a Destination

You can check and change a specified destination before you scan your documents.

## NOTE

- Only the destinations specified using the New Address tab and destinations obtained via a server can be changed.
- For instructions on changing the specified destination after you scan your document, see "Changing the Destination," on p. 8-5.
- You cannot change multiple destinations simultaneously.

## 1 Select the destination → press [Details].

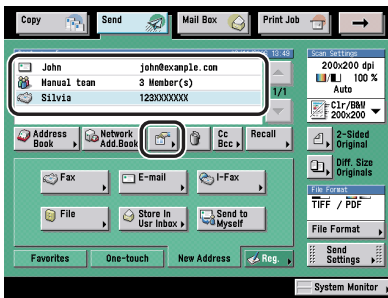

## 2 If necessary, check or change the destination's information.

- **If the destination has been specified from the Address Book:**
  - Check the destination's information → press [Done].
- **If the destination has been specified using one of the sending methods in the New Address tab:**
  - Check or change the destination's information → press [OK].

Change the destination's information in the same way that you specified it. (See "Specifying Destinations Using the New Address Tab," on p. 2-2.)

● **If the destination is obtained via a server:**

- Check or change the destination's information → press [OK].

Change the destination's information in the same way that you specified it.  
(See "Specifying Destinations Using the New Address Tab," on p. 2-2.)

● **If the destination is a group address:**

- To check the information of registered destinations in a group address, select one destination at a time → press [Details].
- Check the destination's information → press [Done] → [Done].

# Erasing a Destination

You can erase a specified destination from the destination list before you scan your documents.

- 1 Select the destination to be erased → press [Erase].

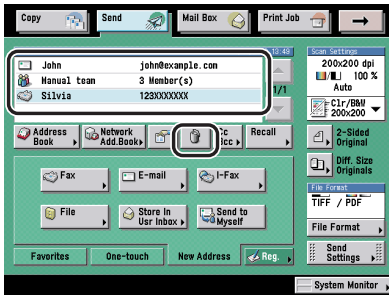

# Registering New Destinations Using the Register Key

You can register new destinations in the Address Book, one-touch buttons, and favorites buttons from the Send Basic Features and the Address Book screens.

The Register key is a shortcut key to the Register Address screen in Address Book Settings (from the Additional Functions screen), the One-touch Buttons screen in Address Book Settings (from the Additional Functions screen), and the Register Favorites Button screen in TX Settings under <Common Settings> in Communications Settings (from the Additional Functions screen).

2

Basic Sending Methods

- 1 Press [Reg.].
- 2 Select the item you want to register.

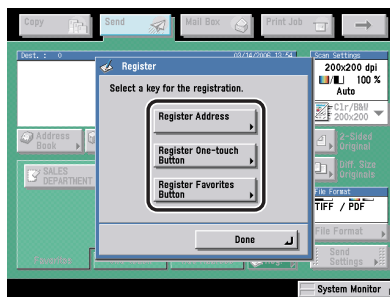

## ● To register a destination in the Address Book:

- Press [Register Address] → register the destination.

For instructions on registering destinations, see Chapter 10, "Storing/Editing Address Book Settings."

## ● To register a destination in a one-touch button:

- Press [Register One-touch Button] → register the destination in a one-touch button.

For instructions on registering addresses in a one-touch button, see "Storing/Editing One-Touch Buttons," on p. 10-35.

● **To register destinations and settings in a favorites button:**

- Press [Register Favorites Button] → register destinations and settings in a favorites button.

For instructions on registering destinations and settings in a favorites button, see "Registering a Favorites Button," on p. 9-16.

You can also register a destination in the Address Book or a one-touch button by pressing [Address Book] → [Register].

# 3

## CHAPTER

# Basic Scanning Features

This chapter describes the basic scanning features.

---

Selecting a Scan Mode . . . . .	3-2
Scan Settings . . . . .	3-4
2-Sided Original . . . . .	3-4
Different Size Originals . . . . .	3-6
Document Size . . . . .	3-8
Resolution . . . . .	3-12
Scan Exposure and Original Type Settings . . . . .	3-13
Changing the Zoom Ratio . . . . .	3-17
Changing Color Modes . . . . .	3-21

## Selecting a Scan Mode

You can set the scan mode in which a document is scanned. The machine has eight preset scan modes: Clr/B&W 200 x 200 dpi, Clr/B&W 300 x 300 dpi, B&W 200 x 200 dpi, B&W 300 x 300 dpi, Clr/Gray 200 x 200 dpi, Clr/Gray 300 x 300 dpi, Clr/Gray 600 x 600 dpi, and B&W 600 x 600 dpi.

Select the desired mode from the preset scan modes or user defined scan modes (user preset keys), according to the type of original that you are sending.

### NOTE

- If you want to use less memory and make the sending time shorter, use a lower resolution mode.
- You can adjust the preset scan modes and create new scan settings. However, since changed scan settings are not automatically saved, it is useful to register a new scan setting if you use it frequently. (See "User Preset Keys," on p. 4-17.)
- You can change the settings and assigned names for the eight preset scan keys, and store them as user defined scan modes (user preset keys).
- In addition to the scan mode, you can store addresses and other send settings in the favorites buttons. (See "Favorites Buttons," on p. 9-16.)
- To cancel the scan settings, press the Scan Settings drop-down list → press [Option] → [Cancel].
- If [Preview] on the Send Settings screen is set, you can verify the images from the Preview screen before sending your document. (See "Previewing Originals," on p. 5-17.)
- To cancel all settings and return the machine to the Standard mode, press  (Reset).

## 1 Place your originals → specify the destination → press the Scan Settings drop-down list → select the scan mode.

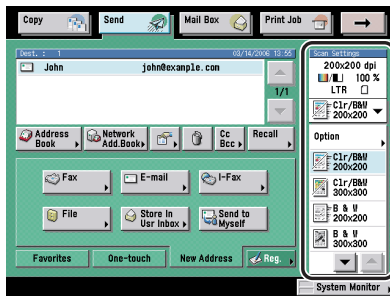



For more information on specifying the destination, see Chapter 2, "Basic Sending Methods."



#### NOTE

- Specifying the scan mode again cancels the scan mode and other scan features previously set.
- You can also select a scan mode by pressing [Option] from the Scan Settings drop-down list to display the Scan Settings screen → press the Scanning Mode drop-down list → select a scan mode.

## 2 Press (Start).

If [PDF (Trace)] or [PDF (Compact)] is selected as the file format, select a scan mode from the Scanning Mode drop-down list whose Color Selection mode and resolution have been registered as one of the following combinations. If you select a combination other than those listed below, a message asking for your confirmation to change the file format appears on the screen.

- Auto-Color Select (Full Color/Grayscale) and 300 x 300 dpi
- Full Color and 300 x 300 dpi
- Grayscale and 300 x 300 dpi



#### NOTE

You can store the changed settings. (See "User Preset Keys," on p. 4-17.)

# Scan Settings

## NOTE

- Changed scan settings are not saved. For instructions on saving settings, see "User Preset Keys," on p. 4-17.
- If [Preview] on the Send Settings screen is set, you can verify the images from the Preview screen before sending your document. (See "Previewing Originals," on p. 5-17.)
- To cancel all settings and return the machine to the Standard mode, press  (Reset).

## 2-Sided Original

You can set the machine to automatically turn over two-sided originals that are placed in the feeder, and scan each side separately.

## IMPORTANT

- The 2-Sided Original mode is available only if the optional Feeder (DADF-L1) (standard-equipped for Color imageRUNNER C3380i/C2880i) is attached.
- The 2-Sided Original mode cannot be used with the Document Size Select (Other Size, Long Strip Original) or 2-Page Separation mode.
- The 2-Sided Original mode cannot be used when sending a fax document in the Direct Sending or Manual Sending mode.
- When you are scanning originals with a horizontal (landscape) orientation, such as LTRR, make sure to place them horizontally into the feeder. If these originals are placed vertically, the back sides of these originals are scanned upside down.

## NOTE

To cancel this setting, press [2-Sided Original] → [Cancel].

**1 Place your originals into the feeder → specify the destination → press [2-Sided Original].**

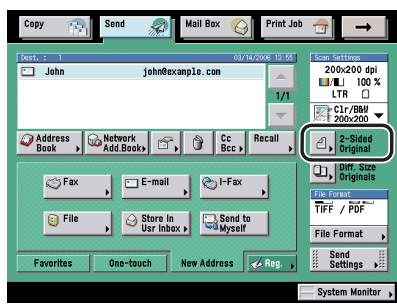

For more information on specifying the destination, see Chapter 2, "Basic Sending Methods."

**2 Select the type of original → press [OK].**

Details of each item are shown below.

[Book Type]: The front and back sides of the original have the same top-bottom orientation.

[Calendar Type]: The front and back sides of the original have opposite top-bottom orientations.

**3 Press  (Start).**

## Different Size Originals

This mode enables you to copy (scan) different size originals with the same widths (11" x 17" and LTR, or LTRR and STMT) or different widths (11" x 17" and STMT, or LTR and LGL), together as one group by setting them in the feeder.

### IMPORTANT

- The Different Size Originals mode cannot be used with the Document Size Select (Other Size or Long Strip Original), 2-Page Separation, Original Frame Erase, or Book Frame Erase mode.
- The Different Size Originals mode cannot be used when sending a fax document in the Direct Sending or Manual Sending mode.
- If Document Size Select setting is set to anything other than [Auto], all of the originals are scanned in the specified size. If you want to scan the originals in their original sizes, make sure to set Document Size Select to [Auto].
- If the originals are placed in the feeder, make sure that the different size originals are of the same weight (paper type).
- Align the top edge of the originals with the back edge of the feeder if you are placing originals with different widths. ("Width" refers to the vertical measurement of the paper from the front of the machine to the back of the machine when the paper is placed in the feeder or on the platen glass.)
- If you send different sized originals via fax, the paper size used to output the faxes on the recipient's machine is the size of the largest document you sent. For example, if you send an LTR and 11" x 17" original via fax, they will both be output on 11" x 17" paper at the recipient's machine.
- If the originals are placed in the feeder, set differently size originals in the following combinations. Other combinations may damage the originals.
  - 11" x 17" and LGL, LTR and LGL, LTR and LTRR
- If you place originals with different widths into the feeder, the originals may move slightly when fed to the platen glass. As a result, the images may be scanned and copied as slanted.
- If the Different Size Originals mode is set, the scanning speed may be slower than normal.

### NOTE

To cancel this setting, press [Different Size Originals] → [Cancel].

**1 Place your originals → specify the destination → press [Different Size Originals].**

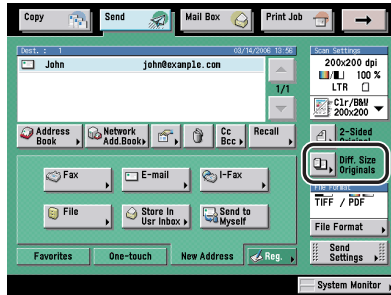

For more information on specifying the destination, see Chapter 2, "Basic Sending Methods."

**2 Select the type of originals → press [OK].**

Details of each item are shown below.

[Same Width]: Press this key if you are placing originals with the same width.

[Different Width]: Press this key if you are placing originals with different widths.

**3 Press  (Start).**

# Document Size

You can manually specify the document size when the machine cannot detect the paper size automatically, such as when scanning transparencies. Specify the document size as well, if you want to scan an 11" x 17" original with an image that extends all the way to the edges without the periphery of the original being cut off. You can also store the specified document size.



## IMPORTANT

- You cannot select [Auto] when scanning the following types of originals. Specify the size of these documents manually.
  - Nonstandard size originals
  - Highly transparent originals, such as transparencies
  - Originals with an extremely dark background
  - STMT, STMTR, or smaller originals that are placed on the platen glass (STMT originals must be placed only into the feeder, as they cannot be automatically detected when placed on the platen glass.)
- If you are sending a fax in the Direct Sending or Manual Sending mode, and you place your originals into the feeder, the Document Size Select setting that you specify will be disabled.
- If the original is placed in the feeder, you cannot scan by selecting [Other Size] in Document Size Select.
- If you select [Long Strip Original], place your originals into the feeder. You cannot specify the size of a long strip original that is placed on the platen glass.
- If [Long Strip Original] is selected as the document size, documents can be sent only at a zoom ratio of 100%.
- If you select [Other Size] in Document Size Select, you cannot select [Stamp].



## NOTE

- If you scan a registered document size, the scanned image is not rotated automatically.
- To cancel the scan settings, press the Scan Settings drop-down list → press [Option] → [Cancel].

## *Specifying the Document Size*

### **1 Place your originals and specify the destination → press the Scan Settings drop-down list → press [Option].**

For more information on specifying the destination, see Chapter 2, "Basic Sending Methods."

## 2 Press [Document Size Select].

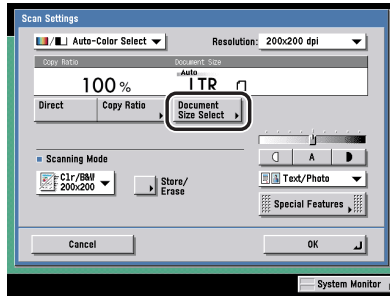

## 3 Select the document size.

- If you want to scan a standard document size:
  - Select the desired document size.

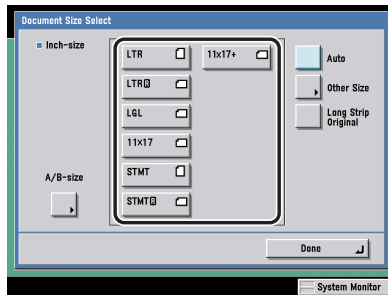

If you want to scan an 11" x 17" original with an image that extends all the way to the edges without the periphery of the original being cut off, place the original on the platen glass → press [11x17+]. (See Chapter 2, "Basic Operations," in the *Reference Guide*.)

 **NOTE**

- To select an A or B series paper size, press [A/B-size].
- If you want to scan originals longer than the standard sizes, press [Long Strip Originals]. The length of standard size originals is as follows:
  - LTR: 11" (279.4 mm)
  - 11" x 17": 17" (431.8 mm)

● **If you want to scan a nonstandard document size:**

- Press [Other Size].
- Press [X] (horizontal axis) → enter a value.
- Press [Y] (vertical axis) → enter a value.
- Press [OK].

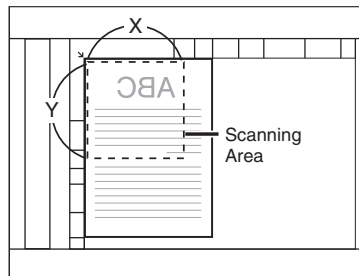
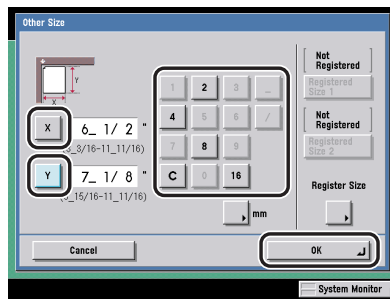

The Platen Glass

 **NOTE**

For instructions on entering values in inches, see Chapter 2, "Basic Operations," in the Reference Guide.

● **If you want to scan a registered document size:**

- Press [Other Size].
- Press [Registered Size 1] or [Registered Size 2] → press [OK].



 **NOTE**

- To select a registered document size, you need to register the document size beforehand. (See "Registering the Specified Document Size," on p. 3-11.)
- The registered document size is displayed on top of the key in which it is registered.

**4** Press [Done] → [OK].

**5** Press  (Start).

## Registering the Specified Document Size

**1** Press the Scan Settings drop-down list → press [Option] → [Document Size Select].

If necessary, see the screen shots in step 1 and step 2 of "Specifying the Document Size," on p. 3-8.

**2** Press [Other Size].

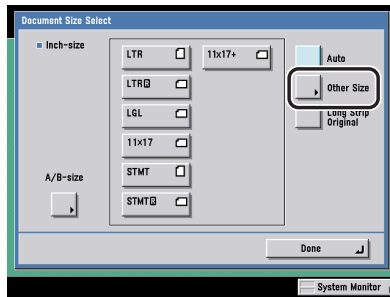

**3** Press [Register Size].

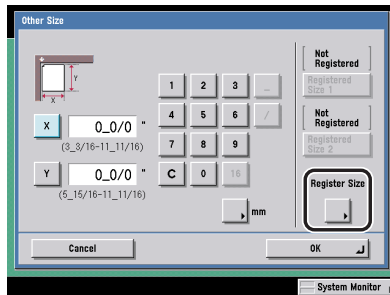

## 4 Press [Registered Size 1] or [Registered Size 2] → enter the document size using the numeric keys on the touch panel display.

- Press [X] (horizontal axis) → enter a value.
- Press [Y] (vertical axis) → enter a value.
- Press [OK].



### NOTE

- If you register a new document size in a key that already has a document size stored in it, the new document size overwrites the previously registered document size.
- For instructions on entering values in inches, see Chapter 2, "Basic Operations," in the *Reference Guide*.

## 5 Press [Cancel] → [Done] → [Cancel].

## Resolution

You can specify the resolution before scanning the original.



### IMPORTANT

- The maximum size of an image that you can send at 600 x 600 dpi resolution is 11" x 17". If the image exceeds this size, it may be cut off.
- If the optional Super G3 FAX Board or Super G3 Multi-Line Fax Board is installed and you are sending documents by fax, the maximum size of an image that you can send at 400 x 400 dpi resolution is 11" x 17".
- If you are sending documents by fax, select Black 200 x 100 dpi, Black 200 x 200 dpi, Black 200 x 400 dpi, or Black 400 x 400 dpi. Otherwise, the document will be sent with poor resolution.
- If you send a long strip original at 600 x 600 dpi, the periphery of the original image may be cut off slightly.



### NOTE

To cancel the scan settings, press the Scan Settings drop-down list → press [Option] → [Cancel].

## 1 Place your originals → specify the destination → press the Scan Settings drop-down list → press [Option].

For more information on specifying the destination, see Chapter 2, "Basic Sending Methods."

- 2 Press the Resolution drop-down list → select a resolution → press [OK].

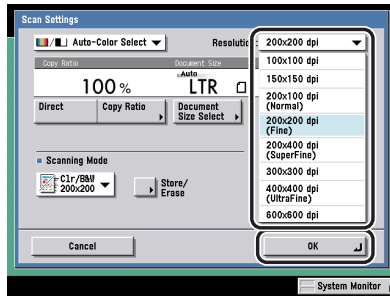

If [PDF (Trace)] or [PDF (Compact)] is selected as the file format, and you select any resolution other than [300x300 dpi], and then press [OK], a message asking for your confirmation to change the PDF file format appears on the screen.

- 3 Press  (Start).

## Scan Exposure and Original Type Settings

### NOTE

To cancel the scan settings, press the Scan Settings drop-down list → press [Option] → [Cancel].

### *Manual Exposure Adjustment*

You can manually adjust the scan exposure to the most appropriate level for the original.

- 1 Place your originals → specify the destination → press the Scan Settings drop-down list → press [Option].

For more information on specifying the destination, see Chapter 2, "Basic Sending Methods."

## 2 Press [◀] or [▶] to adjust the scan exposure → press [OK].

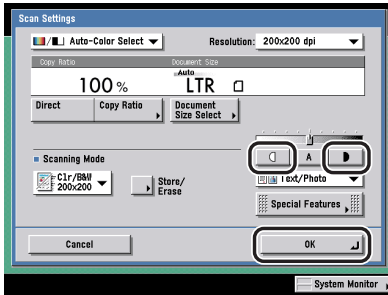

Press [◀] to move the indicator to the left to make the exposure lighter, or press [▶] to move it to the right to make the exposure darker.

## 3 Press (Start).

### *Original Type Selection*

You can manually select the original type according to the type of image that you are scanning. The following three original type modes are available for adjusting the image quality.



#### IMPORTANT

- Combinations of these three modes (Text/Photo, Photo, and Text) cannot be selected at the same time. If you select one of these modes, the previously set mode is canceled.
- If you scan an original containing halftones, such as a printed image, using the Photo mode, the moiré effect (a shimmering, wavy pattern) may occur. In this case, you can lessen this moiré effect by using the Sharpness mode. (See "Adjusting the Contrast (Sharpness)," on p. 4-13.)



#### NOTE

- If you select the Text, Text/Photo, or Photo mode, the scanning exposure can only be adjusted manually. Automatic exposure adjustment cannot be set.
- If the original is a transparency, select the original type → adjust the exposure to the most appropriate level for the original.

#### ■ Text/Photo Mode

This mode is best suited for scanning originals containing both text and photos, such as magazines or catalogues.

#### ■ Photo Mode

This mode is best suited for scanning photos printed on photographic paper, or photo originals containing halftones (e.g., printed photos).

## ■ Text Mode

This mode is best suited for scanning text originals. Blueprints or pencil drawn originals can also be scanned clearly. When [PDF (Compact)] is selected as the file format, if the Text mode is selected, the Image Level in Text Mode setting made in Image Level for PDF (Compact) in TX Settings under <Common Settings> in Communications Settings (from the Additional Functions screen) is activated. (See "PDF Compression Priority," on p. 9-21.)

### 1 Place your originals → specify the destination → press the Scan Settings drop-down list → press [Option].

For more information on specifying the destination, see Chapter 2, "Basic Sending Methods."

### 2 Press the original type drop-down list → select the original type ([Text/Photo], [Photo], or [Text]).

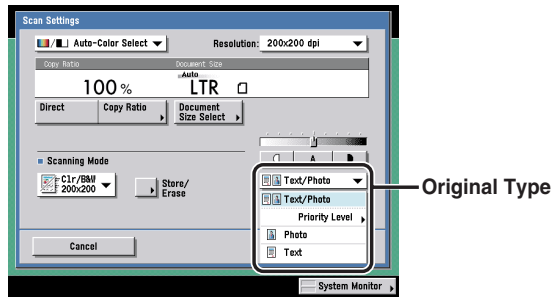

#### ● If you want to adjust the text/photo processing priority level:

- Press the original type drop-down list → press [Priority Level].
- Press [Text Priority] or [Photo Priority] to adjust the degree of priority for text or photo images → press [OK].

<Priority Level>:

[Text Priority]: Priority is given to the faithful reproduction of text.

[Photo Priority]: Priority is given to the faithful reproduction of photos, with as little moiré effect as possible.

### 3 Press [◀] or [▶] to adjust the scanning exposure → [OK].

Press [◀] to move the indicator to the left to make the exposure light, or press [▶] to move the indicator to the right to make the exposure darker.

## 4 Press (Start).

### *Automatic Exposure Adjustment*

This mode enables you to set the machine to automatically adjust the scan exposure to the level best suited to the quality of the original.

#### IMPORTANT

When using Direct Sending or Manual Sending mode for sending a fax, the automatic scan adjustment mode cannot be used.

#### NOTE

There are two types of automatic scan exposure adjustments. The Remove Background mode enables you to scan by erasing the background color of the original, and the Prevent Bleeding mode enables you to prevent the original image on the reverse side of the original from appearing on the scanned pages. Select the desired scan exposure adjustment mode depending on the type of original. The Remove Background mode is selected by default. (See "Image Quality Adjustment," on p. 4-14.)



## 1 Place your originals → specify the destination → press the Scan Settings drop-down list → press [Option].

For more information on specifying the destination, see Chapter 2, "Basic Sending Methods."

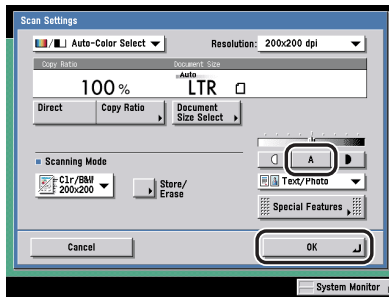
## 2 Press [A] → [OK].



#### NOTE

An automatic scan exposure adjustment may not work with transparencies. In this case, adjust the scan exposure manually by pressing [] or [].

## 3 Press (Start).

## Changing the Zoom Ratio

You can set the machine to adjust the zoom ratio automatically, or you can specify the zoom ratio manually before scanning the original.



### IMPORTANT

- The maximum size of an image that you can send at 600 x 600 dpi resolution is 11" x 17". If the image exceeds this size, it may be cut off.
- If you set [PDF (Trace)] or [PDF (Compact)] is selected as the file format, documents can be sent only at a zoom ratio of 100%.
- If [Long Strip Original] is selected as the document size, documents can be sent only at a zoom ratio of 100%.



### NOTE

To cancel the scan settings, press [Cancel] on the Scan Settings screen.

## Preset Zoom

The machine offers you a variety of preset zoom ratios to reduce or enlarge standard size originals to another standard record size.

### ■ Reduction

The available preset reduction zoom ratios are:

LGL → LTR (78%)

11" x 17" → LGL or 11" x 15" → LTR (73%)

11" x 17" → LTR (64%)

11" x 17" → STMT (50%)

### ■ Enlargement

The available preset enlargement zoom ratios are:

STMT → 11" x 17" (200%)

LTR → 11" x 17" (129%)

LGL → 11" x 17" (121%)

---

## 1 Place your originals and specify the destination → press the Scan Settings drop-down list → press [Option].

For more information on specifying the destination, see Chapter 2, "Basic Sending Methods."

## 2 Press [Copy Ratio].

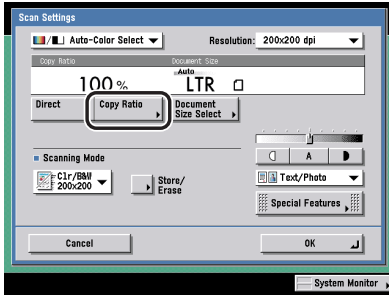

## 3 To reduce the original image, select a preset reduction ratio. To enlarge the original image, select a preset enlargement ratio. Following your selection, press [Done] → [OK].

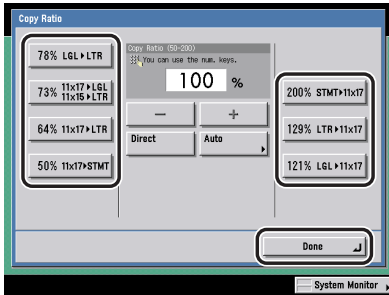

## 4 Press (Start).



### NOTE

To return the ratio to 100%, press [Direct].



## Zoom by Percentage

You can reduce or enlarge originals by any zoom ratio in 1% increments. Any ratio from 50% to 200% can be set. The same zoom ratio is used for the horizontal (X) and vertical (Y) axes.

### 1 Place your originals and specify the destination → press the Scan Settings drop-down list → press [Option] → [Copy Ratio].

If necessary, see the screen shots in step 1 and step 2 of "Preset Zoom," on p. 3-17.

For more information on specifying the destination, see Chapter 2, "Basic Sending Methods."

### 2 Press [-] or [+] to set a zoom ratio → press [Done] → [OK].

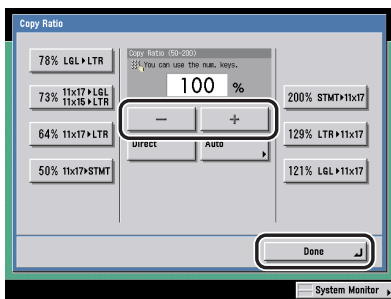

### 3 Press (Start).



#### NOTE

To return the ratio to 100%, press [Direct].

## Auto Zoom

You can set the machine to automatically select the appropriate zoom ratio based on the size of the original and the selected record size. The same zoom ratio is used for the horizontal (X) and vertical (Y) axes. Any zoom ratio from 50% to 200% can be set.



#### IMPORTANT

- You can only select the Auto setting on the Copy Ratio screen when the resolution is set to 300 x 300 dpi or 600 x 600 dpi.
- When using Direct Sending or Manual Sending mode for sending a fax, you cannot select the Auto setting on the Copy Ratio screen.

---

**1 Place your originals and specify the destination → press the Scan Settings drop-down list → press [Option] → [Copy Ratio].**

If necessary, see the screen shots in step 1 and step 2 of "Preset Zoom," on p. 3-17.

For more information on specifying the destination, see Chapter 2, "Basic Sending Methods."

**2 Press [Auto] → select the record size → press [OK].**

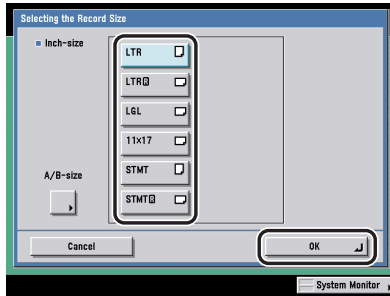

**3 Press [OK].**

**4 Press  (Start).**



**NOTE**

To return the ratio to 100%, press [Direct].

# Changing Color Modes

This machine comes with two Automatic Color Selection modes. Automatic Color Selection (Full Color/Grayscale) detects and distinguishes color originals from grayscale originals, while Automatic Color Selection (Full Color/Black-and-White) detects and distinguishes color originals from black-and-white originals. Depending on the Automatic Color Selection mode that you select, the machine automatically switches between the Full Color and Grayscale modes, or between the Full Color and Black-and-White modes. You can also manually select the Full Color, Grayscale, or Black-and-White mode whenever necessary.



## IMPORTANT

If the destination is a fax number, the original is always scanned and sent in the Black-and-White mode.



## NOTE

- The default setting is 'Auto-Color Select (Full Color/Black and White)'.
- To cancel the scan settings, press the Scan Settings drop-down list → press [Option] → [Cancel].
- If [Preview] on the Send Settings screen is set, you can verify the images from the Preview screen before sending your document. (See "Previewing Originals," on p. 5-17.)
- To cancel all settings and return the machine to the Standard mode, press  (Reset).

## ■ Automatic Color Selection (Full Color/Grayscale)

If the Automatic Color Selection (Full Color/Grayscale) mode is selected, the machine automatically recognizes whether the original is in color or black-and-white. Color originals are scanned in the Full Color mode, while black-and-white originals are scanned in the Grayscale mode.



## IMPORTANT

When the Auto-Color Select mode is set and your originals contain color sections, the machine scans them in the Full Color mode. However, the machine may scan the color originals in the Grayscale mode under the following conditions. To avoid this, set the color mode to 'Full Color'. (See "Full Color," on p. 3-22.)

- If the originals contain a few color sections
- If the color sections are located only on the left side (within 3/8" (10 mm) from the left edge) of the originals when placing the originals into the feeder
- If the originals contain light color densities
- If the color sections of the original are close to black

### ■ Automatic Color Selection (Full Color/Black-and-White)

If the Automatic Color Selection (Full Color/Black-and-White) mode is selected, the machine automatically recognizes whether the original is in color or black-and-white. Color originals are scanned in the Full Color mode, while black-and-white originals are scanned in the Black-and-White mode.

#### IMPORTANT

When the Auto-Color Select mode is set and your originals contain color sections, the machine scans them in the Full Color mode. However, the machine may scan the color originals in the Black-and-White mode under the following conditions. To avoid this, set the color mode to 'Full Color'. (See "Full Color," on p. 3-22.)

- If the originals contain a few color sections
- If the color sections are located only on the left side (within 3/8" (10 mm) from the left edge) of the originals when placing the originals into the feeder
- If the originals contain light color densities
- If the color sections of the original are close to black

### ■ Full Color

The Full Color mode always scans in color regardless of whether the original is in color or black-and-white. If either of the Automatic Color Selection modes is selected, originals that contain few color sections, or originals with light color densities and colors close to black may be scanned in the Grayscale or Black-and-White mode. If this happens, select the Full Color mode manually.

#### NOTE

If a black-and-white original is scanned in the Full Color mode, it is counted as a color scan.

### ■ Grayscale

The Grayscale mode always scans in grayscale regardless of whether the original is in color or black-and-white.

### ■ Black-and-White

The Black-and-White mode always scans in black-and-white regardless of whether the original is in color or black-and-white.

---

## 1 Place your originals → specify the destination → press the Scan Settings drop-down list → press [Option].

For more information on specifying the destination, see Chapter 2, "Basic Sending Methods."

- 2** Press the color selection drop-down list → press [Auto-Color Select (Full Color/Grayscale)], [Auto-Color Select (Full Color/Black-and-White)], [Full Color], [Grayscale], or [Black and White] → [OK].

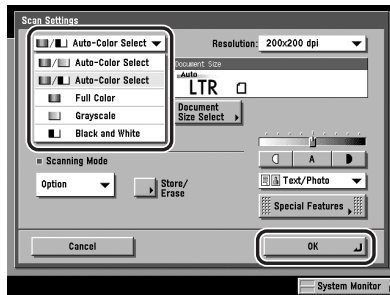

When [PDF (Trace)] or [PDF (Compact)] is selected as the file format, if you specify [Auto-Color Select (Full Color/Black-and-White)] or [Black and White] as the color mode and press [OK], a message asking for your confirmation to change the file format appears on the screen.

**IMPORTANT**

- If [PDF (Trace)] or [PDF (Compact)] is selected as the file format, the color mode is automatically changed to [Auto-Color Select (Full Color/Grayscale)] even if you set the color mode to [Auto-Color Select (Full Color/Black-and-White)]. If you want to send the document in the Automatic Color Selection (Full Color/Black-and-White) mode, change the file format to anything other than [PDF (Trace)] or [PDF (Compact)].
- If [PDF (Trace)] or [PDF (Compact)] is selected as the file format, the color mode is automatically changed to [Grayscale] even if you set the color mode to [Black and White]. If you want to send the document in the Black-and-White mode, change the file format setting to anything other than [PDF (Trace)] or [PDF (Compact)].

- 3** Press  (Start).



# 4

## CHAPTER

# Special Scanning Features

This chapter describes the special scanning features.

---

What are Special Features? . . . . .	4-2
2-Page Separation . . . . .	4-4
Frame Erase . . . . .	4-5
Original Frame Erase . . . . .	4-6
Book Frame Erase . . . . .	4-7
Binding Erase . . . . .	4-9
Job Build . . . . .	4-10
Adjusting the Contrast (Sharpness) . . . . .	4-13
Image Quality Adjustment. . . . .	4-14
Remove Background . . . . .	4-14
Prevent Bleeding . . . . .	4-16
User Preset Keys . . . . .	4-17
Storing Scan Settings. . . . .	4-17
Naming a User Preset Key. . . . .	4-19
Erasing Scan Settings . . . . .	4-20

# What are Special Features?

Special features, such as the Frame Erase and Job Build modes, are modes for performing various kinds of editing according to your needs, when sending a document.

## IMPORTANT

Depending on the mode, some combinations of modes will not be available. See the corresponding section on each mode for detailed information.

### 1 Place your original on the platen glass → specify the destination.

For more information on specifying the destination, see Chapter 2, "Basic Sending Methods."

### 2 Press the Scan Settings drop-down list → press [Option].

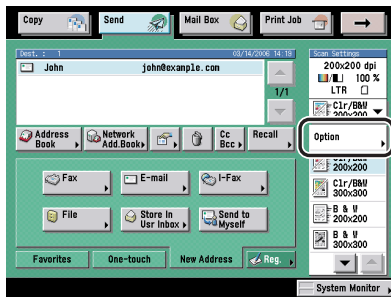

### 3 Press [Special Features].

## IMPORTANT

Depending on the mode, you may have to place your original on the platen glass or in the feeder. See the corresponding section on each mode for detailed information.



## 4 Select the desired mode from the Special Features screen.

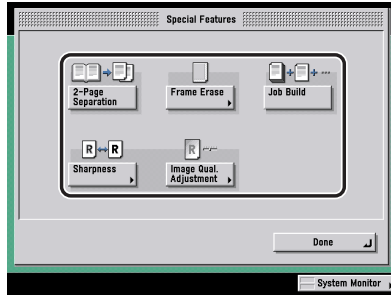

## 5 Set the desired mode.

For more information on setting each mode, see the corresponding section.  
To set other modes at the same time, repeat steps 4 and 5.

## 6 Press (Start).

If the original is placed on the platen glass, follow the instructions that appear on the touch panel display → press  (Start) once for each original. When scanning is complete, press [Done].

Scanning starts.

The scanned data is sent to the specified destination when scanning is complete.

### NOTE

- To cancel this setting, follow the procedure below.
  - For modes which have a right triangle (▶) on the bottom right of their key:  
Example: Frame Erase  
Press [Special Features] → [Frame Erase] → [Cancel].
  - For modes which do not have a right triangle (▶) on the bottom right of their key:  
Example: Job Build  
Press [Special Features] → [Job Build].
- To cancel the scan settings, press the Scan Settings drop-down list → press [Option] → [Cancel].
- If [Preview] on the Send Settings screen is set, you can verify the images from the Preview screen before sending your document. (See "Previewing Originals," on p. 5-17.)
- To cancel all settings and return the machine to the Standard mode, press  (Reset).

# 2-Page Separation

This mode enables you to scan facing pages in a book or bound original and record them onto separate pages.

## IMPORTANT

- The 2-Page Separation mode cannot be used with the Document Size Select (11x17+, Other Size, and Long Strip Original), 2-Sided Original, Different Size Originals, or Binding Erase mode.
- The 2-Page Separation mode cannot be used when sending a fax document in the Direct Sending or Manual Sending mode.
- Place your original on the platen glass. The 2-Page Separation mode cannot be used when the original is placed in the feeder.

## **1** Place your originals and specify the destination → press the **Scan Settings drop-down list** → **[Option]** → **[Special Features]** → **[2-Page Separation]**.

For more information on specifying the destination, see Chapter 2, "Basic Sending Methods."

# Frame Erase

---

This mode enables you to erase shadows and lines that appear when scanning various types of originals.

The following three Frame Erase modes are available.



## IMPORTANT

- Combinations of the three Frame Erase modes cannot be set. If you select one of these modes, the previously set mode is canceled.
- The Frame Erase mode cannot be used when sending a fax document in the Direct Sending or Manual Sending mode.

### ■ Original Frame Erase

This mode erases the dark borders and frame lines that appear around the scanned image if the original is smaller than the selected record size. You can also use this mode to create a blank border around the edge of the scanned image.

### ■ Book Frame Erase

This mode erases the dark borders, as well as center and contour lines that appear if you are scanning facing pages in a book or bound original.

### ■ Binding Erase

This mode erases the shadows that appear on the scanned image from binding holes on originals.

# Original Frame Erase

## IMPORTANT

The Original Frame Erase mode cannot be used with the Document Size Select (11x17+, Auto, Other Size, and Long Strip Original) or Different Size Originals mode.

- 1 Place your originals and specify the destination → press the Scan Settings drop-down list → [Option] → [Special Features] → [Frame Erase].**

For more information on specifying the destination, see Chapter 2, "Basic Sending Methods."

- 2 Press [Original Frame Erase].**

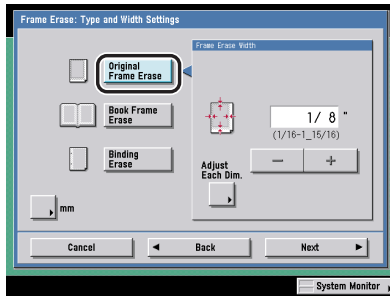

- 3 Press [-] or [+] to set the frame erase width.**

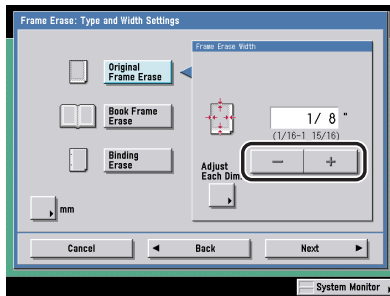

- **If you want to set the same width for all four borders:**

Press [-] or [+] to set the frame erase width → press [Next].

● **If you want to set the top, left, right, and bottom widths independently:**

- Press [Adjust Each Dim.].
- Select the desired frame erase borders → press [-] or [+] to set their respective frame erase widths → press [Next].  
To return to the screen for setting the same width for all four borders, press [Adjust All At Once].

**4 Select the original size → press [OK].**



**IMPORTANT**

You can set the Original Frame Erase mode only for the original paper sizes shown on the touch panel display.



**NOTE**

To select an A or B series paper size, press [A/B-size].

## Book Frame Erase



**IMPORTANT**

The Book Frame Erase mode cannot be used with the Document Size Select (11x17+, Auto, Other Size, and Long Strip Original) or Different Size Originals mode.

**1 Place your originals and specify the destination → press the Scan Settings drop-down list → [Option] → [Special Features] → [Frame Erase].**

For more information on specifying the destination, see Chapter 2, "Basic Sending Methods."

## 2 Press [Book Frame Erase].

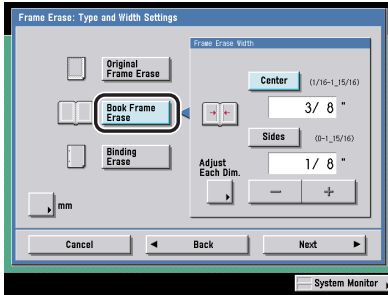

## 3 Press [-] or [+] to set the frame erase widths.

### ● If you want to set the same width for all four borders:

- Press [Center] and [Sides] → press [-] or [+] to set their respective frame erase widths → press [Next].

### ● If you want to set the top, left, center, right, and bottom widths independently:

- Press [Adjust Each Dim.].
- Select the desired frame erase borders → press [-] or [+] to set their respective frame erase widths → press [Next].

To return to the screen for setting the same width for all four borders, press [Adjust All At Once].

## 4 Select the size of the bound original when it is open → press [OK].

### IMPORTANT

You can set the Book Frame Erase mode only for the original paper sizes shown on the touch panel display.

### NOTE

To select an A or B series paper size, press [A/B-size].

# Binding Erase



## IMPORTANT

- The Binding Erase mode cannot be used with the Document Size Select (11x17+, Other Size, and Long Strip Original) or 2-Page Separation mode.
- Do not place originals with binding holes into the feeder, as this may damage the originals.
- If you are using the Binding Erase mode, the borders you do not select are also erased by 1/8" (4 mm).

### 1 Place your originals and specify the destination → press the Scan Settings drop-down list → [Option] → [Special Features] → [Frame Erase].

For more information on specifying the destination, see Chapter 2, "Basic Sending Methods."

### 2 Press [Binding Erase] → select the border where the binding holes are located.

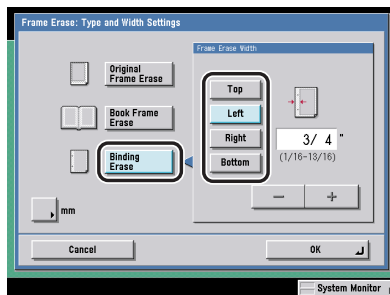

The border is where the binding holes are located on the original, if you visualize the original as being face up.

### 3 Press [-] or [+] to set the frame erase width → press [OK].

# Job Build

This mode enables you to scan originals that are too many to be placed at once, by dividing them into multiple batches. You can use both the feeder and the platen glass for scanning. The originals are sent as one document after all of the batches have been scanned.

## IMPORTANT

- The Job Build mode cannot be used with the Document Size Select (Other Size or Long Strip Original) mode.
- The Job Build mode cannot be used when sending a fax document in the Direct Sending or Manual Sending mode.
- You cannot change the scan settings while the machine is scanning originals in the Job Build mode. You need to set the necessary scan settings beforehand, according to the type of originals and the desired result.
- You can change or specify the following settings before scanning the next batch of originals (i.e., between batches): the Document Size Select (Auto or manual) mode, scan exposure, original type, 2-Sided Original, and color mode.
- If you place your originals into the feeder, remove the originals from the original output area when the scanning of each batch is complete.
- The maximum number of pages that can be sent at one time is 999. When using the Job Build mode, a message appears to ask you if you want to send the job when 999 pages of originals have been scanned. If you select to send the job, the scanned 999 pages are sent. If you cancel the job, the scanned pages are not sent.

## NOTE

- If you place different size originals into the feeder, set the Different Size Originals mode.
- If you want to scan one-sided and two-sided originals and store them as two-sided documents, divide the originals into one-sided and two-sided batches. For example, if the first batch consists of two-sided originals, set the 2-Sided Original mode. Thereafter, you have to manually set or cancel the 2-Sided Original mode for each batch of originals that you scan.

---

## **1 Place your originals and specify the destination → press the Scan Settings drop-down list → [Option] → [Special Features] → [Job Build].**

For more information on specifying the destination, see Chapter 2, "Basic Sending Methods."



**2** Press [Done] → [OK].

**3** Press  (Start).



**NOTE**

To cancel scanning, press [Cancel] or  (Stop).

**4** When scanning is complete, place your next batch of originals → press  (Start).

If you want to change the scan settings, change them before pressing  (Start).

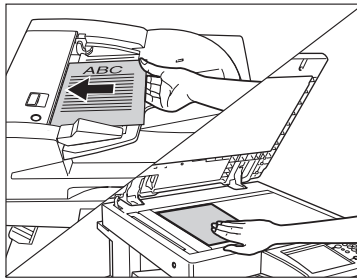

You can select the document size. (See "Document Size," on p. 3-8.)

You can change the scan exposure and the original type settings. (See "Scan Exposure and Original Type Settings," on p. 3-13.)

You can change the color mode setting. (See "Changing Color Modes," on p. 3-21.)

You can change the one-sided or two-sided original setting. (See "2-Sided Original," on p. 3-4.)

**● If the original is two-sided:**

Press [2-Sided Original].

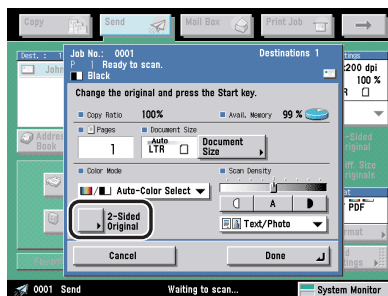

Select the type of two-sided original → press [OK].

Details of each item are shown below.

[Book Type]: The front and back sides of the original have the same top-bottom orientation.

[Calendar Type]: The front and back sides of the original have opposite top-bottom orientations.

Do not forget to set or cancel the 2-Sided Original mode, according to the type of originals that you place next.

To cancel the 2-Sided Original mode, press [2-Sided Original] → [Cancel].

Repeat this step as necessary.



#### IMPORTANT

The 2-Sided Original mode is available only if the optional Feeder (DADF-L1) (standard-equipped for Color imageRUNNER C3380i/C2880i) is attached.

**5** After the last batch of originals is scanned, press [Done].

# Adjusting the Contrast (Sharpness)

---

This mode enables you to scan original images with a sharper or softer contrast. To scan originals with text or lines with a sharper contrast, use [High] as the setting. To scan originals containing printed images or other halftones with a softer contrast, use [Low] as the setting.

## ■ Low

If you scan an original containing halftones, such as a printed image, using the Photo mode, the moiré effect (a shimmering, wavy pattern) may occur. In this case, you can lessen this moiré effect by using [Low] as the setting to produce a clearer image.

## ■ High

This setting enhances the edges of original images so that faint or fine text is scanned with a sharper contrast. This setting is particularly suited for scanning blueprints and faint pencil drawn images.

---

### **1 Place your originals and specify the destination → press the Scan Settings drop-down list → [Option] → [Special Features] → [Sharpness].**

For more information on specifying the destination, see Chapter 2, "Basic Sending Methods."

### **2 Press [Low] or [High] to adjust the sharpness → press [OK].**

To scan text or lines clearly, the setting should be towards [High]. To scan originals containing printed images or other halftones, the setting should be towards [Low].

# Image Quality Adjustment

You can adjust the scan exposure to erase the background color of the original, or prevent the original image on the reverse side of thin originals from appearing on the scanned pages.

## IMPORTANT

- Press [A] (Auto) if you want to set the machine to automatically adjust the scan exposure (see "Automatic Exposure Adjustment," on p. 3-16).
- If [A] (Auto) is selected as the scan exposure on the Scan Settings screen, pressing [Image Qual. Adjustment] and making fine adjustments cancels the automatic scan exposure setting. Similarly, if you select [A] (Auto) for the scan exposure setting when image quality adjustments have been made, the Image Quality Adjustment mode is canceled, and the automatic scan exposure setting is used instead.
- The Remove Background mode cannot be used with the Prevent Bleeding mode.

## ■ Remove Background

This mode enables you to scan by erasing the background color of the original. This mode is especially useful for scanning originals, such as catalogues and paper, that have turned yellow from age.

## ■ Prevent Bleeding

This mode enables you to prevent the original image on the reverse side of thin originals from appearing on the scanned pages.

## Remove Background

This mode enables you to scan by erasing the background color of the original. This mode is especially useful for scanning originals, such as catalogues and paper, that have turned yellow from age.

- 1 Place your originals and specify the destination → press the Scan Settings drop-down list → [Option] → [Special Features] → [Image Qual. Adjustment].**

For more information on specifying the destination, see Chapter 2, "Basic Sending Methods."

## 2 Press [Remove Background] → [OK].

If the background color remains, or if you want to make the background color darker when the original is scanned in the Remove Background mode, make fine adjustments to the density of the background color.

If you want to make fine adjustments to the density of the background color, press [Fine Adjustment] → press [-] or [+] to specify the amount of each color that you want to adjust → press [OK].

For example, if the background color (yellow) of the original remains, press [-] next to <Yellow> to adjust the density.

Adjusting Yellow automatically adjusts the levels of Red and Green to the same level as Yellow. However, adjusting the levels of Red or Green sets Yellow back to its default level.



### NOTE

- You can adjust the density of each color by pressing [-] or [+]. Press [-] to make the color lighter, or press [+] to make the color darker.
- If you make fine adjustments to the density, the automatic scan exposure setting is canceled, and the original is scanned according to the Fine Adjustment settings.

# Prevent Bleeding

This mode enables you to prevent the original image on the reverse side of thin originals from appearing on the scanned pages.

## 1 Place your originals and specify the destination → press the Scan Settings drop-down list → [Option] → [Special Features] → [Image Qual. Adjustment].

For more information on specifying the destination, see Chapter 2, "Basic Sending Methods."

## 2 Specify the amount of bleeding that you want to prevent.

Details of each item are shown below.

[-]: This setting prevents dark areas on the reverse side of the original from appearing on the scanned pages, but light areas on the front side may not be scanned either.

[+]: This setting may not be able to completely prevent dark areas on the reverse side of the original from appearing on the scanned pages, but light areas on the front side of the original are always scanned.

Press [Prevent Bleed-thru] → [Fine Adjustment].

Press [-] or [+] to specify the amount of bleeding that you want to prevent → press [OK] → [OK].



### NOTE

If you make fine adjustments to the density, the automatic scan exposure setting is canceled, and the original is scanned according to the Fine Adjustment settings.

# User Preset Keys

You can set any possible combination of scan settings and store them in a user preset key in memory. The user preset keys are available for the user to set and store, and can be assigned names for increased convenience. This feature is useful for storing frequently used scan settings.

Once user preset keys are stored, they are displayed in the Scan Settings drop-down list, and can be selected in the same way as the preset scan modes.

The scan modes stored in preset keys are: Clr/B&W 200 x 200 dpi, Clr/B&W 300 x 300 dpi, B&W 200 x 200 dpi, B&W 300 x 300 dpi, Clr/Gray 200 x 200 dpi, Clr/Gray 300 x 300 dpi, Clr/Gray 600 x 600 dpi, and B&W 600 x 600 dpi. (Clr stands for Color.)

## NOTE

- The scan settings stored as user preset keys in memory are not erased, even if the main power is turned OFF.
- There are eight user preset keys.
- You can change the settings and assign names for the preset scan keys.

## Storing Scan Settings

- 1** Press the Scan Settings drop-down list → press [Option] → specify the scan settings that you want to store.
- 2** Press [Store/Erase].

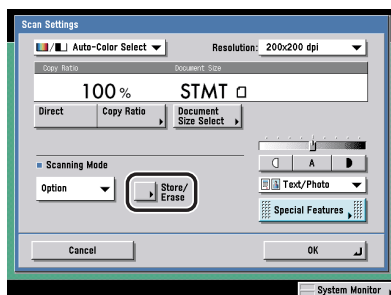

### 3 Select a user preset key for storing the scan settings → press [Store].

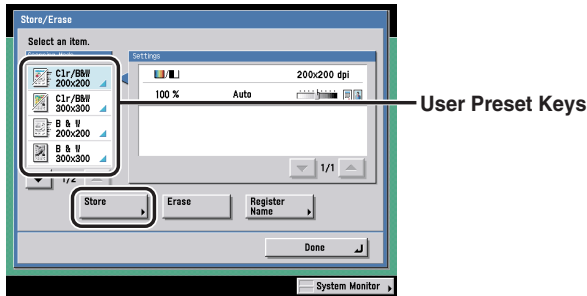

The table below describes the color selection modes and resolutions that can be stored in, and the icons displayed when color modes are stored.

Icon	Color Mode	Resolution
	Automatic Color Selection	100 x 100 dpi, 150 x 150 dpi, 200 x 100 dpi, 200 x 200 dpi
	Automatic Color Selection	200 x 400 dpi, 300 x 300 dpi, 400 x 400 dpi, 600 x 600 dpi
	Full Color	100 x 100 dpi, 150 x 150 dpi, 200 x 100 dpi, 200 x 200 dpi
	Full Color	200 x 400 dpi, 300 x 300 dpi, 400 x 400 dpi, 600 x 600 dpi
	Grayscale, Black-and-White*1	100 x 100 dpi, 150 x 150 dpi, 200 x 100 dpi*1, 200 x 200 dpi*1
	Grayscale, Black-and-White*1	200 x 400 dpi*1, 300 x 300 dpi, 400 x 400 dpi*1, 600 x 600 dpi
	(Not Stored)	

\*1 Displayed if only the optional Super G3 FAX Board or Super G3 Multi-Line Fax Board is installed.

#### NOTE

- Keys that already have settings stored in them are displayed with a colored triangle (▲) in the lower right corner of the key.
- If you select a key that already has settings stored in it, the settings are displayed.
- You can assign a name to a user preset key by pressing [Register Name].

#### ● If you select a key without settings:

- A screen appears, asking for your confirmation to store the settings → press [Yes].



● **If you select a key that already has settings stored in it:**

- A screen appears, asking for your confirmation to overwrite the previous settings → press [Yes].

## Naming a User Preset Key

**1 Press the Scan Settings drop-down list → [Option] → [Store/Erase].**

If necessary, see the screen shots in step 1 and step 2 of "Storing Scan Settings," on p. 4-17.

**2 Select a user preset key to name → press [Register Name].**

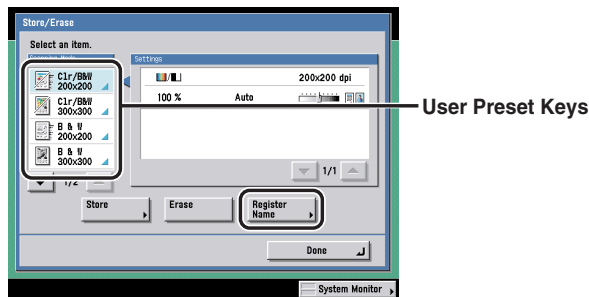

 **NOTE**

- Keys that already have settings stored in them are displayed with a colored triangle (▲) in the lower right corner of the key.
- If you select a key that already has settings stored in it, the settings are displayed.
- You can also name keys with no settings stored in them.

**3 Enter a name → press [OK].**

 **NOTE**

If you press [OK] without entering any characters, the key name changes to P1 to P8.

# Erasing Scan Settings

## 1 Press the Scan Settings drop-down list → press [Option] → [Store/Erase].

If necessary, see the screen shots in step 1 and step 2 of "Storing Scan Settings," on p. 4-17.

## 2 Select the user preset key with the scan settings that you want to erase → press [Erase].



### IMPORTANT

Make sure to check the settings first before erasing them.



### NOTE

- Keys that already have settings stored in them are displayed with a colored triangle (▲) in the lower right corner of the key.
- If you select a key that already has settings stored in it, the settings are displayed.

## 3 Press [Yes].



### NOTE

Key names are not erased. For instructions on changing a key name, see "Naming a User Preset Key," on p. 4-19.

# 5

## CHAPTER

# Sending Documents

This chapter describes the fundamental procedures for sending documents, how to configure send settings, and other useful features.

---

Sending Methods . . . . .	5-2
Sending a Fax . . . . .	5-2
Sending an E-Mail Message . . . . .	5-5
Sending an I-Fax . . . . .	5-8
Sending a Job to a File Server . . . . .	5-10
Sending a Job to a User Inbox . . . . .	5-13
Delaying a Send Job . . . . .	5-14
Job Done Notice . . . . .	5-16
Previewing Originals . . . . .	5-17
Stamping Originals . . . . .	5-19
Setting the File Format to Send a Document in . . . . .	5-21
Setting the File Format . . . . .	5-22
Sending a Compact PDF . . . . .	5-25
Trace & Smooth . . . . .	5-27
Sending a Searchable PDF . . . . .	5-28
Encrypting PDF Files . . . . .	5-29
Adding a Digital Signature to a PDF . . . . .	5-34
Job Recall . . . . .	5-38

# Sending Methods

You can enter the document's name, subject line, message body text, and replay-to address for document to be sent. Documents can be sent without changing any of the send settings, or you can configure them to suit your needs.

When you send a document, you can also send it at a preset time.

## IMPORTANT

If you send an image as a TIFF (Tagged Image File Format) file to a Macintosh, the recipient may not be able to view the image correctly. In this case, send the image as a PDF file, or view the TIFF file with an application, such as Apple QuickTime Player.

## NOTE

- For instructions on placing your originals, see Chapter 2, "Basic Operation," in the *Reference Guide*.
- For instructions on specifying destinations not registered in the Address Book, see "Specifying Destinations Using the New Address Tab," on p. 2-2.
- For instructions on specifying a User Inbox as a destination, see "Specifying a User Inbox," on p. 2-20.
- For instructions on specifying destinations stored in the Address Book, see "Using the Address Book," on p. 2-23.
- For instructions on specifying destinations using the one-touch buttons, see "Using the One-Touch Buttons," on p. 2-25.
- For instructions on specifying destinations and settings using the favorites buttons, see "Using the Favorites Buttons," on p. 2-26.
- For instructions on specifying a destination by searching through the directory listings on a server on the network using LDAP (Lightweight Directory Access Protocol), see "Using a Server," on p. 2-27.
- For instructions on setting the scan mode for your documents, see "Selecting a Scan Mode," on p. 3-2.
- If Direct Sending mode is set to 'Off' and Preview mode is set, you can verify the images from the Preview screen before sending your document. (See "Previewing Originals," on p. 5-17.)
- To cancel all settings and return the machine to the standard mode, press  (Reset).

## Sending a Fax

You can scan originals and send them as faxes. This section describes the procedure for specifying a sender's name.

 **NOTE**

This mode is available only if the optional Super G3 FAX Board or Super G3 Multi-Line Fax Board is installed.

■ **Memory Sending**

All of the originals to be sent are first scanned and read into memory, then sent. This means that you do not need to stay near the machine once the originals have been scanned.

 **NOTE**

The memory can hold a total of approximately 6,000 pages of sent and received documents.

■ **Direct Sending**

The machine sends each page of the document to the destination as it is scanned.

 **IMPORTANT**

- With Direct Sending mode, you can send a document of two or more pages only when using the feeder. You can only send one page at a time when you place your original on the platen glass.
- You can specify only one destination at a time for Direct Sending mode.
- Memory Sending is automatically set when using Delayed Send or when multiple destinations are specified.
- If an error occurs or you cancel transmission in the Direct Sending mode, you can check how many pages have been sent to the destination by printing the Fax Activity Report, or on the Log screen for Fax on the System Monitor screen.
- If the optional Super G3 Multi-Line Fax Board is installed, you can select which line to send with.

**1 Place your originals → specify the fax destination → press [Send Settings].**

**2 Specify each setting → press [Done].**

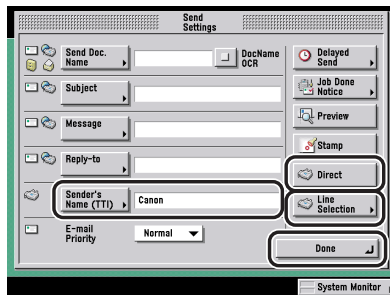

[Sender's Names (TTI)]:

Press [Sender's Names (TTI)] → select sender's name → press [OK].

The name registered under <00> is selected by default.

[Direct]:

You can select either the Direct Sending or Manual Sending mode by pressing [Direct].

To select the Direct Sending mode, press [Direct], and the key lights.

To select the Manual Sending mode, do not press [Direct], and the key remains unlit.

You can also set Direct Sending mode on the screen for specifying a new fax destination. (See "Specifying a Fax Number," on p. 2-2.)

[Line Selection]:

If the optional Super G3 Multi-Line Fax Board is installed, select the line to use for sending.

Select [Line 1], [Line 2], or [Auto] → press [OK].

[Line 1]: Standard line

[Line 2]: Additional line

[Auto]: Selects the line according to the setting for TX Line Selection in Dual Line Options under <Fax Settings> in Communications Settings (from the Additional Functions screen). (See "Selecting the Line for Sending," on p. 9-52.)



#### IMPORTANT

- You can restrict sending from line 1 or line 2. (See "Selecting the Line for Sending," on p. 9-52.)
- When using manual sending, line 1 is automatically selected, regardless of the line settings.
- When [Auto] is selected for [Line Selection], the user name displayed/printed on the recipient's machine will be the user name registered for the line which was used for sending.



#### NOTE

- To use this feature, you must register sender names beforehand. (See "Registering Sender Names," on p. 1-17.)
- The name registered as the user's name is displayed in <00> of the Sender's Name List. (See "Registering Sender Names," on p. 1-17.)
- If the optional Super G3 Multi-Line Fax Board is installed, the unit's name registered for the line that is selected for Priority TX in TX Line Selection in Dual Line Options under <Fax Settings> in Communications Settings (from the Additional Functions screen) is displayed. (See "Selecting the Line for Sending," on p. 9-52.)

### 3 Press (Start).

If you are using Direct Sending mode, it is automatically set to 'Off' after the transmission is complete.

## Sending an E-Mail Message

You can scan a document and send it as an attached file in an e-mail message. You can add the document's name, a subject line, message body text, and reply-to address. The scanned document can be sent as a JPEG, TIFF, or PDF file.

### IMPORTANT

If you are using Microsoft Exchange Server 5.5, 2000, or 2003, a sending error may occur when you send an e-mail message in the following cases:

- When a user is logged in to the machine using SDL or the Local Device Authentication system of SSO
- When <SMTP authentication (SMTP AUTH)> for <Authent./Encryption> in E-mail/I-Fax in Network Settings in System Settings (from the Additional Functions screen) is set to 'On'

In these cases, you should add the user logged in to the machine using SDL or the Local Device Authentication system of SSO to [Send on behalf of] in <Delivery Options> in Exchange General in Exchange. For more information, contact your system administrator.

### 1 Place your originals → specify the e-mail address → press [File Format].

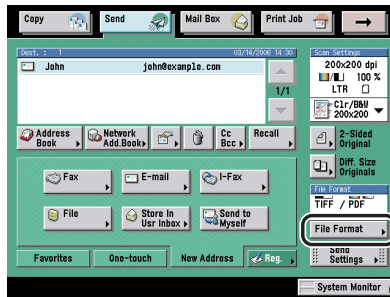

### 2 Select a file format.

#### NOTE

For instructions on setting the file format, see "Setting the File Format," on p. 5-22.

### 3 Press [Send Settings] → specify each setting → press [Done].

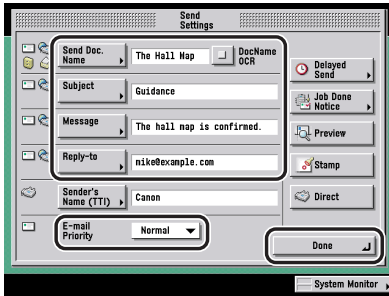

[Send Doc. Name]:

Press [Send Doc. Name] → enter the name of the document that you want to send → press [OK].

[DocName OCR]:

When [PDF (OCR)] is set as the file format, set [DocName OCR] to 'On' to automatically extract the first text block in the document for use as its filename. You can set the number of characters that are extracted for [DocName OCR] in <Num. of Char. for Doc. Name Setting> in PDF (OCR) Settings in TX Settings under <Common Settings> in Communications Settings (from the Additional Functions screen). (See "PDF (OCR) Mode," on p. 9-23.)

You can set from 1 to 24 characters for the size of the text block to be extracted. Characters such as "\", "/", "[", or "]", which are invalid when sending a file, will not be extracted.

If a document name is already entered, the extracted text is appended to the end of the filename. Characters over the character limit will be cut off.

The encrypted PDF mode and [DocName OCR] cannot be set at the same time.

[Subject]:

Press [Subject] → enter a subject of the e-mail message → press [OK].

[Message]:

Press [Message] → enter a message body text → press [OK].

[Reply-to]:

Press [Reply-to] → select a reply-to address → press [OK].

If Access Number Management in Restrict the Send Function in System Settings (from the Additional Functions screen) is set to 'On', and you want to select a destination that is stored with an access number, press [Access Number] → enter the access number. (See "Using the Address Book," on p. 2-23.)

The selected destination is set as the reply-to e-mail address.



[E-mail Priority]:

Press the E-mail Priority drop-down list → select a priority for your e-mail message.



### IMPORTANT

You need to store reply-to addresses in the Address Book beforehand. (See "E-Mail Addresses," on p. 10-9.)



### NOTE

- When you are sending documents, each page is sent as a separate image attached to an e-mail message, and the extension of the document matches the file format that you select for sending. The file name prefix of the image attached to the e-mail message is assigned as follows:
  - If you set the document's name:  
The file name prefix is generated by the document's name and three digits that signify the page number of the image.  
Example: document name\_002.tif
  - If you do not set the document's name:  
The file name prefix is generated by the job number (0001 to 4999) and three digits that signify the page number of the image.  
Example: 1231\_002.tif
- If you do not enter a subject, the default subject set in E-mail/I-Fax Settings is used. To access the E-mail/I-Fax Settings screen, press  (Additional Functions) → [System Settings] → [Communications Settings] → [E-mail/I-Fax Settings]. (See "E-Mail/I-Fax Settings," on p. 11-4.)
- You cannot select multiple destinations for the reply-to address.
- [Access Number] is displayed on the screen for selecting the reply-to address only if Access Number Management in Restrict the Send Function in System Settings (from the Additional Functions screen) is set to 'On'. (See "Access Number Management," on p. 11-16.)
- For instructions on storing your machine's e-mail address, see the *Network Guide*.

## 4 Press (Start).

# Sending an I-Fax

You can scan a document and send it to a destination via the Internet as an I-fax. An I-fax can only be sent to machines that can receive faxes via the Internet. You can add the document's name, a subject line, message body text, and reply-to address.

## IMPORTANT

If you are using Microsoft Exchange Server 5.5, 2000, or 2003, a sending error may occur when you send an I-fax in the following cases:

- When a user is logged in to the machine using SDL or the Local Device Authentication system of SSO
- When <SMTP authentication (SMTP AUTH)> for <Authent./Encryption> in E-mail/I-Fax in Network Settings in System Settings (from the Additional Functions screen) is set to 'On'

In these cases, you should add the user logged in to the machine using SDL or the Local Device Authentication system of SSO to [Send on behalf of] in <Delivery Options> in Exchange General in Exchange. For more information, contact your system administrator.

**1** Place your originals → specify the I-fax destination → press [Send Settings].

**2** Specify each setting → press [Done].



[Send Doc. Name]:

Press [Send Doc. Name] → enter a document name → press [OK].

[Subject]:

Press [Subject] → enter a subject of your I-fax → press [OK].

[Message]:

Press [Message] → enter a message body text → press [OK].

[Reply-to]:

Press [Reply-to] → select a reply-to address → press [OK].

If Access Number Management in Restrict the Send Function in System Settings (from the Additional Functions screen) is set to 'On', and you want to select a destination that is stored with an access number, press [Access Number] → enter the access number. (See "Using the Address Book," on p. 2-23.)

A Full Mode Delivery Confirmation message will be sent to the selected reply-to address also.



#### IMPORTANT

You need to store reply-to addresses in the Address Book beforehand. (See "E-Mail Addresses," on p. 10-9.)



#### NOTE

- When you are sending documents, each page is sent as a separate TIFF image attached to the I-fax. The file name prefix of the image attached to the I-fax is assigned as follows:
  - If you set the document's name:  
The file name prefix is generated by the document's name and three digits that signify the page number of the image.  
Example: document name\_001.tif
  - If you do not set the document's name:  
The file name prefix is generated by the job number (0001 to 4999) and three digits that signify the page number of the image.  
Example: 1231\_001.tif
- If you do not enter a subject, the default subject set in E-mail/I-Fax Settings is used. To access the E-mail/I-Fax Settings screen, press (Additional Functions) → [System Settings] → [Communications Settings] → [E-mail/I-Fax Settings]. (See "E-Mail/I-Fax Settings," on p. 11-4.)
- You cannot select multiple destinations for the reply-to address.
- [Access Number] is displayed on the screen for selecting the reply-to address only if Access Number Management in Restrict the Send Function in System Settings (from the Additional Functions screen) is set to 'On'. (See "Access Number Management," on p. 11-16.)
- For instructions on storing your machine's e-mail address, see the *Network Guide*.

### 3 Press (Start).

# Sending a Job to a File Server

You can send a job to any computer that acts as a file server on the network. The following procedure explains how to specify the document's name and the file format of the image you are sending.

- 1 Place your originals → specify the file server's destination → press [File Format].**

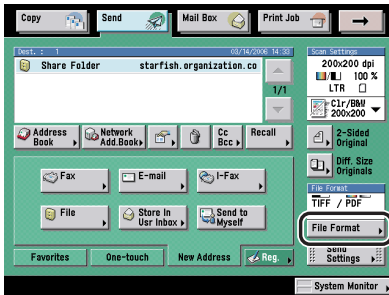

- 2 Select a file format.**



## NOTE

For instructions on setting the file format, see "Setting the File Format," on p. 5-22.

### 3 Press [Send Settings] → specify a send document name → press [Done].

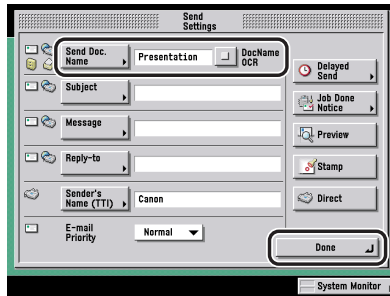

[Send Doc. Name]:

Press [Send Doc. Name] → enter the document name → press [OK].

[DocName OCR]:

When [PDF (OCR)] is set as the file format, set [DocName OCR] to 'On' to automatically extract the first text in the document for use as its filename. You can set the number of characters that are extracted for [DocName OCR] in <Num. of Char. for Doc. Name Setting> in PDF (OCR) Settings in TX Settings under <Common Settings> in Communications Settings (from the Additional Functions screen). You can set from 1 to 24 characters for this setting. (See "PDF (OCR) Mode," on p. 9-23.)

The first text block extracted from the first page of the document is automatically set as the document name. Characters such as ",", "/", "[", or "]", which are invalid when sending a file, will not be extracted.

If a document name is already entered, the extracted text is appended to the end of the filename. Characters over the character limit will be cut off.

The encrypted PDF mode and [DocName OCR] cannot be set at the same time.



#### IMPORTANT

If you use characters such as ",", "/", "[", or "]" in the document name, you may not be able to send the file to file servers that run on operating systems that do not recognize such characters.



## NOTE

- When you are sending documents, each page is sent as a separate image and stored in a file server. The extension of the document matches the file format that you select for sending. The file name prefix of the image attached to the document you are sending is assigned as follows:

- If you set the document's name and Divide into Pages is turned on:

The file name prefix is generated by the document's name, the year, month, day, hour, minute, and second the document is sent, and the five digits that signify the page number of the image.

Example:

document name\_20060410203000\_00002.tif

document name\_20060410203000\_00002.pdf

- If you set the document's name and Divide into Pages is not turned on:

The file name prefix is generated by the document's name and the year, month, day, hour, minute, and second the document is sent.

Example:

document name\_20060410203000.tif

document name\_20060410203000.pdf

- If you do not set the document's name and Divide into Pages is turned on:

The file name prefix is generated by the year, month, day, hour, minute, and second the document is sent, and the five digits that signify the page number of the image.

Example:

20060410203000\_00002.tif

20060410203000\_00002.pdf

- If you do not set the document's name and Divide into Pages is not turned on:

The file name prefix is generated by the year, month, day, hour, minute, and second the document is sent.

Example:

20060410203000.tif

20060410203000.pdf

## 4 Press (Start).

# Sending a Job to a User Inbox

You can scan a document and store it in a User Inbox. If you include a User Inbox as one of the destinations to which you are sending your document, the document is stored in the selected User Inbox for later use. Documents stored in a User Inbox can be printed and sent to other destinations. The following procedure explains how to specify the document's name when you want to send it to a User Inbox.

## IMPORTANT

- A document stored in a User Inbox is automatically erased after three days. However, you can set the time that must elapse before the documents in an inbox are automatically erased. (See Chapter 7, "Customizing Settings," in the *Copying and Mail Box Guide*.)
- Additional documents cannot be stored in the User Inbox under the following conditions. (These numbers may vary depending on the remaining capacity of the hard disk.)
  - When 1,500 documents have been stored in any or all of the inboxes
  - When 6,000 pages have been stored in any or all of the inboxes

## NOTE

- It is recommended that you delete unnecessary documents or image data from the User Inboxes to make space for storing new documents.
- For more information on User Inboxes, see the *Copying and Mail Box Guide*.

**1** Place your originals → specify the desired User Inbox → press [Send Settings].

**2** Specify a send document name → press [Done].

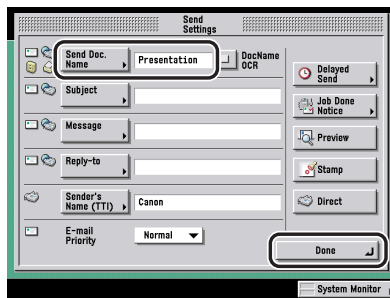

[Send Doc. Name]:

Press [Send Doc. Name] → enter a document name → press [OK].

**3** Press  (Start).

## Delaying a Send Job

The Delayed Send mode enables you to store a send job in memory, and have it sent at a later time.

### NOTE

- You can reserve up to 120 jobs (including 64 fax jobs) for delayed sending. However, the actual number of jobs that can be reserved may be less than 120, depending on the following conditions:
  - If multiple documents are being sent at the same time
  - If large document files are being sent
- The number of delayed send jobs which you can reserve may also be reduced if there are other jobs with no Delayed Send settings, or if there are other factors affecting the specified destinations.
- Once the delayed documents are sent, the documents are automatically deleted from memory.
- You can check the status, cancel, or change the destinations of documents for which a preset send time has been specified. (See "Using the System Monitor Screen," on p. 1-36, and Chapter 8, "Checking/Changing the Send/Receive Status.")
- If multiple send jobs reach their delayed send time simultaneously, documents are sent in the following order:

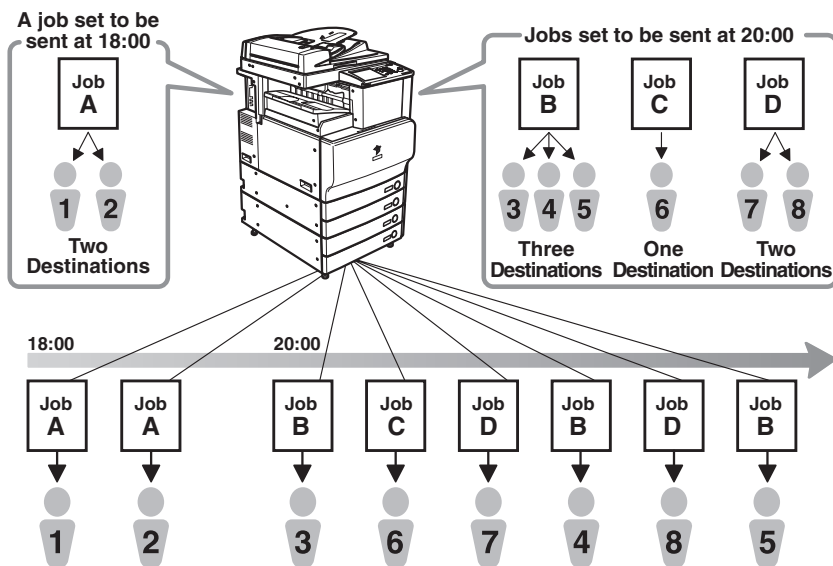

- 1** Place your originals → specify the destination → press [Send Settings].



## 2 Press [Delayed Send].

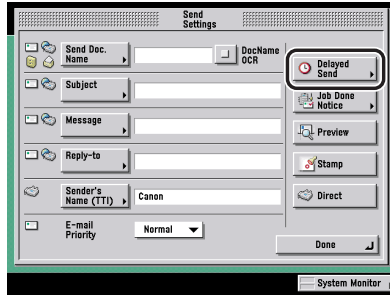

## 3 Enter the send time using 0 - 9 (numeric keys).

Enter all four digits of the time (including zeros), using 24-hour notation.

Examples: 7:05 a.m. → 0705

11:18 p.m. → 2318

If you set a time earlier than the current time, the document will be sent at that time on the next day.



### NOTE

If you make a mistake when entering the send time, press © (Clear) to clear your entry → enter another four digit number.

## 4 Press [OK] → [Done].

## 5 Press ⏪ (Start).



### NOTE

- To cancel the currently set Delayed Send settings, press [Send Settings] → [Delayed Send] → [Cancel].
- You can only cancel delayed send jobs from the System Monitor screen. (See "Using the System Monitor Screen," on p. 1-36.)

# Job Done Notice

You can send a job done notice to a specified e-mail address to notify you when a send job is complete.

## IMPORTANT

To send a job done notice, you need to store e-mail addresses in the Address Book beforehand. (See "Storing New Addresses," on p. 10-5.)

**1** Place your originals → specify the destination → press [Send Settings].

**2** Press [Job Done Notice].

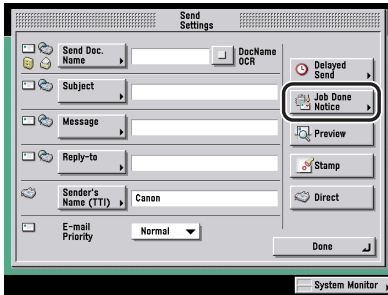

**3** Select the destination where the job done notice is to be sent → press [OK].

If Access Number Management in Restrict the Send Function in System Settings (from the Additional Functions screen) is set to 'On', and you want to select a destination that is stored with an access number, press [Access Number] → enter the access number. (See "Using the Address Book," on p. 2-23.)

## NOTE

- [Access Number] is displayed on the screen only if Access Number Management in Restrict the Send Function in System Settings (from the Additional Functions screen) is set to 'On'. (See "Access Number Management," on p. 11-16.)
- To cancel a selected e-mail address, select the address again.
- You cannot select multiple destinations at the same time.

**4** Press [Done].

## 5 Press (Start).



### NOTE

To cancel this setting, press [Send Settings] → [Job Done Notice] → [Cancel].

## Previewing Originals

This mode enables you to preview the scanned data of your originals and to check the page count before sending your document. You can verify the scanned data of your originals on the Preview screen.



### IMPORTANT

The Preview mode cannot be used when sending a fax document with the Direct Sending or Manual Sending mode.

**1 Place your originals → specify the destination → press [Send Settings].**

**2 Press [Preview] → [Done].**

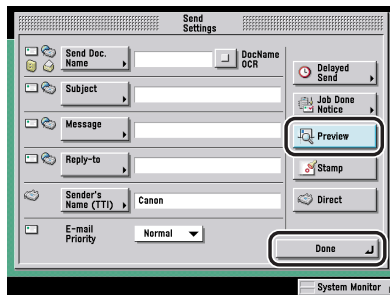

[Preview] is lit when it is on.

[Preview] is not lit when it is off.

**3 Press  (Start).**



### NOTE

If the Preview key is not lit, the Preview display setting is turned off, and the Preview screen is not displayed. In this case, the scanned data is sent to the specified destination when scanning is complete.

## 4 Press [◀] or [▶] to specify the page that you want to verify.

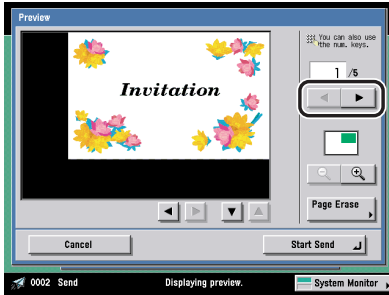

## 5 Select whether to erase the page.

To erase the page, press [Page Erase].

If you do not want to erase the page, proceed to step 9.

## 6 Select [Erase Single Page] or [Erase Pages Consecutively] → select the pages you want to erase.

### ● If you select [Erase Single Page]:

- Press [-] or [+] to specify the page you want to erase.

### ● If you select [Erase Pages Consecutively]:

- Press [First Page] and [Last Page] to specify the first and the last page of the range you want to erase by pressing [-] or [+].

## 7 Press [Start].

## 8 Press [Yes].

## 9 Verify the images → press [Start Send].

You can press [🔍] (reduce) or [🔍] (enlarge) to zoom in or out.

You can press [◀], [▶], [▼], or [▲] to specify the area to display when you zoom in or out on the page.

When your image is enlarged or reduced, you can see the general location of which area you are previewing with  (above the reduce and enlarge icons).

 **NOTE**

The number of scanned pages is displayed on the Send Process screen.

## Stamping Originals

The machine can print a stamp (approximately 1/8" (3 mm) in diameter) on the front side of scanned and sent originals.

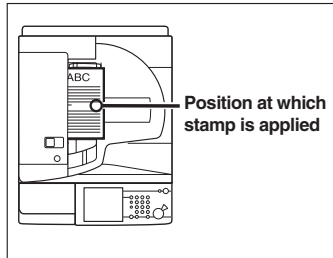

**Vertical Placement**

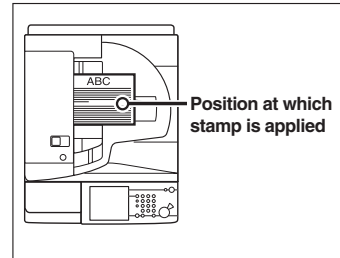

**Horizontal Placement**

 **IMPORTANT**

- The Stamp mode cannot be used with the Document Size Select (Other Size) or 2-Page Separation mode.
- The Stamp mode cannot be used when sending a fax document in the Direct Sending or Manual Sending mode.

 **NOTE**

The stamp is applied to the originals that are scanned from the feeder.

---

**1 Place your originals in the feeder → specify the destination → press [Send Settings].**

 **NOTE**

You can also set the Stamp mode by pressing [Stamp] in Edit Standard Send Settings in TX Settings under <Common Settings> in Communications Settings (from the Additional Functions).

## 2 Press [Stamp] → [Done].

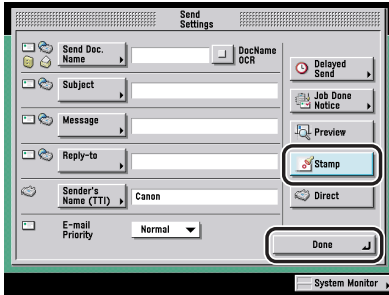

To cancel the Stamp mode, press [Stamp] again.

## 3 Press (Start).

### NOTE

If the stamp is not marked clearly, see Chapter 7, "Routine Maintenance," in the *Reference Guide*.

# Setting the File Format to Send a Document in

---

You can select TIFF, JPEG or PDF as the file format to send a document in. If you select PDF as the file format, you can also specify the Trace and Smooth, Compact, OCR (Text Searchable), Encrypt, and/or Add Digital Signatures modes.

## NOTE

- For instructions on placing your originals, see Chapter 2, "Basic Operation," in the *Reference Guide*.
- For instructions on specifying addresses not registered in the Address Book, see "Specifying Destinations Using the New Address Tab," on p. 2-2.
- For instructions on specifying addresses using the Address Book, see "Using the Address Book," on p. 2-23.
- For instructions on specifying addresses using the one-touch buttons, see "Using the One-Touch Buttons," on p. 2-25.
- For instructions on specifying addresses and settings using the favorites buttons, see "Using the Favorites Buttons," on p. 2-26.
- For instructions on specifying a destination by searching through the directory listings on a server on the network using LDAP (Lightweight Directory Access Protocol), see "Using a Server," on p. 2-27.
- For instructions on setting the scan mode for your documents. See "Selecting a Scan Mode," on p. 3-2.
- Specify an e-mail or file server destination.
- You can verify the images from the Preview screen before sending your document. (See "Previewing Originals," on p. 5-17.)
- To cancel all settings and return the machine to the standard mode, press  (Reset).

# Setting the File Format

You can send a scanned document to a file server or as an e-mail attachment. The following procedure explains how to set the file format of the sent document.

- 1 Place your originals and specify the destination → press [File Format].

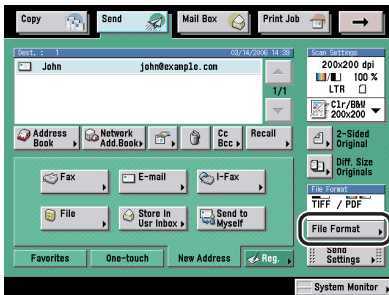

- 2 Select a file format.

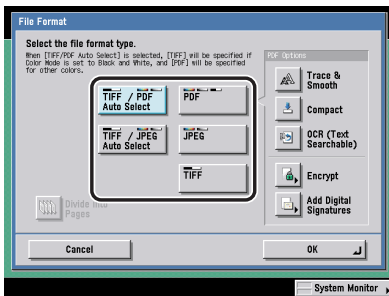

[File Formats]:

[TIFF/PDF Auto Select]: Sends the file in either the TIFF (Black-and-White) or PDF (Grayscale/Color) format. If you select this file format, [TIFF/PDF] is displayed on the Send Basic Features screen.

[TIFF/JPEG Auto Select]: Sends images in either the TIFF (Black-and-White) or JPEG (Grayscale/Color) format. If you select this file format, [TIFF/JPEG] is displayed on the Send Basic Features screen.



- [PDF]: Sends the file in the PDF format regardless of the color mode. You can also specify [Trace & Smooth], [Compact], [OCR (Text Searchable)], [Encrypt], and/or [Add Digital Signatures].
- [JPEG]: Sends the file in the JPEG format, if you select a color mode other than Black-and-White.
- [TIFF]: Sends the file in the TIFF format, only if you select the Black-and-White mode.

● **If you select [TIFF/PDF Auto Select], [TIFF/JPEG Auto Select], or [JPEG] as the file format:**

- Press [OK].

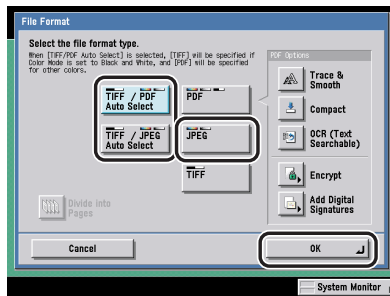

If you select [TIFF/PDF Auto Select], the Divide into Pages mode is not available.

If you select [TIFF/JPEG Auto Select] or [JPEG], [Divide into Pages] is set to 'On'.

**● If you select [PDF] or [TIFF] as the file format:**

- Specify whether to divide your documents into separate pages → press [OK].

If you want to separate multiple images and send them as separate files, each of which consists of only one page, press [Divide into Pages], and the key lights.

If you want to send multiple images as a single file without dividing them, do not press [Divide into Pages], and the key remains unlit.

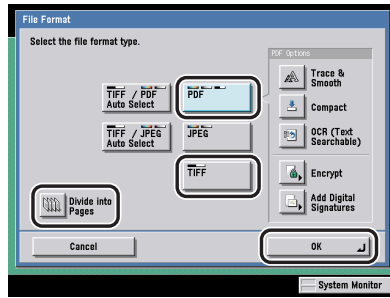

You can select the type of PDF from <PDF options>.

For information on the type of PDF, see the following sections.

- [Compact]: See "Sending a Compact PDF," on p. 5-25.
- [Trace & Smooth]: See "Trace & Smooth," on p. 5-27.
- [OCR (Text Searchable)]: See "Sending a Searchable PDF," on p. 5-28.
- [Encrypt]: See "Encrypting PDF Files," on p. 5-29.
- [Add Digital Signatures]: See "Adding a Digital Signature to a PDF," on p. 5-34.

**NOTE**

- To view a PDF file or to search a text in a PDF file, software that supports the PDF format (such as Adobe Reader/Adobe Acrobat) is required.
- To view a JPEG file, software that supports the JPEG format (such as Microsoft Internet Explorer for Windows) is required.
- To view a TIFF file, software that supports the TIFF format (such as Imaging for Windows) is required.

**3 Press  (Start).**

# Sending a Compact PDF

This mode enables you to send files containing text originals or text/photo originals using a high compression ratio. The Auto-Color Select (Full Color/Black-and-White) and Black-and-White color modes cannot be used together when [Compact] is selected. If you select [Compact] as the PDF file format, it is recommended that you set the original type setting to either 'Text/Photo' or 'Text', depending on the image type. If you select [Compact], [PDF (Compact)] is displayed as the file format on the Send Basic Features screen. You can also select [OCR (Text Searchable)].

## IMPORTANT

You cannot send a compact PDF in any of the following cases:

- If the color mode for the document is Black-and-White
- If the color mode for the document is Full Color/Grayscale (Automatic Color Selection) and the resolution is set to less than 300 dpi
- If the document is a long strip original (33 7/8" (860 mm) or longer) (long strip originals of up to 24 7/8" (630 mm) can be scanned using the scanning area of the machine, but long strip originals longer than 24 7/8" (630 mm) can only be received by I-fax, etc.)

## NOTE

This mode is available only if the optional Universal Send PDF Advanced Feature Set is activated.

## 1 Place your originals and specify the destination → press [File Format].

If necessary, see the screen shot in step 1 of "Setting the File Format," on p. 5-22.

## 2 Press [Compact].

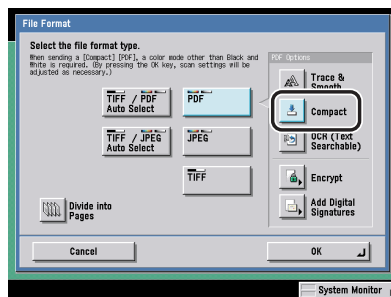

### 3 Specify whether to divide your documents into separate pages → press [OK].

If you want to separate multiple images and send them as separate files, each of which consists of only one page, press [Divide into Pages], and the key lights.

If you want to send multiple images as a single file without dividing them, do not press [Divide into Pages], and the key remains unlit.

#### IMPORTANT

- If [Compact] is selected for the PDF file format, the resolution is automatically changed to [300x300 dpi]. If the color mode is set to [Auto-Color Select (Full Color/Black-and-White)] or [Black and White], the color mode is automatically changed to [Auto-Color Select (Full Color/Grayscale)] or [Grayscale], respectively. If you want to send the document with the resolution setting and the color mode that you specify, change the PDF file format to anything other than [Compact] or [Trace & Smooth].
- If [PDF (Compact)] is selected as the file format in Standard Send Settings in Edit Standard Send Settings in TX Settings under <Common Settings> in Communications Settings (from the Additional Functions screen) and you are sending documents by fax or I-fax, a message prompting you to change the file format may appear on the screen. In this case, change the file format to anything other than [PDF (Compact)] or [PDF (Trace)].
- If [PDF (Compact)] is selected as the file format, documents can be sent only at a zoom ratio of 100%.

#### NOTE

- To view a PDF file or to search a text in a PDF file, software that supports the PDF format (such as Adobe Reader/Adobe Acrobat) is required.
- If you select [Compact], you can also set [OCR (Text Searchable)] at the same time. In that case, [PDF (Compact)] is displayed as the file format on the Send Basic Features screen.
- For more information on the different file formats, see "File formats," in the Glossary on p. 14-28.

### 4 Press (Start).

# Trace & Smooth

Trace & Smooth is an advanced setting of compact PDF, which enables you to convert the text and the line drawings of a scanned image to scalable outline data. The outline data (Trace) can be extracted and used in Adobe Illustrator. The smoothing process can also be applied to the text of the outline data, so it has less of a jagged edge when seen on a PC monitor or in print.

## IMPORTANT

- If you set the Trace & Smooth mode, the machine automatically recognizes which parts of the document are text or line drawings. the machine may not recognize which parts of the scanned document are text and line drawings correctly, depending on the scanned document.
- If you set the Trace & Smooth mode, smoothing is only performed on the areas of the document that are correctly recognized as text.
- The text and background of a PDF containing outline data may become misaligned when opened in Adobe Illustrator, depending on the version of Adobe Illustrator used to open the PDF.
- Long strip originals of up to 17" (432 mm) in length can be used with the Trace & Smooth mode.

## NOTE

- This mode is available only if the optional Universal Send PDF Advanced Feature Set is activated.
- The Trace & Smooth mode cannot be set by itself. If you select [Trace & Smooth], [Compact] is automatically set to 'On'.

## 1 Place your originals and specify the destination → press [File Format].

If necessary, see the screen shot in step 1 of "Setting the File Format," on p. 5-22.

## 2 Press [Trace & Smooth].

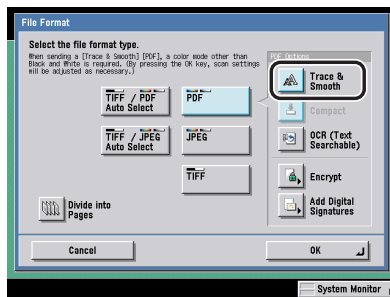

### 3 Follow steps 3 and 4 of "Sending a Compact PDF," on p. 5-25.

## Sending a Searchable PDF

This mode enables you to perform OCR (optical character recognition) to extract data that can be recognized as text from the scanned image, and add it as a transparent layer of text to create a PDF file that is searchable.

#### IMPORTANT

PDF (OCR) and Long Strip Original (17" (432 mm) or more) cannot be set at the same time.

#### NOTE

This mode is available only if the optional Universal Send PDF Advanced Feature Set is activated.

### 1 Place your originals and specify the destination → press [File Format].

If necessary, see the screen shot in step 1 of "Setting the File Format," on p. 5-22.

### 2 Press [OCR (Text Searchable)].

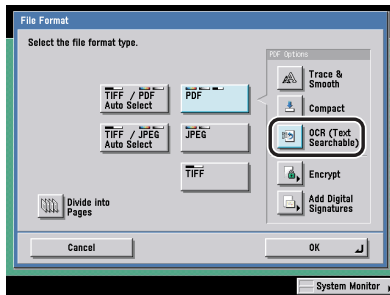

### 3 Specify whether to divide your documents into separate pages → press [OK].

If you want to separate multiple images and send them as separate files, each of which consists of only one page, press [Divide into Pages], and the key lights.

If you want to send multiple images as a single file without dividing them, do not press [Divide into Pages], and the key remains unlit.

 **IMPORTANT**

Even if [PDF (OCR)] is selected as the file format, text may not be detected correctly, depending on the background color, style and size of the characters in the image.

 **NOTE**

- To view a PDF file or to search a text in a PDF file, software that supports the PDF format (such as Adobe Reader/Adobe Acrobat) is required.
- For more information on the different file formats, see "File formats," in the Glossary on p. 14-28.
- If you select [PDF (OCR)] as the file format, and <Smart Scan> in PDF (OCR) Settings in TX Settings under <Common Settings> in Communications Settings (from the Additional Functions screen) is set to 'On', the orientation of the original is detected, and the document is automatically rotated, if necessary, before it is sent. (See "PDF (OCR) Mode," on p. 9-23.)
- If you select [OCR (Text Searchable)], you can also set [Compact] at the same time. In that case, [PDF (Compact)] is displayed as the file format on the Send Basic Features screen.

## 4 Press (Start).

### Encrypting PDF Files

This mode enables you to encrypt PDF files that you send to an e-mail address or file server for enhanced security. If a password is set for a PDF file, only users who enter the correct password at the other party's machine can open, print, or change the received PDF.

 **IMPORTANT**

This mode can be used only if an e-mail address or file server is specified as the destination. If a fax number, I-fax address, or inbox is specified as the destination, you cannot send the job as an encrypted PDF file.

 **NOTE**

- This mode is available only if the optional Universal Send PDF Security Feature Set is activated.
- The encrypted PDF mode and [DocName OCR] cannot be set at the same time.

## 1 Place your originals → specify the destination → press [File Format].

If necessary, see the screen shots in step 1 of "Setting the File Format," on p. 5-22.

## 2 Press [Encrypt].

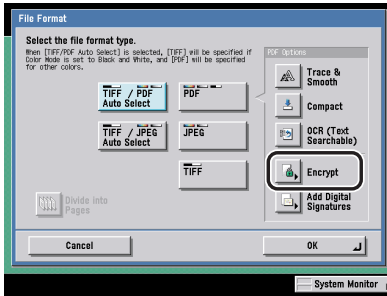

## 3 Specify each setting → press [OK].

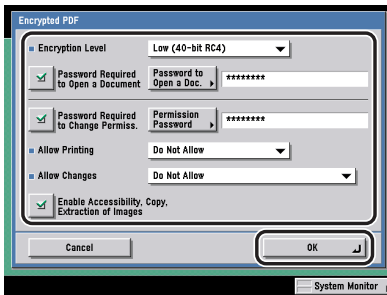

<Encryption Level>:

Press the Encryption Level drop-down list → select [Low (40-bit RC4)] or [High (128-bit RC4)].

Adobe Acrobat 5.0 or later is required for opening PDF files whose encryption level is set to [High (128-bit RC4)].

[Password Required to Open a Document]:

Select this key to set a password for opening the received PDF files. You can specify a password by pressing [Password to Open a Doc.].

The received encrypted PDF files cannot be opened without entering the password.

[Password to Open a Doc.]:

Press [Password to Open a Doc.] → enter the password → press [OK].

Re-enter the password for confirmation on the Confirm screen → press [OK].

[Password Required to Change Permiss.]:

Select [Password Required to Change Permiss.] to set a password for printing or editing the received PDF file. When selecting this key, you can specify detailed settings, such as [Allow Printing], [Allow Changes], and [Enable Accessibility, Copy, Extraction of Images]. Set the password in [Permission Password].



If [Password Required to Change Permiss.] is set, the received encrypted PDF files cannot be printed or edited without entering the password.

[Permission Password]:

Press [Permission Password] → enter the password → press [OK].

Re-enter the password for confirmation on the Confirm screen → press [OK].

<Allow Printing>:

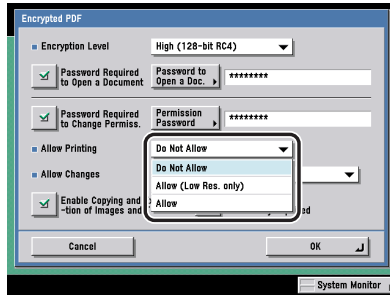

If [High (128-bit RC4) is selected as the encryption level

Press the Allow Printing drop-down list → select whether to allow printing of the received PDF files. You can select this setting only if [Password Required to Change Permiss.] is set to 'On'.

- [Do Not Allow]: Printing is not allowed. Even if [Do Not Allow] is selected, the document can be printed if it is opened with the permission password if the recipient is using Adobe Acrobat 5 or earlier.
- [Allow (Low Res. only)]: Only low-resolution printing is allowed. ([Allow (Low Res. only)]) is displayed only if [High (128-bit RC4)] is selected.)
- [Allow]: Printing is allowed.

<Allow Changes>:

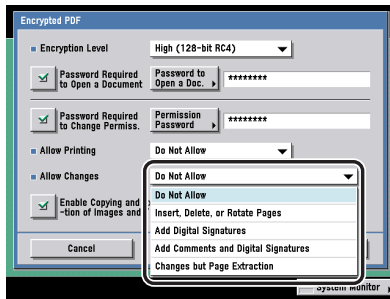

If [High (128-bit RC4)] is selected as the encryption level

Press the Allow Changes drop-down list → select whether to allow changing of the received PDF files. You can select this setting only if [Password Required to Change Permiss.] is set to 'On'.

- [Do Not Allow]: Changing of documents is not allowed.
- [Insert, Delete, or Rotate Pages]: Inserting, deleting and rotating pages is allowed. ([Insert, Delete, or Rotate Pages] is displayed only if [High (128-bit RC4)] is selected.)
- [Add Digital Signatures]: Adding digital signatures is allowed. ([Add Digital Signatures] is displayed only if [High (128-bit RC4)] is selected.)
- [Add Comments and Digital Signatures]: Adding comments and digital signatures is allowed.
- [Changes but Comment Add/Page Extract.]: Changing of documents except for adding comments and extracting pages is allowed. ([Changes except Comment Add/Page Extract.] is displayed only if [Low (40-bit RC4)] is selected.)
- [Changes but Page Extraction]: Changing of documents except for extracting pages is allowed.

[Enable Accessibility, Copy, Extraction of Images]:

You can select this setting only if [Password Required to Change Permiss.] is set to 'On'.

If [Low (40-bit RC4)] is selected, you can select this setting. Select this key to allow copying of images and page extraction. In addition, it also has a function for reading aloud text inside a document for the visually impaired.

If [High (128-bit RC4)] is selected, [Enable Copying and Extraction of Image and Text] and [Enable Access for the Visually Impaired] are displayed and you can set these settings separately.



### IMPORTANT

- If you did not enter a password in [Password to Open a Doc.] or [Permission Password], enter the password in the screen that appears after pressing  (Start). You can store the settings for encrypted PDF files in a favorites button. If you do not want to set a password for [Password to Open a Doc.] and [Permission Password] in a favorites button, leave their text boxes blank.
- If you recall the Encrypted PDF settings by pressing [Recall], [Password to Open a Doc.] and [Permission Password] become blank.
- You cannot set the same password for both [Password to Open a Doc.] and [Permission Password].
- [Password to Open a Doc.] and [Permission Password] are displayed as asterisks (\*\*\*\*\*) on the Encrypted PDF screen.
- Even if you set restrictions for a PDF file with [Permission Password], some of these restrictions may be ignored if the recipient opens the PDF with certain software.



### NOTE

- To open or print a PDF file, software that supports the PDF format (such as Adobe Reader/Adobe Acrobat) is required.
- To change a PDF file or to enable copying and extraction of images, Adobe Acrobat is required.
- Adding digital signatures and comments, and the ability to insert, delete, and rotate pages are features of Adobe Acrobat.
- If Use Asterisks to Enter Access No./Passwords in System Settings (from the Additional Functions screen) is set to 'Off', the password that you enter on the Password Required to Open a Document screen and the Permission Password screen is not displayed as asterisks. (See Chapter 6, "System Manager Settings," in the *Reference Guide*.)

## 4 Press [Done].

## 5 Press (Start).



### NOTE

- If fax, I-fax, or User Inbox destinations are specified, the message telling you the send job is canceled appears. Press [OK] → check the destinations.
- To cancel the settings, press [File Format] → [Encrypt] → [Cancel].

# Adding a Digital Signature to a PDF

This mode enables you to send PDF documents with a digital signature.

You can add the following two types of digital signatures:

## ■ Device Signature

This mode uses the device signature certificate and key pair inside the machine to add a digital signature to the document, which enables the recipient to verify which device scanned it. The recipient can verify the device that signed the document, and whether the document has been changed after it was signed.

## ■ User Signature

This mode uses information about the user currently logged in to the machine using a SDL or SSO login service and the user signature certificate and key pair inside the machine to add a digital signature to the document, which enables the recipient to verify which user signed it. The recipient can verify the user that signed the document, and whether the document has been changed after it was signed.

### IMPORTANT

- You can add only a digital signature to documents sent in either the PDF (Trace), PDF (Compact), or PDF (OCR) file format. You cannot add a digital signature to documents sent in the TIFF or JPEG format.
- If an error occurs when sending a multiple page PDF document with a digital signature, the document will not be able to be opened by the recipient.

### NOTE

- If you select to add both a device signature and user signature, the device signature is added before the user signature.
- If the recipient verifies a PDF that has had both a device signature and user signature added to it using software that supports the PDF format (such as Adobe Reader/Adobe Acrobat), only the user signature can be verified. The device signature causes the document to be handled as if it has been altered.
- If you change the file format to a format other than 'PDF' after setting to add a digital signature, a message confirming whether you want to change the file format is displayed. If you change the file format, the digital signatures you have set to add are canceled.
- For information on validating certificates, registering certificates in the trusted certificates list, and verifying signatures on the recipient side, see the documentation for the software that supports the PDF format (such as Adobe Reader/Adobe Acrobat).

## Adding a Device Signature

### NOTE

- This mode is available only if the optional Universal Send PDF Security Feature Set is activated.
- You can only add device signatures to PDF documents if the optional Universal Send PDF Security Feature Set is activated and you have generated a device signature certificate and key pair in Network Settings in System Settings (from the Additional Functions screen). For more information, see Chapter 3, "Using a TCP/IP Network," in the *Network Guide*.
- <Certificate Thumbprint> contains sender information used to validate the reliability of a PDF with a device signature, by matching it with the MD5 or SHA-1 message digest number. For more information on confirming <Certificate Thumbprint> and other device signature information, see "Confirming the Device Signature Certificate," on p. 9-25, or Chapter 3, "Using a TCP/IP Network," in the *Network Guide*.
- If the SDL or SSO login service is set and an e-mail address is registered for the user, in addition to adding the device signature, the [Author] property of the PDF is set to the e-mail address of the user.

## 1 Place your originals → specify the destination → press [File Format].

If necessary, see the screen shot in step 1 of "Setting the File Format," on p. 5-22.

## 2 Press [Add Digital Signatures].

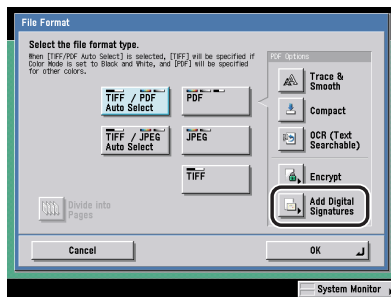

### 3 Press [Device Signature] → [OK] → [OK].

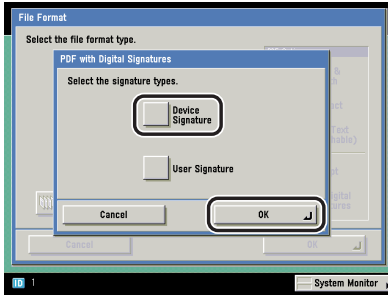

### 4 Press (Start).

## Adding a User Signature

You can add a user signature using information about the user currently logged in to the machine using a login service and the user signature certificate and key pair inside the machine.

#### IMPORTANT

You cannot forward a received fax/I-fax document with a user signature from the machine.

#### NOTE

- This mode is available only if the optional Digital User Signature PDF Kit is activated.
- For information on the certificate authorities that you can use for issuing user certificates for each user, see the Before Using the Digital User Signature PDF Kit included with the Digital User Signature PDF Kit.
- The following conditions are necessary to add a user signature to a PDF:
  - A login service (SDL or SSO) must be set for the machine.
  - A user certificate must be installed in the machine using the Remote UI. (See Chapter 3, "Customizing Settings," in the *Remote UI Guide*.)

### 1 Log in to the machine using a login service.

For more information on the SDL and SSO login services, see Chapter 2, "Basic Operations," in the *Reference Guide*.

**2 Place your originals and specify the destination → press [File Format] → [Add Digital Signatures].**

If necessary, see the screen shot in step 2 of "Adding a Device Signature," on p. 5-35.

**3 Press [User Signature] → [OK] → [OK].**

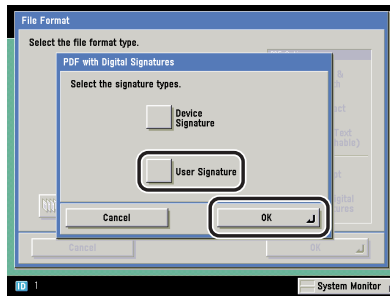



**4 Press  (Start).**

# Job Recall

You can recall the last three addresses, scan settings, and send settings which have been set, and then send your documents.

## IMPORTANT

- The machine considers any one of the following operations a send job:
  - When settings, such as the destination, scan settings, and send settings, are specified, and the control panel power switch,  (Start), or  (Reset) is pressed
  - When the Auto Clear mode activates after send settings are specified
- The Standard mode is not stored in Recall memory.
- Identical send settings are stored only once in Recall memory.
- If Access Number Management in Restrict the Send Function in System Settings (from Additional Functions screen) is set to 'On', the Recall mode cannot be used.
- If a destination type in Restrict New Addresses in Restrict the Send Function in System Settings (from the Additional Functions screen) is set to 'On', all stored settings in the Recall mode are erased, regardless of the destination type.

## NOTE

The three most recent settings that were stored in memory are not erased even when the main power is turned OFF.

---

## **1** Place your originals → press [Recall].

### NOTE

For instructions on placing your originals, see Chapter 2, "Basic Operation," in the *Reference Guide*.



## 2 Select [1 Before], [2 Before], or [3 Before] → confirm the settings → press [OK].

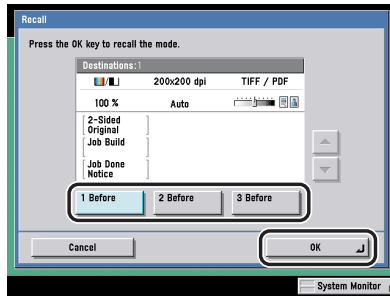

### IMPORTANT

- If the optional Super G3 Multi-Line Fax Board is installed, the unit name registered for the line that is selected for Priority TX in TX Line Selection in Dual Line Options under <Fax Settings> in Communications Settings (from the Additional Functions screen) is displayed. (See "Selecting the Line for Sending," on p. 9-52.)
- When [Auto] is selected for <Line Selection>, the user name displayed/printed on the recipient's machine will be the user name registered for the line which was used for sending.

### NOTE

- You can change the settings in a recalled send job.
- If there are multiple destinations stored in Recall memory, the order of the destinations shown in the list may not correspond to the order in which they were set.

## 3 Press (Start).

### NOTE

If [Preview] on the Send Settings screen is set, you can verify the images from the Preview screen before sending your document. (See "Previewing Originals," on p. 5-17.)



# 6

## CHAPTER

# Receiving Documents

This chapter describes the basic reception features. You can receive document transmissions automatically, forward received documents to a specified destination, or print a received document from memory.

---

Receiving Print, Fax, and I-Fax Documents . . . . .	6-2
Receiving Documents. . . . .	6-3
Processing Received Documents. . . . .	6-5
Setting the Memory Lock Mode . . . . .	6-7
Forwarding Received Documents. . . . .	6-7
Erasing Received Documents . . . . .	6-8
Available Paper Sizes . . . . .	6-10

# Receiving Print, Fax, and I-Fax Documents

## ■ Receiving Print Jobs

The machine receives and prints print jobs sent from a computer.

## ■ Receiving I-Fax Documents

The I-fax function is similar to e-mail. However, instead of sending and receiving messages over the Internet, I-fax enables you to send and receive scanned document images via the Internet.

You can set the machine to automatically forward received I-fax documents to specified destinations. For more information on specifying forwarding settings, see "Forwarding Settings," on p. 11-22.

### NOTE

- If files (images) that are attached to received I-fax documents are not compatible with this machine, the machine does not process (print, forward, or store) these files, but erases them instead. The names of the erased files and the message "Could not create image" are printed with the text of the received I-fax.
- If a received I-fax document does not contain an e-mail message, and contains only a TIFF file attachment, the sender's name and subject of the e-mail (each up to 24 characters) are printed as the header of the TIFF image.

## ■ Receiving Fax Documents

This machine's Super G3 fax function is compatible with most Super G3 fax machines used in office environments.

You can automatically forward received fax documents to specified destinations. For more information on specifying forwarding settings, see "Forwarding Settings," on p. 11-22.

### NOTE

- This mode is available only if the optional Super G3 FAX Board or Super G3 Multi-Line Fax Board is installed.

# Receiving Documents

- 1** When documents are being received, the Processing/Data indicator on the control panel flashes a green light.

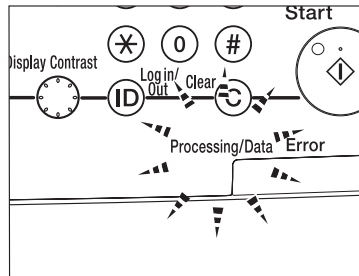

## NOTE

- During reception, the transaction number and information related to the sender are displayed on the touch panel display.

- 2** When document reception is complete, the Processing/Data indicator on the control panel maintains a steady green light. This indicates that documents are stored in memory.

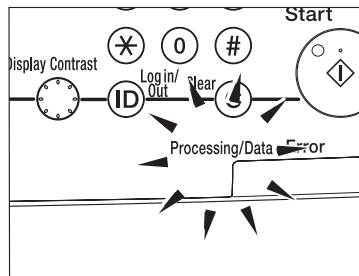

## NOTE

- The Processing/Data indicator flashes or maintains a steady green light even when the machine enters the Sleep mode.
- The Error indicator flashes a red light when either the amount of available memory is low or paper needs to be loaded into a paper drawer.

### 3 The document is printed.

The Processing/Data indicator goes out when documents stored in memory are printed.



#### NOTE

- If there is no paper on which the received documents can be printed, the received documents are stored in memory.
- The memory can hold a total of approximately 6,000 pages of sent and received documents.
- Documents which have been stored in memory because the paper has run out, are automatically printed when paper is loaded into a paper drawer.
- If a printing error occurs, the Error indicator flashes a red light.

# Processing Received Documents

When the Machine receives I-fax/Fax documents, they are processed as shown below:

Sender

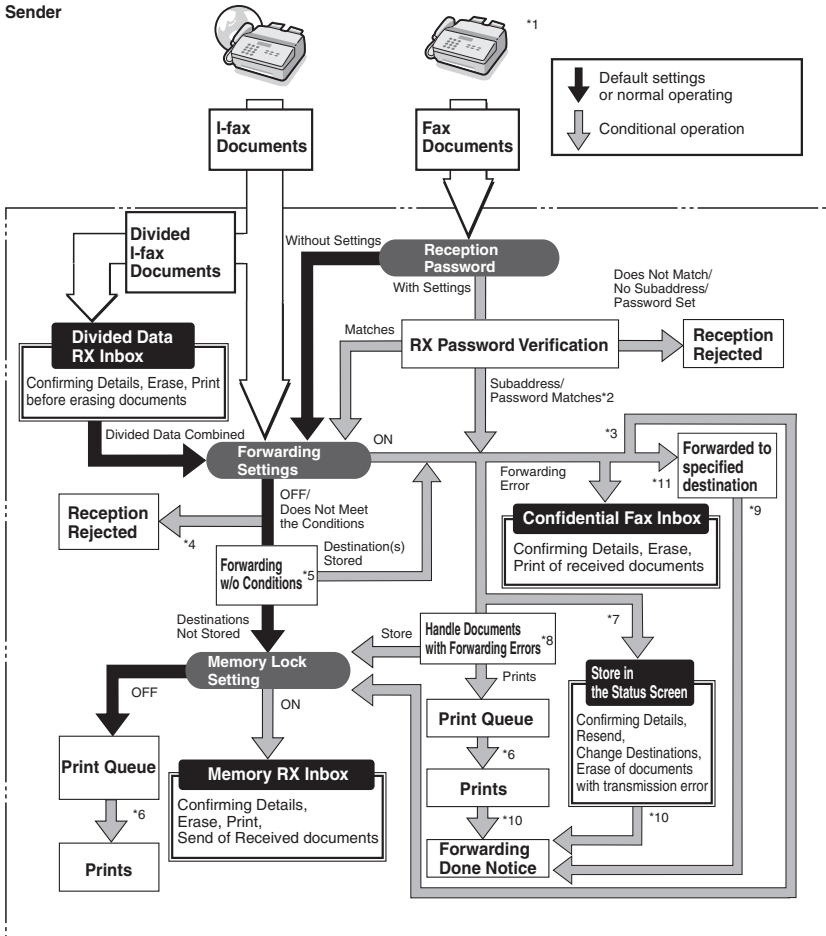

- \*1 Received fax documents can be forwarded if the optional Super G3 FAX Board or Super G3 Multi-Line Fax Board is installed.
- \*2 If the subaddress and password attached to the received document match the information registered in Forwarding Settings in System Settings (from the Additional Functions screen), the documents are forwarded to their forwarding destinations regardless of the reception password setting.
- \*3 If Store/Print Received Doc. in Forwarding Settings in System Settings (from the Additional Functions screen) is set to 'On', forwarded documents are either printed or stored in the Memory RX Inbox.
- \*4 If the subaddress and password attached to the received document do not match the information registered in Forwarding Settings in System Settings (from the Additional Functions screen), the document is rejected.
- \*5 If Forward w/o Conditions is set up in Forwarding Settings in System Settings (from the Additional Functions screen), all received documents that do not match the specified forwarding conditions are forwarded to the destination selected for Forward w/o Conditions.
- \*6 If documents are received while paper is jammed, or paper or toner has run out, it is printed after the paper jam is cleared, paper is loaded, or toner is added.
- \*7 If Erase Failed TX in TX Settings under <Common Settings> in Communications Settings (from the Additional Functions screen) is set to 'Off', the status of any job with a forwarding error will be saved on the System Monitor screen.
- \*8 Documents with forwarding errors are handled as follows, depending on the settings for Handle Documents with Forwarding Errors in TX Settings under <Common Settings> in Communications Settings (from the Additional Functions screen):
  - [Always Print]: All documents with forwarding errors are printed.
  - [Store/Print]: Documents with forwarding errors are stored in the Memory RX Inbox when Memory Lock is turned 'On'. If Memory Lock is turned 'Off', the documents are printed.
- \*9 If the Forwarding Done Notice is specified in Forwarding Settings in System Settings (from the Additional Functions screen), a notification e-mail is sent when the forwarding job completes successfully.
- \*10 If the Forwarding Done Notice is specified in Forwarding Settings in System Settings (from the Additional Functions screen), a notification e-mail is sent when the forwarding job completes successfully. However, if <Notice Only for Errors> is also specified, a notification e-mail is sent only when the document fails to be forwarded.
- \*11 The received Fax/I-fax documents can be stored in the Confidential Fax Inbox by specifying the Confidential Fax Inbox as forwarding destination. Only the received documents that match the specified forwarding conditions can be stored in the Confidential Fax Inbox.

 NOTE

- If the memory is full, no additional jobs can be processed.
- For information on the following settings, see their respective sections:
  - Memory RX Inbox, Fax Memory Lock, and I-Fax Memory Lock (See "Storing Received Fax Documents in Memory," on p. 11-10, or "Storing Received I-Fax Documents in Memory," on p. 11-11.)
  - Confidential Fax Inbox and Forwarding Settings (See "Forwarding Settings," on p. 11-22.)



## Setting the Memory Lock Mode

You can set to store the received fax/I-fax documents in the Memory RX Inbox without printing them. After verifying the documents on the Memory RX Inbox screen, you can print or send them whenever necessary.

If you set Use Fax Memory Lock or Use I-Fax Memory Lock mode to 'On', you can turn Fax Memory Lock or I-Fax Memory Lock for documents sent to the Memory RX Inbox 'On' or 'Off' as necessary. If Fax Memory Lock or I-Fax Memory Lock mode is set to 'On', received documents are stored in the Memory RX Inbox instead of being printed. (See Chapter 6, "Sending and Receiving Documents Using the Inboxes," in the *Copying and Mail Box Guide*.)



### IMPORTANT

- Additional documents cannot be stored in the Memory RX Inbox under the following conditions. (These numbers may vary depending on the remaining capacity of the hard disk.)
  - When 1,500 documents have been stored in any or all of the inboxes
  - When 6,000 pages have been stored in any or all of the inboxes



### NOTE

- To receive documents in memory, you must first set Use Fax Memory Lock or Use I-Fax Memory Lock in Memory RX Inbox Settings in Communications Settings in System Settings (from the Additional Functions screen) to 'On'. (See "Storing Received Fax Documents in Memory," on p. 11-10, or "Storing Received I-Fax Documents in Memory," on p. 11-11.)

## Forwarding Received Documents

If you receive a fax/I-fax document, and it conforms to the specified forwarding conditions, the document is automatically forwarded to the specified destination. You can register the forwarding conditions and destinations in Forwarding Settings in System Settings (from the Additional Functions screen). (See "Forwarding Settings," on p. 11-22.)



### NOTE

- To be able to forward received documents, you must first set Validate/Invalidate to 'On' in Forwarding Settings in System Settings (from the Additional Functions screen). (See "Forwarding Settings," on p. 11-22.)

# Erasing Received Documents

You can erase any received document stored in the Memory RX Inbox or the Confidential Fax Inboxes. If the memory is full, the machine cannot receive any more documents. It is recommended that you erase unnecessary documents as often as possible.

## NOTE

- Additional documents cannot be stored in the Memory RX Inbox or the Confidential Fax Inbox under the following conditions. (These numbers may vary depending on the remaining capacity of the hard disk.)
  - When 1,500 documents have been stored in any or all of the inboxes
  - When 6,000 pages have been stored in any or all of the inboxes

## 1 Press [Mail Box] → select [Memory RX Inbox] or [Conf. Fax Inbox].

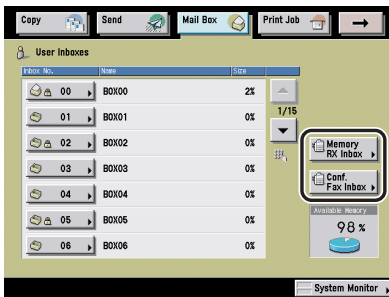

Details of each item are shown below.

[Memory RX Inbox]: To select a received document that has been stored in the Memory RX Inbox.

[Conf. Fax Inbox]: To select a received document that has been forwarded to a Confidential Fax Inbox.

## 2 Select the desired inbox and the document that you want to erase → press [Erase].

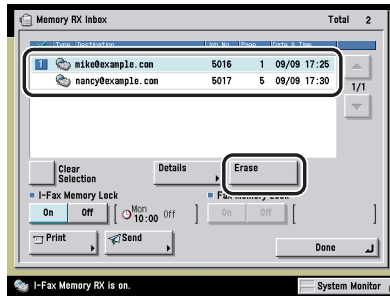



In the example above, Memory RX Inbox is specified.

Memory RX Inbox contains only one inbox.

To erase multiple documents in the memory RX Inbox or a Confidential Fax Inbox, select and erase one document at a time.

### NOTE

- You can cancel a selection by selecting the document again.
- If the document is stored in an inbox, that inbox is displayed with the (  ) icon.
- If an inbox is set with a password, a locked mark (  ) is displayed next to the icon of that inbox.
- If you make a mistake when selecting an inbox, press [Done] → select the correct inbox.

## 3 Press [Yes].

## 4 Press [Done].

## 5 Press [Send].

# Available Paper Sizes

When received documents are printed, they are printed from the paper drawer that has the same paper size as the received document. If paper of the correct size is not available, the machine automatically selects a different paper size in the following order. (If all the switches in Select Drawer in RX Setting under <Common Settings> in Communications Settings (from the Additional Functions screen) are set to 'On'). The paper size is automatically selected in the same order, even if paper runs out during printing.

## ■ Available Paper Sizes for Received Documents

11" x 17" originals	11" x 17" → LGL*1 → STMT x 2
LGL originals	LGL → LTR x 2 → STMT x 2 → 11" x 17"
LTR originals	LTR → LGL → STMT x 2 → 11" x 17"
STMT originals	STMT → LTR → LGL → 11" x 17"

\*1 Received documents are automatically reduced before being printed on the paper size indicated.

### IMPORTANT

- Received documents can be printed on the following paper sizes and paper types:  
Paper Sizes: 11" x 17", LGL, LTR, LTRR, or STMT  
Paper Types: plain, recycled, or color

### NOTE

- You can specify each paper drawer for the fax/I-fax function. The default setting is 'On', except for the stack bypass. (See Chapter 4, "Customizing Settings," in the *Reference Guide*.)
- You can set the machine to reduce received documents from 75% to 97% in 1% increments if the document is larger than any of the available paper sizes. (See "Reducing a Received Document," on p. 9-37.)
- You can change the order of paper selection. (See "Paper Drawer Selection," on p. 9-35.)
- You can set the machine to print received documents on both sides of the paper. (See "2-Sided Printing," on p. 9-34.)
- Received documents are output face down, in the order in which the pages are received.

# 7

## CHAPTER

# Special Fax Functions

This chapter describes special fax sending and receiving features.

---

Sending with a Subaddress . . . . .	7-2
Using a PIN Code . . . . .	7-5
Setting PIN Code Access . . . . .	7-5
Dialing with a PIN Code . . . . .	7-6
Fax Information Services . . . . .	7-8

# Sending with a Subaddress

If the destination fax machine is compatible with ITU-T (International Telecommunications Union-Telecommunications Sector) standard subaddress and passwords, you can send or receive documents with increased security by attaching a subaddress and a password to all of your fax transactions.

## NOTE

- This mode is available only if the optional Super G3 FAX Board or Super G3 Multi-Line Fax Board is installed.

**1** Place your originals → press [New Address] → [Fax] → enter the fax number.

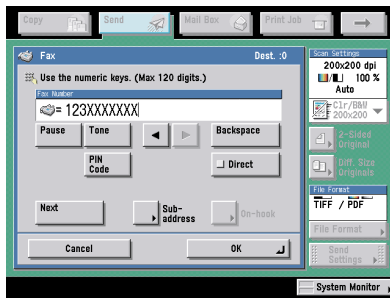

Details of each item are shown below.

- [Pause]: Press to insert a pause of several seconds in the fax number that you are dialing. If you insert a pause, the letter <p> is displayed between the numbers, and the letter <P> appears at the end of the number. When dialing an overseas number, insert a pause after the country code, and at the end of the telephone number. (See "Pause Time," on p. 9-44.)
- [Tone]: Press when you want to directly call an extension line that is connected to a PBX (Private Branch Exchange) which accepts only tone signals. (See "Fax Information Services," on p. 7-8.)
- [◀] [▶]: Press to move the position of the cursor.
- [Backspace]: Press when an incorrect number is entered. The last number entered is deleted, enabling you to enter the correct number.
- [PIN Code]: Press to enter the PIN (Personal Identification Number) code. You can press this key only if [Option] is selected for PIN code position. If [Prefix], [Suffix], or [Off] is selected for PIN code position, this key is grayed out. (See "Using a PIN Code," on p. 7-5.)
- [Direct]: Press to send documents directly to the recipient. If you do not select Direct Sending mode, Memory Sending mode is used. (See "Sending a Fax," on p. 5-2.)
- [Next]: Press to specify another destination after specifying the first destination using ① - ⑨ (numeric keys).
- [Option]: Displayed if the optional Super G3 Multi-Line Fax Board is installed. Press to set the subaddress and password, or to select the line type of the additional line.
- [Subaddress]: Press to set up an optional subaddress and password.
- [On-hook]: Press to use tone dialing. (See "Fax Information Services," on p. 7-8.)



#### IMPORTANT

You cannot insert a pause at the beginning of a number.



#### NOTE

- For instructions on placing your originals, see Chapter 2, "Basic Operations," in the *Reference Guide*.
- If you enter a pause at the end of the number, the pause is always 10 seconds long.

## 2 Press [Subaddress].

If the Optional Super G3 Multi-Line Fax Board is installed, press [Option].

## 3 Press [Subaddress] or [Password] → enter the subaddress and password using 0 - 9 (numeric keys), \*, and # → press [OK].

If the recipient did not set a password for the target subaddress, you do not need to enter a password.

Press [Space] to insert a space.

Press [Backspace] to delete the last digit that you entered.

## 4 Press (Start).



### NOTE

If [Preview] on the Send Settings screen is set, you can verify the images from the Preview screen before sending your document. (See "Previewing Originals," on p. 5-17.)



# Using a PIN Code

The PIN (Personal Identification Number) code prevents unauthorized personnel from making calls. To protect privileged access to the telephone lines, only authorized users are entrusted with the PIN codes for daily operations. Some PBX (Private Branch eXchange) systems require that a PIN code be entered when dialing a number to make a call or send a document by fax. Depending on the requirements of the PBX system, the PIN code may be entered either before the number as a prefix, or after the number as a suffix.

## NOTE

This mode is available only if the optional Super G3 FAX Board or Super G3 Multi-Line Fax Board is installed.

## Setting PIN Code Access

If your PBX requires a PIN Code to get an outside line, your machine can be set to prompt the user to enter the PIN Code before dialing.

- 1** Press  (Additional Functions) → [System Settings] → [Communications Settings] → [Fax Settings].
- 2** Press [PIN Code Access].

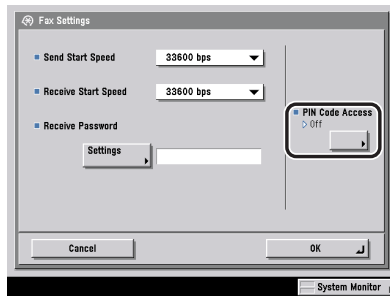

- 3** Press [On] → select the desired type of PIN code → [OK].

If you do not want to set the PIN Code, press [Off] → [OK] → [OK].

Details of each item are shown below.

[Option]: If your PBX requires a PIN Code depending on the destination, select [Option]. If PIN Code Access is set to 'Option', the PIN Code key is enabled on the Fax screen.

[Prefix]: If your PBX always requires a PIN Code before the destination, select [Prefix].

[Suffix]: If your PBX always requires a PIN Code after the destination, select [Suffix].

## Dialing with a PIN Code

This section describes the procedure for dialing fax numbers with a PIN code.

### NOTE

- If PIN Code Access is set to 'On', the machine automatically displays a screen prompting you to enter the PIN Code when you press  (Start).
- The position to enter PIN codes depends on the type of PBX system you are using.

---

**1 Place your originals → make sure the machine is ready to send → press [New Address] → [Fax].**

**2 Enter the fax number with a PIN code according to PIN code position set for your machine → press [OK].**

### NOTE

If PIN Code Position is set to [Option], PIN codes are not displayed when you are entering the fax number, for increased security (only <C> appears). PIN codes also do not appear in printed activity reports.

● If you select [Option]:

- Enter the fax number using 0 - 9 (numeric keys), \*, and # → press [PIN Code] when you reach the desired PIN code position → continue entering the rest of the fax number.

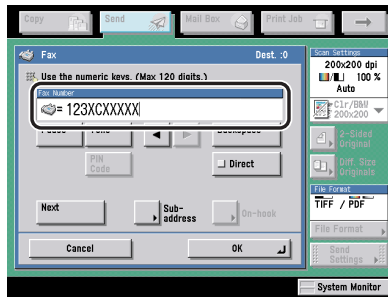

[PIN Code] can be pressed either before the fax number, after the fax number, or while specifying the fax number.

<C> is displayed on the screen after you press [PIN Code].

● If you select [Prefix] or [Suffix]:

- Enter the fax number using 0 - 9 (numeric keys), \*, and #.

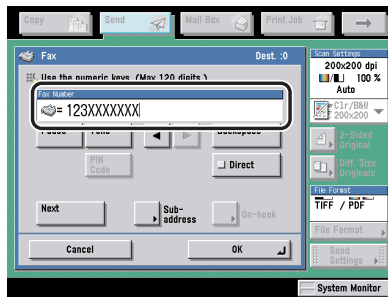

**3** Press 0 (Start) → enter the PIN code using 0 - 9 (numeric keys) → press [OK].



**NOTE**

The PIN code that you have entered appears as asterisks on the Pin Code screen.

# Fax Information Services

Many fax information services for banks, airline reservations, hotel reservations, etc., require tone dialing for their services. If your machine is connected to a rotary pulse telephone line, follow the procedure below to temporarily set the machine for tone dialing.

## IMPORTANT

Make sure that you hear the dial tone before entering the fax number. If you enter the fax number before hearing the dial tone, the call may not be connected, or an incorrect number may be dialed.

## NOTE

- This mode is available only if the optional Super G3 FAX Board or Super G3 Multi-Line Fax Board is installed.
- When you use fax information services, you cannot specify a destination that is stored in the Address Book or use the Job Recall mode.

**1** Press [New Address] → [Fax].

**2** Press [On-hook] → enter the number of the fax information service using **0** - **9** (numeric keys).

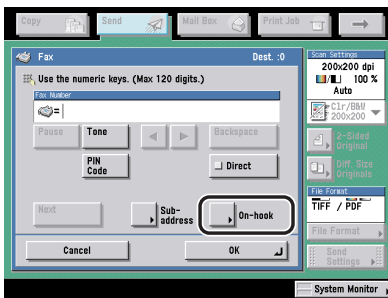

## IMPORTANT

If the optional Card Reader-C1 is attached, the line will be disconnected if you press [On-hook], and then remove the control card while the line is engaged.

● **If you press [One-touch Buttons]:**

- ❑ Select the desired one-touch button → press [OK].

One-touch buttons are assigned a three digit number. To specify a destination using a one-touch button's three digit number, enter the three digit number using 0 - 9 (numeric keys).

- ❑ Press [OK].



**NOTE**

For more information on one-touch buttons, see "Using the One-Touch Buttons," on p. 2-25.

**3 When your call is answered and you hear the recorded message of the fax information service, press [Tone].**

If you are already using this machine with tone dialing, this step is not necessary. The volume of the dial tone can be adjusted by pressing [V] or [V].

**4 Enter the numbers requested by the fax information service using 0 - 9 (numeric keys), \*, and #.**



**NOTE**

If you require more information about the service, contact the company providing the service.

**5 Press [RX Start] if you require a faxed copy of the information.**

If you do not require a faxed copy of the information, press [End].



# Checking/Changing the Send/ Receive Status

# 8

## CHAPTER

This chapter describes how you can check/change the status of send and receive jobs.

---

Checking/Changing the Status of Send Jobs . . . . .	8-2
Checking Send Job Details . . . . .	8-2
Changing the Destination . . . . .	8-5
Resending a Job. . . . .	8-7
Printing the Send Job Status/Log. . . . .	8-8
Checking/Changing the Status of Fax Jobs . . . . .	8-9
Checking Fax Job Details . . . . .	8-9
Printing the Fax Activity Report . . . . .	8-11
Checking/Changing the Status of Receive and Forwarded Jobs . . . . .	8-12
Checking Receive Job Details . . . . .	8-12
Printing the Receive Job Log . . . . .	8-13
Checking the Arrival of a Receive Job . . . . .	8-13
Checking the Status of Jobs That Have Been Forwarded . . . . .	8-14

# Checking/Changing the Status of Send Jobs

This section describes how to check/change the status of send jobs. For more information, see Chapter 5, "Checking Job and Device Status," in the *Reference Guide*.

## NOTE

- If Job Log Display in System Settings (from the Additional Functions screen) is set to 'Off', [Log] is not displayed on the System Monitor screen.
- Send jobs to e-mail, I-fax, and file servers can be checked/changed.
- If the optional Super G3 FAX Board or Super G3 Multi-Line Fax Board is installed, fax jobs in addition to the above mentioned jobs can be checked/changed.
- The maximum number of send jobs that are displayed on the Send Status screen is 120.
- The maximum number of send and receive jobs that are displayed on the Send Log screen is 100.

## Checking Send Job Details

You can check detailed information of any send job, such as the destination and the date and time the job was specified.

### 1 Press [System Monitor].

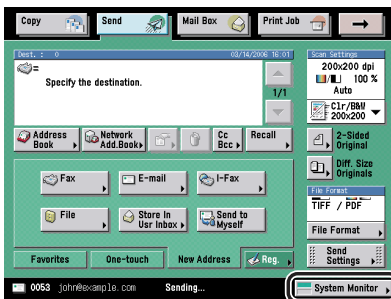



## 2 Press [Send] → [Status] or [Log].

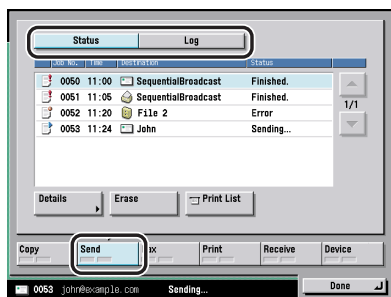

## 3 Select a job whose detailed information you want to check → press [Details].



### IMPORTANT

You cannot check the status of fax jobs sent with the Direct Sending or Manual Sending mode, or sent from computers via the fax driver because the statuses of those jobs are not displayed. To check their statuses, see the Send Job Status screen for Fax.



### NOTE

- If Erase Failed TX in TX Settings under <Common Settings> in Communications Settings (from the Additional Functions screen) is set to 'Off' when multiple destinations are selected for a send job, <Finished.> is displayed for those destinations to which the job was sent successfully, and <Error> is displayed for those destinations that had transmission errors. When multiple destinations are simultaneously specified for a send job, and you select and cancel the transmission to any one of those destinations, or the retransmission of an error job or an interrupted job is completed successfully, information on all of those simultaneously specified destinations is displayed in the log.
- If you send documents using the Full mode to a machine that does not support the Full mode, delivery confirmation cannot be carried out. In this case, the job concerned is not considered as complete even though the actual sending of the document is successful. Such jobs are displayed as <Waiting for result...> on the Status screen until the time set for <Full Mode TX Timeout> in E-mail/I-Fax Settings in Communications Settings in System Settings (from the Additional Functions screen) has lapsed. After the timeout, the job is moved to the log, and the result is shown as <-> when sending of the document to a server or other destination could not be verified.

**● If you select a job with only one destination in [Status]:**

- Check the details.

To change the destination, press [Change Destination]. (See "Changing the Destination," on p. 8-5.)

To resend the job, press [Resend]. (See "Resending a Job," on p. 8-7.)

**● If you select a job with multiple destinations in [Status]:**

- Check the details.
- Press [Broadcast List].
- Check the status for each destination.

To change the destination, press [Change Destination]. (See "Changing the Destination," on p. 8-5.)

To resend the job, press [Resend]. (See "Resending a Job," on p. 8-7.)

**● If you select a job in [Log]:**

- Check the details.

# Changing the Destination

You can change the destination of a send job from the System Monitor screen.



## IMPORTANT

- You can only change the destination for send jobs that have been canceled due to a transmission error or jobs that have been set with the Delayed Send mode and are still waiting in the send queue.
- To be able to change the destination for send jobs that have been canceled due to a transmission error, you must first set Erase Failed TX in TX Settings under <Common Settings> in Communications Settings (from the Additional Functions screen) to 'Off'. (See "Automatic Document Deletion," on p. 9-10.)
- You cannot change more than one destination at the same time. You also cannot change the destination of a whole group at once.
- You cannot change the destination of a send job if another job with the same job number is being sent or is waiting in the send queue. This restriction does not apply to Delayed Send jobs.
- If the total number of destinations, including the destinations specified by the Address Book and one-touch buttons that have been changed, and new destinations or destinations specified by a server, has reached 64, you can no longer change the destinations that have been specified by the Address Book or one-touch buttons.
- You cannot change the destinations of fax jobs sent with the Direct Sending or Manual Sending mode, or sent from computers via the fax driver because the statuses of those jobs are not displayed.
- If a destination type in Restrict New Addresses in Restrict the Send Function in System Settings (from the Additional Functions screen) is set to 'On', you cannot change the destination, regardless of the destination type.



## NOTE

- You cannot change the destination type. For example, you cannot change the destination of a job from an e-mail address to an I-fax address. Also, you cannot change the destination of a job from a fax number to a User Inbox.
- If a job is specified to be stored in a User Inbox, you cannot change the inbox in which to store the job.

---

## 1 Press [System Monitor].

If necessary, see the screen shot in step 1 of "Checking Send Job Details," on p. 8-2.

## 2 Press [Send] → [Status].

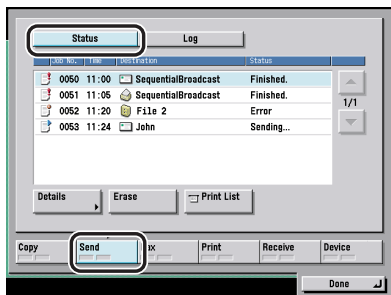

## 3 Select the job whose destination you want to change → press [Details].

## 4 Select the destination that you want to change.

### ● If there is only one destination:

- Press [Change Destination].

### ● If there are multiple destinations:

- Press [Broadcast List].
- Select the destination that you want to change → press [Change Destination].

## 5 Change the destination.

The types of destinations and the settings that you can change are:

- E-mail: E-mail Address
- I-Fax: I-Fax Address, Mode, Send Via Server (On/Off)
- File: Host Name, File Path, User, Password
- Fax: Fax Number (If the optional Super G3 FAX Board or Super G3 Multi-Line Fax Board is installed.)

## 6 Press [OK].

# Resending a Job

You can resend jobs that are canceled due to transmission errors.



## IMPORTANT

- To be able to resend jobs that have been canceled due to a transmission error, you must first set Erase Failed TX in TX Settings under <Common Settings> in Communications Settings (from the Additional Functions screen) to 'Off'. (See "Automatic Document Deletion," on p. 9-10.)
- You cannot resend fax jobs sent with the Direct Sending or Manual Sending mode, or sent from computers via the fax driver because the statuses of those jobs are not displayed.

## 1 Press [System Monitor] → [Send] → [Status].

If necessary, see the screen shots in step 1 and step 2 of "Changing the Destination," on p. 8-5.

## 2 Select the job that you want to resend → press [Details].

## 3 Select the destination to resend the job to.

### ● If there is only one destination:

- Press [Resend].

### ● If there are multiple destinations for the same sending method:

- Press [Broadcast List].
- Select the destination to resend the job to → press [Resend].



## NOTE

The job is placed in the send queue if there is another job being sent or waiting to be processed.

# Printing the Send Job Status/Log

## 1 Press [System Monitor] → [Send] → select [Status] or [Log].

If necessary, see the screen shots in step 1 and step 2 of "Changing the Destination," on p. 8-5.

Details of each item are shown below.

[Status]: Press this key if you want to print the send job list (Send Job List).

[Log]: Press this key if you want to print the send job log (Activity Report).

## 2 Press [Print List].





### IMPORTANT

You cannot print the Send Job List for fax jobs sent with the Direct Sending or Manual Sending mode, or sent from computers via the fax driver because the statuses of those jobs are not displayed.



### NOTE

- The icons that are displayed on the left side of the list are explained below:
  - : A job for which an Activity Report has already been printed
  - : A job for which an Activity Report has not yet been printed
- The send job status/log can be printed only if 11" x 17", LGL, LTR, or LTRR (plain, recycled, or color paper) is loaded in the paper sources whose settings in Other in Drawer Eligibility For APS/ADS in Common Settings (from the Additional Functions screen) are set to 'On'. (See Chapter 4, "Customizing Settings," in the *Reference Guide*.)

## 3 Press [Yes].

# Checking/Changing the Status of Fax Jobs

This section describes how to check/change the status of fax jobs. For more information, see Chapter 5, "Checking Job and Device Status," in the *Reference Guide*.

## NOTE

- If Job Log Display in System Settings (from the Additional Functions screen) is set to 'Off', [Log] is not displayed on the System Monitor screen.
- This mode is available only if the optional Super G3 FAX Board or Super G3 Multi-Line Fax Board is installed.
- The maximum number of jobs that are displayed is:
  - Send Job Status screen: 64 jobs
  - Received Job Status screen: 1 job (The optional Super G3 FAX Board is installed.)  
2 jobs (The optional Super G3 Multi-Line Fax Board is installed.)
  - Log screen: 100 jobs

## Checking Fax Job Details

You can check the detailed information of any fax job, such as the destination and the date and time the job was specified.

### **1** Press [System Monitor].

If necessary, see the screen shot in step 1 of "Checking Send Job Details," on p. 8-2.

## 2 Press [Fax] → [Send Job Status], [Received Job Status], or [Log].

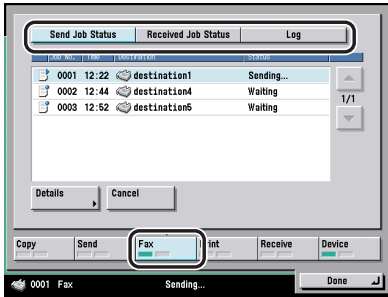

### ● If you select [Send Job Status]:

- Select the job whose detailed information you want to check → press [Details].

### ● If you select [Received Job Status]:

- Press [Details].

### NOTE

If the optional Super G3 Multi-Line Fax Board is installed, you can select between two received fax jobs to check.

### ● If you select [Log]:

- Select the job whose detailed information you want to check → press [Details].

## 3 Check the details of the selected job.

If you selected a job with multiple destinations in [Send Job Status], press [Broadcast List] → check the status of each destinations → press [Done].



# Printing the Fax Activity Report

You can print the Fax Activity Report, which includes the fax transmission's start time, destination, job number, transmission mode, number of pages, and transmission result.

## 1 Press [System Monitor].

If necessary, see the screen shot in step 1 of "Checking Send Job Details," on p. 8-2.

## 2 Press [Fax] → [Log].

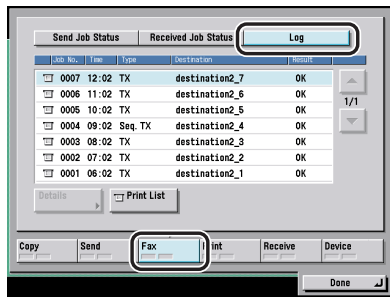

## 3 Press [Print List].

### NOTE

- The icons that are displayed on the left side of the list are explained below:
  - : A job for which a Fax Activity Report has already been printed
  - : A job for which a Fax Activity Report has not yet been printed
- The Fax Activity Report can be printed only if 11" x 17", LGL, LTR, or LTRR (plain, recycled, or color paper) is loaded in the paper sources whose settings in Other in Drawer Eligibility For APS/ADS in Common Settings (from the Additional Functions screen) are set to 'On'. (See Chapter 4, "Customizing Settings," in the *Reference Guide*.)

## 4 Press [Yes].

# Checking/Changing the Status of Receive and Forwarded Jobs

You can check the details of received documents stored in memory, as well as the status of forwarded jobs and receive jobs.

## NOTE

- If Job Log Display in System Settings (from the Additional Functions screen) is set to 'Off', <Activity Report (RX)>, [Details], and [Print List] on the Receive screen are not displayed on the System Monitor screen.
- Up to 100 documents for the total of send and receive jobs combined can be displayed on the job log (Activity Report (RX)) screen.

## Checking Receive Job Details

You can check the detailed information of any received job, such as the destination and the date and time the job was received.

### 1 Press [System Monitor].

If necessary, see the screen shot in step 1 of "Checking Send Job Details," on p. 8-2.

### 2 Press [Receive] → select a job whose detailed information you want to check → press [Details].

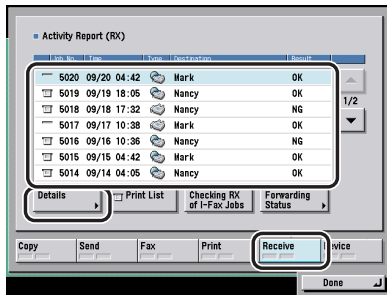

### 3 Check the details of the selected job.

## Printing the Receive Job Log

You can print the receive job log (Activity Report (RX)).



### 1 Press [System Monitor].

If necessary, see the screen shot in step 1 of "Checking Send Job Details," on p. 8-2.

### 2 Press [Receive] → [Print List].



#### NOTE

- The icons that are displayed on the left side of the list are explained below:
  - : A job for which an Activity Report has already been printed
  - : A job for which an Activity Report has not yet been printed
- The receive job log can be printed only if 11" x 17", LGL, LTR, or LTRR (plain, recycled, or color paper) is loaded in the paper sources whose settings in Other in Drawer Eligibility For APS/ADS in Common Settings (from the Additional Functions screen) are set to 'On'. (See Chapter 4, "Customizing Settings," in the *Reference Guide*.)

### 3 Press [Yes].

## Checking the Arrival of a Receive Job

The machine regularly checks for the arrival of an I-fax. However, you can check for the arrival of an I-fax at any time by performing the procedure below.

### 1 Press [System Monitor].

If necessary, see the screen shot in step 1 of "Checking Send Job Details," on p. 8-2.

## 2 Press [Receive] → [Checking RX of I-Fax Jobs].

The screen below is displayed while the machine is checking for the arrival of an I-fax.

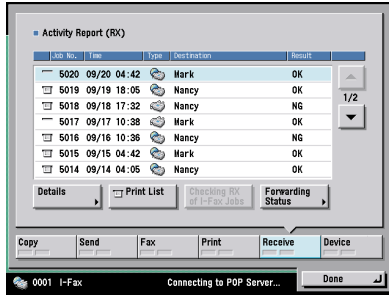

### NOTE

To be able to use [Checking RX of I-Fax Jobs], you must first set the POP setting in E-mail/I-Fax in Network Settings in System Settings (from the Additional Functions screen) to 'On' so that you can receive documents using POP. (See Chapter 3, "Using a TCP/IP Network," in the *Network Guide*.)

## Checking the Status of Jobs That Have Been Forwarded

You can check the details of jobs that have been forwarded, depending on the forwarding settings.

### 1 Press [System Monitor].

If necessary, see the screen shot in step 1 of "Checking Send Job Details," on p. 8-2.

### 2 Press [Receive] → [Forwarding Status].

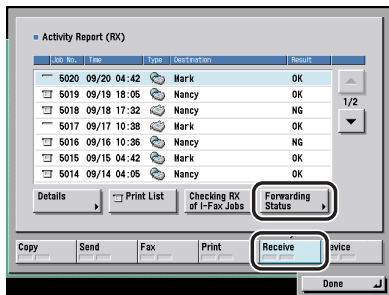

**3** Select a job whose detailed information you want to check → press [Details].



**NOTE**

If 120 send jobs have accumulated on the job status screen, jobs that are waiting to be forwarded are displayed on the Forwarding Status screen.

**4** Check the details of the selected job.



# Customizing Communications Settings

# 9

## CHAPTER

This chapter describes how to store and change the default settings of the Send/Receive function to suit your needs.

---

What are Additional Functions? .....	9-3
Communications Settings Table .....	9-6
Automatic Document Deletion .....	9-10
Data Compression Ratio for Color Send Jobs .....	9-11
Handling Documents That Fail to Be Forwarded .....	9-12
Number of Retry Attempts .....	9-13
Standard Send Settings .....	9-14
Favorites Buttons .....	9-16
Registering a Favorites Button .....	9-16
Naming a Favorites Button .....	9-17
Registering a Comment for a Favorites Button .....	9-18
Erasing a Favorites Button .....	9-19
Displaying Confirmation for Favorites Buttons .....	9-20
PDF Compression Priority .....	9-21
PDF (OCR) Mode .....	9-23
Confirming the Device Signature Certificate .....	9-25
Checking a User Signature Certificate .....	9-26
Initial Send Screen Display .....	9-27
Printing the TX Terminal ID .....	9-28
Dividing Data Into Chunks When Sending With WebDAV .....	9-31
Gamma Value for YCbCr Send Jobs .....	9-32
Initializing TX Settings .....	9-33
2-Sided Printing .....	9-34
Paper Drawer Selection .....	9-35
Reducing a Received Document .....	9-37

---

## 9. Customizing Communications Settings

---

Printing Footer Information on a Received Document . . . . .	9-39
2 On 1 Log . . . . .	9-40
Gamma Value for YCbCr Received Jobs . . . . .	9-41
Adjusting the Alarm and Monitor Volume . . . . .	9-42
ECM Transmission . . . . .	9-43
Pause Time. . . . .	9-44
Auto Redial . . . . .	9-45
Checking the Dial Tone before Sending . . . . .	9-47
ECM Reception. . . . .	9-48
Registering the Fax Number for an Additional Line . . . . .	9-49
Registering the Unit Name for an Additional Line. . . . .	9-50
Selecting the Telephone Line Type for an Additional Line . . . . .	9-51
Selecting the Line for Sending . . . . .	9-52



# What are Additional Functions?

Additional Functions enable you to customize the machine's various settings.

## NOTE



Settings specified from the Additional Functions screen are not changed when you press  (Reset).

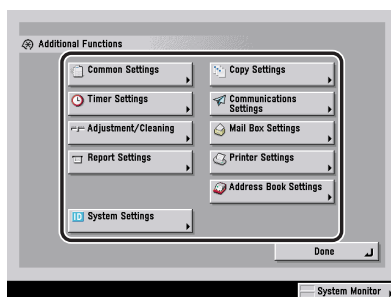

## 1 Press (Additional Functions).

The Additional Functions screen is displayed.

## 2 Select an Additional Functions setting.



If you select [System Settings] and the System Manager ID and System Password have been set, press [System Settings] → enter the System Manager ID and System Password using  -  (numeric keys) → press .

If a password has been set for the Address Book in Restrict the Send Function in System Settings, press [Address Book Settings] → enter the password using  -  (numeric keys) → press [OK]. (See "Address Book Password," on p. 11-15.)

### 3 Press a mode key to specify its settings.

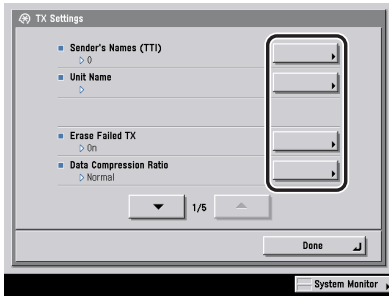

For more information on the settings you can specify by pressing the keys on the Additional Functions screen, see "Communications Settings Table," on p. 9-6, "Address Book Settings Table," on p. 10-2, "System Settings Table," on p. 11-2, and "Report Settings Table," on p. 12-2.

#### NOTE

Some screens are divided into several screens, press [▼] or [▲] to scroll through the lists.

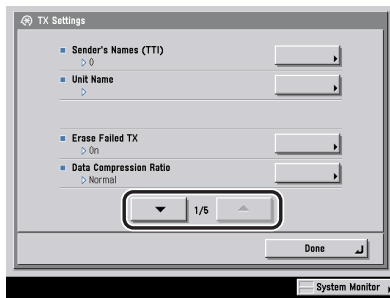

### 4 Specify the desired mode → press [OK].

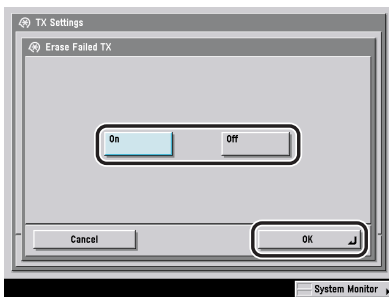

The selected mode is set.

- 5 Press [Done] repeatedly until the Send Basic Features screen appears.

# Communications Settings Table

The following items can be stored or set in Communications Settings from the Additional Functions screen.

## ■ Common Settings

Item	Settings	Delivered	Applicable Page
<b>TX Settings</b>			
Sender's Names (TTI) <sup>2</sup>	01 to 99: Register/Edit, Erase	No	p. 1-17
Unit Name	24 characters maximum	No	p. 1-18
Erase Failed TX	On <sup>1</sup> , Off	Yes	p. 9-10
Data Compression Ratio	High Ratio, Normal <sup>1</sup> , Low Ratio	Yes	p. 9-11
Handle Documents with Forwarding Errors	Always Print, Store/Print, Off <sup>1</sup>	Yes	p. 9-12
Retry Times	0 to 5 times; 3 times <sup>1</sup>	Yes	p. 9-13
Edit Standard Send Settings	Scanning Mode: Clr/B&W 200x200 dpi <sup>1</sup> File Format: TIFF/PDF Auto Select <sup>1</sup> Stamp: Off <sup>1</sup>	No	p. 9-14
Register Favorites Button	Register/Edit, Erase: M1 to M18 Display Comment: On, Off <sup>1</sup>	Yes	p. 9-16
Display Confirmation for Favorites Button	On <sup>1</sup> , Off	No	p. 9-20
Image Level for PDF (Compct) <sup>3</sup>	Image Level in Text/Photo Mode or Photo Mode: Data Size Priority, Normal <sup>1</sup> , Image Priority Image Level in Text Mode: Data Size Priority, Normal <sup>1</sup> , Image Priority	Yes	p. 9-21
PDF (OCR) Settings <sup>3</sup>	Smart Scan: On <sup>1</sup> , Off Number of Characters for Document Name Setting: 1 to 24 characters; 24 characters <sup>1</sup>	Yes	p. 9-23
Check Device Signature Certificate <sup>4</sup>	Certificate Details: Certificate Verification	No	p. 9-25
Check User Signature Certificate <sup>5</sup>	Certificate Details: Certificate Verification	No	p. 9-26

Item	Settings	Delivered	Applicable Page
Default Screen for Send	Favorites Buttons, One-touch Buttons, New Address <sup>*1</sup>	No	p. 9-27
TX Terminal ID	On <sup>*1</sup> ; If the optional Super G3 FAX Board or Super G3 Multi-Line Fax Board is installed:  TX Terminal ID: On Printing Position: Outside Display Destination Name: On Telephone # Mark: FAX  Off	Yes	p. 9-28
Use Chunked Encoding with WebDAV Sending	On <sup>*</sup> , Off	Yes	p. 9-31
Gamma Value for YCbCr Send Jobs	Gamma 1.0, Gamma 1.4, Gamma 1.8 <sup>*1</sup> , Gamma 2.2	Yes	p. 9-32
Initialize TX Settings	Initialize	No	p. 9-33
<b>RX Settings</b>			
2-Sided Print	On, Off <sup>*1</sup>	Yes	p. 9-34
Select Drawer	Switch A: On <sup>*1</sup> , Off Switch B: On <sup>*1</sup> , Off Switch C: On <sup>*1</sup> , Off Switch D: On <sup>*1</sup> , Off	Yes	p. 9-35
Receive Reduction	On <sup>*1</sup> ;  RX Reduction: Auto Reduce %: 90% Reduce Direction: Vertical Only  Off	Yes	p. 9-37
Received Page Footer	On, Off <sup>*1</sup>	Yes	p. 9-39
2 On 1 Log	On, Off <sup>*1</sup>	Yes	p. 9-40
Gamma Value for YCbCr Received jobs	Gamma 1.0, Gamma 1.4, Gamma 1.8 <sup>*1</sup> , Gamma 2.2	Yes	p. 9-32

\*1 Indicates the default setting.

\*2 Indicates item that appears only if the optional Super G3 FAX Board or Super G3 Multi-Line Fax Board is installed.

\*3 Indicates item that appears only if the optional Universal Send PDF Advanced Feature Set is activated.

\*4 Indicates item that appears only if the optional Universal Send PDF Security Feature Set is activated.

\*5 Indicates item that appears only if the optional Digital User Signature PDF Kit is activated.

■ Fax Settings<sup>\*2</sup>

Item	Settings	Delivered	Applicable Page
<b>User Settings</b>			
Unit Telephone #	20 digits maximum	No	p. 1-16
Tel Line Type	Pulse, Tone <sup>*1</sup>	No	p. 1-14
Volume Control	Alarm Volume: 0 to 8; 4 <sup>*1</sup> Monitor Volume: 0 to 8; 4 <sup>*1</sup>	Yes	p. 9-42
<b>TX Settings</b>			
ECM TX	On <sup>*1</sup> , Off	Yes	p. 9-43
Pause Time	1 to 15 seconds; 2 seconds <sup>*1</sup>	Yes	p. 9-44
Auto Redial	On <sup>*1</sup> Option: Redial Times: 1 to 10 times; 2 times <sup>*1</sup> Redial Interval: 2 to 99 minutes; 2 minutes <sup>*1</sup> TX Error Resend: Error and 1st page <sup>*1</sup> , All pages, Off Off	Yes	p. 9-45
Check Dial Tone Before Sending	On <sup>*1</sup> , Off	Yes	p. 9-47
<b>RX Settings</b>			
ECM RX	On <sup>*1</sup> , Off	Yes	p. 9-48
<b>Dual Line Options<sup>*6</sup></b>			
Unit Telephone #	20 digits maximum	No	p. 9-49
Unit Name	24 characters maximum	No	p. 9-50
Tel Line Type	Pulse, Tone <sup>*1</sup>	No	p. 9-51
TX Line Selection	Line 1: Priority TX <sup>*1</sup> , Prohibit TX Line 2: Priority TX, Prohibit TX	No	p. 9-52

\*1 Indicates the default setting.

\*2 Indicates item that appears only if the optional Super G3 FAX Board or Super G3 Multi-Line Fax Board is installed.

\*6 Indicates item that appears only if the optional Super G3 Multi-Line Fax Board is installed.

 **NOTE**

- For instructions on setting the modes not described in this manual, refer to the other manuals listed in "Manuals for the Machine," on p. ii.
- The Communications Settings screen consists of a list of individual settings. Select the item and press [▼] or [▲] to scroll to the desired setting.
- Information that is delivered when the Device Information Delivery Settings mode is set, is marked with "Yes" in the "Delivered" column. For instructions on setting the Device Information Delivery Settings mode, see Chapter 6, System Manager Settings, in the *Reference Guide*.

# Automatic Document Deletion

---

If transmission of a document has failed, this mode automatically erases that document from memory.

---

**1** Press  (Additional Functions) → [Communications Settings] → [TX Settings] under <Common Settings> → [Erase Failed TX].

**2** Select [On] or [Off] → press [OK].

Details of each item are shown below.

[On]: Erases jobs after sending, whether the transmission ends successfully or with an error.

[Off]: Stores a job in memory if the transmission ends in an error. On the System Monitor screen, you can resend jobs whose transmissions have failed, or change the destinations and resend the jobs. (See "Changing the Destination," on p. 8-5, and "Resending a Job," on p. 8-7.)

 **IMPORTANT**

Even if the Erase Failed TX mode is set to 'Off', fax documents sent in the Direct Sending or Manual Sending mode, or sent from computers via the fax driver do not remain in memory when the transmission ends in an error.



# Data Compression Ratio for Color Send Jobs

You can set the compression ratio for color scanned data. A high compression ratio reduces the amount of memory used for the document, but results in low quality images. On the contrary, a low compression ratio increases the amount of memory used for the document, but results in high quality images.

## NOTE

- If [PDF (Compact)] or [PDF (Trace)] is selected as the file format, set [Data Compression Ratio] to 'Normal' or 'Low Ratio' in TX Settings under <Common Settings> in Communications Settings (from the Additional Functions screen). If [Data Compression Ratio] is set to 'High Ratio', the images that are output may be of a low quality even if 'Image Priority' is selected in Image Level for PDF (Compact) in TX Settings under <Common Settings> in Communications Settings (from the Additional Functions screen).
- If the optional Super G3 FAX Board or Super G3 Multi-Line Fax Board is installed, and you are sending documents by fax, this setting is disabled.

**1** Press  (Additional Functions) → [Communications Settings] → [TX Settings] under <Common Settings> → [Data Compression Ratio].

**2** Select [High Ratio], [Normal], or [Low Ratio] → press [OK].

Details of each item are shown below.

[High Ratio]: A small amount of memory is used for the document, but the images are of a low quality.

[Normal]: The amount of memory used for the document and the quality of the images are moderate, between the High and Low Ratio settings.

[Low Ratio]: A large amount of memory is used for the document, but the images are of a high quality.

# Handling Documents That Fail to Be Forwarded

You can set how the machine handles the documents that fail to be forwarded.

## NOTE

If Erase Failed TX in TX Settings under <Common Settings> in Communications Settings (from the Additional Functions screen) is set to 'Off', the status of any job with a forwarding error will be saved on the System Monitor screen. The document will not be processed according to the settings you make for Handle Documents with Forwarding Errors. (See "Automatic Document Deletion," on p. 9-10.)

---

**1** Press **Ⓢ** (Additional Functions) → [Communications Settings] → [TX Settings] under <Common Settings> → [Handle Documents with Forwarding Errors].

**2** Select [Always Print], [Store/Print], or [Off] → press [OK].

Details of each item are shown below.

[Always Print]: Documents that fail to be forwarded are printed.

[Store/Print]: Documents that fail to be forwarded are stored in the Memory RX Inbox. The machine automatically prints the documents that fail to be forwarded if Use Fax Memory Lock or Use I-Fax Memory Lock mode is set to 'Off'. (See "Storing Received Fax Documents in Memory," on p. 11-10, "Storing Received I-Fax Documents in Memory," on p. 11-11.)

[Off]: Documents that fail to be forwarded are not printed.

# Number of Retry Attempts

---

Retry Times is the mode which automatically resends data when the data cannot be sent. This occurs because the receiver is busy sending or receiving, or when an error occurs. This setting determines the number of retry attempts. You can set from one to five retry attempts, or select '0' to turn the Retry Times mode 'Off'.

 **NOTE**

If the optional Super G3 FAX Board or Super G3 Multi-Line Fax Board is installed and you are sending documents by fax, this setting is disabled.

---

- 1** Press  (Additional Functions) → [Communications Settings] → [TX Settings] under <Common Settings> → [Retry Times].
- 2** Press [-] or [+] to set the number of Retry Times → press [OK].

If the number of retry times is set to '0', the machine will not resend the data.

# Standard Send Settings

This mode enables you to change the standard settings for the Send function, including the scan mode and file format. (See "Selecting a Scan Mode," on p. 3-2, and "Sending Methods," on p. 5-2.)

## NOTE

- If the optional Super G3 FAX Board or Super G3 Multi-Line Fax Board is installed and you are sending documents by fax, the file format set here is disabled.
- You can change the file format.
- If you send documents by fax or I-fax, the file format set here is disabled. However, if [PDF (Trace)] or [PDF (Compact)] is selected as the file format in the Standard Send Settings and you are sending documents by fax or I-fax, a message prompting you to change the file format may appear on the screen. If this happens, change the File Format setting to anything other than [PDF (Trace)] or [PDF (Compact)].

- 1** Press  (**Additional Functions**) → **[Communications Settings]** → **[TX Settings]** under **<Common Settings>** → **[Edit Standard Send Settings]**.
- 2** Specify each setting → press **[OK]**.

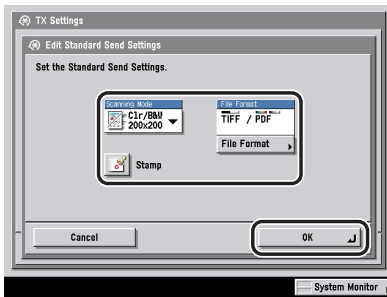

[Scanning Mode]:

Press the Scanning Mode drop-down list → select a scan mode.

You can also select a scan mode that you have already stored. (See "User Preset Keys," on p. 4-17.)

[Stamp]:

Press [Stamp].

To cancel this setting, press [Stamp] again.

[File Formats]:

Press [File Format] → select a file format.

The file format can be selected from the following formats. For more information on each format, see the following section.

- [TIFF/PDF Auto Select], [TIFF/JPEG Auto Select], [JPEG], [TIFF]: See "Setting the File Format," on p. 5-22.
- [PDF]:
  - [Compact]: See "Sending a Compact PDF," on p. 5-25.
  - [Trace & Smooth]: See "Trace & Smooth," on p. 5-27.
  - [OCR (Text Searchable)]: See "Sending a Searchable PDF," on p. 5-28.



#### NOTE

- For more information on the different file formats, see "File formats," in the Glossary on p. 14-28.
- [Trace & Smooth] appears only if the optional Universal Send PDF Advanced Feature Set is activated.
- [Compact] appears only if the optional Universal Send PDF Advanced Feature Set is activated.
- [OCR (Text Searchable)] appears only if the optional Universal Send PDF Advanced Feature Set is activated.
- To cancel all settings and return the machine to the Standard mode on the Send Basic Features screen, press  (Reset).

# Favorites Buttons

You can set any possible combination of send settings and register them in a favorites button in memory. There are 18 favorites buttons and they can be assigned names and comments for increased convenience. This feature is useful for registering frequently used send settings.

## NOTE

- The send settings registered as favorites buttons in memory are not erased, even if the power is turned OFF.
- If an address included in a favorites button is deleted from the Address Book, it is also deleted from the settings registered in the favorites button.

## Registering a Favorites Button

- 1 Specify the send settings that you want to register → press **[F]** (**Additional Functions**) → **[C]** (**Communications Settings**) → **[TX]** (**Settings**) under **<Common Settings>** → **[R]** (**Register Favorites Button**).
- 2 Select a Favorites Button (**[M1]** to **[M18]**) for registering the send settings → press **[R]** (**Register/Edit**).

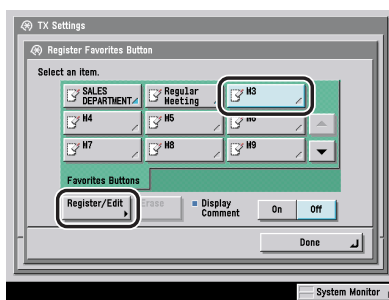

## NOTE

Keys that already have settings stored in them are displayed with a colored triangle () in the lower right corner of the key.

### 3 Press [Store].



#### NOTE

- If you select a key that already has settings stored in it, the settings are displayed.
- You can assign a name to a favorites button by pressing [Name].
- You can also assign a comment to a favorites button by pressing [Comment].

#### ● If you select a key without settings:

- A screen appears, asking for your confirmation to store the settings → press [Yes].

#### ● If you select a key that already has settings stored in it:

- A screen appears, asking for your confirmation to overwrite the previous settings → press [Yes].

## Naming a Favorites Button

**1 Press  (Additional Functions) → [Communications Settings] → [TX Settings] under <Common Settings> → [Register Favorites Button].**

**2 Select a Favorites Button ([M1] to [M18]) to name → press [Register/Edit].**

If necessary, see the screen shot in step 2 of "Registering a Favorites Button," on p. 9-16.



#### NOTE

Keys that already have settings stored in them are displayed with a colored triangle (  ) in the lower right corner of the key.

### 3 Press [Name].



#### NOTE

- If you select a key that already has settings stored in it, the settings are displayed.
- You can also name keys with no settings stored in them.

## 4 Enter a name → press [OK].



### NOTE

If you press [OK] without entering any characters, the key name reverts to its current name (default M1 to M18).

## Registering a Comment for a Favorites Button

### 1 Press (Additional Functions) → [Communications Settings] → [TX Settings] under <Common Settings> → [Register Favorites Button].

If Display Comment is set to 'On', the registered comments are displayed to the right of the favorites button when you press [Favorites] on the Send Basic Features screen.

### 2 Select a Favorites Button ([M1] to [M18]) to register with a comment → press [Register/Edit].

If necessary, see the screen shot in step 2 of "Registering a Favorites Button," on p. 9-16.



### NOTE

Keys that already have settings stored in them are displayed with a colored triangle () in the lower right corner of the key.

### 3 Press [Comment].



### NOTE

- If you select a key that already has settings stored in it, the settings are displayed.
- You can also register comments on keys with no settings stored in them.

### 4 Enter a comment → press [OK].



# Erasing a Favorites Button

- 1** Press **Ⓜ** (Additional Functions) → [Communications Settings] → [TX Settings] under <Common Settings> → [Register Favorites Button].
- 2** Select the favorites button with the send settings that you want to erase → press [Erase].

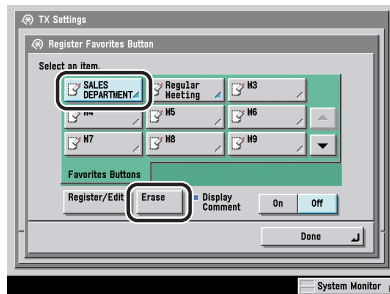

## IMPORTANT

Make sure to check the settings first before erasing them.

## NOTE

- Keys that already have settings stored in them are displayed with a colored triangle (▲) in the lower right corner of the key.
- If you select a key that already has settings stored in it, the settings are displayed.

## **3** Press [Yes].

## NOTE

- Key names are not erased. For instructions on changing a key name, see "Naming a Favorites Button," on p. 9-17.
- Comments are not erased. For instructions on changing a comment, see "Registering a Comment for a Favorites Button," on p. 9-18.

# Displaying Confirmation for Favorites Buttons

---

This mode enables you to set whether to display a confirmation screen when recalling favorites buttons.

---

- 1 Press  (Additional Functions) → [Communications Settings] → [TX Settings] under <Common Settings> → [Display Confirmation for Favorites Button].**

Details of each item are shown below.

[On]: A confirmation screen is displayed when a favorites button is recalled.

[Off]: A confirmation screen is not displayed when a favorites button is recalled.

# PDF Compression Priority

If PDF (Trace) or PDF (Compact) is selected as the file format, you can set the image quality level of the document.

## NOTE

- This mode is available only if the optional Universal Send PDF Advanced Feature Set is activated.
- If the optional Super G3 FAX Board or Super G3 Multi-Line Fax Board is installed and you are sending documents by fax, this setting is disabled.

**1** Press  (Additional Functions) → [Communications Settings] → [TX Settings] under <Common Settings> → [Image Level for PDF (Compct)].

**2** Specify each setting → press [OK].

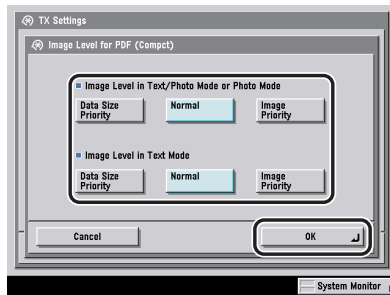

Details of each item are shown below.

[Data Size Priority]: The data size is small, but the image quality is low.

[Normal]: The data size and image quality are between the Data Size Priority and Image Priority settings.

[Image Priority]: The data size is large, but the image quality is high.

 NOTE

- The setting made for <Image Level in Text Mode> or <Image Level in Text/Photo Mode or Photo Mode> is enabled only if the Text/Photo mode or Photo mode is selected from the Original Type drop-down list. However, if [PDF (Trace)] is selected as the file format and Text mode selected as the original type, this setting is disabled.
- If an original with many colors is scanned, the compression level is determined by the data size and the number of colors, according to the selected image level. However, if the original is in monochrome or has few colors, it does not matter which image level you select.

# PDF (OCR) Mode

This mode enables you to perform OCR (optical character recognition) on a scanned original to create a PDF with searchable text.

You can set the Smart Scan mode and the Document Name OCR mode. Smart Scan is a mode which automatically detects the orientation of the characters on the original when sending it. The Document Name OCR mode enables you to use text extracted from the original as the filename of the document to be sent. You can set the number of characters to use for Document Name OCR. (See "Sending Methods," on p. 5-2.)

## NOTE

- This mode is available only if the optional Universal Send PDF Advanced Feature Set is activated. For more information on the different file formats, see "File formats," in the Glossary on p. 14-28.
- The encrypted PDF mode and [DocName OCR] cannot be used at the same time.

**1** Press  (Additional Functions) → [Communications Settings] → [TX Settings] under <Common Settings> → [PDF (OCR) Settings].

**2** Specify each setting → press [OK].

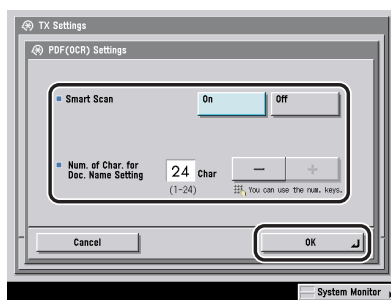

<Smart Scan>:

[On]: The orientation of the original is detected, and the document is automatically rotated before sending.

[Off]: The orientation of the original is not detected, and the document is sent as is.

<Number of Characters for Document Name Setting>:

Press [-] or [+] to set the number of characters.

# Confirming the Device Signature Certificate

You can confirm the certificate and key pair required for adding a device signature to PDF files.

## IMPORTANT

You cannot press [Check Device Signature Certificate] if the certificate and key pair for adding a device signature have not been generated. For more information on the certificate and key pair for adding a device signature, see Chapter 3, "Using a TCP/IP Network," in the *Network Guide*.

## NOTE

This function is only available if the optional Universal Send PDF Security Feature Set is activated.

- 1** Press  (Additional Functions) → [Communications Settings] → [TX Settings] under <Common Settings> → [Check Device Signature Certificate].
- 2** To verify a certificate, select the certificate you want to verify → press [Certificate Details] → [Certificate Verification].

## NOTE

<Certificate Thumbprint> contains sender information used to validate the reliability of a PDF with a device signature, by matching it with the MD5 or SHA-1 message digest number. For more information on confirming <Certificate Thumbprint> and other device signature information, see Chapter 3, "Using a TCP/IP Network," in the *Network Guide*.

# Checking a User Signature Certificate

---

You can confirm the certificate and key pair required for adding a user signature to PDF files.

## IMPORTANT

You cannot press [Check User Signature Certificate] if the certificate and key pair for adding a user signature have not been installed. For more information on installing a user certificate, see the *Remote UI Guide*.

## NOTE

This function is available only if the optional Digital User Signature PDF Kit is activated, and you are logged in to the machine using the SDL or SSO login service.

---

- 1** Press  (Additional Functions) → [Communications Settings] → [TX Settings] under <Common Settings> → [Check User Signature Certificate].
- 2** To verify a certificate, select the certificate you want to verify → press [Certificate Details] → [Certificate Verification].



# Initial Send Screen Display

This mode enables you to set whether [Favorites], [One-touch], or [New Address] tabs will be displayed on the initial Send Basic Features screen when the power is turned ON, or the Auto Clear mode is activated. You can also switch the screen to the Send Basic Features screen, which displays enlarged Favorites Buttons.

- 1** Press **Ⓜ** (**Additional Functions**) → **[Communications Settings]** → **[TX Settings]** under **<Common Settings>** → **[Default Screen for Send]**.
- 2** Select **[Favorites Buttons]**, **[One-touch Buttons]**, or **[New Address]** → press **[OK]**.

● **If you select [Favorites Buttons]:**

- Select **[On]** or **[Off]** for **<Enlarged Display>** → press **[OK]**.

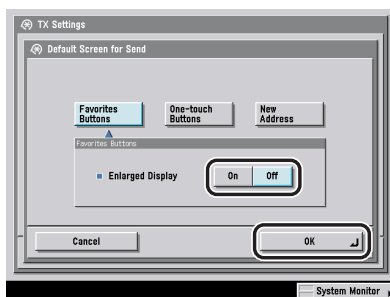

<Enlarged Display>:

[On]: Switches the screen to the Send Basic Features screen, and displays enlarged favorites buttons.

[Off]: Switches the screen to the Send Basic Features screen, and displays regular size favorites buttons.

# Printing the TX Terminal ID

The TX Terminal ID setting enables you to specify whether the Terminal ID information is printed at the top of every document that you send via fax or I-fax. Information such as your fax number, name, and I-fax address is printed, enabling the recipient to know who sent the document.

 **IMPORTANT**

In the United States, this setting must be set to 'On'. Please see "FCC (Federal Communications Commission)," on p. xvi, and "Things You Must Do Before Using This Machine," on p. 1-11, for details on FCC rules governing the use of facsimile equipment in the United States.

**1** Press  (Additional Functions) → [Communications Settings] → [TX Settings] under <Common Settings> → [TX Terminal ID].

**2** Select [On] or [Off].

● If you select [On] (The optional Super G3 FAX Board or Super G3 Multi-Line Fax Board is not installed):

Specify each setting → press [OK].

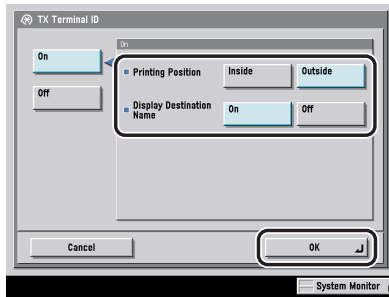

< Printing Position>:

[Inside]: The Terminal ID information is printed inside the image area on the recipient's paper.

[Outside]: The Terminal ID information is printed outside the image area on the recipient's paper.

<Display Destination Name>:

[On]: The destination name registered in the Address Book is displayed in the Terminal ID information.

[Off]: The destination name registered in the Address Book is not displayed in the Terminal ID information.

Example: If you set TX Terminal ID and Display Destination Name to 'On', the Terminal ID information is printed on the recipient's paper as follows:

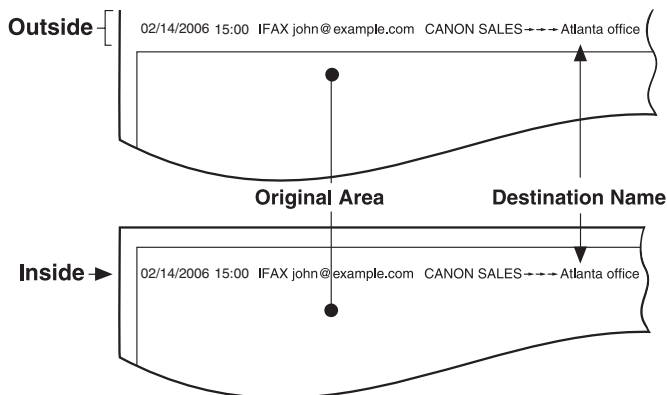

● **If you select [On] (The optional Super G3 FAX Board or Super G3 Multi-Line Fax Board is installed):**

Specify each setting → press [OK].

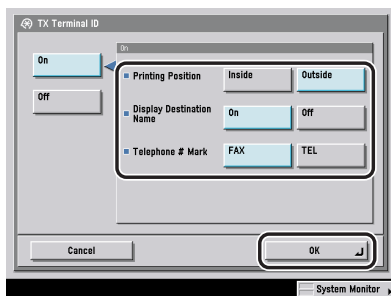

<Printing Position>:

[Inside]: The Terminal ID information is printed inside the image area on the recipient's paper.

[Outside]: The Terminal ID information is printed outside the image area on the recipient's paper.

<Display Destination Name>:

[On]: The destination name registered in the Address Book is displayed in the Terminal ID information.

[Off]: The destination name registered in the Address Book is not displayed in the Terminal ID information.

<Telephone # Mark>:

[FAX]: "FAX" is printed before the fax number.

[TEL]: "TEL" is printed before the telephone number.

Example: If you set TX Terminal ID and Display Destination Name to 'On', the Terminal ID information is printed on the recipient's paper as follows:

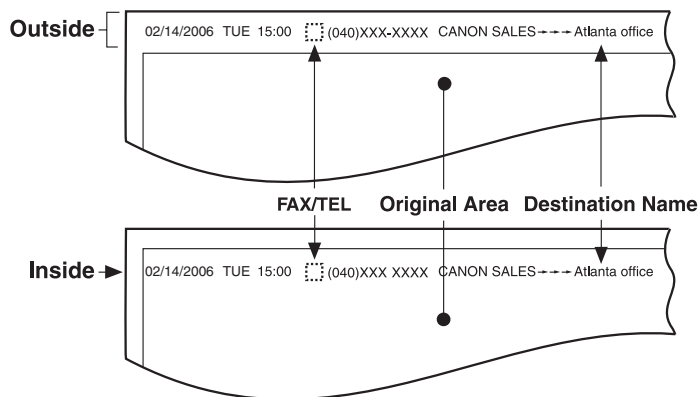

● If you select [Off]:

- Press [OK].

# Dividing Data Into Chunks When Sending With WebDAV

Chunked encoding is a function for sending a file with an unknown size by dividing it into chunks of a known length. It enables the sending time to be reduced because it is not necessary to calculate the size of the file before sending it.

You can set whether to divide data into chunks when sending with WebDAV.

## IMPORTANT

- You may not be able to send files with chunked encoding, depending on certain conditions for the WebDAV server and proxy server.
- You cannot divide data into chunks when sending with WebDAV if you are using a proxy server.
- A sending error may occur if the destination server does not support chunked encoding.

## NOTE

If [Use Chunked Encoding with WebDAV Sending] is set to 'Off', the speed when sending with WebDAV is slightly slower than normal.

**1** Press  (Additional Functions) → [Communications Settings] → [TX Settings] under <Common Settings> → [Use Chunked Encoding with WebDAV Sending].

**2** Select [On] or [Off] → press [OK].

Details of each item are shown below.

[On]: Divide data into chunks when sending with WebDAV.

[Off]: Do not divide data into chunks when sending with WebDAV.

## Gamma Value for YCbCr Send Jobs

---

If you are sending to an e-mail or file server destination, you can specify the gamma value used when converting scanned RGB image data to YCbCr. By setting a gamma value corresponding to the gamma value at the receiving end, sent image data can be printed with the appropriate image quality at the receiving end.

 **NOTE**

If the optional Super G3 FAX Board or Super G3 Multi-Line Fax Board is installed and you are sending documents by fax, this setting is disabled.

---

- 1** Press  (**Additional Functions**) → [**Communications Settings**] → [**TX Settings**] under <**Common Settings**> → [**Gamma Value for YCbCr Send Jobs**].
- 2** Select the gamma value ([**Gamma 1.0**], [**Gamma 1.4**], [**Gamma 1.8**], or [**Gamma 2.2**]) → press [**OK**].

# Initializing TX Settings

---

You can restore almost all of the TX settings to their default settings.



## IMPORTANT

You cannot initialize the Sender's Names (TTI), Unit Name, Handle Documents with Forwarding Errors, and TX Terminal ID settings.



## NOTE

If you initialize the TX Settings, the settings stored in the favorites buttons are also initialized.

---

- 1** Press  (Additional Functions) → [Communications Settings] → [TX Settings] under <Common Settings> → [Initialize TX Settings].
- 2** Press [Yes].

## 2-Sided Printing

---

You can print received documents on both sides of the paper you select. This enables you to save paper.

---

- 1** Press  (Additional Functions) → [Communications Settings] → [RX Settings] under <Common Settings> → [2-Sided Print].
- 2** Select [On] or [Off] → press [OK].



# Paper Drawer Selection

You can set how the machine prints documents when there is no paper matching the size of the received document.

There are four printing methods (Switches A, B, C, and D):

- Switch A: The image is printed over two sheets of paper that have the same combined size as the received document.

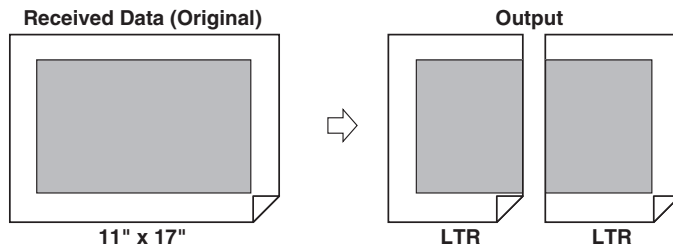

- Switch B: The image is printed with blank space on paper that has the same width as the received document.

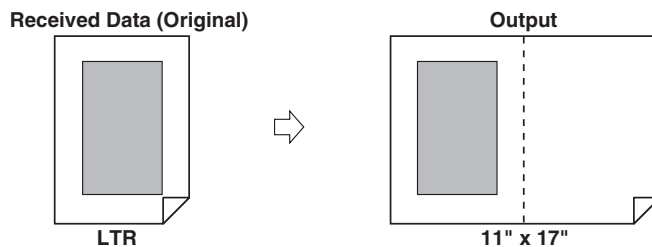

- Switch C: The image is reduced and printed on paper that differs in width from the received document.

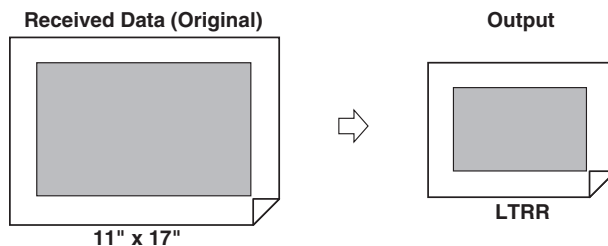

- Switch D: The image is printed on paper that is larger in size than the received document.

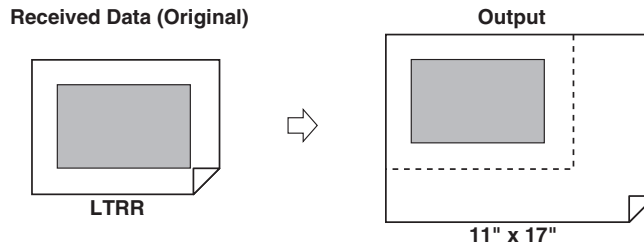

 NOTE

For more information on selecting a paper source for printing received documents, see Chapter 4, "Customizing Settings," in the *Reference Guide*.

- 
- 1** Press  (Additional Functions) → [Communications Settings] → [RX Settings] under <Common Settings> → [Select Drawer].
  - 2** Select [On] or [Off] for the respective switches → press [OK].

# Reducing a Received Document

---

You can set the machine to automatically reduce received documents so that the whole document is printed within the printable area of the paper.

---

**1** Press  (Additional Functions) → [Communications Settings] → [RX Settings] under <Common Settings> → [Receive Reduction].

**2** Select [On] or [Off].



#### IMPORTANT

- If you select [Off], the received document is not automatically reduced to fit the size of the paper. If the size of the received document exceeds the printable area, the image is divided into equal sections and printed onto separate sheets of paper.
- Regardless of the settings you set for Receive Reduction, if the area of the image which exceeds the printable area is less than 1/2" (12 mm), it will not be printed.

● If you select [On]:

- Specify each setting → press [OK].

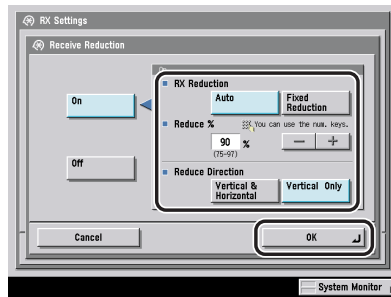

<RX Reduction>:

[Auto]: The image is automatically reduced by a suitable reduction ratio that can range from the value set for <Reduce %> up to 100% of the received document size.

[Fixed Reduction]: The image is reduced by the reduction ratio set for <Reduce %>.

<Reduce %>:

Press [-] or [+] to specify the reduction ratio.

<Reduce Direction>:

[Vertical & Horizontal]: The image is reduced in both the vertical and horizontal directions.

[Vertical Only]: The image is reduced in the vertical direction only.

● If you select [Off]:

- Press [OK].

# Printing Footer Information on a Received Document

You can set whether the machine prints the date, day, and time received, transaction number, and page number at the bottom of the received document.

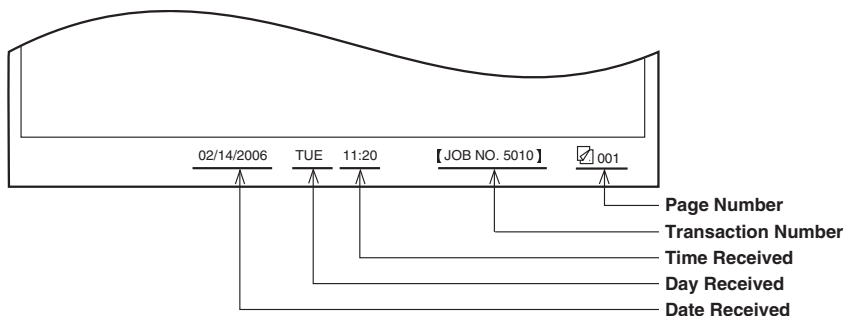

- 1** Press **Ⓜ** (Additional Functions) → [Communications Settings] → [RX Settings] under <Common Settings> → [Received Page Footer].
- 2** Select [On] or [Off] → press [OK].

## 2 On 1 Log

---

This mode enables you to print two received documents of the same paper size onto a single sheet of paper.

The 2 On 1 Log mode is available only under the following conditions:

- The same paper drawer must be selected for printing two consecutive pages of the received document.
- The paper in the selected paper drawer must be large enough for two consecutive pages to be printed out.
  - Example: If the LTR paper drawer is empty, but the 11" x 17" drawer is loaded, you can print two LTR documents onto a single sheet of 11" x 17" paper.

### NOTE

When the 2 On 1 Log mode is set to 'On', documents are printed with a dotted line in the middle. If the document is received with sender information, the dotted line is not printed in the area where the sender information is located.

---

**1** Press  (Additional Functions) → [Communications Settings] → [RX Settings] under <Common Settings> → [2 On 1 Log].

**2** Select [On] or [Off] → press [OK].

# Gamma Value for YCbCr Received Jobs

---

You can set the gamma value to use when receiving documents. This enables you to print received documents with the appropriate image quality.

 **NOTE**

If the optional Super G3 FAX Board or Super G3 Multi-Line Fax Board is installed and you are sending documents by fax, this setting is disabled.

---

- 1** Press  (**Additional Functions**) → [**Communications Settings**] → [**RX Settings**] under <**Common Settings**> → [**Gamma Value for YCbCr Received Jobs**].
- 2** Select the gamma value ([**Gamma 1.0**], [**Gamma 1.4**], [**Gamma 1.8**], or [**Gamma 2.2**]) → press [**OK**].

# Adjusting the Alarm and Monitor Volume

---

You can set the volume for the alarm and monitor tones that this machine sounds during a fax transmission.

 **NOTE**

- This mode is available only if the optional Super G3 FAX Board or Super G3 Multi-Line Fax Board is installed.
- The alarm tone sounds when sending or receiving is canceled.
- The monitor tone sounds when it connects to the recipient's fax machine.

---

**1** Press **Ⓞ** (**Additional Functions**) → **[Communications Settings]** → **[User Settings]** under **<Fax Settings>** → **[Volume Control]**.

**2** Select **[<]** or **[>]** to set the **Alarm Volume and Monitor Volume** → press **[OK]**.

You can set the volume to any level on a scale of 0 to 8.

If you set the volume all the way to the left, the volume is muted and no tone will sound.



# ECM Transmission

ECM (Error Correction Mode) reduces the effect of system and line errors on documents that occur during sending or receiving with another fax machine that supports ECM. If the other machine does not support ECM, this setting is ignored. If transmission speed appears to be extremely slow, you may be able to speed up transmission time by turning ECM 'Off'.

## IMPORTANT

- If you want to transmit using ECM, it is necessary that ECM Transmission be set in both the destination machine and this machine. This function does not operate unless ECM is set in both machines.
- Even when ECM is set, errors can sometimes occur due to a poor telephone line connection.
- If there is trouble with the line, it will take more time to send the documents.

## NOTE

This mode is available only if the optional Super G3 FAX Board or Super G3 Multi-Line Fax Board is installed.

- 1** Press  (Additional Functions) → [Communications Settings] → [TX Settings] under <Fax Settings> → [ECM TX].
- 2** Select [On] or [Off] → press [OK].

# Pause Time

---

Some overseas dialing may be affected by the distance or complex routing of connections when dialing the international access code, country code, and the destination's telephone number all at once. In such cases, insert a pause after the international access code. When the machine dials the number, it will pause where the pause was inserted in the number. This helps to improve the connection.

## NOTE

- This mode is available only if the optional Super G3 FAX Board or Super G3 Multi-Line Fax Board is installed.
- You can insert a pause on the screen where you specify the fax number. (See "Specifying a Fax Number," on p. 2-2.)
- Pauses entered at the end of dialed fax numbers are always 10 seconds long.

- 
- 1** Press  (Additional Functions) → [Communications Settings] → [TX Settings] under <Fax Settings> → [Pause Time].
  - 2** Press [-] or [+] to set the pause time → press [OK].

# Auto Redial

Auto Redial enables the machine to automatically redial the recipient's fax number if the recipient cannot be reached due to a busy line, or if a sending error occurs.

Auto Redial can be turned 'On' or 'Off'. If you set Auto Redial to 'On', you can set how many times the machine redials, the redial interval, and whether the document should be resent due to an error.

## NOTE

- This mode is available only if the optional Super G3 FAX Board or Super G3 Multi-Line Fax Board is installed.
- If a sending error occurs when the receiving end answers the call, it may be because of a misdialled number. To prevent the machine from constantly redialing to the same number even though it was wrong, the machine will only redial once, regardless of the Redial Times setting. However, if the receiving end does not answer the call, the machine will dial the number of times set for the Redial Times setting.

**1** Press  (Additional Functions) → [Communications Settings] → [TX Settings] under <Fax Settings> → [Auto Redial].

**2** Select [On] or [Off].

● If you select [On]:

- Press [Option] → specify each setting → press [OK] → [OK].

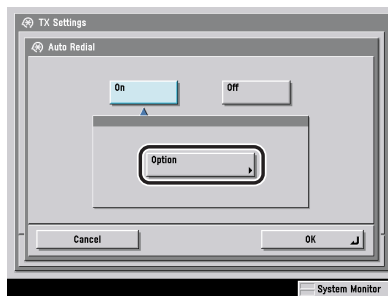

<Redial Times>:

Press [-] or [+] to set the number of redial times.

<Redial Interval>:

Press [-] or [+] to set the redial interval.

<TX Error Resend>:

[Error and 1st page]: Auto Redial takes place if a sending error occurs. The first page of the document, the error page, and all subsequent pages are resent.

[All pages]: Auto Redial takes place if a sending error occurs. All pages of the document are resent.

[Off]: Redialing does not take place if a sending error occurs.

● **If you select [Off]:**

- Press [OK].

# Checking the Dial Tone before Sending

The following redirection problem may happen with certain kinds of fax machines on the market made by companies other than Canon. The Check Dial Tone Before Sending mode prevents this rare occurrence from happening.

If you are sending a fax document from your machine at the same time another fax machine (made by a company other than Canon) is trying to send you a fax, your fax document may end up being redirected to that fax machine, instead of the original destination you had intended.

Setting Check Dial Tone Before Sending to 'On' enables you to avoid such sending problems.

## IMPORTANT

If the phone line your machine is using is connected to a PBX or network adapter, you may not be able to send faxes if Check Dial Tone Before Sending mode is set to 'On'.

## NOTE

This mode is available only if the optional Super G3 FAX Board or Super G3 Multi-Line Fax Board is installed.

**1** Press  (Additional Functions) → [Communications Settings] → [TX Settings] under <Fax Settings> → [Check Dial Tone Before Sending].

**2** Select [On] or [Off] → press [OK].

## NOTE

- The Check Dial Tone Before Sending mode is enabled only after you restart the machine (the main power switch is turned OFF, and then back ON).
- For more information on how to turn the main power ON and OFF, see Chapter 1, "Before You Start Using This Machine," in the *Reference Guide*.

# ECM Reception

---

You can receive incoming documents using ECM (Error Correction Mode).

ECM is a mode which automatically corrects errors in an image while it is being received.

## IMPORTANT

- If you want to communicate using ECM, it is necessary that ECM Reception be set in both the destination machine and this machine. This function does not operate unless ECM is set in both machines.
- Even when ECM is set, errors can sometimes occur due to a poor telephone line connection.
- If there is trouble with the line, it will take more time to receive the documents.

## NOTE

This mode is available only if the optional Super G3 FAX Board or Super G3 Multi-Line Fax Board is installed.

---

- 1** Press  (Additional Functions) → [Communications Settings] → [RX Settings] under <Fax Settings> → [ECM RX].
- 2** Select [On] or [Off] → press [OK].

# Registering the Fax Number for an Additional Line

If the optional Super G3 Multi-Line Fax Board is installed, you must register a different fax number for the additional line. This number is printed on the document that you fax to the receiving party.

The number may also be displayed on the touch panel display of the receiving party's machine, depending on their type of machine.

## NOTE

This mode is available only if the optional Super G3 Multi-Line Fax Board is installed.

**1** Press  (Additional Functions) → [Communications Settings] → [Dual Line Options] under <Fax Settings> → [Unit Telephone #].

**2** Enter the machine's telephone number using  -  (numeric keys) → press [OK].

Details of each item are shown below.

[Space]: Press to insert a space between the area code and the local fax number.

[+]: Use to insert a country code. Press [+] after the country code, and before the fax number.

[◀][▶]: Press to move the position of the cursor.

[Backspace]: Press to delete the last number entered.

# Registering the Unit Name for an Additional Line

---

Your name or company's name must be registered as the unit's name (a department name is optional) for an additional line.

When you send a document, the recipient's machine displays or prints your name or company's name (and department's name, if applicable) as the sender's information on the recording paper.

Some fax models also display sender information on the touch panel display during transmission.

 **NOTE**

This mode is available only if the optional Super G3 Multi-Line Fax Board is installed.

---

- 1** Press  (**Additional Functions**) → [**Communications Settings**] → [**Dual Line Options**] under <**Fax Settings**> → [**Unit Name**].
- 2** Enter a name → press [**OK**].



# Selecting the Telephone Line Type for an Additional Line

Set the type of additional telephone line that is connected to the machine.

If this setting is incorrect, you will be unable to communicate with other machines. Be sure to check the type of telephone line that you are using, and make the correct setting.

 **NOTE**

This mode is available only if the optional Super G3 Multi-Line Fax Board is installed.

---

**1** Press  (Additional Functions) → [Communications Settings] → [Dual Line Options] under <Fax Settings> → [Tel Line Type].

**2** Select the type of telephone line → press [OK].

If you do not know the telephone line type, call your telephone service provider for details.

# Selecting the Line for Sending

You can register the method for selecting the line to use for sending.

## NOTE

- This mode is available only if the optional Super G3 Multi-Line Fax Board is installed.
- If you select another line for sending on the Send Settings screen or One-touch Buttons screen, that setting takes priority.

**1** Press  (Additional Functions) → [Communications Settings] → [Dual Line Options] under <Fax Settings> → [TX Line Selection].

**2** Select the line to use for sending → press [OK].

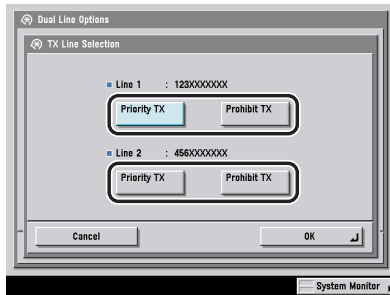

<Line 1>:

[Priority TX]: Sends with line 1 if this line is not in use.

[Prohibit TX]: Prohibits sending with line 1. (Line 1 is only used for receiving.) Documents are always sent with line 2. If line 2 is in use, the machine waits to send the document.

<Line 2>:

[Priority TX]: Sends with line 2 if this line is not in use or sends with line 1 if line 2 is in use.

[Prohibit TX]: Prohibits sending with line 2. (Line 2 is only used for receiving.) Documents are always sent with line 1. If line 1 is in use, the machine waits to send the document.



### IMPORTANT

Even if you set to prohibit using line 1 for sending document, line 1 is still used for manual sending.



# Storing/Editing Address Book Settings

# 10

CHAPTER

This chapter describes how to register various addresses in the Address Book and how to edit and erase registered information.

---

Address Book Settings Table .....	10-2
About the Address Book .....	10-3
Storing New Addresses .....	10-5
Fax Numbers .....	10-5
E-Mail Addresses .....	10-9
I-Fax Addresses .....	10-12
File Server Addresses .....	10-17
Group Addresses .....	10-19
Addresses Obtained via a Server .....	10-23
Editing Address Details .....	10-30
Erasing Addresses .....	10-33
Naming an Address Book .....	10-34
Storing/Editing One-Touch Buttons .....	10-35
Erasing One-Touch Buttons .....	10-39

# Address Book Settings Table

The following items can be stored or set in Address Book Settings from the Additional Functions screen.

Item	Settings	Delivered	Applicable Page
Register Address	Register New Address Edit Erase	Yes	p. 10-5
Register Address Book Name	Register Name	Yes	p. 10-34
One-touch Buttons	Register/Edit, Erase	Yes	p. 10-35

 **NOTE**

- For instructions on setting the modes not described in this manual, refer to the other manuals listed in "Manuals for the Machine," on p. ii.
- Information that is delivered when the Device Information Delivery Settings mode is set, is marked with "Yes" in the "Delivered" column. For instructions on setting the Device Information Delivery Settings mode, see Chapter 6, System Manager Settings, in the *Reference Guide*.

# About the Address Book

The Address Book is a feature used for storing fax, e-mail, I-fax, and file server destinations. The Address Book is divided into 10 subaddress books and one-touch buttons. You can store up to 1,800 destinations, including 1,600 destinations in the subaddress books, and 200 destinations in one-touch buttons. Registering a destination in the Address Book saves you the effort of entering that destination's address each time you send a job. By storing your own e-mail address, you can specify a reply-to e-mail address and use the Job Done Notice function.

The following types of destinations can be stored in the Address Book.

## NOTE

- Since each address entry is treated as a single entry, if an e-mail address is registered in a group address, that e-mail address and the group address are counted as two entries. In the same way, if a fax number is registered in a group address, the fax number and group address are counted as two entries.
- E-mail addresses, I-fax addresses, file server addresses, and group addresses can also be registered in the Address Book.
- If the optional Super G3 FAX Board or Super G3 Multi-Line FAX Board is installed, fax numbers in addition to the above mentioned destinations can be stored in the Address Book.
- Destinations stored in the Address Book can be exported to your computer as a file, which can later be imported in the machine. For information on exporting the Address Book, see Chapter 3, "Customizing Settings," in the *Remote UI Guide*.

## ■ Fax

You can store fax numbers, as well as subaddress and password information.

A fax number obtained by searching through the directory listings on a server on the network using LDAP can also be stored.

## ■ E-mail

You can store e-mail addresses.

An e-mail address obtained by searching through the directory listings on a server on the network using LDAP can also be stored.

## ■ I-Fax

You can store the I-fax address, the mode, and the destination conditions.

An e-mail address obtained by searching through the directory listings on a server on the network using LDAP can also be stored as an I-fax address.

## ■ File

You can register a protocol, host name, file path, etc. for storing scanned documents in a file server.

### NOTE

For examples of settings needed for sending to a file server, see the *Network Guide*.

## ■ Group

You can register multiple destinations of various types in a group address. You can group and use these registered destinations according to your needs.

### NOTE

- You cannot register new destinations in a group address. New destinations must be registered in the Address Book before you can register them as part of a group address.
- When you register destinations in a group address, you can select and store only destinations registered in the same subaddress book.



# Storing New Addresses

If you register a destination in the Address Book, you can save yourself the effort of entering the destination every time it is used. That destination can also be selected from the Address Book for use in any other customized setting.

## NOTE

- If you want to manage destinations with the Access Number Management mode, set the Access Number Management in Restrict the Send Function in System Settings (from the Additional Functions screen) to 'On'. (See "Access Number Management," on p. 11-16.)
- If there is any required destination setting that has not yet been set after registering the access number, the screen for specifying the destination settings is displayed again.
- If Use Asterisks to Enter Access No./Passwords in System Settings (from the Additional Functions screen) is set to 'Off' when Access Number Management in Restrict the Send Function in System Settings (from the Additional Functions screen) is set to 'On', the access number that you enter is not displayed as asterisks on the Access Number Settings screen. (See Chapter 6, "System Manager Settings," in the *Reference Guide*.)
- You can enter up to seven digits for the access number. If you enter fewer than seven digits, the machine stores the access number with leading zeros.  
Example: If <321> is entered, <0000321> is stored.  
You cannot store an access number with only zeros as the number, such as <0000000>. If you enter a number that begins with zeros, the leading zeros are ignored.  
Example: If <02> or <002> is entered, <0000002> is stored.

## Fax Numbers

## NOTE

This mode is available only if the optional Super G3 FAX Board or Super G3 Multi-Line FAX Board is installed.

- 1** Press  (Additional Functions) → [Address Book Settings] → [Register Address].

## 2 Press [Register New Address].

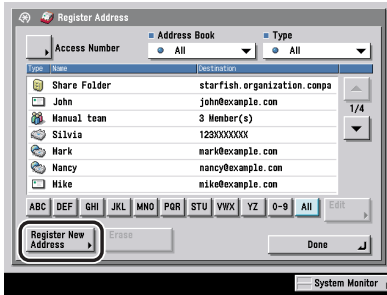

## 3 Press [Fax].

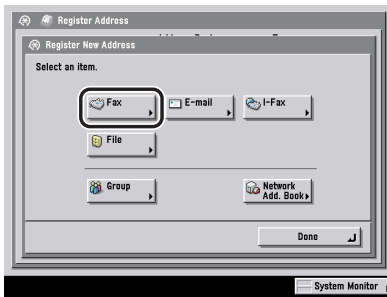

## 4 Press [Name].

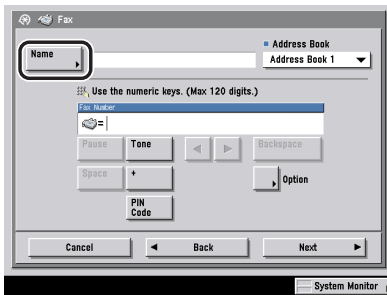

## 5 Enter a name for the recipient of the fax → press [OK].



### NOTE

The first character that you enter for the name is used for sorting the destination list when you press keys, such as [ABC], [DEF], and [GHI], on the Address Book screen.

## 6 Press the Address Book drop-down list → select one of the numbered subaddress books.

Address Books 1 to 10 are used to divide the Address Book into 10 parts, called subaddress books. This is a convenient way to classify destinations.

The fax number that you enter will be stored in the subaddress book that you select here.

## 7 Enter the recipient's fax number using 0 - 9 (numeric keys), \*, and #.

Details of each item are shown below.

- [Pause]: Press to insert a pause of several seconds in the fax number that you are dialing. If you insert a pause, the letter <p> is displayed between the numbers, and the letter <P> appears at the end of the number. When dialing an overseas number, insert a pause after the country code, and at the end of the telephone number. (See "Pause Time," on p. 9-44.)
- [Tone]: Press when you want to directly call an extension line that is connected to a PBX (Private Branch eXchange) which accepts only tone signals. If you press [Tone], the letter <T> appears. (See "Fax Information Services," on p. 7-8.)
- [◀] [▶]: Press to move the position of the cursor.
- [Backspace]: Press to delete the last number entered.
- [Space]: Press to insert a space between numbers.
- [+]: Use to insert a country code. Press [+] after the country code, and before the fax number.
- [Option]: Press to specify the subaddress, password, ECM TX, sending speed, and type of call settings. These settings are optional.
- [PIN Code]: Press to enter the PIN (Personal Identification Number) code. You can press this key only if [Option] is selected for PIN code position. If [Prefix], [Suffix], or [Off] is selected for PIN code position, this key is grayed out. (See "Using a PIN Code," on p. 7-5.)



### IMPORTANT

You cannot insert a pause or a space at the beginning of a number.



### NOTE

If you enter a pause at the end of the number, the pause is always 10 seconds long.

● If you press [Option]:

- Specify each setting → press [OK].

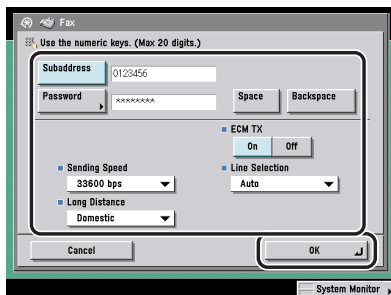

[Subaddress] and [Password]:

Press [Subaddress] → enter the recipient's subaddress using

⓪ - ⑨ (numeric keys), Ⓢ, and Ⓜ.

Press [Password] → enter the recipient's password using

⓪ - ⑨ (numeric keys), Ⓢ, and Ⓜ.

Press [Confirm] → re-enter the recipient's password for confirmation → press [OK].

Press [Space] to insert a space.

Press [Backspace] to delete the last digit entered.

If the recipient did not set a password for the target subaddress, you do not need to enter a password.

<ECM TX>:

Select [On] or [Off].

<Sending Speed>:

Press the Sending Speed drop-down list → select the desired sending speed.

If your document transmissions are slow in starting, this may mean that the telephone lines in your area are in poor condition. Select a slower speed. You can select [33600 bps], [14400 bps], [9600 bps], or [4800 bps].

<Long Distance>:

Press the Long Distance drop-down list → select the type of call.

Select [Long Distance (1)] if transmission errors occur frequently when you make overseas calls (when the number is stored in the Address Book). If errors persist, try selecting [Long Distance (2)] or [Long Distance (3)].

<Line Selection>:

Press the Line Selection drop-down list → select the line.

[Line 1]: Standard Line

[Line 2]: Additional Line

[Auto]: A line is selected according to the settings you made for TX Line Selection in Dual Line Options under <Fax Settings> in Communications Settings (from the Additional Functions screen). (See "Selecting the Line for Sending," on p. 9-52.)



### IMPORTANT

If you want to attach a subaddress to your send job, make sure that the recipient's fax machine supports ITU-T standard subaddresses.



### NOTE

- The Line Selection drop-down list is displayed only if the optional Super G3 Multi-Line FAX Board is installed.
- If Use Asterisks to Enter Access No./Passwords in System Settings (from the Additional Functions screen) is set to 'Off', the password you enter is not displayed as asterisks. (See Chapter 6, "System Manager Settings," in the *Reference Guide*.)

## 8 Finish storing the address.

### ● If Access Number Management is set to 'On':

- Press [Next].
- Press [Access Number].
- Press [Access Number] → enter the access number using ① - ⑨ (numeric keys).
- Press [Confirm] → re-enter the access number for confirmation → press [OK] → [OK].

If you do not want to set an access number for this destination, press [OK] without entering any number.

### ● If Access Number Management is set to 'Off':

- Press [OK].

## E-Mail Addresses

### 1 Press ④ (Additional Functions) → [Address Book Settings] → [Register Address] → [Register New Address].

If necessary, see the screen shots in step 1 and step 2 of "Fax Numbers," on p. 10-5.

## 2 Press [E-mail].

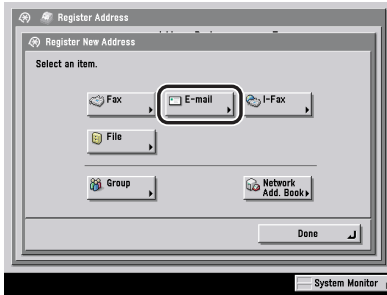

## 3 Press [Name].

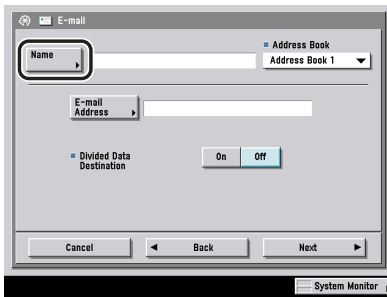

## 4 Enter a name for the e-mail address → press [OK].



### NOTE

The first character that you enter for the name is used for sorting the address list when you press keys, such as [ABC], [DEF], and [GHI], on the Address Book screen.

## 5 Press the Address Book drop-down list → select one of the numbered subaddress books.

Address Books 1 to 10 are used to divide the Address Book into 10 parts, called subaddress books. This is a convenient way to classify destinations.

The e-mail address that you enter will be stored in the subaddress book that you select here.

## 6 Press [E-mail Address] → enter the e-mail address → press [OK].

## 7 Select [On] or [Off] for <Divided Data Destination>.

Details of each item are shown below.

[On]: Select [On] if the destination's e-mail software has a function to combine divided data. If the size of the data being sent exceeds the value set for Maximum Data Size for Sending in E-mail/I-Fax Settings in Communications Settings in System Settings (from the Additional Functions screen), the data is divided into multiple parts before being sent. Once the destination machine receives all the parts of the data, it combines them into one item of data.

[Off]: Select [Off] if the destination's e-mail software has no function to combine divided data. If the size of the data being sent exceeds the value set for Maximum Data Size for Sending in E-mail/I-Fax Settings in Communications Settings in System Settings (from the Additional Functions screen), the data is divided into pages and sent as multiple e-mail messages.



### IMPORTANT

Make sure to check the specifications of the destination's e-mail software before setting this mode. A sending error may occur if the destination's e-mail software is not able to combine divided data.



### NOTE

For more information on the maximum data size for sending, see "E-Mail/I-Fax Settings," on p. 11-4.

## 8 Finish storing the address.

### ● If Access Number Management is set to 'On':

- Press [Next].
- Press [Access Number].
- Press [Access Number] → enter the access number using 0 - 9 (numeric keys).
- Press [Confirm] → re-enter the access number for confirmation using 0 - 9 (numeric keys) → press [OK] → [OK].

If you do not want to set an access number for this e-mail address, press [OK] without entering any number.

### ● If Access Number Management is set to 'Off':

- Press [OK].

# I-Fax Addresses

- 1 Press **Ⓜ** (Additional Functions) → [Address Book Settings] → [Register Address] → [Register New Address].

If necessary, see the screen shots in step 1 and step 2 of "Fax Numbers," on p. 10-5.

- 2 Press [I-Fax].

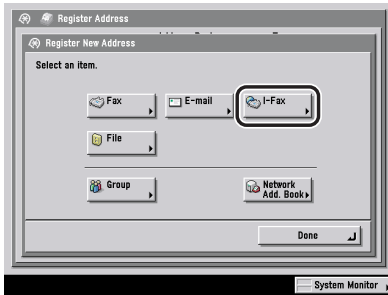

- 3 Press [Name].

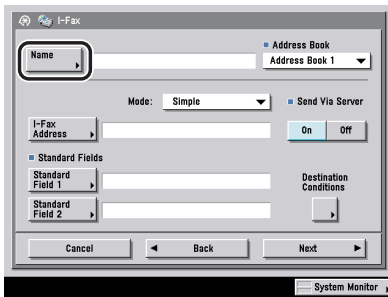

- 4 Enter a name for the I-fax address → press [OK].

## NOTE

The first character that you enter for the name is used for sorting the address list when you press keys, such as [ABC], [DEF], and [GHI], on the Address Book screen.



## 5 Press the Address Book drop-down list → select one of the numbered subaddress books.

Address Books 1 to 10 are used to divide the Address Book into 10 parts, called subaddress books. This is a convenient way to classify destinations.

The I-fax address that you enter will be stored in the subaddress book that you select here.

## 6 Press the Mode drop-down list → select [Simple] or [Full].

<Mode>:

[Simple]: Sends scanned data as an image via the Internet.

[Full]: Sends scanned data as an image via the Internet, and enables you to receive a delivery confirmation message telling you whether your I-fax was sent successfully.

In order for you to receive a confirmation message telling you the delivery status of your I-fax document, the recipient's machine must have I-fax capabilities and be compatible with the Full mode.



### NOTE

If you send documents using the Full mode to a machine that does not support the Full mode, delivery confirmation cannot be carried out. When this happens, the job concerned is not considered as complete even though the actual sending of the document is successful. Such jobs are displayed as <Waiting for result...> on the Status screen until the time set for Full Mode TX Timeout in E-mail/I-Fax Settings in Communications Settings in System Settings (from the Additional Functions screen) has lapsed. After the timeout, the job is moved to the log, and the result is shown as <-> when sending of the document to a server or other destination could not be verified.

## 7 Press [I-Fax Address] → enter the I-fax address → press [OK].



### NOTE

If you do not send documents via a server, and if the recipient's IP address is not registered with a DNS server, enter the domain name in the following format: (user)@(the recipient's IP address).

## 8 Press [Standard Field 1] and [Standard Field 2] → enter their respective standard fields → press [OK].

Standard Field 1 and Standard Field 2 are settings required for using an Internet fax service. For details, contact your service provider.

If you do not use an Internet fax service, this step is not necessary.



#### NOTE

After pressing [OK], the standard field that you entered appears as asterisks (\*\*\*\*\*) on the I-fax settings screen.

## 9 Select [On] or [Off] for <Send Via Server>.

<Send Via Server>:

[On]: Sends documents via a server. You can send documents to destinations via the Internet in the same way as e-mail.

[Off]: Does not send documents via a server. You can send large amounts of image data to a recipient within the same LAN (Local Area Network) environment without placing a burden on the mail server. This enables you to send documents quickly and directly to the recipient. To use this setting, it is necessary to set up an MX (Mail eXchange) record on the DNS server. Ask your System Manager whether this type of sending is possible before you set Send Via Server to 'Off'.

If you specify the Standard Field settings, set Send Via Server to 'On'.



#### IMPORTANT

To be able to specify the Send Via Server setting, set <Use Send Via Server> to 'On' on the E-mail/I-Fax Settings screen beforehand. It is recommended to set <Allow MDN Not Via Server> to 'On' on the same screen. To access the E-mail/I-Fax Settings screen, press  (Additional Functions) → [System Settings] → [Communications Settings] → [E-mail/I-Fax Settings]. If <Use Send Via Server> is set to 'Off', <Send Via Server> is grayed out. (See "E-Mail/I-Fax Settings," on p. 11-4.)



#### NOTE

Even if <Send Via Server> is set to 'Off', delivery confirmation of documents sent using the Full mode is carried out via the server.

## 10 Press [Destination Conditions] → select [On] or [Off] for <Receive Divided Data>.

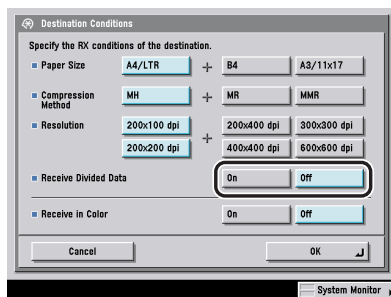

Details of each item are shown below.

[On]: Select [On] if the destination machine has a function to combine divided data. If the size of the data being sent exceeds the value set for Maximum Data Size for Sending in E-mail/I-Fax Settings in Communications Settings in System Settings (from the Additional Functions screen), the data is divided into multiple parts before being sent. Once the destination machine receives all the parts of the data, it combines them into one item of data.

[Off]: Select [Off] if the destination machine has no function to combine divided data. If the size of the data being sent exceeds the value set for Maximum Data Size for Sending in E-mail/I-Fax Settings in Communications Settings in System Settings (from the Additional Functions screen), a sending error occurs.

### IMPORTANT

Set the destination conditions according to the specifications of the recipient's machine. An error in transmission may occur if you set conditions that the recipient's machine does not support.

### NOTE

For more information on the maximum data size for sending, see "E-Mail/I-Fax Settings," on p. 11-4.

## 11 Specify the receiving conditions of the destination.

### ● If you want to send in black-and-white:

- Press [Off] for <Receive in Color>.
- Set the paper size, compression method, and resolution → press [OK].

The following conditions are always selected:

- Paper Size: A4/LTR
  - Compression Method: MH (Modified Huffman)
  - Resolution: 200 x 100 dpi and 200 x 200 dpi
- LTR, LGL, and STMT are included in [A4/LTR].

### IMPORTANT

Set the destination conditions according to the specifications of the recipient's machine. An error in transmission may occur if you set conditions that the recipient's machine does not support.

### NOTE

Available compression methods are:

- MH (Modified Huffman) - a coding system that horizontally scans and compresses extended areas of white and black dots.
- MR (Modified Read) - a coding system that horizontally and vertically scans and compresses white and black areas. Faster than MH.
- MMR (Modified Modified Read) - an adaptation of Modified Read, originally for use in digital machines. Faster than MR.

### ● If you want to send in color:

- Press [On] for <Receive in Color> → press [Next].
- Set the paper size and resolution → press [OK].

The following conditions are always selected:

- Paper Size: A4/LTR
- Resolution: 200 x 200 dpi

LTR, LGL, and STMT are included in [A4/LTR].

### IMPORTANT

Set the destination conditions according to the specifications of the recipient's machine. An error in transmission may occur if you set conditions that the recipient's machine does not support.

## 12 Finish storing the address.

### ● If Access Number Management is set to 'On':

- Press [Next].
- Press [Access Number].
- Press [Access Number] → enter the access number using ① - ⑨ (numeric keys).
- Press [Confirm] → re-enter the access number for confirmation using ① - ⑨ (numeric keys) → press [OK] → [OK].  
If you do not want to set an access number for this I-fax address, press [OK] without entering any number.

### ● If Access Number Management is set to 'Off':

- Press [OK].

## File Server Addresses

### IMPORTANT

If Language Switch in Common Settings (from the Additional Functions screen) is set to 'On', the Host Name and File Path of the file server destination may not be displayed correctly, so you may not be able to refer to them.

### NOTE

- For examples of the settings needed to send to a file server, see the *Network Guide*.
- UPN can be used only if you are sending to a computer belonging to a domain operated with Active Directory.

## 1 Press ④ (Additional Functions) → [Address Book Settings] → [Register Address] → [Register New Address].

If necessary, see the screen shots in step 1 and step 2 of "Fax Numbers," on p. 10-5.

## 2 Press [File].

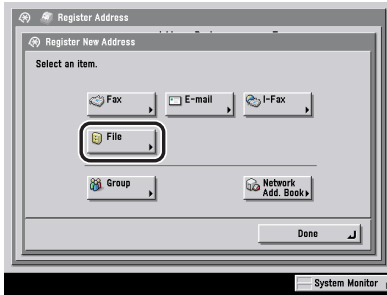

## 3 Press [Name].

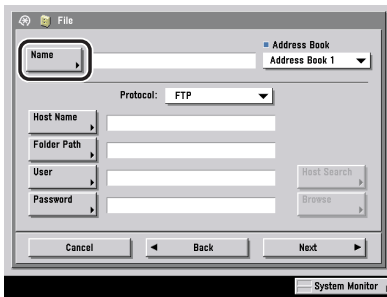

## 4 Enter a name for the file server address → press [OK].



### NOTE

The first character that you enter for the name is used for sorting the address list when you press keys, such as [ABC], [DEF], and [GHI], on the Address Book screen.

## 5 Press the Address Book drop-down list → select one of the numbered subaddress books.

Address Books 1 to 10 are used to divide the Address Book into 10 parts, called subaddress books. This is a convenient way to classify destinations.

The file server address that you enter will be stored in the subaddress book that you select here.

## 6 Press the Protocol drop-down list → select the desired protocol.



### NOTE

For more information on the available protocols, see "Using the Keyboard," on p. 2-12.

## 7 Set [Host Name], [File Path], [User], and [Password].



### NOTE

For instructions on specifying each of the settings for FTP, Windows (SMB), NetWare (IPX), and WebDAV, see "Specifying a File Server," on p. 2-11.

## 8 Finish storing the address.

### ● If Access Number Management is set to 'On':

- Press [Next].
- Press [Access Number].
- Press [Access Number] → enter the access number using  
① - ⑨ (numeric keys).
- Press [Confirm] → re-enter the access number for confirmation using  
① - ⑨ (numeric keys) → press [OK] → [OK].  
If you do not want to set an access number for this file server address, press [OK] without entering any number.

### ● If Access Number Management is set to 'Off':

- Press [OK].

## Group Addresses

The Group Address feature enables you to create a group of up to 256 stored destinations as a single destination.



### IMPORTANT

If you want to store a group address, the destinations must be stored beforehand, such as fax numbers, e-mail addresses, and file server addresses.

 NOTE

- If you want to store a group address, you can only select destinations that you registered in the same subaddress book.
- E-mail addresses, I-fax addresses, file server addresses, and a User Inbox can be stored in a group address.
- If the optional Super G3 FAX Board or Super G3 Multi-Line FAX Board is installed, fax numbers in addition to the above mentioned destinations can be stored in a group address.

**1** Press  (Additional Functions) → [Address Book Settings] → [Register Address] → [Register New Address].

If necessary, see the screen shots in step 1 and step 2 of "Fax Numbers," on p. 10-5.

**2** Press [Group].



**3** Press [Name].

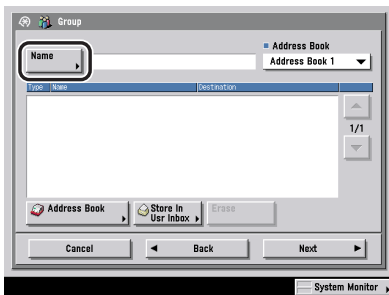



## 4 Enter a name for the group address → press [OK].



### NOTE

The first character that you enter for the name is used for sorting the address list when you press keys, such as [ABC], [DEF], and [GHI], on the Address Book screen.

## 5 Press the Address Book drop-down list → select one of the numbered subaddress books.

Address Books 1 to 10 are used to divide the Address Book into 10 parts, called subaddress books. This is a convenient way to classify destinations.

The group address that you enter will be stored in the subaddress book that you select here.

## 6 Select [Address Book] or [Store In Usr Inbox].

To store destinations in a group address, those destinations must be stored in the subaddress book that contains the group address.

You cannot store destinations from different subaddress books in the group address. For example, you cannot store e-mail addresses from Address Book 1 and file server addresses from Address Book 2 into the same group address.

### ● If you select [Address Book]:

- Select the destination → press [OK].

If Access Number Management in Restrict the Send Function in System Settings (from the Additional Functions screen) is set to 'On', and you want to select a destination that is stored with an access number, press [Access Number] → enter the access number. (See "Using the Address Book," on p. 2-23.)

To cancel a selected destination, select the destination once more to clear the check mark.

Press the alphanumeric keys (e.g., [ABC]) to display the individual keys for each letter or number. You can select a letter or number to restrict the displayed range of entries. Press [All] to return to the full address list.

You can restrict the type of destinations displayed in the results list by pressing the Type drop-down list.

You can select a destination and press [Details] to confirm the detailed information related to the selected destinations. Press [Done] to return to the previous screen.

Repeat step 6 to add other destinations.

 **NOTE**

[Access Number] is displayed on the screen only if Access Number Management in Restrict the Send Function in System Settings (from the Additional Functions screen) is set to 'On'. (See "Access Number Management," on p. 11-16.)

● **If you select [Store In Usr Inbox]:**

- Select the User Inbox from the Inbox Selection screen → press [OK].

 **NOTE**





Only one User Inbox can be stored in a group address.

● **To erase a destination:**

- Select a destination from the group address → press [Erase].

## 7 Finish storing the address.

● **If Access Number Management is set to 'On':**

- Press [Next].
- Press [Access Number].
- Press [Access Number] → enter the access number using  -  (numeric keys).
- Press [Confirm] → re-enter the access number for confirmation using  -  (numeric keys) → press [OK]. → [OK].  
If you do not want to set an access number for this group address, press [OK] without entering any number.

● **If Access Number Management is set to 'Off':**

- Press [OK].

## Addresses Obtained via a Server

You can store an address that is obtained by searching the directory listings on the network using LDAP (Lightweight Directory Access Protocol) servers.

### NOTE

- You may have to set up the LDAP servers beforehand, depending on the network environment.
- For more information on LDAP servers, see "LDAP Server Settings," on p. 11-43.
- The information that can be obtained via the LDAP server are names and e-mail addresses. If the optional Super G3 FAX Board or Super G3 Multi-Line FAX Board is installed, fax numbers in addition to the above mentioned information can be also obtained via the LDAP server.

### **1** Press (Additional Functions) → [Address Book Settings] → [Register Address] → [Register New Address].

If necessary, see the screen shots in step 1 and step 2 of "Fax Numbers," on p. 10-5.

### **2** Press [Network Add. Book].

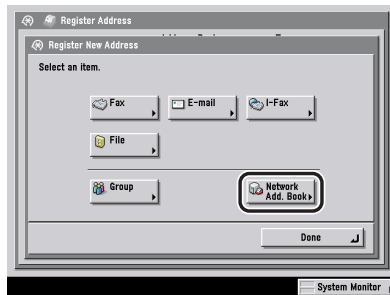

- 3** Press the **Server to Search** drop-down list → select the desired server to search.

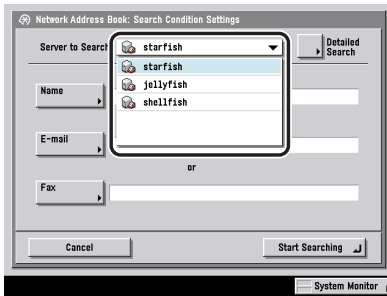

- 4** Specify the search criteria.



**NOTE**

If you want to search for a destination that is registered with an e-mail address and a fax number, you can search for the e-mail address by entering the fax number as the search criterion, and vice versa.

### ● To use Simple Search:

- ❑ Press [Name], [E-mail], or [Fax] → enter the name, e-mail address, or fax number for which you want to search → press [OK].

The search criteria boxes that are not filled out are not searched.

To make a more detailed search with multiple search conditions, press [Detailed Search], and follow the directions below. The search criteria you entered for Simple Search are continuously used in Detailed Search.

### ● To use Detailed Search:

- ❑ Press [Detailed Search].
- ❑ Press the search category drop-down list → select the desired search category.

The available search categories are:

- [Name]: Search by name.
- [E-mail]: Search by e-mail address.
- [Fax]: Search by fax number.
- [Organization]: Search by organization name.
- [OrgnztionUnit]: Search by organizational unit (e.g., departments in an organization).

For example, if cn(common name)=user1, ou(organization unit)=salesdept, o(organization)=canon, c(country)=jp is the distinguished name in the directory, enter the organization/organizationUnit of the user as follows:

```
organization=canon
organizationUnit=salesdept
```



#### NOTE

- The organization/organizationUnit can be used as search categories only if the information has been registered on the LDAP Server.
- Detailed Search by organization/organizationUnit may not be performed, depending on whether the attribute types have been registered on the LDAP server, and depending on the type of application on the server.
- You can also add additional user-defined search attributes. For more information on registering or editing a search attribute, see "Registering/Editing LDAP Search Attributes," on p. 11-49.

- ❑ Press the search condition drop-down list → select the desired search condition → press [Settings].

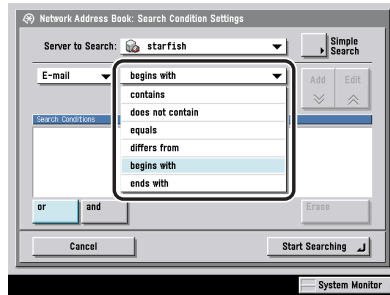

You can select from the following search conditions:

- [contains]: The result must contain the entered name, e-mail address, fax number, organization, or organizational unit.
- [does not contain]: The result must not contain the entered name, e-mail address, fax number, organization, or organizational unit.
- [equals]: The result must be exactly the same as the entered name, e-mail address, fax number, organization, or organizational unit.
- [differs from]: The result must be different from the entered name, e-mail address, fax number, organization, or organizational unit.
- [begins with]: The result must begin with the same first few letters that you entered for the name, e-mail address, fax number, organization, or organizational unit.
- [ends with]: The result must end with the same last few letters that you entered for the name, e-mail address, fax number, organization, or organizational unit.

- ❑ Enter the search criterion → press [OK].

- ❑ Press [Add].

To continue adding more search criteria, press [or] or [and] → repeat step 4.

[or]: The machine searches and returns a result for either of the specified search criteria.

[and]: The machine searches and returns a result for all of the specified search criteria.

To edit the search criteria, select the search criterion that you want to edit → press [Edit] → [Settings].

To delete the search criteria, select the criterion that you want to erase → press [Erase].

 **NOTE**

- You can specify up to four different search criteria at a time.
- If you specify three or more search criteria, you cannot use both [or] and [and] together.
- If you press [Simple Search] after specifying search criteria on the Detailed Search screen, the display changes to the Simple Search screen, and the specified detailed search criteria are deleted.

**5 Press [Start Searching].**

To cancel searching while the machine is searching for your criteria, press [Cancel]. If the machine finds some results before you press [Cancel], these search results are displayed.

 **IMPORTANT**

- Searching for a destination via an LDAP server is not possible if the time setting of the server and the time setting of the machine are more than five minutes apart. If you cannot send even when the user name and password are correct, check the time settings on the server and the machine.
- The number of search results displayed will not exceed the maximum limit set in Register LDAP Server in System Settings (from the Additional Functions screen). If the desired destination is not displayed, either increase the maximum number of addresses to search, or change the search criteria. (See "LDAP Server Settings," on p. 11-43.)

 **NOTE**

If you press [Start Searching] without specifying any search criteria, all the addresses stored on the LDAP server are displayed.

**● If the Enter Network Password screen is displayed:**

- Specify each setting → press [OK].

The Enter Network Password screen is displayed if either one of the following is true:

- If <Login Information> in Register LDAP Server in System Settings (from the Additional Functions screen) is set to 'Use', and <Display authentication dialog when searching> is set to 'On'.
- If the user name, password, and domain name specified in Register LDAP Server in System Settings (from the Additional Functions screen) are incorrect.

[User]:

Press [User] → enter the user name → press [OK].

[Password]:

Press [Password] → enter the password → press [OK].

After pressing [OK], the password that you entered appears as asterisks (\*\*\*\*\*) on the Enter Network Password screen.

## 6 Select the destination that you want to store in the Address Book from the search results → press [Next].

To continue searching, press [Back].

You can select multiple destinations.

If you want to select the first 64 destinations, press [Select All (Max 64 destinations)]. (If a destination is selected, the key changes to [Clear Selection].)

E-mail addresses that meet the specified search criteria are displayed. You can register the selected e-mail address as an I-fax address by pressing [Register e-mail address for I-Fax]. To register e-mail addresses as I-fax addresses, register one e-mail address at a time.

If the optional Super G3 FAX Board or Super G3 Multi-Line FAX Board is installed, fax numbers that meet the specified search criteria are also displayed.

If the optional Super G3 FAX Board or Super G3 Multi-Line FAX Board is installed, you can restrict the type of destinations displayed in the results list by pressing the Type drop-down list.



### NOTE

To cancel a selected destination, select the destination again to clear the check mark.

## 7 Store the selected destination.



### IMPORTANT

The information that can be obtained via the LDAP server consists of only names and e-mail addresses, and fax numbers.

#### ● If only one destination is selected:

- Verify the address → press [OK].

If necessary, edit the contents of the address.

If the Access Number Management in Restrict the Send Function in System Settings (from the Additional Functions screen) is set to 'On', press [Next].

Press [Access Number].

Press [Access Number] → enter the access number using

⓪ - ⑨ (numeric keys).

Press [Confirm] → re-enter the access number for confirmation using

⓪ - ⑨ (numeric keys) → press [OK] → [OK].

If you do not want to set an access number for this address, press [OK] without entering any number.



**● If multiple destinations are selected:**

- Select the subaddress book in which to store the addresses → press [OK].

If the Access Number Management in Restrict the Send Function in System Settings (from the Additional Functions screen) is set to 'On', press [Access Number].

Press [Access Number] → enter the access number using

⓪ - ⑨ (numeric keys).

Press [Confirm] → re-enter the password for confirmation using

⓪ - ⑨ (numeric keys) → press [OK] → [OK].

If you do not want to set an access number for these addresses, press [OK] without entering any number.

- If you want to register a fax number or I-fax address as a new destination, read the displayed message → press [OK].

**NOTE**

The maximum number of destinations that can be selected at one time is 64.

**● If you want to register the selected destination as an I-fax address:**

- Verify the address → press [OK].

If necessary, edit the contents of the address.

If the Access Number Management in Restrict the Send Function in System Settings (from the Additional Functions screen) is set to 'On', press [Next].

Press [Access Number].

Press [Access Number] → enter the access number using

⓪ - ⑨ (numeric keys).

Press [Confirm] → re-enter the access number for confirmation using

⓪ - ⑨ (numeric keys) → press [OK] → [OK].

If you do not want to set an access number for this address, press [OK] without entering any number.

# Editing Address Details

You can change destination details as necessary.

**1** Press  (Additional Functions) → [Address Book Settings] → [Register Address].

**2** Select the destination to be changed → press [Edit].



Press the alphanumeric keys (e.g., [ABC]) to display the individual keys for each letter or number. You can select a letter or number to restrict the displayed range of entries. Press [All] to return to the full address list.

You can restrict the type of destinations displayed in the results list by pressing the Type drop-down list.

Press the Address Book drop-down list to display a list of subaddress books 1 to 10. Subaddress books categorize the addresses stored in the Address Book.

You cannot select a one-touch button stored in a subaddress book.

If you select [All] in the Address Book drop-down list, the destinations stored in the one-touch buttons are displayed. However, you cannot edit these destinations. For instructions on storing and editing one-touch buttons, see "Storing/Editing One-Touch Buttons," on p. 10-35.

If you select a destination that is stored with an access number, press [Access Number] and then enter the access number using  -  (numeric keys). If you press [No Access Number], the destinations that are not managed with an access number are displayed.



## NOTE

[Access Number] is displayed on the screen only if Access Number Management in Restrict the Send Function in System Settings (from the Additional Functions screen) is set to 'On'. (See "Access Number Management," on p. 11-16.)

**3** Edit the address details.

You cannot change the address book of a group address, or change a destination registered as a group address.

 **NOTE**

- For instructions on setting fax numbers, see "Fax Numbers," on p. 10-5.
- For instructions on setting e-mail addresses, see "E-Mail Addresses," on p. 10-9.
- For instructions on setting I-fax addresses, see "I-Fax Addresses," on p. 10-12.
- For instructions on setting file server addresses, see "File Server Addresses," on p. 10-17.
- For instructions on setting group addresses, see "Group Addresses," on p. 10-19.

## 4 Finish editing the address details.

### ● If Access Number Management is set to 'On':

- Press [Next].
- Press [Access Number].
- Press [Access Number] → enter the access number using 0 - 9 (numeric keys).
- Press [Confirm] → re-enter the access number for confirmation using 0 - 9 (numeric keys) → press [OK] → [OK].

If you do not want to set an access number for this e-mail address, press [OK] without entering any number.

You can enter up to seven digits for the access number. If you enter fewer than seven digits, the machine stores the access number with leading zeros.

Example: If <321> is entered, <0000321> is stored.

You cannot store an access number with only zeros as the number, such as <0000000>. If you enter a number that begins with zeros, the leading zeros are ignored.

Example: If <02> or <002> is entered, <0000002> is stored.

### ● If Access Number Management is set to 'Off':

- Press [OK].

 **NOTE**

- If you want to manage destinations with the Access Number Management mode, set the Access Number Management in Restrict the Send Function in System Settings (from the Additional Functions screen) to 'On'. (See "Access Number Management," on p. 11-16.)
- If there is any required destination setting that has not yet been set after registering the access number, the screen for specifying the destination settings is displayed again.
- If Use Asterisks to Enter Access No./Passwords in System Settings (from the Additional Functions screen) is set to 'Off' when Access Number Management in Restrict the Send Function in System Settings (from the Additional Functions screen) is set to 'On', the access number that you enter is not displayed as asterisks on the Access Number Settings screen. (See Chapter 6, "System Manager Settings," in the *Reference Guide*.)

# Erasing Addresses

You can erase destinations stored in the address book.

**1** Press  (Additional Functions) → [Address Book Settings] → [Register Address].

**2** Select the destination to be erased → press [Erase].

You cannot erase multiple destinations at the same time.



Press the alphanumeric keys (e.g., [ABC]) to display the individual keys for each letter or number. You can select a letter or number to restrict the displayed range of entries. Press [All] to return to the full address list.

You can restrict the type of destinations displayed in the results list by pressing the Type drop-down list.

Press the Address Book drop-down list to display a list of subaddress books 1 to 10. Subaddress books categorize the addresses stored in the Address Book.

You cannot select a one-touch button stored in a subaddress book.

If you select [All] in the Address Book drop-down list, the destinations stored in the one-touch buttons are displayed. However, you cannot erase these destinations. For instructions on erasing one-touch buttons, see "Erasing One-Touch Buttons," on p. 10-39.

If you select a destination that is stored with an access number, press [Access Number] and then enter the access number using  -  (numeric keys). If you press [No Access Number], the destinations that are not managed with an access number are displayed.



## NOTE

[Access Number] is displayed on the screen only if Access Number Management in Restrict the Send Function in System Settings (from the Additional Functions screen) is set to 'On'. (See "Access Number Management," on p. 11-16.)

**3** Press [Yes].

# Naming an Address Book

---

You can assign a name to any subaddress book.

---

- 1** Press  (Additional Functions) → [Address Book Settings] → [Register Address Book Name].
- 2** Select a subaddress book to name → press [Register Name].
- 3** Enter a name → press [OK].



#### NOTE

If you press [OK] without entering any characters, the subaddress book name reverts to its current name (default Address Book 1 to 10).

- 4** Press [OK].

# Storing/Editing One-Touch Buttons

You can store up to 200 destinations in the one-touch buttons. This section describes how to store/edit the destinations with the one-touch buttons feature.

## IMPORTANT

If Language Switch in Common Settings (from the Additional Functions screen) is set to 'On', the Host Name and File Path of the file server destination may not be displayed correctly, so you may not be able to refer to them.



## NOTE

- Destinations stored in one-touch buttons are also displayed in the Address Book.
- A new destination cannot be registered in a group destination that is stored in a one-touch button. The destination must be registered in a one-touch button in advance.
- E-mail addresses, I-fax addresses, file server addresses, and group addresses can be stored in a one-touch button.
- If the optional Super G3 FAX Board or Super G3 Multi-Line FAX Board is installed, fax numbers in addition to the above mentioned destinations can be stored.

**1** Press  (Additional Functions) → [Address Book Settings] → [One-touch Buttons].

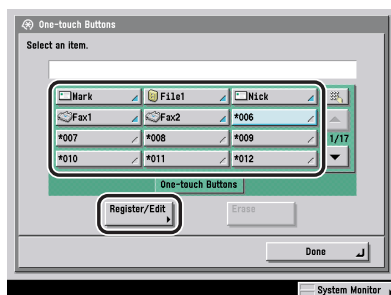
**2** Select a one-touch button to store or change → press [Register/Edit].



If you know the one-touch button's three digit number, press  (One-Touch Button Number) → enter the three digit number of the desired one-touch button using  -  (numeric keys).

If you select a one-touch button already storing a destination, proceed to step 4.

 NOTE

- One-touch buttons that already have destinations stored in them are displayed with a colored triangle () in the lower right corner of the key.
- If you select a one-touch button that already has destinations stored in it, the destinations are displayed.
- If you register multiple destinations as a group address in a one-touch button, the number of destinations registered in the group address is displayed.

### 3 Select [Fax], [E-mail], [I-Fax], [File], [Group], or [Network Add. Book].

● **If you select [Fax] (The optional Super G3 FAX Board or Super G3 Multi-Line FAX Board is installed):**

- Enter a name for the recipient of the fax in accordance with steps 4 and 5 of "Fax Numbers," on p. 10-5.
- Press [One-touch Button Name].
- Enter a name for the one-touch button → press [OK].
- Enter the fax number of the destination in accordance with step 7 of "Fax Numbers," on p. 10-5.

● **If you select [E-mail]:**

- Enter a name for the e-mail address in accordance with steps 3 and 4 of "E-Mail Addresses," on p. 10-9.
- Press [One-touch Button Name].
- Enter a name for the one-touch button → press [OK].
- Specify the e-mail address and Divided Data Destination setting in accordance with steps 6 and 7 of "E-Mail Addresses," on p. 10-9.

● **If you select [I-Fax]:**

- Enter a name for the I-fax address in accordance with steps 3 and 4 of "I-Fax Addresses," on p. 10-12.
- Press [One-touch Button Name].
- Enter a name for the one-touch button → press [OK].
- Specify the I-fax mode, I-fax address, standard fields, send via server setting, or destination condition in accordance with steps 6 to 11 of "I-Fax Addresses," on p. 10-12.



**● If you select [File]:**

- Enter a name for the file server address in accordance with steps 3 and 4 of "File Server Addresses," on p. 10-17.
- Press [One-touch Button Name].
- Enter a name for the one-touch-button → press [OK].
- Specify the protocol, host name, file path, user, and password in accordance with steps 6 and 7 of "File Server Addresses," on p. 10-17.

**● If you select [Group]:**

- Enter a name for the group address in accordance with steps 3 and 4 of "Group Addresses," on p. 10-19.
- Press [One-touch Button Name].
- Enter a name for the one-touch button → press [OK].
- Press [Specifying Destinations].
- Select a destination to store in the group address from [Address Book], the one-touch buttons, or [Store In Usr Inbox] → press [OK].

Only destinations that are already stored in one-touch buttons can be selected as part of a one-touch button group address.

If you know the one-touch button's three digit number, press [ ] (One-Touch Button Number) → enter the three digit number of the desired one-touch button using [0] - [9] (numeric keys).

**● If you select [Network Add. Book]:**

- Search destinations in accordance with steps 3 to 4 of "Addresses Obtained via a Server," on p. 10-23.
- Select the destination that you want to store in the one-touch button from the search results → press [Next].

To continue searching, press [Back].

You cannot select multiple destinations at the same time.

E-mail addresses that meet the specified search criteria are displayed. You can register the selected e-mail address as an I-fax address by pressing [Register e-mail address for I-Fax]. To register e-mail addresses as I-fax addresses, register one e-mail address at a time.

If the optional Super G3 FAX Board or Super G3 Multi-Line FAX Board is installed, fax numbers that meet the specified search criteria are also displayed.

If the optional Super G3 FAX Board or Super G3 Multi-Line FAX Board is installed, you can restrict the type of destinations displayed in the results list by pressing the Type drop-down list.

 **NOTE**

To cancel a selected destination, select the destination again.

- If necessary, edit the contents of the destination.
- Press [One-touch Button Name] → enter a name for the one-touch button → press [OK].

 **IMPORTANT**

The information that can be obtained via the LDAP server consists of only names, e-mail addresses, and fax numbers.

**4** Press [OK].

# Erasing One-Touch Buttons

You can erase the destinations that you have stored in one-touch buttons.

- 1 Press **Ⓞ** (Additional Functions) → [Address Book Settings] → [One-touch Buttons].
- 2 Select the one-touch button containing the destination(s) you want to erase → press [Erase].

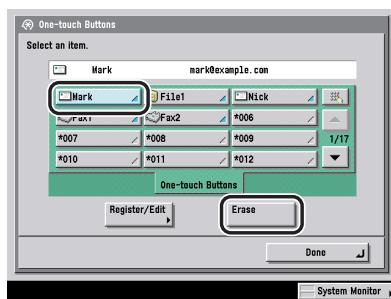

If you know the one-touch button's three digit number, press **[#]** (One-Touch Button Number) → enter the three digit number of the desired one-touch button using **Ⓞ** - **Ⓣ** (numeric keys).

## **Ⓜ** IMPORTANT

Make sure that you verify the settings first before you erase them.

## **✎** NOTE

- One-touch buttons that already have destinations stored in them are displayed with a colored triangle (▲) in the lower right corner of the key.
- If you select a one-touch button that already has destinations stored in it, the destinations are displayed.

## 3 Press [Yes].



# System Manager Settings

This chapter describes the settings that can be made by the System Manager (the person in charge of the machine).

---

System Settings Table .....	11-2
Communications Settings .....	11-4
E-Mail/I-Fax Settings .....	11-4
Fax Settings .....	11-7
Memory RX Inbox Settings .....	11-9
Restricting Send Function .....	11-15
Address Book Password .....	11-15
Access Number Management .....	11-16
Restricting New Addresses .....	11-16
Setting Whether to Allow Sending Using the Fax Driver .....	11-17
Setting to Confirm Entered Fax Numbers .....	11-18
Restricting the Domains to Which E-mail/I-Fax Documents Can Be Sent .....	11-19
Allowing the Sending of PDF Documents With Expired Certificates .....	11-20
Setting to Always Add a Device Signature to PDF Documents .....	11-21
Forwarding Settings .....	11-22
Storing Forwarding Settings .....	11-23
When Forwarding Destinations Do Not Match the Forwarding Conditions .....	11-35
Checking/Changing Forwarding Settings .....	11-40
Forwarding Received Documents .....	11-41
Erasing Forwarding Settings .....	11-41
Printing Forwarding Settings .....	11-42
LDAP Server Settings .....	11-43
Registering an LDAP Server .....	11-43
Changing an LDAP Server Setting .....	11-48
Deleting an LDAP Server .....	11-48
Registering/Editing LDAP Search Attributes .....	11-49
Printing LDAP Server Settings .....	11-50

# System Settings Table

The following items can be stored or set in System Settings from the Additional Functions screen.

## ■ System Settings

Item	Settings	Delivered	Applicable Page	
<b>Communications Settings</b>				
E-mail/I-Fax Settings				
Maximum Data Size for Sending	0 (Off), 1 to 99 MB; 3 MB <sup>*1</sup>	Yes	p. 11-4	
Full Mode TX Timeout	1 to 99 hours; 24 hours <sup>*1</sup>	Yes		
Divided Data RX Timeout	0 to 99 hours; 24 hours <sup>*1</sup>	Yes		
Default Subject	40 characters maximum; Attached Image <sup>*1</sup>	Yes		
Print MDN/DSN on Receipt	On, Off <sup>*1</sup>	Yes		
Always send notice for RX errors	On <sup>*1</sup> , Off	Yes		
Use Send Via Server	On, Off <sup>*1</sup>	Yes		
Allow MDN Not Via Server	On <sup>*1</sup> , Off	Yes		
Fax Settings <sup>*2</sup>				
Send Start Speed	33600 bps <sup>*1</sup> , 14400 bps, 9600 bps, 7200 bps, 4800 bps, 2400 bps	Yes		p. 11-7
Receive Start Speed	33600 bps <sup>*1</sup> , 14400 bps, 9600 bps, 7200 bps, 4800 bps, 2400 bps	Yes		
Receive Password	20 digits maximum	No		
PIN Code Access	On, Off <sup>*1</sup>	Yes		
Memory RX Inbox Settings				
Memory RX Inbox Password	Seven digits maximum	No	p. 11-9	
Use Fax Memory Lock <sup>*2</sup>	On, Off <sup>*1</sup>	Yes		
Use I-Fax Memory Lock	On, Off <sup>*1</sup>	Yes		
Memory Lock Start Time	Everyday, Select Days, Off <sup>*1</sup>	Yes		
Memory Lock End Time	Everyday, Select Days, Off <sup>*1</sup>	Yes		

Item	Settings	Delivered	Applicable Page
<b>Restrict the Send Function</b>			
Address Book Password	Seven digits maximum	Yes	p. 11-15
Access Number Management	On, Off <sup>*1</sup>	Yes	p. 11-16
Restrict New Addresses	Fax: On, Off <sup>*1</sup> E-mail: On, Off <sup>*1</sup> I-Fax: On, Off <sup>*1</sup> File: On, Off <sup>*1</sup>	Yes	p. 11-16
Allow Fax Driver TX <sup>*2</sup>	On <sup>*1</sup> , Off	Yes	p. 11-17
Confirm Entered Fax Numbers <sup>*2</sup>	On, Off <sup>*1</sup>	Yes	p. 11-18
E-mail/I-Fax Domain Sending Restriction	Restrict Sending to Domains: On Register, Edit, Erase <sup>*5</sup> Off <sup>*1</sup>	Yes	p. 11-19
Allow PDF Send with Expired Certificates <sup>*3</sup>	On, Off <sup>*1</sup>	Yes	p. 11-20
Always Add Device Signature to Send PDF <sup>*4</sup>	On, Off <sup>*1</sup>	Yes	p. 11-21
<b>Forwarding Settings</b>	Receive Type <sup>*5</sup> , Validate/Invalidate, Register, Edit <sup>*5</sup> , Erase <sup>*5</sup> , Forward w/o Conditions, Print List <sup>*5</sup> , E-mail Priority <sup>*5</sup>	Yes	p. 11-22
<b>Register LDAP Server</b>	Register, Edit, Erase, Register/Edit LDAP Search, Print List	No	p. 11-43

\*1 Indicates the default setting.

\*2 Indicates item that appears only if the optional Super G3 FAX Board or Super G3 Multi-Line Fax Board is installed.

\*3 Indicates item that appears only if the optional Universal Send PDF Security Feature Set or the optional Digital User Signature PDF Kit is activated.

\*4 Indicates item that appears only if the optional Universal Send PDF Security Feature Set is activated.

\*5 Indicates item that is not delivered as device information.

### NOTE

- For instructions on setting the modes not described in this manual, refer to the other manuals listed in "Manuals for the Machine," on p. ii.
- The System Settings screen consists of a list of individual settings. Press [▼] or [▲] to scroll to the desired setting.
- Information that is delivered when the Device Information Delivery Settings mode is set, is marked with "Yes" in the "Delivered" column. For instructions on setting the Device Information Delivery Settings mode, see Chapter 6, System Manager Settings, in the *Reference Guide*.

# Communications Settings

This section describes the e-mail, I-fax, fax, and Memory RX Inbox settings.

## E-Mail/I-Fax Settings

You can change the e-mail and I-fax transmission settings. The following settings are available.

### ■ Maximum Data Size for Sending

Sets the maximum data size for outgoing e-mail messages and I-fax documents. If an e-mail message exceeds this data size limit, it is split up into several e-mail messages before being sent. However, if an I-fax transmission exceeds the data size limit, it is handled as an error, and it is not sent.

#### IMPORTANT

When sending an e-mail or I-fax document, you can set to divide the data before sending it if the size of the data exceeds the maximum data size for sending.

#### NOTE

For information on dividing data before sending it, see "Specifying Destinations Using the New Address Tab," on p. 2-2, and "Storing New Addresses," on p. 10-5.

### ■ Full Mode TX Timeout

Sets the time that elapses before sending operations terminate (automatically) if you do not receive a notification e-mail message (MDN) from the recipient when you send an I-fax in the Full Mode.

### ■ Divided Data RX Timeout

If it takes longer than the set Divided Data RX Timeout time to receive all the parts of a divided I-fax document, only the data which has been received is combined to form the document. Data which can be combined to form complete pages is printed, and any remaining data is erased.

#### IMPORTANT

- If you delete the divided data, it cannot be combined to form a document even if the remaining divided data is received later.
- Divided data cannot be printed as a regular image unless it has been combined.
- If you select [Print When Erased] on the Divided Data RX Inbox screen for the Mail Box function to print the data which is erased, the data will not be forwarded or stored in memory. It will only be printed.



## ■ Default Subject

The subject that you enter here is used as the default subject whenever you do not enter a subject when sending a job.

## ■ Print MDN/DSN on Receipt

Sets whether to print notification e-mail messages that inform you of the successful delivery of I-fax jobs sent using the Full Mode.

## ■ Always Send Notice for RX Errors

Sets whether to inform the sender that the e-mail message or I-fax was not received successfully.

## ■ Use Send Via Server

Determines whether you can select to send jobs via a server on the screen for specifying I-fax destination settings. To be able to select 'On' or 'Off' for <Send Via Server> in E-mail/I-Fax Settings in Communications Settings in System Settings (from the Additional Function screen), set <Use Send Via Server> and <Allow Not Via Server> to 'On' beforehand.

## ■ Allow MDN Not Via Server

Sets whether to allow the recipient machine to send MDN (Mail Delivery Notification) mail directly to the IP address of the sending machine without going via a mail server.

**1** Press  (Additional Functions) → [System Settings] → [Communications Settings] → [E-mail/I-Fax Settings].

**2** Specify each setting → press [OK].

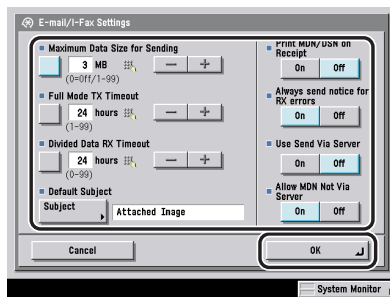

<Maximum Data Size for Sending>:

Specify the maximum data size for sending by pressing [-] or [+].

<Full Mode TX Timeout>:

Specify the full mode TX timeout time by pressing [-] or [+].

<Divided Data RX Timeout>:

Specify the divided data TX timeout time by pressing [-] or [+].

<Subject>:

Press [Subject] → enter a subject → press [OK].

<Print MDN/DSN on Receipt>:

[On]: Notification e-mail messages (MDN/DSN) that inform you of the successful delivery of jobs are printed.

[Off]: Notification e-mail messages (MDN/DSN) that inform you of the successful delivery of jobs are not printed.

<Always send notice for RX errors>:

[On]: If an error occurs, the sender is always informed of the details of the error.

[Off]: If an error occurs, the sender is not informed of the details of the error.

<Use Send Via Server>:

[On]: Enables you to set whether to use the Send Via Server setting as a condition to send to I-fax addresses.

[Off]: You cannot use the Send Via Server setting as a condition to send to I-fax addresses.

<Allow MDN Not Via Server>:

[On]: Allows the sending of MDN (Mail Delivery Notification) mail without going via a mail server.

[Off]: Does not allow the sending of MDN (Mail Delivery Notification) mail without going via a mail server.



### IMPORTANT

The maximum data size for sending must not be greater than the maximum data size of the mail server.



### NOTE

- If you enter '0' MB as the data size, there is no size limit on the data that is sent.
- If you set the divided data RX timeout time to '0', no divided data RX timeout time is set.
- For I-fax, when <Send Via Server> is set to 'Off', even if you enter the maximum data size for sending, there is no size limit on the data that is sent.
- The maximum data size for sending can be set in 1 MB increments. If the size of an e-mail exceeds the set limit, the e-mail message is split up by page and sent out as smaller e-mail messages, each of which is within the set limit. I-fax data that exceeds the set limit is handled as an error, and is not sent. For more information, contact your local authorized Canon dealer.

# Fax Settings

This section describes settings that the System Manager can make, including how to set the Send Start Speed, Receive Start Speed, RX (Receive) mode, and how to register a password. It also describes how to set, change, and erase settings for transferring received documents, and how to enable or disable certain settings.

 **NOTE**

This mode is available only if the optional Super G3 FAX Board or Super G3 Multi-Line Fax Board is installed.

■ **Send/Receive Start Speed**

This function enables you to change the send and receive start speeds, which is useful when there is difficulty initiating the sending or receiving of a document.

■ **Reception Password**

This function enables you to set an optional ITU-T standard password. If a subaddress is not set in a document that was received from another party using the ITU-T standard, an RX password check takes place. If the RX password found does not match the RX password set with this mode, or if an RX password is not attached to the document, the document is not received.

 **NOTE**

ITU-T stands for International Telecommunication Union-Telecommunication Standardization Sector, which is the group that makes recommendations towards the standardization of worldwide telecommunications.

---

**1** Press  (Additional Functions) → [System Settings] → [Communications Settings] → [Fax Settings].

## 2 Specify each setting → press [OK].

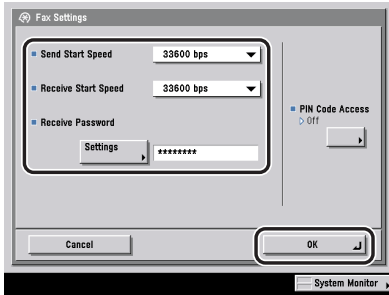

<Send Start Speed>:

Press the Send Start Speed drop-down list → select the desired start speed.

If your document transmission is slow in starting, this may mean that the telephone lines in your area are in poor condition. Select a slower speed. You can select [33600 bps], [14400 bps], [9600 bps], [7200 bps], [4800 bps], or [2400 bps].

<Receive Start Speed>:

Press the Receive Start Speed drop-down list → select the desired start speed.

If your document reception is slow in starting, this may mean that the telephone lines in your area are in poor condition. Select a slower speed. You can select [33600 bps], [14400 bps], [9600 bps], [7200 bps], [4800 bps], or [2400 bps].

<Receive Password>:

Press [Settings] → enter [Password] and [Confirm] using  $\odot$  -  $\odot$  (numeric keys),  $\oplus$ , and  $\ominus$ .

Press [Space] to insert a space.

Press [Backspace] to delete the last digit that you entered.

### IMPORTANT

Priority is given to a subaddress password if the received document is set with a subaddress, even if a receive password is set.

### NOTE

- If Use Asterisks to Enter Access No./Passwords in System Settings (from the Additional Functions screen) is set to 'Off', the password that you entered is not displayed as asterisks. (See Chapter 6, "System Manager Settings," in the *Reference Guide*.)
- For instructions on setting a PIN Code, see "Using a PIN Code," on p. 7-5.

# Memory RX Inbox Settings

There may be occasions when you want to store all incoming documents into memory until you are ready to print or send them. Locking the machine to receive and store all documents in memory is called Memory Lock. After Memory Lock is turned 'On', the machine will enter the Memory Lock mode. Documents received when the machine is in the Memory Lock mode are stored in memory until you unlock the memory with a password, and print or send them.

This section explains how to define a memory lock password, receive fax/I-fax documents in memory, and set the times for the machine to enter and leave the Memory Lock mode.

## NOTE

If the optional Super G3 FAX Board or Super G3 Multi-Line Fax Board is installed, you can receive faxes in addition to the I-faxes into memory.



## *Setting the Memory RX Inbox Password*

You can set a seven digit password for the Memory RX (Receive) Inbox, and restrict its use to only those users who know the password.

## NOTE

You can enter up to seven digits for the password. If you enter fewer than seven digits, the machine stores the password with leading zeros.

- Example: If <321> is entered, <0000321> is stored.

- 
- 1** Press  (Additional Functions) → [System Settings] → [Communications Settings] → [Memory RX Inbox Settings] → [Memory RX Inbox Password].
  - 2** Press [Settings].
  - 3** Press [Password] → enter the desired password using  -  (numeric keys).

## 4 Press [Confirm] → re-enter the password for confirmation using 0 - 9 (numeric keys) → press [OK] → [OK].

If you do not want to set the Memory RX Inbox with a password, press [OK] without entering any numbers.

You cannot store a password with only zeros as the number, such as <0000000>.

If you enter a number that begins with zeros, the leading zeros are ignored.

Example: If <02> or <002> is entered, <0000002> is stored.



### NOTE

If Use Asterisks to Enter Access No./Passwords in System Settings (from the Additional Functions screen) is set to 'Off', the password that you entered is not displayed as asterisks. (See Chapter 6, "System Manager Settings," in the *Reference Guide*.)

## Storing Received Fax Documents in Memory

You can set the machine to store received fax documents in memory without printing them. This is referred to as Fax Memory Lock. You can later check the received documents in the Memory RX Inbox, and print or send them.

---

### 1 Press (Additional Functions) → [System Settings] → [Communications Settings] → [Memory RX Inbox Settings] → [Use Fax Memory Lock].

### 2 Select [On] or [Off] → press [OK].



### IMPORTANT

If the message <Fax Memory RX is on.> does not appear, set the Fax Memory Lock setting on the Memory RX Inbox screen from the Inbox Selection screen of the Mail Box function to 'On'. (See Chapter 6, "Sending and Receiving Documents Using the Inboxes," in the *Copying and Mail Box Guide*.)

## Storing Received I-Fax Documents in Memory

You can set the machine to store received I-fax documents in memory without printing them. This is referred to as I-Fax Memory Lock. You can later check the received documents in the Memory RX Inbox, and print or send them.

---

- 1** Press  (Additional Functions) → [System Settings] → [Communications Settings] → [Memory RX Inbox Settings] → [Use I-Fax Memory Lock].
- 2** Select [On] or [Off] → press [OK].



### IMPORTANT

If the message <I-Fax Memory RX is on.> does not appear, set the I-Fax Memory Lock setting on the Memory RX Inbox screen from the Inbox Selection screen of the Mail Box function to 'On'. (See Chapter 6, "Sending and Receiving Documents Using the Inboxes," in the *Copying and Mail Box Guide*.)

## Memory Lock Start Time Settings

You can set Memory Lock to start automatically at a specified time.

---

- 1** Press  (Additional Functions) → [System Settings] → [Communications Settings] → [Memory RX Inbox Settings] → [Memory Lock Start Time].

## 2 Select [Everyday], [Select Days], or [Off].

### ● If you select [Everyday]:

- Select a number ([1] to [5]) → enter the start time using  $\odot$  -  $\odot$  (numeric keys) → press [OK].

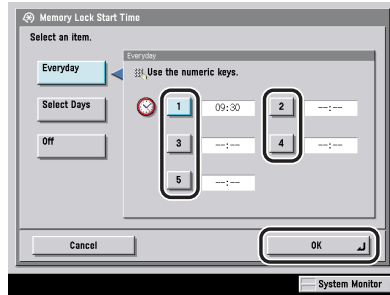

You can store up to five different start times.

Enter all four digits of the time (including zeros), using 24-hour notation.

Examples: 7:05 a.m. → 0705

11:18 p.m. → 2318

If you make a mistake when entering the time, press  $\odot$  (Clear) to clear your entry → enter another four digit number.

### ● If you select [Select Days]:

- Select a day of the week ([Sun] to [Sat]) → select a number ([1] to [5]).

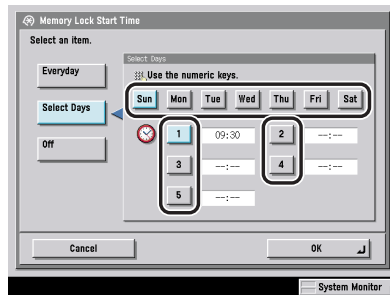

- Enter the start time using  $\odot$  -  $\odot$  (numeric keys) → press [OK].

You can store up to five different start times for each day of the week.

Enter all four digits of the time (including zeros), using 24-hour notation.

Examples: 7:05 a.m. → 0705

11:18 p.m. → 2318

If you make a mistake when entering the time, press  $\odot$  (Clear) to clear your entry → enter another four digit number.



● **If you select [Off]:**

- Press [OK].

If you select [Off], Memory Lock will not automatically turn on at a specified time. You can manually turn Memory Lock On or Off by pressing [On] or [Off] under <Fax Memory Lock> or <I-Fax Memory Lock> on the Memory RX Inbox screen from the Inbox Selection screen of the Mail Box function. (See Chapter 6, "Sending and Receiving Documents Using the Inboxes," in the *Copying and Mail Box Guide*.)

 **NOTE**

You can select [Everyday] for Memory Lock Start Time, and [Select Days] for Memory Lock End Time, and vice versa.



## **Memory Lock End Time Settings**

You can set Memory Lock to end automatically at a specified time.

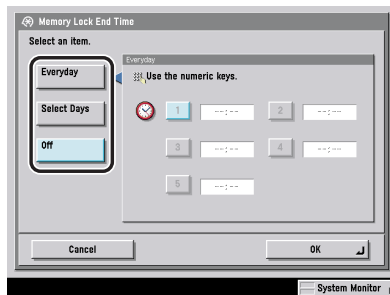
- 1** Press  (Additional Functions) → [System Settings] → [Communications Settings] → [Memory RX Inbox Settings] → [Memory Lock End Time].
- 2** Select [Everyday], [Select Days], or [Off].



● **If you select [Everyday]:**

- Select a number ([1] to [5]) → enter the end time using  -  (numeric keys) → press [OK].

You can store up to five different end times.

Enter all four digits of the time (including zeros), using 24-hour notation.



Examples: 7:05 a.m. → 0705

11:18 p.m. → 2318

If you make a mistake when entering the time, press  (Clear) to clear your entry → enter another four digit number.

● **If you select [Select Days]:**

Select a day of the week ([Sun] to [Sat]) → select a number ([1] to [5]).

Enter the end time using  -  (numeric keys) → press [OK].

You can store up to five different end times for each day of the week.

Enter all four digits of the time (including zeros), using 24-hour notation.

Examples: 7:05 a.m. → 0705

11:18 p.m. → 2318

If you make a mistake when entering the time, press  (Clear) to clear your entry → enter another four digit number.

● **If you select [Off]:**

Press [OK].

If you select [Off], Memory Lock will not automatically turn off at a specified time. You can manually turn Memory Lock On or Off by pressing [On] or [Off] under <Fax Memory Lock> or <I-Fax Memory Lock> on the Memory RX Inbox screen from the Inbox Selection screen of the Mail Box function. (See Chapter 6, "Sending and Receiving Documents Using the Inboxes," in the *Copying and Mail Box Guide*.)



**NOTE**

You can select [Everyday] for Memory Lock Start Time, and [Select Days] for Memory Lock End Time, and vice versa.

# Restricting Send Function

You can set the Address Book with a password and set access numbers to restrict its use.

## Address Book Password

You can set a password for the Address Book. If a password is set, restrictions can be placed on the registering, editing, and erasing of destinations.

### NOTE

You can enter up to seven digits for the Address Book password. If you enter fewer than seven digits, the machine stores the password with leading zeros.

- Example: If <321> is entered, <0000321> is stored.

- 1** Press **Ⓜ** (Additional Functions) → [System Settings] → [Restrict the Send Function] → [Address Book Password].
- 2** Press [Settings].
- 3** Press [Password] → enter the desired password using **⓪** - **⑨** (numeric keys).
- 4** Press [Confirm] → re-enter the password for confirmation using **⓪** - **⑨** (numeric keys) → press [OK] → [OK].

If you do not want to set the Address Book with a password, press [OK] without entering any numbers.

You cannot store a password with only zeros as the number, such as <0000000>. If you enter a number that begins with zeros, the leading zeros are ignored.

Example: If <02> or <002> is entered, <0000002> is stored.

### NOTE

If Use Asterisks to Enter Access No./Passwords in System Settings (from the Additional Functions screen) is set to 'Off', the password that you entered is not displayed as asterisks. (See Chapter 6, "System Manager Settings," in the *Reference Guide*.)

# Access Number Management

You can set an access number for an address in the Address Book to restrict access to that address, and this restricts other users who do not know the access number from viewing and utilizing these special addresses.

**1** Press  (Additional Functions) → [System Settings] → [Restrict the Send Function] → [Access Number Management].

**2** Select [On] or [Off] → press [OK].

If Access Number Management is set to 'On', the Recall mode cannot be used.

# Restricting New Addresses

This mode enables you to restrict users from adding new destinations (fax, e-mail, I-fax, or file) to send to. The four types of new destinations can be restricted independently. The destination types you set to 'On' are grayed out so that they cannot be selected in [New Address] on the Send Basic Features screen. Setting this mode with an address book password enables only the following to be specified as destinations for the destination types in Restrict New Addresses set to 'On'.

- Destinations stored in the Address Book
- Destinations obtained via LDAP servers
- User Inboxes
- Destinations obtained by pressing one-touch buttons
- Destinations obtained by pressing favorites buttons
- E-mail addresses obtained by pressing [Send to Myself]

## IMPORTANT

- The following destinations cannot be edited if a destination type in Restrict New Addresses is set to 'On':
  - Destinations obtained via LDAP servers
  - Destinations obtained by pressing favorites buttons
  - E-mail addresses obtained by pressing [Send to Myself]
  - Destinations of a job that is canceled because of transmission errors, or a job that is waiting to be sent with the Delayed Send mode
- If a destination type in Restrict New Addresses is set to 'On', all stored settings in the Recall mode are erased, regardless of the destination type.

- 
- 1** Press  (Additional Functions) → [System Manager Settings] → [Restrict the Send Function] → [Restrict New Addresses].
  - 2** Select [Fax], [E-mail], [I-Fax], or [File].
  - 3** Select [On] or [Off] → press [OK].

## Setting Whether to Allow Sending Using the Fax Driver

You can set whether to disable the sending of faxes using the fax driver.

 **NOTE**

This mode is available only if the optional Super G3 FAX Board or Super G3 Multi-Line Fax Board is installed.

- 
- 1** Press  (Additional Functions) → [System Settings] → [Restrict the Send Function] → [Allow Fax Driver TX].
  - 2** Select [On] or [Off] → press [OK].

Details of each item are shown below.

[On]: Faxes can be sent using the fax driver.

[Off]: Faxes cannot be sent using the fax driver.

## Setting to Confirm Entered Fax Numbers

This mode displays a confirmation screen when a user enters a fax number, to prevent misdialing.

 **NOTE**

This mode is available only if the optional Super G3 FAX Board or Super G3 Multi-Line Fax Board is installed.

---

**1** Press  (**Additional Functions**) → **[System Settings]** → **[Restrict the Send Function]** → **[Confirm Entered Fax Number]**.

**2** Select **[On]** or **[Off]** → press **[OK]**.

Details of each item are shown below.

[On]: Displays a confirmation screen after a fax number is entered.

[Off]: Does not display a confirmation screen after a fax number is entered.

# Restricting the Domains to Which E-mail/I-Fax Documents Can Be Sent

You can restrict the domains to which documents can be sent via e-mail or I-fax. If you restrict the domains for sending, you can send documents only to destinations which belong the specified domain.

**1** Press **Ⓜ** (Additional Functions) → [System Settings] → [Restrict the Send Function] → [E-mail/I-Fax Domain Sending Restriction].

**2** Select [On] for <Restrict Sending to Domains>.

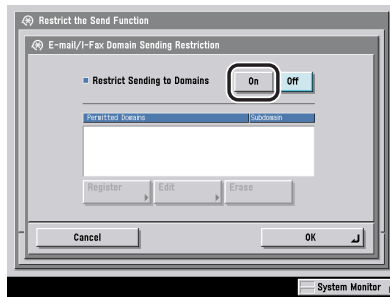

If you select [Off], proceed to step 4.

**3** Specify the domains to which you want to allow e-mail or I-fax documents to be sent.

● **If you want to register a domain:**

- Press [Register].
- Press [Domain Name] → enter a domain name → press [OK].
- Select [Permit] or [Reject] for <Send to Subdomain> → press [OK].  
<Send to Subdomain>:  
[Permit]: Allow sending to subdomains of the domain.  
[Reject]: Do not allow sending to subdomains of the domain.



**NOTE**

You can register up to three domains.

● **If you want to edit a domain:**

- Select the desired registered domain → press [Edit].
- Press [Domain Name] → edit the domain name → press [OK].
- Select [Permit] or [Reject] for <Send to Subdomain> → press [OK].  
    <Send to Subdomain>:  
    [Permit]: Allow sending to subdomains of the domain.  
    [Reject]: Do not allow sending to subdomains of the domain.

● **If you want to erase a domain:**

- Select the domain that you want to erase → press [Erase].
- Press [Yes].

## 4 Press [OK].

# Allowing the Sending of PDF Documents With Expired Certificates

This mode enables you to set whether to allow the sending of PDF documents created with expired certificates.

 **NOTE**

This mode is available only if the optional Universal Send PDF Security Feature Set or the optional Digital User Signature PDF Kit is activated.

---

## 1 Press (Additional Functions) → [System Settings] → [Restrict the Send Function] → [Allow PDF Send with Expired Certificates].

## 2 Select [On] or [Off] → press [OK].

Details of each item are shown below.

[On]: Allows the sending of PDF documents created with expired certificates.

[Off]: Does not allow the sending of PDF documents created with expired certificates.



# Setting to Always Add a Device Signature to PDF Documents

This mode enables you to set whether to always add a device signature to sent PDF documents.

 **NOTE**

This mode is available only if the optional Universal Send PDF Security Feature Set is activated.

---

**1** Press  (**Additional Functions**) → **[System Settings]** → **[Restrict the Send Function]** → **[Always Add Device Signature to Send PDF]**.

**2** Select **[On]** or **[Off]** → press **[OK]**.

Details of each item are shown below.

[On]: Always adds a device signature to sent PDF documents.

[Off]: Does not add a device signature to sent PDF documents.

# Forwarding Settings

You can set the machine to store received fax/I-fax documents in Confidential Fax Inboxes, or forward them to other machines or file servers. If a received document matches the forwarding conditions, it is forwarded to the specified destination. You can also set a specified time during which received fax/I-fax documents which match the forwarding conditions are forwarded. This section explains the conditions for forwarding, and how to register, change, and erase forwarding destinations.

When the Machine receives I-fax/Fax documents, they are processed as shown below:

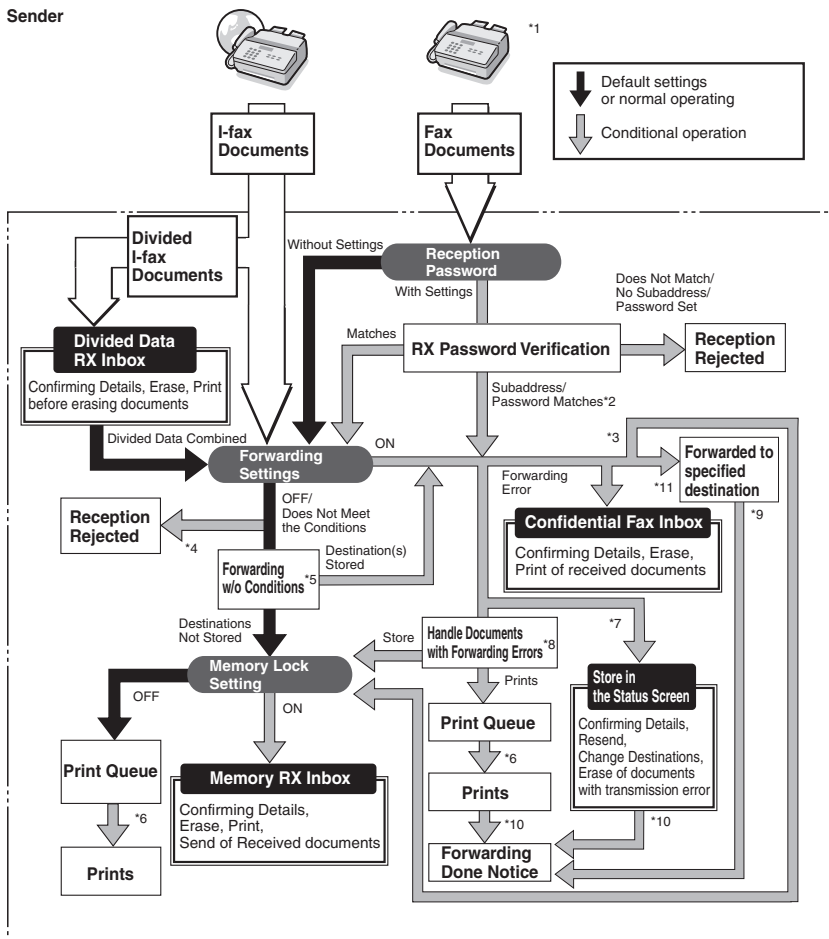

- \*1 Received fax documents can be forwarded if the optional Super G3 FAX Board or Super G3 Multi-Line Fax Board is installed.
- \*2 If the subaddress and password attached to the received document match the information registered in Forwarding Settings in System Settings (from the Additional Functions screen), the documents are forwarded to their forwarding destinations regardless of the reception password setting.
- \*3 If Store/Print Received Doc. in Forwarding Settings in System Settings (from the Additional Functions screen) is set to 'On', forwarded documents are either printed or stored in the Memory RX Inbox.
- \*4 If the subaddress and password attached to the received document do not match the information registered in Forwarding Settings in System Settings (from the Additional Functions screen), the document is rejected.
- \*5 If Forward w/o Conditions is set up in Forwarding Settings in System Settings (from the Additional Functions screen), all received documents that do not match the specified forwarding conditions are forwarded to the destination selected for Forward w/o Conditions.
- \*6 If documents are received while paper is jammed, or paper or toner has run out, it is printed after the paper jam is cleared, paper is loaded, or toner is added.
- \*7 If Erase Failed TX in TX Settings under <Common Settings> in Communications Settings (from the Additional Functions screen) is set to 'Off', the status of any job with a forwarding error will be saved on the System Monitor screen.
- \*8 Documents with forwarding errors are handled as follows, depending on the settings for Handle Documents with Forwarding Errors in TX Settings under <Common Settings> in Communications Settings (from the Additional Functions screen):
  - [Always Print]: All documents with forwarding errors are printed.
  - [Store/Print]: Documents with forwarding errors are stored in the Memory RX Inbox when Memory Lock is turned 'On'. If Memory Lock is turned 'Off', the documents are printed.
- \*9 If the Forwarding Done Notice is specified in Forwarding Settings in System Settings (from the Additional Functions screen), a notification e-mail is sent when the forwarding job completes successfully.
- \*10 If the Forwarding Done Notice is specified in Forwarding Settings in System Settings (from the Additional Functions screen), a notification e-mail is sent when the forwarding job completes successfully. However, if <Notice Only for Errors> is also specified, a notification e-mail is sent only when the document fails to be forwarded.
- \*11 The received Fax/I-fax documents can be stored in the Confidential Fax Inbox by specifying the Confidential Fax Inbox as forwarding destination. Only the received documents that match the specified forwarding conditions can be stored in the Confidential Fax Inbox.

 **NOTE**

The maximum number of forwarding settings that you can store is 150.

## Storing Forwarding Settings

- 1** Press  (Additional Functions) → [System Settings] → [Forwarding Settings].

## 2 Press [Register].

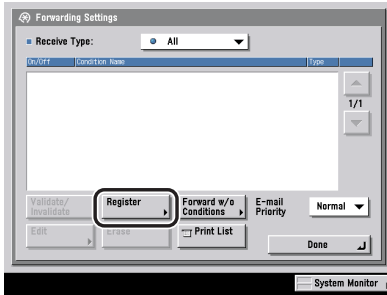

## 3 To recall the forwarding settings of a received document that you have stored, press [1 Before], [2 Before], or [3 Before].

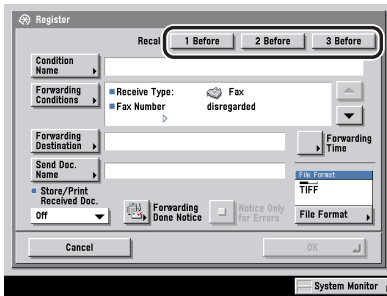

You can recall the last three forwarding settings.

### IMPORTANT

- The forwarding settings are stored in memory if you press [OK] on the Register screen or the Edit screen.
- Identical forwarding settings are stored only once in memory.

### NOTE

- The three most recent forwarding settings that were stored in memory are not erased even when the power is turned OFF.
- The forwarding settings of a received document that were not stored in memory are not displayed even when you press the recall keys.

## 4 Press [Condition Name].

## 5 Enter a name for the forwarding condition → press [OK].



### NOTE

If [Send Doc. Name] is not specified, the first 24 characters of the condition name are also stored as the document's name. However, you can change the document's name at any time.

## 6 Press [Forwarding Conditions].

## 7 Press the Receive Type drop-down list → select [Fax] or [I-Fax].

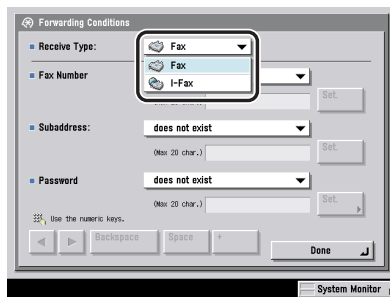

If the optional Super G3 FAX Board or Super G3 Multi-Line Fax Board is not installed, this step is not necessary. If the optional Super G3 Multi-Line Fax Board is installed, you can select the line ([Fax: Line 1], [Fax: Line 2], or [Fax: Line Shared]).

## 8 Set the forwarding conditions.

### ● If [I-Fax] is selected as the receive type:

- Press the To, From, or Subject drop-down list.

The available forwarding conditions are:

- [disregarded]: Disregards the To, From, or Subject information as forwarding conditions.
- [equals]: Forwards the document if the From or Subject information matches all of the characters entered.
- [differs from]: Forwards the document if the To, From, or Subject information differs from the characters entered.
- [begins with]: Forwards the document if the To, From, or Subject information begins with the characters entered.
- [ends with]: Forwards the document if the To, From, or Subject information ends with the characters entered.
- [contains]: Forwards the document if the To, From, or Subject information contains the characters entered.
- [does not contain]: Forwards the document if the To, From, or Subject information does not contain the characters entered.

[equals] is not an option for <To>.

- Select the forwarding condition → press [Set.].

- Enter the forwarding criterion → press [OK].

- If necessary, repeat this step for the other drop-down list(s).

If you want to change the criteria for the forwarding conditions without changing the forwarding condition for the To, From, and Subject drop-down lists, press [Set.] next to the criteria you want to change → enter the new criteria → press [OK].



### NOTE

If [disregarded] is selected as the forwarding condition, you cannot enter any criteria.

● **If [Fax] is selected as the receive type (The optional Super G3 FAX Board or Super G3 Multi-Line Fax Board is installed):**

- Select the Fax Number, Subaddress, or Password drop-down list.

The available forwarding conditions are:

- [disregarded]: Disregards the Fax Number information as a forwarding condition.
- [does not exist]: The Subaddress or Password information does not exist for the received document.
- [equals]: Forwards the document if the Fax Number, Subaddress, or Password information matches all of the characters entered.
- [differs from]: Forwards the document if the Fax Number information differs from the characters entered.
- [begins with]: Forwards the document if the Fax Number information begins with the characters entered.
- [ends with]: Forwards the document if the Fax Number information ends with the characters entered.
- [contains]: Forwards the document if the Fax Number information contains the characters entered.
- [does not contain]: Forwards the document if the Fax Number information does not contain the characters entered.

[does not exist] is not an option for <Fax Number>.

[does not exist] and [equals] are the only forwarding conditions that can be selected for <Subaddress> and <Password>.

- Select the forwarding condition → press [Set.] → enter the forwarding criterion using ① - ⑨ (numeric keys).

Details of each item are shown below.

- [◀] [▶]: Press to move the position of the cursor.
- [Backspace]: Press to delete the last number entered.
- [Space]: Press to insert a space between numbers.
- [+]: Use to insert a country code. Press [+] after the country code, and before the fax number.

- ❑ If necessary, repeat this step for the other drop-down list(s).

If you want to change the criteria for the forwarding conditions without changing the forwarding condition for the Fax Number, Subaddress, and Password drop-down lists, press [Set.] next to the criteria you want to change → enter the new criteria → press [OK].

If you select password as the forwarding conditions, press [Set.] → [Password] → enter a password using 0 - 9 (numeric keys), \*, and #. Press [Confirm] → re-enter the password for confirmation → press [OK].

You can enter up to 20 characters for the Fax Number, Subaddress, or Password forwarding criteria. The characters that can be entered are:

- Fax Number: 0 to 9, [Space], [+]
- Subaddress: 0 to 9, \*, #, [Space]
- Password: 0 to 9, \*, #, [Space]

#### NOTE

- If [disregarded] or [does not exist] is selected as the forwarding condition, you cannot enter any criteria.
- You cannot set the following combinations of conditions.

Fax Number	Subaddress	Password
[disregarded]	[does not exist]	[equals]
Other than [disregarded]	[equals]	[equals]
Other than [disregarded]	[does not exist]	[equals]
Other than [disregarded]	[equals]	[does not exist]

- If Use Asterisks to Enter Access No./Passwords in System Settings (from the Additional Functions screen) is set to 'Off', the password is not displayed as asterisks on Password screen, and you do not have to re-enter the password for confirmation. (See Chapter 6, "System Manager Settings," in the *Reference Guide*.)

## 9 Press [Done].

## 10 Press [Forwarding Destination] → select [Address Book] or [Conf. Fax Inbox].

Details of each item are shown below.

[Address Book]: Select to forward the received document to another machine (relay function).

[Conf. Fax Inbox]: Select to store the received document in a Confidential Fax Inbox.



 **NOTE**

If the selected destination is a group address which contains a User Inbox as a destination, the document is not sent and stored in that User Inbox.

● **If you select [Address Book]:**

- Select the forwarding destination → press [OK].

If Access Number Management in Restrict the Send Function in System Settings (from the Additional Functions screen) is set to 'On', and you want to select a destination that is stored with an access number, press [Access Number] → enter the access number. (See "Using the Address Book," on p. 2-23.)

Press the alphanumeric keys (e.g., [ABC]) to display the individual keys for each letter or number. You can select a letter or number to restrict the displayed range of entries. Press [All] to return to the full address list.

You can restrict the type of destinations displayed in the results list by pressing the Type drop-down list.

Press the Address Book drop-down list to display a list of subaddress books 1 to 10 or one-touch buttons. Subaddress books categorize the addresses stored in the Address Book. Select one of these subaddress books to limit the display of destinations.

You cannot select multiple destinations at the same time. To forward to multiple destinations, select a group address.

You can specify e-mail addresses, I-fax addresses, file server addresses, and group addresses as forwarding destinations.

If the optional Super G3 FAX Board or Super G3 Multi-Line Fax Board is installed, you can also specify fax numbers in addition to the above mentioned destinations as forwarding destinations.

 **NOTE**

- To cancel a selected destination, select the destination again.
- To view the detailed information of a selected destination, select the destination → press [Details].
- To be able to select a forwarding destination, it is necessary to register destinations in the Address Book beforehand. (See "Storing New Addresses," on p. 10-5.)
- [Access Number] is displayed on the screen only if Access Number Management in Restrict the Send Function in System Settings (from the Additional Functions screen) is set to 'On'. (See "Access Number Management," on p. 11-16.)
- If you select a fax number as the forwarding destination, the subaddress and password registered in the Address Book are ignored.

**● If you select [Conf. Fax Inbox]:**

- Select the desired Confidential Fax Inbox → press [OK].

You cannot select multiple Confidential Fax Inboxes.

If you want to send a link to a Confidential Fax Inbox via e-mail, press [URL Send].

If you set the machine to send a link via e-mail to the Confidential Fax Inbox in which the document is stored, you can check or perform operations on the document in the Confidential Fax Inbox, using the Remote UI (User Interface) of the machine.

A message <Confidential Fax Inbox Incoming Notice> is inserted into the body of the e-mail message stating the link to the Confidential Fax Inbox.

**IMPORTANT**

Additional documents cannot be stored in the Confidential Fax Inbox under the following conditions. (These numbers may vary depending on the remaining capacity of the hard disk.)

- When 1,500 documents have been stored in any or all of the inboxes
- When 6,000 pages have been stored in any or all of the inboxes

**NOTE**

To be able to send a link via e-mail to the Confidential Fax Inbox in which the document is stored, it is necessary to register an e-mail address in the Confidential Fax Inbox beforehand. For instructions on storing an e-mail address in the machine, see Chapter 8, "Customizing Settings," in the *Copying and Mail Box Guide*.

**11 Press [Send Doc. Name].**

If you selected a fax number or Confidential Fax Inbox as the forwarding destination, proceed to step 13.

**12 Enter the name of the document → press [OK].**

The condition name is automatically entered as the document's name by default. However, you can change this name.

**13 Press [Forwarding Time].****14 Select [Everyday], [Period Specification], or [Off].****IMPORTANT**

You cannot set the same time for both the start time and end time.

**● If you select [Everyday]:**

- Enter the start time and end time using ① - ⑨ (numeric keys) → press [OK].  
Enter all four digits of the time (including zeros), using 24-hour notation.

**NOTE**

If the end time is set earlier than the start time, the received documents will stop being forwarded at the specified end time on the following day.

For example:

Start time: 22:00, end time: 21:00

The end time refers to 21:00 on the following day.

**● If you select [Period Specification]:**

- Press [Add].
- Press the Start Time drop-down list → select a day of the week ([Sun] to [Sat]) at which to start forwarding.
- Press [□] next to the Start Time drop-down list → enter the time at which to start forwarding.  
Enter all four digits of the time (including zeros), using 24-hour notation.  
If you press [All Day], the start and end times are automatically set to '00:00'.  
The day for the end time is automatically set to the day following the day for the start time.
- Set the end time in the same way as the start time → press [OK].  
You can store up to seven different combinations of start and end times.  
To change previously stored settings, select the setting that you want to change → press [Edit].  
To erase previously stored settings, select the setting that you want to erase → press [Erase].

**NOTE**

If the end time is set earlier than the start time and both the start time and the end time are set for the same day of the week, the received documents will stop being forwarded at the specified end time on the specified day of the following week.

For example:

Start time: Monday 22:00, end time: Monday 21:00

The end time refers to Monday 21:00 of the following week.

**● If you select [Off]:**

- Press [OK].

## 15 Press the **Store/Print Received Doc.** drop-down list → select **[On]** or **[Off]**.

If you selected a Confidential Fax Inbox as the forwarding destination, proceed to step 19.

<Store/Print Received Doc.>:

[On]: The received document is stored in the Memory RX Inbox or printed.

[Off]: The received document is not stored in the Memory RX Inbox or printed.



### NOTE

- If <Store/Print Received Doc.> is set to 'On' and Memory Lock mode is set to 'On', the received document is stored in the Memory RX Inbox. (See "Storing Received I-Fax Documents in Memory," on p. 11-11, "Storing Received Fax Documents in Memory," on p. 11-10, and Chapter 6, "Receiving Documents.")
- If <Store/Print Received Doc.> is set to 'On' and Memory Lock mode is set to 'Off', the received document is printed. (See "Storing Received I-Fax Documents in Memory," on p. 11-11, "Storing Received Fax Documents in Memory," on p. 11-10, and Chapter 6, "Receiving Documents.")

## 16 Press **[Forwarding Done Notice]** → select the destination where the forwarding done notice is to be sent → press **[OK]**.

If Access Number Management in Restrict the Send Function in System Settings (from the Additional Functions screen) is set to 'On', and you want to select a destination that is stored with an access, press **[Access Number]** → enter the access number. (See "Using the Address Book," on p. 2-23.)

Press the alphanumeric keys (e.g., [ABC]) to display the individual keys for each letter or number. You can select a letter or number to restrict the displayed range of entries. Press **[All]** to return to the full address list.

Press the Address Book drop-down list to display a list of subaddress books 1 to 10 or one-touch buttons. Subaddress books categorize the addresses stored in the Address Book. Select one of these subaddress books to limit the display of destinations.

You cannot select multiple destinations at the same time.

## NOTE

- To cancel a selected destination, select the destination again.
- To view the detailed information of a selected destination, select the destination → press [Details].
- To be able to select a destination for the forwarding done notice, it is necessary to register destinations in the Address Book beforehand. (See "Storing New Addresses," on p. 10-5.)
- [Access Number] is displayed on the screen only if Access Number Management in Restrict the Send Function in System Settings (from the Additional Functions screen) is set to 'On'. (See "Access Number Management," on p. 11-16.)

## 17 Select whether to check [Notice Only for Errors].

If you want the forwarding done notice to be sent only when an error occurs, press [Notice Only for Errors].

If you want the forwarding done notice to be sent every time a received document is forwarded, do not press [Notice Only for Errors].

## 18 Press [File Format] → select the file format of the document you want to forward.

This part of the procedure is not necessary if any one of the following is true:

- A fax number is specified as the forwarding destination
- An I-fax address is specified as the forwarding destination
- A Confidential Fax Inbox is specified as the forwarding destination

If [Fax] is selected as receive type, you can select from the following file formats:

[TIFF]: Sends the file in the TIFF format.

[PDF]: Sends the file in the PDF format. You can also specify [OCR (Text Searchable)] and/or [Add Digital Signatures].

If [I-Fax] is selected as receive type, you can select from the following file formats:

[TIFF/PDF Auto Select]: Sends the file in either the TIFF (Black-and-White) or PDF (Grayscale/Color) format. [Divide into Pages] is not available if this key is selected.

[TIFF/JPEG Auto Select]: Sends images in either the TIFF (Black-and-White) or JPEG (Grayscale/Color) format. [Divide into Pages] is available if this key is selected.

[PDF]:

Sends the file in the PDF format regardless of the color mode. You can also specify [Trace & Smooth], [Compact], [OCR (Text Searchable)], and /or [Add Digital Signatures].

If you want to separate multiple images and send them as separate files, each of which consists of only one page, press [Divide into Pages], and the key lights. If you want to send multiple images as a single file without dividing them, do not press [Divide into Pages], and the key remains unlit.

 **NOTE**

- To view a JPEG file, software that supports the JPEG format (such as Microsoft Internet Explorer for Windows) is required.
- To view a TIFF file, software that supports the TIFF format (such as Imaging for Windows) is required.
- To view a PDF file, software that supports the PDF format (such as Adobe Reader/Adobe Acrobat) is required.
- For more information on the different file formats, see "File formats," in the Glossary on p. 14-28.

## 19 Press [OK].

 **IMPORTANT**

You cannot set multiple forwarding conditions that contain the same subaddress setting.

## 20 If necessary, press the E-mail Priority drop-down list → select a priority for your forwarded e-mail messages.

This setting is necessary only if the forwarding destination is an e-mail address.

# When Forwarding Destinations Do Not Match the Forwarding Conditions

You can store the forwarding destinations of a received document if the forwarding settings of the received document are not registered, or if the received document does not match all of the forwarding conditions that you have specified.

## IMPORTANT

If the optional Super G3 FAX Board or Super G3 Multi-Line Fax Board is installed and the subaddress and password specified from the sending machine do not match the registered forwarding conditions, the documents are not forwarded to forwarding destinations registered in Forward w/o Conditions in Forwarding Settings in System Settings (from the Additional Functions screen), and the faxed documents are not received.

## NOTE

Forwarding destinations can be stored one at a time, according to the receive type of the received document.

**1** Press  (Additional Functions) → [System Settings] → [Forwarding Settings] → [Forward w/o Conditions].

**2** Press the Receive Type drop-down list → select [Fax] or [I-Fax].

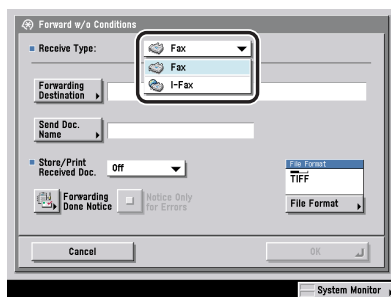

If the optional Super G3 FAX Board or Super G3 Multi-Line Fax Board is not installed, this step is not necessary. If the optional Super G3 Multi-Line Fax Board is installed, you can select the line ([Fax: Line 1], [Fax: Line 2], or [Fax: Line Shared]).

### 3 Press [Forwarding Destination]→ select [Address Book] or [Conf. Fax Inbox].

Details of each item are shown below.

[Address Book]: Select to forward the received document to another machine (relay function).

[Conf. Fax Inbox]: Select to store the received document in a Confidential Fax Inbox.



#### NOTE

If the selected destination is a group address which contains a User Inbox as a destination, the document is not sent and stored in that User Inbox.

#### ● If you select [Address Book]:

- Select the forwarding destination → press [OK].

If Access Number Management in Restrict the Send Function in System Settings (from the Additional Functions screen) is set to 'On', and you want to select a destination that is stored with an access number, press [Access Number] → enter the access number. (See "Using the Address Book," on p. 2-23.)

Press the alphanumeric keys (e.g., [ABC]) to display the individual keys for each letter or number. You can select a letter or number to restrict the displayed range of entries. Press [All] to return to the full address list.

You can restrict the type of destinations displayed in the results list by pressing the Type drop-down list.

Press the Address Book drop-down list to display a list of subaddress books 1 to 10 or one-touch buttons. Subaddress books categorize the addresses stored in the Address Book. Select one of these subaddress books to limit the display of destinations.

You cannot select multiple destinations at the same time.

You can specify e-mail addresses, I-fax addresses, file server addresses, and group addresses as forwarding destinations.

If the optional Super G3 FAX Board or Super G3 Multi-Line Fax Board is installed, you can also specify fax numbers in addition to the above mentioned destinations as forwarding destinations.



 **NOTE**

- To cancel a selected destination, select the destination again.
- To view the detailed information of a selected destination, select the destination → press [Details].
- To be able to select a forwarding destination, it is necessary to register destinations in the Address Book beforehand. (See "Storing New Addresses," on p. 10-5.)
- [Access Number] is displayed on the screen only if Access Number Management in Restrict the Send Function in System Settings (from the Additional Functions screen) is set to 'On'. (See "Access Number Management," on p. 11-16.)
- If you select a fax number as the forwarding destination, the subaddress and password registered in the Address Book are ignored.

**● If you select [Conf. Fax Inbox]:**

- Select the desired Confidential Fax Inbox → press [OK].

You cannot select multiple Confidential Fax Inboxes.

If you want to send a link to a Confidential Fax Inbox via e-mail, press [URL Send].

If you set the machine to send a link via e-mail to the Confidential Fax Inbox in which the document is stored, you can check or perform operations on the document in the Confidential Fax Inbox, using the Remote UI (User Interface) of the machine.

A message <Confidential Fax Inbox Incoming Notice> is inserted into the body of the e-mail message stating the link to the Confidential Fax Inbox.

 **IMPORTANT**

Additional documents cannot be stored in the Confidential Fax Inbox under the following conditions. (These numbers may vary depending on the remaining capacity of the hard disk.)

- When 1,500 documents have been stored in any or all of the inboxes
- When 6,000 pages have been stored in any or all of the inboxes

 **NOTE**

To be able to send a link via e-mail to the Confidential Fax Inbox in which the document is stored, it is necessary to register an e-mail address in the Confidential Fax Inbox beforehand. For instructions on storing an e-mail address in the machine, see Chapter 8, "Customizing Settings," in the *Copying and Mail Box Guide*.

**4 Press [Send Doc. Name].**

If you selected a fax number or Confidential Fax Inbox as the forwarding destination, proceed to step 6.

**5 Enter the name of the document → press [OK].**

## 6 Press the **Store/Print Received Doc.** drop-down list → select **[On]** or **[Off]**.

If you select a Confidential Fax Inbox as the forwarding destination, proceed to step 11.

<Store/Print Received Doc>:

[On]: The received document is stored in the Memory RX Inbox or printed.

[Off]: The received document is not stored in the Memory RX Inbox or printed.



### NOTE

- If <Store/Print Received Doc.> is set to 'On' and Memory Lock mode is set to 'On', the received document is stored in the Memory RX Inbox. (See "Storing Received I-Fax Documents in Memory," on p. 11-11, "Storing Received Fax Documents in Memory," on p. 11-10, and Chapter 6, "Receiving Documents.")
- If <Store/Print Received Doc.> is set to 'On' and Memory Lock mode is set to 'Off', the received document is printed. (See "Storing Received I-Fax Documents in Memory," on p. 11-11, "Storing Received Fax Documents in Memory," on p. 11-10, and Chapter 6, "Receiving Documents.")

## 7 Press **[Forwarding Done Notice]**.

## 8 Select the destination where the forwarding done notice is to be sent → press **[OK]**.

If Access Number Management in Restrict the Send Function in System Settings (from the Additional Functions screen) is set to 'On', and you want to select a destination that is stored with an access number, press [Access Number] → enter the access number. (See "Using the Address Book," on p. 2-23.)

Press the alphanumeric keys (e.g., [ABC]) to display the individual keys for each letter or number. You can select a letter or number to restrict the displayed range of entries. Press [All] to return to the full address list.

Press the Address Book drop-down list to display a list of subaddress books 1 to 10 or one-touch buttons. Subaddress books categorize the addresses stored in the Address Book. Select one of these subaddress books to limit the display of destinations.

You cannot select multiple destinations at the same time.

## NOTE

- To cancel a selected destination, select the destination again.
- To view the detailed information of a selected destination, select the destination → press [Details].
- To be able to select a destination for the forwarding done notice, it is necessary to register destinations in the Address Book beforehand. (See "Storing New Addresses," on p. 10-5.)
- [Access Number] is displayed on the screen only if Access Number Management in Restrict the Send Function in System Settings (from the Additional Functions screen) is set to 'On'. (See "Access Number Management," on p. 11-16.)

## 9 Select whether to check [Notice Only for Errors].

If you want the forwarding done notice to be sent only when an error occurs, press [Notice Only for Errors].

If you want the forwarding done notice to be sent every time a received document is forwarded, do not press [Notice Only for Errors].

## 10 Press [File Format] → select the file format of the document you want to forward.

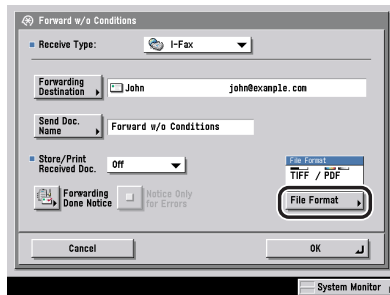

This part of the procedure is not necessary if any one of the following is true:

- An I-fax address is specified as the forwarding destination
- A fax number is specified as the forwarding destination
- A Confidential Fax Inbox is specified as the forwarding destination

If [Fax] is selected as the receive type, you can select from the following file formats:

[TIFF]: Sends the file in the TIFF format.

[PDF]: Sends the file in the PDF format. You can also specify [OCR (Text Searchable)] and/or [Add Digital Signatures].

If [I-Fax] is selected as the receive type, you can select from the following file formats:

- [TIFF/PDF Auto Select]: Sends the file in either the TIFF (Black-and-White) or PDF (Grayscale/Color) format. [Divide into Pages] is not available if this key is selected.
- [TIFF/JPEG Auto Select]: Sends images in either the TIFF (Black-and-White) or JPEG (Grayscale/Color) format. [Divide into Pages] is available if this key is selected.
- [PDF]: Sends the file in the PDF format regardless of the color mode. You can also specify [Trace & Smooth], [Compact], [OCR (Text Searchable)], and /or [Add Digital Signatures].  
If you want to separate multiple images and send them as separate files, each of which consists of only one page, press [Divide into Pages], and the key lights. If you want to send multiple images as a single file without dividing them, do not press [Divide into Pages], and the key remains unlit.

 **NOTE**

- To view a JPEG file, software that supports the JPEG format (such as Microsoft Internet Explorer for Windows) is required.
- To view a TIFF file, software that supports the TIFF format (such as Imaging for Windows) is required.
- To view a PDF file, software that supports the PDF format (such as Adobe Reader/Adobe Acrobat) is required.
- For more information on the different file formats, see "File formats," in the Glossary on p. 14-28.

## 11 Press [OK] → [OK].

# Checking/Changing Forwarding Settings

You can check or change forwarding settings that have been stored.

- 1** Press  (Additional Functions) → [System Settings] → [Forwarding Settings].
- 2** Select the forwarding setting whose details you want to check → press [Edit].

### 3 Check or change the forwarding settings → press [OK].



#### NOTE

For instructions on changing forwarding settings, see "Storing Forwarding Settings," on p. 11-23.

## Forwarding Received Documents

You can set whether received documents are forwarded.

**1** Press  (Additional Functions) → [System Settings] → [Forwarding Settings].

**2** Select the desired forwarding setting → press [Validate/Invalidate].

When you select the desired forwarding setting and press [Validate/Invalidate], the "On" or "Off" status displayed on the left side of the Condition Name is switched. (i.e., "On" becomes "Off," and "Off" becomes "On.")

<On>: The received document is forwarded to the specified destination if it matches the forwarding conditions.

<Off>: The received document is not forwarded to the specified destination even if it matches the forwarding conditions.

To cancel forwarding, press [Validate/Invalidate] again.

## Erasing Forwarding Settings

You can erase forwarding settings that have been stored.

**1** Press  (Additional Functions) → [System Settings] → [Forwarding Settings].

**2** Select the forwarding setting that you want to erase → press [Erase].

**3** Press [Yes].

# Printing Forwarding Settings

You can print a list of the stored forwarding settings.

---

**1** Press  (Additional Functions) → [System Settings] → [Forwarding Settings].

**2** Press [Print List].



**NOTE**

The forwarding settings can be printed only if 11" x 17", LGL, LTR, or LTRR paper (plain, recycled, or color paper) is loaded in the paper sources whose settings in Other in Drawer Eligibility For APS/ADS in Common Settings (from the Additional Functions screen) are set to 'On'. (See Chapter 4, "Customizing Settings," in the *Reference Guide*.)

**3** Press [Yes].

# LDAP Server Settings

If the information for an LDAP (Lightweight Directory Access Protocol) server is registered in the machine, you can search for e-mail addresses and fax numbers via the LDAP server. E-mail addresses and fax numbers obtained via the server can be specified as destinations or stored in the Address Book.

## NOTE

- The following types of LDAP servers can be used with this machine:
  - Windows 2000 Server with Active Directory
  - Novell NetWare 5.1 (NDS) or later
  - Lotus Notes Domino R5 or laterFor more information, contact your local authorized Canon dealer.
- You can register up to five LDAP servers.

## Registering an LDAP Server

You have to specify the relevant information for the LDAP server, such as the server name and address.

- 1** Press  (Additional Functions) → [System Settings] → [Register LDAP Server] → [Register].
- 2** Specify each setting → press [Next].

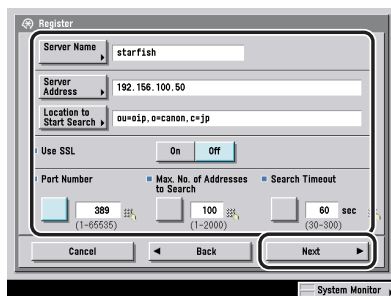

[Server Name]:

Enter a server name → press [OK].

[Server Address]:

Press [Server Address] → enter the server's address → press [OK].

[Location to Start Search]:

Press [Location to Start Search] → enter the location to start searching → press [OK].

If the server's LDAP version is 3, then you do not have to specify [Location to Start Search]. (If the LDAP version is 3, the machine automatically retrieves settings from the server, and sets the location to start searching.) If the server's LDAP version is 2, you have to specify [Location to Start Search].

Enter the location to start searching according to the type of LDAP server you are using, or as described below.

- If you are using Windows 2000 Server with Active Directory:  
Add "DC=" to each dot separated series of characters in the Active Directory domain name, and separate each series of characters by a comma.  
Example: If <team1.salesdept.canon.co.jp> is the domain name in Active Directory:  
DC=team1, DC=salesdept, DC=canon, DC=co, DC=jp
- If you are using Novell NetWare 5.1 (NDS) or later:  
Add the corresponding object class "o=", "ou=", or "c=" to each dot-separated series of characters that configure the distinguished name, and separate each series of characters by a comma.  
Example: If <TEAM1.SALESDEPT.CANON> is the distinguished name in NDS:  
ou=team1, ou=salesdept, o=canon
- If you are using Lotus Notes Domino R5 or later:  
Enter the dn (Distinguished Name) of the node on the directory tree, such as "ou=team1", "ou=salesdept", "o=canon", or "c=jp".

<Use SSL>:

[On]: SSL is used. Using SSL encodes the content of the communication, and ensures greater security.

[Off]: SSL is not used.

<Port Number>:

Press [Port Number] → enter a port number using

⓪ - ⑨ (numeric keys).

<Max. No. of Addresses to Search>:

Press [Max. No. of Addresses to Search] → enter the maximum number of addresses to search using ⓪ - ⑨ (numeric keys).

<Search Timeout>:

Press [Search Timeout] → enter the timeout time, in seconds, using

⓪ - ⑨ (numeric keys) → press [Next].



 **IMPORTANT**

If <Login Information> is set to 'Use (security auth.)' for the LDAP server and Reverse DNS Lookup (a function that looks up the host name from the IP address) is not supported, enter a host name instead of an IP address.

**3 Select [Do not use], [Use], or [Use (security auth.)] for <Login Information>.**

 **IMPORTANT**

- [Use (security auth.)] next to <Login Information> can be selected only if the LDAP server is running on Windows 2000 Server with Active Directory.
- If you entered an IP address in step 2, and Reverse DNS Lookup (a function that looks up the host name from the IP address) is not supported, select either [Do not use] or [Use].
- If <Login Information> is set to 'Use (security auth.)', and if Date & Time Settings in System Settings (from the Additional Functions screen) is different from the time settings on the LDAP server, the machine may not be able to connect to the LDAP server.

● **If [Do not use] is selected:**

- Select the Server LDAP version and character code → press [OK].

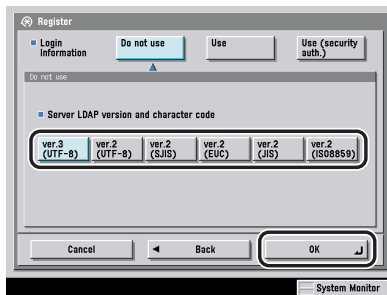

Select the LDAP version and character code according to the LDAP server's environment.

● If [Use] is selected:

- Specify each setting → press [OK].

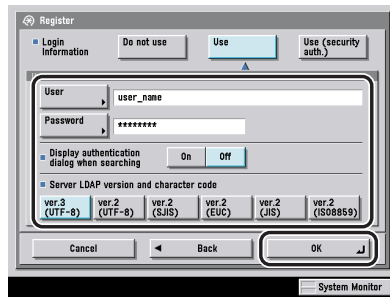

[User]:

Press [User] → enter a user name → press [OK].

Enter the user name according to the type of LDAP server you are using.

- If you are using Windows 2000 Server with Active Directory:  
Press [User] → enter "Windows domain name/Windows user name".  
Example: If <team1> is the Windows domain name, and <user1> is the Windows user name:  
team1/user1
- If you are using Novell NetWare 5.1 (NDS) or later:  
Press [User] → add the corresponding object class "o=", "ou=", or "c=" to each dot-separated series of characters that configure the distinguished name, and separate each series of characters by a comma.  
Example: If <user1.TEAM1.SALESDEPT.CANON> is the distinguished name in NDS:  
cn=user1, ou=team1, ou=salesdept, o=canon
- If you are using Lotus Notes Domino R5 or later:  
Press [User] → enter the dn (Distinguished Name) of the user, such as "cn=admin", "ou=team1", or "ou=salesdept".

[Password]:

Press [Password] → enter a password → press [OK].

Press [Confirm] → re-enter the password for confirmation → press [OK] → [OK].

After pressing [OK], the password that you entered appears as asterisks (\*\*\*\*\*) on the Register screen.

<Display authentication dialog when searching>:

[On]: When searching for information on the server, a login information dialog box is displayed even if a password is not required.

[Off]: When searching for information on the server, a login information dialog box is not displayed.

<Server LDAP version and character code>:

Select the LDAP version and character code according to the LDAP server's environment.

● If [Use (security auth.)] is selected:

- Specify each setting → press [OK].

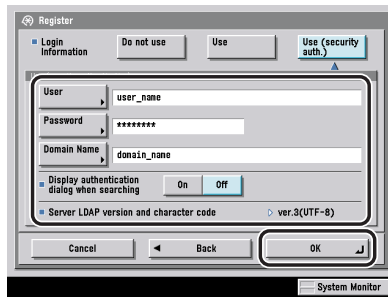

[User]:

Press [User] → enter a user name → press [OK].

Example: If <user1> is the Windows user name:

user1

[Password]:

Press [Password] → enter a password → press [OK].

Re-enter the password for confirmation → press [OK].

After pressing [OK], the password that you entered appears as asterisks (\*\*\*\*\* ) on the Register screen.

[Domain Name]:

Press [Domain Name] → enter a domain name → press [OK].

Enter the directory tree name of the Active Directory, such as <team1.salesdept.canon.co.jp>.

<Display authentication dialog when searching>:

[On]: When searching for information on the server, a login information dialog box is displayed even if a password is not required.

[Off]: When searching for information on the server, a login information dialog box is not displayed.

 **NOTE**

If Use Asterisks to Enter Access No./Passwords in System Settings (from the Additional Functions screen) is set to 'Off', the password that you enter is not displayed as asterisks on the Password screen. (See Chapter 6, "System Manager Settings," in the *Reference Guide*.)

## Changing an LDAP Server Setting

You can change the settings for a stored LDAP (Lightweight Directory Access Protocol) server.

- 1** Press **Ⓞ** (Additional Functions) → [System Settings] → [Register LDAP Server].
- 2** Select the LDAP server whose settings you want to change → press [Edit].
- 3** Change the necessary settings → press [Next].
- 4** Select [Do not use], [Use], or [Use (security auth.)] for <Login Information> → change the settings for the selected mode → press [OK].

## Deleting an LDAP Server

You can delete a stored LDAP server.

- 1** Press **Ⓞ** (Additional Functions) → [System Settings] → [Register LDAP Server].
- 2** Select the LDAP server that you want to erase → press [Erase].
- 3** Press [Yes].

# Registering/Editing LDAP Search Attributes

You can register or edit the LDAP search attributes.

- 1** Press **ⓧ** (Additional Functions) → [System Settings] → [Register LDAP Server] → [Register/Edit LDAP Search].
- 2** Register/edit the LDAP search attributes.

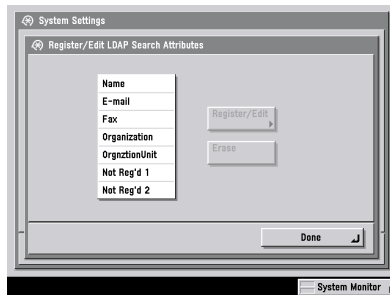

## ● To register a search attribute:

- Press [Not Reg'd 1] or [Not Reg'd 2] → [Register/Edit].
- Press [Display Name] → enter the name to display → press [OK].
- Press [Attribute Name] → enter the attribute name → press [OK].
- Press [OK].

## ● To edit a search attribute:

- Select the search attribute that you want to edit → press [Register/Edit].



## NOTE

You can only edit the two search attributes displayed as 'Not Registered' by default. You cannot edit the name, e-mail, fax, organization, and organization unit attributes.

- Press [Display Name] → enter the name to display → press [OK].
- Press [Attribute Name] → enter the attribute name → press [OK].
- Press [OK].

## ● To erase a search category:

- Select the search category that you want to erase → press [Erase].



#### NOTE

You can only edit the two search attributes displayed as 'Not Registered' by default. You cannot edit the Name, E-mail, Fax, Organization, and OrganizationUnit attributes.

- Press [OK].

## Printing LDAP Server Settings

You can print the LDAP server settings.



#### NOTE

For more information on the Registered LDAP Server List, see "Registered LDAP Server List," on p. 14-16.

---

**1** Press  (Additional Functions) → [System Settings] → [Register LDAP Server].

**2** Press [Print List].



#### NOTE

The Registered LDAP Server List can be printed only if 11" x 17", LGL, LTR, or LTRR paper (plain, recycled, or color paper) is loaded in the paper sources whose settings in Other in Drawer Eligibility For APS/ADS in Common Settings (from the Additional Functions screen) are set to 'On'. (See Chapter 4, "Customizing Settings," in the *Reference Guide*.)

**3** Press [Yes].

# Printing Communication Reports

# 12

CHAPTER

This chapter explains the method of setting the contents of a communications report and printing lists.

---

Report Settings Table . . . . .	12-2
Specifying Report Settings . . . . .	12-4
Send TX Report . . . . .	12-4
Activity Report . . . . .	12-5
Fax TX Report . . . . .	12-7
Fax Activity Report . . . . .	12-8
Fax RX Report . . . . .	12-9
Confidential Fax Inbox RX Report . . . . .	12-10
Printing Lists . . . . .	12-11
Address Book List . . . . .	12-11
User's Data List . . . . .	12-12

# Report Settings Table

The following items can be stored or set in Report Settings from the Additional Functions screen.

## ■ Settings

Item	Settings	Delivered	Applicable Page
<b>Send</b>			
TX Report	For Error Only* <sup>1</sup> , On, Off Report with TX Image: On* <sup>1</sup> , Off Report with Color TX Image: On, Off* <sup>1</sup>	Yes	p. 12-4
Activity Report		Yes	p. 12-5
Auto Print	On* <sup>1</sup> , Off		
Daily Activity Report Time	On, Off* <sup>1</sup> Time Settings: 00:00 to 23:59		
Send/Receive Separate	(Not Selected* <sup>1</sup> )		
<b>Fax*<sup>2</sup></b>			
Fax TX Report	For Error Only* <sup>1</sup> , On, Off Report with TX Image: On* <sup>1</sup> , Off	Yes	p. 12-7
Fax Activity Report		Yes	p. 12-8
Auto Print	On* <sup>1</sup> , Off		
Daily Activity Report Time	On, Off* <sup>1</sup> Time Settings: 00:00 to 23:59		
Send/Receive Separate	(Not Selected* <sup>1</sup> )		
Fax RX Report	For Error Only, On, Off* <sup>1</sup>	Yes	p. 12-9
Confidential Fax Inbox RX Report	On* <sup>1</sup> , Off	Yes	p. 12-10

\*<sup>1</sup> Indicates the default setting.

\*<sup>2</sup> Indicates item that appears only if the optional Super G3 FAX Board or Super G3 Multi-Line Fax Board is installed.



## ■ Print List

Item	Settings	Delivered	Applicable Page
<b>Send</b>			
Address Book List	Address Book 1 to 10, One-touch Buttons Print List: Print	No	p. 12-11
User's Data List	Print List	No	p. 12-12
<b>Fax<sup>*2</sup></b>			
User's Data List	Print List	No	p. 12-12

\*2 Indicates item that appears only if the optional Super G3 FAX Board or Super G3 Multi-Line Fax Board is installed.

### NOTE

- For instructions on setting the modes not described in this manual, refer to the other manuals listed in "Manuals for the Machine," on p. ii.
- The Report Settings screen consists of a list of individual settings.
- Information that is delivered when the Device Information Delivery Settings mode is set, is marked with "Yes" in the "Delivered" column. For instructions on setting the Device Information Delivery Settings mode, see Chapter 6, "System Manger Settings," in the *Reference Guide*.

# Specifying Report Settings

You can specify how various reports are printed.

## NOTE

The reports can be printed only if 11" x 17", LGL, LTR, or LTRR paper (plain, recycled, or color paper) is loaded in the paper sources whose settings in Other in Drawer Eligibility For APS/ADS in Common Settings (from the Additional Functions screen) are set to 'On'. (See Chapter 4, "Customizing Settings," in the *Reference Guide*.)

## Send TX Report

The Send TX Report enables you to check whether documents were sent correctly to their intended destinations. A Send TX Report can be printed automatically after the documents are sent. You can also set the machine to print a Send TX Report only when a transmission error occurs, and adjust the Send TX Report setting to print the first part of the document as part of the report to remind you of the document's contents.

## NOTE

- The results of e-mail, I-fax, file server, and User Inbox transmissions can be printed.
- If the optional Super G3 FAX Board or Super G3 Multi-Line Fax Board is installed, the results of fax transmissions are included in the Send TX Report. In addition, a Fax TX Report is printed with the Send TX Report. (See "Fax TX Report/Fax Error TX Report," on p. 14-5.)
- For an example of a Send TX Report, see "Send TX Report," on p. 14-3.

---

**1** Press  (Additional Functions) → [Report Settings] → [Send] under <Settings> → [TX Report].

## 2 Select [For Error Only], [On], or [Off].

### ● If you select [For Error Only] or [On]:

- Select [On] or [Off] for <Report with TX Image>.

<Report with TX Image>:

[On]: Part of the sent document is printed on the Send TX Report.

[Off]: The contents of the sent document are not printed on the Send TX Report.

- Select [On] or [Off] for <Report with Color TX Image> → press [OK].

<Report with Color TX Image>:

[On]: Color documents are printed on the Send TX Report.

[Off]: Color documents are not printed on the Send TX Report.

[Report with Color TX Image] can only be set if [Report with TX Image] is set to 'On'.



### NOTE

Even if <Report with TX Image> is set to 'On', the original will not be printed in the following cases:

- If the first page of the original is color, and <Report with Color TX Image> is set to 'Off'
- If the document was sent using the Encrypted PDF mode

### ● If you select [Off]:

- Press [OK].

The Send TX Report is not printed.

## Activity Report

The Activity Report is a printed log that shows the results of send and receive jobs. The Activity Report can be printed at a specified time or it can be printed automatically when the number of send and receive transmissions reaches 100. The send and receive logs can also be printed separately.

An Activity Report can be printed manually from the System Monitor screen. (See "Printing the Send Job Status/Log," on p. 8-8, and "Printing the Receive Job Log," on p. 8-13.)

 NOTE

- If Job Log Display in System Settings (from the Additional Functions screen) is set to 'Off', [Activity Report] is not displayed.
- If Job Log Display in System Settings (from the Additional Functions screen) is changed from 'Off' to 'On', the following settings are switched to 'Off' automatically:
  - Auto Print
  - Daily Activity Report Time
- E-mail, I-fax, file server, and User Inbox transmission logs are printed.
- If the optional Super G3 FAX Board or Super G3 Multi-Line Fax Board is installed, a list of fax transmission logs in addition to the above mentioned transmission logs are printed.
- For an example of an Activity Report, see "Activity Report," on p. 14-11.

**1** Press  (Additional Functions) → [Report Settings] → [Send] under <Settings> → [Activity Report].

**2** Specify each setting → press [OK].

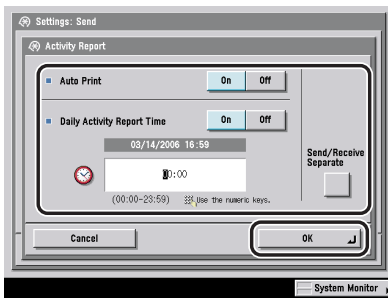

<Auto Print>:

[On]: The Activity Report is automatically printed when the number of send and receive transmissions reaches 100.

[Off]: The Activity Report is not automatically printed when the number of send and receive transmissions reaches 100.

<Daily Activity Report Time>:

[On]: The Daily Activity Report is printed at the specified time.

[Off]: The Daily Activity Report Time setting is not specified.

Enter all four digits of the time (including zeros), using 24-hour notation.

Examples: 7:05 a.m. → 0705

11:18 p.m. → 2318

If you make a mistake when entering the time, press  (Clear) to clear your entry → enter another four digit number.

If the number of send and receive transmissions exceeds 100 before the specified time, an Activity Report of the most recent 100 transmissions is printed.

<Send /Receive Separate>:

To print the send and receive logs separately, press [Send/Receive Separate] to select it.

If it is not necessary to print the send and receive logs separately, do not press [Send/Receive Separate].

## Fax TX Report

The Fax TX Report enables you to check whether documents were sent correctly to their intended destinations. A Fax TX Report can be printed automatically after the documents are sent. You can also set the machine to print a Fax TX Report only when a transmission error occurs, and adjust the Fax TX Report setting to print the first part of the document as part of the report to remind you of the document's contents.

### NOTE

- This mode is available only if the optional Super G3 FAX Board or Super G3 Multi-Line Fax Board is installed.
- For an example of a Fax TX Report, see "Fax TX Report/Fax Error TX Report," on p. 14-5.
- If TX Report in Send under <Settings> in Report Settings (from the Additional Functions screen) is set to 'For Error Only' or 'On', a Send TX Report is printed with the Fax TX Report.

---

**1** Press  (Additional Functions) → [Report Settings] → [Fax] under <Settings> → [Fax TX Report].

## 2 Select [For Error Only], [On], or [Off].

### ● If you select [For Error Only] or [On]:

- Select [On] or [Off] for <Report with TX Image> → press [OK].

<Report with TX Image>:

[On]: Part of the sent document is printed on the Fax TX Report.

[Off]: The contents of the sent document are not printed on the Fax TX Report.

### ● If you select [Off]:

- Press [OK].

The Fax TX Report is not printed.

## Fax Activity Report

The Fax Activity Report is a printed log that shows the results of send and receive jobs. The Fax Activity Report can be printed at a specified time or it can be printed automatically when the number of send and receive transmissions reaches 40. The send and receive logs can also be printed separately.

A copy of the Fax Activity Report can be printed at any time from the System Monitor screen. (See "Printing the Fax Activity Report," on p. 8-11.)

### NOTE

- This mode is available only if the optional Super G3 FAX Board or Super G3 Multi-Line Fax Board is installed.
- If Job Log Display in System Settings (from the Additional Functions screen) is set to 'Off', [Fax Activity Report] is not displayed.
- If Job Log Display in System Settings (from the Additional Functions screen) is changed from 'Off' to 'On', the following settings are switched to 'Off' automatically:
  - Auto Print
  - Daily Activity Report Time
- For an example of a Fax Activity Report, see "Fax Activity Report," on p. 14-13.

## 1 Press (Additional Functions) → [Report Settings] → [Fax] under <Settings> → [Fax Activity Report].

## 2 Specify each setting → press [OK].

<Auto Print>:

[On]: The Activity Report is automatically printed when the number of send and receive transmissions reaches 40.

[Off]: The Activity Report is not automatically printed when the number of send and receive transmissions reaches 40.

<Daily Activity Report Time>:

[On]: The Fax Activity Report is printed at the specified time.

[Off]: The Daily Activity Report Time setting is not specified.

Enter all four digits of the time (including zeros), using 24-hour notation.

Examples: 7:05 a.m. → 0705

11:18 p.m. → 2318

If you make a mistake when entering the time, press to clear your entry → enter another four digit number.

If the number of send and receive transmissions exceeds 40 before the specified time, a Fax Activity Report of the most recent 40 transmissions is printed.

<Send/Receive Separate>:

To print the send and receive logs separately, press [Send/Receive Separate] to select it.

If it is not necessary to print the send and receive logs separately, do not press [Send/Receive Separate].

## Fax RX Report

The Fax RX Report enables you to check whether documents were sent correctly from the sender's machine and received successfully by this machine. A Fax RX Report can be printed automatically after documents are received, and you can also set the machine to print a Fax RX Report only when a reception error occurs.

### NOTE

- This mode is available only if the optional Super G3 FAX Board or Super G3 Multi-Line Fax Board is installed.
- For an example of a Fax RX Report, see "Fax RX Report," on p. 14-8.

---

**1** Press  (Additional Functions) → [Report Settings] → [Fax] under <Settings> → [Fax RX Report].

**2** Select [For Error Only], [On], or [Off] → press [OK].

Details of each item are shown below.

[For Error Only]: Prints a Fax RX Report only when a reception error occurs.

[On]: Prints a Fax RX Report each time a document is received.

[Off]: Does not print a Fax RX Report.

## Confidential Fax Inbox RX Report

The Confidential Fax Inbox RX Report enables you to check the reception of documents in Confidential Fax Inboxes.

 **NOTE**

- This mode is available only if the optional Super G3 FAX Board or Super G3 Multi-Line Fax Board is installed.
- For an example of a Confidential Fax Inbox RX Report, see "Confidential Fax Inbox Reception Report," on p. 14-9.

---

**1** Press  (Additional Functions) → [Report Settings] → [Fax] under <Settings> → [Confidential Fax Inbox RX Report].

**2** Select [On] or [Off] → press [OK].



# Printing Lists

You can print the contents of the Address Book or a list of Send settings that have been specified from the Additional Functions screen.

## NOTE

The lists can be printed only if 11" x 17", LGL, LTR, or LTRR paper (plain, recycled, or color paper) is loaded in the paper sources whose settings in Other in Drawer Eligibility For APS/ADS in Common Settings (from the Additional Functions screen) are set to 'On'. (See Chapter 4, "Customizing Settings," in the *Reference Guide*.)

## Address Book List

You can print the contents of the Address Book (subaddress books 1 to 10 or one-touch buttons). This is useful for checking the details of the destinations.

## IMPORTANT

Even if Access Number Management in Restrict the Send Function in System Settings (from the Additional Functions screen) is set to 'On', all of the destinations in the selected subaddress book (including those stored with Access numbers) are printed in the Address Book list.

## NOTE

For an example of an Address Book List, see "Address Book List," on p. 14-17.

- 1** Press  (Additional Functions) → [Report Settings] → [Send] under <Print List> → [Address Book List].
- 2** Select one of the subaddress books 1 to 10 or [One-touch Buttons] → press [Print List].
- 3** Press [Yes].

## User's Data List

You can print a list of Send or Fax settings that have been specified from the Additional Functions screen. This is useful for checking the details of the settings.

### NOTE

- The following two types of User's Data Lists are available:
  - Send: Prints all information related to the Send function stored from the Additional Functions screen.
  - Fax: Prints all information related to the Fax function stored from the Additional Functions screen.
- For an example of the User's Data List, see "User's Data List," on p. 14-19.

### *Printing the User's Data List for send*

- 1** Press  (Additional Functions) → [Report Settings] → [Send] under <Print List> → [User's Data List].
- 2** Press [Yes].

### *Printing the User's Data List for fax*

- 1** Press  (Additional Functions) → [Report Settings] → [Fax] under <Print List> → [User's Data List].
- 2** Press [Yes].

# 13

## CHAPTER

# Troubleshooting

This chapter describes the procedures for taking corrective action in the event that trouble occurs. The end of the chapter shows you how to respond to error messages and contains a list of frequently asked questions and answers.

---

When Problems Occur . . . . .	13-2
Sending Documents . . . . .	13-2
Receiving Documents . . . . .	13-5
Other Situations . . . . .	13-7
Error Messages . . . . .	13-9
Self-Diagnostic Display . . . . .	13-9
List of Error Codes without Messages . . . . .	13-14
Questions & Answers . . . . .	13-37

# When Problems Occur

## Sending Documents

---

### Canceling transmissions.

---

**Q** How do you cancel a transmission while a document is being scanned?

**A** Press  (Stop) on the control panel, or press [Cancel] on the touch panel display.

**Q** How do you cancel a transmission after the document has been scanned?

**A** If you are sending the document by any other sending method besides fax, press [System Monitor] → [Send] → [Status] → select the document that you want to cancel → press [Cancel] → [Yes]. However, documents that are being sent may not be canceled even if you press [Cancel]. (See "Using the System Monitor Screen," on p. 1-36.)

**A** If you are sending the document by fax, press [System Monitor] → [Fax] → [Send Job Status] → select the document that you want to cancel → press [Cancel] → [Yes]. However, documents that are being sent may not be canceled even if you press [Cancel]. (See "Using the System Monitor Screen," on p. 1-36.)

**Q** Are you sending a fax document using the Direct Sending mode?

**A** Press  (Stop) on the control panel, or press [Cancel] on the touch panel display.

---

Document cannot be sent.

---

**Q** Is the destination setting correct?

**A** Check the destination setting of the recipient.

**Q** Is the destination stored in the Address Book correct?

**A** Check the destination in the Address Book. (See "Editing Address Details," on p. 10-30.)

**Q** Has trouble occurred in the remote machine?

**A** Check to ensure that the remote machine can receive documents. If it cannot, check to see whether the machine is turned OFF, is out of recording paper, or has insufficient available memory.

**Q** If you are sending an e-mail message or I-fax, are the SMTP Server and DNS Server settings correct?

**A** Check the SMTP Server and DNS Server settings.

**Q** If you are sending to a file server, are the User and Password settings correct?

**A** Check the User and Password settings, and send the document again.

**Q** If you are sending to a file server, are the shared folder settings correct?

**A** Check the shared folder settings. (See Chapter 5, "Using a NetBIOS Network," in the *Network Guide*.)

---

Document cannot be sent (if the optional Super G3 FAX Board or Super G3 Multi-Line Fax Board is installed).

---

**Q** Is the telephone line type set correctly?

**A** Check the type of telephone line that has been set. (See "Selecting the Type of Telephone Line," on p. 1-14.)

**Q** If you are sending with a subaddress setting, did you enter the correct subaddress and password for the destination?

**A** Check the subaddress and password settings.

**Q** Is the line connected to a private branch exchange switchboard or terminal adapter?

**A** Set Check Dial Tone Before Sending in TX Settings under <Fax Settings> in Communications Settings (from the Additional Functions screen) to 'Off'. (See Chapter 9, "Setting/Storing the Communications Settings.")

---

Memory is full.

---

**Q** Are unwanted documents stored in memory?

**A** Check the TX Document and RX Document memory, and erase unnecessary documents and documents with errors from memory. (See "Erasing Received Documents," on p. 6-8, and Chapter 2, "Introduction to the Mail Box Functions," in the *Copying and Mail Box Guide*.)

---

The document does not print clearly on the remote machine.

---

**Q** Is the platen glass clean?

**A** Use your machine to make a copy of the document, and check it for streaks. If streaks appear, clean the platen glass. (See Chapter 7, "Routine Maintenance," in the *Reference Guide*.)

---

The density of the documents sent to a remote machine is too light.

---

**Q** Is the Exposure setting set towards '□' (Light) and the Original Type setting set to 'Photo'?

**A** Change the Exposure setting to '▣' (Dark), the Original Type setting to 'Text'. Try sending the document again. (See "Scan Exposure and Original Type Settings," on p. 3-13.)

---

The machine will not transmit using a subaddress (if the optional Super G3 FAX Board or Super G3 Multi-Line Fax Board is installed).

---

**Q** Are the subaddress and password of the remote machine specified correctly?

**A** Check to see if the machine has a subaddress function.

**A** Check with the remote party to see if the specified subaddress and the RX password at both this machine and the remote machine are the same.

**Q** Has trouble occurred in the remote machine?

**A** Check to make sure that the remote machine can receive documents. If it cannot, check to see whether the recipient's machine has been turned OFF, is out of recording paper, or has insufficient available memory.

**Q** Are the subaddress and password for the destination stored in the Address Book correct?

**A** Check the subaddress and password settings for the destination stored in the Address Book.

---

The remote machine is slow to switch over to the receiving mode, and errors always occur (if the optional Super G3 FAX Board or Super G3 Multi-Line Fax Board is installed).

---

**Q** Is a pause inserted in the fax number?

**A** If you are sending to a machine that is slow in switching over to fax receiving, insert a pause after the destination's fax number.

## Receiving Documents

---

The machine does not receive documents.

---

**Q** Does the machine have sufficient memory?

**A** Erase unnecessary documents and documents with errors from memory to increase the amount of available memory. (See "Erasing Received Documents," on p. 6-8, and Chapter 2, "Introduction to the Mail Box Functions," in the *Copying and Mail Box Guide*.)

**Q** Are network settings specified?

**A** Documents cannot be received if the appropriate network settings are not specified. Confirm this with your System Manager.

---

The machine does not receive documents (if the optional Super G3 FAX Board or Super G3 Multi-Line Fax Board is installed).

---

**Q** Is the RX password set in your machine?

**A** If Receive Password is set in Fax Settings in Communications Settings in System Settings (from the Additional Functions screen), documents can be received only from senders that use the correct password. Confirm this with your System Manager. (See "Fax Settings," on p. 11-7.)

---

Documents cannot be received in Confidential Fax Inboxes.

---

- Q** Are the forwarding conditions in Forwarding Settings in System Settings (from the Additional Functions screen) set correctly?
- A** Check the Forwarding Conditions, and inform the sender of those settings. (See "Forwarding Settings," on p. 11-22.)
- Q** Is Forwarding Settings set to 'On' using [Validate/Invalidate]?
- A** Forwarding Settings must be set to 'On' to be effective. (See "Forwarding Settings," on p. 11-22.)
- Q** Is there sufficient available memory?
- A** Erase unnecessary documents and documents with errors from memory to increase the amount of available memory. (See "Erasing Received Documents," on p. 6-8, and Chapter 2, "Introduction to the Mail Box Functions," in the *Copying and Mail Box Guide*.)
- A** Erase unnecessary documents from the Confidential Fax Inboxes. (See "Erasing Received Documents," on p. 6-8.)

---

Documents cannot be received in memory.

---

- Q** Is there sufficient available memory?
- A** Erase unnecessary documents and documents with errors from memory to increase the amount of available memory. (See "Erasing Received Documents," on p. 6-8, and Chapter 2, "Introduction to the Mail Box Functions," in the *Copying and Mail Box Guide*.)
- A** Erase unwanted documents from the Memory RX Inbox. (See "Erasing Received Documents," on p. 6-8.)

---

The quality of printed originals is uneven.

---

- Q** Is the platen glass of the sender's machine clean?
- A** Make a few copies using your machine. If the copies are not streaked, the problem is in the sending party's machine. Contact the sender and ask them to send the document again.



## Other Situations

---

Transmissions are slow.

---

**Q** Are documents being sent at a high resolution?

**A** It is recommended that you send documents containing text only in a lower resolution. (See "Resolution," on p. 3-12.)

---

Fax transmissions are slow (if the optional Super G3 FAX Board or Super G3 Multi-Line Fax Board is installed).

---

**Q** Is the ECM TX or ECM RX set to 'On'?

**A** Set ECM TX and ECM RX to 'Off'. (See "ECM Transmission," on p. 9-43, and "ECM Reception," on p. 9-48.)

**Q** Was the original type set to 'Text/Photo' when sending the document?

**A** Select 'Text' from the Original Type drop-down list if the original does not contain any photos. (See "Scan Exposure and Original Type Settings," on p. 3-13).

---

Cannot use fax information services (if the optional Super G3 FAX Board or Super G3 Multi-Line Fax Board is installed).

---

**Q** If your machine is connected to a rotary pulse line, is your machine set for tone dialing?

**A** Set the machine for tone dialing to use fax information services. (See "Fax Information Services," on p. 7-8.)

**Q** Did you receive an instruction from the sender to set the machine to receive?

**A** Press [RX Start]. (See "Fax Information Services," on p. 7-8.)

---

Documents cannot be sent overseas (error code #18) (if the optional Super G3 FAX Board or Super G3 Multi-Line Fax Board is installed).

---

**Q** Is a pause inserted in the fax number?

**A** Insert a pause after the country code, or after the fax number of the recipient, and then dial the number again. (See "Specifying a Fax Number," on p. 2-2.)

**A** Change the Long Distance setting on the Option screen if you are sending documents to destinations stored in the Address Book. To access the Long Distance setting, press **Ⓢ** (Additional Functions) → [Address Book Settings] → [Register Address] → [Register New Address] → [Fax] → [Option]. (See "Editing Address Details," on p. 10-30.)

---

Calls are not connected, or an incorrect number is dialed.

---

**Q** Did you hear the dial tone before entering the fax number?

**A** Make sure that you hear the dial tone before entering the fax number. If you enter the fax number before hearing the dial tone, the call may not be connected, or an incorrect number may be dialed.

# Error Messages

This section explains the various messages that appear on the touch panel display, along with possible causes and remedies.

For explanations of messages that are not listed here, see the *Reference Guide* and *Network Guide*.

## Self-Diagnostic Display

Perform the necessary procedures according to the displayed self-diagnostic error message.

Self-diagnostic error messages appear on the touch panel display at the following times:

- When scanning or printing cannot be performed because of an operational error
- When you need to make a decision or take some action during scanning or printing
- When you need to make a decision or take some action while browsing the network

The following is a list of self-diagnostic error messages, along with their possible causes and remedies.

---

Out of resources. Wait for a moment, then perform operation again.

---

**Cause** You cannot browse the network. There is a lack of TCP/IP resources because documents have just been continuously sent or are being continuously sent via FTP or Windows (SMB).

**Remedy** Wait for a while, and try browsing again.

---

Set the IP Address.

---

**Cause** This machine is not set with an IP address.

**Remedy** Specify the IP Address Settings in TCP/IP Settings in Network Settings in System Settings (from the Additional Functions screen), turn the machine's main power OFF, and then back ON.

---

No response from the server. Check the settings.

---

**Cause** The specified server settings are incorrect, or the server is not turned ON. Alternatively, the machine's TCP/IP resources may be low.

**Remedy** Wait for a while, and then try browsing again. If there is still no response from the server, try selecting another server.

---

NetWare is in use. Wait for a moment, then perform operation again.

---

**Cause** You cannot browse the network because NetWare is printing through a PServer or NDS PServer.

**Remedy** Wait until printing is complete, and then try browsing again.

---

There are too many subdirectories.

---

**Cause** You have exceeded the maximum number of subdirectory levels allowed.

**Remedy** Specify a different destination because the directory level that you are trying to access cannot be specified.

---

No response.

---

**Cause 1** The server was not running when you tried to send.

**Remedy** Make sure that the server is ON, and check the destination.

**Cause 2** The network connection was lost when you tried to send. (Either you could not connect to the destination, or the connection was lost before the job could be completed.)

**Remedy** Check the status of the network.

**Cause 3** You tried to send via NetWare, but the Tree name was not entered.

**Remedy** Enter the Tree name.

**Cause 4** A TCP/IP error occurred when you tried to send an e-mail message or I-fax.

**Remedy** Check that the network cables and connectors are properly connected.

---

Check the TCP/IP.

---

**Cause** The machine's TCP/IP connection is not operating.

**Remedy** Check the IP Address Settings (IP Address, DHCP, RARP, BOOTP) in TCP/IP Settings in Network Settings in System Settings (from the Additional Functions screen). (See Chapter 3, "Using a TCP/IP Network," in the *Network Guide*.)

---

---

Cannot find the selected server. Check the settings.

---

**Cause 1** The IP address that the machine should connect to cannot be determined.

**Remedy 1** Check the DNS Server Settings in TCP/IP Settings in Network Settings in System Settings (from the Additional Functions screen). (See Chapter 3, "Using a TCP/IP Network," in the *Network Guide*.)

**Remedy 2** Check whether the DNS server's DNS settings are correct.

**Cause 2** If <Login Information> in Register LDAP Server in System Settings (from the Additional Functions screen) is set to 'Use (security auth.)' for the LDAP server, the machine will not be able to determine the host name.

**Remedy** Check the DNS Server Settings in TCP/IP Settings in Network Settings in System Settings (from the Additional Functions screen). (See Chapter 3, "Using a TCP/IP Network," in the *Network Guide*.)

---

Cannot connect to the selected server. Check the settings.

---

**Cause** The machine cannot connect to the specified IP address/port.

**Remedy 1** Check the Gateway Address setting in IP Address Settings in TCP/IP Settings in Network Settings in System Settings (from the Additional Functions screen). (See Chapter 3, "Using a TCP/IP Network," in the *Network Guide*.)

**Remedy 2** Check the Server Address and Port Number in Register LDAP Server in System Settings (from the Additional Functions screen). (See "Registering an LDAP Server," on p. 11-43.)

**Remedy 3** Check whether the LDAP server is operating normally.

**Remedy 4** If <Login Information> in Register LDAP Server in System Settings (from the Additional Functions screen) is set to 'Use (security auth.)' for the LDAP server, check whether UDP (User Datagram Protocol) packages are blocked by the filter.

---

Check the user name and password or check settings.

---

**Cause 1** When setting Login Information for the LDAP server to 'Use' or 'Use (security auth.)', the user name or password is incorrect.

**Remedy** Check the User Name and Password settings when <Login Information> in Register LDAP Server in System Settings (from the Additional Functions screen) is set to 'Use' or 'Use (security auth.)'. (See "Registering an LDAP Server," on p. 11-43.)

**Cause 2** When setting Login Information for the LDAP server to 'Use (security auth.)', the domain name is incorrect.

**Remedy** Check the Domain Name setting when <Login Information> in Register LDAP Server in System Settings (from the Additional Functions screen) is set to 'Use (security auth.)'. (See "Registering an LDAP Server," on p. 11-43.)

---

Cannot complete searching due to timeout. Check the settings.

---

**Cause** The search could not be completed within the time specified under <Search Timeout>.

**Remedy** Increase the time setting for Search Timeout in Register LDAP Server in System Settings (from the Additional Functions screen). (See "Registering an LDAP Server," on p. 11-43.)

---

The number of search results has exceeded limits. Change search conditions and try again.

---

**Cause** The number of addresses that meet the search criteria exceeds the specified maximum number of addresses to search.

**Remedy 1** Narrow down the search criteria, and then search again.

**Remedy 2** Increase the maximum number of addresses to search. (See "Registering an LDAP Server," on p. 11-43.)

---

Search condition includes characters that cannot be used with the selected server.

---

**Cause 1** "\" is used in the search criterion.

**Remedy** Remove "\" from the search criterion, and then search again.

**Cause 2** The combination of characters used in the search criterion does not constitute an acceptable search criterion.

- There is an unequal number of "(" and ")".
- "\*" is not placed within "( )".

**Remedy** Make sure that the characters for the search criterion are combined properly, and then search again.

**Cause 3** If <Server LDAP version and character code> is set to 'ver.2 (JIS)', characters other than ASCII Code (0x20-0x7E) are being used.

**Remedy** Omit characters that cannot be used, and then search again.

---

Cannot start searching because the version setting for the server is incorrect. Check the settings.

---

**Cause** Although 'ver. 3' is set as the server LDAP version number in Register LDAP Server in System Settings (from the Additional Functions screen), the LDAP server is running on version 2.

**Remedy** Set Server LDAP version and character code in Register LDAP Server in System Settings (from the Additional Functions screen) to 'ver. 2'. (See "Registering an LDAP Server," on p. 11-43.)

## List of Error Codes without Messages

If an error occurs while a document is being sent or received, an error code is displayed on the job log in the System Monitor screen, and is included in various reports. Check what the error code is, and then take the required steps to solve the problem. (See "Report and List Samples," on p. 14-2, and Chapter 9, "Checking/Changing the Send/Receive Status.")

 **NOTE**

If a send job is canceled, <STOP> is printed in the Results column on the Send report.

---

### # 001

---

**Cause 1** Originals are jammed in the paper supply opening of the feeder.

**Remedy** Check the originals and scan settings, and then try scanning again.

**Cause 2** Different sized originals were scanned without setting the Different Size Originals mode.

**Remedy** Set the Different Size Originals mode, and then try scanning again.

**Cause 3** Different sized originals were scanned in the 2-Sided Original without setting the Different Size Originals mode.

**Remedy** Set the Different Size Originals mode, and then try scanning again.

---

### # 003

---

**Cause** Communications that take longer than the preset time (64 minutes) caused the error.

**Remedy 1** Reduce the resolution or divide the document into two or more parts, and then try sending the document again. (See "Resolution," on p. 3-12.)

**Remedy 2** When receiving a document, ask the remote party to either reduce the resolution at which the document is scanned, or divide the document into two or more parts before sending it.

---

### # 005

---

**Cause 1** The recipient did not answer within 35 seconds.

**Remedy** Confirm that the recipient's machine is able to communicate, and then try again.

**Cause 2** The receiving machine is not a G3 fax.

**Remedy** Check the type of machine that the recipient has.



---

# 009

---

**Cause 1** There is no paper.

**Remedy** Load paper. (See Chapter 7, "Routine Maintenance," in the *Reference Guide*.)

**Cause 2** The paper drawer is not correctly inserted into the machine.

**Remedy** Insert the paper drawer properly.

---

# 011

---

**Cause** The document that you are sending is not placed correctly.

**Remedy** Place the document properly into the feeder or on the platen glass, and try sending again.

---

# 012

---

**Cause** The document could not be sent because the receiving fax machine was out of paper.

**Remedy** Ask the recipient to load paper into their fax machine.

---

# 018

---

**Cause 1** The recipient's machine did not respond when your machine redialed.

**Remedy** Confirm that the recipient's machine is able to communicate, and then try again.

**Cause 2** The documents could not be sent because the recipient's machine was performing another task.

**Remedy** Confirm that the recipient's machine is able to communicate, and then try again.

**Cause 3** The settings on your machine do not match the settings on the recipient's machine.

**Remedy** Check that the settings on your machine match those on the recipient's machine, and that the recipient's machine is able to communicate, and try again.

---

---

# 022

---

**Cause 1** Forwarding could not be performed because all of the addresses stored in the specified group destination have been deleted, or User Inboxes are specified as the group destination.

**Remedy** Re-enter group destination, and try sending again.

**Cause 2** Transmission could not be performed because the specified destination was deleted while the documents were waiting to be sent.

**Remedy** Re-enter the destination in the Address Book, and try sending again.

**Cause 3** Transmission via fax driver is not allowed.

**Remedy** Allow Fax Driver TX in Restrict the Send Function in System Settings (from the Additional Functions screen) is set to 'Off'. Set Allow Fax Driver TX to 'On'.

---

#037

---

**Cause** Data that contains more than 1,000 pages is received.

**Remedy** This machine can print or store up to 999 pages of data in memory, but will delete any data that exceeds this limit. Ask the sender to resend the remaining pages.

---

# 080

---

**Cause** A subaddress is not set in the recipient's machine.

**Remedy** Try sending the document without a subaddress, or request that the recipient set the same subaddress as the sender's subaddress.

---

# 081

---

**Cause** A password is not set in the recipient's machine.

**Remedy** Try sending the document without a password, or request that the recipient set the same password as the sender's password.

---

# 102

---

**Cause** The subaddress and/or password do not match.

**Remedy** Check the subaddress and/or password of the recipient's machine, make sure that the subaddress and password you are sending with the document matches the recipient's, and then try again.

---

## # 107

---

**Cause** The document could not be sent because there was insufficient memory available.

**Remedy 1** Resend the document at a lower resolution.

**Remedy 2** Erase unnecessary documents to make more memory available.

**Remedy 3** If this problem occurs frequently, contact your local authorized Canon dealer.

---

## # 701

---

**Cause 1** The specified Department ID does not exist, or the password has changed.

**Remedy** Enter the correct Department ID or password using **0** - **9** (numeric keys) on the control panel, and then try sending again.

**Cause 2** The Department ID or password was changed during the job, or <Allow Printer Jobs with Unknown IDs> in Dept. ID Management in System Settings (from the Additional Functions screen) is set to 'Off'.

**Remedy** Contact your System Manager.

---

## # 702

---

**Cause** The document could not be sent because the memory is full.

**Remedy 1** Wait a few moments, and then try again after the other send jobs complete.

**Remedy 2** Do not send the document to too many recipients at the same time. Send the document to a smaller number of recipients.

---

## # 703

---

**Cause** The memory for the image data is full.

**Remedy 1** Wait a few moments, and then try again after the other send jobs are complete.

**Remedy 2** Erase documents stored in inboxes. If the machine still does not operate normally, turn the main power OFF, and then back ON. (See Chapter 1, Before You Start Using This Machine, in the *Reference Guide*.)

---

---

**# 704**

---

**Cause** An error occurred while reading address information from the Address Book.

**Remedy** Check the address settings. If the machine still does not operate normally, turn the main power OFF, and then back ON. (See Chapter 1, Before You Start Using This Machine, in the *Reference Guide*.)

---

**# 705**

---

**Cause** The send operation was interrupted because the size of the image data is larger than the Maximum Data Size for Sending set in E-mail/I-Fax Settings in Communications Settings in System Settings (from the Additional Functions screen).

**Remedy** Change the Maximum Data Size for Sending setting in E-mail/I-Fax Settings in Communications Settings in System Settings (from the Additional Functions screen). Select a lower resolution, or if you are using I-fax, decrease the number of pages containing images that you are sending each time, so that you do not exceed the Maximum Data Size for Sending limit.

---

**# 706**

---

**Cause** The Address Book is being imported or exported from the Remote UI, or it is being used by another sending component.

**Remedy** Wait until the Address Book Import/Export function from the Remote UI or the other sending component is complete, and then try sending again.

---

**# 711**

---

**Cause** The inbox memory is full.

**Remedy** Erase the unnecessary documents stored in the inbox. (See "Erasing Received Documents," on p. 6-8, and Chapter 2, "Introduction to the Mail Box Functions," in the *Copying and Mail Box Guide*.)

---

**# 712**

---

**Cause** The maximum number of documents is already stored in the inbox.

**Remedy** Erase the unnecessary documents stored in the inbox. (See "Erasing Received Documents," on p. 6-8, and Chapter 2, "Introduction to the Mail Box Functions," in the *Copying and Mail Box Guide*.)

---

**# 713**

---

**Cause** The document in the inbox was deleted before its link was sent via e-mail.

**Remedy** Store the necessary document in the inbox again, and then try to send the link via e-mail.

---

**# 751**

---

**Cause** The server is not functioning. The network is down (the server is unable to connect to the network or was disconnected).

**Remedy** Check the recipient's address. Check that the network is up.

---

**# 752**

---

**Cause** The SMTP server name for e-mail or I-fax is not correct, or the server is not functioning.  
The domain name or e-mail address may not be set.  
The network is down.

**Remedy** Check the SMTP Server name, domain name, and E-mail Address in E-mail/I-Fax in Network Settings in System Settings (from the Additional Functions screen). Check that the SMTP server is operating properly. Check the network status.

---

**# 753**

---

**Cause** A TCP/IP error occurred while sending an e-mail message. (Socket, Select error, etc.)

**Remedy** Check the network cables and connectors. If the machine still does not operate normally, turn the main power OFF, and then back ON. (See Chapter 1, Before You Start Using This Machine, in the *Reference Guide*.)

---

**# 754**

---

**Cause** The server is not functioning or the network is down. The destination setting is not correct.

**Remedy** Check the server and network. Check the destination's address settings.

---

---

# 755

---

**Cause 1** You cannot send jobs because TCP/IP is not functioning correctly.

**Remedy** Check TCP/IP Settings in Network Settings in System Settings (from the Additional Functions screen).

**Cause 2** The IP address is not set.

**Remedy** Check TCP/IP Settings in Network Settings in System Settings (from the Additional Functions screen).

**Cause 3** When the machine was turned ON, an IP address was not assigned to the machine by the DHCP, RARP, or BOOTP server.

**Remedy** Check TCP/IP Settings in Network Settings in System Settings (from the Additional Functions screen).

---

# 756

---

**Cause** NetWare in NetWare Settings in Network Settings in System Settings (from the Additional Functions screen) is set to 'Off'.

**Remedy** Turn NetWare 'On'.

---

# 761

---

**Cause** A PDF with a digital signature could not be sent because a digital certificate or key pair registered in the machine is corrupt or could not be accessed.

**Remedy 1** If you are sending a PDF with a user signature, confirm that the user certificate is not corrupt. If the user certificate is corrupt, re-install it. (See Chapter 3, "Using a TCP/IP Network," in the *Network Guide*.)

**Remedy 2** If you are sending a PDF with a device signature, confirm that the device certificate is not corrupt. If the device certificate is corrupt, generate it again. (See Chapter 3, "Using a TCP/IP Network," in the *Network Guide*.)

---

# 766

---

**Cause** The certificate used to send a PDF with a digital signature has expired.

**Remedy 1** Update the certificate, or use a certificate which has not expired.

**Remedy 2** Set the date and time of the machine to the correct date and time.

---

---

## # 770

---

**Cause** Data could not be sent with WebDAV, because the WebDAV server or proxy server does not support SSL communications.

**Remedy 1** Check the settings of the WebDAV server.

**Remedy 2** Check the proxy server if you are communicating via a proxy server.

---

## # 801

---

**Cause 1** A timeout error occurred while the machine was communicating with the SMTP server to send an e-mail message or send/receive an I-fax.

**Remedy** Check that the SMTP server is functioning normally. Check the network status.

**Cause 2** The SMTP server returned an error while trying to connect. The destination is not correct. An error occurred on the server side during transmission to a file server.

**Remedy** Check that the SMTP server is functioning normally. Check the network status. Check the destination setting. Check the status and setting of the file server.

**Cause 3** You are sending a file to a destination to which you have no write permission.

**Remedy** Check the destination setting.

**Cause 4** When the machine tried to send a file to the server, a file with the same name already exists on the FTP server and that file cannot be overwritten.

**Remedy** Change the setting on the file server to enable the file to be overwritten.

**Cause 5** When the machine tried to send a file to the server, either the folder name is incorrectly specified or the password is incorrect.

**Remedy** Check the destination setting.

---

**# 802**

---

**Cause** The name of the SMTP Server in E-mail/I-Fax settings in Network Settings in System Settings (from the Additional Functions screen) is incorrect.  
The DNS server name in DNS Server Settings in TCP/IP Settings in Network Settings in System Settings (from the Additional Functions screen) is incorrect. (See Chapter 3, "Using a TCP/IP Network," in the *Network Guide*.)  
Connection to the DNS server failed.

**Remedy** Check the name of the SMTP Server in E-mail/I-Fax Settings in Network Settings in System Settings (from the Additional Functions screen).  
Check the DNS server name in DNS Server Settings in TCP/IP Settings in Network Settings in System Settings (from the Additional Functions screen).  
Check that the DNS server is functioning normally.

---

**# 803**

---

**Cause** The connection was interrupted due to reasons on the recipient's side before all of the pages could be sent.

**Remedy** Try sending again.

---

**# 804**

---

**Cause 1** Unable to match the specified directory name when sending data to a file server.

**Remedy** Check the destination.

**Cause 2** You have no permission to access the folder.

**Remedy** Change the setting on the server to enable access to the folder.

---

**# 806**

---

**Cause 1** An incorrect user name or password was specified for the sending of a file to a file server.

**Remedy** Change the user name or password. (See "Specifying Registered Destinations," on p. 2-23.)

**Cause 2** An incorrect destination was specified for the sending of an e-mail message or I-fax.

**Remedy** Check the e-mail or I-fax address.



---

**# 810**

---

**Cause 1** A POP (Post Office Protocol) server connection error occurred while receiving an I-fax.

**Remedy** Check the POP Server name in E-mail/I-Fax in Network Settings in System Settings (from the Additional Functions screen). Confirm that the POP server is functioning normally. Check the network status.

**Cause 2** The POP server returned an error during the connection.

**Remedy** Check the POP Server name in E-mail/I-Fax in Network Settings in System Settings (from the Additional Functions screen). Confirm that the POP server is functioning normally. Check the network status.

**Cause 3** A timeout error occurred on the server while connecting to the POP server.

**Remedy** Check the POP Server name in E-mail/I-Fax in Network Settings in System Settings (from the Additional Functions screen). Confirm that the POP server is functioning normally. Check the network status.

---

**# 815**

---

**Cause** You cannot log on to the file server because the machine is printing a document sent to that server. Simultaneous connections are not possible.

**Remedy** Wait for a few moments before trying to send the data again, or change the NetWare server to which you are sending your documents. Alternatively, stop the PServer.

---

**# 818**

---

**Cause** The received data is not in a printable file format.

**Remedy** Ask the sender to change the file format and resend the data.

---

**# 819**

---

**Cause** You have received data that cannot be processed (MIME information is incorrect).

**Remedy** Check the settings, and ask the sender to resend the data.

---

**# 820**

---

**Cause** You have received data that cannot be processed (BASE 64 or uuencode is incorrect).

**Remedy** Check the settings, and ask the sender to resend the data.

---

**# 821**

---

**Cause** You have received data that cannot be processed (TIFF analysis error).

**Remedy** Check the settings, and then ask the sender to resend the data.

---

**# 822**

---

**Cause** You have received data that cannot be processed (image data cannot be decoded).

**Remedy** Check the settings, and then ask the sender to resend the data.

---

**# 827**

---

**Cause** You have received data that cannot be processed (contains MIME information that is not supported).

**Remedy** Check the settings, and then ask the sender to resend the data.

---

**# 828**

---

**Cause** You have received HTML data.

**Remedy** Ask the sender to use a file format other than HTML, and then resend the data.

---

**# 829**

---

**Cause** Data that contains more than 1,000 pages is received.

**Remedy** This machine can print or store up to 999 pages of data in memory, but will delete any data that exceeds this limit. Ask the sender to resend the remaining pages.

---

---

**# 830**

---

**Cause** A DSN (Delivery Status Notification) error notification is received because of an incorrect I-fax address or destination setting, or because the data size of the sent documents exceeds the mail server capacity.

**Remedy 1** Check the I-fax address or destination setting.

**Remedy 2** Set Maximum Data Size for Sending in E-mail/I-Fax Settings in Communications Settings in System Settings (from the Additional Functions screen) so that it is less than the mail server capacity.

**Remedy 3** Check the status of the mail server, DNS server, and network.

---

**# 831**

---

**Cause** An I-fax document could not be received using SMTP because of the RX/Print Range setting in IP Address Settings in TCP/IP Settings in Network Settings in System Settings (from the Additional Functions screen).

**Remedy** Reset the RX/Print Range setting in IP Address Settings in TCP/IP Settings in Network Settings in System Settings (from the Additional Functions screen).

---

**# 832**

---

**Cause** DSN (Delivery Status Notification) mail was not sent because TCP/IP Settings or E-mail/I-Fax in Network Settings in System Settings (from the Additional Functions screen) have not been set, or because trouble has occurred in the mail server.

**Remedy 1** Check the DNS Server Settings and IP Address Settings in TCP/IP Settings, and E-mail/I-Fax in Network Settings in System Settings (from the Additional Functions screen).

**Remedy 2** Check the status of the mail server and DNS server.

---

**# 833**

---

**Cause** MDN (Mail Delivery Notification) mail was not sent because TCP/IP Settings or E-mail/I-Fax in Network Settings in System Settings (from the Additional Functions screen) have not been set, or because trouble has occurred in the mail server.

**Remedy 1** Check the DNS Server Settings and IP Address Settings in TCP/IP Settings, and E-mail/I-Fax in Network Settings in System Settings (from the Additional Functions screen).

**Remedy 2** Check the status of the mail server and DNS server.

---

---

# 834

---

**Cause** An MDN (Mail Delivery Notification) error notification is received because of an incorrect I-fax address or destination setting, or because trouble has occurred in the network or mail server. Alternatively, the memory of the receiving machine is full.

**Remedy** Check the I-fax address and destination settings.

---

# 835

---

**Cause** The maximum number of text lines for receiving an I-fax has been exceeded.

**Remedy** Ask the sender to reduce the amount of text data in the body of the document, and then resend the data.

---

# 837

---

**Cause** A connection request was received from a host whose connection is restricted by IP Address Settings.

**Remedy** Check the settings in IP Address Settings in TCP/IP Settings in Network Settings in System Settings (from the Additional Functions screen). Make sure that the connection request is made from an authorized host.

---

# 839

---

**Cause** The user name or password for the SMTP authentication (SMTP AUTH) in Authent./Encryption in E-mail/I-Fax in Network Settings in System Settings (from the Additional Functions screen) is incorrect.

**Remedy** Check the user name and password for SMTP Authentication (SMTP AUTH) in Authent./Encryption in E-mail/I-Fax in Network Settings in System Settings (from the Additional Functions screen). (See Chapter 3, "Using a TCP/IP Network," in the *Network Guide*.)

---

# 841

---

**Cause** The encryption algorithm that matches the mail server does not exist for sending e-mail or I-fax.

**Remedy 1** Set Allow SSL in Network Settings in System Settings (from the Additional Functions screen) to 'Off'. (See Chapter 3, "Using a TCP/IP Network," in the *Network Guide*.)

**Remedy 2** Add the same encryption algorithm as the mail server in the mail server settings.

---

---

**# 842**

---

**Cause** Authentication using the client certificate was requested by the mail server for sending an e-mail message or I-fax.

**Remedy 1** Set Allow SSL in Network Settings in System Settings (from the Additional Functions screen) to 'Off'. (See Chapter 3, "Using a TCP/IP Network," in the *Network Guide*.)

**Remedy 2** Change the mail server settings so that the client certificate is not requested.

---

**# 843**

---

**Cause** There is large difference between the current time set in the KDC (Key Distribution Center) server and the time set in the machine.

**Remedy 1** Change the current date and time in Date & Time Settings in System Settings (from the Additional Functions screen). (See Chapter 6, "System Manager Settings," in the *Reference Guide*.)

**Remedy 2** Change the current time set in the KDC (Key Distribution Center) server.

---

**# 847**

---

**Cause** Could not save the received document in the Confidential Fax Inbox, as the memory of the Confidential Fax Inbox is full.

**Remedy** Erase unnecessary documents stored in the Confidential Fax Inbox or the Memory RX Inbox. (See Chapter 2, "Introduction to the Mail Box Functions," in the *Copying and Mail Box Guide*.)

---

---

# 851

---

**Cause 1** There is insufficient memory remaining in the system.

**Remedy** Check the system's available memory, and delete unnecessary documents in the inboxes. (See "Erasing Received Documents," on p. 6-8, and Chapter 2, "Introduction to the Mail Box Functions," in the *Copying and Mail Box Guide*.)

**Cause 2** The scanned document cannot be stored because there are more than 1,500 documents or 6,000 pages in the specified inbox.

**Remedy** Delete unnecessary documents from the specified inbox.

**Cause 3** The memory for image data is full.

**Remedy** Erase unnecessary documents and documents with errors from memory to increase the amount of available memory. (See "Erasing Received Documents," on p. 6-8, and Chapter 2, "Introduction to the Mail Box Functions," in the *Copying and Mail Box Guide*.)

---

# 852

---

**Cause** An error occurred because the main power switch was turned OFF while a job was being processed.

**Remedy** Check to see if the main power switch is turned ON. Try processing the job again, if necessary. (See Chapter 1, Before You Start Using This Machine, in the *Reference Guide*.)

---

# 853

---

**Cause 1** The job could not be executed due to a lack of resources when trying to print a large number of pages.

**Remedy** Reduce the number of pages to print, or try printing again when no other print jobs are reserved.

**Cause 2** The job could not be executed because it was canceled from the printer driver while the print data was being sent from the computer to the machine.

**Remedy** Try printing again.

**Cause 3** Use Spooler is set to 'On' and data received from the host could not be spooled because the spool memory is full.

**Remedy** Set Use Spooler to 'Off', and try sending again. (See Chapter 3, "Using a TCP/IP Network," in the *Network Guide*).

**Cause 4** The maximum amount of data that can be received was exceeded when processing received data.

**Remedy** Try printing again after all current jobs are completed. If you still cannot print, check that the data being sent from the computer is not corrupt, and that it has not exceeded the maximum data size limit.

**Cause 5** The number of secured jobs exceeded the maximum limit that can be reserved at a time.

**Remedy** Print or erase the secured jobs that are stored in the machine, and then try printing again.

---

# 857

---

**Cause** Data reception timed out, or the job was canceled at the host.

**Remedy** Check that the network is functioning properly, and then try printing again.

---

# 858

---

**Cause** There is a problem with the print data sent from an external application.

**Remedy** Check the settings of the data sent to the machine, make sure they are compatible with the machine, and try sending the data again.

---

**# 859**

---

**Cause 1** A compression error occurred with the image data.

**Remedy** Check the print settings, and try printing again.

**Cause 2** An original was not scanned properly, or the orientation of the original was incorrect.

**Remedy** Check the scan settings, and try scanning again.

---

**# 860**

---

**Cause 1** A paper jam occurred during printing.

**Remedy** Try printing again.

**Cause 2** Recovery printing was not performed.

**Remedy** Try printing again.

**Cause 3** You tried to print on a transparency sheet made for color copies.

**Remedy** Load transparencies made for black-and-white copies into the machine and then try printing again.

---

**# 861**

---

**Cause 1** An error occurred while processing PDL data or image data.

**Remedy** Confirm the print settings you made when printing from a computer.

**Cause 2** Color data was sent from the external controller to the billing device as monochrome data.

**Remedy** Change the print data or print settings, and try printing again.



---

# 862

---

**Cause 1** The saddle finisher trays have exceeded their stacking limits. (See Chapter 9, Appendix, in the *Reference Guide*.)

**Remedy** Change the print data or print settings, and try printing again.

**Cause 2** A combination of settings which is not supported was set.

**Remedy** Change the print data or print settings, and try printing again.

**Cause 3** Image data or data which is not guaranteed to be compatible was printed.

**Remedy** Change the print data or print settings, and try printing again.

---

# 863

---

**Cause** An error occurred while processing PDL data or image data.

**Remedy** Check the settings, and try printing again.

---

# 864

---

**Cause 1** The external controller or controller board is not attached, or is not functioning properly.

**Remedy** Contact your System Manager.

**Cause 2** The external controller or controller board cannot be recognized correctly.

**Remedy** Contact your System Manager.

---

# 865

---

**Cause** The Mail Box function is restricted.

**Remedy** Contact your System Manager.

---

---

**# 868**

---

**Cause** Failed to communicate with the destination when sending with WebDAV, because access via a proxy server was requested (received HTTP Error 305: Use Proxy).

**Remedy 1** Check the settings of the WebDAV server.

**Remedy 2** Check Proxy Settings in TCP/IP Settings in Network Settings in System Settings (from the Additional Functions screen). (See Chapter 3, "Using a TCP/IP Network," in the *Network Guide*.)

---

**# 869**

---

**Cause** Received a response from the destination stating that authorization failed when sending with WebDAV (received HTTP Error 401: Unauthorized).

**Remedy 1** Check the user name and password for the destination.

**Remedy 2** Check the security settings of the WebDAV server.

---

**# 870**

---

**Cause** Received a response from the destination stating that the request was denied when sending with WebDAV (received HTTP Error 403: Forbidden).

**Remedy 1** Wait a few moments, and the try again.

**Remedy 2** Check the destination.

**Remedy 3** Check the settings of the WebDAV server.

---

**# 871**

---

**Cause** Received a response from the destination stating that the specified folder could not be found when sending with WebDAV (received HTTP Error 404: Not Found/409: Conflict/410: Gone).

**Remedy** Check the settings of the WebDAV server.

---

**# 872**

---

**Cause** Received a response from the destination stating that access is denied when sending with WebDAV (received HTTP Error 405: Method Not Allowed).

**Remedy** Check the settings of the WebDAV server.

---

**# 873**

---

**Cause** Received a response from the destination stating that proxy authentication failed when sending with WebDAV (received HTTP Error 407: Method Not Allowed).

**Remedy** Check Proxy Settings in TCP/IP Settings in Network Settings in System Settings (from the Additional Functions screen). (See Chapter 3, "Using a TCP/IP Network," in the *Network Guide*.)

---

**# 874**

---

**Cause** Received a response from the destination stating that the connection timed out when sending with WebDAV (received HTTP Error 408: Request Timeout).

**Remedy 1** Wait a few moments, and the try again.

**Remedy 2** Wait a few moments, and the try again.

---

**# 875**

---

**Cause** Received a response from the destination stating that chunked encoding was denied when sending with WebDAV (received HTTP Error 411: Length Required).

**Remedy 1** Set Use Chunked Encoding with WebDAV Sending in TX Settings under <Common Settings> in Communications Settings (from the Additional Functions screen) to 'Off'. (See "Dividing Data Into Chunks When Sending With WebDAV," on p. 9-31.)

**Remedy 2** Check the settings of the WebDAV server.

---

**# 876**

---

**Cause** Received a response from the destination stating that the size of the data was too large when sending with WebDAV (received HTTP Error 413: Request Entity Too Large).

**Remedy** Check the settings of the WebDAV server.

---

**# 877**

---

**Cause** Received a response from the destination stating that the URL (host name + folder path) was too long when sending with WebDAV (received HTTP Error 414: Request-URL Too Long).

**Remedy** Check the settings of the WebDAV server.

---

---

**# 878**

---

**Cause** Received a response from the destination stating that the server encountered an unexpected condition that prevented it from executing the request when sending with WebDAV (received HTTP Error 500: Internal Server Error).

**Remedy** Check the settings of the WebDAV server.

---

**# 879**

---

**Cause** Received a response from the destination stating that the server does not support the necessary functions to execute the request when sending with WebDAV (received HTTP Error 501: Not Implemented).

**Remedy 1** Check the settings of the WebDAV server.

**Remedy 2** If you are sending via a proxy server without using SSL communication, set Use Chunked Encoding with WebDAV Sending in TX Settings under <Common Settings> in Communications Settings (from the Additional Functions screen) to 'Off'. (See "Dividing Data Into Chunks When Sending With WebDAV," on p. 9-31.)

---

**# 880**

---

**Cause** Received a response from the destination stating that the proxy server failed to communicate with the server above it when sending with WebDAV (received HTTP Error 502: Bad Gateway).

**Remedy 1** Check the settings of the WebDAV server.

**Remedy 2** Check the settings of the proxy server.

---

**# 881**

---

**Cause** Received a response from the destination stating that the server could not handle the current request when sending with WebDAV (received HTTP Error 503: Service Unavailable).

**Remedy** Check the settings of the WebDAV server.

---

---

**# 882**

---

**Cause** Received a response from the destination stating that the proxy server failed to communicate with the server above it when sending with WebDAV (received HTTP Error 504: Gateway Timeout).

**Remedy 1** Check the settings of the WebDAV server.

**Remedy 2** Check the settings of the proxy server.

---

**# 883**

---

**Cause** Received a response from the destination stating that the server does not support the necessary functions to execute the request when sending with WebDAV (received HTTP Error 505: HTTP Version Not Supported).

**Remedy** Check the settings of the WebDAV server.

---

**# 884**

---

**Cause** Received a response from the destination stating that the server does not have sufficient free disk space to execute the request when sending with WebDAV (received HTTP Error 507: Insufficient Storage).

**Remedy** Check the settings of the WebDAV server.

---

**# 885**

---

**Cause** An unexpected error occurred when sending with WebDAV.

**Remedy 1** Check the settings of the WebDAV server.

**Remedy 2** Check the settings of the proxy server.

---

**# 886**

---

**Cause** Received a response from the destination stating that the request was invalid when sending with WebDAV (received HTTP Error 400: Bad Request).

**Remedy** If you are sending via a proxy server without using SSL communication, set Use Chunked Encoding with WebDAV Sending in TX Settings under <Common Settings> in Communications Settings (from the Additional Functions screen) to 'Off'. (See "Dividing Data Into Chunks When Sending With WebDAV," on p. 9-31.)

---

---

# 899

---

**Cause** The e-mail message or I-fax has been successfully sent, but reception may be incomplete because the transmission was relayed via multiple servers.

**Remedy 1** Confirm whether reception was completed.

**Remedy 2** Check if you received an error notification.

---

# 995

---

**Cause** Reserved communication jobs were cleared.

**Remedy** Reserve the jobs again, if necessary.

# Questions & Answers

---

**Q** Can the machine automatically resend documents when there are errors in transmission?

**A** If you are sending the document by any other sending method besides fax, specify the Retry Times setting. To access the Retry Times setting, press  (Additional Functions) → [Communications Settings] → [TX Settings] under <Common Settings> → [▼] → [Retry Times]. (See "Number of Retry Attempts," on p. 9-13.)

If you are sending the document by fax, set Auto Redial in TX Settings under <Fax Settings> in Communications Settings (from the Additional Functions screen). You can also make detailed settings, such as the redialing frequency and interval. (See "Auto Redial," on p. 9-45.)

---

**Q** What happens to documents that are sent to my machine while the power switch on the control panel is turned OFF?

**A** These documents are automatically stored and printed when all documents have been received.

---

**Q** What happens if fax/I-fax documents arrive when the machine is being used for copying?

**A** While you are making copies, the documents are automatically received and stored in the machine's memory, and will be printed automatically when you finish copying.

You can change the order in which these documents print. (See Chapter 4, "Customizing Settings," in the *Reference Guide*.)

---

**Q** I frequently send documents using the same settings. Can the machine be set to automatically restore those settings when the power is turned ON or after an operation completes?

**A** You can store the desired settings in a favorites button and recall them as needed. Alternatively, you can set the desired settings as the Standard Send Settings so that they are always specified when the machine is turned ON or after an operation completes.

---

**Q** What happens to received documents if a paper jam occurs while they are printing?

**A** If documents are not printed correctly, they are held in memory. When the paper jam is cleared, printing resumes from the page at which the paper jam occurred.

---

---

**Q** What happens to a document that has not been completely received when a blackout occurs?

**A** The document, up to the last page that was successfully received, is printed.

---

**Q** What happens to documents in memory and the memory settings if power is interrupted?

**A** Documents that are stored in the system's memory remain in memory even when power to the machine is interrupted. Similarly, the contents of the Address Book are also stored permanently in memory. However, if power is interrupted while a document is being received, it is not stored in memory. After the power is restored, the sender or mail server may resend the interrupted job. If the interrupted job was sent from a POP server as I-fax, since the job is stored in the POP server, the machine can receive it again.

---

**Q** How can I save paper?

**A** You can set for received documents to be printed on both sides of the paper. (See "2-Sided Printing," on p. 9-34.)

You can set for received documents to be forwarded to e-mail destinations, or receive documents in memory, and then send them to the desired destinations. (See "Forwarding Settings," on p. 11-22, and Chapter 2, "Introduction to the Mail Box Functions," in the *Copying and Mail Box Guide*.)

You can set the machine to not print reports. Two kinds of reports are printed when an error occurs while sending a fax, the Send TX Report and Fax TX Report. You can save paper by setting the machine to not print either one of these reports. (See "Specifying Report Settings," on p. 12-4.)

---

**Q** Can I turn the machine's power OFF if a document is set with the Delayed Send setting?

**A** When you are not using the machine, you may turn OFF the control panel power switch on the control panel, but leave the main power switch turned ON. Documents that are set with the Delayed Send setting are automatically sent from memory when the specified time arrives.



---

**Q** Can I change the data size of an e-mail message or I-fax before sending it?

**A** You can specify the Maximum Data Size for Sending setting according to your needs. To access this setting, press **Ⓢ** (Additional Functions) → [System Settings] → [Communications Settings] → [E-mail/I-Fax Settings]. For e-mail, the send job is split up into several e-mail messages before being sent, so that the data size of each e-mail message does not exceed the set limit. For I-fax, the send job cannot be sent if the data size exceeds the set limit when <Send Via Server> is set to 'On'. However, when <Send Via Server> is set to 'Off', even if you enter the maximum data size for sending, there is no size limit on the data that is sent.

---

**Q** The result in the Activity Report shows "--." How can I tell if the document was successfully sent?

**A** "--" is displayed when sending is successful, but it is not confirmed whether the e-mail message or I-fax you sent, or the file that you sent to an imageWARE Document Manager folder, was actually delivered. Contact the recipient to check whether your document was received.



# Appendix

# 14

CHAPTER

This chapter provides the reports and lists of activity management, specifications, glossary, and index.

---

Report and List Samples . . . . .	14-2
Send Job List . . . . .	14-2
Send TX Report . . . . .	14-3
Fax TX Report/Fax Error TX Report . . . . .	14-5
Multiple Communication Result Report . . . . .	14-6
Fax RX Report . . . . .	14-8
Confidential Fax Inbox Reception Report . . . . .	14-9
Activity Report . . . . .	14-11
Fax Activity Report . . . . .	14-13
Forwarding Conditions List . . . . .	14-15
Registered LDAP Server List . . . . .	14-16
Address Book List . . . . .	14-17
User's Data List . . . . .	14-19
Specifications . . . . .	14-21
Universal Color Send . . . . .	14-21
Super G3 FAX Board . . . . .	14-23
Super G3 Multi-Line Fax Board . . . . .	14-24
Glossary . . . . .	14-25
Index . . . . .	14-39

# Report and List Samples

## NOTE

The fax numbers and addresses used in these sample reports are fictitious.

## Send Job List

You can view the list of send jobs and their statuses. The Send Job List can be printed from the System Monitor screen. (See "Printing the Send Job Status/Log," on p. 8-8.)

02/14/2006 TUE 16:39		IR C33801		001			
***** *** SEND JOB LIST *** *****							
SET TIME	ST. TIME	DESTINATION ADDRESS	DESTINATION ID	JOB NO.	MODE	PGS.	
02/14 15:49	22:00	tom@example.com 01 starfish.organization.c file share \\swan\share project	tom	0001	TX MAIL TX BOX TX FTP TX SMB		1
02/14 16:35	23:00	012XXXXXXX 01 098XXXXXXX Canon CANADA 011XXXXXXX Canon EUROPE	Canon U.S.A Canon CANADA Canon EUROPE	0002	TX FAX TX BOX TX FAX TX FAX		1

## NOTE

- A list of e-mail, I-fax, and file server transmissions is displayed.
- If the optional Super G3 FAX Board or Super G3 Multi-Line Fax Board is installed, a list of fax jobs in addition to the above mentioned jobs is displayed.

### ■ SET TIME

The date and time that the send job was specified is printed in 24-hour notation. If SDL or SSO is set as the login service, the user name used for login is displayed below the set time. When the machine cannot specify the user (for example, when automatically forwarding), the user name is not displayed.

### ■ ST. TIME (Start Time)

The time (in 24-hour notation) at which the document started to be transmitted is printed. The start time is printed only for send jobs that have been set with the Delayed Send setting.

### ■ DESTINATION ADDRESS

The address of the recipient is printed.

■ **DESTINATION ID**

The name of the recipient is printed.

■ **JOB NO.**

The four digit number, that is automatically assigned when the document is accepted for sending, is printed.

■ **MODE**

The type and mode of transmission are printed.

Transmission type: Send (TX)

Mode of transmission: FTP, SMB, IPX, WebDAV, User Inbox (BOX), I-Fax (I-FAX), E-mail (MAIL), Fax (FAX)

■ **PGS.**

The number of pages that were sent successfully to the remote party is printed.

 **NOTE**

If a field exceeds its display capacity, only those characters that fit in the display are printed.

## Send TX Report

The Send TX Report is a printed report that informs you of whether a send job has been successfully delivered to its destination. A Send TX Report can be set to print automatically after each job is sent, or only when there are transmission errors. (See "Send TX Report," on p. 12-4.)

```

02/14/2006 TUE 15:30                                iR_C3380i                                001
*****
*** TX REPORT ***
*****
JOB NO.                0108
DEPT. ID              1234
ST. TIME              02/14 15:30
PGS.                  1
SEND DOCUMENT NAME
TX/RX INCOMPLETE     -----
TRANSACTION OK       tom
ERROR                BOX 01                tom@example.com
                   file share
                   project                starfish.organization.com
                                           \\swan\share

```

 **NOTE**

- The results of e-mail, I-fax, file server, and User Inbox transmission can be printed. Even if <Report with TX Image> is set to 'On', the contents of the sent document are not printed on the report in the following cases:
  - If the first page of the original is color, and <Report with Color TX Image> is set to 'Off'
  - If the document was sent using the Encrypted PDF mode
- If the optional Super G3 FAX Board or Super G3 Multi-Line Fax Board is installed, the results of fax transmissions in addition to the above mentioned transmissions are printed.

**■ JOB NO.**

The four digit number, that is automatically assigned when the document is accepted for sending, is printed.

**■ DEPT. ID**

If Department ID Management is set, the Department ID is printed.

**■ ST. TIME (Start Time)**

The date and time (in 24-hour notation) at which the document started to transmit are printed.

**■ PGS.**

The number of pages that were sent successfully to the recipient is printed.

**■ SEND DOCUMENT NAME**

The name given to the document when the send settings were specified is printed.

**■ TX/RX INCOMPLETE**

If the transmission has been interrupted, the name and address of the destination are printed.

**■ TRANSACTION OK**

If the transmission completed successfully, the name and address of the destination are printed.

**■ ERROR**

If a sending error occurs, the name and address of the destination are printed.

 **NOTE**

If a field exceeds its display capacity, only those characters that fit in the display are printed.

# Fax TX Report/Fax Error TX Report

This report indicates items, such as the fax number of the party to which you sent documents, the result of communication, and other information, to enable you to check whether the documents were sent correctly to the intended destination.

You can set whether to automatically print a Fax TX Report after sending documents. (See "Fax TX Report," on p. 12-7.)

```
02/14/2006 TUE 13:43   FAX 012XXXXXXX   iR C3380i   001
*****
*** FAX TX REPORT ***
*****
TRANSMISSION OK
JOB NO.                0024
DEPT. ID               1
DESTINATION ADDRESS    098XXXXXXX
PSWD/SUBADDRESS
DESTINATION ID        Canon
ST. TIME               02/14 13:42
USAGE T               00'08
PGS.                   1
RESULT                 OK
```

## NOTE

- This mode is available only if the optional Super G3 FAX Board or Super G3 Multi-Line Fax Board is installed.
- You can also print a Fax TX Report with an image of the sent original attached to it. (See "Fax TX Report," on p. 12-7.)

## ■ REPORT NAME

When the document transmission is completed successfully, a Fax TX Report is printed. When a send error occurs, a Fax Error TX Report is printed.

## ■ MESSAGE

A message describing the transmission result is printed.

## ■ JOB NO.

The four digit number, that is automatically assigned when the document is accepted for sending, is printed.

## ■ DEPT. ID

If Department ID Management is set, the Department ID is printed.

## ■ DESTINATION ADDRESS

The fax number of the destination is printed, up to the first 20 digits.

■ **PSWD/SUBADDRESS**

A subaddress is printed, if specified. The password is not printed to maintain security.

■ **DESTINATION ID**

The name of the remote party is printed.

■ **ST. TIME (Start Time)**

The date and time (in 24-hour notation) at which the document started to transmit are printed.

■ **USAGE T**

The time taken (in minutes and seconds) to send the document from start to finish is printed.

■ **PGS.**

The number of pages that were sent successfully to the recipient is printed.

■ **RESULT**

If the documents were transmitted successfully, "OK" is printed.

If a sending error occurred, "NG" (No Good) is printed.

If a sending error occurred, the page number in which the error occurred and the error code number are printed.

## Multiple Communication Result Report

This report is used to check whether documents were sent successfully to the intended destinations when a sequential broadcast transmission was performed.

You can set whether to automatically print a Multiple Communication Result Report after sending documents. (See "Fax TX Report," on p. 12-7.)

```
02/14/2006 TUE 11:18   FAX 012XXXXXXX           iR C3380i           001
*****
***  FAX MULTI TX REPORT  ***
*****
JOB NO.                0142
DEPT. ID              123
PGS.                  1
TX/RX INCOMPLETE     012XXXXXXX
TRANSACTION OK        -----
ERROR                 098XXXXXXX
```



 **NOTE**

- This mode is available only if the optional Super G3 FAX Board or Super G3 Multi-Line Fax Board is installed.
- You can also print a Multi TX/RX Report with an image of the sent original attached to it. (See "Fax TX Report," on p. 12-7.)

■ **JOB NO.**

The four digit number, that is automatically assigned when the document is accepted for sending, is printed.

■ **DEPT. ID**

If Department ID Management is set, the Department ID is printed.

■ **PGS.**

The number of pages that were sent successfully to the destinations is printed.

■ **TX/RX INCOMPLETE**

If a transmission is incomplete, the fax number and the name of the destination are printed. If there is no applicable destination, " \_ \_ \_ " is printed.

■ **TRANSACTION OK**

The fax number and the name of the destination of a completed transmission are printed. If there is no applicable destination, " \_ \_ \_ " is printed.

■ **ERROR**

If an error in transmission occurs, the fax number and the name of the destination are printed. If there is no applicable destination, " \_ \_ \_ " is printed.

# Fax RX Report

This report is used to check if documents were received successfully by this machine.

You can set whether to automatically print a Fax RX Report. (See "Fax RX Report," on p. 12-9.)

02/14/2006 TUE 13:03	FAX 012XXXXXXX	iR C3380i	001
***** *** FAX RX REPORT *** *****			
RECEPTION OK			
JOB NO.	5002		
DESTINATION ADDRESS	012XXXXXXX		
PSWD/SUBADDRESS			
DESTINATION ID	Canon		
ST. TIME	02/14 13:02		
USAGE T	00'14		
PGS.	1		
RESULT	OK		

## NOTE

This mode is available only if the optional Super G3 FAX Board or Super G3 Multi-Line Fax Board is installed.

### ■ MESSAGE

A message describing the reception result is printed.

### ■ JOB NO.

The four digit number, that is automatically assigned when the document is accepted for receiving, is printed.

### ■ DESTINATION ADDRESS

The fax number of the sender is printed, up to the first 20 digits.

### ■ PSWD/SUBADDRESS

A subaddress is printed, if specified. The password is not printed to maintain security.

### ■ DESTINATION ID

The name of the sender is printed.

### ■ ST. TIME (Start Time)

The date and time (in 24-hour notation) at which the document started to be received are printed.

■ **USAGE T**

The time taken (in minutes and seconds) to receive the document from start to finish is printed.

■ **PGS.**

The number of pages that were received successfully is printed.

■ **RESULT**

If the documents were received successfully, "OK" is printed.

If a reception error occurred, "NG" (No Good) is printed.

If a reception error occurred, the page number in which the error occurred, and the error code number are printed.

## Confidential Fax Inbox Reception Report

This report enables you to confirm that documents were received in a Confidential Fax Inbox.

You can set whether to automatically print a Confidential Fax Inbox Reception Report. (See "Confidential Fax Inbox RX Report," on p. 12-10.)

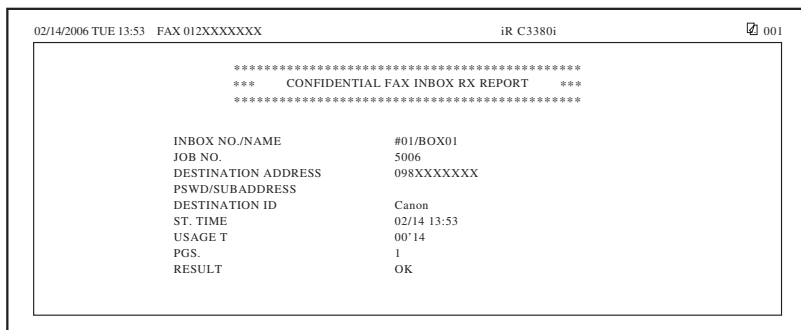

**NOTE**

This mode is available only if the optional Super G3 FAX Board or Super G3 Multi-Line Fax Board is installed.

■ **INBOX NO./NAME**

The number (00 to 49) and user assigned name of the Confidential Fax Inbox in which the documents were received is printed.

■ **JOB NO.**

The four digit number, that is automatically assigned when the document is accepted for receiving, is printed.

■ **DESTINATION ADDRESS**

The fax number of the sender is printed, up to the first 20 digits.

■ **PSWD/SUBADDRESS**

A subaddress is printed if specified. The password is not printed to maintain security.

■ **DESTINATION ID**

The name of the sender is printed.

■ **ST. TIME (Start Time)**

The date and time (in 24-hour notation) at which the document started to be received are printed.

■ **USAGE T**

The time taken (in minutes and seconds) to receive the document from start to finish is printed.

■ **PGS.**

The number of pages that were received successfully is printed.

■ **RESULT**

If the documents were received successfully, "OK" is printed.

If a reception error occurred, "NG" (No Good) is printed.

If a reception error occurred, the page number in which the error occurred, and the error code number are printed.

# Activity Report

This report is a list which enables you to check the results of all sending and receiving transactions. An Activity Report can be printed either automatically or manually.

An Activity Report is automatically printed when either the number of communication results reaches 100, or a specified time is reached. The send and receive logs can also be printed separately.

An Activity Report can be printed manually at any time from the System Monitor screen. (See "Printing the Send Job Status/Log," on p. 8-8.)

02/14/2006 TUE 15:50		IR C33801		001			
***** *** ACTIVITY REPORT TX/RX *** *****							
DEPT. ID : 511008							
ST. TIME	DESTINATION ADDRESS	DESTINATION ID	JOB NO.	MODE	PGS.	RESULT	
*02/14 12:51	172.20.56.5 /tmp/img		0104	TX	FTP	47	NG 14'10 #755
*02/14 15:03	01		0105	TX	BOX	1	OK 00'00
*02/14 15:03	starfish.organization share	Share Folder	0106	TX	FTP	0	NG 00'01 #802
*02/14 15:03	john@example.com	john	0107	TX	MAIL	1	-- 00'01
*02/14 15:03	\\swanshare	project	0108	TX	SMB	0	NG 00'04 #802
*02/14 15:04	bob@example.com	Bob	5213	RX	1-FAX	1	OK 00'01
*02/14 15:05	172.20.56.5 /tmp/img		0110	TX	FTP	1	OK 00'21
*02/14 15:05	01		0111	TX	BOX	1	NG 00'01
*02/14 15:47	starfish.organization.com share/share_dir	Share Folder	0120	TX	FTP	0	NG 00'01 #802
*02/14 15:48	012XXXXXXX	Canon U.S.A	0121	TX		0	NG 00'00 STOP

## NOTE

- A list of e-mail, I-fax, file server, and User Inbox transmissions is printed.
- If the optional Super G3 FAX Board or Super G3 Multi-Line Fax Board is installed, a list of fax transmissions in addition to the above mentioned transmissions is printed.

## ■ DEPT. ID

If Department ID Management is set, the Department ID is printed. Transmission logs are listed according to Department ID.

## ■ ST. TIME (Start Time)

The date and time (in 24-hour notation) at which the document started to be transmitted or received are printed. An asterisk (\*) indicates a job that has already been printed. If SDL or SSO is set as the login service, the user name used for login is displayed below the start time. When the machine cannot specify the user (for example, when automatically forwarding), the user name is not displayed.

## ■ DESTINATION ADDRESS

The address of the recipient is printed.

If the send job is sent to a file server (FTP, SMB, IPX, or WebDAV), the path name is printed on the second line.

If a subaddress is specified for sending a fax, the destination address is printed on the second line.

## ■ DESTINATION ID

The name of the recipient is printed.

## ■ JOB NO.

The four digit number, that is automatically assigned when the document is accepted for sending or receiving, is printed. Numbers between 0001 and 4999 are for sending, while numbers between 5001 and 9999 are for receiving.

## ■ MODE

The type and mode of transmission are printed.

Transmission type: Send (TX), Receive (RX)

Mode of transmission: FTP, SMB, IPX, WebDAV, User Inbox (BOX), I-Fax (I-FAX), E-mail (MAIL), Fax (FAX), G3

## NOTE

- FTP, SMB, IPX, WebDAV, Inbox, I-Fax, and E-mail can be displayed in the MODE column.
- If the optional Super G3 FAX Board or Super G3 Multi-Line Fax Board is installed, FAX, and G3 in addition to the above mentioned mode of transmissions can be displayed in the MODE column.

## ■ PGS.

The number of pages that were sent or received successfully is printed.

## ■ RESULT

"OK," "NG," or "- -," and the transmission time are printed.

If the documents have been received successfully by the recipient, "OK" is printed.

If a sending error occurs, "NG" (No Good) is printed, and the error code is printed on the second line.

When sending is successful, but it is not confirmed whether the e-mail message or I-fax, or the file that you sent to an imageWARE Document Manager folder, was actually delivered, "--" is printed.

 **NOTE**

If a field exceeds its display capacity, only those characters that fit in the display are printed.

## Fax Activity Report

The Fax Activity Report is a printed log that shows the results of send and receive jobs. A Fax Activity Report can be printed either automatically or manually.

A Fax Activity Report is automatically printed when either the number of communication results reaches 40, or a specified time is reached. You can set whether to automatically print an Activity Report. (See "Fax Activity Report," on p. 12-8.)

02/14/2006TUE 14:20 FAX 012XXXXXX			iR C3380i			001	
***** *** FAX ACTIVITY REPORT TX/RX *** *****							
DEPT. ID :123							
ST. TIME	DESTINATION ADDRESS	NO.	MODE	PGS.	RESULT		
*02/12 13:29	Canon CANADA	123XXXXXX	0007 TX	ECM	0	NG00'00 0 STOP	
*02/12 13:35	Canon EUROPE	011XXXXXX	0008 TX	ECM	1	OK00'24	
*02/12 13:36	Canon U.S.A	098XXXXXX	0008 TX	ECM	0	NG00'11 0 #102	
02/12 13:38	Canon U.S.A	098XXXXXX	0009 TX	ECM	0	NG00'00 0 #995	
02/12 13:40	Canon U.S.A	098XXXXXX	0010 TX	ECM	1	OK00'18	
02/12 13:52	Canon EUROPE	011XXXXXX	5005 MEMORY LOCK	ECM	1	OK00'22	
02/13 13:53	Canon FRANCE	022XXXXXX	5006 MEMORY LOCK	ECM	1	OK00'22	
02/14 11:49	Canon CANADA	123XXXXXX	0011 TX	ECM	1	OK00'24	
02/14 13:12	Canon U.S.A	098XXXXXX	0012 TX	ECM	2	OK 00'44	
02/14 13:38	Canon U.S.A	098XXXXXX	0013 TX	ECM	1	OK00'20	
02/14 15:10	Canon U.S.A	098XXXXXX	0014 TX	ECM	1	OK00'24	

 **NOTE**

This mode is available only if the optional Super G3 FAX Board or Super G3 Multi-Line Fax Board is installed.

■ **DEPT. ID**

If Department ID Management is set, the Department ID is printed. Transmission logs are listed according to the Department ID.

■ **ST. TIME (Start Time)**

The date and time (in 24-hour notation) at which the document started to transmit or receive are printed. An asterisk (\*) indicates a document that has already been printed. If SDL or SSO is set as the login service, the user name used for login is displayed below the start time. When the machine cannot specify the user (for example, when automatically forwarding), the user name is not displayed.

## ■ DESTINATION ADDRESS

The name and fax number of the remote party are printed. If a subaddress or sender's name has been specified, it is printed beneath the fax number.

## ■ NO.

The four digit number, that is automatically assigned when the document is accepted for sending or receiving, is printed. Numbers between 0001 and 4999 are for sending, while numbers between 5001 and 9999 are for receiving.

## ■ MODE

The communicated contents and the Communication mode are printed.

Sending: TX, Delayed TX, Sequential Broadcast TX, Delayed Sequential Broadcast, Transfer TX, Direct Sending

Receiving: Automatic RX, Confidential Fax Inbox RX, Memory RX, Transfer RX

Communication mode: ECM

Line Type: Line1, Line 2 (The optional Super G3 Multi-Line Fax Board is installed.)

## ■ PGS.

The number of pages that were sent or received successfully is printed.

## ■ RESULT

"OK" or "NG" and the transmission time are printed.

If the documents have been successfully sent to the recipient, "OK" is printed.

If a sending error occurred, "NG" (No Good) is printed, and the number of pages that failed to be sent and the error code are printed on the second line. If none of the pages were sent successfully, "0" is printed.



# Forwarding Conditions List

You can print the contents of the forwarding settings that have been specified. Manually print the Forwarding Conditions List whenever necessary. (See "Printing Forwarding Settings," on p. 11-42.)

02/14/2006 TUE 15:30		iR C3380i		001	
***** *** FORWARDING CONDITIONS LIST *** *****					
CONDITION NAME		FORWARD W/O CONDITIONS (I-FAX RX)			
ON/OFF		OFF			
FORWARDING DESTINATION					
FWDING DESTIN. TYPE		I-FAX			
FWDING DESTIN. NAME		Tom			
URL SEND		OFF			
SEND DOCUMENT NAME		TEST1			
FILE FORMAT		TIFF			
DIVIDE INTO PAGES		OFF			
STORE/PRINT RECEIVED DOC.		OFF			
FORWARDING DONE NOTICE		-			
NOTICE ONLY FOR ERRORS		-			
CONDITION NAME		test			
ON/OFF		OFF			
FORWARDING CONDITION					
RECEIVE TYPE		I-FAX			
TO		DISREGARDED			
FROM		EQUALS bob@example.com			
SUBJECT		DISREGARDED			
FORWARDING DESTINATION					
FWDING DESTIN. TYPE		I-FAX			
FWDING DESTIN. NAME		Tom			
URL SEND		OFF			
SEND DOCUMENT NAME		TEST2			
FILE FORMAT		TIFF			
DIVIDE INTO PAGES		OFF			
STORE/PRINT RECEIVED DOC.		OFF			
FORWARDING TIME		EVERYDAY 00:00-10:00			
FORWARDING DONE NOTICE		-			
NOTICE ONLY FOR ERRORS		-			

# Registered LDAP Server List

You can print the registered LDAP server settings. (See "Printing LDAP Server Settings," on p. 11-50.)

```
02/14/2006 TUE 15:30                                iR C3380i                                001
*****
*** REGISTERED LDAP SERVER LIST ***
*****

SERVER NAME                                           abc
SERVER ADDRESS                                       hostname.example.com
LOCATION TO START SEARCH                              "ou=ffm, o=mip"
USE SSL                                              Off
PORT NUMBER                                          389
MAX. NO. OF ADDRESSES TO SEARCH                    100
SEARCH TIMEOUT                                       60 sec.
LOGIN INFORMATION                                    USE
  USER                                              abcdefg
  DISPLAY AUTHENT. DIALOG WHEN SEARCHING            Off
  SERVER LDAP VERSION AND CHARACTER CODE            VER.3(UTF-8)

SERVER NAME                                           def
SERVER ADDRESS                                       177.22.32.64
LOCATION TO START SEARCH                              "ou=ffm, o=mip"
USE SSL                                              Off
PORT NUMBER                                          389
MAX. NO. OF ADDRESSES TO SEARCH                    200
SEARCH TIMEOUT                                       120 sec.
LOGIN INFORMATION                                    DO NOT USE
  SERVER LDAP VERSION AND CHARACTER CODE            VER.3(UTF-8)

SERVER NAME                                           ghi
SERVER ADDRESS                                       hostname.example.com
LOCATION TO START SEARCH                              "DC=mip, DC=ffm, DC=canon, DC=com"
USE SSL                                              Off
PORT NUMBER                                          389
MAX. NO. OF ADDRESSES TO SEARCH                    100
SEARCH TIMEOUT                                       180 sec.
LOGIN INFORMATION                                    USE (SECURITY AUTHENTICATION)
  USER                                              hijklm
  DOMAIN NAME                                        ffm.example.com
  DISPLAY AUTHENT. DIALOG WHEN SEARCHING            Off
  SERVER LDAP VERSION AND CHARACTER CODE            VER.3(UTF-8)
```

# Address Book List

You can print the contents of the Address Book (subaddress books 1 to 10 or one-touch buttons). Manually print the list of the selected Address Book whenever necessary. (See "Address Book List," on p. 12-11.)

02/14/2006 TUE 15:30		iR C3380i	001
***** *** ADDRESS BOOK LIST (1) *** *****			
DESTINATION NAME	CLASS	DESTINATION ADDRESS	
file share	FTP	starfish.organization.com share	
GROUP tom image server  project	GROUP I-FAX FTP BOX SMB	tom@example.com 172.20.56.5 01 \\swan\share	
bob	I-FAX	bob@example.com	
sales 4	SMB	\\swan\share \\sales_4	
nick	MAIL	nick@example.com	
Canon U.S.A	FAX	012XXXXXXX	
GROUP Canon CANADA Canon CANADA	GROUP FAX FAX BOX	. 098XXXXXXX 098XXXXXXX 01	

## NOTE

- The destinations of e-mail, I-fax, file server, and group destinations are displayed.
- If the optional Super G3 FAX Board or Super G3 Multi-Line Fax Board is installed, fax numbers in addition to the above mentioned destinations are displayed.

## ■ DESTINATION NAME

The name of the specified destination is printed.

When printing the contents of a one-touch button, the number of the one-touch button is printed on the first line.

## ■ CLASS

The specified destination's class (transmission mode) is printed.

## ■ DESTINATION ADDRESS

- If the Class is "FTP," "SMB," "IPX," or "WebDAV" (file server):  
The host name is printed on the first line, and the folder path on the second line.
- If the Class is "BOX":  
The number of the User Inbox is printed.
- If the Class is "I-FAX" or "MAIL":  
The I-fax address or e-mail address is printed.

- If the Class is "FAX":  
The fax number is printed on the first line, and the subaddress on the second line, if it is specified.
- If the Class is "GROUP":  
The destinations stored in the group address are printed on the second line and continue down in a list. If a file server is stored in the group address, no additional information is printed on the second line.

# User's Data List

The User's Data List prints out the Send Settings made in Communications Settings, Report Settings, and System Settings (from the Additional Functions screen). Manually print the User's Data List whenever necessary. (See "User's Data List," on p. 12-12.)

02/14/2006 TUE 15:30		iR C3380i	0001
***** *** USER'S DATA LIST (Communications) *** *****			
Communications Settings			
TX Settings			
Sender's Names (TTI)	01: Tokyo		
	02: New York		
	03: London		
Unit Name	Canon		
Erase Failed TX	On		
Data Compression Ratio	Normal		
Handle Documents with Forwarding Errors	Off		
Retry Times	3 times		
Display Confirmation for Favorites Button	On		
Image Level for PDF (Compet)			
Image Lvl in Text/Photo or Photo Mode	Normal		
Image Level in Text Mode	Normal		
PDF(OCR) Settings			
Smart Scan	On		
Num of Char for Doc Name Setting	24 characters		
Default Screen for Send	New Address		
TX Terminal ID	On		
Printing Position	Outside		
Display Destination Name	On		
Use Chunked Encoding with WebDAV Sending	On		
Gamma Value for YCbCr Send Jobs	1.8		
RX Settings			
2-Sided Print	Off		
Select Cassette			
Switch A	On		
Switch B	On		
Switch C	On		
Switch D	On		
Receive Reduction	On		
Receive Reduction	Auto		
Reduce %	90%		
Reduce Direction	Vertical Only		
Received Page Footer	Off		
2 ON 1 Log	Off		
Gamma Value for YCbCr Received Jobs	1.8		
Report Settings			
TX Report	For Error Only		
Report with TX Image	On		
Report with Color TX Image	Off		
Activity Report			
Auto Print	On		
Daily Activity Report Time	Off		
Send/Receive Separate	Off		
System Settings			
Communications Settings			
E-mail/I-Fax Settings			
Maximum Data Size for Sending	3 MB		
Full Mode TX Timeout	24 Hours		
Divided Data RX Timeout	24 Hours		
Default Subject	Attached Image		
Print MDN/DSN on Receipt	Off		
Always send notice for RX errors	On		
Use Send Via Server	Off		
Allow MDN Not Via Server	On		
Memory RX Inbox Settings			
Use I-Fax Memory Lock	Off		
Memory Lock Start Time	Off		
Memory Lock End Time	Off		
Restrict the Send Function]			
E-mail	Off		
I-FAX	Off		
FILE	Off		
Restrict New Address	Off		
E-mail/I-Fax Domain Sending Restriction			
Restrict Sending to Domains	Off		

\*\*\*\*\*  
 \*\*\* USER'S DATA LIST (FAX) \*\*\*  
 \*\*\*\*\*

```

COMMUNICATIONS SETTINGS
  FAX SETTINGS
    USER SETTINGS
      UNIT TELEPHONE #           012XXXXXXX
      TEL LINE TYPE               TONE
      VOLUME CONTROL
        ALARM VOLUME             4
        MONITOR VOL.             4
    TX SETTINGS
      ECM TX                       ON
      PAUSE TIME                   2 SEC
      AUTO REDIAL                  ON
      REDIAL TIMES                 2 TIMES
      REDIAL INTERVAL             2 MIN
      TX ERROR RESEND             ERROR & 1ST PAGE
      CHECK DIAL TONE BEFORE SENDING ON
      TX TERMINAL ID              ON
      TTI IN/OUT SIDE OF IMAGE    OUTSIDE
      DISPLAY DESTINATION NAME    ON
      TELEPHONE # MARK            FAX
    RX SETTINGS
      ECM RX                       ON

REPORT SETTINGS
  FAX
    FAX TX REPORT                 FOR ERROR ONLY
    REPORT WITH TX IMAGE         ON
    FAX ACTIVITY REPORT
      AUTO PRINT                  ON
      TX/RX SEPARATE             OFF
      DAILY ACTIVITY REPORT TIME  OFF
    FAX RX REPORT                OFF
    CONF. FAX INBOX RX REPORT    ON

SYSTEM SETTINGS
  COMMUNICATIONS SETTINGS
    FAX SETTINGS
      TX START SPEED              33600bps
      RX START SPEED              33600bps
      PIN CODE ACCESS             OFF
    MEMORY RX INBOX SETTINGS
      USE FAX MEMORY LOCK        OFF
      MEMORY LOCK START TIME     OFF
      MEMORY LOCK END TIME       OFF
  RESTRICT THE SEND FUNCTION
    RESTRICT NEW ADDRESSES       OFF
      FAX                         OFF
    ALLOW FAX DRIVER TX          ON
    CONFIRM ENTERED FAX NUMBERS  OFF
  
```

# Specifications

Specifications are subject to change without notice for product improvement or future release.

## Universal Color Send

### ■ Scan Features

Item	Specifications
Communication Protocol	FTP (TCP/IP), SMB (TCP/IP), NCP (IPX), WebDAV
Data Format	TIFF, JPEG, PDF
Resolution	100 x 100 dpi, 150 x 150 dpi, 200 x 100 dpi, 200 x 200 dpi, 200 x 400 dpi, 300 x 300 dpi, 400 x 400 dpi, 600 x 600 dpi
System Environment	Windows 98/Me/XP, Windows 2000 Server/Professional (SP1 or later), Windows Server 2003, Novell Netware 3.2/4.11/4.2/5/5.1, Solaris Version 2.6 or later, Mac OS X or later, Red Hat Linux 7.2, Windows XP Professional, Red Hat Enterprise Linux AS/ES/WA 4.0 or later
Interface	100BASE-TX, 10BASE-T
Color Mode	Automatic-Color Select (Full Color/Grayscale), Automatic-Color Select (Full Color/Black-and-White), Full Color, Grayscale, Black-and-White
Original Type	Text, Text/Photo, Photo
Others	Preview, Browse Windows (SMB) File Server, Browse NetWare (NCP) File Server
Optional PDF Functions	Compact, Trace and Smooth, Encryption, OCR, Digital Signing (Device Signature, User Signature)

## ■ E-mail and I-Fax Features

Item	Specifications	
Communication Protocol	SMTP, POP3, I-Fax (Simple, Full)	
Resolution	For Sending E-mail	
	For Sending I-Fax	Black-and-White
		Color
Format	E-mail	
	I-Fax	Black-and-White
		Color
Original Size	E-mail	
	I-Fax	
Server Software	Microsoft Exchange Server 5.5 (SP1 or later), Sendmail 8.93, Lotus Domino R 4.6 or later	
Other	Searches a destination via the LDAP Server, Preview	
Optional PDF Functions (E-mail only)	Compact, Trace and Smooth, Encryption, OCR, Digital Signing (Device Signature, User Signature)	

\*1 Available only if [A3/11x17] is selected on the Destination Conditions screen. (See "Specifying an I-Fax Address," on p. 2-7, "I-Fax Addresses," on p. 10-12, or "Storing/Editing One-Touch Buttons," on p. 10-35.)

\*2 Available only if [Receive in Color] is set to 'On' on the Destination Conditions screen according to the specifications of the recipient's machine. (See "Specifying an I-Fax Address," on p. 2-7, "I-Fax Addresses," on p. 10-12, or "Storing/Editing One-Touch Buttons," on p. 10-35.)

\*3 Sent as LTR



## Super G3 FAX Board

Item	Specifications
Telephone Line Used/Number of Lines	Public Switched Telephone Network, Facsimile network 1 line
Scan line Density (Scan, Transmission)	Standard: 8 pels <sup>*1</sup> /mm x 3.85 line/mm Fine: 8 pels <sup>*1</sup> /mm x 7.7 line/mm Super-Fine: 8 pels <sup>*1</sup> /mm x 15.4 line/mm Ultra-Fine: 16 pels <sup>*1</sup> /mm x 15.4 line/mm
Transmission Speed	Super G3: 33.6 kbps, G3: 14.4 kbps
Compression Method	MH, MR, MMR, JBIG
Transmission Type	Super G3, G3
Sending Original Sizes	11" x 17" to STMT
Receiving Paper Sizes	11" x 17" to STMT
Transmission Times	ECM-MMR: Approximately 3.2 seconds G3MR method: Approximately 13 seconds G3MH method: Approximately 13 seconds JBIG: Approximately 2.6 seconds
Auto Dial Function	Address Book: 1,800 destinations (including destinations stored in one-touch buttons)
Image Memory	Approximately 6,000 pages

\*1 Pels stands for picture elements (pixels).

# Super G3 Multi-Line Fax Board

Item	Specifications
Telephone Line Used/Number of Lines	Public Switched Telephone Network, Facsimile network 2 lines
Scan line Density (Scan, Transmission)	Standard: 8 pels <sup>*1</sup> /mm x 3.85 line/mm Fine: 8 pels <sup>*1</sup> /mm x 7.7 line/mm Super-Fine: 8 pels <sup>*1</sup> /mm x 15.4 line/mm Ultra-Fine: 16 pels <sup>*1</sup> /mm x 15.4 line/mm
Transmission Speed	Super G3: 33.6 kbps, G3: 14.4 kbps
Compression Method	MH, MR, MMR, JBIG
Transmission Type	Super G3, G3
Sending Original Sizes	11" x 17" to STMT
Receiving Paper Sizes	11" x 17" to STMT
Transmission Times	ECM-MMR: Approximately 3.2 seconds G3MR method: Approximately 13 seconds G3MH method: Approximately 13 seconds JBIG: Approximately 2.6 seconds
Auto Dial Function	Address Book: 1,800 destinations (including destinations stored in one-touch buttons)
Image Memory	Approximately 6,000 pages

\*1 Pels stands for picture elements (pixels).

## A

### Activity Report

A record listing all documents that have been sent and received.

### ADF

Automatic Document Feeder. Originals placed in the feeder are automatically fed sheet by sheet to the platen glass for scanning. The feeder also automatically turns over two-sided originals to make one- or two-sided prints.

### ASCII code

ASCII (American Standard Code for Information Interchange) is a set of standardized codes used to represent letters, numbers, punctuation marks, a few symbols, and control characters. A seven digit (or seven bit) binary number can represent one of 128 distinct codes.

### Authentication

A system process which validates a user's login information. The user's name and password must be registered in the system beforehand, and if the system detects a match, access is granted, depending on the user's access rights and permissions.

### Auto Redial

When Auto Redial is set to 'On', the machine automatically redials the recipient's facsimile number if the line is busy, or if there is a sending error. The machine will wait two minutes (default) after the initial attempt before redialing. You can specify the number of times that the machine redials, the length of the redial interval, and whether to redial after a transmission error.

## B

### BOOTP

BOOTstrap Protocol. A protocol that enables a client machine to automatically obtain network setup information from a server over a TCP/IP network. BOOTP enables a client to automatically locate such information as the host name, domain name, and IP address, so that it is not necessary to enter these items manually.

### bps

Bits per second. The measure of transmission speed used in relationship to networks and communication lines.

## C

### **CCITT/ITU-T**

A committee that sets international standards for telecommunications. CCITT/ITU-T was formerly known as CCITT (Consultative Committee for International Telegraph and Telephone), but is now succeeded by ITU-T (International Telecommunications Union-Telecommunications Sector).

### **CMYK**

Cyan (C), Magenta (M), Yellow (Y), and Black (K). CMYK is the standard color model used for offset printing of full-color documents, using the secondary colors of light (plus black). CMYK is a subtractive process, which subtracts reflected colors from white. The CMY color model uses cyan, magenta, and yellow to create colors throughout the spectrum. The combination of cyan, magenta, and yellow in equal amounts results in no reflection of light (black). One of the most difficult aspects of color printing is color matching, which is properly converting RGB color into CMYK colors, so that what gets printed looks the same as what appears on the display. The four colors are printed on paper as layers of halftone dots in varying sizes and angles to create the illusion of different colors.

### **Confidential Fax Inbox**

A type of inbox for storing received fax/I-fax documents. If received fax/I-fax documents match the forwarding conditions, they are forwarded to the Confidential Fax Inbox corresponding to the forwarding conditions, without being printed. The documents can then be printed whenever necessary. If a password is set for a Confidential Fax Inbox, it is necessary to enter a password to print the documents.

### **Copy Ratio/Zoom Ratio**

Numeric representation for the reduction or enlargement of an original.

## D

### **Delayed Transmission**

Also called "Delayed TX." You can set a time for a document to be sent, and you do not have to be present when the document is sent at the specified time. You can reserve up to 120 delayed transmissions.

### **Device Information Delivery**

Registering device information in your machine enables you to set the machine to deliver the same device information to other imageRUNNER machine models that are connected to the same network. This enables you to easily manage multiple machines at the same time.

## **Device signature certificate**

The device signature certificate, when used with a private key inside the machine, enables you to add a digital signature to a scanned document. This enables the recipient to verify which machine scanned the document.

## **DHCP**

Dynamic Host Configuration Protocol. A protocol which automatically specifies the network settings of a client on a TCP/IP network. Many of the settings required to set up TCP/IP, which is the standard protocol of the Internet, can be made automatically using DHCP.

## **Digital signature**

A code that can be attached to an electronically transmitted message, which uniquely identifies the sender.

## **Direct Sending**

Use Direct Sending when the memory is full, and you still need to send a document. Direct Sending scans and sends one page at a time without storing the document in memory. This enables you to send a document even when the memory is full.

## **DNS server**

Domain Name System server. A server which maintains a database that translates the domain names of Internet servers, such as www.w3.org, into Internet Protocol (IP) addresses, such as "18.176.0.26". This enables clients to connect to a server with a host name rather than a numeric IP address.

## **Domain**

A management concept that divides large scale networks into groups for identifying individual computers and users. The Internet is managed by classifying domains according to geographical location or type (business, organization, educational institution, etc.).

## **dpi**

Dots Per Inch. A measure of screen and printer resolution that is expressed as the number of dots that a device can print or display per linear inch.

## E

### ECM

Error Correction Mode. Reduces system and line errors when sending or receiving from another fax machine with ECM capability. ECM divides a page into blocks and inspects each block for data lost through poor transmission. If part of the data is missing in a certain block, ECM retransmits that data from the beginning of the block until it confirms that all of the data within the block has been transmitted successfully. In this way, ECM guarantees that a good image can be received at the receiving end. ECM is very effective where the telephone lines are in poor condition. However, ECM slows the transmission speed, and you may turn this mode off, if it is not needed.

### Error indicator

The Error indicator blinks a red light when a paper jam occurs or the machine has run out of toner or paper. When the Error indicator maintains a steady red light, contact your local authorized Canon dealer.

### Ethernet

An industry standard LAN (Local Area Network) system for connecting multiple computers. Data is sent from one computer to another by dividing it into packets, and the packets reach their destinations smoothly without any collision with other packets.

## F

### File formats

File formats are used to save image data. This machine supports six different file formats: TIFF, JPEG, PDF, PDF (Compact), PDF (OCR), and PDF (Trace).

### File server

A personal computer or workstation to which two or more users on client personal computers can gain access via a LAN (Local Area Network), to share and use its hard disk drive.

### Fine

A resolution mode for sending originals at twice the detail of the Standard resolution mode.

### Forwarding

The process of sending a received fax/I-fax document to another destination. For example, if your machine at work receives a document, you can have the machine forward the document to a machine at your home. This machine can also forward documents to a Confidential Fax Inbox.

## **FTP**

File Transfer Protocol. A client-server protocol enabling a user to transfer files on one computer to and from another computer over a TCP/IP network. The File Transfer Protocol also governs the client program with which the user transfers files.

## **I**

### **I-fax**

I-fax (Internet fax) enables you to send and receive a scanned original converted to TIFF (Tagged Image File Format) or PDF (Portable Document Format) image data as an e-mail attachment to/from any I-fax compatible facsimile or personal computer with Internet e-mail functionality.

### **imageWARE**

Canon imageWARE is a software suite for business environments that provides functions to efficiently capture, create, manage, and distribute documents. The imageWARE suite also supports on-demand printing and publishing.

For more information, please see the imageWARE Web site at <http://www.imageware.com>.

### **imageWARE Document Manager Gateway**

Software for sending scanned documents from Color imageRUNNER machines equipped with the Send function, to imageWARE Document Manager folders via the network. imageWARE Document Manager Gateway is a standard feature of both the Workgroup Edition and the Enterprise Edition of imageWARE Document Manager. It consists of two programs: imageWARE Document Manager Gateway Server, which stores the documents, and imageWARE Document Manager Gateway Administrator, which makes the settings for document storage destinations.

### **Internet Protocol (IP)**

The underlying set of networking rules that describes how data is transmitted across the Internet. Internet Protocol enables data from one computer to be split into packets, and sent to another computer with a specific IP address.

### **IP address**

Internet Protocol address. A 32-bit numeric address used by IP (Internet Protocol) to specify a computer or device on the Internet. The IP address is usually written as four numbers delimited by periods. For example, 128.121.4.5.

### **ITU-T**

See CCITT/ITU-T.

## **J**

### **JBIG**

Joint Bi-level Image Experts Group. An experts group file specification that defines a standard for compressing (reducing the size of) image files without any loss in image information. Files containing photographic images in Web pages are generally compressed so they can be transferred across the Internet more quickly. JPEG, the format currently used, causes some loss in image data after compression, and so reduces image quality. JBIG compression overcomes this shortcoming.

### **JPEG**

Joint Photographic Experts Group. An experts group file specification that defines a standard for compressing (reducing the size of) photographic and photorealistic image files. The image compression method used involves some loss of information, and so reduces image quality. Files containing photographic images in Web pages are generally compressed by using the JPEG format so they can be transferred across the Internet more quickly.

## **L**

### **LAN**

Local Area Network. A network system formed by linking a server, workstations, devices, and computers, which are all located in the same building or some other relatively limited area.

### **LDAP**

Lightweight Directory Access Protocol. A network protocol that enables you to locate organizations, individuals, and other resources, such as files and printers on a network, whether on the public Internet or on a corporate intranet.

### **Log on**

Entering a user name and password as a means of user authentication to start a computer session or gain access to a service.

### **Long distance dialing**

When dialing or registering long distance numbers, you may need to insert a pause within or after the telephone number. The destination and length of the pause differ depending on the system. Contact your local authorized Canon dealer or local telephone company if you experience difficulty in long distance dialing.



# M

## MEAP

Multifunctional Embedded Application Platform. A system enabling the installation of the Java platform and Java applications on your machine. Utilization of MEAP also enables you to install and uninstall MEAP applications.

## Memory Lock

Usually a document is printed as soon as it is received; but with Memory Lock, all documents received are stored in memory until you enter a password to print them. This enables you to attend to the documents at your own leisure, and prevents printed documents from piling up in the output tray.

## Memory RX Inbox

The Memory RX (Receive) Inbox is an inbox for storing received fax/I-fax documents. Received documents are stored in the Memory RX Inbox without being printed. You can print or send the stored documents later, or whenever necessary.

## Memory Sending

Memory Sending scans documents into memory before sending them. You can retrieve your original once scanning is complete, and you do not have to wait until sending is complete.

# N

## NetBEUI

NetBIOS Enhanced User Interface. NetBEUI is a network protocol originally designed by IBM, and later extended by Microsoft and Novell. In a small network, NetBEUI is more efficient than other protocols, such as TCP/IP. It is supported natively by IBM operating systems and Microsoft Windows to provide services, such as file sharing and printing.

## NetBIOS

Network Basic Input Output System. A program that enables applications on different computers to communicate within a LAN (Local Area Network). NetBIOS is used in Ethernet and Windows 2000/XP networks.

## NetSpot

Network management software that enables the setup and management of multiple printers connected to a network from one central location. A network manager can monitor conditions of network printers, ascertain online/offline status, error status, the amount of paper in cassettes, verify information on mounted fonts, and other readings. All of the functions that are conventionally conducted through the operation panel of the respective machines can be performed from one location.

## **NetWare**

Novell NetWare. Novell's client-server network operating system for the IBM PC. NetWare uses the IPX/SPX, NetBEUI, or TCP/IP network protocol. NetWare supports MS-DOS, Microsoft Windows, OS/2, and Macintosh clients. NetWare for UNIX gives users access to UNIX hosts.

## **O**

### **OS/2**

A family of multitasking operating systems developed by IBM for Intel x86-based computers. OS/2 provides a graphical user interface similar to Windows, as well as a command line interface similar to DOS. Add-ons to OS/2 enable it to run DOS and Windows applications.

## **P**

### **Pause**

You can insert a pause within a telephone number or at the end of a telephone number. A pause is also sometimes required to connect to an outside line, or for overseas fax transmissions to certain countries.

### **Pause Time**

The default settings are two seconds if a pause is inserted within the telephone number (may vary depending on your location), and 10 seconds if a pause is added to the end of the telephone number. Only the length of pauses inside a telephone number, and not those at the end, can be changed.

### **PBX**

Private Branch eXchange. An in-house telephone switching system that interconnects telephone extensions to each other, as well as to the external telephone network. A PBX controls the flow of telephone traffic through instruments, such as paging systems, and automatic callback and dialing.

### **PDF**

Portable Document Format. The page description language used in Adobe Systems' Acrobat document exchange system, which is restricted neither by device nor resolution. PDF displays documents in a way that is independent of the original application software, hardware, and operating system used to create those documents. A PDF document can contain any combination of text, graphics, and images.

**PDF (Compact)**

One of the file formats available in this machine. The text and image portions of an original are processed separately to achieve a high level of compression without compromising the quality of the text. The resulting file or data size is smaller than that achieved by conventional PDF, and is therefore recommended for jobs that are to be sent over the network.

**PDF (OCR)**

A file format that performs OCR (Optical Character Recognition) processing on a scanned document. This process extracts any recognizable text data, and adds it as a transparent layer to create a PDF with searchable text. You can search the text using Adobe Acrobat/Adobe Acrobat Reader, or your operating system's search function.

**PDF (Trace)**

A file format that converts the text and the line drawing portions of an original to scalable outline data. The outline data (Trace) can be extracted and used in Adobe Illustrator. The smoothing process can also be applied to the text of the outline data, so it has less of a jagged edge when seen on a PC monitor or in print.

**PIN Code**

Personal Identification Number Code. To prevent unauthorized access to telephone lines, some PBX (Private Branch eXchange) systems require that a PIN code be entered when making a call or sending a document. Depending on the PBX system, the PIN code may be entered before the number as a prefix, or after the number as a suffix. If your PBX needs a PIN code to connect to an outside line, you can specify the user data settings of the machine so that it prompts you for a PIN code every time you dial.

**Processing/Data indicator**

The Processing/Data indicator flashes a green light when the machine is performing operations, and maintains a steady green light when documents are stored in memory.

**Protocol**

A set of rules that govern the transmission of data across a network. Examples of protocols are FTP, DHCP, BOOTP, RARP, IPP, TCP/IP, and LDAP.

# R

## Resolution

The density of dots attained by a device, such as a fax, scanner, or printer, in producing an image. Expressed in terms of dots per inch (dpi). Low resolution causes font characters and graphics to have a jagged appearance. Higher resolution means smoother curves and angles, as well as a better match to traditional typeface designs. Resolution values are represented by horizontal data and vertical data (e.g., 600 x 600 dpi).

## RGB

Red (R), Green (G), and Blue (B) are the three primary colors of light. RGB is the standard color model used in computer/television monitors, scanners, and digital cameras. RGB is an additive system (colors are added to a black background), typically produced by emitted light. The RGB color model blends varying intensities of red, green, and blue light to create colors throughout the spectrum. A combination of these colors in equal amounts produces white.

## Rotary Pulse

Also called "pulse dial." On a rotary pulse telephone, a dial is turned to send pulses to the telephone switching system.

## RX

Abbreviation for "Reception/Receiving."

## RX Password

The RX Password is needed to send or receive documents to and from a fax machine that uses ITU-T standard subaddresses and passwords. If the passwords on both ends do not match, the fax is not transmitted. Numbers of up to 20 digits, including spaces, asterisks (\*), and pound signs (#), can be used for the RX Password.

# S

## Scanning Area

The area actually scanned is slightly smaller than the size of the original document. Therefore, words or images near the edges of the document may not be scanned. As a result, make sure that there is some margin space on all sides of the document you are sending.

## Sender's Name

Your personal or organization's name. The sender's name, fax number, date, and time are printed on each page you send to the recipient. You can register up to 99 sender names.

## **Sequential Broadcast**

Sequential Broadcasting enables you to send a scanned document to up to 256 destinations simultaneously. If you frequently send documents to the same destinations, it is highly recommended that you register the numbers as a group in a one-touch button for group dialing.

## **SMB**

Server Message Block. A protocol that provides file and printer sharing over a network for Windows computers.

## **SMB server**

Server Message Block server. A server running the SMB protocol.

## **SMTP**

Simple Mail Transfer Protocol. A TCP/IP protocol for sending messages from one computer to another on a network.

## **SSL**

Secure Sockets Layer. A protocol that ensures security and privacy when transmitting private documents over the Internet.

## **SSL encryption**

SSL uses two keys to encrypt data: a public key, which is known to "everyone," and a private or secret key, which is known only to the recipient of the message.

## **Stamp**

Applies a stamp (about 1/8" (3 mm) in diameter) on the front side of originals after they have been scanned, so that you can distinguish already scanned originals from others.

## **Standard**

Use this setting to send normal, typewritten, or printed documents containing only text and no drawings, photographs, or illustrations. See Fine, Super Fine, and Ultra Fine.

## **Startup time**

If the machine is connected to a switching hub, it may not be able to connect to a network when it is powering ON. This occurs because the spanning tree process, performed between switching hubs, prevents them from communicating with each other immediately after the machine connects to the network. A delay in the startup time is necessary for the machine to connect to the network properly.

## **Subaddress**

Subaddress is the global telecommunications standard specified by the ITU-T (International Telecommunication Union-Telecommunication Standardization Sector). When the remote party's machine supports the same standard, confidential or relayed communications are possible by attaching a subaddress and a password in advance.

## **Subaddress Books**

The main Address Book is subdivided into 10 smaller address books, which are considered subaddress books.

## **Super Fine**

A resolution mode for sending originals at four times the detail of the Standard resolution mode. If the receiving machine does not support this mode, the document is automatically sent in the Fine mode.

## **Super G3**

Super G3 is a phrase used to describe the generation of fax machines that use ITU-T V.34 standard 33.6 Kbps modems. Super G3 high-speed fax machines allow a transmission time of approximately three seconds per page, which results in reduced telephone line charges.

# **T**

## **TCP/IP**

Transmission Control Protocol/Internet Protocol. The protocol used to connect to the Internet and wide area networks.

## **Telephone Line Type**

Depending on the type of phone line that you have, set the machine to touch tone (T) or pulse (P) dialing.

## **TIFF**

Tagged Image File Format. A file format that saves images as high-density bitmaps, and is suitable for large amounts of image data. The information field (tag) at the start of each image data record indicates the type of data represented.

## **Tone**

Some data services may require that you use tone dialing. If you have a pulse dial telephone, press [Tone] to switch temporarily from pulse to tone dialing when connecting to these data services.

## **Transmission Time**

A fax transmission consists of three stages: the machine that sends the fax connects with the machine receiving it; the fax is then transmitted, after which the sender and the recipient exchange signals to confirm the end of transmission. The transmission time described in this guide is not the total time required for the entire send/receive transaction, but only the time it takes for the machine to transmit the fax document.

## **TTI**

Transmit Terminal Identification. Also called the TX Terminal ID. The TTI is the name of a person or an organization and the facsimile number of the machine that sends a document. In addition to the unit name that you register for the machine, you can create up to 99 sender names that can be used in place of the unit's name when you send a fax document.

## **TX**

Abbreviation for "Transmission/Sending."

## **U**

### **UFR II**

Ultra Fast Rendering II. A printing algorithm for realizing high-speed rendering. UFR II enables processing tasks to be executed and divided appropriately between the host PC and the printer to greatly reduce overall printing time.

### **Ultra Fine**

A resolution mode for sending originals at 16 dots/mm x 15.4 lines/mm (eight times the standard resolution). If the receiving fax machine does not support this mode, the original is automatically sent in the Super Fine or Fine mode.

### **User signature**

Adds a digital signature to a private document, based on the registered user information when logging on using a login service. This prevents unauthorized access and alterations to the signed document.

## **W**

### **WebDAV**

Web-based Distributed Authoring and Versioning. Enables users to collaboratively edit and manage files on remote Web servers. WebDAV features XML data locking properties, which prevents authors from overwriting each other's changes.

### **WebDAV server**

Web-based Distributed Authoring and Versioning server. Storing files and folders on a WebDAV server enables users to share them over the Internet.

# Y

## YCbCr

YCbCr is a color space used in video systems. Y is the luminance component, and Cb and Cr the chrominance components. YCbCr was defined in the ITU-601 (formerly CCIR-602) standard for use with digital component video.



## Numerics

- 2 On 1 Log, 9-40
- 2-Page separation, 4-4
- 2-Sided Original, 3-4
- 2-Sided Print, 9-34

## A

- Abbreviations used in this manual, xv
- Access Number Management, 11-16
- Activity Report, 12-5, 14-11, 14-25
- Address Book
  - About the Address Book, 10-2
  - Access Number Management, 11-16
  - Address Book List sample, 14-17
  - Address Book password, 11-15
  - Editing addresses, 10-30
  - Erasing addresses, 10-33
  - Naming the Address Book, 10-34
  - Printing the Address Book, 12-11
  - Storing new addresses, 10-5
- Address Book Settings table, 10-2
- Additional Functions, 9-3
- Additional Line
  - Registering fax number, 9-49
  - Registering unit's name, 9-50
  - Selecting line, 9-52
  - Selecting telephone line type, 9-51
- ADF (Automatic Document Feeder), 14-25
- Allow fax driver TX, 11-17
- Allow PDF Send with Expired Certificates, 11-20
- Always Add PDF Device Signature to Send PDF, 11-21

- ASCII code, 14-25
- Auto Redial, 9-45, 14-25
- Automatic document deletion, 9-10

## B

- Before using this machine
  - Registering the machine's fax number, 1-16
  - Registering sender names, 1-17
  - Registering the Sending Record, 1-12
  - Registering the unit's name, 1-18
  - Selecting the type of telephone line, 1-14
  - Setting the date and time, 1-14
  - Setting the display language, 1-13
  - Setting the telephone line type, 1-11
  - Things to do, 1-11
- Binding Erase, 4-5, 4-9
- Book Frame Erase, 4-5, 4-7
- bps, 14-25

## C

- Canceling jobs
  - Using the Stop key, 1-36
  - Using the System Monitor screen, 1-36
  - Using the touch panel display, 1-35
- Cc and Bcc addresses, setting, 2-32
- CCITT/ITU-T, 14-26
- CMYK, 14-26
- Color modes
  - Automatic color selection (Full Color/Black-and-White), 3-22

- Automatic color selection (Full Color/ Grayscale), 3-21
- Black-and-white, 3-22
- Changing, 3-21
- Full color, 3-22
- Grayscale, 3-22
- Communications Settings table, 9-6
- Compact PDF, sending, 5-25
- Confidential Fax Inbox , 14-26
- Confidential Fax Inbox Reception Report sample, 14-9
- Contrast
  - Adjusting, 4-13
  - High, 4-13
  - Low, 4-13
- Copy Ratio/Zoom Ratio, 14-26
- Copyrights, xxiii
- Digital Signature, 5-34
  - Device Signature, 5-34, 5-35
  - User Signature, 5-34, 5-36
- Direct Sending, 5-3, 14-27
- Disclaimers, xxiv
- Displaying Confirmation for Favorites Buttons, 9-20
- Display language, setting, 1-13
- Displays used in this manual, xiv
- Divided RX Timeout, 11-4
- DNS server, 14-27
- Document size
  - About document sizes, 3-8
  - Registering, 3-11
  - Specifying, 3-8
- Domain, 14-27
- dpi, 14-27

## D

- Date and time, setting, 1-14
- Data Compression Ratio, 9-11
- Default Send screen, 9-27
- Delayed transmission, 14-26
- Destinations, checking/changing, 2-34
- Destinations, erasing
  - From the Address Book, 10-33
  - From the destination list, 2-36
- Destinations, specifying Using New Address Tab
  - Fax number, 2-2
  - E-mail address, 2-6
  - File server address, 2-11
  - I-fax address, 2-7
  - Sending to yourself, 2-22
  - User Inbox, 2-20
- Device Signature Certificate, confirming, 9-25
- DHCP, 14-27
- Dial Tone, checking, 9-47
- Different Size Originals, 3-6

## E

- ECM, 1-3, 9-43, 9-48, 14-28
- E-mail/I-fax domain sending restriction, 11-19
- E-mail/I-Fax settings
  - Always send notice for RX errors, 11-5
  - Default Subject, 11-5
  - Divided Data RX Timeout, 11-4
  - Full Mode TX Timeout, 11-4
  - Maximum Data Size for Sending, 11-4
  - Print MDN/DSN on Receipt, 11-5
  - Use Send Via Server, 11-5
- Encrypted PDF, sending, 5-29
- Enlargement, 3-17
- Entered fax numbers, confirming, 11-18
- Error Indicator, 14-28
- Error messages, 13-9
- Error code list, 13-14
- Ethernet, 14-28

## F

### Favorites Buttons

- About the Favorites Buttons, 9-16
- Displaying confirmation, 9-20
- Erasing, 9-19
- Naming, 9-17
- Registering, 9-16
- Registering a Comment, 9-18
- Specifying, 2-26

### Fax Activity Report sample, 14-13

### Fax information services, 7-8

### Fax jobs

- Available paper sizes, 6-10
- Checking fax job details, 8-9
- Checking/Changing the status of fax jobs, 8-9
- Printing the Fax Activity Report, 8-11
- Use Fax Memory Lock, 11-10

### Fax number, registering, 1-16

### Fax RX Report sample, 14-8

### Fax settings

- Adjusting the alarm and monitor volume, 9-42
- Auto Redial, 9-45, 14-25
- ECM reception, 9-48
- ECM transmission, 9-43
- Pause Time, 9-44
- Reception password, 11-7
- Send/Receive start speed, 11-7

### Fax TX Report/Fax Error TX Report sample, 14-5

### FCC (Federal Communications Commission), xvi

### File Format, setting

- About file format, 5-21

### File formats, 14-28

### File server, 14-28

### Fine, 14-23, 14-28

### Flow of sending operations, 1-20

### Footer information, printing, 9-39

### Forwarding, 14-28

### Forwarding Conditions List sample, 14-15

### Forwarding errors, handling, 9-12

### Forwarding settings

- About forwarding settings, 11-22
- Checking/Changing, 11-40
- Erasing, 11-41
- Forwarding without conditions, 11-35
- Printing, 11-42
- Storing, 11-23
- Turning the forwarding function On/Off, 11-41

### Frame Erase

- About Frame Erase, 4-5
- Binding Erase, 4-5, 4-9
- Book Frame Erase, 4-5, 4-7
- Original Frame Erase, 4-5, 4-6

### FTP, 14-29

## G

### Gamma value, setting, 9-32, 9-41

### Glossary, 14-25

## I

### I-fax, 14-29

### I-fax jobs

- Available paper size, 6-10
- Checking the arrival of an I-fax, 8-13
- Use I-fax Memory Lock, 11-11

### I-fax settings, 11-4

### Illustrations used in this manual, xv

### Image Quality Adjustment

- About Image Quality Adjustment, 4-14
- Prevent Bleeding, 4-14, 4-16
- Remove Background, 4-14

### imageWARE, 14-29

### imageWARE Document Manager Gateway, 14-29

Important Safety Instructions, xxv  
Internet Protocol (IP), 14-29  
IP address, 14-29  
ITU-T, 1-3, 14-29

## J

JBIG, 14-30  
Job Build, 4-10  
Job Done Notice, 5-16  
Job Recall, 5-38  
JPEG, 5-23, 14-30

## K

Keys used in this manual, xiv

## L

LAN, 14-30  
LDAP, 14-30  
LDAP server settings  
    About LDAP server settings, 11-43  
    Changing the LDAP server settings, 11-48  
    Deleting an LDAP server, 11-48  
    Printing the LDAP server settings, 11-50  
    Registered LDAP server list, 14-16  
    Registering an LDAP server, 11-43  
Legal notices  
    Copyrights, xxiii  
    Disclaimers, xxiv  
    FCC (Federal Communications Commission),  
        xvi  
    Super G3, xxii  
    Trademarks, xxiii  
Line type, setting, 1-11  
Log on, 14-30  
Long distance, 10-8, 14-30

## M

MEAP, 14-31  
Memory lock, 14-31  
Memory RX Inbox, 14-31  
Memory RX Inbox settings  
    About Memory RX Inbox settings, 11-9  
    Memory Lock End Time, 11-13  
    Memory Lock Start Time, 11-11  
    Setting the password, 11-9  
    Settings for storing received faxes in memory,  
        11-10  
    Settings for storing received I-fax documents in  
        memory, 11-11  
Memory Sending, 5-3, 14-31  
Multiple Communication Result Report sample,  
    14-6

## N

NetBEUI, 14-31  
NetBIOS, 14-31  
NetSpot, 14-31  
NetWare, 14-32  
New addresses, storing  
    Addresses obtained via a server, 10-23  
    E-mail addresses, 10-9  
    Fax numbers, 10-5  
    File server addresses, 10-17  
    Group Addresses, 10-19  
    I-fax addresses, 10-12  
    Using the Register key, 2-37

## O

One-touch Buttons  
    Erasing, 10-39  
    Storing/Editing, 10-35

- Specifying, 2-25
- Original Frame Erase, 4-5, 4-6
- Original type
  - Photo mode, 3-14
  - Text mode, 3-15
  - Text/Photo mode, 3-14
- OS/2, 14-32
- Overview, 1-6

## P

- Paper drawer selection, 9-35
- Paper sizes, 6-10
- Pause, 2-3, 14-32
- Pause Time, 9-44, 14-32
- PBX, 7-5, 14-32
- PDF, 14-32
- PDF (Compact), 14-33
- PDF (OCR), 9-23, 14-33
- PDF Compression Priority, 9-21
- Photo mode, 3-14
- PIN code, 7-5, 14-33
- Prevent Bleeding, 4-16
- Previewing, 5-17
- Processing/Data indicator, 14-33
- Protocol, 14-33

## Q

- Q&A, 13-37

## R

- Receive jobs
  - Checking receive job details, 8-12
  - Checking the arrival of an I-fax, 8-13
  - Checking the status of forwarded jobs, 8-14

- Checking/Changing the status of receive and forwarded jobs, 8-12
- Checking/Changing the status of receive jobs, 8-12
- Printing the receive job log, 8-13
- Receiving documents
  - 2 on 1 log, 9-40
  - About receiving documents, 6-3
  - Erasing received documents, 6-8
  - Forwarding received documents, 6-7
  - Printing footer information, 9-39
  - Reducing received documents, 9-37
  - Setting the Memory Lock mode, 6-7
- Reduction, 3-17
- Register key, 2-37
- Registered destinations, specifying, 2-23
  - Using the Address Book, 2-23
  - Using the Favorites Buttons, 2-26
  - Using the One-touch Buttons, 2-25
  - Using a server, 2-27
- Remove Background, 4-14
- Report settings
  - Activity Report, 12-5
  - Confidential Fax Inbox RX Report, 12-10
  - Fax Activity Report, 12-8
  - Fax RX Report, 12-9
  - Fax TX Report, 12-7
  - Send TX Report, 12-4
  - Specifying, 12-4
- Report Settings table, 12-2
- Resolution, 3-12, 14-34
- Restricting Send Function, 11-15
- Restricting entering of new addresses, 11-16
- Retry Times, 9-13
- RGB, 14-34
- Rotary pulse, 1-11, 14-34
- RX, 14-34
- RX password, 14-34

# S

## Samples

- Activity Report, 14-11
- Address Book List, 14-17
- Confidential Fax Inbox Reception Report, 14-9
- Fax Activity Report, 14-13
- Fax RX Report, 14-8
- Fax TX Report/Fax Error TX Report, 14-5
- Forwarding Conditions List, 14-15
- Multiple Communication Result Report, 14-6
- Registered LDAP Server List, 14-16
- Send Job List, 14-2
- Send TX Report, 14-3
- User's Data List, 14-19

## Scan exposure

- Automatic exposure adjustment, 3-16
- Manual exposure adjustment, 3-13

## Scan mode, selecting, 3-2

## Scan settings

- Document size, 3-8
- Erasing, 4-20
- Original type, 3-13
- Resolution, 3-12
- Scan exposure, 3-13
- Storing, 4-17
- 2-Sided original, 3-4

## Scanning area, 14-34

## Searchable PDF, sending, 5-28

## Self-diagnostic display, 13-9

## Send Job List sample, 14-2

## Send jobs

- Changing the destination, 8-5
- Checking send job details, 8-2
- Checking/Changing the status of send jobs, 8-2
- Printing the send job status/log, 8-8
- Resending jobs, 8-7
- Send TX Report, 12-4, 14-3

## Sender names, registering, 1-17

## Sender's name, 14-34

## Sending a fax, 5-2

## Sending fax document manually, 1-31

## Sending methods

- Delaying send jobs, 5-14
- Job Done Notice, 5-16
- Previewing, 5-17
- Sending e-mail messages, 5-5
- Sending a fax, 5-2
- Sending an I-fax, 5-8
- Sending jobs to a file server, 5-10
- Sending jobs to User Inboxes, 5-13
- Sending with a subaddress, 7-2
- Stamping, 5-19

## Sending record, registering, 1-12

## Sequential broadcast, 1-39, 2-2, 14-35

## Sharpness, 4-13

## SMB, 14-35

## SMTP, 14-35

## Special Features, 4-2

## Specifications, 14-21

## Stamp, 5-19, 14-35

## Standard, 14-35

## Standard send settings, 9-14

## Subaddress, 14-36

## Subaddress, sending with, 7-2

## Subaddress books, 14-36

## Super fine, 14-36

## Super G3, xxii, 14-36

## Super G3 FAX Board, 14-23

## Super G3 Multi-Line Fax Board, 1-13, 14-24

## Symbols used in this manual, xiii

## System environment

- FTP, 2-12
- NetWare (IPX), 2-12
- WebDAV, 2-13
- Windows (SMB), 2-12

## System Settings table, 11-2

## T

- TCP/IP, 14-36
- Telephone Equipment, xxv
- Telephone line, selecting the type, 1-14
- Telephone line type, 14-36
- Text mode, 3-15
- Text/Photo mode, 3-14
- TIFF, 5-23, 14-36
- TIFF/JPEG Auto Select, 5-22, 9-15, 11-33, 11-40
- TIFF/PDF Auto Select, 5-22, 9-15, 11-33, 11-40
- Tone, 2-3, 7-8, 10-7, 14-36
- Trace & Smooth, 5-27
- Trademarks, xxiii
- Transmission time, 14-23, 14-37
- Troubleshooting
  - Error messages, 13-9
  - Other situations, 13-7
  - Q&A, 13-37
  - Receiving documents, 13-5
  - Sending documents, 13-2
- TTI, 14-37
- TX, 14-37
- TX settings, initializing, 9-33
- TX Terminal ID, printing, 9-28

## U

- UFR II, 14-37
- Ultra fine, 14-23, 14-37
- Unit name, registering, 1-18
- User inbox, 1-36, 2-20, 5-13
- User Preset keys
  - About User Preset keys, 4-17
  - Erasing scan settings, 4-20
  - Naming a User Preset key, 4-19
  - Storing scan settings, 4-17
- User Signature Certificate, confirming, 9-26
- Using a server, 2-27

User's data

- Printing, 12-12

- User's Data List sample, 14-19

## W

- WebDAV, sending, 9-31

## Y

- YCbCr, 9-32, 9-41, 14-38

## Z

Zoom ratio

- Auto zoom, 3-19

- Preset zoom, 3-17

- Zoom by percentage, 3-19









**CANON INC.**

30-2, Shimomaruko 3-chome, Ohta-ku, Tokyo 146-8501, Japan

**CANON U.S.A., INC.**

One Canon Plaza, Lake Success, NY 11042, U.S.A.

**CANON CANADA INC.**

6390 Dixie Road Mississauga, Ontario L5T 1P7, Canada

**CANON EUROPA N.V.**

Bovenkerkerweg 59-61 1185 XB Amstelveen, The Netherlands

**CANON FRANCE S.A.S.**

17, quai du Président Paul Doumer 92414 Courbevoie Cedex, France

**CANON (U.K.) LTD.**

Woodhatch, Reigate, Surrey, RH2 8BF, United Kingdom

**CANON DEUTSCHLAND GmbH**

Europark Fichtenhain A10, 47807 Krefeld, Germany

**CANON ITALIA S.p.A.**

Via Milano, 8 20097 San Donato Milanese (MI) Italy

**CANON LATIN AMERICA, INC.**

703 Waterford Way Suite 400 Miami, Florida 33126 U.S.A.

**CANON AUSTRALIA PTY. LTD**

1 Thomas Holt Drive, North Ryde, Sydney, N.S.W. 2113, Australia

**CANON CHINA CO., LTD**

15F Jinbao Building No.89 Jinbao Street, Dongcheng District, Beijing 100005, China

**CANON SINGAPORE PTE. LTD.**

1 HarbourFront Avenue #04-01 Keppel Bay Tower, Singapore 098632

**CANON HONGKONG CO., LTD**

19/F., The Metropolis Tower, 10 Metropolis Drive, Hunghom, Kowloon, Hong Kong