

Service Manual

iPF8000 series
iPF8000

Canon

Application

This manual has been issued by Canon Inc. for qualified persons to learn technical theory, installation, maintenance, and repair of products. This manual covers all localities where the products are sold. For this reason, there may be information in this manual that does not apply to your locality.

Corrections

This manual may contain technical inaccuracies or typographical errors due to improvements or changes in products. When changes occur in applicable products or in the contents of this manual, Canon will release technical information as the need arises. In the event of major changes in the contents of this manual over a long or short period, Canon will issue a new edition of this manual.

The following paragraph does not apply to any countries where such provisions are inconsistent with local law.

Trademarks

The product names and company names used in this manual are the registered trademarks of the individual companies.

Copyright

This manual is copyrighted with all rights reserved. Under the copyright laws, this manual may not be copied, reproduced or translated into another language, in whole or in part, without the written consent of Canon Inc.

COPYRIGHT © 2001 CANON INC.









Printed in Japan

Caution

Use of this manual should be strictly supervised to avoid disclosure of confidential information.



Symbols Used

This documentation uses the following symbols to indicate special information:

Symbol	Description
	Indicates an item of a non-specific nature, possibly classified as Note, Caution, or Warning.
	Indicates an item requiring care to avoid electric shocks.
	Indicates an item requiring care to avoid combustion (fire).
	Indicates an item prohibiting disassembly to avoid electric shocks or problems.
	Indicates an item requiring disconnection of the power plug from the electric outlet.
 Memo	Indicates an item intended to provide notes assisting the understanding of the topic in question.
 REF.	Indicates an item of reference assisting the understanding of the topic in question.
	Provides a description of a service mode.
	Provides a description of the nature of an error indication.

The following rules apply throughout this Service Manual:

1. Each chapter contains sections explaining the purpose of specific functions and the relationship between electrical and mechanical systems with reference to the timing of operation.

In the diagrams,  represents the path of mechanical drive; where a signal name accompanies the symbol, the arrow  indicates the direction of the electric signal.

The expression "turn on the power" means flipping on the power switch, closing the front door, and closing the delivery unit door, which results in supplying the machine with power.

2. In the digital circuits, '1' is used to indicate that the voltage level of a given signal is "High", while '0' is used to indicate "Low". (The voltage value, however, differs from circuit to circuit.) In addition, the asterisk (*) as in "DRMD*" indicates that the DRMD signal goes on when '0'.

In practically all cases, the internal mechanisms of a microprocessor cannot be checked in the field. Therefore, the operations of the microprocessors used in the machines are not discussed: they are explained in terms of from sensors to the input of the DC controller PCB and from the output of the DC controller PCB to the loads.

The descriptions in this Service Manual are subject to change without notice for product improvement or other purposes, and major changes will be communicated in the form of Service Information bulletins.

All service persons are expected to have a good understanding of the contents of this Service Manual and all relevant Service Information bulletins and be able to identify and isolate faults in the machine."

Contents

Chapter 1 PRODUCT DESCRIPTION

1.1 Product Overview	1- 1
1.1.1 Product Overview	1- 1
1.2 Features	1- 1
1.2.1 Features	1- 1
1.2.2 Printhead	1- 1
1.2.3 Ink tank	1- 2
1.2.4 Cutter unit	1- 2
1.2.5 Roll holder	1- 2
1.2.6 Media take-up unit (option)	1- 2
1.2.7 Consumables	1- 3
1.3 Product Specifications	1- 3
1.3.1 General Specifications	1- 3
1.4 Detailed Specifications	1- 5
1.4.1 Printing mode	1- 5
1.4.2 Interface Specifications	1- 5
1.5 Names and Functions of Components	1- 6
1.5.1 Front	1- 6
1.5.2 Rear	1- 7
1.5.3 Carriage	1- 7
1.5.4 Internal parts	1- 8
1.6 Basic Operation	1- 8
1.6.1 Operation panel	1- 8
1.6.2 Main menu	1- 9
1.7 Safety and Precautions	1- 16
1.7.1 Safety Precautions	1- 16
1.7.1.1 Moving Parts	1- 16
1.7.1.2 Adhesion of Ink	1- 17
1.7.1.3 Electrical Parts	1- 18
1.7.2 Other Precautions	1- 18
1.7.2.1 Printhead	1- 18
1.7.2.2 Ink tank	1- 19
1.7.2.3 Handling the Printer	1- 20
1.7.3 Precautions When Servicing Printer	1- 21
1.7.3.1 Notes on the Data Stored in the Printer	1- 21
1.7.3.2 Confirming the Firmware Version	1- 21
1.7.3.3 Precautions Against Static Electricity	1- 21
1.7.3.4 Precautions for Disassembly/Reassembly	1- 21
1.7.3.5 Self-diagnostic feature	1- 21
1.7.3.6 Disposing of the Lithium Battery	1- 21

Chapter 2 TECHNICAL REFERENCE

2.1 Basic Operation Outline	2- 1
2.1.1 Printer Diagram	2- 1
2.1.2 Print Driving	2- 1
2.2 Firmware	2- 1
2.2.1 Operation Sequence at Power-on	2- 1
2.2.2 Operation Sequence at Power-off	2- 2
2.2.3 Print Control	2- 3
2.2.4 Print Position Adjustment Function	2- 4

2.2.5 Head Management	2- 4
2.2.6 Printhead Overheating Protection Control	2- 4
2.2.7 Pause between Pages	2- 4
2.2.8 White Raster Skip	2- 4
2.2.9 Sleep mode.....	2- 4
2.3 Printer Mechanical System.....	2- 5
2.3.1 Outline.....	2- 5
2.3.1.1 Outline.....	2- 5
2.3.2 Ink Passage	2- 5
2.3.2.1 Ink Passage	2- 5
2.3.2.2 Ink Tank Unit.....	2- 6
2.3.2.3 Carriage Unit.....	2- 8
2.3.2.4 Printhead.....	2- 10
2.3.2.5 Purge Unit.....	2- 11
2.3.2.6 Maintenance Cartridge.....	2- 14
2.3.2.7 Air Flow	2- 14
2.3.3 Paper Path	2- 14
2.3.3.1 Outline.....	2- 14
2.3.3.2 Paper Path	2- 16
2.3.3.3 Cutter Unit.....	2- 16
2.4 Printer Electrical System	2- 16
2.4.1 Outline.....	2- 16
2.4.1.1 Overview	2- 16
2.4.2 Main Controller.....	2- 17
2.4.2.1 Main controller components.....	2- 17
2.4.3 Carriage Relay PCB.....	2- 19
2.4.3.1 Carriage relay PCB components	2- 19
2.4.4 Head Relay PCB	2- 19
2.4.4.1 Head relay PCB components.....	2- 19
2.4.5 Motor Driver	2- 19
2.4.5.1 Media take-up unit components.....	2- 19
2.4.6 Maintenance Cartridge Relay PCB	2- 20
2.4.6.1 Maintenance cartridge relay PCB components.....	2- 20
2.4.7 Power Supply.....	2- 20
2.4.7.1 Power supply block diagram	2- 20
2.5 Detection Functions with Sensors	2- 20
2.5.1 Cover system	2- 20
2.5.2 Ink passage system	2- 21
2.5.3 Carriage system.....	2- 23
2.5.4 Paper path system	2- 24
2.5.5 Humidity sensor	2- 24
2.5.6 Media take-up Unit.....	2- 25

Chapter 3 INSTALLATION

3.1 Installation	3- 1
3.1.1 Making Pre-Checks.....	3- 1
3.1.1.1 Making Pre-Checks.....	3- 1
3.1.2 Unpacking and Installation.....	3- 1
3.1.2.1 Checking the Contents.....	3- 1
3.1.2.2 Assembling the Stand	3- 3
3.1.2.3 Installing the Printer	3- 6
3.1.2.4 Installing the Basket.....	3- 7
3.1.2.5 Installing the Media Take-Up Unit (Option).....	3- 11
3.1.2.6 Removing Protection Materials	3- 17
3.1.3 Checking the Images/Operations.....	3- 19
3.1.3.1 Checking the Image and Operation	3- 19

Chapter 4 DISASSEMBLY/REASSEMBLY

4.1 Service Parts	4- 1
4.1.1 Service parts.....	4- 1
4.2 Disassembly/Reassembly.....	4- 1
4.2.1 Disassembly/Reassembly	4- 1
4.3 Points to Note on Disassembly and Reassembly	4- 4
4.3.1 Note on locations prohibited from disassembly	4- 4
4.3.2 Moving the carriage manually.....	4- 4
4.3.3 Units requiring draining of ink	4- 5
4.3.4 External covers.....	4- 5
4.3.5 Drive unit	4- 11
4.3.6 Carriage unit.....	4- 12
4.3.7 Ink tube unit.....	4- 16
4.3.8 Feeder unit	4- 17
4.3.9 Purge unit	4- 17
4.3.10 Ink tank unit	4- 18
4.3.11 Linear encoder.....	4- 21
4.3.12 Head management sensor	4- 22
4.3.13 PCBs.....	4- 22
4.3.14 Opening the cap and moving the wiper unit	4- 23
4.3.15 Opening and closing ink supply valves.....	4- 23
4.3.16 Draining the ink.....	4- 24
4.4 Applying the Grease	4- 25
4.4.1 Applying the Grease	4- 25
4.5 Adjustment and Setup Items	4- 27
4.5.1 Action to take after replacing the feed roller HP sensor, feed roller encoder, or feed roller	4- 27
4.5.2 Action to take after replacing the carriage unit or multi sensor.....	4- 27
4.5.3 Action to take after replacing the head management sensor	4- 27

Chapter 5 MAINTENANCE

5.1 Periodic Replacement Parts	5- 1
5.1.1 Periodic replacement parts.....	5- 1
5.2 Consumable Parts	5- 1
5.2.1 Consumable parts	5- 1
5.3 Periodic Maintenance	5- 1
5.3.1 Regular Maintenance	5- 1

Chapter 6 TROUBLESHOOTING

6.1 Troubleshooting.....	6- 1
6.1.1 Outline	6- 1
6.1.1.1 Outline of Troubleshooting.....	6- 1
6.1.2 Troubleshooting When Warnings Occur.....	6- 1
6.1.2.1 Ink Level: Check	6- 1
6.1.2.2 Check maint cartridge capacity.....	6- 1
6.1.2.3 Ink tank is empty. Replace the ink tank.	6- 1
6.1.2.4 No ink tank loaded. Check ink tank.....	6- 1
6.1.2.5 Close Ink Tank Cover	6- 1
6.1.2.6 End of paper feed. Cannot feed paper more.	6- 2
6.1.2.7 Paper Type Wrong.....	6- 2
6.1.2.8 GARO W12xx	6- 2
6.1.2.9 Check printed document	6- 2
6.1.2.10 Prepare for parts replacement. Call for service.....	6- 2
6.1.2.11 Parts replacement time has passed. Call for service.....	6- 3
6.1.3 Troubleshooting When Errors Occur	6- 3

6.1.3.1	03870001-2015 Cutter error	6- 3
6.1.3.2	03010000-200C/03010000-200E/03010000-200F/03010000-2017/03010000-2018/03016000-2010 multi sensor	6- 3
6.1.3.3	03031000-2E0F Upper cover sensor error	6- 3
6.1.3.4	03031101-2E10 Ink tank cover switch error	6- 3
6.1.3.5	03031000-2E11 Carriage cover sensor error	6- 4
6.1.3.6	03031000-2E12 Defective paper release lever	6- 4
6.1.3.7	03010000-2016/03010000-2E27 Paper feed error	6- 4
6.1.3.8	03010000-200D Cut media end error	6- 4
6.1.3.9	03010000-2E1F/03060000-2E14/03060A00-2E00/03061000-2E15/03063000-2E08/03860002-2E02/03860002-2E0A/ 03860002-2E0C Path mismatch error	6- 5
6.1.3.10	03862000-2E09 Insufficient roll media error	6- 5
6.1.3.11	03890000-2920 Media take-up motor error	6- 5
6.1.3.12	03890000-2921 Media take-up paper detection sensor error	6- 5
6.1.3.13	03060A00-2E1B Roll media end error	6- 5
6.1.3.14	03861001-2405/03861001-2406 Borderless printing error	6- 6
6.1.3.15	03810104-2500/03810101-2501/03810102-2502/03810103-2503/03810112-2504/03810113-2505/03810106-2506/ 03810105-2508/03810115-2509/03810107-250A/03810109-250B/03810108-250C No ink error	6- 6
6.1.3.16	03830104-2520/03830101-2521/03830102-2522/03830103-2523/03830112-2524/03830113-2525/03830106-2526/ 03830105-2528/03830115-2529/03830107-252A/03830109-252B/03830108-252C Ink tank is not installed. (This error occurs when the ink tank is replaced.)	6- 6
6.1.3.17	03800204-2540/03830201-2541/03830202-2542/03830203-2543/03830212-2544/03830213-2545/03830206-2546/ 03830205-2548/03830215-2549/03830207-254A/03830209-254B/03830208-254C Invalid ink tank ID	6- 6
6.1.3.18	03830304-2560/03830301-2561/03830302-2562/03830303-2563/03830312-2564/03830313-2565/03830306-2566/ 03830305-2568/03830305-2568/03830315-2569/03830307-256A/03830309-256B/03830308-256C Ink tank EEPROM error ...	6- 6
6.1.3.19	03810204-2570/03810201-2571/03810202-2572/03810203-2573/03810212-2574/03810213-2575/03810206-2576/ 03810205-2578/03810215-2579/03810207-257A/03810209-257B/03810208-257C Ink low error (occurs when replacing the printhead)	6- 6
6.1.3.20	03810204-2580/03810201-2581/03810202-2582/03810203-2583/03810212-2584/03810213-2585/03810206-2586/ 03810205-2588/03810215-2589/03810207-258A/03810209-258B/03810208-258C Ink low error (occures when cleaning B is executed)	6- 7
6.1.3.21	03810204-2590/03810201-2591/03810202-2592/03810203-2593/03810212-2594/03810213-2595/03810206-2596/ 03810205-2598/03810215-2599/03810207-259A/03810209-259B/03810208-259C Ink low error (occures when printing)	6- 7
6.1.3.22	03800301-2801/03800201-2802/03800401-2803/03800201-2812/03800302-2809/03800202-280A/03800402-280B/ 03800202-2813 Printhead error	6- 7
6.1.3.23	03800101-2800/03800102-2808/03800201-2804/03800202-2807 Printhead installing error	6- 7
6.1.3.24	03800501-280D/03800502-280E Defective printhead nozzle	6- 8
6.1.3.25	03841201-2816/03841201-2817/03841101-2818/03841001-2819/03841001-281B Maintenance cartridge error	6- 8
6.1.3.26	03010000-2820/03010000-2821/03010000-2822/03010000-2823/03130031-2F32/03010000-2F33/ Adjustment error	6- 8
6.1.3.27	03130031-260E Gap detection error	6- 8
6.1.3.28	03130031-260F Gap adjustment error	6- 8
6.1.3.29	03130031-2618 VH voltage abnormality error	6- 9
6.1.3.30	03800500-2F2F/03800500-2F30 Head management sensor error	6- 9
6.1.3.31	03130031-2F16 Mist fan error	6- 9
6.1.3.32	03130031-2F17 Suction fan error	6- 9
6.1.3.33	03030000-2E21 IEEE1394 Error	6- 9
6.1.3.34	03130031-2F25 Carriage home position error	6- 10
6.1.3.35	03130031-2F26/03130031-2F27 Carriage motor error	6- 10
6.1.3.36	03130031-2F1F/03130031-2F20 Defective sensor in purge unit	6- 10
6.1.3.37	03130031-2F22/03130031-2F23/03130031-2F2D Purge motor driving error	6- 10
6.1.3.38	03130031-2F2A Feed roller home position error	6- 10
6.1.3.39	03130031-2F3A valve open/close error	6- 10
6.1.3.40	03130031-2F2E Roll media feeding error	6- 11
6.1.3.41	03130031-2F28 Lift motor time out error	6- 11
6.1.3.42	03130031-2F13 A/D Converter external trigger output stopped	6- 11
6.1.3.43	03130031-2F14 ASIC Register cannot be written	6- 11
6.1.3.44	03900001-4042/03900001-4049 Firmware error	6- 11
6.1.3.45	E194-4034 Sensor calibration error	6- 11
6.1.4	Troubleshooting When Service Call Errors Occur	6- 12
6.1.4.1	E141-4046 Recovery system's count error	6- 12
6.1.4.2	E144-4047 Supply system's count error	6- 12
6.1.4.3	E146-4001 Waste ink count full	6- 12
6.1.4.4	E161-403E/E161-403F Abnormally high head temperature	6- 12
6.1.4.5	E194-404A Non-discharge detection count error	6- 12

6.1.4.6 E196-4040/E196-4041/E196-4042/E196-4043/E196-4044/E196-4045 Main controller PCB error.....	6- 12
6.1.4.7 E198-401C/E198-401D/E198-401E RTC error.....	6- 12
6.2 Location of Connectors and Pin Arrangement.....	6- 13
6.2.1 Main controller PCB.....	6- 13
6.2.2 Carriage relay PCB.....	6- 22
6.2.3 Head relay PCB.....	6- 30
6.3 Version Up.....	6- 37
6.3.1 Firmware Update Tool.....	6- 37
6.4 Service Tools.....	6- 38
6.4.1 List of Tools.....	6- 38

Chapter 7 SERVICE MODE

7.1 Service Mode.....	7- 1
7.1.1 Service Mode.....	7- 1
7.1.2 Map of the Service mode.....	7- 1
7.1.3 Details for Service mode.....	7- 6
7.2 Special Mode.....	7- 12
7.2.1 Special Modes for Servicing.....	7- 12

Chapter 8 ERROR CODE

8.1 Outline.....	8- 1
8.1.1 Outline.....	8- 1
8.2 Warning Table.....	8- 1
8.2.1 Warnings.....	8- 1
8.3 Error Table.....	8- 2
8.3.1 Errors.....	8- 2
8.4 Service Call Table.....	8- 5
8.4.1 Service call errors.....	8- 5

Chapter 1 PRODUCT DESCRIPTION

Contents

1.1 Product Overview	1-1
1.1.1 Product Overview	1-1
1.2 Features	1-1
1.2.1 Features	1-1
1.2.2 Printhead	1-1
1.2.3 Ink tank	1-2
1.2.4 Cutter unit	1-2
1.2.5 Roll holder	1-2
1.2.6 Media take-up unit (option)	1-2
1.2.7 Consumables	1-3
1.3 Product Specifications.....	1-3
1.3.1 General Specifications	1-3
1.4 Detailed Specifications	1-5
1.4.1 Printing mode.....	1-5
1.4.2 Interface Specifications.....	1-5
1.5 Names and Functions of Components	1-6
1.5.1 Front.....	1-6
1.5.2 Rear	1-7
1.5.3 Carriage.....	1-7
1.5.4 Internal parts	1-8
1.6 Basic Operation.....	1-8
1.6.1 Operation panel	1-8
1.6.2 Main menu	1-9
1.7 Safety and Precautions	1-16
1.7.1 Safety Precautions.....	1-16
1.7.1.1 Moving Parts	1-16
1.7.1.2 Adhesion of Ink.....	1-17
1.7.1.3 Electrical Parts	1-18
1.7.2 Other Precautions.....	1-18
1.7.2.1 Printhead	1-18
1.7.2.2 Ink tank.....	1-19
1.7.2.3 Handling the Printer	1-20
1.7.3 Precautions When Servicing Printer	1-21
1.7.3.1 Notes on the Data Stored in the Printer.....	1-21
1.7.3.2 Confirming the Firmware Version.....	1-21
1.7.3.3 Precautions Against Static Electricity.....	1-21
1.7.3.4 Precautions for Disassembly/Reassembly.....	1-21
1.7.3.5 Self-diagnostic feature	1-21
1.7.3.6 Disposing of the Lithium Battery.....	1-21

1.1 Product Overview

1.1.1 Product Overview

This printer is a large-format printer that prints in a maximum width of 44 inches with high-speed photographic picture quality. This printer is a stand-mounted type printer and is capable of output to either roll media or cut sheet.

Product Components

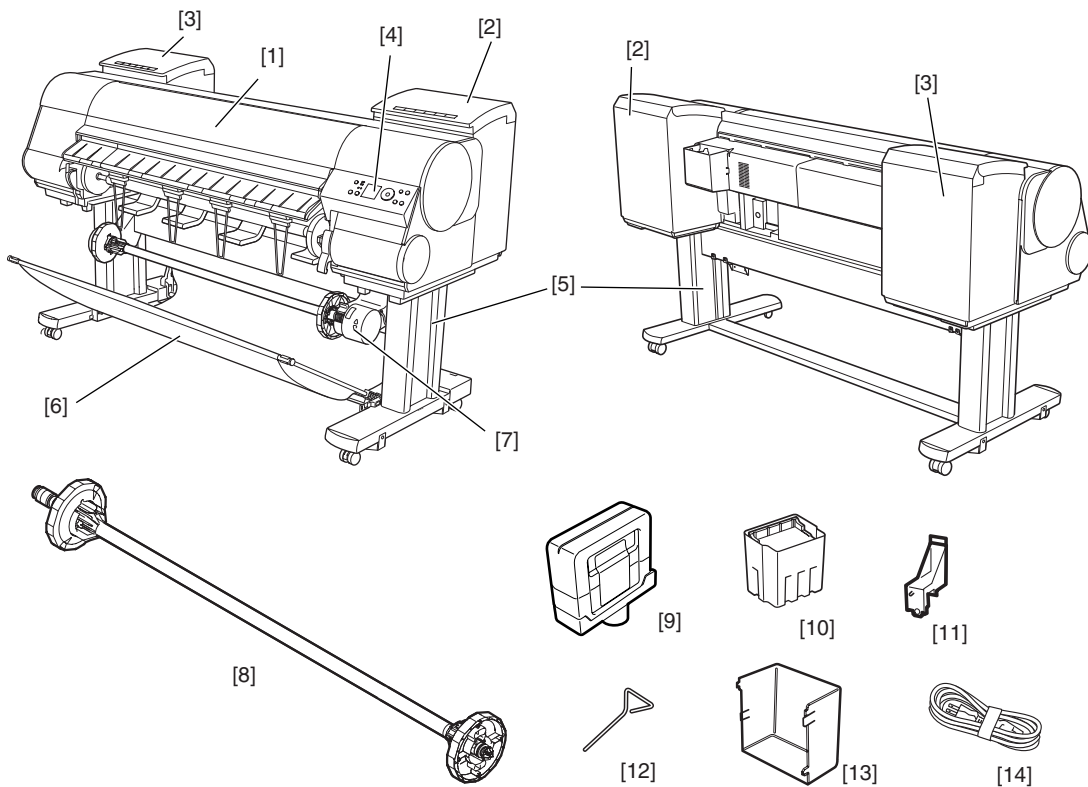

[1]	Upper cover	[8]	Roll holder
[2]	Ink tank cover unit (R)	[9]	Ink tank
[3]	Ink tank cover unit (L)	[10]	Printhead
[4]	Operation panel	[11]	Belt stopper
[5]	Stand (USA: Bundled/ Others: Option)	[12]	Hex key wrench
[6]	Basket	[13]	Pocket
[7]	Media take-up unit (Option)	[14]	Power cord

F-1-1
T-1-1

1.2 Features

1.2.1 Features

- Media pass in widths up to 44 inches (1117.6 mm).
- Large ink tanks save the need for their replacement.
- Uninterrupted printing from subtanks.
- BK and MBK inks are loaded concurrently to eliminate the need for their replacement.
- Media take-up unit (option) is supported.
- Media take-up unit (option) can be mounted concurrently with a basket.
- Durability will be added by maintenance kit.
- Large LCD panel displays more information and makes operations easier.
- High resolutions of 2400 x 1200 dpi maximum, coupled with the exceptionally light-fast, water-proof and ozone-proof 12-color pigment inks of MBK, BK, PC, C, PM, M, Y, R, G, B, GY, and PGY, deliver high-quality photographic picture quality.
- USB2.0 Hi-speed interface and 10Base-T/100Base-TX in standard support of a TCP/IP network, plus optional support of IEEE1394.
- Barcodes printed on roll media make remaining roll media management possible.
- Borderless four-side printing support (roll media) removes laborious cutting work, easing the job of creating posters to a significant degree.
- High-speed printing with a 1-inch head for each color (1,280 nozzles), under bidirectional print control.
- Ink supply through tubing to a completely independent printhead and large-capacity ink tanks.

1.2.2 Printhead

The printhead that mounts on the carriage is an integrated six-color disposable printhead.

It has 2,560 nozzles for each color, comprising two trays of 1,280 nozzles each arranged in a zigzag pattern.

If print quality remains unimproved even after a specified cleaning operation, replace the printhead. Replacement about one year after the date of initial unpacking is also recommended.

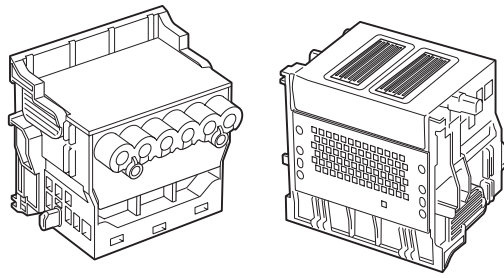

F-1-2

1.2.3 Ink tank

Ink tanks are disposable.

The ink tanks come with 12 colors: mat black (MBK), black (BK), photocyan (PC), cyan (C), photomagenta (PM), magenta (M), yellow (Y), red (R), blue (B), green (G), gray (GY) and photogray (PGY). Each of these inks are pigment ink.

The tanks are also available in two capacities: 330 mL and 700 mL.

Each tank is furnished with a notch for preventing incorrect installation, which will allow the tank to be installed only at the position marked in the right color.

An ink tank should be replaced when an ink tank replacement prompt message appears or when six months expire after the date of initial unpacking, whichever occurs earlier.

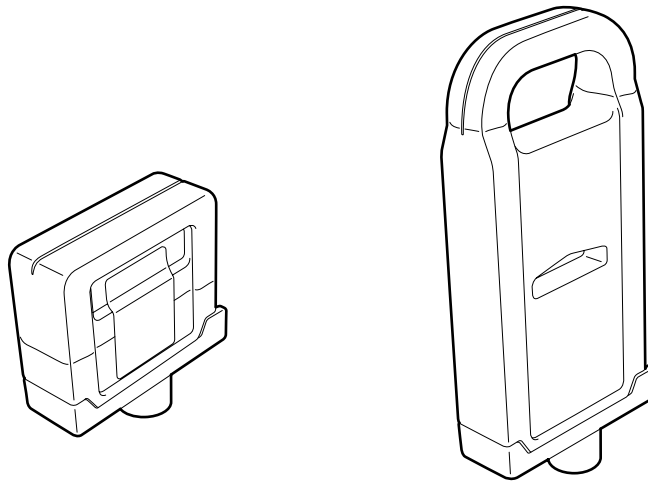

F-1-3

1.2.4 Cutter unit

The cutter unit that mounts on the carriage unit is disposable.

Replace the cutter unit when it gets dull.

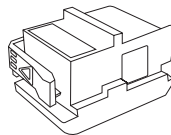

F-1-4

1.2.5 Roll holder

The printer comes with a roll holder for paper tubes having an inside diameter of 2 inches as standard. It supports an optional roller holder for paper tubes having an inside diameter of 3 inches.

Both roll holders clamp the paper tubes of roll media with an outside diameter of 150 mm or less from inside.

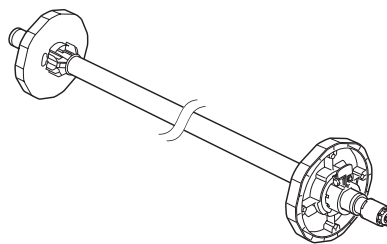

F-1-5

1.2.6 Media take-up unit (option)

The media take-up unit takes up roll media, ranging in width from 17 to 44 inches, on a 2 or 3-inch paper tube in roll form after they are printed by the host computer. Taking up begins automatically when a sensor attached to the bottom of the stand detects a roll delivered after printing falling down due to the weight of a weight roller.

Rolls may also be manually taken up by using a button on the media take-up unit.

The media take-up unit has an overload protection feature to prevent accidents while taking up rolls. (The feature will shut down the motor automatically when an overload occurs while taking up a roll.)

Additional features of the media take-up unit include:

- An adapter may be installed to support a 3-inch paper tube.
- Rolls can be rewound by feeding them backward to visually check images.
- Weight rollers varying in length to suit specific roll widths ensure added take-up efficiency.
- The printer detects errors in the media take-up unit by itself.
- Linked with the printer's sleep mode.

1.2.7 Consumables

Printhead

The expendable printhead is the same as the one that comes with the printer.

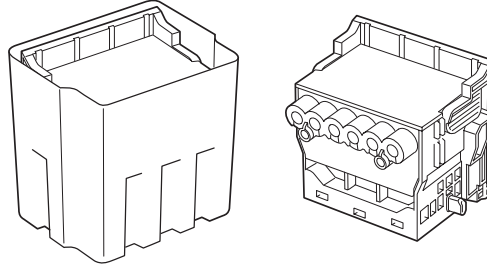

F-1-6

Ink tanks

Expendable ink tanks contain 12 colors: mat black, black, photocyan, cyan, photomagenta, magenta, yellow, red, blue, green, gray and photogray. Each tank is available in two capacities: 330 mL and 700 mL.

Usable for six months after unpacking.

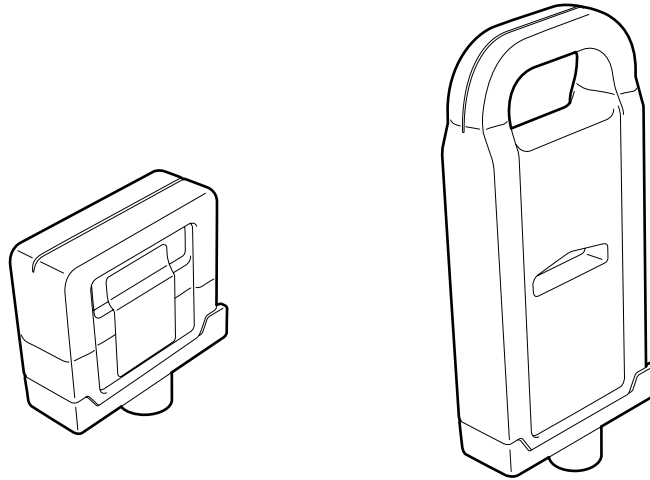

F-1-7

Maintenance cartridge

The expendable maintenance cartridge is the same as the one that comes with the printer.

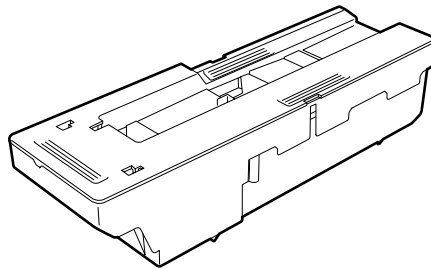

F-1-8

1.3 Product Specifications

1.3.1 General Specifications

Type	Bubblejet printer (stand model)
Feeding system	Roll media: Manual (front loading) Cut media: Paper tray (front loading)
Feeding capacity	Roll media: 1 roll (up to 150 mm outside diameter) Standard roll holder: Paper tube, 50.8 mm (2") inside diameter Cut media: 1
Delivery method	Forward delivery, face up

Sheet delivery capability	1 (loaded in a basket)
Cutter	Automatic cross-cutter (round blade)
Type of media	Plain Paper, Plain Paper(High Quality), Plain Paper(High Grade), Recycled Coated Paper, Coated Paper, Heavyweight Coated Paper, Extra Heavyweight Coated Paper, Premium Matte Paper, Glossy Photo Paper, Semi-Glossy Photo Paper, Heavyweight Glossy Photo Paper, Heavyweight SemiGloss Photo Paper, Synthetic Paper, Adhesive Synthetic Paper, Backlit Film, Backprint Film, Flame-Resistant Cloth, Fabric Banner, Thin Fabric Banner, Proofing Paper, Fine Art Photo, Fine Art Heavyweight Photo, Fine Art Textured, Fine Art Watercolor, Fine Art Block Print, Canvas Matte, Canvas Semi-Glossy, Japanese Paper Washi, Colored Coated Paper, CAD Tracing Paper, CAD Translucent Matte Film, CAD Clear Film
Supported thickness	0.07 mm to 0.8 mm
Media size (Roll media)	Width: 254 mm (10") to 1117.6 mm (44") Length: 203.2 mm (8") to 18000 mm (709") * Outer diameter of roll :150mm or less * The maximum amount of length may vary by the using operating system or the applications.
Media size (Cut sheet)	Width: 203.2 mm (8") to 1117.6 mm (44") Length: 203.2 mm (8") to 1600 mm (63")
Printable area (Roll media)	Internal area, excluding a 5-mm top, bottom and left and right margins. * The printable area may vary with each type of paper media used.
Printable area (Cut sheet)	Internal area, excluding a 5-mm top margin, a 23-mm bottom margin and 5-mm left and right margins.
Printing recommendation area (Roll media)	Internal area, excluding a 20-mm top margin, a 5-mm bottom margin and 7-mm left and right margins.
Printing recommendation area (Cut sheet)	Internal area, excluding a 20 mm top margin, a 23-mm bottom margin and 7-mm left and right margins.
Borderless printing	* Roll media only width: 254 mm (10"), 355.6 mm (14"), 406.4 mm (16"), 515 mm (20.28"), 594 mm (23.39"), 609.6 mm (24"), 841 mm (33.11"), 914.4 mm (36"), 1030 mm (40.55"), 1066.8 mm (42"),
Emulation	None.
Interface	USB 2.0 Hi-speed Network (10BASE-T/100BASE-TX) IEEE1394 (optional)
Printhead/Ink Tank type	Independent printhead/ink tanks
Printhead	PF-02 Structure: Integrated six-color assembly Number of nozzles: 2,560 for each color
Ink tank	PFI-301 MBK/BK/PC/C/PM/M/Y/R/G/B/GY/PGY PFI-701 MBK/BK/PC/C/PM/M/Y/R/G/B/GY/PGY Ink type: Pigment ink Ink tank capacity: PFI-301 330 mL, PFI-701 700 mL
Detection functions (Cover system)	Cover open/closed detection: Yes Left and right ink tank cover open/closed detection: Yes
Detection functions (Ink passage system)	Ink tank presence/absence detection: Yes Remaining ink level detection: Yes Maintenance cartridge presence/absence detection: Yes Used ink tank full detection: Yes
Detection functions (Carriage system)	Printhead presence/absence detection: Yes Carriage position detection: Yes Carriage home position detection: Yes Carriage cover open/closed detection: Yes Carriage temperature detection: Yes Printhead height detection: Yes Non-discharging nozzle detection: Yes Non-discharging nozzle backup feature: Yes
Detection functions (Paper path system)	Paper presence/absence detection: Yes Paper width detection: Yes Skew detection: Yes Paper release lever position detection: Yes Remaining roll media detection: Yes Feed roller rotation detection: Yes
Operating noise	Operating: Approx. 54dB (A) or less Idle: Approx. 35dB (A) or less
Operating environment	Operating temperature: 5oC to 35oC Relative humidity: 10% to 90%RH
Print quality guaranteed environment	Guaranteed print quality temperature: 15oC to 30oC Relative humidity: 10% to 80%RH
Power supply	AC100 to 240V, 1.9A, 50/60Hz
Power consumption (Maximum)	Maximum: 190W
Power consumption	Sleep mode: 5W or less (100 to 120V, 8W or less when IEEE1394 installed) 6W or less (220 to 240V, 9W or less when IEEE1394 installed) Powered off: 1W or less
Printer unit dimensions (WxDxH)	1893 mm x 975 mm x 1144 mm (including stand and basket)

Weight	Printer: Approx. 111kg Stand: Approx. 28kg Media take-up unit: Approx. 5kg
--------	--

1.4 Detailed Specifications

1.4.1 Printing mode

T-1-2

Media Type	Print Priority	Print Quality	Processing resolution (dpi)	Print resolution (dpi)	Print pass	Printing direction (*1)
Plain Paper Plain Paper(High Quality) Plain Paper(High Grade)	Image	draft	300	1200x1200	2	Bi-directional
		standard	300	1200x1200	4	Bi-directional
		High	600	2400x1200	8	Bi-directional
	Line drawing /Text	draft	600	1200x1200	2	Bi-directional
		standard	600	1200x1200	4	Bi-directional
		Office document	standard	600	1200x1200	4
Recycled Coated Paper Coated Paper Heavyweight Coated Paper Extra Heavyweight Coated Paper	Image	standard	300	1200x1200	4	Bi-directional
		High	600	2400x1200	8	Bi-directional
		Highest	600	2400x1200	12	Bi-directional
Premium Matte Paper Glossy Photo Paper Semi-Glossy Photo Paper Heavyweight Glossy Photo Paper Heavyweight SemiGlos Photo Paper Synthetic Paper Adhesive Synthetic Paper Backlit Film Backprint Film Flame-Resistant Cloth Fabric Banner Thin Fabric Banner Proofing Paper Fine Art Photo Fine Art Heavyweight Photo Fine Art Textured Fine Art Watercolor Fine Art Block Print Canvas Matte Canvas Semi-Glossy Japanese Paper Washi	Image	standard	600	1200x1200	6	Bi-directional
		High	600	2400x1200	8	Bi-directional
		Highest	600	2400x1200	16	Bi-directional
Colored Coated Paper	Image	standard	300	1200x1200	4	Bi-directional
		High	600	2400x1200	8	Bi-directional
CAD Tracing Paper CAD Translucent Matte Film CAD Clear Film	Line drawing /Text	draft	600	1200x1200	2	Bi-directional
		standard	600	1200x1200	4	Bi-directional
		High	600	2400x1200	8	Bi-directional

*1 Uni-directional can be selected optionally from the printer driver.

1.4.2 Interface Specifications

a. USB (standard)

- (1) Interface type
USB 2.0, Full speed (12 Mbits/sec), Hi-speed (480 Mbits/sec)
- (2) Data transfer system
Control transfer
Bulk transfer
- (3) Signal level
Compliant with the USB standard.
- (4) Interface cable
Twisted-pair shielded cable, 5.0 m max.
Compliant with the USB standard.
Wire materials: AWG No.28, data wire pair (AWF: American Wire Gauge)
AWG No.20 to No.28, power distribution wire pair
- (5) Interface connector
Printer side: Series B receptacle compliant with USB standard
Cable side: Series B plug compliant with USB standard

b. Network (standard)

- (1) Interface type
Interface compliant with IEEE802.3
- (2) Data transfer system
10Base-T/100Base-TX
- (3) Signal level
Input: Threshold
10Base-T: Max. +585 mV, Min. +300 mV
100Base-TX: Turn-on +1000 mV diff pk-pk, Turn-off +200 mV diff pk-pk
Output:
10Base-T: +2.2 V to +2.8 V
100Base-TX: +0.95 to +1.05 V
- (4) Interface cable
Category 5 (UTP or FTP) cable, 100 m or shorter

Compliant with ANSI/EIA/TIA-568A or ANSI/EIA/TIA-568B

- (5) Interface connector
Printer side: Compliant with IEEE802.3, ANSI X3.263, ISO/IEC60603-7

c. IEEE1394 (option)

- (1) Interface type
Interface compliant with IEEE1394-1995, P1394a (Version 2.0)
- (2) Data transfer system
Asynchronous transfer
- (3) Signal level
Input:
Differential input voltage:
During S100 settlement: +173 mV to +260 mV
During data reception: +142 mV to +260 mV
During S200 settlement: +171 mV to +262 mV
During data reception: +132 mV to +260 mV
During S400 settlement: +168 mV to +265 mV
During data reception: +118 mV to +260 mV
Output:
Differential output voltage: +172 mV to +265 mV
- (4) Interface cable
Twisted-pair shielded cable, 4.5 m max.
Compliant with IEEE1394-1995 standard or P1394a (Version 2.0) standard
- (5) Interface connector
Printer side: 6-pin connector (socket) compliant with IEEE1394 standard
Cable side: 6-pin connector (plug) compliant with IEEE1394 standard
Cable side: RJ-45 type compliant with ANSI/EIA/TIA-568A or ANSI/EIA/TIA-568B

1.5 Names and Functions of Components

1.5.1 Front

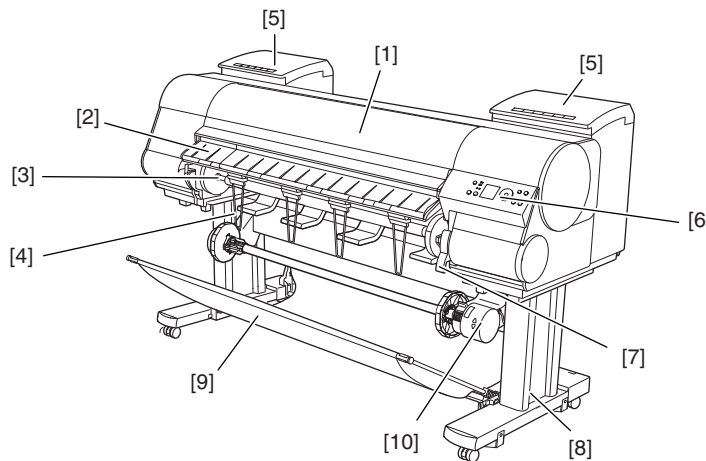

F-1-9
T-1-3

- | | |
|-------------------------|--|
| [1] Upper cover | Open this cover to install a printhead, load media or clear jammed paper inside the printer. |
| [2] Delivery guides | Allow printed paper to be delivered. Open these guides to load a roll. |
| [3] Roll holder | Load a roll on this holder. |
| [4] Delivery support | Keeps printed paper from being caught by the roll holder or in the paper slot. |
| [5] Ink tank cover | Open this cover to replace the ink tank. |
| [6] Operation panel | Use this panel to operate the printer and check its status. |
| [7] Release lever | Releases the paper retainer. Pull up this lever to front of the printer to load paper. |
| [8] Stand | The base on which the printer mounts, furnished with casters. |
| [9] Basket | Cloth tray that catches the printed paper. |
| [10] Media take-up unit | Takes up printed rolls automatically. |

1.5.2 Rear

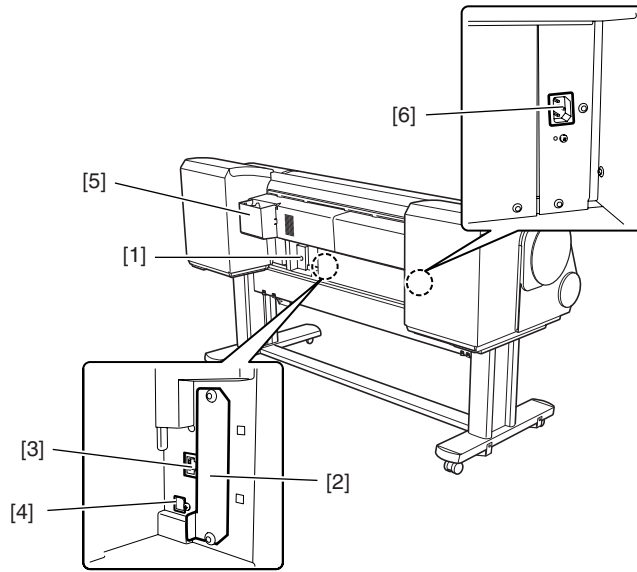

F-1-10
T-1-4

- | | | |
|-----|---|---|
| [1] | Media take-up unit power cord connector | Connect the power cord of the media take-up unit to this connector. |
| [2] | Expansion board slot | Mount an expansion PCB on this slot. |
| [3] | Ethernet connector | Connect the Ethernet cable to this connector. |
| [4] | USB port | Connect the USB cable to this port. |
| [5] | Accessory pocket | Holds printer manuals, assembly tools, and other items. |
| [6] | Power cord connector | Connect the power cord to this connector. |

1.5.3 Carriage

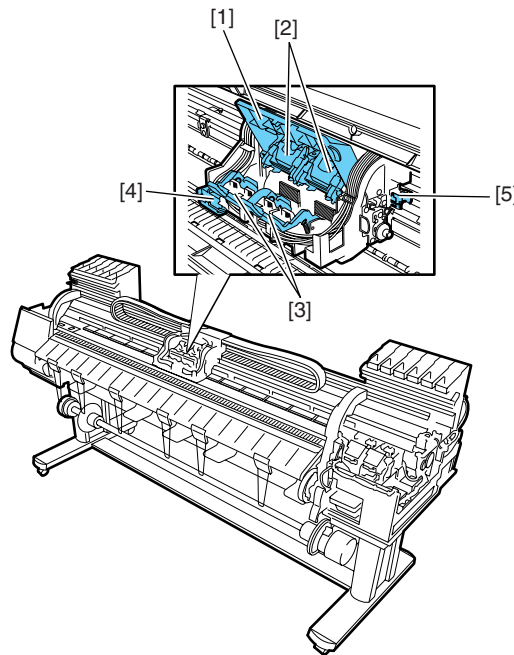

F-1-11
T-1-5

- | | | |
|-----|-----------------------|---|
| [1] | Carriage cover | Protects the carriage unit. |
| [2] | Printhead fixer cover | Clamps the printhead. |
| [3] | Printhead fixer lever | Locks the printhead lock cover. |
| [4] | Cutter unit | Round-blade cutter used to cut paper automatically. |
| [5] | Shaft cleaner | Keeps the carriage shaft clean. |

1.5.4 Internal parts

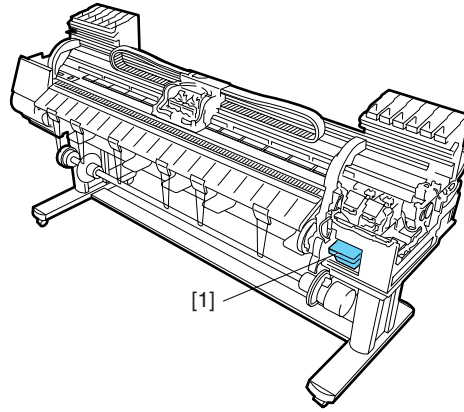

F-1-12
T-1-6

[1] Maintenance cartridge

The cartridge that vacuums and collects excess ink.

1.6 Basic Operation

1.6.1 Operation panel

This section describes the function of the buttons and the meaning of the LEDs on the operation panel.

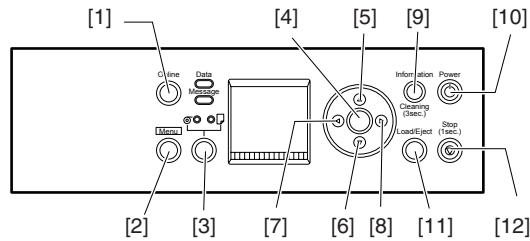

F-1-13
T-1-7

- | | | |
|------|-----------------------|--|
| [1] | [Online] button | This button switches between online status and offline status. |
| [2] | [Menu] button | This button displays the main menu. |
| [3] | [Paper source] button | This button switches the paper source between roll media and cut sheets. |
| [4] | [OK] button | This button sets or executes the selected value or operation. |
| [5] | [▲] button | Offline: This button functions as a manual feed button and reverse-feeds the media.
Menu: This button functions as a selector button and is used to display the previous option or the previous item/setting. |
| [6] | [▼] button | Offline: This button functions as a manual feed button and feeds the media.
Menu: This button functions as a selector button and is used to display the next option or the next item/setting. |
| [7] | [◀] button | Menu: This button is used to return to the next higher-level menu. |
| [8] | [▶] button | Menu: This button is used to go to the next lower-level menu. |
| [9] | [Information] button | This button displays a submenu. Information about the ink and media each time you press this button. Head cleaning A is carried out when this button is held pressed for at least 3 seconds. |
| [10] | [Power] button | This button turns on/off the printer.
Power off: This button turns on the printer.
Power on : Holding down this button for about a second to turns off the printer. |
| [11] | [Load/Eject] button | When the media is not loaded: Displays the instructions of loading the media.
When the media is loaded: Displays the instructions of removing the media. |
| [12] | [Stop] button | Hold down for at least a second to cancel print jobs in progress or end the ink drying period. |

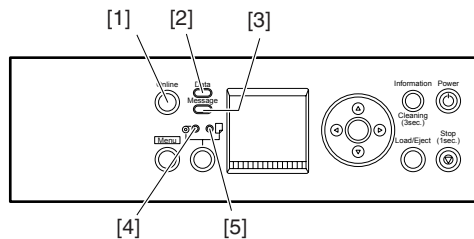

F-1-14
T-1-8

[1] Online lamp (green)

On: The printer is in online status.
Off: The printer is in offline status.

[2]	Data lamp (green)	Flashing(when printing) :this lamp indicates that the printer is receiving or processing a print job. Flashing(when not printing):this lamp indicates that the print job is paused or firmware data is being received. Off: This indicates that there is no print job.
[3]	Message lamp (orange)	On: This indicates that a warning message is displayed. Flashing: This indicates that an error message is displayed. Off: This indicates that the printer is normal or the power is turned off.
[4]	Roll media lamp (green)	On: This indicates that the or roll media is selected as the paper source. Off: This indicates that the or cut sheet is selected as the paper source.
[5]	Cut sheet lamp (green)	On: This indicates that the or cut sheet is selected as the paper source. Off: This indicates that the or roll media is selected as the paper source.

1.6.2 Main menu

The printer has a Main Menu which provides the user with access to various adjusting and configuring features, for example: adjusting print position; performing cleaning or other maintenance features; auto-cutting, ink drying time and other print settings; message language and other parameter settings.

1. Main menu operations

a) How to enter the Main Menu

To enter the Main menu, press the [Menu] button.

b) How to exit the Main Menu

Press the [Online] button to exit the Main menu.

c) Buttons used in the Main Menu

- Selecting menus and parameters: [▲] button or [▼] button

- Entering a higher-level menu: [◀] button

- Entering a lower-level menu: [▶] button

- Setting menus and parameters: [OK] button

2. Map of the main menu

The hierarchy of menus and parameters in the Main Menu is as shown below.

MAIN MENU

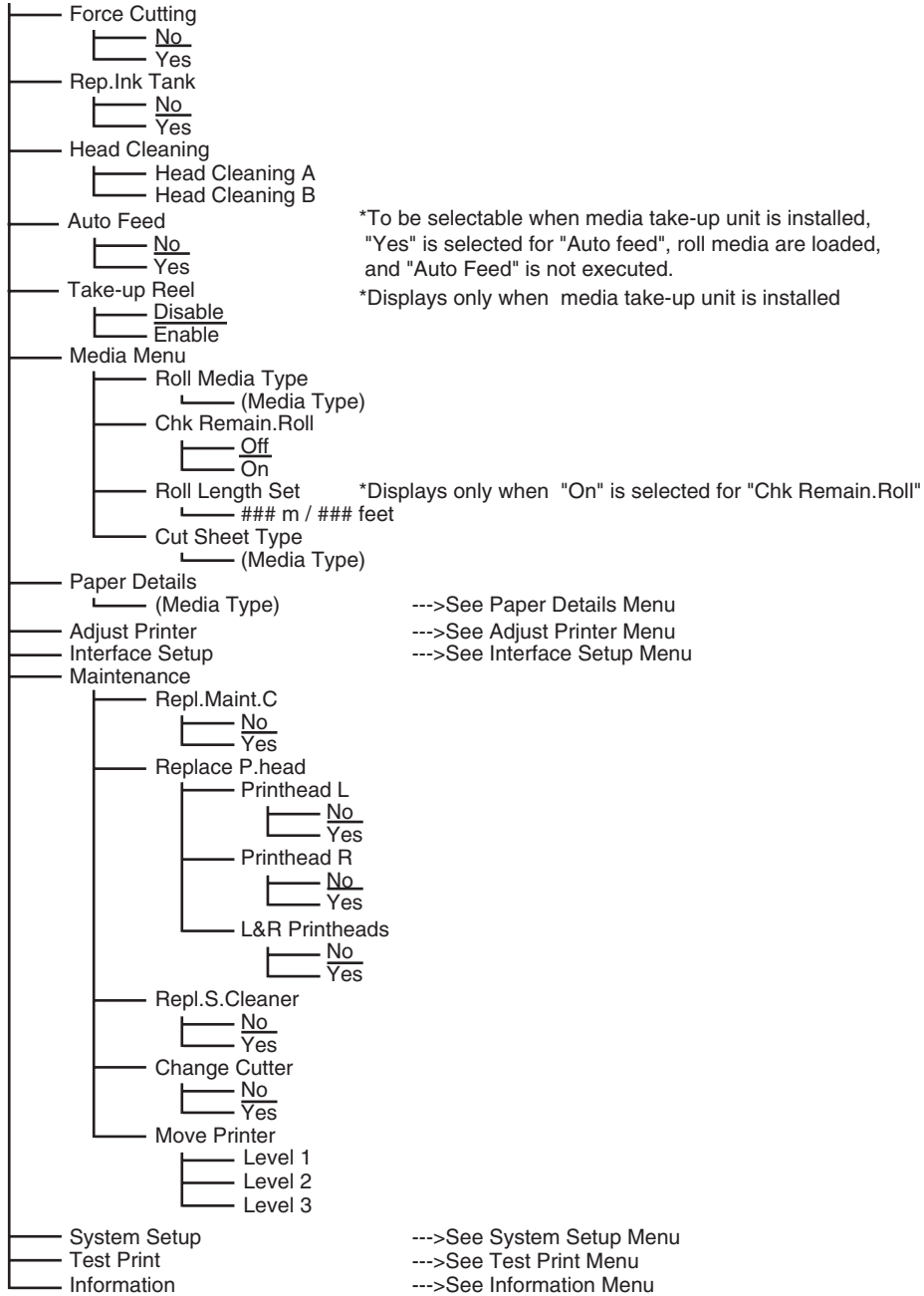

Paper Details Menu

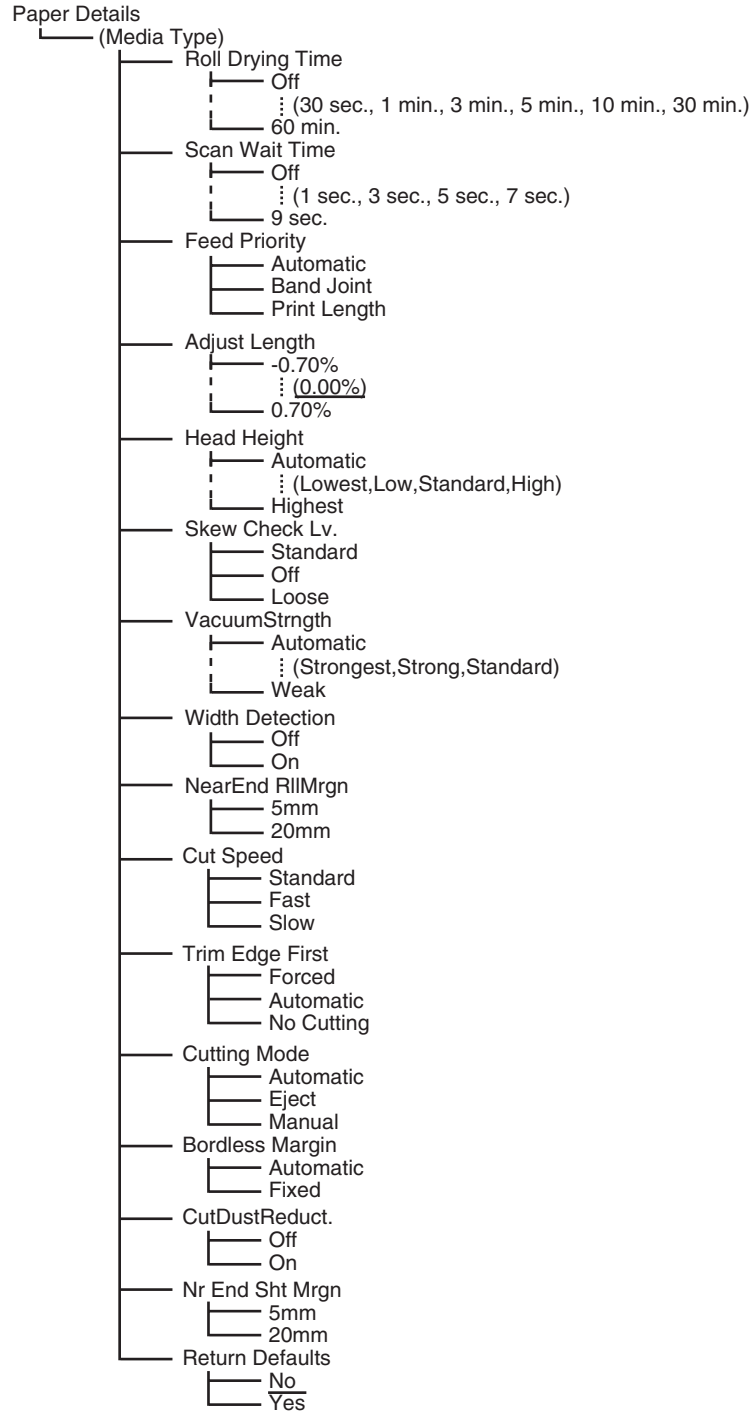

F-1-16

Adjust Printer Menu

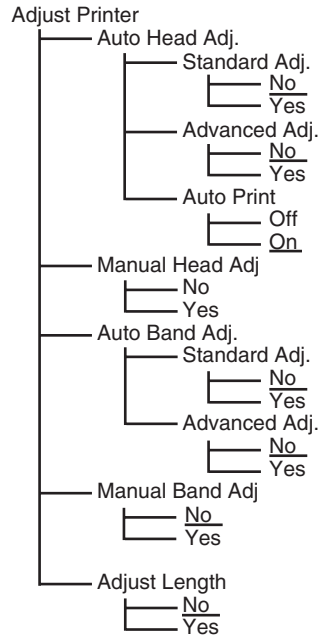

F-1-17

Interface Setup Menu

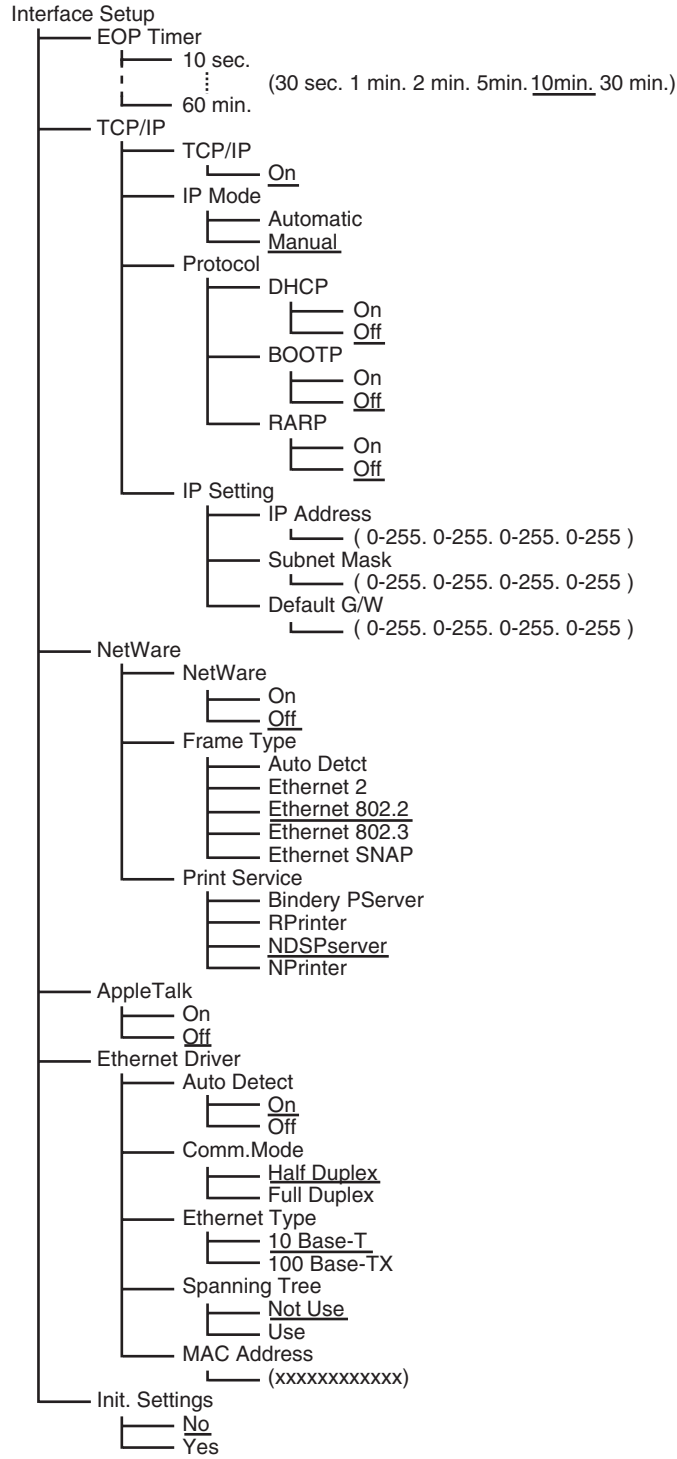

F-1-18

System Setup Menu (1/2)

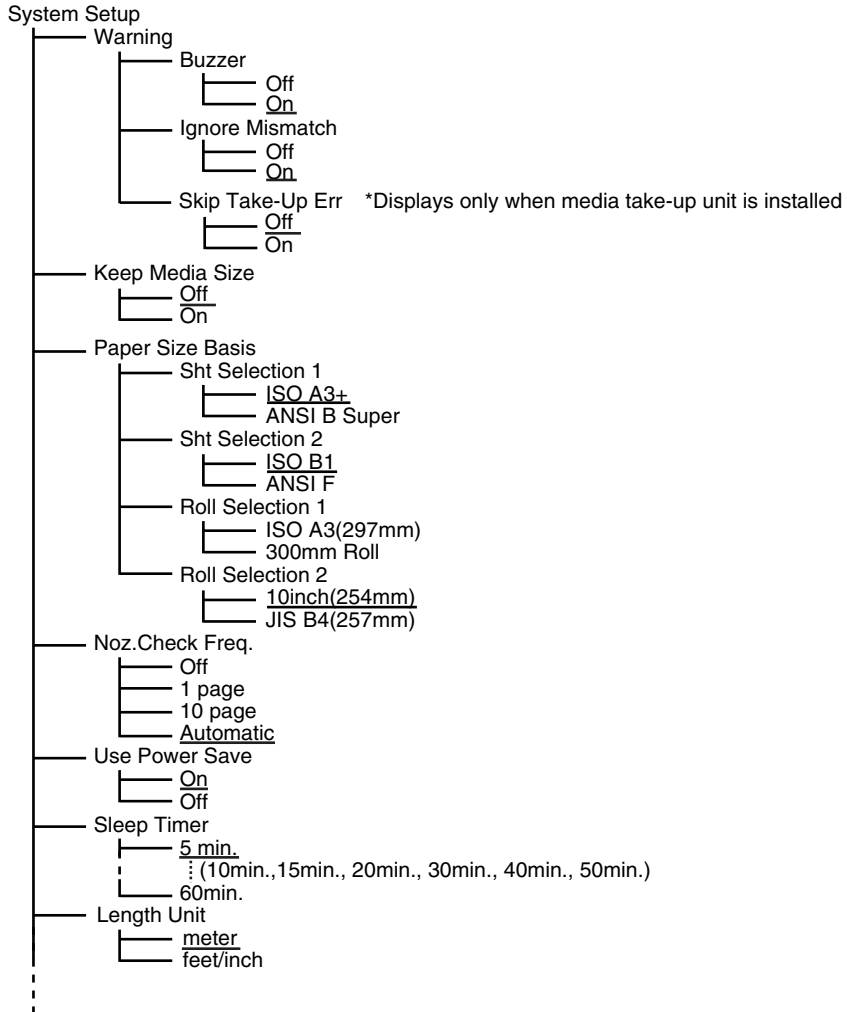

F-1-19

System Setup Menu (2/2)

(System Setup)

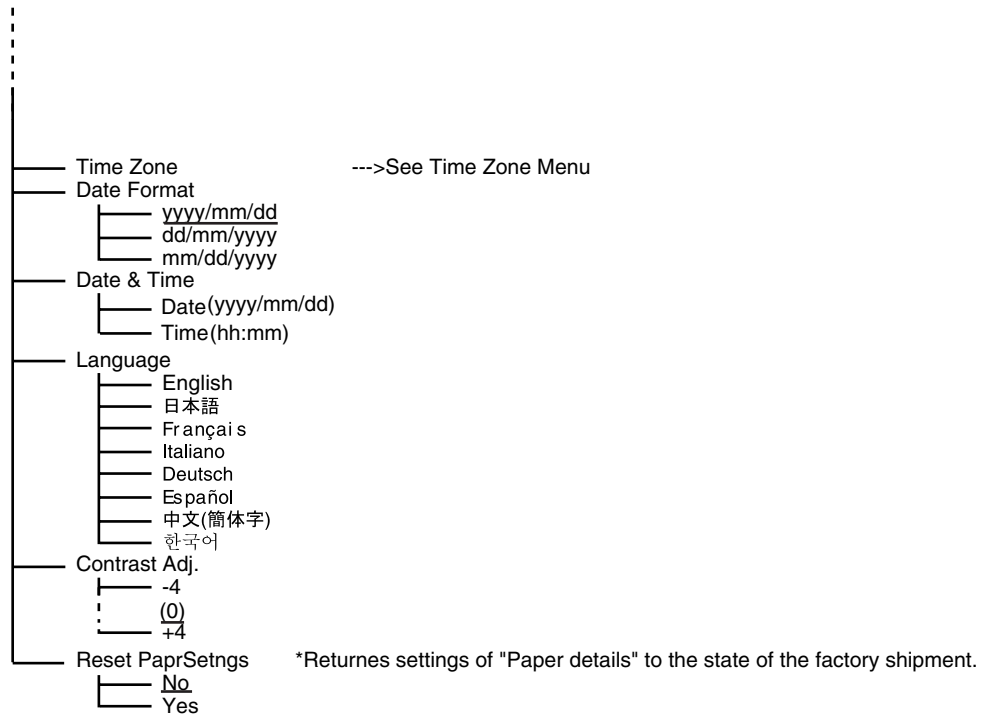

F-1-20

Time Zone setting menu

- Time Zone
- _____ 0 : London (GMT)
 - _____ +1 : Paris , Rome
 - _____ +2 : Athens , Cairo
 - _____ +3 : Moscow
 - _____ +4 : Eerevan , Baku
 - _____ +5 : Islamabad
 - _____ +6 : Dacca
 - _____ +7 : Bangkok
 - _____ +8 : Hong Kong
 - _____ +9 : Tokyo , Seoul
 - _____ +10 : Canbera
 - _____ +11 : NewCaledonia
 - _____ +12 : Wellington
 - _____ -12 : Eniwetok
 - _____ -11 : Midway Is.
 - _____ -10 : Hawaii (AHST)
 - _____ -9 : Alaska (AKST)
 - _____ -8 : Oregon (PST)
 - _____ -7 : Arizona (MST)
 - _____ -6 : Texas (CST)
 - _____ -5 : New York (EST)
 - _____ -4 : Santiago
 - _____ -3 : Buenos Aires
 - _____ -2 :
 - _____ -1 : Cape Verde

Meaning of code address

- GMT : Greenwich Mean Time
- AHST : Alaska-Hawaii Std Time
- AKST : Alaska Standard Time
- PST : Pacific Std Time
- MST : Mountain Standard Time
- CST : Central Std Time
- EST : Eastern Standard Time

F-1-21

Test Print Menu

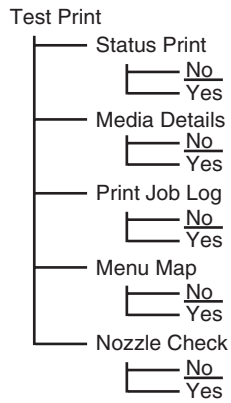

F-1-22

Information

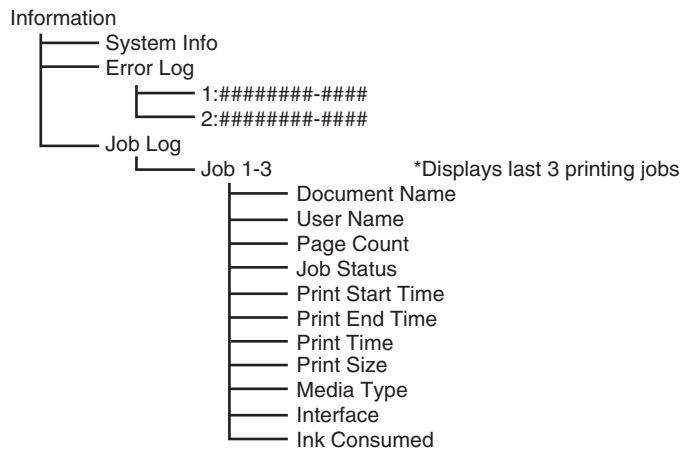

F-1-23

1.7 Safety and Precautions

1.7.1 Safety Precautions

1.7.1.1 Moving Parts

Be careful not to get your hair, clothes, or accessories caught in the moving parts of the printer. These include the carriage unit activated by the carriage motor, carriage belt, ink tube and flexible cable; feed motor-driven feed roller and pinch roller; and purge motor-driven purge unit.

To prevent accidents, the upper cover of the printer is locked during printing so that it does not open. If the upper cover is opened in the online/offline mode, the carriage motor, feed motor, and other driving power supplies are turned off.

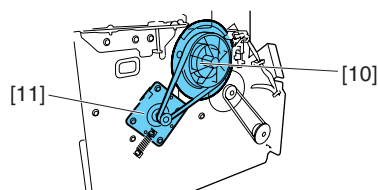
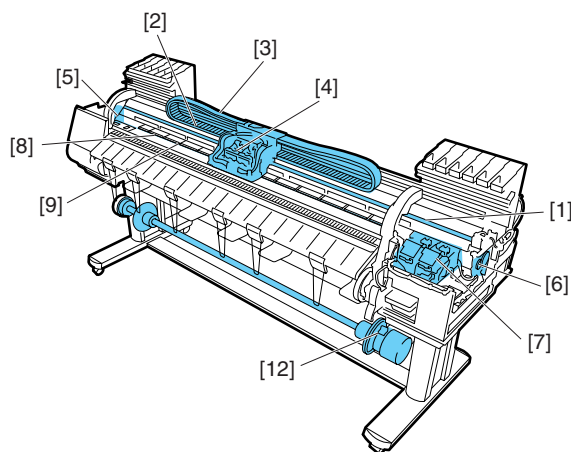
F-1-24
T-1-9

[1]	Carriage belt	[7]	Purge unit
[2]	Ink tube	[8]	Pinch roller
[3]	Flexible cable	[9]	Feed roller
[4]	Carriage unit	[10]	Feed unit
[5]	Carriage motor	[11]	Feed motor
[6]	Lift unit	[12]	Media take-up unit

1.7.1.2 Adhesion of Ink

1. Ink passages

Be careful not to touch the ink passages of the printer or to allow ink to stain the workbench, hands, clothes or the printer under repair.

The ink flows through the ink tank unit, carriage unit, purge unit, maintenance-jet tray, borderless print ink groove, maintenance cartridge and the ink tubes that relay ink to each unit.

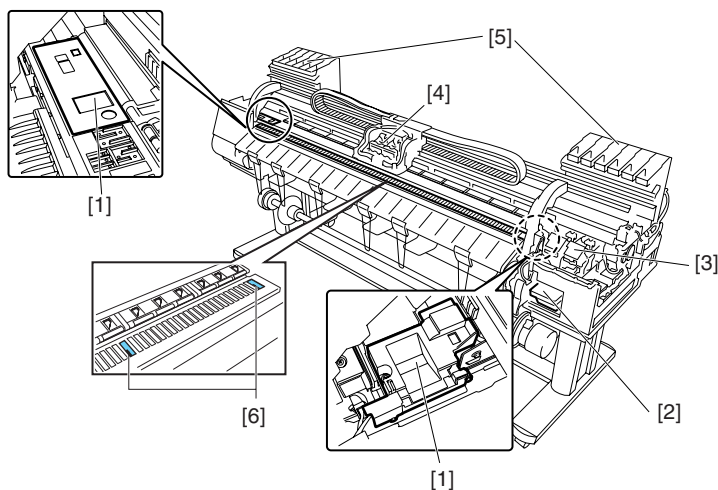
F-1-25
T-1-10

[1]	Maintenance-jet tray	[4]	Carriage unit
[2]	Maintenance cartridge	[5]	Ink tank unit
[3]	Purge unit	[6]	Borderless print ink groove



Although the ink is not harmful to the human body, it contains organic solvents.

Avoid getting the ink in your mouth or eyes.

Flush well with water and see a doctor if contact occurs.

In case of accidental ingestion of a large quantity, call a doctor immediately.

Since this ink contains pigment, stains will not come out of clothing.

2. Ink mist

Since the printhead prints by squirting ink onto the media, a minute amount of ink mist is generated in the printing unit during printing. The ink mist is collected in the printer by the airflow. However, uncollected ink mist may stain the platen unit, carriage unit, main rail unit, external unit, or purge unit. These stains may soil the print media or hands and clothes when servicing the printer, wipe them off carefully with a soft, well-wrung damp cloth.

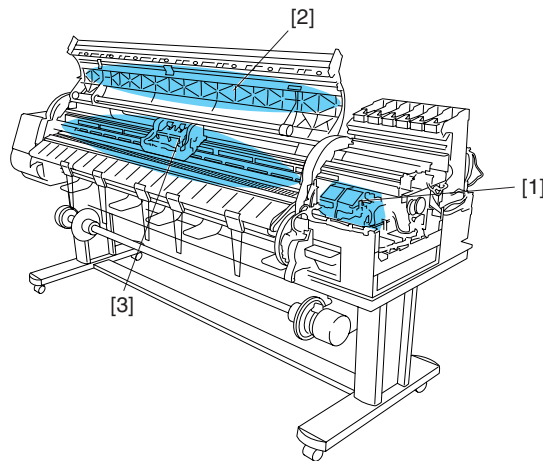

F-1-26
T-1-11

- [1] Purge unit
- [2] Upper cover
- [3] Platen unit/Carriage unit/Main rail unit

1.7.1.3 Electrical Parts

The electrical unit of the printer is activated when connected to the AC power supply. At the rear of the printer are the main controller, power supply, interface connector, and optional media take-up unit connector. The head relay PCB and carriage relay PCB are incorporated in the carriage unit, and the operation panel is located on the upper right cover. When servicing the printer with the cover removed, be extremely careful to avoid electric shock and shorting contacts.

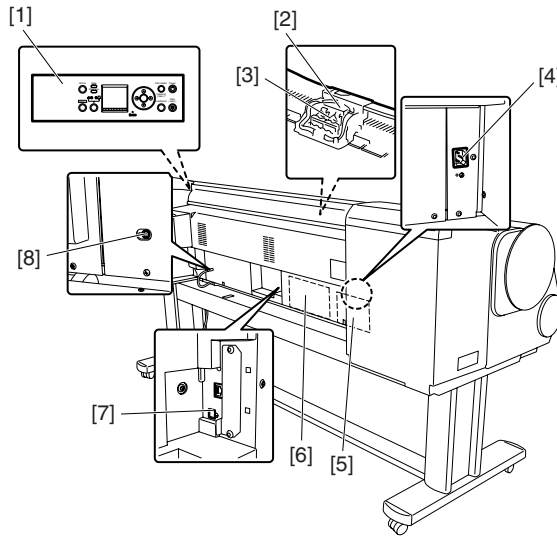

F-1-27
T-1-12

- [1] Operation panel
- [2] Carriage relay PCB
- [3] Head relay PCB
- [4] AC inlet
- [5] Power Supply
- [6] Main controller PCB
- [7] Interface connector
- [8] Media take-up unit connector

1.7.2 Other Precautions

1.7.2.1 Printhead

1. How to Handle the Printhead

Do not open the printhead package until you are ready to install the head. When installing the printhead in the printer, hold the knob [1] and then remove the protective cap 1 [2] and protective cap 2 [3] in that order. Do not reattach the protective cap 2 [3] to the printhead because the cap may damage the nozzles [4]. To prevent the nozzles from getting clogged with foreign matter or dried ink, install the printhead immediately after you remove the protective caps. Also make sure to press down the locking lever of the printhead until you feel a click. In addition, to prevent clogging of the nozzles with foreign matter and improper supply of ink, never touch the nozzles [4] or ink port [6], or wipe it with tissue paper or anything else. Do not touch Electrical contact [5]. Also, never attempt to disassemble/reassemble the printhead or wash it with water.

MEMO:

If the nozzles are clogged or an ink suction problem occurs, white lines can appear on the printout a constant frequency or color dulling can occur. If this problem is not resolved by cleaning operations, replace the printhead with a new one.

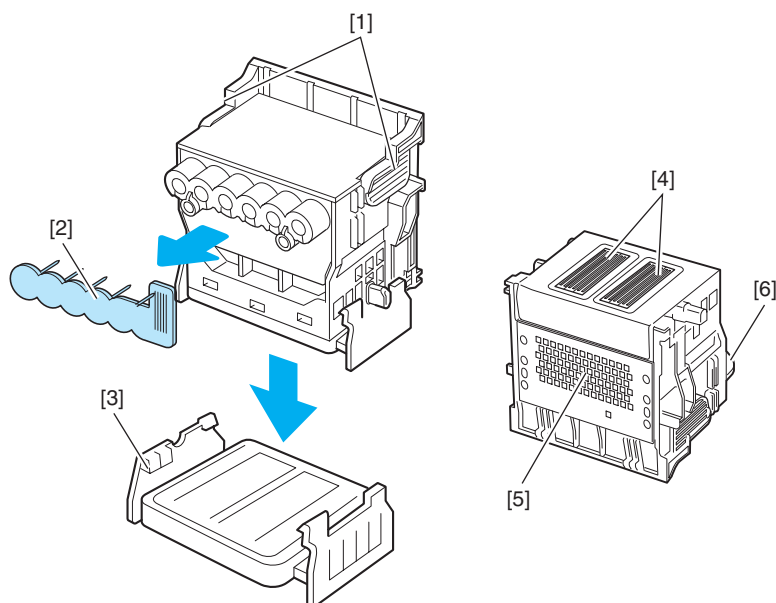

F-1-28

T-1-13

[1]	Knob	[4]	Nozzles
[2]	Protective cap 1	[5]	Electrical contact
[3]	Protective cap 2	[6]	Ink port

2. Capping

The printer will perform the capping operation when printing has ended or during standby due to an error, in order to protect the printhead and avoid ink leakage. If the power cord is accidentally unplugged, turn off the Power button, reconnect the power cord, and then turn on the Power button. Confirm that the printer starts up properly and enters to the "Online" or "Offline" status, and then power off the printer using the Power button.



Improper "capping operation" may cause clogged nozzles due to dried ink or ink leakage from the printhead.

3. When the printer is not used for a long time

Keep the printhead installed in the printer even when it is not used for an extended period of time.



If the printhead is left uninstalled, a printing failure may arise from closed nozzles due to depositing of foreign matter or dried ink when it is reinstalled. Even if the head remains installed, the nozzle may dry out and cause a printing failure if the ink is drained for transport.

4. Conductivity of Ink

The ink used in this printer is electrically conductive. If ink leaks into the mechanical unit, wipe clean with a soft, well-wrung damp cloth. If ink leaks onto electrical units, wipe them completely using tissue paper. If you cannot remove ink completely, replace the electrical units with new ones.



If electrical units are powered with ink leaked onto them, the units may damage. Never connect the power cord when ink has leaked onto the electrical units.

1.7.2.2 Ink tank**1. Unpacking the Ink Tank**

Do not unpack the ink tank until you are ready to install it.

When installing the ink tank, be sure to shake it slowly 7 to 8 times before unpacking it. Otherwise, the ink ingredients may precipitate and degrade the print quality. To prevent foreign matter from entering the ink port, install the unpacked ink tank in the printer immediately.

2. Handling the Ink Tank

To prevent foreign matter from entering the ink flow path and causing ink suction and printing problems, never touch the ink port and contacts of the ink tank.

When you press down the ink tank cover, the needle enters the ink port, allowing ink to flow between the printer and ink tank.

Do not raise or lower the ink tank cover except when replacing the ink tank.

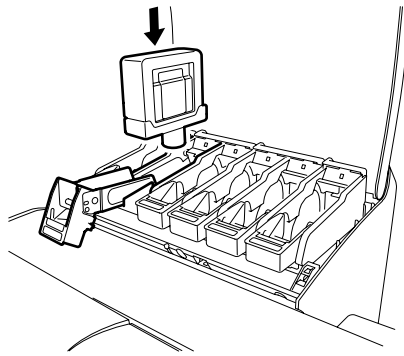

F-1-29

1.7.2.3 Handling the Printer

1. Precautions against Static Electricity

Certain clothing may generate static electricity, causing an electrical charge to build up on your body. Such a charge can damage electrical devices or change their electrical characteristics.

In particular, never touch the printhead contacts[1].

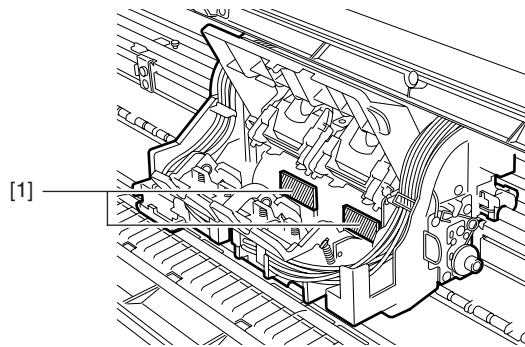

F-1-30

2. Fixing the Carriage

After completion of printing, the carriage is mechanically locked by the lock arm in the purge unit at the same moment the printhead is capped.

Before transporting the printer, secure the carriage at its home position using belt stoppers[1] so that the carriage does not become separated from the lock arm and damage or ink does not leak.

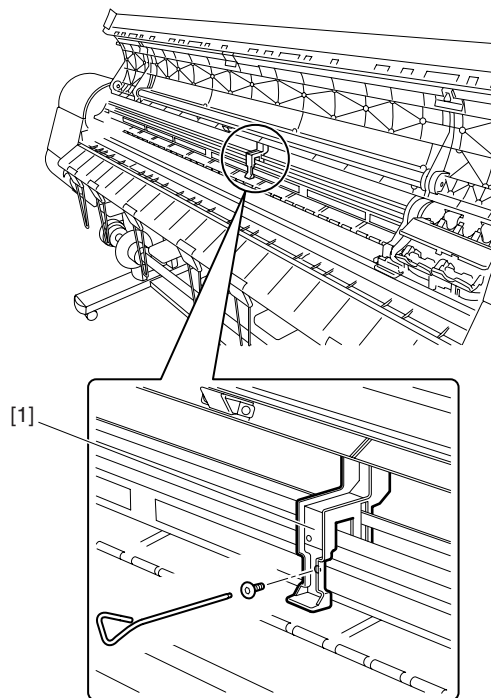

F-1-31

3. Replacing the maintenance cartridge

When the maintenance cartridge detects that tank is full, the "Repl. Maint. C" error appears. In this case the maintenance cartridge must be replaced.

The printer will not operate until the error is cancelled.

Be careful that the waste ink does not splash when you remove the used maintenance cartridge from the printer.

MEMO:

This printer has an EEPROM in the maintenance cartridge and the maintenance cartridge status is controlled by the main controller PCB which reads and writes the content of that EEPROM. Therefore, initializing the counter information will not be needed when the maintenance cartridge is replaced.

4. Refilling the ink

After removing the ink in the printer according to the automatic or manual ink draining procedure to disassemble, reassemble, or transport/ship the printer, refill the ink as soon as possible upon completion of those tasks.

If the ink remaining in the printer after the removal has dried up, the ink deposits on the surfaces of the components may cause damage or abnormal operation.

1.7.3 Precautions When Servicing Printer

1.7.3.1 Notes on the Data Stored in the Printer

This printer counts the print length, number of ink tank replacements, carriage driving time, number of cleaning operations, number of cutter operations, and so on and stores them in the main controller's EEPROM as a COUNTER in Service mode.

COUNTER provides important information about the printer usage status.

You can check this information by printing it in the service mode or displaying it on the display.

Following the precautions below when servicing the printer.

a) Repairing/replacing the PCB

When replacing the main controller, follow the specified replacement procedure.

b) After replacing the carriage unit

The information about the carriage driving time arises in the carriage unit. After replacing the carriage unit, select INITIALIZE > CARRIAGE in the service mode to initialize the information about the carriage driving time.

c) After replacing the purge unit

The information about the number of cleanings arises in the purge unit. After replacing the purge unit, select INITIALIZE > PURGE in the service mode to initialize the information about the number of cleanings.

Reference:

For the main controller replacement procedure, see Disassembly/Reassembly > Points to Note on Disassembly and Reassembly > PCBs.



You cannot check the counter information once it is initialized. Be careful not to initialize the counter information before checking it. You cannot modify the counter information from the operation panel.

1.7.3.2 Confirming the Firmware Version

Firmware has been downloaded to the main controller.

When you have replaced the main controller, check that the firmware is the latest version. If not, update it to the latest version.

Reference:

For how to update the main controller, refer to TROUBLESHOOTING > Version Up.

1.7.3.3 Precautions Against Static Electricity

Certain clothing may generate static electricity, causing an electrical charge to build up on your body. Such a charge can damage electrical devices. To prevent this, discharge any static buildup by touching a grounded metal fitting before you start disassembling the printer.

1.7.3.4 Precautions for Disassembly/Reassembly

The precautions for disassembly/Reassembly are described in DISASSEMBLY/REASSEMBLY

1.7.3.5 Self-diagnostic feature

The printer has a diagnostic feature which analyzes printer problems (which may occur).

The diagnostic results will be displayed on the display and indicated by a light.

For detailed information, see ERROR CODE.

1.7.3.6 Disposing of the Lithium Battery

The main controller PCB mounted in the printer has one lithium battery to back up various data.



Risk of explosion if battery is replaced by an incorrect type. Dispose of used batteries according to the instructions.

Achtung:

Die Lithiumbatterie darf nur durch das Originalersatzteil (Parts Katalog) ersetzt werden; ansonsten besteht Brand-/Explosionsgefahr.

Lithiumbatterien niemals aufladen, demontieren oder durch Verbrennen entsorgen;

bei der Entsorgung die örtlichen Entsorgungsvorschriften beachten (Schadstoffe; Sondermüll).

Chapter 2 TECHNICAL REFERENCE

Contents

2.1 Basic Operation Outline.....	2-1
2.1.1 Printer Diagram.....	2-1
2.1.2 Print Driving.....	2-1
2.2 Firmware.....	2-1
2.2.1 Operation Sequence at Power-on.....	2-1
2.2.2 Operation Sequence at Power-off.....	2-2
2.2.3 Print Control.....	2-3
2.2.4 Print Position Adjustment Function.....	2-4
2.2.5 Head Management.....	2-4
2.2.6 Printhead Overheating Protection Control.....	2-4
2.2.7 Pause between Pages.....	2-4
2.2.8 White Raster Skip.....	2-4
2.2.9 Sleep mode.....	2-4
2.3 Printer Mechanical System.....	2-5
2.3.1 Outline.....	2-5
2.3.1.1 Outline.....	2-5
2.3.2 Ink Passage.....	2-5
2.3.2.1 Ink Passage.....	2-5
2.3.2.1.1 Overview of Ink Passage.....	2-5
2.3.2.2 Ink Tank Unit.....	2-6
2.3.2.2.1 Structure of Ink Tank Unit.....	2-6
2.3.2.3 Carriage Unit.....	2-8
2.3.2.3.1 Functions of Carriage unit.....	2-8
2.3.2.3.2 Structure of Carriage Unit.....	2-8
2.3.2.4 Printhead.....	2-10
2.3.2.4.1 Structure of Printhead.....	2-10
2.3.2.5 Purge Unit.....	2-11
2.3.2.5.1 Functions of Purge Unit.....	2-11
2.3.2.5.2 Structure of Purge Unit.....	2-12
2.3.2.6 Maintenance Cartridge.....	2-14
2.3.2.6.1 Maintenance cartridge.....	2-14
2.3.2.7 Air Flow.....	2-14
2.3.2.7.1 Air flow.....	2-14
2.3.3 Paper Path.....	2-14
2.3.3.1 Outline.....	2-14
2.3.3.1.1 Overview of Paper Path.....	2-14
2.3.3.2 Paper Path.....	2-16
2.3.3.2.1 Structure of Feed Roller Unit.....	2-16
2.3.3.3 Cutter Unit.....	2-16
2.3.3.3.1 Structure of the cutter unit.....	2-16
2.4 Printer Electrical System.....	2-16
2.4.1 Outline.....	2-16
2.4.1.1 Overview.....	2-16
2.4.2 Main Controller.....	2-17
2.4.2.1 Main controller components.....	2-17
2.4.3 Carriage Relay PCB.....	2-19
2.4.3.1 Carriage relay PCB components.....	2-19
2.4.4 Head Relay PCB.....	2-19
2.4.4.1 Head relay PCB components.....	2-19
2.4.5 Motor Driver.....	2-19
2.4.5.1 Media take-up unit components.....	2-19
2.4.6 Maintenance Cartridge Relay PCB.....	2-20
2.4.6.1 Maintenance cartridge relay PCB components.....	2-20

2.4.7 Power Supply	2-20
2.4.7.1 Power supply block diagram.....	2-20
2.5 Detection Functions with Sensors	2-20
2.5.1 Cover system.....	2-20
2.5.2 Ink passage system.....	2-21
2.5.3 Carriage system.....	2-23
2.5.4 Paper path system	2-24
2.5.5 Humidity sensor	2-24
2.5.6 Media take-up Unit	2-25

2.1 Basic Operation Outline

2.1.1 Printer Diagram

A printer diagram is shown below.

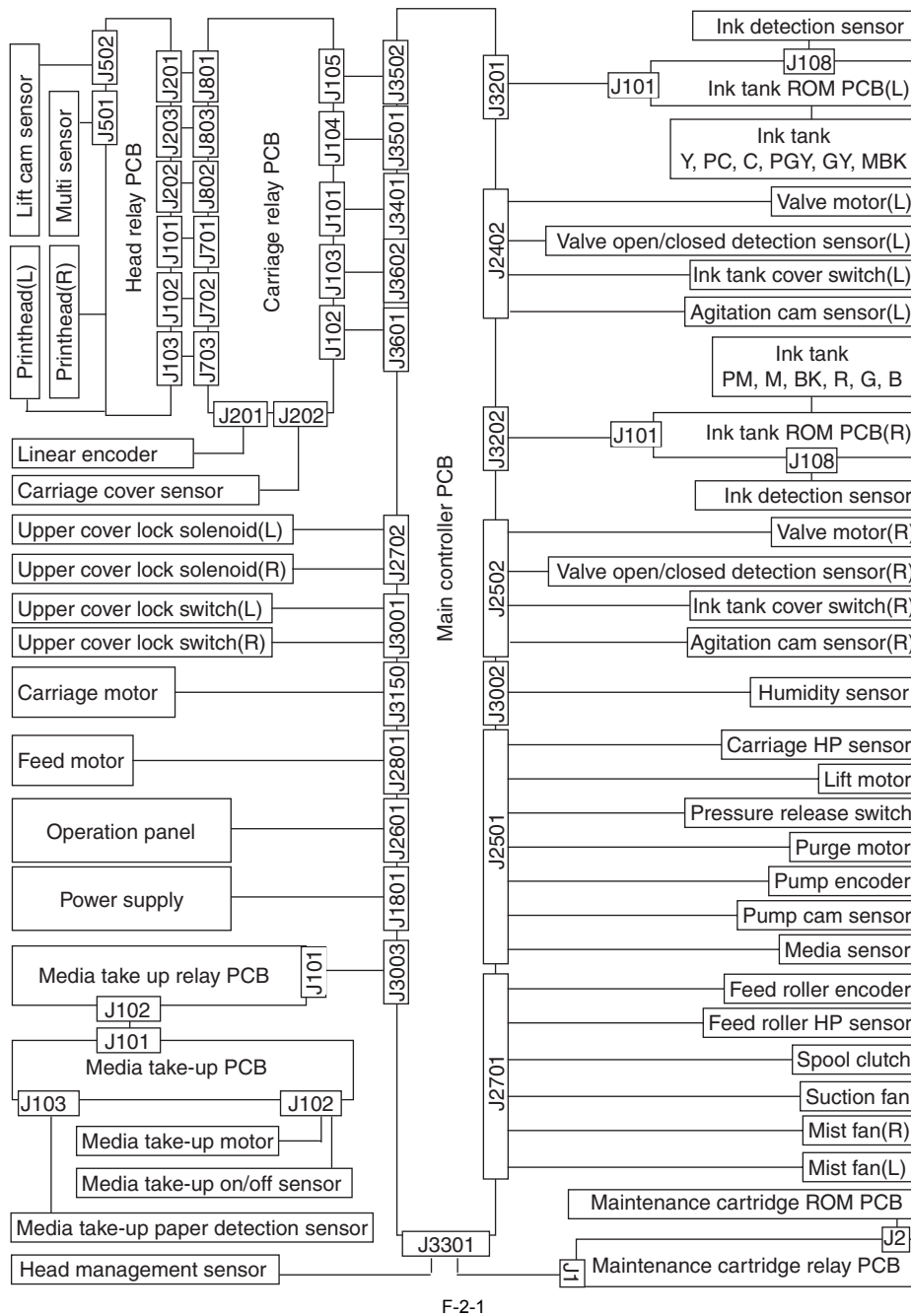

2.1.2 Print Driving

During printing, print signals and control signals are issued to the printhead via the carriage relay PCB and Head relay PCB in order to discharge ink from the nozzles.

On a printhead, six arrays of nozzles are provided in six arrays in a staggered pattern.

This printer uses a pair of printheads.

(The Y, PC, C, PGy, Gy, MBk, PM, M, Bk, R, G, B nozzles are mounted in this order from the left.)

Even-numbered nozzle data and odd-numbered nozzle data -- which are print signals -- are sent to each nozzle array in sync with the data sending clock and data latch pulse timings.

Drive control signals include a Heat Enable signal and a Sub Heat Enable signal. The Heat Enable signal is used to discharge ink from nozzles. The Sub Heat Enable signal is used to raise the printhead temperature to a suitable value to maintain the ink discharge amount constant.

2.2 Firmware

2.2.1 Operation Sequence at Power-on

The sequence of printer operations, from power-on to transition to online mode, is flowcharted below. The printer takes less than 1 minute to initialize itself(*).

* Excluding the times spent supplying inks and cleaning the printhead after leaving the printer for extended periods of time

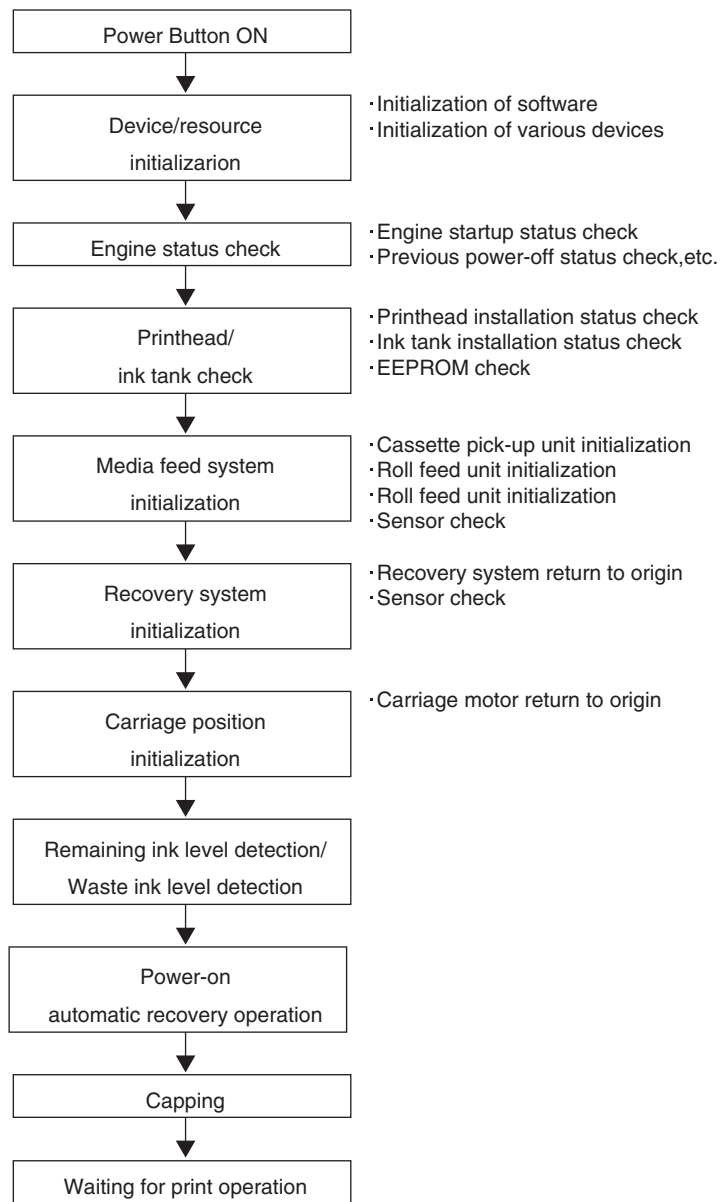

F-2-2

2.2.2 Operation Sequence at Power-off

Turning off the power switch cuts off the drive voltage supply, launching a firmware power-off sequence as shown below.



If the power cord is disconnected from the wall outlet or the upper cover or any other cover is opened, the printer cancels the ongoing operation and shuts down immediately. Since printhead capping may or may not have been carried out properly, reconnect the power cord to the wall outlet and turn on the power switch. Making sure that the printer has entered online mode, turn off the power switch.

1. Power-off sequence

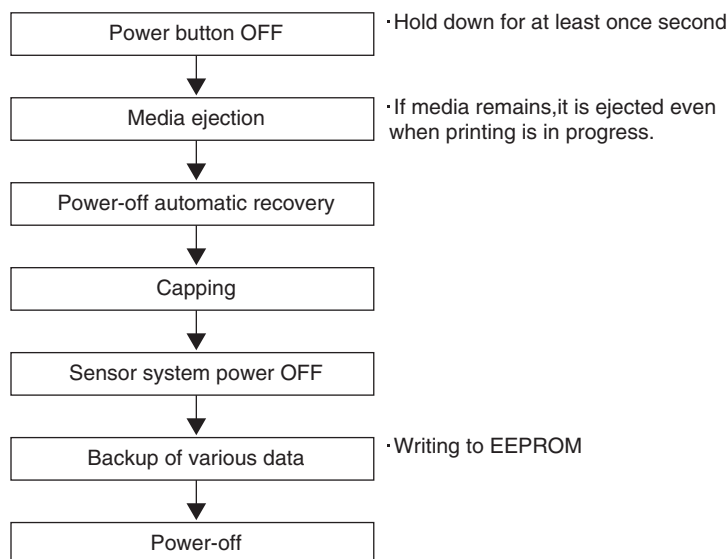

F-2-3

2.2.3 Print Control

1. Print modes

Print methods, such as carriage and paper feed operation, are varied according to the media type, print quality, kind of print data and so forth to achieve high-quality high-speed print free from blurring and uneven density.

Because each color prints in up to 16 passes according to the print quality requirement for a print mode, uneven density problems caused by variations in the rate of discharge among different nozzles are eliminated. Deferred print timings do not allow a new ink to overprint the preceding ink until the preceding ink has virtually fixed, thereby reducing the chances of blurred printing.

Different operations take place even in the same print mode according to the paper setting of the print driver.

a) Draft mode

Imaging data is thinned out to print in one or two passes per band (equivalent of the length of a nozzle).

Configure the print driver for print quality Draft to enable draft mode

b) Standard mode

Imaging data prints in one to six (one, two, four or six) passes per band (equivalent of the length of a nozzle).

Configure the print driver for print quality setting Standard to enable standard mode.

c) High quality mode

Imaging data prints in two, four or eight passes per band.

Configure the print driver for print quality High to enable high quality mode.

d) Highest quality mode

Imaging data prints in eight or 16 passes per band.

Configure the print driver for print quality Highest to enable highest quality mode.

Print Mode List

T-2-1

Media Type	Print Priority	Print Quality	Processing resolution (dpi)	Print resolution (dpi)	Print pass	Printing direction (*1)
Plain Paper Plain Paper(High Quality) Plain Paper(High Grade)	Image	draft	300	1200x1200	2	Bi-directional
		standard	300	1200x1200	4	Bi-directional
		High	600	2400x1200	8	Bi-directional
	Line drawing /Text	draft	600	1200x1200	2	Bi-directional
		standard	600	1200x1200	4	Bi-directional
	Office document	standard	600	1200x1200	4	Bi-directional
Recycled Coated Paper Coated Paper Heavyweight Coated Paper Extra Heavyweight Coated Paper	Image	standard	300	1200x1200	4	Bi-directional
		High	600	2400x1200	8	Bi-directional
		Highest	600	2400x1200	12	Bi-directional

Media Type	Print Priority	Print Quality	Processing resolution (dpi)	Print resolution (dpi)	Print pass	Printing direction (*1)	
Premium Matte Paper Glossy Photo Paper Semi-Glossy Photo Paper Heavyweight Glossy Photo Paper Heavyweight SemiGlos Photo Paper Synthetic Paper Adhesive Synthetic Paper Backlit Film Backprint Film Flame-Resistant Cloth Fabric Banner Thin Fabric Banner Proofing Paper Fine Art Photo Fine Art Heavyweight Photo Fine Art Textured Fine Art Watercolor Fine Art Block Print Canvas Matte Canvas Semi-Glossy Japanese Paper Washi	Image	standard	600	1200x1200	6	Bi-directional	
		High	600	2400x1200	8	Bi-directional	
		Highest	600	2400x1200	16	Bi-directional	
	Colored Coated Paper	Image	standard	300	1200x1200	4	Bi-directional
			High	600	2400x1200	8	Bi-directional
	CAD Tracing Paper CAD Translucent Matte Film CAD Clear Film	Line drawing /Text	draft	600	1200x1200	2	Bi-directional
			standard	600	1200x1200	4	Bi-directional
			High	600	2400x1200	8	Bi-directional

*1 Uni-directional can be selected optionally from the printer driver.

2.2.4 Print Position Adjustment Function

This printer supports a print position adjust the vertical and horizontal print position and the bidirectional print position of the print head mounted on the carriage and the feedrate.

Print position adjustment work in two modes: automatic adjustment, in which print position adjustment patterns printed are detected by a multi sensor attached to the lower left part of the carriage, and manual adjustment, in which print position adjustment patterns that are slightly modified from one another are printed, so that visually verified adjustment values can be set from the operation panel.

To make print position adjustment, A3-or-larger-sized roll media or cut media are needed.

2.2.5 Head Management

This printer supports a nozzle check function to spot non-discharging nozzles in the printhead.

When the printer detects a non-discharging nozzle, it starts cleaning the printhead automatically to correct its discharge failure. If cleaning does not work, the printer backs up the non-discharging nozzle with an alternative nozzle automatically to ensure unfailling print performance.

Detection timings (automatic):

Power-on, carriage cover open detection, print start (check timing variable by selecting Nozzle Check from the system menu).

2.2.6 Printhead Overheating Protection Control

When an abnormal temperature rise in the printhead is detected, overheating protection control launches.

Overheating could occur in the printhead after a spell of print operations without the nozzles being filled with inks.

Overheating protection control is implemented on the basis of the temperature detected by the head temperature sensor for each nozzle. When an abnormal temperature is detected in any nozzle train, overheating protection control is exerted at one of two levels according to that temperature.

Protection level 1:

If the head temperature sensor (DI sensor) detects a temperature higher than the protection temperature, it halts the carriage temporarily at the scan end position in the direction of travel according to the carriage scan status.

Printing resumes when the printhead radiates naturally to cool down to below a predetermined temperature or when 30 seconds or longer have elapsed since the detection of the temperature higher than the protection temperature.

Protection level 2:

If the head temperature sensor (DI sensor) detects a temperature higher than the abnormal temperature, the printer shuts down the print operation immediately, moving the carriage to the home position for capping, with an error indication on the display.

2.2.7 Pause between Pages

An inter-page function is available to prevent ink rubbing, which keeps paper just printed hanging above the platen and waiting for a predetermined period of time before delivery.

The wait time is user-programmable from the print driver. This feature is particularly useful on paper that takes time to dry after printing, such as films.

2.2.8 White Raster Skip

This printer supports a white raster skip function to bypass carriage scanning in a consecutive sequence of voids in print data for added throughput.

2.2.9 Sleep mode

The printer has sleep mode to save on its standby power requirement.

The printer transitions to sleep mode automatically when it has been left idle or no print data has been received for a predetermined period of time while the printer is online or offline.

The printer exits sleep mode when any operation panel key is activated or print data is received from the host computer.

The time to transition to sleep mode is variable from the operation panel (Default: 5minutes).

2.3 Printer Mechanical System

2.3.1 Outline

2.3.1.1 Outline

The printer mechanism is broken down into two broad sections: ink passage and paper passage.

The ink passage consists primarily of carriage unit[2] that houses ink tanks[1] and a printhead, purge unit[3] and maintenance cartridge[4], and supplies, circulates, sucks and otherwise handles inks.

The paper passage consists of mechanical components, such as a paper feed unit[5], and is designed to feed, convey and deliver paper in two ways.

A summary description of each mechanical component of the printer is given below.

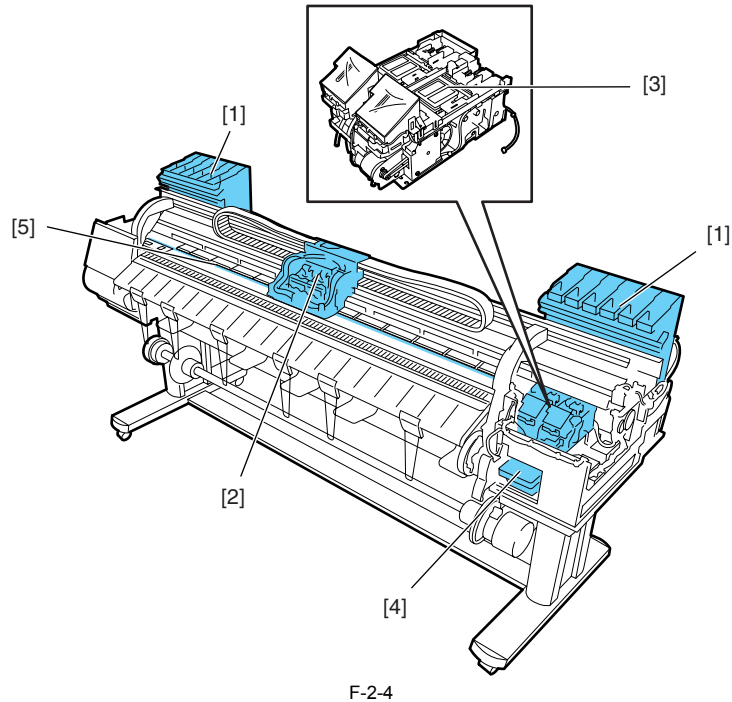

2.3.2 Ink Passage

2.3.2.1 Ink Passage

2.3.2.1.1 Overview of Ink Passage

The ink passage comprises ink tanks, a printhead, caps, a maintenance jet tray, a maintenance cartridge, ink tubes interconnecting the mechanical components of the printer, and a suction pump that is driven to suck inks. It supplies, circulates, sucks and otherwise handles inks.

0012-6328

The ink passage (per color) is schematically shown below, along with the ink flow.

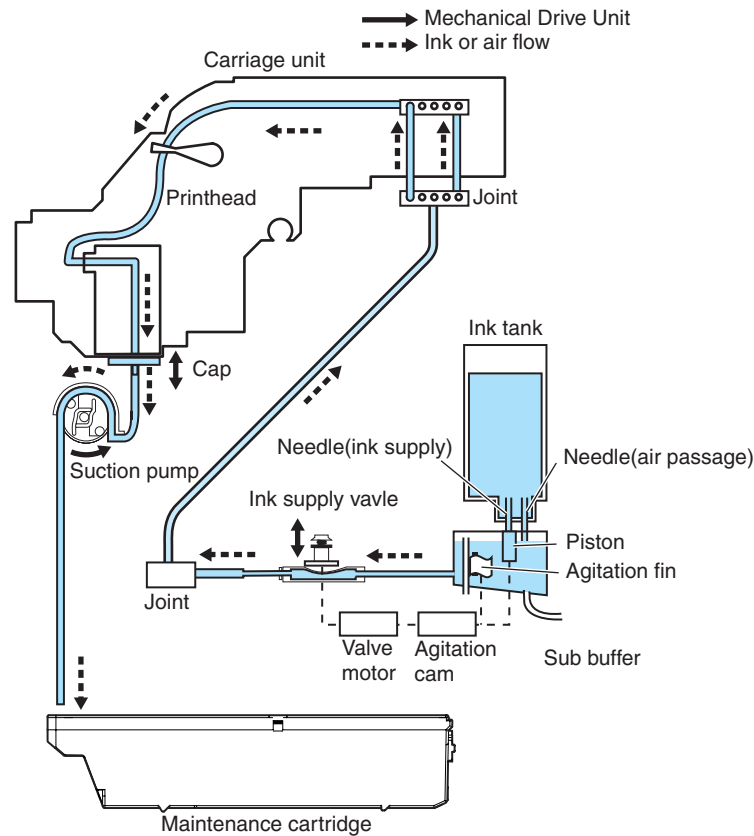

a) Supplying inks from the ink tanks to the ink supply valve assembly

The ink tanks each contain an ink to feed the printhead.

Head differences allow the inks to flow from the ink tanks to the sub tanks first, then to the ink supply valves.

Air is discharged through the air passage of the sub tanks to keep the internal pressure of the ink tanks constant.

b) Supplying inks from the ink supply valves to the printhead

The ink stored in an ink tank flows to the printhead when the suction pipe is driven with the ink supply valve opened and the head capped.

c) Supplying inks while printing

The ink supply valves are kept open while printing, so that inks are constantly feeding to the printhead under the negative pressure of the nozzle assembly caused by discharging inks.

Further, waste inks sucked in a cleaning operation and inks from the maintenance jet tray flow into the maintenance cartridge.



Opening all the ink passages (by opening both the ink supply valve and the printhead fixer lever with an ink tank yet to be installed) while an ink tube is filled with an ink could cause the ink in the ink tube to flow backward due to a head difference, leaking through the hollow needle in the ink tank.

As a precaution, never open all the ink passages at the same time while the ink tubes are filled with inks.

d) Ink agitating

Ink will be agitated to prevent the element of the pigment ink from subsiding in the ink tank and the sub-tank.

The drive of valve motor is transmitted to the agitation cam, the agitation fin in a sub-tank rotates and ink in a sub-tank will be agitated. In addition, ink flows backward by moving the piston under the needle (ink supply) up and down in the ink tank, and ink in the ink tank will be agitated.

2.3.2.2 Ink Tank Unit

2.3.2.2.1 Structure of Ink Tank Unit

0012-6329

a) Ink tanks

The ink level in each ink tank is memorized in EEPROM attached to the tank and is detected as a dot count on the basis of the EEPROM information.

When an electrode attached to a hollow needle detects no continuity, it displays a message reporting that the ink tank is nearly empty.

If the dot count reaches a predesigned value in this state, an ink out condition is assumed.

b) Ink port

Depressing the ink tank fixer lever on the printer would cause a hollow needle to pierce the ink tank port sealed by a rubber plug, linking the ink passage of the ink to the printer.

c) Air passage

Depressing the ink tank fixer lever on the printer would cause an open hollow needle to pierce the air passage sealed by a rubber plug releasing the internal pressure of the ink tank to keep it constant.

d) Notches for preventing incorrect installation

Ink tanks are furnished with a notch for preventing incorrect installation.

If the installation of an ink tank in incorrect position is attempted, the notch would interfere with it, preventing its installation.

The ink tank fixer lever won't lower without the ink tank fully inserted to reach the mounting position, so the ink cannot be supplied.

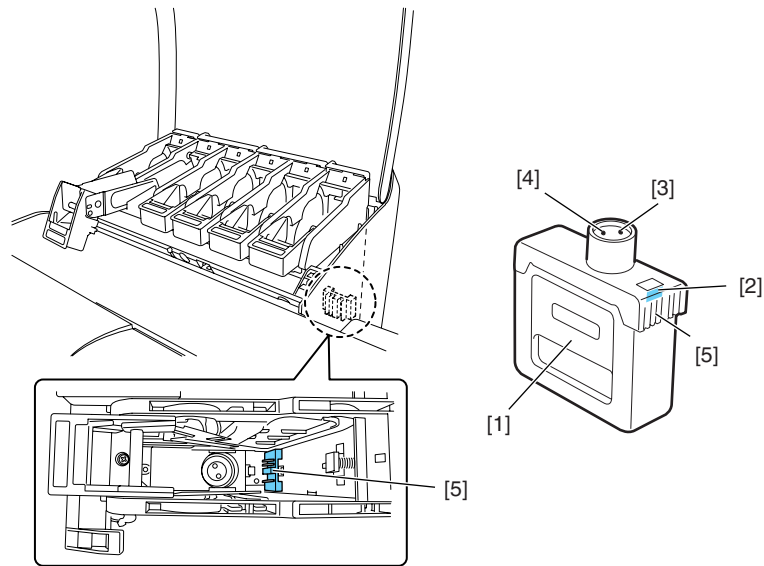

F-2-6
T-2-2

- | | |
|---|-----------------|
| [1] Ink tank | [2] EEPROM |
| [3] Ink port | [4] Air passage |
| [5] Notch for preventing incorrect installation | |

e) Subtank

The subtank installed under each ink tank complements the work of the ink tank, agitating the ink in the tank.

If the ink tank runs out of the ink while printing, the ink stored in the subtank is available, allowing the ink tank to be replaced without having to stop printing.

f) Ink supply valves

Ink tank supply valves are located halfway between the ink tanks and the ink tubes. These valves prevent the leakage of inks that might otherwise be caused by the opening of the ink tubes on the side of the ink tanks during their replacement.

The ink supply valves are caused to open and close by the valve open/close mechanism that is activated by driving the valve motors.

The ink tank unit consists of tank bases each organized into one group of six colors, and six-color ink tubes.

The color-specific ink supply valves are linked with the valve cams so they will open and close at the same time for all colors.

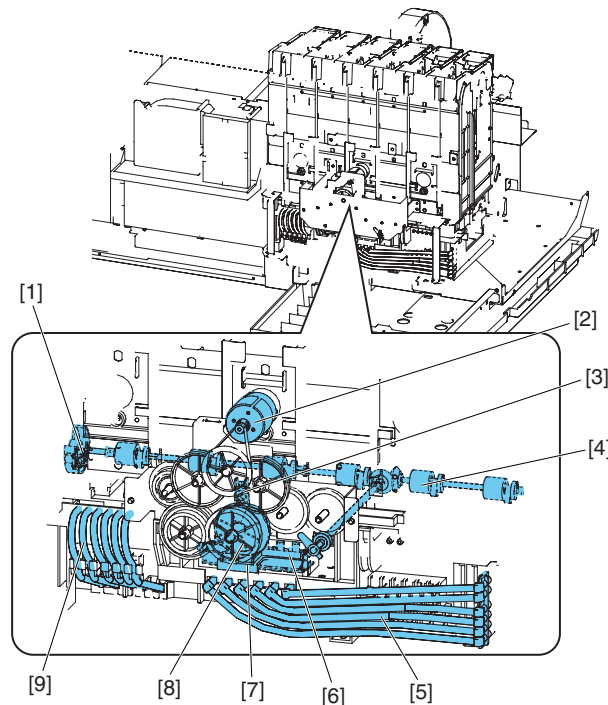

F-2-7
T-2-3

- | | |
|--|----------------------|
| [1] Agitation cam sensor | [2] Valve motor |
| [3] Valve open/closed detection sensor | [4] Agitation cam |
| [5] Ink tube | [6] Ink supply valve |
| [7] Link | [8] Valve cam |
| [9] Ink discharge tube | |

2.3.2.3 Carriage Unit

2.3.2.3.1 Functions of Carriage unit

0012-6330

a) Printhead mounting function

The carriage, which fixes the printhead in position mechanically, is connected to the contact of the head relay PCB.

b) Control function

The carriage carries a carriage relay PCB, which relays drive signals from the main controller PCB, a head relay PCB, which relay printhead drive signals to printhead, a linear encoder, which generates print timing signals, and a multi sensor, which detects the width of paper and skews in it, adjusts its registration and head height.

The carriage relay PCB is connected to the main controller PCB by a flexible cable.

c) Carriage drive function

The carriage is caused to reciprocate level on the platen by means of the carriage belt that is driven by the power imparted from the carriage motor.

d) Printhead maintenance function

This printer performs cleaning operations, such as wiping the printhead and sucking inks, with the carriage halted at its home position.

e) Nozzle check function

This printer carries out an ink discharge operation with the carriage halted at the head management sensor, locating a non-discharging nozzle in the printhead.

f) Carriage height adjustment function

If the separation between the face of the printhead and the paper (carriage height) is varied as a result of differing paper thicknesses, cockled or curled paper or other problems, the printer is liable to mist generation as the carriage height increases or to head rubbing as the carriage height decreases.

To maintain an acceptable carriage height, the lift motor is driven according to the selected paper type, feeding method, print conditions (borderless printing/prioritized picture quality), environmental condition (temperature/humidity) and multi sensor measurements to automatically adjust the separation between the face of the printhead and the paper

The table below shows the relation between the form kind and the height of the head.

T-2-4

Height of printhead (mm)	Media type	Remarks
1.4 (Lowest)	Photopaper, Synthetic paper, Film, Plain paper(Line drawing)	Capping position
1.8 (Low)	Coated paper(Line drawing)	
2.0 (Standard)	Plain paper, Coated paper, Fabric banner	
2.2 (High)	Premium matte paper, Fine art(watercolor,block print)	
2.6 (Highest)	Canvas	

g) Paper leading edge detection function/paper width detection function/skew detection function

The multi sensor attached to the lower left part of the carriage detects the leading edge and width of paper feeding on the platen and skews in it.

h) Automatic printhead position adjustment function

The multi sensor attached to the lower left part of the carriage reads an adjustment pattern printed on a form and adjusts the print timing of each printhead automatically.

i) Remaining roll media detection function

The printer prints a bar code on roll media upon delivery. The multi sensor attached to the lower left part of the carriage indicates the remaining volume of roll media.

j) Internal unit temperature sensor

A thermistor installed on the head relay PCB detects the internal unit temperature near the printhead.

2.3.2.3.2 Structure of Carriage Unit

0012-6332

a) Printhead mount

The printhead is secured to the carriage by the printhead fixer cover and the printhead fixer lever.

When the printhead is secured to the carriage, the signal contact of the head relay PCB is pressed against that of the printhead to convey print signals. Further, the ink passage from the ink tanks is connected to the printhead via the ink tubes.

b) Ink port

Ink is supplied to the printhead via an ink tube, which runs between the tube guides via joints to reach the carriage and follows up its motion.

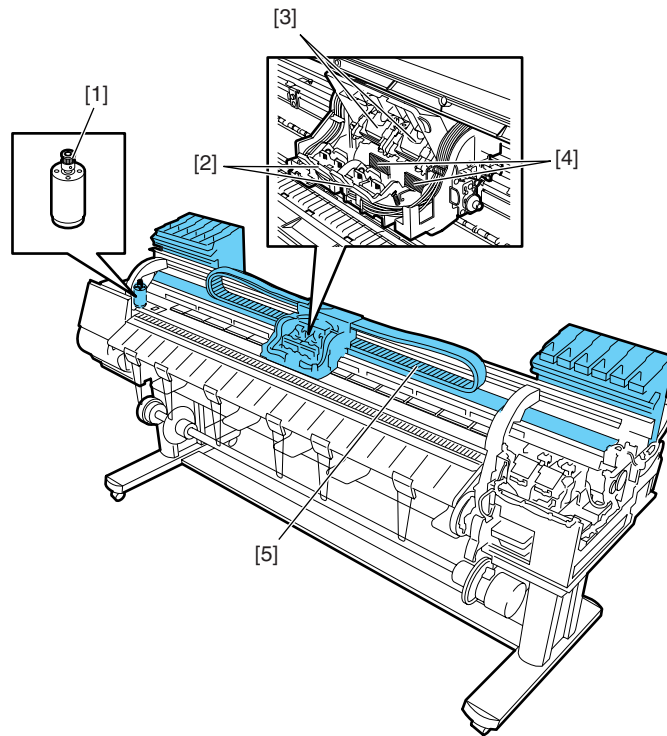

F-2-8
T-2-5

- [1] Carriage motor
- [2] Printhead fixer lever
- [3] Printhead fixer cover
- [4] Electrical contact
- [5] Ink tube

c) Controller

The Carriage relay PCB is connected to the head relay PCB by means of a short flexible cable. The flexible cable between the main controller and the carriage relay PCB follows up the motion of the carriage together with the tube guide. A photocoupler encoder mounted in the lower part of the back of the carriage detects a linear scale reading as the carriage moves.

d) Carriage drive

Mechanical misregistrations in the vertical/horizontal and bidirectional print positions of the printhead mounted can be corrected by selecting Adjust Printer from the main menu to shift the print timing.

A DC-operated carriage motor drives the carriage reciprocally on the platen by way of the carriage belt.

The carriage home position, or the capping position, is detected by the sensor flag on the right side of the carriage and the photointerrupter-based carriage HP sensor on the right side of the printer. When the linear scale position is set as a reference home position for use in subsequent position control operations, the carriage motor is driven by a control signal generated from the main controller PCB.

e) Printhead maintenance unit

This printer cleans the printhead with the carriage halted at its home position.

Wiping takes through the rotation of the motor.

Wiper blades mounted on the carriage wipe the printhead while the carriage is halted at its home position.

Wet wiping is carried out for added wiping removal performance, whereby the wiper blades are moistened with glycerin as they are pressed against an absorber impregnated with glycerin.

Maintenance jet ejection is carried out on the cap, at the maintenance jet tray, borderless printing ink tray and on the paper surface.

A suction operation is carried out by a suction cap in the purge unit.

f) Carriage height adjustment unit

The head height is adjusted with the carriage halted at its home position.

The lift motor is driven to rotate the lift shaft within the carriage, in sync with which the lift cams on both sides of the carriage move the head holder up and down, thereby varying the separation between the face of the printhead and the paper.

The printhead height is detected from the lift cam sensor within the carriage and the distance of rotation of the lift motor.

g) Multi sensor

The multi sensor attached to the lower left part of the carriage consists of four LEDs (red, blue, green, infrared) and two light-receiving sensors to detect the leading edges and width of paper and skews in it, and to adjust its registration and head height.

The multi sensor standard has a white plate attached to it, so that a reference value can be calculated during carriage height measurement by measuring the intensity of light reflected upon the white plate.

(Service mode: SERVICE MODE>ADJUST>GAP CALIB)

h) Rail cleaner

The shaft cleaner located in the right rear of the carriage helps keep the main rail clean.

i) Internal unit temperature sensor

One thermistor is installed on the head relay PCB on the back of the head holder to detect the internal unit temperature.

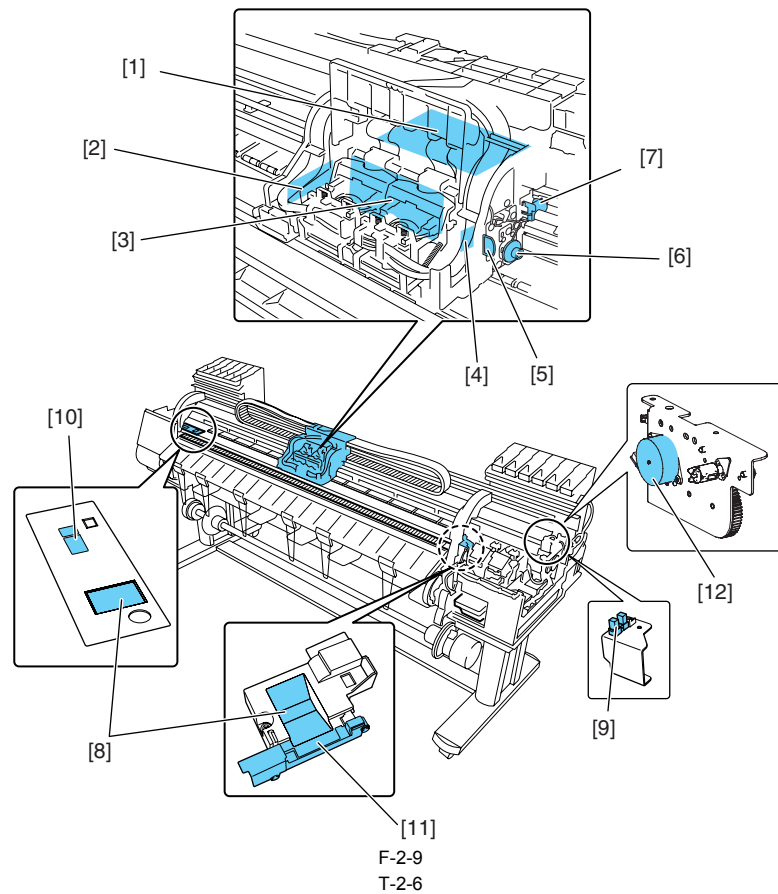

- | | | | |
|-----|--------------------|------|-----------------------------|
| [1] | Carriage relay PCB | [7] | Shaft cleaner |
| [2] | Multi sensor | [8] | Maintenance jet tray |
| [3] | Head relay PCB | [9] | Carriage HP sensor |
| [4] | Lift cam sensor | [10] | Multisensor reference |
| [5] | Sensor flag | [11] | Head management sensor unit |
| [6] | Lift cam | [12] | Lift motor |
- F-2-9
T-2-6

2.3.2.4 Printhead

2.3.2.4.1 Structure of Printhead

Each printhead is an integrated assembly of six trains of nozzles. Capable of controlling each nozzle individually, each printhead implements discharge control for six colors by itself. 0013-8015

a) Nozzle arrangement

The nozzle assembly is formed of 1,280 nozzles arranged at 600-dpi intervals in a zigzag pattern, offering a total of 2,560 nozzles 1,200-dpi intervals.

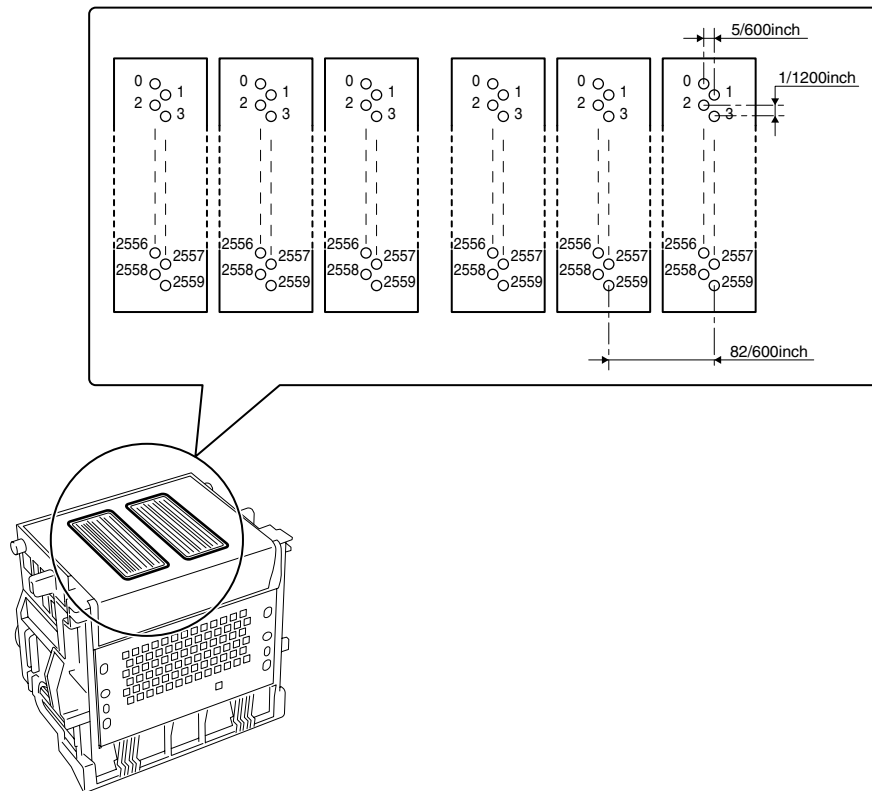

F-2-10

b) Nozzle assembly structure

Inks supplied from the ink tanks are filtered through a mesh ink filter before being sent to the nozzle assembly.

Each nozzle train is supplied with an ink from the common nozzle chamber.

A head drive current subsequently flowing through the nozzle heater boils the ink, generating bubbles to discharge ink drops from the nozzle assembly.

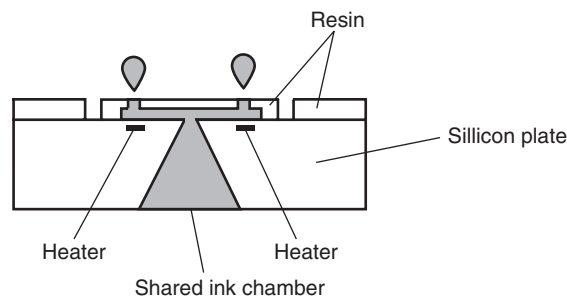

F-2-11

2.3.2.5 Purge Unit

2.3.2.5.1 Functions of Purge Unit

The purge unit maintains the nozzle assembly of the printhead to maintain print quality.

Functions provided by the purge unit include capping, cleaning and ink supply.

a) Capping function

The capping function presses the caps in the purge unit against the face plate of the nozzle assembly in the printhead to protect from drying and foreign matter adherence.

Capping takes place at the end of printing, during a suction operation and when the printer stands by in the wake of an error occurrence.

The capping function connects the printhead to the ink passage of the purge unit.

b) Cleaning function

The cleaning function restores the nozzle to facilitate ink discharges through them.

It consists of the following three operations:

- Wiping operation

Wipes off paper fibers or residual inks adhering to the face plate of the printhead.

- Pumping operation

Sucks inks from the nozzle assembly and refreshes the inside of the nozzles with inks.

- Maintenance jet operation

Discharges inks from the nozzle assembly to the caps or to the maintenance jet tray and paper surface to remove bubbles in the nozzles and dust around the ink discharge ports.

The cleaning function is described below.

0012-6344

T-2-7

Cleaning mode	Name	Cleaning operation
Cleaning 1	Normal cleaning	Removes fixed inks caused by dried nozzles and viscous ink matters adhering to their faces, paperdust and so on.
Cleaning 2	Cleaning on ink level adjustment	Performs normal cleaning after suction for ink level adjustment in the head.
Cleaning 3	Cleaning on initial filling	Performs normal cleaning after filling empty tubes with inks (at initial installation).
Cleaning 4	Ink drainage on head replacement	Drains the head of head replacement (inks left in the head only).
Cleaning 5	Ink drainage on secondary shipping	Drains the head and tubes of inks to prepare for secondary shipping.
Cleaning 6	Normal (high) cleaning	Adjusts the rate of ink filling in the head and performs higher suction to clear clogged nozzles than does normal cleaning.
Cleaning 7	Aging	Performs maintenance jet following head replacement.
Cleaning 10	Ink filling on secondary shipping	Perform normal cleaning after filling empty tubes with inks (at installation after secondary shipping).
Cleaning 15	Dot count suction	Performs a suction operation to remove fixed inks caused by dried nozzles and viscous ink matters adhering to their faces when a predetermined dot count is reached.
Cleaning 16	Agitation on settling	Agitates the ink in a tank to keep it from settling (by opening and closing the ink supply valve),
Cleaning 17	Cleaning, low	Performs lower suction to clear clogged nozzles than does normal cleaning.

The cleaning operation is executed at the following timing.

T-2-8

Printer status		Cleaning operation
Standby	On each lapse of 168 minutes in a capped state	Maintenance jet
	168 hours or more elapsed, capped	Cleaning 1 (Normal cleaning)
	720 hours or more elapsed, capped	Cleaning 6 (Normal (high) cleaning)
	960 hours or more elapsed, capped	Cleaning 2 (Ink level adjusting and cleaning)
	Initial installation and 168 hours elapsed, capped, since the last session of agitation on settling (Cleaning 16)	Cleaning 16 (Agitation on settling)
Power on	Initial installation	Cleaning 3 (Cleaning on initial filling)
	Powered on less than 72 hours after the abnormal termination of a print operation (uncapped)	Cleaning 1 (Normal cleaning)
	Powered on 72 or more hours after the abnormal termination of a print operation (uncapped)	Cleaning 6 (Normal (high) cleaning)
	Powered on at initial installation and 168 hours elapsed, capped, since the last session of agitation and settlement (Cleaning 16)	Cleaning 16 (Agitation on settling)
	Powered on 720 hours or more after the successful completion of a print operation (capped)	Cleaning 6 (Cleaning on ink level adjustment)
	Powered off less than 960 hours after the successful completion of a print operation (capped)	Cleaning 2 (Cleaning on ink level adjustment)
Powered off	Powered off, uncapped	Wiping + Maintenance jet + Idle suction + Capping
Before the start of a print operation	Before the start of a print operation less than 168 hours elapsed, capped	Maintenance jet
	Before the start of a print operation 168 hours or more elapsed, capped	Cleaning 1 (Normal cleaning)
	Before the start of a print operation in the wake of an error occurrence	Cleaning 1 (Normal cleaning)
	Before the start of a remaining roll media volume pattern	Temperature regulator on > Uncap > Stop and maintenance jet > Temperature regulator off > Cap
Printing	Between scans while printing	Maintenance jet + Wiping
At the end of a print operation	After the end of a print operation past a predetermined dot count	Cleaning 15 (dot count suction) or Cleaning 6 (normal (high) cleaning), depending on the count
On execution of the menu action [Head Cleaning]	Manual cleaning (Head cleaning A)	Cleaning 1 (Normal cleaning)
	Manual cleaning (Head cleaning B)	Cleaning 6 (Normal (high) cleaning)
On execution of the menu action [Replace P.head]	On execution of Replace P.head from the menu	Cleaning 4 (Ink drainage on head replacement)
	After head replacement	Cleaning 2 (Cleaning on ink level adjustment)
On execution of Move Printer from the menu	After execution of Move Printer from the menu	Cleaning 5 (Ink drainage on secondary Moving)
	After Power-on at secondary installation	Cleaning 10 (Ink filling after secondary shipment)

c) Ink supply function

The suction pumps in the purge unit are activated, together with ink supply valves, during initial filling and ink level adjustment to supply inks from the ink tanks to the printhead.

2.3.2.5.2 Structure of Purge Unit

0012-6341

a) Caps

The caps cap the nozzle assembly in the left printhead during capping and cleaning. The part of the caps that comes into contact with the face plate of the nozzle assembly is made of rubber. Two caps are in position to meet each of the printheads mounted on the carriage (six trains of nozzles).

The caps are activated to protect the nozzle assembly on capping. When the carriage moves to the home position, the caps are elevated by the cap can that is driven by the capping motor, capping the nozzle assembly to protect it. These caps cap the nozzle assembly to suck inks from the printhead by means of the suction pump.

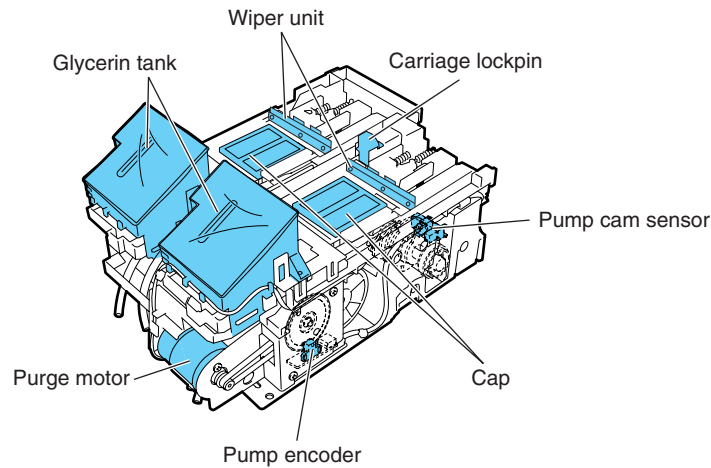

F-2-12

b) Wipers

The wipers are driven by the purge motor to wipe the six trains of nozzles in the nozzle assembly in the printhead simultaneously.

A pair of wiper blades are in position to ensure wiping performance. The wiping operation operates on a slide wiping basis, sliding the wiper blades via wiper cams through the normal rotation normal of the purge motor.

Wiping is executed by the wiper blades moving at a constant speed to the front of the printer after the end of a print or suction operation.

A wiper blade set perpendicularly to the head wipes the entire face of the printhead, followed by a narrower blade wiping the nozzle assembly.

The wiper blades are cleaned before they are replaced at the wiping position after wiping to preserve wiping performance.

Wiper blade cleaning is carried out by scraping off the inks that have been wiped off from the head with an ink scraper linked to the maintenance cartridge, then wiping the blades with a blade cleaner.

Wet wiping is carried out for added wiping removal performance, whereby the wiper blades are moistened with glycerin as they are pressed against an absorber impregnated with glycerin. The quantity of glycerin used is managed by counting the number of times the wiper blades have been pressed against the absorber. When this count falls to equal any of the following values, either a replacement warning (continued print available) or replacement required indication (service call error) is issued.

T-2-9

Display	Times
Replacement warning indication	71,250 times
Service calls	75,000 times

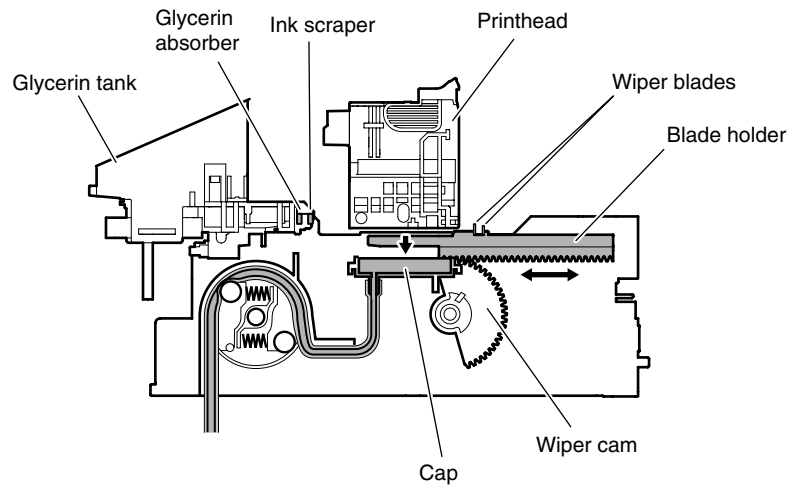

F-2-13

c) Pump

The pump (suction pump) is a tube pump that pressurizes the ink tubes with rotating rollers to generate a negative pressure for sucking inks.

A single tube is sequentially pressurized by a pair of rotating rollers to control the level of ink suction by a wide margin.

The timing at which the rotating rollers rotate is detected by the pump cam sensor, with the distance of rotation being controlled by the driving of the purge motor.

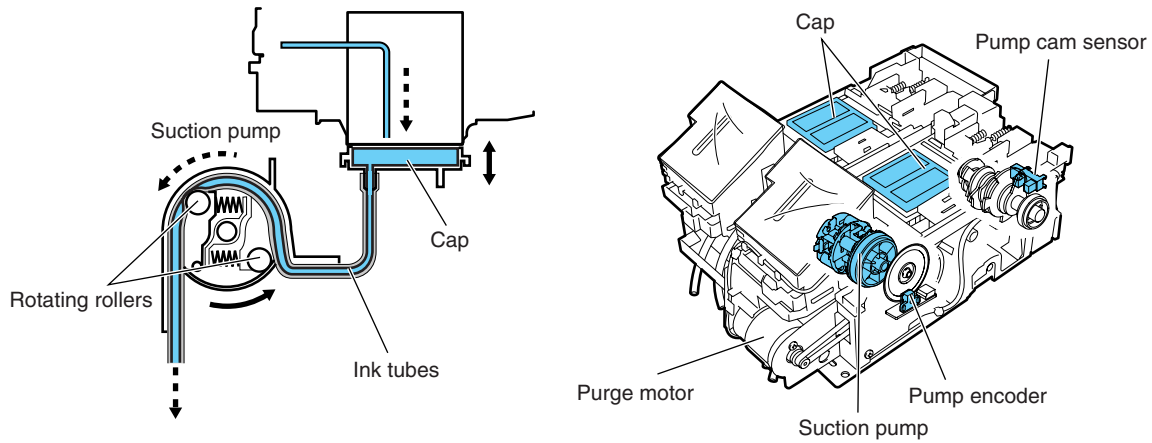

F-2-14

2.3.2.6 Maintenance Cartridge

2.3.2.6.1 Maintenance cartridge

0012-6346

a) Maintenance cartridge

The maintenance cartridge holds as much about 1200 mL of used inks (about 1280 g: including the evaporation of moisture from the used inks).

b) Used maintenance cartridge ink detection

Used maintenance cartridge ink detection is monitored with regard to a dot count.

When the quantity of the used ink reaches about 960 mL (about 1024 g, 80% of the cartridge capacity), the warning message "Maintenance C Space Check" is displayed to tell that the maintenance cartridge is nearly full.

Printing may continue even when the warning message is displayed.

When the quantity of the used ink reaches about 1200 mL (about 1280 g, 100% of the cartridge capacity), a replacement prompt error message is displayed, telling that the maintenance cartridge is full.

When the printer determines that the maintenance cartridge is full, it shuts down even while it is printing.

The printer will remain inoperable until the maintenance cartridge is replaced.

Memo:

- The maintenance cartridge houses EEPROM, so that engine firmware can control the status of the maintenance cartridge by writing to and reading from the EEPROM content.

There is no need to initialize the counter information, therefore, when the maintenance cartridge is replaced.

2.3.2.7 Air Flow

2.3.2.7.1 Air flow

0014-8865

Ink mists floating during printing or springing back from the paper are collected in the mist fan unit by air flow in the printer.

Two mist fans located on the rear side of the printer makes the airflow that carries the ink mists to the mist fan unit.

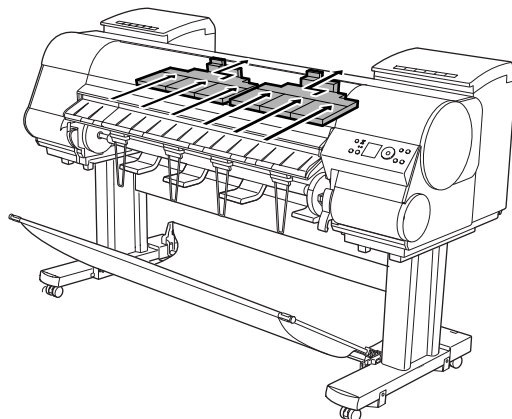

F-2-15

2.3.3 Paper Path

2.3.3.1 Outline

2.3.3.1.1 Overview of Paper Path

0013-8780

The key components of the paper passage consist of a feed roller assembly, a pinch roller drive that locks and releases the pinch roller and sensors that detect the feed status of paper. It feeds paper in trays, conveys and delivers paper.

Basic operation of the paper loading sequence

- 1) Multi sensor light quantity adjustment
- 2) Paper leading edge detection sensor
- 3) Paper left edge detection sensor
- 4) Barcode read
 - * Performed only if Chk Remain.Roll is turned on.
- 5) Paper skew detection sensor
- 6) Paper right edge detection sensor
- 7) Trim edge first detection sensor
 - * Performed only if Trim Edge First is turned on.
- 8) Leading edge cutting
 - * Leading edge cutting is executed under the following conditions.
 - a. Trim Edge First is set to Forced.
 - b. Trim Edge First is set to Automatic, and the need for cutting determined.
 - c. A barcode is detected when Chk Remain.Roll is on (forced cutting, regardless of the setting of Trim Edge First).
- 9) Paper leading edge detection sensor

Basic operation of the cut media loading sequence

- 1) Paper trailing edge detection sensor
- 2) Multi sensor light quantity adjustment
- 3) Paper width detection sensor
- 4) Paper leading edge detection sensor
- 5) Paper skew detection sensor

Memo:

Press the [▼] key while the printer is offline to deliver paper, the [▲] key to rewind the paper.

2.3.3.2 Paper Path

2.3.3.2.1 Structure of Feed Roller Unit

0012-6383

a) Paper feed assembly

The paper feed assembly consists of paper feeding mechanisms, such as a feed roller that is driven by the feed motor and a pinch roller unit that follows up the motion of the feed roller.

Paper feeds horizontally under the printheads on the carriage as it is kept level on the platen to prevent cockling.

b) Sensors

The paper feed assembly includes sensors for detecting the status of paper feeding and that of the mechanical components that make up the paper passage. For more details, see Technical Explanation > Detection Functions.

c) Roll media drive

The paper feed assembly is complete with a roll media spool drive unit to prevent roll media from slacking as they feed. The roll media spool drive unit rewinds roll media by turning on the rewind clutch. The rewind clutch turns on only when roll media feed rearward. Driving force is imparted from the feed motor to rotate the roll holder for rewinding the media. The rewind clutch remains off when roll media feed forward.

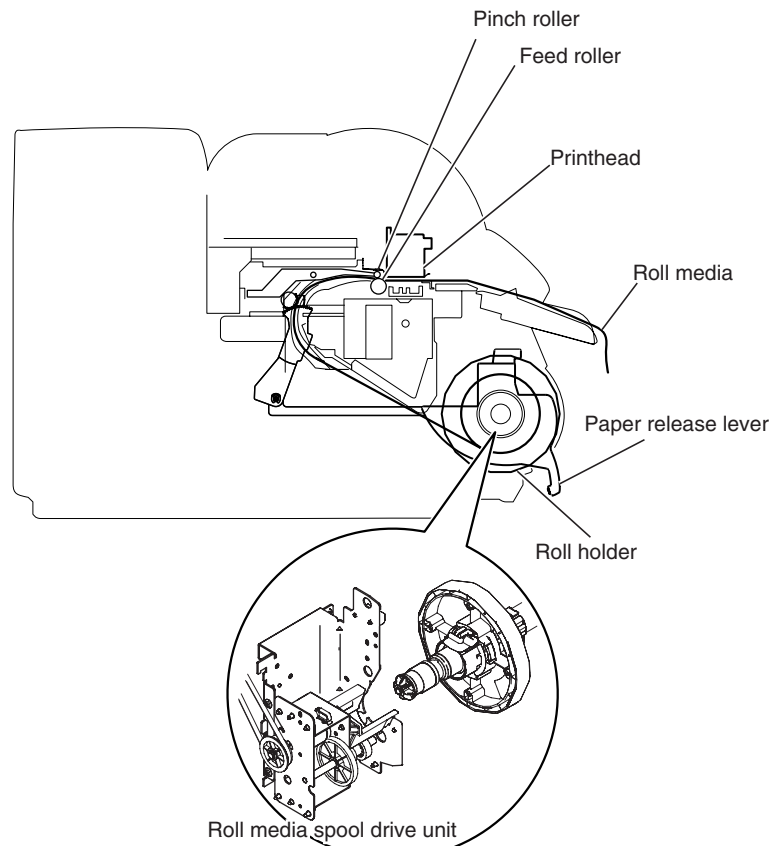

F-2-16

2.3.3.3 Cutter Unit

2.3.3.3.1 Structure of the cutter unit

0012-6386

If the print driver is configured to use a cutter with roll media, cutter unit attached to the left side of the carriage cuts roll media automatically. Cutter unit won't cut roll media if the print driver is configured otherwise.

2.4 Printer Electrical System

2.4.1 Outline

2.4.1.1 Overview

The printer electrical system consists of the main controller PCB and power supply PCB which are mounted on the back side of the printer, the carriage relay PCB, the head relay PCB, and printhead which are mounted in the carriage, the operation panel on the right upper cover and other electrical components such as sensors, and motors.

The main controller PCB manages the image data processing and the entire electrical system, and controls relay PCBs and driver functions.

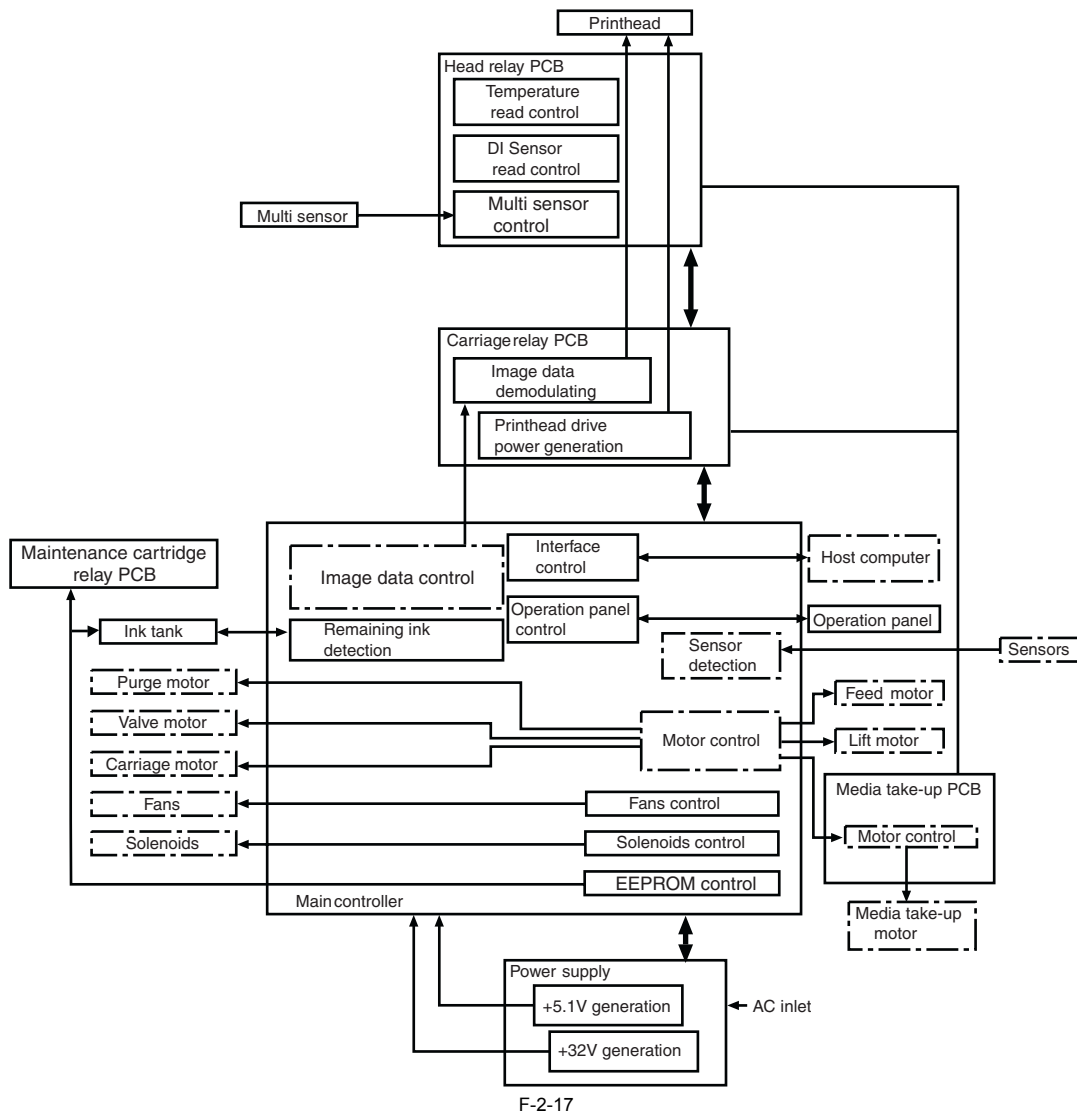

2.4.2 Main Controller

2.4.2.1 Main controller components

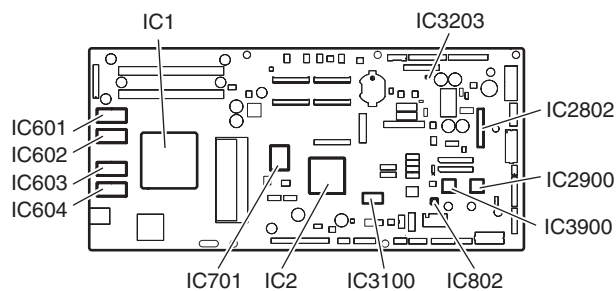

a) ASIC(IC1,IC2)

The ASIC(IC1/IC2) with a 32/16-bit internal bus is driven in sync with the 132/66 MHz external clock. It supports the following functions:

Image processing unit

This unit converts the RGB multi-bit image data or CMYK multi-bit data received from the host computer through the interface connector to the binary image data for the ink colors used.

DMA controller

This controller controls the input interfaces such as the USB and expansion card slot as well as DMA transfer of the data to be stored in the DIMM.

Image data generation/output function

This function generates image data for color printing from the received image data and the mask pattern (corresponding to print mode) stored in the DIMM, and store the generated image data in another DIMM. It also outputs the generated image data to the carriage relay PCB.

Interrupt controller

This controller receives and processes internal interrupts and external interrupts from the USB, image processing unit, and expansion card slot.

Timer function

Even when the printer is turned off, the timer function is held on using the RTC and secondary lithium battery to assist the cleaning function. When the power cord is plugged to the outlet, power is supplied to the RTC and therefore the secondary lithium battery power is not consumed.

Heat Enable signal control function

This function uses the pulse width to perform variable control of the time of application of the Heat Enable signal to the nozzle heater for each nozzle array (PWM control).

Linear scale count function

This function reads the linear scale when the carriage moves, thus generating the ink jet timing. It also counts the linear scale timing cycle using the reference clock to measure the carriage moving speed.

Dot count function

This function counts the fired dots used as the information for Heat Enable signal control, maintenance jet control, cleaning control, and remaining ink level for each nozzle array.

Operation panel control function

This function controls serial communication with the operation panel.

PWM control function

This function controls driving of the suction fan and mist fan as well as the temperature of the printhead.

Remaining ink level detection function

This function detects the remaining level of each color of ink based on the signal received from the hollow needle mounted in the ink tank unit.

LED control function

This function controls the LEDs on the ink tank unit.

I/O port function

This function controls input signals from sensors.

Power ON/OFF control function

This function controls turning on/off of the drive power (32V and 5.1V) supplied from the power supply PCB.

Head DI sensor read control function

This function controls read operation by the head DI sensor.

Multi sensor control function

This function controls the LED, gain adjustment, and controls obtainment of the reading of the multi sensor.

EEPROM control function

This function controls the EEPROMs of individual ink tanks, the maintenance cartridge EEPROM, the EEPROM on the maintenance cartridge relay PCB, and the head EEPROM in addition to the on-board EEPROM.

Motor control function

This function controls the carriage motor, feed motor, valve motor, purge motor, lift motor based on the input signals from sensors.

b) Driver IC (IC3100)

This IC generates a carriage motor control signal based on the control signal from the ASIC.

c) Driver IC (IC2802)

This IC generates feed motor control signal based on the control signal from the ASIC.

d) Driver IC (IC2900)

This IC generates purge motor and valve motor(R) control signals based on the control signal from the ASIC.

e) Driver IC (IC3900)

This IC generates valve motor(L) control signals based on the control signal from the ASIC.

f) Regulator IC (IC3203)

This IC generates the 3.3 V to be supplied to the tank ROM board.

g) DIMMs (IC601, IC602, IC603, IC604)

The DIMM comprising a 512-MB DDR-SDRAM and a 128-MB SDR-SDRAM is connected to the 32-bit data bus to be used as a work area. During print data reception, it is also used as an image buffer. It cannot be expanded.

h) FLASH ROM (IC701)

A 128-MB flash ROM is connected to the 8-bit data bus to store the printer control program.

i) EEPROM (IC802)

The 128-KB EEPROM stores various setting values, adjustment values, log data, counter values related to the user/servicing.

MEMO:

After replacement of the main controller PCB, the printer must be started up in the service mode to take over the setting and adjustment values to the new PCB properly (the service mode will be switched to the PCB replacement mode automatically).

2.4.3 Carriage Relay PCB

2.4.3.1 Carriage relay PCB components

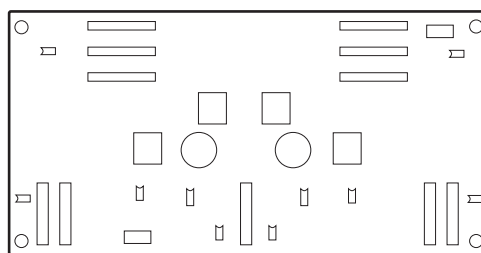

F-2-19

a) Image data relay function

This function relays the image data from the main controller PCB to the printhead. The function for processing image data is not supported.

b) Sensor relay function

This function relays the input signals from the multi sensor, lift cam sensor, carriage cover sensor, and linear encoder to the main controller PCB.

2.4.4 Head Relay PCB

2.4.4.1 Head relay PCB components

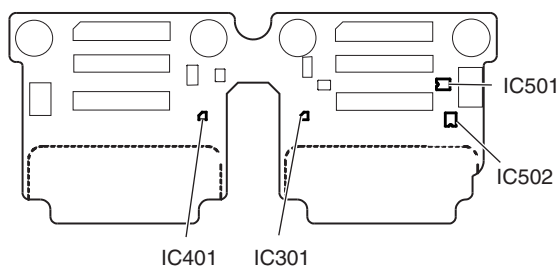

F-2-20

a) Latch IC (IC301,IC401)

DI sensor read control function

Obtains reading value of the DI sensor in the printhead and the head rank value for each color and outputs them to the main controller based on the control commands from the main controller.

Environment temperature read control function

Outputs the environment temperature detected by the thermistor on the head relay PCB to the main controller based on the control commands from the main controller.

Relay function of the power to the logic components in the printhead

Supplies the power to the logic components in the printhead based on the control commands from the main controller.

b) Multi sensor control IC (IC501,IC502)

These IC's generates the LED control signals and makes gain adjustment for the multi sensor.

c) Image data relay function

This function relays the image data from the main controller PCB to the printhead.

d) Sensor relay function

This function relays the input signals from the multi sensor, lift cam sensor, carriage cover sensor, and linear encoder to the main controller PCB.

2.4.5 Motor Driver

2.4.5.1 Media take-up unit components

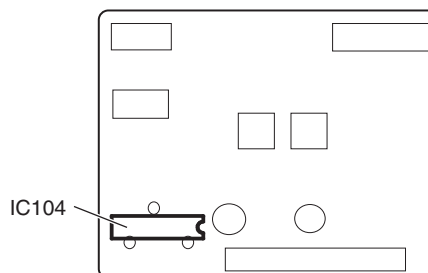

F-2-21

a) Driver IC (IC104)

Media take-up motor drive function

This function controls the Media take-up motor based on the control signals from the main controller.

Sensor relay function

This function relays the input signals from the Media take-up paper detection sensor and Media take-up on/off sensor to the main controller PCB.

2.4.6 Maintenance Cartridge Relay PCB

2.4.6.1 Maintenance cartridge relay PCB components

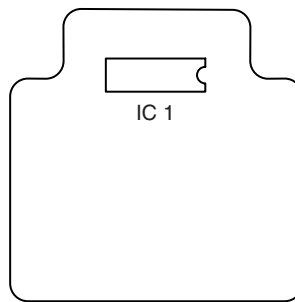

F-2-22

a) EEPROM (IC1)

The 128-KB EEPROM stores all information written in the EEPROM on the main controller PCB.

2.4.7 Power Supply

2.4.7.1 Power supply block diagram

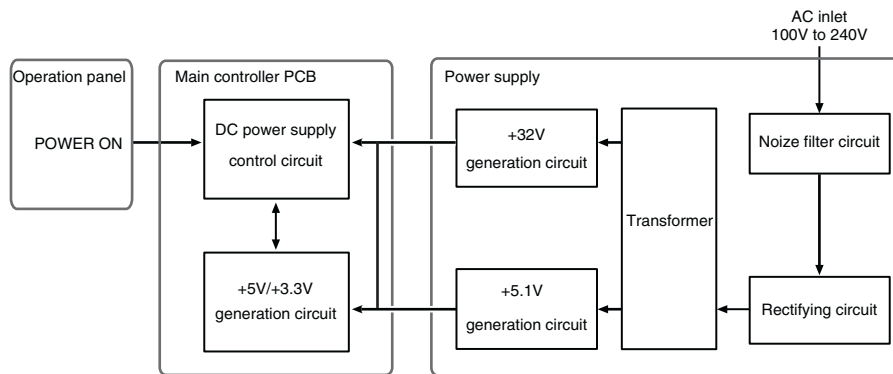

F-2-23

The power supply converts AC voltages ranging from 100 V to 240 V from the AC inlet to DC voltages for driving the ICs, motor, and others.

The voltage generator circuits include the +32 V generation circuit for driving motors, fans, and the +5.1V generator circuit for driving sensors, logic circuits.

When in the power saving mode, the power supply cut outs the +32 V and the +5.1 V.

Power ON/OFF operation is controlled by the main controller PCB. When the upper cover is open, the power supply cut outs only the +32V power to the carriage.

2.5 Detection Functions with Sensors

2.5.1 Cover system

Upper cover lock switch (L) / (R)

The microswitch-based upper cover lock switches detect the open/closed states of the upper cover.

When the upper cover close, the switches are pressed to detect the closed state of the upper cover.

The printer has one switch installed on the left and right sides each to prevent one-sided closure of the upper cover.

Ink tank cover switches (L) / (R)

The microswitch-based ink tank cover switches detect the open/closed states of ink tank covers.

When an ink tank cover closes, the switches are pressed to detect the closed state of the ink tank cover.

Pressure release switch

The microswitch-based pressure release switch detects the status of the paper release lever.

When the paper release lever closes, the switch is pressed to detect the closed state of the paper release lever.

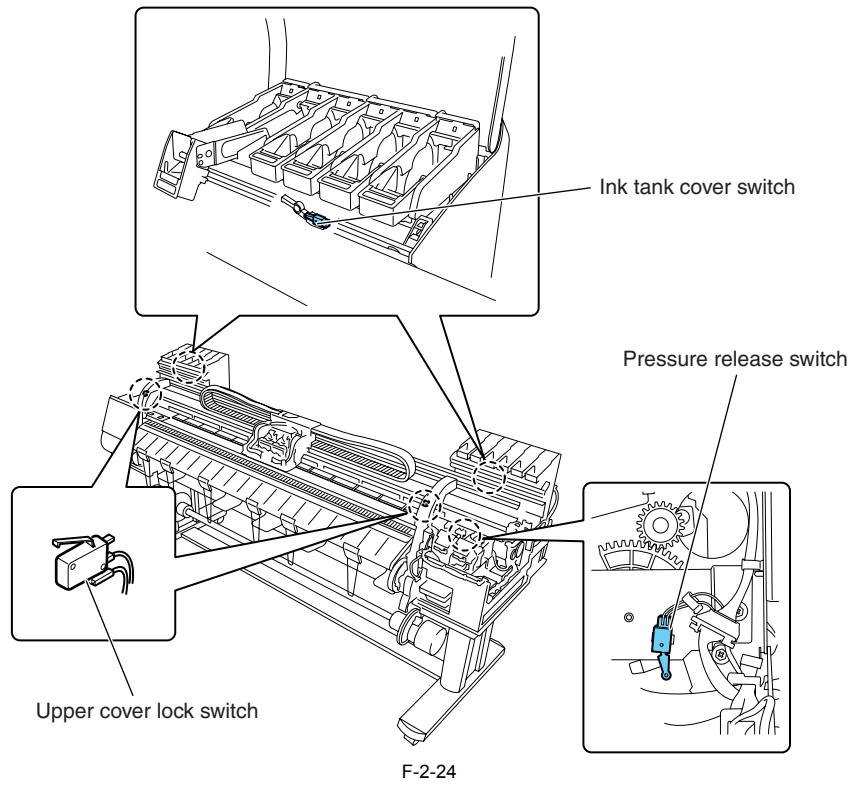

2.5.2 Ink passage system

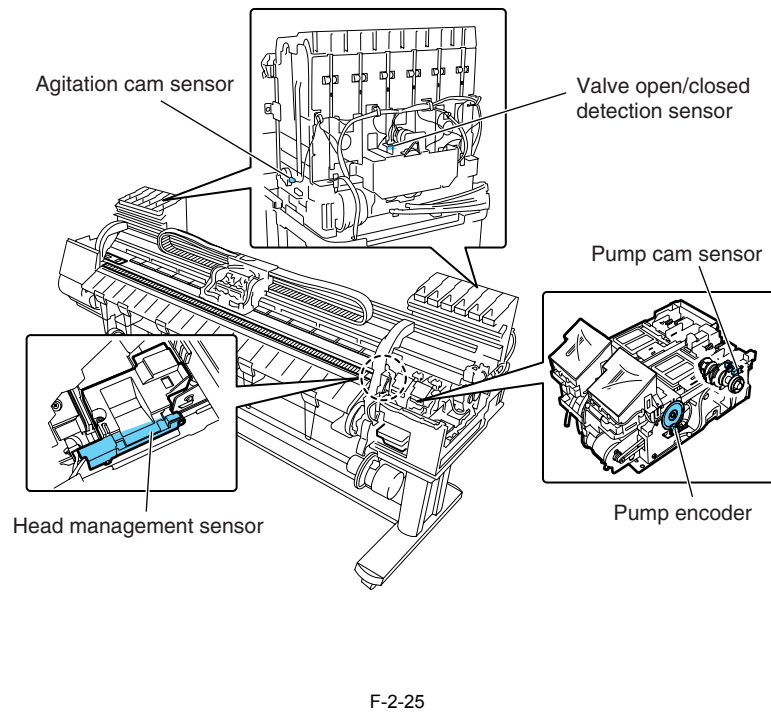

Pump cam sensor

As the cam rotates, it shields the sensor light of the photointerrupter-based pump cam sensor or allows it to be transmitted. the status of the purge unit, such as capped, suction, and wiping, is detected in a Combination of the status of detection by the pump cam sensor and the control of pump motor rotation by the pump encoder sensor.

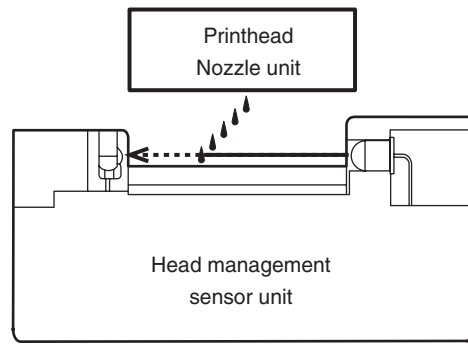

F-2-29

2.5.3 Carriage system

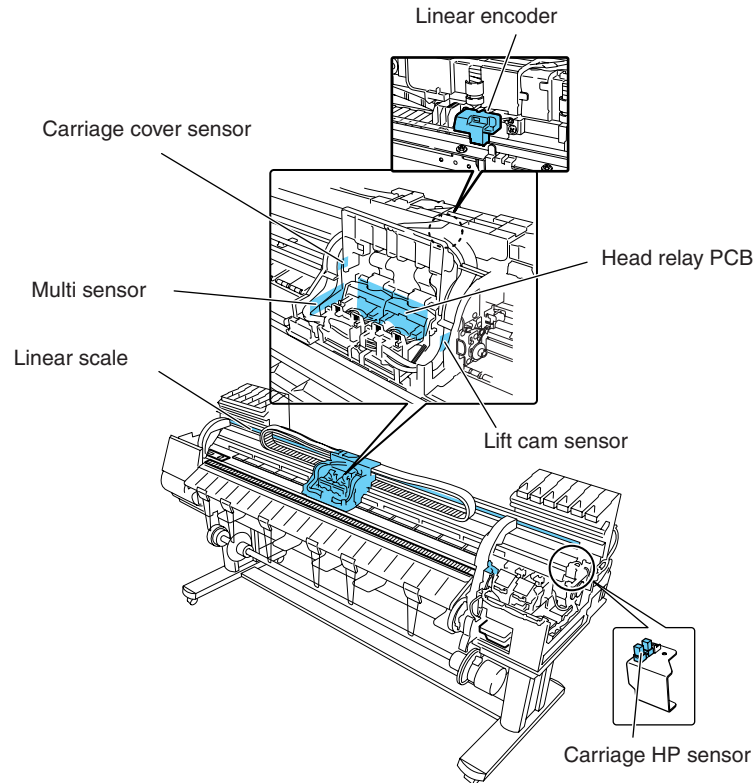

F-2-30

Carriage cover sensor

The photointerrupter-based carriage cover sensor detects the opening and closing of the carriage sensor. When the carriage cover is closed, the sensor light is shielded by the sensor arm, enabling the sensor to detect that the carriage cover is closed.

Carriage HP sensor

The photointerrupter-based carriage HP sensor detects the home position of the carriage. Installed on the right side plate of the printer, the sensor detects an edge of the carriage home position on the carriage unit under carriage unit under carriage movement control. The printer establishes the carriage home position from the position at which its edge is detected as a reference position.

Linear encoder

Mounted on the back of the carriage, the linear encoder detects the position of the carriage from a slit in the linear scale during its movement.

Lift cam sensor

A photointerrupter-based sensor. After the sensor light is shielded by the flag, the lift motor is driven by a predetermined number of pulses to regulate the separation between the printheads and platen automatically.

Ambient temperature sensor

The thermostat-based ambient temperature sensor mounted on the head relay PCB detects the ambient temperature to which the carriage is exposed. The resistance of the thermistor that varies as a function of temperature changes in the printer is transmitted to the main controller via the carriage relay PCB. The ambient temperature is used to help calibrate the head temperature sensor and detect abnormal ambient temperatures.

Head temperature sensor

The head temperature sensor detects the temperature of the printhead. The printhead temperature is transmitted to the main controller via the carriage relay PCB. The printhead temperature is used to help control the head drive and detect abnormal printhead temperatures.

Printhead contact detection

The printhead contact detects the status of printhead installation by electrical means. The contact detects the status of contact from voltage changes in the flexible cables on the carriage side that come into contact with two terminals of the printhead with remote contact surfaces, the power terminals and GND terminal.

Multi sensor

The photoreflector-based multi sensor consists of four LEDs (red, blue, green, infrared) and two light-receiving sensors to detect the leading edges and width of paper and skews in it, and to adjust its registration, head height and calibration. At head height adjustment, the two light-receiving sensors detect infrared light reflected upon the paper to work out the head height from differences in its measurement.

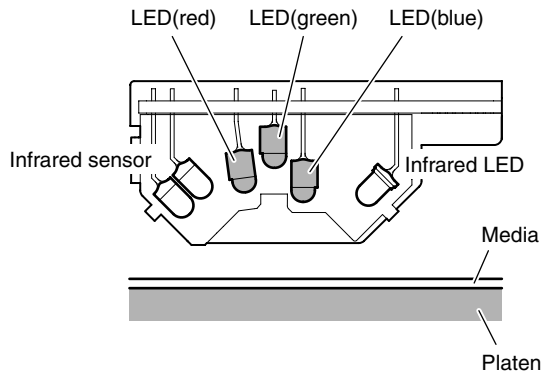

F-2-31

2.5.4 Paper path system

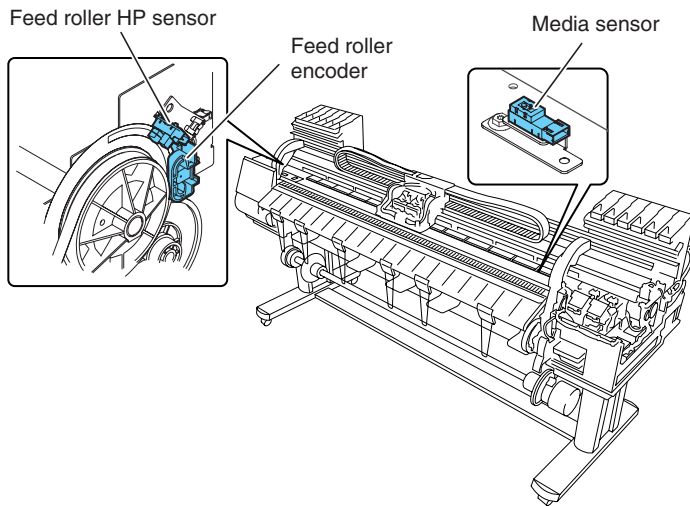

F-2-32

Media sensor

The photoreflector-based media sensor detects the presence or absence of paper on the platen. The sensor detects the presence of paper when it receives sensor light reflected upon the paper.

Feed roller HP sensor

The feed roller HP sensor detects transitions from white (transmitted), or a reference, to black (shielded) when the printer is switched on, thereby setting the home position of feed roller eccentricity correction.

Feed roller encoder

The feed roller encoder is driven to detect the length of paper feeding for each rotation of the feed roller from encoder slits.

2.5.5 Humidity sensor

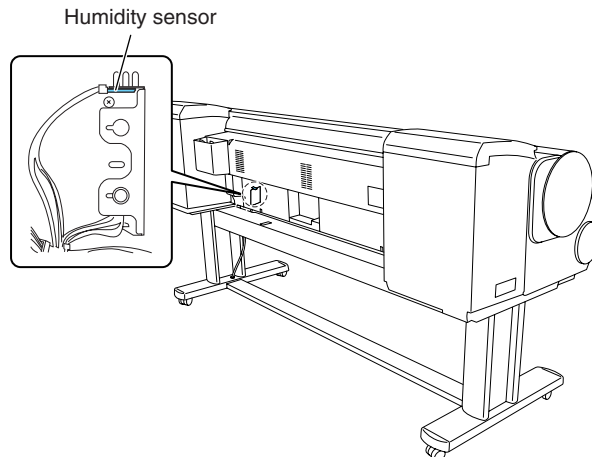

F-2-33

Humidity sensor

The humidity sensor detects the temperature and relative humidity around the printer to implement head height adjustment, maintenance jet control, waste ink evaporation calculation and suction fan control on the basis of the temperature and relative humidity thus measured.

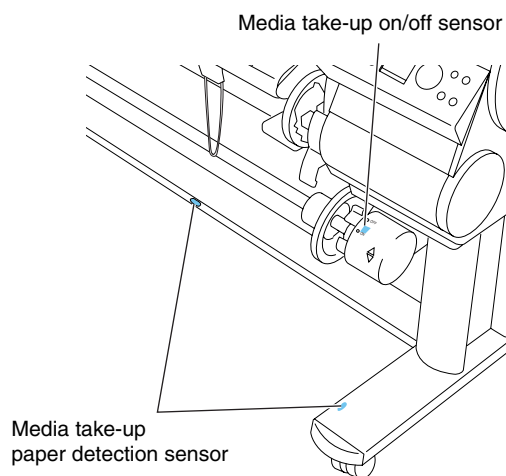
2.5.6 Media take-up Unit

F-2-34

Media take-up on/off sensor

The photointerrupter-based media take-up on/off sensor detects the switch status of the media take-up unit. When the media take-up switch is set to ON, the sensor arm transmits the sensor light, power-on the media take-up unit. When the media take-up switch is set to OFF, the sensor arm shields the sensor light, shutting down the media take-up unit.

Media take-up paper detection sensor

When the sensor light is shielded by a loop of printed paper, the media take-up motor rotates to take up the paper.

Chapter 3 INSTALLATION

Contents

3.1 Installation.....	3-1
3.1.1 Making Pre-Checks.....	3-1
3.1.1.1 Making Pre-Checks.....	3-1
3.1.2 Unpacking and Installation.....	3-1
3.1.2.1 Checking the Contents.....	3-1
3.1.2.2 Assembling the Stand.....	3-3
3.1.2.3 Installing the Printer.....	3-6
3.1.2.4 Installing the Basket.....	3-7
3.1.2.5 Installing the Media Take-Up Unit (Option).....	3-11
3.1.2.6 Removing Protection Materials.....	3-17
3.1.3 Checking the Images/Operations.....	3-19
3.1.3.1 Checking the Image and Operation.....	3-19

3.1 Installation

3.1.1 Making Pre-Checks

3.1.1.1 Making Pre-Checks

Follow the instructions in the included "Quick Start Guide" when installing the product. Refer to the package size and weight listed below for smooth carrying in and installation of the product.

T-3-1

Package size and weight
(including palette)

2070mm (W) x 1050mm (D) x 860mm (H)

Approx. 168Kg

1) Installation space

Height

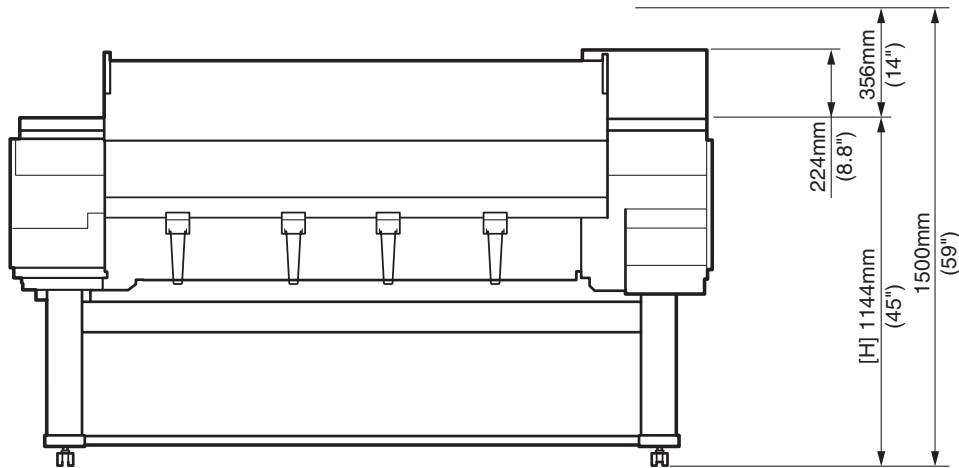

F-3-1

Width and depth

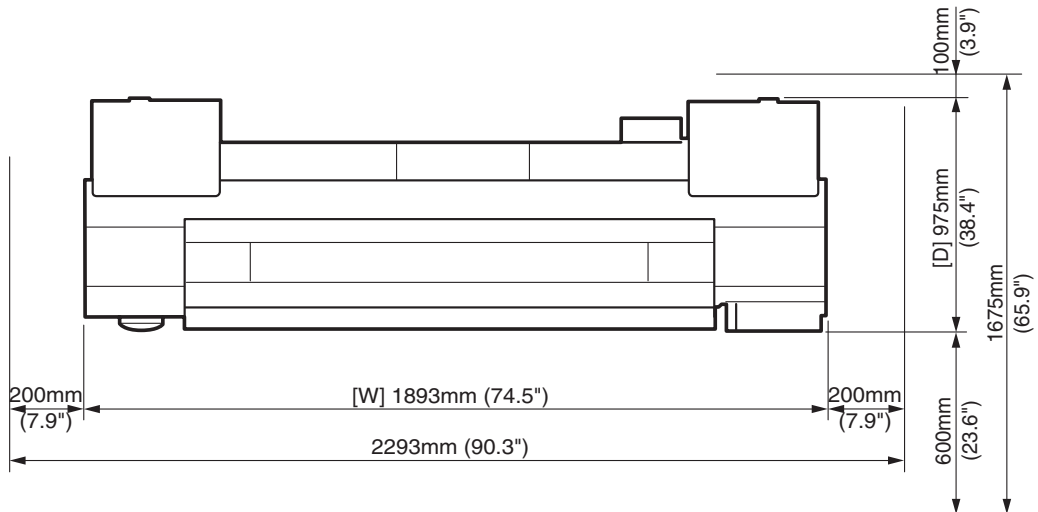

F-3-2

3.1.2 Unpacking and Installation

3.1.2.1 Checking the Contents

1) Check for the components.

a) Printer

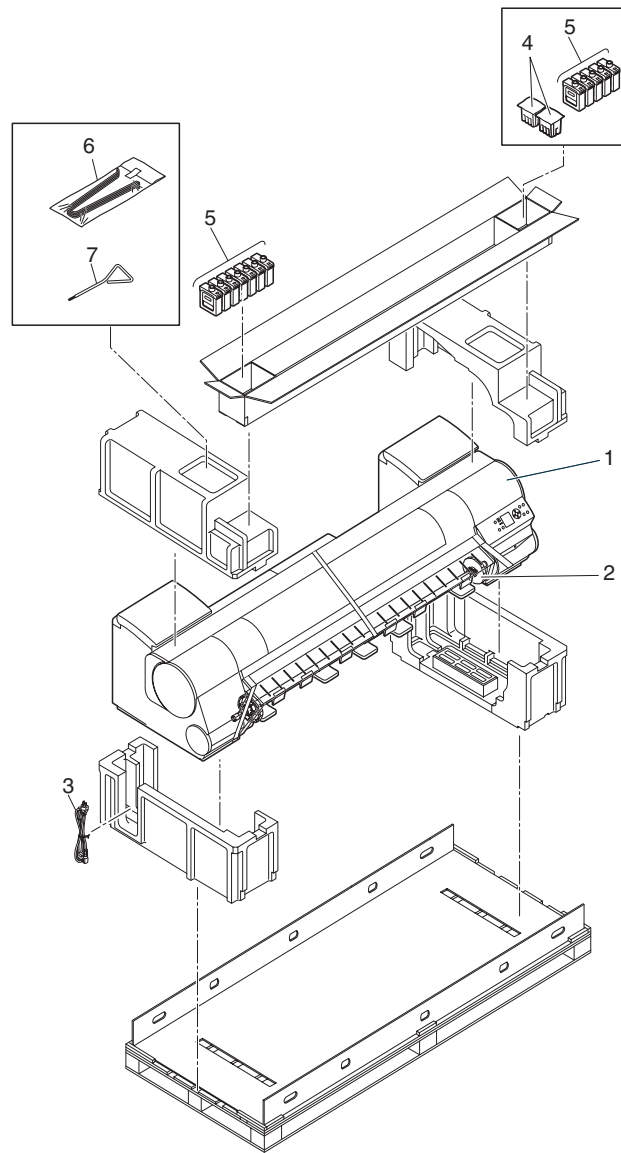

F-3-3
T-3-2

- | | | | |
|---|-----------------------|---|------------------------|
| 1 | Printer | 2 | Roll holder |
| 3 | Power cord | 4 | Printheads (2pcs.) |
| 5 | Ink tanks (12 colors) | 6 | Eject supports (4pcs.) |
| 7 | Hex wrench | | |

b) Stand and basket

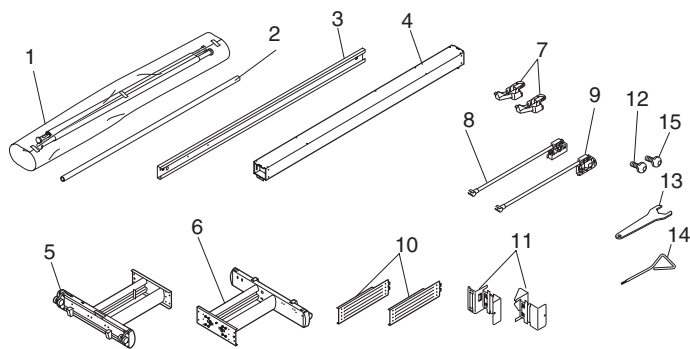

F-3-4
T-3-3

- | | | | |
|---|--------------------|---|----------------|
| 1 | Basket unit | 2 | Basket rod |
| 3 | Bottom stand stay | 4 | Top stand stay |
| 5 | Right stand leg | 6 | Left stand leg |
| 7 | Rod holder (2pcs.) | 8 | Basket arm L |

- | | | | |
|----|----------------------------|----|----------------------|
| 9 | Basket arm R | 10 | Leg cover (2pcs.) |
| 11 | Rod holder adapter (2pcs.) | 12 | M8 hex bolts (8pcs.) |
| 13 | Spanner | 14 | Hex wrench |
| 15 | M4 hex screws (20pcs.) | | |

c) Media take-up unit (option)

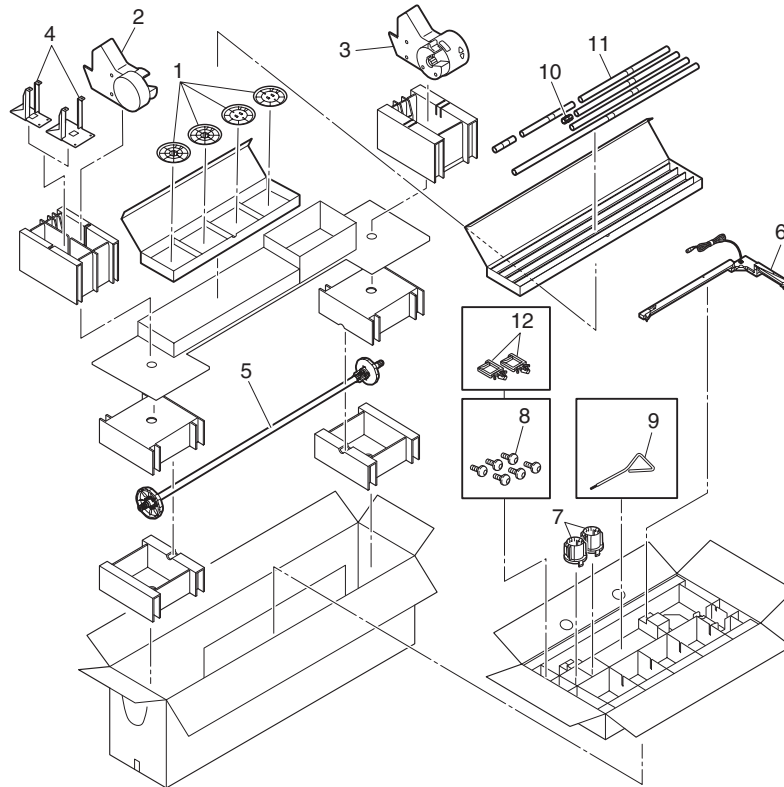

F-3-5
T-3-4

- | | | | |
|----|----------------------------------|----|---|
| 1 | Weight flange 1 / 2 (2pcs. each) | 2 | Media take-up unit L |
| 3 | Media take-up unit R | 4 | Media take-up unit mounting bracket L / R |
| 5 | Media take-up spool | 6 | Media take-up sensor unit |
| 7 | 3-inch adapter (2pcs.) | 8 | M4 hex screws (16pcs.) |
| 9 | Hex wrench | 10 | Weight joint |
| 11 | Weight roll | 12 | Cord holder (2pcs.) |

3.1.2.2 Assembling the Stand

Assemble the stand.



Stand assembly requires two or more people working on a flat floor. Assembling the stand alone may cause injury or accidental bending of the stand. Stand casters are locked at the time of factory shipment. Do not release the lock until the stand has been fully assembled. In addition, release the lock before moving the stand. Moving the stand while the casters are locked may scratch the floor or cause injury.

1) Position the left stand leg and right stand leg so that the markings on the bottom are right-side up and can be read. Insert the left side of the bottom stand stay into the side slot [1] of the left stand leg, and insert the right side of the bottom stand stay into the side slot [2] of the right stand leg.

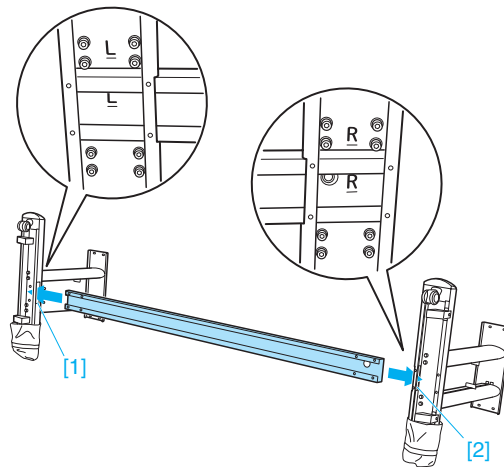

F-3-6

2) Secure the bottom stand stay to the left stand leg and the right stand leg using four M4 hex screws on each side.

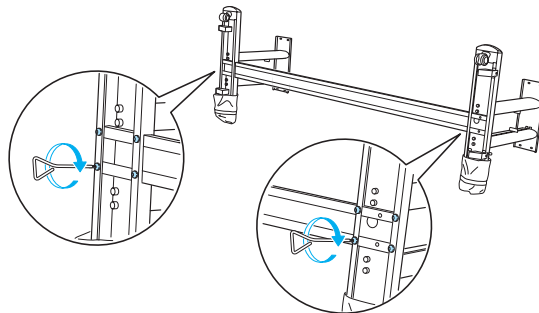

F-3-7

3) Hold one end of the stand while a partner holds the other end. Rotate both ends of the stand at the same time to stand it upright.

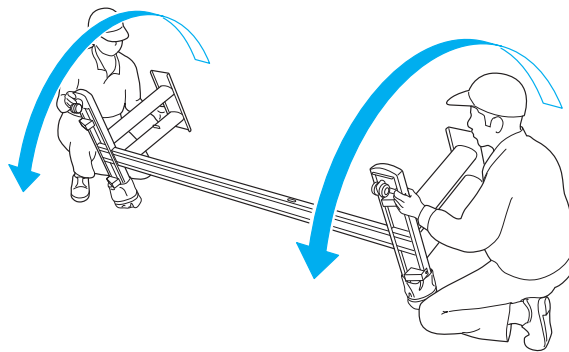

F-3-8



Rotate both ends of the stand simultaneously when standing the stand upright. Rotating only one side before the other may bend the stand and cause problems in assembly.

4) Insert the left end of the top stand stay into the side hole [1] on the left stand leg, and insert the right end of the top stand stay into the side hole [2] on the right stand leg, pushing the stay in completely.

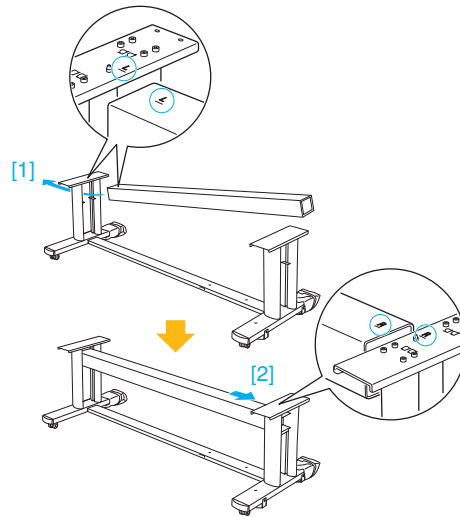

F-3-9

MEMO:

Insert the left end of the top stand stay first. The right end can only be pushed into a restricted position.

5) Secure the top stand stay to the left and right stand legs using the four M8 hex bolts on each side.

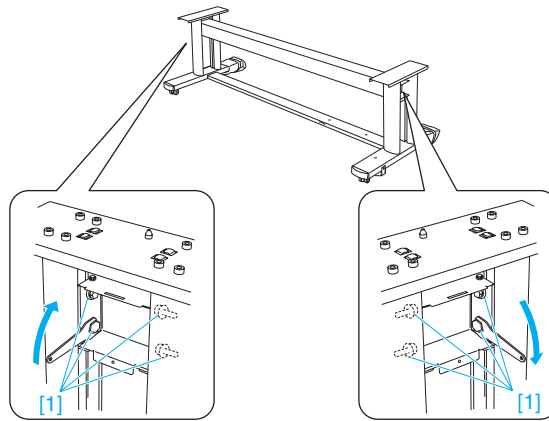

F-3-10

6) Attach the leg cover to the left and right stand legs. Insert the protrusion [1] of the leg cover into the groove [2] of the top stand stay. Insert the protrusion [3] of the leg cover into the groove [4] of the bottom stand stay.

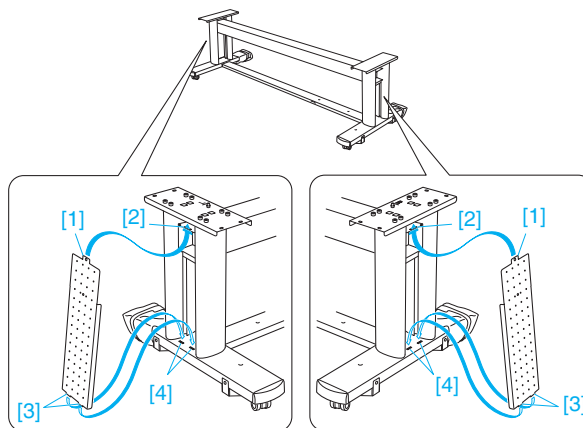

F-3-11

7) Secure the leg cover to the left and right stand legs using one M4 hex screws on each side.

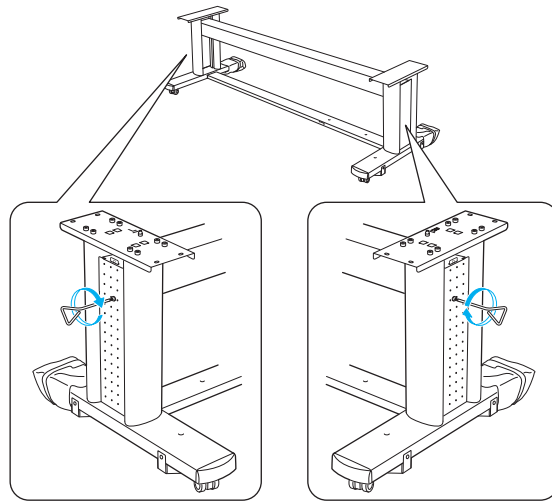

F-3-12

3.1.2.3 Installing the Printer

Installing the printer must be done by more than four people.

- 1) Remove the black belts from around the printer and remove the top packaging material.

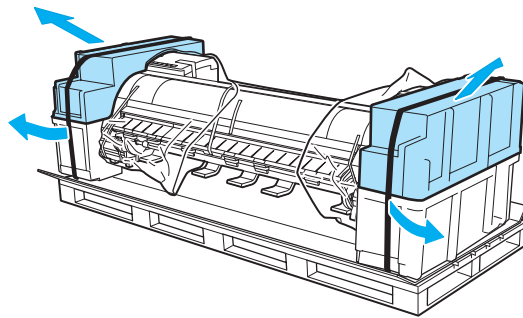

F-3-13

- 2) While two people are holding the carrying handles under the printer on one end and lifting the printer a little, have a third person to remove the packaging material from under the printer.
Also remove the packaging material on the other side of the printer by the same way.

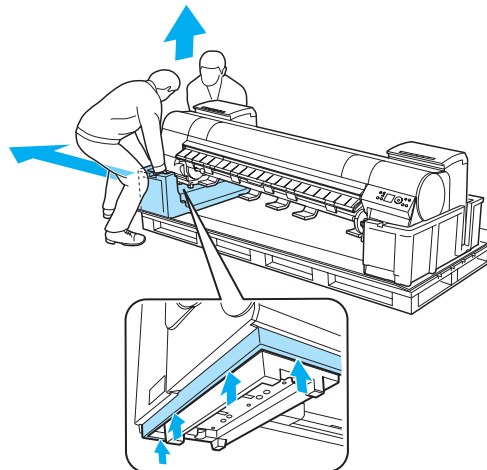

F-3-14

- 3) Hold the carrying handles under the printer by two to three people on each side, lift the printer.

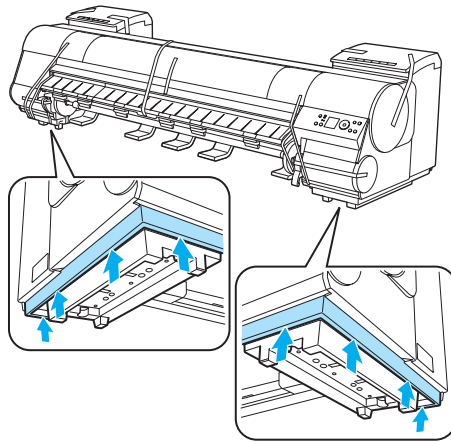

F-3-15

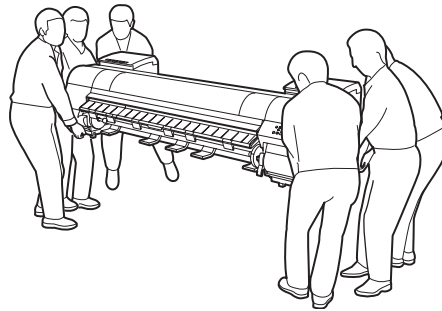

F-3-16



The printer weighs approximately 111kg (244.7lb). Moving the printer requires at least four people, two on either side. Be careful to avoid back strain and other injuries. When moving the printer, firmly grasp the carrying handles under each side. Holding the printer at other positions is dangerous and may cause injury and damage if the printer is dropped.

4) Align the triangles on the back of the printer and the stand when setting the printer on the stand. Secure the printer and the stand firmly together using four M4 hex screws on each side.

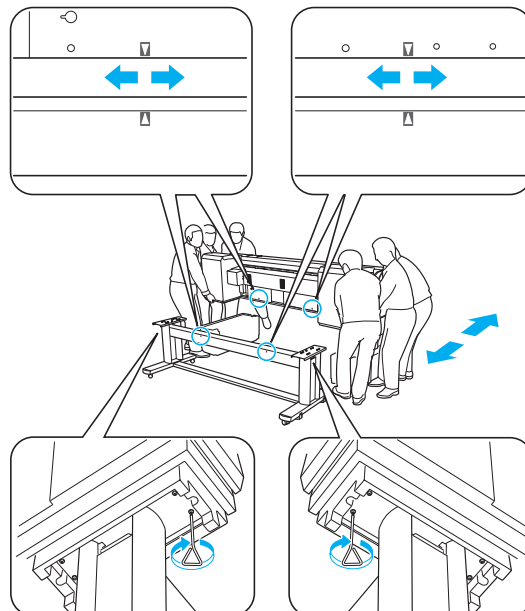

F-3-17

3.1.2.4 Installing the Basket

Install the basket.

1) Insert the basket arm R [1] in the hole [2] on the right side of the bottom stand stay. Insert the right side [3] of the middle basket rod in the hole [4] of the basket arm R.

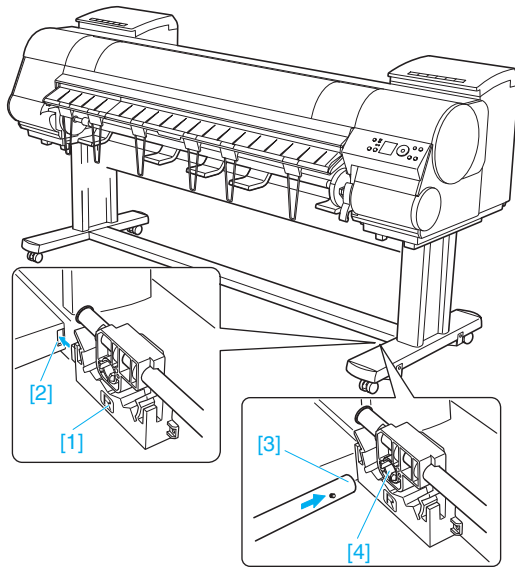

F-3-18

2) Insert the left side of the middle basket rod to the basket arm L [1] [A], then push in the arm fully into the hole on the left side of the bottom stand stay [B]. Secure the basket arm L [1] and R [2] using one M4 hex screw on each side [C].

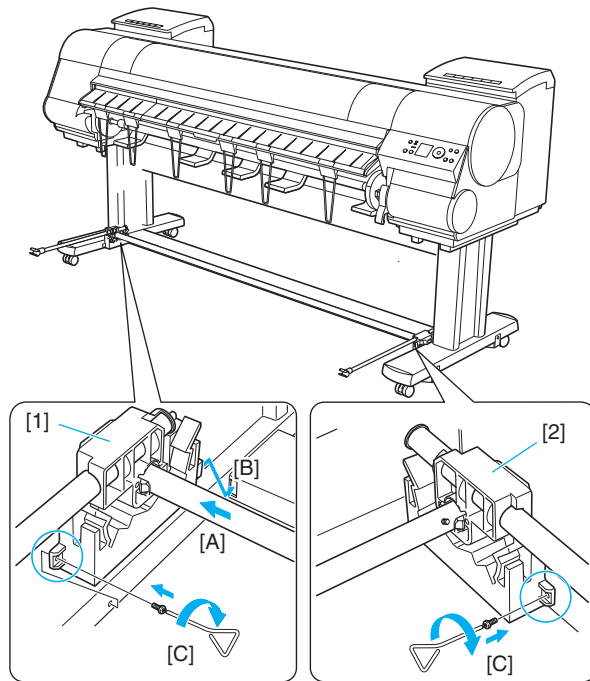

F-3-19

3) Attach the rod holder to the rod holder adapter.

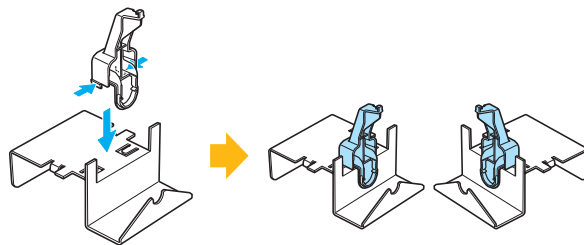

F-3-20

4) Insert the rod holder into each hole on the back of each stand leg.

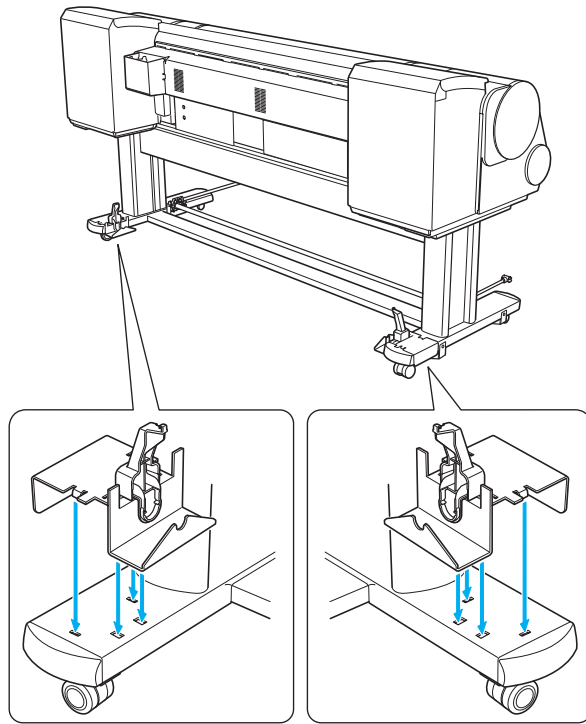

F-3-21

5) Spread out the basket unit with white tag [1] of the basket cloth at the front on the right side and the black cord [2] at the back.

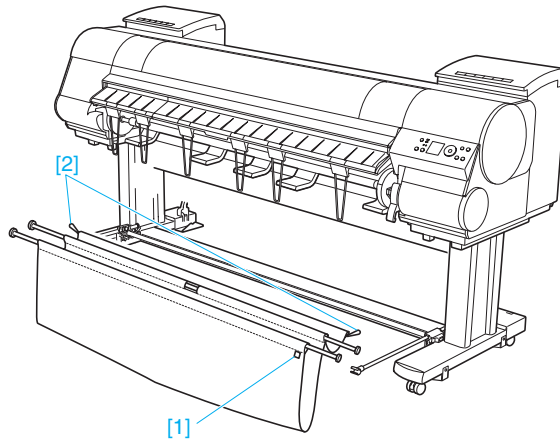

F-3-22

6) Insert the basket rod (in the middle of the basket cloth) in the hole [1] on the bottom of the rod holder, and thread the black cord from the back through the hook [2] on the top of the rod holder.

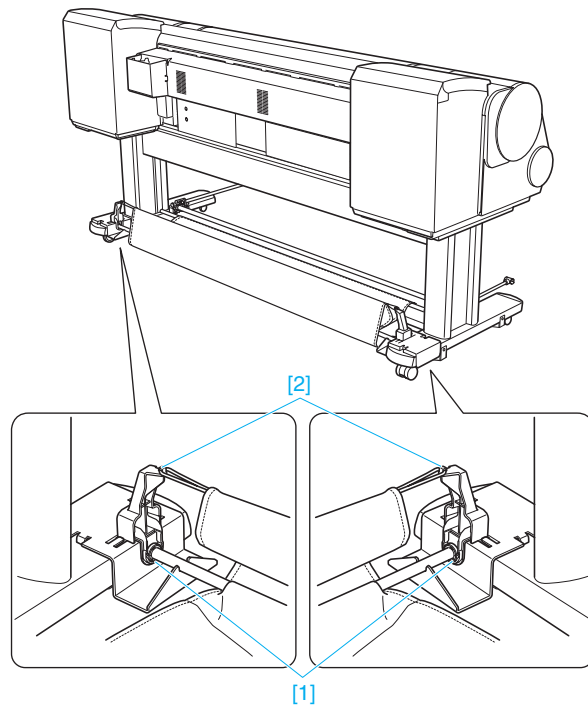

F-3-23

7) Pull out the basket cloth with the edge facing out. Bringing the edge of the basket cloth inside may prevent paper ejection.

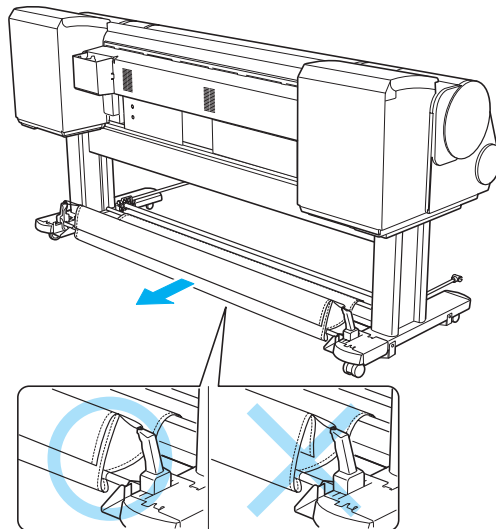

F-3-24

8) Attach the basket rod (at the front of the basket unit) to the tips [1] of the basket arm L and R.

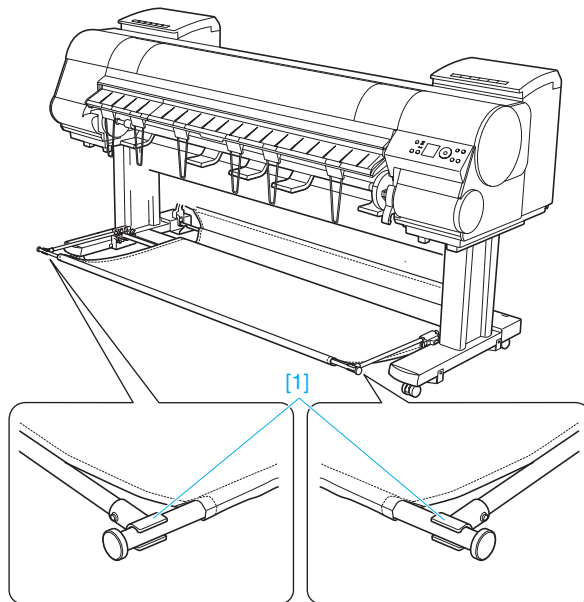

F-3-25

9) Pull the basket rod [1] (at the front of the basket unit) all the way out and lift the rod to lock the rod in place.

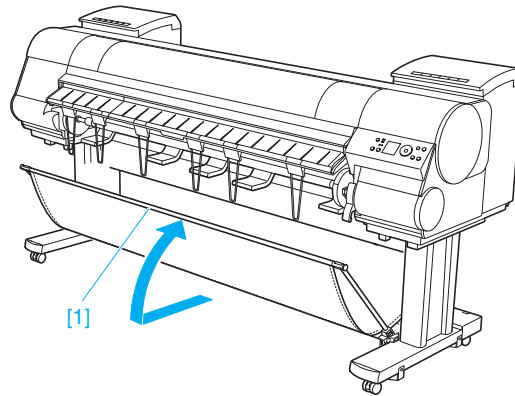

F-3-26

3.1.2.5 Installing the Media Take-Up Unit (Option)

Install the media take-up unit (option)

1) In case the basket is installed, lift the front basket rod [1] gently to release the lock, lower the rod toward the front, and push it all the way back. Remove the front basket rod from the basket arms L and R, then roll up the basket cloth and put it behind the bottom stand stay.

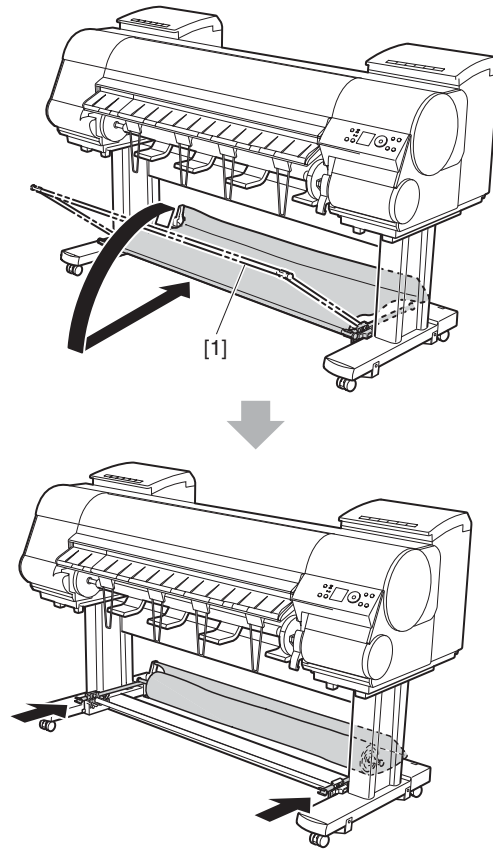

F-3-27

2) Firmly secure the left and right media take-up unit mounting brackets to the front [1] and the back [2] of the top stand stay using four M4 hex screws on each side.

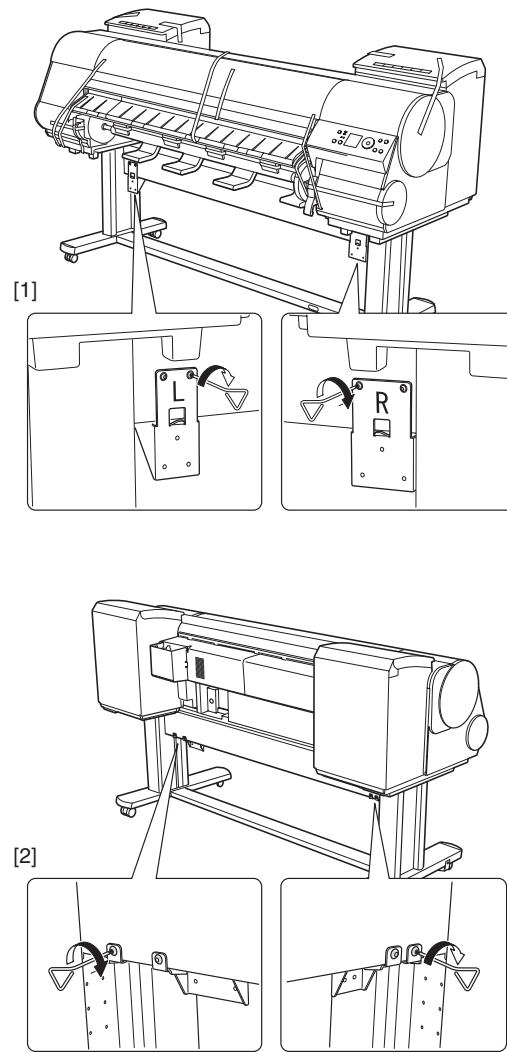

F-3-28

3) Hook up the hole [1] of the left media take-up unit with the protrusion [2] of the left media take-up unit mounting bracket, and hook up the hole [3] of the right media take-up unit with the protrusion [4] on the right media take-up unit mounting bracket. Secure the media take-up units firmly by using three M4 hex screws [5] on each side.

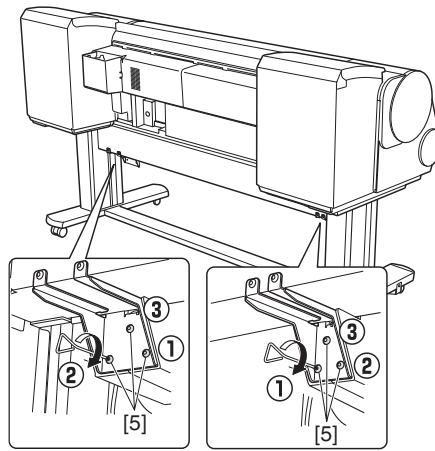
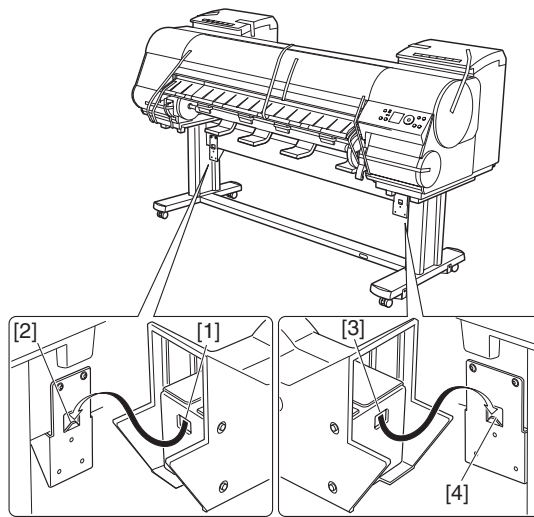

F-3-29

4) Place the media take-up sensor unit under the bottom stand stay, then pull up the cord of the media take-up sensor unit through the hole of the right stand leg.

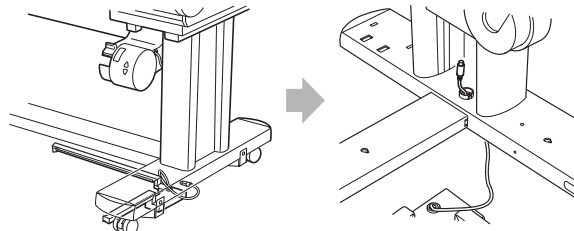

F-3-30

5) With the media take-up sensor unit against the underside of the bottom stand stay and the right stand leg, insert M4 hex screws in the three holes [1] and slide the screws out of the way toward the narrow end of the protruding holes. Insert M4 hex screws in the small holes [2] as well. Then, tighten all five M4 hex screws firmly.

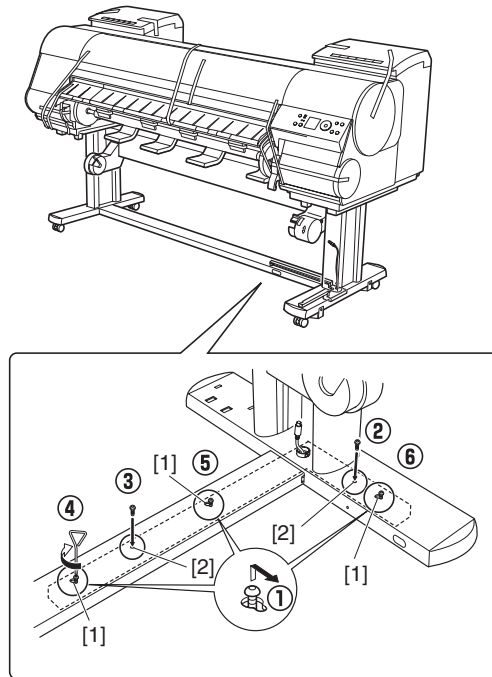

F-3-31



Arrange the basket cloth and basket rod so they do not interfere with the media take-up sensor (indicated by the dotted line).

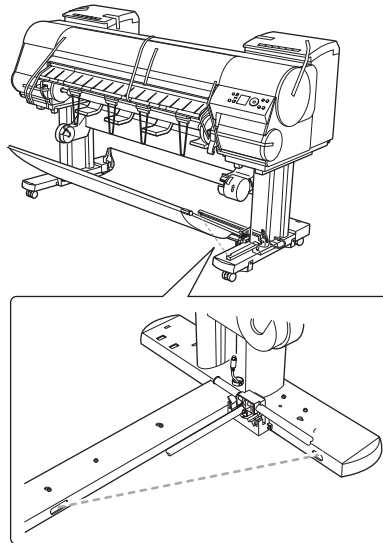

F-3-32

6) Plug the cord of the media take-up sensor unit into the right media take-up unit.

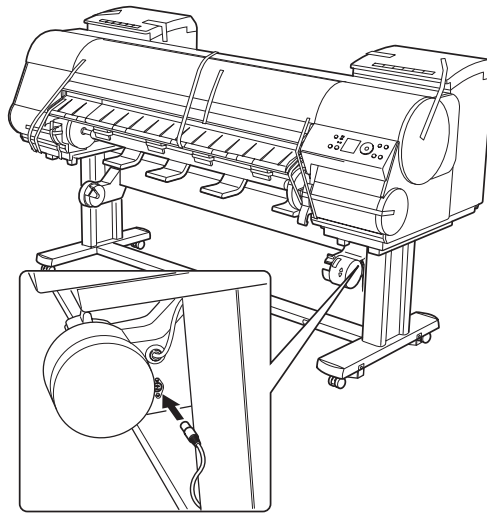

F-3-33

7) Attach the cord holders [1] to the holes of the top stand stay. Bring the power cord of the right media take-up unit to the back of the printer and pass the cord through the cord holders. After passing the cord behind the holders, plug the cord into the power supply connector on the back of the printer.

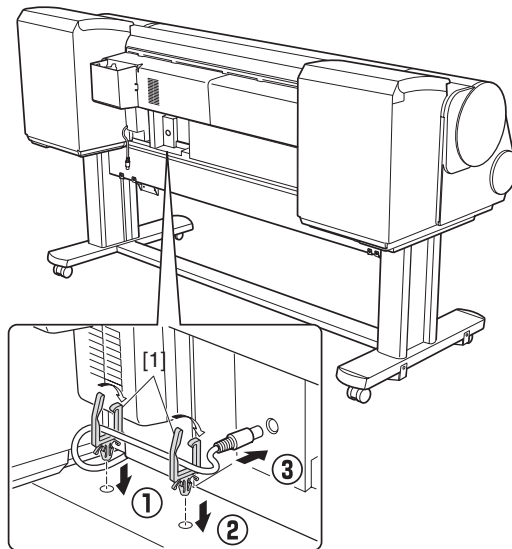

F-3-34



When plugging in the power cord, be careful about the positions of the prongs. It may damage the cord or connector if you force the cord into the connector.

8) Load the left side of the media take-up spool on the media take-up unit so that the gear [1] on the right side of the media take-up spool meshes with the gear [2] of the right media take-up unit.

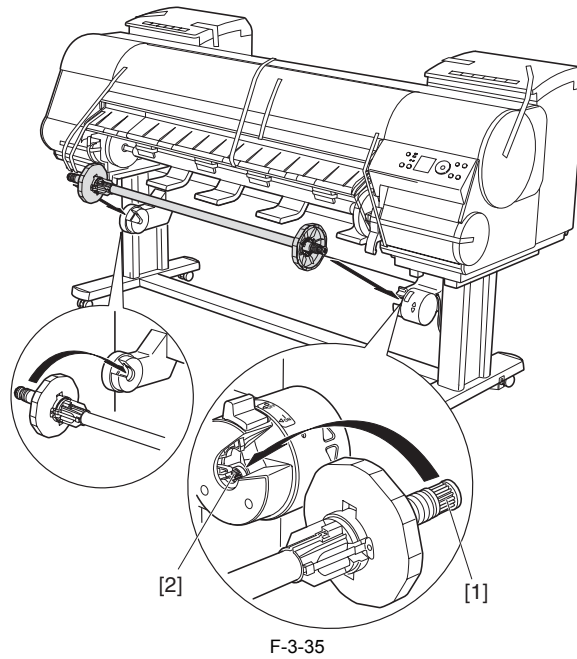

F-3-35

3.1.2.6 Removing Protection Materials

1) Remove the tape and other packaging material used to secure the printer.

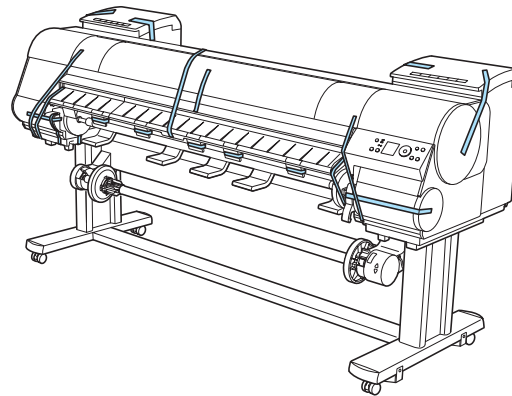

F-3-36

2) Open the upper cover.

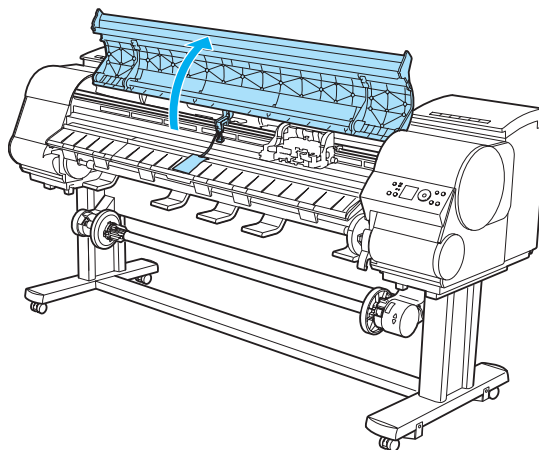

F-3-37

3) Lift the release lever [1] [A], remove the protective sheet [2] from the platen, and lower the release lever again [B].

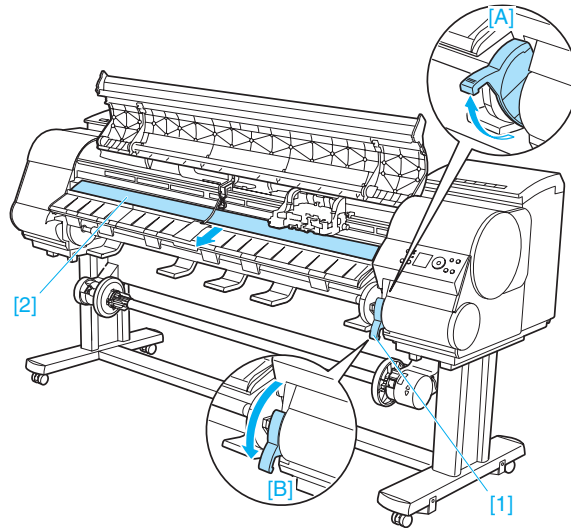

F-3-38

4) Remove the screw and remove the belt stopper [1].

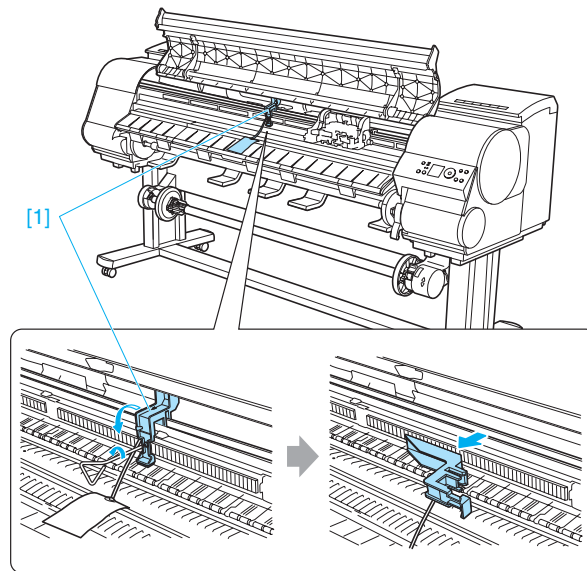

F-3-39

MEMO:

Keep the belt stopper, screw, and the hex wrench which have been removed since these are needed when moving the printer to another location later. Neglecting to attach the belt stopper may cause damage to the printer when moving the printer to another location.

5) Lift the ejection guide.

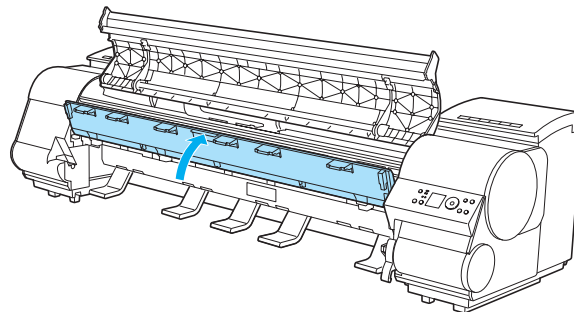

F-3-40

6) Attach four eject supports [1] on the back of the ejection guide.

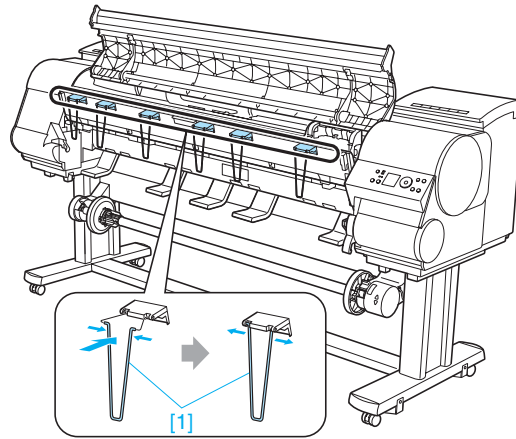

F-3-41

7) Close the ejection guide and the upper cover.

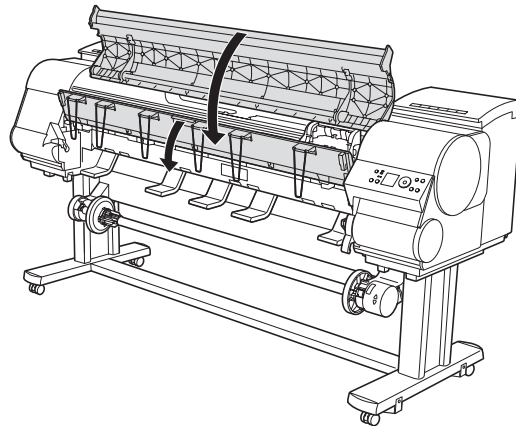

F-3-42

3.1.3 Checking the Images/Operations

3.1.3.1 Checking the Image and Operation

Turn on the printer. Load the print heads, ink tanks, and media following the instructions shown on the operation panel. Install the printer driver in the PC, and carry out test printing.

Chapter 4 DISASSEMBLY/REASSEMBLY

Contents

4.1 Service Parts.....	4-1
4.1.1 Service parts.....	4-1
4.2 Disassembly/Reassembly.....	4-1
4.2.1 Disassembly/Reassembly.....	4-1
4.3 Points to Note on Disassembly and Reassembly.....	4-4
4.3.1 Note on locations prohibited from disassembly.....	4-4
4.3.2 Moving the carriage manually.....	4-4
4.3.3 Units requiring draining of ink.....	4-5
4.3.4 External covers.....	4-5
4.3.5 Drive unit.....	4-11
4.3.6 Carriage unit.....	4-12
4.3.7 Ink tube unit.....	4-16
4.3.8 Feeder unit.....	4-17
4.3.9 Purge unit.....	4-17
4.3.10 Ink tank unit.....	4-18
4.3.11 Linear encoder.....	4-21
4.3.12 Head management sensor.....	4-22
4.3.13 PCBs.....	4-22
4.3.14 Opening the cap and moving the wiper unit.....	4-23
4.3.15 Opening and closing ink supply valves.....	4-23
4.3.16 Draining the ink.....	4-24
4.4 Applying the Grease.....	4-25
4.4.1 Applying the Grease.....	4-25
4.5 Adjustment and Setup Items.....	4-27
4.5.1 Action to take after replacing the feed roller HP sensor, feed roller encoder, or feed roller.....	4-27
4.5.2 Action to take after replacing the carriage unit or multi sensor.....	4-27
4.5.3 Action to take after replacing the head management sensor.....	4-27

4.1 Service Parts

4.1.1 Service parts

The service parts indicated below require careful handling.

1. Keep all packages with the warning not to turn over.

Pay careful attention to all individually packaged service part (carriage unit, purge unit, ink tank unit, and other parts) boxes marked "This side up" and handle appropriately.



F-4-1

2. Feed roller

The feed roller is a functionally important part. Therefore, be careful that the roller is not scratched or marked during storage or transport of the service parts, when removing them from the individual boxes, when assembling, or performing any other operations.

For details about handling of the feed roller, refer to DISASSEMBLY/REASSEMBLY > Points to Note on Disassembly and Reassembly > Feeder unit a) Handling of the feed roller.

4.2 Disassembly/Reassembly

4.2.1 Disassembly/Reassembly

See Parts Catalog for the process of disassembly and reassembly except for the following main units.

Main units are the following four units.

1. Carriage unit
2. Ink tube unit
3. Purge unit
4. Ink tank unit

The parts layout illustrations in parts catalog have figure numbers according to the disassembly procedure of the product.

Main unit disassembly and assembly flows

* Ink drainage in a dotted line performs manual or automatic either.

1. Carriage Unit Disassembly Flow

<Legend > c: Connector h: Hook s: Screw

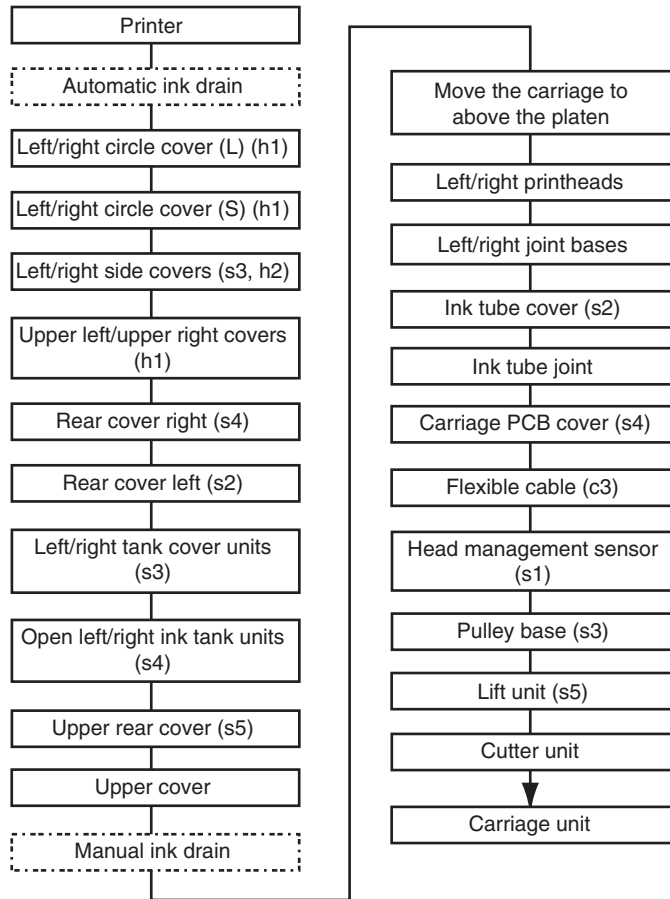

F-4-2

2. Ink Tube Unit Disassembly Flow
 <Legend > c: Connector h: Hook s: Screw

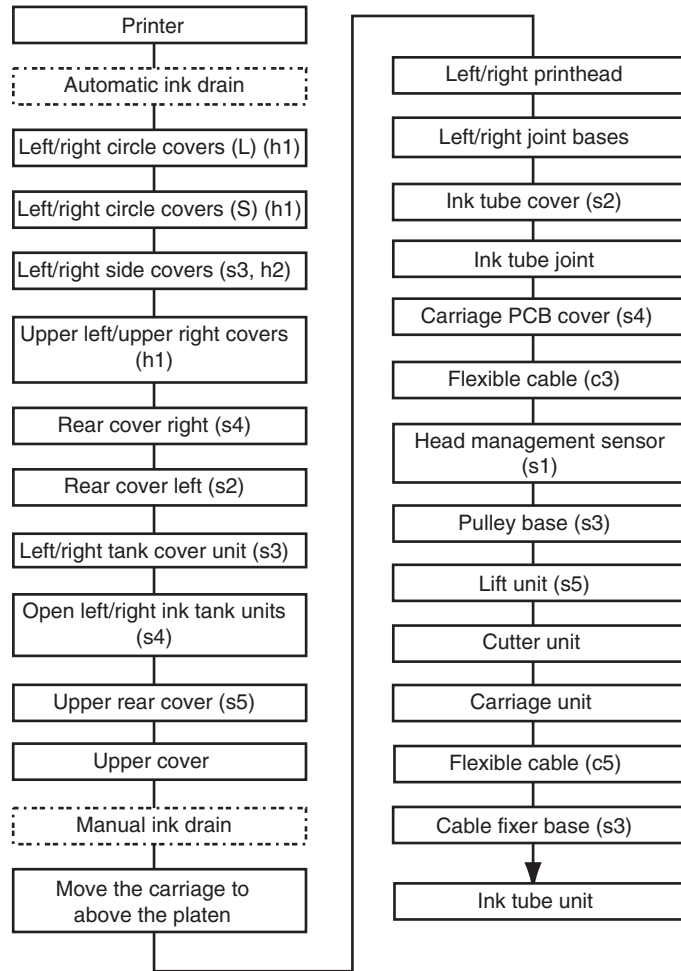

F-4-3

3. Purge Unit Disassembly Flow
 <Legend > c: Connector h: Hook s: Screw

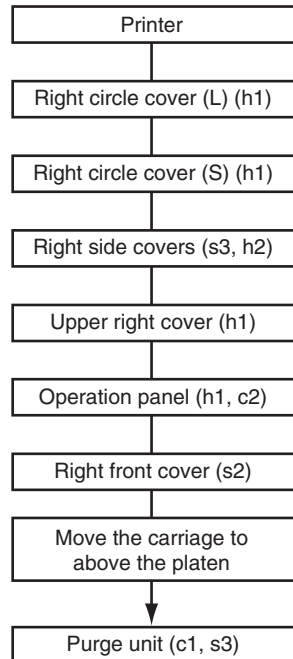

F-4-4

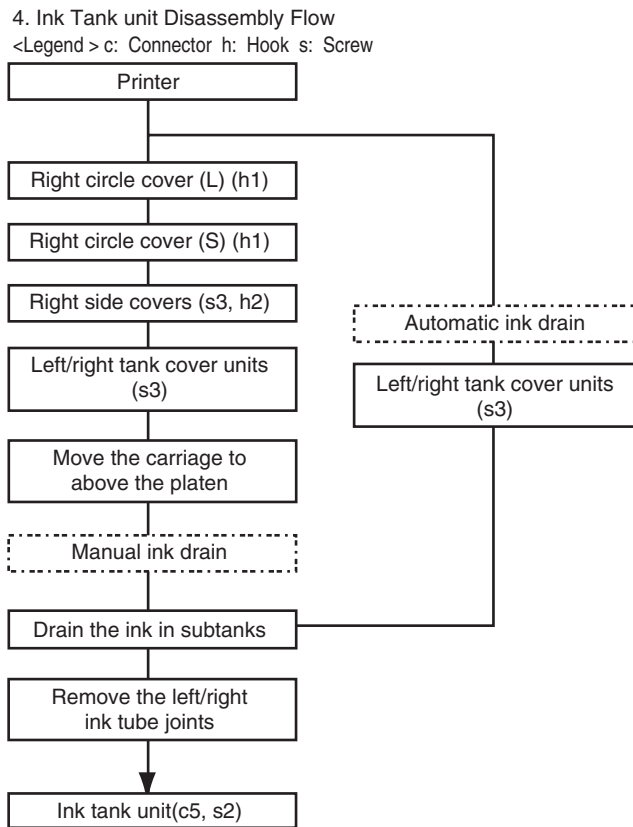

F-4-5

4.3 Points to Note on Disassembly and Reassembly

4.3.1 Note on locations prohibited from disassembly

Points where disassembly is forbidden because they are not accessible to a market adjustment are marked by red screws.



F-4-6

4.3.2 Moving the carriage manually

When moving the carriage, hold it by handle [1] shown below.



Move the carriage as required during assembly and disassembly to prevent the carriage from contacting the parts to be removed. You cannot move the carriage when capping has been performed. Refer to DISASSEMBLY/REASSEMBLY > Points to Notes on Disassembly and Reassembly > Opening the caps and moving the wiper unit to remove the caps, and then move the carriage.

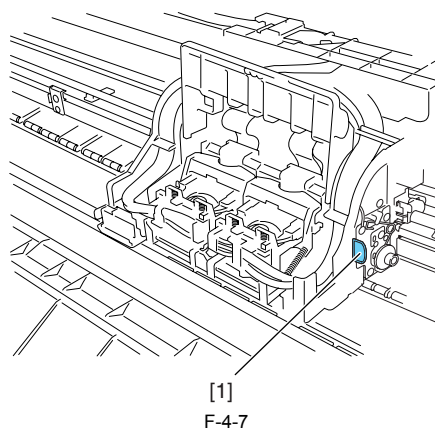

4.3.3 Units requiring draining of ink

When disassembling the following units of the ink passage, drain the filled ink completely to prevent ink leakage. For how to drain the ink, refer to **DISASSEMBLY/REASSEMBLY > Points to Notes on Disassembly and Reassembly > Draining the ink.**

[1] Carriage unit

Refer to **DISASSEMBLY/REASSEMBLY > Points to Notes on Disassembly and Reassembly > Carriage unit.**

[2] Ink tube unit

Refer to **DISASSEMBLY/REASSEMBLY > Points to Notes on Disassembly and Reassembly > Ink tube unit.**

[3] Ink tank unit

Refer to **DISASSEMBLY/REASSEMBLY > Points to Notes on Disassembly and Reassembly > Ink tank unit.**

4.3.4 External covers

a) Left circle cover (L)/Right circle cover (L)

Removing left circle cover (L)/right circle cover (L)

1) To remove circle cover (L) [1], insert flathead screwdriver [2] at the position indicated to remove claw [3] and turn the cover forward to remove.

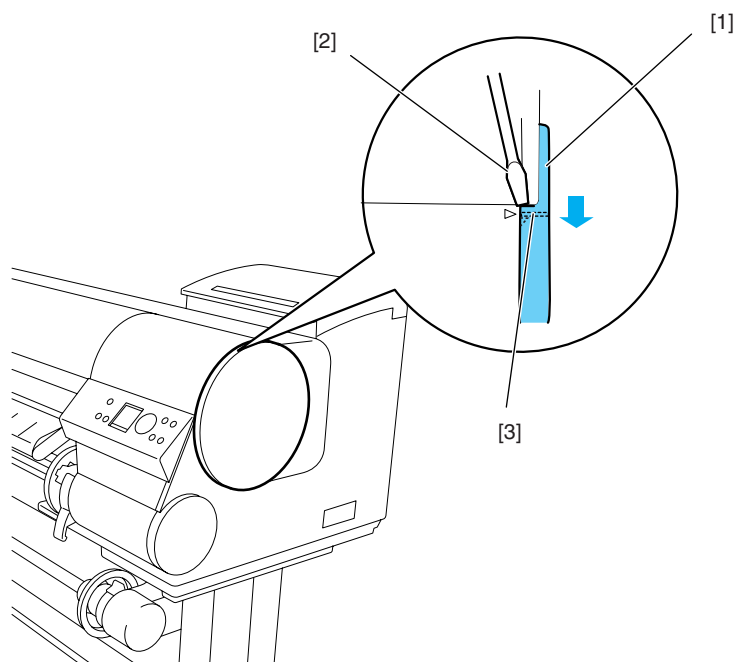

Installing left circle cover (L)/right circle cover (L)

1) Install circle cover (L) [1] with its part [2] inserted in arrow mark [3] of the right side cover and turn the cover backward to install.

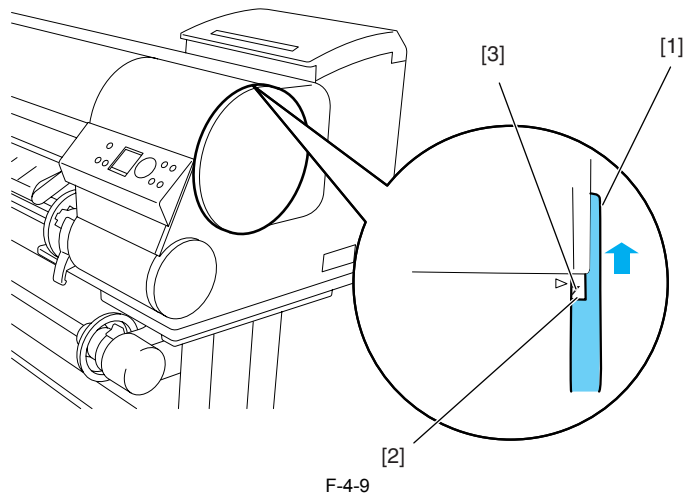

F-4-9

b) Left circle cover (S)/Right circle cover (S)

Removing the left circle cover (S)/right circle cover (S)

1) Remove circle cover (S) [1] by turning it forward to remove the hook

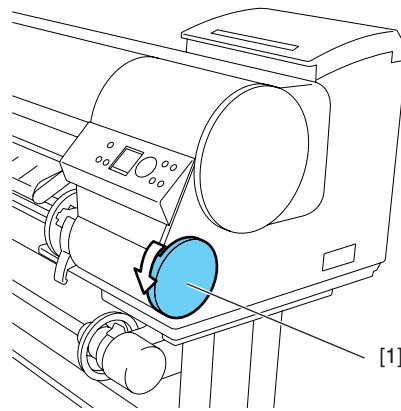

F-4-10

Installing left circle cover (S)/right circle cover (S)

1) Install circle cover (S) [1] with its part [2] inserted in part [3] of the right side cover and turn the cover rearward to install.

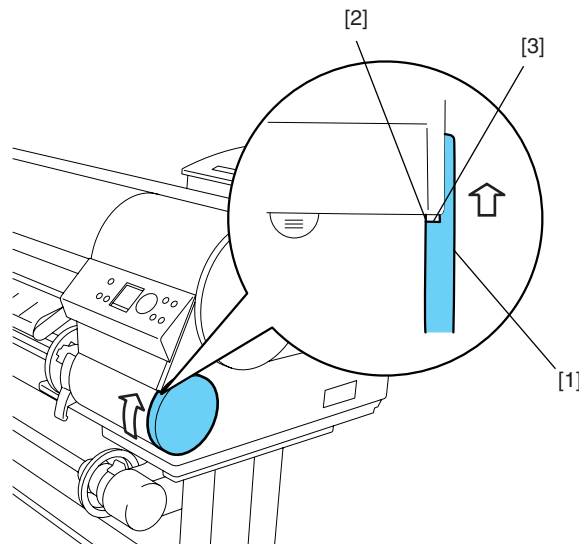

F-4-11

c) Left/ right side covers

Removing the left/ right side covers

1) To remove left/ right side covers [1], remove left/ right circle cover (L) and left/ right circle cover (S).
 2) Remove three screws [2] and two hooks [3], and remove the cover by their bottom side.

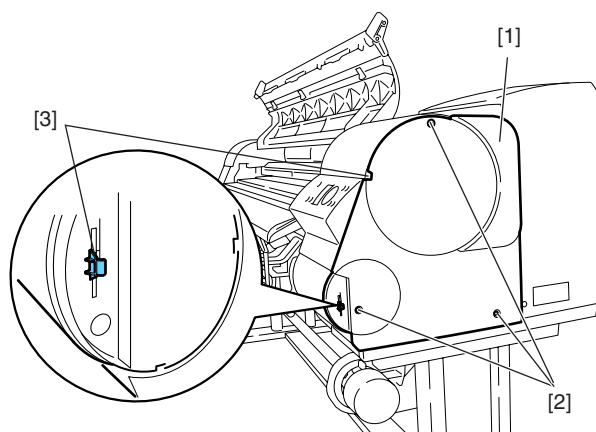

F-4-12

d) Operation panel

Removing the operation panel

- 1) To remove the operation panel [1], remove hook [2] with a flathead screwdriver and remove two connectors [3].

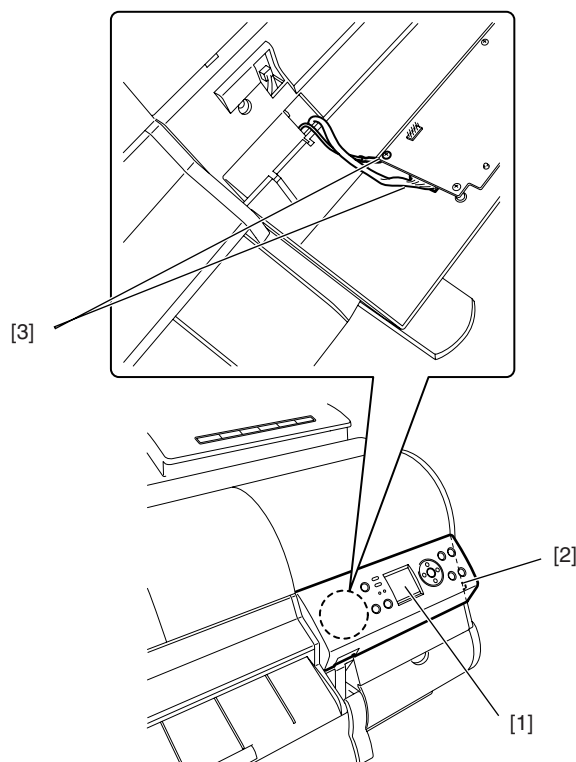

F-4-13

e) Upper left cover/upper right cover

Removing the upper left cover/upper right cover

- 1) To remove upper left/upper right cover [1], remove left/ right circle cover (L), left/ right circle cover (S) and left/ right side covers.
 2) Insert a flathead screwdriver at the indicated position to remove hook [2].

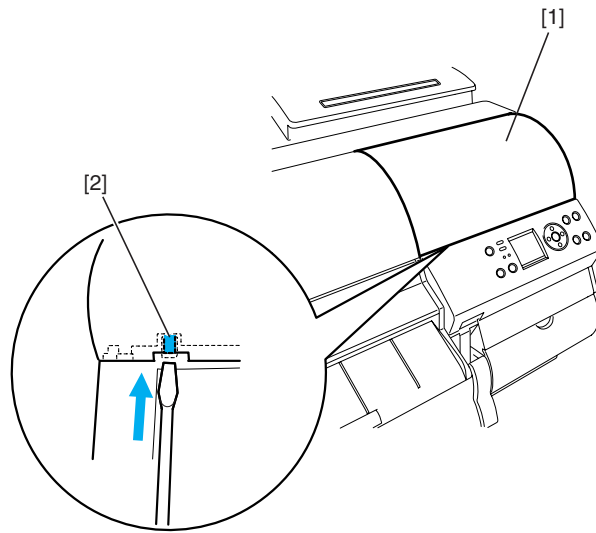

F-4-14

f) Right front cover

Removing the right front cover

- 1) To remove right front cover [1], remove right circle cover (L), right circle cover (S), right side covers, upper right cover the operation panel.
- 2) Remove two screws [2].

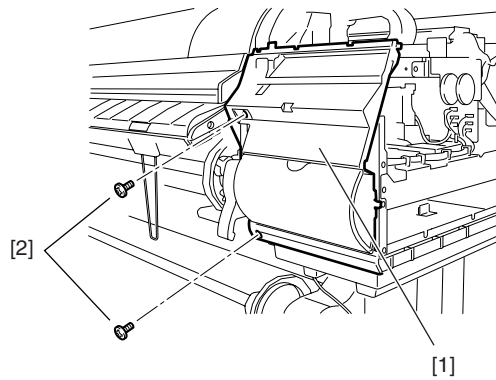

F-4-15

g) Rear cover, right/ rear cover, left

Removing the rear cover, right/ rear cover, left

- 1) To remove rear cover right [1], remove four screws [2].
- 2) To remove rear cover, left [3], remove the rear cover right and two screws [4].

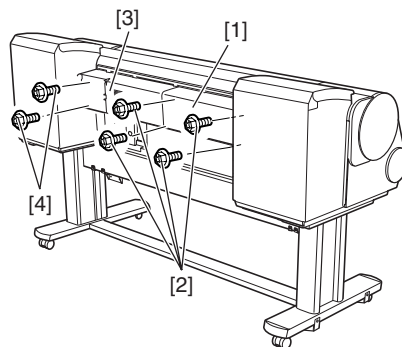

F-4-16

h) Lower rear cover, right/ left, filter cover

Removing the lower rear cover, right/ left, filter cover

- 1) To remove lower rear cover, right [1], remove four screws [2].
- 2) To remove lower rear cover, left [3], remove two screws [4].
- 3) To remove filter cover [5], remove screw [6].

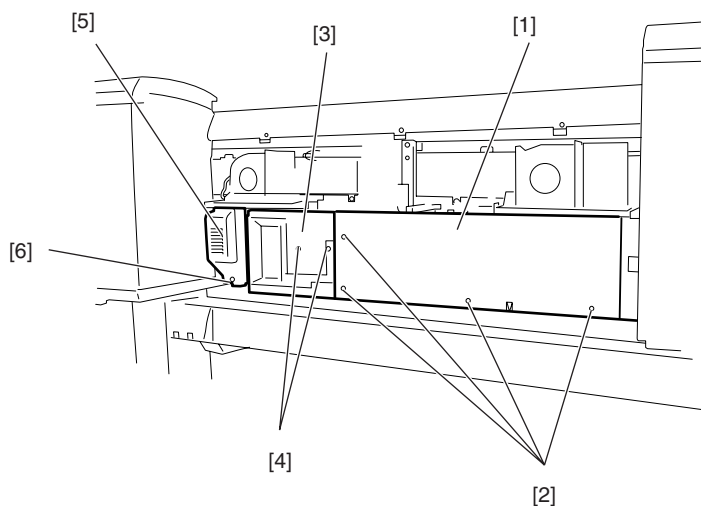

F-4-17

i) Left/ right ink tank cover units

Removing the left/ right ink tank cover units

- 1) To remove left/ right ink tank cover unit [1], remove three screws [2], open tank cover [3] and remove two hooks [4].

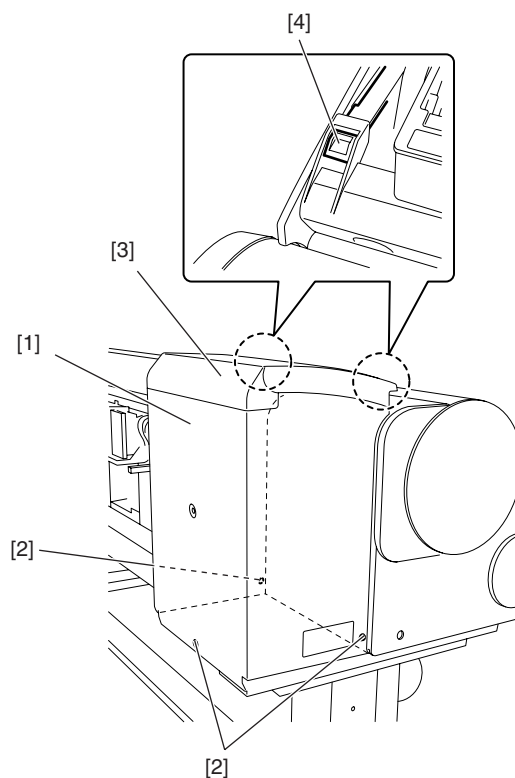

F-4-18

j) Ink tank units

Opening the ink tank units

- 1) To open the left/right ink tank units, remove left/ right circle cover (L), left/ right circle cover (S), left/ right side covers, upper left/ right cover and left/ right ink tank cover unit.
- 2) Remove two screws [1].
- 3) Remove screw [2] from the support plate at inner side of the printer.
- 4) Remove screw [4] from the support plate [3] at outer side of the printer, loosen screw [5] and slide the support plate to open the ink tank unit.

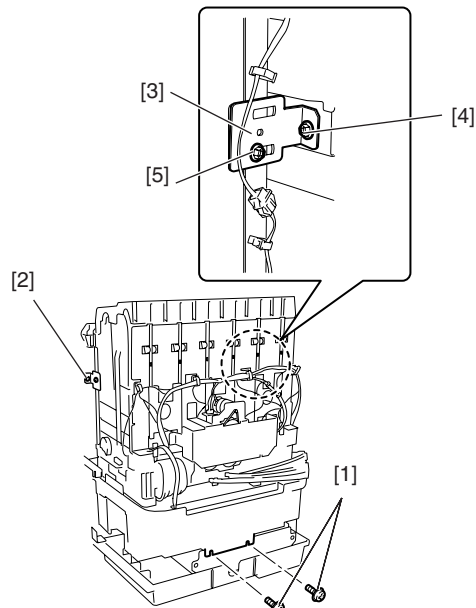

F-4-19



The ink tank units will lock themselves when they are opened to the maximum allowable angle. Be sure to open the ink tank unit to their maximum allowable angle to prevent them from turning over.

k) Upper rear cover

Removing the upper rear cover

- 1) To remove the upper rear cover, remove left/ right circle cover (L), left/ right circle cover (S), left/ right side covers , upper left/upper right cover, rear cover, right/ left , and left/ right ink tank cover units and then open the left/ right ink tanks.
- 2) Remove two screws [1] on front side of the printer and three screws [2] on the rear side, and then remove upper rear cover [3].

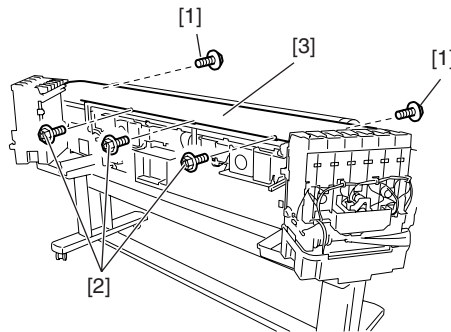

F-4-20

Note on installing the upper rear cover

- 1) Fit three rear-panel screws [1] into screw holes on the right side.

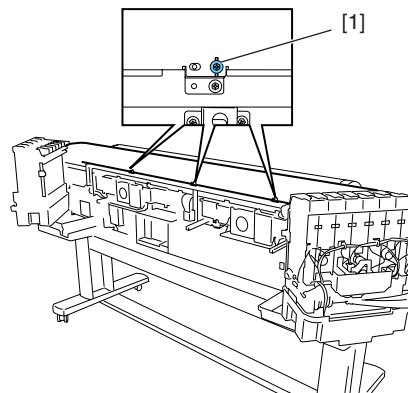

F-4-21

l) Upper cover

Removing the upper cover

- 1) To remove the upper cover, remove left/ right circle covers (L), left/ right circle covers (S), left/ right side covers , upper left/upper right covers, rear cover left/ right , right cover unit and upper rear cover.
- 2) Remove upper cover [2] while opening left/right arm stays [1] outward one by one.

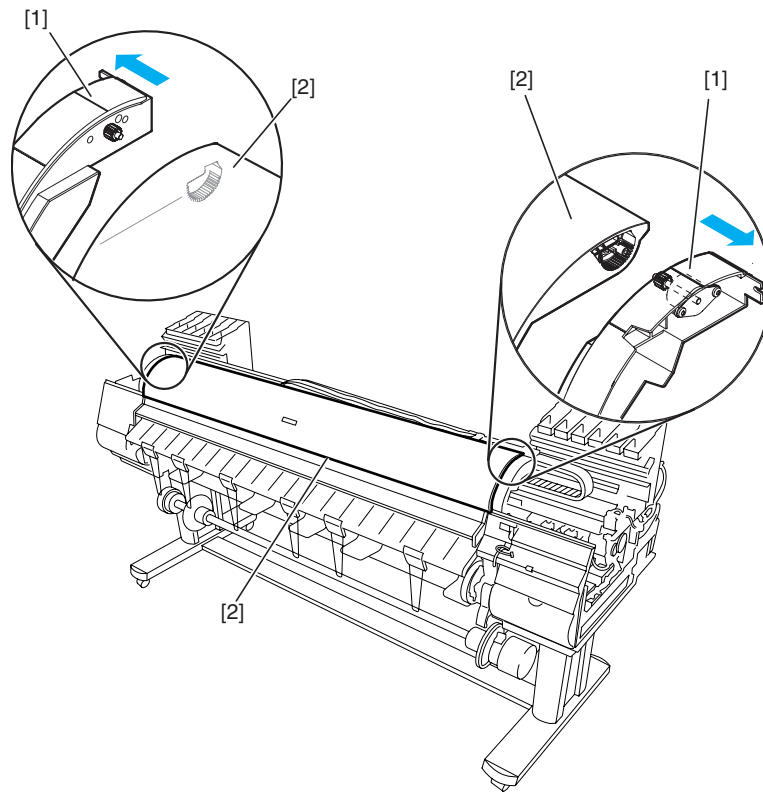

F-4-22

m) Release lever

Removing the release lever

- 1) To remove release lever [1], remove the purge unit and then remove the release lever. To do so, keep pinch roller [2] pressurized to ease to work of phase alignment during gear installation.

Reinstalling the release lever

- 1) To install the release lever, align the gear of the release lever with mark [3] (phase) in the receiving gear.

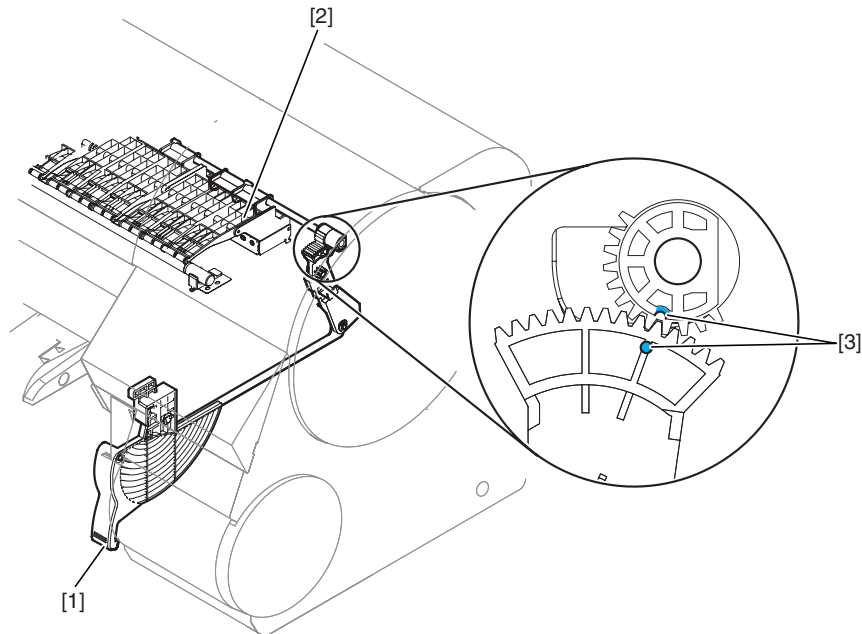

F-4-23

4.3.5 Drive unit

a) Feed motor

Removing the feed motor

- 1) To remove feed motor [1], loosen four screws [2] and remove timing belt [3] and spring [4].
- 2) Remove four loosened screws [2] to release feed motor [1] and remove the connector.

Reinstalling the feed motor

To reassemble the feed roller drive timing belt [3] into position, set the tension of timing belt [3] by adjusting the pressure of spring [4]. Then, fix feed motor [1].

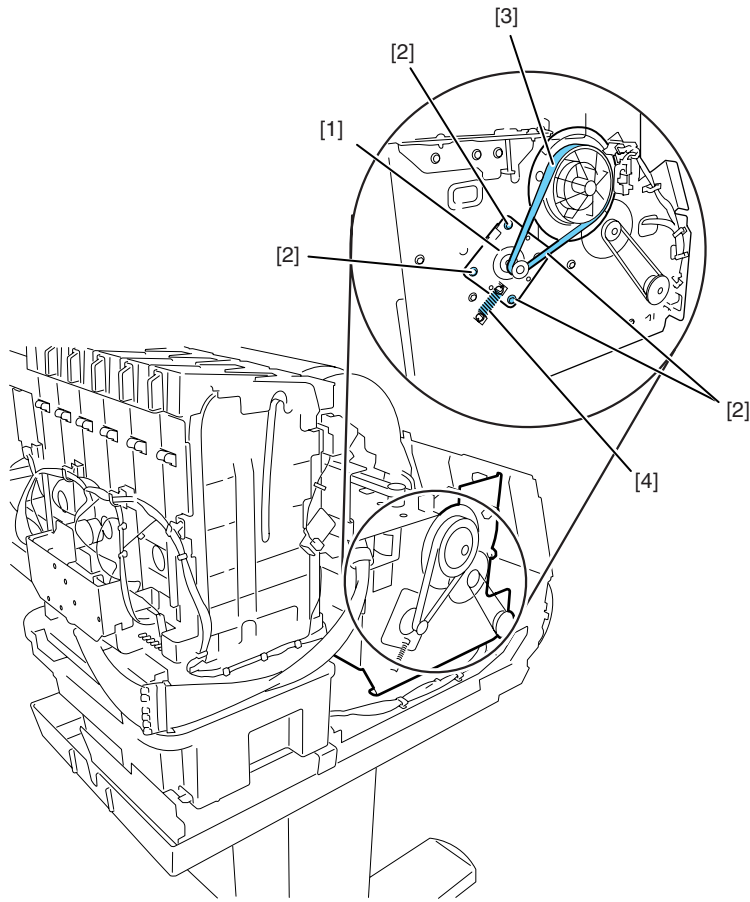

F-4-24

b) Action to take after replacing the feed roller HP sensor, feed roller encoder and feed roller

This printer as shipped has the feed roller eccentricity (that is, variations in the rate of paper feed from rotation to rotation) corrected for enhanced media feed accuracy. When the feed roller HP sensor or feed roller encoder and feed roller pertaining to the correction of eccentricity variations has been replaced, therefore, they should require adjustment.

Execute service mode under the following conditions to launch automatic adjustment:

Service mode: SERVICE MODE > ADJUST > PRINT PATTERN > LF TUNING

Media type: Glossy photo paper

4.3.6 Carriage unit

a) Removing the carriage unit

1) Drain the ink. See Disassembly/Reassembly > Points to Note on Disassembly/Reassembly > Draining the ink.

2) Turn off the power and move the carriage to above the platen. If the carriage is locked at its home position, insert a Phillips screwdriver from the right side into hole [1] in the shaft of the lifting unit in the purge unit and turn it counterclockwise. This will lower cap [2] and lock pin [3], allowing the carriage to be moved.

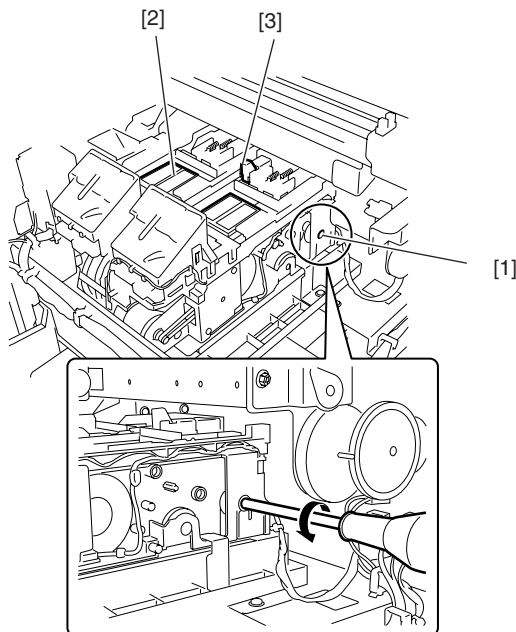

F-4-25

3) Remove the printheads.

4) Release the ink tube from the guide, detach four link levers [1] from the printhead fixer lever, than remove two joint bases [2].

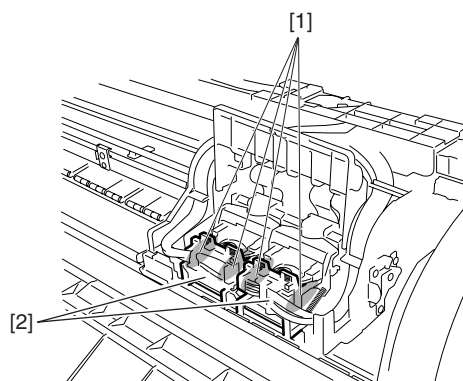

F-4-26

5) Remove two screws [1] and ink tube cover [2].

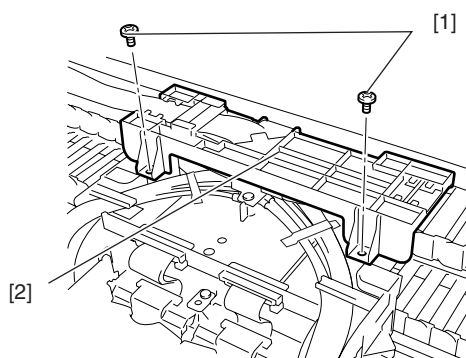

F-4-27

6) Detach joints [1] of the ink tube.

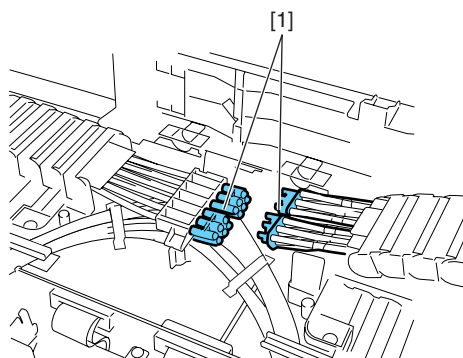

F-4-28

7) Remove four screws [1] and open carriage PCB cover [2].

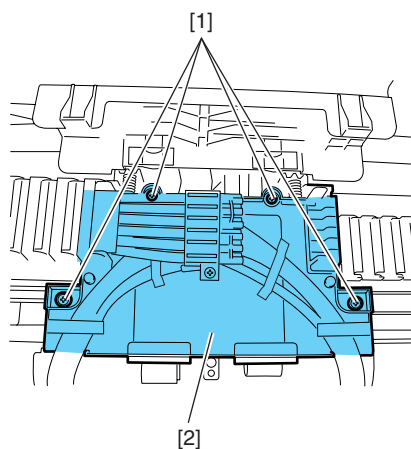

F-4-29

8) Disconnect five flexible cables from the carriage relay PCB.

9) Cover the joint of the ink tube unit in a plastic bag or the like to prevent ink splashing and leakage, and seal the mouth of the bag.



Never peel off tape [1] that fixes the ink tube when detaching the joints of the ink tube on the upper part of the carriage or when removing the joint base from the carriage.

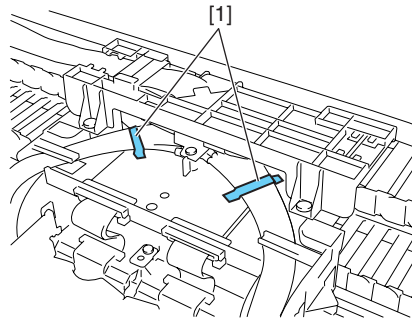

F-4-30

10) Twist off belt fixer knob [1] to loosen the belt, and remove spring [2], guide [3] and pulley [4].

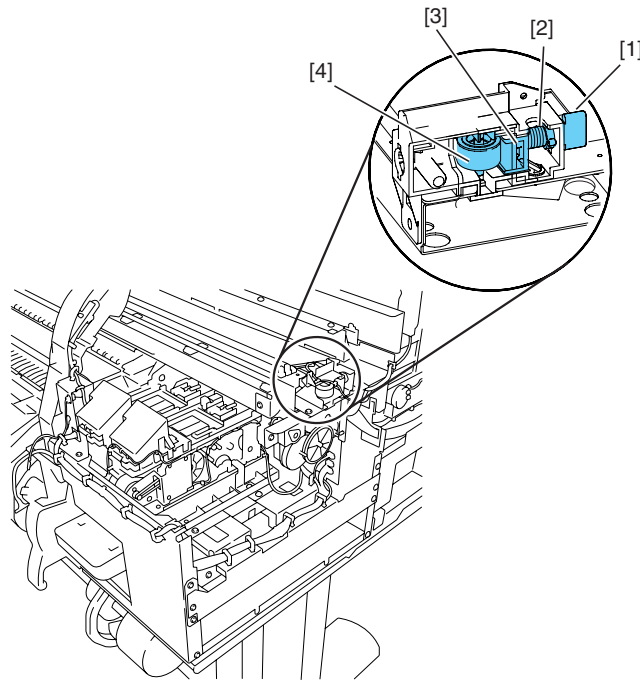

F-4-31

- 11) Release carriage belt from the pulley of the carriage motor.
- 12) Remove two screws [1] and pulley base [2].
- 13) Remove screw [3] and the connector [4] to release head management sensor unit [5].
- 14) Remove five screws [6] and lift unit [7].

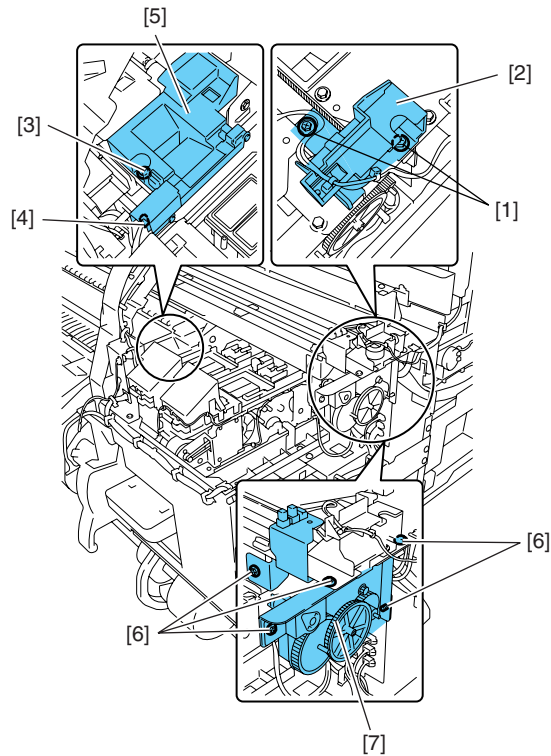

F-4-32

15) Remove the cutter unit, and lay the caterpillar of the ink tube unit on its side, and then remove the carriage from the right side of the printer.



- To remove the carriage unit, pull it out of position keeping the carriage unit level with care not to harm the linear scale. Flaws on the linear scale could result in malfunctioning.

- After detaching the joint of the ink tube unit, the joint might become easy to come off by the ink that has adhered to it. In that case, please wash the joint by alcohol and remove the adhering ink.

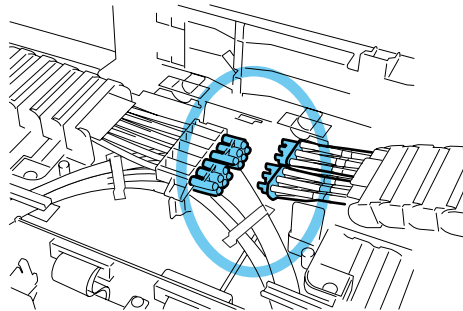

F-4-33

b) Mounting the carriage belt

To install the carriage belt, put in the point of the belt to the interior of the groove [1], and have all the cogs of carriage belt [3] engaged with belt stopper [2].

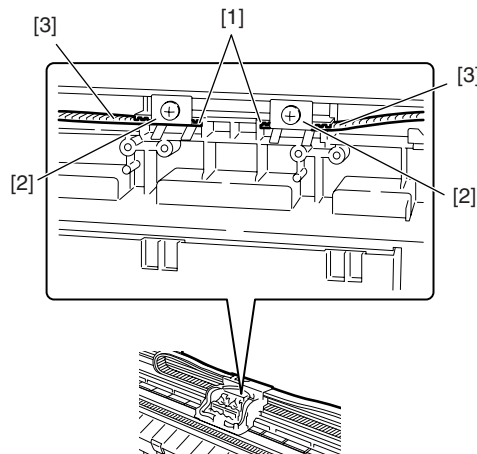

F-4-34

c) Note on replacing the carriage unit and the multi sensor

When either carriage unit or multi sensor has been replaced, be sure to replace the multi sensor reference plate as well.

d) Action to take after replacing the carriage unit and the multi sensor

Because the distance between the multi sensor (in the carriage unit) and the nozzles (in each printhead) is varied from one unit to another, the printer has its optical axis corrected and paper gap adjustment sensor gain and calibration adjusted prior to shipment. When the carriage unit or multi sensor has been replaced, they should require adjustment.

Execute service mode under the following conditions to launch automatic adjustment:

1) Optical axis correction

- Service mode: SERVICE MODE > ADJUST > PRINT PATTERN > OPTICAL AXIS

Media type: Gloss photo paper

2) Paper gap adjustment

- Service mode: SERVICE MODE > ADJUST > GAP CALIB

3) Sensor correction for calibration

- Service mode: SERVICE MODE > ADJUST > SENSOR CALIB

4.3.7 Ink tube unit

a) Removing ink tube unit

1) Drain the ink. See Disassembly/Reassembly > Points to Note on Disassembly/Reassembly > Draining the ink.

2) Remove the carriage unit. See Disassembly/Reassembly > Points to Note on Disassembly/Reassembly > Carriage Unit.

3) Disconnect five flexible cables from the main controller PCB.

4) Remove the flexible cable leading to the carriage PCB cover from the guide.

5) Remove three screws [1] and release ink tube fixer base [2] from the frame.

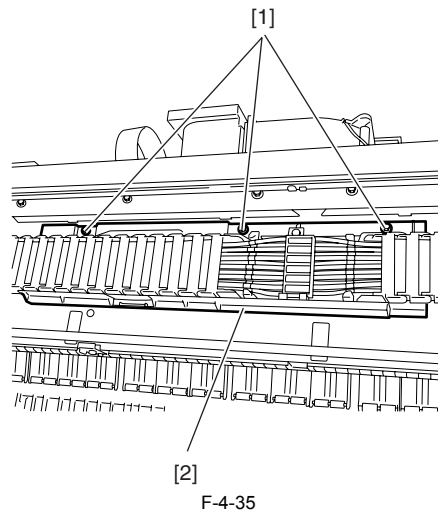

6) Unclamp the ink tube and remove it from the frame with care to avoid ink splashing and contact with the linear scale.



Never peel off tape [1] that fixes the ink tube when detaching the joints of the ink tube on the upper part of the carriage or when removing the joint base from the carriage.

When replacing the ink tube unit, be sure that the tapes [1] are posted to the new ink tube unit.

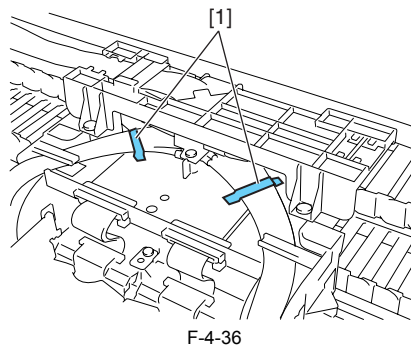

b) Reassembling ink tube units

When the ink tube unit has been replaced, turn on the power without mounting the printhead and the ink tanks.

Then, mount the printhead and ink tanks as directed by message guidance.



After detaching the joint of the ink tube unit, the joint might become easy to come off by the ink that has adhered to it. In that case, please wash the joint by alcohol and remove the adhering ink.

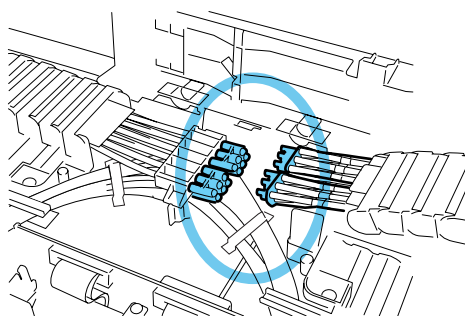

F-4-37

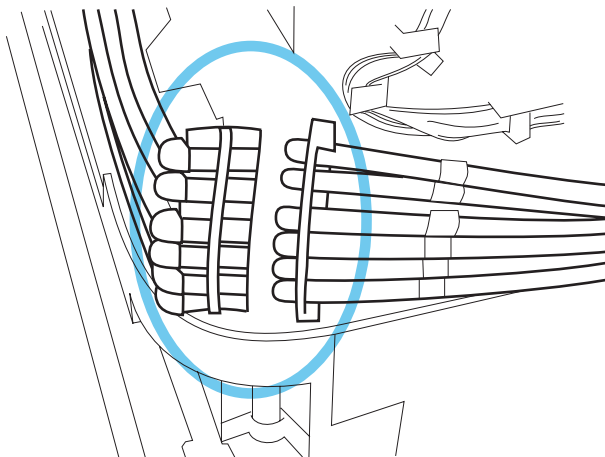

F-4-38

4.3.8 Feeder unit

a) Handling the feed roller



The feed roller is a functionally important part. Therefore, be sure to note the following points when handling the roller.

- Do not hold the roller with one hand or warp its shape.
- Do not touch the roller surface (coated surface).
- Do not allow the roller to get scratched or marked.
- Hold the roller at two points; location D and one of the locations A, B, or C as shown in the figure below.

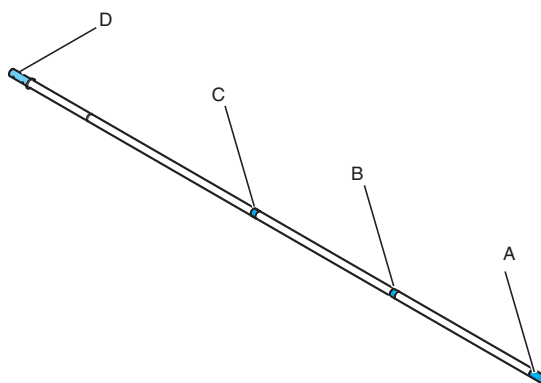

F-4-39

b) Action to take after replacing the feed roller HP sensor, feed roller encoder, or feed roller

Eccentricity of the feed roller is factory-corrected (variation in the paper feed distance per rotation is compensated for) to enhance the media feed accuracy. Therefore, when you have replaced the feed roller HP sensor, feed roller encoder, or feed roller related to correction of feed roller eccentricity, adjustment is required.

Use the service mode under the following conditions:

Service mode: SERVICE MODE > ADJUST > PRINT PATTERN > LF TUNING

Media type: Glossy photo paper

4.3.9 Purge unit

a) Removing the purge unit

- 1) Turn off the power and move the carriage to above the platen. If the carriage is locked at its home position, insert a Phillips screwdriver from the right side into hole [1] in the shaft of the lift unit in the purge unit and turn it counterclockwise. This will lower cap [2] and lock pin [3], allowing the carriage to be moved.

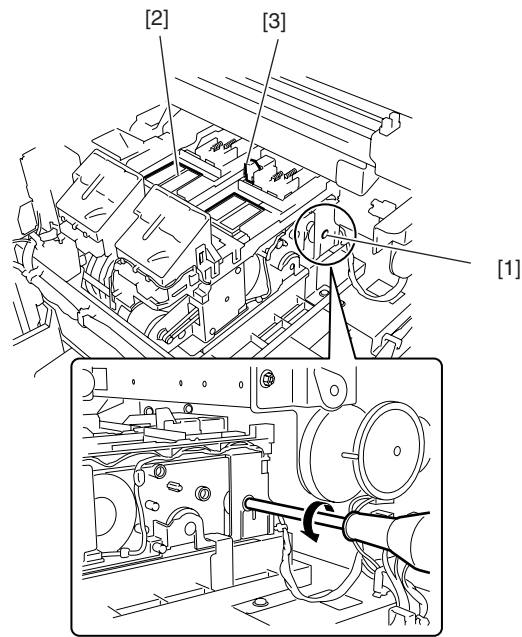

F-4-40

2) Remove connector [1] and three screws [2] and then remove purge unit [3].

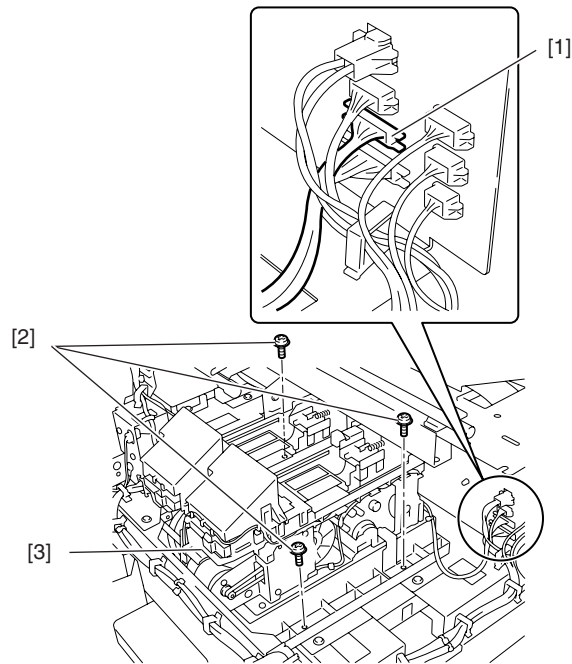

F-4-41

4.3.10 Ink tank unit

a) Removing ink tank units

- 1) Drain the ink. See Disassembly/Reassembly > Points to Note on Disassembly/Reassembly > Draining the ink.
- 2) Detach the joint between the ink tube unit and ink tank unit [1].
- 3) Remove four screws [2] and five connectors [3] and then remove the ink tank unit.

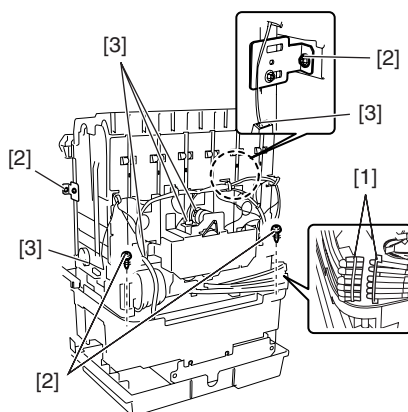

F-4-42



After detaching the joint between the ink tube unit and the ink tube of the ink tank unit, the joint might become easy to come off by the ink that has adhered to it. In that case, please wash the joint by alcohol and remove the adhering ink.

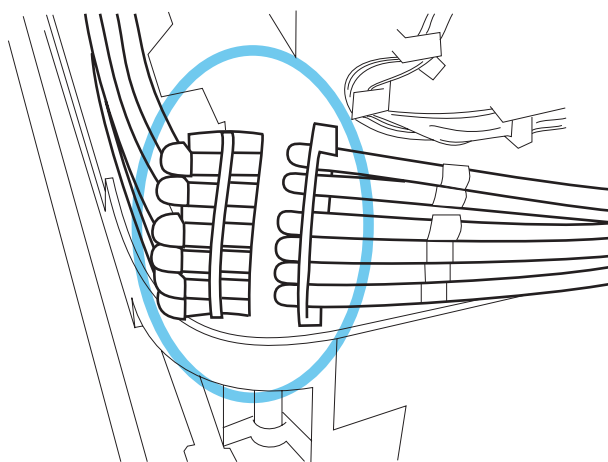

F-4-43

b) Reinstalling ink tank units

The left and right ink tank units are installed to different positions at waste ink tray [1].

Install the right ink tank unit at screw position [2].

Install the left ink tank unit at screw position [3].

(Installing position of each ink tank units are inner side of the printer.)

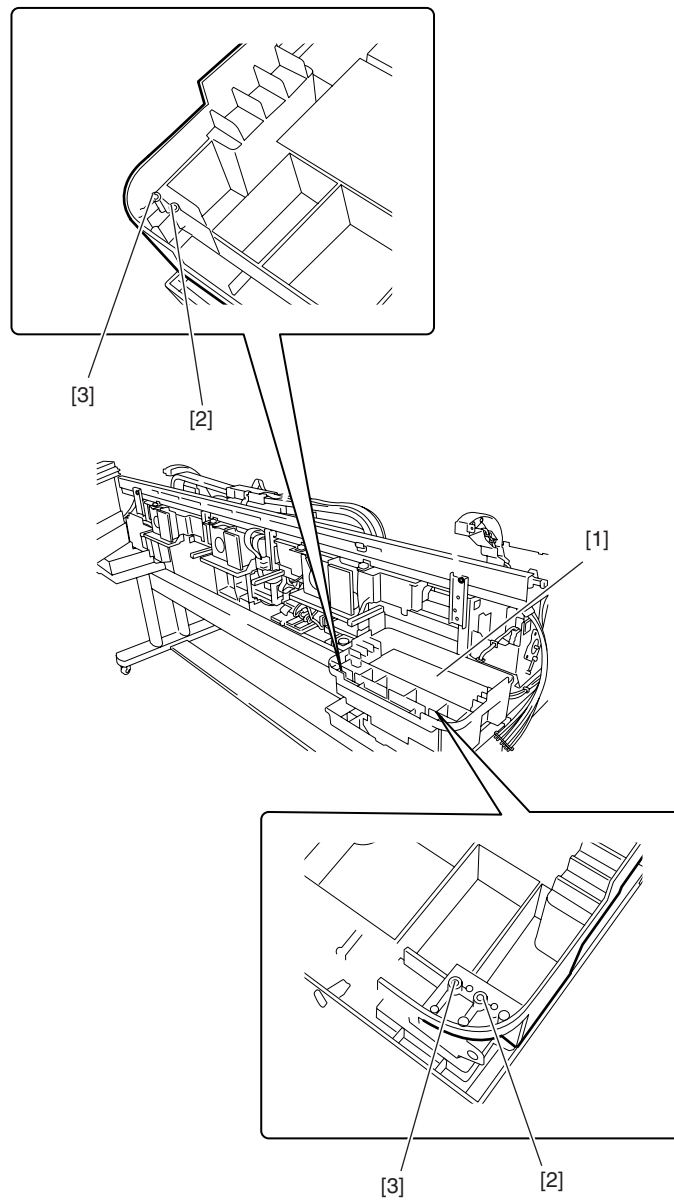

F-4-44

c) Removing the valve motor unit

- 1) To remove the valve motor unit, remove the ink tank cover unit.
- 2) Remove three screws [1], two connectors [2] and bearing [3], and then remove valve motor unit [4].

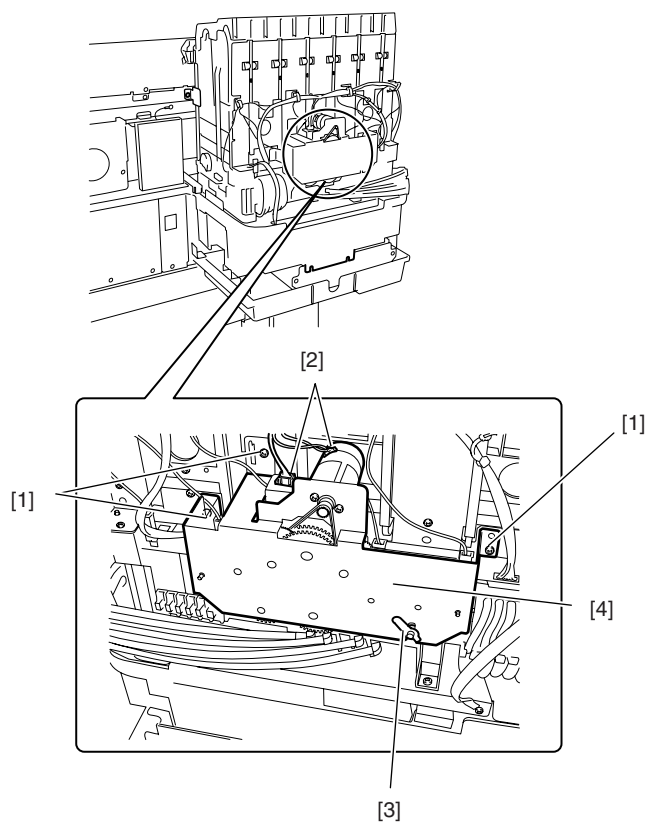

F-4-45

4.3.11 Linear encoder

a) Removing the linear encoder

- 1) Move the carriage to above the platen.
- 2) Remove two screws [1] and upper rear stay [2].

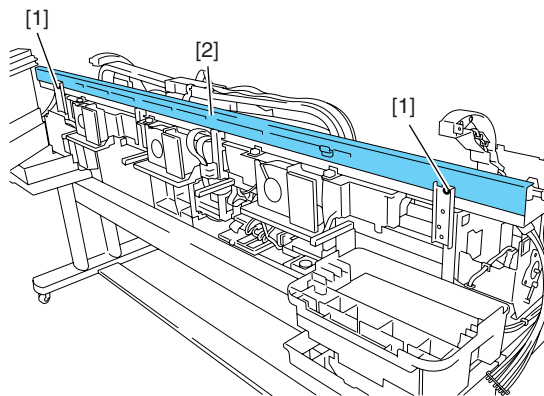

F-4-46

- 3) Remove two screws [1] and linear encoder [2].

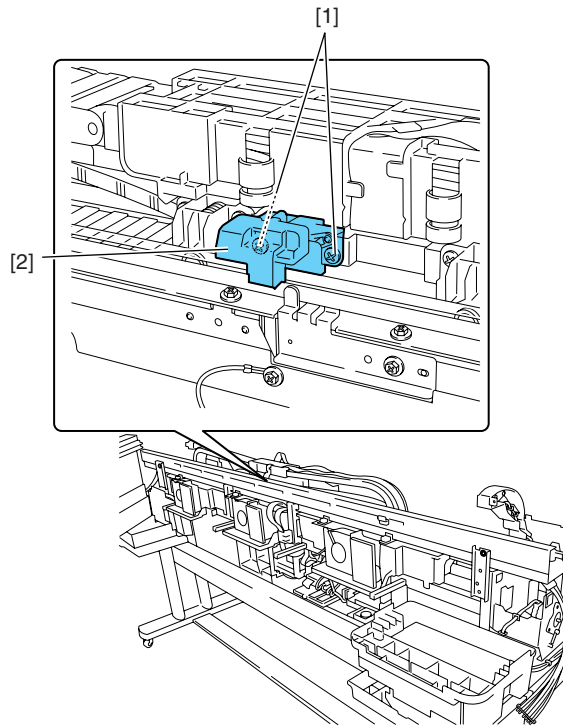

F-4-47

4.3.12 Head management sensor

a) Removing the head management sensor

1) To remove head management sensor [1], remove screw [2] and disconnect connector [3].

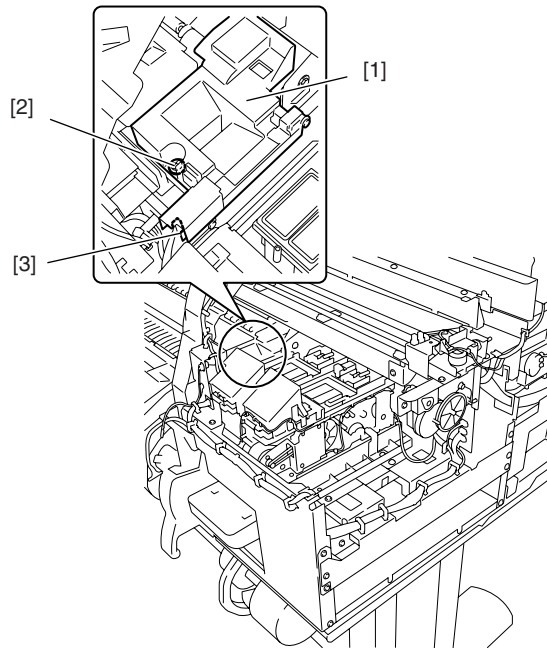

F-4-48

b) Action to take after replacing the head management sensor

Because the distance between the head management sensor and the carriage unit is varied from one unit to another, the printer has its optical axis corrected to adjust the non-discharging nozzle detection position prior to shipment. When the head management sensor carriage unit has been replaced, it should require adjustment. Execute service mode under the following conditions:

SERVICE MODE > ADJUST > NOZZLE CHK POS

4.3.13 PCBs

Do not replace the main controller PCB and the maintenance cartridge relay PCB (ROM board) at the same time.

Both PCBs hold vital information, such as settings and a carriage drive time. Before either PCB is replaced, such information is temporarily saved through internal communication with the other PCB and is automatically written to the new PCB when it is installed. For this reason, the two PCBs cannot be replaced at the same time. To replace both PCBs, work in order of (a) > (b).

When the main controller PCB and maintenance cartridge relay PCB have been replaced with service parts, check that the latest version of firmware is installed in them.

If not, upgrade the firmware to the latest version.

a) Replacing the maintenance cartridge relay PCB (ROM board)

1) Turn off the power and disconnect the power plug.

- 2) Replace the maintenance cartridge relay PCB.
- 3) Reconnect the power plug and turn on the power while pressing the [Paper Source] and [Information] keys. (Start the printer in PCB replacement mode.)
- 4) Release the key, but not before making sure that "Initializing" appears on the display. (The message lamp lights when printer enters PCB replacement mode.)
- 5) Wait until "REPLACE MODE" appears on the display.
- 6) Select MC BOARD and press the [OK] key.
- 7) Turn off the power, but not before making sure that "Power off" appears on the display.
- 8) Turn on the power.
- 9) Check the firmware version. If the firmware is not the latest version, upgrade the firmware to the latest version.

b) Replacing the main controller PCB

- 1) Turn off the power and disconnect the power plug.
- 2) Replace the main controller PCB.
- 3) Reconnect the power plug and turn on the power while pressing the [Paper Source] and [Information] keys. (Start the printer in PCB replacement mode.)
- 4) Release the key, but not before making sure that "Initializing" appears on the display. (The message lamp lights when printer enters PCB replacement mode.)
- 5) Wait until "REPLACE MODE" appears on the display.
- 6) Select CPU BOARD and press the [OK] key.
- 7) Turn off the power, but not before making sure that "Power off" appears on the display.
- 8) Turn on the power.
- 9) Check the firmware version. If the firmware is not the latest version, upgrade the firmware to the latest version.

4.3.14 Opening the cap and moving the wiper unit

This section explains how to uncap the carriage and ink supply valves manually.

Moving carriage when the power of the printer is off, releasing carriage lock pin and uncapping must be done manually.

1. Uncapping, releasing the carriage lock pin and moving the wiper unit

- 1) Remove right circle cover (L), right circle cover (S), right side covers and upper right cover.
 - 2) Insert a Phillips screwdriver from the right side into hole [1] in the shaft of the lift unit in the purge unit and turn it counterclockwise. This will lower cap [2] and lock pin [3], allowing the carriage to be moved.
- The wiper unit will move in sync with the motion of the cap and lock pin.

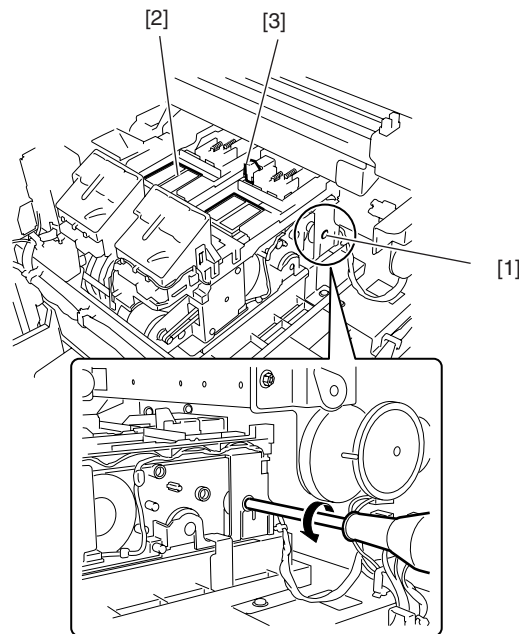

F-4-49

4.3.15 Opening and closing ink supply valves

a) Opening and closing ink supply valves

- 1) Remove the ink tank cover unit.
- 2) Press valve lever [1] with a finger to open the ink supply valve.

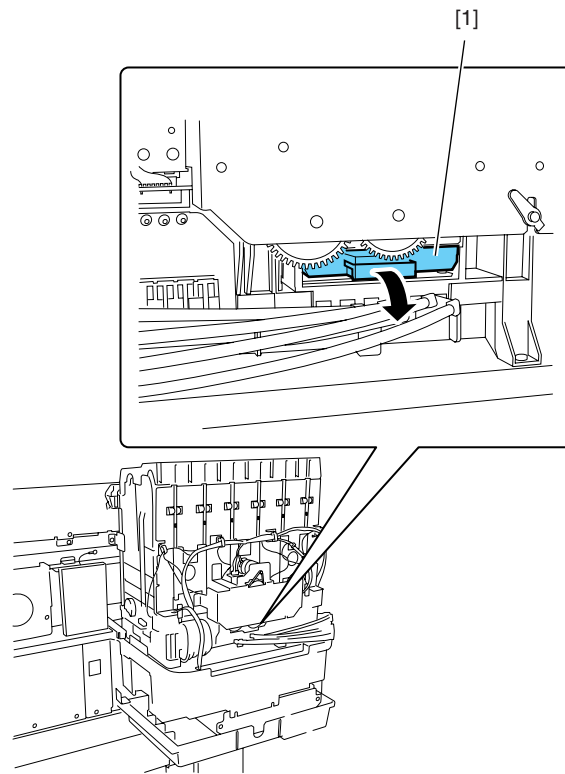

F-4-50



- If the printhead fixer lever is released with the ink supply valve to an ink tube open while the tube is filled with an ink, the ink in the tube could flow backward to the ink tank unit, leaking through the hollow needle in the ink tank.
- If an ink supply valve remains open, as on occurrence of an ink supply valve open/close error, remove the valve motor unit and (see Disassembly/Reassembly > Points to Note on Disassembly/Reassembly > Ink Tank Units) and close the ink supply valve.

4.3.16 Draining the ink

There are two ways to drain the ink passage of inks: automatic and manual.



Be sure to drain the ink from the ink passage to prevent ink leakage before disassembling any component of the ink passage or reshipping the printer.

1. Automatic Ink Drain

Execute Automatic Ink Drain by selecting Maintenance > Move Printer from the main menu.



Execute Automatic Ink Drain once again if the printer shuts down due to a power failure or any other trouble before the operation completes.

2. Manual Ink Drain

Drain the ink passage of inks manually if any electrical component in the printer fails or firmware malfunctions or if the printer fails to be powered on.

- 1) Remove right circle cover (L), right circle cover (S), right side covers, left/ right the ink tank cover units. See Disassembly/Reassembly > Points to Note on Disassembly/Reassembly > External Covers.
- 2) Remove the ink tanks.
- 3) Move the carriage to above the platen. See Disassembly/Reassembly > Points to Note on Disassembly/Reassembly > Opening the caps and moving the wiper unit.
- 4) Release the printhead fixer lever.
- 5) Open the ink supply valves to allow the inks to flow into the sub tanks.

3. Draining the ink in sub tanks

- 1) Remove ink discharge tube [1] behind each sub tank and move the ink from the sub tank into a container. Repeat this procedure for each additional sub tank.

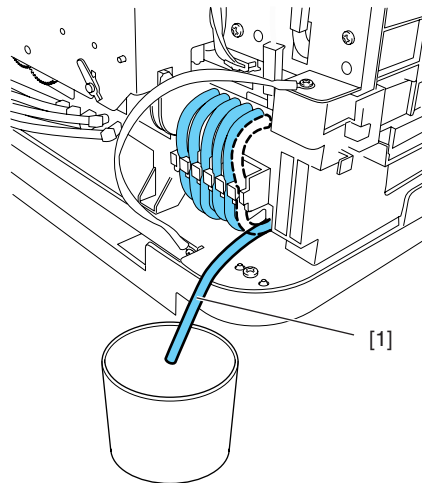

F-4-51

4.4 Applying the Grease

4.4.1 Applying the Grease

Apply the grease at the location shown below.
Smear the grease lightly and evenly with a flat brush.



Don't apply the grease to locations other than those designated. Unwanted grease may cause poor print quality, take particular care that grease does not get onto the wiper, cap, or the linear scale.

T-4-1

No.	Place	Kind	Quantity	Note
1	The joint base rail and rib of carriage unit	Molykote PG-641	Smear the grease lightly	
2	Two feed roller backup	Permalub G No.2	approx.12mg	Don't apply to central backup with bearing.
	Bushing	Permalub G No.2	Smear the grease lightly	
3	Feed roller bearing	Permalub G No.2	approx.24mg	Apply if remove bearing from a feed roller.
4	Pinch roller release cam three points x 10 parts	Permalub G No.2	Smear the grease lightly	
5	Upper cover stay shaft hole	Permalub G No.2	approx.24mg	
	The gear shaft of the upper cover stay gear	Permalub G No.2	approx.24mg	
	Upper cover stay shaft end	Permalub G No.2	approx.24mg	
	The gear tooth face of upper cover stay	Permalub G No.2	Smear the grease lightly	

1. The joint base rail [1] and the rib [2] of the carriage unit.

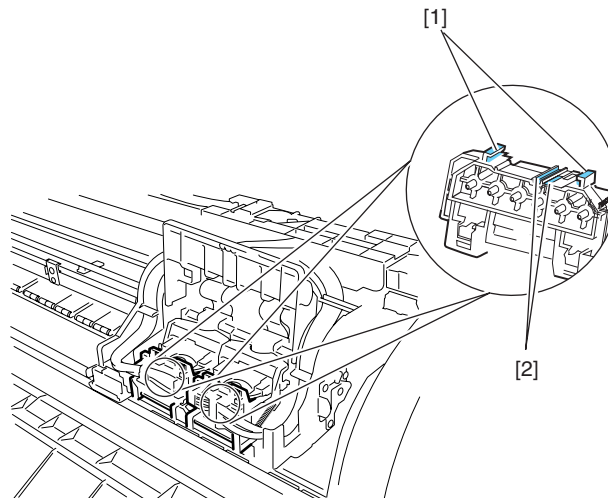

F-4-52

2. Two feed roller backup [1]/ bushing [2]
3. Feed roller bearing [3]

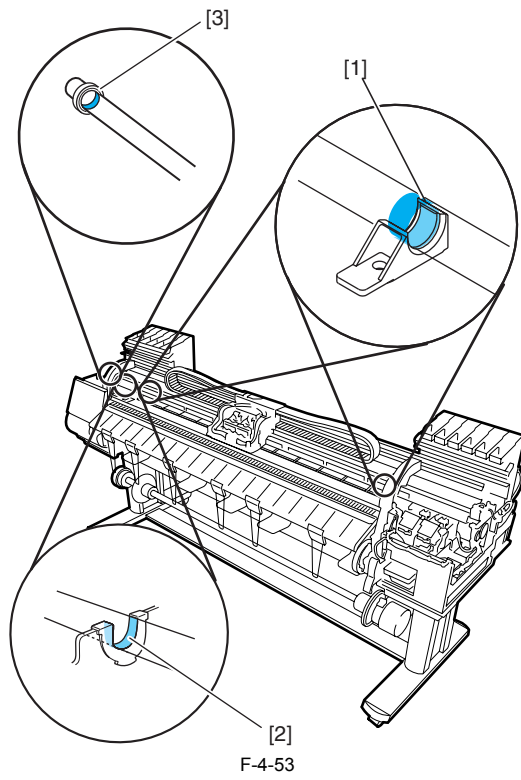

4. Pinch roller release cam [1] three points x 10 parts

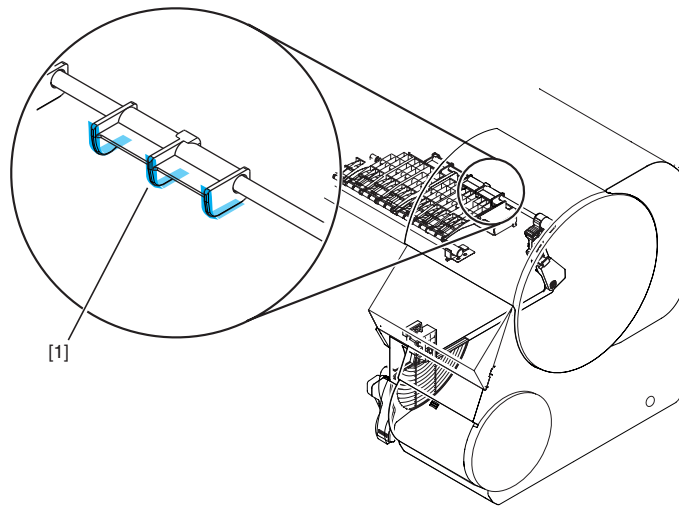

5. Upper cover stay shaft hole [1]/ gear shaft [2]/ shaft end [3]/ gear tooth face [4]

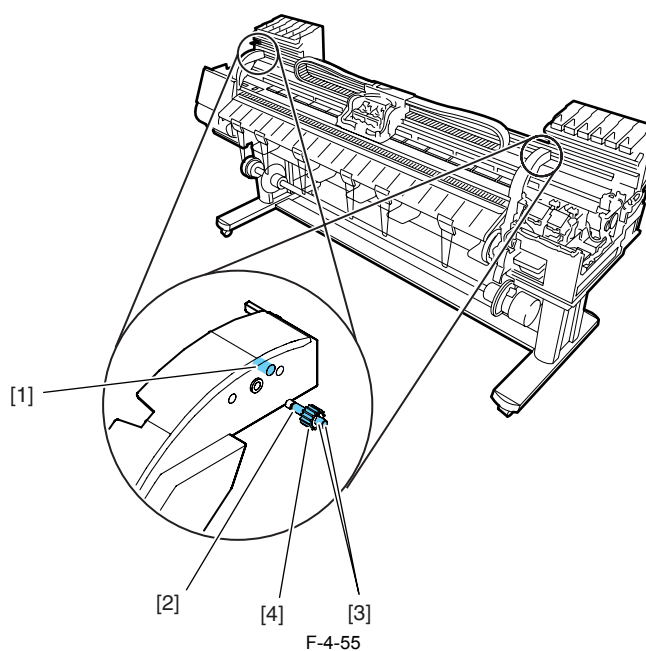

4.5 Adjustment and Setup Items

4.5.1 Action to take after replacing the feed roller HP sensor, feed roller encoder, or feed roller

Action to take after replacing the feed roller HP sensor, feed roller encoder or feed roller

Feed roller eccentricity is factory-adjusted (correction of variation in the paper feed amount per rotation). It is necessary to adjust feed roller eccentricity after replacing the feed roller HP sensor, feed roller encoder or feed roller.

In the service mode, perform automatic adjustment of feed roller eccentricity.

Service mode : SERVICE MODE > ADJUST > PRINT PATTERN > LF TUNING

Media type : Photo glossy paper

4.5.2 Action to take after replacing the carriage unit or multi sensor

a) Note on replacing the carriage unit and the multi sensor

The multi sensor reference plate must be replaced at the same time whenever the carriage or the multi sensor is being replaced.

b) Multi Sensor Recalibration

Because the distance between the multi sensor (in the carriage unit) and the nozzles (in each printhead) is varied from one unit to another, the printer has its optical axis corrected and paper gap adjustment sensor gain and calibration adjusted prior to shipment. When the carriage unit or multi sensor has been replaced, they should require adjustment.

Execute service mode under the following conditions to launch automatic adjustment:

1) Optical axis correction

- Service mode: SERVICE MODE > ADJUST > PRINT PATTERN > OPTICAL AXIS

Media type: Gloss photo paper

2) Paper gap adjustment

- Service mode: SERVICE MODE > ADJUST > GAP CALIB

3) Sensor correction for calibration

- Service mode: SERVICE MODE > ADJUST > SENSOR CALIB

4.5.3 Action to take after replacing the head management sensor

Since the distance between the head management sensor and the carriage unit varies among printers, the optical axis is factory-adjusted to adjust the non-discharging detection position. When you have replaced the head management sensor or performed assembly/reassembly of surrounding parts that can change the distance between the head management sensor and the carriage unit, readjustment is required

Perform the readjustment in the service mode.

Service mode : SERVICE MODE > ADJUST > NOZZLE CHK POS.

Chapter 5 MAINTENANCE

Contents

5.1 Periodic Replacement Parts	5-1
5.1.1 Periodic replacement parts	5-1
5.2 Consumable Parts.....	5-1
5.2.1 Consumable parts.....	5-1
5.3 Periodic Maintenance.....	5-1
5.3.1 Regular Maintenance	5-1

5.1 Periodic Replacement Parts

5.1.1 Periodic replacement parts

T-5-1

Level	Periodic Replacement part
User	None
Service Personnel	None

5.2 Consumable Parts

5.2.1 Consumable parts

T-5-2

Level	Consumables			Life sheets/A0	Parts Counter	
	Name	Part number	Q'ty		Parts	Unit
User	See "Specifications > Features > Consumables"					
Service	WASTE INK ABSORBER UNIT	QL2-2110	1	20000	A1	A
	WASTE INK ABSORBER UNIT (L)	QL2-2108	2	20000	A3, A4	
	WASTE INK ABSORBER UNIT (S)	QL2-1650	1	20000	A5	
	SUCTION FAN UNIT	QM3-1012	1	20000	A6	
	DUCT	QL2-1663	1	20000	A6	
	CARRIAGE UNIT	QM3-1995	1	20000	D1, D2, D3	D
	TUBE UNIT	QM3-2004	1	20000	D4	
	PURGE UNIT	QM3-1004	1	20000	H1	H
	SENSOR UNIT	QM3-1056	1	20000	K1	K
	MOTOR, CARRIAGE	QK1-2868	1	20000	M1	M
	FEED MOTOR ASS'Y	QM2-2502	1	20000	P1	P
FAN UNIT	QM3-1038	2	20000	V1	V	

5.3 Periodic Maintenance

5.3.1 Regular Maintenance

T-5-3

Level	Regular maintenance
User	Cleaning of ink mist and other substances (When necessary and when replacing the printhead)
Service personnel	None

Chapter 6 TROUBLESHOOTING

Contents

6.1 Troubleshooting	6-1
6.1.1 Outline.....	6-1
6.1.1.1 Outline of Troubleshooting.....	6-1
6.1.2 Troubleshooting When Warnings Occur	6-1
6.1.2.1 Ink Level: Check	6-1
6.1.2.2 Check maint cartridge capacity.....	6-1
6.1.2.3 Ink tank is empty. Replace the ink tank.....	6-1
6.1.2.4 No ink tank loaded. Check ink tank.....	6-1
6.1.2.5 Close Ink Tank Cover	6-1
6.1.2.6 End of paper feed. Cannot feed paper more.....	6-2
6.1.2.7 Paper Type Wrong	6-2
6.1.2.8 GARO W12xx.....	6-2
6.1.2.9 Check printed document.....	6-2
6.1.2.10 Prepare for parts replacement. Call for service.....	6-2
6.1.2.11 Parts replacement time has passed. Call for service.....	6-3
6.1.3 Troubleshooting When Errors Occur	6-3
6.1.3.1 03870001-2015 Cutter error.....	6-3
6.1.3.2 03010000-200C/03010000-200E/03010000-200F/03010000-2017/03010000-2018/03016000-2010 multi sensor	6-3
6.1.3.3 03031000-2E0F Upper cover sensor error.....	6-3
6.1.3.4 03031101-2E10 Ink tank cover switch error.....	6-3
6.1.3.5 03031000-2E11 Carriage cover sensor error	6-4
6.1.3.6 03031000-2E12 Defective paper release lever	6-4
6.1.3.7 03010000-2016/03010000-2E27 Paper feed error.....	6-4
6.1.3.8 03010000-200D Cut media end error	6-4
6.1.3.9 03010000-2E1F/03060000-2E14/03060A00-2E00/03061000-2E15/03063000-2E08/03860002-2E02/03860002-2E0A/03860002-2E0C Path mismatch error	6-5
6.1.3.10 03862000-2E09 Insufficient roll media error	6-5
6.1.3.11 03890000-2920 Media take-up motor error.....	6-5
6.1.3.12 03890000-2921 Media take-up paper detection sensor error.....	6-5
6.1.3.13 03060A00-2E1B Roll media end error	6-5
6.1.3.14 03861001-2405/03861001-2406 Borderless printing error	6-6
6.1.3.15 03810104-2500/03810101-2501/03810102-2502/03810103-2503/03810112-2504/03810113-2505/03810106-2506/03810105-2508/ 03810115-2509/03810107-250A/03810109-250B/03810108-250C No ink error	6-6
6.1.3.16 03830104-2520/03830101-2521/03830102-2522/03830103-2523/03830112-2524/03830113-2525/03830106-2526/03830105-2528/ 03830115-2529/03830107-252A/03830109-252B/03830108-252C Ink tank is not installed. (This error occurs when the ink tank is replaced.).. 6-6	
6.1.3.17 03800204-2540/03830201-2541/03830202-2542/03830203-2543/03830212-2544/03830213-2545/03830206-2546/03830205-2548/ 03830215-2549/03830207-254A/03830209-254B/03830208-254C Invalid ink tank ID	6-6
6.1.3.18 03830304-2560/03830301-2561/03830302-2562/03830303-2563/03830312-2564/03830313-2565/03830306-2566/03830305-2568/ 03830305-2568/03830315-2569/03830307-256A/03830309-256B/03830308-256C Ink tank EEPROM error	6-6
6.1.3.19 03810204-2570/03810201-2571/03810202-2572/03810203-2573/03810212-2574/03810213-2575/03810206-2576/03810205-2578/ 03810215-2579/03810207-257A/03810209-257B/03810208-257C Ink low error (occurs when replacing the printhead).....	6-6
6.1.3.20 03810204-2580/03810201-2581/03810202-2582/03810203-2583/03810212-2584/03810213-2585/03810206-2586/03810205-2588/ 03810215-2589/03810207-258A/03810209-258B/03810208-258C Ink low error (occures when cleaning B is executed).....	6-7
6.1.3.21 03810204-2590/03810201-2591/03810202-2592/03810203-2593/03810212-2594/03810213-2595/03810206-2596/03810205-2598/ 03810215-2599/03810207-259A/03810209-259B/03810208-259C Ink low error (occures when printing).....	6-7
6.1.3.22 03800301-2801/03800201-2802/03800401-2803/03800201-2812/03800302-2809/03800202-280A/03800402-280B/03800202-2813 Printhead error.....	6-7
6.1.3.23 03800101-2800/03800102-2808/03800201-2804/03800202-2807 Printhead installing error	6-7
6.1.3.24 03800501-280D/03800502-280E Defective printhead nozzle	6-8
6.1.3.25 03841201-2816/03841201-2817/03841101-2818/03841001-2819/03841001-281B Maintenance cartridge error	6-8
6.1.3.26 03010000-2820/03010000-2821/03010000-2822/03010000-2823/03130031-2F32/03010000-2F33/ Adjustment error	6-8
6.1.3.27 03130031-260E Gap detection error.....	6-8
6.1.3.28 03130031-260F Gap adjustment error	6-8
6.1.3.29 03130031-2618 VH voltage abnormality error.....	6-9
6.1.3.30 03800500-2F2F/03800500-2F30 Head management sensor error	6-9

6.1.3.31 03130031-2F16 Mist fan error.....	6-9
6.1.3.32 03130031-2F17 Suction fan error.....	6-9
6.1.3.33 03030000-2E21 IEEE1394 Error.....	6-9
6.1.3.34 03130031-2F25 Carriage home position error.....	6-10
6.1.3.35 03130031-2F26/03130031-2F27 Carriage motor error.....	6-10
6.1.3.36 03130031-2F1F/03130031-2F20 Defective sensor in purge unit.....	6-10
6.1.3.37 03130031-2F22/03130031-2F23/03130031-2F2D Purge motor driving error.....	6-10
6.1.3.38 03130031-2F2A Feed roller home position error.....	6-10
6.1.3.39 03130031-2F3A valve open/close error.....	6-10
6.1.3.40 03130031-2F2E Roll media feeding error.....	6-11
6.1.3.41 03130031-2F28 Lift motor time out error.....	6-11
6.1.3.42 03130031-2F13 A/D Converter external trigger output stopped.....	6-11
6.1.3.43 03130031-2F14 ASIC Register cannot be written.....	6-11
6.1.3.44 03900001-4042/03900001-4049 Firmware error.....	6-11
6.1.3.45 E194-4034 Sensor calibration error.....	6-11
6.1.4 Troubleshooting When Service Call Errors Occur.....	6-12
6.1.4.1 E141-4046 Recovery system's count error.....	6-12
6.1.4.2 E144-4047 Supply system's count error.....	6-12
6.1.4.3 E146-4001 Waste ink count full.....	6-12
6.1.4.4 E161-403E/E161-403F Abnormally high head temperature.....	6-12
6.1.4.5 E194-404A Non-discharge detection count error.....	6-12
6.1.4.6 E196-4040/E196-4041/E196-4042/E196-4043/E196-4044/E196-4045 Main controller PCB error.....	6-12
6.1.4.7 E198-401C/E198-401D/E198-401E RTC error.....	6-12
6.2 Location of Connectors and Pin Arrangement.....	6-13
6.2.1 Main controller PCB.....	6-13
6.2.2 Carriage relay PCB.....	6-22
6.2.3 Head relay PCB.....	6-30
6.3 Version Up.....	6-37
6.3.1 Firmware Update Tool.....	6-37
6.4 Service Tools.....	6-38
6.4.1 List of Tools.....	6-38

6.1 Troubleshooting

6.1.1 Outline

6.1.1.1 Outline of Troubleshooting

1. Outline

Troubles subject to troubleshooting are classified into those shown on the display (warning, error, and service call) and those not shown on the display.

The code of warning and error is shown by combining alphanumeric characters of eight digits and four digits.

The code of service call error is shown by the initial character of "E" and combining alphanumeric characters of three digits and four digits.

No code number is displayed when a warning occurs. Selecting [SERVICE MODE] > [DISPLAY] > [WARNING] allows you to check the warning log.

2. Precautions for Troubleshooting

- 1) Check the environmental conditions and the media used for printing.
 - 2) Before performing troubleshooting, make sure that all connectors and cables are connected properly.
 - 3) When servicing the printer with the external cover removed and the AC power supplied, be extremely careful to avoid electric shock and shorting electrical devices.
 - 4) In the following sections, the troubleshooting steps are described such that the component related to the most probable cause of the problem will be repaired or replaced first, being followed by components with less problem probability. If multiple components have the same problem probability, the steps are described beginning with the easiest one.
- After performing each step, check to see if the problem has been resolved by making test prints. If the problem persists, proceed to the next step.
- 5) After completion of the troubleshooting, check that all connectors and cables have been reconnected and screws have been tightened firmly.
 - 6) Whenever you have performed replacement or repair services, make test prints to check whether the problem has been resolved.

6.1.2 Troubleshooting When Warnings Occur

6.1.2.1 Ink Level: Check

<Cause>

The printer has detected that the ink level is below the lower limit (20% of the capacity) by ink dot count.

<Probable fault location>

Ink tank, ink tank unit, or main controller

<Countermeasure>

- 1) Check the ink level.
- 2) Replace the ink tank.
- 3) Check the connector of the ink tank unit.
- 4) Replace the ink tank unit.
- 5) Replace the main controller PCB.

6.1.2.2 Check maint cartridge capacity.

<Cause>

The machine has detected that the maintenance cartridge is nearly full of waste ink (about 80% of the total capacity of the maintenance cartridge).

<Probable fault location>

Maintenance cartridge or main controller

<Countermeasure>

- 1) Maintenance cartridge
- Check [SERVICE MODE] > [COUNTER] > [PRINTER] > [W-INK]. If the free space is nearly at the limit (0%), replace the maintenance cartridge.
- 2) Replace the main controller PCB.

6.1.2.3 Ink tank is empty. Replace the ink tank.

<Cause>

Ink detection sensor has detected that the ink tank is empty.

<Probable fault location>

Ink tank, ink tank unit, main controller PCB

<Countermeasure>

- 1) Replace the ink tank
- 2) Replace the ink tank unit
- 3) Replace the main controller PCB

6.1.2.4 No ink tank loaded. Check ink tank

<Cause>

Ink tank was not detected during printing.

<Probable fault location>

Ink tank, ink tank unit, main controller PCB

<Countermeasure>

- 1) Check the ink tank to see if it is set properly.
- 2) Replace the ink tank.
- 3) Replace the ink tank unit.
- 4) Replace the main controller PCB.

6.1.2.5 Close Ink Tank Cover

<Cause>

The ink tank cover has been opened during printing.

<Probable fault location>

Operation method, ink tank cover switch, ink tank unit, main controller PCB

<Countermeasure>

1) Check the operation method

Make sure to have the ink tank cover closed

2) Visual check

If the ink tank cover is damaged or deformed, replace it.

3) Replace the ink tank unit.

4) Replace the main controller PCB.

6.1.2.6 End of paper feed. Cannot feed paper more.

<Cause>

In the manual feed mode, the main controller detected that the roll media had been fed by the maximum amount.

Maximum backward feed amount: Printing standby position (on the feed roller)

Maximum forward feed amount: Until the media sensor detects absence of roll media.

<Probable fault location>

Media, media sensor, main controller PCB

<Countermeasure>

1) Media check

If there is any damage or break on the media or the media size is not the specified one, replace the media.

2) Media loading position check

If the media loading position is wrong, load the media again.

3) Media sensor

Check for normal operation. If the operation is abnormal, replace the media sensor.

4) Replace the main controller PCB.

6.1.2.7 Paper Type Wrong

* Occurs as a warning when "ON" is selected for "Ignore Mismatch".

<Cause>

The type of the loaded media was different from the media type specified on the driver.

<Probable fault location>

Media, main controller PCB

<Countermeasure>

1) Media check

Load correct media type.

2) Replace the main controller PCB

6.1.2.8 GARO W12xx

Either of the following numbers will be displayed for "xx" (21, 22, 23, 25, 31, 32, 33, 34, 35)

<Cause>

The GARO command in the received data was invalid.

<Probable fault location>

Operation method or main controller

<Countermeasure>

1) Check the operation method and retry printing.

2) Replace the main controller PCB.

6.1.2.9 Check printed document.

<Cause>

The number of non-discharging nozzles has exceeded the number of nozzles that can back up the non-discharging.

<Probable fault location>

Printhead, head management sensor, head relay PCB, carriage relay PCB, main controller PCB

<Countermeasure>

1) Clean the printhead

2) Replace the printhead

3) Replace the head management sensor unit.

4) Select [SERVICE MODE] > [ADJUST] > [NOZZLE CHK POS].

5) Head relay PCB

Check the terminal connected to the printhead. If there is any problem, replace the head relay PCB.

6) Replace the carriage relay PCB

7) Replace the main controller PCB

6.1.2.10 Prepare for parts replacement. Call for service.

<Cause>

Replacing time of the consumable parts are near.

<Probable fault location>

Consumable parts, main controller PCB

<Countermeasure>

1) Consumable parts

Check [SERVICE MODE] > [COUNTER] > [PARTS CNT.]

If there is a COUNTER showing "W1" status (over 90% of the use rate), replace the consumable parts corresponded to the COUNTER.

After replacing the parts, select [SERVICE MODE] > [INITIALIZE] > [PARTS COUNTER] to initialize the counter.

2) Replace the main controller PCB

6.1.2.11 Parts replacement time has passed. Call for service.

<Cause>

The consumable parts need to be replaced.

<Probable fault location>

Consumable parts, main controller PCB

<Countermeasure>

1) Consumable parts

Check [SERVICE MODE] > [COUNTER] > [PARTS CNT.]

If there is a COUNTER showing "W2" status (over 100% of the use rate), replace the consumable parts corresponded to the COUNTER.

After replacing the parts, select [SERVICE MODE] > [INITIALIZE] > [PARTS COUNTER] to initialize the counter.

2) Replace the main controller PCB

6.1.3 Troubleshooting When Errors Occur

6.1.3.1 03870001-2015 Cutter error

<Cause>

The machine has failed the auto cutting of media.

After roll media cutting, the multi sensor could not detect the media end.

<Probable fault location>

Media, multi sensor, cutter unit, head relay PCB, or main controller PCB

<Countermeasure>

1) Manual cut

Cut the media manually with the scissors or cutter.

2) Media check

If the media size is not the specified one, replace the media.

3) Visual check

Remove foreign substances from the cutter unit if any.

If the cutter unit is damaged or deformed, replace it.

4) Replace the multi sensor

5) Replace the main controller PCB

6.1.3.2 03010000-200C/03010000-200E/03010000-200F/03010000-2017/03010000-2018/03016000-2010 multi sensor

<Cause>

When media was fed, the multi sensor could not detect the media width.

When the right edge of media was detected, the multi sensor detected that the media had been loaded at a wrong position.

When the leading edge of media was to be detected, the multi sensor could not detect the leading edge of media.

When media was fed, the multi sensor detected media smaller than the specified size.

When media was fed, the multi sensor detected media larger than the specified size.

When media was fed, the multi sensor detected skew greater than the specified one.

When media was fed, the multi sensor could not detect the right edge of media.

When media was fed, the multi sensor could not detect the left edge of media.

<Probable fault location>

Media, media loading method, paper path, multi sensor, head relay PCB, carriage relay PCB, or main controller PCB

<Countermeasure>

1) Media check

If there is any print or stain in the detection area on the media or the media size is not the specified one, replace the media.

2) Media loading position check

If the media loading position is wrong, load the media again.

3) Visual check

Remove foreign substances from multi sensor if any.

4) Multi sensor

Select [SERVICE MODE] > [DISPLAY] > [SYSTEM] > [SIZE CR] to check the value read by the multi sensor. If the value is wrong, replace the multi sensor.

5) Replace the head relay PCB.

6) Cable continuity check

If continuity of the cable between the head relay PCB and the carriage relay PCB is abnormal, replace the cable.

7) Replace the carriage relay PCB.

8) Cable continuity check

If continuity of the cable between the carriage relay PCB and the main controller PCB is abnormal, replace the cable.

9) Replace the main controller PCB.

6.1.3.3 03031000-2E0F Upper cover sensor error

<Cause>

The upper cover lock switch detected that the upper cover was open with the upper cover locked.

<Probable fault location>

upper cover, upper cover lock switch, upper cover lock, or main controller PCB

<Countermeasure>

1) Visual check

If the upper cover sensor flag or upper cover lock switch is damaged or deformed, replace it.

Remove foreign substances from the upper cover lock if any.

2) Upper cover lock switch

Check the upper cover lock switch for normal operation. If the operation is abnormal, replace the upper cover lock switch.

3) Upper cover lock unit

Check the upper cover lock for normal operation. If the operation is abnormal, replace the upper cover lock unit.

4) Replace the main controller PCB.

6.1.3.4 03031101-2E10 Ink tank cover switch error

<Cause>

During printing, ink tank cover switch has detected the open state of the ink tank.

<Probable fault location>

Operation method, ink tank cover, ink tank cover switch, main controller PCB

<Countermeasure>

- 1) Operation check
Close the ink tank cover surely.
- 2) Replace the ink tank cover unit.
- 3) Replace the main controller unit.

6.1.3.5 03031000-2E11 Carriage cover sensor error

<Cause>

The carriage cover sensor detected that the carriage cover was opened with the upper cover locked.

<Probable fault location>

Operation method, carriage cover sensor, carriage relay PCB, or main controller PCB

<Countermeasure>

- 1) Operation check
Close the carriage cover tightly.
- 2) Visual check
If the carriage cover is damaged or deformed, replace it.
- 3) Carriage cover sensor
check the carriage cover sensor for normal operation. If the operation is abnormal, replace the carriage cover sensor.
- 4) Replace the carriage relay PCB.
- 5) Cable continuity check
If continuity of the cable between the carriage relay PCB and the main controller PCB is abnormal, replace the cable.
- 6) Replace the main controller PCB.

6.1.3.6 03031000-2E12 Defective paper release lever

<Cause>

The pressure release switch detected that the paper release lever was opened with the upper cover locked.

<Probable fault location>

Operation method, pressure release switch, or main controller PCB

<Countermeasure>

- 1) Operation check
Close the paper release lever fully.
- 2) Visual check
If the paper release lever is damaged or deformed, replace it.
- 3) Pressure release switch
check the pressure release switch for normal operation. If the operation is abnormal, replace the pressure release switch.
- 4) Replace the main controller PCB.

6.1.3.7 03010000-2016/03010000-2E27 Paper feed error

<Cause>

During paper feed or delivery, paper jammed or paper was fed improperly.
During printing, paper was fed out of the way.
During paper feed, delivery or printing, the feed motor has gone out of synchronization.

<Probable fault location>

Paper path, media sensor, feed roller encoder, feed roller HP sensor, feed motor, feed roller, or main controller PCB

<Countermeasure>

- 1) Visual check
Remove foreign substances from the paper path and media sensor if any.
If the paper feed surface or moving part of the paper path is damaged or deformed, replace the paper path.
- 2) Media sensor
Check for normal operation. If the operation is abnormal, replace the media sensor.
- 3) Replace the feed roller sensor unit
Check for normal operation. If the operation is abnormal, replace the feed roller sensor unit.
- 4) Replace the feed motor.
- 5) Replace the feed roller.
- 6) Replace the main controller PCB.

6.1.3.8 03010000-200D Cut media end error

<Cause>

When cut media was fed by the specified length, the media sensor could not detect the trailing edge of the cut media.
During printing, the media sensor detected the trailing edge of the cut media at the position different from that detected during cut media feed.

<Probable fault location>

Paper path, media sensor, feed roller encoder, feed roller HP sensor, feed motor, feed roller, or main controller PCB

<Countermeasure>

- 1) Visual check
Remove foreign substances from the paper path and media sensor if any.
If the paper feed surface or moving part of the paper path is damaged or deformed, replace the paper path.
- 2) Media sensor,
Check the media sensor for normal operation. If the operation is abnormal, replace the media sensor.
- 3) Replace the feed roller sensor unit
Check for normal operation. If the operation is abnormal, replace the feed roller sensor unit.
- 4) Replace the feed motor.
- 5) Replace the feed roller.

6) Replace the main controller PCB.

6.1.3.9 03010000-2E1F/03060000-2E14/03060A00-2E00/03061000-2E15/03063000-2E08/03860002-2E02/03860002-2E0A/03860002-2E0C Path mismatch error

<Cause>

The size of the media used to print the adjustment pattern was smaller than the specified one.
 The media size specified using the printer driver was different from the size of the actually loaded media.
 No roll media was loaded when data was received with roll media specified as a media type.
 The type of the loaded media was different from the media type specified using the printer driver.
 No cut media was loaded when data was received with cut media specified as a media type.
 Data requiring roll media was received when cut media were loaded.
 Data requiring cut media was received when roll media was loaded.

<Probable fault location>

Media type or main controller PCB

<Countermeasure>

1) Media check

Check the loaded media. If the media type is different from that required by the send data, no media is loaded, or the size of the loaded media is not the specified one, load correct media.

2) Replace the main controller PCB.

6.1.3.10 03862000-2E09 Insufficient roll media error

<Cause>

The machine detected that the remaining roll media was insufficient.

<Probable fault location>

Roll media or main controller PCB

<Countermeasure>

1) Replace the roll media.

2) Check the input value

Input the correct value of the remaining length of the roll media when setting it.

3) Replace the main controller PCB.

6.1.3.11 03890000-2920 Media take-up motor error

<Cause>

Media take-up motor cannot be driven.

<Probable fault location>

Media, media take-up paper detection sensor, media take-up motor, media take-up PCB, media take-up relay PCB, main controller PCB

<Countermeasure>

1) Visual check

If the winding media is abnormal, rewind the media correctly after the cause is removed.

Remove foreign substances between the light-emission unit and light-receiving unit of media take-up paper detection sensor if any.

2) Replace the media take-up paper detection sensor.

3) Replace the media take-up drive unit.

4) Replace the media take-up relay PCB.

5) Replace the main controller PCB.

6.1.3.12 03890000-2921 Media take-up paper detection sensor error

<Cause>

Media take-up paper detection sensor has detected foreign substances.

<Probable fault location>

Media take-up paper detection sensor, media take-up motor, media take-up PCB, media take-up relay PCB, main controller PCB

<Countermeasure>

1) Visual check

Remove foreign substances between the light-emission unit and light-receiving unit of media take-up paper detection sensor if any.

2) Replace the Media take-up paper detection sensor.

3) Cable continuity check

If continuity of the cable between the Replace the media take-up paper detection sensor and the media take-up drive unit is abnormal, replace the cable.

4) Replace the media take-up drive unit.

5) Replace the Media take-up relay PCB.

6) Replace the main controller PCB.

6.1.3.13 03060A00-2E1B Roll media end error

<Cause>

During printing or roll media feed, the media sensor detected the end of the roll media.

<Probable fault location>

Roll media, media sensor, or main controller PCB

<Countermeasure>

1) Roll media

If roll media is used up, load new roll media.

2) Media sensor

Check for normal operation. If the operation is abnormal, replace the media sensor.

3) Replace the main controller PCB.

6.1.3.14 03861001-2405/03861001-2406 Borderless printing error

<Cause>

The position where the media is loaded is not suitable for borderless printing.
The received data is not suitable for borderless printing.

<Probable fault location>

Operation method, media, multi sensor, main controller PCB

<Countermeasure>

- 1) Check the operation method and retry printing.
- 2) Media check
Check the loaded media. If it is abnormal, retry to load the media.
- 3) Multi sensor
Check for normal operation. If the operation is abnormal, replace the multi sensor.
- 4) Replace the main controller PCB

6.1.3.15 03810104-2500/03810101-2501/03810102-2502/03810103-2503/03810112-2504/03810113-2505/03810106-2506/ 03810105-2508/03810115-2509/03810107-250A/03810109-250B/03810108-250C No ink error

<Cause>

No ink status was detected in the ink tank.

<Probable fault location>

Ink tank, ink tank unit, or main controller PCB

<Countermeasure>

- 1) Replace the ink tank.
- 2) Replace the ink tank unit.
- 3) Replace the main controller PCB.

6.1.3.16 03830104-2520/03830101-2521/03830102-2522/03830103-2523/03830112-2524/03830113-2525/03830106-2526/ 03830105-2528/03830115-2529/03830107-252A/03830109-252B/03830108-252C Ink tank is not installed. (This error occurs when the ink tank is replaced.)

<Cause>

When the ink tank was replaced, the closed state of the ink cover was detected with the ink tank removed.

<Probable fault location>

Operation method, ink tank, ink tank cover switch, ink tank unit, or main controller PCB

<Countermeasure>

- 1) Operation check
Install the ink tank correctly.
- 2) Visual check
Remove foreign substances from the ink tank contacts and ink tank cover switch if any.
- 3) Replace the ink tank.
- 4) Ink tank cover switch
Check for normal operation. If the operation is abnormal, replace the ink tank cover switch.
- 5) Replace the ink tank unit.
- 6) Replace the main controller PCB.

6.1.3.17 03800204-2540/03830201-2541/03830202-2542/03830203-2543/03830212-2544/03830213-2545/03830206-2546/ 03830205-2548/03830215-2549/03830207-254A/03830209-254B/03830208-254C Invalid ink tank ID

<Cause>

The installed ink tank is wrong.

<Probable fault location>

Operation method, Ink tank, ink tank unit, or main controller PCB

<Countermeasure>

- 1) Operation check
Install the ink tank correctly.
- 2) Replace the ink tank.
- 3) Replace the ink tank unit.
- 4) Replace the main controller PCB.

6.1.3.18 03830304-2560/03830301-2561/03830302-2562/03830303-2563/03830312-2564/03830313-2565/03830306-2566/ 03830305-2568/03830305-2568/03830315-2569/03830307-256A/03830309-256B/03830308-256C Ink tank EEPROM error

<Cause>

An ink tank EEPROM checksum error was detected.

<Probable fault location>

Ink tank, ink tank unit, or main controller PCB

<Countermeasure>

- 1) Replace the ink tank.
- 2) Replace the ink tank unit.
- 3) Replace the main controller PCB.

6.1.3.19 03810204-2570/03810201-2571/03810202-2572/03810203-2573/03810212-2574/03810213-2575/03810206-2576/ 03810205-2578/03810215-2579/03810207-257A/03810209-257B/03810208-257C Ink low error (occurs when replacing the printhead)

<Cause>

The printhead was replaced when the levels of remaining ink was level one.

<Probable fault location>

Ink tank, ink tank unit, or main controller PCB

<Countermeasure>

- 1) Replace the ink tank.
- 2) Replace the ink tank unit.
- 3) Replace the main controller PCB.

**6.1.3.20 03810204-2580/03810201-2581/03810202-2582/03810203-2583/03810212-2584/03810213-2585/03810206-2586/
03810205-2588/03810215-2589/03810207-258A/03810209-258B/03810208-258C Ink low error (occures when cleaning B
is executed)**

<Cause>

Cleaning B was executed when the levels of remaining ink was level one.

<Probable fault location>

Ink tank, ink tank unit, or main controller PCB

<Countermeasure>

- 1) Replace the ink tank.
- 2) Replace the ink tank unit.
- 3) Replace the main controller PCB.

**6.1.3.21 03810204-2590/03810201-2591/03810202-2592/03810203-2593/03810212-2594/03810213-2595/03810206-2596/
03810205-2598/03810215-2599/03810207-259A/03810209-259B/03810208-259C Ink low error (occures when printing)**

<Cause>

Ink level low was detected when printing.

<Probable fault location>

Ink tank, ink tank unit, or main controller PCB

<Countermeasure>

- 1) Replace the ink tank.
- 2) Replace the ink tank unit.
- 3) Replace the main controller PCB.

**6.1.3.22 03800301-2801/03800201-2802/03800401-2803/03800201-2812/03800302-2809/03800202-280A/03800402-280B/
03800202-2813 Printhead error**

<Cause>

Improper installation of the printhead R was detected.
A checksum error was detected in the EEPROM of the printhead R.
Printhead R DI correction failed.
The version of printhead R was different.
Improper installation of the printhead L was detected.
A checksum error was detected in the EEPROM of the printhead L.
Printhead L DI correction failed.
The version of printhead L was different.

<Probable fault location>

Printhead, head relay PCB, carriage relay PCB, or main controller PCB

<Countermeasure>

- 1) Replace the printhead.
- 2) Cable continuity check
If continuity of the cable between the head relay PCB and the carriage relay PCB is abnormal, replace the cable.
- 3) Replace the Head relay PCB.
- 4) Cable continuity check
If continuity of the cable between the carriage relay PCB and the main controller PCB is abnormal, replace the cable.
- 5) Replace the carriage relay PCB.
- 6) Replace the main controller PCB.

6.1.3.23 03800101-2800/03800102-2808/03800201-2804/03800202-2807 Printhead installing error

<Cause>

Printhead R was not installed.
Printhead L was not installed.
Printhead R was installed to the left side.
Printhead L was installed to the right side.

<Probable fault location>

Operation method, printhead, head relay PCB, carriage relay PCB, or main controller PCB

<Countermeasure>

- 1) Operation check
Install the printhead properly.
- 2) Replace the printhead.
- 3) Cable continuity check
If continuity of the cable between the head relay PCB and the carriage relay PCB is abnormal, replace the cable.
- 4) Replace the Head relay PCB.
- 5) Cable continuity check
If continuity of the cable between the carriage relay PCB and the main controller PCB is abnormal, replace the cable.
- 6) Replace the carriage relay PCB.
- 7) Replace the main controller PCB.

6.1.3.24 03800501-280D/03800502-280E Defective printhead nozzle

<Cause>

Many non-discharging nozzles were detected on printhead R.
Many non-discharging nozzles were detected on printhead L.

<Probable fault location>

Printhead, head management sensor, or main controller PCB

<Countermeasure>

- 1) Clean the printhead.
- 2) Replace the printhead.
- 3) Replace the head management sensor.
- 4) Replace the main controller PCB.

6.1.3.25 03841201-2816/03841201-2817/03841101-2818/03841001-2819/03841001-281B Maintenance cartridge error

<Cause>

The maintenance cartridge is full.
The maintenance cartridge does not have the free space for various types of cleaning.
No maintenance cartridge is installed.
The EEPROM of the maintenance cartridge is abnormal.
A maintenance cartridge ID error occurred.

<Probable fault location>

Maintenance cartridge, maintenance cartridge relay PCB, or main controller PCB

<Countermeasure>

- 1) Replace the maintenance cartridge.
- 2) Replace the maintenance cartridge relay PCB.
- 3) Replace the main controller PCB.

6.1.3.26 03010000-2820/03010000-2821/03010000-2822/03010000-2823/03130031-2F32/03010000-2F33/ Adjustment error

<Cause>

Auto head alignment selected from the user menu could not be carried out because the alignment pattern read result was NG.
Auto LF adjustment selected from the user menu or in the service mode could not be carried out because the adjustment pattern read result was NG.
Decentering correction selected in the service mode cannot be carried out because the correction pattern read result was NG.
Auto LF adjustment selected from the user menu or in the service mode could not be carried out because the head check pattern read result was NG.
Optical axis adjustment selected in the service mode cannot be carried out because the adjustment pattern read result was NG.



When adjustment has been carried after selecting [SERVICE MODE]>[ADJUST]>[PRINT PATTERN]>[OPTICAL AXIS] or [SERVICE MODE]>[ADJUST]>[PRINT PATTERN]>[LF TUNING] in the service mode, check that photo glossy paper is used.

<Probable fault location>

Operation method, printhead, multi sensor, head relay PCB, carriage relay PCB, or main controller PCB

<Countermeasure>

- 1) Check whether the media type selected on the operation panel is the same as the type of the media used to print the adjustment pattern. If they are different, retry adjustment using the media of the type selected on the operation panel.
- 2) If ink bleeds greatly, change the media.
- 3) Carry out head cleaning, and retry adjustment. If the adjustment result is poor, replace the printhead.
- 4) Cable continuity check
If continuity of the cable between the multi sensor and the head relay PCB is abnormal, replace the cable.
- 5) Cable continuity check
If continuity of the cable between the head relay PCB and the carriage relay PCB is abnormal, replace the cable.
- 6) Cable continuity check
If continuity of the cable between the carriage relay PCB and the main controller PCB is abnormal, replace the cable.
- 7) Replace the multi sensor, and then retry adjustment.
- 8) Replace the head relay PCB.
- 9) Replace the carriage relay PCB.
- 10) Replace the main controller PCB.

6.1.3.27 03130031-260E Gap detection error

<Cause>

A detection error occurred due to damaged hardware, uncorrected gap, or damaged correction data.

<Probable fault location>

Multi sensor, head relay PCB, carriage relay PCB or main controller PCB

<Countermeasure>

- 1) Cable continuity check
If continuity of the cable between the multi sensor and the head relay PCB is abnormal, replace the cable.
- 2) Replace the multi sensor.
- 3) Cable continuity check
If continuity of the cable between the head relay PCB and the carriage relay PCB is abnormal, replace the cable.
- 4) Replace the head relay PCB.
- 5) Cable continuity check
If continuity of the cable between the carriage relay PCB and the main controller PCB is abnormal, replace the cable.
- 6) Replace the carriage relay PCB.
- 7) Replace the main controller PCB.

6.1.3.28 03130031-260F Gap adjustment error

<Cause>

Gap reference surface error (This error occurs only in the service mode.)

<Probable fault location>

Multi sensor reference plate, multi sensor, head relay PCB, carriage relay PCB or main controller PCB

<Countermeasure>

- 1) Replace the multi sensor reference plate.
- 2) Cable continuity check
If continuity of the cable between the multi sensor and the head relay PCB is abnormal, replace the cable.
- 3) Replace the multi sensor.
- 4) Cable continuity check
If continuity of the cable between the head relay PCB and the carriage relay PCB is abnormal, replace the cable.
- 5) Replace the head relay PCB.
- 6) Cable continuity check
If continuity of the cable between the carriage relay PCB and the main controller PCB is abnormal, replace the cable.
- 7) Replace the carriage relay PCB.
- 8) Replace the main controller PCB.

6.1.3.29 03130031-2618 VH voltage abnormality error**<Cause>**

The voltage of the print head is abnormal.

<Probable fault location>

Printhead, head relay PCB, carriage relay PCB, main controller PCB

<Countermeasure>

- 1) Replace the printhead.
- 2) Cable continuity check
If continuity of the cable between the head relay PCB and the carriage relay PCB is abnormal, replace the cable.
- 3) Replace the head relay PCB.
- 4) Cable continuity check
If continuity of the cable between the carriage relay PCB and the main controller PCB is abnormal, replace the cable.
- 5) Replace the carriage relay PCB.
- 6) Replace the main controller PCB.

6.1.3.30 03800500-2F2F/03800500-2F30 Head management sensor error**<Cause>**

The head management sensor detected an ink discharge error.
A sensor sensitivity error was detected during head management sensor position adjustment.

<Probable fault location>

Printhead, head management sensor, or main controller PCB

<Countermeasure>

- 1) Replace the print head.
- 2) Visual check
Remove foreign substances from the head management sensor if any.
- 3) Replace the head management sensor.
- 4) Replace the main controller PCB.

6.1.3.31 03130031-2F16 Mist fan error**<Cause>**

Mist fan rotation could not be detected during mist fan rotation.

<Probable fault location>

Mist fan, main controller PCB

<Countermeasure>

- 1) Replace the mist fan.
- 2) Replace the main controller PCB.

6.1.3.32 03130031-2F17 Suction fan error**<Cause>**

When the suction fan was driven, the lock signal was detected for more than the specified time.

<Probable fault location>

Suction fan or main controller PCB

<Countermeasure>

- 1) Suction fan
- 2) Replace the main controller PCB.

6.1.3.33 03030000-2E21 IEEE1394 Error**<Cause>**

The IEEE1394 interface is faulty.

<Probable fault location>

IEEE1394 interface board or main controller PCB

<Countermeasure>

- 1) Turn off the printer, and then turn it on again.
- 2) IEEE1394 interface board
Remove the IEEE1394 interface board, install it again, and then turn on the printer. If the trouble persists, replace the IEEE1394 interface board.
- 3) Replace the main controller PCB.

6.1.3.34 03130031-2F25 Carriage home position error

<Cause>

The carriage home position could not be detected within the specified time.

<Probable fault location>

Sensor flag, carriage HP sensor, linear scale, linear encoder, carriage relay PCB, or main controller PCB

<Countermeasure>

- 1) Visual check
Remove foreign substances from the sensor flag, carriage HP sensor, linear scale, and linear encoder if any.
- 2) Replace the carriage HP sensor.
- 3) Replace the linear scale.
- 4) Replace the linear encoder.
- 5) Replace the carriage relay PCB.
- 6) Replace the main controller PCB.

6.1.3.35 03130031-2F26/03130031-2F27 Carriage motor error

<Cause>

The carriage did not operate because the carriage motor was overloaded due to a physical cause such as a jam.
The carriage motor did not reach the specified speed within the specified time.

<Probable fault location>

Carriage pathway, carriage rail, carriage belt, linear scale, linear encoder, carriage motor, carriage relay PCB, or main controller PCB

<Countermeasure>

- 1) Carriage pathway check
Remove foreign substances (jammed paper) from the carriage pathway if any.
- 2) Carriage rail
Visually check whether the carriage rail is dirty. If the carriage rail is dirty, clean it.
- 3) Carriage belt
Visually check whether the carriage belt is loose. If the carriage belt is loose, remove it and then reinstall it.
- 4) Replace the linear scale.
- 5) Replace the linear encoder.
- 6) Replace the carriage motor.
- 7) Replace the carriage relay PCB.
- 8) Replace the main controller PCB.

6.1.3.36 03130031-2F1F/03130031-2F20 Defective sensor in purge unit

<Cause>

The each sensors in the purge unit could not detect the home position of the purge motor within the specified time.

<Probable fault location>

Purge unit or main controller PCB

<Countermeasure>

- 1) Visual check
Remove foreign substance from purge unit if any.
- 2) Replace the purge unit.
- 3) Replace the main controller PCB.

6.1.3.37 03130031-2F22/03130031-2F23/03130031-2F2D Purge motor driving error

<Cause>

The purge motor did not reach the specified speed within the specified time.

<Probable fault location>

Purge unit or main controller PCB

<Countermeasure>

- 1) Visual check
Remove foreign substance from purge unit if any.
- 2) Replace the purge unit.
- 3) Replace the main controller PCB.

6.1.3.38 03130031-2F2A Feed roller home position error

<Cause>

During power-on, the feed roller HP sensor could not detect that the reference of Scale that exists on encoder film area color change from transparent to black.

<Probable fault location>

Feed roller encoder film, feed roller encoder, feed roller HP sensor, feed motor, or main controller PCB

<Countermeasure>

- 1) Visual check
Remove foreign substances from the feed roller encoder film if any.
- 2) Feed roller sensor unit
Check for normal operation. If the operation is abnormal, replace the feed roller sensor unit.
- 3) Replace the feed roller encoder film (pulley unit).
- 4) Replace the feed motor.
- 5) Replace the main controller PCB.

6.1.3.39 03130031-2F3A valve open/close error

<Cause>

When the ink supply valve opened or closed, valve open/closed detection sensor could not detect the valve cam rotation.

<Probable fault location>

Valve open/closed detection sensor, valve motor, or main controller PCB

<Countermeasure>

1) Visual check

Remove foreign substances from the motor, gear, and sensor of the valve open/close mechanism if any.

2) Replace the ink supply drive unit.

3) Replace the main controller PCB.

6.1.3.40 03130031-2F2E Roll media feeding error**<Cause>**

The media sensor could not detect the media within the specified time.

<Probable fault location>

Media, media sensor, roll media feeding unit, or main controller PCB

<Countermeasure>

1) Visual check

If the media is bent, set the media once again.

2) Replace the media sensor.

3) Replace the roll media feeding unit.

4) Replace the main controller PCB.

6.1.3.41 03130031-2F28 Lift motor time out error**<Cause>**

The lift cam sensor could not detect the home position of the lift motor within the specified time.

<Probable fault location>

Lift cam, lift cam sensor, lift drive unit, or main controller PCB

<Countermeasure>

1) Visual check

Remove foreign substances from the lift cam or the lift drive unit if any.

2) Replace the lift cam.

3) Replace the lift cam sensor.

4) Replace the lift drive unit.

5) Replace the main controller PCB.

6.1.3.42 03130031-2F13 A/D Converter external trigger output stopped**<Cause>**

Defective main controller PCB

<Probable fault location>

Main controller PCB

<Countermeasure>

1) Turn off the printer, and then turn it off again.

2) Replace the main controller PCB.

6.1.3.43 03130031-2F14 ASIC Register cannot be written.**<Cause>**

A main controller PCB firmware error occurred.

<Probable fault location>

Main controller PCB

<Countermeasure>

1) Turn off the printer, and then turn it on again.

2) Replace the main controller PCB.

6.1.3.44 03900001-4042/03900001-4049 Firmware error**<Cause>**

Firmware cannot be recognized.

The firmware is for another model.

<Probable fault location>

Firmware or main controller PCB

<Countermeasure>

1) Firmware

Check the version of the transferred firmware and the compatible models.

2) Replace the main controller PCB.

6.1.3.45 E194-4034 Sensor calibration error**<Cause>**

When executing [SERVICE MODE] > [ADJUST] > [SENSOR CALIB.], multi sensor calibration could not be done.

<Probable fault location>

Test chart, multi sensor, main controller PCB

<Countermeasure>

1) Test chart

Check the test chart. if there is a problem, exchange it.

2) Multi sensor

Check for normal operation. If the operation is abnormal, replace it.

3) Replace the main controller PCB

6.1.4 Troubleshooting When Service Call Errors Occur

6.1.4.1 E141-4046 Recovery system's count error

<Cause>

The machine detected that the rotation count of the purge unit reached the specified value.

<Probable fault location>

Purge unit or main controller PCB

<Countermeasure>

- 1) Replace the purge unit.
After replacing the purge unit, select [SERVICE MODE]>[INITIALIZE]>[PARTS COUNTER] to reset the counter.
- 2) Replace the main controller PCB.

6.1.4.2 E144-4047 Supply system's count error

<Cause>

The machine detected that the carriage scan count reached the specified value.

<Probable fault location>

Ink tube unit, or main controller PCB

<Countermeasure>

- 1) Replace the ink tube unit.
After replacing the ink tube unit, select [SERVICE MODE] > [INITIALIZE] > [PARTS COUNTER] to reset the counter.
- 2) Replace the main controller PCB.

6.1.4.3 E146-4001 Waste ink count full

<Cause>

The machine detected that the waste ink box or the fan unit became full of ink.

<Probable fault location>

Waste ink box, fan unit, or main controller PCB

<Countermeasure>

- 1) Replace the waste ink box or fan unit.
After replacing the waste ink box or fan unit, select [SERVICE MODE] > [INITIALIZE] > [PARTS COUNTER] to reset the counter.
- 2) Replace the main controller PCB.

6.1.4.4 E161-403E/E161-403F Abnormally high head temperature

<Cause>

The printhead temperature became abnormally high.

<Probable fault location>

Printhead, head relay PCB, carriage relay PCB, or main controller PCB

<Countermeasure>

- 1) Start up the printer in the service mode, and then replace the printhead.
- 2) Replace the head relay PCB.
- 3) Replace the carriage relay PCB.
- 4) Replace the main controller PCB.

6.1.4.5 E194-404A Non-discharge detection count error

<Cause>

The machine detected that the non-discharge count reached the specified value.

<Probable fault location>

Head management sensor or main controller PCB

<Countermeasure>

- 1) Replace the head management sensor.
After replacing the head management sensor, select [SERVICE MODE] > [INITIALIZE] > [PARTS COUNTER] to reset the counter.
- 2) Replace the main controller PCB.

6.1.4.6 E196-4040/E196-4041/E196-4042/E196-4043/E196-4044/E196-4045 Main controller PCB error

<Cause>

The main controller PCB is defective.

<Probable fault location>

Firmware or main controller PCB

<Countermeasure>

- 1) Upgrade the firmware.
- 2) Replace the main controller PCB.

6.1.4.7 E198-401C/E198-401D/E198-401E RTC error

<Cause>

The RTC of the main controller is not found.
The battery capacity is low.

<Probable fault location>

Lithium battery or main controller

<Countermeasure>

- 1) Start up the printer in the service mode, and then turn off the power.
- 2) Replace the lithium battery.
- 3) Replace the main controller

6.2 Location of Connectors and Pin Arrangement

6.2.1 Main controller PCB

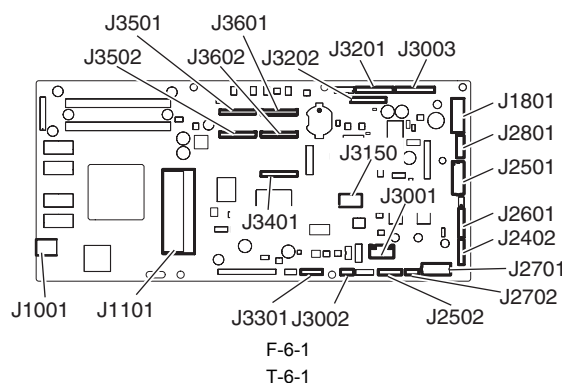

J1001			
Pin Number	Signal name	IN/OUT	Function
1	VBUS	IN	USB VBUS(+5V)
2	D-	IN/OUT	USB data(-)
3	D+	IN/OUT	USB data(+)
4	AGND	-	USB GND
5	FGND	-	GND (Connector shell)
6	FGND	-	GND (Connector shell)

T-6-2

J1101			
Pin Number	Signal name	IN/OUT	Function
1	GND	-	GND
2	GND	-	GND
3	GND	-	GND
4	+3.3V	OUT	power supply(+3.3V)
5	+3.3V	OUT	power supply(+3.3V)
6	+3.3V	OUT	power supply(+3.3V)
7	+3.3V	OUT	power supply(+3.3V)
8	+3.3V	OUT	power supply(+3.3V)
9	+3.3V	OUT	power supply(+3.3V)
10	N.C.	-	N.C.
11	GND	-	GND
12	/PME	IN	Power management enable signal
13	/INTA	IN	Interrupt signal
14	GND	-	GND
15	/RST	OUT	PCI Reset signal
16	CLK	OUT	PCI Clock signal
17	/GNT	OUT	Ground signal
18	GND	-	GND
19	/REQ	IN	Request signal
20	AD31	IN/OUT	Address and data signal
21	AD30	IN/OUT	Address and data signal
22	AD29	IN/OUT	Address and data signal
23	AD28	IN/OUT	Address and data signal
24	GND	-	GND
25	AD27	IN/OUT	Address and data signal
26	AD26	IN/OUT	Address and data signal
27	AD25	IN/OUT	Address and data signal
28	AD24	IN/OUT	Address and data signal
29	/CBE3	IN/OUT	Bus command and byte enable signal

J1101			
Pin Number	Signal name	IN/OUT	Function
30	IDSEL	OUT	Inisharaization device select signal
31	GND	-	GND
32	GND	-	GND
33	AD23	IN/OUT	Address and data signal
34	AD22	IN/OUT	Address and data signal
35	AD21	IN/OUT	Address and data signal
36	AD20	IN/OUT	Address and data signal
37	GND	-	GND
38	AD19	IN/OUT	Address and data signal
39	AD18	IN/OUT	Address and data signal
40	AD17	IN/OUT	Address and data signal
41	AD16	IN/OUT	Address and data signal
42	/CBE2	OUT	Bus command and byte enable signal
43	GND	-	GND
44	/FRAME	IN/OUT	Cycle frame signal
45	/IRDY	IN/OUT	Initiator ready signal
46	/TRDY	IN/OUT	Target ready signal
47	/DEVSEL	IN/OUT	Device select signal
48	GND	-	GND
49	/STOP	IN/OUT	Stop signal
50	/LOCK	IN/OUT	Lock signal
51	/PERP	IN/OUT	Parity error signal
52	/SERR	IN/OUT	System error signal
53	PAR	IN/OUT	Parity signal
54	/CBE1	IN/OUT	Bus command and byte enable signal
55	GND	-	GND
56	GND	-	GND
57	AD15	IN/OUT	Address and data signal
58	AD14	IN/OUT	Address and data signal
59	AD13	IN/OUT	Address and data signal
60	AD12	IN/OUT	Address and data signal
61	GND	-	GND
62	AD11	IN/OUT	Address and data signal
63	AD10	IN/OUT	Address and data signal
64	AD9	IN/OUT	Address and data signal
65	AD8	IN/OUT	Address and data signal
66	/CBE0	IN/OUT	Bus command and byte enable signal
67	GND	-	GND
68	AD7	IN/OUT	Address and data signal
69	AD6	IN/OUT	Address and data signal
70	AD5	IN/OUT	Address and data signal
71	AD4	IN/OUT	Address and data signal
72	GND	-	GND
73	AD3	IN/OUT	Address and data signal
74	AD2	IN/OUT	Address and data signal
75	AD1	IN/OUT	Address and data signal
76	AD0	IN/OUT	Address and data signal
77	GND	-	GND
78	HDD_LED	-	N.C.
79	+5V	OUT	power supply(+5V)
80	+5V	OUT	power supply(+5V)
81	+5V	OUT	power supply(+5V)
82	+3.3V	OUT	power supply(+3.3V)
83	+3.3V	OUT	power supply(+3.3V)
84	+3.3V	OUT	power supply(+3.3V)
85	GND	-	GND
86	GND	-	GND
87	GND	-	GND
88	GND	-	GND

T-6-3

J1801			
Pin Number	Signal name	IN/OUT	Function
1	RGV20(+5V)	IN	Power supply(+5V)
2	RGV20(+5V)	IN	Power supply(+5V)

J1801			
Pin Number	Signal name	IN/OUT	Function
3	RGV20(+5V)	IN	Power supply(+5V)
4	GND	-	GND
5	GND	-	GND
6	GND	-	GND
7	VM	IN	Power supply(+32V)
8	VM	IN	Power supply(+32V)
9	VMGND	-	GND
10	VMGND	-	GND
11	VM_ENB	OUT	VM enable signal
12	AFCONT	OUT	Normal/Power saving switch signal

T-6-4

J2402			
Pin Number	Signal name	IN/OUT	Function
1	INKBENM2_AM	OUT	Left valve motor drive signal AM
2	INKBENM2_AP	OUT	Left valve motor drive signal AP
3	SNS3V	OUT	Power supply(+3.3V)
4	GND	-	GND
5	/INKBEN_OPEN_L	IN	Left valve open/close detection sensor output signal
6	/TANK_COVER_L	IN	Left ink tank cover switch output signal
7	GND	-	GND
8	SNS3V	OUT	Power supply(+3.3V)
9	GND	-	GND
10	/INKBEN_CAM_L	IN	Left ink tank agitation cam sensor output signal
11	N.C	-	N.C

T-6-5

J2501			
Pin Number	Signal name	IN/OUT	Function
A1	N.C	-	N.C
A2	N.C	-	N.C
A3	N.C(LIFT_CAM)	-	N.C
A4	SNS3V	OUT	Power supply(+3.3V)
A5	GND	-	GND
A6	/CR_HP	IN	Lift cam sensor output signal
A7	OUT_LIFTM_VM	OUT	Power supply
A8	OUT_LIFTM0_A	OUT	Lift motor drive signal A
A9	OUT_LIFTM2_AX_N0	OUT	Lift motor drive signal AX
A10	OUT_LIFTM1_B	OUT	Lift motor drive signal B
A11	OUT_LIFTM3_BX_N1	OUT	Lift motor drive signal BX
A12	/ATUKAIJYO	IN	Pressure release switch output signal
A13	GND	-	GND
B1	PUMPM1_AM	OUT	Purge motor drive signal AM
B2	PUMPM1_AP	OUT	Purge motor drive signal AP
B3	GND	-	GND
B4	PUMPR_ENCA	IN	Pump encoder output signal A
B5	SNS5V	OUT	Power supply(+5V)
B6	PUMPR_ENCB	IN	Pump encoder output signal B
B7	SNS3V	OUT	Power supply(+3.3V)
B8	GND	-	GND
B9	/CONTROL_CAM_R	IN	Pump cam sensor output signal
B10	GND	-	GND
B11	/MEDIA_R	IN	Media sensor output signal
B12	SNS5V	OUT	Power supply(+5V)
B13	N.C	-	N.C

T-6-6

J2502			
Pin Number	Signal name	IN/OUT	Function
1	INKBENM1_AM	OUT	Right valve motor drive signal AM
2	INKBENM1_AP	OUT	Right valve motor drive signal AP
3	SNS3V	OUT	Power supply(+3V)
4	GND	-	GND
5	/INKBEN_OPEN_R	IN	Right valve open/close detection sensor output signal
6	/TANK_COVER_R	IN	Right ink tank cover switch output signal
7	GND	-	GND
8	SNS3V	OUT	Power supply(+3V)

J2502			
Pin Number	Signal name	IN/OUT	Function
9	GND	-	GND
10	/INKBEN_CAM_R	IN	Right agtation cam sensor output signal

T-6-7

J2601			
Pin Number	Signal name	IN/OUT	Function
1	POWER_ON	IN	Power switch signal
2	GND	-	GND
3	RGV20(+5V)	OUT	Power supply(+5V)
4	BUZZER	OUT	Buzzer control signal
5	PDO	OUT	Panel IC control signal
6	+3.3V	OUT	Power supply(+3.3V)
7	PDI	OUT	Panel IC data signal
8	GND	OUT	GND
9	/PRESET	OUT	Panel reset signal
10	GND	-	GND
11	PCK	OUT	Panel IC clock signal
12	PANEL_5V	OUT	Power supply(+5V)
13	/PCS	OUT	Panel IC chip select signal

T-6-8

J2701			
Pin Number	Signal name	IN/OUT	Function
A1	GND	-	GND
A2	LF_ENCB	IN	Feed roller encoder output signal B
A3	+5V	OUT	Power supply(+5V)
A4	LF_ENCA	IN	Feed roller encoder output signal A
A5	SNS3V	OUT	Power supply(+3.3V)
A6	GND	-	GND
A7	/LF_HP	IN	Feed roller HP sensor output signal
A8	N.C.	-	N.C.
A9	N.C.	-	N.C.
A10	VM_26V	OUT	Power supply(+26V)
A11	/SPOOL_CL	OUT	Media take up clutch drive signal
B1	VM_26V	OUT	Power supply(+26V)
B2	KYUINFAN_ALARM_IN	IN	Suction fan alarm signal
B3	KYUINFAN_PWM_ON	OUT	Suction fan duty control signal
B4	GND	-	GND
B5	VM_26V	OUT	Power supply(+26V)
B6	MISTFAN_R_ALARM	IN	Mist fan(R) alarm signal
B7	GND	-	GND
B8	VM_26V	OUT	Power supply(+26V)
B9	MISTFAN_L_ALARM	IN	Mist fan(L) alarm signal
B10	GND	-	GND
B11	N.C.	-	N.C.

T-6-9

J2702			
Pin Number	Signal name	IN/OUT	Function
1	VM 26V	OUT	Power supply(+26V)
2	/DCOVER_SOL_L	OUT	Upper cover lock solenoid(L) drive signal
3	VM 26V	OUT	Power supply(+26V)
4	/DCOVER_SOL_R	OUT	Upper cover lock solenoid(R) drive signal
5	N.C.	-	N.C.
6	N.C.	-	N.C.

T-6-10

J2801			
Pin Number	Signal name	IN/OUT	Function
1	LFSP_A	OUT	Feed motor drive signal A
2	LFSP_VM	OUT	Power supply(+32V)
3	LFSP_AB	OUT	Feed motor drive signal AB
4	LFSP_BB	OUT	Feed motor drive signal BB
5	LFSP_VM	OUT	Power supply(+32V)
6	LFSP_B	OUT	Feed motor drive signal B

T-6-11

J3001			
Pin Number	Signal name	IN/OUT	Function
1	RGV16(VM)	OUT	Power supply(+32v)
2	-	-	-
3	-	-	-
4	RGV18(VM_CR)	IN	Upper cover lock switch output signal

T-6-12

J3002			
Pin Number	Signal name	IN/OUT	Function
1	TH	IN	Thermister output signal
2	GND	-	GND
3	Vout	IN	Humidity sensor output signal
4	+5V	OUT	Power supply(+5v)

T-6-13

J3003			
Pin Number	Signal name	IN/OUT	Function
1	/MAKITORI_UNIT	IN	Media take up paper detection sensor
2	/MAKITORI_LOCK_SENS	IN	Media take up on/off sensor output signal
3	/MAKITORI_VCC_ON	OUT	Power supply ON signal
4	MAKITORI_VM_ON	OUT	Power supply(+26V)
5	/MAKITORI_ENB	OUT	Media take up drive enable signal
6	PHOTO_SENS_OUT	IN	Media take up paper detection sensor output signal
7	VM_26V	OUT	Power supply(+26V)
8	VM_26V	OUT	Power supply(+26V)
9	VMGND	-	GND
10	VMGND	-	GND
11	+5V	OUT	Power supply(+5V)
12	N.C.	-	N.C
13	N.C.	-	N.C
14	N.C.	-	N.C

T-6-14

J3150			
Pin Number	Signal name	IN/OUT	Function
1	IN 3-	IN	Hole sensor input signal 3-
2	IN 3+	IN	Hole sensor input signal 3+
3	IN 1+	IN	Hole sensor input signal 1+
4	IN 2-	IN	Hole sensor input signal 2-
5	IN 1-	IN	Hole sensor input signal 1-
6	IN 2+	IN	Hole sensor input signal 2+
7	VM_GND	-	GND
8	+5V	OUT	Power supply (+5V)
9	OUT B	OUT	Motor output signal B
10	OUT B	OUT	Motor output signal B
11	OUT A	OUT	Motor output signal A
12	OUT A	OUT	Motor output signal A
13	OUT C	OUT	Motor output signal C
14	OUT C	OUT	Motor output signal C

T-6-15

J3201			
Pin Number	Signal name	IN/OUT	Function
1	TANK_CLK	OUT	Ink tank clock signal
2	GND	-	GND
3	OUT_TANK_DAT2	IN/OUT	Ink tank data signal 2
4	TANK_+3.3V	OUT	Power supply(+3.3V)
5	OUT_TANK_DAT1	IN/OUT	Ink tank data signal 1
6	OUT_TANK_DAT0	IN/OUT	Ink tank data signal 0
7	GND	-	GND
8	OUT_INK_DETECT0	IN	Ink detection sensor output signal 0
9	OUT_INK_DETECT1	IN	Ink detection sensor output signal 1
10	OUT_INK_DETECT2	IN	Ink detection sensor output signal 2
11	OUT_TANK_DAT5	IN/OUT	Ink tank data signal 5
12	OUT_TANK_DAT4	IN/OUT	Ink tank data signal 4
13	OUT_TANK_DAT3	IN/OUT	Ink tank data signal 3
14	OUT_INK_DETECT3	IN	Ink detection sensor output signal 3
15	OUT_INK_DETECT4	IN	Ink detection sensor output signal 4

J3201			
Pin Number	Signal name	IN/OUT	Function
16	OUT_INK_DETECT5	IN	Ink detection sensor output signal 5
17	N.C.	-	N.C.

T-6-16

J3202			
Pin Number	Signal name	IN/OUT	Function
1	TANK_CLK	OUT	Ink tank clock signal
2	GND	-	GND
3	OUT_TANK_DAT8	IN/OUT	Ink tank data signal 8
4	TANK_+3.3V	OUT	Power supply(+3.3V)
5	OUT_TANK_DAT7	IN/OUT	Ink tank data signal 7
6	OUT_TANK_DAT6	IN/OUT	Ink tank data signal 6
7	GND	-	GND
8	OUT_INK_DETECT6	IN	Ink detection sensor output signal 6
9	OUT_INK_DETECT7	IN	Ink detection sensor output signal 7
10	OUT_INK_DETECT8	IN	Ink detection sensor output signal 8
11	OUT_TANK_DAT11	IN/OUT	Ink tank data signal 11
12	OUT_TANK_DAT10	IN/OUT	Ink tank data signal 10
13	OUT_TANK_DAT9	IN/OUT	Ink tank data signal 9
14	OUT_INK_DETECT9	IN	Ink detection sensor output signal 9
15	OUT_INK_DETECT10	IN	Ink detection sensor output signal 10
16	OUT_INK_DETECT11	IN	Ink detection sensor output signal 11

T-6-17

J3301			
Pin Number	Signal name	IN/OUT	Function
1	MENT_SDA	IN/OUT	Maintenance cartridge ROM control signal (data)
2	MENT_SCL	IN/OUT	Maintenance cartridge ROM control signal (clock)
3	GND	-	GND
4	+3.3V	OUT	Power supply (+3.3V)
5	GND	-	GND
6	/FUTO_CLMP	OUT	Head management sensor clamp signal
7	/FUTO_ON	OUT	Head management sensor ON signal
8	SNS5V	OUT	Power supply(+5V)
9	/FUTO_CMP	IN	Head management sensor ink detection signal

T-6-18

J3401			
Pin Number	Signal name	IN/OUT	Function
1	VMGND	-	GND
2	VMGND	-	GND
3	VMGND	-	GND
4	VMGND	-	GND
5	VH_MONI1	IN	VH controll signal 1
6	VH_ENB	OUT	VHPower supply ON/OFF signal
7	VH_MONI2	IN	VH controll signal 2
8	GND	-	GND
9	+3.3V	OUT	Power supply(+3.3V)
10	+3.3V	OUT	Power supply(+3.3V)
11	GND	-	GND
12	SNS5V	OUT	Power supply(+5V)
13	SNS5V	OUT	Power supply(+5V)
14	VM	OUT	Power supply(+32V)
15	VM	OUT	Power supply(+32V)
16	VM	OUT	Power supply(+32V)
17	VM	OUT	Power supply(+32V)
18	VM	OUT	Power supply(+32V)
19	VM	OUT	Power supply(+32V)
20	VM	OUT	Power supply(+32V)
21	VM	OUT	Power supply(+32V)
22	VMGND	-	GND
23	VMGND	-	GND
24	VMGND	-	GND
25	VMGND	-	GND

T-6-19

J3501			
Pin Number	Signal name	IN/OUT	Function
1	GND	-	GND
2	GND	-	GND
3	VH_MONI3	IN	VH controll signal 3
4	GND	-	GND
5	GND	-	GND
6	H0-D-DATA-7-OD_B	OUT	Odd head(R) data signal 7(D)
7	GND	-	GND
8	H0-E-HE-8_B	OUT	Head(R) heat enable signal 8(E)
9	GND	-	GND
10	H0-E-DATA-8-OD_B	OUT	Odd head(R) data signal 8(E)
11	GND	-	GND
12	H0-F-DATA-10-OD_B	OUT	Odd head(R) data signal 10(F)
13	GND	-	GND
14	H0-E-DATA-9-OD_B	OUT	Odd head(R) data signal 9(E)
15	GND	-	GND
16	H0-F-HE-10_B	OUT	Head(R) heat enable signal 10(F)
17	GND	-	GND
18	H0-F-DATA-11-OD_B	OUT	Odd head(R) data signal 11(F)
19	GND	-	GND
20	H0-F-HE-11_B	OUT	Head(R) heat enable signal 11(F)
21	GND	-	GND
22	H0-F-DATA-11-EV_B	OUT	Even head(R) data signal 11(F)
23	GND	-	GND
24	H0-F-DATA-10-EV_B	OUT	Even head(R) data signal 10(F)
25	GND	-	GND
26	H0-E-HE-9_B	OUT	Head(R) heat enable signal 9(E)
27	GND	-	GND
28	H0-E-DATA-9-EV_B	OUT	Even head(R) data signal 9(E)
29	GND	-	GND
30	H-DASH LICC2_B		Head analogue switch A/D trigger signal
31	GND	-	GND
32	H0-A-DATA-0-OD_B	OUT	Odd head(R) data signal 0(A)
33	GND	-	GND
34	H0-A-DATA-1-OD_B	OUT	Odd head(R) data signal 1(A)
35	GND	-	GND
36	H0-B-HE-2_B	OUT	Head(R) heat enable signal 2(B)
37	GND	-	GND
38	H0-B-DATA-2-OD_B	OUT	Odd head(R) data signal 2(B)
39	GND	-	GND
40	H0-B-DATA-3-OD_B	OUT	Odd head(R) data signal 3(B)
41	GND	-	GND
42	H0-C-HE-4_B	OUT	Head(R) heat enable signal 4(C)
43	GND	-	GND
44	H0-C-DATA-4-OD_B	OUT	Odd head(R) data signal 4(C)
45	GND	-	GND
46	GND	-	GND
47	GND	-	GND
48	VH_MONI4	IN	VH controll signal 4
49	GND	-	GND
50	GND	-	GND

T-6-20

J3502			
Pin Number	Signal name	IN/OUT	Function
1	GND	-	GND
2	H0-E-DATA-8-EV_B	OUT	Even head(R) data signal 8(E)
3	GND	-	GND
4	H0-D-HE-7_B	OUT	Head(R) heat enable signal 7(D)
5	GND	-	GND
6	H0-D-DATA-7-EV_B	OUT	Even head(R) data signal 7(D)
7	GND	-	GND
8	H0-D-DATA-6-EV_B	OUT	Even head(R) data signal 6(D)
9	GND	-	GND
10	H0-D-DATA-6-OD_B	OUT	Odd head(R) data signal 6(D)
11	GND	-	GND

J3502			
Pin Number	Signal name	IN/OUT	Function
12	H0-D-HE-6_B	OUT	Head(R) heat enable signal 6(D)
13	GND	-	GND
14	H0-C-HE-5_B	OUT	Head(R) heat enable signal 5(C)
15	GND	-	GND
16	H0-C-DATA-5-OD_B	OUT	Odd head(R) data signal 5(C)
17	GND	-	GND
18	H0-DSOUT2	OUT	Head(R) temperature output signal 2
19	GND	-	GND
20	H0-DSOUT1	OUT	Head(R) temperature output signal 1
21	GND	-	GND
22	H0-DLD_LICC2	OUT	Head(R) analogue switch latch signal
23	H0-DATA_LICC2	OUT	Head(R) analogue switch data signal
24	H0-DASLK_LICC2	OUT	Head(R) analogue switch clock signal
25	GND	-	GND
26	GND	-	GND
27	GND	-	GND
28	H0_CLK_B	OUT	Head(R) clock signal
29	GND	-	GND
30	H0_LT_B	OUT	Head(R) latch signal
31	GND	-	GND
32	H0-C-DATA-5-EV_B	OUT	Even head(R) data signal 5(C)
33	GND	-	GND
34	LIFT_CAM_IN	IN	Lift cam sensor output signal
35	GND	-	GND
36	H0-B-HE-3_B	OUT	Head(R) heat enable signal 3(B)
37	GND	-	GND
38	H0-C-DATA-4-EV_B	OUT	Even head(R) data signal 4(C)
39	GND	-	GND
40	H0-B-DATA-3-EV_B	OUT	Even head(R) data signal 3(B)
41	GND	-	GND
42	H0-B-DATA-2-EV_B	OUT	Even head(R) data signal 2(B)
43	GND	-	GND
44	H0-A-DATA-1-EV_B	OUT	Even head(R) data signal 1(A)
45	GND	-	GND
46	H0-A-HE-1_B	OUT	Head(R) heat enable signal 1(A)
47	GND	-	GND
48	H0-A-DATA-0-EV_B	OUT	Even head(R) data signal 0(A)
49	GND	-	GND
50	H0-A-HE-0_B	OUT	Head(R) heat enable signal 0(A)

T-6-21

J3601			
Pin Number	Signal name	IN/OUT	Function
1	ENCODER_A	IN	Carriage encoder output signal A
2	ENCODER_B	IN	Carriage encoder output signal B
3	GND	-	GND
4	CR_COVER	IN	Carriage cover sensor output signal
5	OUT_ENB	OUT	Head data enable signal
6	H-DASH_LICC2_B	OUT	Head analogue switch A/D trigger signal
7	GND	-	GND
8	H1-D-DATA-7-OD_B	OUT	Odd head(R) data signal 7(D)
9	GND	-	GND
10	H1-E-HE-8_B	OUT	Head(R) heat enable signal 8(E)
11	GND	-	GND
12	H1-E-DATA-8-OD_B	OUT	Odd head(R) data signal 8(E)
13	GND	-	GND
14	H1-F-DATA-10-OD_B	OUT	Odd head(R) data signal 10(F)
15	GND	-	GND
16	H1-E-DATA-9-OD_B	OUT	Odd head(R) data signal 9(E)
17	GND	-	GND
18	H1-F-HE-10_B	OUT	Head(R) heat enable signal 10(F)
19	GND	-	GND
20	H1-F-DATA-11-OD_B	OUT	Odd head(R) data signal 11(F)
21	GND	-	GND
22	H1-F-HE-11_B	OUT	Head(R) heat enable signal 11(F)

J3601			
Pin Number	Signal name	IN/OUT	Function
23	GND	-	GND
24	H1-F-DATA-11-EV_B	OUT	Even head(R) data signal 11(F)
25	GND	-	GND
26	H1-F-DATA-10-EV_B	OUT	Even head(R) data signal 10(F)
27	GND	-	GND
28	H1-E-HE-9_B	OUT	Head(R) heat enable signal 9(E)
29	GND	-	GND
30	H1-E-DATA-9-EV_B	OUT	Even head(R) data signal 9(E)
31	GND	-	GND
32	VH_DIS	OUT	VH selection signal
33	H1-DASLK_LICC2	OUT	Head(R) analogue switch clock signal
34	H1-DLD_LICC2	OUT	Head(R) analogue switch latch signal
35	H1-DATA_LICC2	OUT	Head(R) analogue switch data signal
36	PWLED2_ON	OUT	multi sensor LED2 drive signal
37	PWLED1_ON	OUT	multi sensor LED1 drive signal
38	PWLED3_ON	OUT	multi sensor LED3 drive signal
39	H3V_ON	OUT	Power supply
40	MLT_SENS_1IN	IN	multi sensor signal 1
41	MLT_SENS_2IN	IN	multi sensor signal 2
42	PWLED4_ON	OUT	multi sensor LED4 drive signal
43	GND	-	GND
44	H1-B-DATA-2-OD_B	OUT	Odd head(R) data signal 2(B)
45	GND	-	GND
46	H1-B-DATA-3-OD_B	OUT	Odd head(R) data signal 3(B)
47	GND	-	GND
48	H1-C-HE-4_B	OUT	Head(R) heat enable signal 4(C)
49	GND	-	GND
50	H1-C-DATA-4-OD_B	OUT	Odd head(R) data signal 4(C)

T-6-22

J3602			
Pin Number	Signal name	IN/OUT	Function
1	IO_ASIC_SDA	IN/OUT	Head ROM controll signal(data)
2	IO_ASIC_SCL	IN/OUT	Head ROM controll signal(clock)
3	GND	-	GND
4	H1-E-DATA-8-EV_B	OUT	Even head(L) data signal 8(E)
5	OUT ENB	OUT	Head data enable signal
6	H1-D-HE-7_B	OUT	Head(L) heat enable signal 7(D)
7	GND	-	GND
8	H1-D-DATA-7-EV_B	OUT	Even head(L) data signal 7(D)
9	GND	-	GND
10	H1-D-DATA-6-EV_B	OUT	Even head(L) data signal 6(D)
11	GND	-	GND
12	H1-D-DATA-6-OD_B	OUT	Odd head(L) data signal 6(D)
13	GND	-	GND
14	H1-D-HE-6_B	OUT	Head(L) heat enable signal 6(D)
15	GND	-	GND
16	H1-C-HE-5_B	OUT	Head(L) heat enable signal 5(C)
17	GND	-	GND
18	H1-C-DATA-5-OD_B	OUT	Odd head(L) data signal 5(C)
19	GND	-	GND
20	H1-DSOUT2	OUT	Head temperature output signal 2
21	H1-DSOUT1	OUT	Head temperature output signal 1
22	GND	-	GND
23	GND	-	GND
24	H1_CLK_B	OUT	Head(L) clock signal
25	GND	-	GND
26	H1_LT_B	OUT	Head(L) latch signal
27	GND	-	GND
28	H1-C-DATA-5-EV_B	OUT	Even head(L) data signal 5(C)
29	GND	-	GND
30	H1-B-HE-3_B	OUT	Head(L) heat enable signal 3(B)
31	GND	-	GND
32	H1-C-DATA-4-EV_B	OUT	Even head(L) data signal 4(C)
33	GND	-	GND

J3602			
Pin Number	Signal name	IN/OUT	Function
34	H1-B-DATA-3-EV_B	OUT	Even head(L) data signal 3(B)
35	GND	-	GND
36	H1-B-DATA-2-EV_B	OUT	Even head(L) data signal 2(B)
37	GND	-	GND
38	H1-A-DATA-1-EV_B	OUT	Even head(L) data signal 1(A)
39	GND	-	GND
40	H1-A-HE-1_B	OUT	Head(L) heat enable signal 1(A)
41	GND	-	GND
42	H1-A-DATA-0-EV_B	OUT	Even head(L) data signal 0(A)
43	GND	-	GND
44	H1-A-HE-0_B	OUT	Head(L) heat enable signal 0(A)
45	GND	-	GND
46	H1-A-DATA-0-OD_B	OUT	Odd head(L) data signal 0(A)
47	GND	-	GND
48	H1-A-DATA-1-OD_B	OUT	Odd head(L) data signal 1(A)
49	GND	-	GND
50	H1-B-HE-2_B	OUT	Head(L) heat enable signal 2(B)

6.2.2 Carriage relay PCB

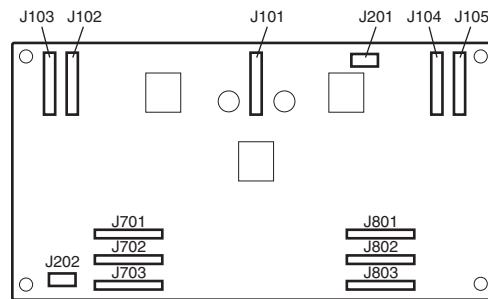

F-6-2
T-6-23

J101			
Pin Number	Signal name	IN/OUT	Function
1	VMGND	-	GND
2	VMGND	-	GND
3	VMGND	-	GND
4	VMGND	-	GND
5	VM	IN	Power supply(+32V)
6	VM	IN	Power supply(+32V)
7	VM	IN	Power supply(+32V)
8	VM	IN	Power supply(+32V)
9	VM	IN	Power supply(+32V)
10	VM	IN	Power supply(+32V)
11	VM	IN	Power supply(+32V)
12	VM	IN	Power supply(+32V)
13	SNS5V	IN	Power supply(+5V)
14	SNS5V	IN	Power supply(+5V)
15	GND	-	GND
16	+3.3V	IN	Power supply(+3.3V)
17	+3.3V	IN	Power supply(+3.3V)
18	GND	-	GND
19	VH_MONI2	OUT	VH control signal 2
20	VH_ENB	IN	VH power ON/OFF signal
21	VH_MONI1	OUT	VH control signal 1
22	VMGND	-	GND
23	VMGND	-	GND
24	VMGND	-	GND
25	VMGND	-	GND

T-6-24

J102			
Pin Number	Signal name	IN/OUT	Function
1	H1-C-DATA-4-OD_B	IN	Odd head(L) data signal 4(C)
2	GND	-	GND

J102			
Pin Number	Signal name	IN/OUT	Function
3	/H1-C-HE-4_B	IN	Head(L) heat enable signal 4(C)
4	GND	-	GND
5	H1-B-DATA-3-OD_B	IN	Odd head(L) data signal 1(B)
6	GND	-	GND
7	H1-B-DATA-2-OD_B	IN	Odd head(L) data signal 2(B)
8	GND	-	GND
9	PWLED4_ON	IN	multi sensor LED4 drive control
10	MLT_SENS_2IN	OUT	multi sensor signal 2
11	MLT_SENS_1IN	OUT	multi sensor signal 1
12	/H3V_ON	IN	Power supply
13	PWLED3_ON	IN	multi sensor LED3 drive control
14	PWLED1_ON	IN	multi sensor LED1 drive control
15	PWLED2_ON	IN	multi sensor LED2 drive control
16	H1-DATA_LICC2	IN	head(L) analogue switch data signal
17	H1-DLD_LICC2	IN	head(L) analogue switch latch signal
18	H1-DASLK_LICC2	IN	head(L) analogue switch clock signal
19	VH_DIS	IN	VH selection single
20	GND	-	GND
21	H1-E-DATA-9-EV_B	IN	Even head(L) data signal 9(E)
22	GND	-	GND
23	/H1-E-HE-9_B	IN	Head(L) heat enable signal 9(E)
24	GND	-	GND
25	H1-F-DATA-10-EV_B	IN	Even head(L) data signal 10(F)
26	GND	-	GND
27	H1-F-DATA-11-EV_B	IN	Even head(L) data signal 11(F)
28	GND	-	GND
29	/H1-F-HE-11_B	IN	Head(L) heat enable signal 11(F)
30	GND	-	GND
31	H1-F-DATA-11-OD_B	IN	Odd head(L) data signal 11(F)
32	GND	-	GND
33	/H1-F-HE-10_B	IN	Head(L) heat enable signal 10(F)
34	GND	-	GND
35	H1-E-DATA-9-OD_B	IN	Odd head(L) data signal 9(E)
36	GND	-	GND
37	H1-F-DATA-10-OD_B	IN	Odd head(L) data signal 10(F)
38	GND	-	GND
39	H1-E-DATA-8-OD_B	IN	Odd head(L) data signal 8(E)
40	GND	-	GND
41	/H1-E-HE-8_B	IN	Head(L) heat enable signal 8(E)
42	GND	-	GND
43	H1-D-DATA-7-OD_B	IN	Odd head(L) data signal 7(D)
44	GND	-	GND
45	H-DASH_LICC2	IN	Head analogue switch A/D trigger signal
46	/OUT_ENB	IN	Head data enable signal
47	/CRCOVER	OUT	Carriage cover sensor output signal
48	GND	-	GND
49	ENCODER_B	OUT	carriage encoder output signal B
50	ENCODER_A	OUT	carriage encoder output signal A

T-6-25

J103			
Pin Number	Signal name	IN/OUT	Function
1	/H1-B-HE-2_B	IN	Head(L) heat enable signal 2(B)
2	GND	-	GND
3	H1-A-DATA-1-OD_B	IN	Odd head(L) data signal 1(A)
4	GND	-	GND
5	H1-A-DATA-0-OD_B	IN	Odd head(L) data signal 0(A)
6	GND	-	GND
7	/H1-A-HE-0_B	IN	Head(L) heat enable signal 0(A)
8	GND	-	GND
9	H1-A-DATA-0-EV_B	IN	Even head(L) data signal 0(A)
10	GND	-	GND
11	/H1-A-HE-1_B	IN	Head(L) heat enable signal 1(A)
12	GND	-	GND
13	H1-A-DATA-1-EV_B	IN	Even head(L) data signal 1(A)

J103			
Pin Number	Signal name	IN/OUT	Function
14	GND	-	GND
15	H1-B-DATA-2-EV_B	IN	Even head(L) data signal 2(B)
16	GND	-	GND
17	H1-B-DATA-3-EV_B	IN	Even head(L) data signal 3(B)
18	GND	-	GND
19	H1-C-DATA-4-EV_B	IN	Even head(L) data signal 4(C)
20	GND	-	GND
21	/H1-B-HE-3_B	IN	Head(L) heat enable signal 3(B)
22	GND	-	GND
23	H1-C-DATA-5-EV_B	IN	Even head(L) data signal 5(C)
24	GND	-	GND
25	/H1_LT_B	IN	Head(L) latch signal
26	GND	-	GND
27	H1_CLKP	IN	Head(L) clock signal P
28	H1_CLKN	IN	Head(L) clock signal N
29	GND	-	GND
30	H1-DSOUT1	OUT	Head(L) temperature output signal 1
31	H1-DSOUT2	OUT	Head(L) temperature output signal 2
32	GND	-	GND
33	H1-C-DATA-5-OD_B	IN	Odd head(L) data signal 5(C)
34	GND	-	GND
35	/H1-C-HE-5_B	IN	Head(L) heat enable signal 5(C)
36	GND	-	GND
37	/H1-D-HE-6_B	IN	Head(L) heat enable signal 6(D)
38	GND	-	GND
39	H1-D-DATA-6-OD_B	IN	Odd head(L) data signal 6(D)
40	GND	-	GND
41	H1-D-DATA-6-EV_B	IN	Even head(L) data signal 6(D)
42	GND	-	GND
43	H1-D-DATA-7-EV_B	IN	Even head(L) data signal 7(D)
44	GND	-	GND
45	/H1-D-HE-7_B	IN	Head(L) heat enable signal 7(D)
46	GND	-	GND
47	H1-E-DATA-8-EV_B	IN	Even head(L) data signal 8(E)
48	GND	-	GND
49	IO_ASIC_SCL	IN/OUT	Head ROM control signal(clock)
50	IO_ASIC_SDA	IN/OUT	Head ROM control signal(data)

T-6-26

J104			
Pin Number	Signal name	IN/OUT	Function
1	GND	-	GND
2	GND	-	GND
3	VH_MONI4	OUT	VH control signal 4
4	GND	-	GND
5	GND	-	GND
6	GND	-	GND
7	H0-C-DATA-4-OD_B	IN	Odd head(R) data signal 4(C)
8	GND	-	GND
9	/H0-C-HE-4_B	IN	Head(R) heat enable signal 4(C)
10	GND	-	GND
11	H0-B-DATA-3-OD_B	IN	Odd head(R) data signal 3(B)
12	GND	-	GND
13	H0-B-DATA-2-OD_B	IN	Odd head(R) data signal 2(B)
14	GND	-	GND
15	/H0-B-HE-2_B	IN	Head(R) heat enable signal 2(B)
16	GND	-	GND
17	H0-A-DATA-1-OD_B	IN	Odd head(R) data signal 1(A)
18	GND	-	GND
19	H0-A-DATA-0-OD_B	IN	Odd head(R) data signal 0(A)
20	GND	-	GND
21	H0-DASH LICC2_B	IN	Head analogue switch A/D trigger signal
22	GND	-	GND
23	H0-E-DATA-9-EV_B	IN	Even head(R) data signal 9(E)
24	GND	-	GND

J104			
Pin Number	Signal name	IN/OUT	Function
25	/H0-E-HE-9_B	IN	Head(R) heat enable signal 9(E)
26	GND	-	GND
27	H0-F-DATA-10-EV_B	IN	Even head(R) data signal 10(F)
28	GND	-	GND
29	H0-F-DATA-11-EV_B	IN	Even head(R) data signal 11(F)
30	GND	-	GND
31	/H0-F-HE-11_B	IN	Head(R) heat enable signal 11(F)
32	GND	-	GND
33	H0-F-DATA-11-OD_B	IN	Odd head(R) data signal 11(F)
34	GND	-	GND
35	/H0-F-HE-10_B	IN	Head(R) heat enable signal 10(F)
36	GND	-	GND
37	H0-E-DATA-9-OD_B	IN	Odd head(R) data signal 9(E)
38	GND	-	GND
39	H0-F-DATA-10-OD_B	IN	Odd head(R) data signal 10(F)
40	GND	-	GND
41	H0-E-DATA-8-OD_B	IN	Odd head(R) data signal 8(E)
42	GND	-	GND
43	/H0-E-HE-8_B	IN	Head(R) heat enable signal 8(E)
44	GND	-	GND
45	H0-D-DATA-7-OD_B	IN	Odd head(R) data signal 7(D)
46	GND	-	GND
47	GND	-	GND
48	VH_MONI3	OUT	VH control signal 3
49	GND	-	GND
50	GND	-	GND

T-6-27

J105			
Pin Number	Signal name	IN/OUT	Function
1	/H0-A-HE-0_B	IN	Head(R) heat enable signal 0(A)
2	GND	-	GND
3	H0-A-DATA-0-EV_B	IN	Even head(R) data signal 0(A)
4	GND	-	GND
5	/H0-A-HE-1_B	IN	Head(R) heat enable signal 1(A)
6	GND	-	GND
7	H0-A-DATA-1-EV_B	IN	Even head(R) data signal 1(A)
8	GND	-	GND
9	H0-B-DATA-2-EV_B	IN	Even head(R) data signal 2(B)
10	GND	-	GND
11	H0-B-DATA-3-EV_B	IN	Even head(R) data signal 3(B)
12	GND	-	GND
13	H0-C-DATA-4-EV_B	IN	Even head(R) data signal 4(C)
14	GND	-	GND
15	/H0-B-HE-3_B	IN	Head(R) heat enable signal 3(B)
16	GND	-	GND
17	/LIFT_CAM_IN	OUT	Lift cam sensor output signal
18	GND	-	GND
19	H0-C-DATA-5-EV_B	IN	Even head(R) data signal 5(C)
20	GND	-	GND
21	/H0_LT_B	IN	Head(R) latch signal
22	GND	-	GND
23	H0_CLKP	IN	Head(R) clock signal P
24	H0_CLKN	IN	Head(R) clock signal N
25	GND	-	GND
26	GND	-	GND
27	H0-DASLK_LICC2	IN	Head(R) analogue switch clock signal
28	H0-DATA_LICC2	IN	Head(R) analogue switch data signal
29	H0-DLD_LICC2	IN	Head(R) analogue switch latch signal
30	GND	-	GND
31	H0-DSOUT1	OUT	Head(R) temperature output signal 1
32	GND	-	GND
33	H0-DSOUT2	OUT	Head(R) temperature output signal 2
34	GND	-	GND
35	H0-C-DATA-5-OD_B	IN	Odd head(R) data signal 5(C)

J105			
Pin Number	Signal name	IN/OUT	Function
36	GND	-	GND
37	/H0-C-HE-5_B	IN	Head(R) heat enable signal 5(C)
38	GND	-	GND
39	/H0-D-HE-6_B	IN	Head(R) heat enable signal 6(D)
40	GND	-	GND
41	H0-D-DATA-6-OD_B	IN	Odd head(R) data signal 6(D)
42	GND	-	GND
43	H0-D-DATA-6-EV_B	IN	Even head(R) data signal 6(D)
44	GND	-	GND
45	H0-D-DATA-7-EV_B	IN	Even head(R) data signal 7(D)
46	GND	-	GND
47	/H0-D-HE-7_B	IN	Head(R) heat enable signal 7(D)
48	GND	-	GND
49	H0-E-DATA-8-EV_B	IN	Even head(R) data signal 8(E)
50	GND	-	GND

T-6-28

J201			
Pin Number	Signal name	IN/OUT	Function
1	ENCODER_B	IN	Linear encoder output signal B
2	GND	-	GND
3	ENCODER_A	IN	Linear encoder output signal A
4	SNS_5V	OUT	Power supply(+5V)

T-6-29

J202			
Pin Number	Signal name	IN/OUT	Function
1	SNS_5V	OUT	Power supply(+5V)
2	GND	-	GND
3	/CRCOVER	IN	Carriage cover sensor output signal

T-6-30

J701			
Pin Number	Signal name	IN/OUT	Function
1	H3V	OUT	Power supply
2	VH1_FB	IN	VH1 feed back voltage
3	VH1	OUT	Power supply
4	VH1	OUT	Power supply
5	VH1	OUT	Power supply
6	VH1	OUT	Power supply
7	VH1	OUT	Power supply
8	VH1	OUT	Power supply
9	GND	-	GND
10	GND	-	GND
11	GND	-	GND
12	GND	-	GND
13	GND	-	GND
14	GND	-	GND
15	GND	-	GND
16	VH2	OUT	Power supply
17	VH2	OUT	Power supply
18	VH2	OUT	Power supply
19	VH2	OUT	Power supply
20	VH2	OUT	Power supply
21	VH2	OUT	Power supply
22	VH2_FB	IN	VH2 feed back voltage
23	VHT	OUT	Power supply
24	GND	-	GND
25	GND	-	GND

T-6-31

J702			
Pin Number	Signal name	IN/OUT	Function
1	GND	-	GND
2	GND	-	GND
3	GND	-	GND
4	H1-B-DATA-3-EV	OUT	Even head(L) data signal 3(B)

J702			
Pin Number	Signal name	IN/OUT	Function
5	GND	-	GND
6	/H1-B-HE-3	OUT	Head(L) heat enable signal 3(B)
7	GND	-	GND
8	H1-C-DATA-4-EV	OUT	Even head(L) data signal 4(C)
9	GND	-	GND
10	H1-C-DATA-5-EV	OUT	Even head(L) data signal 5(C)
11	GND	-	GND
12	/H1-C-HE-5	OUT	Head(L) heat enable signal 5(C)
13	GND	-	GND
14	H1-C-DATA-5-OD	OUT	Odd head(L) data signal 5(C)
15	GND	-	GND
16	H1-D-DATA-7-OD	OUT	Odd head(L) data signal 7(D)
17	GND	-	GND
18	H1-D-DATA-6-OD	OUT	Odd head(L) data signal 6(D)
19	GND	-	GND
20	/H1-D-HE-6	OUT	Head(L) heat enable signal 6(D)
21	GND	-	GND
22	H1-D-DATA-6-EV	OUT	Even head(L) data signal 6(D)
23	GND	-	GND
24	H1-D-DATA-7-EV	OUT	Even head(L) data signal 7(D)
25	GND	-	GND
26	/H1-D-HE-7	OUT	Head(L) heat enable signal 7(D)
27	GND	-	GND
28	H1-E-DATA-8-EV	OUT	Even head(L) data signal 8(E)
29	GND	-	GND
30	H1-E-DATA-9-EV		Even head(L) data signal 9(E)
31	GND	-	GND
32	/H1-E-HE-9	OUT	Head(L) heat enable signal 9(E)
33	GND	-	GND
34	H1-F-DATA-10-EV	OUT	Even head(L) data signal 10(F)
35	GND	-	GND
36	H1-F-DATA-11-EV	OUT	Even head(L) data signal 11(F)
37	GND	-	GND
38	/H1-F-HE-11	OUT	Head(L) heat enable signal 11(F)
39	GND	-	GND
40	H1-F-DATA-11-OD	OUT	Odd head(L) data signal 11(F)
41	GND	-	GND
42	H1-F-DATA-10-OD	OUT	Odd head(L) data signal 10(F)
43	GND	-	GND
44	/H1-F-HE-10	OUT	Head(L) heat enable signal 10(F)
45	GND	-	GND
46	H1-E-DATA-9-OD	OUT	Odd head(L) data signal 9(E)
47	GND	-	GND
48	H1-E-DATA-8-OD	OUT	Odd head(L) data signal 8(E)
49	GND	-	GND
50	/H1-E-HE-8	OUT	Head(L) heat enable signal 8(E)

T-6-32

J703			
Pin Number	Signal name	IN/OUT	Function
1	GND	-	GND
2	GND	OUT	Power supply(+5V)
3	GND	-	GND
4	MLT_SENS_2IN	IN	multi sensor signal 2
5	GND	-	GND
6	MLT_SENS_1IN	IN	multi sensor signal 1
7	GND	-	GND
8	H1-C-DATA-4-OD	OUT	Odd head(L) data signal 4(C)
9	GND	-	GND
10	H1-C-HE-4	OUT	Head(L) heat enable signal 4(C)
11	GND	-	GND
12	H1-B-DATA-3-OD	OUT	Odd head(L) data signal 3(B)
13	GND	-	GND
14	H1-B-DATA-2-OD	OUT	Odd head(L) data signal 2(B)
15	GND	-	GND

J703			
Pin Number	Signal name	IN/OUT	Function
16	H1-B-HE-2	OUT	Head(L) heat enable signal 2(B)
17	GND	-	GND
18	H1-A-DATA-1-OD	OUT	Odd head(L) data signal 1(A)
19	GND	-	GND
20	H1-A-DATA-0-OD	OUT	Odd head(L) data signal 0(A)
21	GND	-	GND
22	H1-A-HE-0	OUT	Head(L) heat enable signal 0(A)
23	GND	-	GND
24	H1-A-DATA-0-EV	OUT	Even head(L) data signal 0(A)
25	GND	-	GND
26	H1-A-DATA-1-EV	OUT	Even head(L) data signal 1(A)
27	GND	-	GND
28	H1-A-HE-1	OUT	Head(L) heat enable signal 1(A)
29	GND	-	GND
30	H1-B-DATA-2-EV	OUT	Even head(L) data signal 2(B)
31	GND	-	GND
32	IO_ASIC_SDA	IN/OUT	Head ROM control signal(data)
33	GND	-	GND
34	IO_ASIC_SCL	OUT	Head ROM control signal(clock)
35	GND	-	GND
36	H1_LT	OUT	Head(L) latch signal
37	GND	-	GND
38	H1_CLK	OUT	Head(L) clock signal
39	GND	-	GND
40	H1-DSOUT1	IN	Head(L) temperature output signal 1
41	GND	-	GND
42	H1-DSOUT2	IN	Head(L) temperature output signal 2
43	GND	-	GND
44	H1-DLD_LICC2	OUT	Head(L) analogue switch latch signal
45	GND	-	GND
46	H1-DATA_LICC2	OUT	Head(L) analogue switch data signal
47	GND	-	GND
48	H1-DASLK_LICC2	OUT	Head(L) analogue switch clock signal
49	GND	-	GND
50	H-DASH_LICC2	OUT	Head analogue switch A/D trigger signal

T-6-33

J801			
Pin Number	Signal name	IN/OUT	Function
1	GND	-	GND
2	GND	-	GND
3	VH3_FB	IN	VH3 feed back voltage
4	VH3	OUT	Power supply
5	VH3	OUT	Power supply
6	VH3	OUT	Power supply
7	VH3	OUT	Power supply
8	VH3	OUT	Power supply
9	VH3	OUT	Power supply
10	GND	-	GND
11	GND	-	GND
12	GND	-	GND
13	GND	-	GND
14	GND	-	GND
15	GND	-	GND
16	GND	-	GND
17	VH4	OUT	Power supply
18	VH4	OUT	Power supply
19	VH4	OUT	Power supply
20	VH4	OUT	Power supply
21	VH4	OUT	Power supply
22	VH4	OUT	Power supply
23	VH4_FB	IN	VH4 feed back voltage
24	VHT	OUT	Power supply
25	H3V	OUT	Power supply

T-6-34

J802			
Pin Number	Signal name	IN/OUT	Function
1	GND	-	GND
2	H0-B-DATA-2-EV	OUT	Even head(R) data signal 2(B)
3	GND	-	GND
4	H0-B-DATA-3-EV	OUT	Even head(R) data signal 3(B)
5	GND	-	GND
6	H0-B-HE-3	OUT	Head(R) heat enable signal 3(B)
7	GND	-	GND
8	H0-C-DATA-4-EV	OUT	Even head(R) data signal 4(C)
9	GND	-	GND
10	H0-C-DATA-5-EV	OUT	Even head(R) data signal 5(C)
11	GND	-	GND
12	H0-C-HE-5	OUT	Head(R) heat enable signal 5(C)
13	GND	-	GND
14	H0-C-DATA-5-OD	OUT	Odd head(R) data signal 5(C)
15	GND	-	GND
16	H0-D-DATA-7-OD	OUT	Odd head(R) data signal 7(D)
17	GND	-	GND
18	H0-D-DATA-6-OD	OUT	Odd head(R) data signal 6(D)
19	GND	-	GND
20	H0-D-HE-6	OUT	Head(R) heat enable signal 6(D)
21	GND	-	GND
22	H0-D-DATA-6-EV	OUT	Even head(R) data signal 6(D)
23	GND	-	GND
24	H0-D-DATA-7-EV	OUT	Even head(R) data signal 7(D)
25	GND	-	GND
26	H0-D-HE-7	OUT	Head(R) heat enable signal 7(D)
27	GND	-	GND
28	H0-E-DATA-8-EV	OUT	Even head(R) data signal 8(E)
29	GND	-	GND
30	H0-E-DATA-9-EV	OUT	Even head(R) data signal 9(E)
31	GND	-	GND
32	H0-E-HE-9	OUT	Head(R) heat enable signal 9(E)
33	GND	-	GND
34	H0-F-DATA-10-EV	OUT	Even head(R) data signal 10(F)
35	GND	-	GND
36	H0-F-DATA-11-EV	OUT	Even head(R) data signal 11(F)
37	GND	-	GND
38	H0-F-HE-11	OUT	Head(R) heat enable signal 11(F)
39	GND	-	GND
40	H0-F-DATA-11-OD	OUT	Odd head(R) data signal 11(F)
41	GND	-	GND
42	H0-F-DATA-10-OD	OUT	Odd head(R) data signal 10(F)
43	GND	-	GND
44	H0-F-HE-10	OUT	Head(R) heat enable signal 10(F)
45	GND	-	GND
46	H0-E-DATA-9-OD	OUT	Odd head(R) data signal 9(E)
47	GND	-	GND
48	H0-E-DATA-8-OD	OUT	Odd head(R) data signal 8(E)
49	GND	-	GND
50	H0-E-HE-8	OUT	Head(R) heat enable signal 8(E)

T-6-35

J803			
Pin Number	Signal name	IN/OUT	Function
1	GND	-	GND
2	SNS_5V	OUT	Power supply(+5V)
3	GND	-	GND
4	PWLED4	OUT	Multi sensor LED4 drive signal
5	GND	-	GND
6	PWLED3	OUT	Multi sensor LED3 drive signal
7	GND	-	GND
8	PWLED2	OUT	Multi sensor LED2 drive signal
9	GND	-	GND
10	PWLED1	OUT	Multi sensor LED1 drive signal
11	GND	-	GND

J803			
Pin Number	Signal name	IN/OUT	Function
12	H0-DASH_LICC2	OUT	Head analogue switch A/D trigger signal
13	GND	-	GND
14	H0-DLD_LICC2	OUT	Head(R) analogue switch latch signal
15	GND	-	GND
16	H0-DATA_LICC2	OUT	Head(R) analogue switch data signal
17	GND	-	GND
18	H0-DASLK_LICC2	OUT	Head(R) analogue switch clock signal
19	GND	-	GND
20	H0-DSOUT1	IN	Head(R) temperature output signal 1
21	GND	-	GND
22	H0-DSOUT2	IN	Head(R) temperature output signal 2
23	GND	-	GND
24	H0-C-DATA-4-OD	OUT	Odd head(R) data signal 4(C)
25	GND	-	GND
26	H0-C-HE-4	OUT	Head(R) heat enable signal 4(C)
27	GND	-	GND
28	H0-B-DATA-3-OD	OUT	Odd head(R) data signal 3(B)
29	GND	-	GND
30	H0-B-DATA-2-OD	OUT	Odd head(R) data signal 2(B)
31	GND	-	GND
32	H0-B-HE-2	OUT	Head(R) heat enable signal 2(B)
33	GND	-	GND
34	H0-A-DATA-1-OD	OUT	Odd head(R) data signal 1(A)
35	GND	-	GND
36	H0-A-DATA-0-OD	OUT	Odd head(R) data signal 0(A)
37	GND	-	GND
38	H0-A-HE-0	OUT	Head(R) heat enable signal 0(A)
39	GND	-	GND
40	H0-A-DATA-0-EV	OUT	Even head(R) data signal 0(A)
41	GND	-	GND
42	H0-A-DATA-1-EV	OUT	Even head(R) data signal 1(A)
43	GND	-	GND
44	H0-A-HE-1	OUT	Head(R) heat enable signal 1(A)
45	GND	-	GND
46	H0_LT	OUT	Head(R) latch signal
47	GND	-	GND
48	H0_CLK	OUT	Head(R) clock signal
49	GND	-	GND
50	LIFT_CAM_IN	IN	Lift cam sensor output signal

6.2.3 Head relay PCB

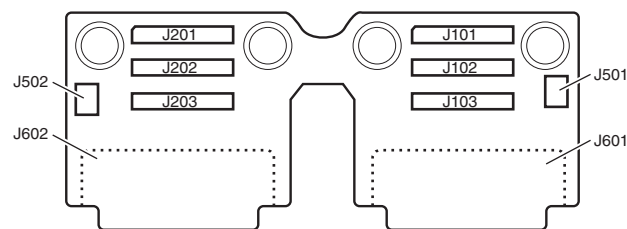

F-6-3
T-6-36

J101			
Pin Number	Signal name	IN/OUT	Function
1	GND	-	GND
2	GND	-	GND
3	VHT12	IN	Power supply
4	VH2_FB	IN	VH2 feed back voltage
5	VH2	IN	Power supply
6	VH2	IN	Power supply
7	VH2	IN	Power supply
8	VH2	IN	Power supply
9	VH2	IN	Power supply
10	VH2	IN	Power supply
11	GND	-	GND

J101			
Pin Number	Signal name	IN/OUT	Function
12	GND	-	GND
13	GND	-	GND
14	GND	-	GND
15	GND	-	GND
16	GND	-	GND
17	GND	-	GND
18	VH1	IN	Power supply
19	VH1	IN	Power supply
20	VH1	IN	Power supply
21	VH1	IN	Power supply
22	VH1	IN	Power supply
23	VH1	IN	Power supply
24	VH1_FB	IN	VH1 feed back voltage
25	H3V	IN	Power supply

T-6-37

J102			
Pin Number	Signal name	IN/OUT	Function
1	H1-E-HE-8	IN	Head(L) heat enable signal 8(E)
2	GND	-	GND
3	H1-E-DATA-8-OD	IN	Odd head(L) data signal 8(E)
4	GND	-	GND
5	H1-E-DATA-9-OD	IN	Odd head(L) data signal 9(E)
6	GND	-	GND
7	H1-F-HE-10	IN	Head(L) heat enable signal 10(F)
8	VH2	-	GND
9	H1-F-DATA-10-OD	IN	Odd head(L) data signal 10(F)
10	GND	-	GND
11	H1-F-DATA-11-OD	IN	Odd head(L) data signal 11(F)
12	GND	-	GND
13	H1-F-HE-11	IN	Head(L) heat enable signal 11(F)
14	GND	-	GND
15	H1-F-DATA-11-EV	IN	Even head(L) data signal 11(F)
16	GND	-	GND
17	H1-F-DATA-10-EV	IN	Even head(L) data signal 10(F)
18	GND	-	GND
19	H1-E-HE-9	IN	Head(L) heat enable signal 9(E)
20	GND	-	GND
21	H1-E-DATA-9-EV	0	Even head(L) data signal 9(E)
22	GND	-	GND
23	H1-E-DATA-8-EV	IN	Even head(L) data signal 8(E)
24	GND	-	GND
25	H1-D-HE-7	IN	Head(L) heat enable signal 7(D)
26	GND	-	GND
27	H1-D-DATA-7-EV	IN	Even head(L) data signal 7(D)
28	GND	-	GND
29	H1-D-DATA-6-EV	IN	Even head(L) data signal 6(D)
30	GND	-	GND
31	H1-D-HE-6	IN	Head(L) heat enable signal 6(D)
32	GND	-	GND
33	H1-D-DATA-6-OD	IN	Odd head(L) data signal 6(D)
34	GND	-	GND
35	H1-D-DATA-7-OD	IN	Odd head(L) data signal 7(D)
36	GND	-	GND
37	H1-C-DATA-5-OD	IN	Odd head(L) data signal 5(C)
38	GND	-	GND
39	H1-C-HE-5	IN	Head(L) heat enable signal 5(C)
40	GND	-	GND
41	H1-C-DATA-5-EV	IN	Even head(L) data signal 5(C)
42	GND	-	GND
43	H1-C-DATA-4-EV	IN	Even head(L) data signal 4(C)
44	GND	-	GND
45	H1-B-HE-3	IN	Head(L) heat enable signal 3(B)
46	GND	-	GND
47	H1-B-DATA-3-EV	IN	Even head(L) data signal 3(B)

J102			
Pin Number	Signal name	IN/OUT	Function
48	GND	-	GND
49	GND	-	GND
50	GND	-	GND

T-6-38

J103			
Pin Number	Signal name	IN/OUT	Function
1	H-DASH_LICC2	IN	Head analogue switch A/D trigger signal
2	GND	-	GND
3	H1-DASLK_LICC2	IN	Head(L) analogue switch clock signal
4	GND	-	GND
5	H1-DATA_LICC2	IN	Head(L) analogue switch data signal
6	GND	-	GND
7	H1-DLD_LICC2	IN	Head(L) analogue switch latch signal
8	VH2	-	GND
9	H1-DSOUT2	OUT	Head(L) temperature output signal 2
10	GND	-	GND
11	H1-DSOUT1	OUT	Head(L) temperature output signal 1
12	GND	-	GND
13	H1_CLK	IN	Head(L) clock signal
14	GND	-	GND
15	H1_LT	IN	Head(L) latch signal
16	GND	-	GND
17	IO_ASIC_SCL	IN/OUT	Head ROM control signal(clock)
18	GND	-	GND
19	IO_ASIC_SDA	IN/OUT	Head ROM control signal(data)
20	GND	-	GND
21	H1-B-DATA-2-EV	IN	Even head(L) data signal 2(B)
22	GND	-	GND
23	H1-A-HE-1	IN	Head(L) heat enable signal 1(A)
24	GND	-	GND
25	H1-A-DATA-1-EV	IN	Even head(L) data signal 1(A)
26	GND	-	GND
27	H1-A-DATA-0-EV	IN	Even head(L) data signal 0(A)
28	GND	-	GND
29	H1-A-HE-0	IN	Head(L) heat enable signal 0(A)
30	GND	-	GND
31	H1-A-DATA-0-OD	IN	Odd head(L) data signal 0(A)
32	GND	-	GND
33	H1-A-DATA-1-OD	IN	Odd head(L) data signal 1(A)
34	GND	-	GND
35	H1-B-HE-2	IN	Head(L) heat enable signal 2(B)
36	GND	-	GND
37	H1-B-DATA-2-OD	IN	Odd head(L) data signal 2(B)
38	GND	-	GND
39	H1-B-DATA-3-OD	IN	Odd head(L) data signal 3(B)
40	GND	-	GND
41	H1-C-HE-4	IN	Head(L) heat enable signal 4(C)
42	GND	-	GND
43	H1-C-DATA-4-OD	IN	Odd head(L) data signal 4(C)
44	GND	-	GND
45	MLT_SENS_1IN	OUT	Multi sensor signal 1
46	GND	-	GND
47	MLT_SENS_2IN	OUT	Multi sensor signal 2
48	GND	-	GND
49	SNS5V	IN	Power supply(+5V)
50	GND	-	GND

T-6-39

J201			
Pin Number	Signal name	IN/OUT	Function
1	H3V	IN	Power supply
2	VHT34	IN	Power supply
3	VH4_FB	OUT	VH4 feed back voltage
4	VH4	IN	Power supply
5	VH4	IN	Power supply

J201			
Pin Number	Signal name	IN/OUT	Function
6	VH4	IN	Power supply
7	VH4	IN	Power supply
8	VH2	IN	Power supply
9	VH4	IN	Power supply
10	GND	-	GND
11	GND	-	GND
12	GND	-	GND
13	GND	-	GND
14	GND	-	GND
15	GND	-	GND
16	GND	-	GND
17	VH3	IN	Power supply
18	VH3	IN	Power supply
19	VH3	IN	Power supply
20	VH3	IN	Power supply
21	VH3	IN	Power supply
22	VH3	IN	Power supply
23	VH3_FB	IN	VH3 feed back voltage
24	GND	-	GND
25	GND	-	GND

T-6-40

J202			
Pin Number	Signal name	IN/OUT	Function
1	H0-E-HE-8	IN	Head(R) heat enable signal 8(E)
2	GND	-	GND
3	H0-E-DATA-8-OD	IN	Odd head(R) data signal 8(E)
4	GND	-	GND
5	H0-E-DATA-9-OD	IN	Odd head(R) data signal 9(E)
6	GND	-	GND
7	H0-F-HE-10	IN	Head(R) heat enable signal 10(F)
8	VH2	-	GND
9	H0-F-DATA-10-OD	IN	Odd head(R) data signal 10(F)
10	GND	-	GND
11	H0-F-DATA-11-OD	IN	Odd head(R) data signal 11(F)
12	GND	-	GND
13	H0-F-HE-11	IN	Head(R) heat enable signal 11(F)
14	GND	-	GND
15	H0-F-DATA-11-EV	IN	Even head(R) data signal 11(F)
16	GND	-	GND
17	H0-F-DATA-10-EV	IN	Even head(R) data signal 10(F)
18	GND	-	GND
19	H0-E-HE-9	IN	Head(R) heat enable signal 9(E)
20	GND	-	GND
21	H0-E-DATA-9-EV	IN	Even head(R) data signal 9(E)
22	GND	-	GND
23	H0-E-DATA-8-EV	IN	Even head(R) data signal 8(E)
24	GND	-	GND
25	H0-D-HE-7	IN	Head(R) heat enable signal 7(D)
26	GND	-	GND
27	H0-D-DATA-7-EV	IN	Even head(R) data signal 7(D)
28	GND	-	GND
29	H0-D-DATA-6-EV	IN	Even head(R) data signal 6(D)
30	GND	-	GND
31	H0-D-HE-6	IN	Head(R) heat enable signal 6(D)
32	GND	-	GND
33	H0-D-DATA-6-OD	IN	Odd head(R) data signal 6(D)
34	GND	-	GND
35	H0-D-DATA-7-OD	IN	Odd head(R) data signal 7(D)
36	GND	-	GND
37	H0-C-DATA-5-OD	IN	Odd head(R) data signal 5(C)
38	GND	-	GND
39	H0-C-HE-5	IN	Head(R) heat enable signal 5(C)
40	GND	-	GND
41	H0-C-DATA-5-EV	IN	Even head(R) data signal 5(C)

J202			
Pin Number	Signal name	IN/OUT	Function
42	GND	-	GND
43	H0-C-DATA-4-EV	IN	Even head(R) data signal 4(C)
44	GND	-	GND
45	H0-B-HE-3	IN	Head(R) heat enable signal 3(B)
46	GND	-	GND
47	H0-B-DATA-3-EV	IN	Even head(R) data signal 3(B)
48	GND	-	GND
49	H0-B-DATA-2-EV	IN	Even head(R) data signal 2(B)
50	GND	-	GND

T-6-41

J203			
Pin Number	Signal name	IN/OUT	Function
1	LIFT_CAM_IN	OUT	Lift cam sensor output signal
2	GND	-	GND
3	H0_CLK	IN	Head(R) clock signal
4	GND	-	GND
5	H0_LT	IN	Head(R) latch signal
6	GND	-	GND
7	H0-A-HE-1	IN	Head(R) heat enable signal 1(A)
8	VH2	-	GND
9	H0-A-DATA-1-EV	IN	Even head(R) data signal 1(A)
10	GND	-	GND
11	H0-A-DATA-0-EV	IN	Even head(R) data signal 0(A)
12	GND	-	GND
13	H0-A-HE-0	IN	Head(R) heat enable signal 0(A)
14	GND	-	GND
15	H0-A-DATA-0-OD	IN	Odd head(R) data signal 0(A)
16	GND	-	GND
17	H0-A-DATA-1-OD	IN	Odd head(R) data signal 1(A)
18	GND	-	GND
19	H0-B-HE-2	IN	Head(R) heat enable signal 2(B)
20	GND	-	GND
21	H0-B-DATA-2-OD	IN	Odd head(R) data signal 2(B)
22	GND	-	GND
23	H0-B-DATA-3-OD	IN	Odd head(R) data signal 3(B)
24	GND	-	GND
25	H0-C-HE-4	IN	Head(R) heat enable signal 4(C)
26	GND	-	GND
27	H0-C-DATA-4-OD	IN	Odd head(R) data signal 4(C)
28	GND	-	GND
29	H0-DSOUT2	OUT	Head(R) temperature output signal 2
30	GND	-	GND
31	H0-DSOUT1	OUT	Head(R) temperature output signal 1
32	GND	-	GND
33	H0-DASLK_LICC2	IN	Head(R) analogue switch clock signal
34	GND	-	GND
35	H0-DATA_LICC2	IN	Head(R) analogue switch data signal
36	GND	-	GND
37	H0-DLD_LICC2	IN	Head(R) analogue switch latch signal
38	GND	-	GND
39	H-DASH LICC2	IN	Head analogue switch A/D trigger signal
40	GND	-	GND
41	PWLED1_ON	IN	multi sensor LED1 drive signal
42	GND	-	GND
43	PWLED2_ON	IN	multi sensor LED2 drive signal
44	GND	-	GND
45	PWLED3_ON	IN	multi sensor LED3 drive signal
46	GND	-	GND
47	PWLED4_ON	IN	multi sensor LED4 drive signal
48	GND	-	GND
49	SNS_5V	IN	Power supply(+5V)
50	GND	-	GND

T-6-42

J501			
Pin Number	Signal name	IN/OUT	Function
1	PWLED1	OUT	Multi sensor LED1 drive signal
2	PWLED2	OUT	Multi sensor LED2 drive signal
3	PWLED3	OUT	Multi sensor LED3 drive signal
4	PWLED4	OUT	Multi sensor LED4 drive signal
5	GND	-	GND
6	MLT_SNS_1IN	IN	Multi sensor signal 1
7	MLT_SNS_2IN	IN	Multi sensor signal 2
8	VH2	OUT	Power supply

T-6-43

J502			
Pin Number	Signal name	IN/OUT	Function
1	SNS5V_0	OUT	Power supply(+5V)
2	GND	-	GND
3	LIFT_CAM_IN	IN	Lift cam sensor output signal

T-6-44

J601			
Pin Number	Signal name	IN/OUT	Function
1	VH2	OUT	Power supply
2	VH2	OUT	Power supply
3	VH2	OUT	Power supply
4	VHT12	OUT	Head transistor drive power supply
5	H1-F-DATA-10-EV	OUT	Even head(L) data signal 10(F)
6	IO_ASIC_SDA	IN/OUT	Head ROM control signal(data)
7	IO_ASIC_SCL	OUT	Head ROM control signal(clock)
8	VH2	OUT	Power supply
9	H1-C-DIA1	IN	Head(L) DI sensor signal 1(C)
10	H1-A-HE-1	OUT	Head(L) heat enable signal 1(A)
11	VH1	OUT	Power supply
12	VH1	OUT	Power supply
13	VH1	OUT	Power supply
14	VH2	OUT	Power supply
15	VH2	OUT	Power supply
16	H1-E-DATA-9-OD	OUT	Odd head(R) data signal 9(E)
17	H1-F-HE-11	OUT	Head(L) heat enable signal 11(F)
18	H1-E-DIA1	IN	Head(L) DI sensor signal 1(E)
19	H1-D-DIA1	IN	Head(L) DI sensor signal 1(D)
20	H3V_1	OUT	Power supply
21	H3V_1	OUT	Power supply
22	H1-B-DATA-3-EV	OUT	Even head(L) data signal 3(B)
23	H1-A-DATA-0-EV	OUT	Even head(L) data signal 0(A)
24	H1-B-HE-2	OUT	Head(L) heat enable signal 2(B)
25	VH1	OUT	Power supply
26	VH1	OUT	Power supply
27	H1-D-DIA2	IN	Head(L) DI sensor signal 2(D)
28	H1-E-HE-8	OUT	Head(L) heat enable signal 8(E)
29	H1-E-DIA2	IN	Head(L) DI sensor signal 2(E)
30	H1-F-DIA2	IN	Head(L) DI sensor signal 2(F)
31	H1-E-HE-9	OUT	Head(L) heat enable signal 9(E)
32	H1-D-DATA-7-EV	OUT	Even head(L) data signal 7(D)
33	H1-D-HE-6	OUT	Head(L) heat enable signal 6(D)
34	H1-C-DATA-5-OD	OUT	Odd head(R) data signal 5(C)
35	H1-C-DATA-4-EV	OUT	Even head(L) data signal 4(C)
36	H1-A-DATA-1-EV	OUT	Even head(L) data signal 1(A)
37	H1-A-DIA2	IN	Head(L) DI sensor signal 2(A)
38	H1-B-DIA2	IN	Head(L) DI sensor signal 2(B)
39	H1-C-HE-4	OUT	Head(L) heat enable signal 4(C)
40	H1-D-DATA-7-OD	OUT	Odd head(R) data signal 7(D)
41	H1-E-DATA-8-OD	OUT	Odd head(R) data signal 8(E)
42	H1-F-HE-10	OUT	Head(L) heat enable signal 10(F)
43	H1-F-DATA-11-EV	OUT	Even head(L) data signal 11(F)
44	H1-E-DATA-8-EV	OUT	Even head(L) data signal 8(E)
45	H1-D-DATA-6-EV	OUT	Even head(L) data signal 6(D)
46	H1-C-DIA2	IN	Head(L) DI sensor signal 2(C)

J601			
Pin Number	Signal name	IN/OUT	Function
47	H1-C-DATA-5-EV	OUT	Even head(L) data signal 5(C)
48	H1-B-DIA1	IN	Head(L) DI sensor signal 1(B)
49	H1-A-HE-0	OUT	Head(L) heat enable signal 0(A)
50	H1-B-DATA-2-OD	OUT	Odd head(R) data signal 2(B)
51	H1-B-DATA-3-OD	OUT	Odd head(R) data signal 3(B)
52	H1-C-DATA-4-OD	OUT	Odd head(R) data signal 4(C)
53	GND	-	GND
54	GND	-	GND
55	GND	-	GND
56	H1-F-DATA-11-OD	OUT	Odd head(R) data signal 11(F)
57	H1-E-DATA-9-EV	OUT	Even head(L) data signal 9(E)
58	GND	-	GND
59	H1-D-DATA-6-OD	OUT	Odd head(L) data signal 6(D)
60	H1-C-HE-5	OUT	Head(L) heat enable signal 5(C)
61	H1-B-HE-3	OUT	Head(L) heat enable signal 3(B)
62	H1-A-DIA1	IN	Head(L) DI sensor signal 1(A)
63	H1-A-DATA-1-OD	OUT	Odd head(R) data signal 1(A)
64	GND	-	GND
65	GND	-	GND
66	GND	-	GND
67	GND	-	GND
68	H1-F-DATA-10-OD	OUT	Odd head(R) data signal 10(F)
69	H1-F-DIA1	IN	Head(L) DI sensor signal 1(F)
70	H1-D-HE-7	OUT	Head(L) heat enable signal 7(D)
71	GND	-	GND
72	H1_CLK	OUT	Head(L) clock signal
73	H1_LT	OUT	Head(L) clock signal
74	H1-B-DATA-2-EV	OUT	Even head(L) data signal 2(B)
75	H1-A-DATA-0-OD	OUT	Odd head(R) data signal 0(A)
76	GND	-	GND
77	GND	-	GND
78	GND	-	GND

T-6-45

J602			
Pin Number	Signal name	IN/OUT	Function
1	VH3	OUT	Power supply
2	VH3	OUT	Power supply
3	VH3	OUT	Power supply
4	VHT34	OUT	Power supply
5	H0-F-DATA-10-EV	OUT	Even head(R) data signal 10(F)
6	IO_ASIC_SDA	IN/OUT	Head ROM control signal(data)
7	IO_ASIC_SCL	OUT	Head ROM control signal(clock)
8	VH2	OUT	Power supply
9	H0-C-DIA1	IN	Head(R) DI sensor signal 1(C)
10	H0-A-HE-1	OUT	Head(R) heat enable signal 1(A)
11	VH3	OUT	Power supply
12	VH3	OUT	Power supply
13	VH3	OUT	Power supply
14	VH4	OUT	Power supply
15	VH4	OUT	Power supply
16	H0-E-DATA-9-OD	OUT	Odd head(R) data signal 9(E)
17	H0-F-HE-11	OUT	Head(R) heat enable signal 11(F)
18	H0-E-DIA1	IN	Head(R) DI sensor signal 1(E)
19	H0-D-DIA1	IN	Head(R) DI sensor signal 1(D)
20	H3V_0	OUT	Power supply
21	H3V_0	OUT	Power supply
22	H0-B-DATA-3-EV	OUT	Even head(R) data signal 3(B)
23	H0-A-DATA-0-EV	OUT	Even head(R) data signal 0(A)
24	H0-B-HE-2	OUT	Head(R) heat enable signal 2(B)
25	VH3	OUT	Power supply
26	VH3	OUT	Power supply
27	H0-D-DIA2	IN	Head(R) DI sensor signal 2(D)
28	H0-E-HE-8	OUT	Head(R) heat enable signal 8(E)
29	H0-E-DIA2	IN	Head(R) DI sensor signal 2(E)

J602			
Pin Number	Signal name	IN/OUT	Function
30	H0-F-DIA2	IN	Head(R) DI sensor signal 2(E)
31	H0-E-HE-9	OUT	Head(R) heat enable signal 9(E)
32	H0-D-DATA-7-EV	OUT	Even head(R) data signal 7(D)
33	H0-D-HE-6	OUT	Head(R) heat enable signal 6(D)
34	H0-C-DATA-5-OD	OUT	Odd head(R) data signal 5(C)
35	H0-C-DATA-4-EV	OUT	Even head(R) data signal 4(C)
36	H0-A-DATA-1-EV	OUT	Even head(R) data signal 1(A)
37	H0-A-DIA2	IN	Head(R) DI sensor signal 2(A)
38	H0-B-DIA2	IN	Head(R) DI sensor signal 2(B)
39	H0-C-HE-4	OUT	Head(R) heat enable signal 4(C)
40	H0-D-DATA-7-OD	OUT	Odd head(R) data signal 7(D)
41	H0-E-DATA-8-OD	OUT	Odd head(R) data signal 8(E)
42	H0-F-HE-10	OUT	Head(R) heat enable signal 10(F)
43	H0-F-DATA-11-EV	OUT	Even head(R) data signal 11(F)
44	H0-E-DATA-8-EV	OUT	Even head(R) data signal 8(E)
45	H0-D-DATA-6-EV	OUT	Even head(R) data signal 6(D)
46	H0-C-DIA2	IN	Head(R) DI sensor signal 2(C)
47	H0-C-DATA-5-EV	OUT	Even head(R) data signal 5(C)
48	H0-B-DIA1	IN	Head(R) DI sensor signal 1(B)
49	H0-A-HE-0	OUT	Head(R) heat enable signal 0(A)
50	H0-B-DATA-2-OD	OUT	Odd head(R) data signal 2(B)
51	H0-B-DATA-3-OD	OUT	Odd head(R) data signal 3(B)
52	H0-C-DATA-4-OD	OUT	Odd head(R) data signal 4(C)
53	GND	-	GND
54	GND	-	GND
55	GND	-	GND
56	H0-F-DATA-11-OD	OUT	Odd head(R) data signal 11(F)
57	H0-E-DATA-9-EV	OUT	Even head(R) data signal 9(E)
58	GND	-	GND
59	H0-D-DATA-6-OD	OUT	Odd head(R) data signal 6(D)
60	H0-C-HE-5	OUT	Head(R) heat enable signal 5(C)
61	H0-B-HE-3	OUT	Head(R) heat enable signal 3(B)
62	H0-A-DIA1	IN	Head(R) DI sensor signal 1(A)
63	H0-A-DATA-1-OD	OUT	Odd head(R) data signal 1(A)
64	GND	-	GND
65	GND	-	GND
66	GND	-	GND
67	GND	-	GND
68	H0-F-DATA-10-OD	OUT	Odd head(R) data signal 10(F)
69	H0-F-DIA1	IN	Head(R) DI sensor signal 1(F)
70	H0-D-HE-7	OUT	Head(R) heat enable signal 7(D)
71	GND	-	GND
72	H0_CLK	OUT	Head(R) clock signal
73	H0_LT	OUT	Head(R) latch signal
74	H0-B-DATA-2-EV	OUT	Even head(R) data signal 2(B)
75	H0-A-DATA-0-OD	OUT	Odd head(R) data signal 0(A)
76	GND	-	GND
77	GND	-	GND
78	GND	-	GND

6.3 Version Up

6.3.1 Firmware Update Tool

Use of the following tools allows you to update the firmware of the main controller incorporated in the printer.

- GARO Firmware Update Tool
- L Printer Service Tool

1. GARO Firmware Update Tool

GARO Firmware Update Tool is the same as that for user.

Procedure

- 1) Start GARO Firmware Update Tool.
- 2) Place the printer in the online mode.
- 3) Transfer the firmware data to the printer according to the instructions shown on the display.
- 4) The data shown on the LCD on the operation panel changes and the firmware is updated automatically.
- 5) When firmware update is completed, the printer will start again.

File transfer route:

USB, IEEE1394, network

2. L Printer Service Tool

Procedure

- 1) Start L Printer Service Tool.
- 2) Place the printer in the online mode.
- 3) Specify the firmware file(jdl) and then transfer it.
- 4) The data shown on the LCD on the operation panel changes and the firmware is updated automatically.
- 5) When firmware update is completed, the printer will start again.

File transfer route:

USB, IEEE1394, network (directly connected using a cross cable)

6.4 Service Tools

6.4.1 List of Tools

T-6-46

General-purpose tools	Application
Long phillips scerewdriver	Inserting and removing screw
Phillips scerewdriver	Inserting and removing screw
Flat-head scerewdriver	Removing the E-ring
Needle-nose pliers	Inserting and removing the spring parts
Hex key wrench	Inserting and removing hexagonal screws
Flat brush	Applying grease
Lint free paper	Wiping off ink
Rubber gloves	Preventing ink stains

T-6-47

Special-purpose tools	Application
Grease MOLYKOTE PG-641 (CK-0562-000)	Applying to specified locations
Grease PERMALUBE G-2 (CK-0551-020)	Applying to specified locations
Cover switch tool (QY9-0103-000)	Pressing the cover switch

Chapter 7 SERVICE MODE

Contents

7.1 Service Mode	7-1
7.1.1 Service Mode	7-1
7.1.2 Map of the Service mode	7-1
7.1.3 Details for Service mode.....	7-6
7.2 Special Mode.....	7-12
7.2.1 Special Modes for Servicing.....	7-12

7.1 Service Mode

7.1.1 Service Mode

a. How to enter the Service mode

Enter the Service mode following the procedure below.

- 1) Turn off the printer.
- 2) Turn on the printer while holding down the [Paper Source]key and [Information]key.
- 3) "S" will be displayed in the upper right corner of the display showing the firmware version of the printer.
- 4) After display of "Online", pressing the [Menu] key displays the SERVICE MODE top menu and the MESSAGE LED flashes.

* The Service mode is added to the options in the Main menu. The Service mode can be entered even in the error status(when an error message is shown on the display)by turning the power off and then using the above key operation.

b. How to exit the Service mode

Turn off the printer.

c. Key operation in the service mode

- Selecting menus and parameters:[◀] or [▶] key
- Going to the next lower-level menu:[▼] key
- Going to the previous higher-level menu:[▲] key
- Determining a selected menu or parameter:[OK] key

7.1.2 Map of the Service mode

The hierarchy of menus and parameters in the Service mode is shown below.

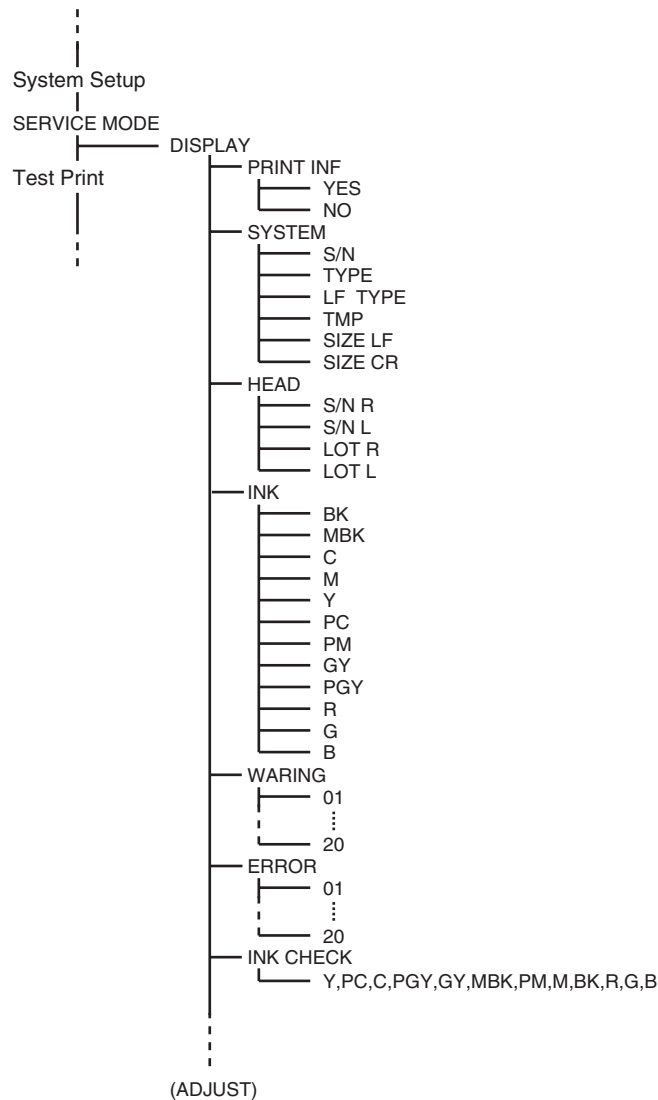

F-7-1

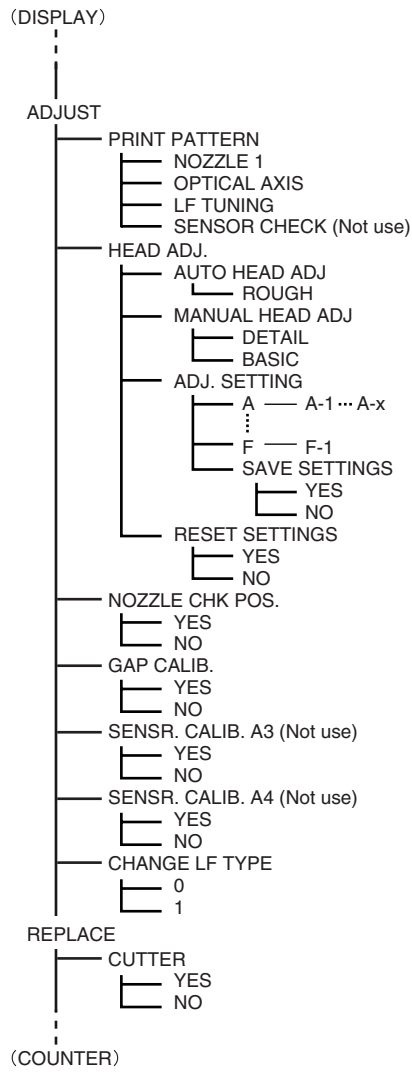

F-7-2

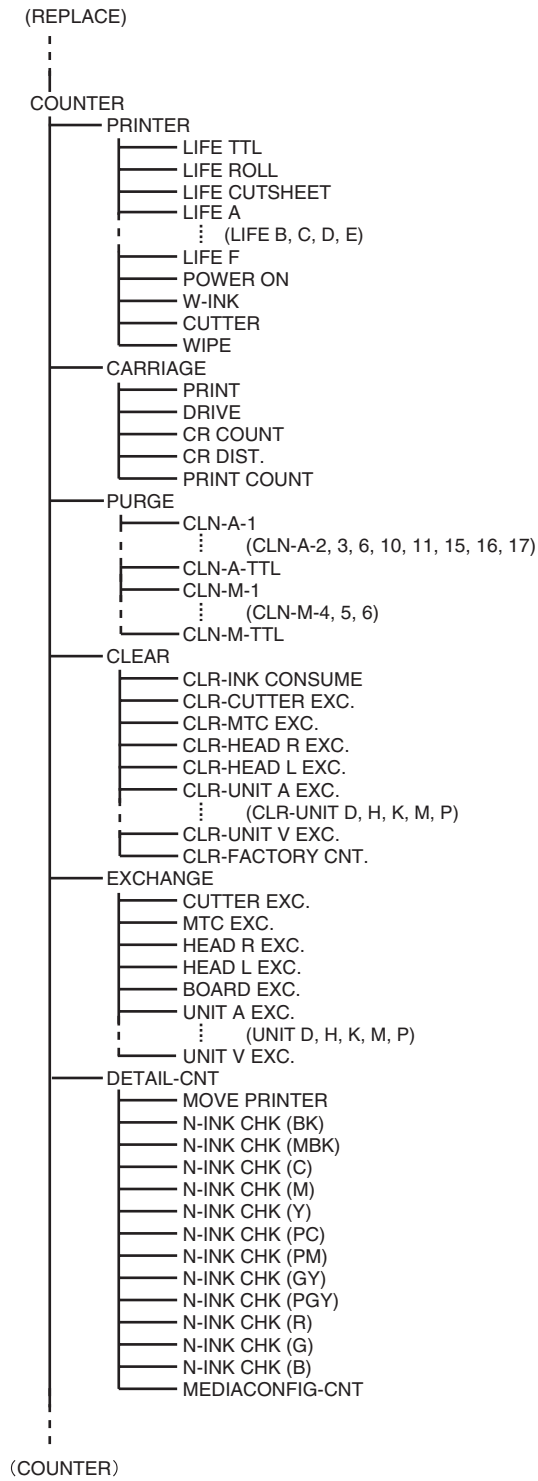

F-7-3

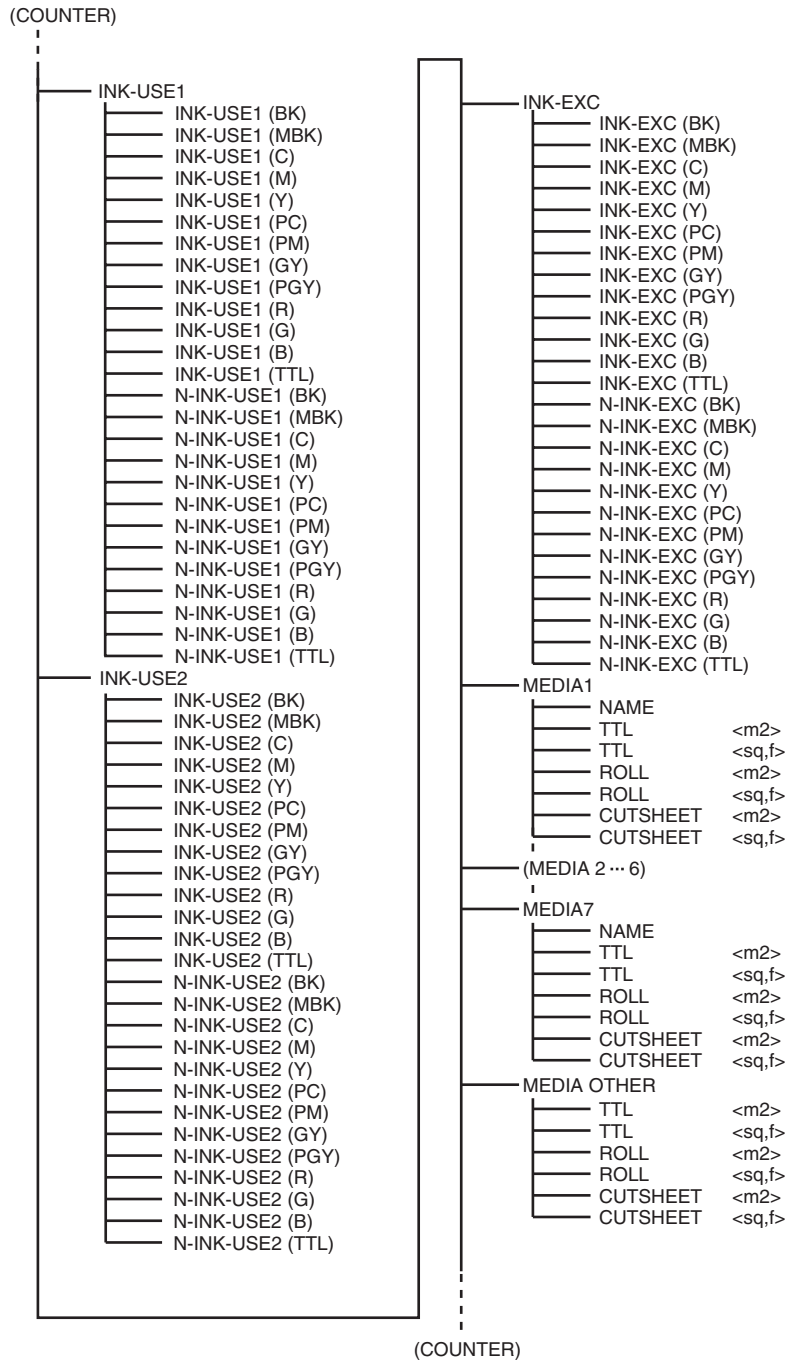

F-7-4

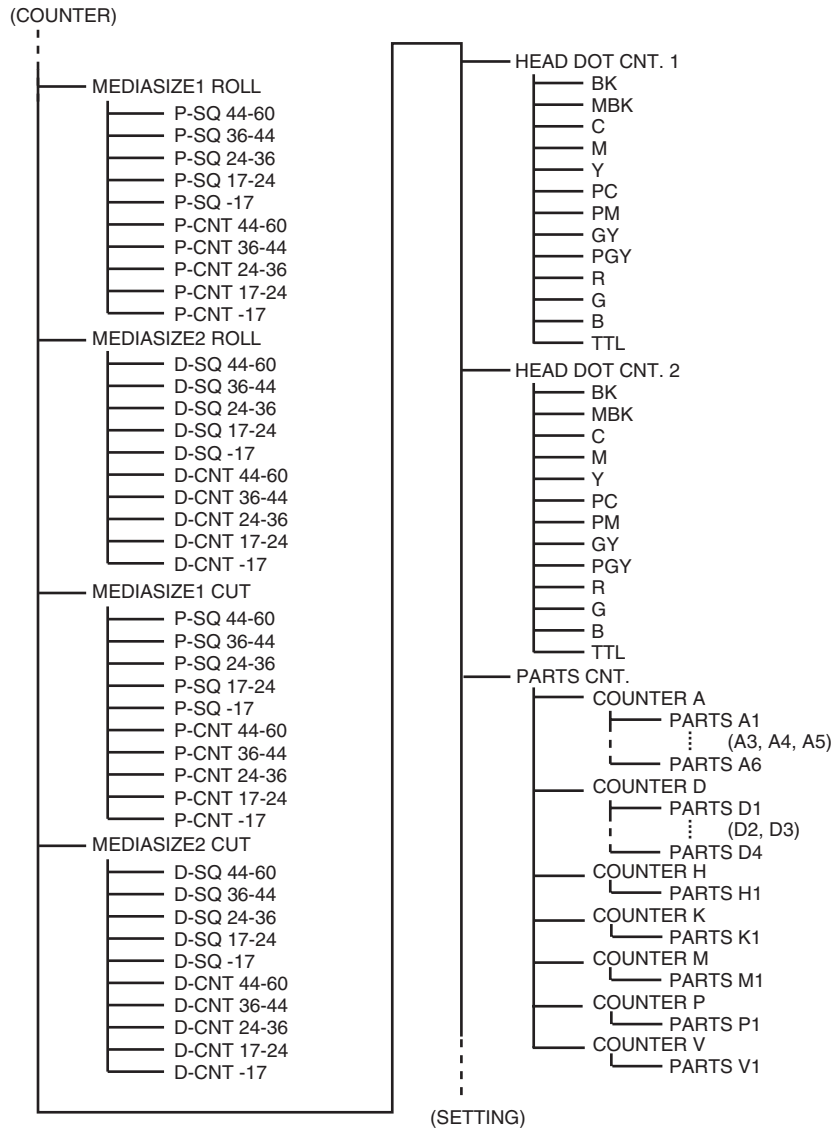

F-7-5

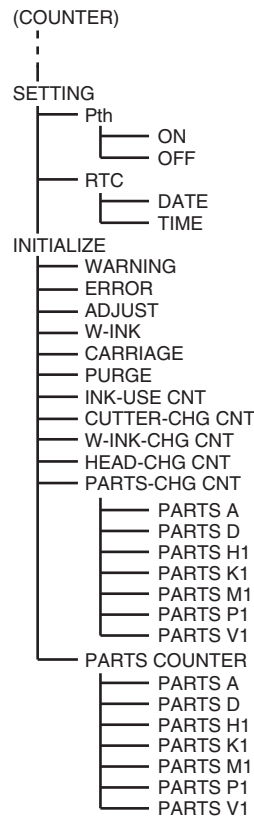

F-7-6

7.1.3 Details for Service mode

This section provides details of the Service mode menus.

a) DISPLAY

Displays and prints the printer information.

1) PRINF INF

Prints adjustment values in the User menu, [DISPLAY] and [COUNTER] parameters on A4-size or larger paper. When a roll media is used, the layout is optimized according to the media width.

2) SYSTEM

Displays the printer information shown below.

T-7-1

Display	Description	Unit
S/N	Serial number of printer	-
TYPE	Type setting on main controller PCB * iPF8000 is represented by 44.	-
LF TYPE	Feed roller type: 0 or 1	-
TMP	Ambient temperature	degrees C
SIZE LF	Detected size of loaded media (feed direction) 0 is always detected for the roll media.	mm
SIZE LF	Detected size of loaded media (feed direction) 0 is always detected for the roll media.	inch
SIZE CR	Detected size of loaded media (carriage scan direction)	mm
SIZE CR	Detected size of loaded media (carriage scan direction)	inch

3) HEAD

Displays the following EEPROM information of the printhead.

T-7-2

Display	Description
S/N R	Serial number of printhead R
S/N L	Serial number of printhead L
LOT R	Lot number of printhead R
LOT L	Lot number of printhead L

4) INK

Displays the numbers of days passed since installation of the following ink tanks.

T-7-3

Display	Description	Unit
BK	Number of days passed since the BK ink tank was installed	Day(s)
MBK	Number of days passed since the MBK ink tank was installed	Day(s)

Display	Description	Unit
C	Number of days passed since the C ink tank was installed	Day(s)
M	Number of days passed since the M ink tank was installed	Day(s)
Y	Number of days passed since the Y ink tank was installed	Day(s)
PC	Number of days passed since the PC ink tank was installed	Day(s)
PM	Number of days passed since the PM ink tank was installed	Day(s)
GY	Number of days passed since the GY ink tank was installed	Day(s)
PGY	Number of days passed since the PGY ink tank was installed	Day(s)
R	Number of days passed since the R ink tank was installed	Day(s)
G	Number of days passed since the G ink tank was installed	Day(s)
B	Number of days passed since the B ink tank was installed	Day(s)

5) WARNING

Displays the warning history (up to 20 events). The newest event has the smallest history number.

6) ERROR

Displays the error history (up to 20 events). The newest event has the smallest history number.

7) INK CHECK

Displays the history of execution of turning off the remaining ink level detection (by using the refilled ink tank) in the order of Y, PC, C, PGY, GY, MBK, PM, M, BK, R, G, and B.

0: No execution

1: Executed at least once

b) ADJUST

Performs adjustments and prints the adjustment and check patterns necessary for adjusting the printer parts.

1) PRINT PATTERN

T-7-4

Display	Description
NOZZLE 1	Prints the nozzle check pattern by single direction/ single pass without using the non-discharging back up. It is used to check for the non-discharging nozzles. - Media size: A4 - Media type: any
OPTICAL AXIS	Prints the pattern and adjusts the optical axis of the multi sensor. For details, refer to "Disassembly/Reassembly" > "Adjustment and Setup Items" > "Action to take after replacing the carriage unit or multi sensor". - Media type: photo glossy paper
LF TUNING	Prints the patterns for adjusting the feed roller eccentricity. For details, refer to "Disassembly/Reassembly" > "Adjustment and Setup Items" > "Action to take after replacing the feed roller HP sensor, feed roller encoder, or the feed roller". - Media size: 44 inches

2) HEAD ADJ.

Set or initialize the registration adjustment values of each printheads.

T-7-5

Display			Description
AUTO HEAD ADJ	ROUGH		Prints the pattern for auto head adjustment (rough adjustment).
MANUAL HEAD ADJ	DETAIL		Prints the detail patterns for the manual head adjustment. After printing, the mode will change to [ADJ. SETTING]. Check the printed patterns and input the set values.
	BASIC		Prints the basic patterns for the manual head adjustment. After printing, the mode will change to [ADJ. SETTING]. Check the printed patterns and input the set values.
ADJ. SETTING	A to F	A-1 to F-1	This mode is to input the registration adjustment values. It is possible to return the values to the former one by printing the status print before changing the value.
	SAVE SETTINGS		Save the registration adjustment values that has been input.
RESET SETTINGS			Initialize the registration adjustment values (to 0).

3) NOZZLE CHK POS.

This mode for adjusting the optical axis of the head management sensor. For details, refer to "Disassembly/Reassembly" > "Adjustment and Setup Items" > "Action to take after replacing the head management sensor".

4) GAP CLIB.

This mode measures the gap between the printhead and media by multi sensor and corrects the calibration value.

5) CHANGE LF TYPE

This mode is for changing the feed roller type.

0: Old type feed roller

1: New type feed roller

c) REPLACE

1) CUTTER

This mode is for replacing the cutter unit.

(It can be also done from the user menu.)

d) COUNTER

Displays the life (operation frequency and time) of each unit, print counts for each media type, and else.

The count values can be printed from [PRINT INF].

1) PRINTER: Counters related to product life

T-7-6

Display	Description	Unit
LIFE TTL	Cumulative number of printed media (equivalent of A4)	sheets
LIFE ROLL	Cumulative number of printed roll media (equivalent of A4)	sheets
LIFE CUTSHEET	Cumulative number of printed cut sheets (equivalent to A4)	sheets
LIFE A-F	Cumulative number of printed media for environments A to F	sheets
POWER ON	Cumulative power-on time (excluding the sleep time)	Hours
W-INK	Remaining capacity of the maintenance cartridge	%
CUTTER	Number of cutting operations (count as 1 by moving back and forth)	Times
WIPE	Number of wiping operations	Times

2) CARRIAGE: Counters related to carriage unit

T-7-7

Display	Description	Unit
PRINT	Cumulative printing time	Hours
DRIVE	Cumulative carriage moving time	Hours
CR COUNT	Cumulative carriage scan count (count as 1 by moving back and forth)	Times
CR DIST.	Cumulative carriage scan distance (count as 1 by moving 210mm)	Times
PRINT COUNT	Cumulative print end count (count as 1 by capping)	Times

3) PURGE: Counters related to purge unit

T-7-8

Display	Description	Unit
CLN-A-1	Cumulative number of automatic cleaning 1 (normal suction) operations	Times
CLN-A-2	Cumulative number of automatic cleaning 2 (ink level adjusting) operations	Times
CLN-A-3	Cumulative number of automatic cleaning 3 (initial filling) operations	Times
CLN-A-6	Cumulative number of automatic cleaning 6 (strong normal suction) operations	Times
CLN-A-10	Cumulative number of automatic cleaning 10 (ink filling after secondary transportation) operations	Times
CLN-A-11	Cumulative number of automatic cleaning 11 (ink filling after head replacement) operations	Times
CLN-A-15	Cumulative number of automatic cleaning 15 (dot count small suction) operations	Times
CLN-A-16	Cumulative number of automatic cleaning 16 (sedimented ink agitation) operations	Times
CLN-A-17	Cumulative number of automatic cleaning 17 (small suction) operations	Times
CLN-A-TTL	Total number of automatic cleaning operations	Times
CLN-M-1	Cumulative number of manual cleaning 1 (normal suction) operations	Times
CLN-M-4	Cumulative number of manual cleaning 4 (ink draining from head after head replacement) operations	Times
CLN-M-5	Cumulative number of manual cleaning 5 (ink draining from head and tube before transportation) operations	Times
CLN-M-6	Cumulative number of manual cleaning 6 (normal strong suction) operations	Times
CLN-M-TTL	Total number of manual cleaning operations	Times

4) CLEAR: Counters related to counter initialization

T-7-9

Display	Description	Unit
CLR-INK CONSUME	Cumulative count of ink section consumption amount clearing	Times
CLR-CUTTER EXC.	Cumulative count of cutter replacement count clearing	Times
CLR-MTC EXC.	Cumulative count of maintenance cartridge replacement count clearing	Times
CLR-HEAD L EXC.	Cumulative count of head L replacement count clearing	Times
CLR-HEAD R EXC.	Cumulative count of head R replacement count clearing	Times
CLR-UNIT A EXC.	Cumulative count of unit A(waste ink system) replacement count clearing	Times
CLR-UNIT D EXC.	Cumulative count of unit D(carriage unit) replacement count clearing	Times
CLR-UNIT H EXC.	Cumulative count of unit H(purge) replacement count clearing	Times
CKR-UNIT K EXC.	Cumulative count of unit K(head management sensor) replacement count clearing	Times
CLR-UNIT P EXC.	Cumulative count of unit P(feed motor) replacement count clearing	Times
CLR-UNIT V EXC.	Cumulative count of unit V(mist fan unit) replacement count clearing	Times
CLR-FACTORY CNT.	For factory	Times

5) EXCHANGE: Counters related to parts replacement

T-7-10

Display	Description	Unit
CUTTER EXC.	Cutter replacement count (Count of executing cutter replacement mode)	Times
MTC EXC.	Maintenance cartridge replacement count	Times
HEAD R EXC.	Head R replacement count	Times
HEAD L EXC.	Head L replacement count	Times
BOARD EXC.(M/B)	Main controller PCB replacement count	Times
UNIT A EXC.	Unit A(waste ink system) replacement count (Count of executing [INITIALIZE] > [PARTS COUNTER] > [PARTS A])	Times
UNIT D EXC.	Unit D(carriage unit) replacement count (Count of executing [INITIALIZE] > [PARTS COUNTER] > [PARTS D])	Times

Display	Description	Unit
UNIT H EXC.	Unit H(purge unit) replacement count (Count of executing [INITIALIZE] > [PARTS COUNTER] > [PARTS H])	Times
UNIT K EXC.	Unit K(head management sensor) replacement count (Count of executing [INITIALIZE] > [PARTS COUNTER] > [PARTS K])	Times
UNIT M EXC.	Unit M(carriage motor) replacement count (Count of executing [INITIALIZE] > [PARTS COUNTER] > [PARTS M])	Times
UNIT P EXC.	Unit P(feed unit) replacement count (Count of executing [INITIALIZE] > [PARTS COUNTER] > [PARTS P])	Times
UNIT V EXC.	Unit V(mist fan unit) replacement count (Count of executing [INITIALIZE] > [PARTS COUNTER] > [PARTS V])	Times

6) DETAIL-CNT: Other counters

T-7-11

Display	Description	Unit
MOVE PRINTER	Count of [Move Printer] operations	Times
N-INKCHK(XX)	XX: Ink color Count of turning off the ink remaining level detection for each color	Times
MEDIACONFIG-CNT	Count of media registered by media editor	Times

7) INK-USE1: Counters related to ink consumption

T-7-12

Display	Description	Unit
INK-USE1(XX)	XX: Ink color Cumulative consumption amount of generic ink	ml
INK-USE1(TTL)	Total amount of the cumulative consumption of generic ink	ml
N-INK-USE1(XX)	XX: Ink color Cumulative consumption amount of refilled ink	ml
N-INK-USE1(TTL)	Total amount of the cumulative consumption of refilled ink	ml

8) INK-USE2: Counters related to ink consumption

T-7-13

Display	Description	Unit
INK-USE2(XX)	XX: Ink color Consumption amount of generic ink of the currently installed ink tank.	ml
INK-USE2(TTL)	Total consumption amount of generic ink of the currently installed ink tanks	ml
N-INK-USE2(XX)	XX: Ink color Consumption amount of refilled ink of the currently installed ink tank	ml
N-INK-USE2(TTL)	Total consumption amount of refilled ink of the currently installed ink tanks	ml

9) INK-EXC: Counters related to ink tank replacement

T-7-14

Display	Description	Unit
INK-EXC(XX)	XX: Ink color Cumulative count of generic ink tank replacement	ml
INK-EXC(TTL)	Total amount of the cumulative count of generic ink tank replacement	ml
N-INK-EXC(XX)	XX: Ink color Cumulative count of refilled ink tank replacement	ml
N-INK-EXC(TTL)	Total amount of the cumulative count of refilled ink tank replacement	ml

10) MEDIA x (x: 1 to 7): Counters related to media

One to seven media types are displayed individually in order with large cumulative print area.

T-7-15

Display	Description	Unit
NAME	Media type	-
TTL	Total amount of cumulative print area of roll media and cut sheet (metric)	m2
TTL	Total amount of cumulative print area of roll media and cut sheet (inch)	Sq.f
ROLL	Cumulative print area of roll media (metric)	m2
ROLL	Cumulative print area of roll media (inch)	Sq.f
CUT SHEET	Cumulative print area of cut sheet (metric)	m2
CUT SHEET	Cumulative print area of cut sheet (inch)	Sq.f

11) MEDIA OTHER: Counters related to media

Displays the total amount of cumulative print area of the other media type than the above-mentioned

T-7-16

Display	Description	Unit
TTL	Total amount of cumulative print area of roll media and cut sheet (metric)	m2
TTL	Total amount of cumulative print area of roll media and cut sheet (inch)	Sq.f
ROLL	Cumulative print area of roll media (metric)	m2
ROLL	Cumulative print area of roll media (inch)	Sq.f
CUT SHEET	Cumulative print area of cut sheet (metric)	m2

Display	Description	Unit
CUT SHEET	Cumulative print area of cut sheet (inch)	Sq.f

12) MEDIASIZE1 ROLL: Counters related to roll media printing

T-7-17

Display	Description	Unit
P-SQ 44-60	Cumulative print area of paper equal to or larger than 44 inches but less than 60 inches (physical size)	m2/Sq.f
P-SQ 36-44	Cumulative print area of paper equal to or larger than 36 inches but less than 44 inches (physical size)	m2/Sq.f
P-SQ 24-36	Cumulative print area of paper equal to or larger than 24 inches but less than 36 inches (physical size)	m2/Sq.f
P-SQ 17-24	Cumulative print area of paper equal to or larger than 17 inches but less than 24 inches (physical size)	m2/Sq.f
P-SQ -17	Cumulative print area of paper less than 17 inches (physical size)	m2/Sq.f
P-CNT 44-60	Cumulative number of sheets of A4-equivalent paper equal to or larger than 44 inches but less than 60 inches (physical size)	sheets
P-CNT 36-44	Cumulative number of sheets of A4-equivalent paper equal to or larger than 36 inches but less than 44 inches (physical size)	sheets
P-CNT 24-36	Cumulative number of sheets of A4-equivalent paper equal to or larger than 24 inches but less than 36 inches (physical size)	sheets
P-CNT 17-24	Cumulative number of sheets of A4-equivalent paper equal to or larger than 17 inches but less than 24 inches (physical size)	sheets
P-CNT -17	Cumulative number of sheets of A4-equivalent paper less than 17 inches (physical size)	sheets

13) MEDIASIZE2 ROLL: Counters related to roll media printing

T-7-18

Display	Description	Unit
D-SQ 44-60	Cumulative print area of paper equal to or larger than 44 inches but less than 60 inches (data size)	m2/Sq.f
D-SQ 36-44	Cumulative print area of paper equal to or larger than 36 inches but less than 44 inches (data size)	m2/Sq.f
D-SQ 24-36	Cumulative print area of paper equal to or larger than 24 inches but less than 36 inches (data size)	m2/Sq.f
D-SQ 17-24	Cumulative print area of paper equal to or larger than 17 inches but less than 24 inches (data size)	m2/Sq.f
D-SQ -17	Cumulative print area of paper less than 17 inches (data size)	m2/Sq.f
D-CNT 44-60	Cumulative number of sheets of A4-equivalent paper equal to or larger than 44 inches but less than 60 inches (data size)	sheets
D-CNT 36-44	Cumulative number of sheets of A4-equivalent paper equal to or larger than 36 inches but less than 44 inches (data size)	sheets
D-CNT 24-36	Cumulative number of sheets of A4-equivalent paper equal to or larger than 24 inches but less than 36 inches (data size)	sheets
D-CNT 17-24	Cumulative number of sheets of A4-equivalent paper equal to or larger than 17 inches but less than 24 inches (data size)	sheets
D-CNT -17	Cumulative number of sheets of A4-equivalent paper less than 17 inches (data size)	sheets

14) MEDIASIZE1 CUT: Counters related to cut sheet printing

T-7-19

Display	Description	Unit
P-SQ 44-60	Cumulative print area of paper equal to or larger than 44 inches but less than 60 inches (physical size)	m2/Sq.f
P-SQ 36-44	Cumulative print area of paper equal to or larger than 36 inches but less than 44 inches (physical size)	m2/Sq.f
P-SQ 24-36	Cumulative print area of paper equal to or larger than 24 inches but less than 36 inches (physical size)	m2/Sq.f
P-SQ 17-24	Cumulative print area of paper equal to or larger than 17 inches but less than 24 inches (physical size)	m2/Sq.f
P-SQ -17	Cumulative print area of paper less than 17 inches (physical size)	m2/Sq.f
P-CNT 44-60	Cumulative number of sheets of A4-equivalent paper equal to or larger than 44 inches but less than 60 inches (physical size)	sheets
P-CNT 36-44	Cumulative number of sheets of A4-equivalent paper equal to or larger than 36 inches but less than 44 inches (physical size)	sheets
P-CNT 24-36	Cumulative number of sheets of A4-equivalent paper equal to or larger than 24 inches but less than 36 inches (physical size)	sheets
P-CNT 17-24	Cumulative number of sheets of A4-equivalent paper equal to or larger than 17 inches but less than 24 inches (physical size)	sheets
P-CNT -17	Cumulative number of sheets of A4-equivalent paper less than 17 inches (physical size)	sheets

15) MEDIASIZE2 CUT: Counters related to cut sheet printing

T-7-20

Display	Description	Unit
D-SQ 44-60	Cumulative print area of paper equal to or larger than 44 inches but less than 60 inches (data size)	m2/Sq.f
D-SQ 36-44	Cumulative print area of paper equal to or larger than 36 inches but less than 44 inches (data size)	m2/Sq.f
D-SQ 24-36	Cumulative print area of paper equal to or larger than 24 inches but less than 36 inches (data size)	m2/Sq.f
D-SQ 17-24	Cumulative print area of paper equal to or larger than 17 inches but less than 24 inches (data size)	m2/Sq.f
D-SQ -17	Cumulative print area of paper less than 17 inches (data size)	m2/Sq.f
D-CNT 44-60	Cumulative number of sheets of A4-equivalent paper equal to or larger than 44 inches but less than 60 inches (data size)	sheets
D-CNT 36-44	Cumulative number of sheets of A4-equivalent paper equal to or larger than 36 inches but less than 44 inches (data size)	sheets
D-CNT 24-36	Cumulative number of sheets of A4-equivalent paper equal to or larger than 24 inches but less than 36 inches (data size)	sheets
D-CNT 17-24	Cumulative number of sheets of A4-equivalent paper equal to or larger than 17 inches but less than 24 inches (data size)	sheets
D-CNT -17	Cumulative number of sheets of A4-equivalent paper less than 17 inches (data size)	sheets

16) HEAD DOT CNT.1: Counter related to dot count

T-7-21

Display	Description	Unit
XX	XX: Ink color Dot counts of each colors of the currently installed printhead	(x 1,000,000) dots
TTL	Total dot counts of each colors of the currently installed printhead	(x 1,000,000) dots

17) HEAD DOT CNT.2: Counter related to dot count

T-7-22

Display	Description	Unit
XX	XX: Ink color Cumulative dot counts of each colors	(x 1,000,000) dots
TTL	Total cumulative dot counts of each colors	(x 1,000,000) dots

18) PARTS CNT. : Counter related to consumable parts

T-7-23

Display	Description	Unit
COUNTER x	x: A to V (For detail, refer to "Maintenance and Inspection" > "Consumable Parts") Display the status and the days passed since the counter resetting. - Status OK: Use rate (until part replacement) of all consumable parts included in each unit are below 90%. W1: Use rate (until part replacement) of either of the consumable parts included in each unit has reached 90% or more. W2: Use rate (until part replacement) of either of the consumable parts included in each unit has reached 100%, but no need to stop the printer. E : Use rate (until part replacement) of either of the consumable parts included in each unit has reached 100%, and the printer needs to be stopped.	Day(s)
PARTS yy	1: yy: A to V1 (For detail, refer to "Maintenance and Inspection" > "Consumable Parts") Counter of the consumable part (current)	
	2: Life of the consumable part	
	3: Use rate until part replacement	%
	4: Counter of the consumable part (accumulate)	

e) SETTING

Make various settings.

1) Pth

Turn on or off the head pulse rank control function.

Default: OFF

2) RTC

Set RTC (real time clock) after replacing the lithium battery on the main controller PCB.

T-7-24

Display	Description
DATE	yyyy/mm/dd Set date
TIME	hh:mm Set time

f) INITIALIZE

Clear the [DISPLAY] histories, [ADJUST] settings, [COUNTER] values, and other parameters.

T-7-25

Display	Description
WARNING	Initialize the history of WARNING. (All displayed contents of [DISPLAY] > [WARNING] will be initialized.)
ERROR	Initialize the history of ERROR. (All displayed contents of [DISPLAY] > [ERROR] will be initialized.)
ADJUST	Initialize the value of band adjustment (by user) and head adjustment. The automatically adjusted value will not be initialized.
W-INK	Initialize the remaining capacity (%) of the maintenance cartridge. (Clear [COUNTER] > [PRINTER] > [W-INK])
CARRIAGE	Initialize the cumulative time of carriage driving. (Clear [COUNTER] > [CARRIAGE] > [DRIVE])
PURGE	Initialize the counter related to purge unit. (Clear [COUNTER] > [PURGE])
INK-USE CNT	Initialize the consumption amount of ink. (Clear [COUNTER] > [INK-USE2], and count up [COUNTER] > [CLEAR] > [CLR-INK CONSUME])
CUTTER-CHG CNT	Initialize the cutter unit replacement frequency. (Clear [COUNTER] > [EXCHANGE] > [CUTTER EXC.], and count up [COUNTER] > [CLEAR] > [CLR-CUTTER EXC.]
W-INK-CHG CNT	Initialize the maintenance cartridge replacement frequency. (Clear [COUNTER] > [EXCHANGE] > [MTC EXC.], and count up [COUNTER] > [CLEAR] > [CLR-MTC EXC.]
HEAD-CHG R CNT	Initialize the printhead R replacement frequency. (Clear [COUNTER] > [EXCHANGE] > [HEAD R EXC.], and count up [COUNTER] > [CLEAR] > [CLR-HEAD R EXC.]
HEAD-CHG L CNT	Initialize the printhead L replacement frequency. (Clear [COUNTER] > [EXCHANGE] > [HEAD L EXC.], and count up [COUNTER] > [CLEAR] > [CLR-HEAD L EXC.]
PARTS-CHG CNT	PARTS xx xx: A to V1 (For details, refer to "Maintenance and Inspection" > "Consumable Parts") Initialize the consumable part replacement frequency. (Clear [COUNTER] > [EXCHANGE] > [UNIT x EXC], and count up [COUNTER] > [CLEAR] > [CLR-UNIT x EXC.]

Display		Description
PARTS COUNTER	PARTS xx	xx: A to V1 (For details, refer to "Maintenance and Inspection" > "Consumable Parts") Initialize the counter amount of the consumable parts. (Clear [COUNTER] > [PARTS CNT.] > [COUNTER x]) * After replacing the consumable part, be sure to execute this menu.

7.2 Special Mode

7.2.1 Special Modes for Servicing

This printer supports the following special modes in addition to the service mode:

- **PCB replacement mode**
- **Download mode**

1. PCB replacement mode

This mode is used when replacing the main controller PCB or maintenance cartridge relay PCB.

By executing this mode,

- Backup data of the settings and counter values stored in the maintenance cartridge relay PCB are moved to the new main controller PCB.
- The data such as the settings and counter values are copied to the maintenance cartridge relay PCB.

a) Entering the PCB replacement mode

Follow the same procedure as that for entering the service mode.

(With the "Paper Source" button and "Information" button pressed down, turn on the printer.)

When the printer starts up, compare the serial number memorized in the main PCB's EEPROM with that memorized in the maintenance cartridge relay PCB's EEPROM. If they do not match, or no serial number is memorized in either EEPROM, enter the PCB replacement mode.

While you are in the PCB replacement mode, the MESSAGE LED, roll media LED, and ONLINE LED are lit.

b) Procedure

Select "CPU BOARD" or "MC BOARD" using the [◀] and [▶] buttons, and then press the [OK] button to determine it.

- CPU BOARD

Select this after replacing the main controller PCB.

The data in the maintenance cartridge relay PCB is copied to the main controller PCB.

- MC BOARD

Select this before replacing the main controller PCB.

The data in the main PCB is copied to the maintenance cartridge relay PCB.

Use this when the maintenance cartridge relay PCB is a new one.

c) Exiting the PCB replacement mode

Turning off the Power button of the printer allows you to exit the PCB replacement mode.

For details on how to replace the PCB, see "Parts Replacement Procedure" > "Disassembly/Reassembly" > "Points to Note on Disassembly and Reassembly" > "PCBs".

2. Download mode

Use this mode only when updating the firmware without performing initialization.

a) Entering the download mode

1) Turn off the printer.

2) With the "Stop" and "Information" buttons pressed down, turn on the printer.

b) Procedure

When "Download Mode/Send Firmware" is shown on the display, transfer the firmware.

When downloading of the firmware is completed, the printer will be turned off automatically.

Chapter 8 ERROR CODE

Contents

8.1 Outline.....	8-1
8.1.1 Outline.....	8-1
8.2 Warning Table.....	8-1
8.2.1 Warnings.....	8-1
8.3 Error Table.....	8-2
8.3.1 Errors.....	8-2
8.4 Service Call Table.....	8-5
8.4.1 Service call errors.....	8-5

8.1 Outline

8.1.1 Outline

The printer indicates errors using the display and LEDs.

If an error occurs during printing, the printer status is also displayed on the status monitor of the printer driver.

The following three types of errors are displayed on the display:

- Warning

Status where the print operation can be continued without remedying the cause of the problem. This can, however, adversely affect the printing results.

- Error

Status where the print operation is stopped, and the regular operation cannot be recovered until the cause of the problem is remedied.

- Service call error

When a service call error occurs, the error is not cleared and the error indication remains on the operation panel even if the printer is powered off and on again.

(Occurrence of the service call error is indicated again at power-on.)

This measure is taken to prevent user's recovery of the service call error and damages to the printer.

Service call errors can be cleared, however, by starting up the printer in the service mode.

For how to take actions against warnings and errors, refer to "Troubleshooting".

Overview of warnings and error codes

The codes of warnings and errors are shown below according to the system.

T-8-1

Code	Diagnosis
0181xxxx-xxxx	Ink warning
0180xxxx-xxxx	Printhead warning
0184xxxx-xxxx	Maintenance cartridge warning
0134xxxx-xxxx	GARO warning
0303xxxx-xxxx	Cover error
0301xxxx-xxxx 0306xxxx-xxxx 0386xxxx-xxxx	Media error
0313xxxx-xxxx	Sensors, fans, motors error
0380xxxx-xxxx	Printhead error
0381xxxx-xxxx 0383xxxx-xxxx	Ink error
0384xxxx-xxxx	Maintenance cartridge error
0387xxxx-xxxx	Cutter unit error
0389xxxx-xxxx	Media take-up unit error
0390xxxx-xxxx	Firmware error
Exxx-xxxx	Service call error

* "x" stands for a numeric or letter.

8.2 Warning Table

8.2.1 Warnings

The codes correspond to the numbers shown on the DISPLAY in the service mode.

T-8-2

Code	Display message	Status
01810104-1000	Ink Lv1: Chk	BK ink tank is almost empty
01810101-1001	Ink Lv1: Chk	Y ink tank is almost empty
01810102-1002	Ink Lv1: Chk	M ink tank is almost empty
01810103-1003	Ink Lv1: Chk	C ink tank is almost empty
01810112-1004	Ink Lv1: Chk	PM ink tank is almost empty
01810113-1005	Ink Lv1: Chk	PC ink tank is almost empty
01810106-1006	Ink Lv1: Chk	MBK ink tank is almost empty
01810105-1008	Ink Lv1: Chk	GY ink tank is almost empty
01810115-1009	Ink Lv1: Chk	PGY ink tank is almost empty
01810107-100A	Ink Lv1: Chk	R ink tank is almost empty
01810109-100B	Ink Lv1: Chk	B ink tank is almost empty
01810108-100C	Ink Lv1: Chk	G ink tank is almost empty
01841001-281A	Check maint cartridge capacity.	Maintenance cartridge is almost full
01810304-1400	Ink tank is empty. Replace the ink tank.	BK ink tank is empty
01810301-1401	Ink tank is empty. Replace the ink tank.	Y ink tank is empty
01810302-1402	Ink tank is empty. Replace the ink tank.	M ink tank is empty
01810303-1403	Ink tank is empty. Replace the ink tank.	C ink tank is empty
01810312-1404	Ink tank is empty. Replace the ink tank.	PM ink tank is empty
01810313-1405	Ink tank is empty. Replace the ink tank.	PC ink tank is empty
01810306-1406	Ink tank is empty. Replace the ink tank.	MBK ink tank is empty
01810305-1408	Ink tank is empty. Replace the ink tank.	GY ink tank is empty
01810315-1409	Ink tank is empty. Replace the ink tank.	PGY ink tank is empty
01810307-140A	Ink tank is empty. Replace the ink tank.	R ink tank is empty

Code	Display message	Status
01810309-140B	Ink tank is empty. Replace the ink tank.	B ink tank is empty
01810308-140C	Ink tank is empty. Replace the ink tank.	G ink tank is empty
01810104-1410	No ink tank loaded. Check ink tank.	BK ink tank is not loaded (when printing)
01810101-1411	No ink tank loaded. Check ink tank.	Y ink tank is not loaded (when printing)
01810102-1412	No ink tank loaded. Check ink tank.	M ink tank is not loaded (when printing)
01810103-1413	No ink tank loaded. Check ink tank.	C ink tank is not loaded (when printing)
01810112-1414	No ink tank loaded. Check ink tank.	PM ink tank is not loaded (when printing)
01810113-1415	No ink tank loaded. Check ink tank.	PC ink tank is not loaded (when printing)
01810106-1416	No ink tank loaded. Check ink tank.	MBK ink tank is not loaded (when printing)
01810105-1418	No ink tank loaded. Check ink tank.	GY ink tank is not loaded (when printing)
01810115-1419	No ink tank loaded. Check ink tank.	PGY ink tank is not loaded (when printing)
01810107-141A	No ink tank loaded. Check ink tank.	R ink tank is not loaded (when printing)
01810109-141B	No ink tank loaded. Check ink tank.	B ink tank is not loaded (when printing)
01810108-141C	No ink tank loaded. Check ink tank.	G ink tank is not loaded (when printing)
01031101-	Close Ink Tank Cover	Ink tank cover is opened (when printing)
01341221-1030	GARO W1221	Unsupported command in GARO image mode
01341222-1031	GARO W1222	Invalid number of parameters in GARO image mode (no parameter)
01341223-1032	GARO W1223	Required item was omitted in GARO image mode
01341225-1034	GARO W1225	Other warning in GARO image mode
01341231-1035	GARO W1231	Unsupported command in GARO setting mode
01341232-1036	GARO W1232	Invalid number of parameters in GARO setting mode
01341233-1037	GARO W1233	Required item was omitted in GARO setting mode
01341234-1038	GARO W1234	Data out of range in GARO image mode
01341235-1039	GARO W1235	Other warning in GARO setting mode
00000000-100F	Feed Limit..	Force feed limit
01800500-1012	Check printed document.	Printhead R not discharging
01800500-1013		Printhead L not discharging
01060000-	Paper Size Wrong	Media size mismatch
01061000-1021	Paper Type Wrong	Media type mismatch
	Prepare for parts replacement. Call for service.	Parts counter warning level 1 (W1)
	Parts replacement time has passed. Call for service.	Parts counter warning level 2 (W2)

8.3 Error Table

8.3.1 Errors

The codes correspond to the numbers shown on the DISPLAY in the service mode.

T-8-3

Code	Status
03010000-200A	Media width detection error
03010000-200B	Media set position error
03010000-200C	Media leading edge not detected
03010000-200D	Cut sheet end cannot be detected
03010000-200E	Media too small
03010000-200F	Media too large
03010000-2016	Media became misaligned during feeding
03010000-2017	Media right edge not detected
03010000-2018	Media left edge not detected
03010000-2820	Head resistration improper adjustment
03010000-2821	LF improper adjustment
03010000-2822	Eccentricity improper adjustment
03010000-2823	Printhead check error
03010000-2824	Optical axis error
03010000-2E18	Media feeding failure
03010000-2E19	Feed error
03010000-2E1A	
03010000-2E1D	
03010000-2E1C	Ejection error
03010000-2E1F	Media is too small to print adjustment pattern
03010000-2E27	Media became misaligned during printing
03010000-2F33	Transparent media was loaded and cannot adjust
03016000-2010	Media skewed
03130000-2E21	IEEE error
03030000-2F29	Feed motor time out
03031000-2E0F	Upper cover open error
03031000-2E11	Carriage cover open error
03031000-2E12	Release lever error

Code	Status
03031000-2F38	Upper cover abnormally open
03031000-2F39	Carriage cover abnormally open
03031101-2E10	Ink tank cover error
03060000-2E14	Media size mismatch
03060000-2E16	Media type mismatch
03060000-2E20	Media type mismatch when printing adjusting patterns
03060100-2E02	No cut sheet loaded when cut sheet is required
03060A00-2E08	Media width mismatch
03060A00-2E00	Roll media was not loaded even though the received data indicated roll media.
03060A00-2E1B	End of roll media
03061000-2E15	Media type mismatch
03130031-260E	Gap detection error
03130031-260F	Gap reference surface error (not generated in the user mode.)
03130031-2618	VH voltage error
03130031-2F11	Carriage unit error
03130031-2F12	Feed unit error
03130031-2F13	A/D converter outside trigger output stop
03130031-2F14	ASIC register writing error
03130031-2F16	Mist fan error
03130031-2F17	Platen fan error
03130031-2F1F	Purge motor HP error
03130031-2F20	Purge motor error
03130031-2F22	Pump movement timeout
03130031-2F23	Pump cannot operate
03130031-2F25	Unable to detect CR motor HP
03130031-2F26	Carriage motor driving error
03130031-2F27	Carriage motor timeout
03130031-2F2A	Feed roller HP sensor error
03130031-2F2B	Feed motor driving error
03130031-2F2E	Roll media drive time out
03130031-2F32	Multi sensor faulty
03130031-2F3A	Valve motor error
03130031-2F28	Lift motor time out
03130031-2F36	EEPROM error
03130031-2F37	linear scale error
03800101-2800	Printhead R not installed
03800102-2808	Printhead L not installed
03800201-2802	Improper printhead R installed
03800201-2804	Printhead R installed to left side
03800201-2812	Printhead R version mismatch
03800202-2807	Printhead L installed to right side
03800202-280A	Improper printhead L installed
03800202-2813	Printhead L version mismatch
03800301-2801	Printhead R DI correction failure
03800302-2809	Printhead L DI correction failure
03800401-2803	Printhead R EEPROM error
03800402-280B	Printhead L EEPROM error
03800500-2F2F	Head management sensor error
03800500-2F30	Head management sensor position adjustment error
03800500-2F31	Head management sensor light-emission level error
03800501-280D	Many non-discharging nozzles on printhead R
03800502-280E	Many non-discharging nozzles on printhead L
03810104-2500	No ink (BK)
03810101-2501	No ink (Y)
03810102-2502	No ink (M)
03810103-2503	No ink (C)
03810112-2504	No ink (PM)
03810113-2505	No ink (PC)
03810106-2506	No ink (MBK)
03810105-2508	No ink (GY)
03810115-2509	No ink (PGY)
03810107-250A	No ink (R)
03810109-250B	No ink (B)
03810108-250C	No ink (G)
03810204-2580	Remaining ink low (BK)
03810201-2581	Remaining ink low (Y)

Code	Status
03810202-2582	Remaining ink low (M)
03810203-2583	Remaining ink low (C)
03810212-2584	Remaining ink low (PM)
03810213-2585	Remaining ink low (PC)
03810206-2586	Remaining ink low (MBK)
03810205-2588	Remaining ink low (GY)
03810215-2589	Remaining ink low (PGY)
03810207-258A	Remaining ink low (R)
03810209-258B	Remaining ink low (B)
03810208-258C	Remaining ink low (G)
03810204-2590	Remaining ink low (BK)
03810201-2591	Remaining ink low (Y)
03810202-2592	Remaining ink low (M)
03810203-2593	Remaining ink low (C)
03810212-2594	Remaining ink low (PM)
03810213-2595	Remaining ink low (PC)
03810206-2596	Remaining ink low (MBK)
03810205-2598	Remaining ink low (GY)
03810215-2599	Remaining ink low (PGY)
03810207-259A	Remaining ink low (R)
03810209-259B	Remaining ink low (B)
03810208-259C	Remaining ink low (G)
03830104-2510	Ink tank status not detected (BK)
03830101-2511	Ink tank status not detected (Y)
03830102-2512	Ink tank status not detected (M)
03830103-2513	Ink tank status not detected (C)
03830112-2514	Ink tank status not detected (PM)
03830113-2515	Ink tank status not detected (PC)
03830106-2516	Ink tank status not detected (MBK)
03830105-2518	Ink tank status not detected (GY)
03830115-2519	Ink tank status not detected (PGY)
03830107-251A	Ink tank status not detected (R)
03830109-251B	Ink tank status not detected (B)
03830108-251C	Ink tank status not detected (G)
03830104-2520	Ink tank not installed (BK)
03830101-2521	Ink tank not installed (Y)
03830102-2522	Ink tank not installed (M)
03830103-2523	Ink tank not installed (C)
03830112-2524	Ink tank not installed (PM)
03830113-2525	Ink tank not installed (PC)
03830106-2526	Ink tank not installed (MBK)
03830105-2528	Ink tank not installed (GY)
03830115-2529	Ink tank not installed (PGY)
03830107-252A	Ink tank not installed (R)
03830109-252B	Ink tank not installed (B)
03830108-252C	Ink tank not installed (G)
03830204-2540	Ink tank ID error (BK)
03830201-2541	Ink tank ID error (Y)
03830202-2542	Ink tank ID error (M)
03830203-2543	Ink tank ID error (C)
03830212-2544	Ink tank ID error (PM)
03830213-2545	Ink tank ID error (PC)
03830206-2546	Ink tank ID error (MBK)
03830205-2548	Ink tank ID error (GY)
03830215-2549	Ink tank ID error (PGY)
03830207-254A	Ink tank ID error (R)
03830209-254B	Ink tank ID error (B)
03830208-254C	Ink tank ID error (G)
03830304-2560	Ink tank EEPROM error (BK)
03830301-2561	Ink tank EEPROM error (Y)
03830302-2562	Ink tank EEPROM error (M)
03830303-2563	Ink tank EEPROM error (C)
03830312-2564	Ink tank EEPROM error (PM)
03830313-2565	Ink tank EEPROM error (PC)
03830306-2566	Ink tank EEPROM error (MBK)
03830305-2568	Ink tank EEPROM error (GY)

Code	Status
03830315-2569	Ink tank EEPROM error (PGY)
03830307-256A	Ink tank EEPROM error (R)
03830309-256B	Ink tank EEPROM error (B)
03830308-256C	Ink tank EEPROM error (G)
03830304-2570	Remaining ink low (BK)
03830301-2571	Remaining ink low (Y)
03830302-2572	Remaining ink low (M)
03830303-2573	Remaining ink low (C)
03830312-2574	Remaining ink low (PM)
03830313-2575	Remaining ink low (PC)
03830306-2576	Remaining ink low (MBK)
03830305-2578	Remaining ink low (GY)
03830315-2579	Remaining ink low (PGY)
03830307-257A	Remaining ink low (R)
03830309-257B	Remaining ink low (B)
03830308-257C	Remaining ink low (G)
03841001-2819	Maintenance cartridge tank full
03841101-2818	Maintenance cartridge not installed
03841201-2816	Maintenance cartridge EEPROM error
03841201-2817	Maintenance cartridge ID error
03841001-281B	Empty capacity of the maintenance cartridge when cleaning it various is insufficient.
03860002-2E0A	Manually fed cut sheet was already loaded even though received data indicated roll media
03860002-2E0C	When the roll paper was loaded, the data of the cut sheet specification was received.
03861001-2405	Media set position unsuitable for borderless printing
03861001-2406	Received data unsuitable for borderless printing
03862000-2E09	Roll paper running out
03870001-2015	Cutting failure
03890000-2920	Cannot take up media
03890000-2921	Taking up media not stopping
03900001-4042	MIT data transfer failure
03900001-4049	Forwarding ROM data machine kind difference
E194-4034	Sensor calibration error

8.4 Service Call Table

8.4.1 Service call errors

Codes correspond to the numbers shown on the DISPLAY in the service mode.

T-8-4

Code	Description	Display message
E141-4046	Recovery system rotation count full	ERROR Exxx-xxxx Call For Service
E144-4047	Feed system counting error	
E146-4001	Waste ink count full	
E194-404A	No ink ejection counting error	
E161-403E	Abnormally high temperature: printhead R	
E161-403F	Abnormally high temperature: printhead L	
E196-4040	Checksum error	
E196-4041	Flash memory clearing error	
E196-4042	Flash memory write error	
E196-4045	Engine EEPROM write error	
E196-4049	Transfer ROM data type error	
E196-4042	MIT Data transfer error	
E198-401C	RTC error	
E198-401D	RTC low battery error	
E198-401E	RTC clock stopped	
E199-404B	Humidity sensor unplugged	

Oct 3 2006

Canon