

CANON INC.

9-9, Ginza 5-chome, Chuo-ku, Tokyo 104, Japan

CANON U.S.A., INC.

10 Nevada Drive, Lake Success, Long Island, N.Y. 11040, U.S.A.

CANON U.S.A., INC., CHICAGO OFFICE

457 Fullerton Avenue, Elmhurst, Illinois 60126, U.S.A.

CANON OPTICS & BUSINESS MACHINES CO., INC.

3113 Wilshire Blvd., Los Angeles, California 90010, U.S.A.

CANON AMSTERDAM N.V.

Gebouw 70, Schiphol Oost, Holland

CANON LATIN AMERICA, INC.

Apartado 7022, Panama 5, Panama

PUB. IE 1004C

0972B5

PRINTED IN JAPAN





Canon
AUTO ZOOM 814
ELECTRONIC

INSTRUCTIONS

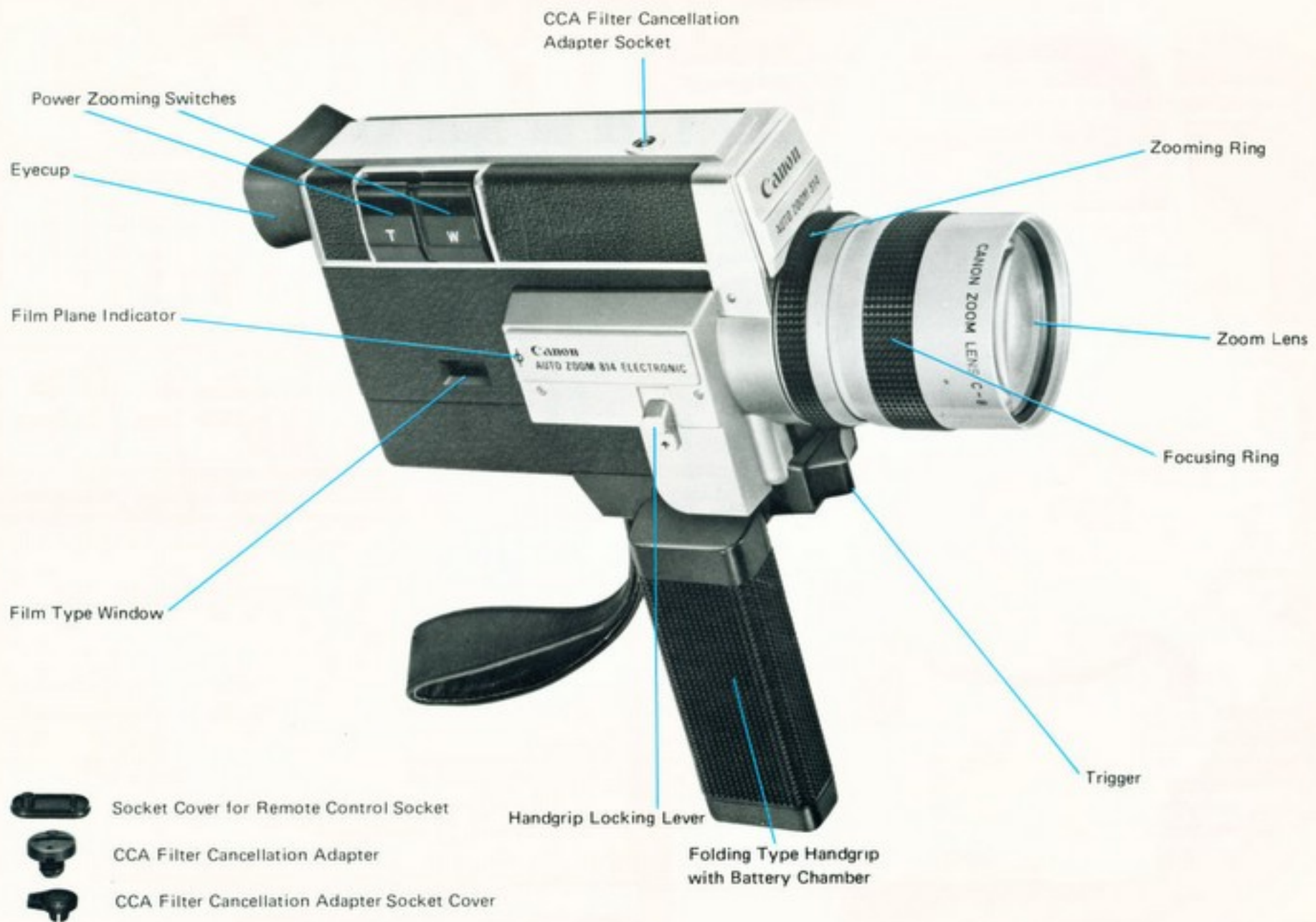
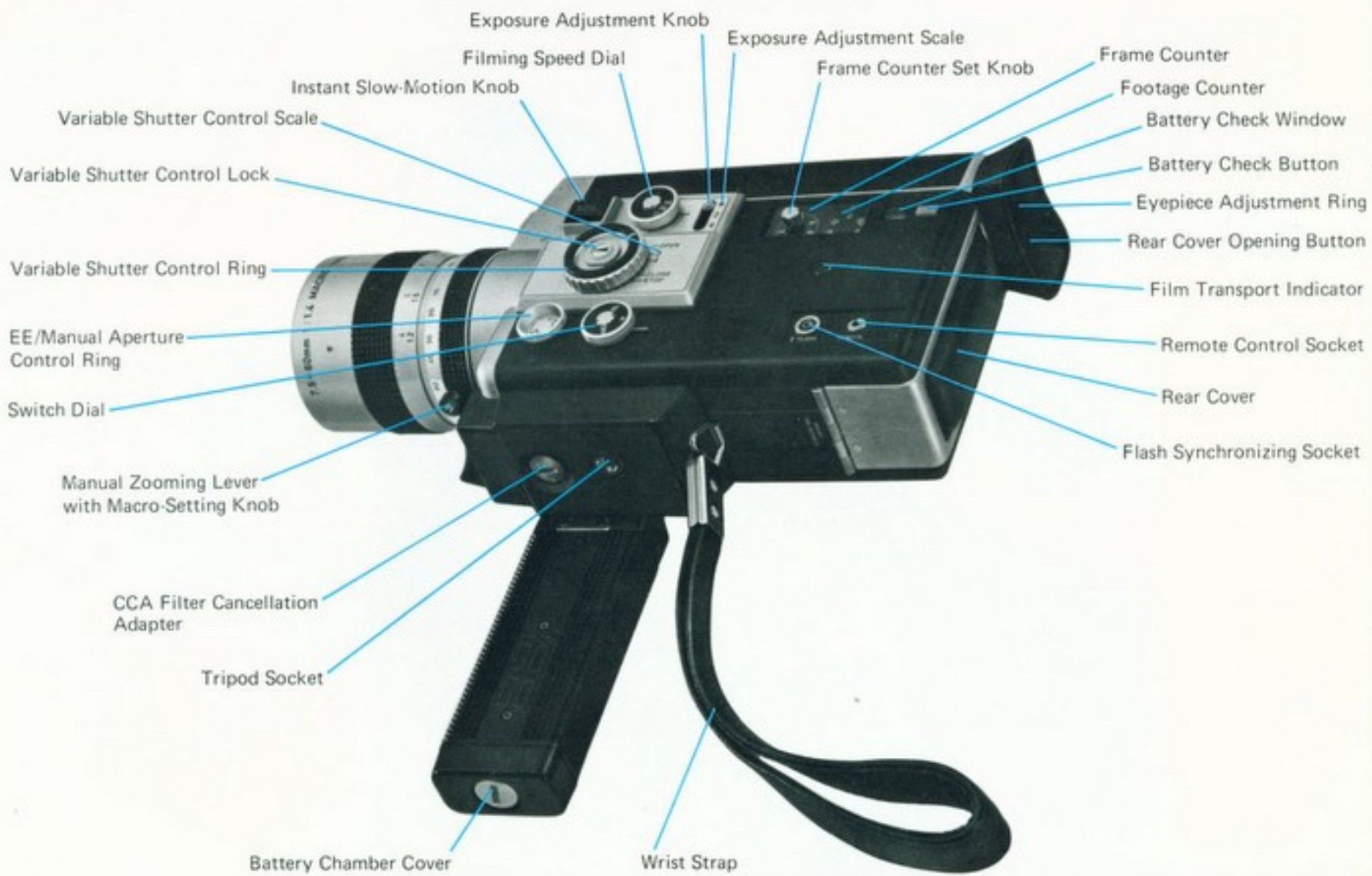
English Edition



-  Socket Cover for Remote Control Socket
-  CCA Filter Cancellation Adapter
-  CCA Filter Cancellation Adapter Socket Cover

Main Features of Canon Auto Zoom 814 Electronic

The Canon Auto Zoom 814 Electronic is the highest-qualified Super 8 movie camera of today, based on the world-renowned Canon Auto Zoom 814 and many new and original qualities added to it. Its mechanisms and materials are researched most carefully and it promises today's finest pictures. The lens is newly developed to make unrivaled fine pictures ideally high-contrasted and clear. To help this ideal lens work best, the Servo-EE meter, which performs precise measurement, is adopted in the EE mechanism. Variable shutter control, macro-shooting system, and the flash socket synchronized with the single-frame pictures are newly developed for this camera. With these characteristics, the Canon Auto Zoom 814 Electronic widens the world of 8mm movie and may proudly be called the ideal of the 8mm movie cameras.

1 Newly Developed large Aperture 8-times Zoom Lens

The unrivaled new lens is based on the former 8-times zoom lens, which has been celebrated for long, and is developed to improve the quality greatly by the enthusiastic technical staff with the help of the computers, and has up to 11 elements of newly developed glass. Therefore, though it has world's prominent brightness of F/1.4, its resolving power and contrast are outstanding.

2 Precise TTL Measurement System

The EE exposure metering system, with the CdS photocell behind the diaphragm and nearest to the focal plane, controls the aperture with a servo meter which accurately measures the incoming light through the lens (TTL). The circuit is not only accurate in response to the light, but very stable against the change of the temperature and the voltage as it adopts all-silicon-transistors. Moreover the minimum diaphragm aperture of f/32 widens the shooting range and increases the accuracy of shooting.

3 Variable Shutter Control

The very high-grade mechanism which controls the opening angle of two semicircular shutter leaves from 0° to 150° continuously. With this mechanism, you can enjoy fading techniques very easily. And because you can change the exposure time regardless to the filming speed, you can avoid blurs even in the sports pictures. The exposure is freely adjusted according to the variable shutter control.

4 Bright Viewfinder Precise in Measuring the Distance

As the aperture of the eyepiece is enlarged, the brightness of the viewfinder has increased and you can see a dark subject very clearly in the viewfinder, so, the microprism screen is designed to equal the characteristics of the human eyes, you can focus most precisely and easily. Moreover, the eyesight magnification is determined on the viewpoint of the human engineering and the eyecup is designed for a man to decide the eye position fitly, and the quality of the viewfinder has been increased very much.

5 Macro-Shooting System Making Super Close-up Techniques at Hand

Macro-shooting has been a field where many accessories and high techniques are required. But with this camera, the close-up technique becomes at hand because it has an 8-times high quality zoom lens with a macro-shooting system and because it requires no accessory. You only have to operate the macro-setting knob and the super close-up shooting is yours. This system promises the outstanding enlargement of the 8mm movie world, not only in general movie but in animation, single frame and title shooting.

6 Electronic Flash Synchronizing System

An electronic flash synchronizing socket is built-in coupled to the single-frame circuit. Electronic flash-synchronized shooting is possible with combined use of accessories.

7 Systematization of Accessories Completing Tiem Interval Shooting

- Interval Timer E enables memo-motion shooting.
- Time Lapse Programmer enables:
 - 1) Memo-motion shooting
 - 2) Work-sampling shooting
 - 3) Indented work-sampling shooting
 - 4) Memo-motion electronic flash shooting
- Self timer E.
- These timers are under development.

8 Other Features

Easy drop-in type of film loading, one electric source powering film driving motor, zooming motor and exposure meter, and built-in amplifier stabilizing electric source, film-end caution lamp.

Canon

AUTO ZOOM 814

ELECTRONIC

We are highly gratified that you have selected the Canon Auto Zoom 814 Electronic — a wise choice that promises you many delightful years of photographic experiences.

Canon is recognized the world over as the foremost pioneer in the development of photographic equipment of the highest quality and performance.

Whether it is for the home, laboratory, or traveling, make the most of your opportunities.

A whole new world of home movie enjoyment will be opened to you!

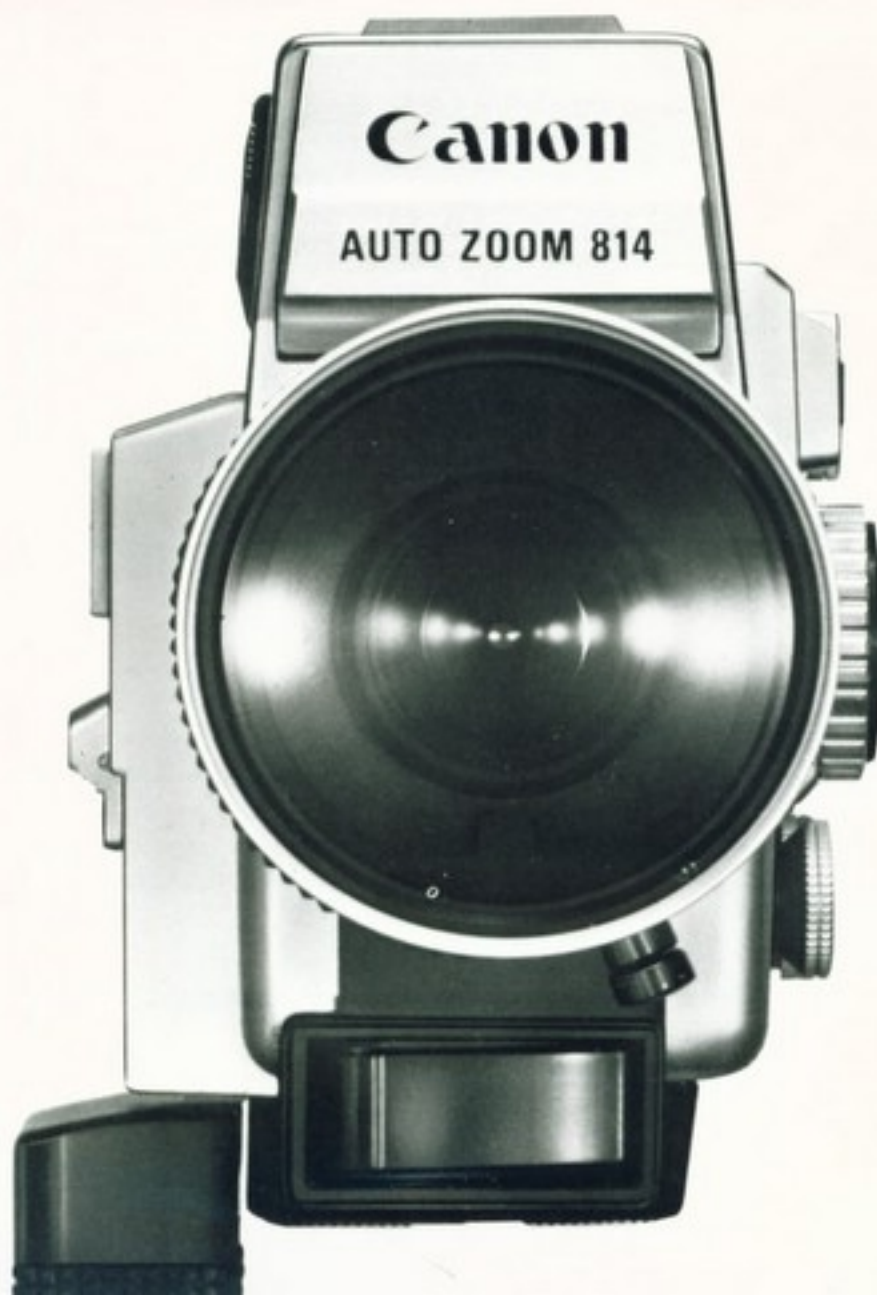

Setting-Up

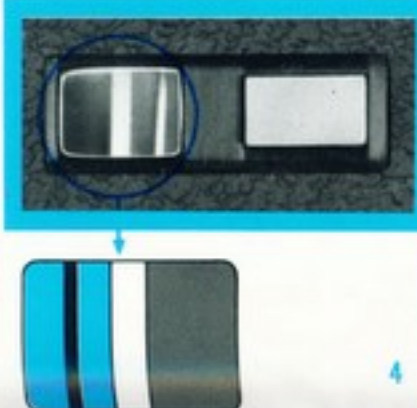

1 Unfold the handgrip.

2 Load the batteries.

3 Turn the switch dial to "R".

4 Check the batteries.

5 Remove the lens cap.

6 Adjust the eyepiece to your individual eyesight.

7 Insert the film cartridge.

8 Make sure that the EE/Manual aperture control ring is pushed in.

9 Set the variable shutter control ring at "OPEN".

10 Set the filming speed at "18".

11 Set the exposure adjustment knob at •.

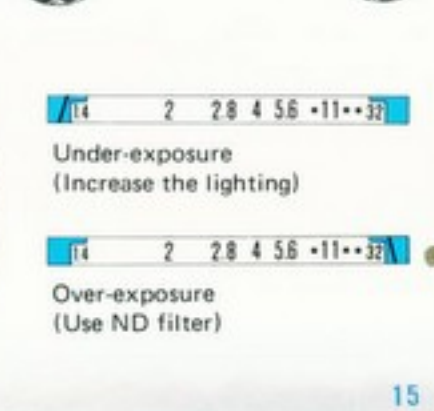

Operation

- 12 Hold the camera and look through the viewfinder.
- 13 Focus at the subject at the maximum magnification (60mm).
- 14 Decide the composition of the picture by turning the zooming ring.
- 15 Pull the trigger slightly to confirm the exposure needle is stable.



- 16 Pull the trigger deeper to start filming.
- 17 During shooting, zoom in and zoom out according to your needs.
- 18 The film-end caution lamp lights up 2.5 feet before the film-end. Continue to run the film to the end (50 ft), and pull out the cartridge.

Manual Aperture Control Shooting	20
Variable Shutter Control	21
Adjusting the Exposure with the Variable Shutter Control	21
How to Use the Variable Shutter Control Ring	21
Fading Effects	22
Various Use of the Shutter	24
Running Lock, Remote Control, Single Frame	
Cancelling the CCA Filter and Taking Pictures in Artificial Light	26

Macro-Shooting	27
Combination Use of Macro Shooting and Zooming Effect	29
Electronic Flash Pictures	30
Unmanned Time Control and Interval Shooting	31
Accessories	32
Close-up lenses, Filters, Copy Stand 4	
Underwater Housing C-8 Cine Projector S-400	

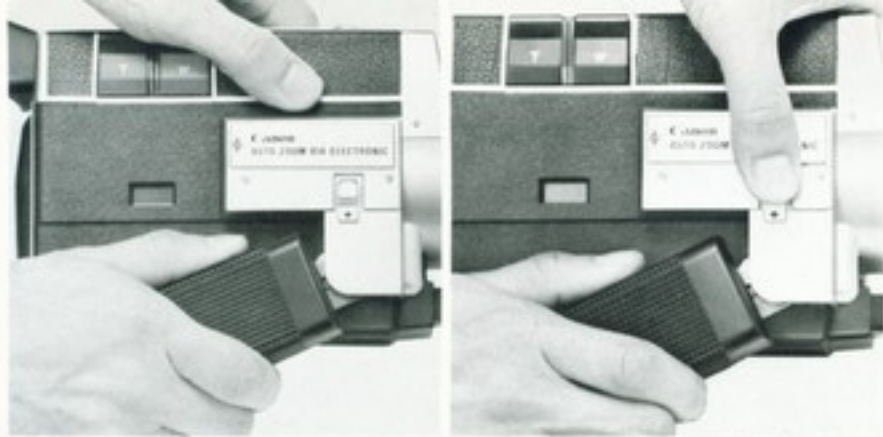

Setting-Up

1 How to Use the Handgrip

The handgrip also serves as a battery chamber. It is automatically locked firmly when turned out. To fold it, push up the handgrip lock and turn it to the former position.

2 Loading the Batteries

- Prepare four penlight (AA size) batteries which power the film driving system, the auto-zooming system, and the exposure meter at the same time.
- Remove the battery chamber cover at the bottom of the handgrip by screwing it counter-clockwise with a coin.
- Insert the batteries confirming \oplus and \ominus as indicated on the diagram and close the cover.

3 Checking the Batteries

If the voltage is not enough the camera does not work properly. So you are well advised to check the batteries occasionally.

- Turn the switch dial to "R", push the battery check button and read the needle in the check window.
- When the needle points to the blue zone, the voltage is enough and you can use any technique. Single frame shooting, slow-motion and shooting at 24 fps are exactly performed when the meter needle is in the blue zone; in the white zone, the voltage is enough only to run the film at 18 fps. When the needle is in the red zone, the voltage not enough and you should change the batteries.
- Even when the camera works with the needle in the red zone, the voltage is not enough to operate the exposure system properly, so be sure to change them.

4 Changing the Batteries

- Choose four high-quality penlight batteries (Size AA) of the same brand and change all of them at the same time.
- When it is out of use, keep the switch dial at "OFF" to prevent the camera from undesired operation.
- When the camera is out of use for a long time, be sure to remove the batteries and keep them in a dry place.

5 Eyepiece Adjustment

- Look into the viewfinder while directing the camera to a bright subject. Rotate the eyepiece adjustment ring till you can see the lines of the prism screen clearly in the center of the viewfinder.
- Without adjusting the eyepiece to your individual eyesight, you cannot focus correctly.
- Adjustable range is from -3 to $+2$ diopters.

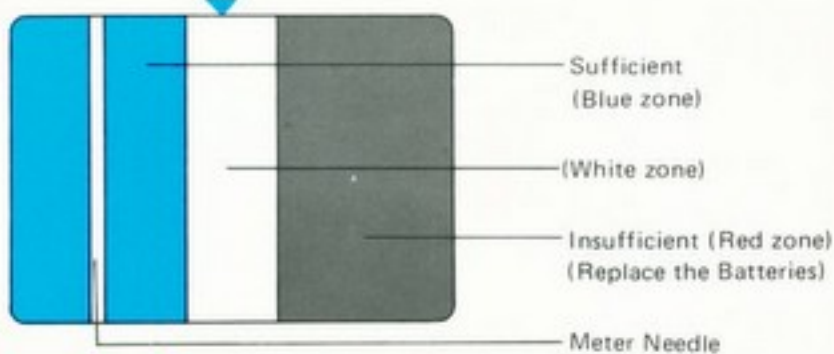
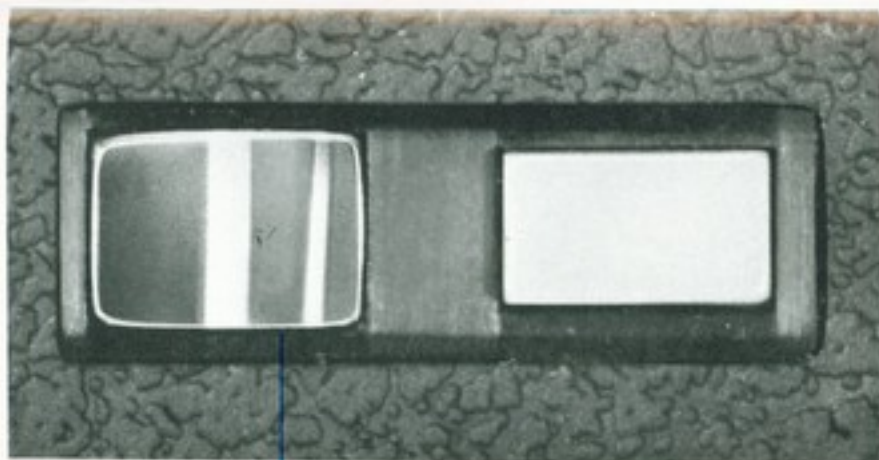



6 Loading the Film

- Open the rear cover by pushing the rear cover opening button.
- Insert the film cartridge facing the identification label to the film type window.
- Close the rear cover by pressing it to the former position. When you hear a click the cover is locked.

FILM SPEED

The film speed is automatically set with the insertion of a film cartridge and no manual adjustment is required.

The following film cartridges can be used.

Tungsten type :	ASA	25	40	64	100	160	250	400
Daylight Type :	ASA	16	25	40	64	100	160	250

FOOTAGE COUNTER

The footage counter indicates the length of the film already exposed. When the cartridge is removed, the counter automatically returns to "0".

- When the cartridge is out, the counter does not work.

FRAME COUNTER

One rotation of the counter equals to 72 frames (1 ft).

To set the frame counter, rotate the frame counter knob and set the indication needle at "0" of the counter, and you can see how many frames you have exposed. It is especially useful in fading techniques or in single frame pictures.

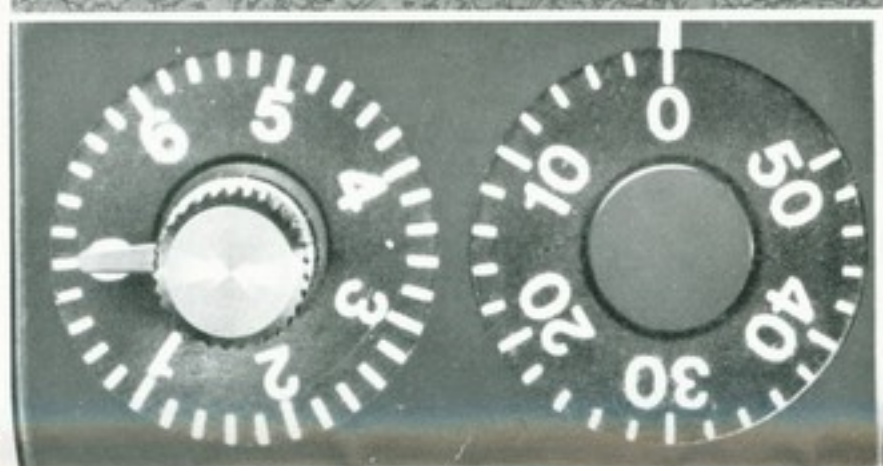

Preparations for Electric Eye Operation

- 1 Set the switch dial at "R".

All the electric circuits are on and the shutter is ready to work. "OFF" is the safety position at which the electric source is off to prevent the shutter and the exposure meter from undesired operation. "RL" is for the running lock and for the remote control (See page 24).

- 2 Make sure that the EE/Manual aperture control ring is pushed in.

If the EE/Manual aperture control ring is pulled out, the camera is switched to manual operations and the EE exposure control does not work.

- 3 Set the variable shutter control ring at "OPEN".

The variable shutter control ring is used when you adjust the exposure with the variable shutter or perform fading.

- The variable shutter control lock is released when it is pressed in the direction of the arrow and you can rotate the control ring freely. Then set it at "OPEN" and press the lock back to the former position to lock it.
- The variable shutter control can be locked only at "OPEN", "2", and "4".

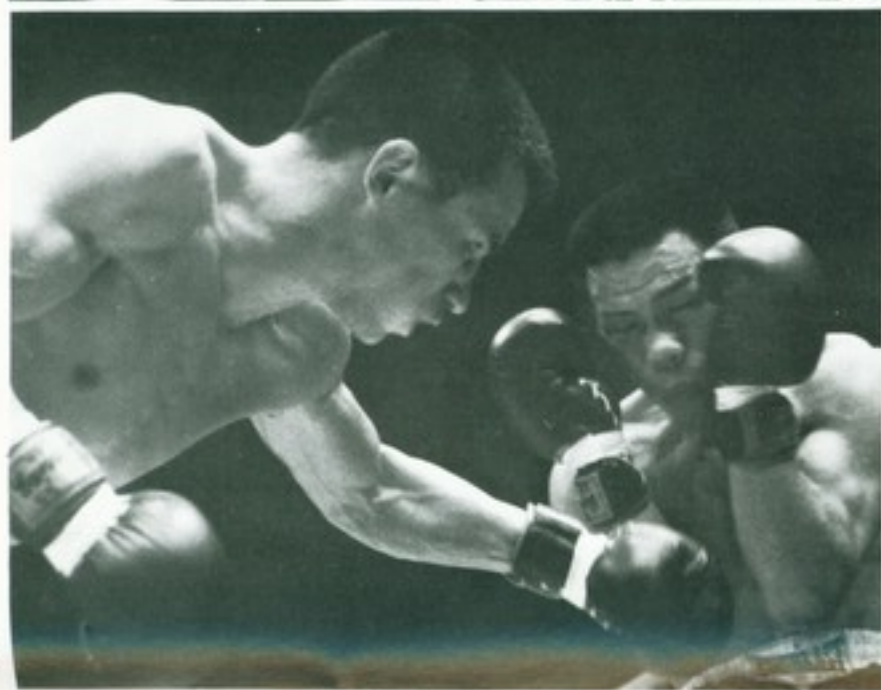

4 Set the filming speed.

18 fps is the standard filming speed of the Super 8 movies. Turn the filming speed dial and set at "18", and you hear a click.

- Do not film when the dial is set anywhere between the numbers. It should be set at the exact number.
- It is most natural to project the film at 18 fps which was exposed at 18 fps.
- When the film is projected at 18 fps, which was exposed at 24 fps, the motion is 1.3 times slowed down. Use 24 fps when you want the following effects :
 - Making standard sound film
 - Slowing down the motions
 - Lengthening the zooming time
 - Avoiding blurring while panning

SLOW MOTION

• The instant slow-motion knob is for high-speed shooting and the film runs at about 40 fps. When you press down the instant slow-motion knob during taking pictures at 18 or 24 fps, the filming speed changes at once for slow-motion shooting, and when you release the knob the speed returns to the former speed and you can continue taking pictures without interruption. With the use of this system you can easily change the scenes from the standard speed to the slow-motion or from the slow-motion to the standard speed and the scenes may get varieties.

If you want slow-motion pictures from the start, press down the knob first, then pull the trigger ; and to stop it, release the trigger first, then the slow-motion knob.

• The instant slow-motion knob works only when it is pressed down. Be careful not to release it during the slow-motion pictures.

• The instant slow-motion knob should be pressed down quickly. If it is pressed slowly, exact exposure is not obtained.

• The instant slow-motion knob is useless in the single-frame pictures. If the knob is pressed during the single-frame pictures, the frame will be over-exposed.

In the slow-motion picture, the film is driven about two times faster than ordinary shooting and the exposure time becomes about half as that of ordinary shooting.

This technique is useful in the following cases ;

- To slow down the motion
- To avoid blurs during panning or while you are moving

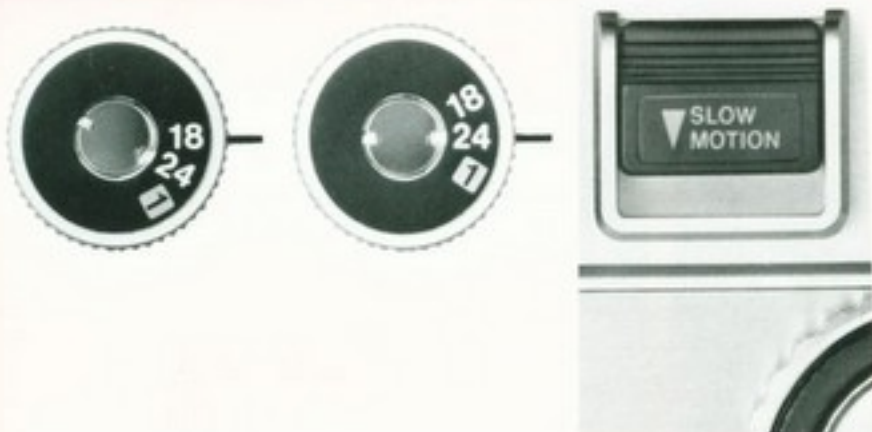

5 Set the exposure adjustment knob at •.

• If the knob fails to be at • during ordinary electric eye operation, correct exposure will not be attained.

6 See the film transport indicator.

Looking at the film transport indicator, pull the trigger and run the film slightly. If you hear the running sound and see the white point rotate, the film is driven properly. If the white point does not move, insert the film cartridge again correctly.



Operation (1)

1 Holding the camera

Hold the handgrip with your right hand and place the forefinger on the trigger. Focusing and zooming are done with the left hand.

• If the camera is not held firmly enough during shooting, the scenes may become unstable and unenjoyable while projecting. Be careful especially in the telephoto pictures or in zooming. It is advisable to use a firm tripod and Remote Switch 60 or Remote Switch 3, or keep your right elbow pressed firmly against your body.

2 Look through the viewfinder

You can get every required information in the viewfinder because the diaphragm scale, the exposure meter needle, the exposure warning marks, the prism screen range finder, and the film end caution mark are built in it.

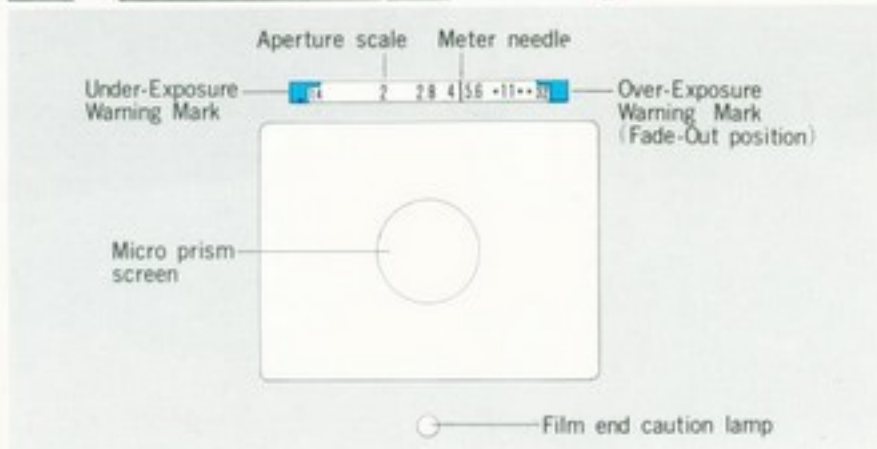

3 Zooming

When you rotate the zooming ring manually or push the power zooming button, the magnification of the subject changes. Therefore, you can compose the frame easily and you can add to your pictures zooming effects, that is, continuous changing of the magnification.

POWER ZOOMING

Zooming begins by pressing either of the power zooming buttons. The magnification changes with the button "T" toward the telephoto area, and "W" toward the wide-angle area. When you push the buttons during shooting, zooming effects are easily gained. The zooming time in the full range is about 7 to 8 seconds.



MANUAL ZOOMING

The power zooming system gives the zooming effect in a fixed time. If you want a more rapid, or slower zooming effect, or when you aim at more exact composition, perform with the manual zooming ring.

- The viewfinder magnification is in the life-size when the focal length is at 15mm.
- Effective manual zooming technique may be obtained by repeating practice. In manual zooming, zoom with the finger placed on the top of the manual zooming lever. Do not pull up the manual zooming lever because it may turn to the macro-set position.



4 Focusing

Rotate the focusing ring while looking through the viewfinder till the subject on the prism screen in the center of the viewfinder can be seen most clearly. You can focus more easily and exactly at the longest focal length.

• Once the subject is focused, it is always in focus even during zooming. Therefore, it is advisable to first focus at maximum magnification (telephoto) and then return to the required magnification.



5 Composition

The viewfinder is of the single-lens reflex type and has no parallax. All that you see in the viewfinder will be exposed on the film. Decide your composition in the full frame. The framing of the subject can be decided by changing the distance to it or by zooming.

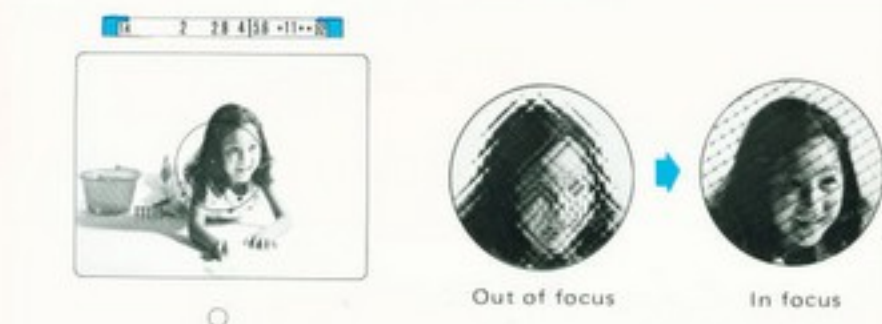

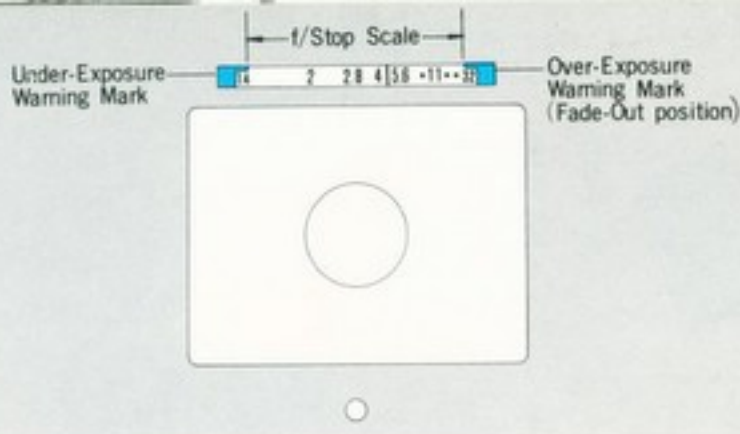

6 Check the exposure indicator

The trigger works in two steps.

By pressing it slightly, the exposure meter circuit is turned on. The meter needle first swings rapidly and then indicates the proper exposure. When the needle is out of the red warning marks, you are ready to shoot. Pull the trigger all the way to begin filming.

- The exposure meter does not work if the switch dial is set at "OFF". If the needle is in the left red warning mark, it means under-exposure, and so lighting must be increased. If the needle is in the right red warning mark, it means over-exposure, and so adjust the exposure with the variable shutter control or use an ND filter (page 21).

- When the trigger is not pulled, the needle stays in the right red warning mark.

- When the trigger is pulled while the switch dial is set at "RL", the meter is working continuously and the needle moves according to the brightness of the subject.

7 Pull the trigger deeply

The film begins running and you start shooting. Zooming and panning techniques add variety to your pictures.

PANNING

Panning is employed when shooting a scene from one position to another by moving the camera around horizontally to make a continuous shot over a wide area in one sequence.

- Do not move the camera too rapidly in any direction, particularly vertically. Use of a tripod is recommended.

- Panning shots are usually started from subjects of less importance and move on to the most important subject where it ends by running the film longer on the last sequence.

8 End of the shooting and removing the film cartridge

A Super 8 cartridge contains 50 feet of film of one way running. With this camera, when 47.5 feet of the film has been exposed, an orange caution lamp lights up at the bottom of the viewfinder to notice that the film will end in 2.5 feet. After the film end caution lamp lights up, take notice of the remains of the film and run it fully 50 feet. Then open the rear cover and remove the film cartridge.

- When removing the cartridge, pull the cartridge removing lever under the cartridge guide and you can easily remove it.

- When the full 50 feet of the film has been exposed and when the film has stopped running, the running sound changes and you can notice it. Confirm it by the footage counter.

- The exposed film has a cut-out on the perforations and is distinguished from the unexposed one.

- Send the exposed film promptly to an authorized processor.

9 Changing a film on the halfway

A Super 8 movie camera uses a cartridge. Therefore you can exchange cartridges of different type film even on the halfway of one cartridge. You lose only 2 inches or less loss of film, including behind and before the naked part of the film in the exposure window of a cartridge, by exchanging the cartridges on the halfway.

Cautions for changing the cartridges on the halfway.

- To prevent the last pictured scene from undesired exposure, run the film vacantly a little before changing the cartridge.

- By changing the cartridges the footage counter automatically resets at "0". So we advise you to read the footage counter before removing and put it down on the removed cartridge as a memo.

- The film end caution lamp is combined to the footage counter and does not light if a half-used cartridge is loaded. Confirm the film end with the footage counter or film driving sound.

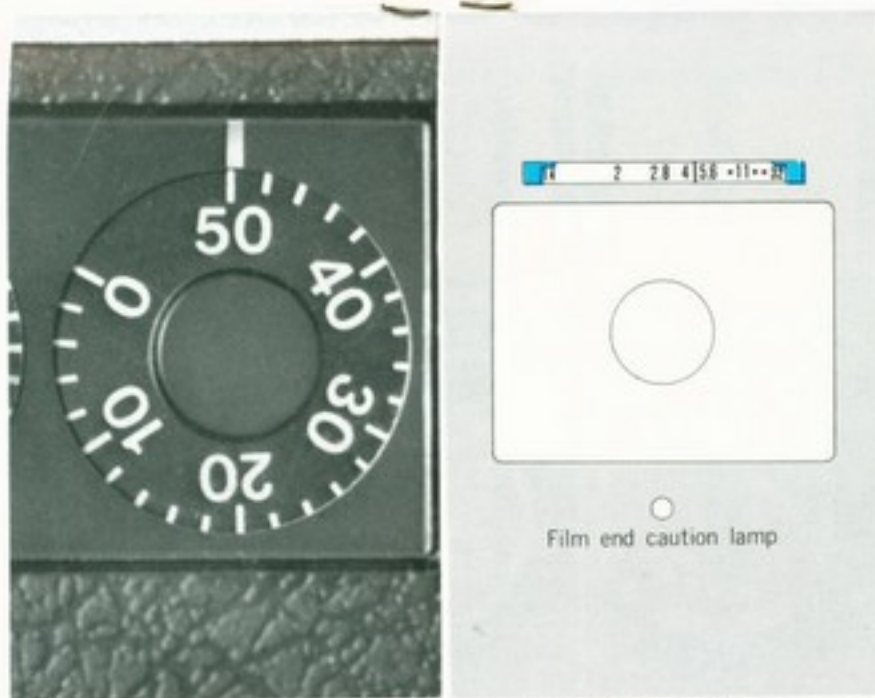

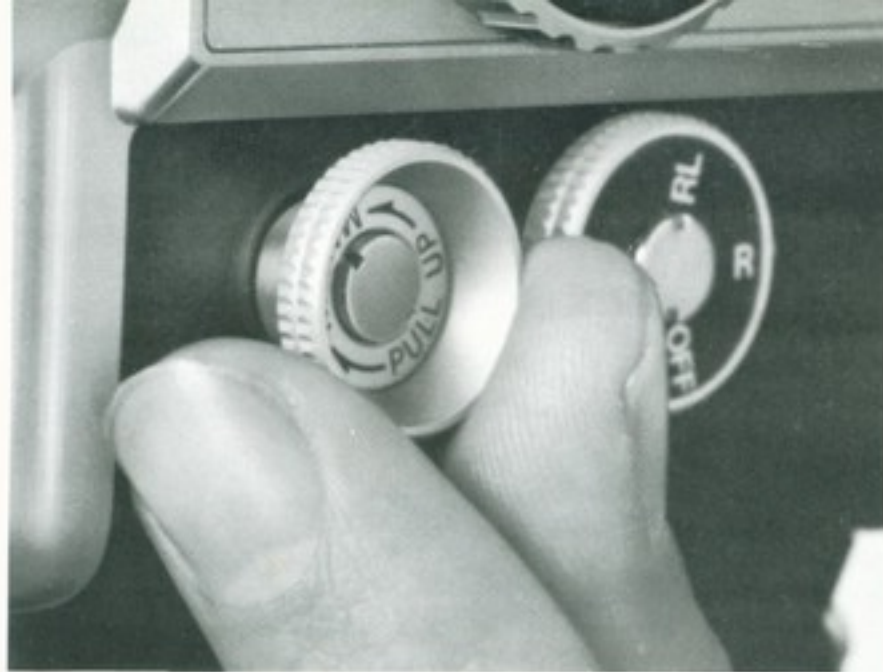

Operation (2)

Manual Aperture Control Shooting

When the EE/Manual aperture control ring is pulled out, the EE mechanism is released and you can set the aperture manually. Turn the EE/Manual aperture control ring looking at the exposure indicator in the viewfinder and decide the exposure. This method is especially useful when you take a subject against the light, or when you want an emphasizing effect such as a high-key or low-key effect. When you push in the EE/Manual aperture control ring, you can perform EE picture shooting again.

- When the EE/Manual aperture control ring is pulled out, the indicator in the viewfinder moves to the left edge.
- When the EE/Manual aperture control ring is turned clockwise the aperture opens, and counter-clockwise closes. When the needle is in the red warning mark on the left edge or on the right edge, it does not move anymore even when the ring is rotated to the same direction. In such a case, rotate the ring to the reverse direction and set it at the desired f/stop.
- Even if the EE/Manual aperture control ring is rotated too much, it does not affect the exposure meter nor the indicator.
- When you change filming speed from 18 fps. to "SLOWMOTION" in manual aperture control, stop shooting and open the aperture by one f/stop. Then start slow motion shooting.
- In manual aperture control of flash pictures, it is recommended to select the aperture between f/5.6 and f/11 by adjusting the lighting intensity, and to take distance of more than 1 m from the flash to the subject. Then you will get excellent result.

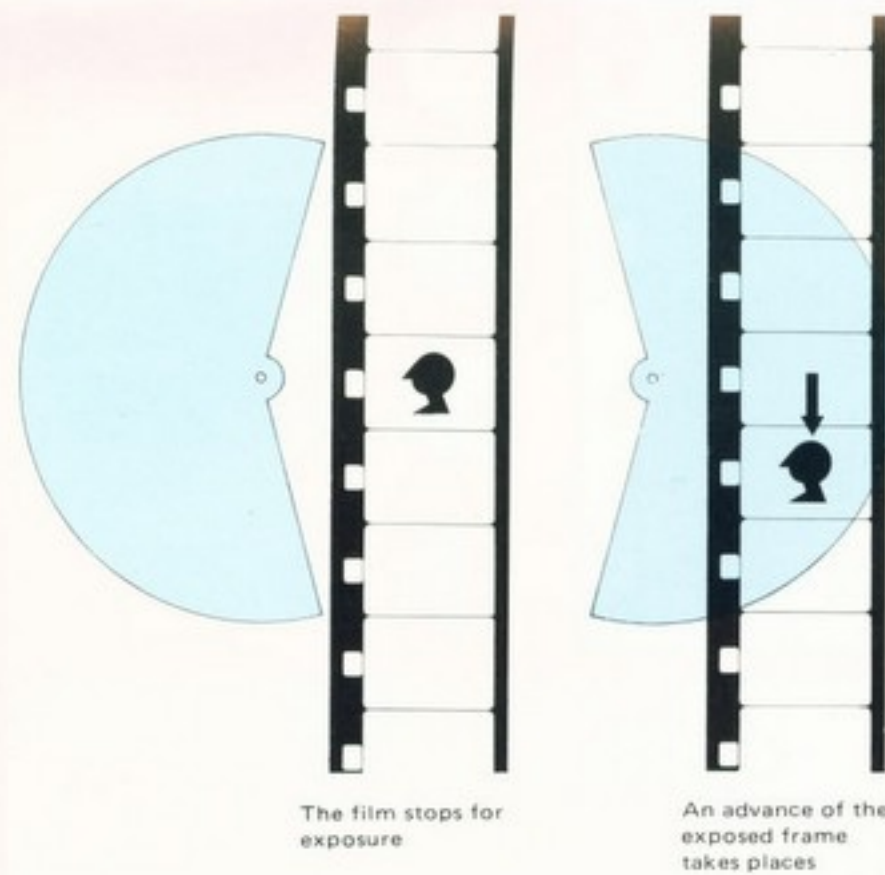
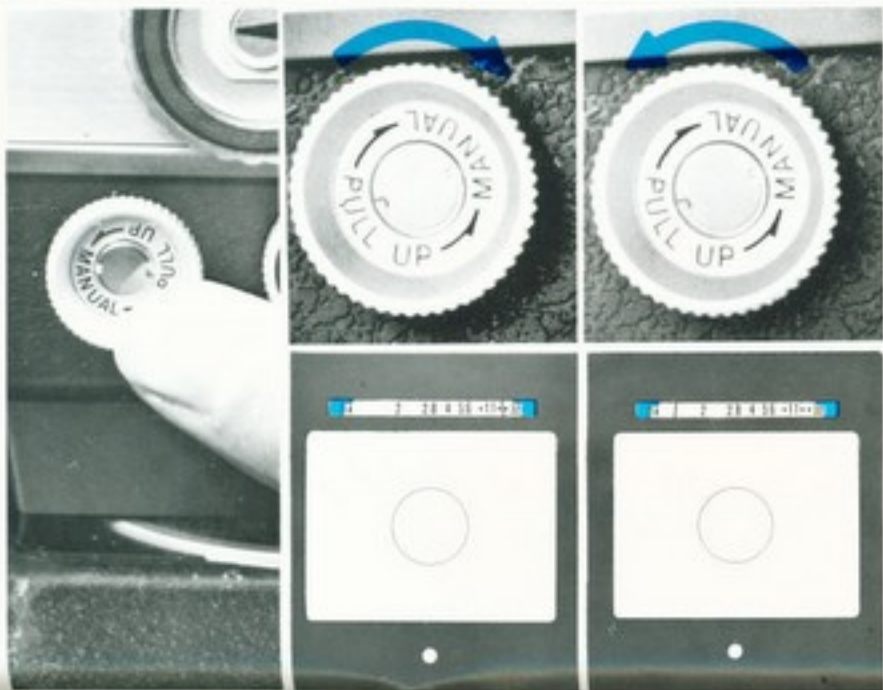

Variable Shutter Control

The shutter of an 8mm movie camera is combined to the film advance. The exposure is decided by the rotation of two semicircular leaves with a given angle. In one rotation, one frame is exposed and advanced in combination. That is, when the open part of the leaves faces the aperture gate the film stops for exposure, and when the leaves shut the aperture gate the film advances. Therefore the exposure is changed according to the rotation speed and the open angle of the leaves. The rotation speed equals to the filming speed. And the open angle of the leaves is called variable shutter angle. This camera has a built-in mechanism to control the shutter angle, with which you can control the exposures on the film. And you can also perform the fading techniques with it.

Adjusting the Exposure with the Variable Shutter Control

The filming speed of an 8mm movie camera can not be changed at will, because the filming speed of an 8mm movie camera is normally decided to equal to the projection speed of a projector. Therefore the exposure of an 8mm movie camera is generally controlled by the aperture control. Then the variable shutter is developed to control the exposure with the shutter itself as well as with the aperture. That is, the exposure is adjusted by means of the shutter angle at the same filming speed.

In the Canon Auto Zoom 814 Electronic, the shutter angle is variable from 150° to 0° continuously. A four-step scale is marked on the body to make the exposure control and fading techniques easier.

In ordinary shooting the variable shutter control is set at "OPEN". When in need the exposure can be controlled by rotating the variable shutter control ring as much as required toward the "CLOSE" position.

How to Use the Variable Shutter Control Ring

- 1 Release the variable shutter control lock by pressing in the direction of the arrow.



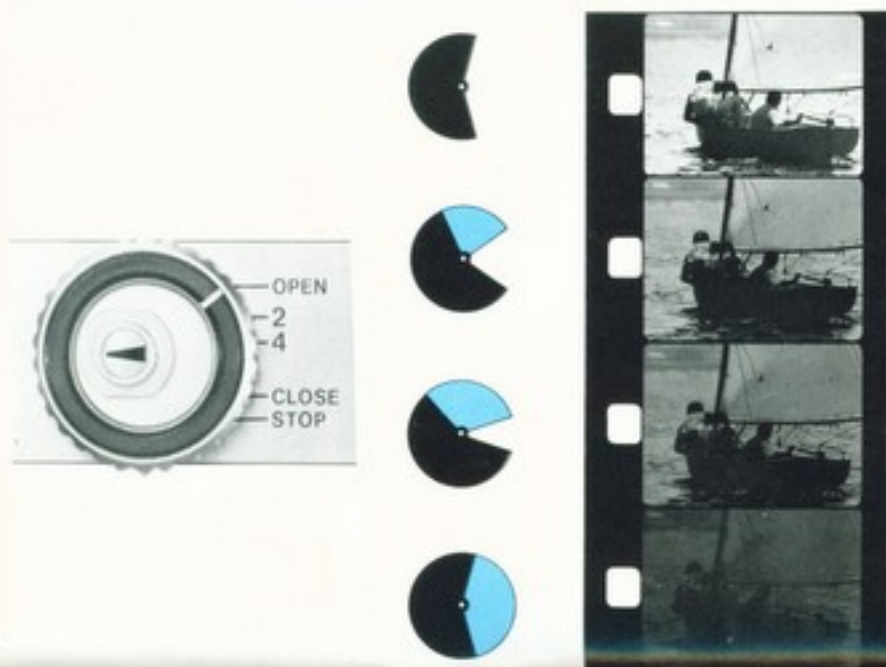
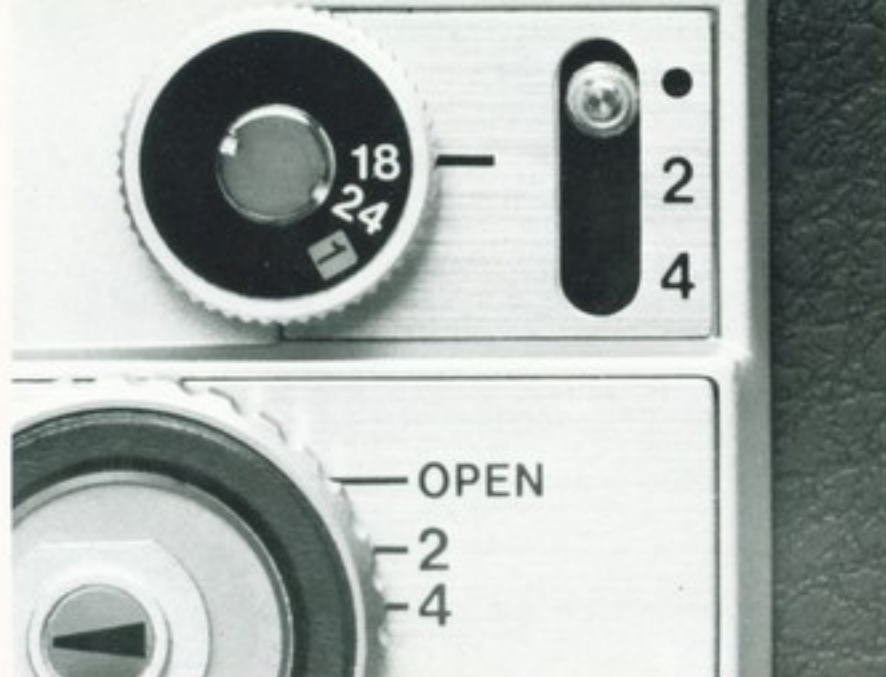

- 2 Rotate the variable shutter control ring. When it is set at "2", the exposure becomes 1/2 as much as at "OPEN" regardless of the filming speed. When it is at "4", the exposure is 1/4 of "OPEN".
- 3 Use the variable shutter control in such cases as the subject blurs in a too fast motion or as the light is too much to be measured by the built-in exposure meter.
- 4 When you use the variable shutter control in EE operation, set the exposure adjustment knob beforehand at the same number of "2" or "4" respectively.

*When the variable shutter control ring is at OPEN, set the exposure adjustment knob at ●.

RELATIONS OF THE VARIABLE SHUTTER CONTROL AND THE FILMING SPEED

Variable Shutter Control	Open Angle	Exposure Adjustment Knob	Exposure Time (Each Frame)	
			18 fps.	24 fps.
OPEN	150°	●	1/43 sec.	1/58 sec.
2	75°	2	1/86 sec.	1/115 sec.
4	37°	4	1/173 sec.	1/230 sec.
CLOSE	0°	—	closed	

Fading Effects

FADE-OUT

By rotating the variable shutter control ring from "OPEN" to "CLOSE" while running the film, the shutter angle becomes narrower and the exposure gets lowered accordingly and the scene dissolves gradually into the complete darkness at "CLOSE". This effect is called a fade-out.

When you continuously rotate the control ring to "STOP", the film stops automatically to prevent from running in vain though the trigger is still pulled.

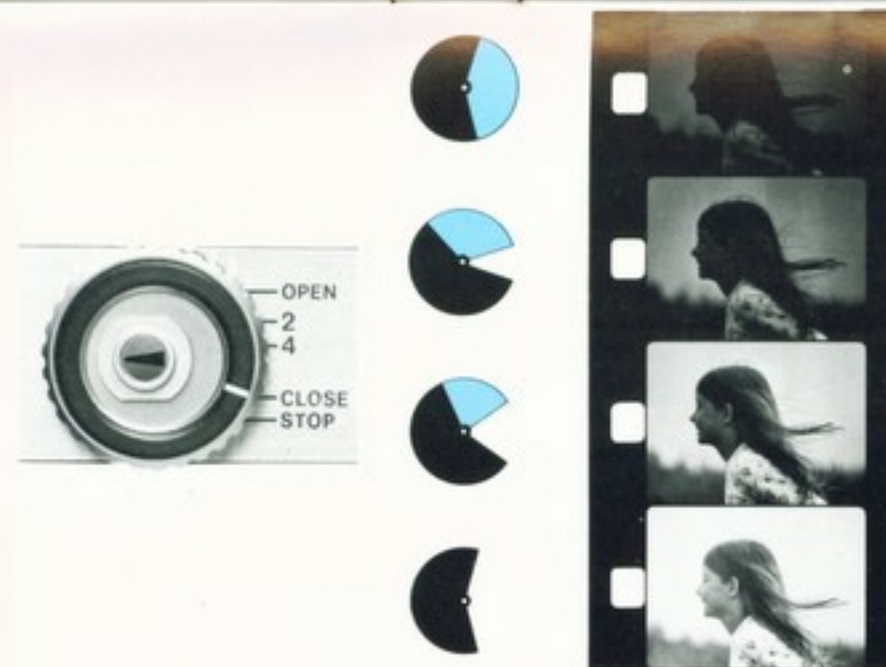

FADE-IN

By rotating the variable shutter control ring from "STOP" through "CLOSE" to "OPEN" gradually while pulling the trigger, incoming light gradually increases, and fade-in technique can be performed.

• The fading techniques are very important on changing the scenes, on the introduction of a scene, or on giving an end to a scene in the movies. The fade-in is generally used at the introduction of the whole film and the fade-out at the end. When the fading effects are used in the middle of a movie, they describe a great change of the scenes or a long time passing. So these techniques should not be used so often. In general, a fade-in, or a fade-out in changing the scenes is advisable to be within 2 to 3 seconds, and at the introduction or at the end to be within 4 to 6 seconds.



Variable Use of the Shutter

■ Running Lock

The running lock is for continuous shooting. Set the switch dial at "RL" and pull the trigger. The shutter is locked at the running position and the film keeps running even if you remove your hand from the trigger. When releasing the lock, return the switch dial to "R".

■ Remote Control

Remote control EE shooting is possible with combined use of Remote Switch 60 or optional Remote Switch 3, and it is convenient when you set the camera far from you. Remote Switch 60 has a cord of 60cm (2 ft) length for general shooting or for avoiding the blurring in single frame shooting. The cord of Remote Switch 3 is 8 meters (26 ft) long.

- 1 Set the switch dial of the camera at "OFF" and connect the plug of the remote switch to the remote control socket on the camera.
 - 2 Then set the switch dial at "RL" and pull the trigger as with the running lock. You can set the switch dial while pulling the trigger.
 - 3 When you push down the switch button of the remote switch, the film starts running, and when you slide it following the arrow while pressing it, the switch is set as a running lock.
 - 4 When you use a remote switch in manual aperture control operations, read out the proper f/stop number in the viewfinder and set the aperture by pulling out the EE/Manual aperture control ring and by rotating it.
 - 5 When you remove the remote switch from the camera, be sure to turn the switch dial of the camera to "R" or "OFF" beforehand, otherwise the shutter begins working on removing the remote switch and you will waste the film.
- When the remote switch is out of use, be sure to set the switch dial at "OFF" to prevent the batteries from being wasted. So be sure to make preparations just before the actual operation.
 - Check the conditions of the subject carefully before you operate the camera from a distance.
 - If the eye is not against the eyepiece, be sure to attach the eyepiece cover.

■ Single Frame Shooting

Canon Auto Zoom 814 Electronic provides magnetic shutter release mechanism, and can perform perfect EE shooting including single frame shooting with combined use of remote switch.

Therefore, Remote Switch is used in place of general cable release.

- Single frame shooting can be performed as follows ; Set the filming speed dial at "1", connect the Remote Switch 60 or Remote Switch 3 to the remote control socket of the camera, turn the switch dial to RL, and press down the button of the remote switch.
- If the switch dial is not set at RL, correct exposure cannot be obtained.
- In the case of single frame shooting without remote switch, set the filming speed dial at "1", and turn the switch dial to R. Decide the exposure manually, and pull the trigger.

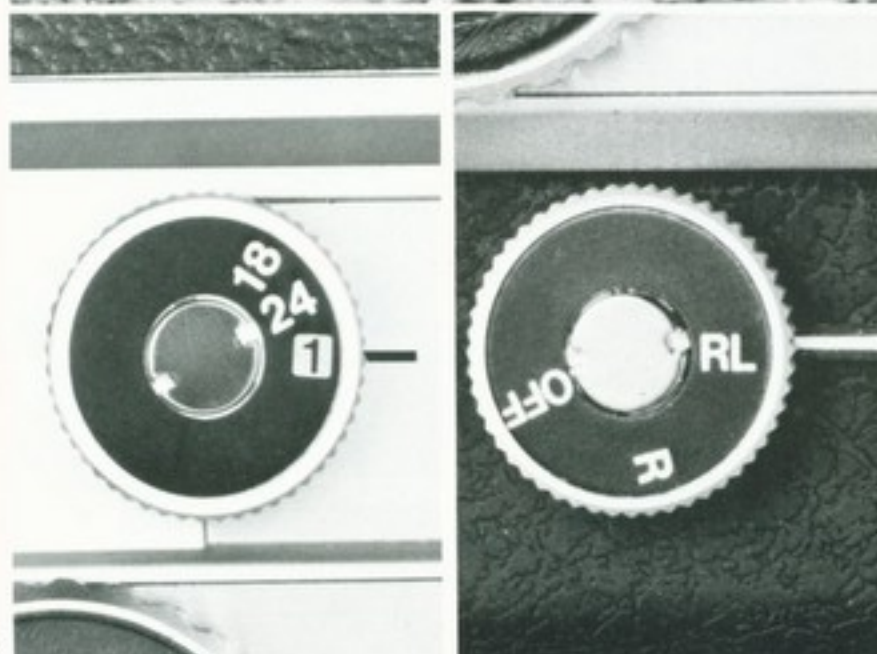
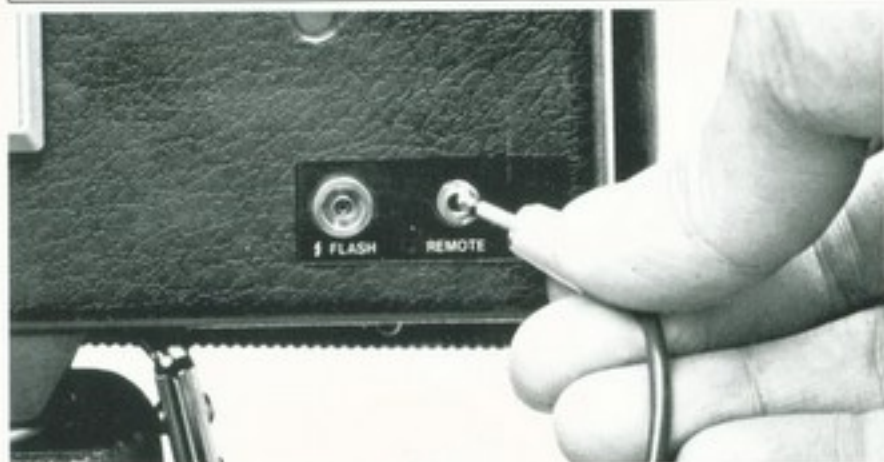

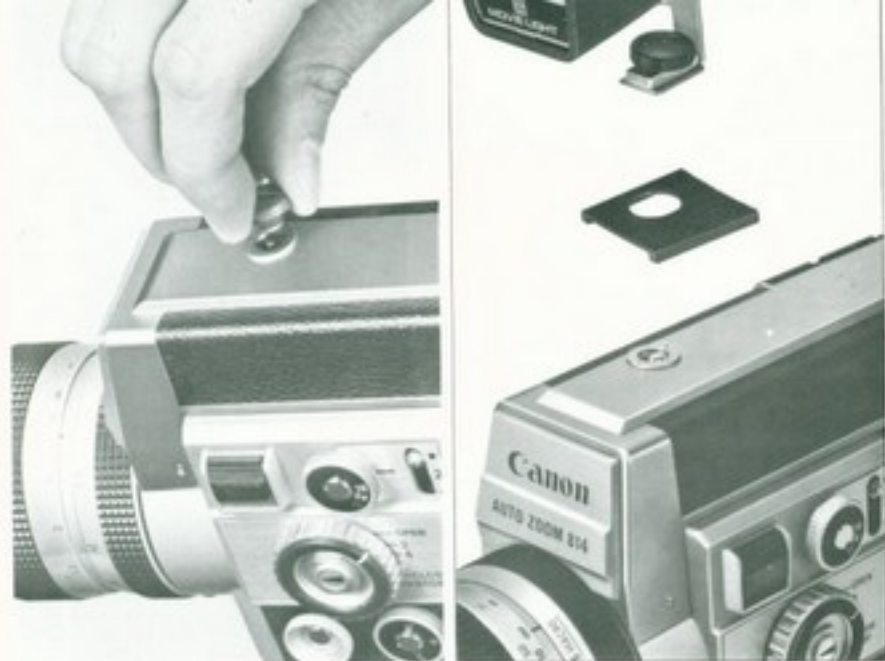

Cancelling the CCA Filter and Taking Pictures in Artificial Light

- 1 A Super 8 camera uses tungsten (artificial light) type of color film and has a built-in CCA filter to adjust the color temperature when it is used in daylight or in "blue lamp" light.
- 2 The CCA filter has to be cancelled when pictures are taken in artificial light. To cancel the CCA filter, screw the CCA filter cancellation adapter held at the bottom of the camera into the socket on the top of the camera, or a lighting unit into it.
 - Connect the lighting unit to the camera firmly, inserting the belonged rubber mat between the camera body and the lighting unit. It is advisable to turn the camera itself in the final step of the connection.
 - When using a high power movie light, avoid going to close less than 1 meter (3.3 ft) to prevent burning of the subject.
 - It is advisable to use a pair of floodlight instead of the powerful lighting unit.
 - Do not use the CCA filter cancellation adapter socket as a tripod socket.
- 3 When a cartridge of daylight type film is inserted, the CCA filter is cancelled automatically.

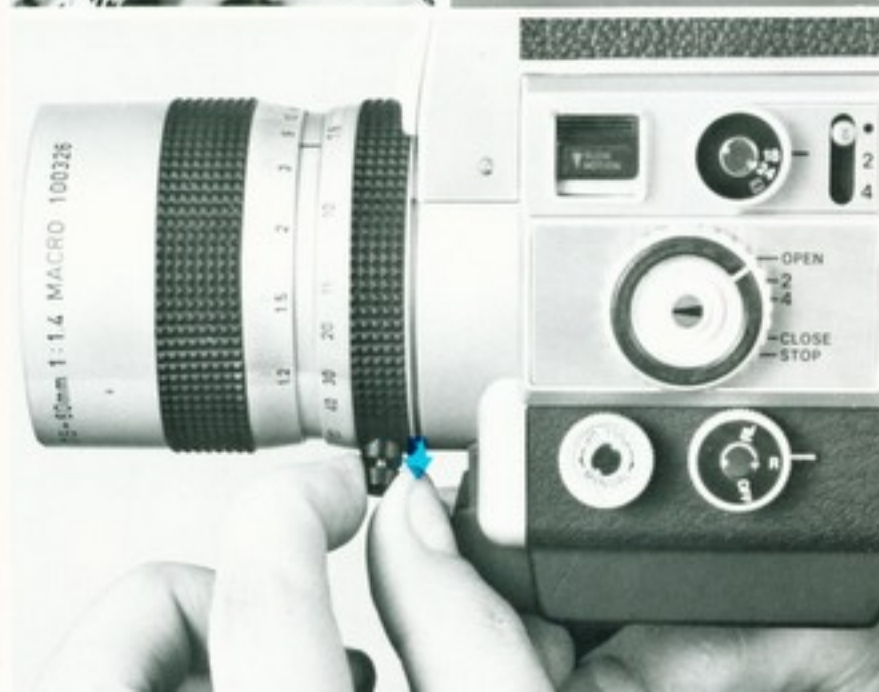

Macro-Shooting

The Canon Auto Zoom 814 Electronic has a built-in macro-shooting system and you can easily take super close-up pictures without using any accessory. Make use of it in shooting small insects, animals, flowers, or in titling.

- 1 Normally, the zooming ring cannot be turned any further once you reach 7.5mm. To use macro range, pull out the zooming lever and you will be able to rotate the zooming ring in the macro range.
- 2 Look through the viewfinder and focus at the subject. As it is rather difficult to focus with the focus ring, adjust the focus by rotating the zooming ring keeping it within the area of "MACRO".
- 3 Blurs are especially displeasing in macro pictures. It is advisable to keep the camera steady by mounting it on a copy stand or on a tripod and to use the Remote Switch 60 in these operations.
 - Be sure to attach the eyepiece cover to prevent reverse incoming light when the eye is not against the eyepiece. Otherwise, direct light may enter from the eyepiece and cause ghost images on the film.
 - In macro shooting, it is advisable to select the aperture between f/5.6 and f/11 by adjusting the light intensity.



4 You can get near to the subject 16.5cm (6.50") from the film plane indicator (33 x 45mm area on the full frame setting the focusing ring at ∞).

5 In macro-shooting, the depth-of-field becomes extremely shallow. So it is most advisable to focus carefully and exactly, and to set the diaphragm aperture as small as possible with the help of brighter lights.
 • Do not use a strong movie light, because it could burn the subject that is being filmed.

DEPTH-OF-FIELD WHEN THE SUBJECT IS AT 16.5cm (6.50") FROM THE FILM PLANE INDICATOR

Diaphragm Aperture	Depth-of-Field	Diaphragm Aperture	Depth-of-Field
1.4	16.4 ~ 16.7cm (6.46" ~ 6.57")	8	15.8 ~ 17.5cm (6.22" ~ 6.89")
2	16.3 ~ 16.8cm (6.42" ~ 6.61")	11	15.5 ~ 18cm (6.10" ~ 7.09")
2.8	16.3 ~ 16.9cm (6.42" ~ 6.65")	16	15.2 ~ 18.8cm (5.98" ~ 7.40")
4	16.1 ~ 17cm (6.34" ~ 6.69")	22	14.8 ~ 20.1cm (5.83" ~ 7.91")
5.6	16 ~ 17.2cm (6.30" ~ 6.77")	32	14.3 ~ 23.5cm (5.63" ~ 9.25")



From the Lens
Tip to the Subject

2.4 cm (1")



30 cm (1')



150 cm (5')



Zoom Up



Combination Use of Macro Shooting and Zooming Effect

In macro shooting, zooming ring is used as the focusing ring. Focus by turning the zooming ring in the macro range indicated by yellow line. Focused range moves between the nearest focal distance in macro shooting and focused distance set beforehand with focusing ring.

For instance, if you turn the zooming ring after setting the focusing ring at 1.5 m (5 ft.), focused range moves from the nearest distance to 1.5 m. If the zooming ring is turned further, macro shooting mechanism is released and focal distance is set at 1.5 m.

When zooming is continued, the subject at the distance of 1.5 m is zoomed up.

If the focusing ring is set at infinity, focused range moves from macro range to infinity and after the macro shooting mechanism is released at the focal distance of 7.5 mm, you can change macro shooting to zooming.

Utilizing this method, you can change the scenes from the closest subject to the others and zoom them up, and it is effective in making clear the situation of the subjects or in changing the image of the scenes.

This technique adds outstanding effect to ordinary zooming.



Electronic Flash Pictures

This camera has a built-in flash synchronization socket (X contact). When you take a title or animation film with single-frame, an electronic flash unit can be used. First connect the flash mounting adapter to the camera, then a flash unit or an electronic flash unit to the adapter. When you use a flash unit, the aperture must be controlled manually. The proper f/stop number is calculated by dividing the guide number by the distance between the light and the subject. Set the proper f/stop according to the GN listed in the instruction book or on the calculation panel of the flash unit. In this case, use the same unit for both the GN and shooting distance. For example, if the shooting distance is in feet, the GN should be in feet. Do not mix the units of meters and feet.

- It is recommended to select the aperture opening between f/5.6 and f/11 to get excellent results.
- Set the variable shutter control ring at "OPEN". Otherwise, flash synchronized shooting cannot be performed. Shutter speed is approximately 1/42 sec. But actual exposure is the same as the flash period of the Speedlite.

If using an electronic flash unit, be especially careful in fixing the exposure setting. Because the still camera has a light requirement just for a single picture, whereas the 8mm cine camera requires the same light intensity from the flash unit for successive frames. To prevent blinking of image, use Canon's exclusive Speedlite, because it incorporates a stabilized power level circuit delivering consistently better results. If using a conventional electronic flash unit without stabilized power level circuit, (1) shoot as soon as the pilot lamp lights up, or (2) open the f/stop by one scale or half scale; or use the AC power source.

- A discharge tube of an electronic flash is said to bear about 5,000 operations, that is, about 1.5 cartridges of Super 8 film. Keep this in mind in single frame shooting.
- In electronic flash pictures, cancelling the CCA filter is not necessary.
- The flash mounting adapter is in preparation.

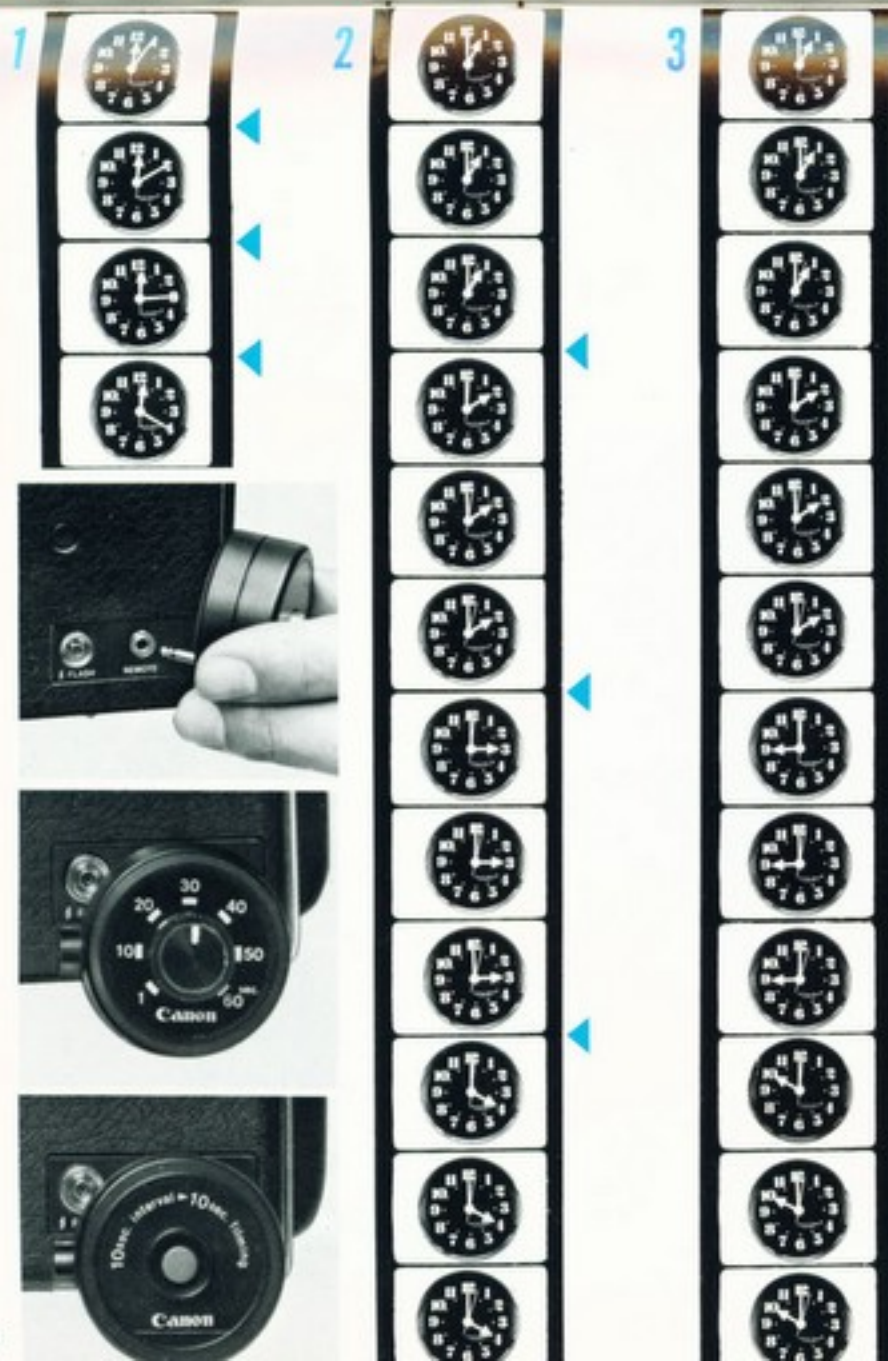

Unmanned Time Control and Interval Shooting

Time control and interval shooting is useful when shooting continuous change of the subject for a long time. The shutter is released at decided interval and unmanned shooting is possible. There are three ways in this method.

- 1 Memo-motion shooting**
Memo-motion shooting is to take pictures frame by frame at a fixed interval, which is used to document a long and continuous change of the subject. The changing degrees on the film can be controlled by controlling the shooting intervals with Interval Timer E or Time Lapse Programmer.
- 2 Work-sampling shooting**
Work-sampling shooting is the combination of shooting and pausing with combined use of Time Lapse Programmer. It is applied to shorten the time of the continuous changes to the subject such as a flower in the awaking.
- 3 Indented work-sampling shooting**
It is giving pauses on the way of work-sampling. The pauses are fixed in the above operation, but in this method you can add the pausing. This method is applied with a Time Lapse Programmer (under development).

- ◀ Ordinary Interval
- Indented Interval

■ Self-Timer E

Self-timer shooting can be performed with the timer inserted into the remote control socket. Shooting continues for ten seconds after 10-second interval.

Notice

- When you shoot with your eyes off the eyepiece, as in remote control operation, tilting, or panning on a tripod, be sure to put the viewfinder cover on the eyepiece to prevent light from coming through the eyepiece, the eyepiece.
- When the camera is not used for a long time, take out the camera from the carrying cover and keep it in a place safe from dust and moisture. Do not store the camera near chemicals such as naphthaline. Be sure to keep the batteries removed. It is better for a camera to be used at times rather than to be stored for a long time.
- Blow off the any dust on the lens with a blower brush or with a soft brush. If accidentally fingerprints are printed on the lens, wipe them off softly with silicone cloth. Do not wipe strongly, or the lens may be injured.
- If the camera is dropped in sea water, usually it is impossible to be repaired almost in any case. In such a case, ask at a service station.
- When carrying the camera or when storing it, be sure to keep the switch dial at "OFF".
- High temperatures are very harmful to a camera such as inside the rear window or the trunk of automobiles.
- When in use, it is convenient to carry as shown in the photo. When the camera is not used, fold the grip and put the camera into the carrying case.



Type	Focal Length	Distance Scale	Distance from Film Plane to Subject	Picture Area
58mm Close-Up Lens 450	7.5mm	∞	609mm (2')	339 x 251mm (1'11-3/8" x 9-7/8")
		1.2mm (4')	475mm (1'6-3/4")	224 x 166mm (8-7/8" x 6-9/16")
	60mm	∞	609mm (2')	45 x 33mm (1-3/4" x 1-5/16")
		1.2mm (4')	475mm (1'6-3/4")	30 x 22mm (1-3/16" x 7/8")
58mm Close-Up Lens 240	7.5mm	∞	394mm (1'3-1/2")	179 x 132mm (7-1/16" x 5-1/4")
		1.2m (4')	353mm (1'1-7/8")	138 x 102mm (6-7/16" x 4-1/16")
	60mm	∞	394mm (1'3-1/2")	24 x 17mm (15/16" x 11/16")
		1.2m (4')	353mm (1'1-7/8")	18 x 13mm (3/4" x 1/2")

Accessories

Close-Up Lenses C-8 (exclusive for 8mm movie cameras)

The Canon Close-Up Lenses C-8 exclusive for 8mm movie cameras are used for obtaining the zooming effect in close-up shooting. When attaching it on the lens tip, you can enjoy zooming in the world of close-up by a simple turn of the zooming ring. Providing complete compensation for chromatic aberration, it expands the range of movie making such as titling, copy work, shooting flowers or insects. You can, of course, observe the changing

Type	Filter Characteristics
● UV	Absorbs only ultra-violet rays. Especially effective at seaside and high mountains. Recommended for use of color film.
○ Y1 ○ Y3	Increases contrast of monochrome film. Enhances clouds, darkening the blue sky. Brightens red and yellow.
○ O1	Darkens blue, increases yellow and red perceptibly. Good for contrasts, especially in distant landscapes.
○ R1	Makes strong contrasts. May also be used with infrared film.
○ G1	Prevents red from turning radically into white. Lightens faces and sky appropriately, and reflects the lightness of fresh greenery.
● ND4 ● ND8	ND4 reduces light volume by 1/4, NDB by 1/8. No effects on the reproduction of colors of color film.
● SKY-LIGHT	Acts to harmonize the blue sky and shade.
● CCA 4	For use with daylight type film under the cloud.
● CCA 8	For use with tungsten type film under the morning sun or sunset.
● CCB 4	For use with daylight type film under the morning sun or sunset.
● CCB	For use with daylight type film under tungsten light. (12equiv.)
○	For black and white film. ● For color film.

angle-of-view through the viewfinder, because the Auto Zoom 814 Electronic incorporates the SLR type viewfinder (with no parallax).

- Two close-up lenses are available: The 58mm Close-Up Lens 450 C-8, and the 58mm Close-Up Lens 240 C-8. "58mm" indicates the filters' outer diameter in millimeters. When the distance scale is set at infinity, "450" and "240" indicate that the subject at a distance of 450mm and 240mm, respectively, from the lens face, are in focus.

Filters

The Canon Auto Zoom 814 Electronic uses the TTL light metering system, which measures the light through-the-lens. Therefore, when the filter is attached, compensation for exposure is not required. Choose the filter according to the shooting purpose. The filter size is 58mm, outer diameter.

Copy Stand 4

Used for titling, close-up shooting, copy work and single frame shooting. Consists of stanchion, carrying arm, metal fasteners and case.



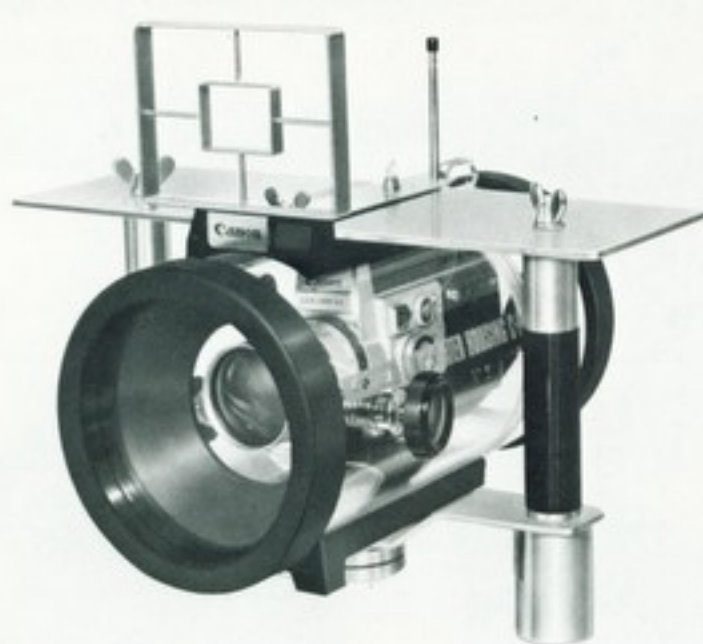

Canon Underwater Housing C-8

Canon Underwater Housing C-8 is a special accessory of 8mm cine camera for underwater shooting.

This housing is designed to resist water pressure up to depths of 20 meters (67 feet) during 30 minutes. Besides, its ease of operation and durability are remarkable.

The housing is built so as to stay in a given position and its operational sections are arranged in the most convenient way to ensure stable underwater shooting.



Canon Cine Projector S-400

Canon Cine Projector S-400 is a high quality movie projector. It can automatically load and rewind all 8mm film—Super 8, Single 8 and regular 8mm film up to 400 feet. Operation is very simple. Just insert the film end into the projector, turn the switch, and the film will run completely through and rewind with no need for resetting or touching any other switches. The Cine Projector S-400 has a fast 17-28mm F1.3 zoom lens, 8v 50w mirror lamp, adjustable projecting speeds including slow motion. This projector can be used in any country as it has a choice of seven different voltages from 100 to 240 V.

Size : 333 x 169 x 155mm (1'1-1/8" x 6-5/8" x 6-1/8")

Weight : 5.2 kg (11 lbs. 7-3/8 ozs.)

Technical Data

Type : 8mm movie camera with easy-loading system using Super 8 film cartridge.

Frame Size : 5.8 x 4.2mm.

Projected Picture : 5.4 x 4.0mm.

Lens : F1.4 with focal length of 7.5mm - 60mm. Zooming ratio 1 : 8, 19 element in 13 component including 11 rare glasses. Coated in Spectra-Coating. Inner diameter, 58mm. Outer diameter, 60mm.

Viewfinder : Single-lens reflex type combined with prism screen range finder. Meter informations (diaphragm scale, meter needle, over/under-exposure warning mark) and film-end signal built-in. Eyepiece is adjustable (-3 to +2 diopter), with Eyecup.

EE Mechanism : TTL type Servo EE Mechanism with CdS photocell controlling diaphragm, coupled to film speed and filming speed.

Light Measuring Range : From ASA 400, f/1.4, 18 fps, shutter angle "OPEN", to ASA 16, f/32, slow-motion, shutter angle "4".

Film Speed : Automatically set by inserting the film cartridge.

Artificial Light Type : ASA 25, 40, 64, 100, 160, 250, 400

Daylight Type : ASA 16, 25, 40, 64, 100, 160, 250

CCA Filter : Color Conversion A (CCA) filter built-in for using artificial light type film in daylight. Cancelled by inserting CCA Filter Cancellation Adapter or lighting unit to CCA Filter Cancellation Adapter Socket. Automatically removed by inserting the daylight type cartridge.

Filming Speed : 18 fps, 24 fps, single-frame and instant slow-motion (about 40 fps).

Variable Shutter Control : 0°-150°, continuously. Fadings are possible with this mechanism.

Manual Aperture Control : Possible with EE/Manual Aperture Control Ring.

Power System : Automatic filming and zooming by precise micromotors.

Power Source : Four 1.5 V penlight (AA size) batteries, contained in handgrip. Powers filming system, zooming system and exposure meter.

Zooming Speed : About 7-8 sec. (entire range).

Manual Zooming : With zooming ring, rotation angle about 120°.

Running Ability : About 10 cartridges at general speed in normal temperature with new batteries. Single-frame in normal temperature with new batteries approx. one cartridge.

Footage Counter : Counts exposed footage. Automatically resets by removing the cartridge.

Frame Counter : 72 frames in one rotation (1 ft), 2 frames per scale. With adjustable indication mark.

Battery Check : Check button and check window.

Handgrip : Folding type, containing battery chamber.

Sockets : For remote control, and for flash synchronized to single-frame shooting.

Remote Control : Possible with Remote Switch 60 or Remote Switch 3.

Switch Dial : Safety switch, with running lock.

Film-End Caution : Orange warning lamp, lights up in the viewfinder 2.5 ft before film-end.

Safety Devices : EE warning marks, shutter lock, film transport indicator.

Macro-Shooting System : By setting with the macro-set lever. With the focusing distance at infinity, possible to get near to subject 16.5cm (6.5") from film plane indicator, picture area 33mm x 45mm.

Unmanned Time Control and Interval Shooting : Memo-motion, work sampling and indented work sampling are possible with Interval Timer E or Time Lapse Programmer.

Accessories : Lens Hood W-60, 58mm Filter, 58mm Close-Up Lens 450, 240 C-8, Remote Switch 60, Remote Switch 3, Lens Cap, Viewfinder Cap, CCA Filter Cancellation Adapter, CCA Filter Cancellation Adapter Socket Cover, Cine Projector S-400, *Time Lapse Programmer, Interval Timer E, Self-Timer E, *Flash Unit Attachment Adapter, Underwater Housing C-8, *Wireless Remote Control. (*These accessories will be marketed soon.)

Size : 224 x 118 x 70mm (8-13/16" x 4-5/8" x 2-3/4")

Weight : 1,550 g (3 lb. 6-11/16 OZ.).

Subject to alterations.

