

8

# Canon E250

8mm VIDEO CAMCORDER

Instruction Manual

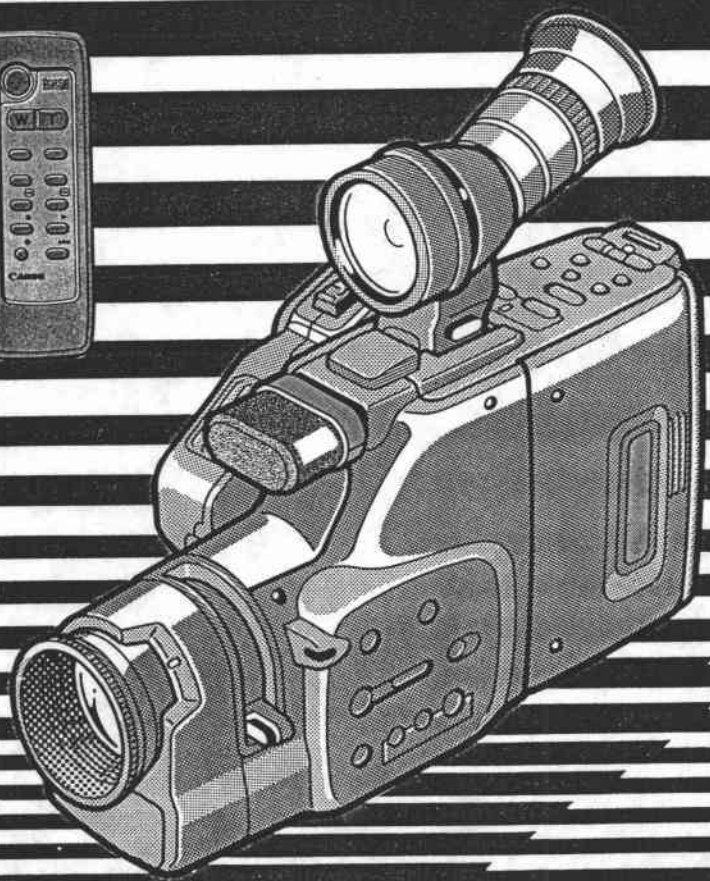

INSTRUCTIONS  
B3P. ENG



C3/19-168



E 250

## Troubleshooting Message

Use the following checklist for troubleshooting when you have problems with your camcorder. See instruction manual for further information.

### Warnings that appear in viewfinder:

- **Battery pack charge is low.**
  - ⇒ Replace with fully charged battery pack.
- **Video cassette is not loaded.**
  - ⇒ Load a video cassette.
- **Erasur prevention switch on the video cassette is set to "SAVE".**
  - ⇒ Use another video cassette or set switch to "REC".
- **Condensation has formed inside unit.**
  - ⇒ Refer to instruction manual.
- **Safety mechanism is activated.**
  - ⇒ Unload and reload video cassette.
- **Lithium battery is not in place properly or charge is low.**
  - ⇒ Insert new lithium battery.

# Canon E250 Quick Reference Guide

## Before Using Camcorder

### Charging Battery Pack

Make sure the battery pack is fully charged before using.

1. Connect battery pack to CA-100.
2. Plug into mains outlet. When battery pack is fully charged, the charge indicator glows steadily.

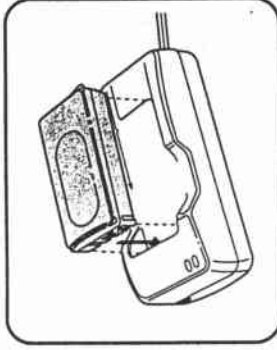

### Attaching Battery Pack

1. Slide battery pack into power source compartment. Slightly loosen grip belt and press it down for easy battery loading.
2. Press battery pack until it clicks and locks in place.

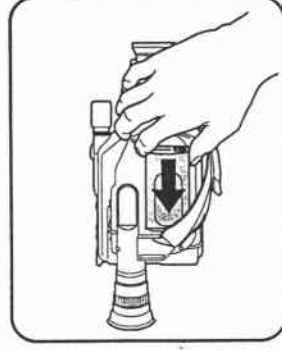

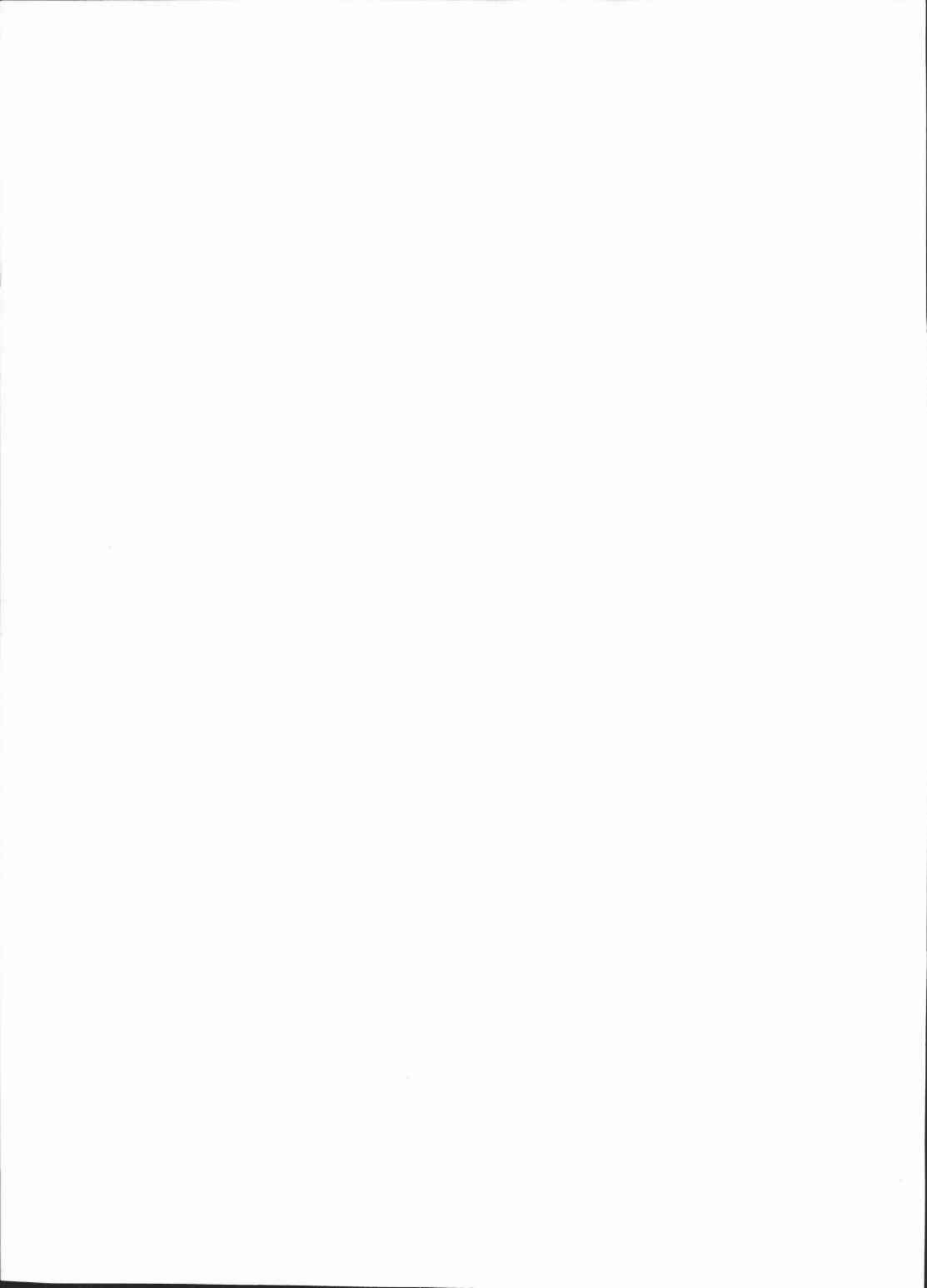

# Recording

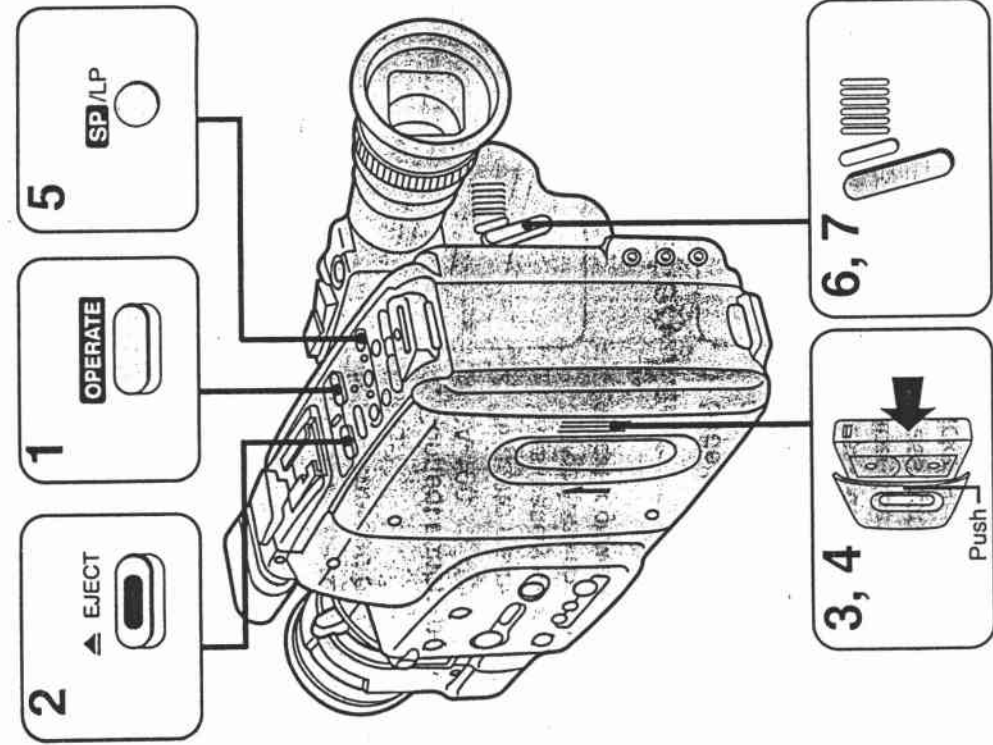

Before recording, make sure a power source is attached to camcorder.

1. Press **OPERATE** button to turn camera on.
2. Press **EJECT** button to open video cassette compartment.
3. Load video cassette.
4. Close video cassette compartment.
5. Press **SP/LP** button to select speed.
6. Press start/stop button to start recording.  
Tally lamp flashes rapidly and "REC" appears in viewfinder.
7. Press start/stop button to place camera in record pause mode.

### To continue recording

- Press start/stop button again.

### To end operation

- Unload video cassette and turn camera off.



# Advice for Shooting

High-Angle Shooting

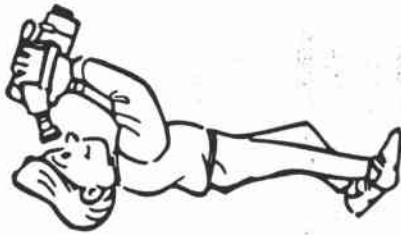

Low-Angle Shooting



Standing Shooting



Half-Sitting Shooting







# Playback

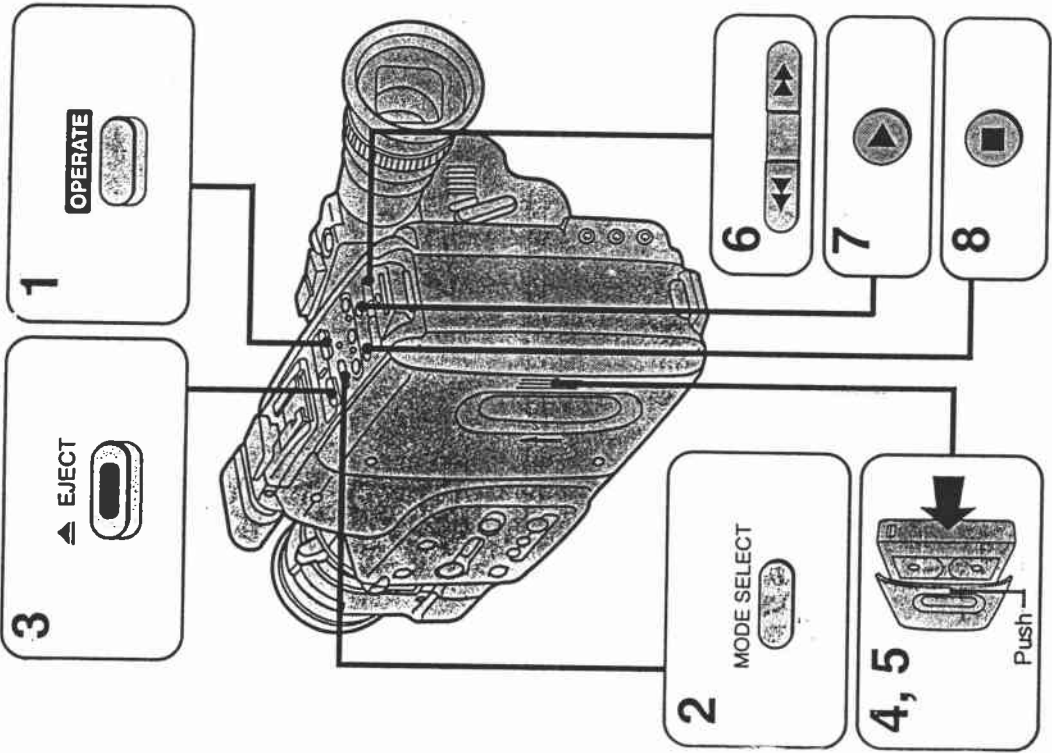

Before playback, make sure a power source is attached to camcorder (CA-100 with DC-100 or battery pack).

1. Press **OPERATE** button to turn camera on.
2. Press **MODE SELECT** button to select **PLAY** mode.  
Mode indicator changes from red to green.
3. Press **EJECT** button to open video cassette compartment.
4. Load video cassette.
5. Close video cassette compartment.
6. Locate playback start point using **▶▶** (FF) or **◀◀** (REW) buttons.
7. Press **▶** (PLAY) button to start playback.  
If a television is connected to camcorder, you can also monitor playback on the connected television.
8. Press **■** (STOP) button to end playback.

## About PLAY Mode

Press **MODE SELECT** button once to select the **PLAY** mode. Mode indicator lights up green. In **PLAY** mode, the four buttons on the top of the camcorder have the function indicated in blue. Use these buttons or the wireless controller to playback a video cassette.

### To change to CAMERA mode

- Press **MODE SELECT** button again.  
Mode indicator changes from green to red and the camcorder is put in record pause mode.
- To end operation**
  - Unload video cassette and turn camcorder off.



Thank you for purchasing the Canon 8mm Video Camcorder E250. The E250 can be used for both recording and playback of video cassettes in 8mm format.

- Use 8mm video cassettes marked with an **8** (P5 type).
- With the E250, stereo recording is possible. However, tapes recorded in stereo will play back on monaural 8mm VTRs in monaural.

Please check that this package contains the following items:

E250	Lens Cap and Lens Cap Cord	VL-7 Battery Video Light
	Lens Hood	DC-100 DC Coupler
	SF-200 Sports Finder	BP-E77K Battery Pack
	One Lithium Battery	CA-100 Compact Power Adapter
	WL-50 Wireless Controller	ST-250 Stereo Cable
	Two R03 / AAA Batteries	RU-100 RF Unit
		SS-300 Shoulder Strap

#### Optional Accessories

BP-E722 Battery Pack	FS-37U Filter Set
CB-110 Car Battery Adapter	C-150 AV Cable
MC-100 Multi-battery Charger	PC-150 SCART Cable
SC-800 Soft Carrying Case	PC-370ST Stereo SCART Cable
HC-60 System Case	WS-20 Wrist Strap
RS-60 Rain Shield	MM-200 Stereo Mixing Microphone
VL-20 Battery Video Light	ZM-100 Stereo/Zoom Microphone
TL-37 Tele-converter	MB-100 Microphone Boom
WD-37 Wide-converter	SA-1 Adapter Bracket
FS-37 Filter Set	

## Important Usage Instructions

### CAUTION:

**TO REDUCE THE RISK OF ELECTRIC SHOCK, DO NOT REMOVE COVER (OR BACK). NO USER SERVICEABLE PARTS INSIDE. REFER SERVICING TO QUALIFIED SERVICE PERSONNEL.**

### WARNING:

**TO REDUCE THE RISK OF FIRE OR ELECTRIC SHOCK, DO NOT EXPOSE THIS PRODUCT TO RAIN OR MOISTURE.**

### CAUTION:

**TO REDUCE THE RISK OF ELECTRIC SHOCK AND TO REDUCE ANNOYING INTERFERENCE, USE THE RECOMMENDED ACCESSORIES ONLY.**

# Table of Contents

Important Usage Instructions .....	3
------------------------------------	---

## BEFORE USING

Camera Parts and Functions .....	6
WL-50 Wireless Controller .....	10
CAMERA and PLAY Modes .....	12
Viewfinder Displays .....	14
Power Sources .....	15
Using Battery Pack .....	15
Using AC Power .....	18
Using Car Battery .....	18
Inserting New Lithium Battery .....	20
Setting Date and Time .....	21
Camera Preparations .....	25
Attaching Strap .....	25
Attaching Lens Cap Cord .....	26
Removing and Attaching Lens Cap and Lens Hood .....	26
Adjusting Grip Belt .....	26
Adjusting Diopter .....	27
Adjusting 180° FlexiGrip with Integral Electronic Viewfinder .....	27
Sports Finder .....	27

## RECORDING (CAMERA Mode)

Camera Recording .....	28
Video Cassette Notes .....	30
Tape Counter .....	31
Recording Reminder .....	31
Video Cassette Warning .....	32
Battery Pack Warning .....	32
About Backlighting .....	32
Recording Using Tripod .....	32
Record Search (Assembly Editing) .....	33
Record Review .....	34
Recording Date and Time .....	36
Focusing .....	37
Autofocus .....	37
Manual Focus .....	39
Focus Lock .....	39
Macro Recording .....	40
Zooming .....	41
Power Zoom .....	41
Manual Zoom .....	41
Wireless Zoom .....	41
White Balance .....	42
What is White Balance? .....	42
Auto White Balance .....	42
Subjects Not Suitable for Auto White Balance .....	42
White Balance Lock .....	42
White Balance Lock Procedure .....	43

<b>Shooting with Video Light</b> .....	44	
Attaching Video Light .....	44	
Removing Video Light .....	44	
Shooting with Video Light .....	45	
Replacing Bulb .....	46	
<b>Gain-up</b> .....	48	
<b>High-speed Shutter</b> .....	49	
<b>Fade</b> .....	50	
Fade In .....	50	
Fade Out .....	51	
Wireless Fade .....	52	
<b>Timer Recording</b> .....	53	
<b>Adding Titles to Recordings</b> .....	56	
Creating Character Titles .....	56	
Scrolling Character Titles .....	59	
Creating Digital Titles .....	61	
Recording Titles .....	62	
<b>Using External Microphone and Headphones</b> .....	64	
Using External Microphone .....	64	
Using Headphones .....	64	
<b>PLAYBACK (PLAY Mode)</b>		
<b>Playback Connection</b> .....	65	
Using TV with Audio / Video Input Terminals .....	65	
Using TV with SCART Terminal .....	66	
Using TV without Audio / Video Input Terminals (European Model) .....	67	
Using TV without Audio / Video Input Terminals (Australian Model) .....	69	
<b>Playback Procedure</b> .....	71	
<b>Special Playback Methods</b> .....	73	
<b>Tape Return</b> .....	76	
<b>EDITING</b>		
<b>Editing to Another VTR</b> .....	77	
Adding Titles .....	78	
<b>ADDITIONAL INFORMATION</b>		
<b>Canon E250 Video System Chart</b> .....	80	
<b>Carrying Cases</b> .....	81	
<b>Optional Accessories</b> .....	82	
<b>Problems and Troubleshooting</b> .....	84	
<b>Condensation (DEW)</b> .....	87	
<b>Cautions</b> .....	88	
During Use .....	88	
Using Your Battery Packs Effectively .....	90	
Maintenance .....	92	
<b>Specifications</b> .....	93	

BEFORE USING

RECORDING

PLAYBACK

EDITING

ADDITIONAL INFORMATION

# Camera Parts and Functions

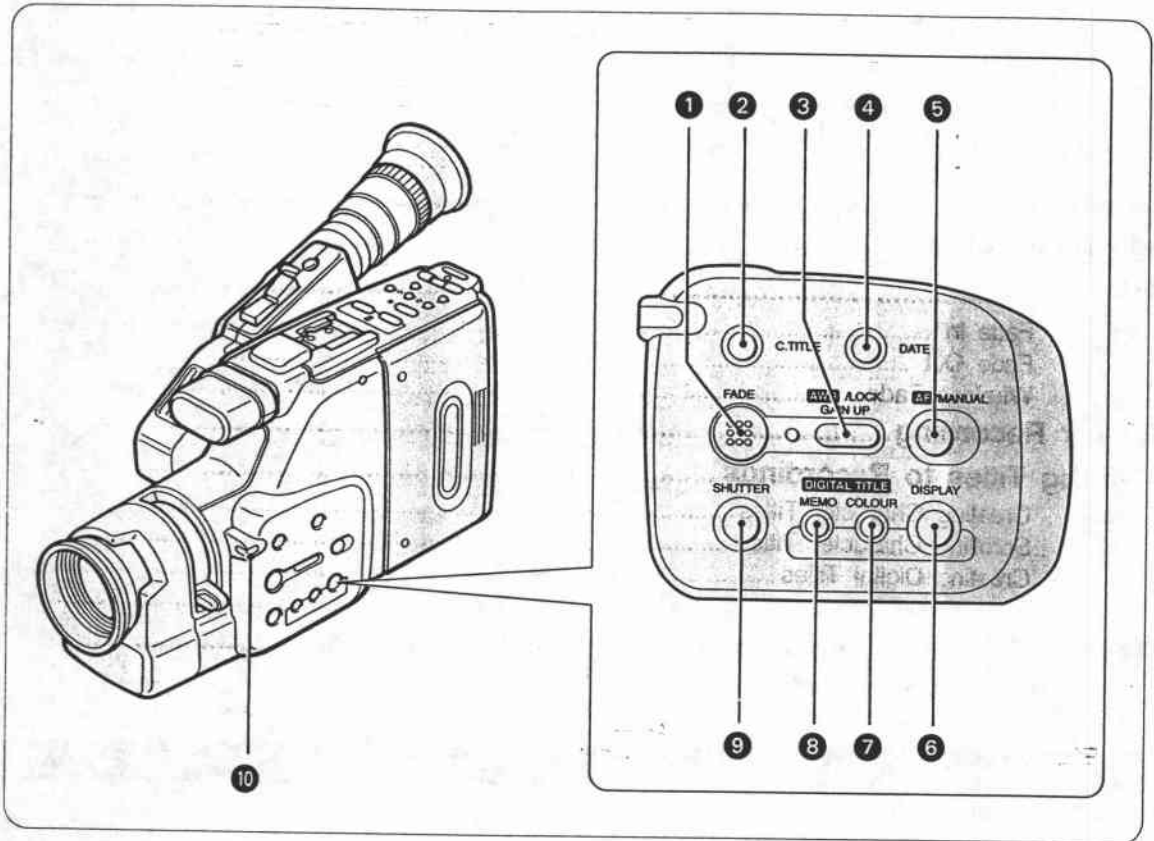

- ① FADE Button
- ② C. (Character) TITLE Button
- ③ AWB (Auto White Balance)/LOCK/  
GAIN UP Button
- ④ DATE Button
- ⑤ AF (Autofocus)/MANUAL Button

## DIGITAL TITLE

- ⑥ DISPLAY Button
- ⑦ COLOUR Button
- ⑧ MEMO (Memory) Button

- ⑨ SHUTTER Button
- ⑩ Tally Lamp

The tally lamp performs four important functions:

- Flashes rapidly during recording.
- Flashes slowly during self-timer standby and then starts flashing rapidly when recording starts.
- Flashes slowly when interval timer is set.
- Lights up when wireless controller is in use.

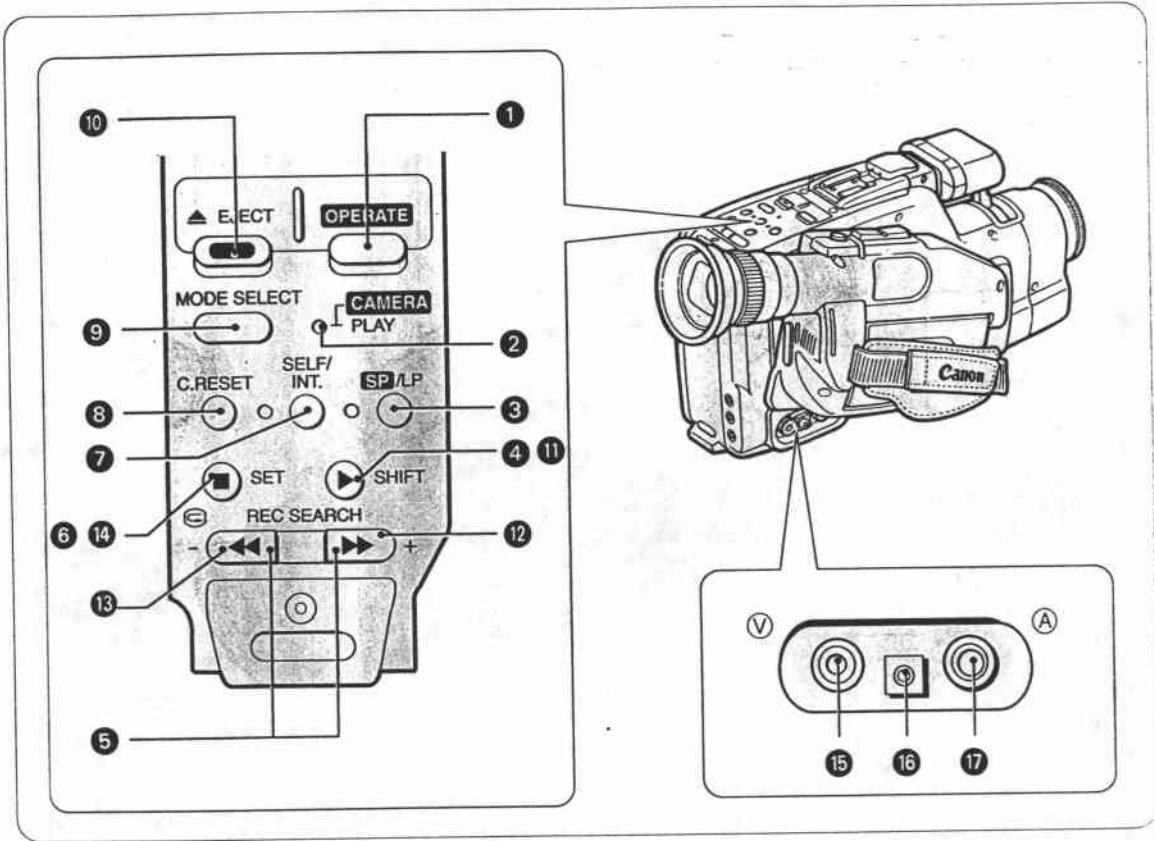

- ① **OPERATE** Button
- ② **Mode Indicator**  
The mode indicator lights up (red in CAMERA mode, green in PLAY mode) during normal operation, and flashes to warn that there is internal condensation, a malfunction, or to indicate that the battery pack needs to be recharged.
- ③ **SP/LP** (Tape Speed Select) Button
- ④ **SHIFT** Button
- ⑤ **REC SEARCH +/-** Buttons  
⏮ (Record Review) Button
- ⑥ **SET** Button
- ⑦ **SELF/INT.** (Interval) Button
- ⑧ **C.** (Counter) **RESET** Button
- ⑨ **MODE SELECT** Button
- ⑩ **EJECT** Button

### PLAY Mode

- ⑪ **▶** (PLAY) Button
- ⑫ **▶▶** (FF) Button
- ⑬ **◀◀** (REW) Button
- ⑭ **■** (STOP) Button
- ⑮ **Video Output Terminal**
- ⑯ **DC Output Terminal**
- ⑰ **Audio Output Terminal**

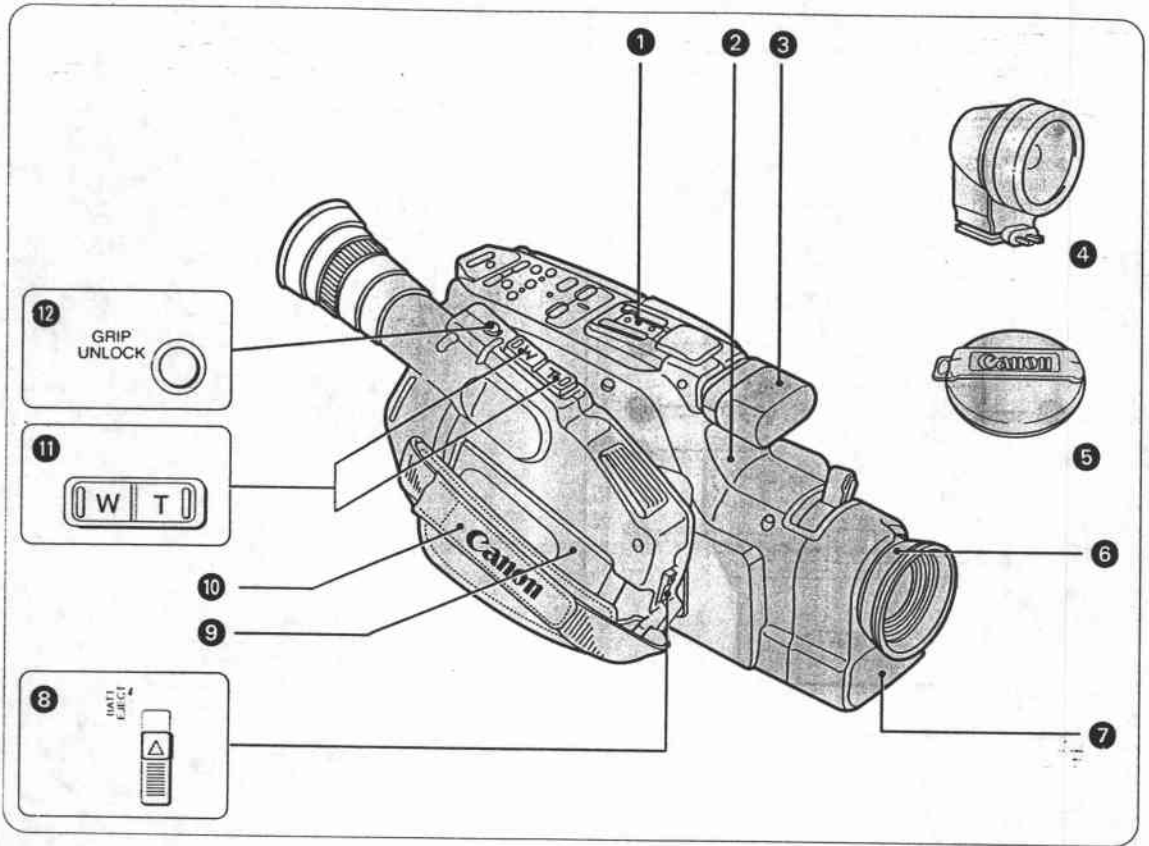

- |   |  |
|---|--|
| <ul style="list-style-type: none"> <li>① Accessory Shoe</li> <li>② Remote Sensor</li> <li>③ Microphone</li> <li>④ Video Light</li> <li>⑤ Lens Cap</li> <li>⑥ Focusing Ring / Lens Hood</li> </ul> | <ul style="list-style-type: none"> <li>⑦ Autofocus Window</li> <li>⑧ BATT (Battery) EJECT Switch</li> <li>⑨ Power Source Compartment</li> <li>⑩ Grip Belt</li> <li>⑪ Power Zoom Buttons</li> <li>⑫ GRIP UNLOCK Button</li> </ul> |
|---|--|



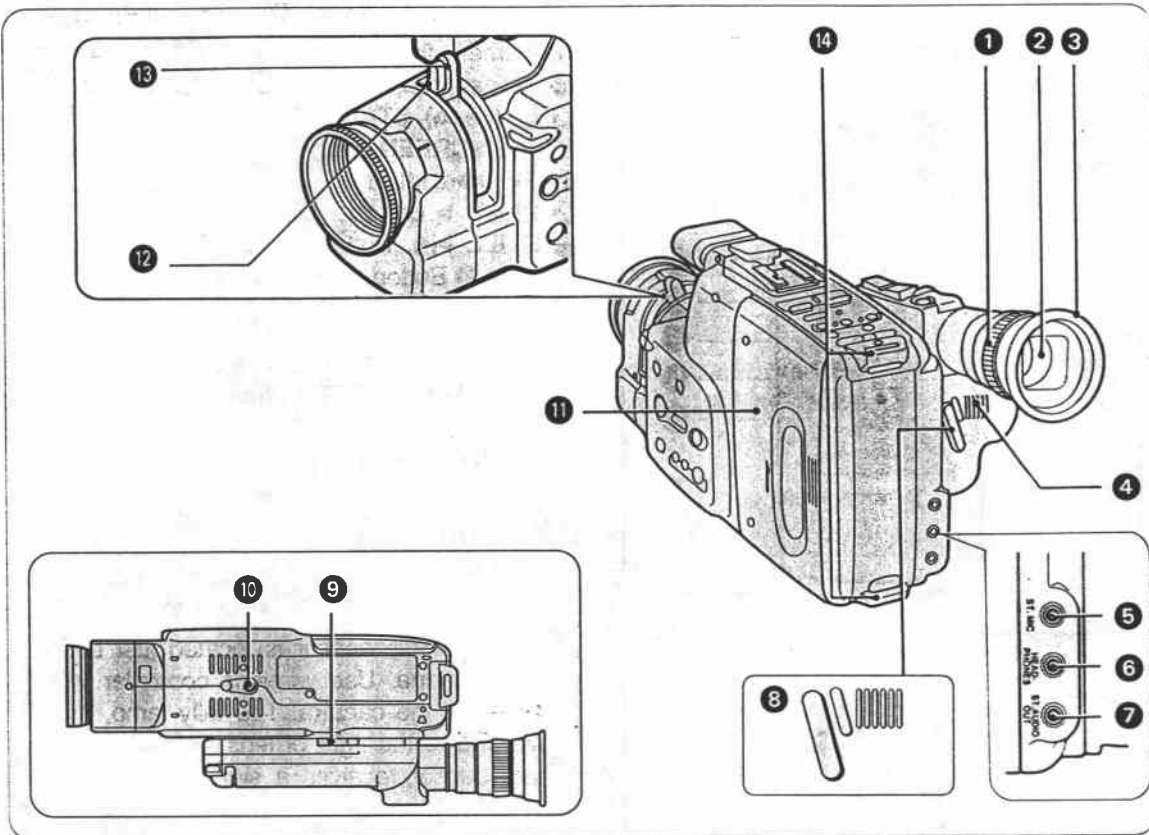

- ① Diopter Adjustment Ring
- ② Viewfinder
- ③ Eyecup
- ④ Thumb Rest  
Place your thumb here when you are recording or carrying the camera.
- ⑤ ST. (Stereo) MIC Terminal
- ⑥ HEADPHONES Terminal
- ⑦ ST. (Stereo) AUDIO OUT Terminal
- ⑧ Start/stop Button
- ⑨ Lithium Battery Compartment
- ⑩ Tripod Socket
- ⑪ Video Cassette Compartment
- ⑫ Macro Button
- ⑬ Zooming Lever
- ⑭ Strap Attachment Bars

# WL-50 Wireless Controller

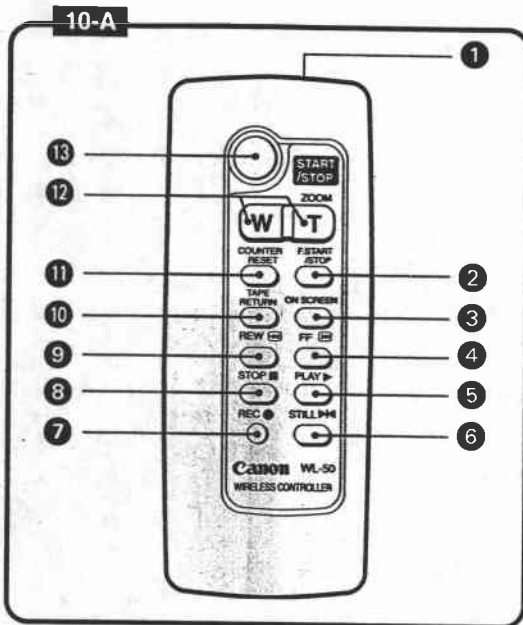

Using the wireless controller you can operate the camera from a distance. **10-A**

- ① Transmitter
- ② F. (Fade) START/STOP Button
- ③ ON SCREEN Button
- ④ FF ►► Button
- ⑤ PLAY ► Button
- ⑥ STILL ◀◀ Button
- ⑦ REC ● Button
- ⑧ STOP ■ Button
- ⑨ REW ◀◀ Button
- ⑩ TAPE RETURN Button
- ⑪ COUNTER RESET Button
- ⑫ ZOOM Buttons
- ⑬ START/STOP Button

## Operation **10-B**

Aim wireless controller at camera remote sensor and press control buttons to operate camera. Remote sensor is located just below the microphone. Use wireless controller within 4 metres of the camera. The tally lamp, located above and to the right of lens, lights up when remote sensor receives a signal.

- ⑭ Remote Sensor
- ⑮ Tally Lamp

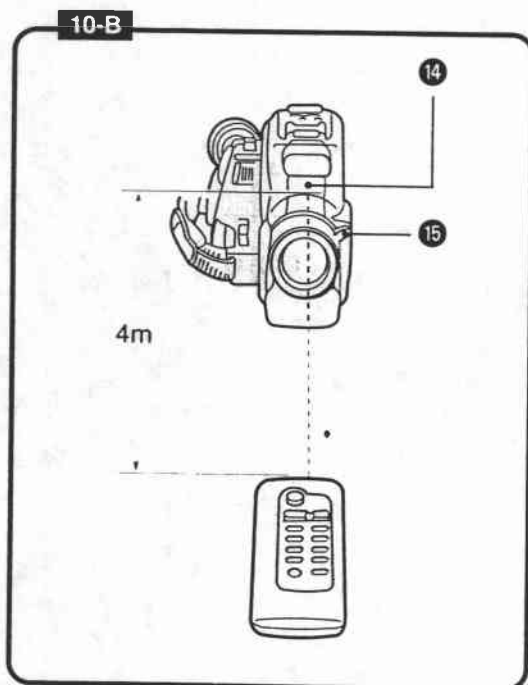

### Notes:

- When using wireless controller, check that it lights up the tally lamp. If tally lamp lights, wireless controller can be used from that position.
- If you are too close to camera when operating wireless controller, camera may not respond to wireless controller's signal.

## Inserting Batteries into Wireless Controller

The wireless controller operates on two R03 / AAA batteries.

1. Remove cover from back by pressing down and sliding in direction of arrow.
2. Insert two R03 / AAA batteries following + and - markings. Be careful not to reverse polarity of batteries.
3. Replace cover following guide grooves.

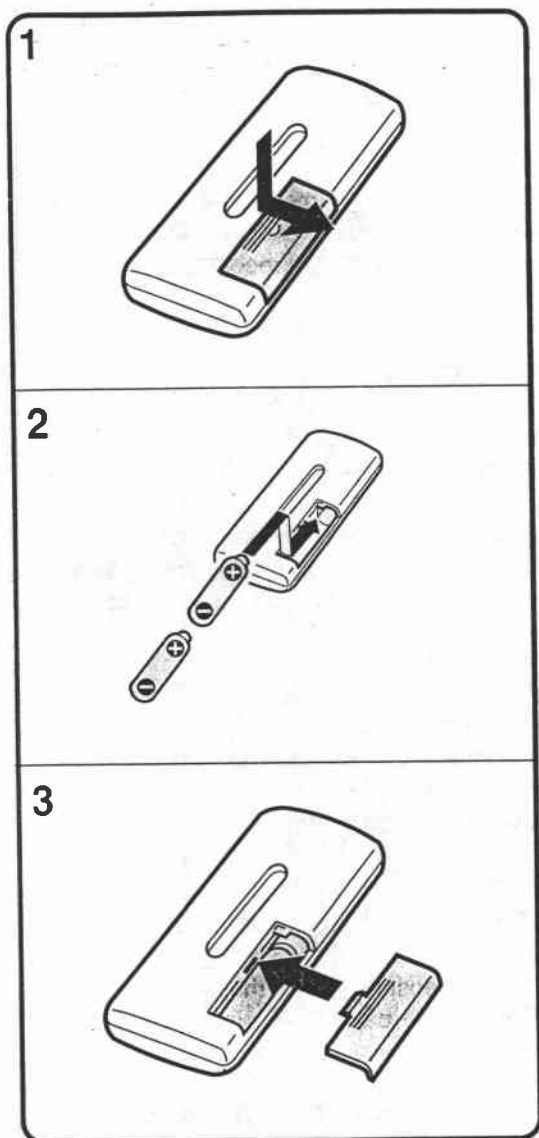

### Notes:

- Do not leave wireless controller exposed to direct sunlight or in hot or humid places.
- Autofocus function stops when remote sensor receives signal from wireless controller.
- Wireless controller uses infrared beams to transmit signals, so sunlight or fluorescent light on the remote sensor may shorten operating distance.
- Wireless controller will not function if RS-60 Rain Shield is attached to the camera.

# CAMERA and PLAY Modes

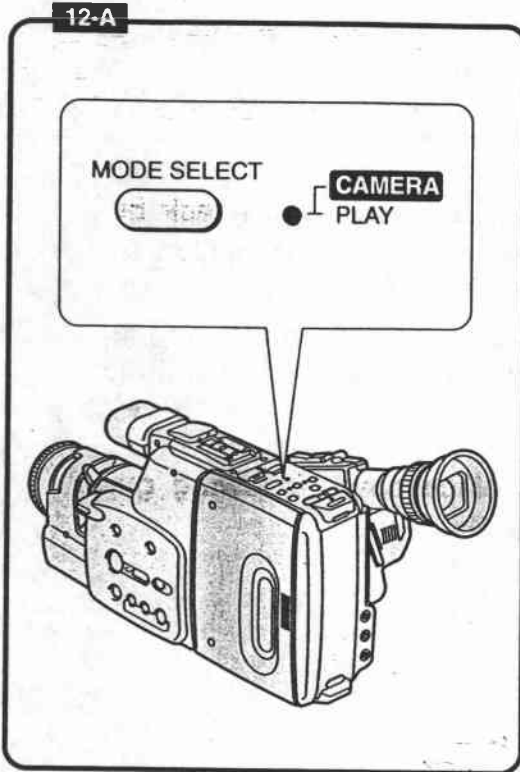

The camera has 2 basic modes of operation: CAMERA mode for recording and PLAY mode for playback. **12-A**

## CAMERA Mode

When you turn the camera on, it automatically enters CAMERA mode and the mode indicator lights up red. Make your recordings in the CAMERA mode.

## PLAY Mode

Press the MODE SELECT button once to select the PLAY mode. Mode indicator will change from red to green. Use the PLAY mode to play back your recordings.

In the PLAY mode the viewfinder and connected TV monitor will appear black, until you press the PLAY button to view recorded scene.

After playback, press the MODE SELECT button again to select the CAMERA mode, or turn the camera off then on again. The mode indicator changes from green to red. You can now make more recordings.

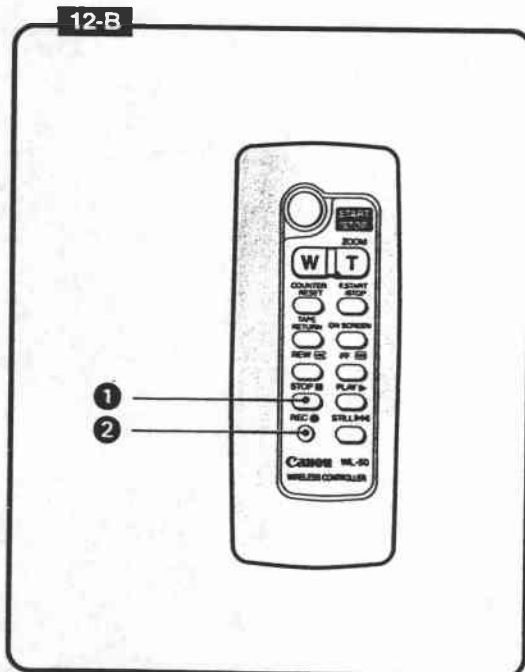

## Mode Indicator

The mode indicator lights up during normal operation, and flashes to warn that there is internal condensation or a malfunction, or to indicate that the battery pack needs to be recharged.

## Changing modes with the wireless controller **12-B**

- In CAMERA mode, press the STOP button **1** to switch to PLAY mode.
- During stop or still playback (in PLAY mode) press the REC button **2** to switch to CAMERA mode.

13-A

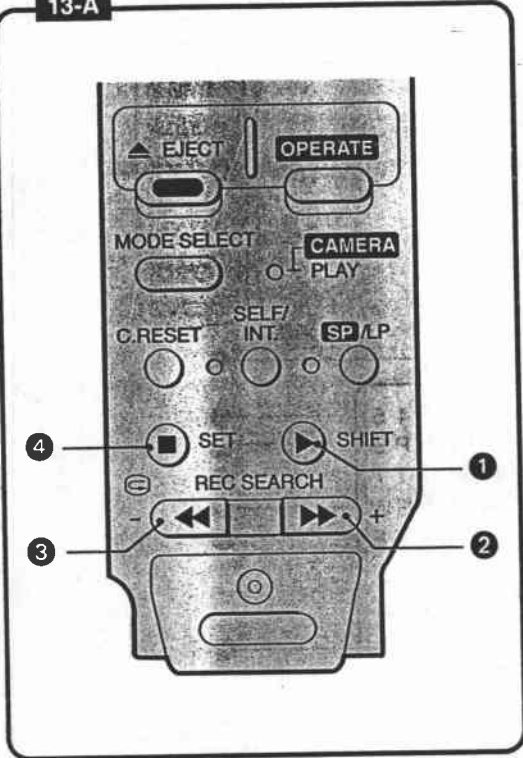

### Dual-mode Buttons 13-A

Dual-mode buttons perform different functions during CAMERA and PLAY modes.

Functions indicated in white are active during CAMERA mode.

Functions indicated in blue are active during PLAY mode.

BEFORE USING

CAMERA mode (white)		PLAY mode (blue)
SHIFT button	①	▶ (PLAY) button
REC SEARCH buttons	+ button	▶▶ (FF) button
	-/⊖ (REC REVIEW) button	◀◀ (REW) button
SET button	④	■ (STOP) button

# Viewfinder Displays

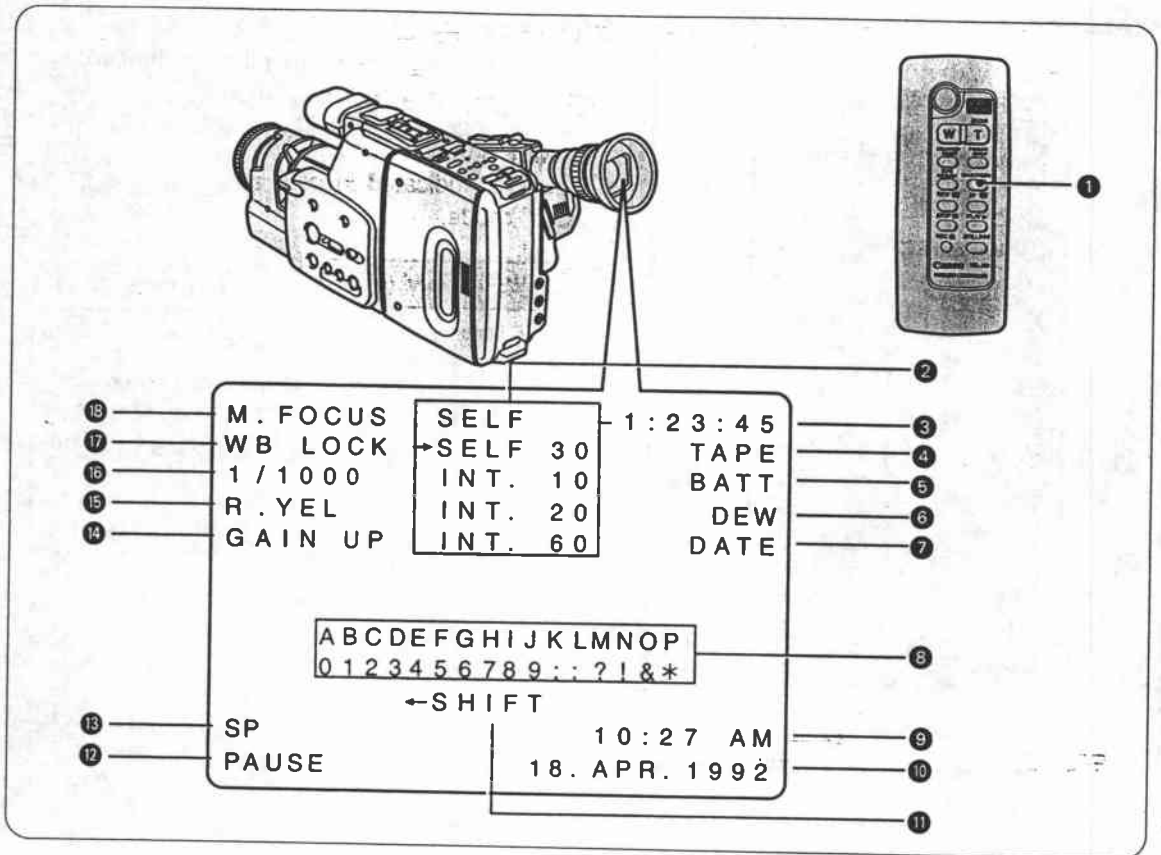

Viewfinder displays provide information and warnings regarding camera operation, recording and playback. Press ON SCREEN button ① on wireless controller to see viewfinder displays except ⑧, ⑨ and ⑩ on a connected TV screen.

- Press C. TITLE button to see character title on TV, DATE button for date and time. Only title, date and time are recorded with scenes.

No.	Mode		No.	Mode	
②	Timer Recording Menu	☞ p. 53	⑩	Date	☞ p. 21, 36
③	Tape Counter	☞ p. 31	⑪	Scrolling Character Title	☞ p. 59
④	Video cassette Warning	☞ p. 32	⑫	Tape Operations	☞ p. 28, 84
⑤	Battery Warning	☞ p. 32, 84	⑬	Tape Speed	☞ p. 28
⑥	Condensation Warning	☞ p. 84	⑭	Gain-up	☞ p. 48
⑦	Lithium Battery Warning	☞ p. 20, 84	⑮	Digital Title	☞ p. 61
⑧	Character Title	☞ p. 56	⑯	High-speed Shutter	☞ p. 49
⑨	Time	☞ p. 21, 36	⑰	White Balance Lock	☞ p. 43
			⑱	Manual Focus	☞ p. 39

# Power Sources

15-A

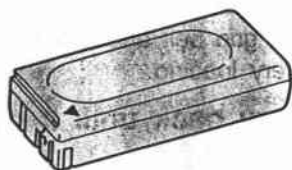

15-B

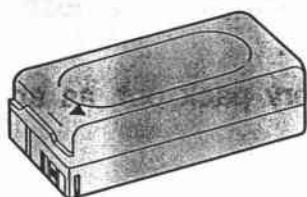

## Using Battery Pack

### BP-E77K **15-A** /BP-E722 (option) **15-B** Battery Pack

Make sure battery pack is fully charged before use.

Continuous recording time of BP-E77K is approximately 45 minutes.

- Some modes consume more power than others, so actual recording time may be less than 45 minutes.
- The safest policy is to have enough batteries to cover two to three times the length of recording time scheduled.
- Using battery pack in cold temperatures will shorten recording time.
- Battery pack normally becomes warm during use.
- Battery's + and - terminals may short circuit if they come in contact with any metal objects. Take care when handling battery pack, and keep it in plastic or other protective covering when carrying or storing.
- Power is slowly drained while the battery pack is attached to the camera, even when the camera is turned off. Remove the battery pack when you don't expect to use the camera.
- Use the optional BP-E722 Battery Pack for lengthy recording (see p. 82).
- See battery pack instruction manual for further information regarding battery pack.
- See p. 90 for Using Your Battery Packs Effectively.
- Canon camcorders and accessories are manufactured with great care and strict quality control. It is recommended that you use only genuine Canon brand batteries and other accessories for your camcorder to ensure maximum performance.

BEFORE USING

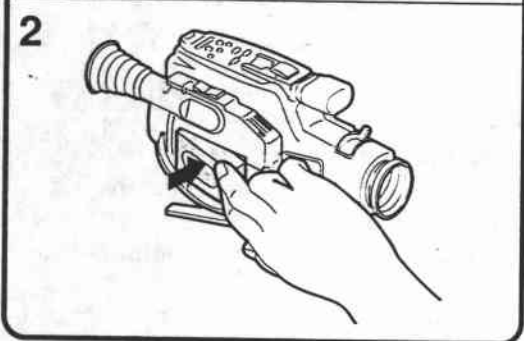
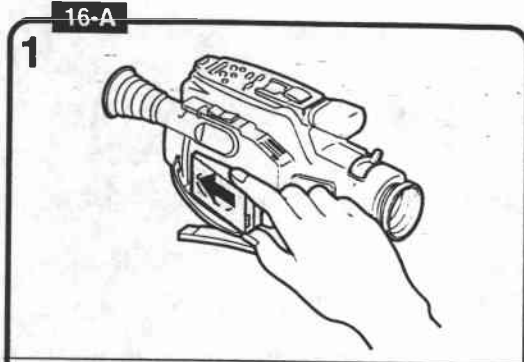

### Attaching Battery Pack 16-A

1. Slide battery pack into power source compartment.
  - Insert the end marked with a triangle.
  - Slightly loosen grip belt and press it down for easy battery loading.
2. Press battery pack until it clicks and locks in place.

### Removing Battery Pack 16-B

**Caution**

Be sure to turn camera off (the mode indicator goes off) before removing battery pack. Removal during operation may cause damage.

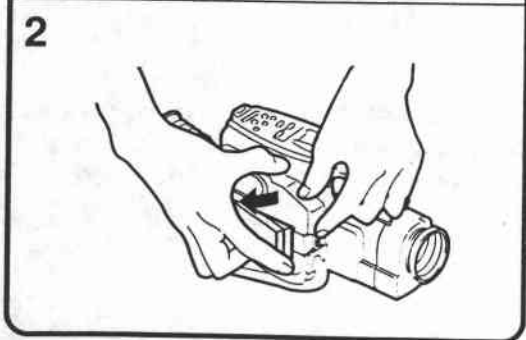
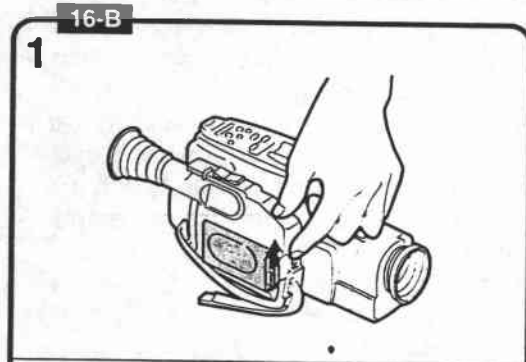

1. Slide and hold BATT EJECT switch up.
2. Pull battery pack out, as shown.



## Charging Battery Pack **17-A**

Use the CA-100 Compact Power Adapter or the optional CB-110 Car Battery Adapter to charge battery pack.

Connect the battery pack to the CA-100 (or CB-110) as shown and plug into mains outlet (or car cigarette lighter socket).

When the operate indicator (green) is glowing steadily and the charge indicator (red) is blinking, charging has begun. When the battery pack is fully charged, the charge indicator will glow steadily. Disconnect the battery pack from CA-100 (or CB-110).

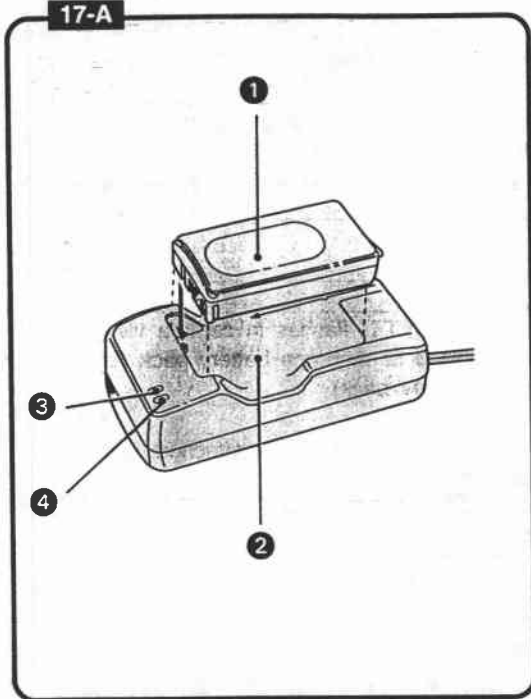

- ① Battery Pack
- ② CA-100 Compact Power Adapter or CB-110 Car Battery Adapter
- ③ Charge Indicator
- ④ Operate Indicator

- Always disconnect the DC-100 DC Coupler from the CA-100 (or CB-110) before charging the battery pack.
- The charging time for one battery pack is shown in the table on the next page. Charging time will vary according to ambient temperature and remaining charge in battery.
- When charging a brand-new battery pack or one that has not been used for three months or more, charge up completely (until the charge indicator lights). Then disconnect and reconnect battery pack to charge once again.
- It is possible to charge battery pack in an ambient temperature range of 0°C – 40°C, but for best results, charge between 10°C – 30°C. Use of battery pack in extremely high temperatures (above 40°C) may activate safety circuit, making operation impossible.
- When you don't expect to use battery pack for a long time (three months or more), **store it in a discharged condition**. Storing the battery pack in a charged condition will shorten its operating life.
- Immediately after use, the battery pack will be hot and it is best not to recharge it at this time. Make sure the battery pack has cooled off before recharging it.
- The optional MC-100 Multi-battery Charger can also be used.

For further information, see the adapter or charger instruction manual.

Battery Pack	Continuous recording time	Charging time
BP-E77K	approx. 45 minutes	approx. 70 minutes
BP-E722	approx. 95 minutes	approx. 130 minutes

### Battery Warning

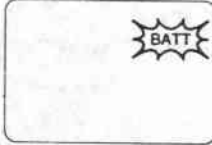

When battery charge is nearly exhausted, "BATT" flashes in camera viewfinder and the mode indicator also flashes. Replace or recharge battery pack (be sure to turn camera off before removing the battery pack).

- If the camera is turned on with an exhausted battery pack attached, it may turn off immediately, without a "BATT" warning.

**18-A**

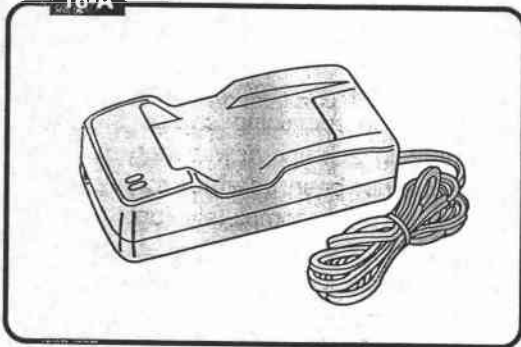

### Using AC Power

#### CA-100 Compact Power Adapter

**18-A**

Plug into mains outlet.

Input voltage: 100—240 V AC, 50/60 Hz.

- Use together with the DC-100 DC Coupler.
- Refer to CA-100 instruction manual for further details.

**18-B**

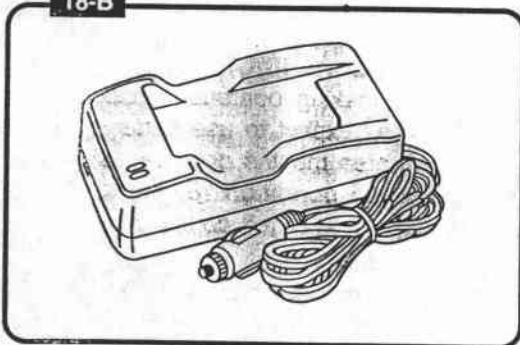

### Using Car Battery

#### CB-110 Car Battery Adapter (option)

**18-B**

Plug into cigarette lighter socket.

For use only with 12 or 24 V DC negative-ground car battery.

- Use together with the DC-100 DC Coupler.
- Use car battery adapter with the car engine idling.
- Refer to CB-110 instruction manual for further details.

**Attaching DC Coupler 19-A**

To use the compact power adapter or car battery adapter:

- 1. Insert DC-100 DC Coupler into power source compartment.**
  - Insert and remove in the same way as the battery pack (see p. 16).
- 2. Connect DC-100 cable to compact power adapter (or car battery adapter).**

**a** DC-100

**b** CA-100 (CB-110)

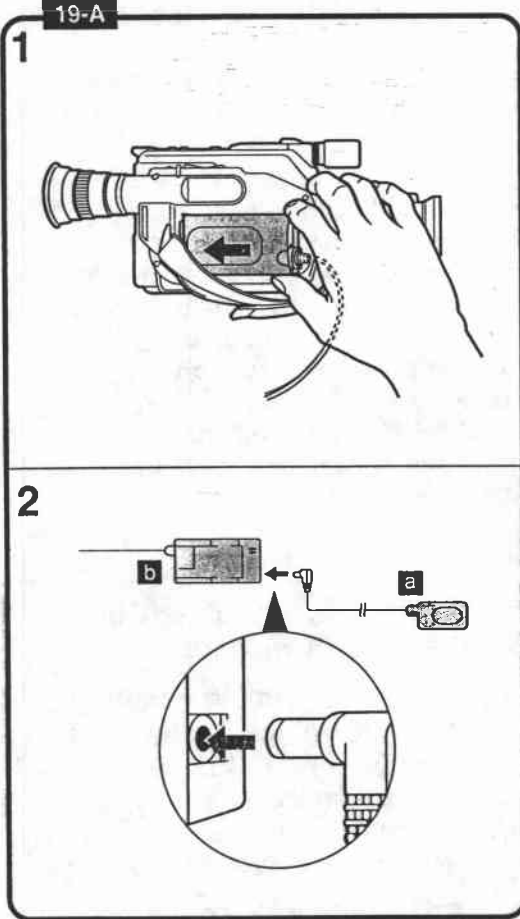
**Caution**

- Using the compact power adapter near the TV may cause the TV to emit noise. If this occurs, move the compact power adapter further away from the TV or aerial cable.

20-A



20-B

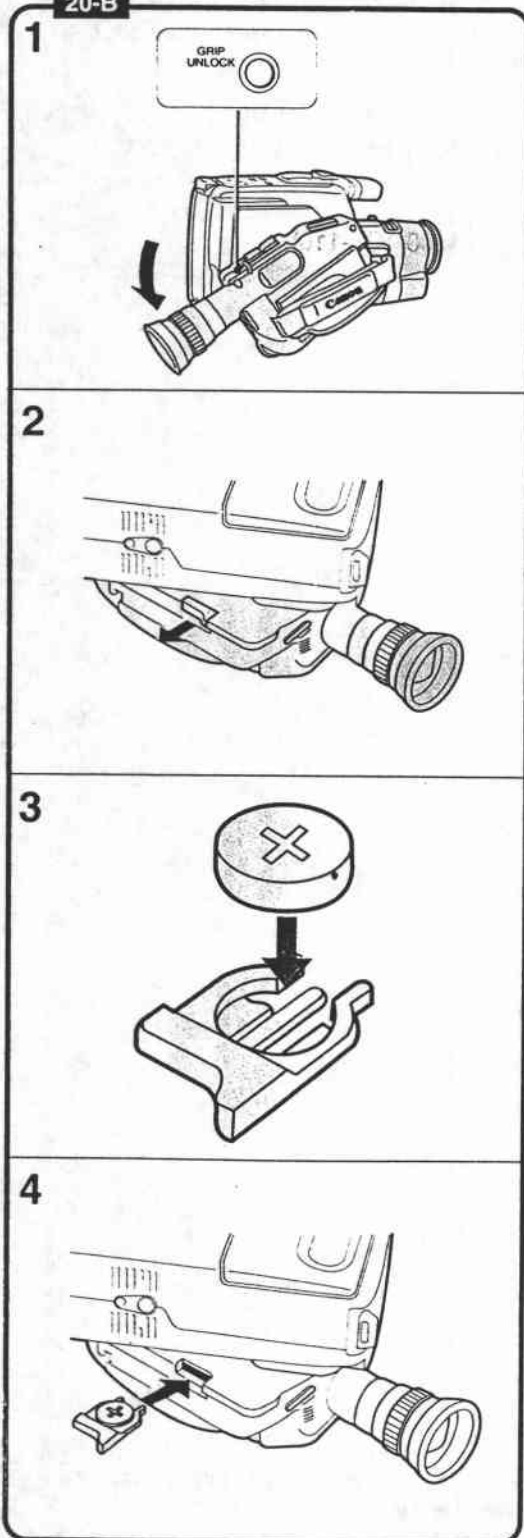

## Inserting New Lithium Battery

The CR2025 type lithium battery provides your camera with enough power to store digital title, date and time settings, even when the camera is turned off.

One lithium battery will last approximately one year. (Life span of lithium battery varies slightly according to ambient conditions.) When lithium battery is not in place or is nearly exhausted, "DATE" flashes in viewfinder, indicating that the lithium battery needs to be replaced. **20-A**

Be sure to connect a power source to the camera before changing the lithium battery, otherwise, digital title, date and time settings will be cleared from camera's memory and will have to be reset.

### Inserting Procedure **20-B**

1. Press **GRIP UNLOCK** button and rotate the grip downward.
2. Hold the camera with the battery pack facing down, then draw out the lithium battery holder.
  - If the camera is held with the battery pack facing up, the lithium battery will drop out when the lithium battery holder is removed.
3. Insert a new lithium battery into the lithium battery holder with **+** side facing up.
4. Snap the lithium battery holder into the compartment.

#### Warning

The battery used in this device may present a fire or chemical burn hazard if mistreated. Do not recharge, disassemble, heat above 100°C or incinerate. Replace battery with Panasonic CR2025 or Duracell DL2025B. Use of another battery may present a risk of fire or explosion. The used battery should be handed back to the supplier.

#### Caution

- Make sure **+** side is facing up in lithium battery compartment.
- Keep battery out of children's reach. If swallowed, contact physician immediately.
- To ensure proper contact, wipe battery with clean, dry cloth before use.
- Do not pick up battery using tweezers or other metal tools which may cause short circuiting.
- Do not disassemble, heat or immerse in water, to avoid risk of explosion.

# Setting Date and Time

BEFORE USING

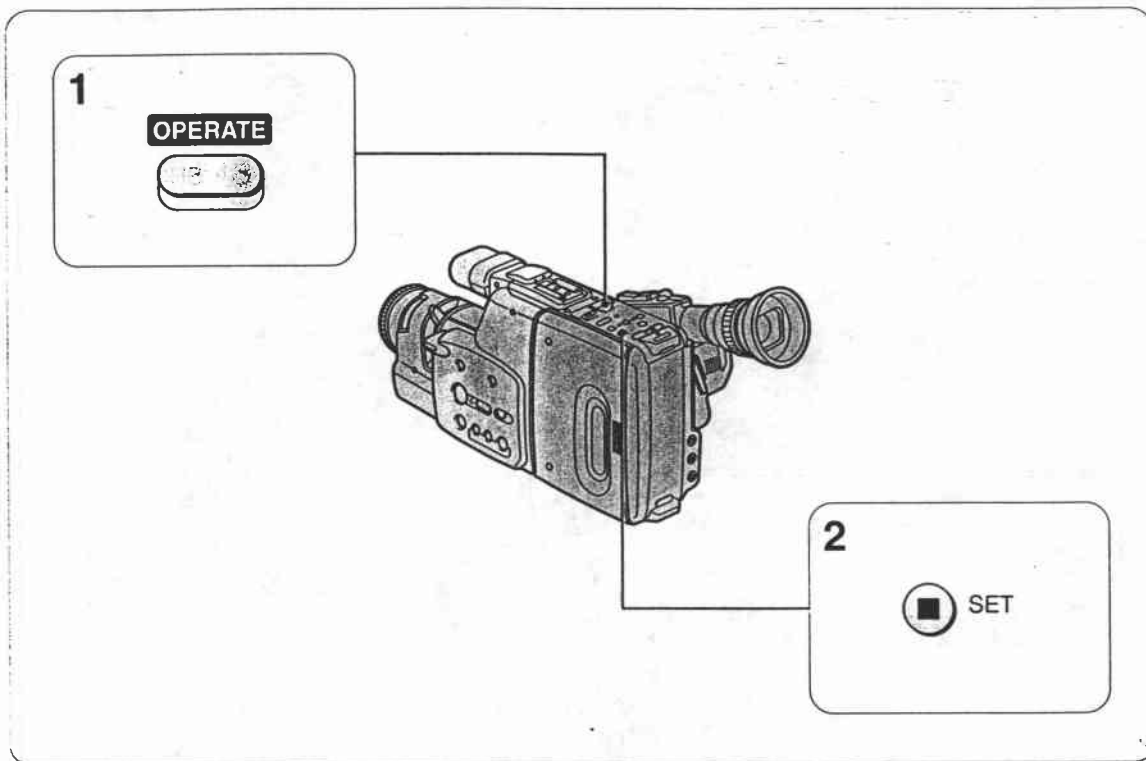

Set date and time when you first begin using the camera and when you change the lithium battery without back-up power. See p. 36 for recording date and time.

Example: Setting date to 20 March, 1993 and time to 2:35 p.m.

- 1. Turn camera on by pressing OPERATE button.**
  - Mode indicator lights up red.
- 2. Press and hold SET button for more than 3 seconds. 21-A**
  - Date and time are displayed in viewfinder.
  - Year display flashes in viewfinder.

(continued on next page)

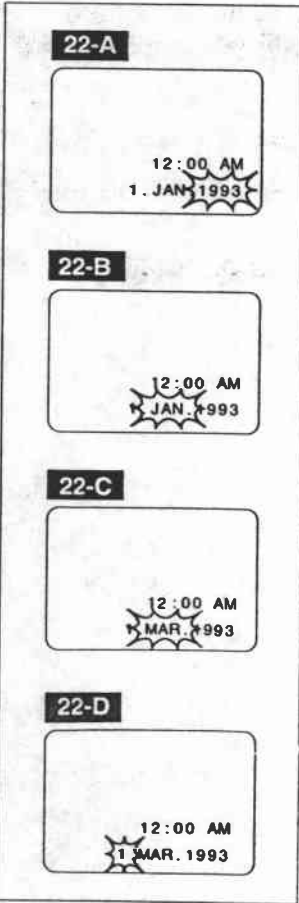
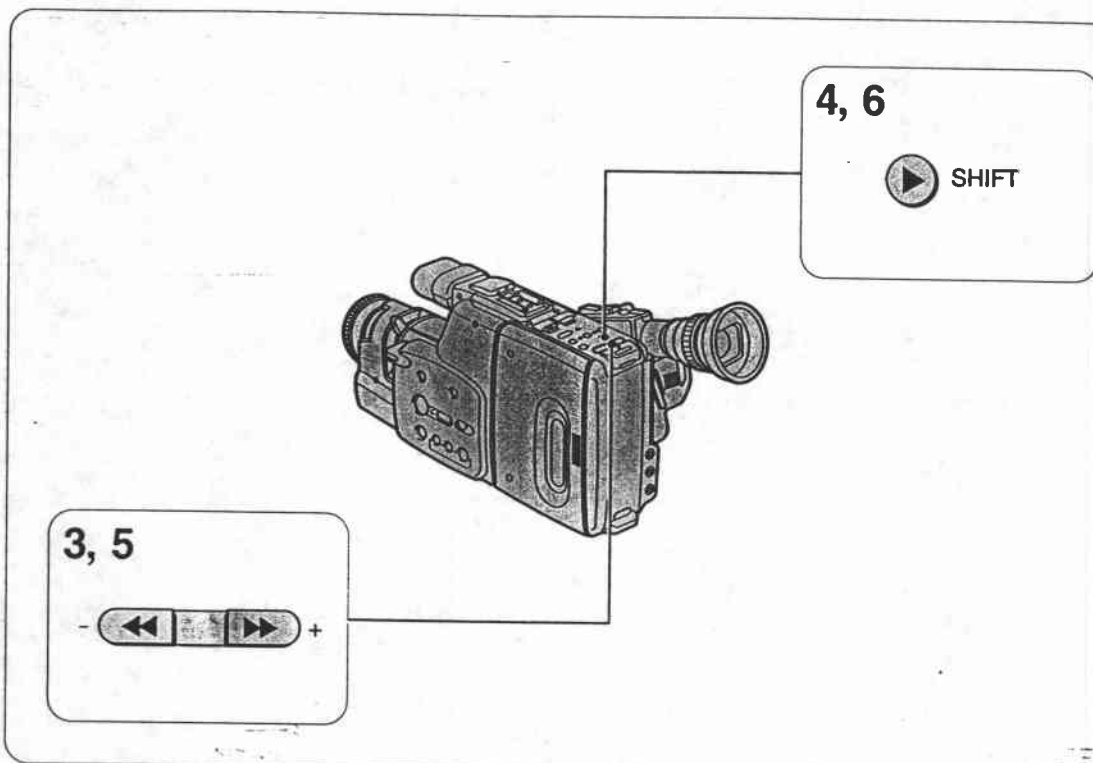

**3. Press + and – buttons to scan year display.**

**22-A**

- Press once to scan one year at a time.
  - Press and hold to scan years quickly.
  - Press – button to scan display in reverse order.
- 1992↔1993↔ .....↔ 2008↔ 2009↔ 2010←

**4. Press SHIFT button when correct year is shown.**

- Year is set and month display flashes. **22-B**

**5. Press + and – buttons to scan month display.**

**22-C**

- Press + and – buttons to scan month display.
- JAN ↔ FEB↔ .....↔ OCT↔ NOV↔ DEC←

**6. Press SHIFT button when correct month is shown.**

- Month is set and day display flashes. **22-D**

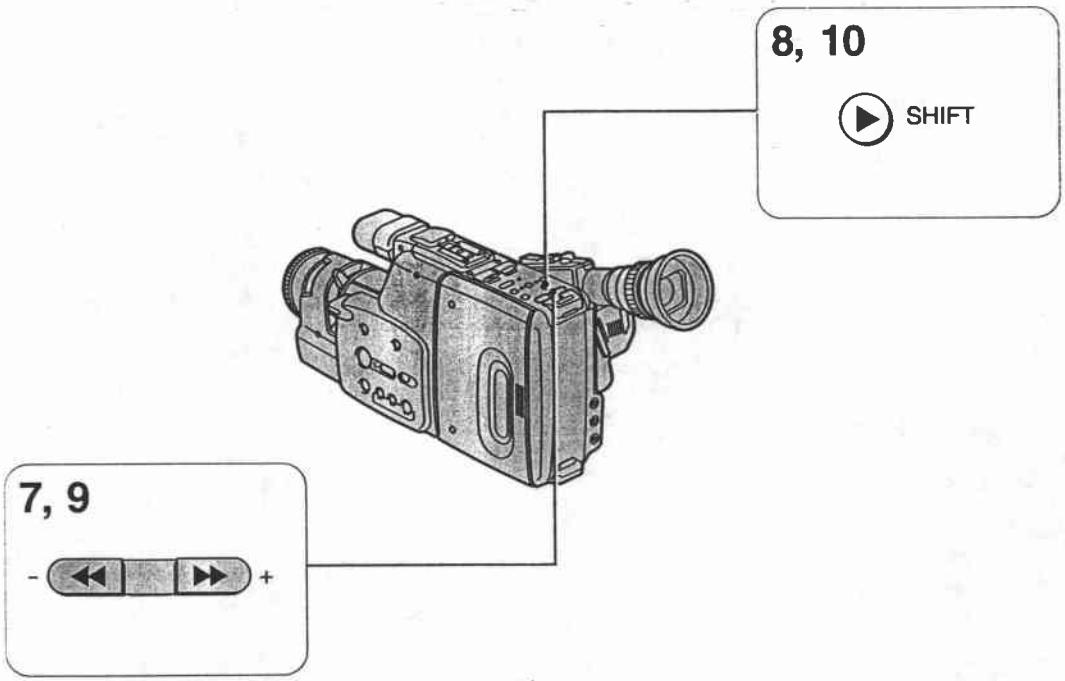

**7. Press + and – buttons to scan day display.**

- 23-A**
- The camera knows the number of days in each month and which years are leap years.
- 1 ↔ 2 ↔ 3 ↔ 4 ↔ 5 ↔ ..... ↔ 27 ↔ 28 ↔ 29 ↔ 30 ↔ 31←

**8. Press SHIFT button when correct day is shown.**

- Date is set and hour display flashes. **23-B**

**9. Press + and – buttons to scan hour display.**

- Hour display rotates through 24 hours. **23-C**
- 12AM ↔ 1AM ↔ ..... ↔ 10PM ↔ 11PM ←

**10. Press SHIFT button when correct hour is shown.**

- Hour is set and minute display flashes. **23-D**

(continued on next page)

**23-A**

12:00 AM  
20-MAR. 1993

**23-B**

12:00 AM  
20-MAR. 1993

**23-C**

2:00 PM  
20-MAR. 1993

**23-D**

2:00 PM  
20-MAR. 1993

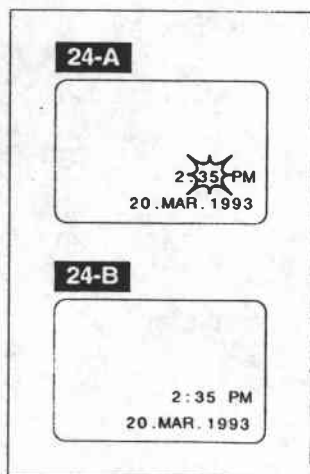
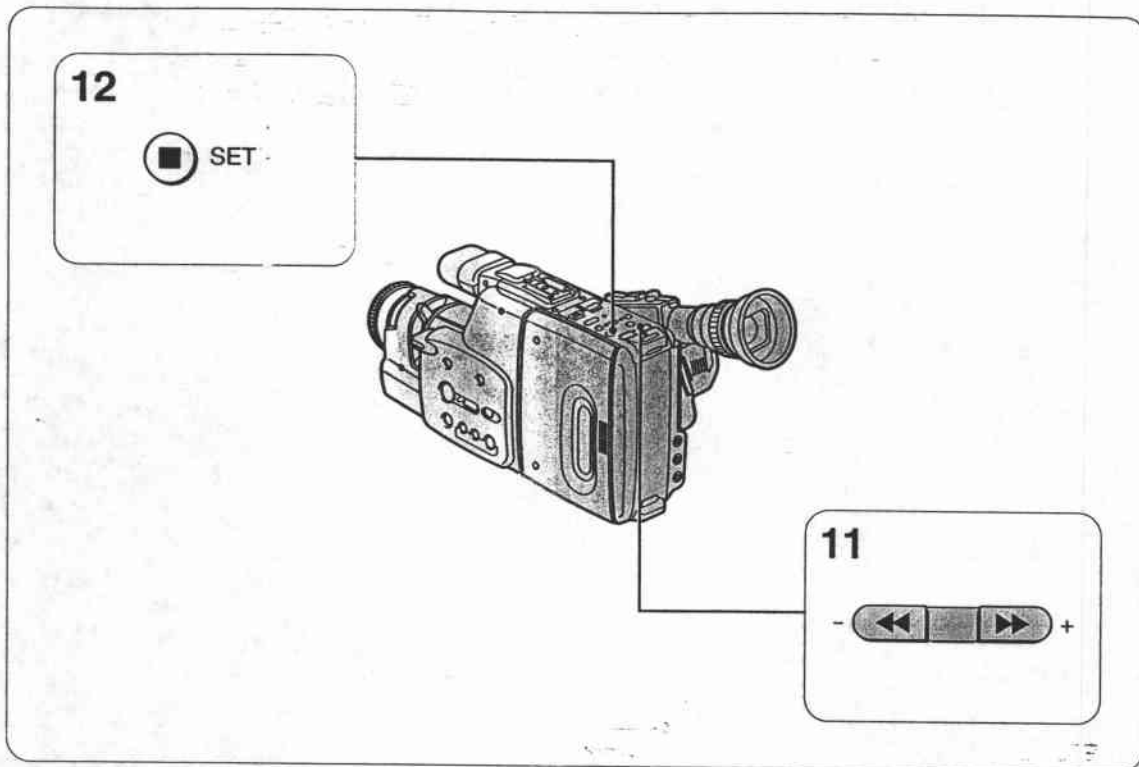

**11. Press + and – buttons to scan minute display.**

- Minute display rotates through 60 minutes. **24-A**

→00 ↔ 01 ↔ 02 ↔ ..... ↔ 58 ↔ 59←

**12. Press SET button when correct minute is shown.**

- Minute display stops flashing and auto date and time starts functioning. **24-B**
- Press DATE button to make display disappear from viewfinder.

**Notes:**

- The date can be set between 1 January, 1992, and December 31, 2010.
- Date and time cannot be set during camera recording or in PLAY mode.
- Be sure to connect a power source to the camera before changing lithium battery, otherwise, date and time will be cleared from memory and will have to be reset.
- Reset date and time when you travel to a different time zone.
- To make a partial change to date or time settings, follow steps 1 and 2 on page 21. Then press SHIFT button to select settings to change. When finished, press SET button.



# Camera Preparations

BEFORE USING

25-A



## Attaching Strap

### SS-300 Shoulder Strap **25-A**

Attach shoulder strap to the strap attachment bars, and adjust it to the most comfortable length.

### WS-20 Wrist Strap (option) **25-B**

The optional wrist strap can only be attached to the lower strap attachment bar.

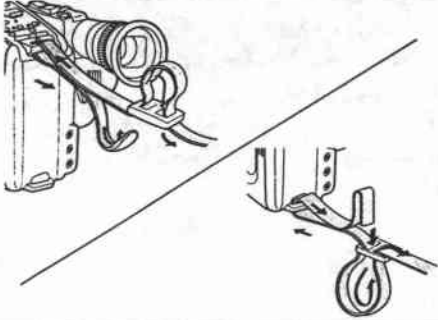

25-B

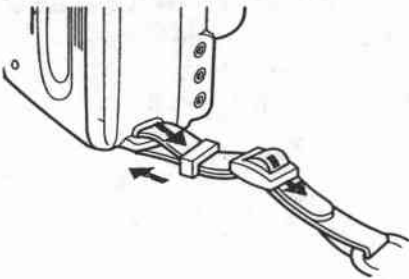
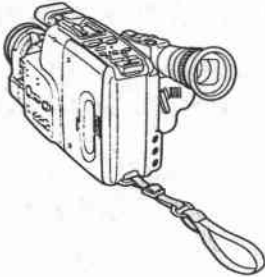

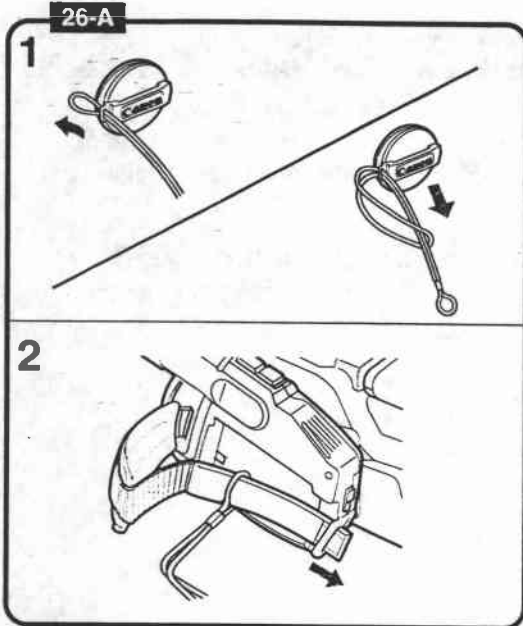

### Attaching Lens Cap Cord 26-A

1. Pass the cord provided through the loop on the lens cap.
2. Pass the grip belt through the ring of cord. Then pass the grip belt through the loop on the camera as shown.

### Removing and Attaching Lens Cap and Lens Hood 26-B

Remove lens cap before recording and hook it onto grip belt using clip on lens cap. Replace lens cap when you stop recording or turn the camera off.

- a Focusing Ring
- b Filter (option)
- c Lens Hood
- d Lens Cap

To remove the lens hood:

Gently rotate it 60° counter-clockwise, as shown, and remove.

To attach the lens hood:

Gently rotate it 60° clockwise, until it clicks into place.

- When using a filter, attach the lens hood in front of the filter so that the lens cap can be replaced.

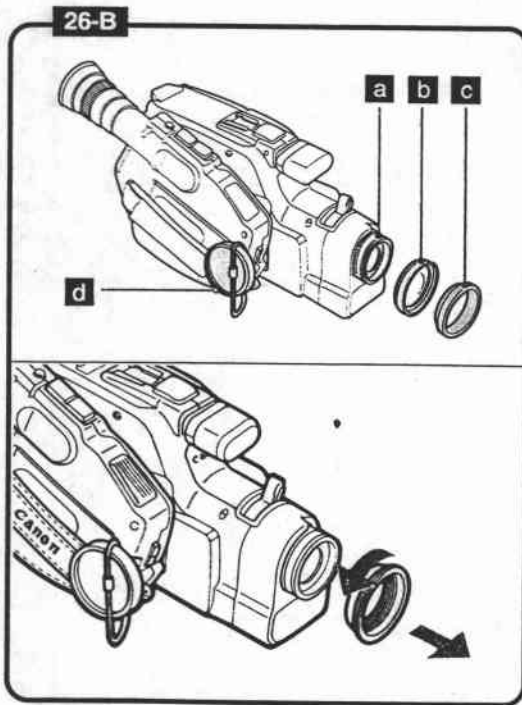

### Adjusting Grip Belt 26-C

Tighten or loosen grip belt as necessary for a comfortable fit. Hold grip with your right hand while adjusting grip belt with your left.

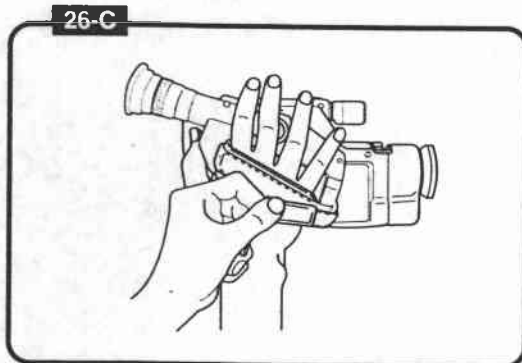

27-A

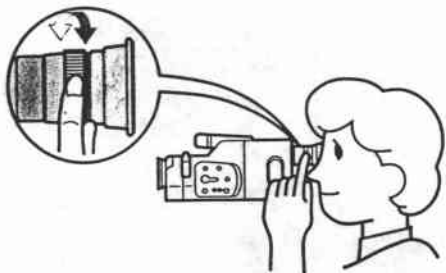

### Adjusting Diopter 27-A

Adjust the diopter to individual eyesight correction when using the camera for the first time, when changing camera operators, or when changing eye distance from the finder.

To adjust diopter:

Turn the camera on and turn diopter adjustment ring until viewfinder displays are clearly visible.

27-B

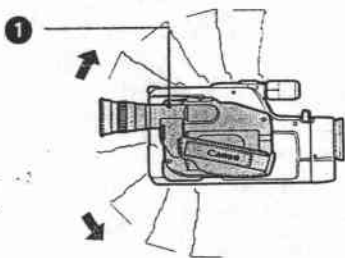

### Adjusting 180° FlexiGrip with Integral Electronic Viewfinder 27-B

The 180° FlexiGrip allows you to adjust the camera angle to 9 click-positions (every 22.5°). Turn grip while pressing the GRIP UNLOCK button and release the button in the most convenient position for shooting.

① GRIP UNLOCK Button

#### Note:

- The grip cannot be rotated when the optional RS-60 Rain Shield is used. Use the camera with the grip set horizontally.

27-C

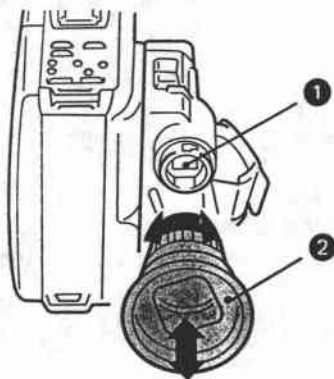

### Sports Finder 27-C

The sports finder allows you to monitor the viewfinder from as much as an arm's length from the camera.

To clean the viewfinder screen, remove the sports finder then use a commercially available blower brush.

To remove:

Align the triangular mark on finder with circle on grip.

Gently slide finder off.

To attach:

Slide finder onto grip aligning triangular mark on finder with circle on grip. Turn finder clockwise to lock in place.

- ① Viewfinder Display
- ② Sports Finder

#### Note:

- Be sure to protect the viewfinder from direct sunlight, otherwise the viewfinder will melt.

# Camera Recording (CAMERA Mode)

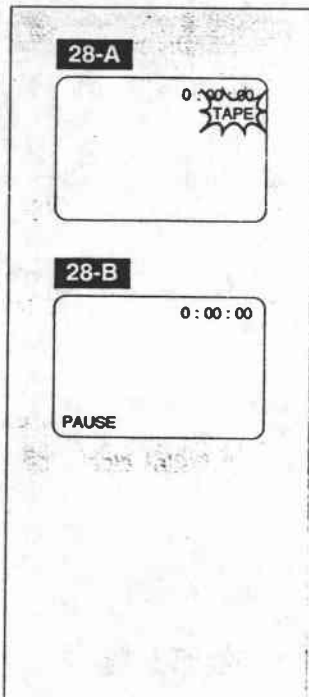
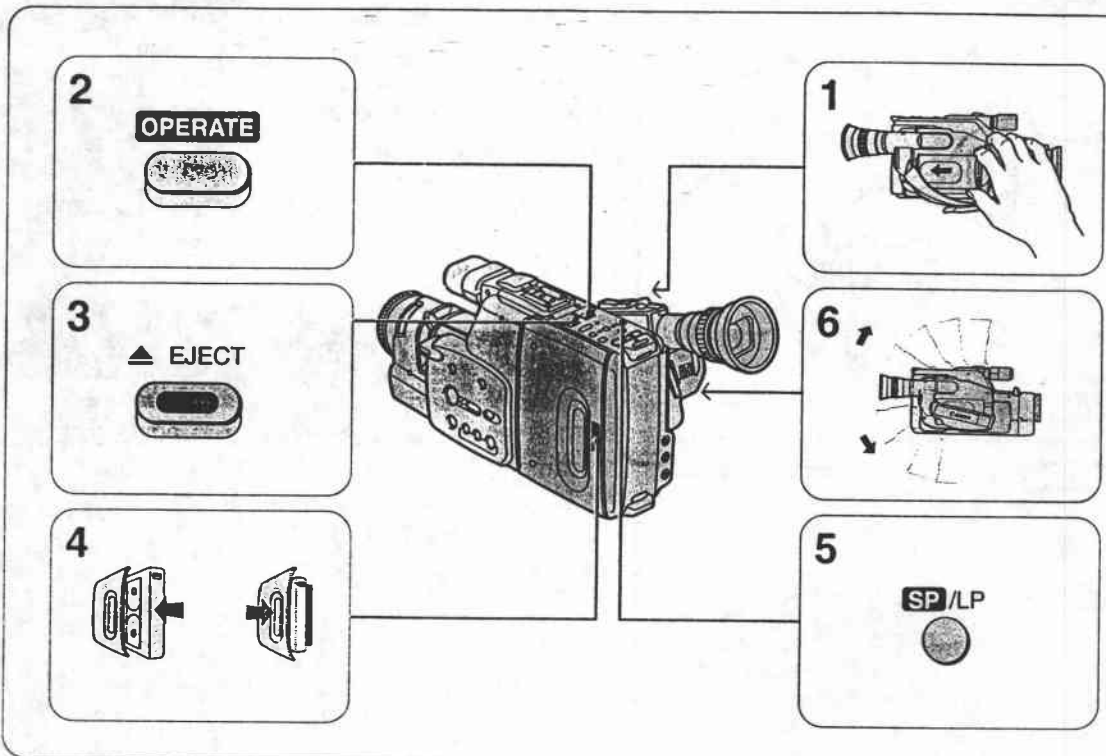

## 1. Attach power source.

- When using a battery pack, make sure it is fully charged (see p. 17).

## 2. Turn camera on.

- Mode indicator lights up red.
- "TAPE" flashes in viewfinder (see p. 32). **28-A**

## 3. Press EJECT button.

- Video cassette compartment opens.
- EJECT button works with the power turned off, if the battery pack is attached.

## 4. Load video cassette and close video cassette compartment.

- Use an 8mm video cassette marked with an **8** (P5 type).
- Camera goes into record pause mode. **28-B**

## 5. Press SP/LP button to select tape mode.

- For best picture quality, select SP.
- For double recording time, select LP.

## 6. Turn grip to desired position.

- See p. 27 for adjusting grip.

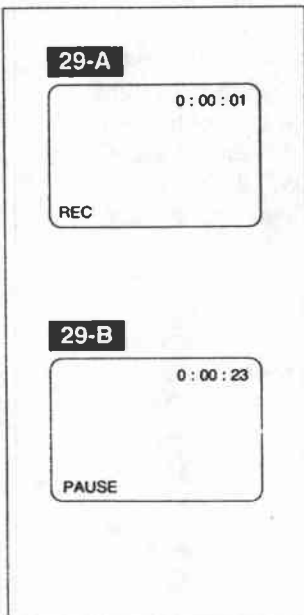
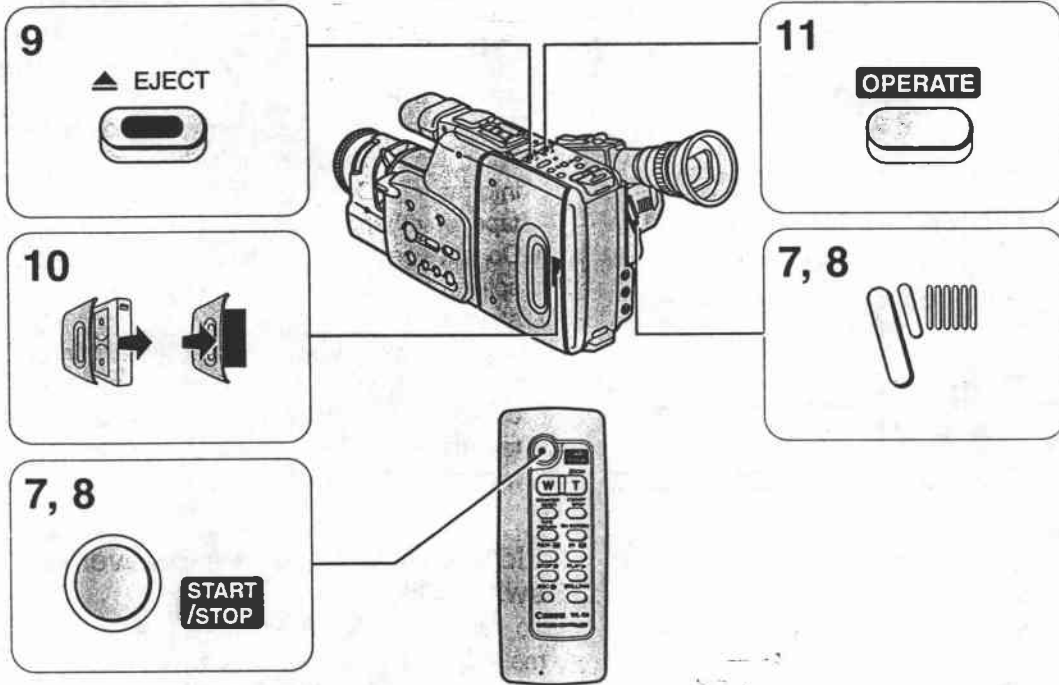

### 7. Press start/stop button.

- Recording starts.
- Tally lamp flashes rapidly and "REC" appears in viewfinder. **29-A**
- See pp. 33-63 for information on making your recordings more effective.

### 8. Press start/stop button again to temporarily pause recording. **29-B**

- Press start/stop button once again to resume recording.
- See "Record Review" (p. 34) to check your recording.

### 9. When recording has ended, press EJECT button.

- Video cassette compartment opens.

### 10. Remove video cassette and close video cassette compartment again.

### 11. Turn camera off.

- Mode indicator goes off.

#### Notes:

- The tape counter will be reset to 0:00:00 each time a video cassette is loaded.
- The camera automatically turns off if record pause mode lasts more than approximately 7 minutes. To resume recording turn camera on and press start/stop button.
- For security, check the viewfinder display for correct mode during shooting.
- Avoid recording near sources of electric or magnetic fields, such as a TV tower, which can cause noise in the picture or a camera malfunction.
- If tape speed is changed during recording, the tape will contain noise at that point.

30-A

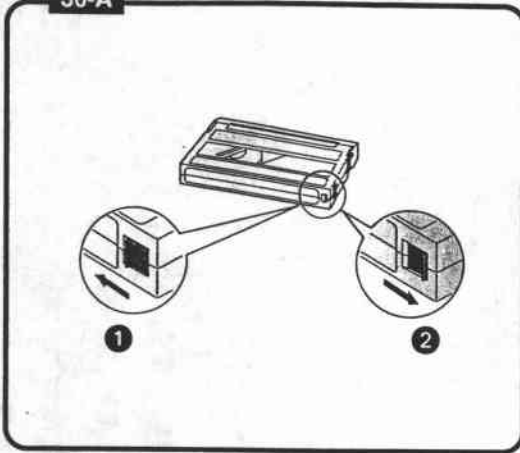

### Video Cassette Notes

- Do not leave video cassette in camera after use, especially when the camera will not be in use for a long time.
- There are several holes on the video cassette back, which are used for transferring information. Do not cover them with adhesive tape or other materials.
- Do not use video cassettes with damaged or spliced tape or ones that do not meet standards.
- To protect your video cassette put it in the plastic case, after use. Do not store video cassettes where they may be exposed to high temperatures, high humidity, direct sunlight, magnetic fields, dust or mould.

### Video cassette erasure prevention switch **30-A**

To prevent accidental erasure of recorded material, slide switch at bottom of video cassette as shown. If switch is returned to its original position, recording is possible once again.

Refer to video cassette instruction manual for more information about erasure prevention.

- In the CAMERA mode, if you load a video cassette that is set for erasure prevention, "TAPE" flashes in the viewfinder.

Use another video cassette or set switch to enable recording.

- ① To save: Erasure Prevention
- ② To record: Recording Possible

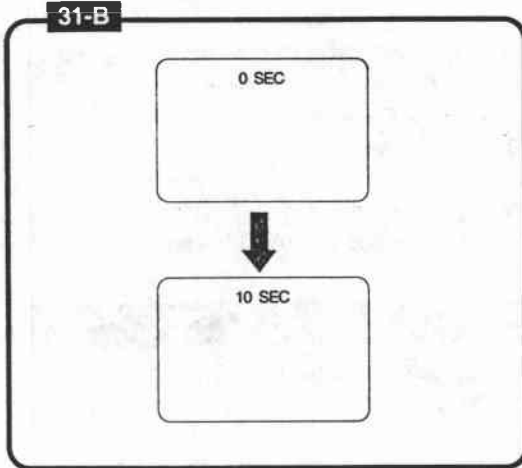
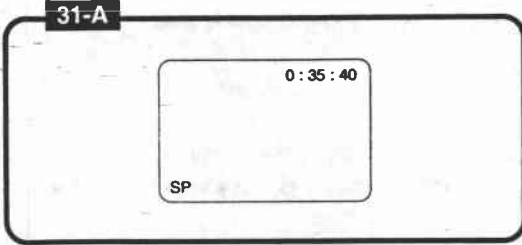

## Tape Counter

During recording, the tape counter in the viewfinder indicates how long you have recorded.

In the case shown in the diagram, you have recorded for approximately 35 minutes and 40 seconds (in SP mode). **31-A**

- The tape counter is reset to 0:00:00 when you press the C. RESET button, or each time you load a video cassette.
- The tape counter also appears during playback and record search, so you can use it to verify how long the tape has run.
- Tape counter time and actual recording length may be slightly different. Use the tape counter only as an approximate guide.
- When recording in LP mode, actual recording length is approximately twice the tape counter time.

## Recording Reminder

When you start to record, the camera counts off the first 10 seconds of your recording and displays "0 SEC" through "10 SEC" in the viewfinder. This function is designed to help you make sure your scenes aren't too short, for easy viewing and editing. Try to record for at least the full 10 seconds. **31-B**

- Recording reminder time and actual recording length may be slightly different. Use recording reminder only as an approximate guide.

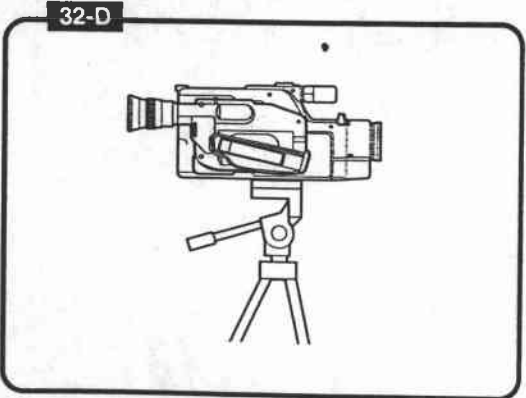
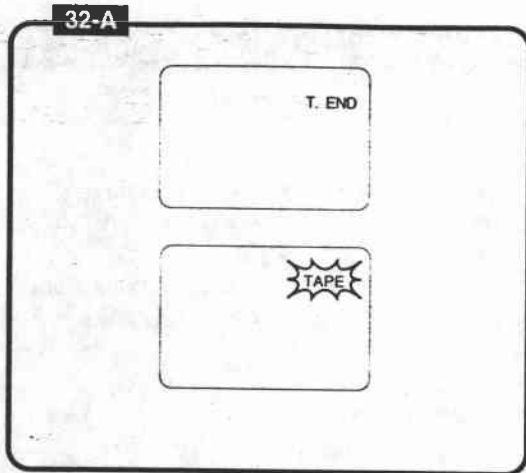

### Video Cassette Warning 32-A

- "T. END" appears in viewfinder when tape is completely used up.
- "TAPE" flashes in viewfinder if camera is turned on and a video cassette is not loaded or if the erasure prevention switch of the loaded video cassette is set to save.

### Battery Pack Warning 32-B

- "BATT" flashes in viewfinder when battery pack is nearly exhausted.
- If the camera is turned on with an exhausted battery pack attached, it may turn off immediately, without a "BATT" warning.

### About Backlighting 32-C

Backlighting, caused for example by the sun or an open window behind the subject, can cause the subject to appear underexposed and lacking in detail. This camera, using a correlated two-field metering system and a backlight compensation circuit, can adjust exposure for backlighting to some extent.

However, if the subject continues to appear underexposed, approach the subject or use the camera's zoom function to zoom in on the subject. This will reduce backlight in the picture and allow more accurate exposure. If the subject still appears underexposed, use the VL-7 Battery Video Light (see p. 44).

### Recording Using Tripod 32-D

Use a tripod especially in the following cases:

- Telephoto recording
- Macro recording
- Self-timer recording
- Interval timer recording
- Recording using wireless controller

**Note:**

- Be sure to protect the viewfinder from direct sunlight, otherwise the viewfinder will melt.



# Record Search (Assembly Editing) (CAMERA Mode)

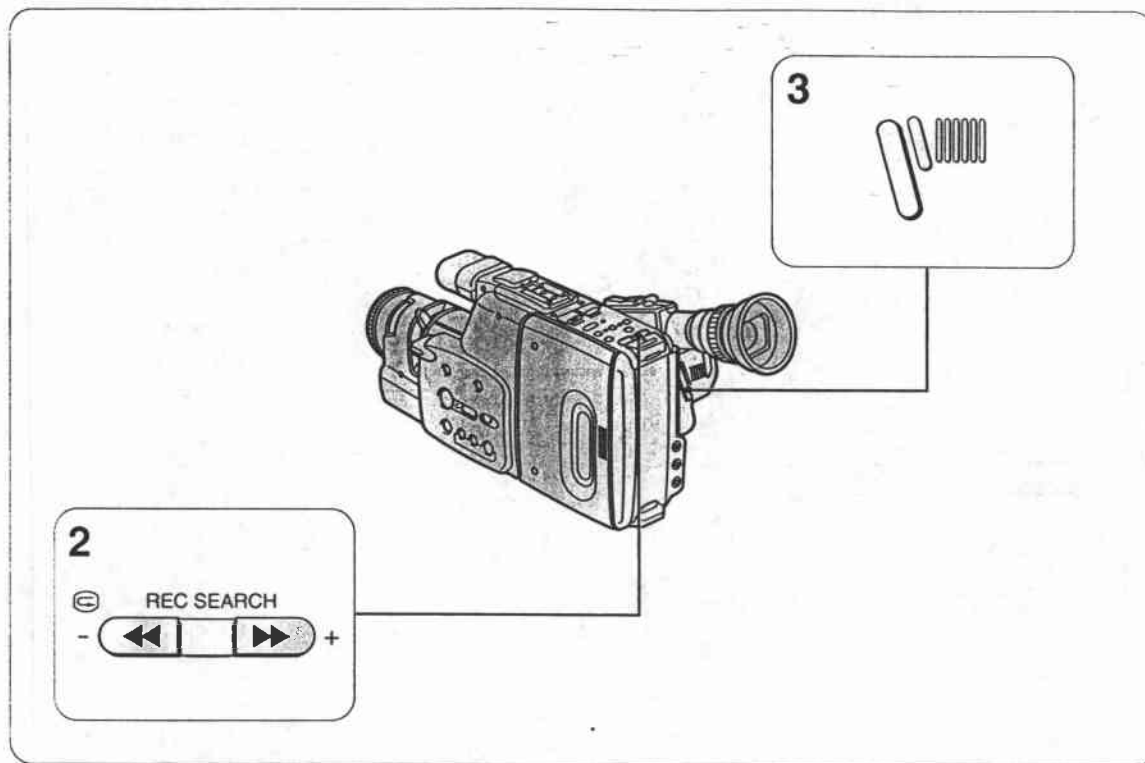

RECORDING

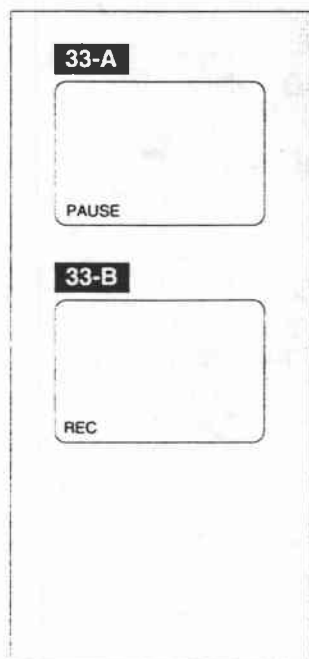



Use record search to locate the desired point to resume recording. Record search can also be used to eliminate noise between recorded scenes. Use this function when you make additional recordings on a previously used video cassette — there will be no noise between a previously recorded scene and a newly recorded scene.

- 1. Place camera in record pause mode. 33-A**
- 2. Press + or – button to scroll forward or backward to locate recording start position.**
  - Press and hold the + button to play back the recording forward.
  - Press and hold the – button to play back the recording backward.
  - Camera returns to record pause mode when you release the buttons.
- 3. Press start/stop button.**
  - Recording starts. 33-B
  - Tally lamp flashes rapidly.

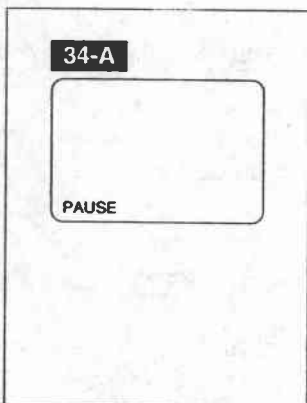
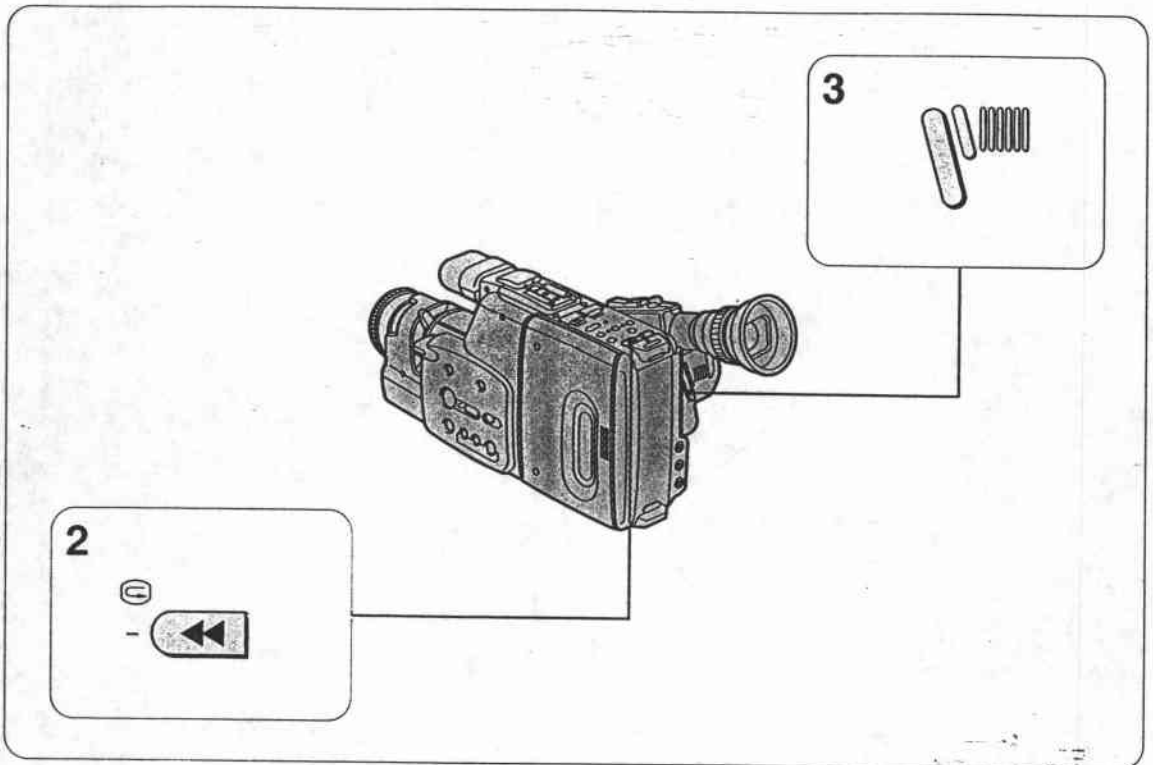
# Record Review (CAMERA Mode)



Press  (Record Review) button during record pause mode to play back the last segment of recorded scene (approximately 3 seconds) in the viewfinder. Once playback is complete, the camera returns to record pause mode where it left off.

- 1. Place camera in record pause mode.** 
- 2. Press  button.**
  - Scene plays back in viewfinder.
  - Camera returns to record pause mode after record review has ended.
- 3. Press start/stop button to resume recording.**
  - Tally lamp flashes rapidly.

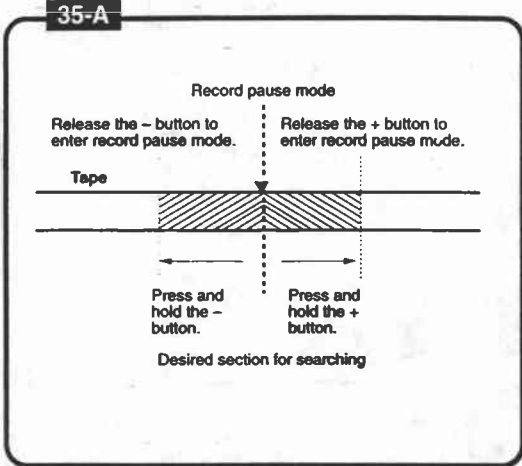

**Explanation:**

**Record search (to resume recording) 35-A**

Searches the desired section to start recording, while in record pause mode.

**Explanation:**

**Record review 35-B**

Plays back your recording in the order ① to ③ after record pause mode is entered. The camera returns to record pause mode after playback has ended.

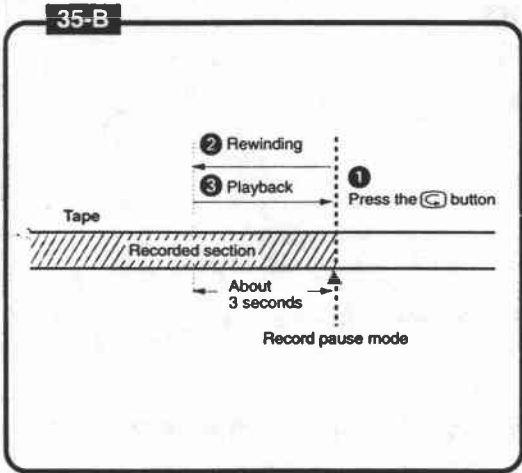

**35-C**



**35-D**



**Notes:**

- Noise **35-C** or skew **35-D** may appear on the screen during record review mode or record search mode. This is not a malfunction.
- During record review no other operation works. However, if the OPERATE button is pressed, the power turns off.

# Recording Date and Time (CAMERA Mode)

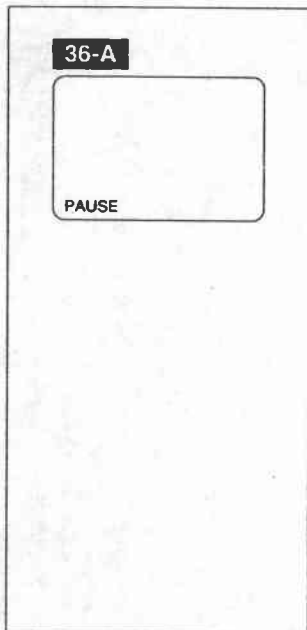
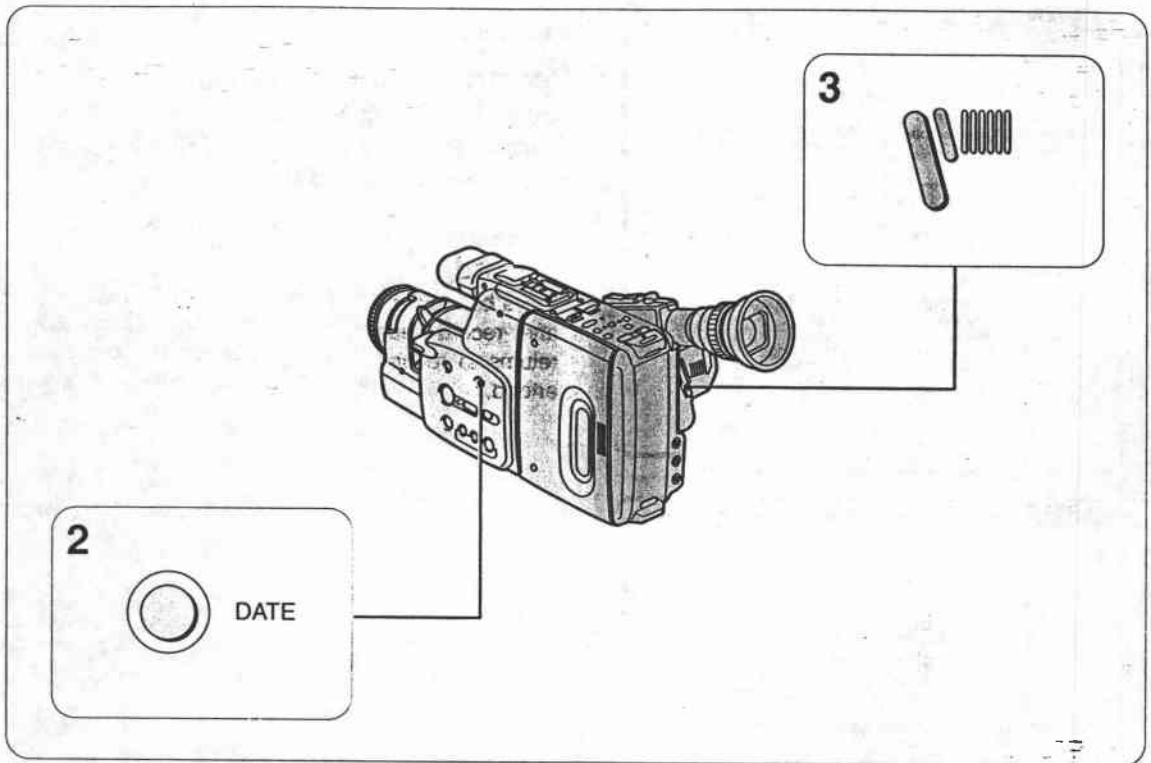

You can record the date and time separately or together, and with or without a title.

- For setting date and time, see p. 21.

1. Place camera in record pause mode. **36-A**
2. Press DATE button to select display for recording as follows:

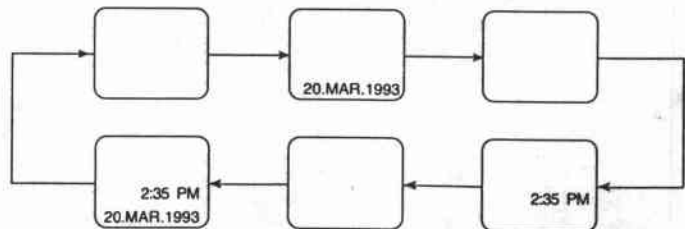

3. Make your recording as normal.
  - Date and/or time are recorded with scene.

## Notes: 1

- When lithium battery is nearly or completely exhausted "DATE" flashes in viewfinder. Change lithium battery (see p. 20).
- The date and time can be also displayed during playback (see pp. 77-79).

# Focusing (CAMERA Mode)

37-A



Two focusing systems are available to suit your needs: autofocus and manual focus.

## Autofocus 37-A •

The camera enters autofocus mode as soon as you turn the camera on. Focus adjusts automatically to suit the subject located in the centre of the viewfinder.

- The camera transmits infrared beams to the subject and receives reflected beams at the autofocus window to focus automatically. When the subject is at a distance of approximately 6 metres, focus is adjusted in the centre of the viewfinder. For subject distances greater than 6 metres, camera focus point is slightly higher and to the left in the viewfinder; for distances less than 6 metres, camera focus point is slightly lower and to the right. For very close subjects at a distance of less than approximately 1 metre, this shift of focus becomes more obvious.

Also, the shift of focus becomes more obvious at the telephoto end. (Infrared beams focus on a point within circles which shift according to distance.)

37-B

RECORDING

37-B

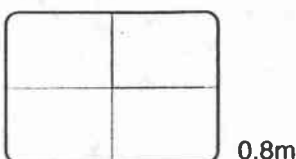
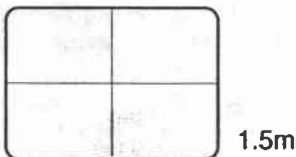
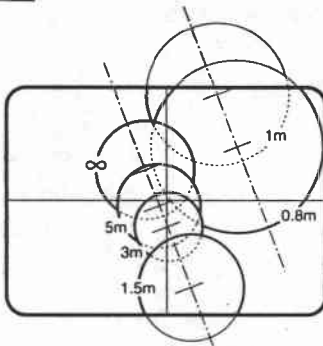

38-A

A



B



C



D

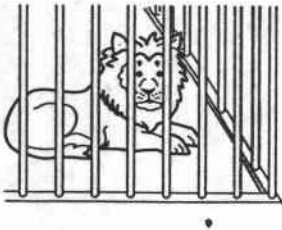

E

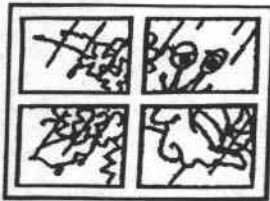

F



## Subjects Not Suitable for Autofocus

38-A

Autofocus may not work well in the following instances, and manual focus will probably give you better results:

- A. Subjects with very glossy or shiny surfaces (e.g. car exteriors)
- B. Subjects with little or no reflection (e.g. dark clothes, dark hair, water surface)
- C. Scenes that cause a strong contrast between right and left halves of the screen
- D. Partially obscured subjects
- E. Subjects behind glass
- F. Backlit subjects

### Notes:

- Be sure not to obscure autofocus window located under the lens with your hand, fingers, etc. during recording.
- Do not touch focusing ring during autofocus.
- The autofocus mechanism focuses on subjects at a distance of 0.7–12 metres. For more distant subjects the focus locks at 100 metres. When you zoom in on subjects that are more than 100 metres away, manual focus may be more effective.
- When shooting night scenes or subjects in cloudy or low-light conditions, at a distance of 12 metres or more, manual focus may be more effective.
- If the camera is near other products that use infrared beams (e.g. wireless controller for TV, VTR, or another video camcorder), autofocus may malfunction. Autofocus is turned off when the camera receives signals from the wireless controller.
- Shooting subjects in low-light conditions at a distance of less than 1 metre in autofocus mode may result in poor picture quality. To avoid this, use the VL-7 Battery Video Light.

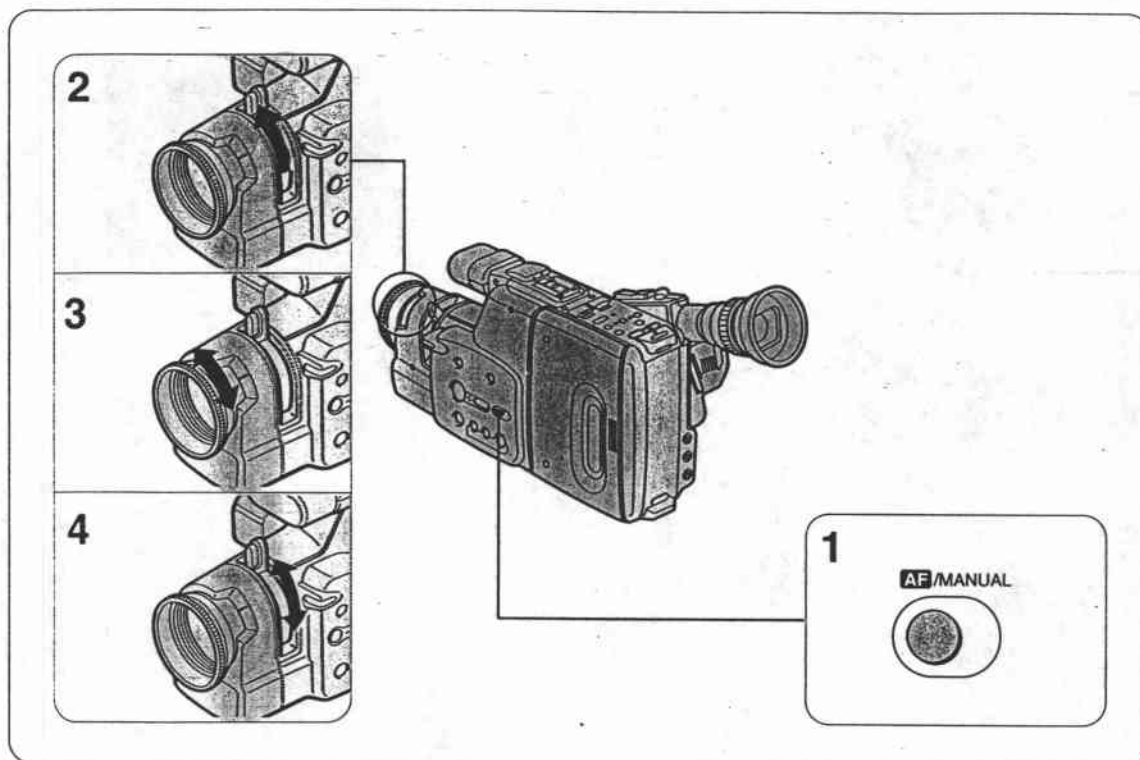

39-A

M. FOCUS

### Manual Focus

Use manual focus when you shoot subjects not suitable for autofocus.

1. Press **AF/MANUAL** button to select manual focus.
  - "M. FOCUS" appears in viewfinder. **39-A**
2. Rotate zooming lever to telephoto end.
3. Look through viewfinder and rotate focusing ring to focus on subject.
4. Use zooming lever to frame subject properly.
  - Camera automatically returns to autofocus when camera is turned off or placed in PLAY mode.
  - Press AF/MANUAL button to stop manual focus and return to autofocus ("M. FOCUS" disappears from viewfinder).

### Focus Lock

When you press the AF/MANUAL button during autofocus, the focus can be locked on the subject focused at that time, even if the subject moves to the right or left of centre. To focus on another subject, adjust with the focusing ring or press the AF/MANUAL button again and adjust with autofocus.

# Macro Recording (CAMERA Mode)

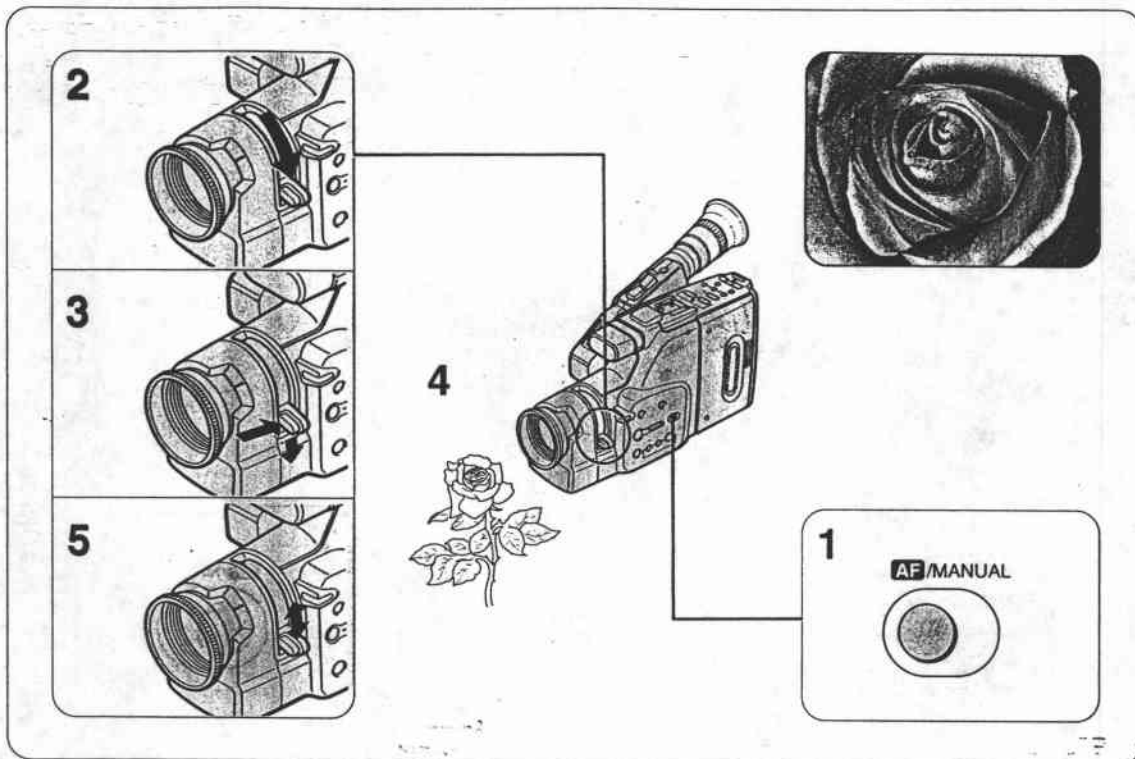

40-A

M. FOCUS

Macro recording allows you to record small subjects such as flowers and insects close-up, to full screen, and achieve extremely fine detail in your pictures.

1. Press **AF/MANUAL** button to select manual focus.
  - "M. FOCUS" appears in viewfinder. **40-A**
2. Rotate zooming lever to wide-angle end.
3. Press and hold macro button on zooming lever and move lever into macro range.
4. Approach subject to desired size in viewfinder.
  - Be sure there is adequate lighting.
  - You can approach the subject as close as 4 mm.
5. Use zooming lever within macro range for fine focusing.
  - Focus within macro range.
6. When macro recording is completed, reverse steps 2 and 3.

## Notes:

- Move camera forward or backward slightly to change subject image size and then fine focus again.
- A tripod is recommended for better recording stability.
- If necessary, remove the lens hood (see p. 26).



# Zooming (CAMERA Mode)



41-A

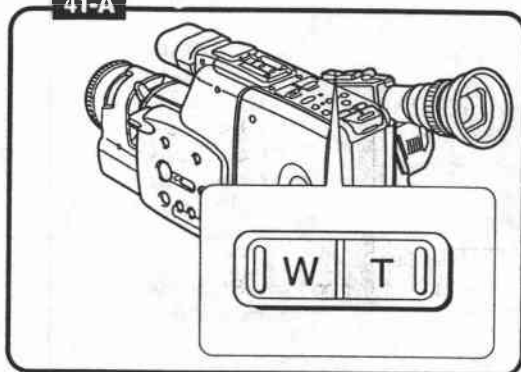

Zoom in on hard-to-catch subjects or add close-up personal touches to your recordings. Zoom out to reveal a breathtaking view. The camera has 3 zooming methods: power zoom, manual zoom and wireless zoom.

## Power Zoom 41-A

Press power zoom buttons on the grip. Press and hold T to gradually zoom in to telephoto.

Press and hold W to gradually zoom out to wide angle.

41-B

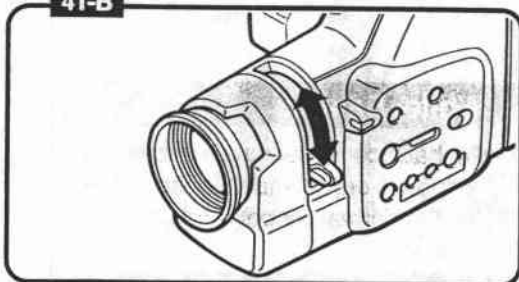

## Manual Zoom 41-B

Turn zooming lever to rotate zooming ring.

41-C

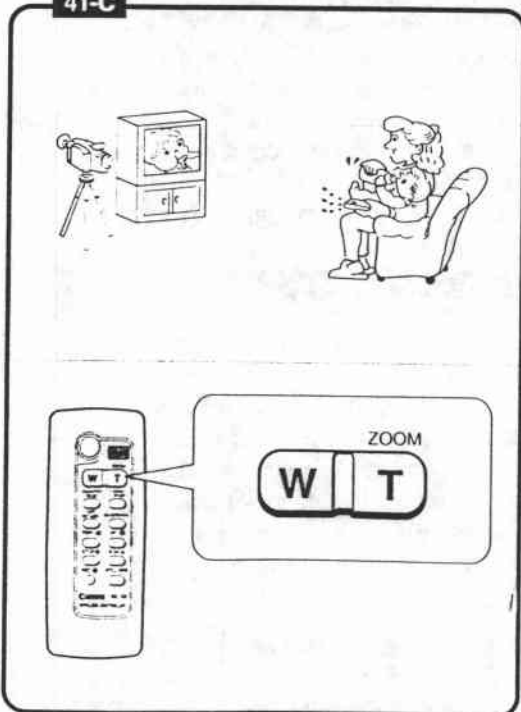

## Wireless Zoom 41-C

The wireless controller allows you to control zoom operation from a distance.

Press and hold ZOOM T button to gradually zoom in to telephoto.

Press and hold ZOOM W button to gradually zoom out to wide angle.

- Mount camera on a tripod.
- Use a TV monitor during wireless zooming to view shots.

### Notes:

- Even the slightest hand movement will appear in the recording when shooting in the telephoto range. Use a tripod for better results.
- Overuse of zooming may make recordings seem too busy. Selective use of zooming is more effective.

# White Balance (CAMERA Mode)

## What is White Balance?

The human eye can perceive a white object as white, regardless of the lighting conditions. With video cameras, however, the colour temperature of the light source may cause the colour of the recorded picture to be different from the actual colour. White balance is the adjustment made, when recording, to obtain natural whites and colours under a variety of light sources. The camera has 2 systems for white balance adjustment: auto and lock.

### Explanation:

Colour temperature, measured in degrees Kelvin (K), indicates the relative redness or blueness of a light source and is not directly related to brightness. A light source with a red cast has a low colour temperature, whereas a bluish light source has a higher colour temperature.

## Colour Temperature Chart

Adjustable White Balance Range	Bluish Cast	10,000 K 9,000 K 8,000 K 7,000 K 6,000 K 5,000 K	<ul style="list-style-type: none"> <li>• Blue sky</li> <li>• Scene on TV screen</li> <li>• Cloudy sky</li> <li>• Sunlight</li> </ul>
	White	4,000 K 3,000 K	<ul style="list-style-type: none"> <li>• White fluorescent light</li> <li>• 2 hours after sunrise or before sunset</li> <li>• 1 hour after sunrise or before sunset</li> <li>• Electric halogen light</li> <li>• 30 minutes after sunrise or before sunset</li> <li>• White electric light bulb</li> </ul>
	Reddish Cast	2,000 K 1,500 K	<ul style="list-style-type: none"> <li>• Sunrise, sunset</li> <li>• Candlelight</li> </ul>

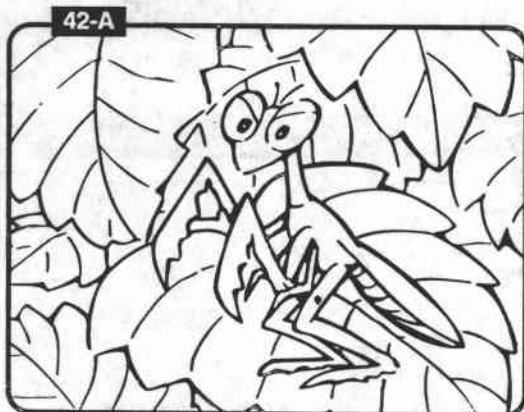

## Auto White Balance

Auto white balance is set automatically when camera is turned on, to make white balance adjustment for normal indoor and outdoor conditions.

## Subjects Not Suitable for Auto White Balance 42-A

Auto white balance may not work well in the following instances, and white balance lock will probably give you better results:

- Subject with one dominant colour, such as sky, sea or forest.
- Subject for a macro recording, such as a close-up of a flower.

## White Balance Lock

Use white balance lock when you shoot subjects not suitable for auto white balance.

- White balance lock also works without using a white object (see p.43). Set the power zoom to wide-angle end and press AWB/LOCK button to adjust for the scene. However, this is not suitable for scenes with one dominant colour or for macro recording.

### Notes:

- White balance lock clears automatically when in PLAY mode or the camera is turned off.
- Reset white balance again if the light source changes during white balance lock.
- Use white balance lock even under normal lighting conditions to achieve a more precise colour balance.

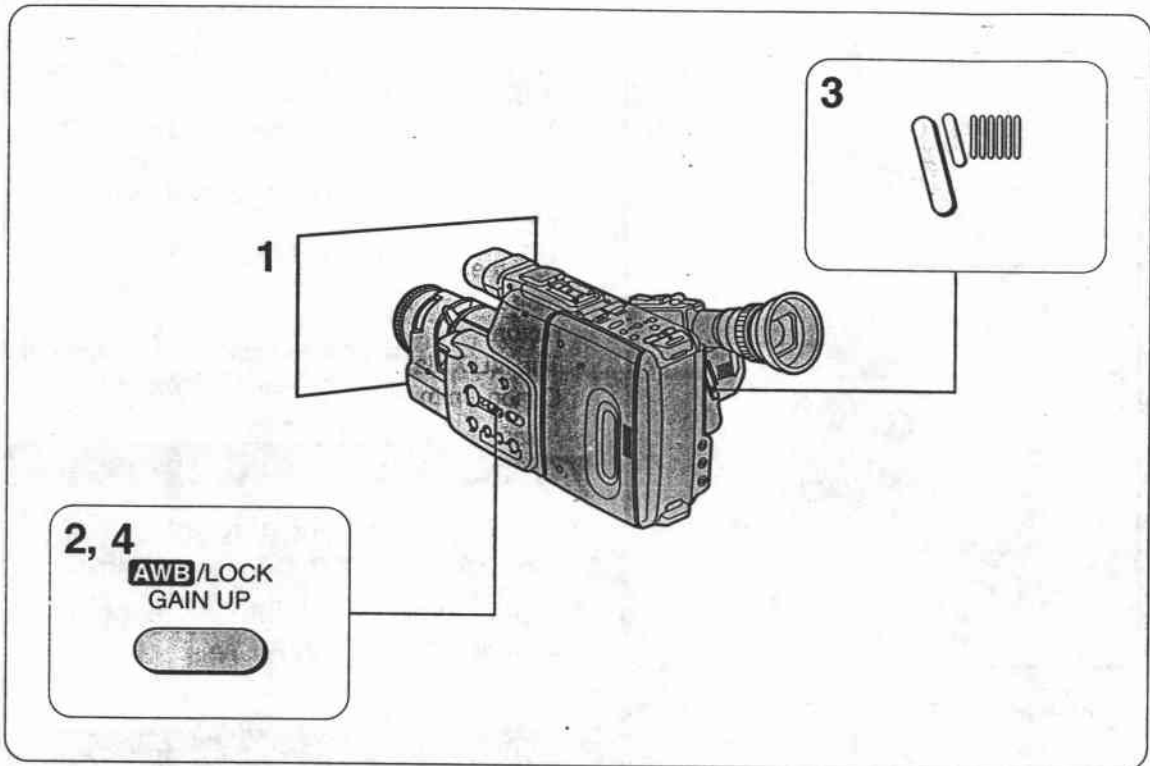

### White Balance Lock Procedure

43-A

WB LOCK

1. Point camera lens at a white object (such as a sheet of paper) for 10 seconds, so it completely fills viewfinder.
  - Set zooming lever to telephoto end.
  - Be sure sufficient lighting is available.
  - There is no need for focusing.
2. Press **AWB/LOCK/GAIN UP** button.
  - "WB LOCK" appears in viewfinder. **43-A**
3. Make your recording.
4. Press **AWB/LOCK/GAIN UP** button again to reset auto white balance.
  - "WB LOCK" disappears from viewfinder.

**Note:**

- Pressing the AWB/LOCK/GAIN UP button for more than 3 seconds engages gain-up function.

# Shooting with Video Light (CAMERA Mode)

44-A

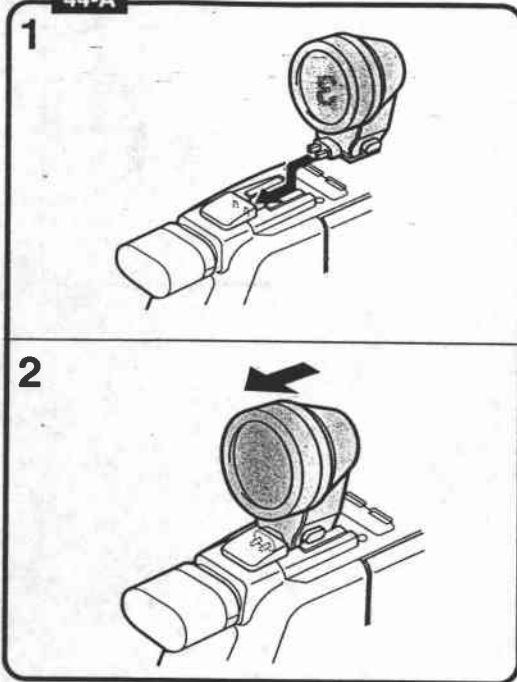

When shooting with backlighting or in a dark room, use the VL-7 Battery Video Light, which is powered by the BP-E77K or BP-E722 (option) Battery Pack.

- The duration of illumination with the BP-E77K is approximately 15 minutes. For longer shooting, be sure to have an extra battery pack.
- Use the video light within approximately 3 metres from the subject to ensure a clear picture.
- The VL-7 Battery Video Light can be used with Canon 8mm video cameras marked with 

## Attaching Video Light 44-A

1. Insert video light plug into accessory shoe on the camera.
2. Slide video light into accessory shoe until it stops.

44-B

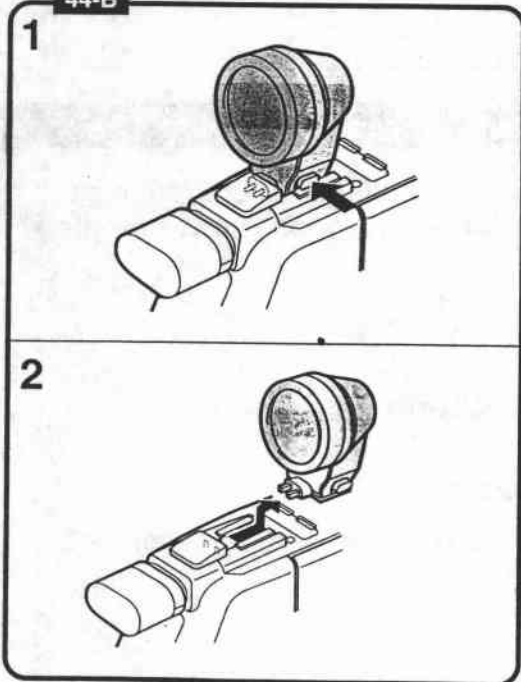

## Removing Video Light 44-B

1. Press and hold lock release button.
2. Slide video light out of accessory shoe.

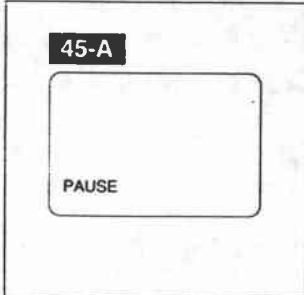
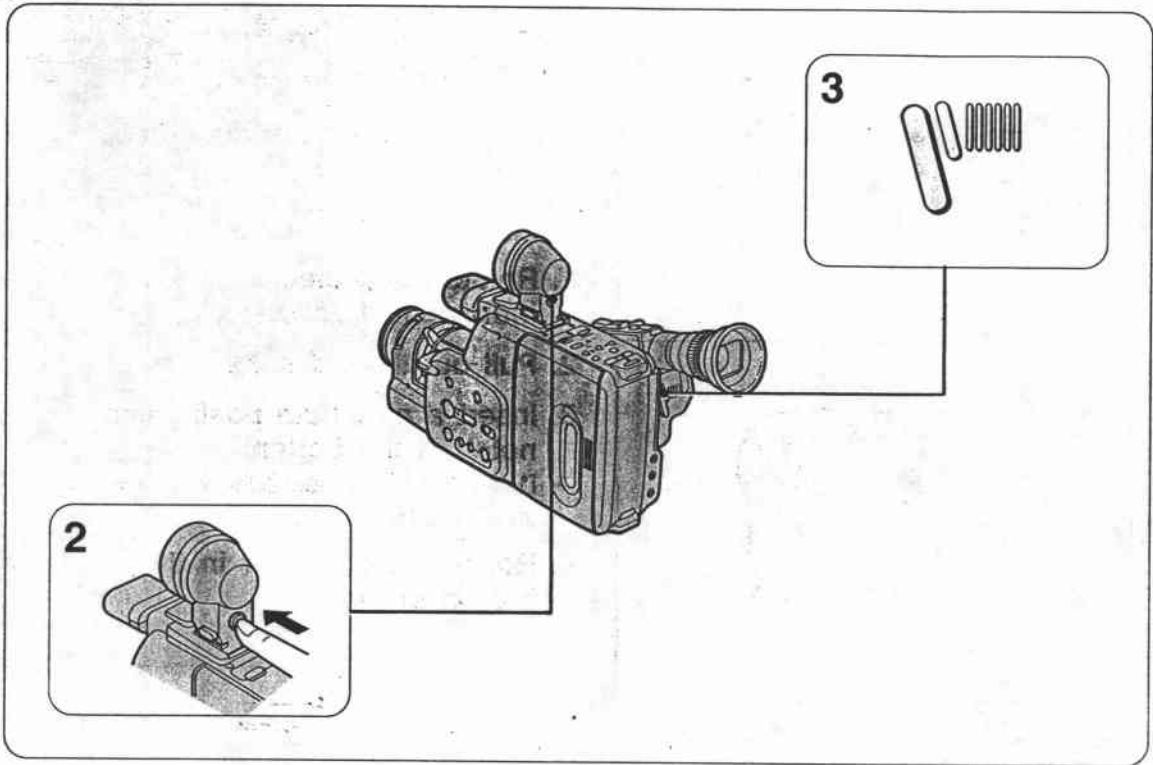

### Shooting with Video Light

1. Place camera in record pause mode. **45-A**
  - Mode indicator lights up red.
2. Press video light power button.
3. Press start/stop button to start shooting.
  - To turn off video light during shooting, press video light power button again.

**Note:**

- The video light can be used only during recording or record pause mode.

# Gain-up (CAMERA Mode)

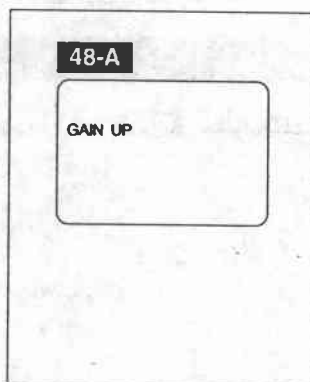
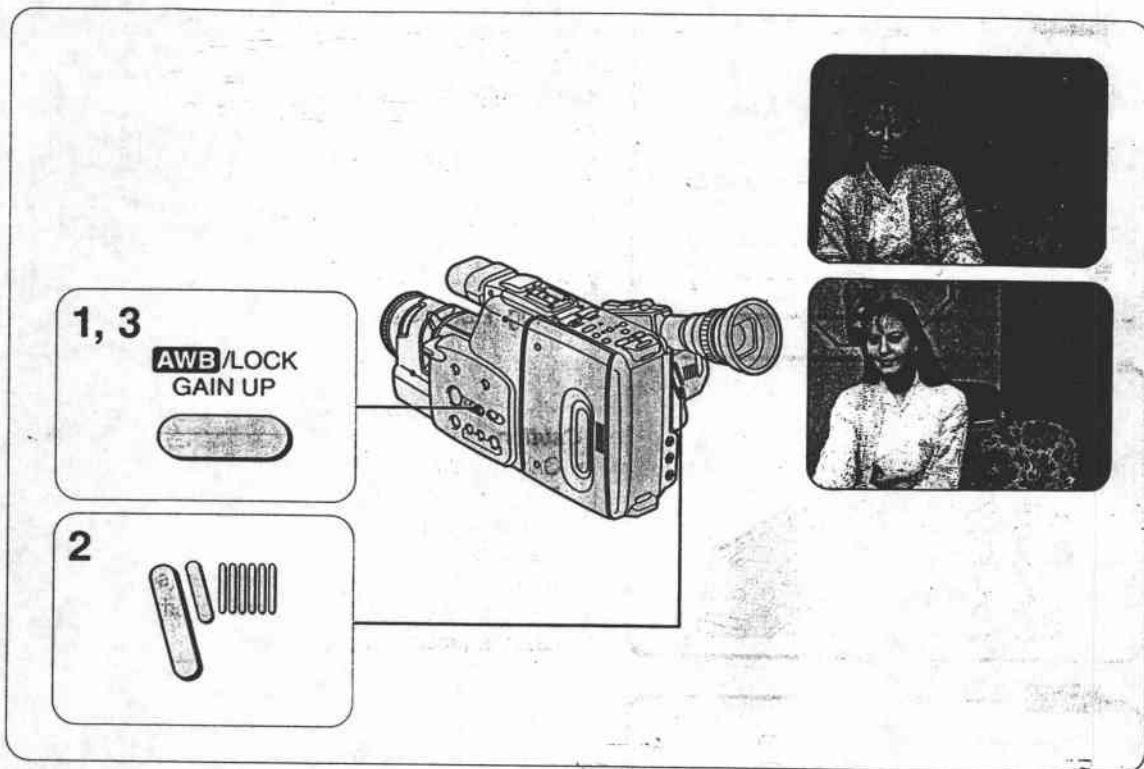

The gain-up function lets you record more brightly than usual, especially for when you are recording in dimly lit places.

1. Press and hold **AWB/LOCK/GAIN UP** button for more than 3 seconds.
  - "GAIN UP" appears in viewfinder. **48-A**
2. Make your recording.
3. Press **AWB/LOCK/GAIN UP** button for more than 3 seconds to cancel gain-up.
  - "GAIN UP" disappears from viewfinder, and recording continues.

## Notes:

- With gain-up, picture quality will suffer somewhat. Cancel gain-up when recording in a brightly lit area.
- It may be impossible to record in extremely dark places, even when using the gain-up feature. When recording from only a short distance, use the video light supplied with your camera.
- If you turn off the power or switch to PLAY mode, gain-up will automatically be cancelled.

# High-speed Shutter (CAMERA Mode)

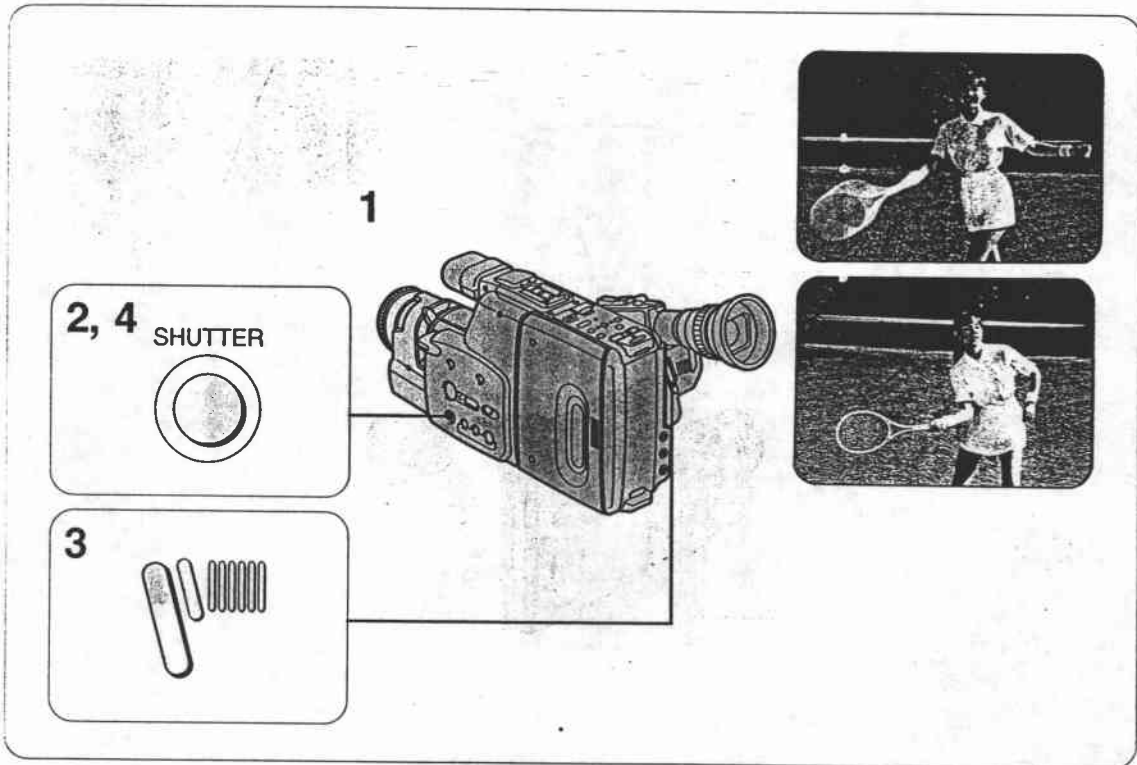

RECORDING

The high-speed shutter allows you to capture sports and other fast action scenes clearly. The camera has 7 high-speed shutter settings: 1/60th, 1/250th, 1/500th, 1/1000th, 1/2000th, 1/4000th, and 1/10000th of a second. Select the correct shutter speed according to subject speed and brightness. Normal shutter speed is 1/50th of a second.

**1. Point camera at subject and compose scene in viewfinder.**

**2. Press SHUTTER button.**

- Each time button is pressed, viewfinder display changes as follows:

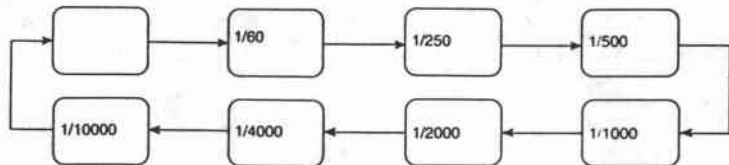

**3. Make your recording.**

**4. Press SHUTTER button to return to normal shutter speed.**

**Notes:**

- Use this function outdoors with bright light.
- Scenes shot with the high-speed shutter will appear somewhat jerky during normal playback.
- Scenes shot with the high-speed shutter work best with special playback. Use a VTR capable of noise-free special playback for best results.
- If you turn off the power or switch to PLAY mode, shutter setting automatically returns to normal (1/50).

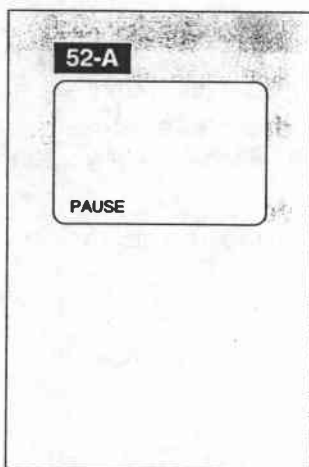
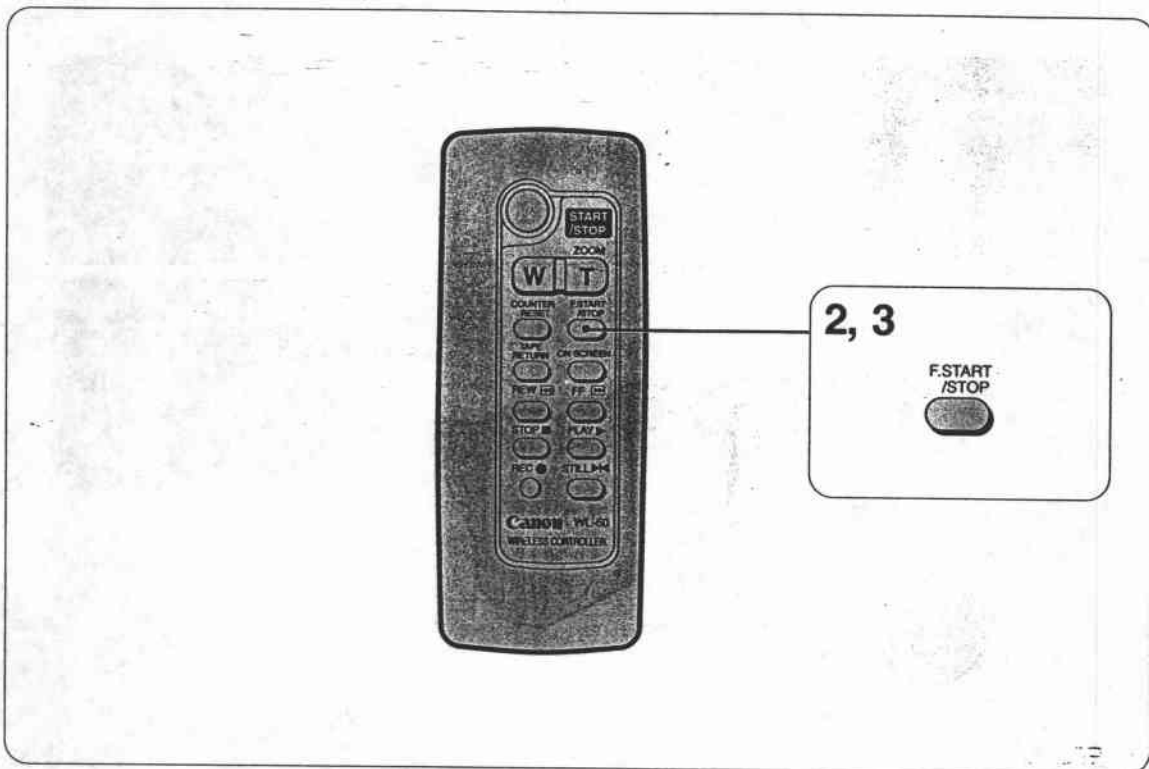

## Wireless Fade

The F. START/STOP button on the wireless controller lets you begin and end recording with a smooth fade in and fade out.

1. Place camera in record pause mode. **52-A**
2. Press F. START/STOP button.
  - Scene disappears, camera recording begins within 1 or 2 seconds, and then picture fades in.
3. When scene is recorded, press F. START/STOP button again.
  - Scene fades out, then camera enters record pause mode in about 4 seconds.



# Timer Recording (CAMERA Mode)

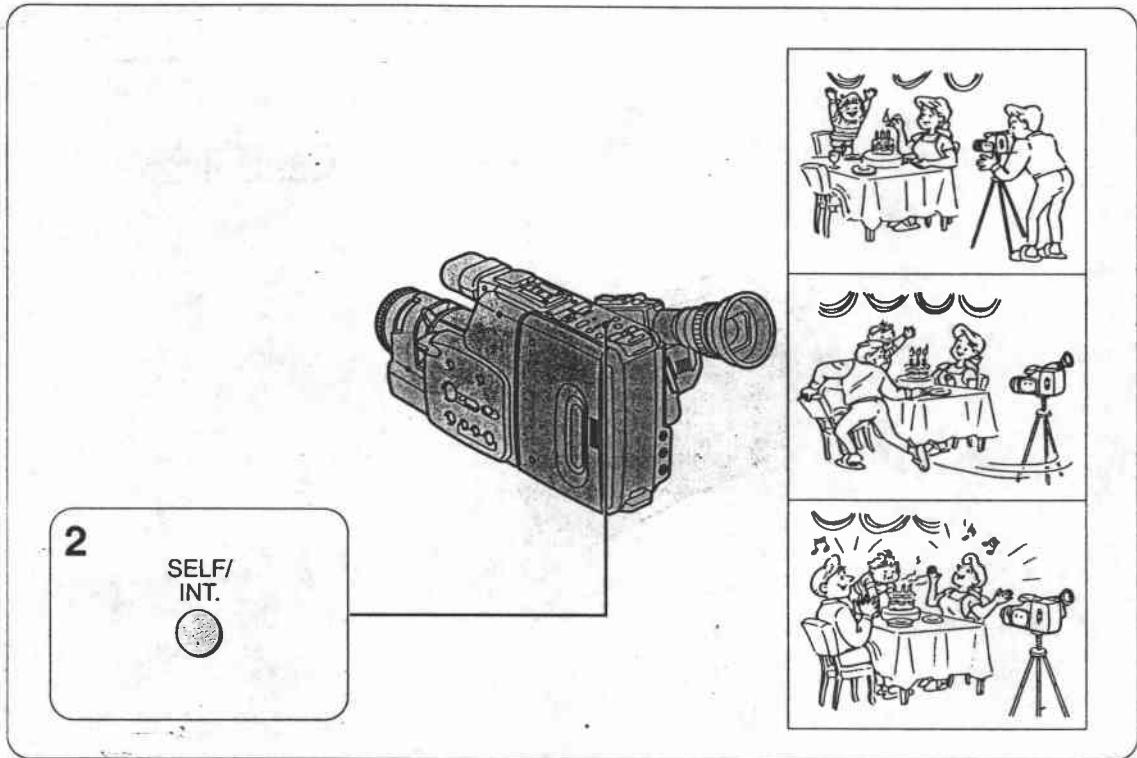

RECORDING

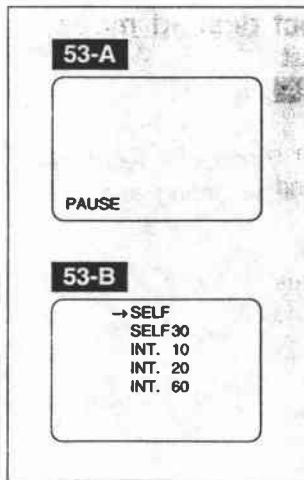

Set the self-timer and the camera will automatically start recording after a 10-second standby period, letting you get in on the action. The camera can be set to record for 30 seconds or until you turn it off.

Interval timer sets the camera to record for about 0.5 seconds each time a fixed interval passes. This allows you to record the changes in scenes like flowers blooming, animals activities or even your own daily activities.

1. Place camera in record pause mode. **53-A**
2. Press **SELF/INT.** button.
  - Menu appears in viewfinder. **53-B**

(continued on next page)

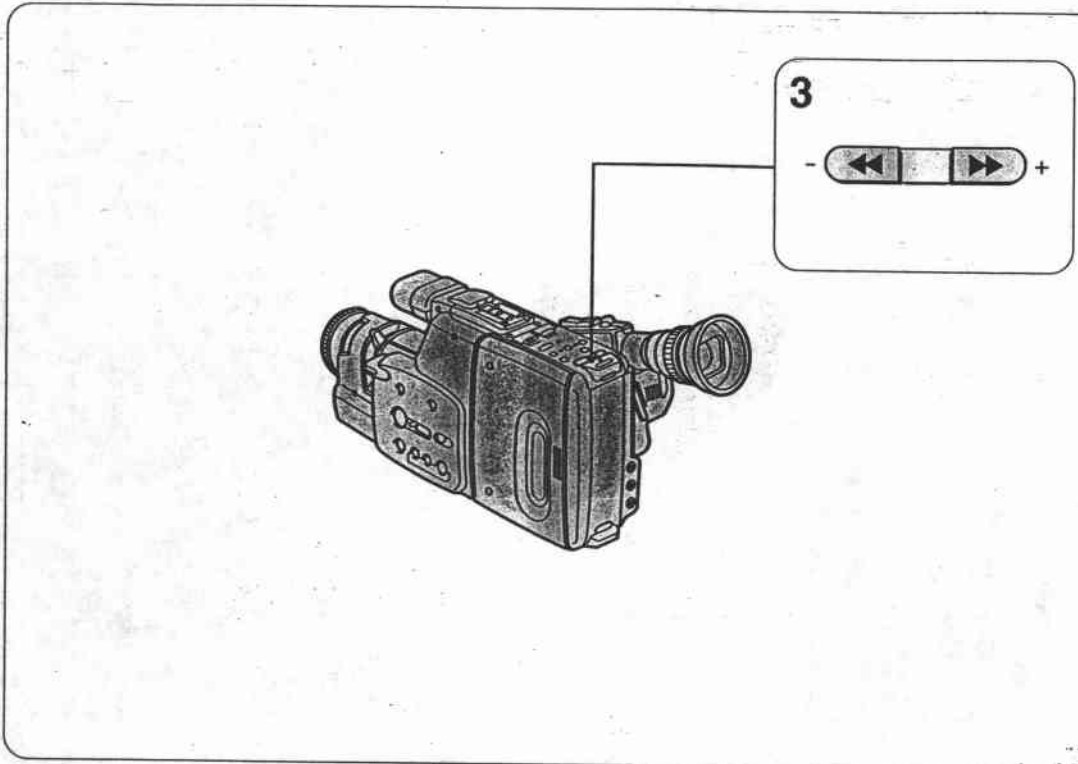

**3. Press + and - buttons to select desired mode.**

- + button moves the arrow down the list and - button moves the arrow up. **54-A**

**Self-Timer**

SELF 10-second standby and then continuous recording  
 SELF 30 10-second standby, 30-second recording and then record pause mode

**Interval Timer**

- INT.10 Recording at every 10 seconds
- INT.20 Recording at every 20 seconds
- INT.60 Recording at every 60 seconds

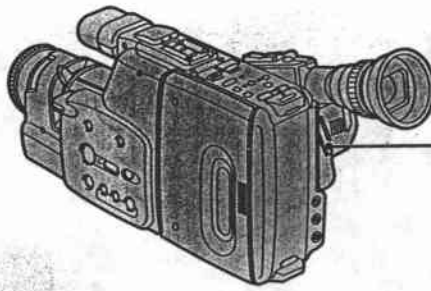

4, 5

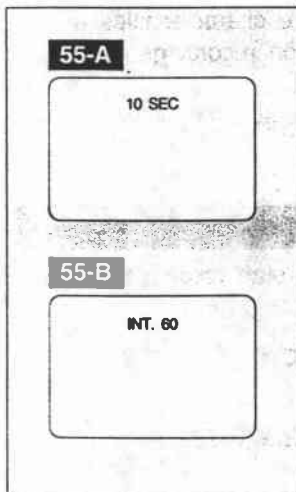

#### 4. Press start/stop button to start recording.

- Selected mode appears in viewfinder.

##### For self-timer recording: **55-A**

- Countdown 10-1 appears, followed by:  
Recording reminder display (SELF recording)  
Countdown 30-1 display (SELF 30 recording)
- Tally lamp flashes slowly during standby and flashes rapidly when recording starts.
- Recording starts automatically after countdown.

##### For interval timer recording: **55-B**

- After selected mode appears in viewfinder, standby and recording (about 0.5 seconds) are alternately performed.
- Tally lamp flashes slowly during interval timer recording.

#### 5. Press start/stop button again to stop recording.

- Camera goes into record pause mode.

#### Notes:

- Press the start/stop button to cancel self-timer recording during countdown.
- As a power source for interval timer recording, the CA-100 Compact Power Adapter or CB-110 Car Battery Adapter are better suited for the lengthy recording time that may be required.
- The camera will automatically turn off after about 6 hours of interval operation in order to protect camera parts from damage.
- Noise occasionally may occur at intervals.
- Use only SP mode for interval timer function.

# Adding Titles to Recordings (CAMERA Mode)

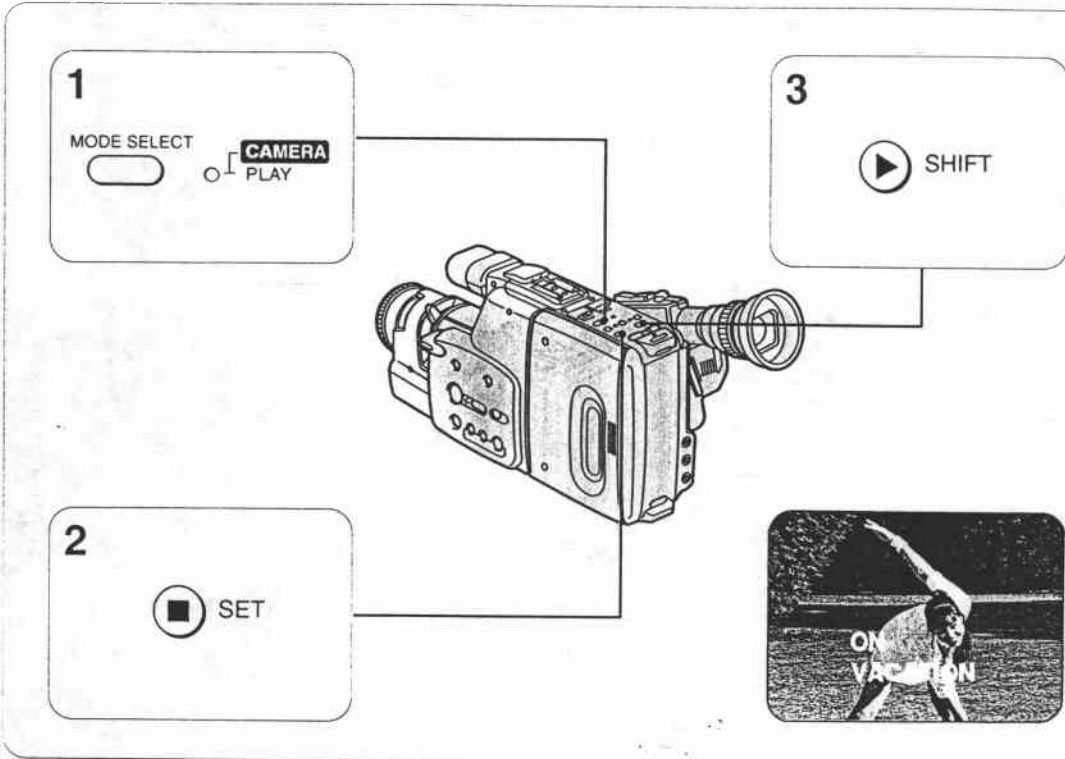

56-A

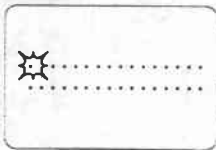

56-B

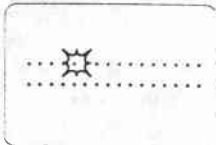

The camera allows you to create and store character titles and digital titles, which can be superimposed on recordings and displayed during playback.

Presetting character title scrolling lets you superimpose titles effectively.

## Creating Character Titles

Remember to create your title before you start recording.

The title may be one or two lines of up to 16 characters each.

### 1. Place camera in CAMERA mode.

- Mode indicator lights up red.

### 2. Press SET button to display title lines in viewfinder.

- A flashing dot or character indicates that the cursor is present. **56-A**

### 3. Press SHIFT button to move the cursor to position where you want to start the title. **56-B**

- Press once to move cursor one space right.
- Press and hold to move cursor continuously.
- Cursor does not move backwards.

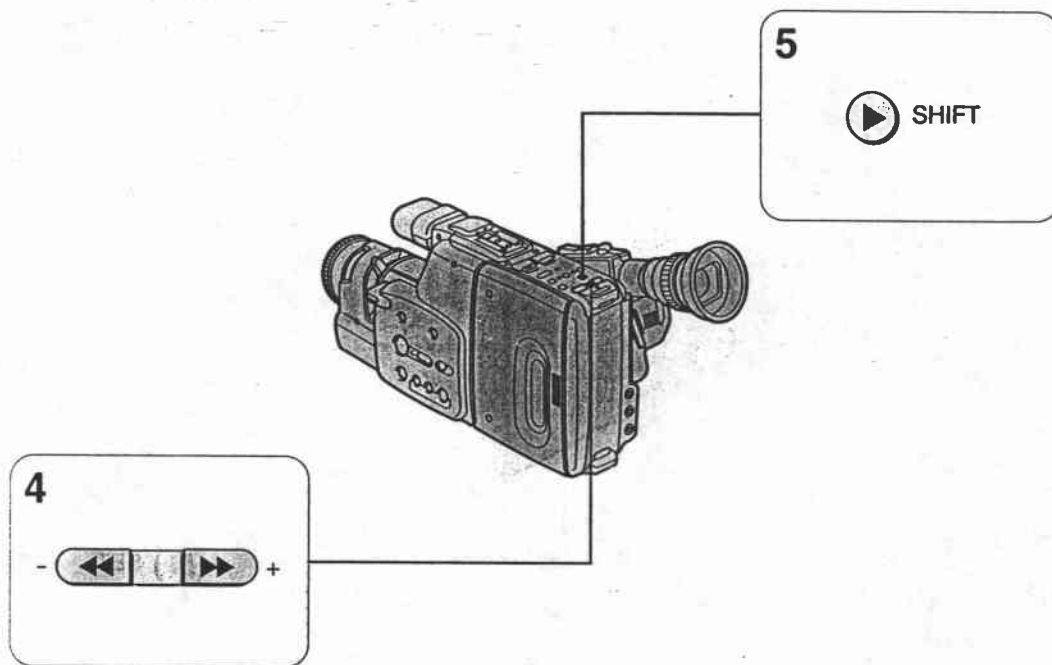

57-A

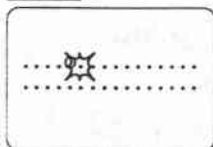

#### 4. Use + and – buttons to scan list of title characters.

- Press + button to scan forward through the list.
- Press – button to scan the list in reverse order.
- Press once to scan characters one at a time.
- Press and hold to scan characters quickly.

Title Characters List

→ ABCDEFGHIJKLMNOPQRSTUVWXYZ □  
 □ & \* ! ? ; : " ' - / . , 9 8 7 6 5 4 3 2 1 0 □ Ë Ç Ñ Æ Å Ø Ü Ö Ä ←

- If you select □, a flashing dot appears in the viewfinder, but a space will appear during actual recording and playback.
- Press both + and – buttons simultaneously to erase all characters at and to right of cursor.

#### 5. When the character you want is displayed, press SHIFT button again to move to next cursor position. 57-A

(continued on next page)

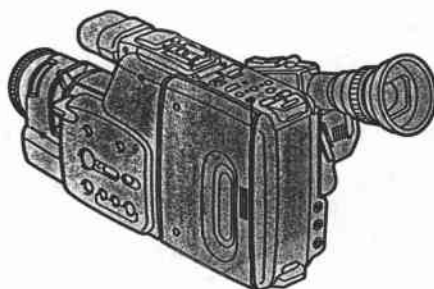

7



58-A

ON  
VACATION

**6. Follow steps 4 and 5 until your title is complete.**

- For character title scrolling, see p. 59.

**7. When the title is finished, press SET button.**

58-A

- Title is saved in camera's memory.
- Press C. TITLE button to make title disappear from viewfinder.

**Notes:**

- Title cannot be created during recording or PLAY mode.
- Character title will not be erased from memory even if the power is turned off or lithium battery is removed.
- Character titles can be displayed in PLAY mode (see pp. 77-79).

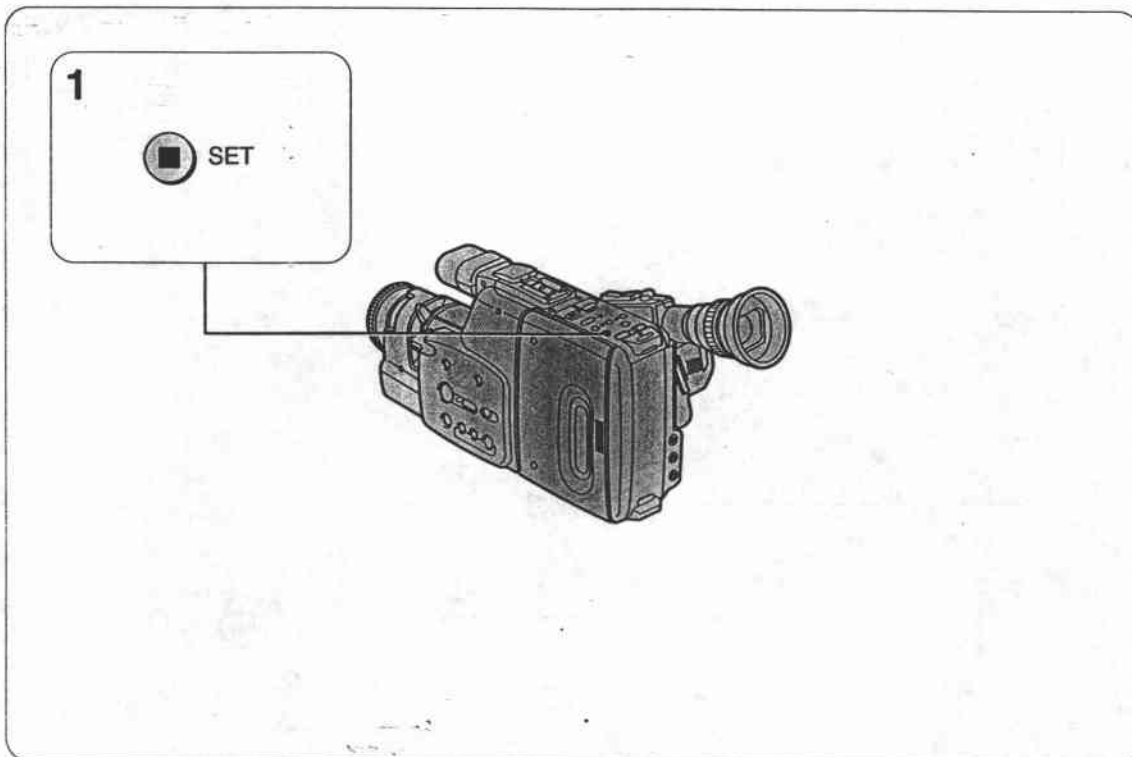

59-A



**Scrolling Character Titles**

You can preset the camera to make a character title scroll across the image during recording. Two types of scrolling are available with character titles.

**Scrolling A:** The title appears from the right side of the viewfinder, stays in the centre for 4 seconds, then disappears.

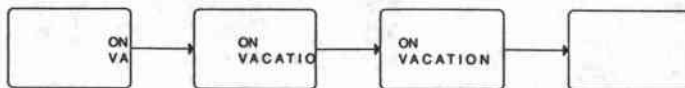

**Scrolling B:** The title appears from the right side of the viewfinder, stays in the centre for 4 seconds, then disappears to the left.

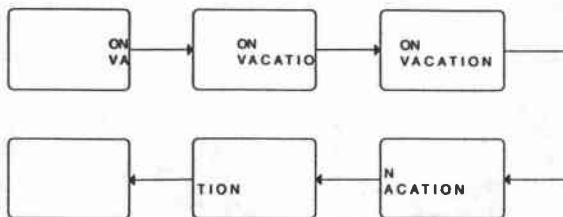

1. Press the SET button to display the character title. **59-A**

- See page 56 for creating a title.

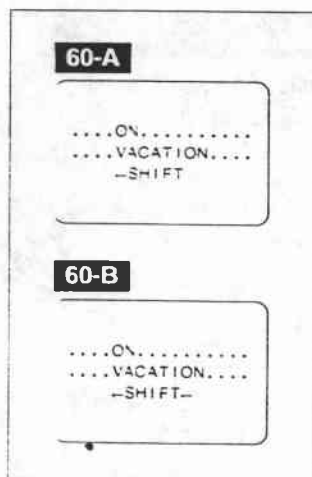
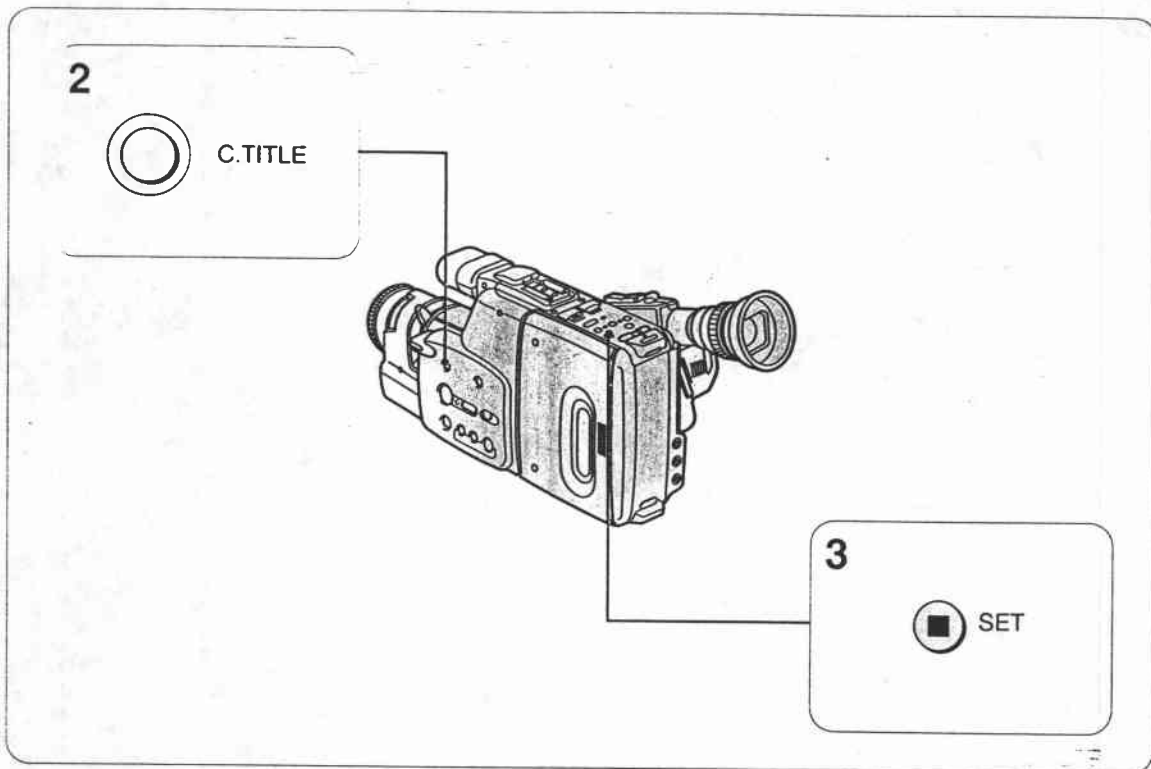

## 2. Press C. TITLE button to select the type of scrolling you want:

- For Scrolling A, press C. TITLE button once. "← SHIFT" is displayed in the viewfinder. **60-A**
- For Scrolling B, press C. TITLE button twice. "← SHIFT←" is displayed in viewfinder. **60-B**

## 3. Press SET button.

- The character title will disappear.
- When you press C. TITLE button again, the character title scrolls.

### Note:

- The setting for character title scrolling is cleared after the title has been scrolled once. If you want to scroll the title again, repeat steps 1 to 3. Note, however, that in PLAY mode the setting is not cleared after scrolling. the character title can be scrolled repeatedly.



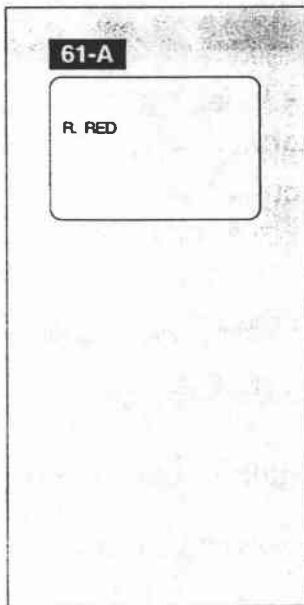
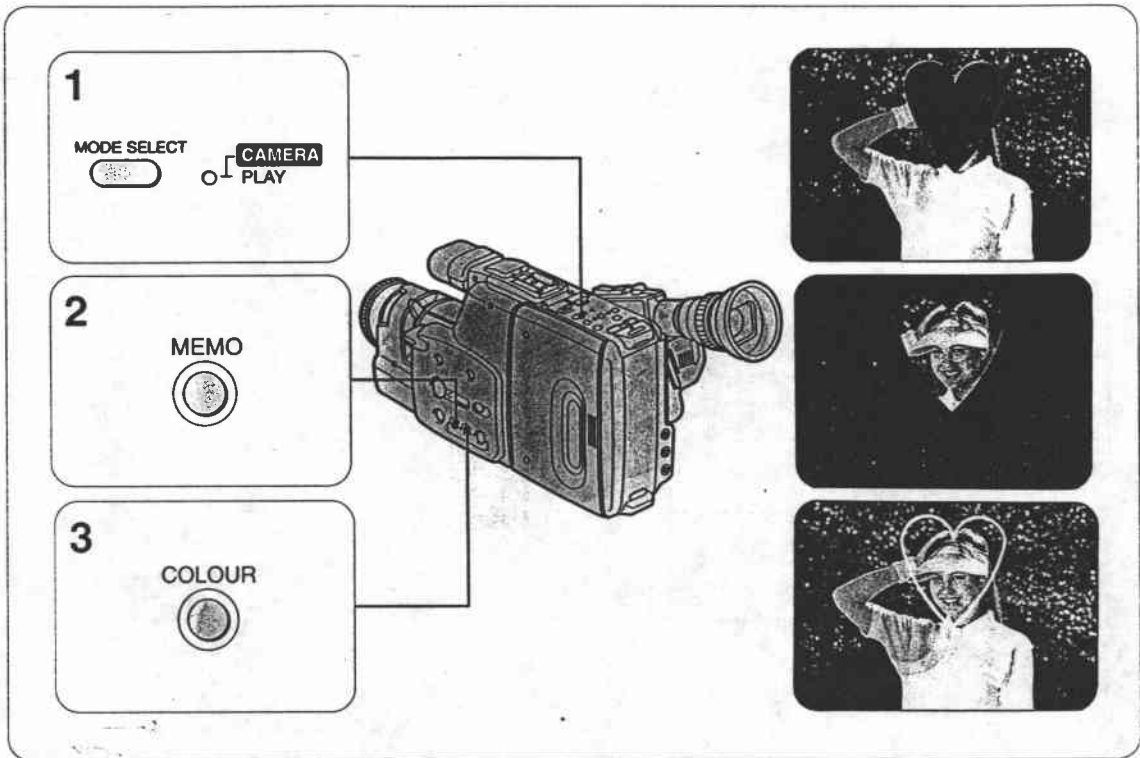

## Creating Digital Titles

Handwritten titles and illustrations can be memorized and superimposed on recordings, in a choice of 7 colours.

1. Place camera in **CAMERA** mode.
2. Frame your image and press **MEMO** button.
  - Everything within the frame will be memorized.
  - You can adjust image density (see p. 63).
3. Press **COLOUR** button to select desired colour.

### 61-A

- Choose either normal mode or reverse mode title and picture reversed in one of 7 colours, or black- or white-edged title.
- Each time **COLOUR** button is pressed, the colour display changes as shown below.



### Notes:

- Character titles can be superimposed over digital titles.
- For digital titles, your image should be thick and bold, otherwise it will appear faint, especially when using light colours such as yellow or sky blue.
- Digital titles can also be displayed in **PLAY** mode (see pp. 77-79).

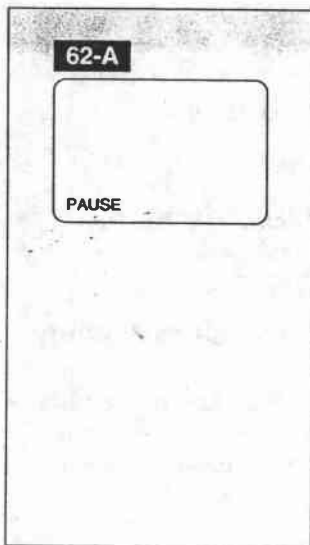
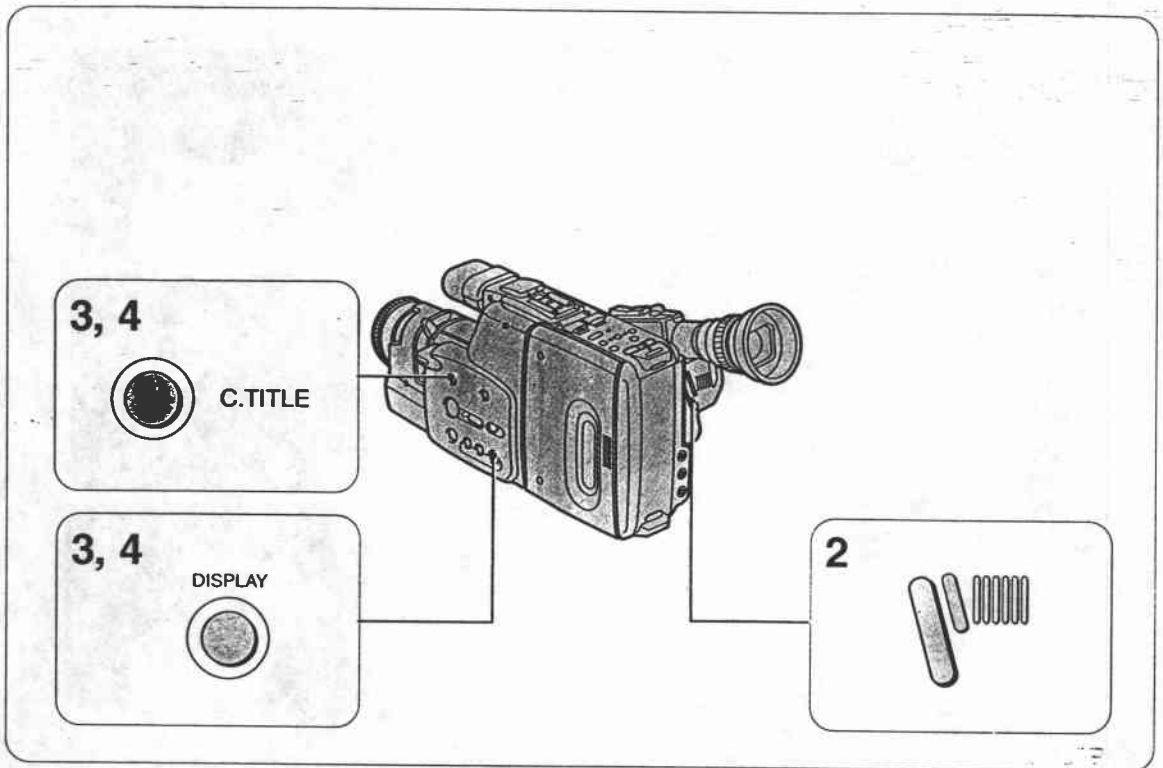

## Recording Titles

1. Place camera in record pause mode. **62-A**
2. Press start/stop button to start recording.
3. Press **C. TITLE** or **DISPLAY** button.
  - Press C. TITLE button for character title, and DISPLAY button for digital title.
  - Title appears in viewfinder.
  - Character title will scroll if you preset character title scrolling.
  - Title will be recorded with scene.
  - Reverse steps 2 and 3 if you want the title to appear right at the beginning of recording.
4. Press **C. TITLE** or **DISPLAY** button again to end title recording.
  - Title disappears from viewfinder and recording continues.

## Adjusting Image Density (Digital Title)

The camera may have difficulty memorizing images with thin lines or weak contrast. In this case, press and hold MEMO button for more than 3 seconds to adjust image density (16 levels). Levels change continuously as follows:

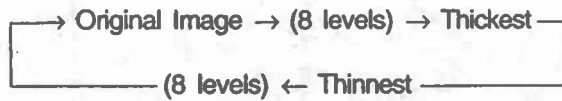

### Notes:

- Titles cannot be created during recording.
- The lithium battery allows the camera to store a digital title even when the camera is turned off. When you change or remove the lithium battery (lifetime is about one year), be sure to connect the camera to another power source first, otherwise title will be cleared from memory.
- Colour of digital title can be changed during recording.

RECORDING

# Using External Microphone and Headphones

64-A

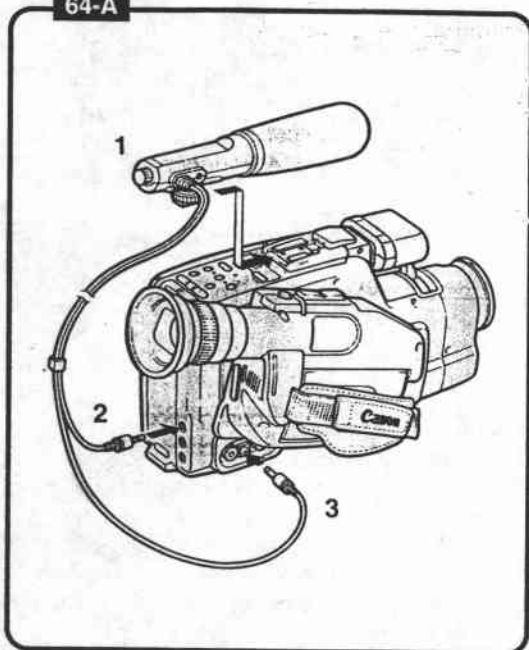

## Using External Microphone 64-A

With the optional MM-200 Stereo Mixing Microphone or the optional ZM-100 Stereo/Zoom Microphone, you can record stereo sound more effectively.

### Attaching the External Microphone

1. Slide the external microphone into accessory shoe on camera.
2. Connect the audio plug of external microphone to ST. MIC terminal on camera.
3. Connect the DC plug of external microphone to DC output terminal on camera.

### Notes:

- The optional MB-100 Microphone Boom allows you to raise the microphone away from unwanted camera noise when recording at quiet locations.
- When you use the VL-7 Battery Video Light and an external microphone at the same time, use the optional SA-1 Adapter Bracket.
- You can monitor stereo sound with commercially available headphones.
- When using a commercially available microphone, be sure it is a stereo microphone with its own power source.
- The microphone on the camcorder cannot be removed.

64-B

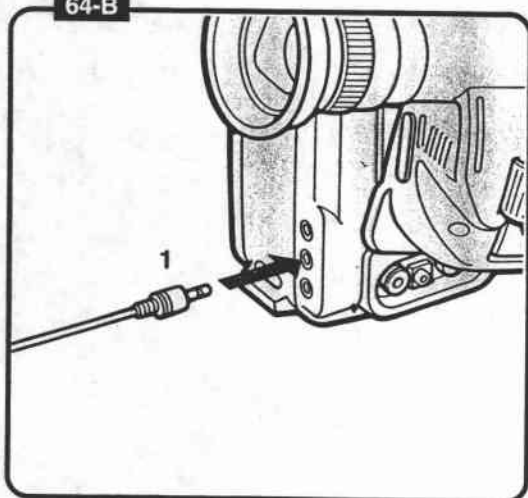

## Using Headphones 64-B

You can use commercially available stereo headphones to monitor stereo sound.

1. Connect the stereo headphones to the HEADPHONES terminal.
- Monitoring is only possible when camera is in record or record pause mode.

# Playback Connection (PLAY Mode)

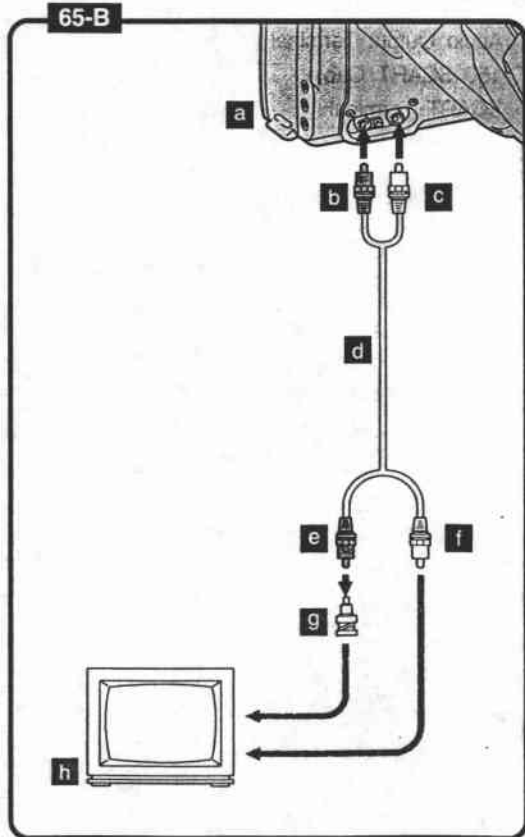
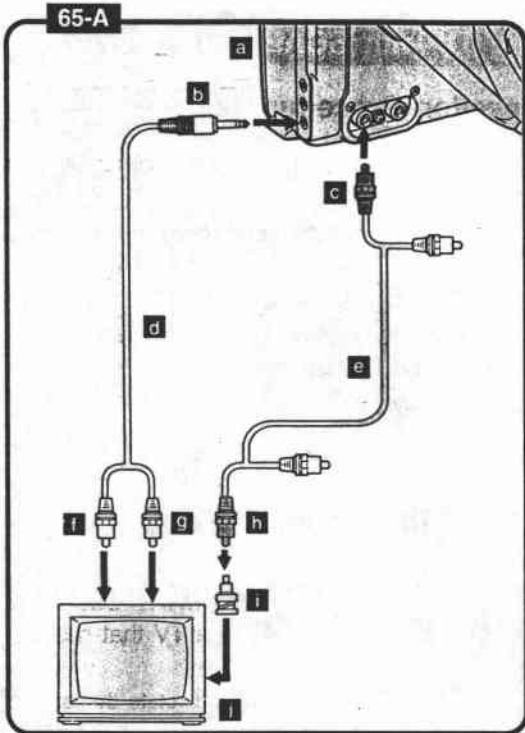

To play back a video cassette on a TV, use the DC-100 DC Coupler together with the CA-100 Compact Power Adapter (or the optional CB-110 Car Battery Adapter) or the BP-E77K Battery Pack as a power source.

- See p. 19 for details on how to connect up the DC coupler and compact power adapter (or car battery adapter).
- Playback connection depends on whether or not the TV is equipped audio/video input terminals or SCART terminal.

## Using TV with Audio/Video Input Terminals

### Connection Procedure STEREO 65-A

You need the ST-250 Stereo Cable and optional C-150 AV Cable.

- You can also use a TV connected to a VTR with audio/video input terminals.

- a Press GRIP UNLOCK button and rotate the grip upward.
- b To ST. AUDIO OUT Terminal
- c To Video Terminal (yellow)
- d ST-250
- e C-150 (video=yellow, white plug is not used)
- f To Audio Input Terminal (left-white)
- g To Audio Input Terminal (right-red)
- h To Video Input Terminal (yellow)
- i BNC Adapter\*
- j TV: Set TV / VIDEO selector to VIDEO

### Connection Procedure MONAURAL

#### 65-B

You need the optional C-150 AV Cable.

- You can also use a TV connected to a VTR with audio/video input terminals.

- a Press GRIP UNLOCK button and rotate the grip upward.
- b To Video Output Terminal (yellow)
- c To Audio Output Terminal (black)
- d C-150 (video=yellow, audio=white)
- e To Video Input
- f To Audio Input
- g BNC Adapter\*
- h TV: Set TV/VIDEO selector to VIDEO

PLAYBACK

- For TV or VTR which has a BNC-type video input terminal, use a commercially available BNC plug adapter for connection.

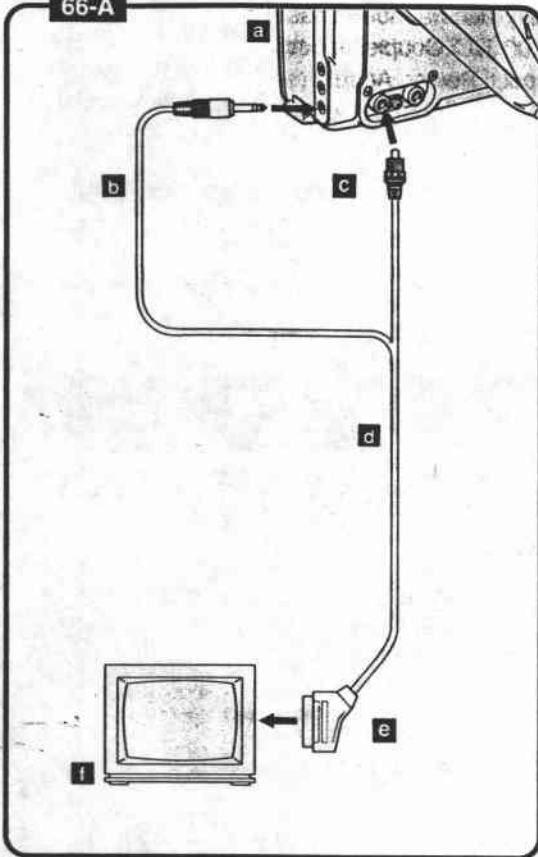
**66-A**

## Using TV with SCART Terminal

### Connection Procedure STEREO **66-A**

You need the optional PC-370ST Stereo SCART Cable and a power source for playback on a TV that has SCART terminal.

- a** Press GRIP UNLOCK button and rotate the grip upward.
- b** To ST. AUDIO OUT Terminal
- c** To Video Terminal (yellow)
- d** PC-370ST Stereo SCART Cable
- e** To SCART Terminal
- f** TV

### Connection Procedure MONAURAL

**66-B**

You need the optional PC-150 SCART Cable and a power source for playback on a TV that has SCART terminal.

- a** Press GRIP UNLOCK button and rotate the grip upward.
- b** To Video Output Terminal (yellow)
- c** To Audio Output Terminal (black)
- d** PC-150 SCART Cable
- e** To SCART Terminal
- f** TV

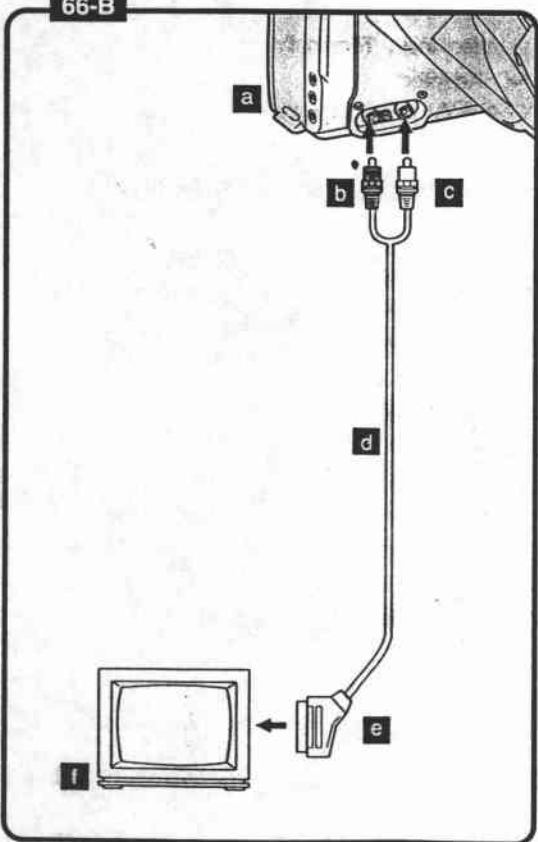
**66-B**

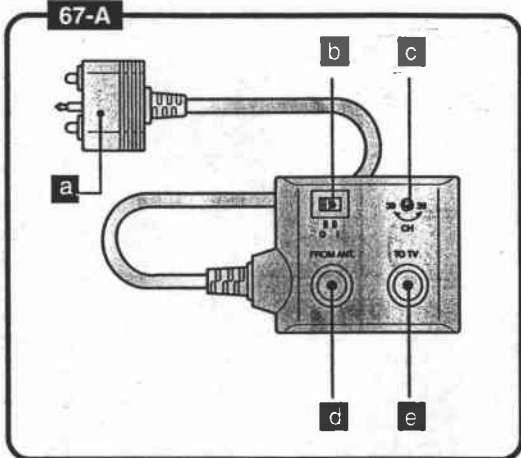

The RU-100 RF Unit is required in order to view recorded video cassette on a TV which does not have audio/video input terminals. There are two models of RU-100, one for Europe and one for Australia. The connection and setting procedures for the two models differ. On a TV without audio/video input terminals E250 play back in monaural.

### Using TV without Audio/Video Input Terminals (European Model)

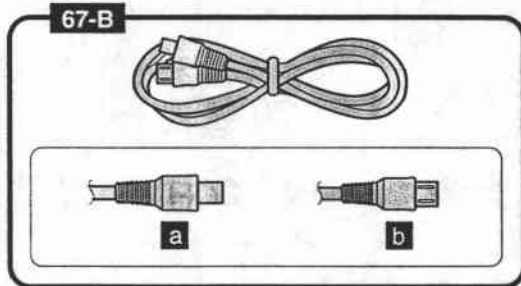

#### RU-100 67-A

- a Connection Plug
- b G/I Selector
- c Video Channel Selector
- d FROM ANT. Terminal
- e TO TV Terminal

#### Coaxial Cable with DIN-connectors 67-B

- a male
- b female

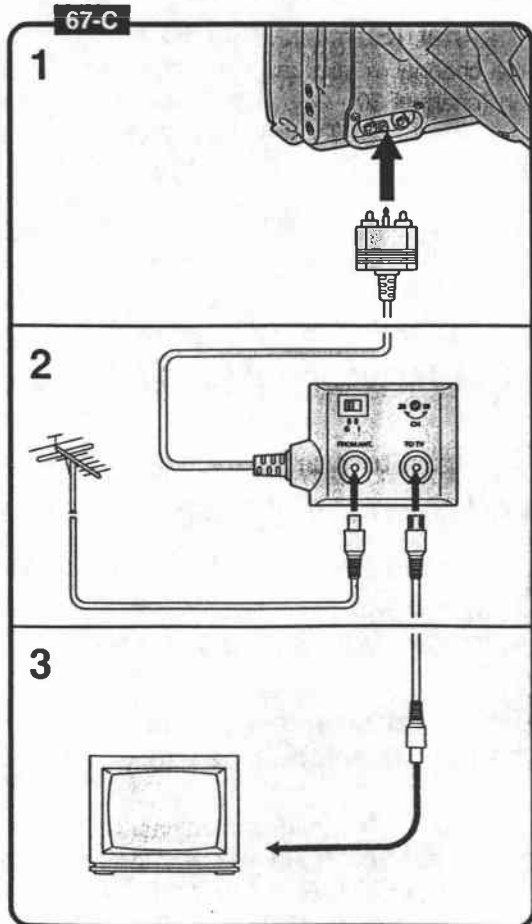

#### Connection Procedure 67-C

1. Connect RF Unit to camera.
2. Attach aerial cable to FROM ANT. terminal, and connect female connector to TO TV terminal of RF unit.
  - Please note the difference between 'male' and 'female' type DIN-connectors on coaxial cable.
3. Connect male connector to aerial input of TV.

#### To View a Regular TV Programme

The RU-100 RF Unit has an automatic signal selector which selects the signal from the video camera whenever the camera is connected to the RF unit and the power is turned on. To view a regular TV programme, disconnect the camera from the RF unit, or turn the camera off.

PLAYBACK

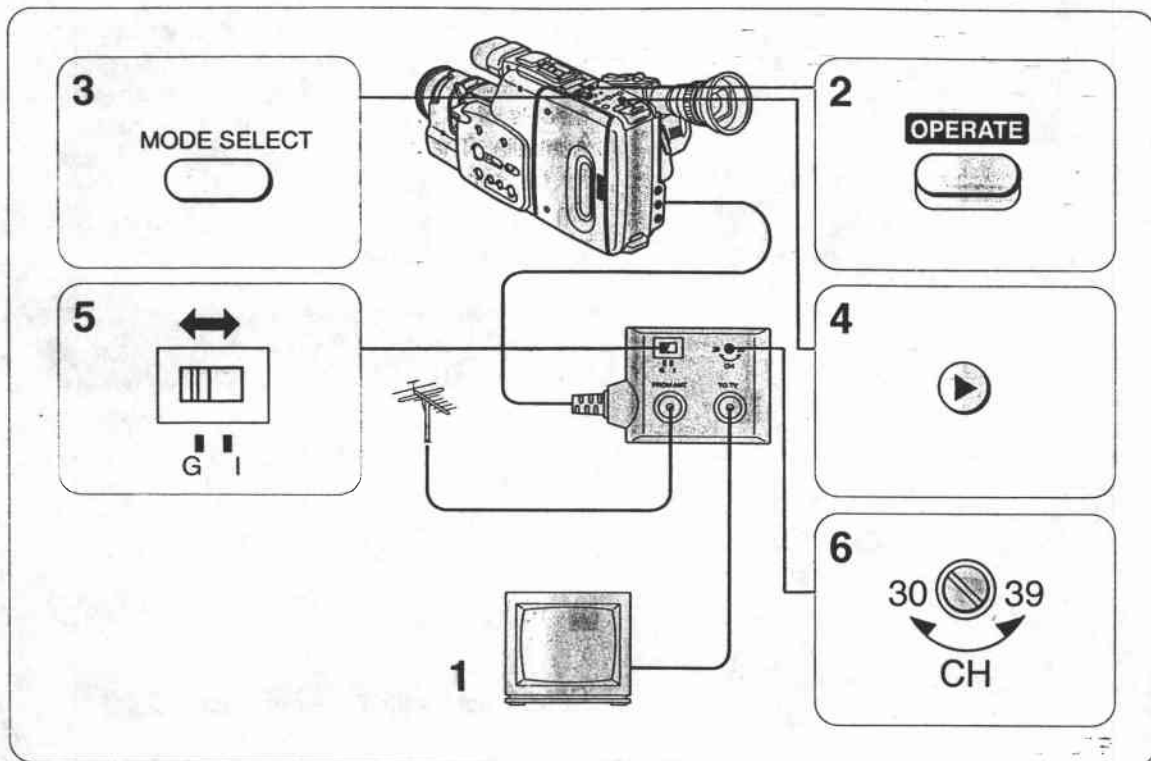

### Selecting Video Channel (European model)

Video channel means the channel in your area which is not used by a broadcasting station (channel 30 - 39). If your TV does not have audio/video input terminals, your TV set and the video channel selector of the RU-100 RF Unit must be set to the video channel in order to view playback.

1. Turn TV on.
2. Turn camera on.
3. Press **MODE SELECT** button to select **PLAY** mode.
4. Press **▶ (PLAY)** button to start playback.
5. Set RF unit's **G/I** selector using flat-edge screwdriver.
  - G: Continental Europe
  - I: England, South Africa, Hong Kong
  - If G/I selector is set improperly, picture will appear, but no sound will be heard.
6. Set TV and video channel selector to video channel (video channel selector is factory-set to CH 32).
  - For example, if video channel in your area is channel 33, turn TV to channel 33, then use a flat-edge screwdriver to set video channel selector of RU-100 to CH 33. Adjust by turning until picture is clear.



## Using TV without Audio/Video Input Terminals (Australian Model)

### RU-100 69-A

- a Connection Plug
- b Video Channel Selector
- c TO TV Terminal
- d FROM ANT. Terminal

### Coaxial Cable with DIN-connectors 69-B

- a male
- b female

### Connection Procedure 69-C

1. Connect RF Unit to camera.
2. Attach aerial cable to FROM ANT. terminal, and connect female connector to TO TV terminal of RF unit.
  - Please note the difference between 'male' and 'female' type DIN-connectors on coaxial cable.
3. Connect male connector to aerial input of TV.

PLAYBACK

### To View a Regular TV Programme

The RU-100 RF Unit has an automatic signal selector which selects the signal from the video camera whenever the camera is connected to the RF unit and the power is turned on. To view a regular TV programme, disconnect the camera from the RF unit, or turn the camera off.

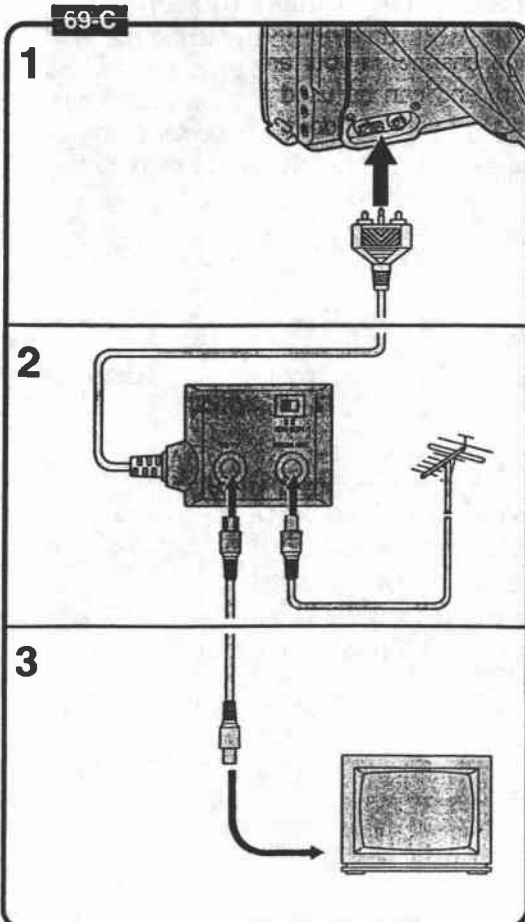
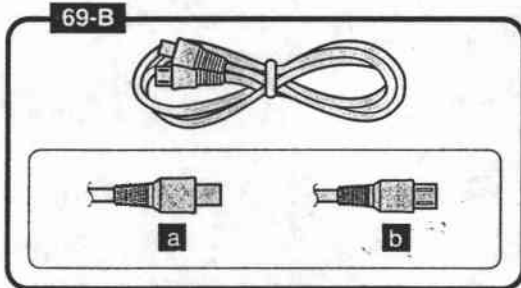
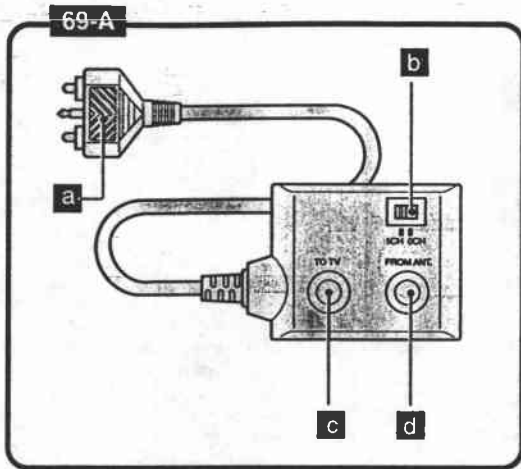

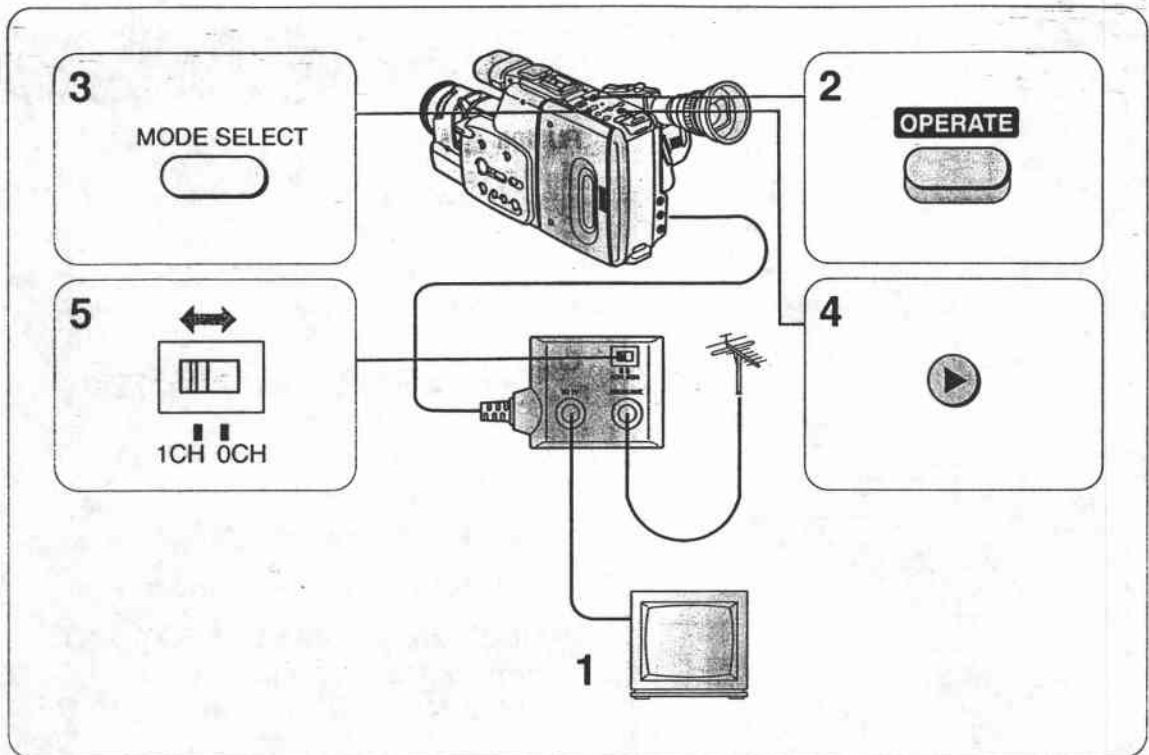

### Selecting Video Channel (Australian model)

Video channel means the channel in your area which is not used by a broadcasting station, and can be used for playback of video cassettes (channel 0 or 1). If your TV does not have audio/video input terminals, your TV and the video channel selector of the RU-100 RF Unit must be set to the video channel in order to view playback.

1. Turn TV on.
2. Turn camera on.
3. Press **MODE SELECT** button to select **PLAY** mode.
4. Press **▶ (PLAY)** button to start playback.
5. Set TV and video channel selector to video channel (video channel selector is factory-set to 1CH) using a flat-edge screwdriver.
  - For example, if video channel in your area is channel 0, set video channel selector of RU-100 to 0CH, then tune TV to channel 0.

# Playback Procedure (PLAY Mode)

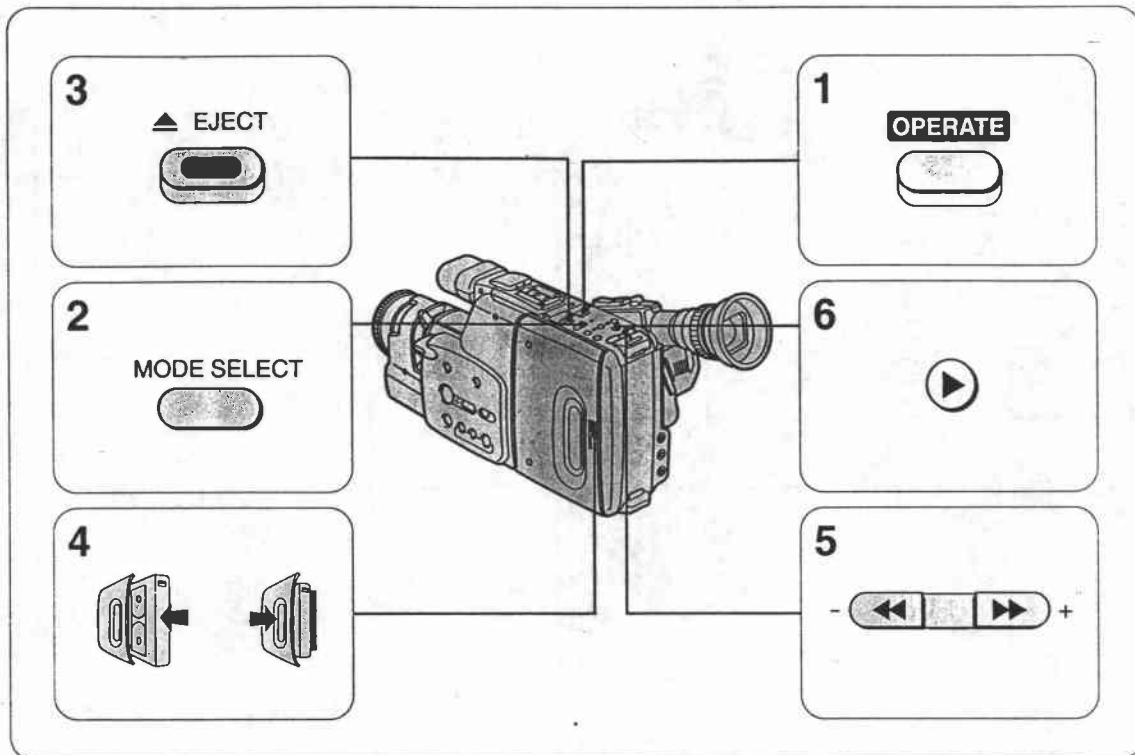

PLAYBACK

- 1. Turn camera on.**
  - Mode indicator lights up red.
- 2. Press MODE SELECT button to select PLAY mode.**
  - Mode indicator changes from red to green.
  - You must complete step 2 to commence playback.
- 3. Press EJECT button.**
  - Video cassette compartment opens.
- 4. Load video cassette in camera and close video cassette compartment.**
- 5. Locate playback start point.**
  - Use ◀◀(REW) or ▶▶(FF) buttons to locate start point or use high-speed search (see p. 74).
- 6. Press ▶ (PLAY) button to start playback.**
  - You can also monitor playback in viewfinder.

(continued on next page)

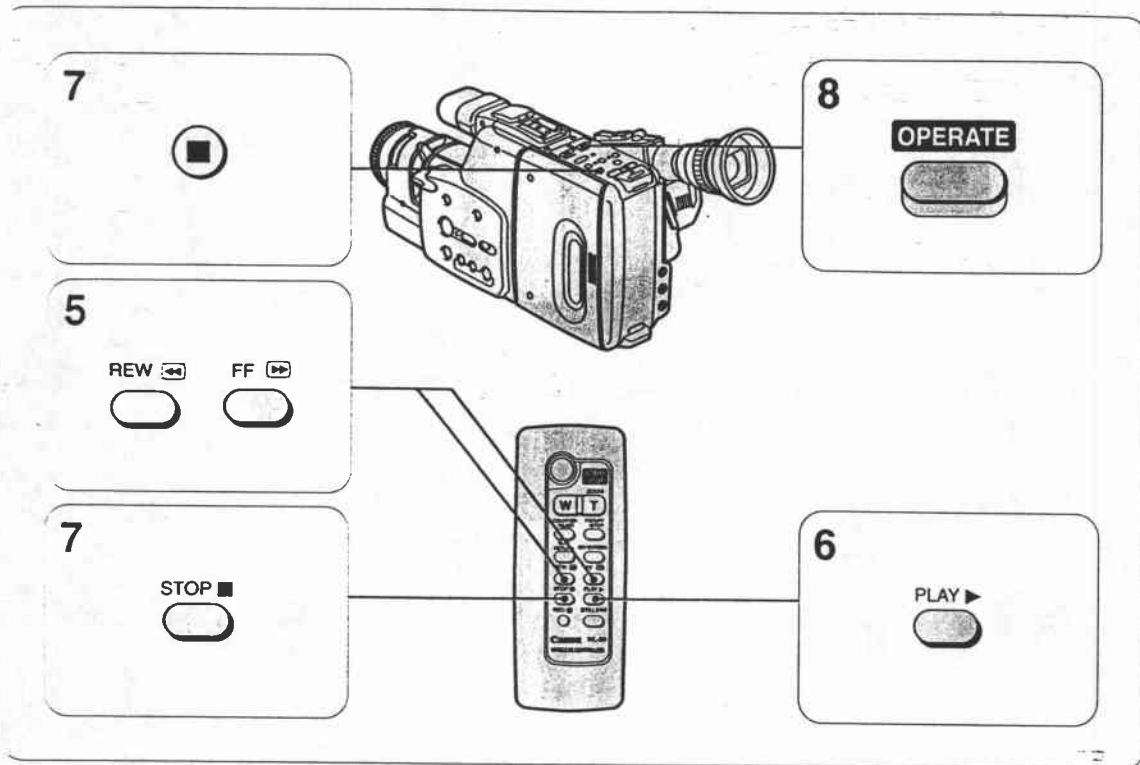

7. Press ■ (STOP) button to end playback.

8. Turn camera off.

- Mode indicator (green) goes off.

### PLAY Mode

Press MODE SELECT button once to select the PLAY mode.

- Mode indicator lights up green.

In PLAY mode, the 4 buttons on the top of the camera have the functions indicated in blue. Use these buttons or the wireless controller to play back a video cassette.

To select the CAMERA mode, press MODE SELECT button again or turn camera off then on (the mode indicator lights up red).

### High-Frequency Feedback

- High-frequency feedback may occur if camera microphone is too close to the TV speaker (only during recording or record pause mode). Lower TV volume.

# Special Playback Methods (PLAY Mode)

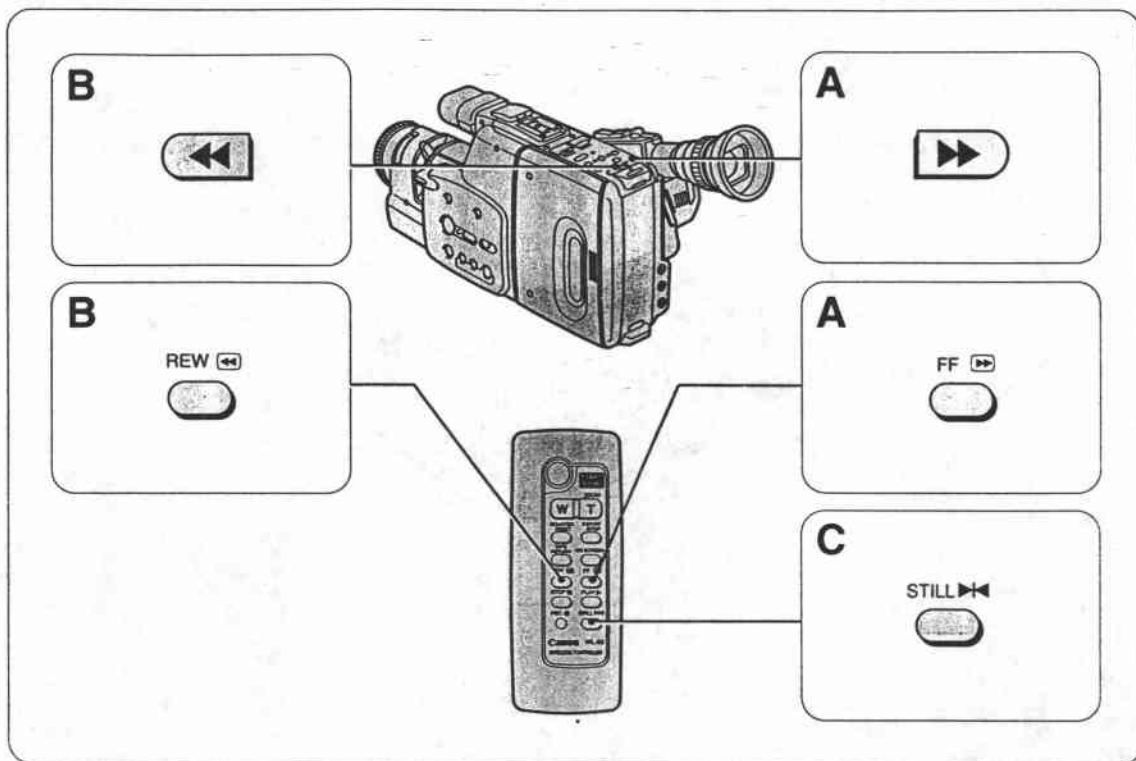

PLAYBACK

In addition to normal playback, your camera also has fast forward, rewind and still playback, plus high-speed search. Playback is controlled by pressing buttons on the camera or by using the wireless controller.

## A. Fast Forward Playback

Press and hold ►► (FF) button during normal playback to view scenes at 9 times normal speed.

- Release ►► (FF) button to resume normal playback.

## B. Rewind Playback

Press and hold ◀◀ (REW) button during normal playback to view scenes in reverse at 7 times normal speed.

- Release ◀◀ (REW) button to resume normal playback.

## C. Still Playback

Press STILL button on the wireless controller during normal playback to pause the picture. Press STILL button again or ► (PLAY) button to resume normal playback.

- Camera does not have a STILL button. Use the wireless controller for still playback.

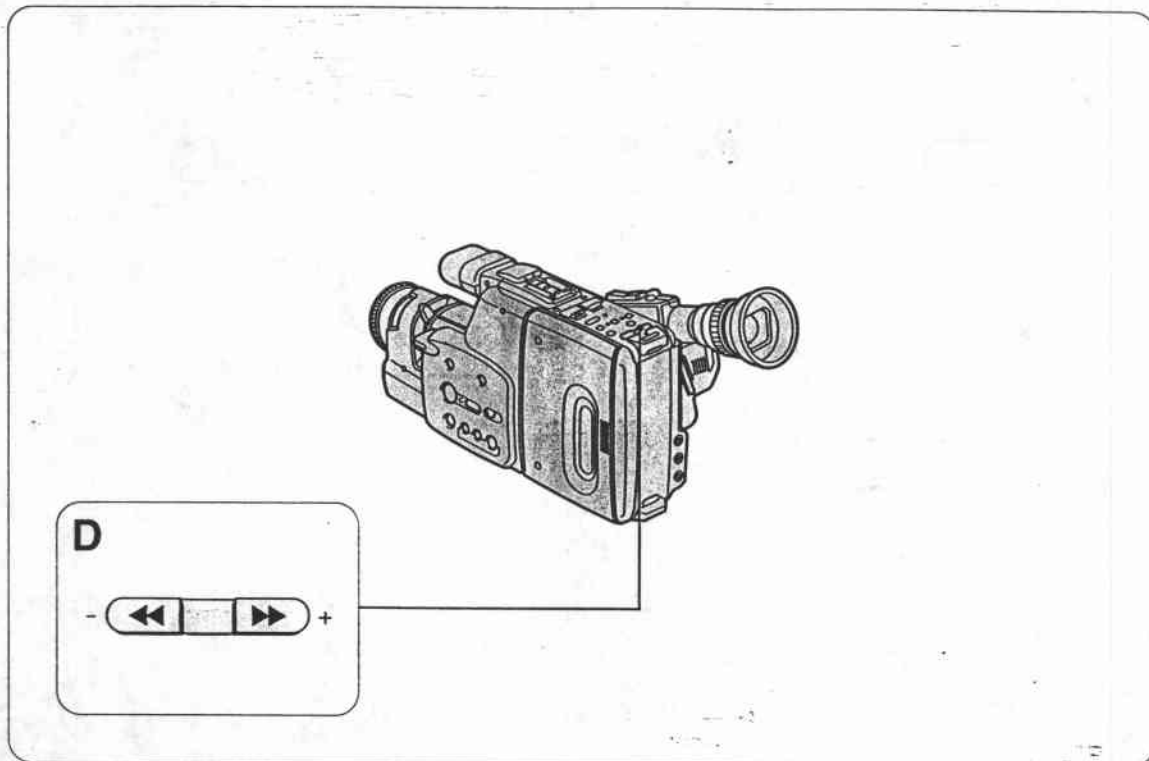

#### D. High-Speed Search

Press ►► (FF) button once during normal fast forward mode to view scenes at approximately 15 times (SP) or 30 times (LP) normal speed. Press ►► (FF) button again to resume normal fast forward.

Press ◀◀ (REW) button once during normal rewind mode to view scenes in reverse at approximately 15 times (SP) or 30 times (LP) normal speed. Press ◀◀ (REW) button again to resume normal rewind.

- You can also operate high-speed search by pressing and holding ►► (FF) button/◀◀ (REW) button during normal fast forward or rewind. Release the button to resume normal fast forward or rewind.

75-A



75-B



**Notes:**

- Several noise bars appear during special playback.  
During fast forward and rewind playback modes. **75-A**  
During still playback. **75-B**
- Audio portion of tape cannot be heard during special playback.
- The camera automatically goes into stop mode after more than 7 minutes of continuous still playback.
- The picture flickers a little during still playback.
- When fast action scenes are shown during still playback, the picture may blur.
- Certain TVs may show the special playback picture in black and white, or the picture may roll or divide.
- Notes about special playback of tapes recorded in SP:
  - (1) The still playback picture will contain much more noise than for tape recorded in LP.
  - (2) During fast forward or rewind playback, noise bars will be much wider than for a tape recorded in LP.
- The high-speed search picture might not appear on some TVs.

# Tape Return (PLAY Mode)

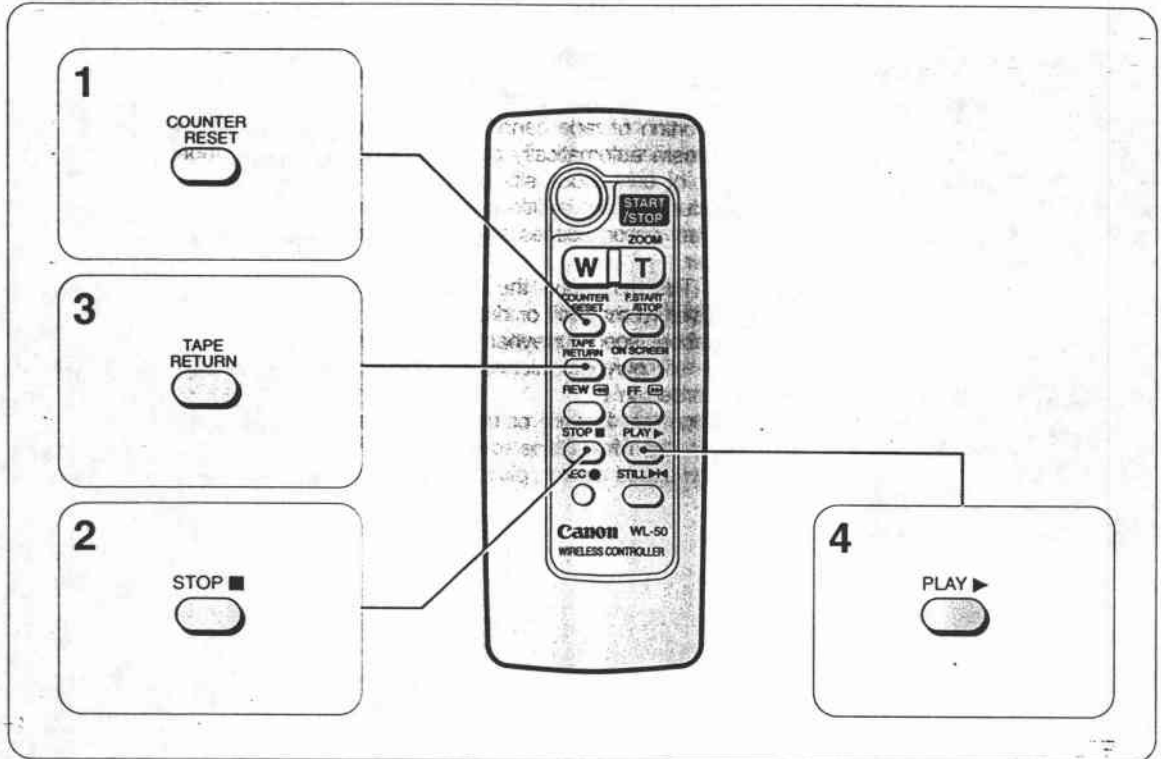

Tape return allows you to quickly return to a desired scene on the video cassette.

- Camera does not have a TAPE RETURN button. Use the wireless controller to operate tape return.

1. When you locate a scene during playback that you want to watch again later, press **COUNTER RESET** button.
  - Tape counter resets to 0:00:00. **76-A**
2. Press **■ (STOP)** button when playback finishes.
3. Press **TAPE RETURN** button.
  - Tape rewinds and stops automatically when counter reading reaches near 0:00:00.
4. Press **▶ (PLAY)** button.
  - Playback starts at the spot where you pressed **COUNTER RESET** button.

## Notes:

- Every time you load a video cassette, the tape counter automatically resets to 0:00:00. This means that after recording you can use the tape return function to locate the recording start point.
- Tape counter reading is only approximate. Use it as a guide.
- Tape return does not function when initial tape counter reading is near 0:00:00.
- Press STOP button to cancel tape return.



# Editing to Another VTR (PLAY Mode)

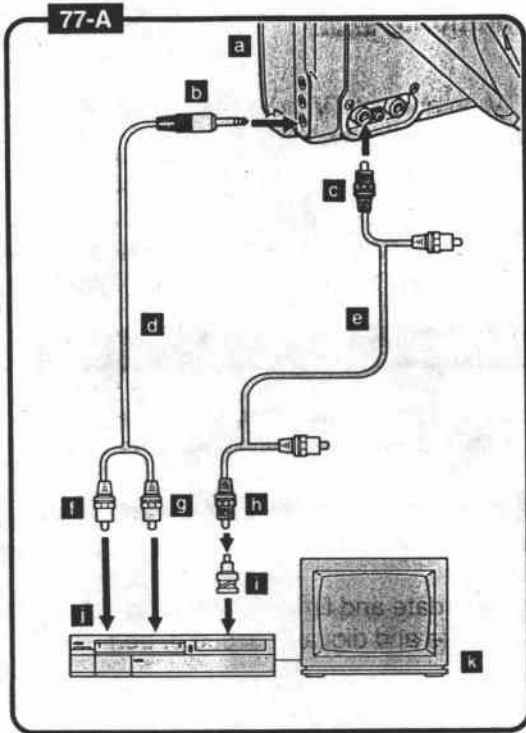

With the help of a second VTR, your camera can also be used as a playback VTR to edit your recording.

## Connection Procedure STEREO 77-A

You need the DC-100 DC Coupler, CA-100 Compact Power Adapter (or optional CB-110 Car Battery Adapter), ST-250 Stereo Cable and optional C-150 AV Cable for connection.

- If the second VTR has a SCART terminal, use the optional PC-370ST Stereo SCART Cable for connection.

- a** Press GRIP UNLOCK button and rotate the grip upward.
- b** To ST. AUDIO OUT Terminal
- c** To Video Terminal (yellow)
- d** ST-250
- e** C-150 (video=yellow, white plug is not used)
- f** To Audio Input Terminal (left-white)
- g** To Audio Input Terminal (right-red)
- h** To Video Input Terminal (yellow)
- i** BNC Adapter (commercially available)
- j** Second VTR (Recording)
- k** TV

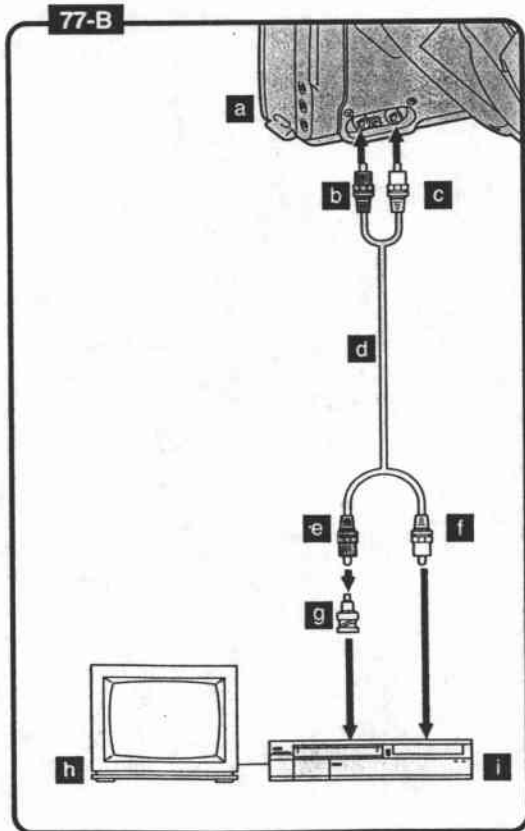

## Connection Procedure MONAURAL

77-B

You need the DC-100 DC Coupler, CA-100 Compact Power Adapter (or optional CB-110 Car Battery Adapter) and optional C-150 AV Cable for connection.

- If the second VTR has a SCART terminal, use the optional PC-150 SCART Cable for connection.

- a** Press GRIP UNLOCK button and rotate the grip upward.
- b** To Video Output Terminal (yellow)
- c** To Audio Output Terminal (black)
- d** C-150 (video=yellow, audio=white)
- e** To Video Input Terminal
- f** To Audio Input Terminal
- g** BNC Adapter (commercially available)
- h** TV
- i** Second VTR (Recording)

EDITING

78-A

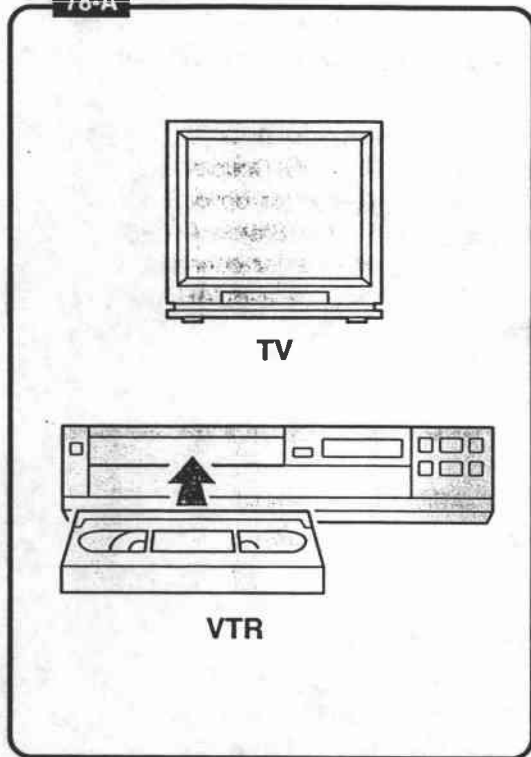

## Preparations **78-A**

### TV

Turn TV on and set TV to video channel or set TV/VIDEO selector to VIDEO.

### VTR

Turn on second VTR and load a recordable video cassette. See VTR instruction manual for details.

## Adding Titles

You can superimpose date, time, character titles and digital titles during playback, and record them on another VTR.

Press DATE, C. TITLE or DISPLAY button during recording on another VTR.

(For setting date and time, see p. 21; for creating character title and digital title, see p. 56.)

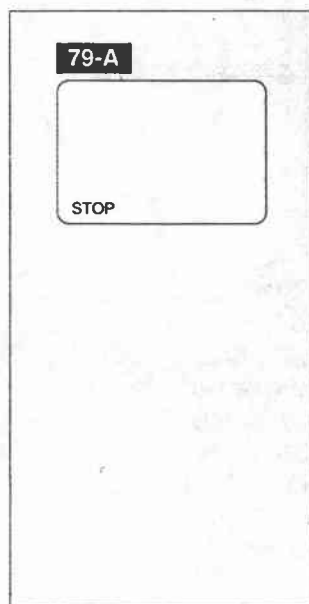
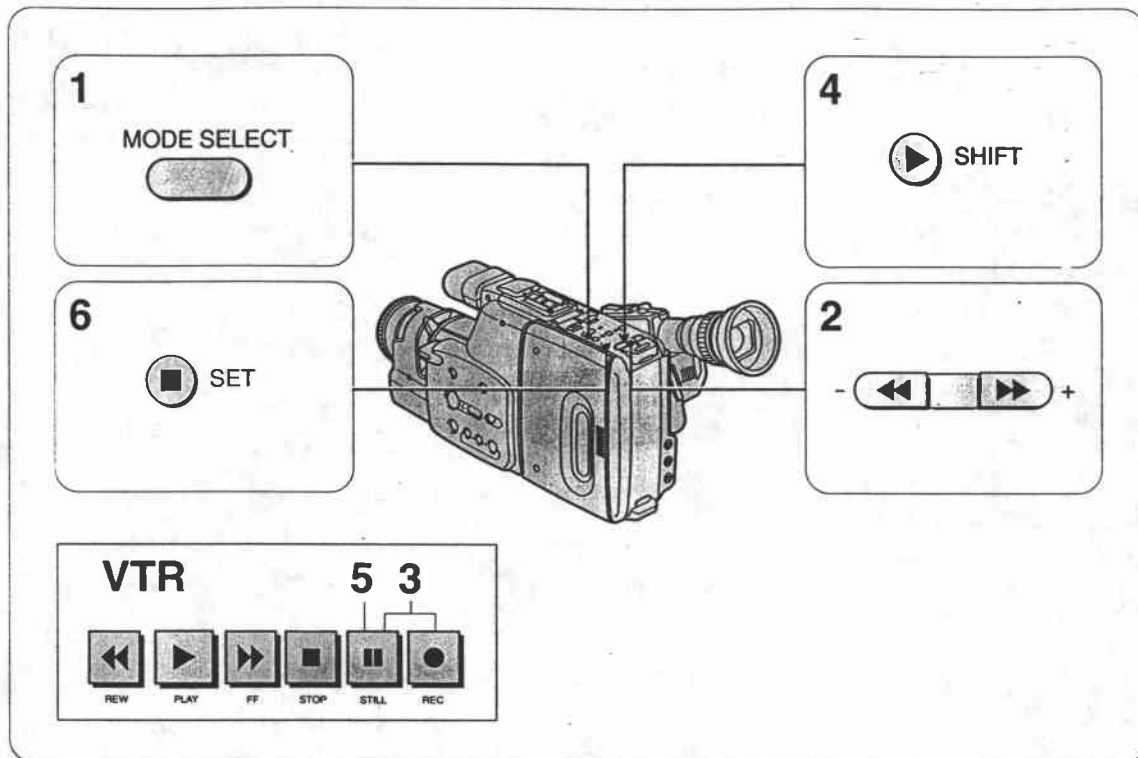

### Editing Procedure

1. Press **MODE SELECT** button to select **PLAY** mode. **79-A**
2. Locate a point slightly before editing start point on video cassette in camera.
3. Place second VTR in record pause mode.
4. Press camera **▶ (PLAY)** button.
  - Check playback picture on TV screen.
5. Release second VTR from record pause mode at **editing start point**.
  - Recording begins on second VTR.
  - You can superimpose the date, time, character titles and digital titles.
6. Press **■ (STOP)** buttons on camera and second VTR to end editing.

EDITING

**Note:**

- Both image and sound quality of edited tape will be somewhat less than that of the original.

# Canon E250 Video System Chart

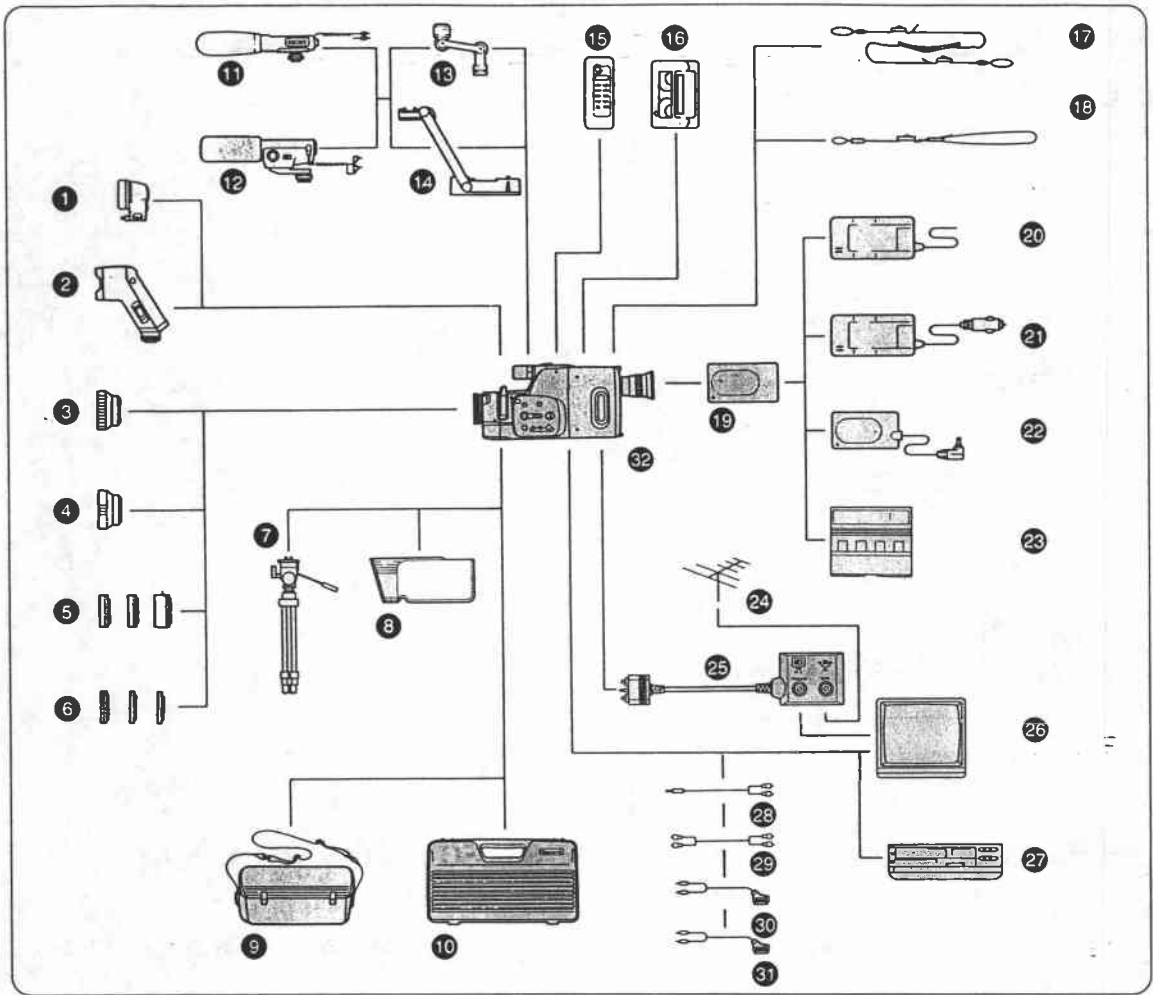

- ① VL-7 Battery Video Light
- ② VL-20 Battery Video Light
- ③ WD-37 Wide-converter
- ④ TL-37 Tele-converter
- ⑤ FS-37 Filter Set
- ⑥ FS-37U Filter Set
- ⑦ Tripod
- ⑧ RS-60 Rain Shield
- ⑨ SC-800 Soft Carrying Case
- ⑩ HC-60 System Case
- ⑪ MM-200 Stereo Mixing Microphone
- ⑫ ZM-100 Stereo/Zoom Microphone
- ⑬ MB-100 Microphone Boom
- ⑭ SA-1 Adapter Bracket
- ⑮ WL-50 Wireless Controller
- ⑯ 8mm Video Cassette

- ⑰ SS-300 Shoulder Strap
- ⑱ WS-20 Wrist Strap
- ⑲ BP-E77K or BP-E722 Battery Pack
- ⑳ CA-100 Compact Power Adapter
- ㉑ CB-110 Car Battery Adapter
- ㉒ DC-100 DC Coupler
- ㉓ MC-100 Multi-battery Charger
- ㉔ Aerial
- ㉕ RU-100 RF Unit
- ㉖ TV
- ㉗ VTR
- ㉘ ST-250 Stereo Cable
- ㉙ C-150 AV Cable
- ㉚ PC-150 SCART Cable
- ㉛ PC-370ST Stereo Scart Cable
- ㉜ E250

# Carrying Cases

SC-800

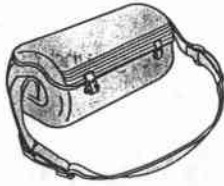

## SC-800 Soft Carrying Case

The optional SC-800 Soft Carrying Case provides lightweight protection for the camera and accessories.

HC-60



## HC-60 System Case

The optional HC-60 System Case safely stores and helps protect the camera and its accessories during transportation and storage.

The HC-60 properly stores the following items:

- ① One additional 8mm video cassette
- ② Two battery packs
- ③ Camera with video cassette and shoulder strap / wrist strap attached
- ④ Coaxial cable or C-150/PC-150 Cable
- ⑤ CA-100 Compact Power Adapter or CB-110 Car Battery Adapter
- ⑥ DC-100 DC Coupler
- ⑦ WL-50 Wireless Controller
- ⑧ VL-7 Battery Video Light
- ⑨ RU-100 RF Unit
  - Wide-converter / Tele-converter, etc.

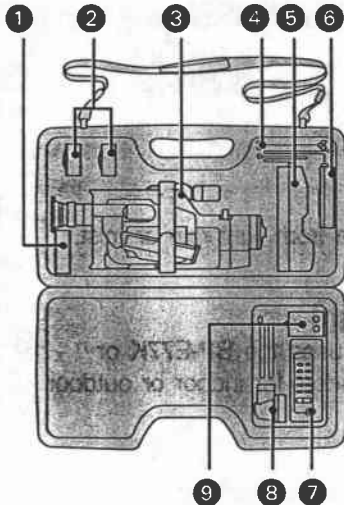

### Opening the Case

Slide the latches on both sides of the case as illustrated to open.

- Open case with "UP" sticker pointing upward.

### Attaching Shoulder Strap

Attach shoulder strap to the strap attachment bars, and adjust it to the most comfortable length.

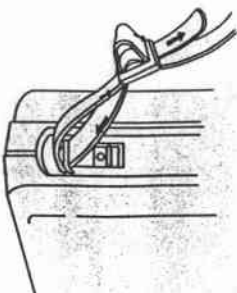
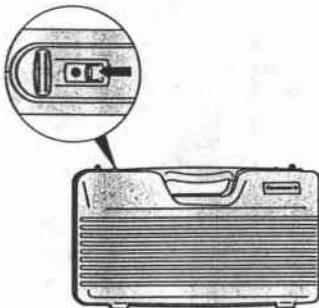

### Notes:

- Do not leave case in areas of extreme heat.
- Do not expose case to strong vibrations or shock.
- Do not place heavy objects on top of case.
- Two keys are provided with the HC-60 System Case.
- Power is slowly drained while the battery pack is attached to the camera, even when the camera is turned off. Remove the battery pack when you don't expect to use the camera.

# Optional Accessories

CB-110

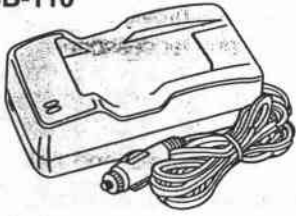

## CB-110 Car Battery Adapter

For recording using car battery.

Plug into cigarette lighter socket.

For use only with 12 or 24 V DC negative ground car battery.

BP-E722

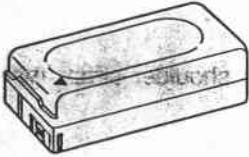

## BP-E722 Battery Pack

Used for lengthy recording, its capacity is double the

BP-E77K. Hold the camera with both hands when using this battery.

MC-100

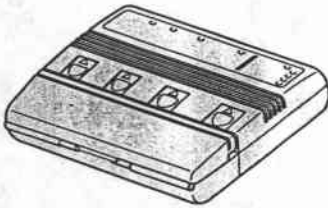

## MC-100 Multi-battery Charger

MC-100 Multi-battery Charger is sequential high-speed charger controlled by a microcomputer for charging up to four Canon battery packs. Also the MC-100 automatically performs charging, discharging and recharging to refresh battery packs.

- Charging time: 45 min. (BP-E77K)  
90 min. (BP-E722)

RS-60

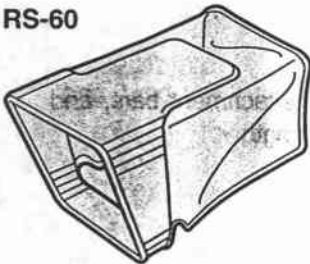

## RS-60 Rain Shield

A vinyl cover to protect camera from light rain or mist.

VL-20



## VL-20 Battery Video Light

This light, compact video light uses the BP-E77K or BP-E722 Battery Pack and is ideal for indoor or outdoor shooting.

TL-37

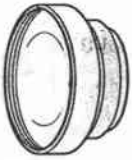

WD-37

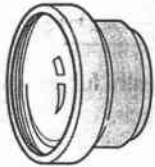

FS-37



FS-37U

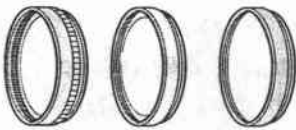

MM-200

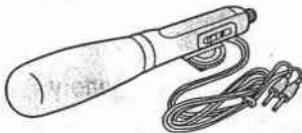

ZM-100

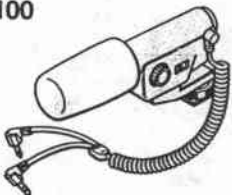

MB-100

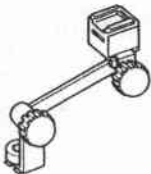

SA-1

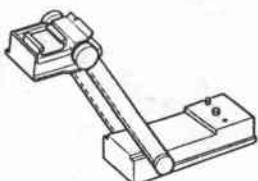

### TL-37 Tele-converter

This tele-converter is a magnification converter lens that increases the focal length of the camera lens by a factor of 1.4. You can use the zoom function with this lens attached.

### WD-37 Wide-converter

This wide converter decreases the focal length by a factor of 0.75. You can use the zoom function with this lens attached.

### FS-37 Filter Set

FS-37 Filter Set contains 3 filters: multiple image filter 5X, R-cross filter 6X and zoom-spot filter.

### FS-37U Filter Set

FS-37U Filter Set contains 3 filters: UV, ND8 and circular PL.

- When using the PL Filter, first zoom and switch to manual focus. Then adjust the PL Filter to minimize light reflection.

### MM-200 Stereo Mixing Microphone

This stereo mixing microphone allows background music and sound effects to be recorded from a headphone stereo.

### ZM-100 Stereo/Zoom Microphone

This stereo/zoom microphone offers 2 functions: stereo and zoom. When using the stereo function, you can adjust the angle of sound recording. When using the zoom function, you can adjust recording sensitivity in order to record nearby or far away sounds.

### MB-100 Microphone Boom

This microphone boom raises the microphone away from unwanted camera noise when recording in quiet locations.





### SA-1 Adapter Bracket

When you want to use the VL-7 Battery Video Light and an external microphone at the same time, use the SA-1 to attach the microphone to the camera.

# Problems and Troubleshooting

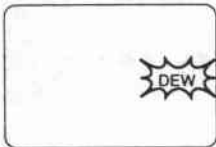
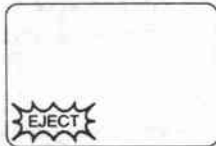
Use the following checklist for troubleshooting when you have problems with your camera. Consult your local dealer or service outlet if problems persist. Be sure all connections are properly made when using the camera with other units.

The following warnings may appear in viewfinder:

Warning	Cause	Remedy
	Battery pack charge is low.	Replace with fully charged battery pack.
	Condensation (DEW) has formed inside unit.	Refer to Condensation (see p. 87).
	Safety mechanism is activated.	Unload and reload video cassette.
	Lithium battery is not in place properly or charge is low.	Insert new lithium battery (see p. 20).
	Video cassette is not loaded.	Load a video cassette.
	Erasure prevention switch on the video cassette is set to prevent recording.	Use another video cassette or set switch to enable recording (see p. 30).



<b>Problem</b>	<b>Cause</b>	<b>Remedy</b>
Camera does not turn on.	Battery pack charge is low.	Replace with fully charged battery pack.
Camera turns off during operation (using battery pack).	Battery pack charge is low.	Replace with fully charged battery pack.
	Record pause mode has lasted for more than 7 minutes.	Turn camera on again.
Video cassette compartment does not open.	Battery pack charge is low.	Replace with fully charged battery pack.
Camera does not function when an operation button is pressed.	Camera is turned off.	Turn camera on.
	Video cassette is not loaded.	Load a video cassette.
	Battery pack is not properly attached to the camera.	Attach battery pack securely to the camera (see p. 16).
Start/stop button is pressed, but recording does not start.	Camera is turned off.	Turn camera on.
	Video cassette is not loaded.	Load a video cassette.
	Tape has ended ("T. END" appears in viewfinder).	Rewind tape or use another video cassette.
	Erase prevention switch on the video cassette is set to prevent recording ("TAPE" flashes in viewfinder).	Use another video cassette or set switch to enable recording (see p. 30).
	Camera is in PLAY mode.	Press MODE SELECT button.
No picture appears in viewfinder.	Lens cap is attached.	Remove lens cap.
	Camera is in PLAY mode.	Press MODE SELECT button.
Cannot adjust focus.	Zooming lever is in macro range.	Move zooming lever into normal focusing range.
	Viewfinder diopter is not properly adjusted.	Turn diopter adjustment ring until viewfinder display becomes clear (see p. 27).
	Autofocus window is obscured.	Remove obstacle from autofocus window.
Playback doesn't start when ► (PLAY) button is pressed.	Camera is in CAMERA mode.	Press MODE SELECT button.
	Camera is turned off.	Turn camera on and press MODE SELECT button.
	Video cassette is not loaded.	Load a video cassette.
	Tape has ended ("T. END" appears in viewfinder).	Rewind tape or use another video cassette.

ADDITIONAL INFORMATION

Problem	Cause	Remedy
Tape is moving, but no picture appears on TV monitor.	For TV without audio/video input terminals: Video channel not set properly on both TV and RF unit.	Set TV and RF unit to appropriate video channel.
	For TV with audio/video input terminals: TV/VIDEO selector on TV not set to VIDEO.	Set TV/VIDEO selector to VIDEO.
	Video heads are dirty.	Clean video heads using the optional CK-E1 Cleaning Kit.
The video light will not turn on.	DC-100 DC Coupler is attached to the camera.	Remove DC-100 DC Coupler and attach BP-E77K or BP-E722 (option) Battery Pack.
	The battery pack is exhausted.	Charge the battery pack.
	Either the camera or the video light is not turned on.	Turn on both the camera and the video light.
	The bulb has burned out.	Replace the bulb.
	No video cassette.	Insert video cassette and place camera in record pause or record mode.
	Camera is not in record pause or record mode.	Place camera in record pause or record mode.

**86-A**



### Smear **86-A**

A luminous bar appears vertically on the screen where an excessively bright scene was recorded.

Smear is caused when:

- Spotlights are directly recorded, on a stage for example.
- Burning candles or other burning objects are recorded directly.
- Objects reflecting light, such as car bodies and traffic signs, are recorded directly.

**86-B**



### Poor playback picture on TV monitor **86-B**

Loss in video playback picture quality such as blurring, distortion or noise usually means that the video heads have become dirty. Use the optional Canon 8mm Video Head Cleaning Cassette CC-8 included in the Canon 8mm Video Cleaning Kit CK-E1 to clean video heads. See CC-8 instruction manual for details.

#### Note:

- This equipment contains a microprocessor. If external noise or interference occurs, random letters may appear in the viewfinder or normal operation may be interrupted. In this case, remove power source (and if necessary, remove the lithium battery) and then replace in the unit.

# Condensation (DEW)

87-A

A



B

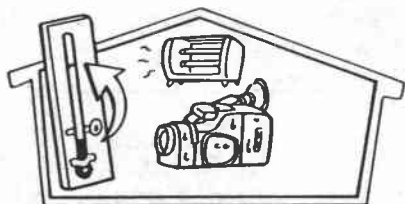

C



D



## What is condensation?

Condensation (DEW) means tiny droplets of water that occasionally form on the camera surface when it is moved from a cold place to a warm place. Using the camera when condensation is present may damage both tape and camera.

## Condensation is likely to occur when:

87-A

- Camera is brought from a cold place to a warm place.
- A cold room is heated rapidly.
- Camera is taken from an air-conditioned room to a warm and humid place.
- Camera is placed in a humid environment.

## Preventing condensation

Remove video cassette and place the camera in a plastic bag prior to bringing it into a warm area where condensation is likely to occur. Wait until the camera reaches room temperature before removing it from the bag.

## When condensation is detected

When condensation is detected in the camera, the mode indicator flashes, "DEW" flashes in the viewfinder and the tape automatically stops.

87-B

Immediately remove video cassette, leave video cassette compartment open and turn camera off. Leave the camera in a dry place until condensation evaporates.

- Sometimes "DEW" may not appear in the viewfinder until 10-15 minutes after condensation has formed.

## To start using camera again

Even when "DEW" and the mode indicator no longer flash when the camera is turned on, wait at least one more hour before attempting operation. The time required for condensation to clear varies with surrounding conditions; it can be as long as 1 hour.

87-B



MODE SELECT



CAMERA



PLAY

# Cautions

A



B

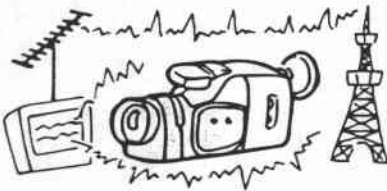

C



D

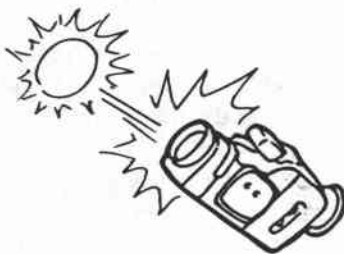

E

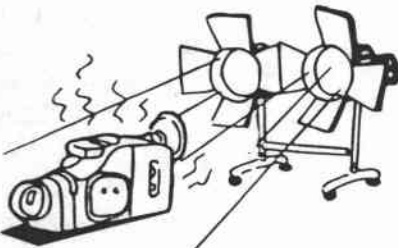

## During Use

### A. Avoid High Temperatures and High Humidity.

Do not expose the camera to high temperatures or high humidity, such as inside a car during hot weather, when all the doors and windows are shut. Such exposure can cause damage.

### B. Avoid Exposure to Strong Electromagnetic Waves.

Do not use the camera close to sources of magnetic or electric fields (power plant, TV tower, TV set, magnets, motors, audio equipment, etc.)

### C. Do Not Expose the Camera to Rain or Water.

Place protective covering over the camera if you'll be recording in the rain, to reduce the risk of fire or electric shock. If, somehow, water does get into the camera, contact qualified service personnel as soon as possible.

### D. Avoid Pointing the Lens into Direct Sunlight or Other Strong Light Sources.

Do not aim the lens directly at the sun or other strong light, or leave the lens aimed at a very bright subject since this can cause damage.

### E. Do Not Expose the Camera to Excessive Heat:

When using lighting equipment be sure not to expose the camera to too much heat radiating from such equipment.

**F****F. Always Replace the Lens Cap.**

Always replace the lens cap after use to prevent sand and dust from getting on the lens. Be especially careful to affix the cap on windy days.

**G****G. Do Not Expose the Camera to Shock or Vibrations.**

Be sure to handle the camera gently. Vibration or shock can cause damage.

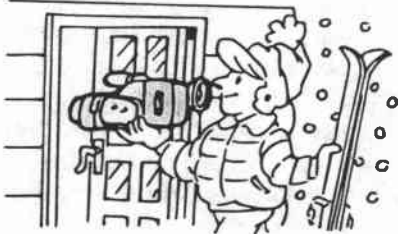
**H****H. Avoid Sudden Changes in Temperature.**

If the camera is suddenly brought into a warm place from a cold place, condensation can form on the internal parts and lens. So take appropriate care when moving the camera.

**I****I. Do Not Disassemble the Camera.**

It is very dangerous to disassemble the camera or touch any of its internal parts, as you may risk electric shock or other hazards. If the camera does not function properly, take it to qualified service personnel.

**J****J. Using the Battery Pack and Recommended Accessories.**

Carefully read the instructions that come with the battery pack before use. And to reduce the risk of electric shock and to reduce annoying interference, use the recommended accessories only.

## **Using Your Battery Packs Effectively**

### **Immediately After Purchase**

Newly purchased battery packs have not been charged, so charge completely before using.

When charging brand new battery packs, charge until charge indicator lights, and disconnect. Then reconnect and charge a second time.

### **General Use**

Battery packs can be charged when ambient temperature is between 0°C—40°C. Best results are achieved between 10°C—30°C.

After battery pack has been fully charged, do not continue to try to recharge it. Repeatedly recharging a fully charged battery pack can cause it to become overcharged.

Repeatedly recharging battery pack before it is fully discharged will cause its electrical storage capacity to decrease (charge memory). In such cases, discharge battery pack completely by waiting until camera's mode indicator goes out, or by using optional VL-20 Battery Video Light until it grows dim. Indicator will go out after it begins to flash (unless video light is attached), and battery pack can then be removed.

When using battery pack with the battery video light, be sure to disconnect battery pack when the light begins to grow dim. Continuing to use battery pack in such a situation may cause it to be discharged below specified level.

Immediately after use, battery pack will be hot and it is best not to recharge it at this time. Make sure that battery pack has cooled off before recharging.

When battery pack has been discharged below specified level, you may be unable to recharge it completely (battery pack will not recharge fully even though charge indicator lights). In such a case, charge and discharge battery pack repeatedly (2—3 times) until it is recharged properly.

## **Storage**

When battery pack is connected to the camera, it will continue to discharge even when the power is turned off, and this may cause it to become discharged below specified level. Disconnect battery pack from camera when storing.

When storing the battery pack for a long period of time, choose a cool, chemically stable location. Allow it to discharge completely by connecting it to the camera and waiting until mode indicator goes out (about 10 minutes after it begins to flash).

If battery pack has been stored for 3 months or longer, a single recharging will not be sufficient to restore it to full operability. In such a case, completely recharge and completely discharge battery pack 2—5 times. This will restore it to its original capacity.

## **Terminology**

Overcharging and discharging below specified level will cause battery pack to function less effectively, and shorten its life.

### ***Overcharging:***

Charging battery pack after it has already been fully charged.

### ***Discharging below specified level:***

Continuing to discharge battery pack after its voltage level has fallen below a specified level (5.0 V for the nickel-cadmium batteries used by Canon 8mm video camcorder).

### ***Charge memory:***

When a nickel-cadmium battery is discharged only partially (not long enough for charge to cut off automatically), and then recharged and used again, continuous recording time decreases. The battery pack will be temporarily incapable of discharging to final voltage level.

## **Maintenance**

### **Keep the Heads Clean.**

The video heads should be cleaned only when necessary, preferably with the Canon 8mm Video Head Cleaning Cassette CC-8 included in the Canon 8mm Video Cleaning Kit CK-E1.

### **Clean the Camera with a Soft, Dry Cloth.**

The camera should be cleaned using a soft, dry cloth. Do not use chemically treated cloth or volatile solvent such as paint thinner, since this can damage the unit.

### **Store the Camera Properly.**

If you do not intend to use the camera for some time, store it in an area free of moisture and dust, and where the ambient temperature is no higher than 30°C.

### **Store Cassette Tape Properly.**

Do not place video cassettes in areas exposed to direct sunlight, near heat-radiating sources such as stoves, or close to magnetic bodies such as speakers, since these can cause tape deformation and damage to valuable recordings.

### **Check the Operation of Each Component.**

If the camera has not been used for a long time, be sure to check that each component functions correctly before use.



# Specifications

## E250

<b>Power supply (rated):</b>	6 V DC
<b>Power consumption:</b>	7.2 W (during recording in autofocus mode)
<b>Television system:</b>	CCIR standard (625 lines, 50 fields) PAL colour signal
<b>Video recording system:</b>	2 rotary heads, helical scanning system Luminance signal: FM azimuth recording Colour signal: Converted subcarrier phase shift recording (8mm video standard)
<b>Audio recording system:</b>	Frequency multiplexing with the video signal by 2 rotary heads (2 channels)
<b>Image sensor:</b>	320,000-pixel, 1/3-inch CCD (Charge Coupled Device)
<b>Tape format:</b>	8mm, metal particle*
<b>Tape speed:</b>	20.051 mm/s (SP) 10.026 mm/s (LP)
<b>Maximum recording time:</b>	3 hours with P5-90 video cassettes, in LP mode.
<b>Lens</b>	f/2.2, 12X power zoom, 6.7–80.4 mm focal length, macro mechanism (wide/tele)
<b>Focusing system:</b>	Active autofocus, manual focusing possible
<b>Minimum focusing distance:</b>	0.7 m or 4mm in wide macro
<b>Minimum illumination:</b>	3 lux (in gain-up mode)
<b>Recommended illumination:</b>	More than 100 lux
<b>Filter diameter:</b>	37 mm
<b>Electronic viewfinder:</b>	0.6-inch monochrome CRT
<b>Microphone:</b>	Stereo electret condenser microphone
<b>Input level:</b>	Audio: -64 dBV/600 ohms, unbalanced (external mic)
<b>Output level:</b>	Video: 1 V <sub>p-p</sub> /75 ohms, unbalanced (video output terminal) Audio: -10 dBV/less than 3 k ohms, unbalanced (audio output terminal)
<b>Dimensions: (W x D x H)</b>	110 x 305 x 125 mm
<b>Weight:</b>	980 g excluding battery pack and video light

## RF Unit RU-100

	European model	Australian model
<b>Power source:</b>	5 V DC	5 V DC
<b>Power consumption:</b>	40 mA (max.)	35 mA
<b>RF output:</b>	30-39CH selectable	0CH/1CH selectable
<b>Dimensions: (W x D x H)</b>	75 x 30.4 x 51 mm	75 x 34.5 x 51 mm
<b>Weight:</b>	200 g	150 g

## VL-7 Battery Video Light System:

<b>Central light intensity:</b>	Video light can be attached to the main body via the accessory shoe, and can be turned on or off during recording or record pause mode.
<b>Illumination angle:</b>	Approx. 120 cd
<b>Central luminosity:</b>	Approx. 30°
<b>Colour temperature:</b>	Approx. 15 lux (3 m)
<b>Power consumption:</b>	Approx. 3200K
<b>Required bulb:</b>	6 W (6 V)
<b>Bulb life:</b>	Canon Halogen Bulb MHL-5.7V 6 W
<b>Operating temperature range:</b>	Approx. 50 hours
<b>Power supply:</b>	0°C—40°C
<b>Illumination time:</b>	Battery pack mounted on the main body
<b>Dimensions: (W x D x H)</b>	Approx. 15 min. (with BP-E77K in continuous use)
<b>Weight:</b>	40 x 43 x 56 mm 35 g

\* Canon recommends metal particle tape.

Weight and dimensions are approximate. Errors and omissions excepted.  
Subject to change without notice.

# MEMO

A series of horizontal dotted lines for writing, starting below the 'MEMO' header and extending to the bottom of the page.

# Canon

**CANON INC.** 7-1, Nishi-Shinjuku 2-Chome, Shinjuku-Ku, Tokyo 163-07, Japan  
Mailing address: P.O. Box 5050, Dai-ichi Seimei Building, Tokyo 163, Japan

**Canon Europe N.V.**

P.O. Box 2262, 1180 EG Amstelveen, The Netherlands

**Canon UK Ltd.**

Units 4, 5 & 6, Brent Trading Centre, North Circular Road, London NW10 0JF, United Kingdom

**Canon Australia Pty. Ltd.**

1 Thomas Holt Drive, North Ryde, N.S.W. 2113, Australia

**Canon New Zealand Ltd.**

Fred Thomas Drive, Takapuna, P.O. Box 33-336, Auckland, New Zealand

**Canon Singapore Pte. Ltd.**

# 13-01/15, Pidemco Centre, Singapore 0105

**Canon Hongkong Trading Co., Ltd.**

10/F Mirror Tower, 61 Mody Road, Tsimshatsui East, Kowloon, Hong Kong

**Canon Latin America, Inc.**

DEPTO DE VENTAS Apartado 7022, Panamá 5, República de Panamá

CENTRO DE SERVICIO Y REPARACION Apartado 2019, Zona Libre de Colón, República de Panamá

