

**Canon**  
advanced simplicity™

**35mm SLR Camera  
EOS 3000N**

**The great value EOS  
that's the perfect introduction  
to photography.**



## When you're moving up...

When you're moving up in the world and want to capture those all-important moments, you need a stylish camera that offers simplicity of operation as well as the high-tech functions that guarantee perfect results with every shot.



Canon has developed the EOS 3000N as the perfect camera for the first-time SLR user, with stunning gunmetal-silver finish good looks, that also provides the serious amateur with cutting-edge photographic performance and access to the complete range of EOS interchangeable lenses.

The camera can be operated entirely on automatic, with point-and-shoot ease, or you can take control and add your own creativity to the shot. If you leave things up to the camera, the EOS 3000N has photographic expertise built in with a range of settings that still let you take exactly the shot you want: close-up, portrait, landscape or even more adventurous action or beautiful nightshots – at a split-second's notice.

All this thanks to the easy-to-operate Command Dial and the super-clear LCD panel which give you the full camera status at a glance.

# aim higher

Then, there are advanced features to give you that unique “professional” edge. The 3-point autofocus allows you to focus on off-centre subjects; auto exposure bracketing virtually assures you'll hit the optimum exposure even under the most challenging lighting conditions; and multiple-exposure function allows you to be creative and take a double exposure or up to nine exposures – on a single frame!

So aim higher with the new Canon EOS 3000N. It feels good, it looks good and it shoots even better!

## FEATURES

### 3-Point Autofocus for sharp, clear photos

With Canon's unique wide-area 3-point autofocus system, as long as your subject is within one of the three focusing points: centre, left or right, it will remain sharp, even if it is off centre or a moving target.

### User-selectable autofocus points for added creativity

The EOS 3000N lets you select from three AF points – left, centre or right, giving you the freedom to compose your shot while retaining the advantages of Canon's advanced autofocus technology.



Wide-Area 3-Point Autofocus System



Three AF Points: Left, Centre or Right



# with EOS 3

## 10 AUTO EXPOSURE MODES

### Full Program (P)

You concentrate on your shot. The camera selects both shutter speed and aperture automatically.

### Shutter Priority (Tv)

You select the shutter speed for creative action shots. The camera sets the aperture to match lighting conditions.

### Aperture Priority (Av)

You select an aperture setting to control the depth of field. The camera sets the shutter speed.

### Automatic Depth of Field (A-Dep)

This mode determines the nearest and farthest subject points then sets an aperture to keep everything in your selected area in focus.

### Full Manual Control too!

Lets you take full control and imprint your creativity on your shots.

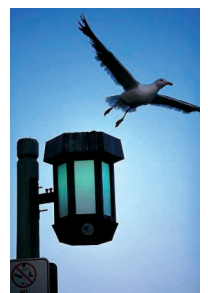

Full Program: Camera selects both shutter speed and aperture

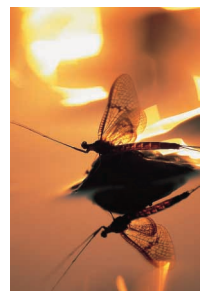

Manual: You take full control

### Green Zone / Full Auto

Green means go! Full Auto means just point and shoot – ideal for family snaps.

### Portrait

In Portrait mode, the camera renders the background in soft focus so your subject will stand out beautifully.

### Landscape

Landscape mode selects a small aperture perfect for capturing panoramic holiday vistas.

### Macro

Provides optimum settings for dramatic close-ups of flowers, jewellery etc.

### Sports

The faster shutter speeds, tracking focus and continuous exposures of Sports mode let you capture the action.

### New Night Shot Mode

Balances flash exposure with the glow of background lighting for breathtaking results.



Green Zone/Full Auto: Point and Shoot



Macro: Settings for Dramatic Close-Ups



Night Shot Mode

# 0 0 0 N

## WHY CHANGE LENSES?

The EOS 3000N can use the entire range of over 50 EF interchangeable lenses shared by all Canon EOS cameras, up to our top professional models.

The extensive range of Canon EF Lenses can add another dimension to your photography. Sample the technology of a USM lens – the ultrasonic motor providing fast and whisper quiet focusing ensures that you don't have to sacrifice anything for that shot. Versatility is further afforded by Canon's unique Image Stabilizer (IS) lenses. When it's impossible to use a tripod, only a Canon IS lens will compensate for natural camera shake and unfailingly delivers sharp results.



aim higher...

# EOS 3000N

- 10 auto exposure modes plus full manual control
- 3-point auto-focus with user-selectable focusing points
- auto exposure bracketing
- multiple exposure
- advanced E-TTL flash hotshoe
- choose from over 50 Canon EF interchangeable lenses



# EOS 3000N Specifications



**AF Focusing Point:** (1+1). Focusing Point Selection: Automatic Selection, Manual Selection. AF Mode, One-shot AF, AI Focus AF. Working Range (EV at ISO 100): 2 – 18. LED/Beeper: Yes / Yes. User-Selectable Focusing Points: Yes, 3 points.

**Built-in AF-assist light** Type: Lamp. Effective Range at Center/Sides (m): 4 / 2.5. Wide-Angle Coverage (mm): 35. AF-Assist ON Switch: Nil.

**Viewfinder** Coverage (%): 90 x 90. Magnification (50mm lens at infinity): 0.70. Eye Relief (mm): 18.5. Pentaprism: Roof prism mirror. Built-in-Dioptic Correction: Nil. Display: Digital Readout Metered Manual.

**Metering** Evaluative Metering Zones: 6. Linked Focusing Points: Yes. Spot Metering: Nil. Partial Metering: Yes. Centerweighted Averaging Metering: Yes. Metering Range (EV at normal temperature): 2 – 20.

**Exposure Control** P, Tv, Av, M: Yes. Depth-of-field AE: Yes (A-DEP). Full Auto: Yes. Night-Shot Mode: Yes. Programmed Image Control Modes (Qty): Yes (5). AE Lock: Yes. Autoflash Metering System: E-TTL, A-TTL, TTL. Exposure Compensation: Yes. Auto Exposure Bracketing: Yes. Multiple Exposures (max. Setting): Yes (9). ISO Range (Increments): Automatic 25 – 5000 (1/3). Manual 6 – 6400 (1/3). Auto Exposure Bracketing (Increments): 0 to ± 2 (1/2).

**Shutter** Shutter Speed Range (Increments): 1/2000 – 30, B (1/2). X-sync (sec.): 1/90 sec, or slower.

**Film Transport (24 – ex.)** Fully Automatic: Yes. Silent Operation: Yes. Film Advance Modes: Single Frame Advance, Continuous Film Advance. Film Advance Speed (fps): 1. Prewind Speed (sec.): 9 sec. (prewind). No. of Rolls (AE 100% / FA 50%): 85/35.

**Built-in Flash** Pop-up / Retraction: Manual. ON/OFF Switch: Nil (by manual, pull up). Focal Length Coverage (mm): 28. Guide No. (ISO 100 in m): 12. Red-eye Reduction ON/OFF: Yes. Automatic Firing in Backlight / Low-light: Yes (with flash popped up). Slow Sync Speed: Yes. Flash Exposure Compensation: Nil. Flash Metering Zones (Qty): Yes (3). Recycling Time (sec.): 2.

**External LCD Panel / Main Camera Control** LCD/Electronic dials.

**Remote Control Terminal** Yes.

**External Power Source Compatibility** Yes.

**Power source** CR123A x 2.

**Dimensions (W x H x D mm)** 145 x 92 x 64.7.

**Weight (date model excluding batteries)** 365g.

All data are based on Canon's Standard Test Method. Subject to change without notice

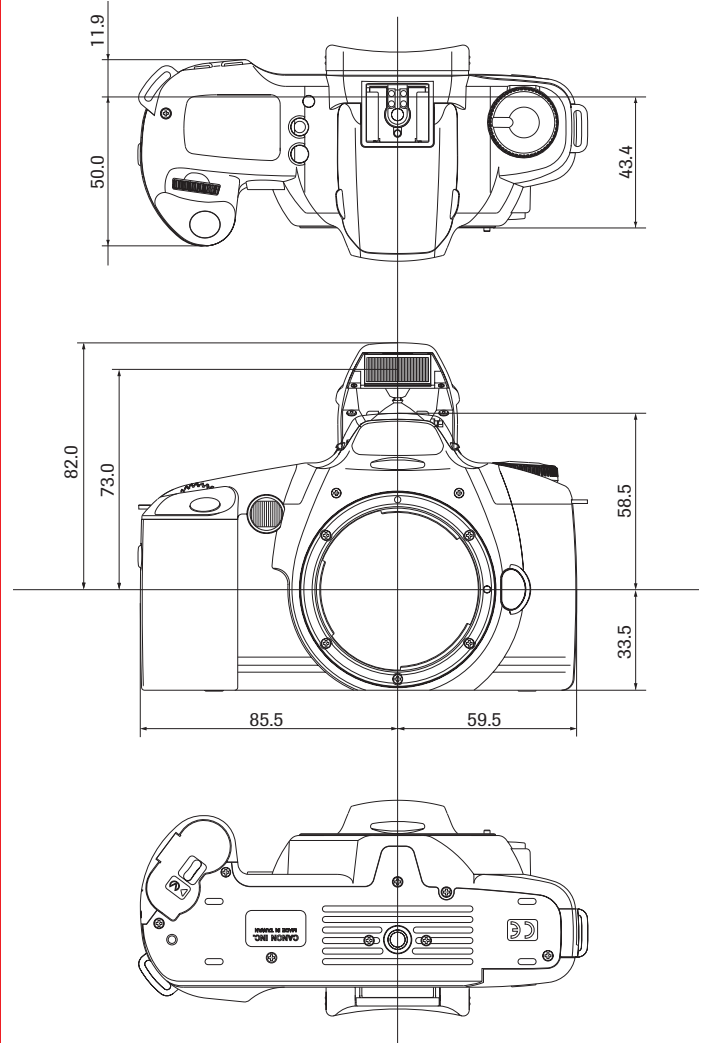

EOS 3000N date model also available



**Canon Australia Pty. Ltd.**  
ABN 66 005 002 951

1 Thomas Holt Drive,  
North Ryde, NSW 2113, Australia  
Freecall: 1800 021 167  
Facsimile No: + 61 2 9888 3650

**Canon New Zealand Limited**  
Akoranga Business Park,  
Akoranga Drive, Northcote, Auckland, New Zealand  
Telephone No: 0800 222 666  
Facsimile No: + 64 9 489 0380

[www.canon.com.au](http://www.canon.com.au)  
[www.canon.com.au/digitalimage](http://www.canon.com.au/digitalimage)  
[www.canon.co.nz](http://www.canon.co.nz)