

# PowerShot S230 DIGITAL IXUS V<sup>3</sup>

Digital Camera

English Edition



© CANON INC. All Right Reserved

**1** GENERAL  
DESCRIPTION OF  
PRODUCT

**2** TECHNICAL  
DESCRIPTION

**3** REPAIR  
INSTRUCTION

**4** PARTS CATALOG

**5** DIAGRAMS

**6** APPENDIX



## SAFETY PRECAUTIONS

The following precautions should be observed when servicing.

1. Since many parts in the unit have special safety-related characteristics, always use genuine CANON replacement parts. Especially critical parts in the power circuit block should not be replaced with other makes. Critical parts are marked with  $\triangle$  in the schematic diagrams.
2. When servicing, observe the original lead dress. If a short circuit is found, replace all parts which have been overheated or damaged by the short circuit.
3. After servicing, see to it that all the protective devices such as insulation barriers, insulation papers shields are properly installed.
4. After servicing, make the following leakage current checks to prevent the customer from being exposed to shock hazards.

### 4-1 Leakage Current Cold Check

- 1) Unplug the AC cord and connect a jumper between the two prongs on the plug.
- 2) Measure the resistance value, with an ohmmeter, between the jumpered AC plug and each exposed metallic cabinet part on the equipment such as screwheads, connectors, control shafts, etc. When the exposed metallic part has a return path to the chassis, the reading should be between  $1M\Omega$  and  $5.2M\Omega$ . When the exposed metal does not have a return path to the chassis, the reading must be  $\infty$ .

### 4-2 Leakage Current Hot Check

- 1) Plug the AC cord directly into the AC outlet. Do not use an isolation transformer for this check.
- 2) Connect a  $1.5K\Omega$  10 watt resistor, paralleled by  $0.15\mu F$  capacitor, between each exposed metallic parts on the unit and a good earth ground such as a water pipe, as shown in the figure below.
- 3) Use an AC voltmeter, with  $1000\Omega/\text{volt}$  or more sensitivity, to measure the potential across the resistor.
- 4) Check all exposed metallic parts of the cover (Cable connection, Handle bracket, metallic cabinet. Screwheads, Metallic overlays, etc), and measure the voltage at each point.
- 5) Reverse the AC plug in the AC outlet and repeat each of the above measurements.
- 6) The potential at any point should not exceed 0.75V RMS.

A leakage current tester (FLUKE MODEL : 8000A equivalent) may be used to make the hot checks.

Leakage current must not exceed 0.5 milliamp.

In case a measurement is outside of the limits specified, there is a possibility of a shock hazard, and corrective action must be taken before returning the instrument to the customer.

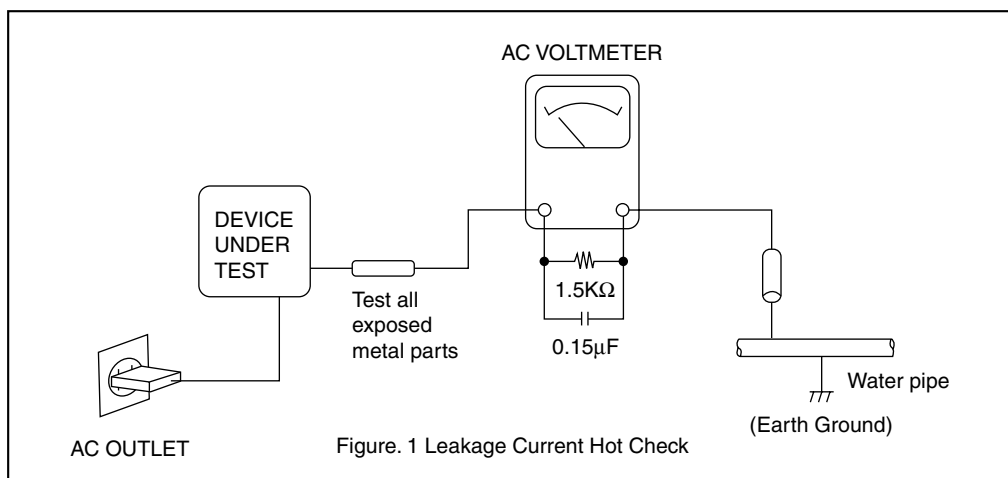

## **Application**

This manual has been issued by Canon Inc. for qualified persons to learn technical theory, and repair of the products.

## **Corrections**

This manual could include typographical errors or technical inaccuracies due to improvements or changes in the products. When changes occur in applicable products or in the content of this manual, Canon will release service manual report as the need arises. In the event of major changes in the contents of this manual over a long or short period, Canon may issue new editions of this manual.

The following paragraph does not apply to any countries where such provisions are inconsistent with local law.

## **Trademarks**

The product names and company names described in this manual are the registered trademarks of the individual companies.

## **Copyright**

This manual is copyrighted with all rights reserved. Under the copyright laws, this manual may not be copied, reproduced, published (including on the World Wide Web) or translated into another language, in whole or in part, without the written consent of Canon Inc..

Copyright © 2002 by Canon Inc.  
CANON INC.  
Digital Imaging Products Service Dept.  
30-2, Shimomaruko 3-Chome, Ohta-ku,  
Tokyo 146-8501, Japan

# CHAPTER 1. GENERAL DESCRIPTION OF PRODUCT

## CONTENTS

1	Development Background	
1-1	Development Objectives -----	1-1
1-2	Product Concept -----	1-1
1-3	Design Concepts -----	1-4
1-4	Spec. comparison between IXY DIGITAL 320 and 200a -----	1-5
2	Features	
2-1	High Grade Design / Ultra Compact -----	1-6
2-2	Full Features / Operation Ease -----	1-7
2-3	High Image Quality -----	1-10
2-4	System Accessory / Application Softwares -----	1-11
3	Exterior	
3-1	Exterior Photos -----	1-16
3-2	6-dimensional diagram -----	1-17
3-3	Nomenclature -----	1-18
3-4	UI Information -----	1-19
4	Specifications	
4-1	Camera Specifications -----	1-21
4-2	System Requirements -----	1-32
5	System	
5-1	Accessories Compatibility -----	1-33
5-2	System diagram -----	1-35
6	Additional	
6-1	iSAP (Intelligent Scene Andlysis based on photographic Space) Technology -----	1-36

*\*The "IXY DIGITAL 320" Product designation used in this document refers to the IXY DIGITAL 320,  
The DIGITAL IXUS v<sup>3</sup> and PowerShot S230 DIGITAL ELPH designations are used in various marketing areas.*



# 1 Development Background

## 1-1 Development Objectives

The original IXY DIGITAL first put on sale in May 2000 has evolved through the IXY DIGITAL 200, released in 2001, leading up to the present IXY DIGITAL 200a in 2002. Nevertheless, in the last year, our competitors have been releasing cameras with similar (flat-front, compact, high-grade) concepts to the IXY DIGITAL series, and 3-megapixel CCD models have also been appearing.

While the IXY DIGITAL series has been maintaining its popularity since it went on sale by incorporating consistently superior “picture quality”, “functions” and “operability” to that of competitive models through model changes, fans of the IXY have been clamoring for 3-megapixel CCD capability.

With this background in mind, the IXY DIGITAL 320, equipped with a 3-megapixel CCD and the newly developed digital imaging processor “DIGIC (Digital Imaging Processor)”, will be added to the series. By also further enhancing the movie features, we have produced a camera that will maintain our advantage over rival models.

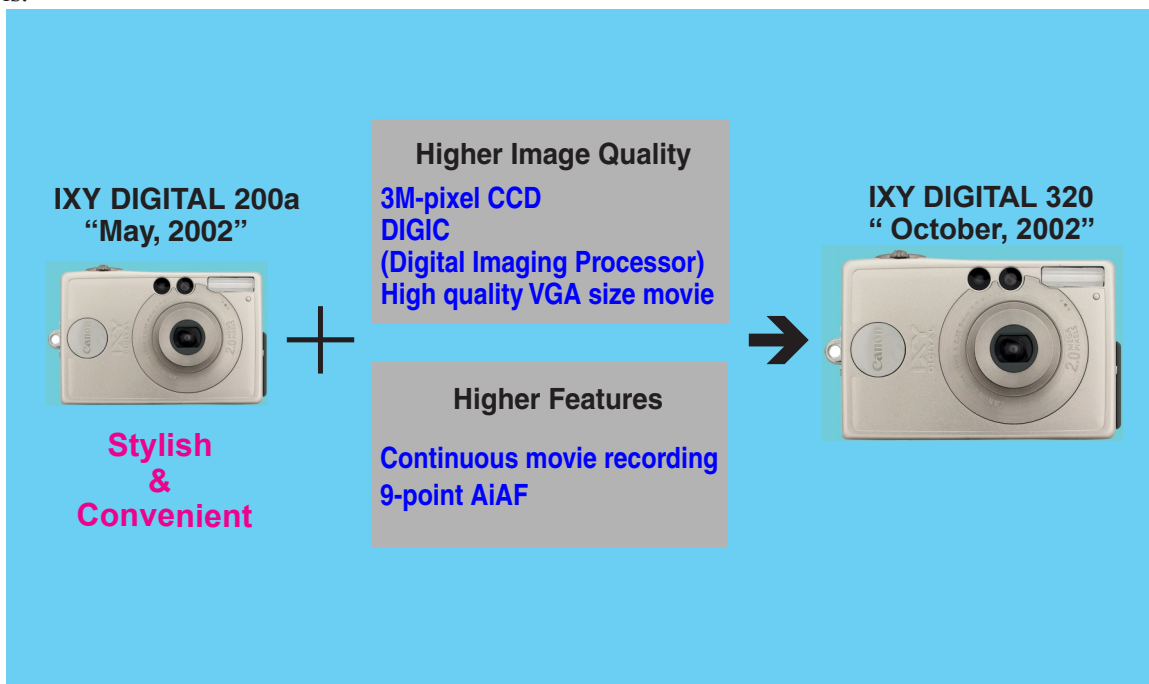

## 1-2 Product Concepts

The IXY DIGITAL 320 will have the same basic exterior appearance as the IXY DIGITAL 200a, with its highly perfected finish; however, to differentiate it from the IXY DIGITAL 200a, the processing of external parts and materials has been revised in order to generate more appeal for its higher picture quality as a result of the 3-megapixel CCD and its improved movie functions.

Furthermore, “Direct Print” support, a basic concept of Canon’s digital cameras, provides an environment in which high-picture-quality prints can be obtained easily by combining the camera with a CP-100/10 card photo printer or an Exif 2.2 compatible Bubble Jet printer (BJ 895PD/BJ 535PD).

## High grade design / Ultra compact

- U - Thin stylish design for enhanced high-grade character
  - Low-temperature, polysilicon 1.5-inch LCD monitor with power-saving design
  - Small, high-efficiency light guide flash enhances reliability
  - CSP-IC on both side of the board allows higher density mounting

## Full Features / Operation Ease

- N - Selectable nine-points AiAF and single-point AF (range frame can be set arbitrarily)
- N - Settable display times for rec review (Off, 2 to 10 seconds)
- N - Continuous movie recording and replay with audio with long filming times (VGA : 30 sec. /QVGA : 3 minutes / QQVGA : 3 minutes)
- N - Unwanted scenes can be deleted in movie playback mode
- N - New fast image storage CF card (256 MB)
- N - Driver-less computer connections with Picture Transfer Protocol (PTP) support
- U - Digital zoom function with continuously changing angle of view (Approx. 6.4x when used in combination with an optical zoom)
- U - Total of 12 image quality modes (4 recording pixels x 3 compression ratio)
- U - Direct Print function with cropping capability for dedicated printers (card photo printers CP-100/10) and Bubble Jet printers (BJ 895PD/535PD/F890PD)
  - Photo effect modes (Vivid color, Neutral color, Low sharpening, Sepia and Black & White) are provided
  - Real-image optical zoom viewfinder
  - Two types of metering function that are spot metering and evaluative metering
  - AF, AE and FE lock feature enabling focus and exposure lock when taking photos
  - On/Off selection of AF-assist Beam available
  - Fifteen-second long exposure added to 1 to 1/1500-second shutter speeds
  - Continuous shooting (approx. 2 images/sec. when LCD monitor is off)
  - Stress free operation owing to DIGIC (Digital Imaging Processor) and large capacity buffer memory
  - SI (Super Intelligent) sensor automatically detects vertical or horizontal photography
  - Convenient operation using cross-configured buttons
  - Built-in flash with five flashing modes
  - Built-in flash range of 3.0 m (wide-angle end) and slow-sync speed mode is provided
  - Self-Timer function (selectable of 2 or 10 seconds)
  - Histogram displays during rec review function and playback
  - Reset of all settings by one-touch operation
  - Mode switch to select still photography, movie photography or playback
  - High-speed image feed on playback
  - Magnified playback for convenient image confirmation (from approx. 2x to 10x zoom)
  - Supports DPOF slideshows and image transfers



- Selectable video output format (NTSC/PAL)
- High-speed image transfer on USB Interface
- International supporting twelve languages

## High Image Quality

- N - 1/2.7-type approx. 3.2M camera effective pixels CCD (3.3M-pixels in total)
- N - High definition and fast processing with the newly developed DIGIC (Digital Imaging Processor)
- N - VGA size movie achieves higher image quality
  - Fine color reproduction owing to primary color filters
  - High-resolution retractable 2x zoom lens
  - New image capturing optics brings out high resolution
  - Noise reduction feature for high S/N
  - Built-in SI Sensor enhances precision of AE, AF and AWB
  - Wide range of ISO-equivalent speed settings (Auto/ISO 50/100/200/400 equivalent)
  - High-precision white balance (Auto + Five preset positions + Custom)
  - Totally round aperture for better background blur
  - Applying to Exif 2.2

## System accessories / Application software

- Waterproof case good to 30 m (100 ft) underwater (Equipped with flash diffusion plate)
- Compact Li-ion battery with high energy capacity (Nominal capacity : 840 mAH)
- Compact car battery charger for Li-ion battery
- Compact power adapter also compatible with the PS A-series
- Full featured application software
- N - ZoomBrowser EX 4.0 (Win) made more ergonomic
  - (ImageBrowser 2.7 (for Mac) is as in the past)
  - Photorecord 1.6 (Win) for easy layout and printing of many pictures
  - PhotoStitch 3.1 for creating panoramic pictures with precision
  - RemoteCapture 2.6 for remote picture-taking through a PC (permits display of the Finder screen on the PC)
- N - New File Viewer Utility 1.0 application for developing RAW images
  - TWAIN Driver 5.0 / WIA Driver 5.0 (Win)
  - USB Mounter 1.8 (Macintosh) that allows the system to handle the camera as a card reader
  - Printer Driver CP-100/CP-10 2.1 for prints from a pictures in PC
  - Adobe Acrobat Reader 4.0 for Printer driver's manual
  - Proven third-party software
    - ArcSoft PhotoImpression 4.0 (Win) / 4.0 (Mac ) (processing/editing for still images)
    - ArcSoft VideoImpression 1.7 (Win) / 1.6 (Mac) (processing/editing for movies)

### 1–3 Design Concepts

The IXY DIGITAL 320 strives for an evolution befitting a premium three-megapixel camera while continuing the precedent set by the basic external appearance of the IXY DIGITAL 200a.

This model uses a different type of processing for external parts and materials in order to create more appeal for the high picture quality sensor and lens, achieving a refined texture with more character that instills a sense of satisfaction through the pleasure of possessing a tool.

- Silky hairline finishing given to the circle section

On our previous models, hairline processing was applied after blast processing of stainless materials to create a circle motif on the body around the lens. However, for the IXY DIGITAL 320, the base stainless materials have been replaced with a highly luminous type and the area around the lens is masked when blast processing is applied. Following this, through hairline processing, a more subtle and higher quality hairline finishing than previous models is achieved.

As a synergetic effect of preserving the luminance of the recessed megapixel and lens inscriptions in the circle area, we have been able to make the letters stand out in bold relief.

- Use of a light gold emblem and revamped finishing of metal-plated parts

The three metallic parts on previous models — the zoom lever, strap clip and Canon emblem — expressed a sense of class with a trivalent chrome plating with a black shine.

On the IXY DIGITAL 320, however, nickel-velour (satin finishing) plating with a bright impression is employed for the zoom lever and strap clip parts, while the emblem section has been plated with a light gold giving off a golden glimmer. Combining these elements convey an image of refined character like a personal accessory rather than just the sensation of a camera.



## 1-4 Spec. Comparison between IXY Digital 320 and IXY Digital 200a

		IXY DIGITAL 320	IXY DIGITAL 200a
Image sensor (CCD)		Camera effective pixels : Approx. 3.2 M 1/2.7 inch size (Total pixels: Approx. 3.3 M)	Camera effective pixels : Approx. 2 M 1/2.7 inch size (Total pixels: Approx. 2.1 M)
Color filter		Primary color filter (Beyer)	←
Lens (35mm film equivalent)		35-70 mm, F2.8-4.0	←
Optical zoom		2x	←
Digital zoom		Approx. 3.2x	2.5x
Shooting distance (from tip of the lensbarrel)	Normal	47cm - infinity	57cm - infinity
	Macro	10 - 47cm(W), 27 - 47cm(T)	10 - 57cm(W), 27 - 57cm(T)
Optical viewfinder		Real-image optical zoom view finder	←
LCD monitor		1.5 inch low -temperature polycrystalline silicon TFT color LCD	←
Autofocus		9 points (AiAF) / 1 point (Center) (AF lock is available)	3 points (AiAF) / 1 point (Center) (AF lock is available)
Metering modes		Evaluation (AF point-linked) / Spot	←
Exposure control system		Program AE	←
Exposure compensation		+/- 2 stops in 1/3-stop increments	←
Sensitivity (ISO film speed)		Auto / ISO 50/100/200/400 equivalent	←
White balance		Auto + Pre-set (5 positions) + Manual	←
Shutter type		Mechanical shutter + electronic shutter	←
Shutter speed		15 - 1/1500 sec.	←
Flash range		47 cm - 3.0 m (W), 47 cm - 2.0 m (T)	57 cm - 3.0 m (W), 57 cm - 2.0 m (T)
Shooting specifications		Auto/ Manual/ Stitch assist/ Movie	←
Continuous shooting		Approx. 2.0 images/sec (L/F, LCD Monitor OFF)	Approx. 2.5 images/sec (L/F, LCD Monitor OFF)
Recording media		CompactFlash card (Type I)	←
File format	Still	Design rule for Camera File system, DPOF(Ver 1.1) compliant	←
	Movie	AVI	←
Recording format	Still	JPEG (Exif 2.2 compliant) / RAW	←
	Movie	Image: Motion JPEG Audio:WAVE(Monaural)	←
Recording pixels	Still	(L) 2048×1536, (M1) 1600×1200 (M2) 1024×768, (S) 640×480	(L) 1600×1200 (M) 1024×768, (S) 640×480
	Movie	(VGA) 640×480 Approx. 30 sec. at 15 fps (QVGA) 320×240 Approx. 3 min. at 15 fps (QQVGA) 160×120 Approx. 3 min. at 15 fps	(VGA) 640×480 Approx. 4 sec. at 20 fps (QVGA) 320×240 Approx. 10 sec. at 20 fps (QQVGA) 160×120 Approx. 30 sec at 20 fps
JPEG compression mode		(SF/F/N) x (L/M1/M2/S) (12 pattern)	(SF/F/N) x (L/M/S) (9 pattern)
Play mode		Single / Index (9 thumbnail images) / Slide show / Movie / Magnification (2-10x)	←
Direct print		O	←
Interface		USB, Audio / Video output	←
Power supply	Source	Rechargeable Lithium battery (NB-1LH) / Compact Power Adapter (CA-PS500) + DC coupler (DR-500) / Car Battery Adapter (Optional Car Battery Cable CBC-NB1 is recommended)	←
	Performance	Shooting capacity: Approx. 170 images (LCD monitor ON) Approx. 420 images (LCD monitor OFF) Playback time: Approx. 130 min.	Shooting capacity: Approx. 150 images (LCD monitor ON) Approx. 420 images (LCD monitor OFF) Playback time: Approx. 100 min.
Dimensions (W x H x D)		87.0 x 57.0 x 26.7 mm	←
Weight (excluding batteries and CF card)		Approx. 180 g	←

## **2 Features**

### **2-1 High Grade Design / Ultra Compact**

#### **- Thin stylish design for enhanced high-grade character**

The IXY DIGITAL 320 strives for an evolution befitting a premium three-megapixel camera while continuing the precedent set by the basic external appearance of the IXY DIGITAL 200a.

This model uses a different type of processing for external parts and materials in order to create more appeal for the high quality picture sensor and lens, achieving a refined texture with more elegant character that instills a sense of satisfaction through the pleasure of possessing a tool.

(See Design Concepts on page 5)

## 2-2 Full Features / Operation Ease

### - Selectable 9-point AiAF and single-point AF (range frame can be set arbitrarily)

The AiAF range frame for the IXY DIGITAL 320 has been increased from the previous 3 points (IXY DIGITAL 200a) to 9 points. As a result, framing unconstrained by the position of the subject is possible. *With multiple focus points, the respective range frames for the focus points are displayed in green (when there are two or more focus points, the range frames for all focus points are shown).*

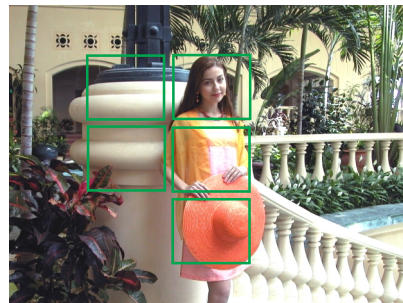

Photo 2-1 9-point AiAF

IXY DIGITAL 320 also employs standard AF system that use AF frame with a single center point, so that user can choose the convenient method depending on photographic conditions.

### - Settable display times for rec review (2 to 10 seconds)

The Ixy digital 320 is specified so that the image-display time\* in rec review (confirmation of recorded image) can be set between two and 10 seconds in 1 second intervals. In this way, users can select a duration to suit their applications.

\* "Off" can also be set

### - Continuous movie recording and playback with audio with long filming times (3 minutes) (selectable from QVGA and QQVGA)

The Ixy digital 320 can record moving images at 15 frames per second along with audio in 2 formats, QVGA (320 by 240 pixels) and QQVGA (160 x 120 pixels). Because a method is employed that consecutively writes images that are temporary stored in the buffer to the CF card while recording, long continuous filming times are also achieved.

In practice, if the write speed of the CF card is slower\*<sup>1</sup> than the speed to write an image to the buffer, the recording will stop when the buffer capacity is reached. Taking this circumstance into account, the specification limits the maximum recording time in both QVGA and QQVGA formats to three minutes. Even after three minutes of elapsed filming, the G3 allows the next recording to be resumed in less time than previous models.

During filming, the values for the focus, exposure, white balance and zoom position determined at the beginning are used continuously to the end of the recording. The storage time is also displayed on the LCD monitor during filming.

The file is saved in AVI format, while the image is saved as Motion JPEG data and the audio data in WAVE format (mono).

\*<sup>1</sup> The write speed varies depending on the brand and capacity of the CF card.

\*<sup>2</sup> If the free space on the CF card is less than the size of the recording, recording will stop just prior to the CF card reaching full capacity.

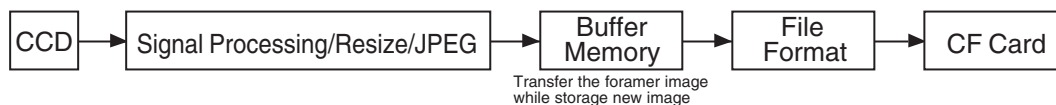

Figure 2-1 Conceptual diagram of continuous moving image recording

**- Unwanted scenes can be deleted in movie playback mode**

The Ixy digital 320 allows unwanted sections to be deleted in the movie playback mode. However, the sections that can be deleted are either from the start of the recording to an arbitrary point or from an arbitrary point to the end of the recording.

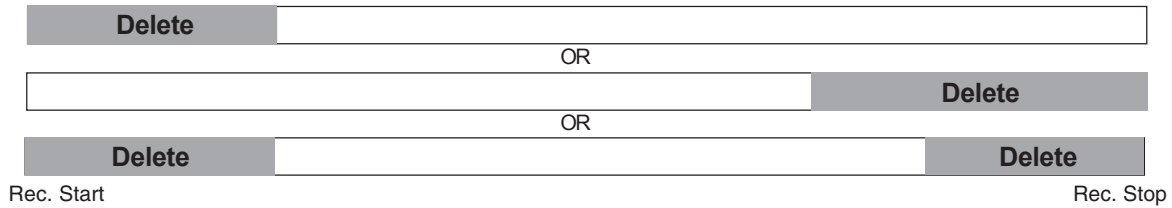

Figure 2-2 Conceptual diagram of movie editing

**- New fast image storage CF card (256 MB)**

A new high-capacity FC-256MH CF card with reduced write times has been configured to handle long continuous storage\* of moving images. The capacity of the card is 256 MB.

*\* Not available in USA market*

**- Driver-less computer connections with Picture Transfer Protocol (PTP) support**

Because the Ixy digital 320 supports PTP, a standard protocol, driver-less image communications with computers is possible when combined with recent operating systems (Windows XP or Mac OS X (version 10.1)). Specifically, selecting PTP from the “communications setting” on the camera menu, the following functions can be controlled from the computer by simply connecting the camera.

- View images in the camera
- Transfer images in the camera to the computer
- Delete images in the camera from the computer

**- Digital zoom continuously changes the field of view (approx. 3.2x ; approx. 6.4x magnification when combined with optical zoom)**

The digital zoom magnification of IXY DIGITAL 320 enlarges from 2.5x that is employed on the prior IXY series to approx. 3.2x owing to employment of 3M-pixel CCD. It can adjust the field of view by up to a maximum of 6.4x (35 mm film equivalent:35 to 224 mm) by combining a 3.2x digital zoom magnification with the optical 2x zoom lens.

Furthermore, several dozen image input positions are calibrated for the monitor display to ensure a smooth digital zoom of the image on the monitor display. The actual zoom position can be stopped in six positions including both end positions in consideration of practicability.

Due to fast signal processing, the optical zoom and digital zoom are driven at nearly the same speed so that no peculiarity is sensed in operation (during switchover).

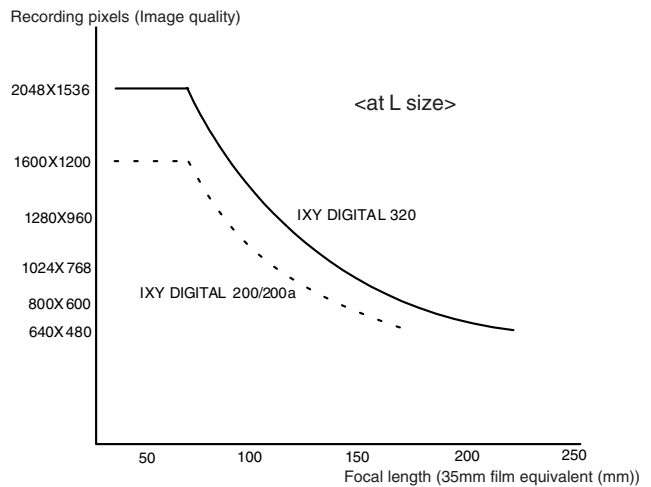

Figure 2-3 Digital zoom (Image quality)

**- Total of 12 image quality modes**

Since the number of CCD pixels has been increased to approx. 3.0 million camera effective pixels with the IXY DIGITAL 320, there are now 4 possible settings for the number of recording pixels: Large, Medium 1, Medium 2, and Small.

	Recording Pixels
Large	2,048×1,536
Medium 1	1,600×1,200
Medium 2	1,024×768
Small	640×480

Table 2-1 Recording pixels

Since there are also 3 compression rates (Superfine, Fine and Normal), a total of 12 different combinations can be selected.

**- Direct Print function with cropping capability for dedicated printers (card photo printers CP-100/10) and Bubble Jet printers (BJ 895PD/535PD/F890PD)**

The Direct Print function has been added to the IXY DIGITAL 320 so that high-picture-quality prints can be made easily by merely connecting the camera with the supplied cable to a Canon card photo printer (CP-10/100) or a Bubble Jet printer (BJ F895PD/BJ F535PD/BJ F890PD). High-quality prints can be readily attained with the BJ 895PD and BJ 535PD in particular since they support Exif 2.2.

Furthermore, the IXY DIGITAL 320 adds a “cropping” capability not found on the IXY DIGITAL 200a, which allows the user to expand and print an area of the image. After selecting the cropping mode, the section denoted by the frame superimposed over the image displayed on the LCD monitor can be printed. The size of the frame can be adjusted in either 8 steps (when placed horizontally) or 5 steps (when placed vertically) with the zoom lever and the position can be moved with the cross-configured buttons.

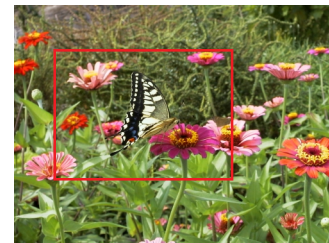

Photo 2-2 Cropping window

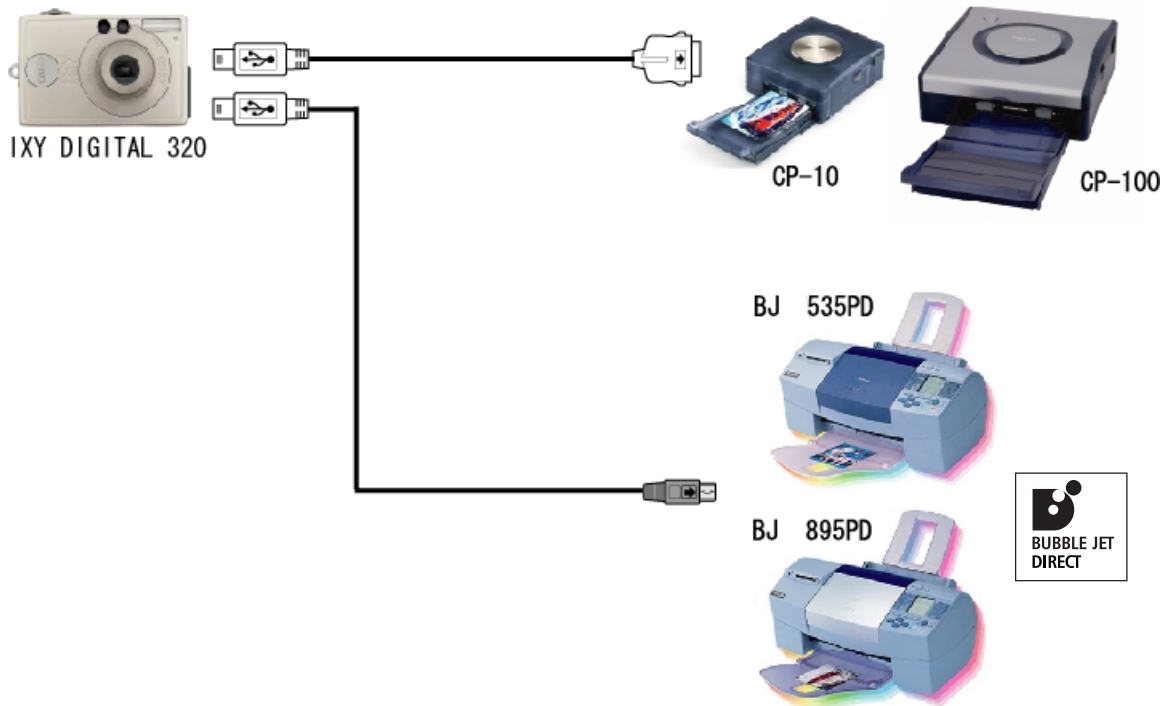

Figure 2-4 Direct print

## 2-3 High Image Quality

### - 1/2.7-inch CCD with approximately 3.2 million camera effective pixels (total of about 3.3 million pixels)

The IXY DIGITAL 320 is equipped with a newly developed 1/2.7-inch 3.3 million pixel CCD (about 3.2 million camera effective pixels). The pixel pitch of this CCD is 2.575mm by 2.575mm, achieving a huge 39 percent size reduction in the area ratio of the chip when compared to conventional 1/1.8-inch three-megapixel-class CCDs (found on the PowerShot G1/S30). Because of this, it is possible to appropriate the optical system and body of the previous IXY DIGITAL 200a, resulting in an ultra-compact three-megapixel-class digital camera.

### - High definition and fast processing with the newly developed “DIGIC (Digital Imaging Processor)”

The IXY DIGITAL 320 comes equipped with the “DIGIC (Digital Imaging Processor)”, a newly developed image processor. DIGIC (Digital Imaging Processor) achieves enhanced high picture quality by improving signal processing algorithms as the successor of prior processor.

The following\* are the main advances of the DIGIC (Digital Imaging Processor).

- Improved picture quality
- Improved AF accuracy
- Improved processing speed

*\* The DIGIC (Digital Imaging Processor) features many improvements, but the three points above are the principle contributions to the Ixy digital 320.*

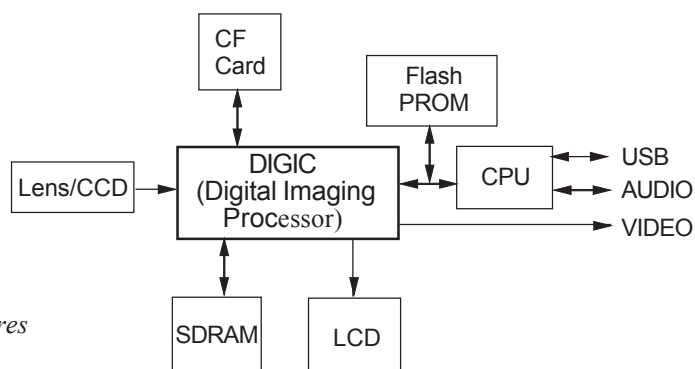

Figure 2–5 Block diagram

### - VGA-size movies that achieve higher picture quality

The new 3-megapixel CCD of the IXY DIGITAL 320 can read 1 line of every 3 lines in the lengthwise direction due to a change in the electrode structure (charge reading method). Because of this innovation, a moving image with 524 lines per frame can be created resulting in a huge step forward in quality in comparison to VGA-size movies of previous models (pixel interpolation\* types).

However, with the increase in the number of CCD pixels, the frame rate is reduced to 15 frames per second from the IXY DIGITAL 200a’s 20 frames per second.



## 2-4 System Accessories/ Application Softwares

### - Full featured application software

Figure 2-6 illustrates the general organization of the application software bundled with the IXY DIGITAL 320. Tables 2-2 and 2-3 list the content of each CD-ROM disk.

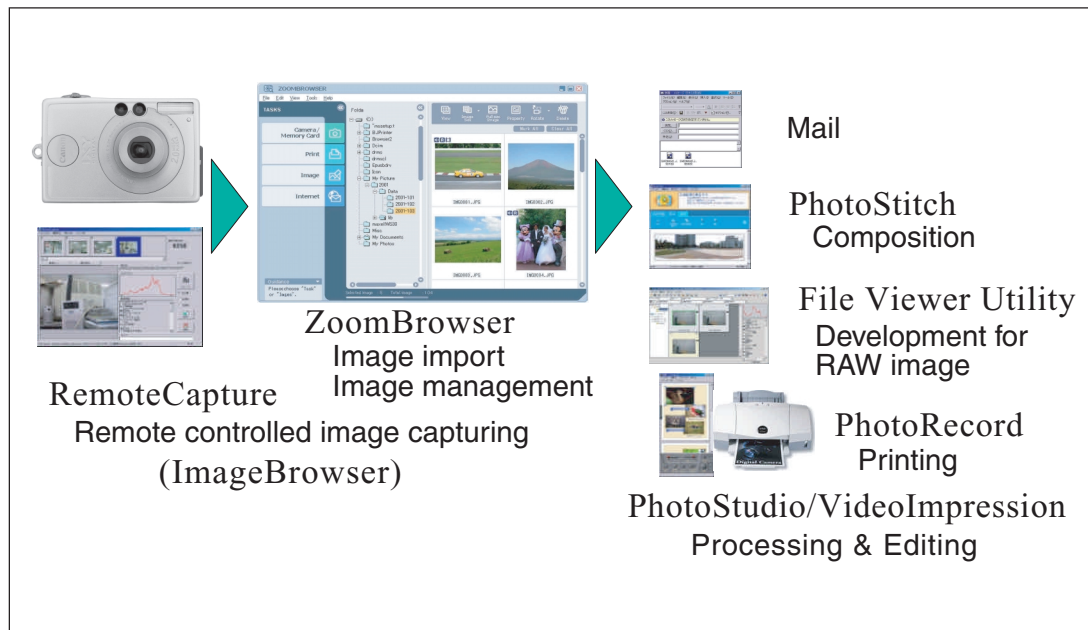

Figure 2-6 Organization of bundled applications

	<b>Windows</b>	<b>Macintosh</b>
Image management & display	ZoomBrowser EX 4.0	ImageBrowser 2.7
Prints for arranged images	PhotoRecord 1.6	
Composition of images	PhotoStitch 3.1	PhotoStitch 3.1
Remote controlled image capturing & export	RemoteCapture 2.6	RemoteCapture 2.6
Camera driver	TWAIN Driver 5.0 WIA Driver 5.0	USB Mounter 1.8
Development for RAW image	File Viewer Utility 1.0	File Viewer Utility 1.0
Movie playback	Apple Quick Time 5.0	-
Printer driver	CP-100/10 Printer Driver 2.1	CP-100/10 Printer Driver 2.1
for Printer driver's manual	Adobe Acrobat Reader 4.0	Adobe Acrobat Reader 4.0

Table 2-2 Bundled software content 1

	<b>Windows</b>	<b>Macintosh</b>
Image processing & editing (Still)	ArcSoft PhotoImpression 4.0	ArcSoft PhotoImpression 4.0
Image processing & editing (Mvie)	ArcSoft VideoImpression 1.7	ArcSoft VideoImpression 1.6

Table 2-3 Bundled software content 2

○ZoomBrowser EX 4.0 (Win) made more ergonomic

The ZoomBrowser EX 4.0 makes a vast improvement in usability from previous ZoomBrowser EX versions, featuring an updated user interface. (The previous ImageBrowser Ver. 2.7 is bundled for use with Macintosh computers.)

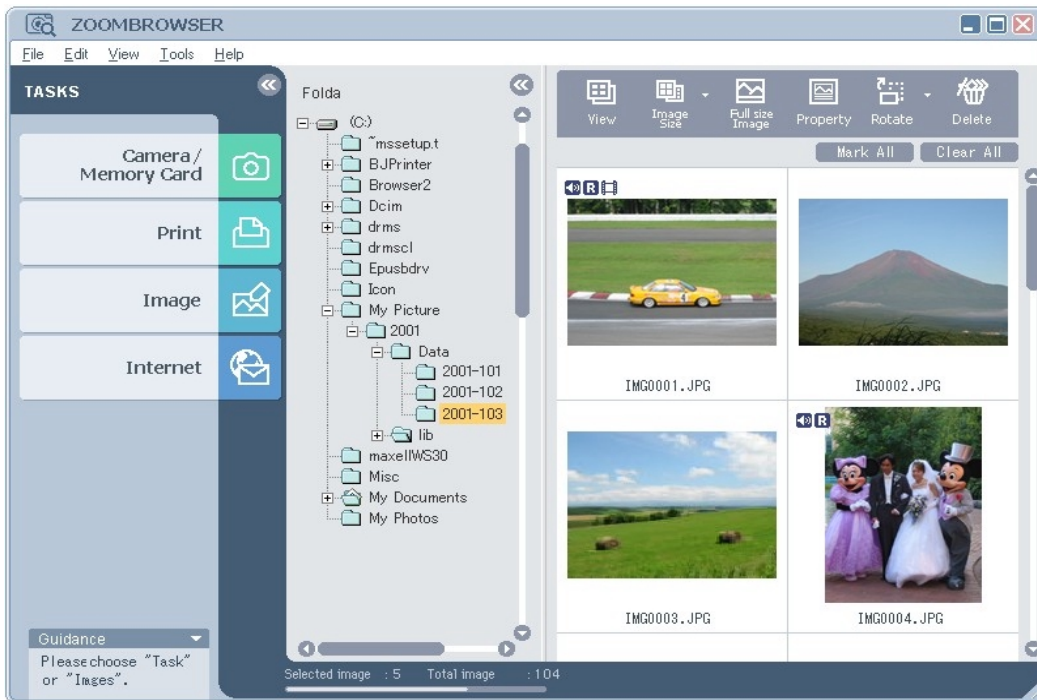

Figure 2-7 Main ZoomBrowser EX screen

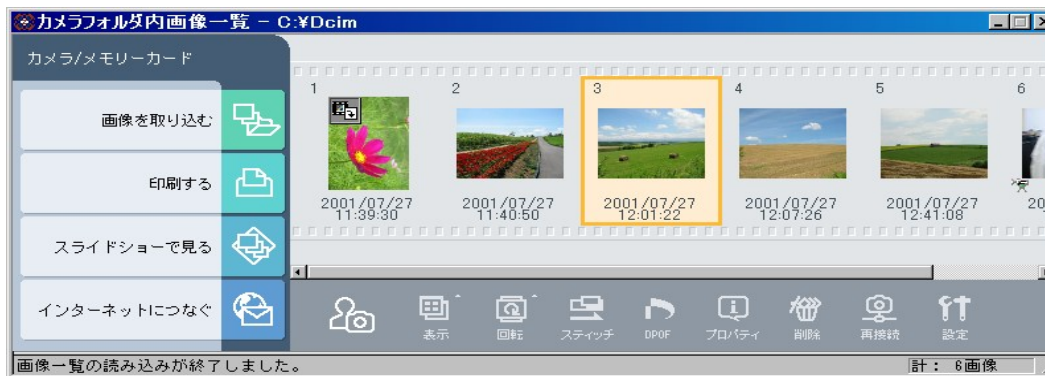

Figure 2-8 Image listing in ZoomBrowser EX (Japanese version)

## ■ Main improvements

### 1) Speed improvements

Changed to lighter, more compact database files

- Shorter launch time
- Quicker camera downloads
- Quicker thumbnail display of new images
- Shorter image delete and copy times

### 2) Improved database file reliability

- Revamped database construction
- Database is separated and saved as folders

### 3) File maintenance function improvements

Images displayed by selecting arbitrary folders

- Previous image folder registration operation unnecessary

Automatic update of image display

- Actual image file is checked automatically when displaying images within a folder

### 4) Unification of user operation procedures

Larger buttons make primary functions into explicit tasks

Unified task procedures

- All steps of an operation are shown and the current step is indicated
- Step-to-step operation works in Wizard fashion

Automatic selection of camera connection

- Same button is pressed for either camera connections or card reader connections

## ■ Other improvements in the user interface

### 1) Zoom mode, scroll mode, tool buttons

### 2) Easy-to-understand selection of multiple images

Multiple images are selected by repeating a single click (default setting)

### 3) Property window

Displays information on the selected image

Possible to add and select with floating windows

## ■ Other improvements

### 1) Addition of function to save the camera's My Camera settings on computer

### 2) Installer converted to Windows Installer

Improved localization workability

## ■ Discontinued functions

### 1) Deleted TWAIN interface

Eliminates automatic launch problem with Windows Me

### 2) Deleted TimeTunnel viewer

### 3) Support for 256 screen colors discontinued

○ File Viewer Utility 1.0 (support for Mac OS X at a later date)

From this release on, File Viewer Utility will be included in place of the previous RAW Image Converter

■ The following are the main functions and features:

- 1) Parameters for RAW images such as white balance, contrast, color intensity and sharpness can be set
- 2) User interface supports all camexras regardless of common interfaces

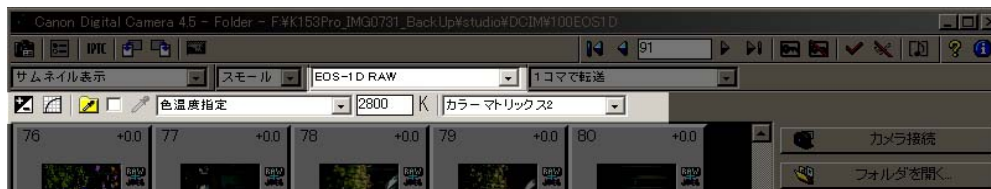

<EOS DIGITAL type>



<PowerShottype>

Figure 2-9 Parameter setup window

- 3) Possible to select various image display methods  
“Thumbnail/Preview/JPEG Preview” X “Large/Medium/Small”
- 4) Fast preview of RAW images  
Fast previews taking advantage of JPEG images without developing RAW images
- 5) Various displays  
RGB at cursor position
- 6) Extension of viewable formats  
File formats generated by cameras (JPEG-DCF, RAW)  
File formats generated by File Viewer Utility (TIFF-Exif, TIFF 16 bit)

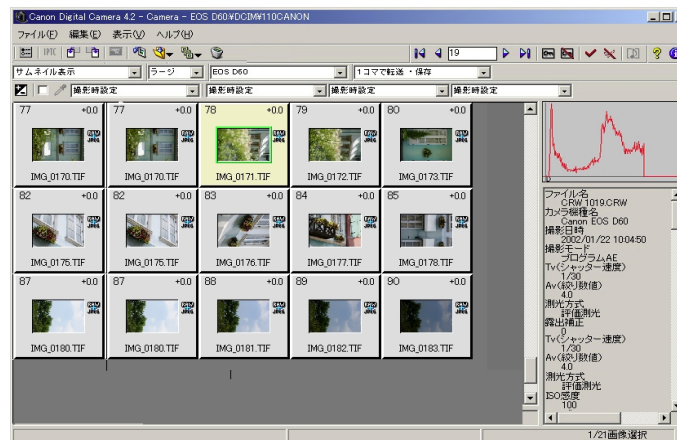

Figure 2-10 Main File Viewer Utility screen

○ **PhotoRecord 1.6 (Win) for easy layout and printing of clear pictures**

Adds support for Exif 2.2 to previous version

○ **PhotoStitch 3.1 for creating precise panoramic pictures**

Unchanged from previous version in terms of usability

○ **RemoteCapture 2.6 for image captures and image transfers controlled from computer**

The following are the changes from the previous version:

- 1) Moved to software without device information to support new firmware and new SDKs  
Abandoned device-specific recording windows and made one window for all devices
- 2) Added specifications  
Enhanced manual setting items (M, Av, Tv, AE selection, flash strength setting, flash exposure compensation setting)

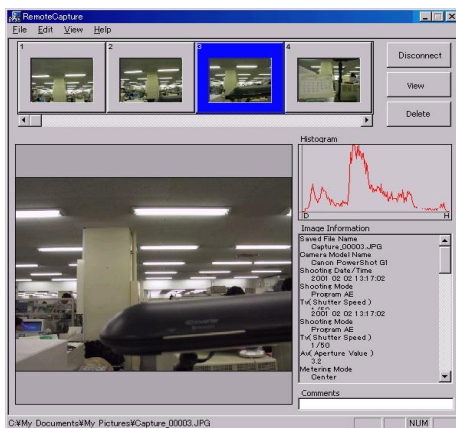

Figure 2-11 Parameter setup window in RemoteCapture

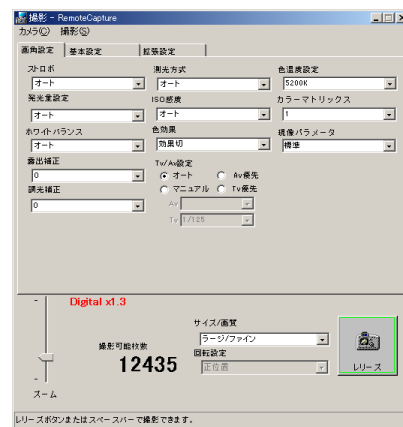

Figure 2-12 Main RemoteCapture screen

○ **TWAIN Driver 5.0/WIA Driver 5.0 (Win)**

Function limited to importing PEG images

○ **USB Mounter 1.6 (Mac, however only supports OS 9 to OS 9.2)**

Unchanged from previous version in terms of usability

○ **Apple QuickTime 5.0 (Win)**

Unchanged from previous version in terms of usability

○ **CP-10/100 PrinterDriver 2.1**

Adds support for CP-100 from this release on

○ **Adobe Acrobat Reader 4.0**

Bundled for use with printer driver PDF manuals

### 3 Exterior

#### 3-1 Exterior Photos



Photo 3-1 IXY DIGITAL 320 Front  
(Opend lens)



Photo 3-2 IXY DIGITAL 320 Front



Photo 3-3 IXY DIGITAL 320 Top

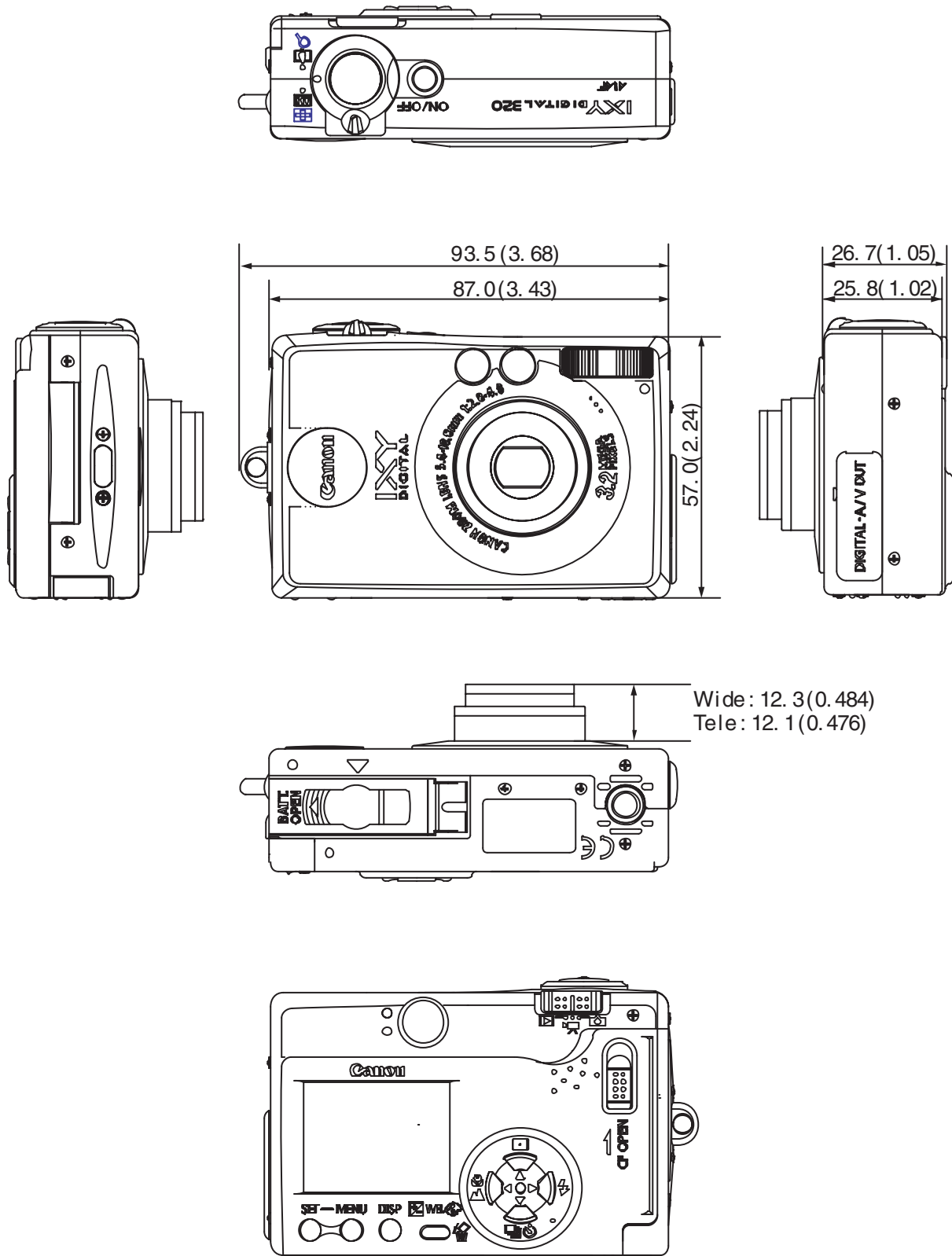

Photo 3-4 IXY DIGITAL 320 Side



Photo 3-5 IXY DIGITAL 320 Rear

3-2 6-dimensional diagram



unit : mm (inch)

### 3-3 Nomenclature

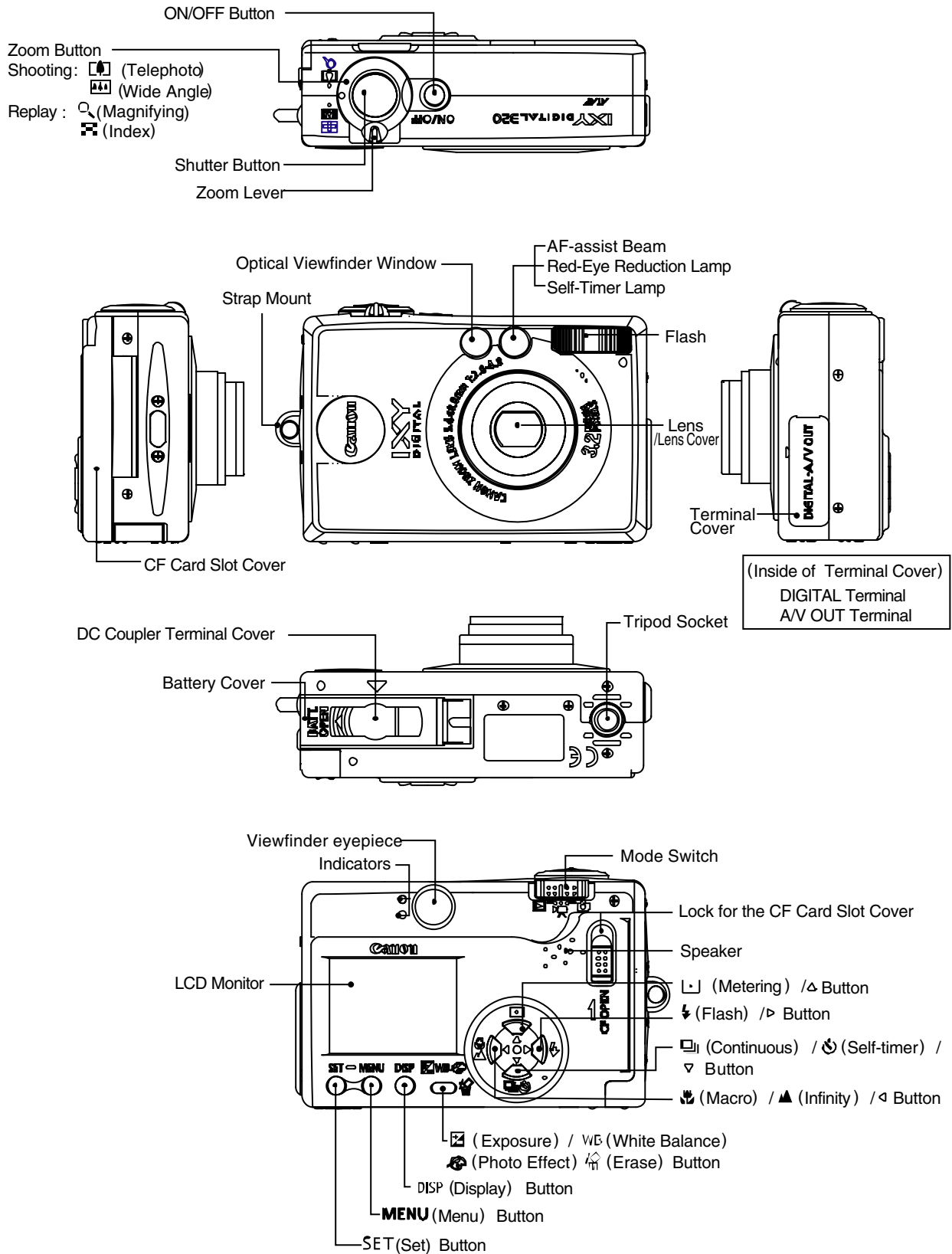



### 3-4 UI Information

#### -Screens for Shooting

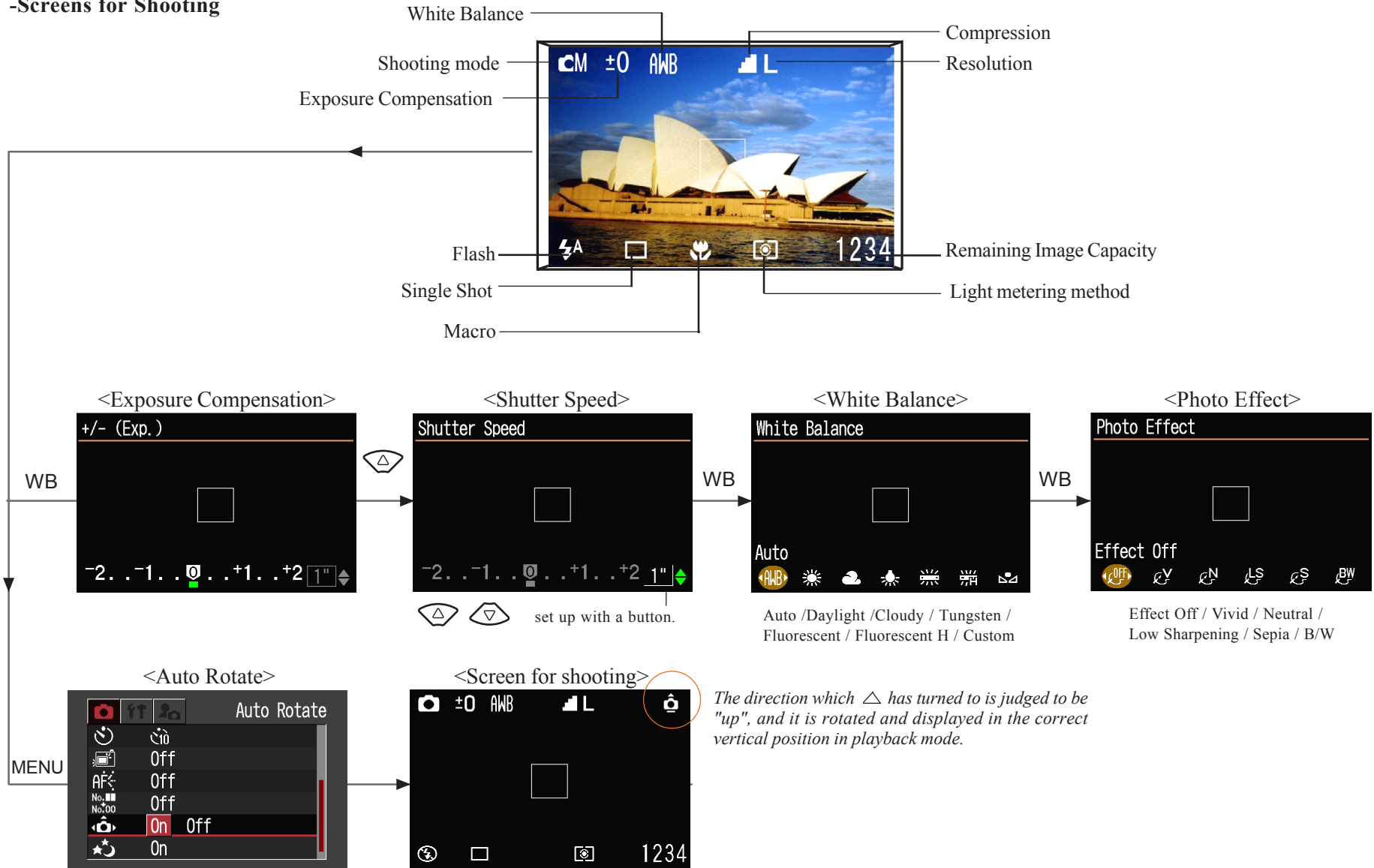

## -Editing Movies



## -Setting the Printing Area (Trimming)

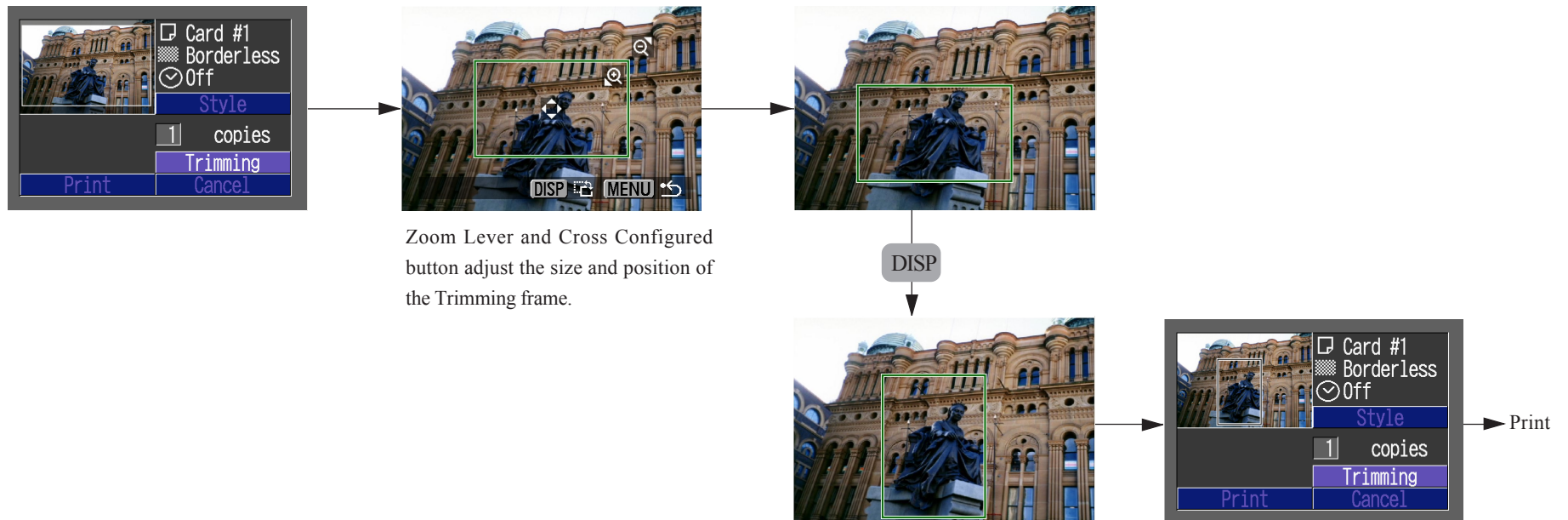

## 4 Specifications

### 4-1 Camera Specifications

#### ■ Image sensor (CCD)

Camera effective pixels (W x H)	Approx. 3.2 million (2,080 x 1,542)
Total pixels (W x H)	Approx. 3.3 million (2,140 x 1,560)
Reading format	Interline
Chip size (W x H)	1/2.7-inch size 5.36 x 4.05 mm (0.21 x 0.16 inch)
Unit cell size (W x H)	2.575 x 2.575 micron
Filter array	Primary color filter (Beyer)

#### ■ Lens

Focal length	5.4 (W) - 10.8 (T) mm (35mm film equivalent : 35 (W) - 70 (T) mm)
f/number	F2.8 (W) - 4.0 (T)
Lens construction	7 elements in 5 groups (including 3 aspherical lens)
Optical zoom	2x
Shooting distance (Measured from tip of the lensbarrel)	Normal AF : 47 cm (1.5 ft.) - infinity Macro AF : 10 - 47 cm (0.33 x 1.5 ft) (W) 27 - 47 cm (0.89 x 1.5 ft) (T) Landscape : 5.0 m (17 ft.) - infinity
Max. shooting area (W x H)	Wide : 102 x 76 mm (4.0 x 3.0 inch) Tele : 138 x 103 mm (5.4 x 4.1 inch)

#### ■ Optical viewfinder

Type	Real-image optical zoom viewfinder
Coverage	Vertical : 82 % Horizontal : 82 %
Eyepoint	16 mm

### ■ LCD monitor

Type	Low-temperature polycrystalline silicon TFT color LCD
Effective pixels (W x H)	Approx. 118 K- Pixels (490 x 240)
Display size	38 mm diagonal (1.5 inch)
Coverage	100 %

### ■ Focusing

Control system	TTL AiAF/TTL AF (AF lock is available: By pressing the shutter button halfway)
Focusing point	9 points (TTL AiAF) / 1 point on center (TTL AF)

### ■ Exposure control

Metering modes	Evaluation (AF point linked) / Spot
Exposure control system	Program AE (AE lock is available.)
Exposure compensation	+/- 2 stops in 1/3-stop increments
Sensitivity (Equivalent film speed)	Auto / ISO 50/100/200/400 equivalent

### ■ White balance

Mode	TTL auto white balance / Pre-set white balance (Daylight / Cloudy / Tungsten / Fluorescent / Fluorescent H) / Custom white balance
------	--

## ■ Shutter and aperture

Shutter type  
Aperture type

Mechanical shutter and electronic shutter  
Round shaped diaphragm

Shutter speed

15 - 1/1,500 sec.  
• 1/6 - 1 sec. shutter speed is only available with the flash off or slow sync. at Manual mode.  
• 1 - 15 sec. is available with  $\Delta \nabla$  button in long shutter mode at Manual mode.

f/number

F2.8/7.2 (W), AF4.0/10.0 (T)

## ■ Flash (Built-in)

Operation mode

Autoflash / Red-eye reduction auto / Flash On/Flash Off / Slow-syncro.

Flash range

(When sensitivity is set to ISO 100 equivalent.)  
Normal : (W) 47cm - 3.0 m (1.5 - 9.8 ft.)  
(T) 47cm - 2.0 m (1.5 - 6.6 ft.)  
Macro : 27 - 47cm (0.89 - 1.5 ft.)

Flash sync speed

15 - 1, 1/60 - 1/500 sec.

Recycling time

10 sec. or shorter (full flash, battery voltage = 3.7V)

Flash exposure compensation

+/- 2 stops in 1/3-stop increments

Functions

FE lock

## ■ Shooting specifications

Shooting modes

Auto / Manual / Stitch assist / Movie

Shooting function

Digital zoom

Maximum 3.2x (Maximum of approx. 6.4x zoom is available when combined with optical zoom.)

Photo effects

Vivid color / Neutral color / Low sharpening / Sepia / Black & White

Noise reduction

When shutter speed is set between 1.3 - 15 sec. .

Rec-review

Off, 2 - 10sec. (Can be set to each 1 sec. unit)

Camera power-up time

/ Release time lag

Mode	Finder	Camera power-up time (sec)	Shutter time lag (sec)
Shooting	LCD monitor On	2.8	0.07
	LCD monitor Off	1.9	0.05
Replay	-	2.2	-

\* Varies with shooting modes

Shooting interval

Shooting Mode	Finder	N/M	Lens Position	Shooting Interval (sec)	
Auto	LCD monitor On	Normal	Wide	2.1	
			Tele	2.2	
		Macro	Wide	2.7	
			Tele	2.2	
	AF Lock				1.7
	LCD monitor Off	Normal	Wide	1.7	
			Tele	1.8	
		Macro	Wide	2.1	
Tele			1.8		

\* The actual shooting interval is the shutter speed added to the above data.

Continuous shooting

Number of shots per second

Approx. 2.0 images / sec.

(Large (2048 x 1536) / Fine mode and LCD viewfinder is Off)

Maximum burst

Resolution/ Compression rate	L/SF	L/F	L/N	M1/SF	M1/F	M1/N	M2/SF	M2/F	M2/N	S/SF	S/F	S/N
Maximum number of shots	7	12	23	11	19	37	18	32	60	41	64	64

- The above data is the maximum with each “resolution / compression” mode. (64 is the maximum)
- While achieving the maximum number of shots, continuous shooting is available. However burst speed will go down.

Self-timer

Shutter release from PC

Operates with approx. 2 sec. or approx. 10 sec. countdown.

Use of “RemoteCapture” software (enclosed) during USB camera connection.

## ■ Recording specifications

### <Still image>

File format

Design rule for Camera File system

Digital Print Order Format (DPOF) Version 1.1 compliant

Image recording format

JPEG (Exif 2.2)

JPEG compression mode

Super fine / Fine / Normal

Number of recording pixels

Large : 2048 x 1536    Middle1 : 1600 x 1200

Middle2 : 1024 x 768    Small : 640 x 480

### Recording capacity

	L/SF	L/F	L/N	M1/SF	M1/F	M1/N	M2/SF	M2/F	M2/N	S/SF	S/F	S/N
File Size	1602 KB	893 KB	445 KB	1002 KB	558 KB	278 KB	570 KB	320 KB	170 KB	249 KB	150 KB	84 KB
FC-8M	4	8	16	7	13	26	12	23	42	29	47	83
FC-16M	8	16	32	14	26	52	25	46	84	58	94	165
FC-32M	18	33	67	30	54	108	53	94	174	120	196	337
FC-64M	38	68	136	61	109	217	107	189	349	241	393	676
FC-128M	76	137	274	122	219	435	215	379	700	482	788	1355
FC-256MH	154	276	548	246	440	868	431	762	1390	962	1563	2720

### <Movie>

File format

AVI

Recording format

Image : Motion JPEG, Audio : FWAVE (Monaural)

Number of recording pixels

VGA : 640 x 480    QVGA : 320 x 240    QQVGA : 160 x 120

Frame rate / Shooting time

	Frame rate (fps)	Shooting time (min)
640 × 480	15	30
320 × 240	15	180
160 × 120	15	180

### Recording time\*

	640×480	320×240	160×120
File Size	990 KB/sec	330 KB/sec	120 KB/sec
FC-8M	7 "	22"	59"
FC-16M	14"	44"	118"
FC-32M	30"	91"	242"
FC-64M	61"	183"	486"
FC-128M	124"	368"	973"
FC-256MH	249"	735"	1954"

\* FC-256MH : There is some area which is not sold.

\* The above-written figures are measured under Canon's testing standard and may vary depending on the scene, subjects or camera settings.

### <Common>

Storage media

CompactFlash™ (CF) card (Type I)

Tone reproduction

JPEG : Luminance signal : 8 bits/Color signal (Cr/Cb) : 8 bits

## ■ Replay specifications

Replay mode

Single / Index (9 thumbnail images) / Magnification / Movie

<Still image>

Magnify

Vertical and horizontal conversion

Approx. 2 - 10x

Images are displayed vertically or horizontally according to the camera's shooting position. Also, vertical and horizontal conversion can be set for each image.

(Both LCD monitor and Video out play the image according to setting.)

Histogram display

Display luminance allocation of image.

(available on rec-review.)

Slide show

Interval between shots : 3 - 10 sec. 15 sec. 30 sec.

Manual setting

Repeat : On / Off

DPOF

Print order/Slide show/Image transfer

Direct print

Image output to dedicated printers (CP-100, CP-10) and BJ printer (BJ 895PD, 535PD, F890PD).

<Movie>

Special replay

Next frame / Previous frame / Fast forward / Rewind /  
First frame / Last frame

## ■ Erasing specifications

Erasing modes

Still images: Single image / All images

Movie : Part of images \* / All of images

The image data recorded on Design rule for Camera File system's format can be erased. However, protected images can't be erased.

\* Can be erased from start-point to mid-point or from mid-point to end-point with the movie editing function.

Furthermore, frames can be erased both from start-point to mid-point and from mid-point to end-point simultaneously.

Protection

Erase prohibited (Setting at replay mode)



## ■ Display specifications

Indicator (Upper)

Green :

Ready to record / Ready to communicate  
(during a computer connection)

Blinking Green :

During power-up camera / Recording to CF card / Reading  
CF card / Erasing from CF card / Transmitting data  
(during a computer connection)

Orange :

Ready to record (at Flash On)

Blinking Orange :

Ready to record (camera shake warning)

Indicator (Lower)

Yellow :

Macro mode / Landscape mode / Focus lock

Blinking Yellow :

Indicates that the focus goes to fixed point because the actual  
focus point is not found.

AF-assist beam

Lights :

Low-contrast objects, low-light conditions and red-eye  
reduction on while SW1 on.

Blinks :

During count down of self-timer.

The AF-assist Beam blinks at 2 Hz for the first 8 seconds and at  
8 Hz for the last 2 seconds (9th and 10th seconds) and then turns  
off. (If the red-eye reduction is on, it lights instead of blinking for  
the last 2 seconds.)

Power mode indicator

Green: Power On

Beep

Single sound (twice) : Ready to record

Single sound (once) : Button operations, complete shooting  
(shutter off) and warning of off-focus.

Single sound (6 times) : Warning (CF card full or not inserted  
in camera)

Continuous sound : Warning (CF card slot cover / battery  
cover was opened while recording to CF  
card.)

Intermittent sound : Count-down of self-timer.

\* Sounds (excluding when CF card slot cover/battery cover is  
open and CF card is not inserted in camera) can be set on or off.

## ■ Interface

Computer I/F

USB \* : Normal / PTP

A/V out

Video : NTSC/PAL

Audio : Monaural

## ■ Others

Languages

12 languages are available for menu and messages.  
English, German, French, Dutch, Danish, Finnish, Italian,  
Norwegian, Swedish, Spanish, Chinese and Japanese

## ■ Power supplies

Power sources

Rechargeable Lithium-ion battery (type: NB-1LH, NB-1L)

AC adapter

AC adapter (type: CA-PS500)

\* DC coupler (type: DR-500) is required.

Car battery adapter

Car battery adapter (type : CBC-NB1 <optional>)

Sub-battery

Unremoval

Shooting capacity

NB-1LH (full charge) :

LCD monitor On : Approx. 170 images

LCD monitor Off : Approx. 420 images

Normal temperature (23°C). LCD viewfinder is On. Shoot images at wide angle and at telephoto end alternately with 20 seconds intervals.

Use flash at every 4-time shooting. Turn camera off and on at every 8-times shooting.

Replay time

NB-1LH (full charge): Approx. 130 min.

Canon's standard conditions of measuring replay time are as follows:

Normal temperature (23°C). Repeat replay automatically at a speed of 1 image per 5 seconds.

Charging time

Approx. 130 min. (CB-2LS)

Power-saving function

Power-saving function is active with demanding on each mode when power-saving on the menu screen is "on".

<Shooting mode>

Powers down approximately 3 minutes after a control is last accessed.

(The LCD monitor will shut off approximately 3 minutes after a control is last accessed even if the power-saving function is turned off.)

<Replaying mode>

Powers down approximately 5 minutes after a control is last accessed.

<Printer connection>

Powers down approximately 5 minutes after a control is last accessed on the camera or something is printed on the printer.

<PC connection>

Displays a warning message on the computer screen approximately 5 minutes after a control is last accessed. The camera will be powered down if no controls are used after 1 additional minute.

(Available only when the communication setting is set to "normal" and power-saving function is "on".)

■ **Camera specifications**

Operating temperature

0 - 40°C

Operating humidity

10 - 90 %

Dimensions (W x H x D)

87.0 x 57.0 x 26.7 mm (3.4 x 2.2 x 1.1 inch)

(Excluding protrusion)

Weight

Approx. 180 g (6.35 oz) (Excluding batteries and CF card)

## ■ Functions Available in Each Shooting Mode

		Auto	Manual	Manual (long shutter)	Stitch Assist	Movie
Focus	AF frame: 9points (AiAF)	☉	☉	☉	☉	☉
	AF frame: 1point (center)	—	○	○	—	—
	AF lock	—	○	○	—	—
Exposure control	Spot AE point	—	○	—	—	—
	Exposure control	—	○	—	△	○
	ISO speed (AUTO)	☉	○	—	☉	☉
	ISO speed (50/100/200/400)	—	○*2	○*2	—	—
	AE lock	—	○	—	—	—
White balance		Auto only	○	○	△	○
Shutter	Tv value setting	—	—	○	—	—
Flash	Red-eye reduction ON	☉*3	☉	☉	—	—
	Autoflash	○*3	○	○	—	—
	Slow -sync.	—	○	○	△	—
	On	—	○	○	△	—
	Off	○*3	○	○	☉	—
	AF assist beam	○	○	○	○	○
Shooting specifications	Single shot	☉	☉	☉	☉	☉
	Continuous	—	○	○	—	—
	Self-timer (10/2 sec.)	○	○	○	△	○
	Normal shooting	☉	☉	☉	☉	☉
	Macro shooting	○	○	○	△	○
	Infinity shooting	—	○	○	△	○
	Digital zoom	○	○	○	—	—
	Photo effect	—	○	○	△	○
Vertical and horizontal conversion		○	○	○	△	—
Recording specifications	Recording pixels (L/M1/M2/S)	○	○	○	△	—
	Compression (SF/F/N)	○	○	○	△	—
Movie specifications	Recording pixels (VGA/QVGA/QQVGA)	—	—	—	—	○

Functions that are available or unavailable in all modes are not described in the upper table.

☉ : Default (set by mode change) ○ : selectable △ : selectable only for the first image

Values saved even PLAY ↔ REC are remembered.

 : Values saved even after shutdown are remembered.

\*1 Evaluation metering is the default.

\*2 ISO 50 is the default.

\*3 Only the red-eye reduction and auto are saved in auto mode. (Then shutdown with the flash off, system starts up with the previous flash mode which was selected red-eye reduction or auto.)

\*4 The setting of vertical and horizontal conversion is effective.

\*5 Large is the default.

\*6 Fine is the default.

\*7 QVGA is the default.

●Replay compatibility

		Replay cameras																			
		PS 350	PS A5/A5 Z	PS Pro70	PS A50	PS S10/S20	IXY DIGITAL	PS G1, Pro90 IS	EOS D30	IXY D 200/300	PS A10/A20	PS G2	PS S30/S40	PS A40/A30	PS A200/A100	ID 200a/300a	EOS D60	PS S45	PS G3	IXY D 320	
I m a g e t a k i n g c a m e r a s	PS 350	CFF	○	○	○	○	×	×	×	×	×	×	×	×	×	×	×	×	×	×	
	PS A5/A5 Z	CFF	△	○ *1	○ *1	○ *1	×	×	×	×	×	×	×	×	×	×	×	×	×	×	
	PS Pro70	CFF	△	○ *2	○ *1	○ *1	×	×	×	×	×	×	×	×	×	×	×	×	×	×	
	PS A50	CFF	△	○ *2	○ *1	○ *1	×	×	×	×	×	×	×	×	×	×	×	×	×	×	×
		DCF	×	×	×	○ *1	○ *1	○ *1	○ *1	○ *1	○ *1	○ *1	○ *1	○ *1	○ *1	○ *1	○ *1	○ *1	○ *1	○ *1	○ *1
	PS S10/S20	DCF	×	×	×	○ *3	○	○	○	○	○	○	○	○	○	○	○	○	○	○	○
	IXY DIGITAL	DCF	×	×	×	○	○	○	○	○	○	○	○	○	○	○	○	○	○	○	○
	PS G1	DCF (Still)	×	×	×	○ *1*3	○ *1	○ *1	○	○	○ *1	○ *1	○	○	○	○	○	○	○	○	○
		PS Pro90 IS (Movie)	×	×	×	▲	▲	▲	▲	○ *5	▲	○	○	○	○ *5	○ *5	○ *5	▲	○	○	○
	EOS D30	DCF	×	×	×	○ *1*3	○ *1	○ *1	○	○	○ *1	○ *1	○	○	○	○	○	○	○	○	○
		IXY DIGITAL 200/300 (Movie)	×	×	×	▲	▲	▲	○ *6	▲	○	▲	○	○	○	○ *5*6	○	▲	○	○	○
	PS A10/A20	DCF	×	×	×	○	○	○	○	○	○	○	○	○	○	○	○	○	○	○	○
		DCF (Still)	×	×	×	○ *1*3	○ *1	○ *1	○	○	○ *1	○ *1	○	○	○	○	○	○	○	○	○
	PS G2	DCF (Still)	×	×	×	▲	▲	▲	○ *5*6	▲	○ *5*6	▲	○	○	○ *5*6	○ *5*6	○ *5*6	▲	○	○	○
		(Movie)	×	×	×	▲	▲	▲	○ *5*6	▲	○ *5*6	▲	○	○	○ *5*6	○ *5*6	○ *5*6	▲	○	○	○
	PS S30/S40	DCF (Still)	×	×	×	○ *1*3	○ *1	○ *1	○	○	○ *1	○ *1	○	○	○	○	○	○	○	○	○
		(Movie)	×	×	×	▲	▲	▲	○ *5*6	▲	○ *5*6	▲	○	○	○ *5*6	○ *5*6	○ *5*6	▲	○	○	○
	PS A40/A30	DCF (Still)	×	×	×	○	○	○	○	○	○	○	○	○	○	○	○	○	○	○	○
		(Movie)	×	×	×	▲	▲	▲	○ *6	▲	○ *5	▲	○	○	○	○ *5*6	○	▲	○	○	○
	PS A200/A100	DCF (Still)	×	×	×	○	○	○	○	○	○	○	○	○	○	○	○	○	○	○	○
(Movie)		×	×	×	▲	▲	▲	○ *6	▲	○ *5	▲	○	○	○	○	○	▲	○	○	○	
ID 200a/300a	DCF (Still)	×	×	×	○	○	○	○	○	○	○	○	○	○	○	○	○	○	○	○	
	(Movie)	×	×	×	▲	▲	▲	○ *6	▲	○	▲	○	○	○	○ *5*6	○	▲	○	○	○	
EOS D60	DCF	×	×	×	○ *1*3	○ *1	○ *1	○	○	○ *1	○ *1	○	○	○	○	○	○	○	○	○	
	DCF (Still)	×	×	×	○ *1*3	○ *1	○ *1	○	○	○ *1	○ *1	○	○	○	○	○	○	○	○	○	
PS S45	DCF (Still)	×	×	×	○ *1*3	○ *1	○ *1	○	○	○ *1	○ *1	○	○	○	○	○	○	○	○	○	
	(Movie)	×	×	×	▲	▲	▲	○ *5*6	▲	○ *5*6	▲	○ *5*6	○ *5*6	○ *5*6	○ *5*6	○ *5*6	▲	○	○	○ *5*6	
PS G3	DCF (Still)	×	×	×	○ *1*3	○ *1	○ *1	○	○	○ *1	○ *1	○	○	○	○	○	○	○	○	○	
	(Movie)	×	×	×	▲	▲	▲	○ *5*6	▲	○ *5*6	▲	○ *5*6	○ *5*6	○ *5*6	○ *5*6	○ *5*6	▲	○	○	○ *5*6	
ID 320	DCF (Still)	×	×	×	○ *3	○	○	○	○	○	○	○	○	○	○	○	○	○	○	○	
	(Movie)	×	×	×	▲	▲	▲	○ *5*6	▲	○ *5*6	▲	○ *5*6	○ *5*6	○ *5*6	○ *5*6	○ *5*6	▲	○	○	○	
Other DCF cameras	DCF (Still)	×	×	×	○ *3	○ *4	○ *4	○ *4	○ *4	○ *4	○ *4	○ *4	○ *4	○ *4	○ *4	○ *4	○ *4	○ *4	○ *4	○ *4	
	(Movie)	×	×	×	▲	▲	▲	▲	▲	▲	▲	▲	▲	▲	▲	▲	▲	▲	▲	▲	

IXY DIGITAL 320 supports 3200(H) x 2400(V) pixels.

- : Replayable
- △ : Impossible to replay RAW images
- ▲ : Thumbnail display AVI main image with thumbnail (.thm) only
- × : Not replayable

\*1: Thumbnail display of RAW mode images.  
 \*2: Thumbnail display of RAW mode images. JPEG file replay up to 1,024 x 768 pixels.  
 \*3: Only JPEG file replay.  
 Replayable up to 1,632 x 1,232 pixels. With images larger than the thumbnail display (160 x 120) size, the "Image too large" message is displayed.  
 \*4: Only JPEG file replay.  
 Replayable up to 3,200 x 2,400 pixels. With images larger than the thumbnail display (160 x 120) size, the "Image too large" message is displayed.

\*5: "Image too large" message is displayed when the file size exceeds fixed capacity.  
 \*6: "Corrupted data" message is displayed when a movie's play time exceeds time limit.

Since the following camera's RAW function has an internal JPEG file for playback, a full screen image is displayed. However, if the RAW images from the PS A50 and previous models are played back with the following camera, thumbnails will be displayed.  
 \* PS G1/G2/G3/S30/S40/S45/Pro90 IS, EOS D30/D60/1D

## 4-2 System Requirements

	Windows	Macintosh
Computer Model	IBM PC/AT compatible	Power Macintosh, PowerBook, iMac, iBook
OS	Windows 98 (including Second Edition)/Me/2000/XP - TWAIN Driver is compatible with Windows 98/2000. - WIA Driver is compatible with Windows Me/XP.	Mac OS 8.6 - 9.2 and Mac OS X 10.1 - Mac OS X does not support UFS (Unix File System). - File Viewer Utility is not supported by Mac OS X. - USB Mounter is compatible only with Mac OS 9.0 - 9.2.
CPU	Windows 98/Me/2000: Pentium 150 MHz or better Windows XP: Pentium 300 MHz or better	PowerPC
Memory (RAM)	Windows 98/Me/2000: 64 MB or more Windows XP: 128 MB or more	Mac OS 8.6 - 9.2 : 20 MB or more of application memory Mac OS X 10.1 : 128 MB or more of RAM
Free hard disk space  Capacity for installation	ZoomBrowser EX 4.0/PhotoRecord 1.6 : 120 MB or more PhotoStitch 3.1 : 40 MB or more File Viewer Utility 1.0 : 100 MB or more RemoteCapture 2.6 : 20 MB or more TWAIN Driver 5.0 : 25 MB or more WIA Driver 5.0 : 25 MB or more CP-100/CP-10 Printer Driver 2.1 : 1 MB or more* ArcSoft PhotoImpresion 4 : 275 MB or more ArcSoft VideoImpresion 1.7 : 200 MB or more	ImageBrowser 2.7 : 20 MB or more PhotoStitch 3.1 : 30 MB or more File Viewer Utility 1.0 : 100 MB or more RemoteCapture 2.6 : 15 MB or more USB Mounter 1.8 : 5 MB or more CP-100/CP-10 Printer Driver 2.1 : 3.8 MB or more* ArcSoft PhotoImpresion 4 : 275 MB or more ArcSoft VideoImpresion 1.6 : 100 MB or more
USB interface	USB: Only preinstalled Windows 98/Me/2000/XP systems with built-in USB ports.	USB: Only systems equipped with genuine Apple-brand built-in USB interfaces.
Display	800 × 600 pixels High Color (16-bit) or more required (1,024 × 768 pixels or more recommended)	800 × 600 pixels 32,000 colors or more required (1,024 × 768 pixels or more recommended)
Sound card	Required to play movie sound	
Others	Apple QuickTime 3.0 or higher is required to play movies and save/play QuickTime VR. (Apple QuickTime 5.0 is included.)	

## 5 System

### 5-1 Accessories Compatibility

	PS G3	I D 200a I D 300a I D 320	PS A200 PS A100	PS A40 PS A30	PS S30 PS S40 PS S45	PS G2	IXY D 200	IXY D 300	PS A20 PS A10	IXY DIGITAL	PS Pro 90 IS	PS G1	PS S10 PS S20	PS Pro70	PS A5 Z PS A50	PS A5
<b>&lt;Battery&gt;</b>																
NB-5H	-	-	-	-	-	-	-	-	-	-	-	-	O	-	O	O
NB-4H	-	-	-	-	-	-	-	-	-	-	-	-	-	O	-	-
NB-1L	-	O	-	-	-	-	O	O	-	O	-	-	-	-	-	-
BP-511	O	-	-	-	-	O	-	-	-	-	O	O	-	-	-	-
BP-512	O	-	-	-	-	O	-	-	-	-	-	-	-	-	-	-
NB4-100	-	-	O*1	O	-	-	-	-	O	-	-	-	-	-	-	-
NB-2L	-	-	-	-	O	-	-	-	-	-	-	-	-	-	-	-
NB-1LH	-	O	-	-	-	-	O	O	-	O	-	-	-	-	-	-
*1: 2 sets of 2 batteries (4 battery packages).																
<b>&lt;Adapter/Charger&gt;</b>																
CA-PS100/100E	-	-	-	-	-	-	-	-	-	-	-	-	O	-	O	O
CA-PS200	-	-	-	-	-	-	-	-	-	-	-	-	-	O	-	-
CA-PS300	-	-	-	-	-	-	-	-	-	O	-	-	-	-	-	-
CA-PS500	-	O	-	-(O)*2	-	-	O	O	-(O)*2	O	-	-	-	-	-	-
CA-560	O	-	-	-	-	O	-	-	-	-	O	O	-	-	-	-
CR-560	O	-	-	-	-	O	-	-	-	-	O	O	-	-	-	-
CA-PS800	-	-	O	-	-	-	-	-	-	-	-	-	-	-	-	-
CB-2L/2LE	-	-	-	-	-	-	-	-	-	O	-	-	-	-	-	-
CB-2LS/2LSE	-	O	-	-	-	-	O	O	-	-	-	-	-	-	-	-
CB-3AH	-	-	O*3	O	-	-	-	-	O	-	-	-	-	-	-	-
CBK100	-	-	O*3	O	-	-	-	-	O	-	-	-	-	-	-	-
CB-2LT/CB-2LTE	-	-	-	-	O	-	-	-	-	-	-	-	-	-	-	-
CBC-NB1	-	O	-	-	-	-	O	O	-	-	-	-	-	-	-	-
CBC-NB2	-	-	-	-	O	-	-	-	-	-	-	-	-	-	-	-
*2: It is possible to use by inserting the adapter's DC plug in the jack of PS A40/A30/A20/A10 cameras directly without using DC coupler.																
*3: 4 batteries (2 set of 2) can be recharged.																
<b>&lt;DC Coupler&gt;</b>																
DR-100/100A	-	-	-	-	-	-	-	-	-	-	-	-	O	-	O	O
DR-200	-	-	-	-	-	-	-	-	-	-	-	-	-	O	-	-
DR-300	-	-	-	-	-	-	-	-	-	O	-	-	-	-	-	-
DR-500	-	O	-	-	-	-	O	O	-	-	-	-	-	-	-	-
DR-700	-	-	-	-	O	-	-	-	-	-	-	-	-	-	-	-
<b>&lt;Lens Accessory&gt;</b>																
WC-DC58	-	-	-	-	-	O	-	-	-	-	O	O	-	-	-	-
WC-DC52	-	-	-	O	-	-	-	-	O	-	-	-	-	-	-	-
WC-DC58N	O	-	-	-	-	-	-	-	-	-	-	-	-	-	-	-
TC-DC58	-	-	-	-	-	O	-	-	-	-	-	O	-	-	-	-
TC-DC58N	O	-	-	-	-	-	-	-	-	-	-	-	-	-	-	-
250D 58mm	O	-	-	-	-	O	-	-	-	-	-	O	-	-	-	-
500D 58mm	-	-	-	-	-	-	-	-	-	-	O	-	-	-	-	-
250D 52mm	-	-	-	O	-	-	-	-	O	-	-	-	-	-	-	-
LA-DC58	-	-	-	-	-	O	-	-	-	-	-	O	-	-	-	-
LA-DC52	-	-	-	-	-	-	-	-	O	-	-	-	-	-	-	-
LA-DC58N	O	-	-	-	-	-	-	-	-	-	-	-	-	-	-	-
LH-DC58	-	-	-	-	-	-	-	-	-	-	O	-	-	-	-	-
TC-DC52	-	-	-	O	-	-	-	-	O	-	-	-	-	-	-	-
LA-DC52B	-	-	-	O	-	-	-	-	-	-	-	-	-	-	-	-

<Speed Lite>

220EX	O	-	-	-	-	-	O	-	-	-	-	-	O	O	-	O	-	-
380EX	O	-	-	-	-	-	O	-	-	-	-	-	O	O	-	O	-	-
550EX	O	-	-	-	-	-	O	-	-	-	-	-	O	O	-	-	-	-
420EX	O	-	-	-	-	-	O	-	-	-	-	-	O	O	-	-	-	-
(MR-14EX)	O	-	-	-	-	-	O	-	-	-	-	-	O	O	-	-	-	-
(MT-24EX)	O	-	-	-	-	-	O	-	-	-	-	-	O	O	-	-	-	-

<Remote Sw itch>

WL-DC100	O	-	-	-	-	-	O	-	-	-	-	-	O	O	-	-	-	-
RS-8N3	-	-	-	-	-	-	-	-	-	-	-	-	-	-	-	O	-	-

<Cable, Others>

VC-100	-	-	-	O*4	-	-	-	-	-	O*5	-	-	-	-	O	O	O	O
VC-200	-	-	-	-	-	-	-	-	-	-	O	-	-	-	-	-	-	-
AVC-DC100	O	O(300a)	-	O*6	O	O	-	O	-	-	O	O	O	-	-	-	-	-
AVC-DC200	-	O(200a/320)	-	-	-	-	O	-	-	-	-	-	-	-	-	-	-	-
IFC-100PCS	-	-	-	-	-	-	-	-	-	-	-	-	-	-	-	O	O	O
IFC-100MC	-	-	-	-	-	-	-	-	-	-	-	-	-	-	-	O	O	O
IFC-200PCS	-	-	-	-	-	-	-	-	-	-	-	O	O	O	O	-	-	-
IFC-200PCU	O	O(200a/320)	-	-	-	-	O	O	-	-	O	O	O	O	-	-	-	-
IFC-200MC	-	-	-	-	-	-	-	-	-	-	-	O	O	O	O	-	-	-
IFC-300PCU	-	O(300a)	O	O	O	-	-	O	O	-	-	-	-	-	-	-	-	-
AD-PC98	-	-	-	-	-	-	-	-	-	-	-	O	O	O	O	O	O	O
DIF-100	O	O(300a)	O	O	O	O	-	O	O	-	-	-	-	-	-	-	-	-
DIF-200	-	O(200a/320)	-	-	-	-	O	-	-	-	-	-	-	-	-	-	-	-

\*4: PS A30 only

\*5: PS A20 only

\*6: PS A40 only

<Case>

SC-PS100	-	-	-	-	-	-	-	-	-	-	-	-	-	-	O	-	O	O
SC-PS300	-	O(200a/320)	-	-	-	-	O	-	-	-	O	-	-	-	-	-	-	-
SC-PS400	-	-	-	-	-	-	-	-	-	-	-	-	O	-	-	-	-	-
SC-PS500	-	O(300a)	-	-	-	-	-	-	O	-	-	-	-	-	-	-	-	-
SC-PS600	-	-	-	O	-	-	-	-	O	-	-	-	-	-	-	-	-	-
SC-PS700	-	-	-	-	-	O	-	-	-	-	-	-	-	-	-	-	-	-
SHC-PS200	-	-	-	-	-	-	-	-	-	-	-	-	-	-	O	-	-	-
SHC-PS300	-	-	-	-	-	-	-	-	-	-	O	-	-	-	-	-	-	-
SC-PS800	-	-	-	-	O	-	-	-	-	-	-	-	-	-	-	-	-	-
SC-PS900	-	-	-	O	-	O	-	-	-	-	-	-	-	-	-	-	-	-
SC-DC10	O	-	-	-	-	-	-	-	-	-	-	-	-	-	-	-	-	-

<All Weather Case / Waterproof Case>

AW-PS100	-	-	-	-	-	-	-	-	-	-	-	-	-	-	-	-	-	O
AW-PS110	-	-	-	-	-	-	-	-	-	-	-	-	-	-	-	-	-	-
AW-PS200	-	-	-	-	-	-	O	-	-	-	O	-	-	-	-	-	-	-
WP-DC100	-	-	-	-	-	-	-	O	-	-	-	-	-	-	-	-	-	-
WP-DC200	-	-	-	-	-	-	-	-	-	O	-	-	-	-	-	-	-	-
WP-DC300	-	-	-	-	O	-	-	-	-	-	-	-	-	-	-	-	-	-
WP-DC200s	-	-	-	O	O	-	-	-	-	O	-	-	-	-	-	-	-	-
WP-DC400	-	-	O	-	-	-	-	-	-	-	-	-	-	-	-	-	-	-
WP-DC500	-	O(300a)	-	-	-	-	-	-	-	-	-	-	-	-	-	-	-	-
WP-DC600	-	O(200a)	-	-	-	-	-	-	-	-	-	-	-	-	-	-	-	-



5-2 System diagram

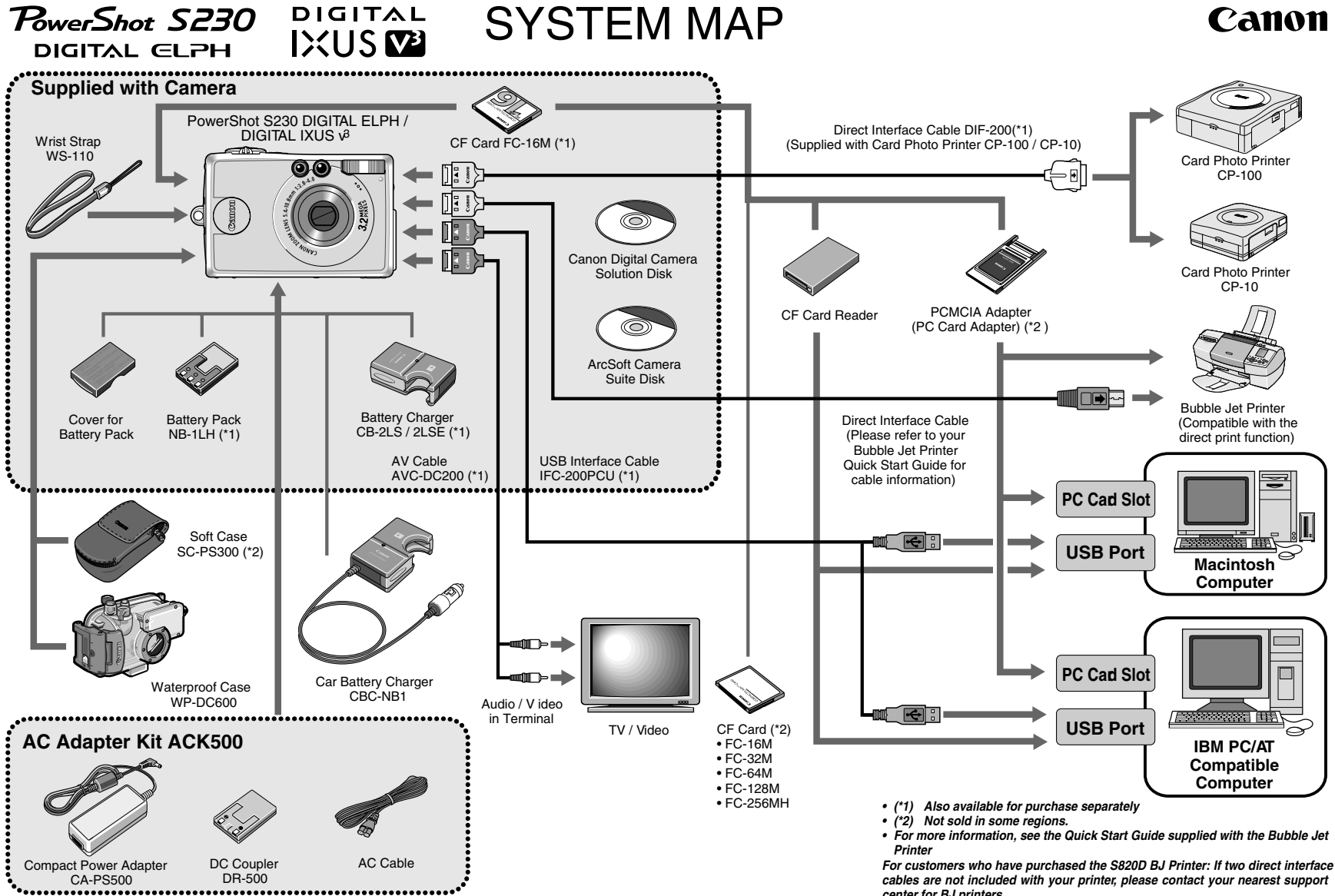

- (\*1) Also available for purchase separately
- (\*2) Not sold in some regions.
- For more information, see the Quick Start Guide supplied with the Bubble Jet Printer

For customers who have purchased the S820D BJ Printer: If two direct interface cables are not included with your printer, please contact your nearest support center for BJ printers.

## 6 Additional Guidance

### 6-1 iSAP (intelligent Scene Analysis based on Photographic Space) Technology

An important role of copiers and scanners is to **faithfully** reproduce the image quality of the original. With digital cameras, on the other hand, it is essential to regenerate captured images **naturally**.

However, attempting to faithfully reproduce a captured image does not always result in a natural image. This is why **image rendering**, an inherent technology of digital cameras, is so important to digital photography.

Image rendering is the inclusion of several elements including ‘exposure control appropriate to the scene => auto exposure (AE)’, ‘color reproduction based on human sense → addition of memorized colors’, ‘faithful color reproduction independent of background colors/color reproduction that compensates for the color temperature of the light source → auto white balance (AWB)’ and ‘tone representation that looks natural to the eye →  $\gamma$  characteristic’. Obviously, image rendering assumes that ‘precise focus control → auto focus (AF)’ is performed as well.

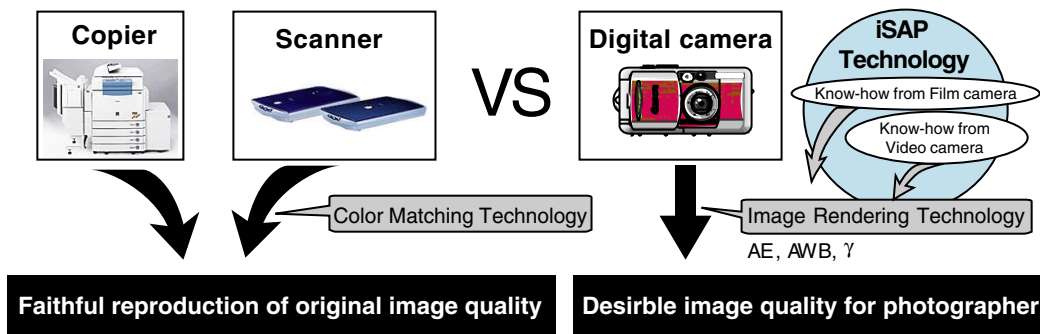

Fig.A-1 Comparison with image reproduction among copier,scanner and digital camera

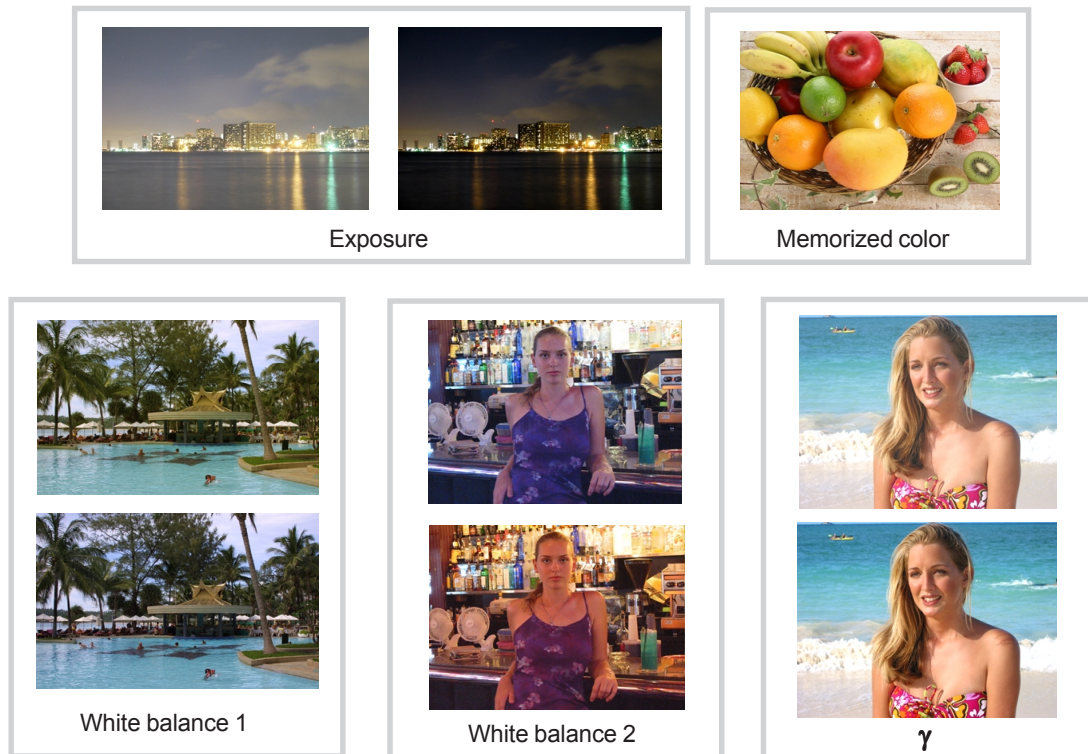

Photo A-1 Picture comparison among decisive factors for image

For more than 60 years since its inception, Canon has been asking ‘how can we take better pictures?’ As it has progressed, Canon has built up a tremendous database of know-how on photography as a result of its camera developments. From this photo data covering an enormous number of frames, Canon has classified statistically the frequency that users take certain photos and created a ‘Photographic Space’ (Figure A-2) that relates the ‘peripheral brightness’ and the ‘distance between camera and subject’ according to the focal length (zoom position) of the lens when taking a picture.

The PowerShot G3, the PowerShot S45 and the IXY DIGITAL 320 all come with functions that utilize this ‘Photographic Space’ data.

Specifically, as shown in Figure A-3, the distance between the camera and the subject is estimated from the focal length (zoom position) of the lens and the peripheral brightness when taking a photo.

Furthermore, by adding ‘photo parameters’ which is obtained with just before shooting, the scene that the user is about to photograph is pre-analyzed and precalculated. This method realizes faster and more precise AF, AE and AWB than ever before.

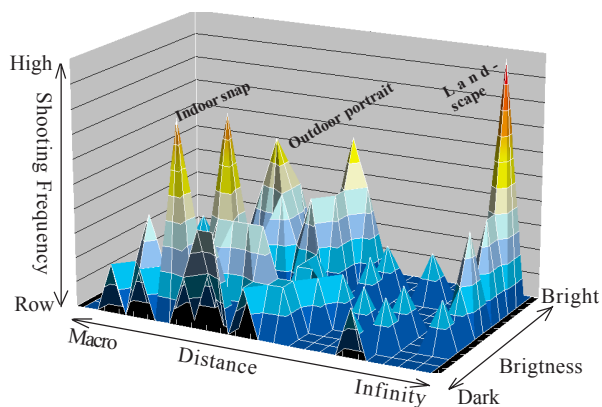

Fig.A-2 Distribution of object position at specific focal-length

- iSAPS High-speed AF

Using this iSAPS technology, the cameras achieve faster focusing speeds by optimizing the control of the AF scan range through a pre-analysis process to match the scene the user is about to take.

- iSAPS Intelligent AE/AWB

Using this iSAPS technology, the cameras achieve precise exposure and white balance through an algorithm optimized for the scene the user is about to take by analyzing the scene beforehand.

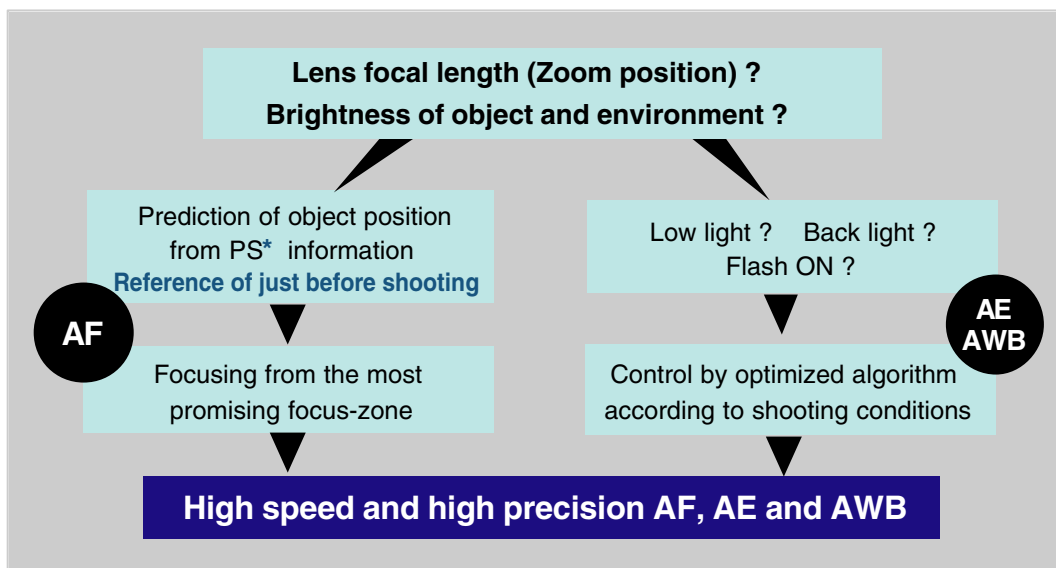

Fig. A-3 Flow of iSAPS technology

\* Shortend form of ‘Photographic Space’



# CHAPTER 2. TECHNICAL DESCRIPTION

## CONTENTS

1. Functions of each unit	
1.1 MAIN PCB ASS'Y -----	2-1
1.2 FLASH/DC UNIT -----	2-1
2. Outline of Circuits	
2.1 Power Supply Control -----	2-2
2.1.1 Power Supply Block Diagram -----	2-2
2.1.2 Power Control Sequence -----	2-2
2.2 Signal Processing -----	2-3
2.2.1 System Control -----	2-3
2.2.2 Picture Processing -----	2-4
2.2.3 Audio Processing (During record and playback) -----	2-4
3. Troubleshooting	
3.1 When an Error Code is Displayed -----	2-5
3.2 When a Problem Occurs -----	2-7



## 1. Functions of each unit

### 1.1 MAIN PCB ASS'Y

- 1) Driving the CCD Sensor.
- 2) Conversion of the image signal from the analog signal to the digital signal.
- 3) Controlling the power supply and the system by CPU. (Refer to Sections 2.1 and 2.2.)
- 4) Image processing, and reading and writing the image signal to and from the CF card using DSP. (Refer to Section 2.2.2.)
- 5) LCD drive and amplification of the video and audio output. (Refer to Section 2.2.3.)

### 1.2 FLASH/DC UNIT

- 1) Power supply drive (DC/DC converter).
- 2) Backlight for LCD drive.
- 3) Flash drive and charging circuit for the flash.

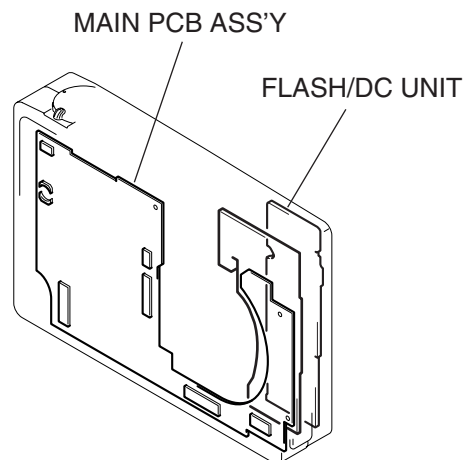

Fig. 1

## 2. Outline of Circuits

### 2.1 Power Supply Control

The power supply is controlled by the CPU mounted on the MAIN PCB ASS'Y.

#### 2.1.1 Power Supply Block Diagram

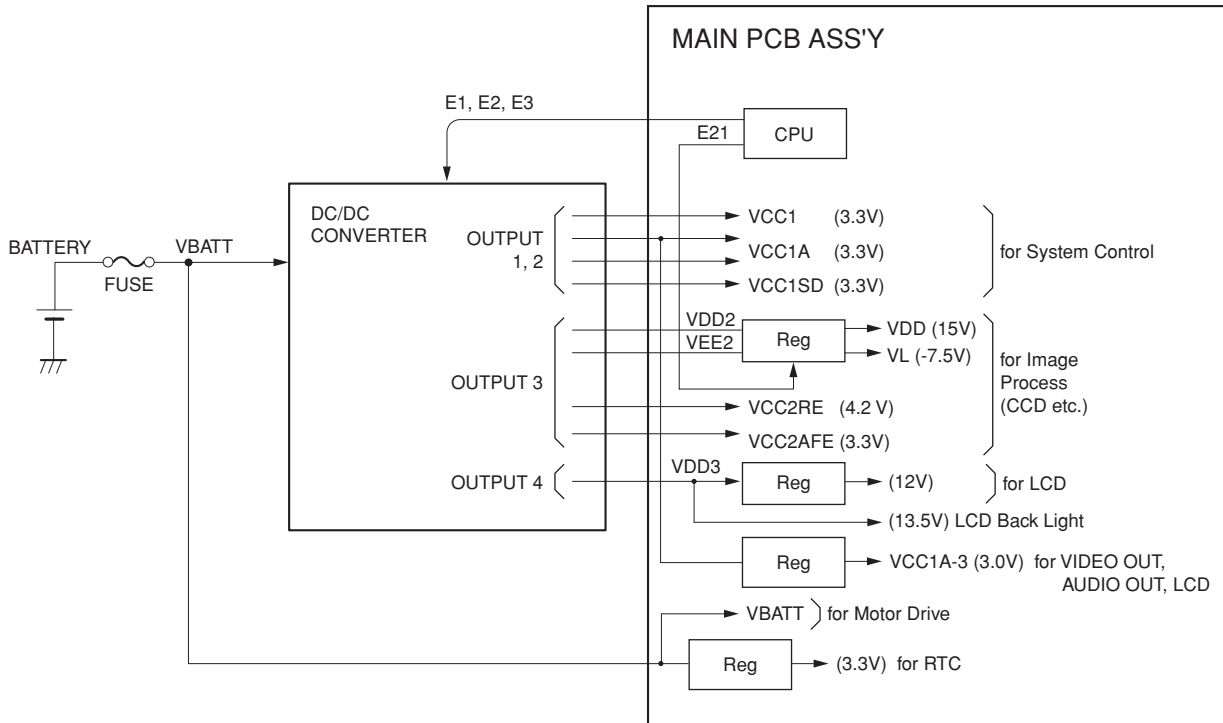
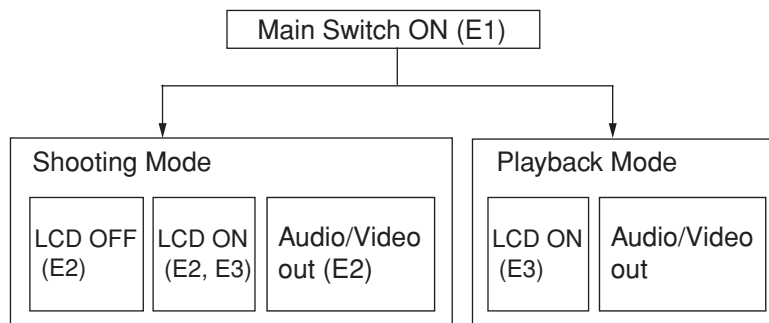

Fig. 2 Power System Block Diagram

#### 2.1.2 Power Control Sequence





## 2.2 Signal Processing

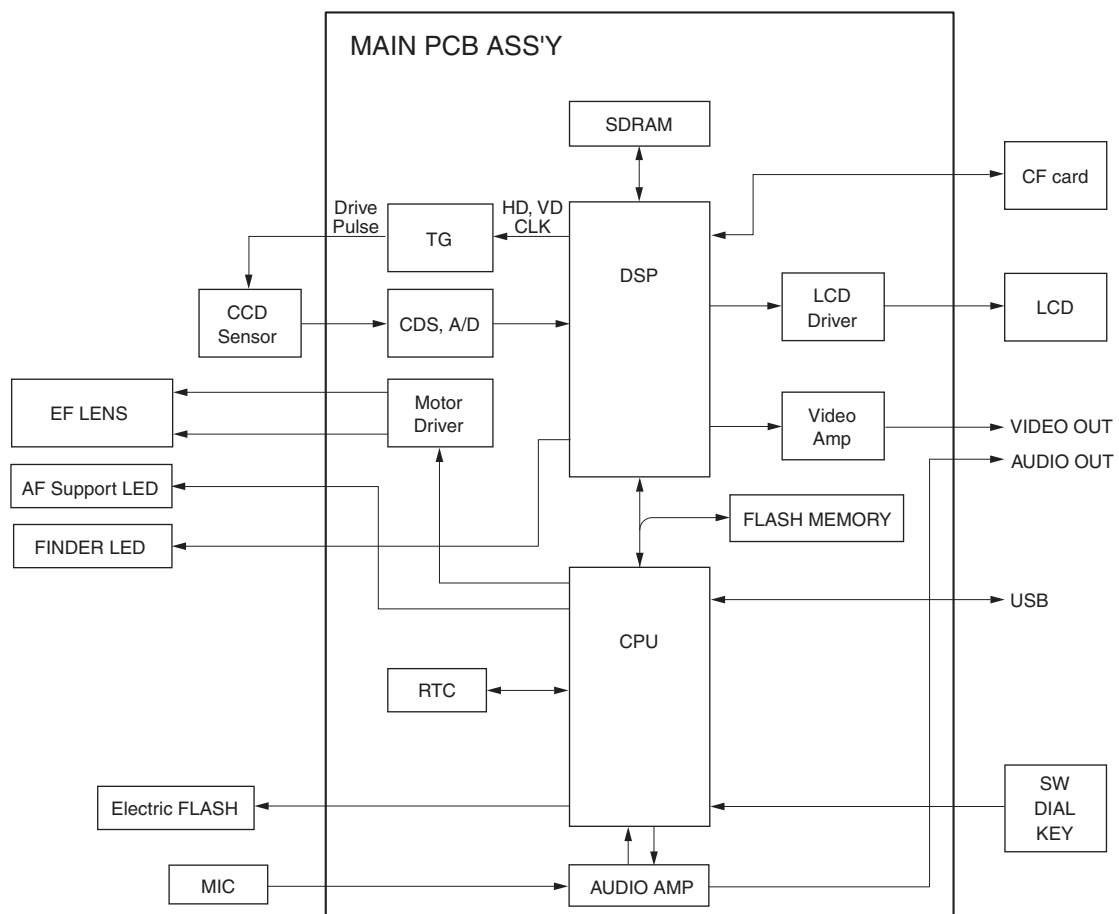

Fig. 3 Signal System Block Diagram

### 2.2.1 System Control

The CPU on the main PCB ass'y controls the EF lens (motor, shutter), operation switch receiver, USB communication and flowing circuits.

- TG: Creation of the CCD drive pulse
- CDS, A/D: CCD signal processing and conversion of the digital data
- LCD Driver: Driving the LCD
- FLASH MEMORY: Firmware memory
- DSP: Picture processing
- RTC: Clock count for watch
- AF Support LED: AF auxiliary, self-timer and red-eye protection also serves as a lamp
- Electric Flash: Flash and charging circuit

### 2.2.2 Picture Processing

- 1) The drive pulse of the CCD sensor is created by both clock from DSP and TG that is operated by sync. signal.  
The picture signal by the drive pulse is output from CCD sensor.  
The output signal of the CCD picture is converted to the signal processing and the digital data by the CDS and A/D converter, and is sent to the DSP.
- 2) The DSP circuit performs the following signal processing.
  - Processes the picture data (using the SDRAM).
  - Writes and reads the picture data to and from the CF card.
  - Outputs analog video signal to the LCD and VIDEO OUT.
- 3) The video signal that is supplied from the DSP is controlled by the LCD driver and is displayed on the LCD.
- 4) The video amplifier is activated when the video plug is inserted to the AV connector and drives the video signal in 75  $\Omega$ .

### 2.2.3 Audio Processing (During record and playback)

- 1) During animation recording.
  - The microphone audio signal is converted to the digital data by CPU and is recorded.
- 2) During playback, the data is converted back to the analog audio signal and is output to the AV connector.

## 3. Troubleshooting

### 3.1 When an Error Code is Displayed

[Remedy]

- Check for any abnormalities in the mounting of probable faulty parts or connector connections referring to the table below.
- Try replacing probable faulty parts referring to the below.

[NOTE]

- The error code is displayed on the LCD Monitor.
- Adjustments must be performed after the part has been replaced. For details, see the chapter of “Adjustments”.

Error Code	Name	Occurrence Conditions	Cause and Probable Faulty Part
E02	AF TIME OUT	AF processing did not end within the specified time.	MAIN PCB ASS'Y
		The focus lens was not driven.	MAIN PCB ASS'Y
E03	EF TIME OUT	Auto Flash Control did not end within the specified time.	MAIN PCB ASS'Y
E09	JPEG DMA TIME OUT	JPEG processing did not end within the specified time.	MAIN PCB ASS'Y
E14	UNKOWN	When unkown error, cause of which is not known, occurs.	UNKOWN
E16	IMAGING TIME OUT	When communication between CPU and peripheral IC is not completed within the specified time during recording using EVF or after completion of recording.	MAIN PCB ASS'Y
E18	ZOOM LENS ERROR	Movement of the lens barrel did not end within the specified time.	MAIN PCB ASS'Y
E23	CF NO SPACE	When the CF becomes full during writing of photographed images to CF, writing is repeatedly performed with the JPEG compression ratio successively increased to reduce the size of the image file until it can be successfully written to CF. This error occurs when writing of the JPEG image file fails after 10 retries at increasingly higher compression ratios.	MAIN PCB ASS'Y
E24	POWER ON ERROR	The power of the imaging circuit on the MAIN PCB ASS'Y was not detected.	MAIN PCB ASS'Y
E25	FOCUS PI ERROR	Detection of the focus PI (photo-interrupter) failed.	OPTICAL UNIT
			MAIN PCB ASS'Y
E26	CAPTURE TIME OUT	Writing of the photograph image to SDRAM did not end within the specified time.	MAIN PCB ASS'Y

CHAPTER 2. TECHNICAL DESCRIPTION

Error Code	Name	Occurrence Conditions	Cause and Probable Faulty Part
E27	CF WRITE TIME OVER	Free area could not be secured in the buffer for the photograph image within the specified time in the continuous shooting mode.	CF CARD
			MAIN PCB ASS'Y
E30	POWER OFF ERROR	The camera power was turned OFF while the image was being recorded to the CF Card. (The error code is displayed when the camera is next turned ON.) * This error may occur after E23.	The battery or DC plug was removed while the image was being recorded to the CF Card. → Remedy: Restart the camera.
E50	CF FORMAT ERROR	The CF Card could not be formatted properly.	CF CARD
E51	CF ACCESS ERROR	When image data cannot be read from CF normally.	CF CARD
E52	QUICK REVIEW ERROR	Review of the photograph image failed.	MAIN PCB ASS'Y

### 3.2 When a Problem Occurs

[Remedy]

- Check for any abnormalities in the mounting of probable faulty parts or connector connections referring to the table below.
- Try replacing probable faulty parts referring to the table below.

[NOTE]

- Adjustments must be performed after the part has been replaced. For details, see the chapter of “Adjustments”.

Problem (when an error code is not displayed)	Cause and Probable Faulty Part
The camera does not work.	MAIN PCB ASS'Y
	REAR COVER UNIT
	FLASH/DC UNIT
	BATTERY BOX UNIT
The image is not displayed on the LCD Monitor.	MAIN PCB ASS'Y
	BUTTON PCB ASS'Y
	LCD PANEL
	BACK LIGHT UNIT
The photograph image is abnormal.	OPTICAL UNIT
	MAIN PCB ASS'Y
The zoom does not function.	OPTICAL UNIT
	MAIN PCB ASS'Y
	BATTERY BOX UNIT
	REAR COVER UNIT
The Built-in Flash does not fire.	FLASH/DC UNIT
Video output is strange.	MAIN PCB ASS'Y
Communications with the personal computer is not possible.	MAIN PCB ASS'Y
The CF card or Micro Drives is not recognized.	CF CARD
	REAR COVER UNIT
	MAIN PCB ASS'Y
Buttons/The Mode dial do not work.	REAR COVER UNIT
	RLS PCB ASS'Y



# CHAPTER 3. REPAIR INSTRUCTION

## CONTENTS

1. Before Starting the Repair Work	3-1
1.1 Precaution on Flash High Tension Circuit	3-1
1.2 List of Supplies	3-1
1.3 Flexible Connectors	3-2
2. Disassembly/Assembly	3-3
2.1 Procedure	3-3
2.2 REAR COVER UNIT, CF COVER	3-4
2.3 FRONT COVER UNIT	3-5
2.4 SHUTTER BUTTON UNIT	3-6
2.5 SHIELD SHEET, MAIN PCB ASS'Y	3-7
2.6 LITHIUM BATTERY (2ND), MICROPHONE UNIT	3-8
2.7 BATTERY LOCK, BATTERY COVER	3-9
2.8 OPERATION KEY UNIT, TRIPOD SOCKET	3-10
2.9 LCD PANEL, BACK LIGHT UNIT	3-11
2.10 OPERATION PLATE, BATTERY BOX UNIT, CF UNIT	3-12
2.11 OPTICAL UNIT, FINDER UNIT	3-13
2.12 Assembling the FINDER UNIT	3-14
2.13 OPTICAL UNIT	3-15
2.14 FLASH/DC UNIT, FLASH UNIT, ELECT CAPACITOR	3-16
2.15 Screw List	3-17
3. Adjustments	3-18
3.1 Replacement Parts and Adjustment Items	3-18
3.2 Adjustment Tools	3-19
3.3 Before Starting Electrical Adjustments	3-20
3.3.1 TWAIN Driver Installation	3-20
3.3.2 Installing the Adjustment Software	3-20
3.3.3 Preparation	3-22
3.3.4 Starting up the Adjustment Software	3-23
3.3.5 Menu Window	3-23
3.3.6 How to Use the Adjustment Software	3-23
3.4 Calibration	3-24
3.4.1 Calibration	3-24
3.5 Adjustment Procedure	3-29
3.5.1 CCD Adjustment	3-29
3.5.2 Optical Unit Adjustment	3-31
3.5.3 Imaging Process Adjustment	3-33
3.5.4 Color Adjustment	3-36
3.5.5 Pixel Dot Adjustment	3-38
3.5.6 Flash Adjustment	3-40
3.5.7 Checking of sound recording/output	3-42





## 1. Before Starting the Repair Work

Be sure to read the following precaution before starting the repair work.

### 1.1 Precaution on Flash High Tension Circuit

- When the OPTICAL UNIT is removed, be sure to discharge the main capacitor.  
(Discharging resistor: 1 k ohms, approx. 5 W.)
- First contact the GND (–) terminal of the main capacitor with the discharging resistor. Then contact the positive (+) terminal of the main capacitor.

#### CAUTION:

Be careful of electric shock because the circuit is the high tension circuit.

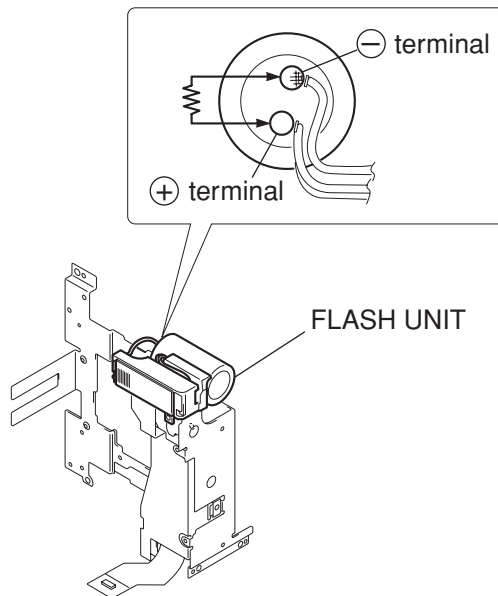

Fig. 3-1 Precaution on flash high tension circuit

### 1.2 List of Supplies

The following supplies are used for the re-assembling during service.

(1) List of supplies

New	Name of supplies	Part No.	Areas where supplies are used
	DIA BOND 1663G	CY9-8129-000	Attaching the parts together
	ADHESIVE TAPE, SONY T4000	CY4-6012-000	Fixing the flexible cable
	ADHESIVE TAPE, 3M NO.56	CY4-6018-000	BATTERY BOX UNIT
	HANARL (OIL)	DY9-3026-010	OPTICAL UNIT

### 1.3 Flexible Connectors

This product uses the four types of the flexible connectors.

① Type A

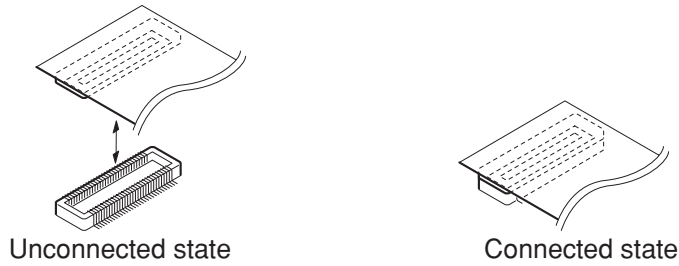

② Type B

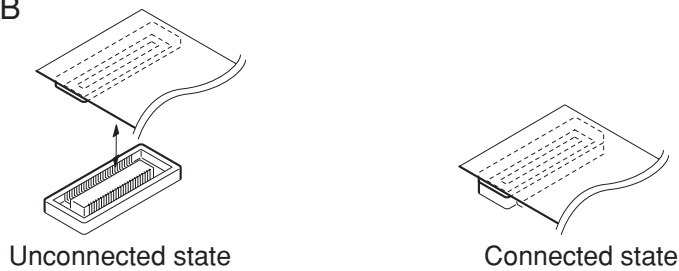

③ Type C

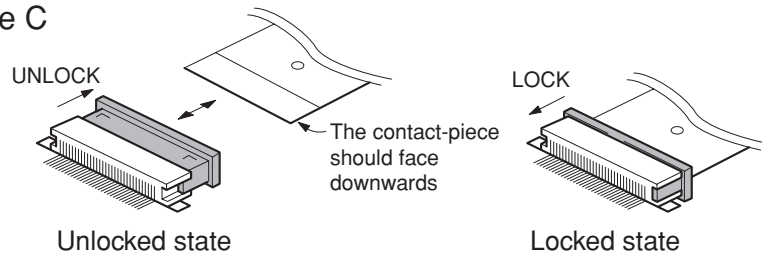

④ Type D

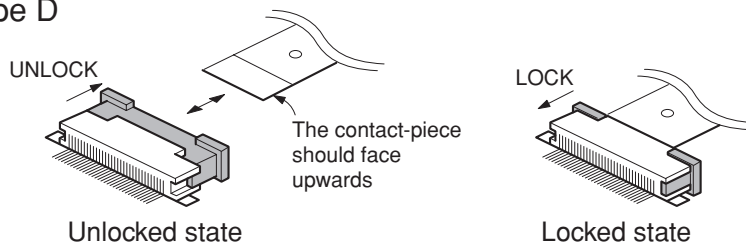

Fig. 3-2 Flexible connectors

**CAUTIONS:**

1. For the connectors of Type C and Type D, set them to the unlocked state before removing and inserting flexible card. After flexible card is inserted, set them to the locked state.
2. The flexible card is equipped with the holes as shown. Use them for removal and insertion by inserting the tweezers into them as required.

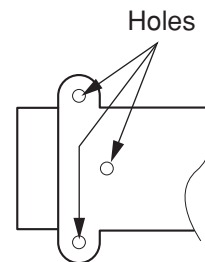
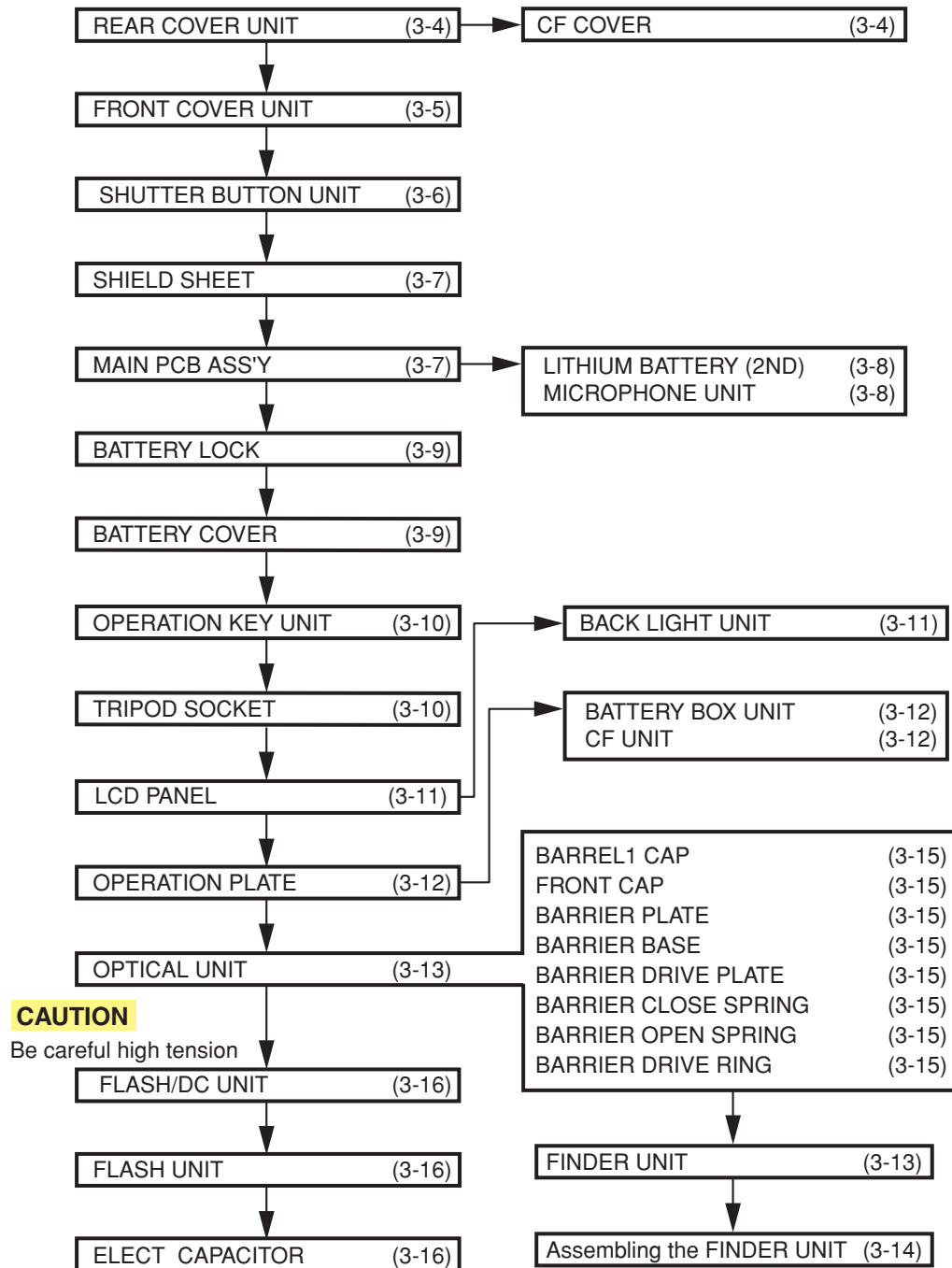

Fig. 3-3 Holes for removal

## 2. Disassembly/Assembly

### 2.1 Procedure

Disassembling procedure of PowerShot S230 and DIGITAL IXUS v<sup>3</sup> is shown by the following flowchart. Reverse the disassembling procedure to reassemble them. \* The pages to refer are shown in parenthesis ( ).



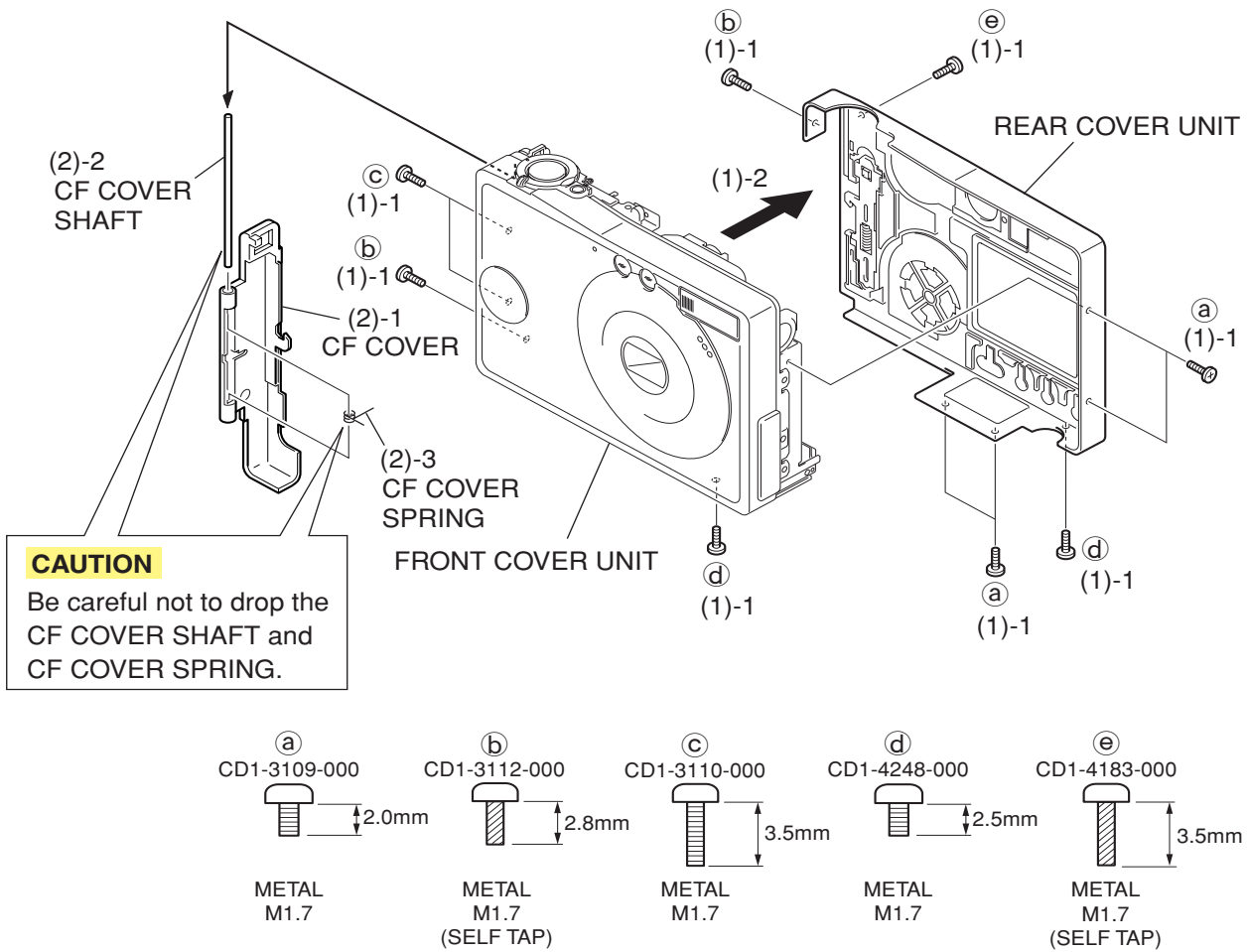

Fig. 3-4 REAR COVER UNIT, CF COVER

## 2.2 REAR COVER UNIT, CF COVER

### (1) REAR COVER UNIT

1. Remove the four screws of (a) and the two screws of (b) and the two screws of (c) and the two screws of (d) and the screw of (e).
2. Remove the REAR COVER UNIT in the direction of arrow.

### (2) CF COVER

1. Remove the CF COVER.
2. Remove the CF COVER SHAFT.
3. Remove the CF COVER SPRING.

### **CAUTION**

Be careful not to drop the CF COVER SHAFT and CF COVER SPRING.

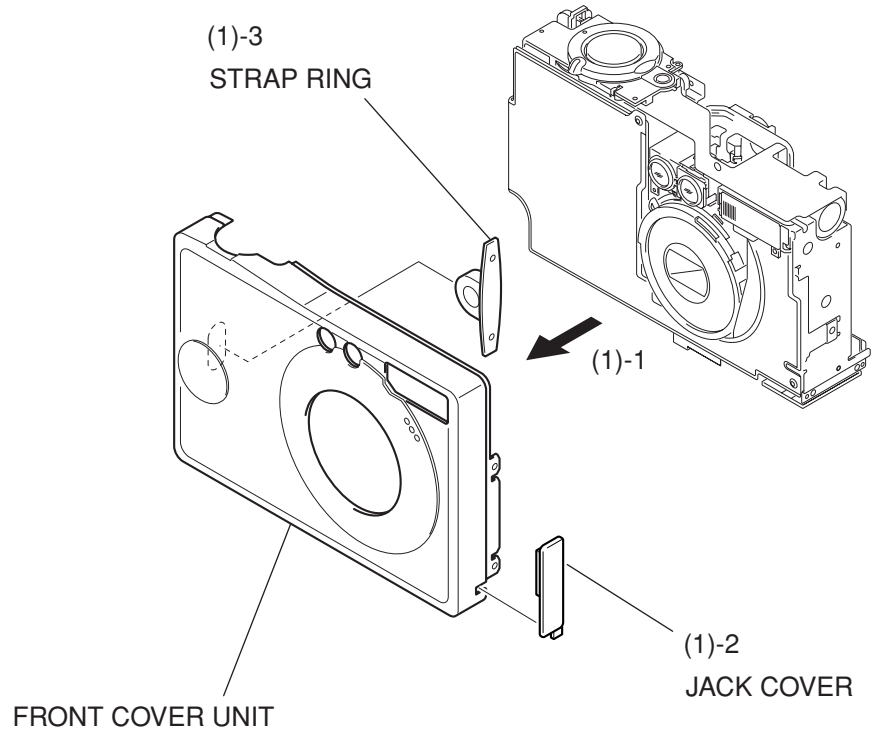

Fig. 3-5 FRONT COVER UNIT

## 2.3 FRONT COVER UNIT

### (1) FRONT COVER UNIT

1. Remove the FRONT COVER UNIT in the direction of arrow.
2. Remove the JACK COVER.
3. Remove the STRAP RING.

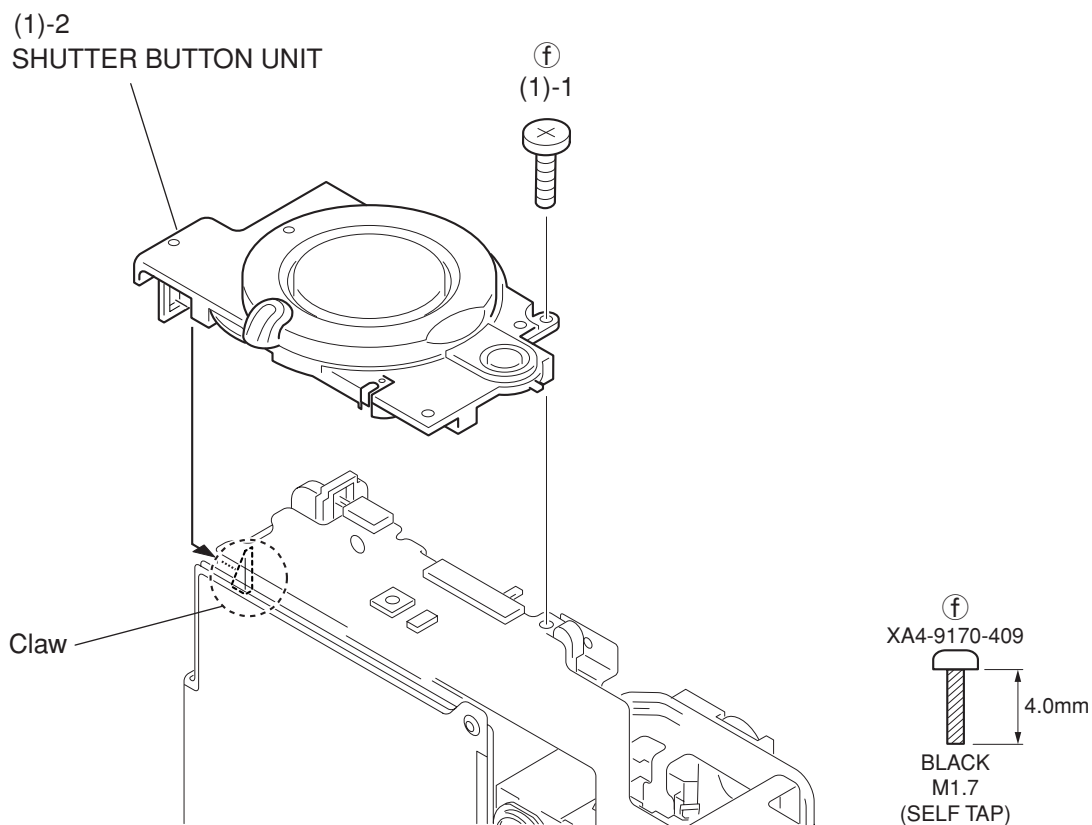

Fig. 3-6 SHUTTER BUTTON UNIT

## 2.4 SHUTTER BUTTON UNIT

### (1) SHUTTER BUTTON UNIT

1. Remove the screw of (f).
2. While taking care of the claw remove the SHUTTER BUTTON UNIT.

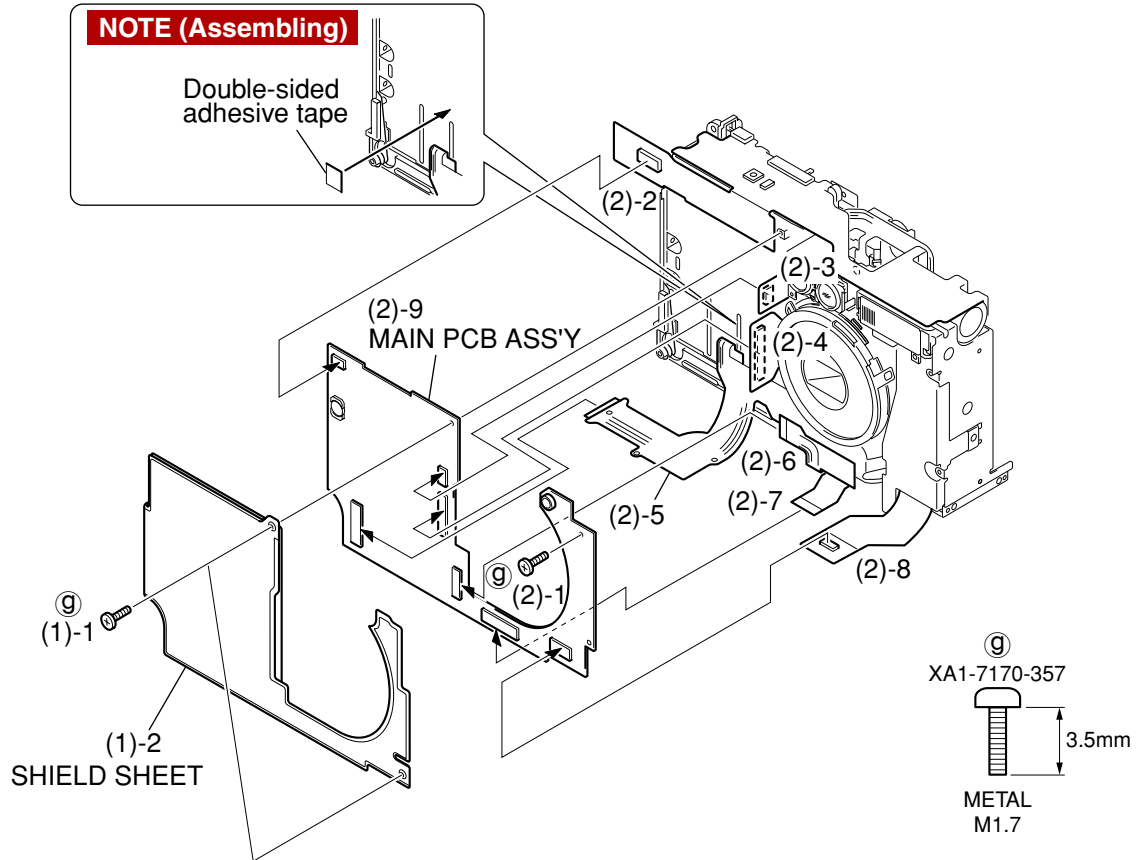

Fig. 3-7 SHIELD SHEET, MAIN PCB ASS'Y

## 2.5 SHIELD SHEET, MAIN PCB ASS'Y

### (1) SHIELD SHEET

1. Remove the two screws of ⑨.
2. Remove the SHIELD SHEET.

### (2) MAIN PCB ASS'Y

1. Remove the screw of ⑨.
2. Remove the Connector of the BATTERY BOX UNIT.
3. Remove the Connector of the OPTICAL UNIT.
4. Remove the Connector of the CF UNIT.
5. Remove the flexible printed wired board of the OPTICAL UNIT.
6. Remove the flexible printed wired board of the OPERATION KEY UNIT.
7. Remove the flexible printed wired board of the LCD.
8. Remove the Connector of the FLASH/DC UNIT.
9. Remove the MAIN PCB ASS'Y.

**NOTE (Assembling)** Attach the Double-sided adhesive tape to the BATTERY BOX UNIT.

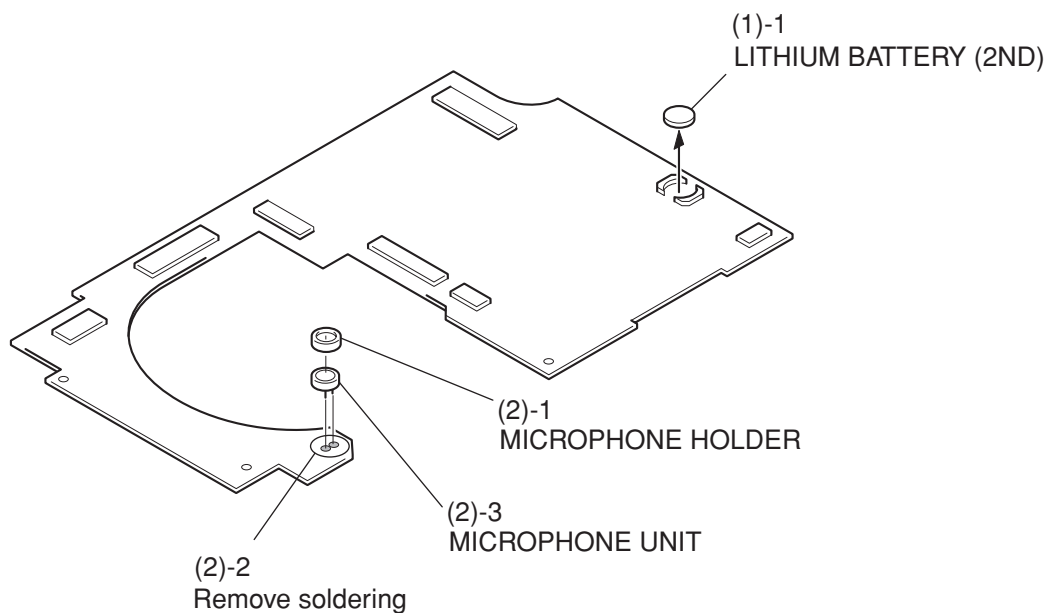

Fig. 3-8 LITHIUM BATTERY (2ND), MICROPHONE UNIT

## 2.6 LITHIUM BATTERY (2ND), MICROPHONE UNIT

### (1) LITHIUM BATTERY (2ND)

1. Remove the LITHIUM BATTERY. (2ND)

### (2) MICROPHONE UNIT

1. Remove the MICROPHONE HOLDER.
2. Remove soldering. (Two places)
3. Remove the MICROPHONE UNIT.



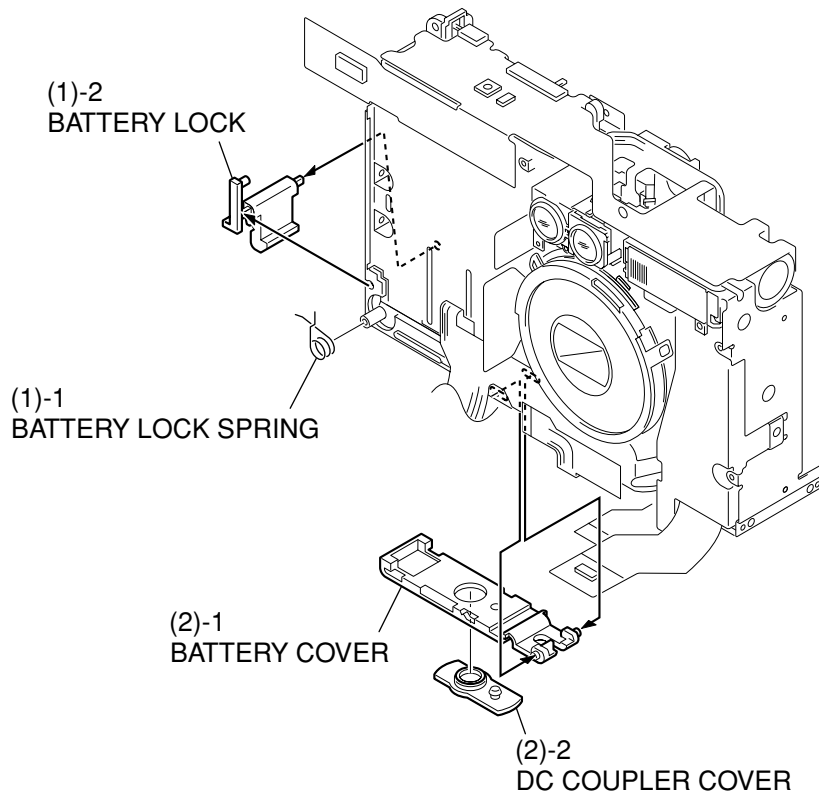

Fig. 3-9 BATTERY LOCK, BATTERY COVER

## 2.7 BATTERY LOCK, BATTERY COVER

### (1) BATTERY LOCK

1. Remove the BATTERY LOCK SPRING.
2. Remove the BATTERY LOCK.

### (2) BATTERY COVER

1. Remove the BATTERY COVER.
2. Remove the DC COUPLER COVER.

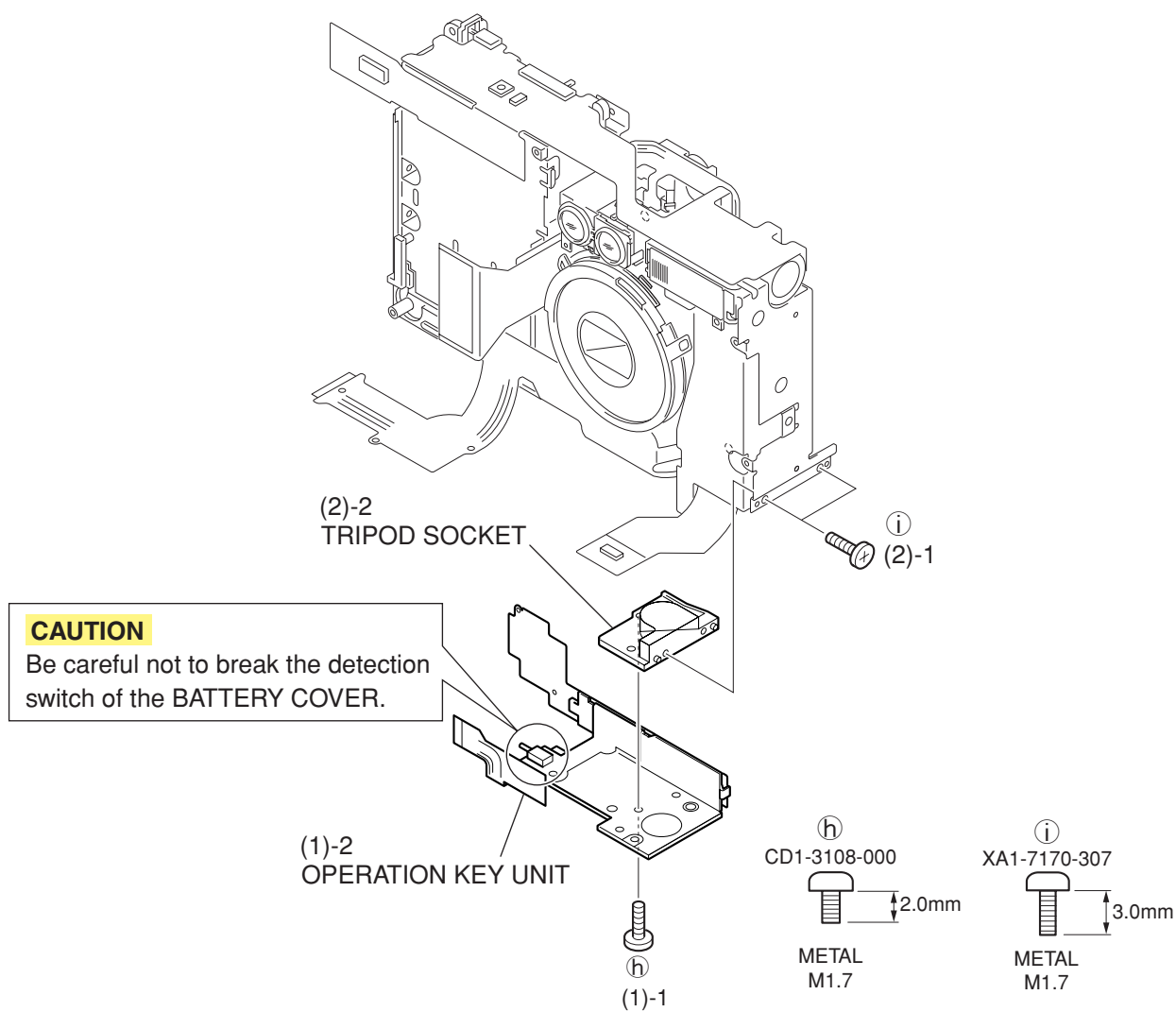

Fig. 3-10 OPERATION KEY UNIT, TRIPOD SOCKET

## 2.8 OPERATION KEY UNIT, TRIPOD SOCKET

### (1) OPERATION KEY UNIT

1. Remove the screw of (h).
2. Remove the OPERATION KEY UNIT.

### **CAUTION**

Be careful not to break the detection switch of the BATTERY COVER.

### (2) TRIPOD SOCKET

1. Remove the two screws of (i).
2. Remove the TRIPOD SOCKET

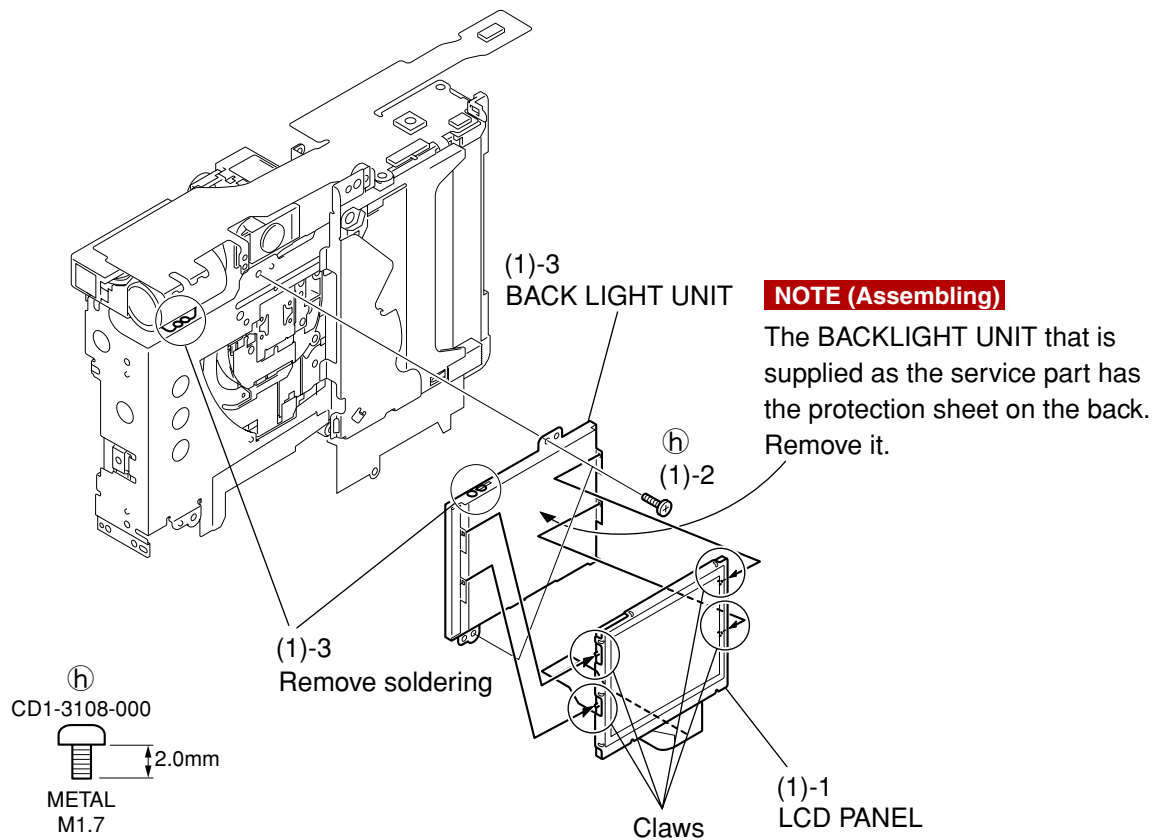

Fig. 3-11 LCD PANEL, BACKLIGHT UNIT

## 2.9 LCD PANEL, BACK LIGHT UNIT

### (1) LCD PANEL, BACK LIGHT UNIT

1. While taking care of the claws remove the LCD PANEL.
2. Remove the two screws of (h).
3. Remove soldering (Two places) and remove the BACK LIGHT UNIT.

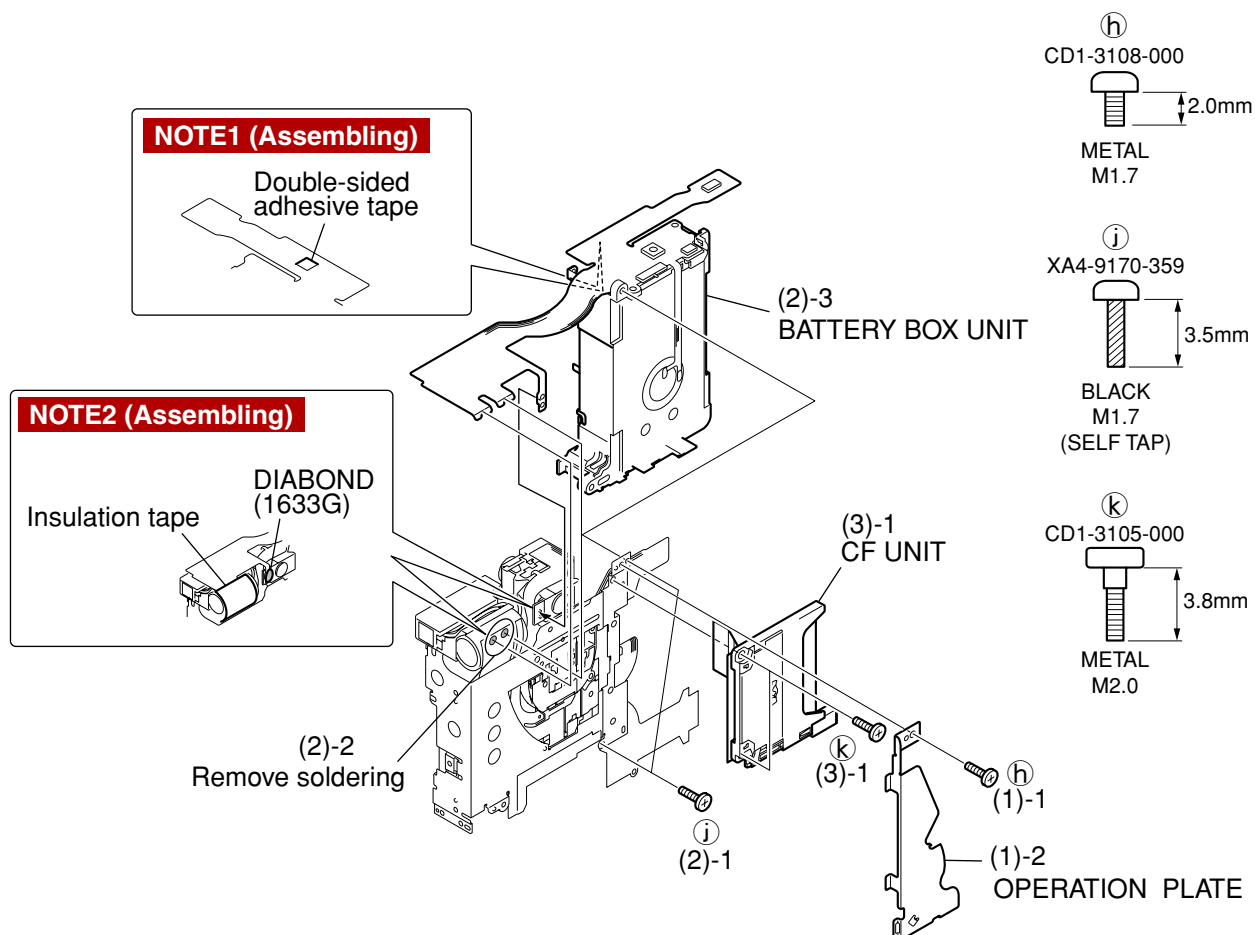

Fig. 3-12 OPERATION PLATE, BATTERY BOX UNIT, CF UNIT

## 2.10 OPERATION PLATE, BATTERY BOX UNIT, CF UNIT

### (1) OPERATION PLATE

1. Remove the screw of (h).
2. Remove the OPERATION PLATE.

### (2) BATTERY BOX UNIT

1. Remove the two screws of (j).
2. Remove soldering. (Two places)
3. Remove the BATTERY BOX UNIT.

**NOTE1 (Assembling)** Attach the Double-sided adhesive tape to the BATTERY BOX UNIT flexible.

**NOTE2 (Assembling)** Attach the DIABOND and Double-sided adhesive tape to the BATTERY BOX UNIT flexible.

### (3) CF UNIT

1. Remove the two screws of (k).
2. Remove the CF UNIT.

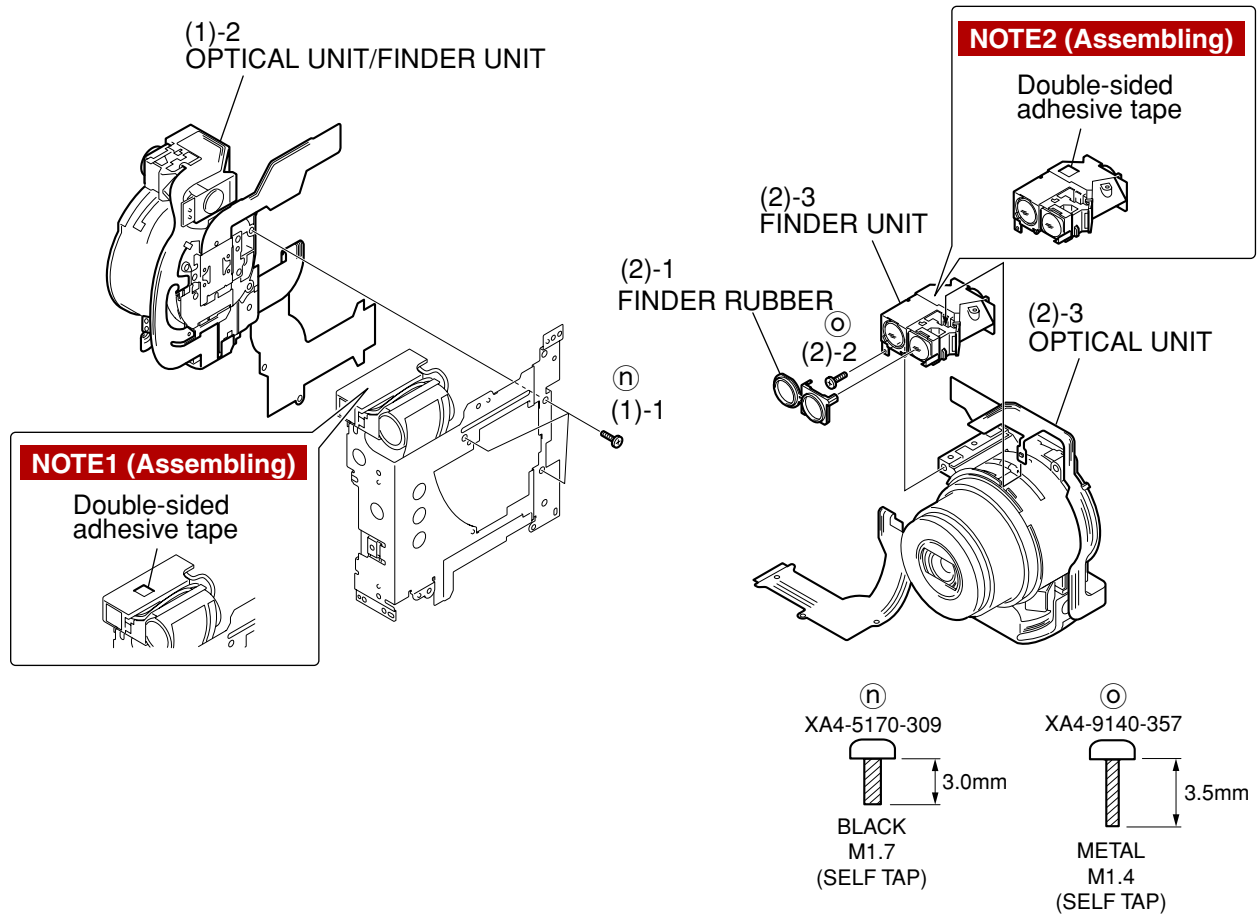

Fig. 3-13 OPTICAL UNIT, FINDER UNIT

## 2.11 OPTICAL UNIT, FINDER UNIT

### (1) OPTICAL UNIT

1. Remove the three screws of (n).
2. Remove the OPTICAL UNIT/FINDER UNIT.

**NOTE1 (Assembling)** Attach the Double-sided adhesive tape to the FLASH UNIT.

### (2) FINDER UNIT

1. Remove the FINDER RUBBER.
2. Remove the screw of (o).
3. Remove the OPTICAL UNIT and FINDER UNIT.

**NOTE2 (Assembling)** Attach the Double-sided adhesive tape to the FINDER UNIT.

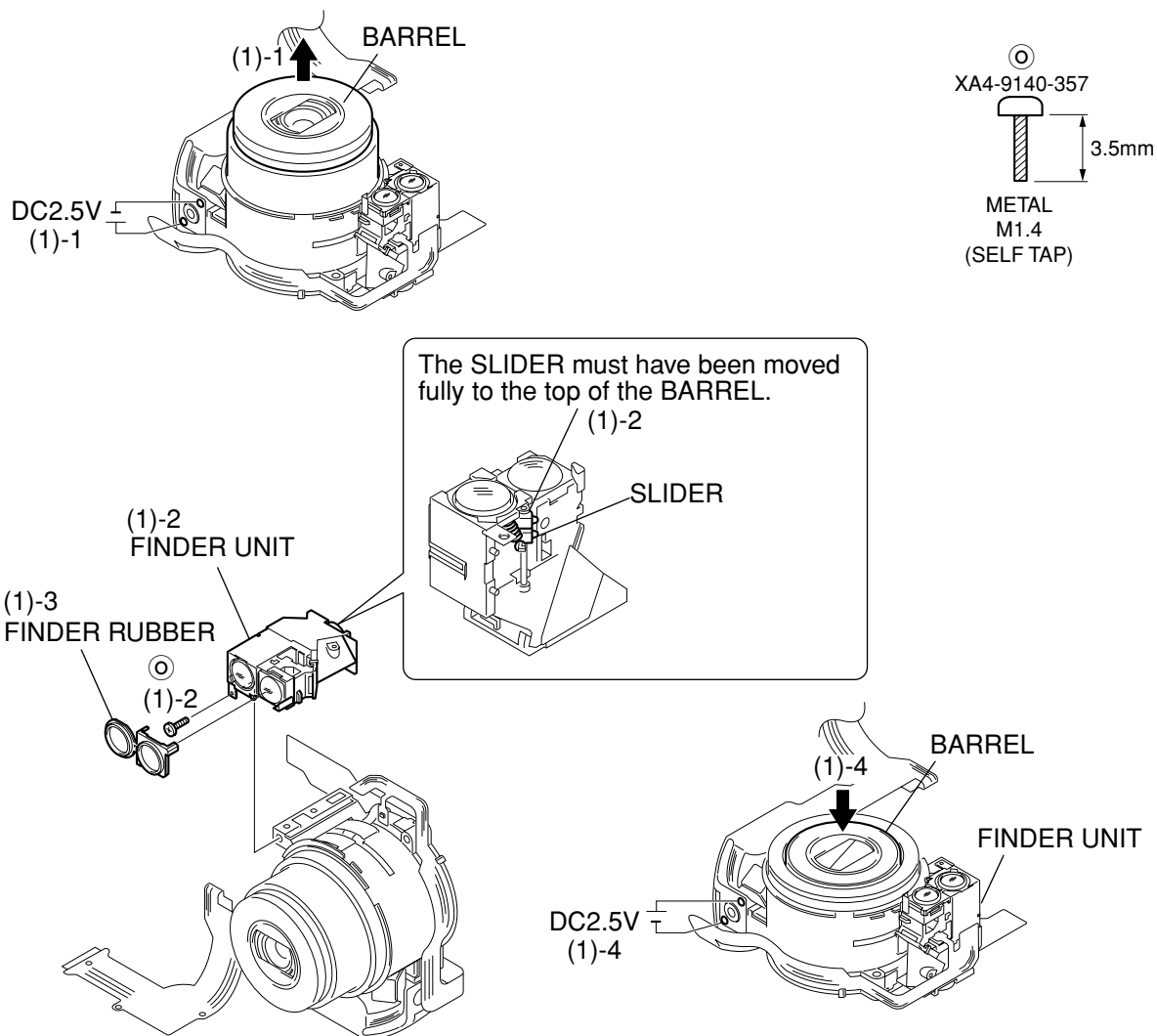

Fig. 3-14 Assembling the FINDER UNIT

## 2.12 Assembling the FINDER UNIT

### (1) Assembling the FINDER UNIT

1. Apply the voltage (DC 2.5V) across the motor terminal to drive the motor until the motor stops and the BARREL fully comes out.
2. Move the SLIDER fully to the top of the BARREL and secure it with the screw of ①.
3. Assembling the FINDER RUBBER to FINDER UNIT.
4. Apply the voltage (DC 2.5V) across the motor terminal to drive the motor until the motor stops and the BARREL is full housed.

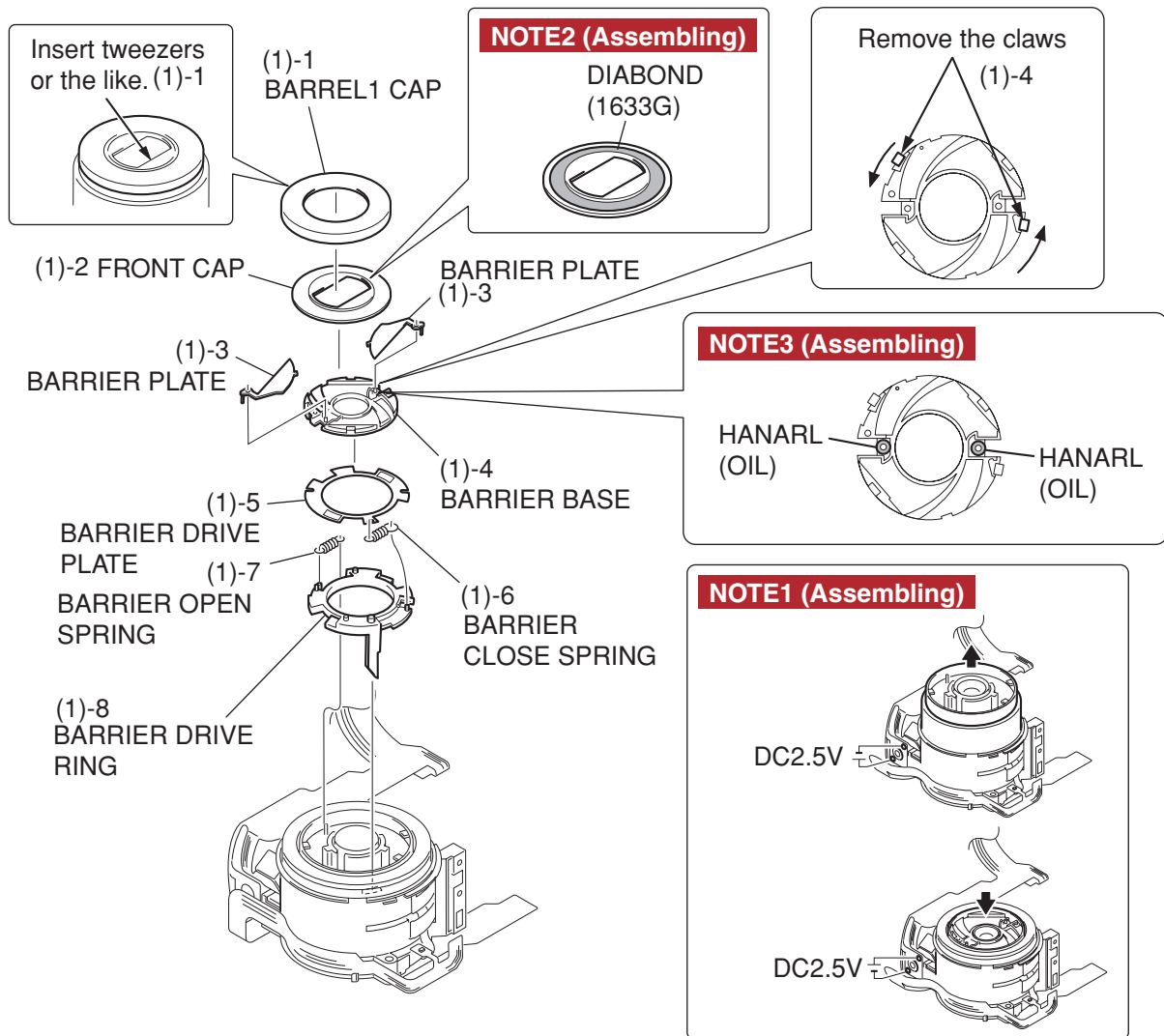

Fig. 3-15 OPTICAL UNIT

## 2.13 OPTICAL UNIT

### (1) OPTICAL UNIT

1. Remove the BARREL1 CAP by inserting tweezers or the like into its groove.
2. Remove the FRONT CAP.
3. Remove the BARRIER PLATE (2 pieces).
4. Remove the two claws and remove the BARRIER BASE.
5. Remove the BARRIER DRIVE PLATE.
6. Remove the BARRIER CLOSE SPRING.
7. Remove the BARRIER OPEN SPRING.
8. Remove the BARRIER DRIVE RING.

**NOTE1 (Assembling)** Apply the voltage (DC 2.5V) across the motor terminal to drive the motor until the motor stops and the BARREL is full housed.

**NOTE2 (Assembling)** Attach the DIABOND to the FRONT CAP.

**NOTE3 (Assembling)** Attach the HANARL to the BARRIER BASE.

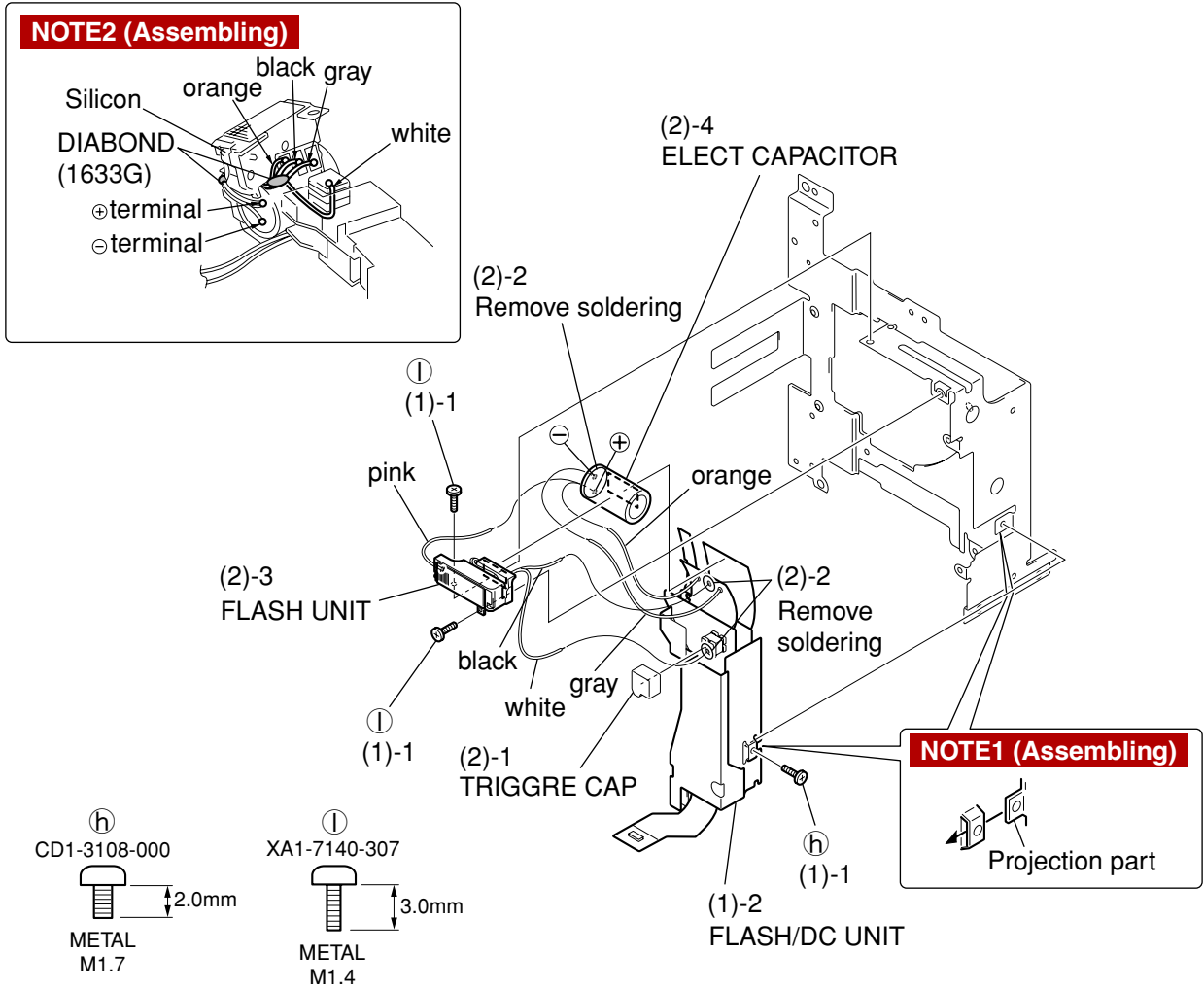

Fig. 3-16 FLASH/DC UNIT, FLASH UNIT, ELECT CAPACITOR

## 2.14 FLASH/DC UNIT, FLASH UNIT, ELECT CAPACITOR

### (1) FLASH/DC UNIT

1. Remove the screw of (h) and two screws of (1).
2. Remove the FLASH/DC UNIT.

**NOTE1 (Assembling)** Please insert the projection of MAIN FRAME in the slot of FLASH/DC UNIT.

### (2) FLASH UNIT, ELECT CAPACITOR

1. Remove the TRIGGER CAP
2. Remove soldering. (white, black, gray, orange, pink )
3. Remove the FLASH UNIT.
4. Remove the ELECT CAPACITOR.

**NOTE2 (Assembling)** Attach the DIABOND.



2.15 Screw List

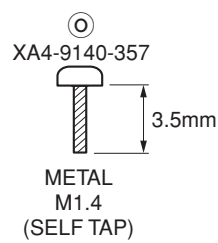
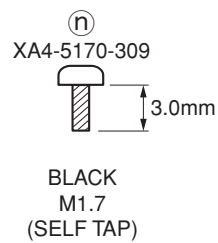
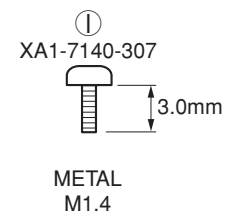
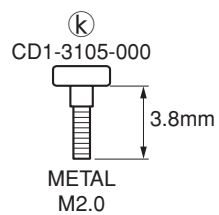
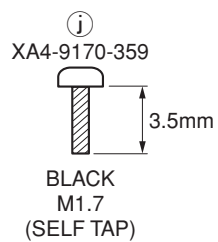
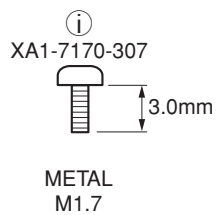
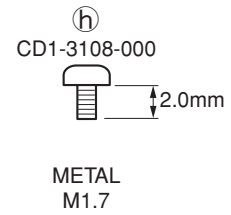
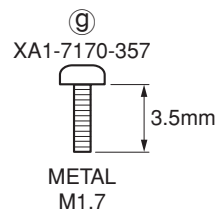
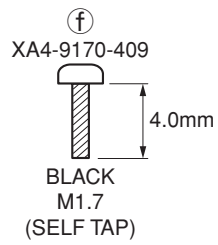
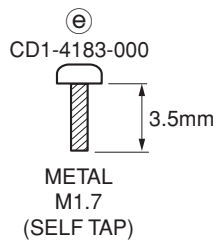
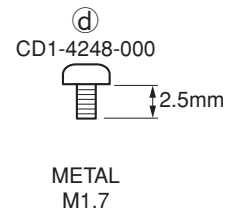
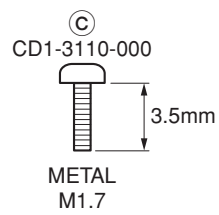
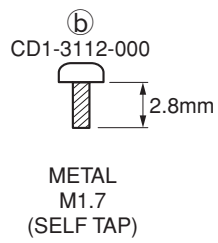
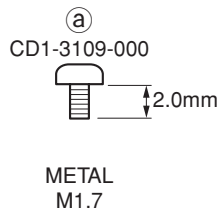

## 3. Adjustments

### 3.1 Replacement Parts and Adjustment Items

PowerShot S230/DIGITAL IXUS v<sup>3</sup> requires electrical adjustments when certain parts are replaced. The table below indicates the adjustments required for the respective part replacements. For all other parts not listed below, no electrical adjustments are necessary after replacement.

Adjustment Items Replacement Part	CCD Adjustment	Optical Unit Adjustment	Imaging Process Adjustment	Color Adjustment	Pixel Dot Adjustment	Flash Adjustment
BATTERY BOX UNIT						
DC/DC CONV. UNIT						
OPTICAL UNIT	● #1	● #2	● #3	● #4	● #5	● #6
FLASH UNIT						●
MAIN PCB ASS'Y	○	○	○	○	○	○
LCD PANEL						
BACK LIGHT UNIT						

● : Adjustment is necessary after replacement.

○ : Adjustment is necessary after replacement.

(Adjustment is not necessary, only if the adjustment data has been saved and then transferred after the part is replaced.)

Blank : Adjustment is unnecessary.

\* When OPTICAL UNIT is replaced, adjust certainly at the procedure as below.

#1. CCD Adjustment

#2. Optical Unit Adjustment

#3. Imaging Process Adjustment

#4. Color Adjustment

#5. Pixel Dot Adjustment

#6. Flash Adjustment

## 3.2 Adjustment Tools

The following tools are required for electrical adjustment.

DESCRIPTION	PARTS NO.	REMARKS
PC/AT-Compatible Machine (Windows98 or 2000 pre-installed Model, USB port)	—	Local purchase
Adjustment Software (CD-ROM)	CY8-4380-031	CD-ROM, SERVICE MANUAL (J/E)
Compact Power Adapter CA-PS500	—	Enclosed in “AC Adapter Kit ACK500”
AC Cable	—	Enclosed in “AC Adapter Kit ACK500”
DC Coupler DR-500	—	Enclosed in “AC Adapter Kit ACK500”
INTERFACE CABLE IFC-200PCU	—	(or Local purchase)
Brightness Box (light source A)	—	Local purchase
Color Viewer (5600° K)	DY9-2039-100	(or Local purchase)
Color Bar Chart	DY9-2002-000	(or Local purchase)
18% Gray Chart	CY4-6016-000	
Zoom/AF Chart	—	*1
W-10 Filter *2	CY9-1543-000	(or Local purchase)
C-12 Filter	DY9-2029-000	(or Local purchase)
FL-W Filter	CY9-1550-000	(or Local purchase)
ND-2 Filter	—	Local purchase
ND-4 Filter	—	Local purchase
ND-8 Filter	—	Local purchase
Light-Shielding Cloth (500 × 500 or larger)	—	Local purchase
Tripod	—	Local purchase
Reference Camera	—	Merchandise
DIGITAL CAMERA SolutionDisk Ver.11	—	Enclosed in Merchandise

\*1 Print the Zoom/AF Chart on the legal size paper from the “Zoom\_AFChart\_Legal.pdf” ( in the folder of this CD-ROM, :\\Adjust\\Chart).  
Print the Auto Focus Chart on the A3 size paper from the “Zoom\_AFChart\_A3.pdf”.

\*2 2pcs. required.

### 3.3 Before Starting Electrical Adjustments

#### 3.3.1 TWAIN Driver Installation

Install the USB Driver for Adjustment in the CD-ROM to PC.  
(“This Adjustment Software” is impossible when the RS-232C TWAIN driver is used.)

#### 3.3.2 Installing the Adjustment Software

1. Double click the icon on the launcher screen or a file in the CD-ROM. (Model name of the camera that you are going to adjust and the name of the adjustment software are different.)

Model	Icon	File Path
PowerShot S230/DIGITAL IXUS V <sup>3</sup>	S230 V <sup>3</sup> _ENG_Adj.	\Adjust\ENG\Setup.exe

2. When the dialog box below appears, click the “OK” button.

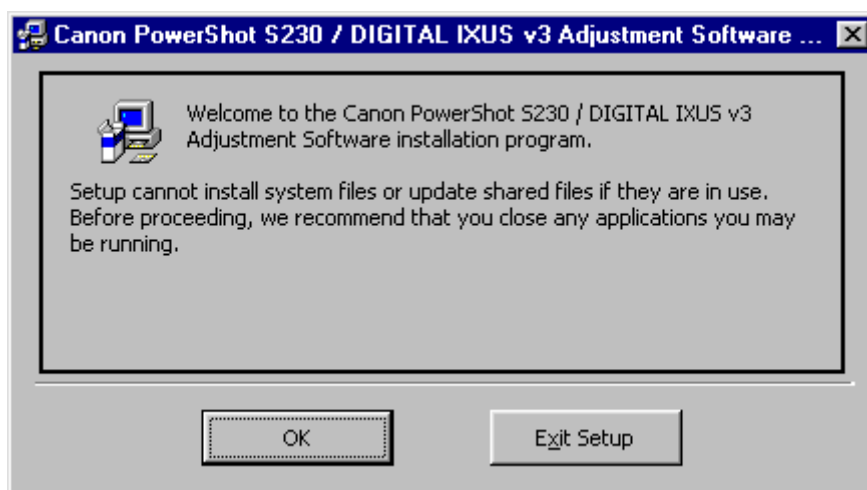

3. When the dialog box below appears, click the  button. (Software installation will then begin.)

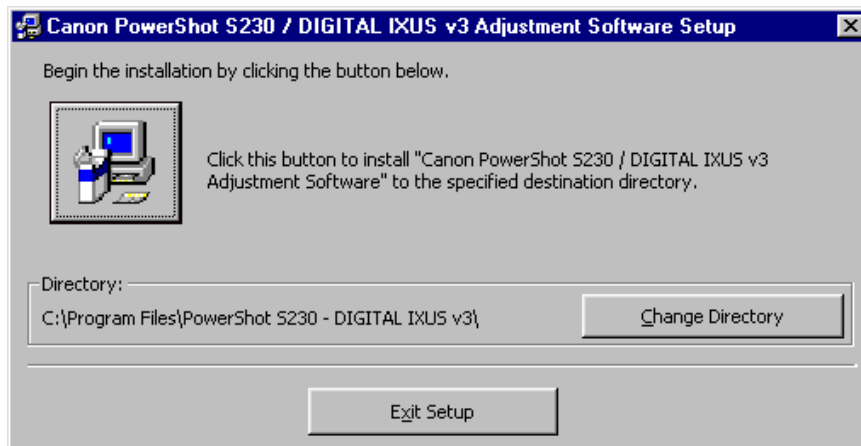

4. When the dialog box below appears, click the "Continue" button.  
(In the case that you do not add a shortcut on desktop, remove clicking from the check box.)

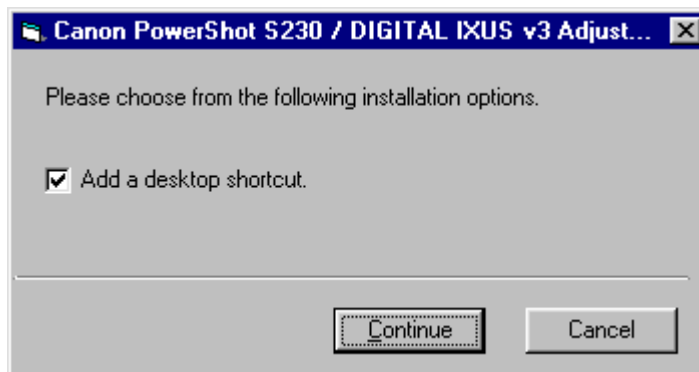

### 3.3.3 Preparation

Before starting up the Adjustment Software, follow the preparatory steps below:

1. Obtain all the tools necessary for the adjustment.
2. For the Optical Unit Adjustment, jot down the data written on the Optical Unit. You will need it later.

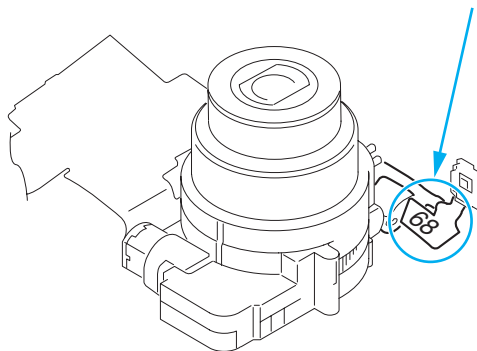

3. Connect the Camera to the Power Source with the Compact Power Adapter CA-PS500, AC Cable & DC Coupler DR-500.
4. Set the Replay Mode on the camera and turn on.
5. Set the Communication Mode to Normal.

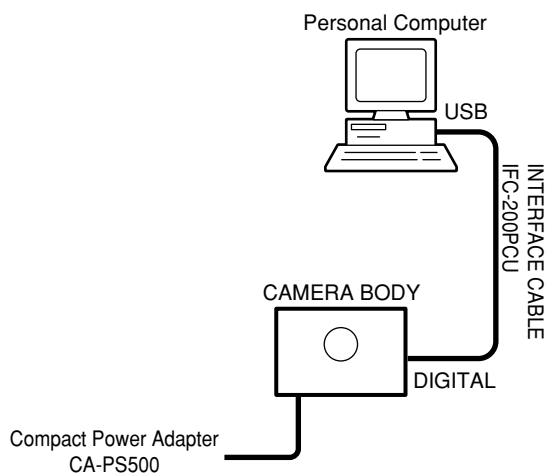

6. Connect the Camera's Digital terminal to the PC's USB Port with INTERFACE CABLE IFC-200 PCU.
7. Turn on the camera.  
**Note:** Perform the preparation in the following order otherwise the camera won't work properly.

### 3.3.4 Starting up the Adjustment Software

After completing the preparatory steps, click Start and move the cursor to Program; then select Canon Digital Camera and click PowerShot S230/DIGITAL IXUS V<sup>3</sup> Adjustment.

### 3.3.5 Menu Window

When the Adjustment Software starts up, the Menu Window below will appear.

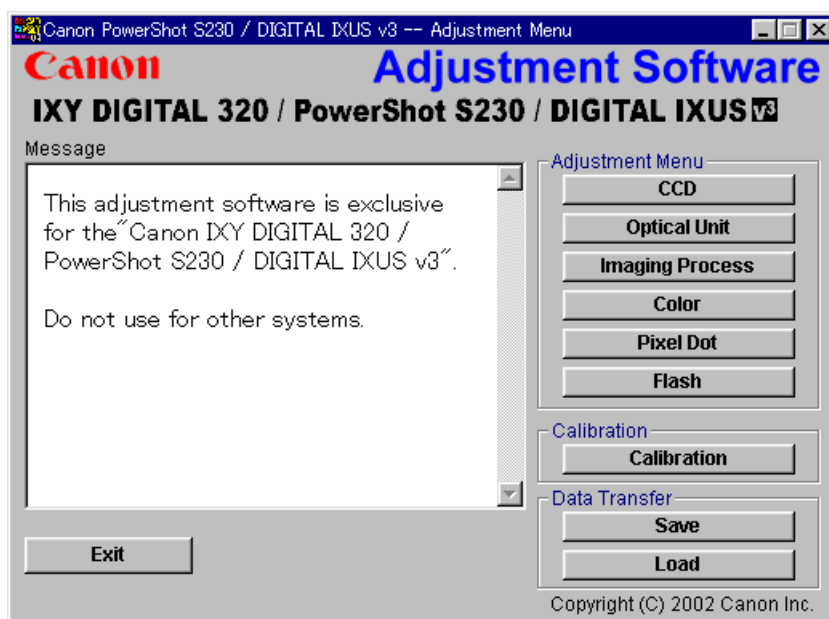

### 3.3.6 How to Use the Adjustment Software

#### Calibration/Adjustment

For starting, click the button related with adjustment.

- \* Whenever you use your light source for the adjustment for the first time, be sure to click the “Calibration” Button.

#### Quitting the Adjustment Software

Click the “Exit” button.

#### Saving or Loading data

- “Save” button : This button saves all adjustment data stored on the camera in text format.
- “Load” button : This button loads all adjustment data saved in text format to the camera.

#### Saving or Loading data

- “Save” button : This button saves all adjustment data stored on the camera in text format.
- “Load” button : This button loads all adjustment data saved in text format to the camera.

#### Notes



- If the adjustment fails, a message indicating the failure will appear on each product. If this happens, do the adjustment again.
- The Adjustment Software is dedicated only to Canon Digital Camera PowerShot S45. Never use it for any other camera.
- The Windows98 or 2000 must be pre-installed on the computer that is equipped with the USB terminal. (Windows95 does not support the USB.)
  - \* The operation with the Windows XP, etc. is not guaranteed.

### 3.4 Calibration

#### 3.4.1 Calibration

■ Tools Used

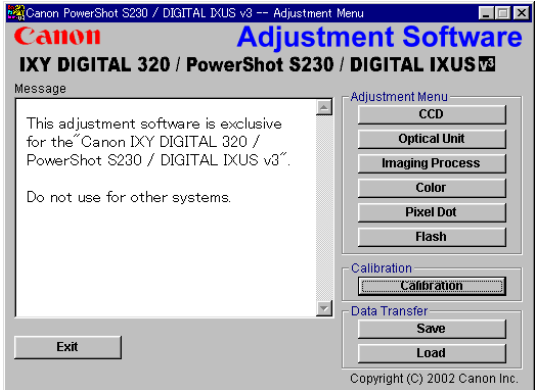
- Personal Computer
- Adjustment Software
- Compact Power Adapter CA-PS500
- AC Cable
- DC Coupler DR-500
- INTERFACE CABLE IFC-200PCU
- Brightness Box (light source A)
- Color Viewer (5600° K)
- Color Bar Chart
- W-10 Filter (2pcs.)
- C-12 Filter
- FL-W Filter
- ND-2 Filter
- ND-4 Filter
- ND-8 Filter
- Reference Camera (Merchandise)

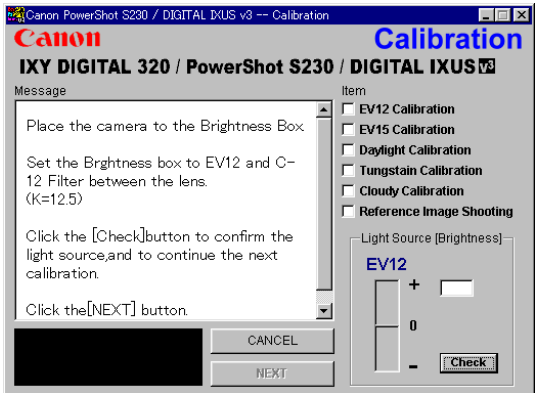
<p>1</p>	<p>Click the “Calibration” button.</p>	
<p>2</p>	<ol style="list-style-type: none"> <li>1. When the message on the right appears, check that the reference camera (Merchandise) is connected to the computer.</li> <li>2. Click the “OK” button.</li> </ol>	
<p>3</p>	<p>When the message on the right appears, go to 4.</p>	

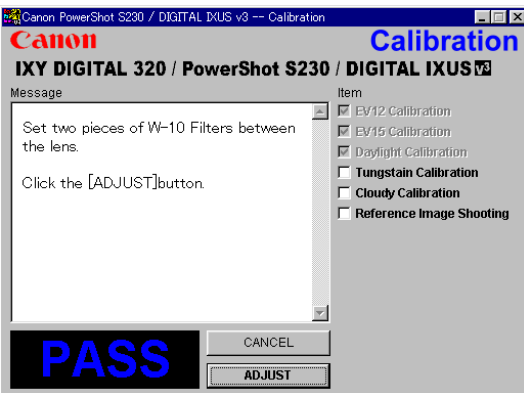
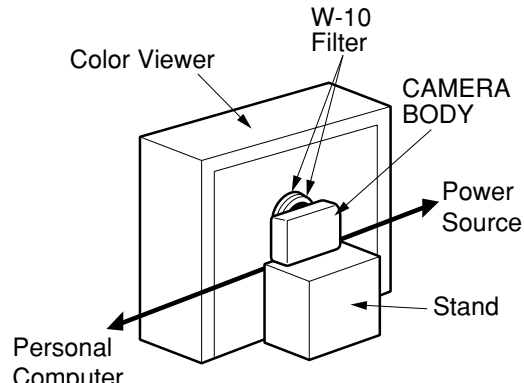
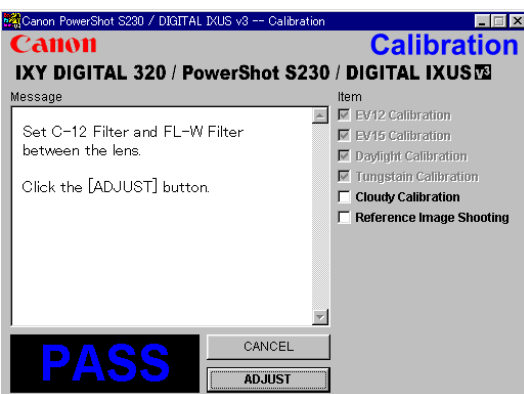
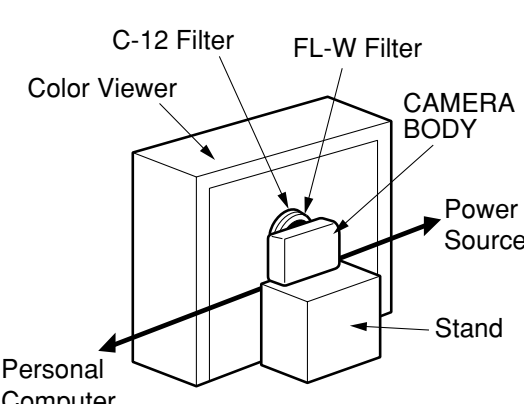

<p>4</p>	<ol style="list-style-type: none"> <li>1. Place the camera so that lens is set against the light source surface of the Brightness Box via the C-12 Filter.</li> <li>2. Set the Brightness Box to EV12.</li> <li>3. Click the “Check” button.</li> <li>4. Check the Brightness level if it is within <math>0 \pm 5</math>.</li> <li>* If not, calibrate the Brightness Box until it becomes within <math>0 \pm 5</math>.</li> <li>5. Click the “NEXT” button.</li> </ol>	
<p>5</p>	<ol style="list-style-type: none"> <li>1. When the message on the right appears, Set the Brightness Box to EV15 and attach the ND-8 Filter while setting the C-12 Filter between the lens.</li> <li>2. Click the “Check” button.</li> <li>3. Check the Brightness level if it is within <math>0 \pm 5</math>.</li> <li>* If not, calibrate the Brightness Box until it becomes within <math>0 \pm 5</math>.</li> <li>4. Click the “NEXT” button.</li> </ol>	
<p>6</p>	<p>When the message on the right appears go to 7.</p>	
<p>7</p>	<ol style="list-style-type: none"> <li>1. Attach the ND-2 Filters between the Lens and the Color Viewer.</li> <li>2. Place the camera so that the lens is set against the center part of the Color Viewer.</li> <li>3. Click the “ADJUST” button.</li> </ol>	

<p>8</p>	<p>When the message on the right appears go to 9.</p>	
<p>9</p>	<ol style="list-style-type: none"> <li>1. Remove the ND-2 Filter.</li> <li>2. Attach the two W-10 Filters between the Lens and the Color Viewer. Place the camera so that the lens is set against the center part of the Color Viewer.</li> <li>3. Click the “ADJUST” button.</li> </ol>	
<p>10</p>	<p>When the message on the right appears go to 11.</p>	
<p>11</p>	<ol style="list-style-type: none"> <li>1. Remove the two W-10 Filters.</li> <li>2. Attach the C-12 and FL-W Filter between the Lens and the Color Viewer. Place the camera so that the lens is set against the center part of the Color Viewer.</li> <li>3. Click the “ADJUST” button.</li> </ol>	

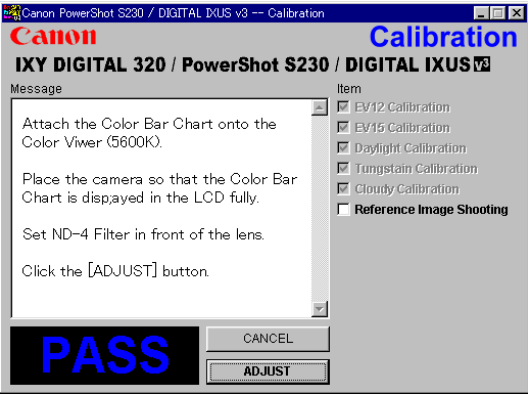
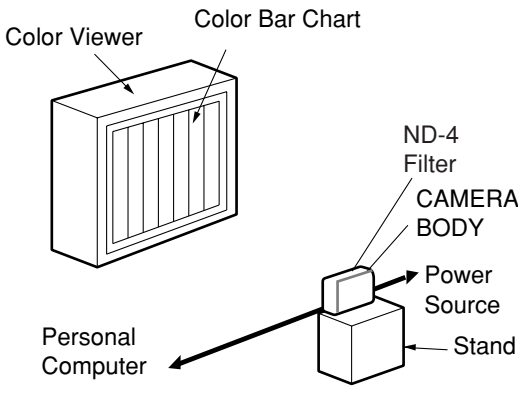
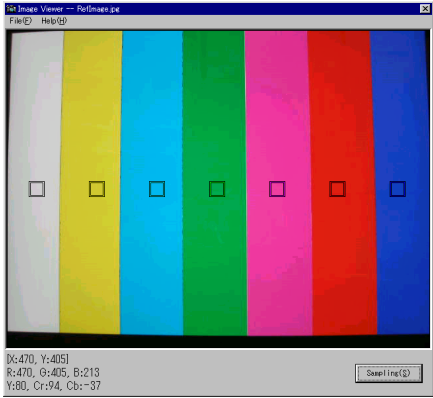
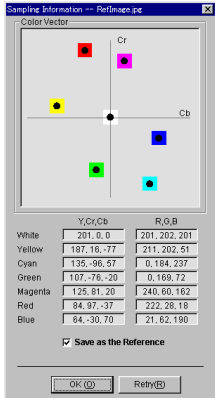
<p>12</p>	<p>When the message on the right appears go to 13.</p>																									
<p>13</p>	<ol style="list-style-type: none"> <li>1. Attach the Color Bar Chart to the Color Viewer.</li> <li>2. Place the camera so that the Viewing image of the color bar chart is the full of LCD with the ND-4 Filter attached.</li> <li>3. Click the “ADJUST” button.</li> </ol>																									
<p>14</p>	<ol style="list-style-type: none"> <li>1. Shift a frame on the displayed screen with a mouse to choose a color of color bar.</li> <li>2. Click the “Sampling” button.</li> </ol>																									
<p>15</p>	<p>Check “Save as Reference”, and click the “OK” button to store the data.</p>	 <table border="1" data-bbox="1013 1744 1204 1862"> <thead> <tr> <th></th> <th>Y,Cr,Cb</th> <th>R,G,B</th> </tr> </thead> <tbody> <tr> <td>White</td> <td>201, 0, 0</td> <td>201, 202, 201</td> </tr> <tr> <td>Yellow</td> <td>187, 16, -77</td> <td>211, 202, 51</td> </tr> <tr> <td>Cyan</td> <td>135, -96, 57</td> <td>0, 184, 237</td> </tr> <tr> <td>Green</td> <td>107, -76, -20</td> <td>0, 169, 72</td> </tr> <tr> <td>Magenta</td> <td>125, 81, 20</td> <td>240, 60, 162</td> </tr> <tr> <td>Red</td> <td>84, 97, -37</td> <td>222, 28, 18</td> </tr> <tr> <td>Blue</td> <td>64, -30, 70</td> <td>21, 62, 180</td> </tr> </tbody> </table>		Y,Cr,Cb	R,G,B	White	201, 0, 0	201, 202, 201	Yellow	187, 16, -77	211, 202, 51	Cyan	135, -96, 57	0, 184, 237	Green	107, -76, -20	0, 169, 72	Magenta	125, 81, 20	240, 60, 162	Red	84, 97, -37	222, 28, 18	Blue	64, -30, 70	21, 62, 180
	Y,Cr,Cb	R,G,B																								
White	201, 0, 0	201, 202, 201																								
Yellow	187, 16, -77	211, 202, 51																								
Cyan	135, -96, 57	0, 184, 237																								
Green	107, -76, -20	0, 169, 72																								
Magenta	125, 81, 20	240, 60, 162																								
Red	84, 97, -37	222, 28, 18																								
Blue	64, -30, 70	21, 62, 180																								

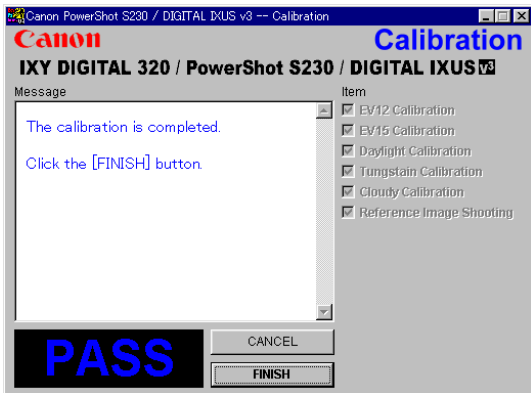
<p>16 When the message on the right appears, click the “FINISH” button. (This ends the “Calibration”.)</p>	
--	--

### 3.5 Adjustment Procedure

#### 3.5.1 CCD Adjustment

■ Tools Used

- Personal Computer
- Adjustment Software
- Compact Power Adapter CA-PS500
- AC Cable
- DC Coupler DR-500
- INTERFACE CABLE IFC-200PCU
- Brightness Box (light source A)
- C-12 Filter

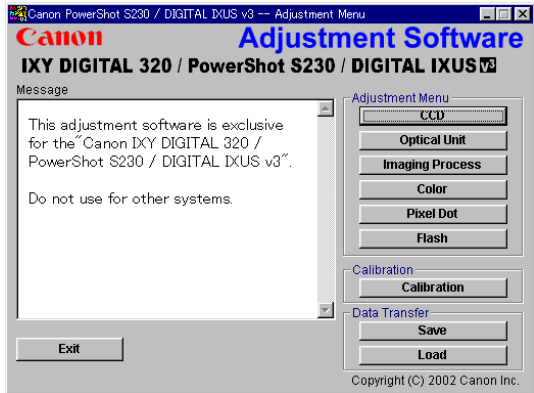
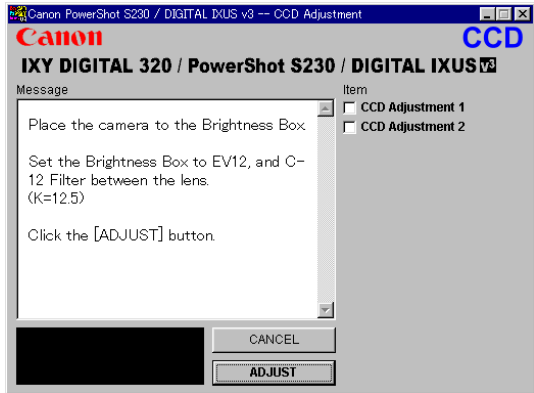
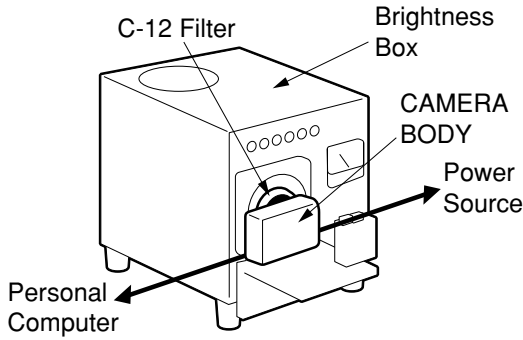
<p>1</p>	<p>Click the “CCD” button.</p>	 <p>The screenshot shows the 'Adjustment Software' window for Canon IXY DIGITAL 320 / PowerShot S230 / DIGITAL IXUS v3. The 'Adjustment Menu' on the right has the 'CCD' button selected. A message box on the left states: 'This adjustment software is exclusive for the "Canon IXY DIGITAL 320 / PowerShot S230 / DIGITAL IXUS v3". Do not use for other systems.' Other menu options include Optical Unit, Imaging Process, Color, Pixel Dot, Flash, Calibration, and Data Transfer (Save, Load). An 'Exit' button is at the bottom left.</p>
<p>2</p>	<p>When the message on the right appears, go to 3.</p>	 <p>The screenshot shows the 'CCD Adjustment' window. The 'Message' box contains: 'Place the camera to the Brightness Box. Set the Brightness Box to EV12, and C-12 Filter between the lens. (K=12.5). Click the [ADJUST] button.' On the right, under 'Item', there are checkboxes for 'CCD Adjustment 1' and 'CCD Adjustment 2'. At the bottom, there are 'CANCEL' and 'ADJUST' buttons.</p>
<p>3</p>	<ol style="list-style-type: none"> <li>1. Place the camera so that lens is set against the light source surface of the Brightness Box via the C-12 Filter.</li> <li>2. Set the Brightness Box to EV12.</li> <li>3. Click the “ADJUST” button.</li> </ol>	 <p>The diagram illustrates the physical setup for the adjustment. A 'CAMERA BODY' is positioned inside a 'Brightness Box'. A 'C-12 Filter' is placed between the camera lens and the light source surface of the box. A 'Power Source' is connected to the camera, and a 'Personal Computer' is connected to the camera via a cable.</p>

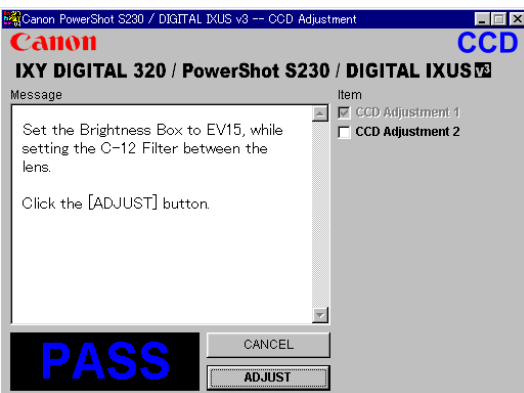
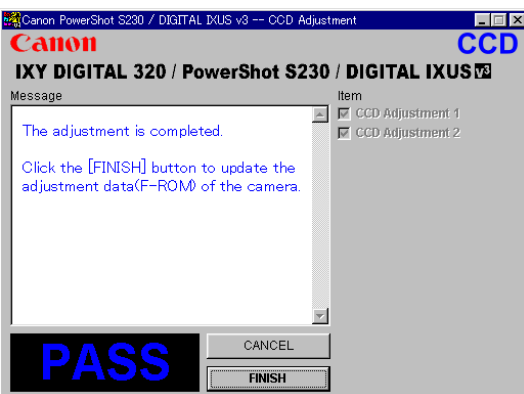
<p>4</p>	<p>When the message on the right appears, Set the Brightness Box to EV15 while setting the C-12 Filter between the lens. Click the “ADJUST” button.</p>	 <p>The screenshot shows a software window titled "Canon PowerShot S230 / DIGITAL IXUS v3 -- CCD Adjustment". The window has a "Message" pane on the left and an "Item" list on the right. The message reads: "Set the Brightness Box to EV15, while setting the C-12 Filter between the lens. Click the [ADJUST] button." The "Item" list contains "CCD Adjustment 1" (checked) and "CCD Adjustment 2" (unchecked). At the bottom, there is a large blue "PASS" button, a "CANCEL" button, and an "ADJUST" button.</p>
<p>5</p>	<p>When the message on the right appears, click the “FINISH” button. (This ends the “CCD” Adjustment.)</p>	 <p>The screenshot shows the same software window as above. The "Message" pane now reads: "The adjustment is completed. Click the [FINISH] button to update the adjustment data(F-ROM) of the camera." The "Item" list remains the same. At the bottom, there is a large blue "PASS" button, a "CANCEL" button, and a "FINISH" button.</p>

### 3.5.2 Optical Unit Adjustment

■ Tools Used

- Personal Computer
- Adjustment Software
- Compact Power Adapter CA-PS500
- AC Cable
- DC Coupler DR-500
- INTERFACE CABLE IFC-200PCU
- Zoom/AF Chart
- Tripod

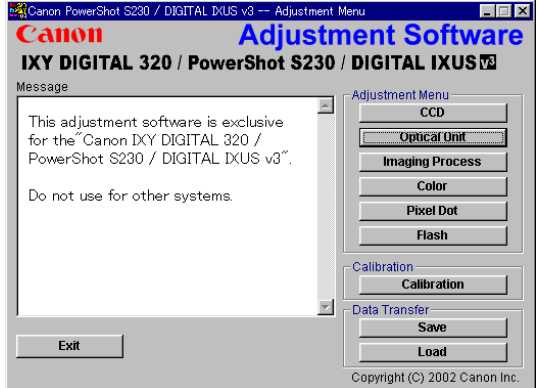
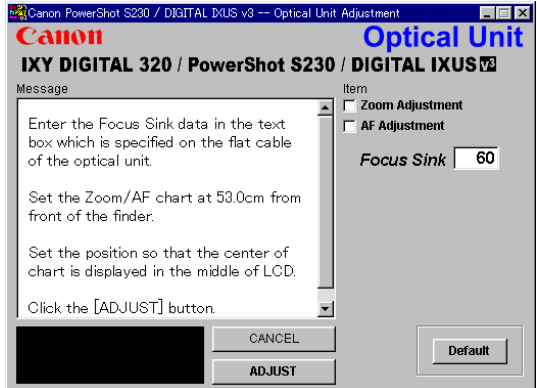
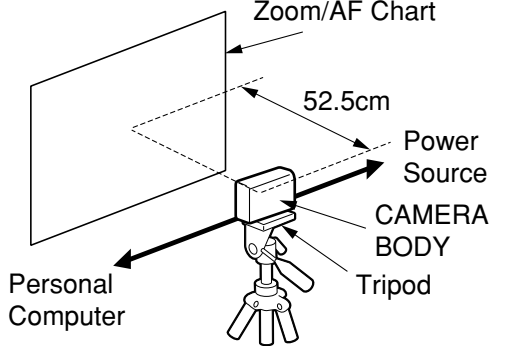
<p>1</p>	<p>Click the “Optical Unit” button.</p>	 <p>The screenshot shows the 'Adjustment Menu' window. The 'Optical Unit' button is highlighted with a grey background. Other buttons include CCD, Imaging Process, Color, Pixel Dot, Flash, Calibration, Save, and Load. A message box on the left contains text about software exclusivity.</p>
<p>2</p>	<p>When the message on the right appears, Enter the value which is written on the flat cable of the Optical Unit in the text box, go to 3.</p>	 <p>The screenshot shows the 'Optical Unit' window. The 'Focus Sink' input field is set to the value '60'. The message box on the left provides instructions on how to use the chart and adjust the camera. Buttons for 'CANCEL', 'ADJUST', and 'Default' are visible at the bottom.</p>
<p>3</p>	<ol style="list-style-type: none"> <li>1. Place the Zoom/AF Chart at 53.0cm away from the front of the camera finder.             <ul style="list-style-type: none"> <li>* Place the Zoom/AF Chart on a plain color wall or equivalent.</li> <li>* Adjust the light so that the brightness of the chart will be about EV8.5.</li> </ul> </li> <li>2. Adjust the position of the camera finely so that the center of the Auto Focus Chart is aligned with the center of the LCD.</li> <li>3. Click the “ADJUST” button.</li> </ol> <p>* When the adjustment does not work, click the “Default” button.</p>	 <p>The diagram shows a camera on a tripod. A 'Zoom/AF Chart' is positioned to the left of the camera. A dashed line indicates a distance of '52.5cm' between the camera's lens and the chart. A 'Personal Computer' is connected to the camera via a cable. A 'Power Source' is also connected to the camera. The camera is labeled 'CAMERA BODY' and the tripod is labeled 'Tripod'.</p>

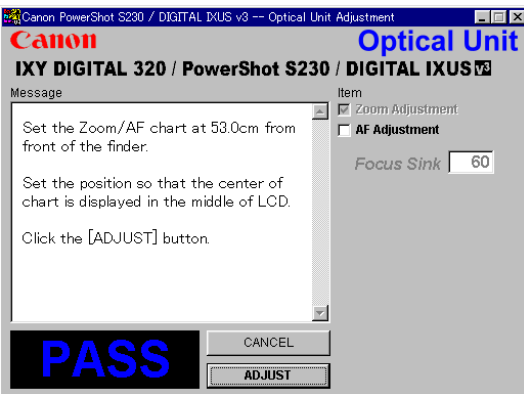
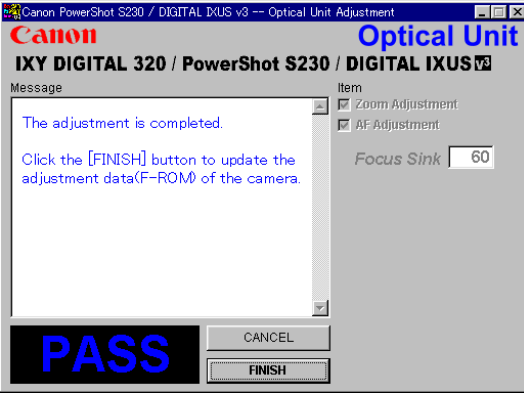
<p>4</p>	<p>When the message on the right appears, click the “ADJUST” button.</p>	 <p>The screenshot shows the 'Optical Unit Adjustment' window for a Canon camera. The title bar reads 'Canon PowerShot S230 / DIGITAL IXUS v3 -- Optical Unit Adjustment'. The main area is titled 'Optical Unit' and 'IXY DIGITAL 320 / PowerShot S230 / DIGITAL IXUS'. A 'Message' box contains the following text: 'Set the Zoom/AF chart at 53.0cm from front of the finder.', 'Set the position so that the center of chart is displayed in the middle of LCD.', and 'Click the [ADJUST] button.' To the right, under 'Item', there are checkboxes for 'Zoom Adjustment' (checked) and 'AF Adjustment' (unchecked), and a 'Focus Sink' value of 60. At the bottom, there is a large blue 'PASS' button, a 'CANCEL' button, and an 'ADJUST' button.</p>
<p>5</p>	<p>When the message on the right appears, click the “FINISH” button. (This ends the “Optical Unit” Adjustment.)</p>	 <p>The screenshot shows the 'Optical Unit Adjustment' window. The 'Message' box now contains: 'The adjustment is completed.', 'Click the [FINISH] button to update the adjustment data(F-ROM) of the camera.' The 'AF Adjustment' checkbox is now checked. The 'Focus Sink' value remains at 60. At the bottom, there is a large blue 'PASS' button, a 'CANCEL' button, and a 'FINISH' button.</p>



### 3.5.3 Imaging Process Adjustment

■ Tools Used

- Personal Computer
- Adjustment Software
- Compact Power Adapter CA-PS500
- AC Cable
- DC Coupler DR-500
- INTERFACE CABLE IFC-200PCU
- Color Viewer (5600° K)
- W-10 Filter (2 pcs.)
- C-12 Filter
- FL-W Filter
- ND-2 Filter

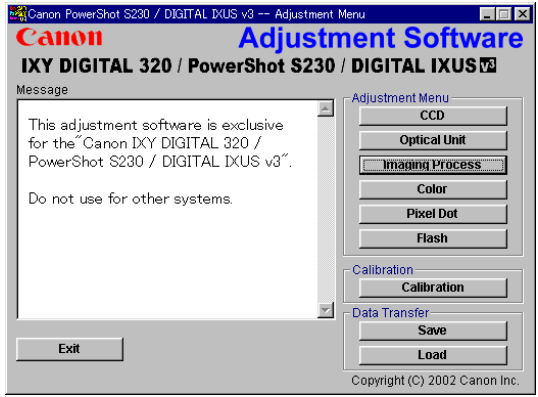
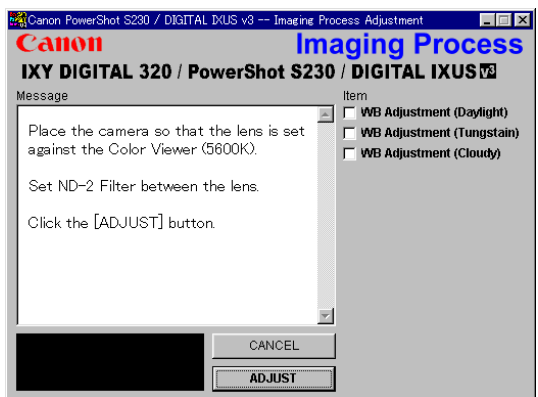
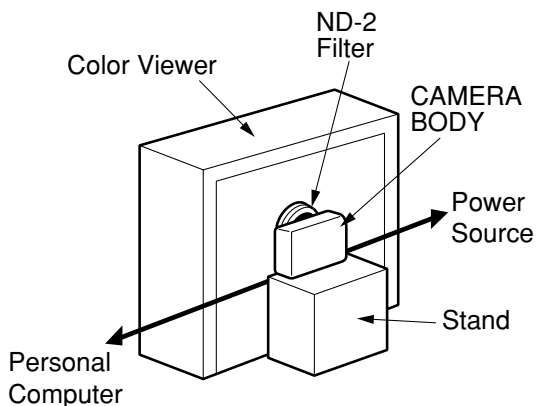
<p>1</p>	<p>Click the “Imaging Process” button.</p>	 <p>The screenshot shows the 'Adjustment Menu' window. The title bar reads 'Canon PowerShot S230 / DIGITAL IXUS v3 -- Adjustment Menu'. The main window has a 'Message' box on the left and a list of adjustment options on the right. The options are: CCD, Optical Unit, Imaging Process (highlighted), Color, Pixel Dot, and Flash. Below these are sections for 'Calibration' (with a 'Calibration' button) and 'Data Transfer' (with 'Save' and 'Load' buttons). An 'Exit' button is at the bottom left. Copyright (C) 2002 Canon Inc. is at the bottom right.</p>
<p>2</p>	<p>When the message on the right appears, go to 3.</p>	 <p>The screenshot shows the 'Imaging Process Adjustment' window. The title bar reads 'Canon PowerShot S230 / DIGITAL IXUS v3 -- Imaging Process Adjustment'. The main window has a 'Message' box on the left and a list of items on the right. The message reads: 'Place the camera so that the lens is set against the Color Viewer (5600K). Set ND-2 Filter between the lens. Click the [ADJUST] button.' The items on the right are: WB Adjustment (Daylight), WB Adjustment (Tungstain), and WB Adjustment (Cloudy). At the bottom are 'CANCEL' and 'ADJUST' buttons.</p>
<p>3</p>	<ol style="list-style-type: none"> <li>1. Attach the ND-2 Filters between the Lens and the Color Viewer.</li> <li>2. Place the camera so that the lens is set against the center part of the Color Viewer.</li> <li>3. Click the “ADJUST” button.</li> </ol>	 <p>The diagram illustrates the physical setup for the adjustment. A 'Color Viewer' is shown on the left. An 'ND-2 Filter' is placed between the 'CAMERA BODY' and the 'Color Viewer'. The 'CAMERA BODY' is mounted on a 'Stand'. A 'Power Source' is connected to the camera. A 'Personal Computer' is connected to the camera via an interface cable.</p>

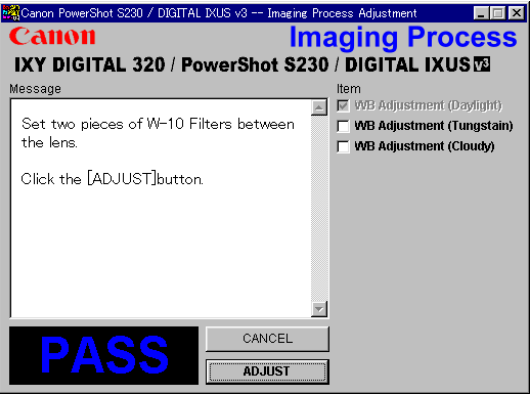
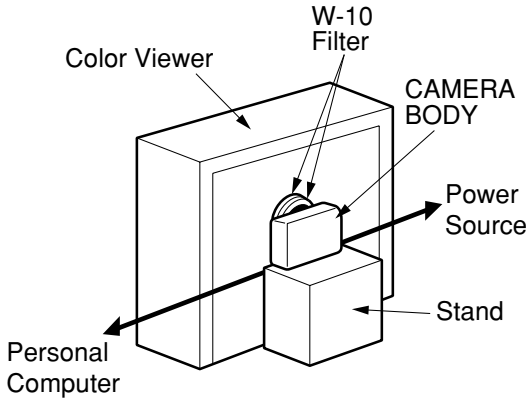
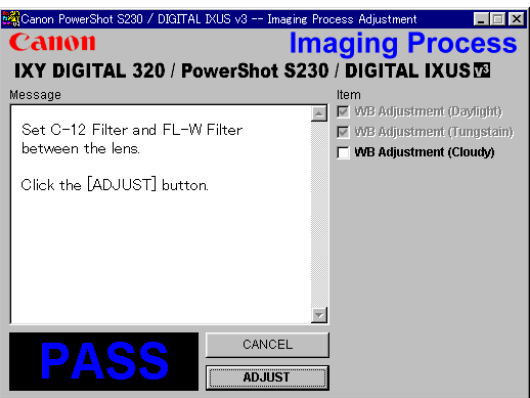
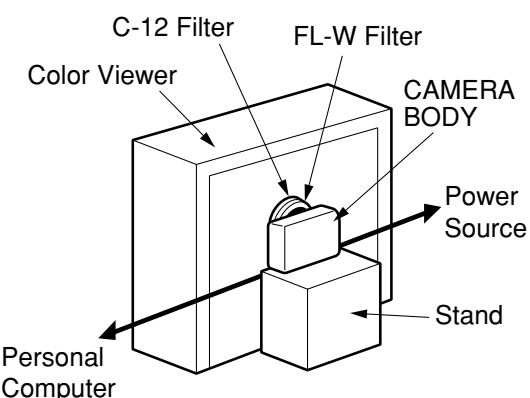
<p>4</p>	<p>When the message on the right appears, go to 5.</p>	
<p>5</p>	<ol style="list-style-type: none"> <li>1. Remove the ND-2 Filter.</li> <li>2. Attach the two W-10 Filters between the Lens and the Color Viewer. Place the camera so that the lens is set against the center part of the Color Viewer.</li> <li>3. Click the “ADJUST” button.</li> </ol>	
<p>6</p>	<p>When the message on the right appears, go to 7.</p>	
<p>7</p>	<ol style="list-style-type: none"> <li>1. Remove the two W-10 Filters.</li> <li>2. Attach the C-12 and FL-W Filter between the Lens and the Color Viewer. Place the camera so that the lens is set against the center part of the Color Viewer.</li> <li>3. Click the “ADJUST” button.</li> </ol>	

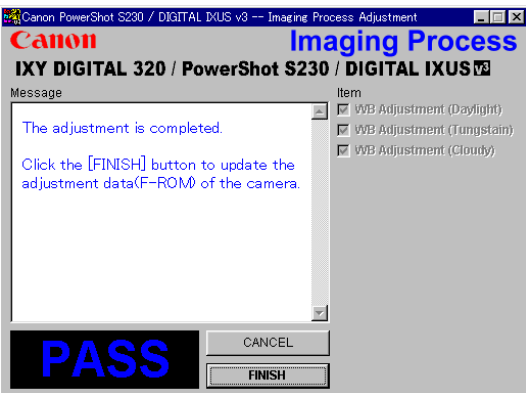
8	When the message on the right appears, click the “FINISH” button. (This ends the “Imaging Process” Adjustment.)	
---	--	--

### 3.5.4 Color Adjustment

■ Tools Used

- Personal Computer
- Adjustment Software
- Compact Power Adapter CA-PS500
- AC Cable
- DC Coupler DR-500
- INTERFACE CABLE IFC-200PCU
- Color Viewer (5600° K)
- Color Bar Chart
- ND-4 Filter

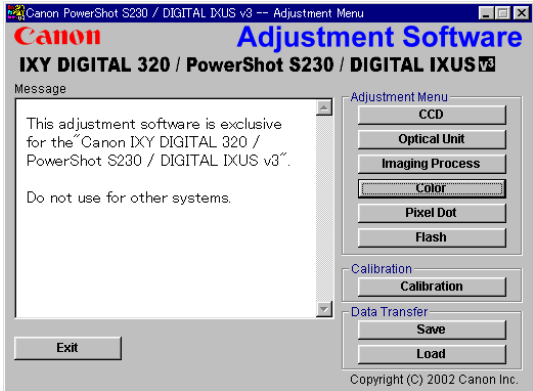
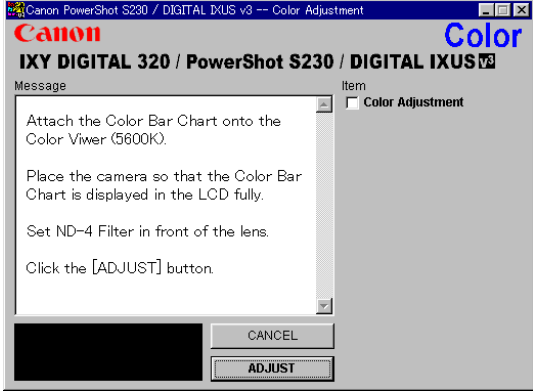
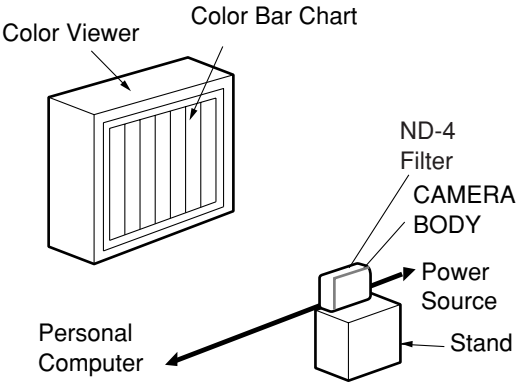
<p>1</p>	<p>Click the “Color” button.</p>	 <p>The screenshot shows the 'Adjustment Menu' window of the Canon Adjustment Software. The 'Color' button is highlighted in the 'Adjustment Menu' section. Other buttons include CCD, Optical Unit, Imaging Process, Pixel Dot, Flash, Calibration, and Data Transfer (Save, Load). A message box contains text about software exclusivity for Canon IXY DIGITAL 320 / PowerShot S230 / DIGITAL IXUS v3.</p>
<p>2</p>	<p>When the message on the right appears, go to 3.</p>	 <p>The screenshot shows the 'Color Adjustment' window. The 'Color Adjustment' checkbox is checked. The message box contains instructions: 'Attach the Color Bar Chart onto the Color Viewer (5600K). Place the camera so that the Viewing image of the color bar chart is the full of LCD with the ND-4 Filter attached. Set ND-4 Filter in front of the lens. Click the [ADJUST] button.' Buttons for CANCEL and ADJUST are visible.</p>
<p>3</p>	<ol style="list-style-type: none"> <li>1. Attach the Color Bar Chart to the Color Viewer.</li> <li>2. Place the camera so that the Viewing image of the color bar chart is the full of LCD with the ND-4 Filter attached.</li> <li>3. Click the “ADJUST” button.</li> </ol>	 <p>The diagram illustrates the physical setup. A 'Color Viewer' is shown with a 'Color Bar Chart' attached to its front. Below it, a 'CAMERA BODY' is mounted on a 'Stand'. An 'ND-4 Filter' is placed in front of the camera lens. A 'Power Source' is connected to the camera. A 'Personal Computer' is connected to the camera via an interface cable.</p>

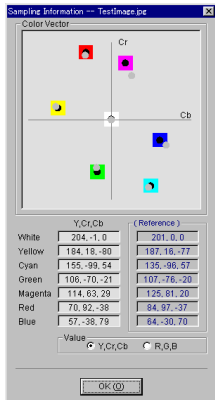
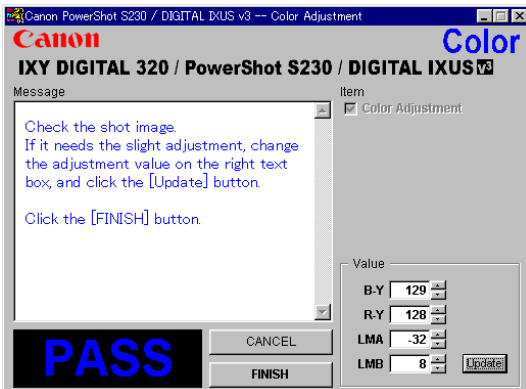
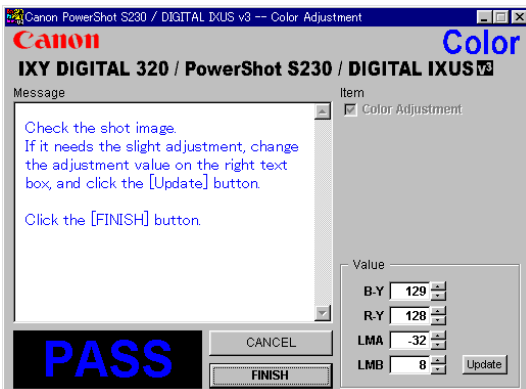
<p>4</p>	<p>1. Shift a frame on the displayed screen with a mouse to choose a color of color bar. 2. Click the “Sampling” button.</p>																									
<p>5</p>	<p>Check “Yellow and Red”, and click the “OK” button. If these data are within specifications, go to 7.</p> <p>* Specification Ave_Cr = Reference Camera ± 10 Ave_Cb = Reference Camera ± 10</p>	 <table border="1" data-bbox="1007 878 1222 995"> <thead> <tr> <th></th> <th>Y,Cr,Cb</th> <th>(Reference)</th> </tr> </thead> <tbody> <tr> <td>White</td> <td>204, 0, 0</td> <td>201, 0, 0</td> </tr> <tr> <td>Yellow</td> <td>184, 19, -80</td> <td>187, 16, -77</td> </tr> <tr> <td>Cyan</td> <td>155, -99, 54</td> <td>135, -96, 57</td> </tr> <tr> <td>Green</td> <td>106, -70, -21</td> <td>107, -76, -20</td> </tr> <tr> <td>Magenta</td> <td>114, 63, 29</td> <td>125, 61, 20</td> </tr> <tr> <td>Red</td> <td>70, 92, -38</td> <td>84, 97, -37</td> </tr> <tr> <td>Blue</td> <td>57, -38, 79</td> <td>64, -30, 70</td> </tr> </tbody> </table>		Y,Cr,Cb	(Reference)	White	204, 0, 0	201, 0, 0	Yellow	184, 19, -80	187, 16, -77	Cyan	155, -99, 54	135, -96, 57	Green	106, -70, -21	107, -76, -20	Magenta	114, 63, 29	125, 61, 20	Red	70, 92, -38	84, 97, -37	Blue	57, -38, 79	64, -30, 70
	Y,Cr,Cb	(Reference)																								
White	204, 0, 0	201, 0, 0																								
Yellow	184, 19, -80	187, 16, -77																								
Cyan	155, -99, 54	135, -96, 57																								
Green	106, -70, -21	107, -76, -20																								
Magenta	114, 63, 29	125, 61, 20																								
Red	70, 92, -38	84, 97, -37																								
Blue	57, -38, 79	64, -30, 70																								
<p>6</p>	<p>1. Confirm to see that the image on the PC monitor satisfies the specifications. 2. If the image on the PC monitor does not satisfy the specifications, change the data using UP, DOWN button or change the data directly by typing the data in the text box. Then click the “UPDATE” button.</p>																									
<p>7</p>	<p>When the adjustment is completed, click the “FINISH” button. (This ends the “Color” Adjustment.)</p>																									

### 3.5.5 Pixel Dot Adjustment

■ Tools Used

- Personal Computer
- Adjustment Software
- Compact Power Adapter CA-PS500
- AC Cable
- DC Coupler DR-500
- INTERFACE CABLE IFC-200PCU
- Brightness Box (Light source A)
- C-12 Filter
- Light-Shielding Cloth (500 × 500 or larger)

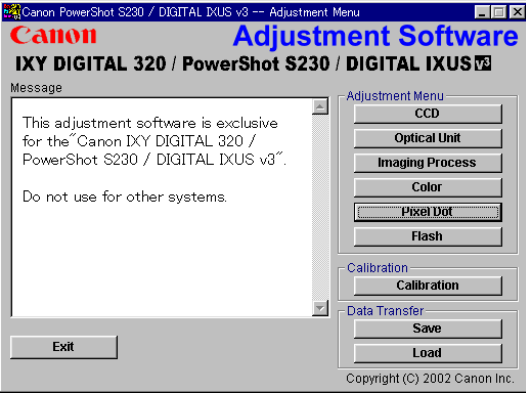
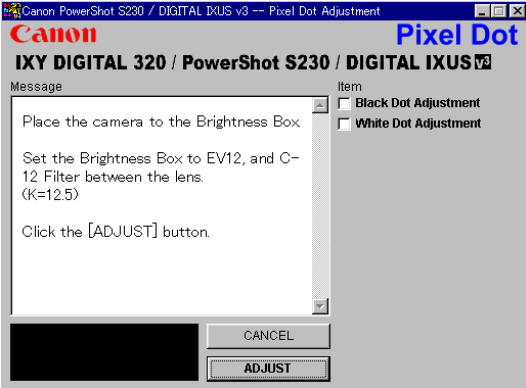
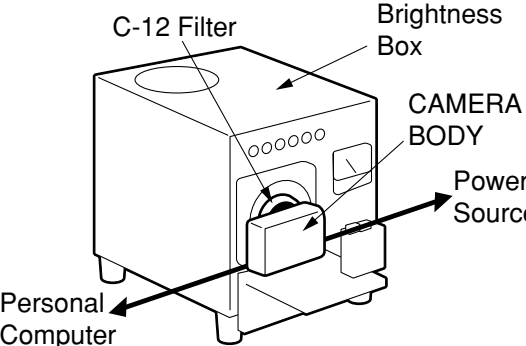
<p>1</p>	<p>Click the “Pixel Dot” button.</p>	 <p>The screenshot shows the 'Adjustment Menu' window. The title bar reads 'Canon PowerShot S230 / DIGITAL IXUS v3 -- Adjustment Menu'. The main window has a 'Message' area on the left and an 'Adjustment Menu' on the right. The 'Adjustment Menu' includes buttons for 'CCD', 'Optical Unit', 'Imaging Process', 'Color', 'Pixel Dot' (which is highlighted with a grey background), and 'Flash'. Below this are sections for 'Calibration' (with a 'Calibration' button) and 'Data Transfer' (with 'Save' and 'Load' buttons). An 'Exit' button is at the bottom left. Copyright (C) 2002 Canon Inc. is at the bottom right.</p>
<p>2</p>	<p>When the message on the right appears, go to 3.</p>	 <p>The screenshot shows the 'Pixel Dot Adjustment' dialog box. The title bar reads 'Canon PowerShot S230 / DIGITAL IXUS v3 -- Pixel Dot Adjustment'. The main window has a 'Message' area on the left and an 'Item' area on the right. The 'Message' area contains the text: 'Place the camera to the Brightness Box. Set the Brightness Box to EV12, and C-12 Filter between the lens. (K=12.5) Click the [ADJUST] button.' The 'Item' area has two checkboxes: 'Black Dot Adjustment' and 'White Dot Adjustment', both of which are unchecked. At the bottom, there are 'CANCEL' and 'ADJUST' buttons. A black rectangular area is visible at the bottom left of the dialog box.</p>
<p>3</p>	<ol style="list-style-type: none"> <li>1. Place the camera so that lens is set against the light source surface of the Brightness Box via the C-12 Filter.</li> <li>2. Set the Brightness Box to EV12.</li> <li>3. Click the “ADJUST” button.</li> </ol>	 <p>The diagram shows a 3D perspective view of the camera setup. A 'CAMERA BODY' is positioned inside a 'Brightness Box'. A 'C-12 Filter' is placed between the camera lens and the light source surface of the box. A 'Personal Computer' is connected to the camera via an interface cable. A 'Power Source' is connected to the camera. Arrows point from the labels to the corresponding components in the diagram.</p>

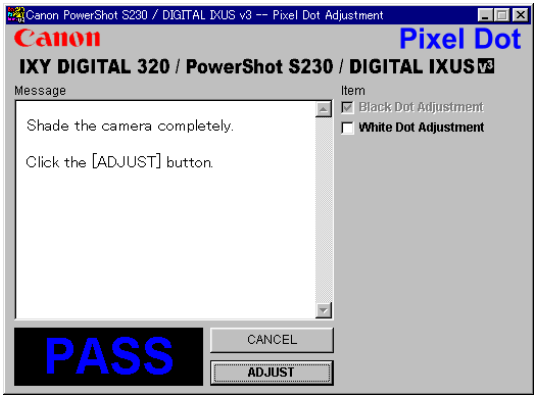
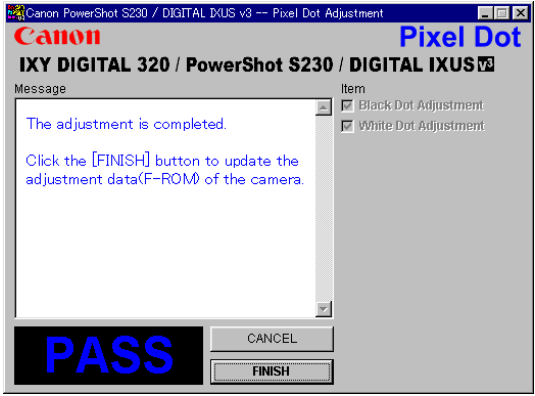
<p>4</p>	<ol style="list-style-type: none"> <li>1. When the message on the right appears, cover the camera with the Light-Shielding Cloth so that the no light reasons the CCD.</li> <li>2. Click the “ADJUST” button.</li> </ol>	 <p>The screenshot shows a software window titled 'Pixel Dot Adjustment' for a Canon PowerShot S230. The window contains a 'Message' box with the text: 'Shade the camera completely. Click the [ADJUST] button.' To the right, there are checkboxes for 'Black Dot Adjustment' and 'White Dot Adjustment'. At the bottom, there are three buttons: 'PASS' (highlighted in blue), 'CANCEL', and 'ADJUST'.</p>
<p>5</p>	<p>When the message on the right appears, click the “FINISH” button. (This ends the “Pixel Dot” Adjustment.)</p>	 <p>The screenshot shows the same software window. The 'Message' box now reads: 'The adjustment is completed. Click the [FINISH] button to update the adjustment data(F-ROM) of the camera.' The 'FINISH' button at the bottom is now highlighted in blue.</p>

### 3.5.6 Flash Adjustment

■ Tools Used

- Personal Computer
- Adjustment Software
- Compact Power Adapter CA-PS500
- AC Cable
- DC Coupler DR-500
- INTERFACE CABLE IFC-200PCU
- 18% Gray Chart
- Tripod

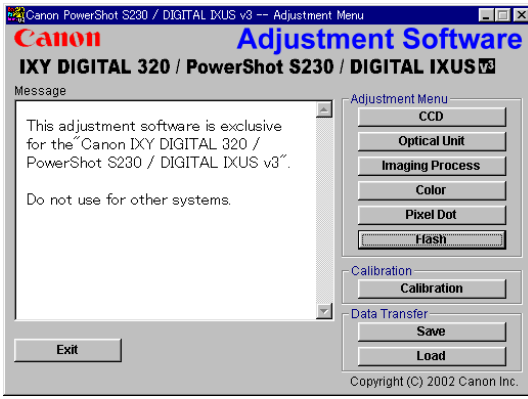
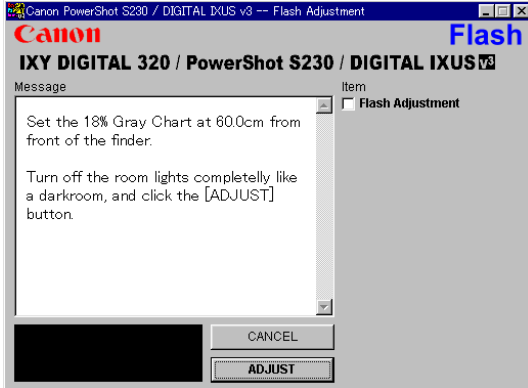
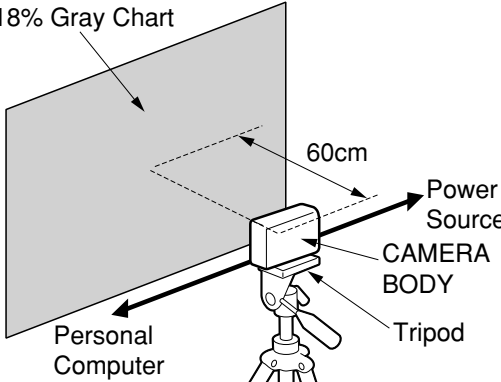
<p>1 Click the “Flash” button.</p>	 <p>The screenshot shows the 'Adjustment Software' window for Canon IXY DIGITAL 320 / PowerShot S230 / DIGITAL IXUS v3. The 'Adjustment Menu' on the right has the 'Flash' button highlighted. A message box on the left states: 'This adjustment software is exclusive for the Canon IXY DIGITAL 320 / PowerShot S230 / DIGITAL IXUS v3. Do not use for other systems.' Other menu options include CCD, Optical Unit, Imaging Process, Color, Pixel Dot, Calibration, and Data Transfer.</p>
<p>2 When the message on the right appears, go to 3.</p>	 <p>The screenshot shows the 'Flash Adjustment' window. The message box contains: 'Set the 18% Gray Chart at 60.0cm from front of the finder. Turn off the room lights completely like a darkroom, and click the [ADJUST] button.' The 'ADJUST' button is highlighted. There is also a 'CANCEL' button and a checkbox for 'Flash Adjustment'.</p>
<p>3</p> <ol style="list-style-type: none"> <li>1. Set 18% Gray Chart 60cm from the Finder front.</li> <li>2. Make the room as dark as a darkroom.</li> <li>3. Click the “ADJUST” button.</li> </ol>	 <p>The diagram illustrates the physical setup for the flash adjustment process. It shows a camera body mounted on a tripod. A 18% Gray Chart is positioned 60cm in front of the camera's finder. A power source is connected to the camera. A personal computer is also shown connected to the camera. Labels include: 18% Gray Chart, 60cm, Power Source, CAMERA BODY, Tripod, and Personal Computer.</p>

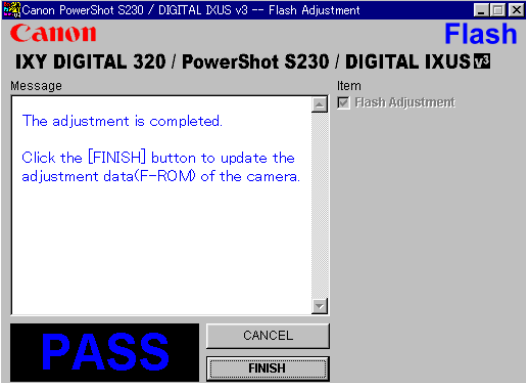

<p>4 When the message on the right appears, click the “FINISH” button. (This ends the “Flash” Adjustment.)</p>	
--	--

### 3.5.7 Checking of sound recording/output

It is not required to adjust the recording/output (volume, etc.) of sound.  
Check the camera if the sound is recorded/play-backed properly.

# CHAPTER 4. PARTS CATALOG

## CONTENTS

PowerShot S230/DIGITAL IXUS v3/IXY DIGITAL 320

Casing Parts -----	Pg1
Internal Parts-1 -----	Pg2
Internal Parts-2 -----	Pg3
OPTICAL UNIT -----	Pg4
Accessories-1 -----	Pg5
Accessories-2 -----	Pg6
Accessories-3 -----	Pg7
Service Tools-----	Pg8

### CLASS凡例

- A: 使用頻度 高
- B: 使用頻度 中
- C: 使用頻度 低
- D: 安全規格部品
- E: 消耗部品
- F: 標準ネジ、ワッシャー
- S: 供給制限品

### Category of CLASS

- A: Frequency of use: High
- B: Frequency of use: Middle
- C: Frequency of use: Low
- D: Safety-related critical parts
- E: Consumable parts
- F: Standard screws and washers
- S: Supply of the parts is limited



# Casing Parts

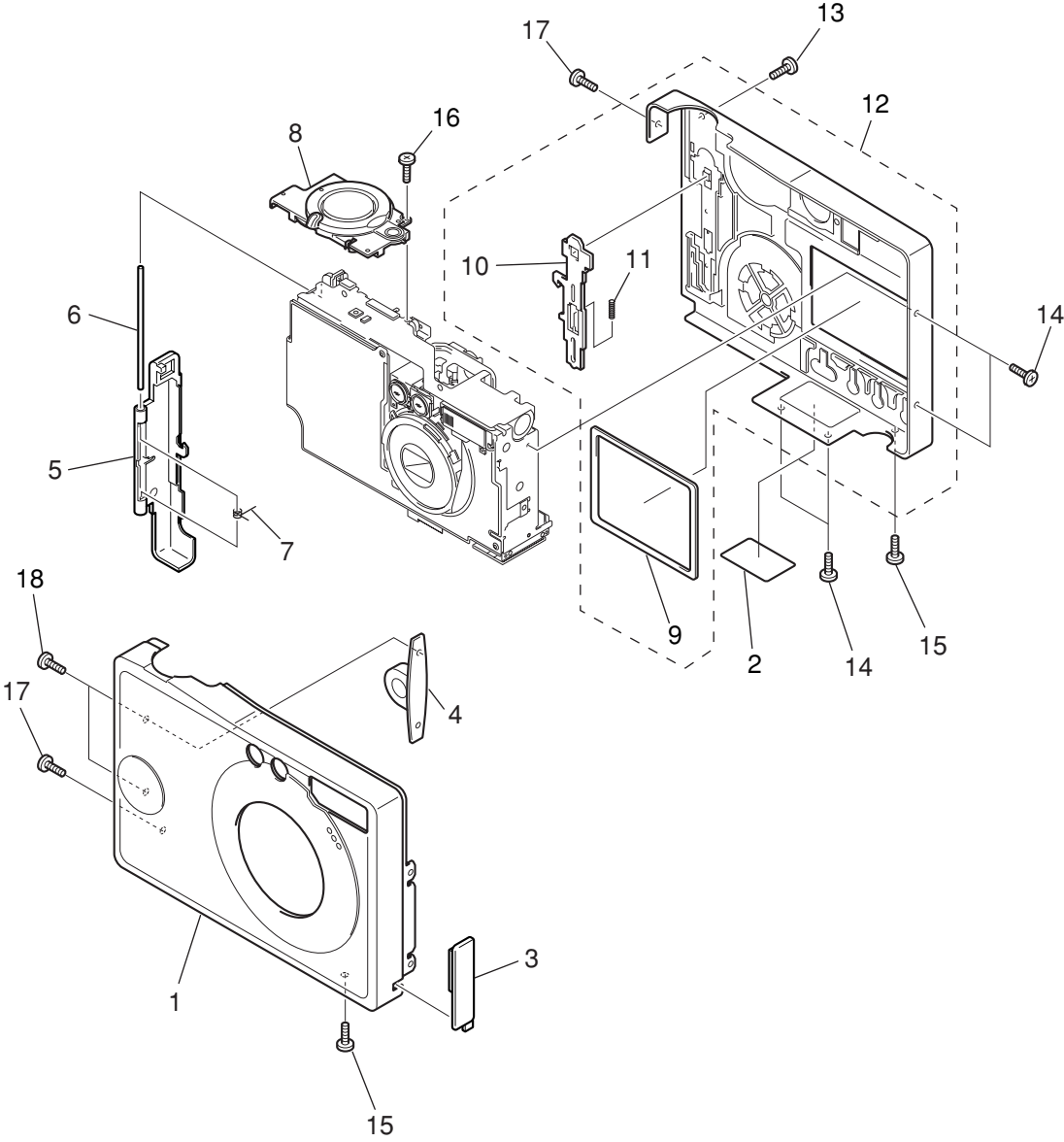

# PARTS LIST

SYMBOL	PARTS NO.	CLASS	QTY	DESCRIPTION	REMARKS
1	CM1-1456-000	B	1	FRONT COVER UNIT	IXY DIGITAL 320
	CM1-1457-000	B	1	FRONT COVER UNIT	PowerShot S230
	CM1-1458-000	B	1	FRONT COVER UNIT	DIGITAL IXUS v3
2	CY1-6198-000	B	1	PLATE, BODY NUMBER	
3	CD1-4240-000	B	1	COVER, JACK	
4	CD3-0464-000	B	1	RING, STRAP	
5	CD1-4236-020	B	1	COVER, CF	
6	CD1-4237-000	C	1	SHAFT, CF COVER	
7	CS8-6162-000	C	1	SPRING, CF COVER	
8	CM1-1459-000	B	1	SHUTTER BUTTON UNIT	
9	CD1-4249-000	C	1	SPACER, LCD	
10	CD1-4200-000	C	1	LOCK, CF COVER	
11	CS8-5264-000	C	1	SPRING, CF LOCK	
12	CM1-1337-000	B	1	REAR COVER UNIT	
13	CD1-4183-000	F	1	SCREW	
14	CD1-3109-000	F	4	SCREW	
15	CD1-4248-000	F	2	SCREW	
16	XA4-9170-409	F	1	SCREW	
17	CD1-3112-000	F	2	SCREW	
18	CD1-3110-000	F	2	SCREW	

# Internal Parts-1

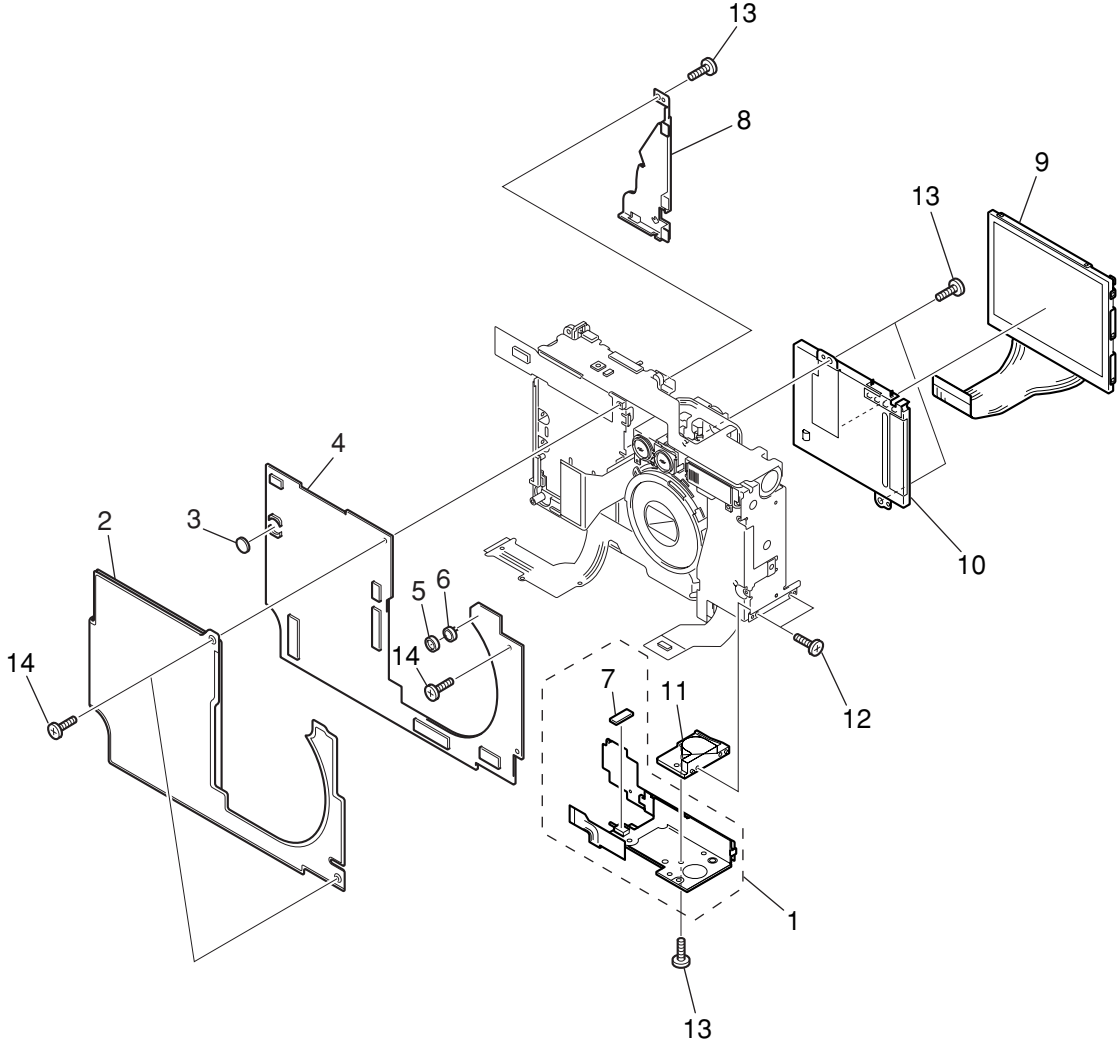

## PARTS LIST

SYMBOL	PARTS NO.	CLASS	QTY	DESCRIPTION	REMARKS
1	CM1-1571-000	C	1	OPERATION KEY UNIT	
2	CL1-1113-000	C	1	SHEET, SHIELD	
3	WK1-5140-000	C	1	BATTERY, LITHIUM (2ND)	
4	CM1-1450-000	C	1	PCB ASS'Y, MAIN	
5	CD1-4241-000	C	1	HOLDER, MICROPHONE	
6	WR1-5084-000	C	1	MICROPHONE UNIT	
7	CD1-4244-000	C	1	SHEET, DUSTPROOF	
8	CD1-4234-000	C	1	PLATE, OPERATION	
9	WG2-5226-000	C	1	PANEL, LCD	
	WG2-5226-001	C	1	PANEL, LCD (SELECTION)	
10	CM1-1446-000	C	1	BACK LIGHT UNIT	
11	CD1-4232-000	C	1	SOCKET, TRIPOD	
12	XA1-7170-307	F	2	SCREW	
13	CD1-3108-000	F	4	SCREW	
14	XA1-7170-357	F	3	SCREW	



# Internal Parts-2

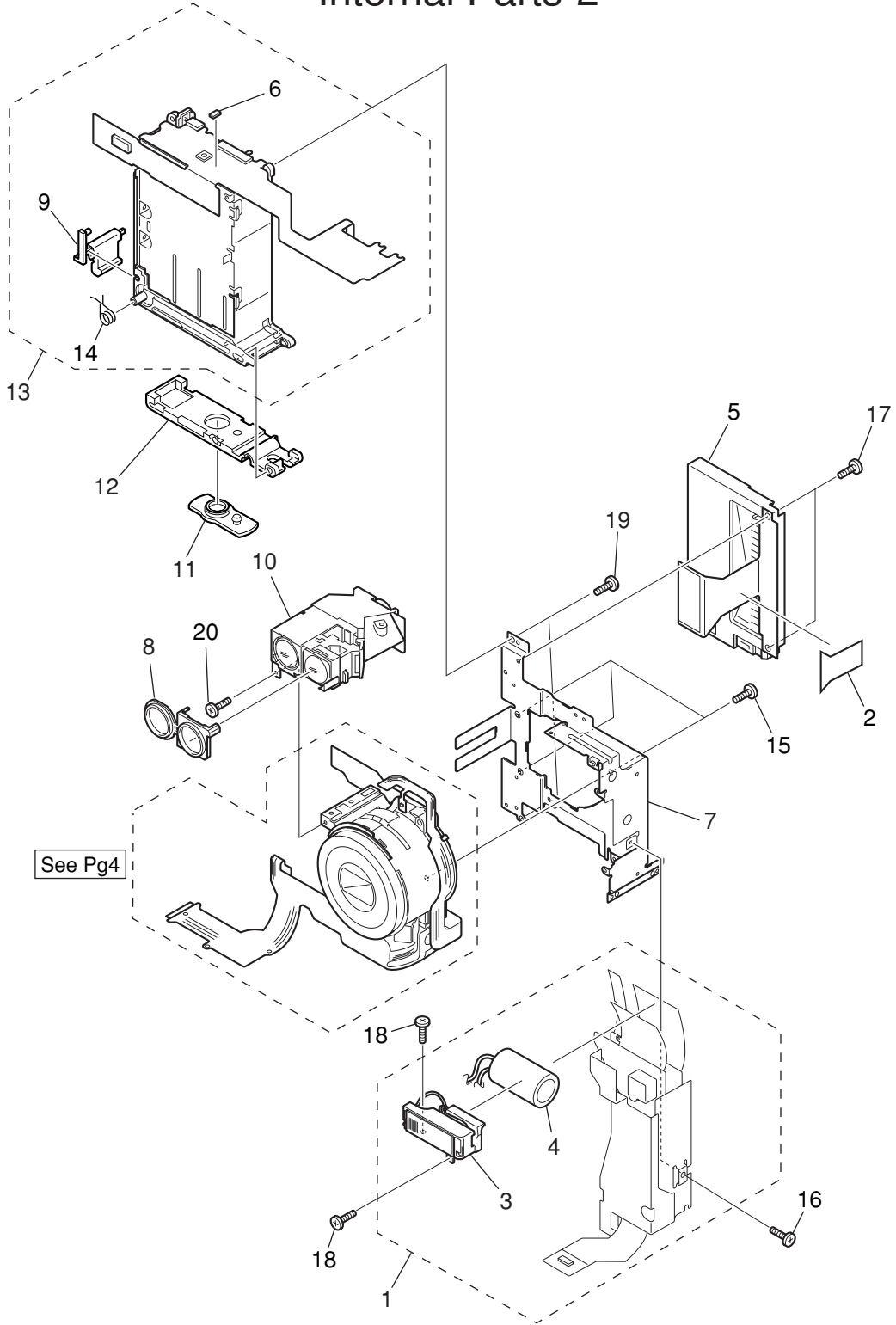

## PARTS LIST

SYMBOL	PARTS NO.	CLASS	QTY	DESCRIPTION	REMARKS
1	CM1-1447-000	C	1	FLASH/DC UNIT	
2	CD1-4444-000	C	1	SHEET, NOISE ABSORPTION	
3	CM1-1342-000	C	1	FLASH UNIT	
4	CK9-0308-000	C	1	CAPACITOR, ELECT.	330V 80 $\mu$ F
5	CM1-1452-000	C	1	CF UNIT	
6	WD1-5064-000	C	1	FUSE, MATSU.DENKI UNHH206	
7	CD1-4231-010	C	1	FRAME, MAIN	
8	CD1-4180-000	C	1	RUBBER, FINDER	
9	CD1-4217-000	C	1	LOCK, BATTERY	
10	CM1-1340-010	C	1	FINDER UNIT	
11	CD1-4239-000	B	1	COVER, DC COUPLER	
12	CD1-4238-000	B	1	COVER, BATTERY	
13	CM1-1460-000	C	1	BATTERY BOX UNIT	
14	CS8-6161-000	C	1	SPRING, BATTERY LOCK	
15	XA4-5170-309	F	3	SCREW	
16	CD1-3108-000	F	1	SCREW	
17	CD1-3105-000	F	2	SCREW	
18	XA1-7140-307	F	2	SCREW	
19	XA4-9170-359	F	2	SCREW	
20	XA4-9140-357	F	1	SCREW	

# OPTICAL UNIT

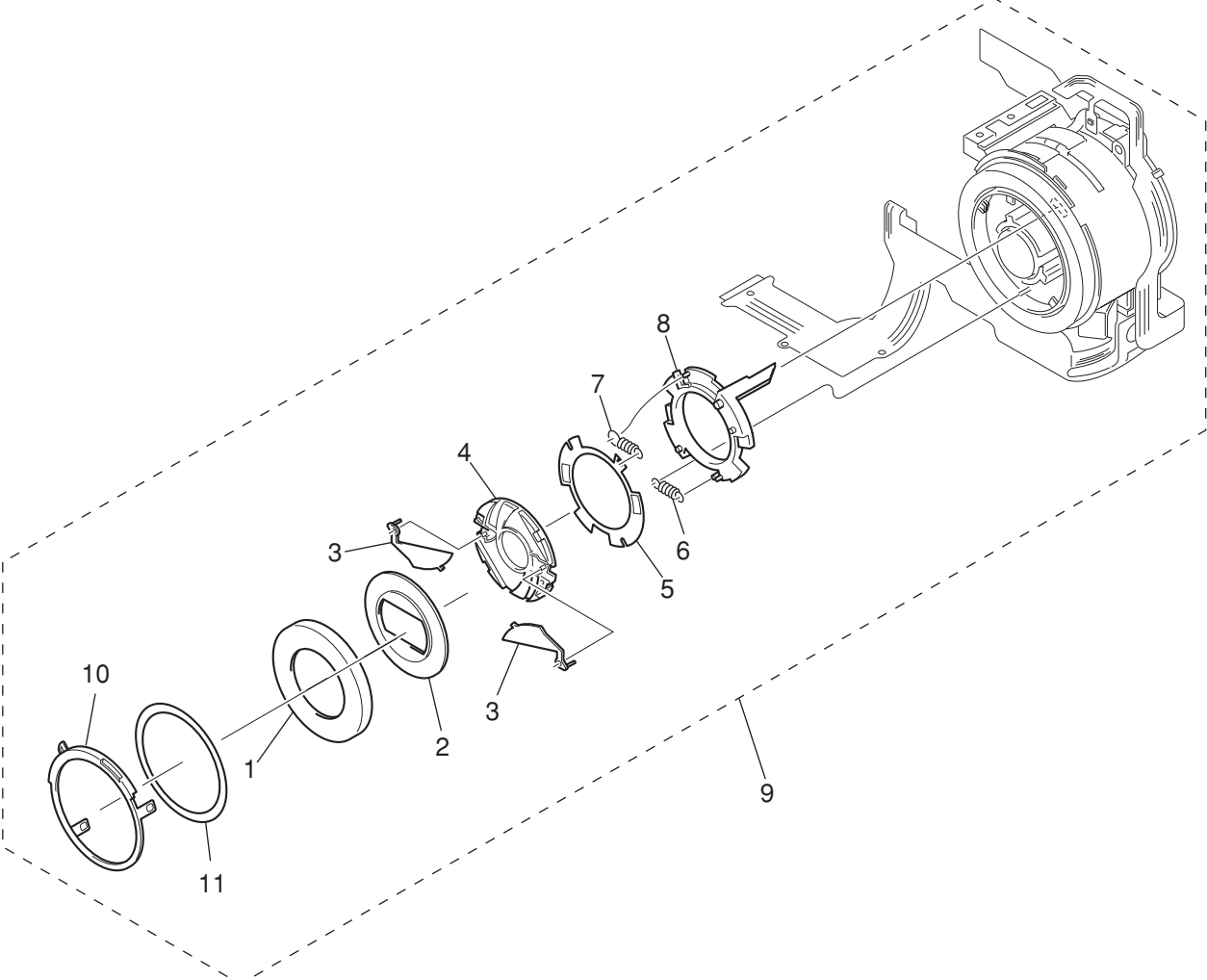

# PARTS LIST

SYMBOL	PARTS NO.	CLASS	QTY	DESCRIPTION	REMARKS
1	CD1-3033-000	B	1	CAP, BARREL1	
2	CD1-3034-010	B	1	CAP, FRONT	
3	CD1-4171-000	B	2	PLATE, BARRIER	
4	CD1-4172-000	C	1	BASE, BARRIER	
5	CD1-3042-010	C	1	PLATE, BARRIER DRIVE	
6	CS8-5204-000	C	1	SPRING, BARRIER OPEN	
7	CS8-5205-000	C	1	SPRING, BARRIER CLOSE	
8	CD1-4173-000	C	1	RING, BARRIER DRIVE	
9	CM1-2022-000	C	1	OPTICAL UNIT	
10	CD1-4169-000	C	1	CAP, BASE BARREL	
11	CD1-3036-000	C	1	SHEET, LENS BARREL	

## Accessories-1

**Wrist Strap WS-110**

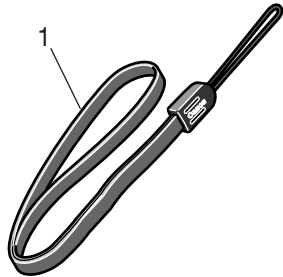

**TERMINAL COVER NB-1LH**

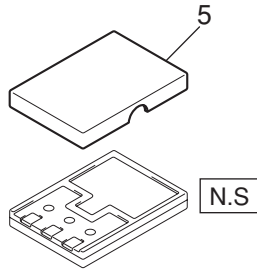

**USB Interface Cable  
IFC-200PCU**

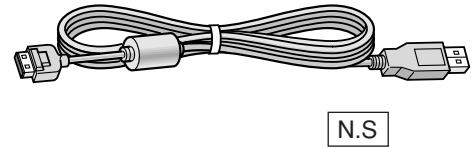

**Canon Digital Camera  
Solution Disk,  
ArcSoft Camera Suite Disk**

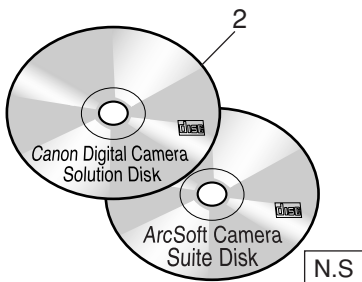

**Battery Charger  
CB-2LS/2LSE**

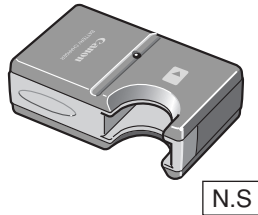

**AV Cable AVC-DC200**

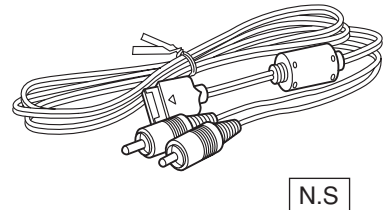

**DC Coupler DR-500**

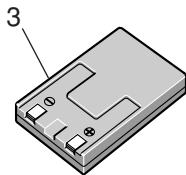

**CF Card FC-16M**

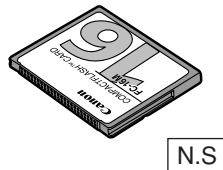

**AC Cable**

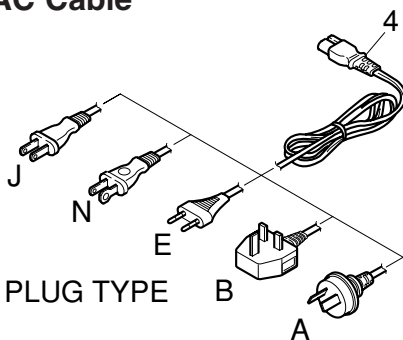

**N.S**: N.S Stand for No Stock (Product available)

## PARTS LIST

SYMBOL	PARTS NO.	CLASS	QTY	DESCRIPTION	REMARKS
1	CD1-3113-000	B	1	WRIST STRAP WS-110	
2	C84-1132-000	S	1	CD-ROM, SOLUTION VER.11 (J/E)	FOR JAPAN, ASIA, AUSTRALIA
	C84-1138-000	S	1	CD-ROM, SOLUTION VER.11 (E/F/S)	FOR USA, CANADA
3	C84-1044-000	B	1	DC COUPLER DR-500	
4	D82-0641-000	C	1	CABLE, AC (J)	FOR JAPAN
	D82-0642-000	C	1	CABLE, AC (N)	FOR USA, CANADA
	D82-0643-000	C	1	CABLE, AC (E)	FOR EUROPE, ASIA
	D82-0644-000	C	1	CABLE, AC (B)	FOR ASIA
	D82-0645-000	C	1	CABLE, AC (A)	FOR AUSTRALIA
5	CD1-4329-000	B	1	COVER, TERMINAL NB-1LH	

# Accessories-2

## Waterproof Case WP-DC 600 N.S

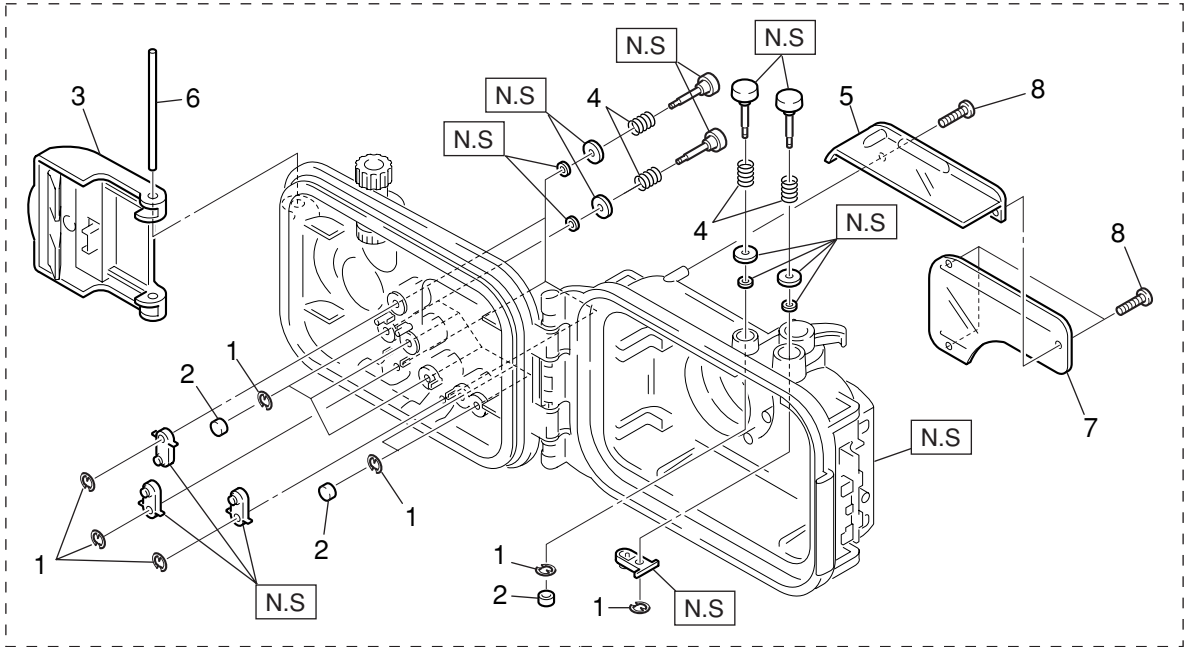

### Waterproof Seal

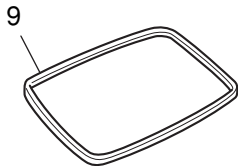

### Silicone Grease

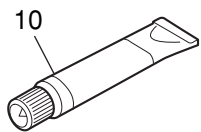

### Anti-Condensation Solution

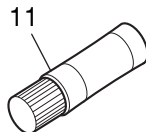

### Neck Strap

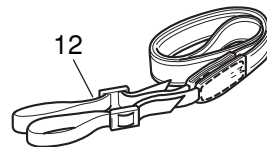

### Wrist Strap

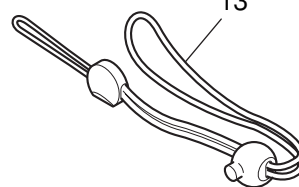

### Diffusion Plate Unit

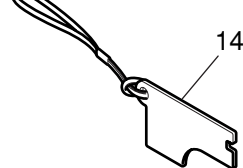

N.S: N.S Stand for No Stock (Product available)

## PARTS LIST

SYMBOL	PARTS NO.	CLASS	QTY	DESCRIPTION	REMARKS
1	CY1-6168-000	C	10	E RING	
2	CY1-6169-000	C	6	CAP, BUTTON	
3	CY1-6171-000	C	1	BUCKLE ASS'Y	
4	CY1-6167-000	C	10	SPRING, COIL	
5	CY1-6202-000	C	1	HOLDER, DIFFUSION PLATE	
6	CY1-6203-000	C	1	SHAFT, BUCKLE	
7	CY1-6201-000	C	1	PROTECTOR, DIFFUSION PLATE	
8	CY6-3210-000	C	4	SCREW	
9	CY1-6177-000	B	1	PACKING, RUBBER	
10	DY9-3029-000	C	1	GREASE, PACKING	
11	DY9-3028-000	C	1	CLEANER, ANTI-FOGGING LIQUID	
12	CY1-6099-000	B	1	STRAP, NECK	
13	CY1-6174-000	B	1	STRAP, WRIST	
14	CY1-6178-000	B	1	DIFFUSION PLATE UNIT	



# Accessories-3

## Camera User Guide

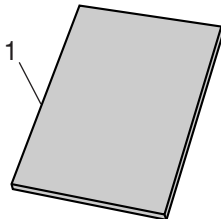

## Software Starter Guide

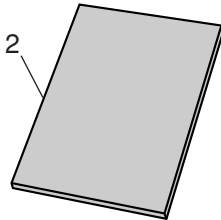

## System Map

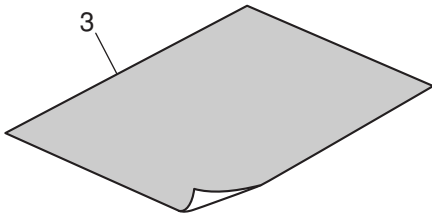

## Quick Start Guide

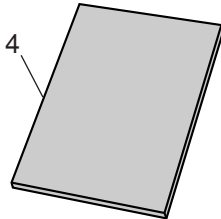

## PARTS LIST

SYMBOL	PARTS NO.	CLASS	QTY	DESCRIPTION	REMARKS
1	CDI-E072-000	S	1	I.BOOK(E) PS S230/IXUS V3	FOR USA, CANADA, ASIA, AUSTRALIA
	CDI-S062-000	S	1	I.BOOK(S) PS S230	FOR USA
	CDI-J063-000	S	1	I.BOOK(J) IXY DIGITAL 320	FOR JAPAN
	CDI-F061-000	S	1	I.BOOK(F) PS S230	FOR CANADA
2	CDI-E071-000	S	1	SOFTWARE GUIDE(E) VER.11	FOR USA, CANADA, ASIA, AUSTRALIA
	CDI-S061-000	S	1	SOFTWARE GUIDE(S) VER.11	FOR USA
	CDI-J062-000	S	1	SOFTWARE GUIDE(J) VER.11	FOR JAPAN
	CDI-F060-000	S	1	SOFTWARE GUIDE(F) VER.11	FOR CANADA
3	CDI-E073-000	S	1	SYSTEM MAP(E) PS S230/IXUS V3	FOR USA, CANADA, ASIA, AUSTRALIA
	CDI-S063-000	S	1	SYSTEM MAP(S) PS S230	FOR USA
	CDI-J064-000	S	1	SYSTEM MAP(J) IXY DIGITAL 320	FOR JAPAN
	CDI-F062-000	S	1	SYSTEM MAP(F) PS S230	FOR CANADA
4	CDI-E074-000	S	1	QUICK START GUIDE(E)	FOR USA, CANADA, ASIA, AUSTRALIA
	CDI-S064-000	S	1	QUICK START GUIDE(S)	FOR USA
	CDI-J065-000	S	1	QUICK START GUIDE(J)	FOR JAPAN
	CDI-F063-000	S	1	QUICK START GUIDE(F)	FOR CANADA

# Service Tools

**DIA BOND NO.1663G BLACK**

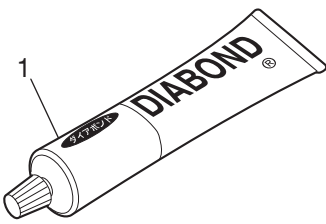

**W-10 Filter**

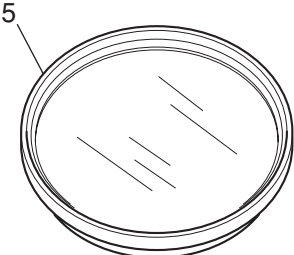

**FL-W Filter**

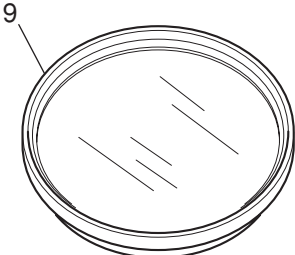

**Adhesive Tape SONY T4000**

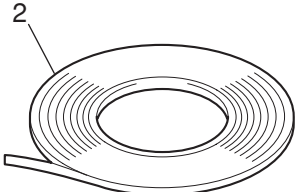

**18% Gray Chart**

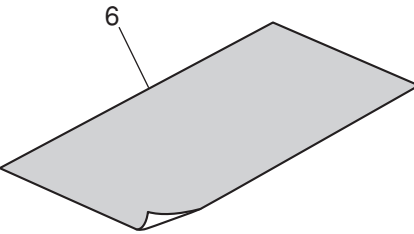

**Color Viewer (5600° K)**

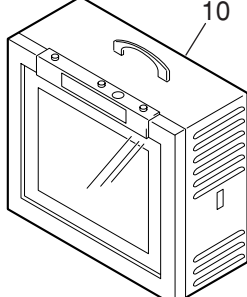

**Adhesive Tape 3M NO.56**

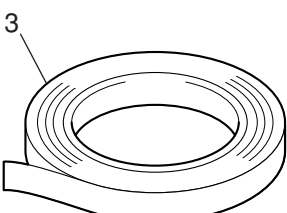

**HANARL FL-778**

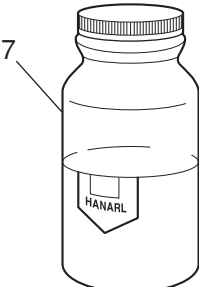

**Standard Color Bar Chart**

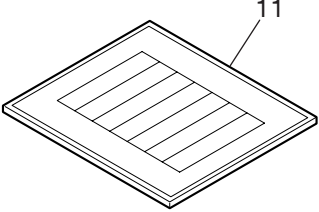

**C-12 Filter**

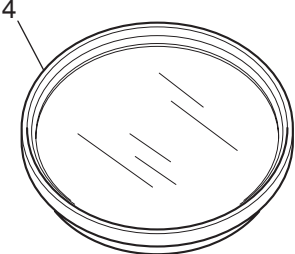

**SERVICE MANUAL CD-ROM**

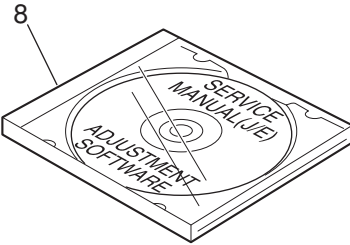

## PARTS LIST

SYMBOL	PARTS NO.	CLASS	QTY	DESCRIPTION	REMARKS
1	CY9-8129-000	Y	1	BOND, DIA BOND NO.1663G BLACK	
2	CY4-6012-000	Y	1	ADHESIVE TAPE, SONY T4000	6mm × 50m roll
3	CY4-6018-000	Y	1	ADHESIVE TAPE, 3M NO.56	15mm × 66m roll
4	DY9-2029-000	Y	1	FILTER, C-12	
5	CY9-1543-000	Y	1	FILTER, W-10	
6	CY4-6016-000	Y	1	CHART, 18% GRAY	
7	DY9-3026-010	Y	1	LUBE, HANARL FL-778, OIL	
8	CY8-4380-031	Y	1	CD-ROM, SERVICE MANUAL (J/E)	
9	CY9-1550-000	Y	1	FILTER, FL-W	
10	DY9-2039-100	Y	1	COLOR VIEWER 5600K	
11	DY9-2002-000	Y	1	COLOR BAR CHART	

# CHAPTER 5. DIAGRAMS

## CONTENTS

1. INTERCONNECTION DIAGRAM
2. BLOCK DIAGRAMS
  - 2-1. OVERALL
  - 2-2. MAIN PCB ASS'Y (1/3)
  - 2-3. MAIN PCB ASS'Y (2/3)
  - 2-4. MAIN PCB ASS'Y (3/3)
  - 2-5. FLASH/DC UNIT
  - 2-6. Abbreviation in Block Diagrams
3. P.C.B. DIAGRAMS
  - 3-1. MAIN PCB ASS'Y
  - 3-2. FLASH/DC UNIT
  - 3-3. OPTICAL UNIT
  - 3-4. BATTERY BOX UNIT
  - 3-5. CF UNIT
  - 3-6. OPERATION KEY UNIT



# 1. INTERCONNECTION DIAGRAM

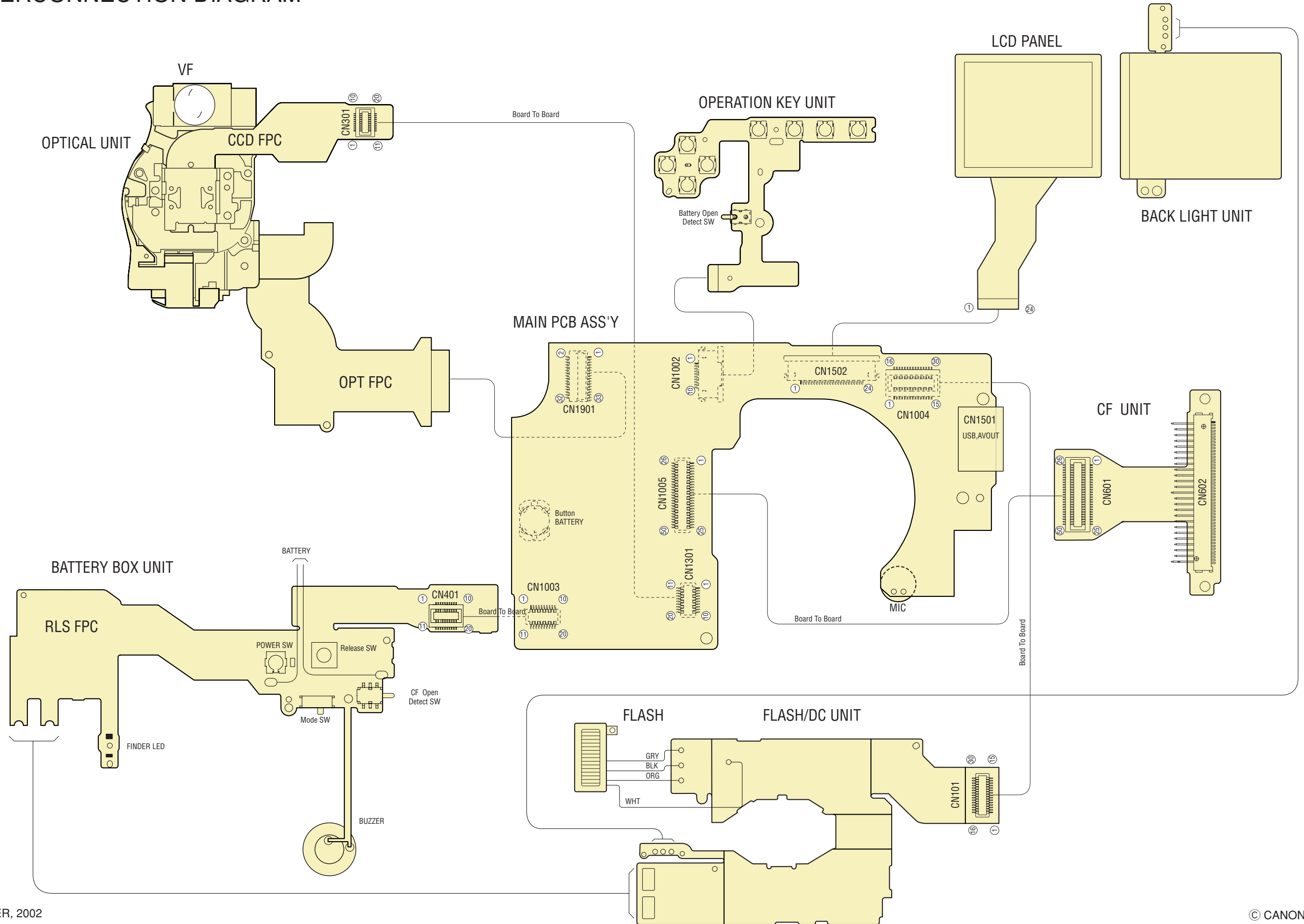

# CONNECTORS

## MAIN PCB ASS'Y

CN1002	
1	SCAN
2	BTOP
3	UP
4	LEFT
5	LED_POWERAN
6	LED_POWER
7	DOWN
8	RIGHT
9	EXP/WB/ERASE
10	DISP
11	MINUS
12	SET
13	M_GND
14	M_GND
CN1003	
1	M_GND
2	VCC1
3	LED_GREEN
4	LED_ORANGE
5	LED_MACRO
6	POWER
7	M_GND
8	C_GND
9	C_GND
10	MODE1
11	MODE0
12	SCAN
13	SW1
14	SW2
15	VBATTEP
16	BUZZER
17	CFOP
18	TELE
19	WIDE
20	M_GND

CN1004	
1	Not Connected
2	VEE2
3	VDD3
4	E1PLAT
5	VCC1L
6	VCC1L
7	VDD2
8	VBATT
9	VBATT
10	VCC1SD
11	VCC1SD
12	EFCHG
13	LED_BL
14	STSP
15	VCHGLVL
16	C_GND
17	C_GND
18	C_GND
19	VCC2RE
20	E3LAT
21	VCC2AFE
22	E2LAT
23	VBATT
24	VBATT
25	VCC1A
26	VCC1
27	VCC1
28	M_GND
29	M_GND
30	M_GND

CN1005	
1	/CE1
2	/CE2
3	A10
4	/VS1
5	/OE
6	/IORD
7	A09
8	/IOWR
9	A08
10	/WE
11	A07
12	IREQ
13	VCC1
14	VCC1
15	A06
16	Not Connected
17	A05
18	/VS2
19	A04
20	RESET
21	A03
22	/WAIT
23	A02
24	Not Connected
25	A01
26	C_GND
27	/CD1
28	D03
29	D11
30	D04
31	D12
32	D05
33	D13
34	D06
35	D14
36	D07
37	D15
38	/REG
39	A00
40	Not Connected
41	D00
42	Not Connected
43	D01
44	D08
45	D02
46	D09
47	/IOIS16
48	D10
49	/CD2
50	C_GND

CN1301	
1	C_GND
2	C_GND
3	C_GND
4	RG
5	V1
6	V3A
7	CSUB
8	V4
9	H1
10	H2
11	GND
12	VOUT
13	VDD
14	V2
15	SUB
16	V3B
17	VL
18	V5A
19	V5B
20	V6
CN1501	
1	UV_GND
2	Not Connected
3	Not Connected
4	Not Connected
5	Not Connected
6	VBUS
7	VIDEO
8	VC_DET
9	D-
10	D+
11	AUDIO
12	UV_GND
CN1502	
1	Not Connected
2	RGT
3	BLUE
4	RED
5	GREEN
6	PSIG
7	HCK1
8	HCK2
9	CEXT/REXT
10	Not Connected
11	REF
12	HST
13	WIDE
14	Not Connected
15	VSSG
16	VDDG
17	VSS
18	VDD
19	DWN
20	EN
21	VCK
22	VST
23	COM
24	Not Connected

CN1901	
1	SLNT_AN
2	SLNT_DET0
3	SLNTZM_COM
4	SLNTZM_COM
5	ZMPI_AN
6	ZMPO0
7	SLNT_AN
8	SLNT_DET1
9	ZMO+
10	ZMO+
11	ZMO-
12	ZMO-
13	AFLEDAN
14	AFLEDK
15	ZMPI_AN
16	ZM_RST
17	SH+ AFA+
18	SH+ AFA+
19	SH-
20	SH-
21	IR-
22	IR-
23	IR+ AFB-
24	IR+ AFB-
25	AFB+
26	AFB+
27	AFA-
28	AFA-
29	ZMAFPI_COM
30	ZMPI_AN
31	ZMPO1
32	AFPI_AN
33	AFRST

## OPTICAL UNIT

CN301	
1	GND
2	GND
3	GND
4	RG
5	V1
6	V3A
7	CUSB
8	V4
9	H1
10	H2
11	GND
12	VOUT
13	VDD
14	V2
15	SUB
16	V3B
17	VL
18	V5A
19	V5B
20	V6

## BATTERY BOX UNIT

CN401	
1	M_GND
2	VCC1
3	LED_GREEN
4	LED_ORANGE
5	LED_MACRO
6	POWER
7	M_GND
8	C_GND
9	C_GND
10	MODE1
11	MODE0
12	SCAN
13	SW1
14	SW2
15	VBATTEP
16	BUZZER
17	CFOP
18	TELE
19	WIDE
20	M_GND

## CF UNIT

CN601	
1	/CE1
2	/CE2
3	A10
4	/VS1
5	/OE
6	/IORD
7	A09
8	/IOWR
9	A08
10	/WE
11	A07
12	IREQ
13	VCC1
14	VCC1
15	A06
16	Not connected
17	A05
18	/VS2
19	A04
20	RESET
21	A03
22	/WAIT
23	A02
24	Not connected
25	A01
26	C_GND
27	/CD1
28	D03
29	D11
30	D04
31	D12
32	D05
33	D13
34	D06
35	D14
36	D07
37	D15
38	/REG
39	A00
40	Not connected
41	D00
42	Not connected
43	D01
44	D08
45	D02
46	D09
47	/IOIS16
48	D10
49	/CD2
50	C_GND

CN602	
1	GND
2	D03
3	D04
4	D05
5	D06
6	D07
7	/CE1
8	A10
9	/OE
10	A09
11	A08
12	A07
13	VCC
14	A06
15	A05
16	A04
17	A03
18	A02
19	A01
20	A00
21	D00
22	D01
23	D02
24	/IOIS16
25	/CD2
26	/CD1
27	D11
28	D12
29	D13
30	D14
31	D15
32	/CE2
33	/VS1
34	/IORD
35	/IOWR
36	/WE
37	IREQ
38	VCC
39	Not connected
40	/VS2
41	RESET
42	/WAIT
43	Not connected
44	/REG
45	Not connected
46	Not connected
47	D08
48	D09
49	D10
50	GND

## FLASH/DC UNIT

CN101	
1	Not Connected
2	VEE2
3	VDD3
4	E1PLAT
5	VCC1L
6	VCC1L
7	VDD2
8	VBATT
9	VBATT
10	VCC1SD
11	VCC1SD
12	EFCHG
13	LED_BL
14	STSP
15	VCHGLVL
16	C_GND
17	C_GND
18	C_GND
19	VCC2RE
20	E3LAT
21	VCC2AFE
22	E2LAT
23	VBATT
24	VBATT
25	VCC1A
26	VCC1
27	VCC1
28	M_GND
29	M_GND
30	M_GND



## 2. BLOCK DIAGRAMS

### 2.1 OVERALL

- DATA COMMUNICATION
- ANALOG IMAGE SIGNAL
- ANALOG AUDIO SIGNAL

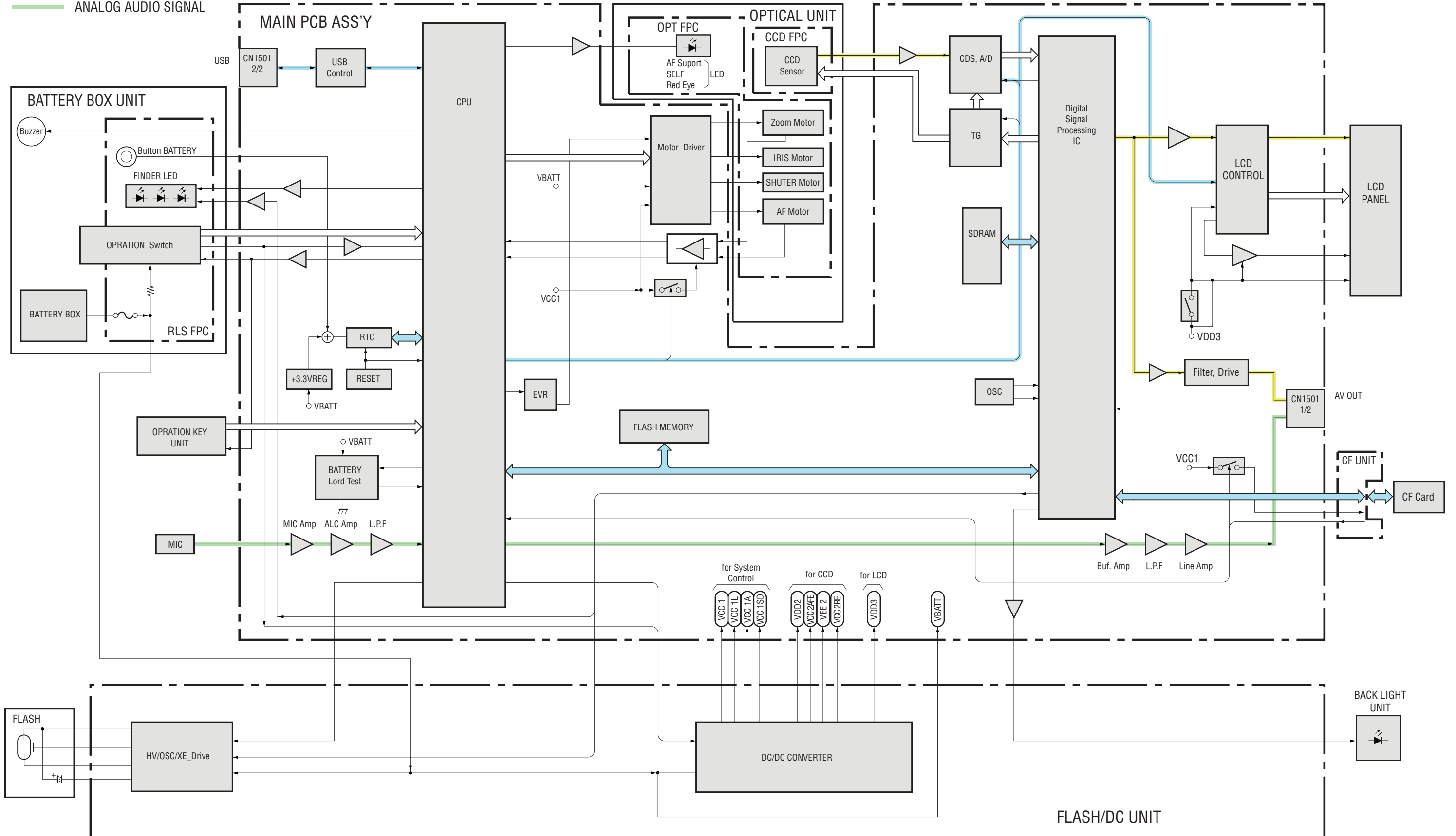





## 2.4 MAIN PCB ASS'Y (3/3)

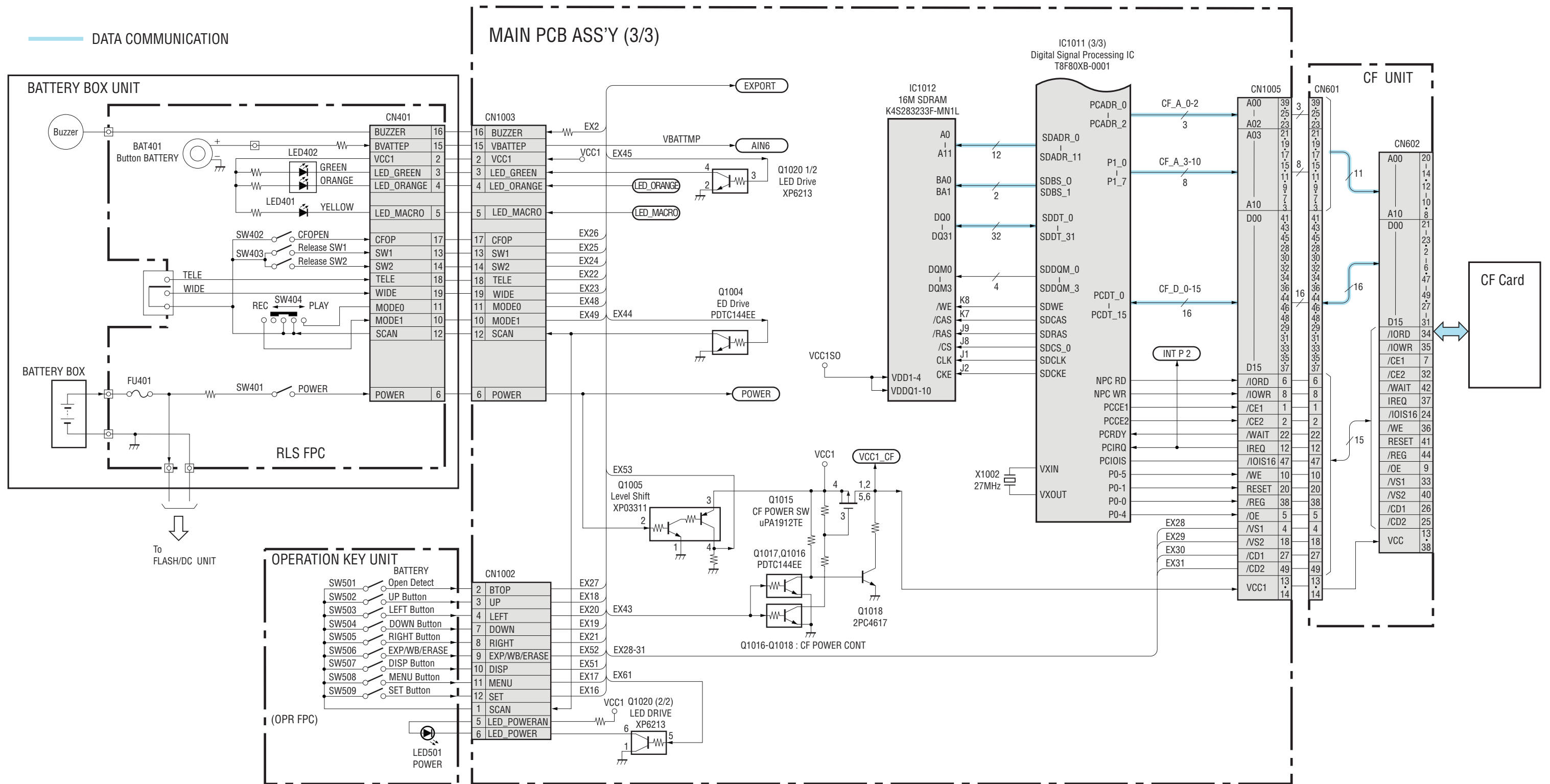

## 2.5 FLASH/DC UNIT

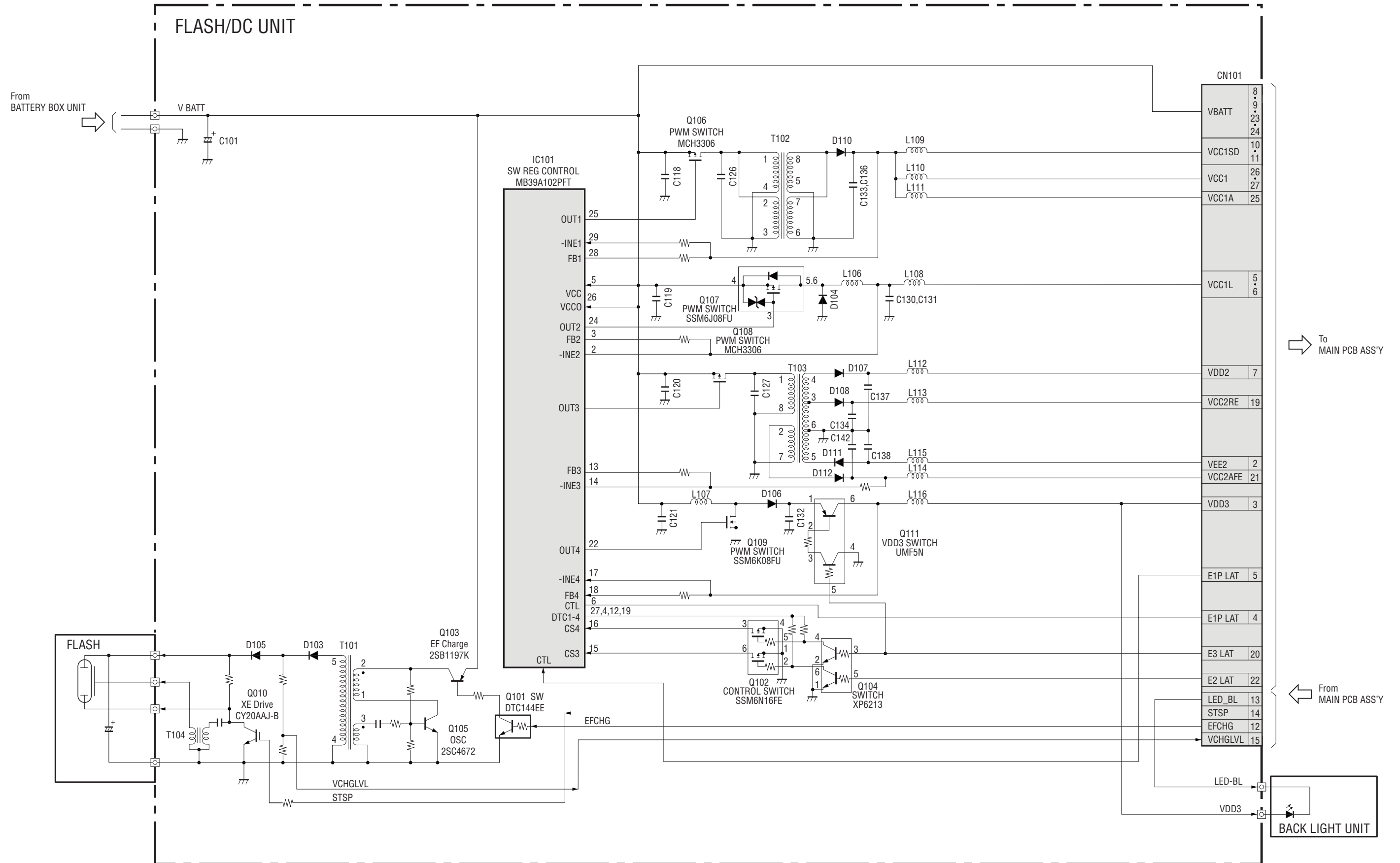

## 2.6 Abbreviation in Block Diagrams

Abbreviation	Nominal name	Description
ADC	Analog-to-Digital (A/D) Converter	
AE	Automatic Exposure control	
AF	Automatic Focussing control	
AND	Logic AND circuit	
R-Y/B-Y		Color difference signals of TV system
BPF	Band-Pass Filter	
BUFFER	Buffer circuit	
C	Chrominance signal	Color component signal of TV system
CCD	Charge-Coupled Device	CCD imager
CDS	Correlated Double Sampling system	
COMP.VIDEO	Composite video signal	
COMPARATOR	Voltage comparator	
CPU	Central Processing Unit	
DAC	Digital-to-Analog (D/A) Converter	
DRAM	Dynamic Random Access Memory	Memory with which read and write are freely possible.
DSP	Digital Signal Processing	Typically DSP device
EEPROM	Electrically Erasable PROM	PROM that is electrically erasable.
EVF	Electronic View Finder	
FET	Field Effect Transistor	
FLASH MEMORY		Non-volatile memory with which write and read are freely possible.
HPF	High-Pass Filter	
I/F	InterFace	The circuit that interconnects 2 devices or circuits.
IGBT	Insulated Gate Bipolar Transistor	Conductivity-modulation type FET transistor
INV.	Logic Inverter circuit	
IR	InfraRed ray	
IRIS	Iris	
LCD	Liquid Crystal Device	Typically LCD display
LED	Light Emitting Diode	Typically LED display
LPF	Low-Pass Filter	
NTSC	National Television System Committees	NTSC color TV system developed in USA
OP Amp	OPerational Amplifier	
OR	Logic OR circuit	
OSC	OSCillator	
PAL	Phase Alternating by Line	PAL color TV system developed in Germany
PLL	Phase Locked Loop	
PROM	Programmable Read Only Memory	Non-volatile memory in which program can be written.
PWM	Pulse Width Modulation	
REG.	REGulated power supply	
RTC	Real Time Clock	Reference clock oscillator
SDRAM	Synchronous Dynamic RAM	DRAM whose bus interface is synchronous.
SECAM	SEquential Colour À Mémoire	SECAM color TV system developed in France
SW REG	SWitching REGulator	Switching type regulated power supply device
TG	Timing Generator	
USB	Universal Serial Bus	USB type serial data communication system
VCO	Voltage Controlled Oscillator	
VCXO	Voltage Controlled X'tal Oscillator	
XE	Xenon Tube	
Y	Y-signal	Luminance component signal of TV system

# 3. P.C.B. DIAGRAMS

## 3.1 MAIN PCB ASS'Y

MAIN PCB ASS'Y (SOLDERING SIDE)

MAIN PCB ASS'Y (COMPONENT SIDE)

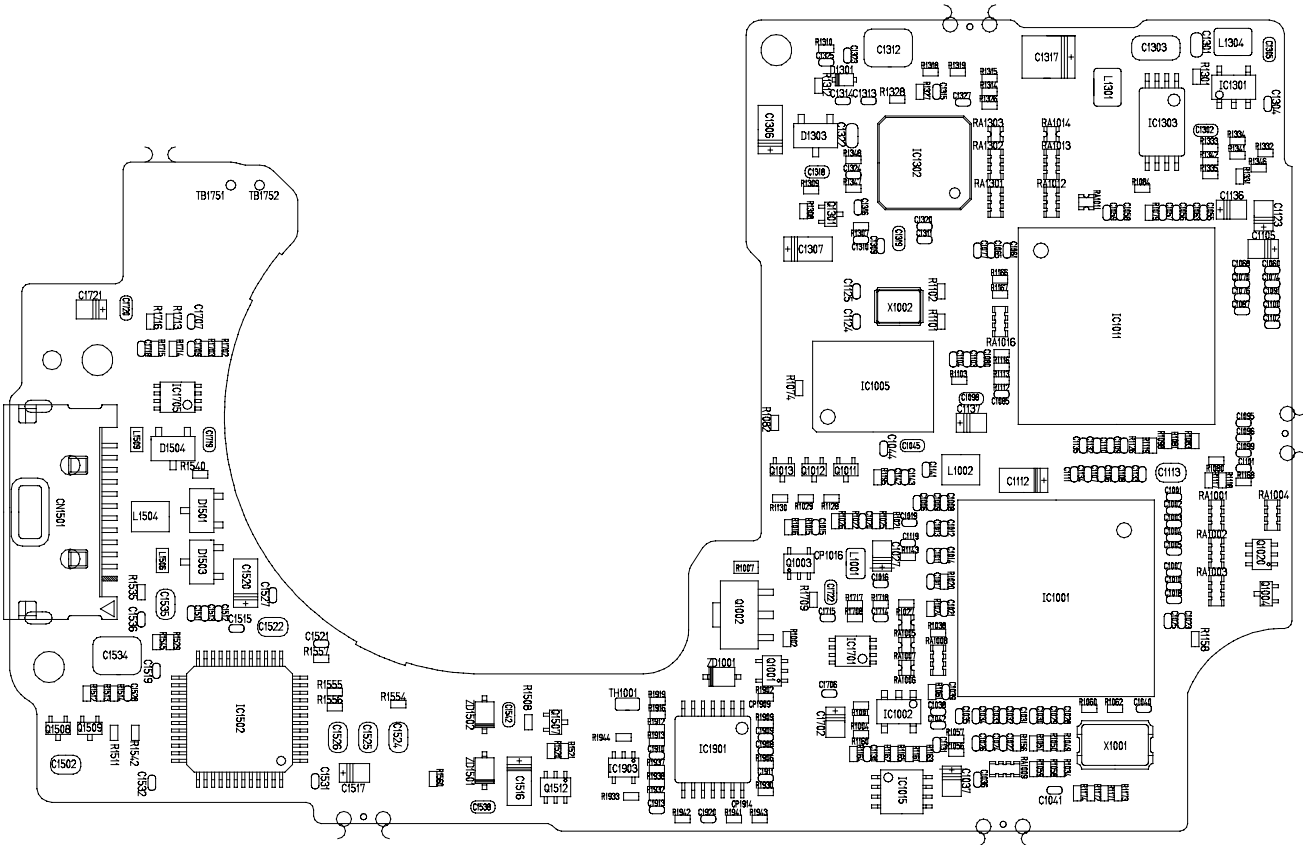
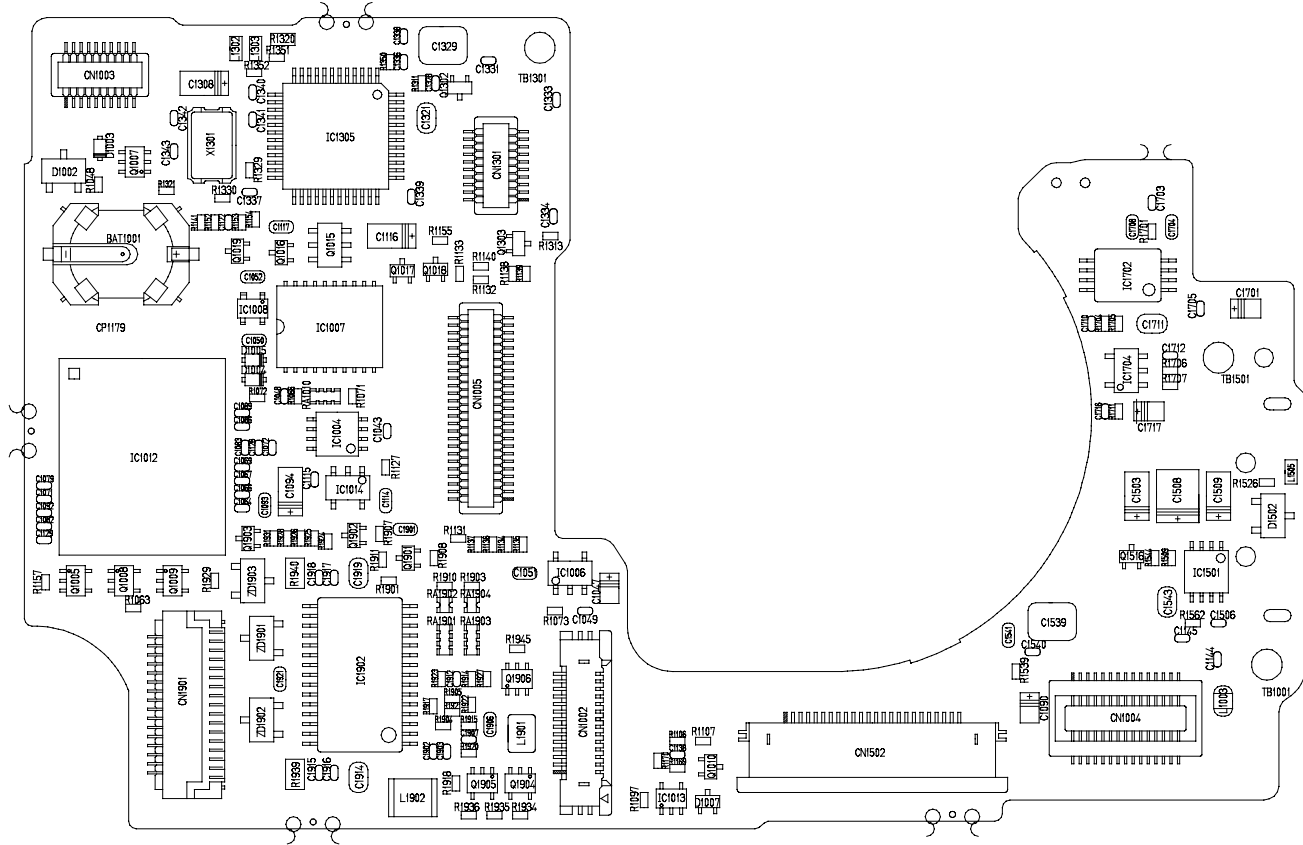

### 3.2 FLASH/DC UNIT

#### FLASH/DC UNIT (SOLDERING SIDE)

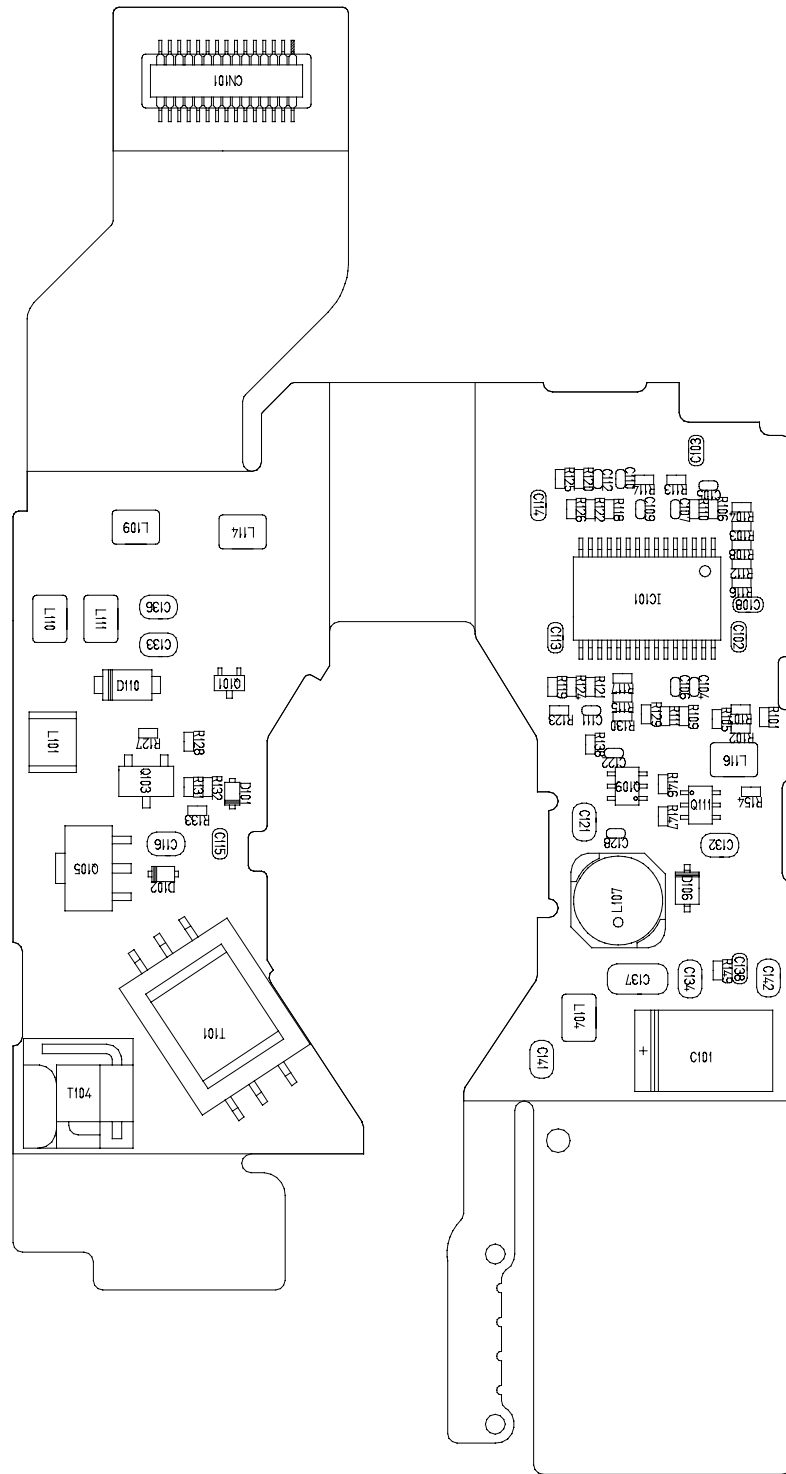

#### FLASH/DC UNIT (COMPONENT SIDE)

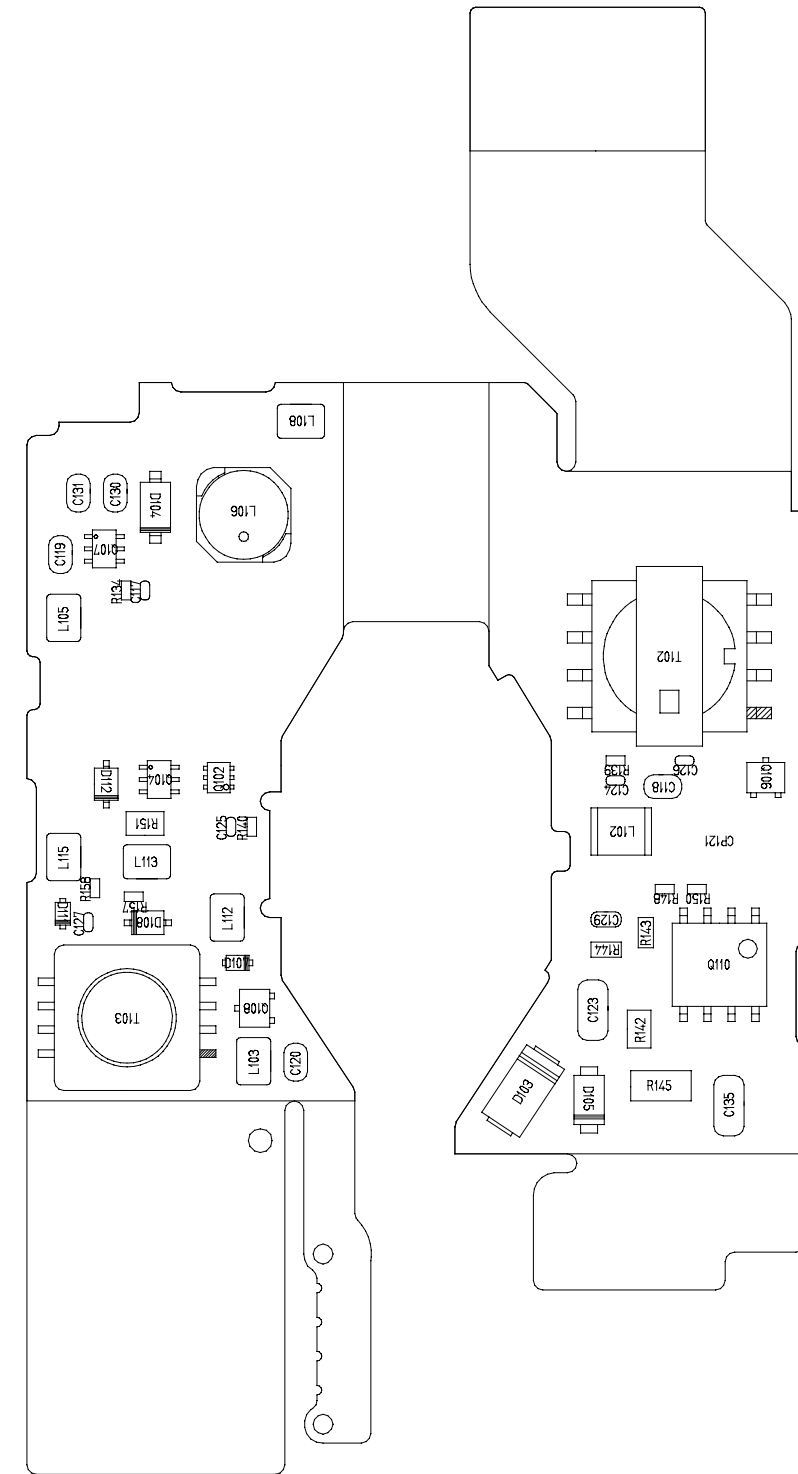



### 3.3 OPTICAL UNIT

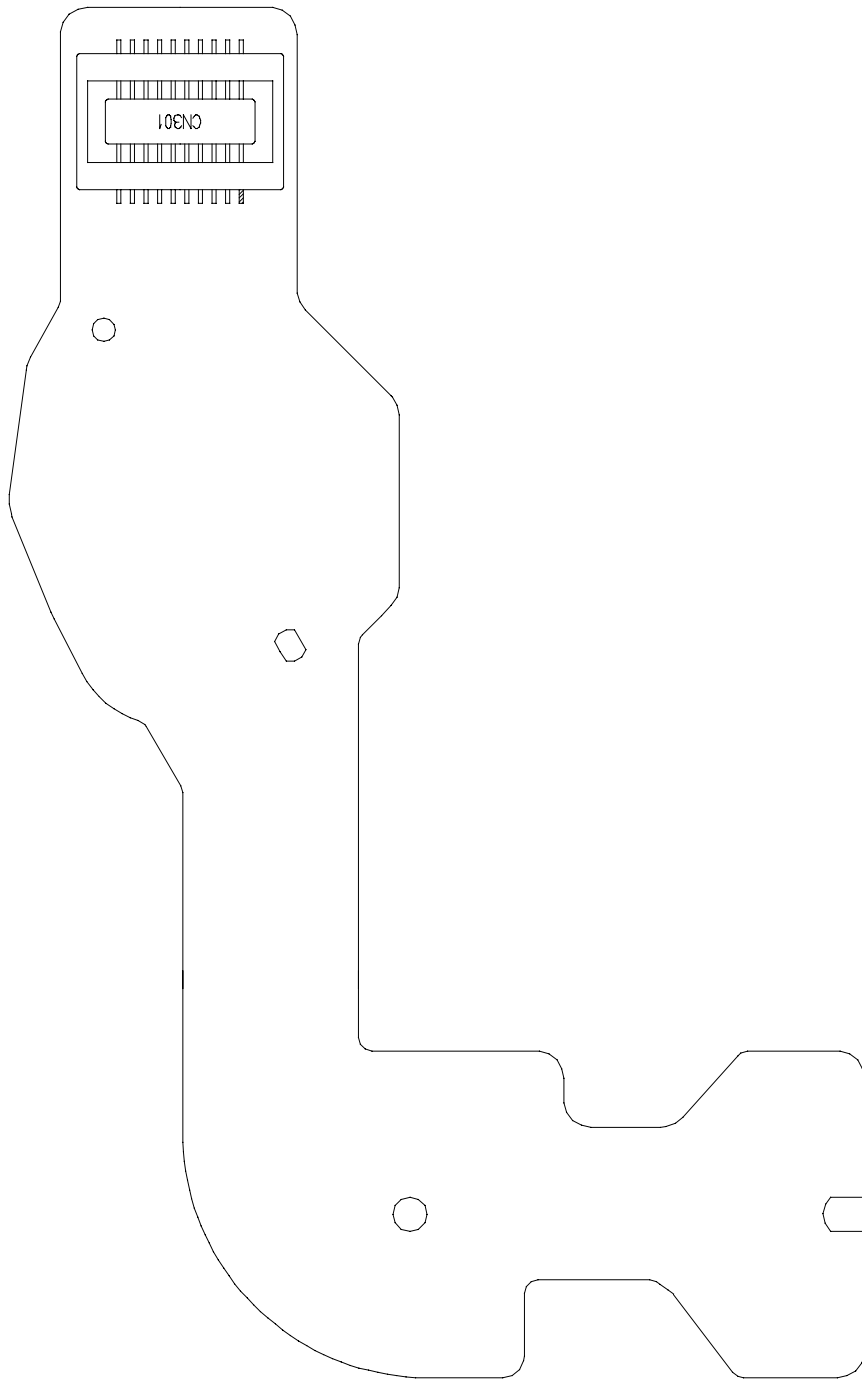

### 3.4 BATTERY BOX UNIT

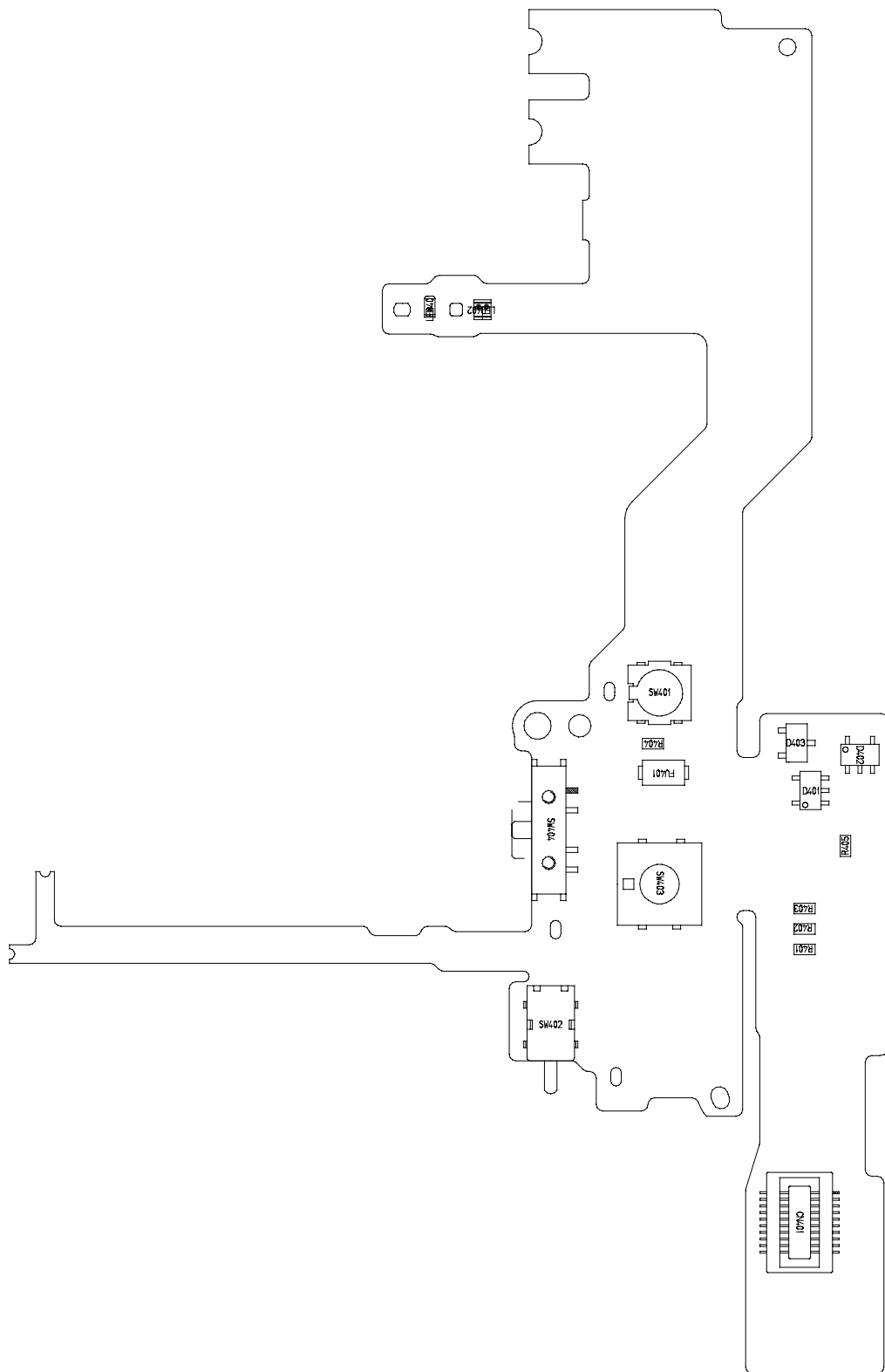

## 3.5 CF UNIT

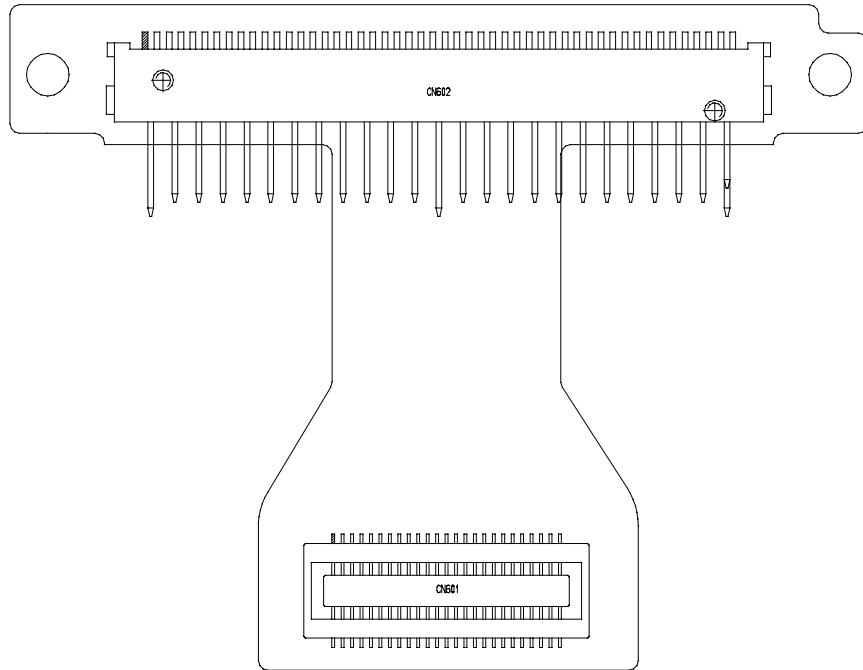

## 3.6 OPERATION KEY UNIT

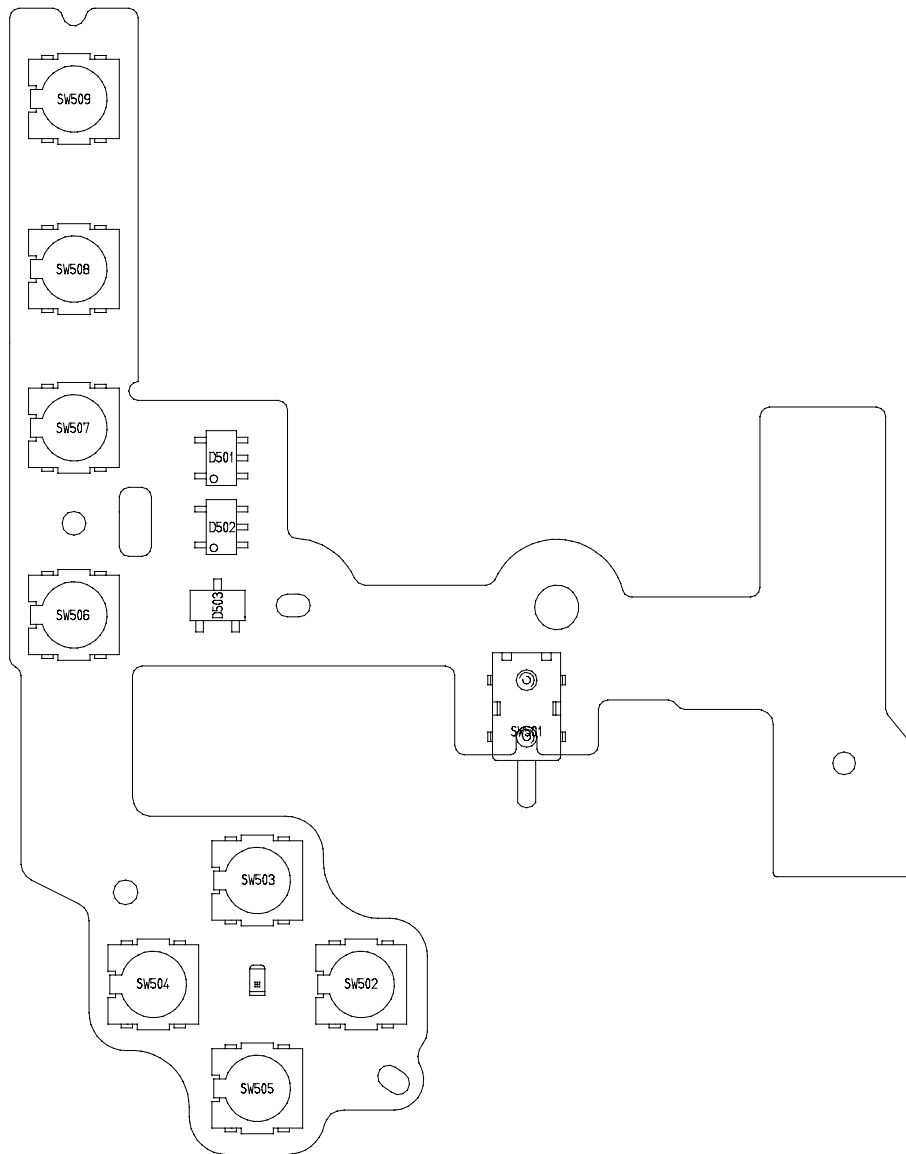

# How to print out the Zoom/AF Chart

The large materials such as “Zoom/AF Chart” that occupy a page of large size, can be divided into several smaller pages using “Graphic Select Tool” for printing the entire page.

## < Procedures >

1. Select “ Text Select Tool” from the Command Bar and keep pressing it.

Then, select the “ Graphic Select Tool”.



2. Select the desired portion to print. (Drag the cursor on desired area.)
3. Click “Print” of the Menu Bar. Check “Selected Thumbnails/Graphic”, then start printing.  
When you check “Fit to Page”, the date can be reduced or enlarged of its printing size so that the printing size fits the size of paper.\*
4. To cancel the printing area, click an arbitrary position on the display.

## \* Remarks

The “Zoom/AF Chart” of the Service Manual that is saved in this CD-ROM, has the colored markings in colors so that the entire page can be divided into print papers (legal-size x 4 pages, A3 size x 3 pages). Operate as follows.

Select “Graphic Select Tool”. Select the 2 markings having the same color to select the first printing area. Press “Print” to print the first printing area. Perform the above steps 2 and 3. Select another 2 markings having the second color to select the second printing area. Press “Print” to print the second printing area. Repeat this procedure until the all pages are printed.

<Legal-size>

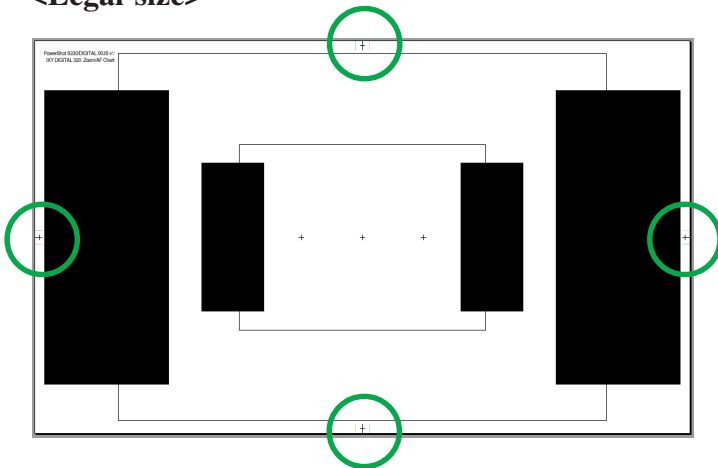

<A3 size>

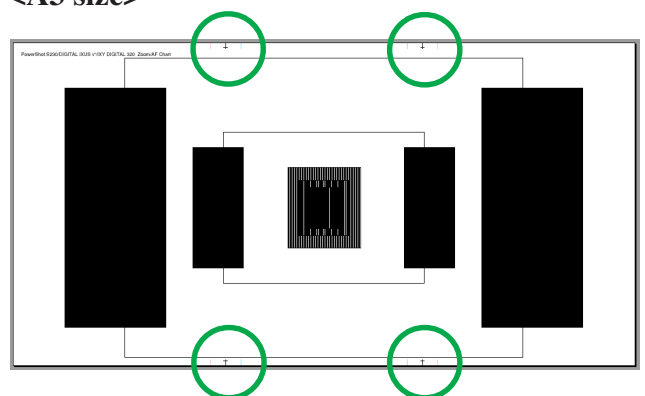

: Markings

PowerShot S230/DIGITAL IXUS v3/  
IXY DIGITAL 320 Zoom/AF Chart

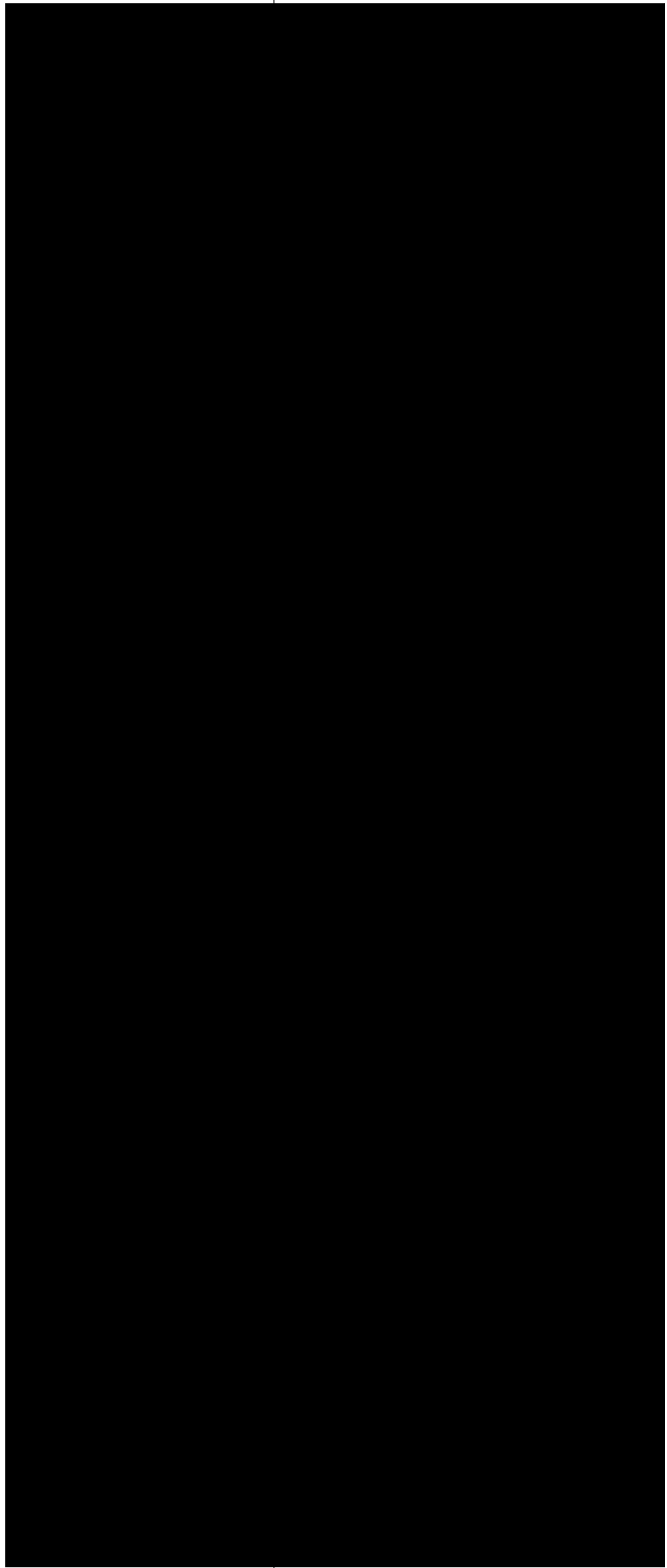
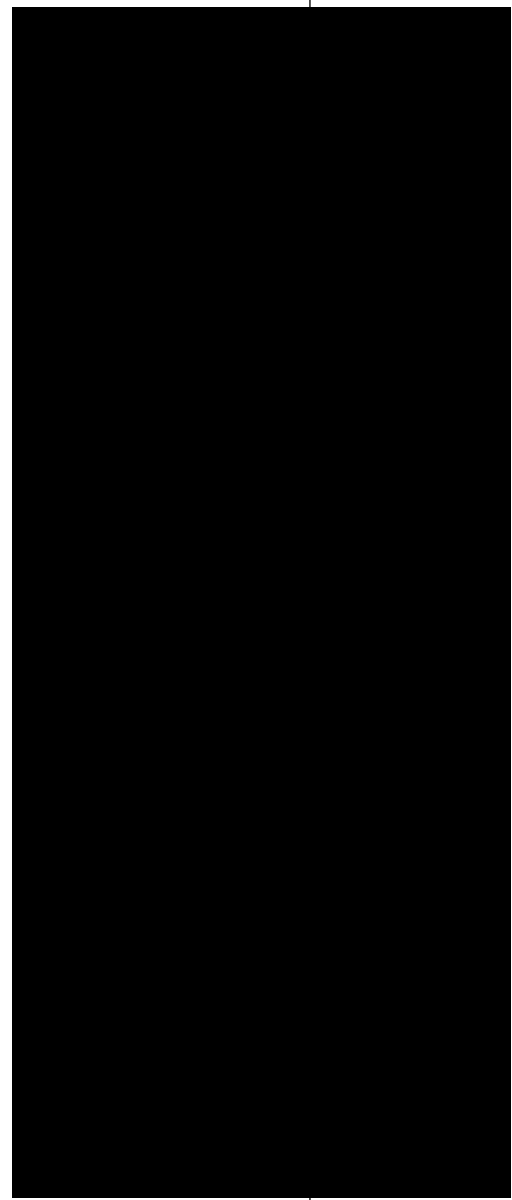
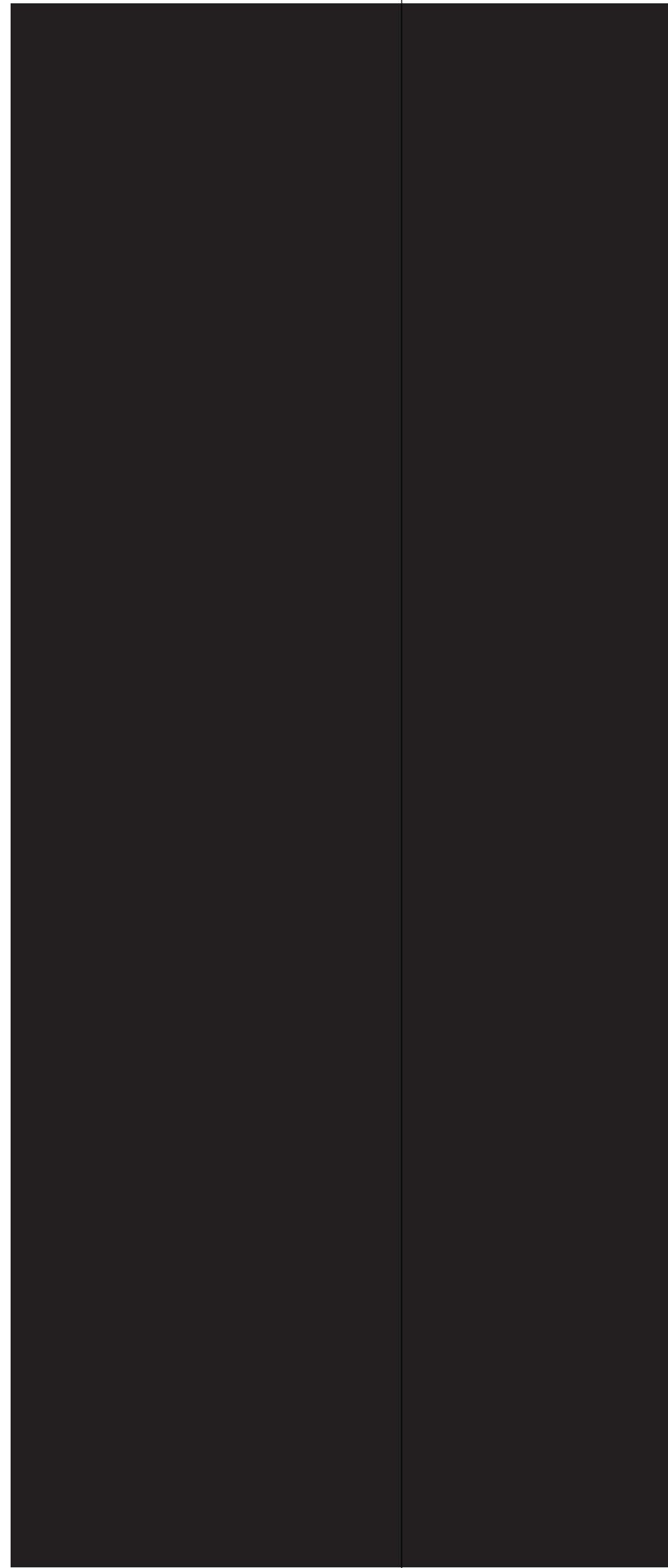

+

+

+

+

+

+

+

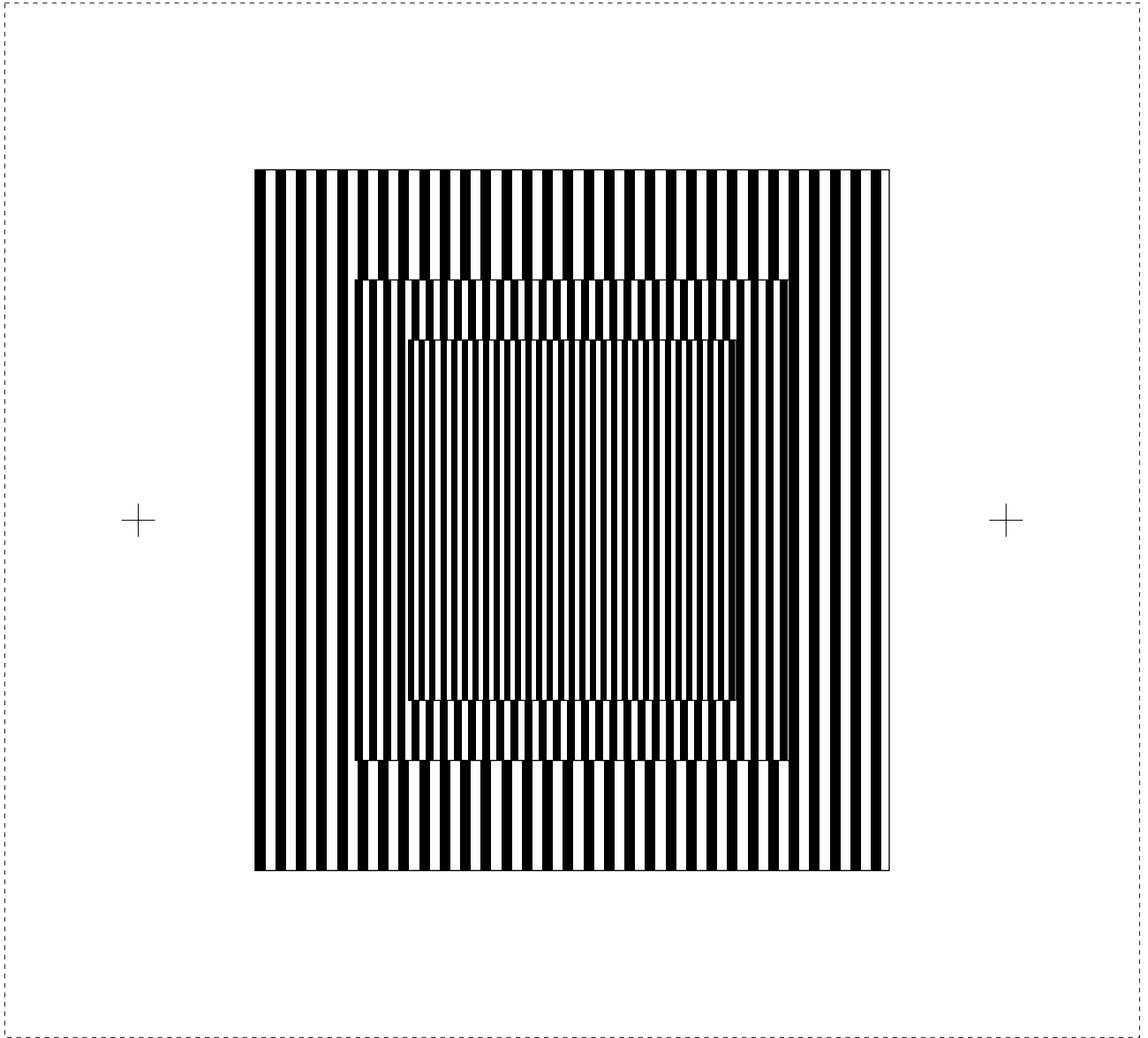

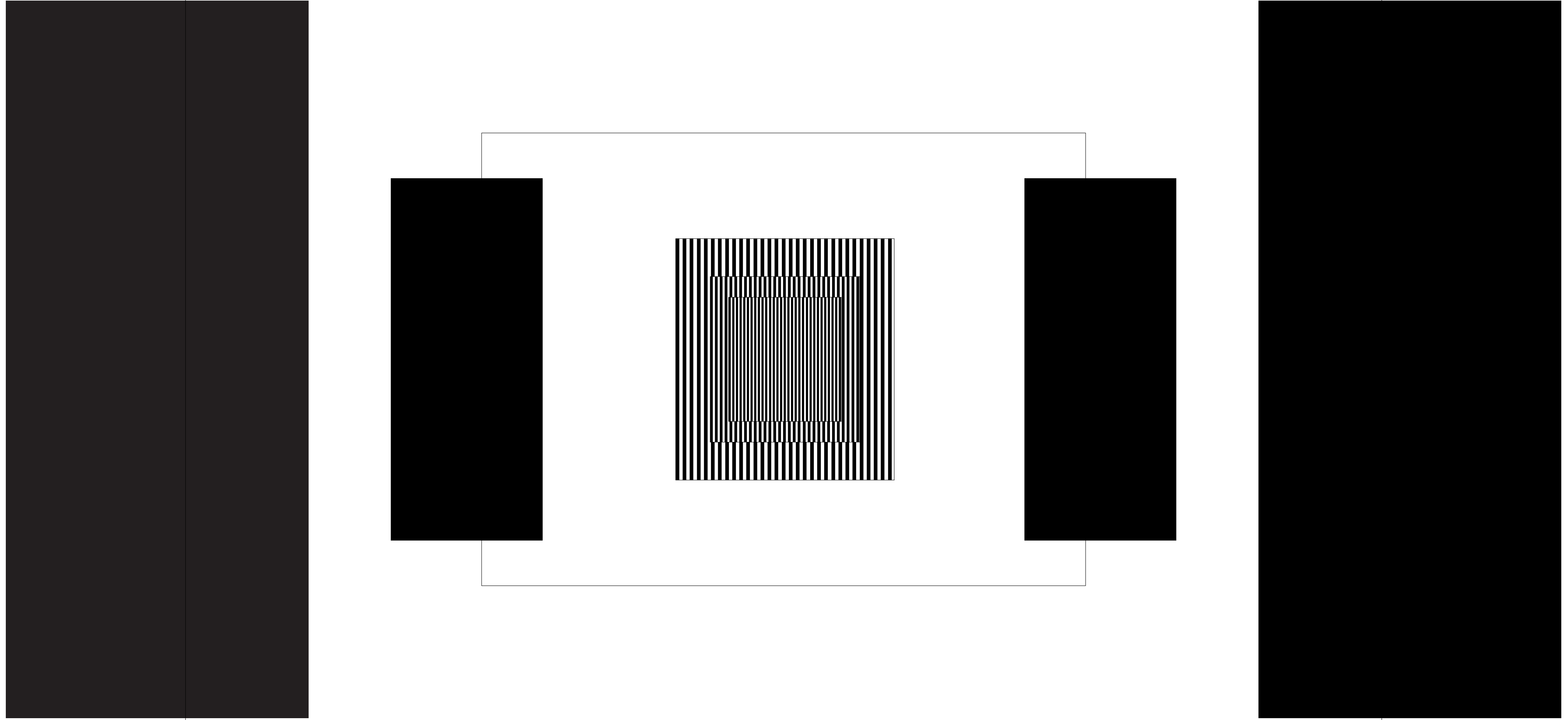



# Dimensions

