

# STILL CAPTURE

Canon professional tools for still image capture are extraordinary and comprehensive, comprising a system of digital photography that puts unparalleled imaging power in the hands of photographers. This is why professionals choose to rely on Canon for their still images. Wherever and whenever, Canon digital SLR cameras work brilliantly, so that the photographer can concentrate on the image at hand. State-of-the-art sensors, the unrivaled DIGIC Image Processor, a tremendous range of lenses perfect for any shooting situation, sophisticated lighting solutions and effortless wireless transmission make complex operations simple and intuitive. Innovations enabling low-light shooting, discreet operation, plus water and dust resistance for reliable performance under the most challenging conditions make Canon the professional's camera of choice. Canon digital cameras can go more places, do more things and give the pro more opportunities to create masterpieces.

<b>EOS-1Ds Mark III</b> .....	8
LARGE PRODUCT – <i>Gil Smith</i> .....	10
LANDSCAPE – <i>Vincent Isola</i> .....	14
SMALL PRODUCT – <i>Michel Tcherevkoff</i> .....	18
ARCHITECTURE – <i>Norman McGrath</i> .....	20
ASTRONOMY – <i>Jennifer Wu</i> .....	22
<b>EOS-1D Mark IV</b> .....	24
WILDLIFE – <i>Arthur Morris</i> .....	26
SPORTS – <i>Peter Read Miller</i> .....	30
PHOTOJOURNALISM – <i>James Nachtwey</i> .....	32
WEDDING/PORTRAIT – <i>Charles Maring</i> .....	34
WEDDING/PORTRAIT – <i>Sandy Puc</i> .....	36
<b>EOS 5D Mark II</b> .....	38
WEDDING – <i>Clay Blackmore</i> .....	40
DOCUMENTARY – <i>Joachim Ladefoged</i> .....	44
NATURE – <i>George Lepp</i> .....	46
CELEBRITY – <i>Greg Gorman</i> .....	48
ADVERTISING – <i>Tyler Stableford</i> .....	50
<b>EOS 7D</b> .....	52
DOCUMENTARY – <i>Lauren Greenfield</i> .....	54
WEDDING/PORTRAIT – <i>Michele Celentano</i> .....	58
WEDDING/PORTRAIT – <i>Stillmotion</i> .....	60
BEAUTY – <i>Stephen Eastwood</i> .....	62
CORPORATE/INDUSTRIAL – <i>Gregory Heisler</i> .....	64
PHOTOJOURNALISM – <i>Christopher Morris</i> .....	66
<b>EOS 60D</b> .....	68
WEDDING – <i>Hanson Fong</i> .....	70
TRAVEL – <i>Lewis Kemper</i> .....	74
<b>Still Capture Technology</b> .....	76
<b>PowerShot Digital Cameras</b>	
PowerShot Technology .....	84
PowerShot G12 / PowerShot S95 .....	85
<b>EF Lenses</b> .....	86
<b>Speedlites</b> .....	90
<b>Wireless Connectivity</b> .....	92

# EOS-1Ds

## Mark III

### *The Featured Professionals*

#### LARGE PRODUCT



**Gil Smith**

Explorer of Light

#### The Stuff of Dreams

Gil Smith is an internationally recognized advertising photographer specializing in high-action automotive and sports-industry images. An innovator in live and simulated-action photography, he has created dramatic campaigns for high-visibility American, European, and Japanese auto manufacturers and sports-oriented clients. Smith depends on the “big picture” capabilities of Canon EOS DSLRs, which give him the pixel count and quality he needs to create the bold images of dreams.

#### LANDSCAPE



**Vincent Isola**

Explorer of Light

#### Detail and Tonality

Vincent Isola has won numerous awards for his work, and teaches digital photography, printing and lighting techniques to photographers throughout the country. His work and articles have been featured in many prestigious publications, including *Architectural Digest*, *Designer's Illustrated*, *The Professional Photographer*, *Studio Photography* and *Shutterbug*. An accomplished fine-art/landscape photographer, Isola counts on Canon for rugged reliability and uncompromised image quality.

#### SMALL PRODUCT



**Michel Tcherevkoff**

Explorer of Light

#### A Superb Creativity Tool

The recipient of more than a hundred awards for creativity, Michel Tcherevkoff has captured images and exhibited his work around the globe. He is known for his unique ability to create visual metaphors for advertising, corporate, design and editorial clients. His signature style is “reality with a twist” — finding the extraordinary in the ordinary. For Tcherevkoff, the EOS System stands alone as a photographic tool, enabling him to experiment with design and color as with no other camera system.

### Digital Capture Redefined

Once in a while, a new tool comes along that recalibrates our capabilities...a technological tour de force that forever changes our perception of what is and is not possible...a professional instrument that expands the boundaries of creative communication. The Canon EOS-1Ds Mark III is just such a tool. True to the EOS-1 legacy, this remarkable camera redefines the state of the DSLR (Digital Single-Lens-Reflex) art in no uncertain terms.

#### ARCHITECTURE



**Norman McGrath**

Explorer of Light

#### Specialty Lenses for Specialized Shooting

Educated as an engineer, London-born photographer Norman McGrath transitioned into his career as an architectural photographer after moving to New York in 1956. His work has appeared in every major architectural publication worldwide, and shooting assignments and workshops have taken him everywhere. McGrath credits Canon and the EOS System's ability to deliver images, at one time only possible with more cumbersome 4x5 view cameras.

#### ASTRONOMY



**Jennifer Wu**

Explorer of Light

#### Beauty in the Eye of the Photographer

Award-winning nature photographer Jennifer Wu travels extensively throughout the United States and Europe to capture her striking images. Her commercial work has appeared in numerous local, national and international publications. Wu's lifelong quest to capture the elusive and unrecognized beauty in nature pushes her to ever more challenging adventures. The Canon EOS System is her choice for recording those magical moments.

# Get the Big Picture and the Smallest Detail

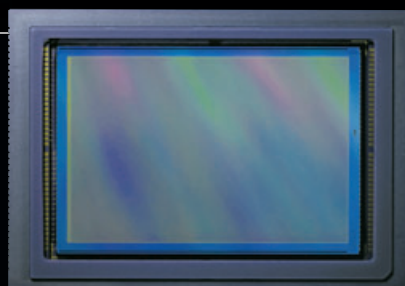

The EOS-1Ds Mark III 21.1 Megapixel Full-Frame CMOS Sensor delivers a high-resolution image of exacting precision, yielding a whopping 60MB file in Adobe® Photoshop®, with superb data density for enhanced large-output capabilities and post-processing cropping flexibility. Actual size shown above.

## Exceptional Canon Full-Frame CMOS Technology

The EOS-1Ds Mark III incorporates a Canon CMOS sensor, which delivers approximately 21.1 Megapixels (5616 x 3744 pixels). The recording area of the sensor is 36 x 24mm, which is equivalent to the full-frame size of the 35mm film format. Compared to typical smaller digital camera sensors, the Canon full-frame sensor can accommodate a tremendous pixel count while maintaining larger

individual pixel site size. Larger sites improve light gathering capability, enabling the sensor to produce a cleaner, more noise-free image.

EOS Digital SLR cameras with full-frame sensors let you use interchangeable lenses exactly as you would with 35mm film SLR cameras. They let photographers use the entire range of superb Canon EF lenses without a conversion factor, making it possible to take full advantage of the specific optical characteristics for which the lenses were designed. This is an important benefit for photographers who have sizable EF lens collections. [76](#)

## Ultra-High-Resolution Image Capture

The 21.1 Megapixel Full-Frame CMOS Sensor captures images with stunning detail and precision. The resulting high-resolution image files ensure exceptional reproduction quality, with generous data density for enhanced large-output capabilities and post-processing cropping flexibility. [76](#)



LARGE PRODUCT

EOS-1Ds  
Mark III

*“As photographers, we dream and produce images. Canon has also dreamed to give us one of the most powerful imaging tools in the world today with the Canon EOS-1Ds Mark III, its Dual “DIGIC III” Image Processors and an astounding 21.1 Megapixel Full-Frame CMOS Sensor that makes your image pop off the page like this one.”*



*Gil Smith*  
Explorer of Light

## The Canon CMOS Advantage

Canon CMOS sensors — designed and manufactured by Canon for exclusive use in Canon digital cameras — provide a number of important advantages over sensors typically found in other digital cameras: Their significantly reduced power consumption helps extend battery life and eliminates performance problems related to increased heat and noise. They deliver fast operation, taking full advantage of multi-channel architecture to provide standout combinations of high resolution and high-speed image capturing performance. In addition, a multi-layer low-pass filter is placed in front of the sensor to isolate false colors that the sensor may detect. Canon CMOS sensors also incorporate a novel noise reduction system that records the noise of each pixel prior to exposure then automatically subtracts that noise. Lauded by the best in the business, Canon’s CMOS sensors deliver outstanding resolution and signal purity, making them ideal for the most critical photographic applications. [76](#)

## Extended RAW Recording Capabilities

The EOS-1Ds Mark III can capture RAW and sRAW (Small RAW) images. This added versatility is ideal for photographers who prefer the control afforded by RAW capture in shooting situations that do not require the camera’s full resolution capability. Options are also provided for simultaneous RAW+JPEG and sRAW+JPEG recording with an extensive choice of JPEG sizing options. [82](#)

## Smoother Color Tonality

The EOS-1Ds Mark III employs powerful 14-bit converters to process the output of the imaging sensor. Each color channel provides 16,384 separate steps of brightness, from darkest to lightest. This ensures smoother tonal transitions and more natural gradations. 16,384 distinct tones can be recorded in each color channel, with every click of the shutter — even JPEG images start using 14 bits of tonal data! [77](#)



# Technology at One with Nature



## Rugged Weather-Resistant Design

The ideal professional camera is rugged yet not so massive as to compromise usability. The entire body of EOS-1Ds Mark III, including its internal chassis and mirror box, is

Magnesium alloy body and location of major water-resistant measures.



made of an advanced magnesium alloy. In lesser cameras, these parts are typically made of composite materials. Exceptionally strong and rigid, this alloy results in a camera that can truly withstand the punishment routinely meted out by many professional photographers. At the same time, it makes the camera lighter for improved handling and maneuverability.

Extensive weatherproofing ensures true reliability, even when shooting in harsh environments. Rubber gaskets are used at nearly every joint and seam — including around the battery compartment cover, memory card door and flash shoe — to keep out moisture and dust. **81**

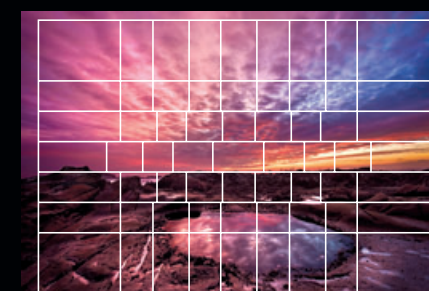

## 63-zone Metering System

A 63-zone metering sensor combined with sophisticated metering algorithms delivers more precise and stable exposure calculation over a wider range of shooting situations. Both available-light and flash metering performance have been improved. The metering sensor zones optimally match the 19 primary AF points. Photographers can choose from among automated Evaluative, Partial area (8.5% at the center), Spot (2.4% at the center), Multi-Spot and Center-Weighted average metering modes. **79**

## A Full-Frame Performance Standard

The CMOS sensor developed by Canon for the EOS-1Ds Mark III delivers approximately 21.1 effective Megapixels (5632 x 3750 pixels). It makes possible ultra-high-resolution digital photography, and the large amount of image data recorded result in enhanced large-output capabilities and effortless post-processing flexibility. **76**

*The EOS-1Ds Mark III is a wonderful tool that has made photography fun again for me. It is*

*light and rugged, with a very long battery*

*life, all very important features in my backpack. It provides me with a similar experience to shooting with my 4 x 5 camera, without the bulk, weight and dark cloth. Most importantly, the image quality is superb, with fine detail and smooth, continuous tones apparent throughout the file. Kudos!"*

**Vincent Isola**  
Explorer of Light



# Dependable, Repeatable High Image Quality



The Wireless File Transmitter WFT-E2A integrates elegantly with the EOS-1Ds Mark III, is powered by the camera body and is as durable and weather-resistant as the camera itself.



With 10x magnification

## Large 3.0-inch LCD Monitor with Live View Function

The 3.0-inch LCD monitor on the EOS-1Ds Mark III provides the photographer with a large, bright, detailed view of

images and graphical data. The bigger image area makes it easier than ever to confirm capture, check memory card contents, confirm shooting parameters and access all menu options.

Moreover, the EOS-1Ds Mark III features a sophisticated Live View Function, which makes the 3.0-inch LCD monitor a real-time finder. When the Live View Function is enabled, the reflex mirror is locked up and the shutter opened. The image output from the CMOS sensor will be displayed in real time on the LCD monitor at 100% coverage. A selectable portion of the image can be magnified by 5x or 10x to aid in precise manual focusing. Manual focus, exposure check, composing and shooting can all be accomplished in this mode.

Live View Function is convenient for tripod-mounted shooting, macro work and other situations in which it would be a physical strain to keep the eye at the viewfinder. The Live View Function image can also be displayed on a TV monitor, which is ideal for showing images, as they are being composed, to clients and portrait subjects. **82**



Highlight Tone Priority: ON



Highlight Tone Priority: OFF

## Highlight Tone Priority

Activated via a Custom Function, the Highlight Tone Priority mode employs sophisticated processing algorithms to preserve greater detail in image highlight areas — a perennial problem for digital photographers, especially those who work in bright sunlight or contrasty studio lighting. Highlight Tone Priority actually expands the available range of capture in the highlights, yet it exacts no penalties in either shadow detail or camera performance. It benefits photographers who shoot RAW images as well as those who rely on in-camera processing. **77**

## 21.1 MEGA PIXELS CMOS Stunning Image Quality

The EOS-1Ds Mark III features a Canon full-frame 21.1 Megapixel CMOS sensor. Compared to typical smaller digital camera sensors, the Canon full-frame sensor can accommodate a tremendous pixel count while maintaining larger individual pixel site size. Larger sites improve light gathering capability, enabling the sensor to produce a cleaner, more noise-free image. The Canon full-frame sensor thus delivers ultra-high-resolution images of exacting precision with glorious color richness and tonal accuracy. **78**

*The EOS-1Ds Mark III is great! The ability to capture fine image detail is of paramount importance in my work, and this camera truly delivers.*



*What also impressed me is the precise rendering of tonal nuance over a wide range of light values, which is equally important in my images. This camera's features — like the 3.0-inch LCD, Live View Function and improved wireless capabilities — are exactly what I've wanted for tabletop work. A superior tool... a joy to use."*

**Michel Tcherevkoff**

Explorer of Light

# Record with Precision and Artistry



### Canon EOS Tilt-Shift Lenses

Canon TS-E lenses are capable of tilt and shift movements that normally require the use of technical view cameras. Tilt movements alter the angle of the plane of focus between the lens and the focal plane, making broad depth-of-field possible even at wider apertures. These capabilities greatly expand the versatility of the EOS System and are ideal for specialized applications, such as architectural photography.

### The Full-Frame Optical Advantage

Digital SLR cameras with smaller sensors, by comparison, require a focal length conversion factor that effectively narrows the field of view as though you've added a telephoto converter. EOS Digital SLR cameras with full-frame sensors let photographers use the entire range of superb Canon EF lenses without a conversion factor, making it possible to take full advantage of the specific optical characteristics for which the lenses were designed. 76

### 63-zone Metering System

A 63-zone metering sensor combined with sophisticated metering algorithms delivers more precise and stable exposure calculation over a wide range of shooting situations. Photographers can choose from among Evaluative, Partial area (8.5% at the center), Spot (2.4% at the center), Multi-Spot, and Center-Weighted average metering modes. 79

### Highlight Tone Priority

The Highlight Tone Priority mode can be activated via Custom Function to help preserve greater detail in image highlight areas. It actually expands the available range of capture in the highlights, yet it exacts no penalties in either shadow detail or camera performance. It benefits nearly all professionals — for example, a nature photographer shooting winter snow scenes, a wedding photographer seeking to preserve detail in the bride's dress, or an architectural photographer facing a high-contrast scene in bright sunlight. 87

### Wide Dynamic Range

The outstanding image capture performance of the Canon Full-Frame CMOS sensor, the extended bit depth of the A/D converters, and the advanced design of the Dual

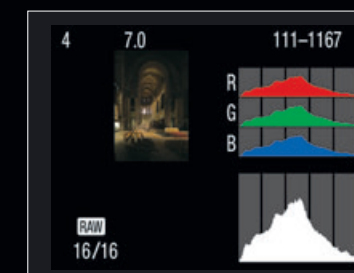

“DIGIC III” Image Processor ensure not only abundant detail but also amazing dynamic range. The EOS-1Ds Mark III thereby addresses a critical shortcoming among many of today's digital cameras. It is better able to capture a wide range of light values without blowing out highlights or losing shadow detail. Subtle tonal gradations are also more accurately recorded.

*“I much enjoyed using the EOS-1Ds Mark III. It is a superb piece of equipment capable of holding its own when*



*compared to a 4 x 5 view camera. With its extraordinarily high resolution in combination with ease of operation, I predict this will become the tool of choice for many architectural photographers.”*

**Norman McGrath**

Explorer of Light



# Advanced Capabilities for Specialized Applications



## Lenses and Accessories for High-Magnification Photography

Four Canon EF Macro lenses, a Life-Size converter, two extension tubes and three screw-on close-up lenses make the EOS System lineup a formidable tool for precision high-magnification photography, revealing detail undetectable by the unaided human eye. Macro Twin Lite and Ring Lite options provide riveting close-up lighting solutions.



MP-E 65mm f/2.8

## GPS Support for Field Work

The optional Wireless File Transmitter WFT-E2 II A/ WFT-E2A (for EOS-1Ds Mark III and EOS-1D Mark IV), the WFT-E4 II A/ WFT-E4A (for EOS 5D Mark II), the WFT-E5A (for EOS 7D) and the WFT-E3A (for EOS 50D) can communicate with compatible third-party GPS devices connected via USB. Latitude, longitude, altitude and Universal Time are all recorded in each image's EXIF shooting data. This enables location coordinates to be recorded for each picture as it's taken.



Wireless File Transmitter WFT-E2 II A

## Wide ISO Range

By combining the excellent image capture capabilities of the Canon CMOS sensor with advanced data processing technologies, the EOS-1Ds Mark III offers an extraordinarily

wide ISO range, making it possible to shoot even in previously impossible lighting conditions. The standard ISO range of 100–1600 can be extended to a remarkable low end of 50 and a high end of 3200. More important, the low-noise performance at high ISO settings makes the entire range usable in real-world shooting situations.

## Sophisticated Flash Capabilities

Canon E-TTL II technology incorporates distance information from compatible EF lenses to ensure a meticulously precise flash exposure and deliver versatile lighting control. Canon EX Series Speedlites provide advanced wireless and automatic multiple-flash capabilities to deliver magnificent lighting solutions for a wide variety of specialized shooting applications.



Wireless Speedlite Transmitter ST-E2

## EOS Integrated Cleaning System

Because professional photographers must change lenses in all kinds of adverse environments, Canon invented the Integrated Cleaning System, which uses ultrasonic vibration to remove dust that can settle on the sensor surface.



Self-Cleaning Sensor Unit

*“On a recent trip to the White Mountains of California, the camera stood up to the high heat of the day, the bitter cold of nights, and rain didn't faze the camera's weather sealing. The long battery life is essential for cold nights. Other cameras with shorter battery life give up during long exposures in low temperatures. The EOS-1Ds Mark III is the perfect camera for photographing nature and the stars.”*

**Jennifer Wu**  
Explorer of Light

# EOS-1D

## Mark IV

### *The Featured Professionals*

#### WILDLIFE



**Arthur  
Morris**

Explorer of Light

#### **Taking Flight**

After being an elementary school teacher for 23 years, Arthur Morris picked up a camera and would go on to become a renowned photographer of birds, with images published in *Audubon*, *National Geographic* and *Nature Photographer*. The Canon EOS high definition LCD monitor faithfully reproduces the hues of his subjects, allowing Morris to capture creatures as famous for their intricate coloring as their colorful displays.

#### SPORTS



**Peter  
Read Miller**

Explorer of Light

#### **The Moment of Victory**

A respected sports photographer for over 20 years, Peter Read Miller has covered eight Olympics, 14 NBA finals and 34 Super Bowls, plus numerous other events ranging from the Kentucky Derby to World Championship Freestyle Wrestling. Capturing the perfect catch or slam-dunk as it happens, Miller depends on Canon EOS digital SLR cameras and their blisteringly fast autofocus technologies so that the victor's glory lives on forever.

#### PHOTOJOURNALISM



**James  
Nachtwey**

Explorer of Light

#### **Bearing Witness**

James Nachtwey has devoted himself to documenting wars, conflicts and critical social issues, from the deserts of Africa to the jungles of Central America. Requiring a camera that is durable, strong and resistant to the elements is absolutely essential to Nachtwey's work, and Canon EOS digital SLRs deliver. With Canon, Nachtwey captures some of the most haunting images in photojournalism.

### Designed to Succeed. Designed to Exceed.

A remarkable combination of imaging performance and high-speed shooting capability, it offers performance that's nothing short of stunning: the flagship of the Canon EOS series, the EOS-1D Mark IV. Offering the most comprehensive combination of speed and accuracy available today, the EOS-1D Mark IV is the true professional choice. With its APS-H sized 16.1 Megapixel CMOS Image Sensor, Dual DIGIC 4 Image Processors and a spectacular ISO expandable up to 102400, the EOS-1D Mark IV is designed to surpass expectations. With a completely redesigned 45-point AF system, including 39 cross-type points, plus 10.0 fps shooting, spectacular Live View shooting, Full HD video recording and a host of powerful features to enhance every facet of the shooting process, it's clear that there's nothing like it.

#### WEDDING/PORTRAIT



**Charles  
Maring**

#### **To the Stars**

An acknowledged pioneer in the digital cinema revolution, Charles Maring taps Canon digital SLR cameras' abilities to capture both stills and HD video of some of the most glittering weddings in Hollywood, with his footage being shown on *Entertainment Tonight* and *Extra* and his stills in several wedding books. Capturing special moments in a variety of ways is a Canon EOS hallmark, getting every sparkle and smile.

#### WEDDING/PORTRAIT



**Sandy Puc'**

Explorer of Light

#### **Romance in Soft Light**

Her sets range from natural, window-lit scenes to elaborate fairytale tableaux, so Sandy Puc' relies on the high ISO performance of the Canon EOS System for beautiful, timeless imagery. Tapping the romance of soft light and shadow, Puc' depends on Canon for grainless and sharp shots, even if taken in dim light. Puc' also values the journalistic style of her EOS digital SLRs, capturing a soft, romantic vision with a technologically advanced tool.

# Clear and Detailed Viewing



## Clear View II LCD

The EOS-1D Mark IV features the finest Canon LCD screen to date: the high resolution, 3.0-inch Clear View II VGA LCD has 920,000 pixels and provides an amazing level of clarity and sharpness with a 160° angle of view. It's ideal not only for confirming focus and composition, but for composing and shooting in Live View mode, or when shooting video. It features a tempered glass protective cover with an optical elastic resin filling between the actual LCD and glass cover that minimizes internal reflections and improves visibility in bright viewing situations. During image playback, pressing the illumination button displays an LCD brightness screen, so brightness can be adjusted quickly and easily. [81](#)

## LiveView MODE

Live View function settings screen. Image review, AF, Drive, ISO, Grid view and size, plus other menus can be accessed without leaving Live View mode, enabling the photographer to tailor-fit their view, easily. The EOS-1D Mark IV's Live View shooting is enhanced with three improved AF modes: in Live mode, AF is achieved with contrast detection according to AF point selection. In Face detection Live mode, the camera



Live View shooting information display

detects the human face automatically and focuses with contrast AF. If multiple faces are detected, the largest face closest to the center is chosen automatically. Alternative faces can be selected via the camera's Multi-controller. In Quick mode AF, phase-difference detection AF with the AF sensor is completed as in normal AF. When focus is achieved, the image appears automatically. In Live View mode, the EOS-1D Mark IV's exposure simulation mode displays the image as it would record based on chosen exposure, helpful in avoiding under or overexposed images. Additionally, exposure control and drive modes are the same as with viewfinder shooting, making for no-compromise photography whether composing through the viewfinder or on the EOS-1D Mark IV's Clear View II monitor. [82](#)

detects the human face automatically and focuses with contrast AF. If multiple faces are detected, the largest face closest to the center is chosen automatically. Alternative faces can be selected via the camera's Multi-controller. In Quick mode AF, phase-difference detection AF with the AF sensor is completed as in normal AF. When focus is achieved, the image appears automatically. In Live View mode, the EOS-1D Mark IV's exposure simulation mode displays the image as it would record based on chosen exposure, helpful in avoiding under or overexposed images. Additionally, exposure control and drive modes are the same as with viewfinder shooting, making for no-compromise photography whether composing through the viewfinder or on the EOS-1D Mark IV's Clear View II monitor. [82](#)

## Improved Menu Screens

Canon has refined the EOS-1D Mark IV menu screens for faster, easier control of settings. With 256 colors, proportional fonts, gradations and animations, plus 25 languages, every screen is refined and intelligently designed.

## Ergonomic Design and Button Layout

Improving on the design of the flagship EOS is no small feat, but the EOS-1D Mark IV offers refinements and improvements in the design of covers, buttons and more, for improved, more intuitive operation. The Multi-controller has an improved shape and protrudes more. The AE lock and AF buttons all protrude more and have improved stroke, while all terminal covers are attached and well-sealed.

*"The Canon EOS-1D Mark IV features fast and sure initial focusing acquisition and consistently accurate*



*focusing. My images of birds were all razor-sharp, even their eyes. With static subjects, the ability to quickly select any one of the 45 autofocus points is a huge plus. And the high resolution LCD monitor makes it a snap to evaluate image composition and sharpness."*

**Arthur Morris**

Explorer of Light







©2009 James Nachtwey. All Rights Reserved.



©2009 James Nachtwey. All Rights Reserved.

# Reliability Second to None



## Amazing Magnesium-alloy Body

Built to endure the worst possible environments, the EOS-1D Mark IV has a lightweight and incredibly strong magnesium-alloy construction. Built to go wherever the photographer dares, it's ready for anything. It features durable, baked-on paint with a grippy surface that keeps the camera in hand, ready to shoot. 

## Shutter Durability

The EOS-1D Mark IV's shutter unit has a durability of 300,000 shutter cycles. And the rest of the camera is built to last — the mechanical parts, electronics, optics and operation controls are constructed to the highest standards to perform brilliantly, whether it's the camera's 30th or 300,000th shot. 





Shutter Unit

## Numerous Weather Seals to Ensure Dust and Water Resistance.

All the EOS-1D Mark IV's controls, buttons and external covers are dust- and water-resistant, ensuring uninter-

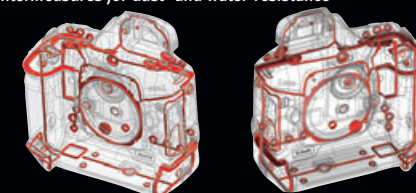
Countermeasures for dust- and water-resistance



rupted operation whether shooting in the rain, in a windstorm or anything in between. When the EOS-1D Mark IV is used with a dust- and water-resistant EF lens or external Speedlite, the entire camera system is nearly impervious to the elements. 

## EOS Integrated Cleaning System

Dust is managed with the advanced Canon EOS Integrated Cleaning System. To combat stray dust that can enter the camera

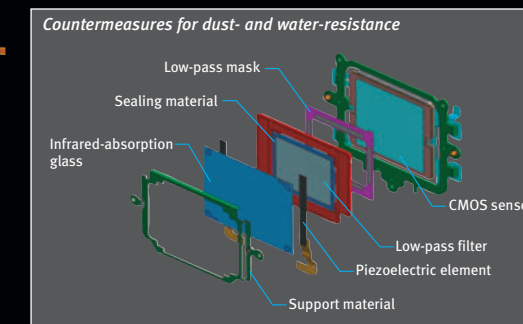

when changing a lens, the Canon Self Cleaning Sensor's low pass filter cleans itself automatically with ultrasonic vibrations every time the camera is turned on or off. Removed dust adheres to material beneath the filter to ensure it stays off. Dust missed by the cleaning unit is captured by the Canon Dust Delete Data Detection software and can be removed from the image file. By ensuring the sensor is free of dust and debris, the camera guarantees a cleaner image. 

*"The durability of the Canon EOS-1D Mark IV is as tough and rugged as its predecessor, the*



*Mark III. The Mark IV withstands the harsh conditions*

*encountered by photojournalists — dust and rain and the cold. Bang it around and it keeps on shooting. When you're way out on the edge, with no second chance, you want to be using a camera you can rely on."*

**James Nachtwey**

Explorer of Light





# High Quality, High Definition Stills and Video



**16.1 MEGA PIXELS CMOS** **High Image Quality Stills**  
The EOS-1D Mark IV employs a developed 16.1 Megapixel CMOS sensor which records images of amazing clarity and size, perfect for most any application. At 27.9 mm x 18.6 mm, the sensor records at 1.3x the lens crop of 35mm (full-frame). 

**DIGIC 4** **Dual DIGIC 4 Image Processors**  
The EOS-1D Mark IV's Dual DIGIC 4 Imaging Processors ensure that images are captured, processed and saved with remarkable speed — up to 10 frames per second! The Dual DIGIC 4 Image Processors work in concert with Canon CMOS sensor chips to dramatically enhance image quality and deliver a more intuitive, responsive camera. 

**Noise Reduction Technology**  
With advanced, on-chip noise reduction technology, the EOS-1D Mark IV is fully equipped to counter the digital noise that can occur when shooting at high ISOs, or in the bright and dark areas of the image. Sophisticated hardware and software designs work to ensure continuous, film-like smoothness in all images is captured. 

**14-bit A/D**  
The EOS-1D Mark IV employs a 14-bit converter to process the output of the CMOS sensor. 14-bit means smooth tones, natural gradations and phenomenal colors. RAW images are recorded at 14 bits so that processed 16-bit TIFF images contain a maximum range of tones. 

**EOS Movie FULL HD** **High Quality Video**  
The EOS EOS-1D Mark IV's video mode eliminates the need to bring a video camera when



shooting both moving and still images. Plus, it allows for full use of the vast range of Canon EF lenses. Video shot on a large sensor camera is enhanced by image characteristics intrinsic to SLR photography, like the EOS-1D Mark IV's expansive range of ISO sensitivities, full manual control over exposure and depth-of-field, plus lens choice and more. Full HD Video is captured at 1920 x 1080 resolution at 24, 25 or 30 frames per second. Other recording sizes include HD at 1280 x 780 (50/60 fps) or SD/VGA at 640 x 480 (50/60 fps). Sound is recorded either through the EOS-1D Mark IV's built-in microphone or through an external microphone connected to the Microphone Terminal, and video can be viewed on the spot through the EOS-1D Mark IV's HDMI port, USB port or analog AV output. 



*"The EOS-1D Mark IV is a revolutionary camera that allows amazing levels of creativity that reach far beyond our client's expectations. The convergence of stills and motion picture is a major shift in the evolution of wedding photography, and its incredible low light sensitivity allows us to capture beautiful moments for print and in motion with clarity and quality that is second to none. Photography is more personal than ever, which makes the EOS-1D Mark IV the ultimate camera for wedding photographers."*

**Charles Maring**



# Ready to Go No Matter the Light



## Wide ISO Range

The EOS-1D Mark IV has the largest ISO range in the history of EOS cameras, with an improved normal range of ISO 100 – 12800 and an expanded range of 50 to 102400! The combination of Dual DIGIC 4 Image Processors and the Canon CMOS sensor ensures that even at a setting of 102400, noise is kept to a minimum. **77**

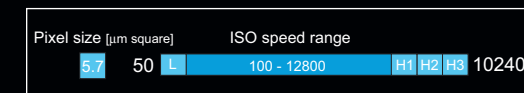

## Noise Reduction Technology

The EOS-1D Mark IV's CMOS sensor incorporates a unique on-chip noise reduction technology to deal with both fixed pattern and random noise. It features a photodiode construction that results in an improved photoelectric conversion rate. This speedier conversion means faster

and increased sensitivity at the pixel level. This speed and sensitivity, in combination with new gapless microlenses plus less space between microlenses and photodiodes, means a better signal-to-noise ratio, which translates to better real world performance and image files. **76**

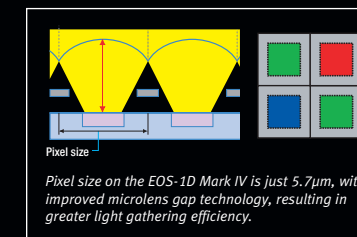

## 16.1 Megapixel CMOS Sensor

The EOS-1D Mark IV's amazing CMOS sensor captures a tremendous level of resolution with striking detail down to each individual pixel. With size to spare, it's easy to crop images or to make massive enlargements without concern of losing detail. A marvel of technical innovation, the EOS-1D Mark IV's CMOS sensor incorporates a number of significant refinements that enhance the performance and speed in the capture of each image. Thanks to advanced, in-house design and manufacturing, the EOS-1D Mark IV's sensor has more pixels than its predecessor with less digital noise, higher ISO sensitivity and greater dynamic range. **76**

## Dual DIGIC 4 Image Processors

The EOS-1D Mark IV's Dual DIGIC 4 Image Processors work in concert with the Canon CMOS sensor chips to improve image quality and make every camera action faster and more intuitive. Features like Face Detection Live mode AF, Full HD Video, the amazing Canon Auto Lighting Optimizer, Lens Peripheral Illumination Correction and more are all possible thanks to the speed and processing power of the EOS-1D Mark IV's Dual DIGIC 4 Image Processors. **77**

*"The EOS-1D Mark IV is one of the most dynamic capture devices yet. Working with children requires a lot of patience and speed. The Canon EOS-1D Mark IV is perfect. It gives me the ability to shoot a more journalistic style and capture the true essence of my subjects. The high ISO allows me time to think about the final image, rather than worry about where I am going to find the light. I have the freedom to work fast and it provides the superior image quality my clients demand."*



**Sandy Puc'**  
Explorer of Light



# EOS 5D

## Mark II

### *The Featured Professionals*

#### WEDDING



**Clay Blackmore**

Explorer of Light

#### **Stunning Stills and HD Video with One Camera**

Clay Blackmore is a renowned innovator in the world of wedding photography and portraiture. Blackmore's style blends the beauty and timelessness of classical portraiture with the spontaneity and appeal of photojournalism. A celebrity and society favorite, his clients include entertainment, sports and political luminaries. Blackmore's camera system of choice — Canon EOS, now with the added Full HD video capture capability — opens new doors of creativity and opportunity.

#### DOCUMENTARY



**Joachim Ladefoged**

#### **Images That Tell the Real Story**

Joachim Ladefoged has worked in more than 50 countries, winning international recognition for covering war, conflict and ordinary life around the world. The first Danish photographer to win a first place award at a *World Press Photo* competition, he is credited with being one of the driving forces behind the new wave of Danish photojournalism. Ladefoged's unique documentary style, evident in both his still and video work, is perfectly complemented by the EOS System.

#### NATURE



**George Lepp**

Explorer of Light

#### **A System with Real Flexibility and Power**

A leader in the rapidly advancing field of digital imaging, George Lepp is best known as a celebrated outdoor and nature photographer, lecturer and author. His passions for natural beauty, technical precision, cutting-edge technology and environmental responsibility are revealed in his beautiful and compelling photographic images. In the EOS System, Lepp has found unequalled flexibility and powerful detail capturing ability.

### Exceptional Performance, Phenomenal Image Quality

With its superb 21.1 Megapixel Full-Frame CMOS sensor, latest-generation DIGIC 4 Image Processor, high-performance AF sensor, high-resolution VGA 3.0-inch Clear View LCD monitor and many additional advanced features, the EOS 5D Mark II sets new standards for image quality, responsiveness, shooting flexibility and versatility. It is an SLR ideal for professional and serious amateur photographers alike. Capabilities such as Full HD video recording and expanded Live View Function provide more applications beyond the traditional scope of SLR cameras, creating new possibilities in professional use. Innovative image enhancement features further ensure the highest quality image capture. The free Firmware Upgrade 2.0.3, adds 24p (23.976) and 25p, adjusts 30p to 29.97, adds manual control of audio in 64 levels, adds a histogram display for judging exposure in manual video mode, allows movie shooting in Av and Tv modes, and adjusts audio recording from 44.1 KHz to 48 KHz further solidifying the EOS 5D Mark II as a seminal media tool.

#### CELEBRITY



**Greg Gorman**

Explorer of Light

#### **Spectacular Images, Superb Camera Handling**

From personality portraits and advertising campaigns to magazine layouts and fine art work, Greg Gorman has developed and showcased a discriminating and unique style in his profession. His photography is timeless, and his images paint pictures of human nature in its infinite range. With advanced capabilities, the EOS System provides Gorman with a powerful, practical alternative to medium format cameras.

#### ADVERTISING



**Tyler Stableford**

Explorer of Light

#### **Performance Under Pressure**

Aspen-based photographer Tyler Stableford has earned a worldwide clientele for his commercial and editorial photography. In 2005, *Men's Journal* named him one of the "World's Greatest Adventure Photographers" for his work exploring Iceland's glacier caves. The rigors of outdoor commercial and action/adventure shooting demand a camera system that delivers faultless image quality with unequivocal ruggedness and durability — all reasons why Stableford shoots with the Canon EOS System.

# Brilliant Stills, Spectacular Video



FULL FRAME  
CMOS

EOS 5D Mark II  
Full-Frame  
CMOS Sensor  
(Actual Size)

## An Extraordinary Still Camera

The EOS 5D Mark II features an advanced autofocus system that uses nine primary AF points with six supplemental assist points around the center point. It ensures fast, accurate AF with enhanced performance in low-light situations.

The EOS 5D Mark II also features the innovative Highlight Tone Priority function, which takes full advantage of the imaging sensor's wide dynamic range and uses sophisticated exposure control and image processing to preserve greater detail in highlight areas.

The Canon 21.1 Megapixel Full-Frame CMOS Sensor combined with the latest-technology Canon DIGIC 4 Image Processor delivers images of stunning quality. Captured images exhibit exceptionally low noise even when shooting at higher ISO settings, making possible high-quality capture in a wide range of available light conditions. **126**

## Switch from Stills to Video

The full-frame sensor and DIGIC 4 Image Processor also make it possible to shoot superb Full HD (high definition) video. The EOS 5D Mark II can shoot Full HD video at 1920 x 1080 pixels or SD (standard definition) video at 640 x 480 pixels with a frame rate of 30 fps. The camera provides

an HDMI output for full-resolution digital transfer of Full HD video to monitors, projectors and other post-production equipment. **128**

## Durable and Weather-Resistant

The EOS 5D Mark II features a body made of magnesium alloy, making it exceptionally rigid and durable but still sufficiently lightweight to ensure excellent portability and handling. The body is also extensively fitted with seals and gaskets to keep out moisture and dust. The result is a tough, dependable camera body that withstands the rigors of professional use. **81**

## Canon REALiS SX80 Projector

REALiS projectors combine the brilliance and sharpness of LCOS (Liquid Crystal On Silicon) technology with Canon AISYS light engine technology. Native 1400 x 1050 (SXGA+) resolution and sRGB support assures crisp, detailed projected images, still or video. The projector's HDMI input supports Full HD (1080i/1080p) signals making it easy to view images directly from the EOS 5D Mark II. **135**

## Multiflash Lighting Without Wires

Canon EX-series Speedlites make multiple-flash photography simple. A Master Speedlite flash unit or transmitter can wirelessly control an unlimited number of additional Speedlites, creating myriad possibilities for lighting, no matter the location. Fully adjustable Master/Slave output ratios, modeling flash and advanced Canon E-TTL II flash exposure control make it easy to achieve the perfect lighting every time. **83** **90**

*“Canon has gone beyond my wildest dreams...a camera with amazing speed, image quality and high ISO capability with low noise...all packaged in a compact, durable body, and it even does HD video. This camera is the standout camera for wedding photography. The future of wedding photography is here!”*

**Clay  
Blackmore**  
Explorer of Light



# Lights, Camera, Action!



## Shooting Full HD with SLR Advantages



FULL FRAME  
CMOS

With more professional still photographers taking on crossover video shooting assignments, the EOS 5D Mark II fills a growing need. As a Canon EOS camera, you can use the entire range of EF lenses. And because the EOS 5D Mark II features a full-frame sensor, you don't have to concern yourself with conversion (crop) factors, thus maximizing your control of factors such as depth-of-field.

Superb video quality is ensured by 14-bit A/D converters, ensuring smoother tonal transitions and more natural gradations. Tonal reproduction is further enhanced by the Highlight Tone Priority feature, preserving greater detail in image highlight areas. Dynamic range is effectively expanded in this critical range of exposure, making gradations smoother and minimizing loss of highlight detail.

The EOS 5D Mark II delivers video and still images of stunning quality. Captured images exhibit low noise, ensuring exceptional playback clarity, detail and color purity. It also provides outstanding low-noise performance even when shooting at higher ISO settings, making possible high-quality capture in a wider range of light conditions. 



Picture Style

## Simplified Custom Camera Settings

Picture Style provides a number of presets that eliminate the need to make numerous individual changes to camera settings. The EOS 5D Mark II provides six factory preset styles and three additional custom presets. The Picture Style you

select for the Live View mode is used for video recording. Therefore, all settings registered in that Picture style — such as sharpness, color saturation, etc. — will be reflected in the captured video footage. 

## Tough and Dependable

The EOS 5D Mark II body is made of magnesium alloy, making it exceptionally strong and durable, yet lightweight. The body

is also extensively fitted with seals and gaskets to keep out moisture and dust. Rugged build quality is augmented by the Canon Self Cleaning Sensor Unit removing dust on the imaging sensor using ultrasonic vibration. A fluorine coating on the front surface low-pass filter also helps prevent the accumulation of sticky and moist dust particles. 



## Rapid, Responsive Still Shooting

A high-performance shutter assembly, fast autofocus system, advanced CMOS sensor, and state-of-the-art DIGIC 4 Image Processor combine to make the EOS 5D Mark II a nimble, responsive camera. Despite the huge amount of data associated with 14-bit, 21.1 Megapixel image capture, the EOS 5D Mark II can shoot continuously at 3.9 fps. Shooting speed is also enhanced by UDMA (Ultra Direct Memory Access) CF cards compatibility, which enables you to use the newer, faster UDMA CF cards.

*“A camera that meets the needs of today’s photographers. A small step for man, a giant step for photographers. A camera that ‘moves’ the ‘still’ world.”*

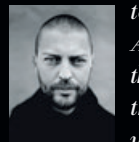

**Joachim  
Ladefoged**

# Exceptional Image Quality, Extreme Versatility



## Spectacular High-Resolution Capture

**21.1** MEGA  
PIXELS  
CMOS

The EOS 5D Mark II incorporates a 21.1 Megapixel Full-Frame CMOS Sensor that delivers still and video images of exceptional low noise and are unsurpassed in clarity, detail and color purity. The full-frame sensor enables you to use the entire range of Canon EF lenses with no need for conversion factors. For enhanced tonal reproduction, the EOS 5D Mark II incorporates Highlight Tone Priority, making gradations smoother and minimizing loss of highlight detail.

The EOS 5D Mark II also features Lens Peripheral Illumination Correction, which automatically corrects for light fall-off at the corners. Using a database of EF lenses, this corrective system works automatically at the time of capture when shooting JPEGs. With RAW images, the same correction can be performed using Canon DPP software. Another image enhancement features the Auto Lighting Optimizer; it automatically adjusts brightness and contrast during image processing. **178**

**EOS**

Integrated  
Cleaning  
System

## Rugged Dependability

The EOS 5D Mark II body is made of lightweight magnesium alloy, making it easy to handle and transport without sacrificing strength and durability. The body is also highly weather resistant thanks to the extensive use of seals and gaskets to keep out moisture and dust. The weather-resistant design is complemented by the Canon Self-Cleaning Sensor Unit. Part of the EOS Integrated Cleaning System, it removes dust on the imaging sensor using ultrasonic vibration. **181**

## Big, Bright, Clear View LCD Monitor

A 3.0-inch Clear View LCD (920,000 dots/VGA) monitor provides a large, bright, highly detailed display. The increased resolution makes it possible to view images with far greater detail and enhances the Live View Function capabilities. **181**

## HDMI Output

The camera provides an HDMI output for full-resolution digital transfer of Full HD video to monitors, Canon REALiS projectors and post-production equipment.

**HDMI**  
HIGH-DEFINITION MULTIMEDIA INTERFACE

## Advanced Flash Photography

The EOS 5D Mark II is fully compatible with the Canon Speedlite flash system. There are versatile solutions for macro photography such as the Macro Ring Lite MR-14EX, which features twin circular flash tubes that can be fired at equal or uneven power at ratios that can be varied over a six-stop range. The Macro Twin Lite MT-24EX provides a different, directional option for close-up, nature and macro photography. With either macro flash unit, one or more compatible EX-series Speedlites can be used as wireless Slaves for creative lighting solutions.

Canon E-TTL II flash exposure control uses the camera's Evaluative metering sensor — the same sensor that reads ambient light. This sophisticated system compares light values and accurately calculates the flash output required for optimum illumination of the main subject and background. It ensures balanced, natural lighting, for example, when using fill flash.

*“This is a great camera for outdoor and nature photographers! Its lightweight but sturdy body is easy to*

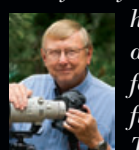

*handle and perfect for field work. The 21.1*

*Megapixel Full-Frame CMOS Sensor captures every detail of the landscape. The large, high-resolution LCD monitor with Live View is a real benefit for previewing images in the field. I'm especially excited about the high-definition video capabilities, a feature that makes this camera one of the most innovative and versatile creative tools I've seen yet.”*

**George Lepp**  
Explorer of Light

EOS 5D  
Mark II

# The Powerful Studio Alternative to Medium Format



## Richly Detailed, 21.1 Megapixel Image Recording

21.1  
MEGA  
PIXELS  
CMOS

High-resolution imaging is a primary reason medium format digital cameras are popular among studio photographers. With Canon EOS high-megapixel full-frame cameras, many professionals are rethinking their camera system choice for studio work. Noise is exceedingly low, ensuring captures of astounding clarity, detail and color purity. Moreover, the EOS 5D Mark II is supported by the entire range of Canon EF lenses, a comprehensive system of optics that is a true standout in the medium format world.

## WFT-E4 II A/WFT-E4A Wireless File Transmitter

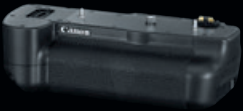
The WFT-E4 II A or WFT-E4A provides added camera handling versatility while providing advanced wireless file transfer and networking functionality. Attached to the camera, the WFT-E4 II A or WFT-E4A serves as a vertical grip, duplicating basic camera controls for easier vertical shooting. It provides wireless network connectivity, enabling various "tethered" shooting options, such as remote viewing for studio clients. The WFT-E4 II A or WFT-E4A also has a USB port that can be connected to an external storage device, multiplying the camera's recording media options. 

## Easy Camera Handling

The EOS 5D Mark II offers many advantages of medium format cameras, such as high-resolution image capture and

high image quality. The big difference, of course, is that the EOS 5D Mark II is a Canon EOS SLR. The camera handling is responsive and system support is simply amazing.

## High-Resolution Live View Function Capability



A 3.0-inch Clear View LCD (920,000 dots/VGA) displays large, detailed images, enhancing the camera's Live View shooting and image playback

capabilities. The EOS 5D Mark II also provides an HDMI output, which enables full-resolution digital transfer of Live View Function and playback images to in-studio HD monitors and projectors. 

## Fast-Response Shooting



The EOS 5D Mark II incorporates a high-performance shutter assembly, fast autofocus system, advanced CMOS sensor and state-of-the-art DIGIC 4 Image Processor. The combination enables continuous shooting at 3.9 fps despite the huge amount of data associated with 21.1 Megapixel image capture. Camera response is also enhanced by UDMA compatibility, which enables you to use the newer, faster UDMA CF cards. 

*"Having always been a big fan of the EOS 5D, the Canon EOS 5D Mark II is an astounding step forward, with its 21.1 Megapixel resolution full-frame sensor, superb image quality and 3.0-inch VGA LCD monitor in a compact, durable body. And with the ability to record High Definition Video, what more could anyone ask for?"*

**Greg Gorman**  
Explorer of Light

# Engineered to Let You Stay with the Action



### Dependable Performance Without the Extra Weight

The EOS 5D Mark II might be light in weight, but it's a "heavyweight" when it comes

to professional features and performance. The camera body is made of magnesium alloy, making it exceptionally strong and durable. The use of this advanced alloy, however, ensures weight is kept to a minimum, resulting in a camera that can be handled with ease and won't slow you down. The body is also extensively fitted with seals and gaskets to keep out moisture and dust. The result is a tough, dependable camera body that stands up to the demands of professional use. 

### Remarkable Shooting Speed

A high-performance shutter assembly, fast autofocus system, advanced CMOS sensor design, and state-of-the-art DIGIC 4 Image Processor combine to deliver crisp camera response and fast continuous shooting speeds. The EOS 5D Mark II shoots at 3.9 fps despite the huge amount of data associated with 21.1 Megapixel image capture.



### Astounding Image Quality

The Canon 21.1 Megapixel full-frame sensor combined with the Canon DIGIC 4 Image Processor delivers spectacular image capture with exceptionally low noise.

The EOS 5D Mark II maintains its trademark low-noise performance even when shooting at higher ISO settings, enabling the use of faster shutter speeds often needed in action photography.

**EOS** Integrated Cleaning System **Self Cleaning Sensor Unit**  
Photographers who must change lenses in dusty environments will appreciate the Canon Self Cleaning Sensor Unit. Part of the EOS Integrated Cleaning System, which uses both mechanical and software methods to effectively deal with dust accumulation on the imaging sensor, this self-cleaning unit employs an improved ultrasonic vibration mechanism and a fluorine coating on the front surface low-pass filter that better repels sticky and moist dust particles. 

### Large, High-Resolution LCD Monitor

A 3.0-inch Clear View LCD monitor with significantly increased resolution (920,000 dots/VGA) makes it possible to view images with far greater detail. The large overall size makes the display easier to use and more informative than ever. The screen's striking brightness ensures excellent viewing ability even in bright outdoor conditions. A built-in ambient light sensor automatically adjusts screen brightness as needed. 

*"When I'm shooting on a rock wall or a mountainside, I want to be able to capture world-class images with*

*the lightest possible equipment. For this shot, I used*

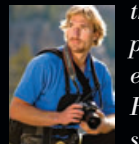

*Canon's EF 14mm f/2.8L II USM lens to capture both Jessa and the beautiful alpine environment. The EOS 5D Mark II's high-definition video capabilities revolutionize the way I work. With web and multimedia presentations playing crucial roles in our profession, capturing high-quality video alongside stills is more important than ever."*

**Tyler Stableford**  
Explorer of Light

# EOS 7D

## The Featured Professionals

### DOCUMENTARY



**Lauren Greenfield**

Explorer of Light

#### One Tool for the Job

A preeminent chronicler of youth culture as a result of her ground-breaking projects *Girl Culture*, *Fast Forward* and *Kids + Money*, Emmy-nominated Lauren Greenfield needed a single, versatile tool that produced top-rate stills and video. She found it in Canon EOS digital SLR cameras, and, freed from wrestling with multiple cameras and equipment, Greenfield can turn her unhindered concentration to her subjects.

### WEDDING/PORTRAIT



**Michele Celentano**

Explorer of Light

#### Images to Remember By

Describing her style as “natural and whimsical,” Arizona-based Michele Celentano has been recognized by Wedding and Portrait Photographers International for her images of weddings, families and new parents. Easy use of Canon EOS digital SLR cameras and her own vision has taken Celentano across the globe. Her I Will Remember You organization takes photos of those who otherwise would have no images for their loved ones.

### WEDDING/PORTRAIT

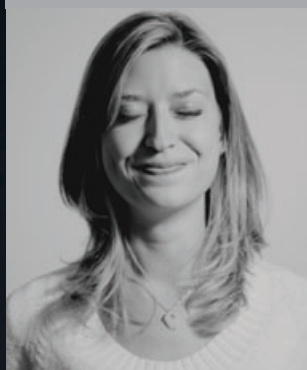

**Stillmotion**

#### Making the Memorable Easy

Producing quirky and unique takes on wedding and portrait photography, the Stillmotion Studio creates their trademark images by using extreme lighting, depth-of-field and other tricks of the trade. With Canon EOS digital SLR technology, stills and video can be taken by one piece of equipment, streamlining the entire photographic process and freeing Stillmotion’s photographers to do what they do best — getting the most memorable image.

## Beyond the Still.

With a host of phenomenal new features designed to enhance and speed up every facet of the photographic and moviemaking process, the EOS 7D represents a new level of photographic and filmmaking performance in its class. With its 18.0 Megapixel APS-C size CMOS sensor and Dual DIGIC 4 Image Processors, it shoots amazing stills and Full HD video without compromise. It has an entirely new, bright and customizable Intelligent Viewfinder with approximately 100% coverage, a newly designed AF system, plus rugged, refined construction for reliable pro-level performance anywhere, any time.

### BEAUTY



**Stephen Eastwood**

Explorer of Light

#### Beauty Is in the Eye

Describing his favorite kind of photography as “beauty, beauty and generally more beauty,” Long Island-born Stephen Eastwood uses Canon EOS digital SLR cameras to discern the subtle shades and hues of his subjects to make his trademark images. The exquisite detail afforded by Canon high resolution technology and the luminosity options of the EOS System’s dynamic range create the vivid colors and rich skin tones Eastwood strives to capture.

### CORPORATE/INDUSTRIAL

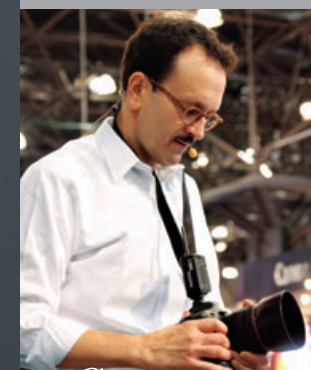

**Gregory Heisler**

Explorer of Light

#### Good Things in a Small Package

Although best known for his over 70 *Time* covers, where he turned his camera on names such as Bruce Springsteen, Bill Gates and Olympian Michael Phelps, Gregory Heisler’s work also appears in *Life*, *Esquire*, *GQ*, *Sports Illustrated* and many other magazines, along with campaigns for American Express, Nike and Dewar’s. Requiring an image-capturing tool that is light and compact, Heisler turned to Canon digital SLRs.

### PHOTOJOURNALISM



**Christopher Morris**

#### The Unflinching Eye

The US invasion of Iraq, the drug-fueled conflict in Colombia, the liberation of Kuwait, the civil wars in Afghanistan, Somalia, Yugoslavia and Chechnya — Christopher Morris goes with the soldiers to tell the story of war. Able to capture highly detailed stills and HD video, the lightweight and versatile Canon EOS SLR cameras he carries, with their low light and flash technologies, capture images with unflinching clarity.



# Capturing the Story, From Stills to Video



## Superlative Image Quality

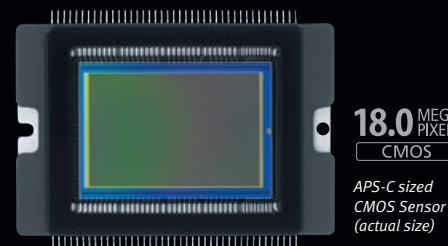

The EOS 7D features a superb, Canon designed, 18.0 Megapixel CMOS sensor that incorporates a number of significant refinements to enhance the capture of each image. Thanks to advanced, in-house semiconductor manufacturing, the EOS 7D's sensor has more pixels than any other APS-C sized sensor in the Canon lineup, with less digital noise, a higher ISO sensitivity (up to 12800 in H mode) plus a wider dynamic range than previously available. The EOS 7D employs a 14-bit converter to process the output of the CMOS sensor for smooth tonal transitions, natural gradations and striking color fidelity. The EOS 7D's Dual DIGIC 4 Image Processors help to ensure that images are captured, processed and saved with remarkable speed — up to 8.0 frames per second. **126**

## Full HD Video Capture

EOS 7D does not just shoot video clips, it offers the enhanced image quality, smooth frame rates and adaptive exposure compensation necessary in a professional movie making tool. Shooting video with the EOS 7D increases flexibility for the photogra-

pher by allowing full use of Canon's EF and EF-S lenses, including wide angle, macro, tilt-shift and fisheye, providing a wealth of depth-of-field and other creative shooting options once reserved only for still photography. By shooting video with a large sensor camera, it's simple to take advantage of the image quality and characteristics intrinsic to SLR photography. Combined with its size, image quality and flexibility, the EOS 7D is an all-in-one image-capturing tool. **126**

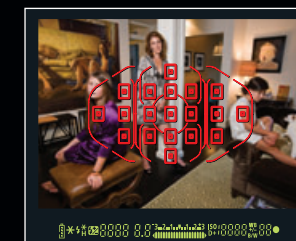

Viewfinder display

## Professional Level Performance

Capable of shooting up to 126 Large/JPEGs with a UDMA CF card at 8.0 fps, the EOS 7D is a perfect camera for action. The EOS 7D is

outfitted with a rugged, rotary magnet shutter, which, aided by the Dual DIGIC 4 Image Processors, ensures instant response and performance on par with most professional cameras on the market while outpacing every camera in its class. Featuring a revamped 19-point high-precision, all cross-type AF point system with dedicated microprocessors, the AF system helps to ensure the fastest, most accurate AF under a wide variety of shooting conditions. The EOS 7D also has a broad range of ISO settings, up to ISO 12800 in H mode, for finely-detailed dawn-to-dusk shooting. RAW images are recorded at 14 bits so that processed 16-bit TIFF images contain the full range of tonal values.

*"I'm taking advantage of the EOS 7D's ability to create high quality HD video footage from my 'still'*



*photography camera. I often conducted video interviews alongside my still photography; I never captured cinéma vérité footage simultaneously because of the bulkiness of the camera and the disruption of switching to another medium in the middle of unfolding events. The EOS 7D allows for subtle and seamless capture of vérité footage when the opportunity presents itself. I am just beginning to discover the possibilities."*

**Lauren Greenfield**

Explorer of Light



# Advanced Photography in A Whole New Light

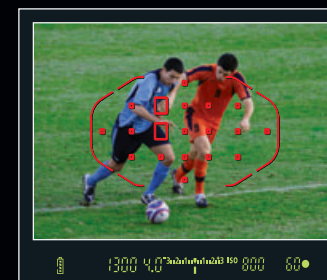

AF points display

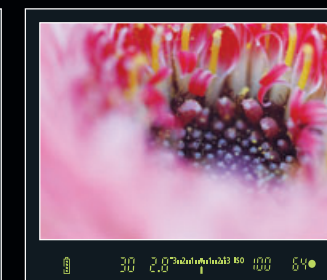

Hide all

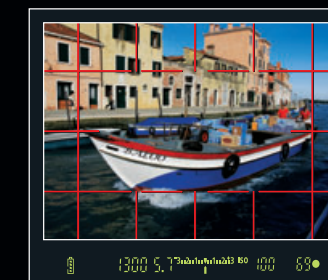

Grid display



Spot metering display

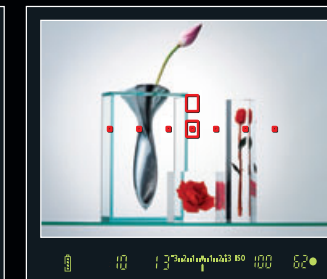

Dual Axis Electronic Level display



AI Servo AF tracking display



## New Viewfinder, Intelligent New Perspective

The EOS 7D features a bright, clear, completely redesigned viewfinder that offers approximately 100% coverage, 1x magnification, a glass pentaprism, a 29.4° angle of view and user-controlled dioptric adjustment. It also features the new Intelligent Viewfinder, which superimposes important shooting tools, like a grid display or the new Dual Axis Electronic Level, within the viewfinder. **80**



## Advanced 19-point AF System

Canon EOS SLR cameras have consistently featured cutting-edge AF technologies; the EOS 7D takes them a step further. The EOS 7D uses a brand new 19-point AF all cross-type system providing tremendous AF coverage and phenomenal control over focusing point selection. Any of the 19 high-precision, cross-type AF points can be selected automatically or manually. High-speed microcomputers in the EOS 7D use advanced algorithms that ensure

fast, accurate and responsive AF performance under the widest variety of conditions. Focus tracking is on par with the EOS-1D/1Ds series, and includes single point AF, a new Spot AF mode, and AF point expansion where AF points surrounding the one chosen can assist. The EOS 7D can register original AF point “Home Positions” and represent them automatically in both horizontal and vertical shooting positions. The EOS 7D also has an all-new Zone AF system, wherein one of five distinct focus zones can be chosen, particularly useful for off-center subjects. ONE-SHOT AF mode is ideal for static subjects — the camera rapidly selects the optimum focusing point, and the subject is instantly brought into focus. AI SERVO II AF mode is excellent for moving subjects; it precisely tracks subject movement across the wide AF coverage area, automatically shifting the active focusing point as required. AI FOCUS AF mode, which automatically switches between One Shot and AI Servo AF modes based on subject movement, is ideal for stop-and-go subjects. In addition, Canon Light Source detection AF automatically compensates the focus by taking into account artificial lighting. The new AF algorithms used for tracking performance in the EOS 7D camera are so responsive that AI Servo II AF can even be used when shooting with EF and EF-S Macro lenses at high magnification to help ensure that unpredictable moving subjects, like a flower in a breeze, retain sharp focus. No matter what mode chosen, the EOS 7D’s autofocus is fast, reliable and versatile. And with Canon’s Intelligent Viewfinder technology, chosen AF points can be displayed or hidden easily in the Intelligent Viewfinder. **78**

*“I have never seen sharper images from fast-moving sports. The new and improved AF system is easier to use, which makes photographing running children or sports faster. Having the choice of two registered AF points for vertical and horizontal shooting is a great bonus. I am always amazed, at the new functions that make shooting with my EOS 7D camera faster, easier and better. It delivers.”*



**Michele Celentano**

Explorer of Light

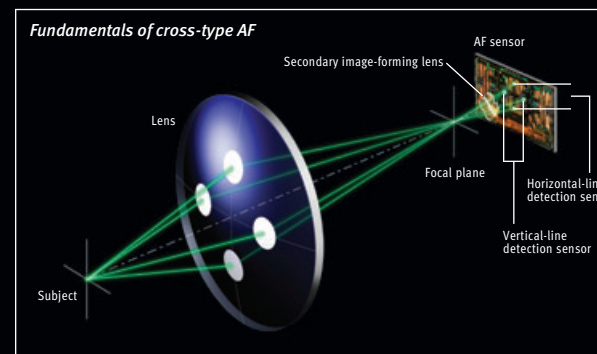

# Photography in the Wireless Age



## iFCL Metering System

The Canon EOS 7D features a new, multi-layer 63-zone iFCL (Intelligent Focus Color Luminance) Metering System to compliment the 19-point AF system. By taking into account the color and luminosity surrounding chosen AF point(s), this new system delivers an entirely new level of metering accuracy with an ideal balance of foreground and background information and natural color rendition no matter the composition. Canon's Evaluative metering mode, using an all-new metering algorithm, utilizes information from the EOS 7D's new AF system for more precise and consistent results. **78**



Integrated Speedlite  
TRANSMITTER

## Canon Speedlites

The EOS 7D is compatible with the current generation of Canon Speedlite flashes.

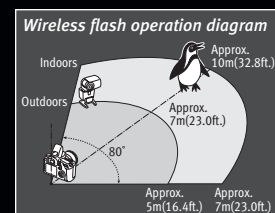

Canon Speedlites feature E-TTL II (Evaluative-Through-the-Lens) technology that incorporates distance information from compatible EF and EF-S lenses to help

ensure precise and accurate flash exposure control. Canon EX-series Speedlites provide simple wireless and automatic multiple-flash capabilities for advanced lighting solutions in a wide variety of shooting applications. The EOS 7D features an integrated Speedlite Transmitter with its built-in flash that allows the photographer to wirelessly control an unlimited number of EX-series Speedlites. **83 80**

## Wireless File Transmitter WFT-E5A

Designed for the EOS 7D, the WFT-E5A functions both as a wireless file transmitter and auxiliary grip. Now supporting 5.2 GHz 802.11a/b/g, it's the fastest, most versatile wireless transmitter around. The WFT-E5A allows the EOS 7D to wirelessly link up to 10 other WFT equipped cameras as a Master camera. When the Master is fired, the linked cameras are wirelessly triggered to fire in unison. The WFT-E5A allows full access to the camera's ports and maintains weather resistance and durability while offering reliable wired or wireless communication. As a camera grip, the WFT-E5A has the same buttons as Battery Grip BG-E7. **83**



EOS Movie  
FULL HD

## Full HD Video Capture

Compact and boasting some of the most advanced EOS video capturing features to date, the EOS 7D offers the enhanced image quality, smooth frame rates and adaptive exposure compensation necessary in a professional movie-making tool. The EOS 7D enables easy manual control of exposure, focus and Live View features and even allows for in-camera editing. The large CMOS sensor and compatibility with over 60 lenses provide a wealth of depth-of-field options. **128**

“Our minds have always worked in multiple media; cameras such as the EOS 7D now allow us to realize



our vision in an entirely new way.

With 24p 1080 video recording and a much-improved autofocus system, it allows the photo and cinema parts of Stillmotion to reach new heights. The form factor of these cameras makes them extremely versatile across a range of tools, whether it is being used with a steadycam, dolly, slider, tripod, or simply handheld. We can fully follow our vision with this little dream machine.”

**Stillmotion**



# Beauty in the Details



### 18.0 MEGA PIXELS CMOS 18.0 Megapixel CMOS Sensor and Dual DIGIC 4 Image Processors

The EOS 7D features a powerful, Canon designed, 18.0 Megapixel CMOS sensor that incorporates a number of significant refinements to enhance image capture. Thanks to advanced, in-house semiconductor manufacturing, the EOS 7D's sensor has more pixels than any other APS-C sized sensor in the Canon lineup, less digital noise, a higher ISO sensitivity (up to 12800 in H mode) plus a wider dynamic range. The EOS 7D employs a 14-bit converter to process the output of the CMOS sensor for smooth tonal transitions, natural gradations and striking color fidelity. The EOS 7D's Dual DIGIC 4 Image Processors help to ensure that images are captured, processed and saved with remarkable speed — up to 8 frames per second for approximately 126 consecutive Large/JPEGs and approximately 15 consecutive RAWs with a UDMA CF card. 

### ISO 6400 Extraordinary ISO Range

The low-noise performance of the CMOS sensor combined with the noise reduction capabilities of the Dual DIGIC 4 Image Processors allows the EOS 7D to have an exceptional ISO range: 100–6400 in standard mode, 50–12800 in extended range mode. This provides the photographer with many more shooting options in a wide range of real-world shooting situations — in particular, available-light shooting capabilities never before available with APS-C sensor size EOS SLRs. While the higher end of the camera's ISO range is important for low-light shooting, performance at the low end of the ISO scale is

just as important: A lower ISO setting is useful when shooting brightly lit scenes with fast lenses. 

### 63 ZONE Dual-Layer Metering Metering System

The EOS 7D features a new technology from Canon, the iFCL (Intelligent Focus Color Luminance) Metering System with a 63 zone dual-layer metering sensor to compliment the 19-point all cross-type AF system. This new system delivers an entirely new level of metering accuracy with an ideal balance of foreground and background information and natural color rendition no matter the composition. 

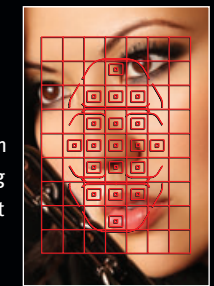

Metering zones

### Advanced 14-bit A/D Conversion

Whereas many digital cameras use 12-bit A/D converters, the EOS 7D employs superb 14-bit per channel converters to process the output of the imaging sensor. This means there are 16,384 distinct brightness steps from the darkest to brightest tone (vs. 4,096 previously) for smoother tonal transitions and more natural gradations. RAW images are recorded at the full 14 bits, and once processed will preserve the entire range of tones when opened in Photoshop's 16-bit color space. 

*“The improved dynamic range of the EOS 7D, combined with the increased resolution, allows me more freedom to capture images with more varied and complex light, and maintain both highlight and shadow detail. The 18.0 Megapixels allow for an amazing amount of detail and ability to crop to fit the various layouts that come up going from ad page to billboard to bus signs.”*

**Stephen Eastwood**  
Explorer of Light

# Power and Durability in a Small Package



## Rethought Button and Control Layout

The EOS 7D raises the ergonomics bar with refined curves, changes in the placement of buttons and elegant materials that make shooting both intuitive and fun. The EOS 7D's power switch, now located on the upper left of the camera, is separate from the Quick Control Dial switch. A dedicated button switches on the Quick Control screen, a JPEG/RAW button makes for quick switches in image quality settings, and the Live View/Movie mode lever starts, stops and switches between Movie and Live View modes. The Custom Control screen even allows the photographer to remap and rearrange the functions of most of the EOS 7D's buttons to customize the camera's features and precisely match their specific shooting style. Combined with an advanced coating, plus recessed controls, the EOS 7D is faster and easier to use than anything that came before it.



Power switch

## Built for the Elements

Canon's decades of camera-making experience mean nothing less than real-world performance and durability that is second to none. The EOS 7D is constructed of the highest quality materials, to exacting standards, to ensure unfettered performance at all times. For example, the shutter can shoot at speeds up to 1/8000 sec for up to 150,000 cycles; the chassis is built of lightweight and rigid magnesium, and the camera's seals are made to resist water and dust. This ensures the EOS 7D



Shutter unit

will be ready for anything and will remain comfortable in the hand even after a full day of use. With the optional Battery Grip BG-E7 nearly doubles the battery life of the EOS 7D, while offering advanced operability and seamless integration with the camera's design. Designed to accommodate one or two LP-E6 batteries, or AA batteries with battery magazine BGM-E6, the BG-E7 increases flexibility on the go. With a vertical shutter release button, plus AE lock and Multi-Function button, it makes vertical shooting a breeze. Made with the same grip coating and dust resistance as that on the EOS 7D's body, the BG-E7 is the perfect accessory for the EOS 7D. **81**

## High-resolution 3.0-inch Clear View II LCD Monitor

ClearView II

The EOS 7D features a brilliant 3.0-inch LCD monitor with approximately 920,000 dots for high-resolution

image and information display. It provides 100% image area coverage and a wide viewing angle of 160° (vertically and horizontally) with stunning brightness to ensure excellent viewing ability even in bright outdoor conditions. A specially engineered optical elastic resin filling the gap between the LCD panel and the outer reinforced glass protective cover reduces internal reflections, ensuring stunning display visibility and clarity. **81**

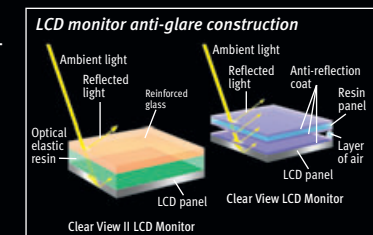

*"This little camera feels GREAT! The EOS 7D feels incredibly tight, compact and solid. My hands just*



*naturally wrap around it, and the controls*

*fall right where they should. It makes me want to shoot. Street-shooting. Casual candid. Things I normally wouldn't be drawn to. And my favorite thing is the lens conversion factor. It transforms my favorite lens, the incomparable 85mm/1.2, into an exquisite 135/1.2!"*

**Gregory Heisler**

Explorer of Light



# Beauty in Darkness, Beauty in Light



## 18.0 MEGA PIXELS CMOS 18.0 Megapixel CMOS Sensor

The EOS 7D features a powerful, Canon designed, 18.0 Megapixel CMOS sensor that captures a tremendous level of resolution with striking detail down to each individual pixel. With size to spare, it's easy to crop images or to make massive enlargements without concern of losing detail. A marvel of technical innovation, the EOS 7D's CMOS sensor incorporates a number of significant refinements: The EOS 7D's sensor has more pixels than any other APS-C sized sensor in the Canon lineup, with less digital noise, a higher ISO sensitivity, plus a wider dynamic range than before. The EOS 7D's CMOS sensor incorporates a unique on-chip noise reduction technology to deal with both fixed pattern and random noise. A new photodiode construction results in an improved photoelectric conversion rate, meaning faster and increased sensitivity at the pixel level. Finally, an infrared and a multi-layer low-pass filter are placed in front of the sensor to isolate and eliminate false colors, while retaining full detail. This low pass filter features a fluorine coating to reduce dust adhesion for less digital clean up. **176**

## EOS Movie FULL HD Advanced Video Capture

The EOS 7D's Movie mode combined with its compact size increases flexibility. Allowing for the full use of over 60 Canon EF and EF-S lenses, the photographer may take advantage of the EOS 7D's expansive range of ISO sensitivities and to exert full manual

control over exposure and depth-of-field. Full HD video is captured at 1920 x 1080 resolution at 24 (23.976), 25, or 30 (29.97) fps, for up to 4GB per clip. Other recording sizes include HD at 1280 x 780 resolution at 50/60 (59.94) fps or SD/VGA at 640 x 480 (50/60 fps). **126**

## DIGIC 4 Dual DIGIC 4 Image Processors

The EOS 7D's new Dual DIGIC 4 Image Processors ensure that images are captured, processed and saved with remarkable speed — up to 8.0 frames per second! Developed and produced to maximize performance for both the capture and recording stages of digital photography, Dual DIGIC 4 Image Processors work in concert with Canon CMOS sensor chips to dramatically enhance image quality and deliver a more intuitive, responsive camera. Optimized signal processing algorithms work with the multi-channel signal from the camera's sensor to deliver significantly speedier camera response. Live Face Detection AF, HD Video, Canon's amazing Auto Lighting Optimizer, Lens Peripheral Illumination Correction and more are all possible thanks to the speedy processing of the Dual DIGIC 4 Image Processors. **171**



Dual DIGIC 4 Image Processors

*"The strongest point for me is the fact that I can have a very small, compact camera that takes the full compliment of lenses, with built-in flash."*



*What sold me was the availability to switch quickly from color to B&W. You can very easily set up several custom settings, which is fantastic. One moment I'm shooting RAW stills, then I switch instantly to B&W to shoot HD video, and back to color for stills. It's very seamless and intuitive. This is a fantastic little jewel of a camera!"*

**Christopher Morris**

# EOS 60D

## *The Featured Professionals*

### **An EOS with Perspective**

With the new EOS 60D DSLR, Canon gives the photographer a powerful tool to foster creativity, with enhanced image quality and advanced features, such as automatic and in-camera technologies for improved ease-of-use. It features a new Canon APS-C sized 18.0 Megapixel CMOS sensor for tremendous image capture, Canon's exclusive DIGIC 4 Image Processor for finer detail and excellent color reproduction, and improved ISO capabilities from 100 – 6400 (expandable to 12800), for uncompromised shooting even in low-light situations. The EOS 60D also features an EOS first: A Vari-angle 3.0-inch Clear View LCD monitor for easy low- or high-angle viewing, even from the side or front of the camera. A new Multi-control Dial enables users to conveniently operate menus and enter settings with a simple touch, regardless of camera orientation. An improved viewfinder, a number of new in-camera creative options and filters, plus HDMI output for viewing images on an HDTV all make the EOS 60D invaluable for the professional photographer.



**Hanson  
Fong**  
Explorer of Light

### **Putting the System to Work**

Hanson Fong is recognized as one of the premier wedding photographers in the industry today. His work has been displayed in prestigious venues, such as the International Photography Hall of Fame and the Epcot Center. He has lectured at every major school of photography across America and his work has received high critical acclaim throughout the world. The tremendous versatility and solid dependability of the EOS System make it Fong's professional workhorse.



**Lewis  
Kemper**  
Explorer of Light

### **Dependability in the Field**

Lewis Kemper is a renowned outdoor photographer whose work is ubiquitous. His images have been seen in editorial and commercial usage in over 16 different countries and in print media ranging from national ads to book covers. Kemper is currently a contributing editor and columnist for *Outdoor Photographer* and *PC Photo*. For demanding outdoor shooting, EOS is Kemper's "go to" system for reduced size and weight without sacrificing professional features.





©2009 Hanson Fong. All Rights Reserved.

# A Perfect Companion



### Built-in Wireless Flash Transmitter

The EOS 60D even helps make elaborate lighting setups simple. It features an Integrated Speedlite Transmitter that can serve as a driver for a number of Speedlite flash units, making sophisticated lighting setups wireless and simple. 

### CMOS Image Sensor

The EOS 60D features a new, Canon-designed 18.0 Megapixel APS-C size CMOS Image Sensor that captures such a high level of resolution, it is easy to crop images for enlargement without concern of losing detail. A major factor in reducing noise, Canon's CMOS sensors assure that images shot at the highest sensitivity will be remarkably smooth.

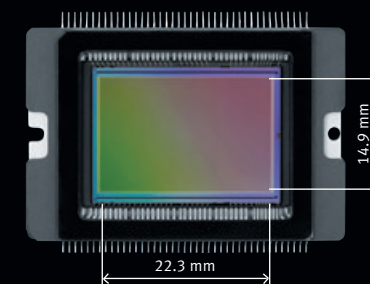

EOS 60D APS-C CMOS Sensor (actual size)

Canon's exclusive DIGIC 4 Image Processor ensures that images are captured, processed and saved with remarkable speed. The EOS 60D DSLR's new multiple aspect ratio control in Live View mode, in-camera RAW

image processing, creative filters, image resizing and provided S2 and S3 image-recording qualities are all possible thanks to the DIGIC 4 Image Processor. With dazzling results, the EOS 60D's DIGIC 4 Image Processor also works to capture and process data of images shot at 18.0 Megapixels at 5.3 fps, using 14-bit signal processing for excellent image gradation. The DIGIC 4 Processor is also responsible for enhanced Face Detection Live mode, Full HD video recording, Auto Lighting Optimizer and Lens Peripheral Optimization. 

### ISO Range

With a broad range of ISO settings, expandable up to 12800 with Custom Functions, the EOS 60D enables shooting in bright to dim light, capturing images with unparalleled fidelity and detail. With enhanced high-sensitivity optimization, subjects can be captured clearly and easily at high shutter speeds without flash, with minimized blur and noise. In bright scenes, especially exposures in daylight, optimal exposure can still be achieved with the low ISO 100 setting and a fully open wide-diameter lens, without the need for add-on neutral-density filters.

*"I love the new flip-out Vari-angle LCD! The flip-out LCD is something I've always wanted, especially when shooting weddings!"*

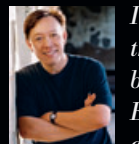

*I also love the accessibility of the EOS 60D's control dial. It is simple to use and easy to understand. This camera will have a serious impact on the average-to-professional photographer."*

### Hanson Fong

Explorer of Light



812-851-  
588-384  
597-488  
852-821  
714-538

The Lord is my Shepherd

Hanson

# No-Compromise Photography on the Move



## Resolution

The lightweight and compact EOS 60D captures phenomenal images, at resolutions up to 18.0 Megapixels, with the clarity and tonal range every photographer expects from their EOS Digital SLR, and provides image files capable of handling massive enlargements or significant crops. The EOS 60D ensures that image files recorded in myriad conditions halfway across the world are as robust as those recorded in the studio.

## Grid Focusing Screen

Like a number of professional Canon SLRs, the EOS 60D features interchangeable focusing screens including

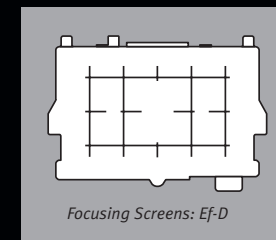

Focusing screen EF-D that superimposes grid lines over the image in the viewfinder, perfect for shooting architecture or landscapes, and in helping to frame and compose images. A Super-

Precision Matte screen (Focusing Screen EF-S), designed to assist photographers who manual focus Canon's f/2.8 and faster lenses is also available. 

## 3:2 Ratio Monitor

The Canon EOS 60D DSLR's amazing Vari-angle 3.0-inch Clear View LCD monitor has the same 3:2 ratio as the image to be recorded, allowing you to see your images larger and clearer, and enabling superior

composition whether the camera is held above, at or below eye level.

## Electronic Level

The EOS 60D sports an incredibly useful electronic horizontal level meter, displayed in the viewfinder, as well as on the LCD panel and on the monitor. Not only is this helpful when framing elaborate compositions, it's particularly useful in maintaining a discrete presence in places where a camera mounted to a large tripod may draw unwanted attention to the photographer. 

Electronic level display in the viewfinder and LCD panel

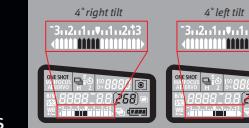

Electronic level display



*“My favorite features in the EOS 60D are the Vari-angle LCD, really convenient for close-up, low-angle and crowd photography and allows me to com-*



*pose with ease under all circumstances, and the built-in electronic level. Many times I forget to bring a bubble level, and this feature makes it obsolete. No more sloped horizons! And with 18 Megapixels, I can crop my pictures and still make large, beautiful prints without sacrificing quality! This camera is a definite winner!”*

**Lewis Kemper**

Explorer of Light

# Technology that Sets the Professional Standard



©2009 Vincent Isola

## Full-Frame Canon CMOS Sensors

The Canon-manufactured full-frame CMOS sensor delivers

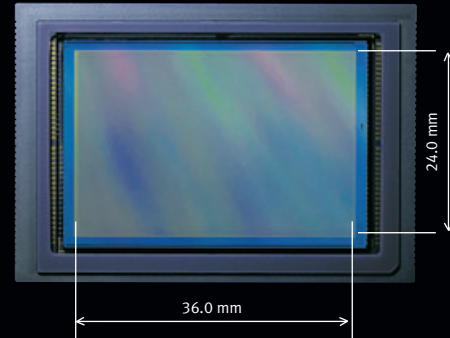

EOS-1Ds Mark III Full-Frame CMOS Sensor (Actual Size)

professional performance with digital convenience. EOS digital SLR cameras with full-frame sensors, like the EOS-1Ds Mark III and EOS 5D Mark II, do not require a focal length conversion factor common to other digital SLR cameras on the market. Full-frame sensors provide greater control over depth-of-field, which helps to create beautiful background blur, perfect for portraits. The large sensor area also makes possible a marked reduction in noise levels at all ISO values. When combined with high resolution and smooth gradation from highlights to shadows, Canon digital SLR cameras with full-frame sensors produce images that rival those taken with professional medium-format and large-format film and

occur with great speed. To combat both fixed pattern and random digital noise, Canon CMOS sensors incorporate a unique on-chip noise reduction technology. In addition, a multilayer low-pass filter is placed in front of the sensor to isolate false colors that the sensor may detect. Then, Canon's own DIGIC Image Processor analyzes and renders the image to help eliminate those colors while retaining full detail. A mainstay of the entire EOS line, Canon CMOS sensors deliver outstanding resolution and signal purity, making them ideal for the most critical applications.

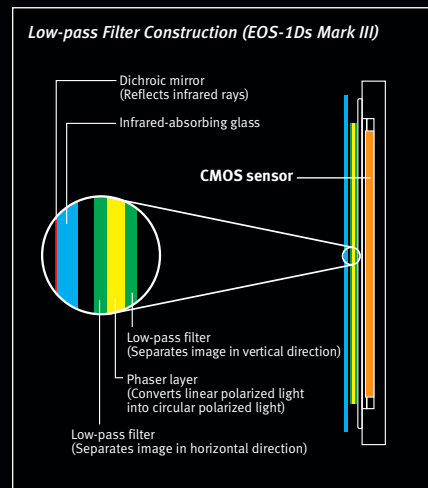
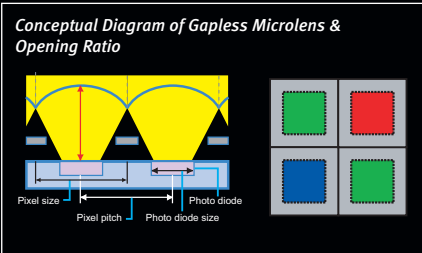
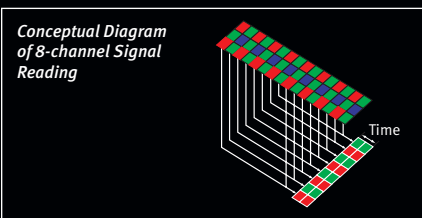

## Spectacular Image Quality, Second to None

### Canon CMOS Sensors

Taking advantage of its own proprietary technological and manufacturing capabilities, Canon develops and produces its own CMOS sensors for the entire EOS line of digital SLRs. Unlike CCD sensors, CMOS sensors convert and amplify signals before they are transferred to the image processor, enabling them to produce exceptionally clean image data and reduce power consumption by as much as 90%. Thanks to multi-channel signal paths that dramatically improve camera responsiveness, data transfers through CMOS sensors



When using the same lens with different cameras, the angle-of-view varies depending on the sensor size.

digital cameras. For maximum control and dependable performance Canon full-frame digital SLR cameras are simply unparalleled.

### DIGIC Processors

Developed in-house to maximize performance between the capturing and recording stages of digital photography, Canon DIGIC Image Processors use advanced signal processing technologies to dramatically enhance image



quality and deliver a more intuitive, responsive camera. The DIGIC Image Processors work in concert with Canon CMOS sensors to achieve even higher levels of performance in every facet of the image capture process. Signal processing algorithms work with the multi-channel signal from the sensor and the high-speed DDR-SDRAM buffer to deliver significantly improved camera response. With low power consumption, battery life is extended. Color reproduction, noise reduction in low light situations and reproduction of fine detail are all significantly improved. In addition, the latest DIGIC 4 Image Processor speed up all computation-intensive operations, dramatically improving camera responsiveness and making possible a number of advanced features. Canon technologies like Face Detection Live mode, Full HD and HD movie recording, Lens Peripheral Illumination Correction and Auto Lighting Optimizer are all possible thanks to the power afforded by the amazing DIGIC Image Processor.

### Wide ISO Ranges

EOS SLR cameras feature an extensive ISO range for immense flexibility in diverse photographic situations. For example, the EOS-1D Mark IV features the breathtaking ISO range of

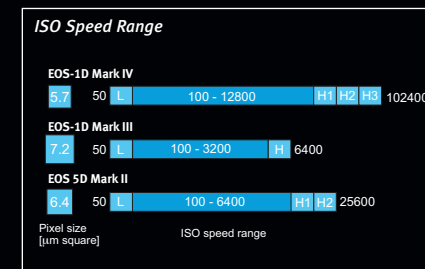

100-12800 (with extended range options of L: 50, H1: 25600, H2: 51200, H3: 102400)!\* This greatly expanded capability provides a previously unavailable range of real-world shooting options, especially in available-light or dim situations. Also significant is the camera's improved low ISO range performance. The camera's CMOS sensor features advancements that make it possible to operate with reduced electrical charge saturation. This improves imaging performance at the low end of the ISO scale, which can be highly useful when shooting high contrast scenes with fast (e.g., f/1.4) lenses. Blown highlights can be avoided, and photographers can use wider apertures to control depth-of-field in ways not possible at higher ISO settings. And at higher ISO settings where one might expect to see an increase in digital noise, the renowned Canon CMOS sensor and noise reduction system work together to ensure superb image quality. Accordingly, even the most critical photographers can use their EOS SLR camera with confidence, no matter the light.

\*Standard output sensitivity. Recommended exposure index.

### 14-Bit A/D Conversion

EOS digital SLR cameras employ 14-bit converters to process the output of the imaging sensor. Compared to the 12-bit converters used in most digital cameras, the Canon

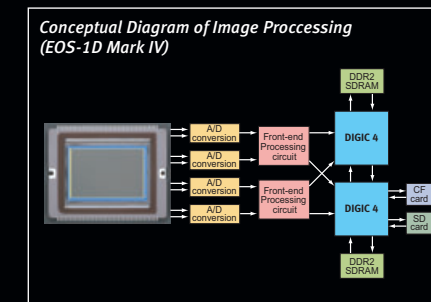

design delivers more lifelike, robust colors and tones. RAW images are recorded at 14 bits so that processed 16-bit TIFF images contain the full range of tonal values captured by the sensor. With every click of the shutter each recorded color channel provides 16,384 separate steps of brightness, from darkest to lightest. This means smoother tonal transitions, more natural gradations, and superb color fidelity, all in-camera.

### Highlight Tone Priority

Canon's Highlight Tone Priority feature extends the dynamic range of highlights by about one stop and improves gradation within highlight areas. By expanding the range from the correct exposure level (18% gray) to the maximum allowable highlight level, the gradation from the grays to the highlights becomes smoother and loss in highlight detail is minimized.

Highlight Tone Priority: ON

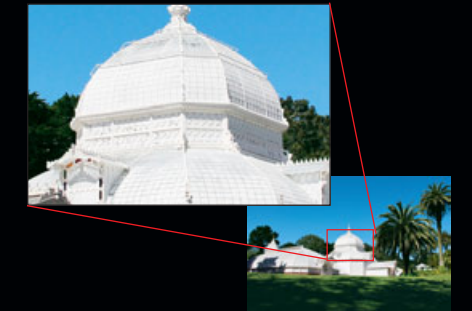

Highlight Tone Priority: OFF



**Auto Lighting Optimizer**

One of Canon's newest technologies, the Auto Lighting Optimizer automatically corrects image exposure to help ensure accurate brightness and contrast. It can actually brighten areas of the composition while maintaining highlight details and accurate exposure in others, or darken areas of composition while

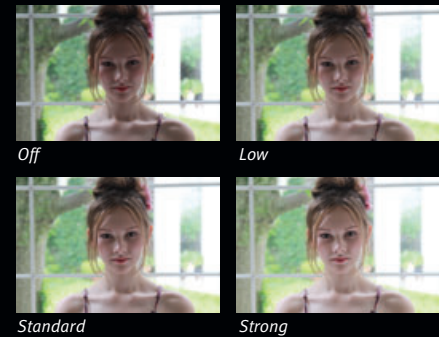

maintaining brightness and shadow details in others. This remarkable feature is available as both an automatic feature in Full Auto and Creative Auto shooting modes, and can be used and fine-tuned in other modes. The Canon Auto Lighting Optimizer ensures beautifully exposed images that require little to no post-production work.

**Lens Peripheral Illumination Correction**

A number of Canon's newer EOS digital cameras feature Canon's Lens Peripheral Illumination Correction. Taking into account the lens in

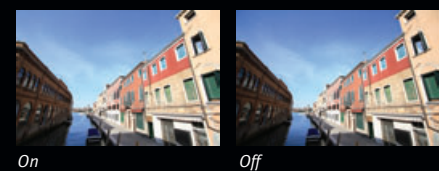

use, this feature automatically brightens the light level at the four corners of the composition where light falloff may have occurred. Peripheral illumination characteristics and correction data are detected automatically on a number of Canon lenses and can be entered manually through Canon's EOS Utility software. This function can be applied when shooting to JPEG images, and in post-processing with RAW images.

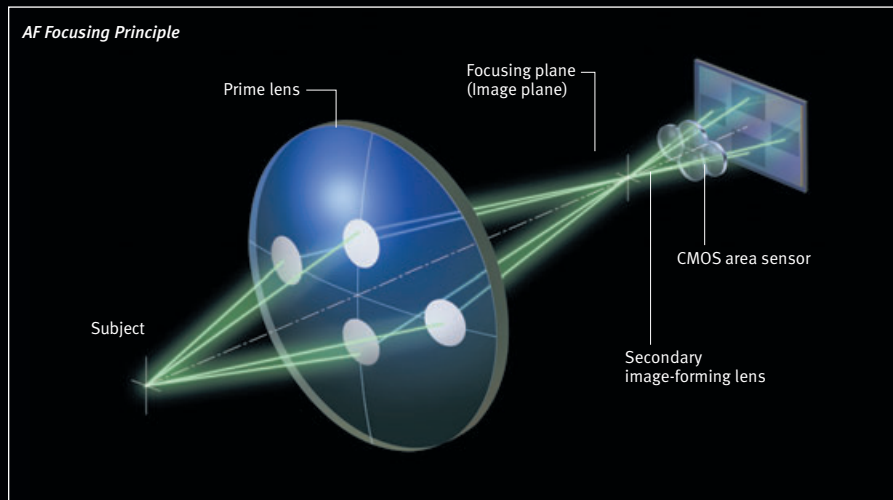

**Exceptional, Dependable Precision Performance**

**High-Speed Shooting**

EOS SLR cameras have always been associated with speedy operation. And today's cameras do not disappoint, with the fastest EOS cameras employing dual DIGIC 4 Processors and offering 10 frames-per-second continuous shooting, up to 28 RAW files or 121 full-resolution JPEGs. The EOS-1D Mark IV has a minimum lag time of 40 msec, an 80 msec viewfinder blackout time (at speeds of 1/60th and above), shutter speeds up to 1/8000 sec., and a flash sync as fast as 1/300 sec. when used with Canon Speedlites. Dedicated, quiet low-speed modes and self-timers add further to speed.

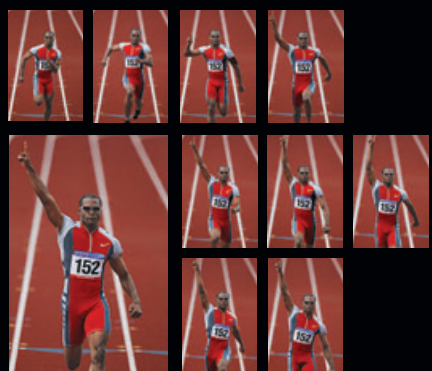

**10 Frames Per Sec** EOS-1D Mark IV features an improved AI Servo AF focus tracking and 10.0 fps high-speed continuous shooting, for sharp, detailed photographs in every shot.

**AF Technology**

The best autofocus systems combine accuracy, speed and reliability. And for that combination, there's nothing like the cutting edge AF systems



found in EOS SLRs. The EOS-1 series even features its own dedicated CPU to handle AF processing. Selected EOS SLR cameras use an extraordinary 45-point high-density Area AF system that provides a large AF coverage area, but also the greatest range of control over focusing point selection. The focusing point can be chosen automatically by the camera (based on high-speed microcomputer analysis of image content) or manually by the

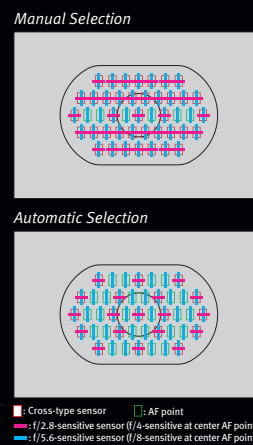

AF point display sample for 19-point automatic selection AF and AI Servo AF (EOS 7D)

user. Select EOS cameras feature up to 39 cross-type AF points that provide both vertical and horizontal sensitivity, guaranteeing the same optimal performance no matter the camera's orientation. Focusing modes include single point AF, Spot AF (which narrows the area used by the AF line sensor, helping to reduce detection errors

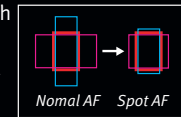

to occur from near and far objects when aiming at small subjects), and AF point expansion, where AF points surrounding the one chosen can assist when the subject moves or becomes unfocused.

To maintain focus, advanced Canon focus-tracking technology helps maintain the accuracy

**Autofocus Technology (EOS-1D Mark IV)**

- NUMBER OF AF POINTS (C.Fn III-10)**
  - 45-point
  - 19-point
  - 11-point
  - Inner 9-point
  - Outer 9-point
- EXAMPLE OF AF EXPANSION**
  - With single AF point selected
  - With two AF points selected
  - With right AF point selected
- AF POINT AT THE HORIZONTAL/VERTICAL ORIENTATION (C.Fn III-16-1)**
  - Automatic AF point switching to registered AF point when camera's orientation is changed.

of the initial AF setting, no matter the light source or how fast the subject is moving. EOS cameras feature a number of dedicated autofocus modes designed to enhance reliability in a variety of dynamic shooting situations. ONE-SHOT AF mode is ideal for static subjects — the camera rapidly selects the optimum focusing point, and the subject is instantly brought into focus even if it is off-center. AI SERVO AF/AI SERVO II AF mode is excellent for moving subjects. Aided by a highly intelligent predictive focusing algorithm, it precisely tracks subject movement across the wide AF coverage area, automatically shifting the active focusing point vertically and horizontally as required. AI FOCUS AF mode, in which the camera automatically decides between ONE-SHOT and AI SERVO AF modes based on subject movement, is ideal for shooting unpredictable subjects. AI SERVO II AF mode, a new feature found on the EOS-1D Mark IV and EOS 7D, uses new algorithms for sophisticated predictive focus tracking performance, even when shooting subjects with erratic movement. Even difficult, high-magnification subjects, such as a flower in a breeze are captured accurately with a Canon Macro lens using these new tracking algorithms.

**63-Zone TTL Metering**

Canon EOS DSLRs incorporate advanced exposure control systems, offering photographers exceptionally precise AE (auto exposure) with a wide range of metering options. Full-frame Evaluative metering incorporates the camera's multi-zone sensor read-

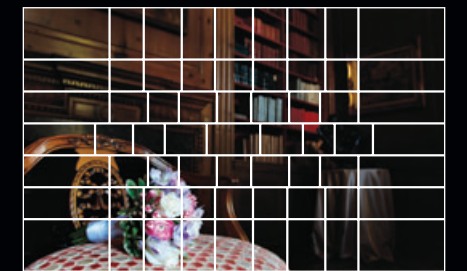
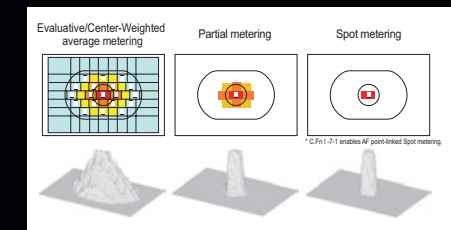

ing with specific focusing point data. The onboard microcomputer compares input from all zones and calculates optimum exposure. While Evaluative metering helps to assure excellent results in even the most challenging lighting situations, advanced photographers can choose from among several other metering options more appropriate for the particulars of the shot. Center-weighted metering is available for those who prefer a more traditional pattern. Partial metering limits readings to sensor zones in the center of the image area, giving the photographer more area-specific control. Spot readings can be taken at the center of the frame area or, with some models, linked to an AF point. With certain EOS cameras, up to eight separate Spot meter readings can be recorded and averaged.

**iFCL Metering**

Canon's iFCL (Intelligent Focus Color Luminance) 63-zone Dual-layer metering system incorporates the color wavelength surrounding the chosen focus point to help ensure more natural color rendition. By taking into account the color and luminosity surrounding chosen AF point(s), iFCL metering delivers a higher level of metering accuracy with an ideal balance of foreground and background information and natural color rendition no matter the composition. Canon's Evaluative metering mode, using an all-new metering algorithm, utilizes informa-

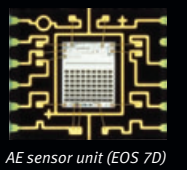
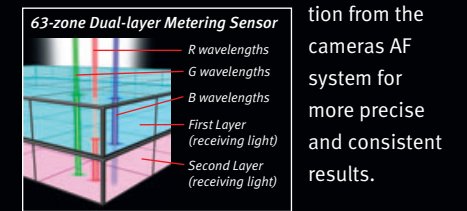

AE sensor unit (EOS 7D)

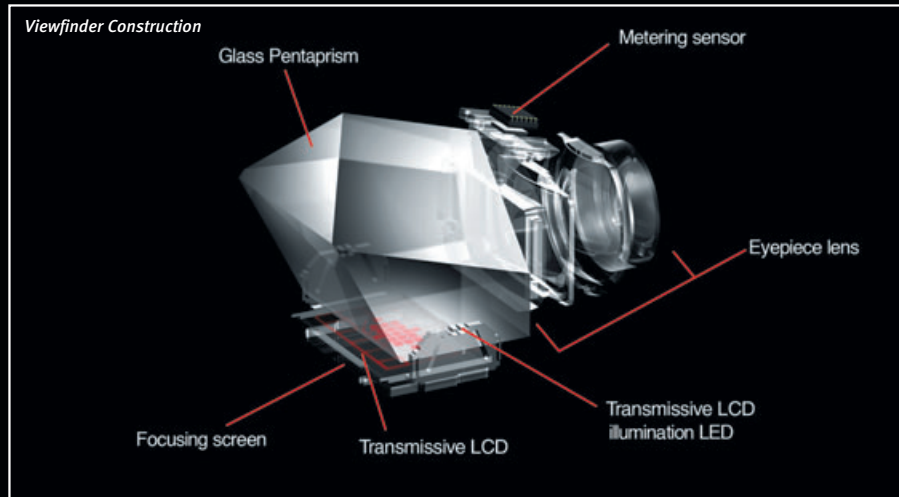

**Bright, High Magnification Viewfinders**

No matter the camera's specifications, a clear, bright viewfinder is the photographer's first tool for great images. Canon innovates with their viewfinders, especially with the viewfinders in the EOS-1Ds Mark III, EOS-1D Mark IV and EOS 7D, by offering approx. 100% viewfinder coverage. Several EOS SLRs have a larger pentaprism for higher viewfinder magnification, delivering the best view of any EOS digital camera to date. All EOS digital SLR cameras offer dioptic correction and several EOS SLRs have a number of different viewfinder accessories, including up to 11 different focus screens available for most any application.



**Intelligent Viewfinder**

A new Canon technology, the Intelligent Viewfinder in the EOS 7D, is a transparent LCD in the viewfinder that superimposes a variety of shooting information at the push of a button. Whereas with other EOS cameras' viewfinders the representation of AF points and metering areas are static, with an Intelligent Viewfinder, they can be displayed, adjusted, or hidden, in-camera, with ease. The Intelligent Viewfinder includes a Grid Display and in Spot Metering mode, the specific area metered is shown. For focusing, the 19 AF points are displayed together, individually, or in groupings corresponding to the focusing mode selected. A Spot metering circle and Grid Display can also be selected. The Intelligent Viewfinder can also display the



Dual Axis Electronic Level, which provides indicators to help the photographer achieve a horizontally level and non-pitched camera position when required. A Hide All mode turns off all superimposed displays, providing a clean, unimpeded view when desired. When shooting in low light, the LCD can be illuminated to more clearly show critical viewfinder information. All this with negligible effect on perceived brightness and clarity. The eyepiece lens is made of high-refraction glass to control aberrations and produce a clearer image. Overall brightness and acuity are further enhanced by the use of a special anti-reflective coating in the camera's prism.

**Focusing Screens**

Several EOS SLRs have available a number of different viewfinder accessories, including up to 11 different focus screens for most any application. Laser Matte focusing screens make it easier to focus manually and provide natural looking background blur, or "bokeh" when shooting with shallow depth of field. Super-Precision Matte screen (Focusing Screen Eg-S), are designed to assist photographers who manually focus Canon's f/2.8 and faster lenses.

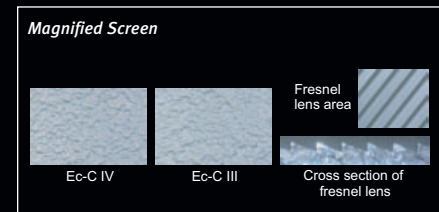

Intelligent View Finder (EOS 7D)

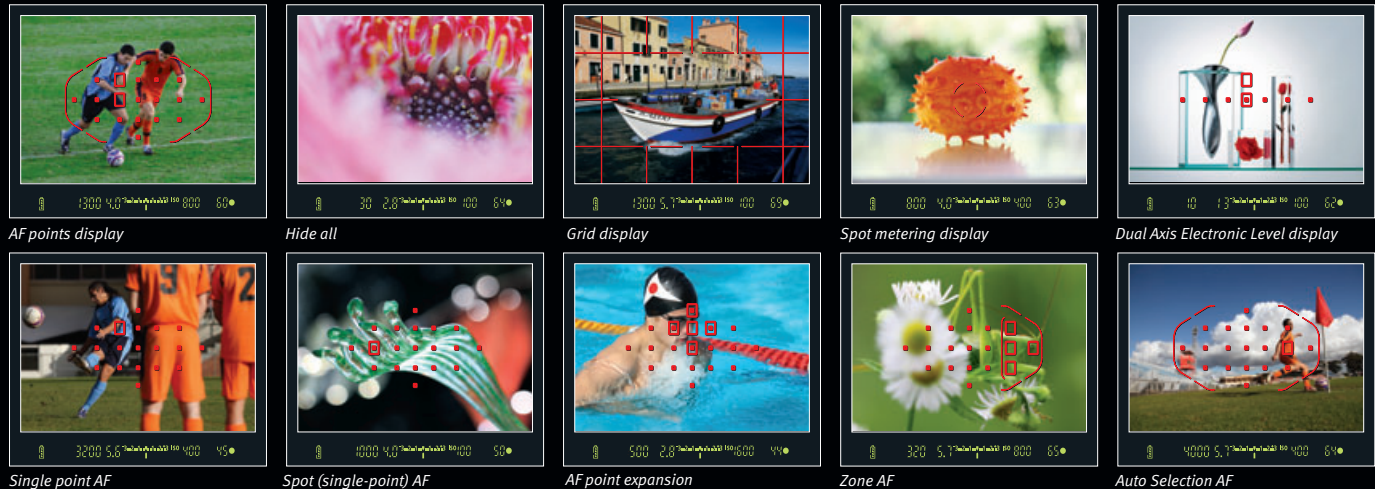

Grid focusing screens superimpose grid lines over the image in the viewfinder, making architecture and landscape photography composition simpler. Blackout screens for different aspect ratios, such as square and 4x5 are available for the EOS-1 series.

**EOS Integrated Cleaning System**

Canon has designed an Integrated Cleaning System with a Self Cleaning Sensor Unit customized to the specifications and performance characteristics of each EOS digital SLR camera. The integrated Cleaning System helps combat stray dust that can enter the camera when changing a lens or when out in the field. The front surface of the sensor's IR-cut/Low-pass filter cleans itself automatically with ultrasonic vibrations every time the camera is turned on or off. Removed dust adheres to material around the filter to help it stay off. With DPP software, dust missed by the cleaning unit can be captured by Canon's Dust Delete Data Detection and can be erased from the image file.



**Rugged, Reliable Construction**

The look and feel of quality and reliability one feels when handling an EOS SLR is the result of decades of camera-making experience. This experience translates to real-world performance and durability second to none, throughout the EOS line. The EOS-1D class of professional SLR cameras, for example, feature bodies made of coated cast magnesium



EOS-1Ds Mark III Magnesium-alloy Body

alloy, which, while light in weight, deliver outstanding strength, rigidity and electromagnetic shielding. Furthermore, each body is extensively gasketed and sealed, at 76 spots around the camera making them exceptionally water and dust-resistant. These are truly cameras built to take on the world's harshest shooting conditions.

**Heavy-Duty Shutter**

EOS DSLRs' shutter units are remarkably durable, with the top models boasting a 300,000-cycle rating. To attain this level of ruggedness, surface finish and heating processes in manufacturing have been developed specifically to extend service life. To increase stability and shutter precision, a PR (Photo Reflector) is employed to detect the slit-passing time. For the X-sync contact, the mechanical contact has been eliminated to prevent contact scorching and wear. By employing PR signals for the electronic X-sync contact (a semiconductor switch), reliability is improved. By optimizing the sync timing, an X-sync speed of up to 1/300 second is possible with certain EX-series Speedlite/SLR combinations.



Shutter Unit

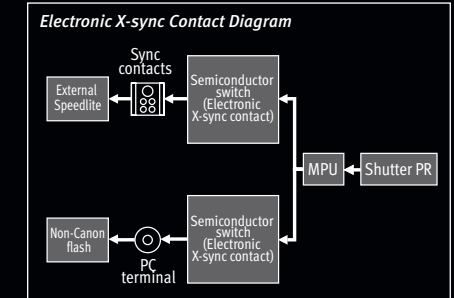

**Refined, Innovative Professional Features**

**Clear View, and Clear View II screens**

Canon EOS SLRs feature Clear View and Clear View II LCD displays. Dense with pixels, they provide an amazing level of clarity and sharpness

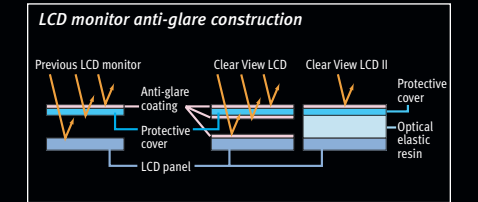

with an extraordinary angle of view. Useful not only to confirm focus and composition, or to access camera settings like ISO, metering mode, AF Point selection and flash options, Canon Clear View screens offer such a clear combination of information and detail that composing and shooting in Live View mode is simply a pleasure. Many EOS Models feature a tempered glass protective cover with an optical elastic resin filling between the actual LCD and glass cover that minimize internal reflections and improve visibility in bright viewing situations. During image playback, pressing the illumination button displays an LCD brightness screen, so brightness can be adjusted quickly and easily.

**Vari-Angle Clear View LCD**

The EOS 60D features a high resolution, flip-out Vari-angle Clear View LCD monitor for shooting at a variety of angles. By easily switching between low and high angles, these new LCDs freely enable angle adjustments even if the camera is mounted on a tripod or has a battery grip attached. The display can even be positioned to face forward, directly at the subject (the display automatically flips to show the image right side up).

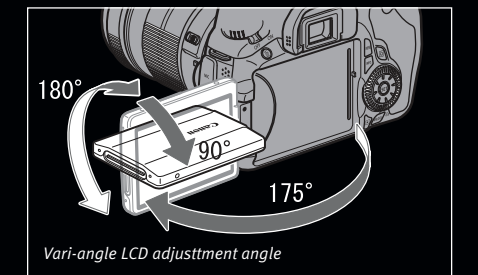

## Live View

Live View, where the photographer can compose and shoot directly from the camera's LCD is an indispensable feature for creative photography in any number of situations.

It enables the photographer to zoom in and navigate the composition 5x or 10x normal size, while enabling critical focus and allowing more attention to detail. Users can even choose a grid overlay, perfect for architectural photography. In Live View Face Detection mode, the camera detects the human face automatically and focuses with contrast AF. If multiple faces are detected, the largest face closest to the center is chosen automatically. Alternative faces can be selected via the camera's Multicontroller.

### LiveView MODE



Live View Function enabled



With 10x magnification

## Remote Live View

Remote Live View enables photographers to compose and control their images, from a computer, live. Controlled through Canon's EOS Utility software. The camera can be connected directly through a USB 2.0 Cable, or wirelessly with a Wireless File Transmitter attached. With a WFT and an FTP server, wireless remote live view shooting is possible over the Internet, making it possible to setup, shoot and save from a remote location. Meanwhile, through an Internet browser, the camera's Live View image can be seen, settings can be confirmed and changed, shots can be taken and images can be recorded on the camera and computer simultaneously.



## Electronic Level Sensors

Among the newest and most useful features developed by Canon, the brilliant Dual Axis Electronic Level display, available on the EOS 7D, aids in achieving perfectly oriented

shots. Visible in the viewfinder or on the camera's LCD, in both Live View mode or as a standalone, and capable of displaying both roll and pitch in 1° increments, the Dual Axis Electronic Level Sensor is invaluable for architecture, macro photography, video, or any situation where critical composition is important.



Electronic level display

## Picture Styles

EOS digital SLRs provide the experienced professional photographer with myriad features and settings, controlling every imaginable aspect of image appearance. The ability to make bold or subtle adjustments in color and contrast, for example, gives the photographer a wide palette for expression. Canon's ingenious Picture Style feature streamlines the process of making all of the camera settings needed to achieve a particular look. It provides a number of intuitive presets, including standard, neutral and landscape, that enable the photographer to make optimal choices based simply on the type of shooting. These presets can be used in much the same way one would use different types of film, and more can be created using Canon's included Picture Style Editor Software. Individual camera settings, such as sharpening, contrast, color tone, and saturation, can be overridden if required.



Picture Style

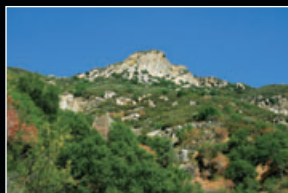

Picture Style: Landscape

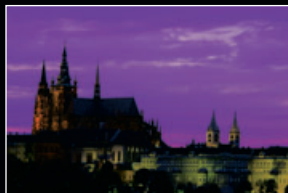

Picture Style File: Twilight  
(Extended Function, online support only)

functions to suit their own shooting style, or to optimize camera performance for specific subjects, shooting

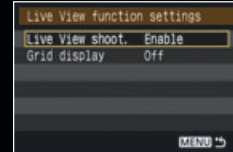

Live View Function settings

conditions or a signature style. Whether customizing a shutter speed range, specifying the parameters of bracketing, selecting a specific area of focusing points, setting the color balance in accordance with an upcoming locale, or preparing to hand the camera over to an assistant, photographers literally have hundreds of choices in how they customize their EOS digital SLR's operation.

## Versatile Recording Options (RAW+JPEG)

Often described as "digital negatives," RAW images contain unprocessed, uncompressed image data as captured by the sensor and, with post-processing, they yield the highest image quality possible from a DSLR. They are also perfect files for archives or for when the final application of the image is undetermined. While professionals and advanced amateurs will often prefer to shoot in RAW mode, JPEG images take up significantly less storage space and are often more immediately pleasing to the eye. With Canon EOS DSLR cameras, it's simple to capture images in a number of RAW or JPEG modes depending on the camera's sensor, as well as record numerous combinations of RAW and JPEG images simultaneously. And models like the EOS 60D can process RAW files in-camera, delivering JPEGs based on the shots original parameters, or with changes as specified by the photographer. This makes it easy to experiment with Canon Creative Filters, simulating grainy black and white photography, soft focus, toy cameras, even a Miniature Effect, with no effect on the original RAW file.

## UDMA Capability

The EOS-1D Mark IV, EOS-1Ds Mark III, EOS 5D Mark II and EOS 7D all fully support the UDMA (Ultra Direct Memory Access) Mode 6 standard. With UDMA CF cards, data write/read operations are significantly accelerated.

## Expansive, Versatile System Design

### Advanced Flash Control With EX Speedlites

Thanks to the extraordinary exposure control technology Canon has created, flash photography with EOS Systems is both simple yet sophisticated. E-TTL II autoflash systems work in combination with the camera's multi-zone metering sensor to help take the guesswork out of flash photography. The camera performs instantaneous calculations based on readings from the preflash, ambient lighting conditions and assessment of subject location to determine the optimum flash output and exposure settings. With E-TTL II, the calculations also incorporate distance information from compatible EF lenses, enabling the system to better handle dark, light and highly reflective subjects. Resulting images can have a virtually perfect balance between ambient light and flash illumination, even in complicated lighting situations and compositions.

### Built-In Speedlite Wireless Transmitter

With Speedlite flashes and newer EOS SLRs with Integrated Speedlite Transmitters built in, the photographer can set up simple, automatic unlimited Speedlites for a bona fide wireless studio. Using wireless flash, up to three groups (for main, fill and background) of flash units can be set up for comprehensive control of lighting. Speedlite slave units can be assigned to one of three groups, with adjustable output ratios from 8:1 to 1:1 or vice-versa, with the output of the third group adjustable through flash exposure compensation. Superb results are simple thanks to the E-TTL/E-TTL II autoflash system which controls the total flash output to ensure consistently correct exposures.

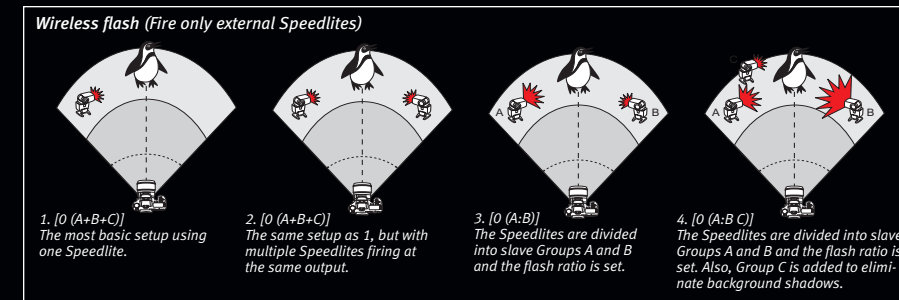

## Wireless File Transmitters

As quickly as the digital SLR has become commonplace in the hands of professional photographers and enthusiasts alike, so too has wireless communication between the SLR and external components. The EOS series has a number of dedicated Wireless File Transmitters that keep the camera connected to the wireless world, simply, with tremendous speed. Whether connected through a port on the side of the camera, or incorporated into a camera-integrated design, Canon Wireless Transmitters can connect and maintain two-way communication with computers and handheld devices. Canon's wireless Transmitters can quickly connect to Local Area Networks (LANs) up to 500 feet away and connect and upload to FTP (File Transfer Protocol) or dedicated WFT (Wireless File Transfer) servers. In HTTP mode, up to three separate computers, anywhere in the world, can access a camera's memory card with the WFT using a standard web browser (Microsoft Internet Explorer™, Apple Safari™, etc.). Images can be selected from the browser window and dragged onto a computer's desktop or to a folder, copying the full file to the computer. EOS Utility connectivity allows the photographer to connect a single camera to a computer for advanced two-way communication. WFT controllers can also connect through USB or Bluetooth to GPS units, and have coordinates, altitude and time code written to each image's shooting (or EXIF) data. External hard drives can be attached for direct recording or backup. Plus, select WFT models can be used as remote control receivers, allowing for wireless shooting and control, from a range of web-enabled handheld devices — even iPhones and the iPod Touch.

## Camera Linking

A sophisticated feature available thanks to Canon's WFT transmitters WFT-E2 II A, WFT-E4 II A and WFT-E5A, Camera Linking makes it possible for up to 10 cameras to shoot the same subject simultaneously, from different angles. Without a Wireless Access Point, up to 10 cameras can be connected and set up to take a shot the instant the shutter is released on the Master (main) camera. With an effective distance of 150 meters, this linked shooting is invaluable for the best possible capture of sports, news and wildlife and other quickly moving subjects that can be shot from a number of angles.

## Dual Card Slots With Multiple Recording Options And File Management Capabilities

The EOS-1Ds Mark III and EOS-1D Mark IV come equipped with two card slots, one for CompactFlash (CF) and one for Secure Digital (SD) Memory cards. The cameras can be set up to record images on either card for maximum storage capacity, or, for extra security, the same image can be recorded simultaneously on both cards. The card slot cover release knob is designed for easy operation, even if the photographer is wearing gloves. With both card slots easily accessed it's simple to change cards on the go knowing that, with multiple cards, storage capacity and file security is virtually endless.

## Smart Battery Packs and Chargers

The comprehensive sophistication of Canon's EOS digital camera line means intelligent batteries and chargers. From the batteries that power the Rebel series all the way through the flagship "1" series, Canon's Lithium-Ion batteries are small, lightweight, powerful and intelligent. The EOS-1 series can display Power source type, remaining capacity in icon or 1% numeric increments, shots taken since battery charged, whether battery calibration is needed and even when the battery has reached the end of its useful life. This information can be viewed with the [Battery info.] menu. An IC chip in the battery tracks use, displaying battery information upon communication with the camera. Other models display battery life as an icon both in the viewfinder and on the camera's LCD.

# The Perfect Complement to Your EOS System

## PowerShot

With shared EOS technologies like Genuine Canon optics, Optical Image Stabilizer, DIGIC Image Processor, and a familiar user interface, it's easy to transition seamlessly between an EOS SLR and a PowerShot compact camera. They're the perfect complement to each other.



### HS SYSTEM

The superb performance of the PowerShot G12 and S95 is in no small part thanks to the HS SYSTEM from Canon. The combination of a powerful 10.0 Megapixel CCD sensor and



the brilliant DIGIC 4 Image Processor, along with the fast lenses (f/2.8 on the G12 and f/2.0 on the S95) and the Canon Optical Image Stabilizer, ensure

enhanced performance. It delivers lower noise images even at higher ISOs, an increase in dynamic range, less blurring, less use of flash and more confidence to shoot in dimly lit situations.

### Bright Lenses with OIS

The PowerShot G12 and S95 come equipped with some of the most celebrated optics



offered by Canon. With maximum apertures, fast lenses (f/2.8 on the G12 and f/2.0 on the S95), wide-angle zooms, (28 – 140mm on the G12 and 28 – 105mm on the S95) and the lens-based Optical Image Stabilizer (OIS), images are guaranteed to be sharp and crisp. Now, Canon takes it even further with Hybrid IS to work in unison with OIS to greatly reduce pitch and yaw during macro photography to produce impressive results no matter the subject.

### DIGIC 4

The Canon DIGIC 4 Image Processor iSAPS technology helps to ensure that image capture is completed quickly and easily, and that every image captured is as clear and sharp as can be. More powerful processing makes the recording of large, high resolution images faster and easier than ever before, while iSAPS technology enables high-speed AF and high-precision exposure and color processing, all in the blink of an eye.

### Enhanced Camera Operation

Features, like the 2.8-inch Vari-angle PureColor System LCD, found on the PowerShot G12, and the control ring found on the PowerShot S95, bring a new level of customization to the photographic process. With the G12's Vari-angle PureColor System LCD, it's simple to compose and shoot with the camera in almost any position, enhancing

composition choices and making shooting possible in more situations. With the G12's front dial and the S95's control ring dial, parameters like exposure, aperture, white balance, zoom and more can be accessed and set with a simple twist.

### RAW RAW Image Capture

Both the PowerShot G12 and S95 offer RAW image recording in addition to JPEG. Perfect for images that the photographer wishes to work with in post-production, RAW files are the equivalent of digital negatives, in that only the image data is recorded. With RAW image files, the photographer can alter aspects like color balance, sharpness, saturation and more, infinite times in post-production practically without image degradation.

### HD Video

The PowerShot G12 and S95 don't just take amazing photos, they're also exemplary versatile photographic tools that can shoot stunning stereo sound and video in 720p HD. Preserve almost any subject in stunning realism and then easily watch all recorded footage on an HDTV with the convenient HDMI output connector.



## PowerShot G12

### The Flagship of Brilliant Performance

The PowerShot G12 offers the power of EOS technology in compact design. The Canon HS SYSTEM – a combination of a 10.0 Megapixel sensor and DIGIC 4 Image Processor – and fast f/2.8 5x Optical Zoom lens, delivers stunning quality in unfavorable lighting. The G12 can also preserve footage in amazing 720p HD video with stereo sound and view all recorded material on the convenient 2.8-inch Vari-angle PureColor System LCD. And to enhance the creative control even further, a Front Dial brings easy access to customizable camera parameters (aperture, exposure and white balance) at a turn, and RAW + JPEG shooting modes that make this camera an incredibly flexible and versatile tool.



## PowerShot S95

### Pocketable Perfection

Packed with powerful technologies, the pocket-sized PowerShot S95 delivers phenomenal results. Its HS SYSTEM (a combination of a 10.0 Megapixel sensor and DIGIC 4 Image Processor), f/2.0 3.8x Optical Zoom lens, and wide ISO range (up to 12800) help ensure photos will come out steady and crisp in low light. Working in unison with Optical Image Stabilizer, the S95 provides even more stabilization with Hybrid IS to help prevent the blurring effect of pitch and yaw common during macro photography with handheld cameras. Recording 720p HD Video, the large 3.0-inch PureColor System LCD has true-to-life reproduction so your stills and video show up brilliantly. Lastly, the customizable control ring allows for easy access to shooting settings and its RAW + JPEG shooting modes make the S95 a tool for creative control.





# Great Images Start with Great Lenses



For many professional photographers, Canon EF Series lenses alone are reason enough to choose the EOS System. A venerable blend of world-class optics, microelectronics, and precision manufacturing technologies such as a new SWC (Subwavelength Structure Coating) lens coating for better light transmission and reduced flare, EF lenses are perfected in Canon's laboratories and proven in the field. Whatever, whenever and wherever you shoot, you can count on Canon EF lenses to deliver high quality imaging performance.



## Optical Image Stabilizer

Canon's Optical Image Stabilizer technology makes handheld photography possible in more low-light situations than ever before. When camera shake occurs using normal lenses without Optical Image Stabilizer technology, the image projected on the image sensor also shakes, often resulting in blurred images at slower shutter speeds. With Canon Image Stabilized lenses, a special group of lens elements automatically shifts position, compensating for the movement and stabilizing the image. This compensatory effect adds the equivalent of up to 4-stops (depending upon the lens), expanding a photographer's handheld options dramatically.

*With Optical IS in the lens, Canon can equip each IS lens with the stabilizer it needs for effective shake correction. Other systems are limited by how far they can move an image sensor, and as a result, their stabilization is less effective as telephoto lengths get longer. Also, Optical IS can be seen right in the viewfinder — impossible with some other stabilizer systems.*

## HYBRID IS Hybrid Image Stabilizer

During normal shooting situations, sudden camera movement in rotational camera angles can cause significant image blur. During macro or close-up photography however, the image blur caused by linear camera shake — when the camera

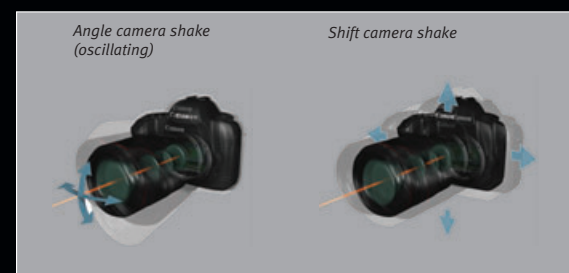

moves parallel to the subject — is more pronounced. Optical Image Stabilizer (OIS) is optimized to counteract rotational or angular camera shake and works well for most camera shooting situations. To help compensate for linear camera shake, a new acceleration sensor was required, the Hybrid Image Stabilizer.

Canon Hybrid Image Stabilizer technology, found in the **EF 100mm f/2.8L Macro IS USM**, employs a highly sophisticated algorithm combining the feedback of both the acceleration sensor and angular velocity sensor found in current OIS technology. This combination moves the image stabilizer lens elements, effectively compensating for both rotational and linear camera shake. Hybrid IS dramatically enhances the

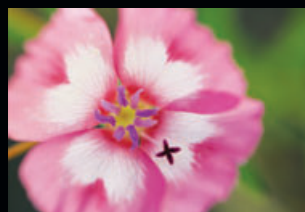

Taken with EF 100mm f/2.8L Macro IS USM with Hybrid Image Stabilizer

effects of Optical Image Stabilizer, especially during macro shooting. The incorporation of Hybrid IS allows users to more effectively compensate for camera shake during close-up shooting, marking a significant improvement in macro photography for portrait, nature or wedding shoots.

## Optical Image Stabilizer Mode 2 and Mode 3

The standard settings of the Optical Image Stabilizer are set so that it is most effective when photographing stationary subjects. However when panning with a moving subject is attempted (tracking of the subject horizontally or vertically), the shake-correction of the OIS may inadvertently over-compensate and interfere with framing. To help resolve this, Canon developed Optical Image Stabilizer Mode 2. In this mode, if you move the lens to follow a subject for a pre-determined time, the Optical Image Stabilizer does not correct for the intentional panning while continuing to correct any camera shake that's perpendicular to the panning motion. The result is a virtually smooth viewfinder image as you follow the moving subject. Optical Image Stabilizer Mode 3 activates IS only when the shutter button is fully pressed, allowing for easy panning of fast-moving subjects. Additionally, Mode 3 gives the equivalent effect of a shutter speed four stops faster, further positioning a user for action photography.

## Subwavelength and Fluorine Anti-smear Coatings

The Subwavelength Coating (SWC) is a new proprietary lens coating that helps control ghost and flare to a far greater degree than with earlier coating technologies. Utilizing SWC technology on large-curvature lens elements that are mainly found in wide-angle lenses, will significantly minimize the occurrence of ghosting and flare caused by reflected light in environments that have posed problems. SWC is used on the latest Canon wide-angle lens, EF 24mm f/1.4L II USM. The Fluorine anti-smear coating keeps soiling, smears and fingerprints to a minimum for easy cleaning.

## L-Series Lenses

Highly regarded among professional photographers, Canon L-Series lenses are distinguished by a bold red ring around the outer barrel. What makes them truly distinctive, however,

is their remarkable optical performance — the result of sophisticated Canon technologies such as Ultra-low Dispersion UD glass, fluorite and aspherical elements, and Super Spectra Coating.

## Diffraction Optics

Innovative Canon diffractive optics (DO) technology results in high-performance lenses that are more compact than traditional refractive designs. Conventional glass lens elements disperse incoming light, causing chromatic aberration. The Canon multilayer diffractive elements are constructed by bonding diffraction gratings to the surfaces of two or more lens elements. These elements are then combined to form a single multilayer DO element. The DO element's dispersion characteristics are designed to cancel chromatic aberrations at various wavelengths when combined with conventional glass optics. This results in outstanding reductions in "color fringing" — chromatic aberration — rivaling that of L-Series telephoto lenses. Canon DO technology is ideal for telephoto lens optics and makes possible significant size reduction while maintaining superb optical performance.



## Ultrasonic Motor

Canon developed the world's first lens-based Ultrasonic Motor (USM) to power the lens autofocus mechanism. Instead of large noisy drive trains powered by conventional

motors, Canon USM lenses drive the lens using the fine electronic vibrations created by piezoelectric ceramic elements. The focusing action of the lens is fast and quiet, with virtually instantaneous stops and starts. USM lenses also draw minimal power from the camera, ensuring longer battery life. Canon makes two types of Ultrasonic Motor lenses. Ring-type USM lenses, found in large aperture and super-telephoto designs, permit manual focusing without first switching out of the Auto mode. Micro USM designs bring the performance benefits of Canon USM technology to a wide assortment of affordable EF lenses.



Ring-type USM

## Specialty Lenses

### Super Telephoto Lenses

Distinguished by their white color and seen at major sporting events around the world, Canon's powerful EF Super Telephotos are ideal for getting up-close detail from afar. The latest additions to the EF Lenses line-up, the completely redesigned **EF 400mm f/2.8L IS II USM** and **EF 300mm f/2.8L IS II USM** feature improved durability and water resistance, new Optical Image Stabilizer algorithms and modes for up to 4-stops of shake correction, and magnesium alloy components that significantly reduce the weight and improve the usability from the previous versions while retaining strength. They both feature two fluorite lens elements that reduce chromatic aberration for outstanding optical performance. They are also compatible with the newly redesigned Extender EF 1.4x III and



Extender EF 2x III, for additional reach and versatility.

### Telephoto Zoom Lenses

Canon Telephoto zoom lenses capture distant details normally missed by the unaided eye, and the unique property of these lenses to compress images can create a variety of impressive images. With lenses like Canon's new **EF 70–300mm f/4–5.6L IS USM** zoom lens, high image quality has been achieved through the use of new optics that feature two UD lens elements that effectively correct chromatic aberrations.



### Macro

The EOS lens lineup has a number of options for true close-up and macro photography. With five different macro lenses for precision, and three screw-on close-up options for convenience — in addition to Life-Size Converter EF and two Extension Tubes — Canon EF Macro lenses and close-up accessories can uncover detail that



EF 8–15mm f/4L Fisheye USM • f/4 • 1024 sec.

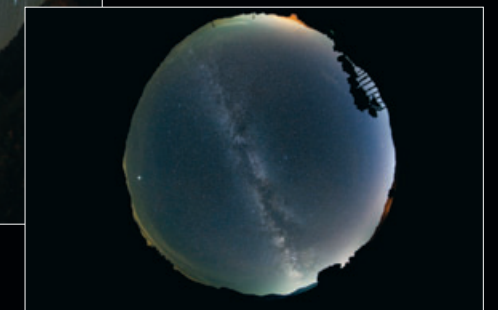

EF 8–15mm f/4L Fisheye USM • f/4 • 30 sec.

is impossible for the unaided human eye to detect.

### Fisheye Zoom

With its unique focal length range, the new Canon **EF 8–15mm f/4L Fisheye USM** is the world's widest fisheye zoom lens. It delivers 180° diagonal angle of view images for all EOS SLR cameras with imaging formats ranging from full-frame to APS-C, and provides 180° circular fisheye images for full-frame EOS models.



### TS-E

Canon's Tilt/Shift lenses bring many of the advantages of technical view cameras to the EOS System. Tilt movements alter the angle of the plane of focus between the lens and film plane, allowing precise control of depth-of-field even at large apertures. Shift movements slide the lens's optical axis along the film/sensor plane, enabling photographers to correct or alter perspective at almost any angle.



### EF-S Lenses

Designed for Canon EOS Digital cameras with APS-C sized sensors (with a 1.6x conversion factor), Canon EF-S lenses take advantage of the sensor's smaller size to deliver optimized performance in compact, lightweight designs.



### Extenders

Canon's Extender EF1.4X III and Extender 2.0X III have been completely redesigned and optimized to take advantage of the latest technologies and performance of Canon's new Super Telephoto lenses. Both have improved durability, higher image quality, and more AF precision when attached to these new lenses.



The diagram below shows the relationship between each image size and a 180° angle of view for each focal length.

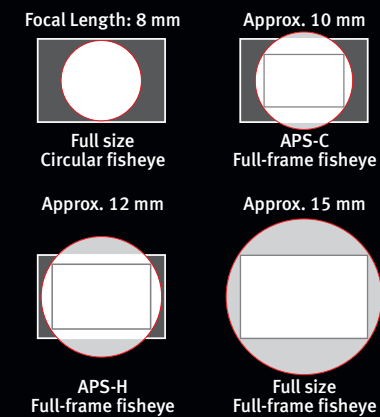

\*The red circle for each focal length is the size of a 180° angle of view on the image plane.

# Smarter Flash Photography

Integral to the EOS System, Canon Speedlites are the ideal flash light source for EOS SLR cameras. They are technologically advanced to provide perfect exposure and illumination with just about any subject. They are also highly adaptable, providing an endless variety of configurations and versatile shooting options. For professional flash photography, rely on Canon Speedlites to solve the most demanding lighting challenges.

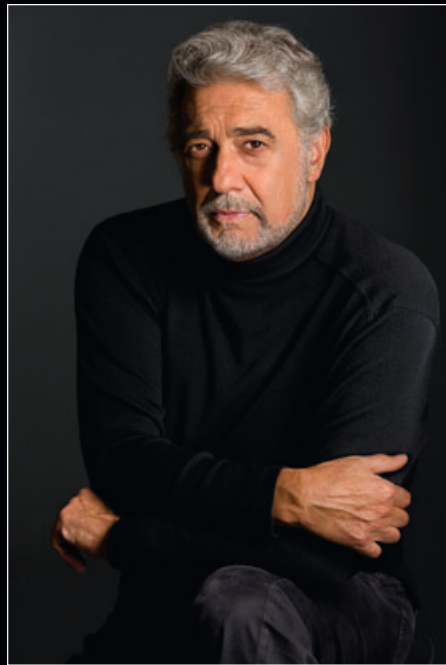

Opera singer, Plácido Domingo  
©2009 Greg Gorman. All Rights Reserved.

## E-TTL II

Canon E-TTL (Evaluative Through-The-Lens) flash exposure control uses a preflash fired after the shutter button has been fully depressed — but before the camera's reflex mirror goes up. The camera's Evaluative metering sensor — the same sensor that reads ambient light — is used to compare the ambient light values with the light reflected from the subject by the preflash. The camera then calculates and

stores the flash output required for optimum exposure of the main subject and the background.

E-TTL II additionally incorporates distance information from compatible EF lenses for the most precise flash exposure control. For example, it ignores sensor areas that report abnormally high levels, eliminating underexposure that can otherwise be caused by straight reflections. Correct flash exposure is ensured even when shooting a subject with a highly reflective object in the background, or if the subject itself is highly reflective. In addition, because distance information is used in calculating the flash output level, E-TTL II prevents over-exposure when photographers lock focus and recompose.

## Wireless Auto Flash Control

Multiple Speedlites can obtain lighting effects not possible with a single flash. While previous multiple-flash setups required cumbersome wires to connect the camera and flashes, compatible EOS Speedlites can be used as wireless Slaves. With a Speedlite 580EX II or Speedlite Transmitter ST-E2 attached to an EOS Digital SLR, an unlimited number of compatible EX-Series Speedlites can operate as dedicated Slave units. Some EOS models, like the EOS 7D and EOS 60D even incorporate an Integrated Speedlite Transmitter in their built-in flash units. With nothing more than an EOS camera and a number of Speedlite flashes, the opportunities for creative lighting are endless.

## Macro Photography and Wireless Options

The Canon Speedlite flash system family includes versatile solutions for macro photography requirements: The **Macro Ring Lite MR-14EX** features twin circular flash tubes that can be fired at equal or uneven power with a ratio that can be varied over a six-stop range. One or more compatible EX-Series Speedlites can be used as wireless slaves along with the MR-14EX. Incandescent focusing lamps and two types of modeling flash are provided to enable preview of lighting effects. The controller unit features an illuminated full-information LCD panel and accepts optional hi-capacity battery packs.

The **Macro Twin Lite MT-24EX** gives serious close-up, nature and macro enthusiasts a different, directional option in macro lighting. The two separate flash heads can be swiveled around the lens and aimed independently. They can even be removed from their holder and mounted off-camera. Flash head output can also be independently adjusted with easy ratio control over a six-stop range. Like the MR-14EX, the Macro Twin Lite MT-24EX is fully E-TTL compatible with all EOS SLR bodies. Wireless E-TTL flash control is possible with one or more 580EX II, 580EX, 550EX, 430EX II, 430EX, or 420EX Speedlites configured as slave units.

The **Speedlite Transmitter ST-E2** is a dedicated controller that can be used with an unlimited number of compatible Speedlite slave flashes. The transmitter is effective over distances up to 33 ft. outdoors and 49.5 ft. indoors.

## Speedlite 580EX II

- Durable, weather-resistant construction with extensive rubber gaskets and seals.
- Metal flash “foot” with moving rubber cover for weather-resistance.
- External flash sensor for non-TTL auto flash.
- PC socket for expanded off-camera versatility.
- Recycling is about 20% faster than the original 580EX, and quieter.
- Same powerful Guide Number (max. 190 ft.) and 24mm wide coverage (with 14mm wide panel) as the previous 580EX.
- Off-Camera Shoe Cord OC-E3 and Compact Battery Pack CP-E4 form a weather-resistant system when combined with EOS-1Ds Mark III or EOS-1D Mark IV.
- Full compatibility with all EOS SLR cameras and certain PowerShot models.



## Speedlite 430EX II

- Excellent build quality, including a metal foot for added strength.
- Approx. 20% faster recycling time, compared to the previous 430EX.
- One-touch, quick-lock mechanism for easy attaching/detaching flash from camera.
- Full flash control possible on camera menu, with compatible EOS Digital SLR cameras.
- Virtually silent flash recycle.
- Zoom flash head covers range of 24-105mm; maximum Guide Number 141 ft./43m at ISO 100.



## Speedlite Transmitter ST-E2

- Dedicated transmitter to control unlimited number of Slave flashes.
- Speedlites 580EX II, 580EX, 550EX, 430EX II, 430EX and 420EX can be controlled.
- Controls Slave units up to 33 ft. outdoors and 49.5 ft. indoors.
- Ideal compact alternative for wireless E-TTL.



## Macro Twin Lite MT-24EX

- Attaches to all Canon EF Macro lenses (EF 180mm f/3.5L requires Macro Lite Adapter 72C. EF 100mm, f/2.8L IS requires Macrolite Adapter 67).
- Ideal for close-up lighting with a directional “look.”
- Heads can be swiveled or bounced and can be removed from mounting ring for added control.
- Powerful Guide Number of 78 (feet, at ISO 100), full E-TTL control and E-TTL features including FEL, Hi-Speed Sync and Flash Exposure Bracketing.
- Incandescent focusing lamps, and two different types of 1-second modeling flash allow easy focusing and previewing of lighting effects.



## Macro Ring Lite MR-14EX

- Twin-tube ring lite designed for close-up photography with EF Macro lenses; Flash tubes can fire together or independently.
- Compatible with all EOS bodies.
- Supports E-TTL Wireless Autoflash in conjunction with one or more compatible off-camera Slave Units.
- Incandescent focusing lamps and two forms of modeling flash permit preview of lighting effects.
- Illuminated LCD panel for easy flash settings in any lighting condition.



# The Power of Wireless Connectivity

As quickly as the digital SLR has become commonplace in the hands of professional photographers and enthusiasts alike, so too has wireless communication between the SLR and external components. The EOS series has a number of dedicated Wireless File Transmitters that keep the camera connected to the wireless world, simply, with tremendous speed. Whether connected through a port on the side of the camera or incorporated into a camera-integrated design, Canon Wireless Transmitters can connect and have two-way communication with computers and handheld devices.



© 2009 Michel Tcherevkoff. All Rights Reserved.



## Canon Wireless Transmitter Technology

Canon Wireless Transmitters can, wirelessly and quickly, connect to Local Area Networks (LANs) up to 500 feet and connect and upload to FTP (File Transfer Protocol) or dedicated WFT (Wireless File Transfer) servers. In WFT Server mode, up to three separate computers, anywhere in the world, can access a camera's memory card with the WFT using a standard web browser (Microsoft Internet Explorer™, Apple Safari™, etc.). Images can be selected from the browser window and dragged onto a comput-

er's desktop or to a folder, which copies the full file to the computer. EOS Utility connectivity allows the photographer to connect a single camera to a computer for advanced two-way communication. WFT controllers can also connect through USB or Bluetooth to GPS units, and have coordinates, altitude and time code added to each image's shooting (or EXIF) data. External hard drives can be attached for direct recording or backup. Plus, select WFT models can be used as remote control receivers, allowing for wireless shooting and control, from a range of web-enabled handheld devices — even iPhones and the iPod Touch.



## Wi-Fi & WPS

Connecting the camera to a network over Wi-Fi with a Wireless Protected

Setup (WPS) couldn't be simpler. There are three ways to connect a WFT equipped EOS with a Server: With a push button configuration (PBC Method), the photographer selects WPS on the camera and pushes the wireless LAN terminal's WPS button to make the connection. With the WPS Pin Method, the photographer selects WPS (Pin Method) on the camera and an 8-digit identification number is assigned and sent to the LAN terminal. Once confirmed, the secure connection is complete. Finally, a WPS can also be set up with a connection wizard. The photographer selects the "wizard connection" on the camera's menu, selects a Wireless LAN terminal, sets an encryption key and then enters it for a wireless connection.



WFT setting display

## File Transfer & WFT Server Mode

With a WFT and an FTP server, wireless remote live view shooting is possible over the Internet, making it possible to setup, shoot and save from a remote location. Meanwhile, through an Internet browser, the camera's Live View image can be seen, settings can be confirmed and changed, shots can be taken and images can be recorded on the camera and computer simultaneously.

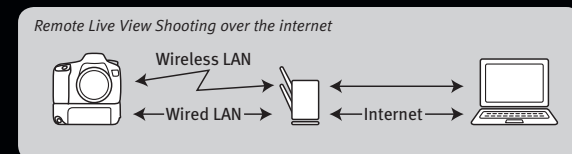

## Media Server (DLNA)

Many Canon WFT devices are compatible with DLNA (Digital Living Network Alliance) compliant devices. With a WFT attached, the Digital EOS can create a dedicated DLNA media server, allowing numerous points of access to images, instantaneously and wirelessly. This means that not only can media recorded on the EOS be uploaded wirelessly to a computer; they can also be viewed through DLNA compatible audio systems, televisions, Digital Video Players, even networked media players.

## Camera Linking

A sophisticated feature available on WFT transmitters, WFT-E2 II A, WFT-E4 II A and WFT-E5A, camera linking makes it possible for up to 10 cameras to shoot the same subject simultaneously, from different angles. Without a Wireless Access Point, up to 10 cameras can be connected and set up to take a shot the instant the shutter is released on the Master (main) camera. With an effective distance of 150 meters, this linked shooting is invaluable for the best possible capture of sports, news and wildlife and other quickly moving subjects that can be shot from a number of angles.

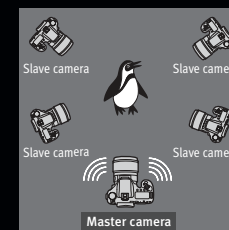

Arranging the slave cameras

## Bluetooth, USB (GPS)

Whether connected by Bluetooth or through USB, GPS devices can be connected to Canon WFT transmitters to transmit location and elevation data along with the EXIF data for each image. With Bluetooth connections, photographers can enjoy all of the benefits of GPS units without the concern of tangled wires interfering while shooting, and can connect directly to Bluetooth compatible printers. With USB, not only are GPS connections possible, it's also easy to connect an external Hard Drive for direct recording or backup.

## EOS Utility Mode

With EOS Utility (previously known as PTP), photographers can pair their camera and a computer to remotely configure camera settings, do wireless Live View com-



Remote Capture display

posing and shooting and complete image transfer with a direct wireless connection independent of a network or Internet connection. Perfect for shooting wirelessly in remote locations and for dedicated, secure connections within the studio, EOS Utility mode is a useful alternative to networked wireless shooting.

## Wireless File Transmitter WFT-E2 II A

Compatible with the EOS-1D Mark IV and the EOS-1Ds Mark III (after a Firmware upgrade), the compact WFT-E2 II A connects directly to the camera. It's IEEE 802.11 a/b/g compatible for fast communication, and works with WPS setups, the hyper-sophisticated Canon Camera Linking Function and enables WFT Server Remote Live View shooting. It can be a dedicated Media Server, plus has USB built in for connections to GPS units either directly or with an optional Bluetooth dongle. Designed to mount directly to the side of the compatible EOS camera, it maintains the integrity of all weather-resistant seals and the rugged durability of the camera while affording access to all the camera's buttons and controls.



## Wireless File Transmitter WFT-E4 II A

Built for the Canon EOS 5D Mark II, the WFT-E4 II A not only provides wireless functions, it's also a fully operational camera grip offering a full array of buttons for seamless vertical shooting. The WFT-E4 II A offers fast IEEE 802.11 a/b/g connectivity, is perfect for wireless camera linking and syncing, FTP connectivity, and operates beautifully and remotely in a professional photo studio using the EOS Utility mode. It can be a wireless media server, plus a remote Live View shooting server using the WFT Server mode.



## Wireless File Transmitter WFT-E5A

Designed not only as a fully-functioning dedicated grip with shutter release for the EOS 7D, the WFT-E5A is also an IEEE 802.11 a/b/g compatible wireless communication device offering the latest in wireless photographic shooting. It's compatible with Wireless Protected Setups (WPS), Wireless File Transfer Remote Live View and with Media Servers. It can serve as a master or as a slave unit during camera linking.

