

CANON

Manufacturer : Canon Inc.

Address : 30-2, Shimomaruko 3-Chome, Ohta-Ku, Tokyo 146, Japan

Trade Name : Canon Inc.

Model Number : H12130

Additional Model No. /Trade Names under which their device will be marketed:

Model No. N/A

Trade Names N/A

FCC ID Number: AZDH12130

Installation/Operating Instruction: See the attached.

Copyright

This manual is copyrighted by Canon U.S.A. with all rights reserved. Under the copyright laws, this manual may not be reproduced in any form, in whole or part, without prior written consent of Canon U.S.A.

© Canon U.S.A., Inc. 1997

Disclaimer

Canon U.S.A. has reviewed this guide thoroughly in order to make it an easy-to-use guide to your Canon C3500 Multifunction System. All statements, technical information, and recommendations in this guide and in any guides or related documents are believed reliable, but the accuracy and completeness thereof are not guaranteed or warranted, and they are not intended to be, nor should they be understood to be, representations or warranties concerning the products described.

Your C3500 and the software media included with your C3500 have been sold to you subject to the limited warranties set forth in the warranty and license agreement enclosed with the respective product. All software is licensed AS IS, as described in the license agreement included in the back of this guide. Further, Canon U.S.A. reserves the right to make changes in the specifications of the products described in this manual at any time without notice and without obligation to notify any person of such changes.

If you have any questions regarding your C3500 or the information in this guide, please call your local authorized Canon dealer.

Trademarks

Adobe Photoshop® and Adobe PageMaker® are registered trademarks of Adobe Corporation.

Canon® and BJ® are registered trademarks and CFX™, MultiPASS™, UHQ™, and Bubble Jet™ are trademarks of Canon Inc.

Centronics® is a registered trademark of Centronics Data Computer Corporation.

IEEE™ is a trademark of Institute of Electrical and Electronics Engineers, Inc.

Microsoft® and Windows® are registered trademarks of Microsoft Corporation.

PhotoFinish™ is a trademark of Zsoft Corporation.

WordScan™ is a trademark of Caere Corporation.

Other brand and product names may be trademarks or registered trademarks of their respective companies.



As an Energy Star Partner, Canon has determined that the C3500 meets the Energy Star guidelines for energy efficiency.

Users in the U.S.A.

PRE-INSTALLATION REQUIREMENTS FOR CANON FACSIMILE EQUIPMENT

A. Location

Supply a suitable table, cabinet, or desk. See page 2-4 and *Specifications in Appendix A*, for unit's dimensions and weight.

B. Order Information

1. Only a single line, touch tone, or rotary telephone set is to be used.
2. Order an RJ11-C modular jack (USOC code), which should be installed by the phone company. If the RJ11-C jack is not present, installation cannot occur.
3. Order a normal business line from your telephone company's business representative. The line should be a regular voice grade line or equivalent. Use one line per unit.

DDD (DIRECT DISTANCE DIAL) LINE

or

IDDD (INTERNATIONAL DIRECT DISTANCE DIAL) LINE IF YOU COMMUNICATE OVERSEAS



Canon recommends an individual line following industry standards [e.g., the 2500 (Touch tone) or 500 (Rotary/Pulse Dial) telephones]. A dedicated extension off a PBX unit without "Call Waiting" can be used with your FAX unit. Key telephone systems are not recommended because they send non-standard signals to individual telephones for ringing and special codes, which may cause a FAX error.

C. Power Requirements

This equipment should be connected to a standard 120 volt AC, three-wire grounded outlet only. Do not connect this unit to an outlet or power line shared with other appliances that cause "electrical noise." Air conditioners, electric typewriters, copiers, and machines of this sort generate noise which often interferes with communications equipment and the sending and receiving of documents.

CONNECTION OF THE EQUIPMENT

This equipment complies with Part 68 of the FCC rules. On the rear panel of this equipment is a label that contains, among other information, the FCC Registration Number and Ringer Equivalence Number (REN) for this equipment. If requested, this information must be given to the telephone company. This equipment may not be used on coin service provided by the telephone company. Connection to party lines is subject to state tariffs.

IN CASE OF EQUIPMENT MALFUNCTION

Should any malfunction occur which cannot be corrected by the procedures described in the User's Guide, disconnect the equipment from the telephone line or unplug the power cord. The telephone line should not be reconnected or the power cord plugged in until the problem is completely resolved. Users should contact their local authorized Canon dealer for servicing of equipment.

RIGHTS OF THE TELEPHONE COMPANY

Should the equipment cause harm to the telephone network, the telephone company may temporarily disconnect service. The telephone company also retains the right to make changes in facilities and services which may affect the operation of this equipment. When such changes are necessary, the telephone company is required to give adequate prior notice to the user.

WARNING

Do not make any changes or modifications to the equipment unless otherwise specified in the manual. If such changes or modifications should be made, you could be required to stop operation of the equipment.

Note: This equipment has been tested and found to comply with the limits for a Class B digital device, pursuant to Part 15 of the FCC Rules. These limits are designed to provide reasonable protection against harmful interference in a residential installation. This equipment generates, uses and can radiate radio frequency energy and, if not installed and used in accordance with the instructions, may cause harmful interference to radio communications.

However, there is no guarantee that interference will not occur in a particular installation. If this equipment does cause harmful interference to radio or television reception, which can be determined by turning the equipment off and on, the user is encouraged to try to correct the interference by one of the following measures:

- Re-orient or relocate the receiving antenna.
- Increase the separation between the equipment and receiver.
- Connect the equipment into an outlet on a circuit different from that to which the receiver is connected.
- Consult the dealer or an experienced radio/TV technician for help.

The Telephone Consumer Protection Act of 1991 makes it unlawful for any person to use a computer or other electronic device to send any message via a telephone fax machine unless such message clearly contains in a margin at the top or bottom of each transmitted page or on the first page of the transmission, the date and time it is sent and an identification of the business or other entity, or other individual sending the message and the telephone number of the sending machine or such business, other entity, or individual.

In order to program this information into your C3500, you should follow the instructions in *Entering User Information in the C3500* on page 2-50.

* Use of shielded cable is required to comply with Class B limits in Subpart B of Part 15 of FCC Rules.

Users in Canada

PRE-INSTALLATION REQUIREMENTS FOR CANON FACSIMILE EQUIPMENT

A. Location

Supply a suitable table, cabinet, or desk. See page 2-4 and *Specifications in Appendix A*, for unit's dimensions and weight.

B. Order Information

1. Provide only a single line to a touch-tone or rotary telephone set terminated with a standard 4-pin modular phone plug. (Touch-tone is recommended if available in your area.)
2. Order an RJ11-C modular jack (USOC code), which should be installed by the phone company. If the RJ11-C jack is not present, installation cannot occur.
3. Order a normal business line from your telephone company's business representative. The line should be a regular voice grade line or equivalent. Use one line per unit.

DDD (DIRECT DISTANCE DIAL) LINE

or

IDDD (INTERNATIONAL DIRECT DISTANCE DIAL) LINE IF
YOU COMMUNICATE OVERSEAS



Note

Canon recommends an individual line following industry standards [e.g., the 2500 (Touch tone) or 500 (Rotary/Pulse Dial) telephones]. A dedicated extension off a PBX unit without "Camp On" signals is also permissible with a FAX unit. Key telephone systems are not recommended because they send non-standard signals to individual telephones for ringing and special codes, which may cause a FAX error.

C. Power Requirements

The power outlet should be a three-prong grounded receptacle (Single or Duplex). It should be independent from copiers, heaters, air conditioners, or any electric equipment that is thermostatically controlled. The rated value is 120 volts and 15 amperes. The RJ11-C modular jack should be relatively close to the power outlet to facilitate installation.

NOTICE

The Industry Canada label identifies certified equipment. This certification means that the equipment meets telecommunications network protective, operational and safety requirements as prescribed in the appropriate Terminal Equipment Technical Requirements document(s). The Department does not guarantee the equipment will operate to the user's satisfaction.

Before installing this equipment, users should ensure that it is permissible to be connected to the facilities of the local telecommunications company. The equipment must also be installed using an acceptable method of connection. The customer should be aware that compliance with the above conditions may not prevent degradation of service in some situations.

Repairs to certified equipment should be coordinated by a representative designated by the supplier. Any repairs or alterations made by the user to this equipment, or equipment malfunctions, may give the telecommunications company cause to request the user to disconnect the equipment.

Users should ensure for their own protection that the electrical ground connections of the power utility, telephone lines and internal metallic water pipe system, if present, are connected together. This precaution may be particularly important in rural areas.

CAUTION

Users should not attempt to make such connections themselves, but should contact the appropriate electric inspection authority, or electrician, as appropriate."

The Ringer Equivalence Number (REN) assigned to each terminal device provides an indication of the maximum number of terminals allowed to be connected to a telephone interface. The termination on an interface may consist of any combination of devices subject only to the requirement that the sum of the Ringer Equivalence Numbers of all the devices does not exceed 5."

Contents

Chapter 1	Introducing the C3500	1-1
	Welcome	1-1
	The Main Features of the C3500	1-2
	Color Printer Features	1-2
	Plain Paper Fax Features	1-3
	Scanner Features	1-4
	Copier Features	1-5
	Telephone Features	1-5
	Using the C3500 with the MultiPASS Desktop Manager for Windows	1-6
	Supplies and Options	1-6
	BJ Print Cartridges and Ink Tanks	1-7
	Special Print Media	1-7
	Canon Photo Kit	1-7
	Safety Instructions	1-8
	Using Your Documentation	1-10
	How to Use This Guide	1-11
	Type Conventions Used in This Guide	1-11
	For Customer Support	1-12
Chapter 2	Setting Up Your C3500	2-1
	Choosing a Location for Your C3500	2-3
	Unpacking Your C3500	2-5
	Do You Have Everything?	2-5
	Removing Shipping Materials	2-8
	Getting Acquainted with Your C3500	2-11
	Front View	2-11
	Rear View	2-12
	The C3500's Controls - The Operation Panel	2-13
	Inside the Printer Cover	2-15
	Assembling the C3500	2-16
	Attaching Components	2-16
	Attaching the Sending Document Support	2-16
	Attaching the Document Support	2-17
	Attaching the Output Tray Extension	2-18
	Connecting the C3500 to Your PC	2-19
	Connecting the Telephone Line	2-20
	Connecting an Extension Phone or Answering Machine	2-20
	Powering Up	2-21

Selecting and Installing a BJ Cartridge	2-23
Guidelines for Using and Maintaining BJ Cartridges	2-23
Choosing the Best Cartridge	2-25
Installing the BJ Cartridge	2-27
Storing BJ Cartridges	2-32
Selecting and Loading the Print Media	2-33
Selecting the Print Media	2-33
Plain Media	2-33
Canon Media	2-34
The Printable Area	2-36
Plain Paper and Special Media	2-36
Envelopes	2-37
Adjusting the Paper Thickness Lever	2-38
Loading the Print Media	2-40
Loading Print Media for Automatic Feed	2-41
Loading Print Media for Manual Feed	2-45
Using Canon's Specialty Papers	2-46
Printing on High Resolution Paper HR-101	2-46
Printing on FS-101 Fabric Sheets	2-48
Using the Paper Output Guides with the BC-22 Cartridge	2-49
Entering User Information in the C3500	2-50
Guidelines for Entering Information	2-51
Entering a Name	2-51
Editing Information	2-52
Entering Your Identification Information	2-53
Editing Your Identification Information	2-54
The C3500 Menu System	2-55
Testing the C3500	2-56
Chapter 3	
Printing from Your PC	3-1
Paper Handling	3-2
Selecting Paper Types	3-2
Printing on Envelopes	3-2
Some Advice for Color Printing	3-6
Selecting Paper and Other Print Media	3-6
Understanding Your Application's Capabilities	3-6
Understanding Your Computer's Monitor and Color	3-7
Improving Print Speed	3-8
Controlling Printing Costs	3-9

Chapter 4	Scanning Documents and Making Copies	4-1
	Scanning Documents	4-2
	Types of Documents You Can Scan	4-2
	Effective Image Size	4-3
	Loading the Document	4-4
	Adding Pages to the Document in the Feeder	4-7
	Trouble With Multipage Documents	4-8
	Making Copies	4-9
Chapter 5	Sending and Receiving Faxes	5-1
	Preparing to Send a Fax	5-3
	Setting the Resolution and Contrast	5-3
	Setting the Resolution	5-3
	Sending Faxes	5-5
	Preparing to Fax a Document	5-5
	Manual Sending	5-6
	Memory Sending	5-6
	Cancelling a Transmission	5-8
	Automatic Speed Dialing	5-9
	Using One-Touch or Coded Speed Dialing	5-9
	Automatic Redialing	5-11
	Cancelling Automatic Redialing	5-12
	Redialing with Manual Sending	5-12
	Sequential Broadcasting	5-10
	Using Group Dialing	5-14
	If the Power Goes Out	5-15
	Receiving Faxes	5-16
	Setting the Receive Mode	5-17
	Receiving Faxes and Phone Calls Automatically: Fax/Tel Mode	5-18
	Receiving Faxes Manually: Manual Mode	5-19
	Receiving Faxes Automatically: Fax Only Mode	5-20
	Using an Answering Machine: Ans. Machine Mode	5-21
	Using the C3500 with an Answering Machine	5-21
	Messages Displayed When Receiving Faxes in Memory	5-22
	Printing Documents Stored in Memory	5-23
	Receiving While Registering, Copying, or Printing	5-23

Chapter 6	Troubleshooting	6-1
	If You Cannot Solve the Problem	6-3
	Problems Index	6-4
	Paper Jams	6-6
	Jams in the Automatic Document Feeder (ADF)	6-6
	Jams in the Sheet Feeder	6-8
	Printing Problems	6-9
	Print Quality Problems	6-14
	Color Printing Problems	6-16
	Problems Feeding Paper Into the C3500 Sheet Feeder	6-19
	Faxing Problems	6-22
	Sending Faxes	6-22
	Receiving Faxes	6-24
	Telephone Problems	6-27
	Copying Problems	6-28
	General Problems	6-29
	Error Codes, Messages, and Solutions	6-30
Chapter 7	Maintaining Your C3500	7-1
	Cleaning the C3500	7-2
	Cleaning the C3500's Exterior	7-2
	Cleaning the C3500's Interior	7-2
	Maintaining BJ Cartridges	7-4
	Cleaning and Testing the BJ Cartridge Print Head	7-4
	When to Replace the BJ Cartridge	7-5
	Replacing an Ink Tank in the BC-21 Color BJ Cartridge	7-7
	Replacing the BJ Cartridge	7-11
	Transporting the C3500	7-15
Appendix A	Specifications	A-1
	General	A-1
	Printer	A-2
	Printable Area: Papers	A-3
	Printable Area: Envelopes	A-4
	Scanner	A-5
	Document Sizes	A-6
	Plain Paper Fax	A-7
	Copier	A-8
	Telephone	A-9
	PC Interface	A-9
	MultiPASS Desktop Manager for Windows	A-9
	Glossary	G-1
	Index	I-1

Chapter 1

Introducing the C3500

Introducing the
C3500

Welcome

Thank you for purchasing the new Canon C3500. We are sure that your C3500 will help you work more effectively and help you easily and conveniently meet your fax and phone requirements, as well as your printing, copying, and scanning needs.

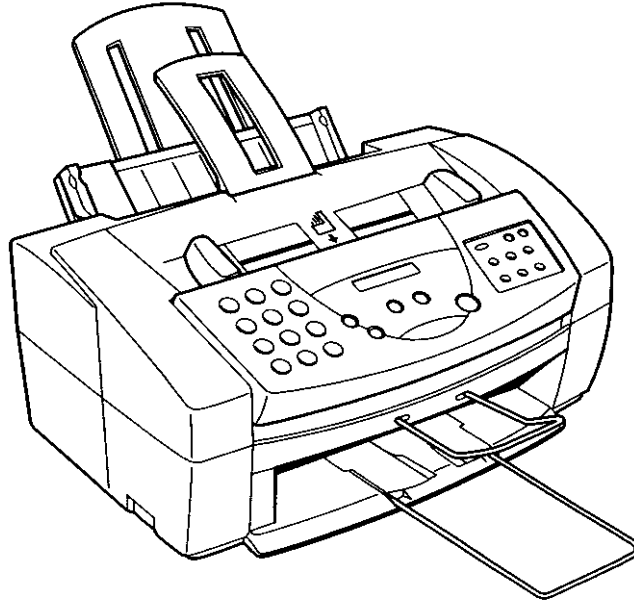

The Main Features of the C3500

The C3500 is a complete multifunction system for your home or small office. The C3500 combines the following essential office machines into a single, convenient desktop unit:

- Color printer
- Plain-paper fax machine
- Copier
- Scanner
- PC Fax
- Telephone (requires an extension telephone or answering machine)

Your C3500 also includes the MultiPASS Desktop Manager for Windows®, version 2.10. This exclusive Canon software package provides you with a “PC Fax” — you can print, fax, scan, and use the telephone from within your PC’s Windows environment.

The C3500’s multitasking ability enables you to perform a number of operations simultaneously. For example, you can print, scan a document, or make copies at the same time you are sending a fax or receiving a fax into memory.

The compact size of the C3500 (15.75 inches wide by 14.2 inches long by 7.75 inches high) makes it ideal for desktop use, and lets you use it in places where other machines might not fit.

Color Printer Features

Canon Bubble Jet (BJ) printing and ink cartridges

The C3500 uses Canon’s Bubble Jet (BJ) printing and ink cartridges to provide you with first-rate, crisp print and vibrant colors, along with convenient, easy maintenance.

Excellent print quality and speed

The C3500’s high-performance print head offers a precision of up to 720 dots per inch (dpi) horizontally by 360 vertically, providing you with high-resolution color, text, and graphics, all at exceptional speed — up to five pages per minute.

Impressive output on a variety of media

The C3500 can provide sharp black or vibrant color printing on a wide variety of media, including letter, legal, and A4 plain paper, glossy paper, envelopes, transparencies, back print film (for display on a backlight panel), and fabric sheets.

Convenient paper handling

The unit's sheet feeder holds up to 100 sheets of plain letter, legal, or A4 paper; 50 transparency sheets; or 15 envelopes.

Economy ink-saving printing

The C3500 includes an economy printing mode that uses up to 50% less ink, resulting in longer cartridge life.

Photo Quality Printing

Canon's optional Photo Kit enables the C3500 to use halftones to print photos beautifully.

Plain Paper Fax Features

UHQ™ Image Processing System

The C3500 uses Canon's Ultra-High Quality Image Processing System to provide enhanced definition in faxed photos.

Error Correction Mode (ECM)

Using the C3500's Error Correction Mode reduces transmission errors when sending faxes to or receiving faxes from other fax machines that also have ECM capability.

Automatic switching between fax and voice calls

The C3500 can automatically distinguish between fax calls and normal telephone calls, so that you can receive both through a single phone line.

Answering machine hook-up

You can connect an answering machine to the C3500 to let it receive telephone messages and faxes while you are away from your desk.

Transmission speed

The C3500 uses G3 data encoding methods that increase transmission speed to approximately 6 seconds per page.

Memory sending/receiving

The C3500 can store up to 42 fax pages (either received or to be sent) in its built-in memory, and can receive faxes while printing or even when your PC is turned off.

Reduced-size printing

The C3500 automatically scales received faxes to fit the size of the paper loaded into the sheet feeder. So if your client is sending you a fax on A4 paper and you have letter-sized paper in your sheet feeder, the fax will be scaled and printed on letter-sized paper.

Automatic dialing and broadcasting

To make faxing even easier, the C3500 provides several automatic dialing methods: coded speed dialing, one-touch speed dialing, and group dialing. The C3500 also enables you to broadcast faxes or send delayed faxes to as many as 57 locations at once.

Point-and-click dialing

The MultiPASS Desktop Manager enables you to select a fax number and dial directly from your PC's screen with a simple click of the mouse.

Scanner Features

Automatic Document Feeder

The C3500 includes an Automatic Document Feeder (ADF) that makes it easy to fax or scan up to 20 pages at a time when using Windows applications that support the TWAIN scanning standard (see below) and multi-page scans.

200-, 300-, or 400-dpi resolution

The C3500 can scan documents at 200 dpi, electro-enhanced 300 dpi, or electro-enhanced 400 dpi.

TWAIN compatible

The C3500 supports the TWAIN scanning standard, which allows you to scan images using any graphics or optical character recognition (OCR) application that also supports the TWAIN standard.

256-level grayscale

When you use the grayscale settings in the C3500 Desktop Manager, you can scan photos with 256 levels of gray, rather than just in black and white, ensuring that the photos are reproduced as clearly as possible.

Copier Features

Up to 99 copies

The C3500 can make up to 99 copies of a document at a time, at a rate of up to three copies per minute.

360-dpi resolution

The C3500 copies documents using a high resolution of 360 dpi.

Copy reduction

The C3500 can reduce copies to 70%, 80%, or 90% of their original size. This lets you copy legal-size documents onto letter-size paper, for example.

Introducing the
C-3500

Telephone Features

Automatic dialing

The C3500's three automatic dialing methods (one-touch speed dialing, coded speed dialing, and group dialing) can be used to store phone numbers, as well as fax numbers.

Connection for an answering machine and extension telephone

Connecting an extension phone to the C3500 lets you use it to make and receive normal telephone calls. In addition, connecting an answering machine allows you to receive faxes and phone messages while you are away from your desk.

Distinctive Ring Pattern Detection (DRPD)

If you subscribe to a DRP service from your telephone company, you can use the C3500's DRPD feature to automatically distinguish incoming fax calls from telephone calls, based on a distinctive ring pattern assigned to the called number.

Point-and-click dialing

The MultiPASS Desktop Manager enables you to select a phone number and dial directly from your PC's screen with a simple click of the mouse.

Using the C3500 with the MultiPASS Desktop Manager for Windows

Canon's MultiPASS Desktop Manager for Windows allows you to use the C3500's printing, faxing, scanning, and telephone functions directly from your PC:

- Use the C3500 as the default printer for Windows applications
- Send faxes from the C3500 using any Windows application that allows printing
- Scan documents into the Desktop Manager or any Windows application that supports the TWAIN scanning standard
- Store an unlimited list of fax or phone numbers in a fax/telephone address book on your PC
- View faxes on your PC's monitor, as well as save, rotate, or print them, or copy them to the PC's clipboard
- Broadcast faxes from your PC to any number of destinations
- Attach custom cover sheets to each fax you send from the PC

The Desktop Manager package also includes a utility program that helps you troubleshoot the interface between your computer and the C3500.

Supplies and Options

Your C3500 uses Canon's Bubble Jet (BJ) cartridges and ink tanks, print media, and optional equipment, all designed to work with your C3500 to help you produce the finest output possible. These supplies are available from your local authorized Canon dealer.

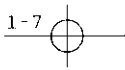

BJ Print Cartridges and Ink Tanks

The C3500 uses Canon's BJ (Bubble Jet) cartridges to provide you with first-rate, crisp print and vibrant colors.

Canon's BJ cartridges use advanced ink formulas that dry quickly, look great on plain paper, are not easily affected by light, and resist smudging extremely well. In addition, the print heads in the BJ cartridges cap themselves automatically when not in use, thus saving ink by keeping the print heads from drying out.

BJ print cartridges are also easy to maintain. If your BC-21 Color BJ Cartridge runs out of ink, just replace the empty ink tank (black or color). If the BC-20 Black Cartridge or BC-22 Photo Color Cartridge runs out of ink, just replace the entire cartridge.



Note

To avoid printing problems, use only Canon BJ print cartridges and ink tanks. Other cartridges can produce unsatisfactory results. In addition, use only BCI-21 Black and BCI-21 Color ink tanks in the BC-21 Color BJ cartridge.

Special Print Media

You can use plain paper with the C3500 for excellent black and color printing, but Canon has also developed a wide range of print media to extend your printing capabilities. See "Selecting the Print Media" on page 2-33 for detailed descriptions of these media.

If you plan to use a print medium other than those made by Canon, be sure to test it in your C3500 before ordering it in bulk. If you have any questions about whether a particular medium is suitable for your C3500, please contact your local authorized Canon dealer.

Canon Photo Kit

Canon's optional Photo Kit enables the C3500 to use halftones to print photos beautifully. The kit includes the BC-22 Photo Color BJ cartridge, the SB-21 BJ cartridge container, and 60 sheets of Canon high-resolution paper (HR-101).

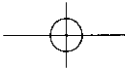

Safety Instructions

Read these safety instructions thoroughly before using your C3500, and keep them handy in case you need to refer to them later.



Except as specifically described in this manual, do not attempt to service the C3500 yourself. Never attempt to disassemble the unit: opening and removing its interior covers will expose you to dangerous voltages and other risks. For all service, contact your local authorized Canon dealer or service center.

- Always follow all warnings and instructions marked on the C3500.
- Use the C3500 only on a sturdy, stable, level surface. If the C3500 falls, it could be seriously damaged.
- Do not use the C3500 near water. If you spill liquid on or into the unit, unplug it immediately and call your local authorized Canon dealer or service center.
- The back and bottom of the C3500 include slots and openings for ventilation. To keep the C3500 from overheating (which can cause it to operate abnormally and create risk of fire), take care not to block or cover these openings. Do not operate the unit on a bed, sofa, rug, or other similar soft surface, or near a radiator or other heat source. Do not place the C3500 in a closet or cabinet or on shelves unless adequate ventilation is available. See "Choosing a Location for Your C3500" on page 2-3 for guidelines on how much space the unit needs for ventilation.
- Operate the C3500 only from the type of power source indicated on the unit's label. If you are not sure of the type of power available from your wall outlets, contact your local power company.
- The C3500 has a three-prong, grounding-type plug (the third pin is a grounding pin) that fits only into grounding-type outlets. This is a safety feature. If the outlet you intend to use is not the correct type, contact an electrician to replace it: do not use a 3-to-2 adapter, as this defeats the three-pronged plug's grounding purpose.
- Make sure the total amperage used by all devices plugged into the wall outlet does not exceed the ampere rating of the outlet's circuit breaker.

- ❑ Do not allow anything to rest on the power cord or place the C3500 where the cord will be walked on. Make sure the cord is not knotted or kinked.
- ❑ Do not insert objects of any kind into the slots or openings on the C3500's cabinet, as they could touch dangerous voltage points or short out parts, and result in fire or electric shock.
- ❑ Do not allow small objects (such as pins, paper clips, or staples) to fall into the C3500. If something does fall into it, unplug the unit immediately and call your local authorized Canon dealer or service center.
- ❑ Always unplug the C3500 before moving or cleaning it.
- ❑ Whenever you unplug the C3500, wait at least five seconds before you plug it back in.
- ❑ Keep the C3500 away from direct sunlight, as this can damage it. If you have to place it near a window, install heavy curtains or blinds.
- ❑ Do not expose the C3500 to extreme temperature fluctuations. Install the unit in a place with temperatures in the range 50°–90.5°F (10°–32.5°C)
- ❑ Always unplug the C3500 during thunderstorms.
- ❑ Before you transport the C3500, remove its BJ cartridge.
- ❑ Always lift the C3500 as shown below. Never lift it by its sheet feeder or document supports.

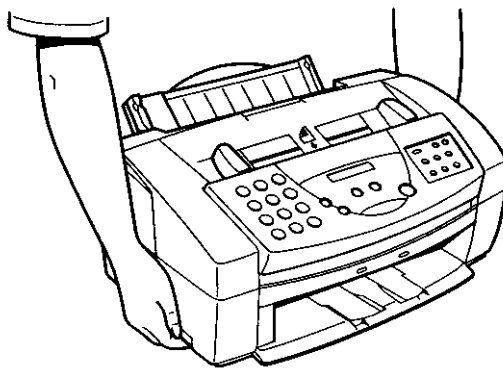

**Note**

-
- ❑ Unplug the C3500 and contact your local authorized Canon dealer or service center in any of these situations:
 - If the power cord or plug is damaged or frayed.
 - If liquid spills into the unit, or if it is otherwise exposed to rain or liquids.
 - If you notice smoke or unusual noises or odors coming from it.
 - If the C3500 does not operate normally when you follow the operating instructions. Adjust only those controls that are covered by the operating instructions in this manual, or you can damage the unit and require extensive repair work.
 - If the C3500 is dropped or its cabinet damaged.
 - If the C3500 begins performing poorly, and you cannot correct the problem by using the procedures in Chapter 6, "Troubleshooting."
 - ❑ FCC rules governing the use of fax equipment require that you register your fax number, your name or company name, and the date and time in the C3500 before using it. For instructions, see "Entering User Information in the C3500" on page 2-50.
-

Using Your Documentation

Your C3500 includes the following documentation to help you learn how to use your unit quickly and easily:

- ❑ **Quick Start Guide** — This fold-out card summarizes the steps for unpacking and setting up your C3500. If you are an advanced user familiar with computers and similar equipment, you can follow the steps on this card and begin using your C3500 in minutes.
- ❑ **User's Guide** (this guide) — This guide provides detailed information on how to set up, operate, maintain, and troubleshoot your C3500.
- ❑ **MultiPASS Desktop Manager for Windows® User's Guide** — This guide describes how to use your C3500 to print, scan, and fax from within your PC's Windows environment. Refer to this guide whenever you need information about printing, scanning, or faxing from your PC.

How to Use This Guide

To make the best use of this user's guide in learning how to set up and operate your C3500, be sure to do the following:

- ❑ Read this chapter to learn about the C3500's main features, available supplies and options, and guidelines on using the unit safely.
- ❑ Carefully follow the instructions in Chapter 2, "Setting Up Your C3500" to get your unit unpacked and assembled properly.
- ❑ Read Chapters 3 through 5 to learn how to use the C3500 to print, scan documents, make copies, and send and receive faxes.
- ❑ If your C3500 begins operating improperly, use Chapter 6, "Troubleshooting," to try to solve the problem.
- ❑ Look over Chapter 7, "Maintaining Your C3500" to become familiar with procedures for cleaning your C3500, replacing its Bubble Jet (BJ) print cartridge and ink tanks, and printing activity management reports.
- ❑ Refer to Appendix A for the C3500's technical specifications.

If you still have questions about how to use your C3500, please contact your local authorized Canon dealer or service representatives. They will be happy to answer your questions.

Type Conventions Used in This Guide

This guide uses the following conventions to emphasize certain information that will help you use your C3500 correctly and safely:



Caution

Cautions tell you how to avoid actions that could injure you or damage your C3500.



Note

Notes provide advice for using your C3500 more effectively, describe operating restrictions, and tell how to avoid minor operating difficulties.

In addition, this guide uses bold capital letters to show the names of buttons and switches on the C3500, such as **FUNCTION**, **STOP**, and **START/COPY**. Text that appears in the unit's display is shown in plain capital letters: RECEPTION OK.

For Customer Support

Your C3500 is designed with the latest technology to provide trouble-free operation. The warranty information at the back of this user's guide describes Canon's limited warranty for its products. Be sure to read this warranty information, as well as the Canon Customer Software License Agreement also included at the back of this guide.

If you have a problem with the unit's operation, try to solve it by using the information in Chapter 6, "Troubleshooting." If you cannot solve the problem or if you think your C3500 needs service, contact your local authorized Canon dealer or service center.

Chapter 2

Setting Up Your C3500

This chapter tells you how to unpack and assemble your C3500, select and install the Bubble Jet (BJ) print cartridge, load the paper, and enter your user information — everything you need to know to get your C3500 ready to use.

- ❑ Choosing a Location for Your C3500 2-3
- ❑ Unpacking Your C3500 2-5
 - Do You Have Everything? 2-5
 - Removing Shipping Materials 2-8
- ❑ Getting Acquainted with Your C3500 2-11
 - Front View 2-11
 - Rear View 2-12
 - The C3500's Controls - The Operation Panel 2-13
 - Inside the Printer Cover 2-15
- ❑ Assembling the C3500 2-16
 - Attaching Components 2-16
 - Attaching the Sending Document Support 2-16
 - Attaching the Document Support 2-17
 - Attaching the Output Tray Extension 2-18
 - Connecting the C3500 to Your PC 2-19
 - Connecting the Telephone Line 2-20
 - Connecting an Extension Phone or Answering Machine .. 2-20
- ❑ Powering Up 2-21
- ❑ Selecting and Installing a BJ Cartridge 2-23
 - Guidelines for Using and Maintaining BJ Cartridges 2-23
 - Choosing the Best Cartridge 2-25
 - Installing the BJ Cartridge 2-27
 - Storing BJ Cartridges 2-32

Setting Up Your
C3500

- ❑ Selecting and Loading the Print Media 2-33
 - Selecting the Print Media 2-33
 - Plain Media 2-33
 - Canon Media 2-34
 - The Printable Area 2-36
 - Plain Paper and Special Media 2-36
 - Envelopes 2-37
 - Adjusting the Paper Thickness Lever 2-38
 - Loading the Print Media 2-40
 - Loading Print Media for Automatic Feed 2-41
 - Loading Print Media for Manual Feed 2-45
 - Using Canon's Specialty Papers 2-46
 - Printing on High Resolution Paper HR-101 2-46
 - Printing on FS-101 Fabric Sheets 2-48
 - Using the Paper Output Guides with the BC-22 Cartridge .. 2-49
- ❑ Entering User Information in the C3500 2-50
 - Guidelines for Entering Information 2-51
 - Entering a Name 2-51
 - Editing Information 2-52
 - Entering Your Identification Information 2-53
 - Editing Your Identification Information 2-54
- ❑ The C3500 Menu System 2-55
- ❑ Testing the C3500 2-56

Choosing a Location for Your C3500

Before unpacking your C3500, follow these guidelines to choose the best location for it.



Please review the information provided in "Safety Instructions" on page 1-8, to make sure you are installing your C3500 for safe use.

- Put the C3500 in a cool, dry, clean, well ventilated place:
 - Make sure the area is free from dust.
 - Make sure the location is not affected by extreme temperature changes, and always stays between 50° and 90.5°F (10° and 32.5°C).
 - Make sure the area's relative humidity is always between 10% and 90%.
- Keep the C3500 away from direct sunlight.
- If possible, put the C3500 near an existing telephone outlet, to avoid the expense of installing a new one.
- Place the C3500 near an electrical wall outlet that accepts a three-prong, grounded plug, and that provides 120-volt AC (60 Hz) power. (This is standard for U.S. outlets; if you have any doubts, contact an electrician to check the power for you.)
- Place the C3500 near the PC you will be connecting it to. Make sure you can reach it easily, as you will be using it as a printer, fax machine, copier, scanner, and telephone.
- Do not plug the C3500 into the same circuit as an appliance such as an air conditioner, electric typewriter, television, or copier. Such devices generate electrical noise that can interfere with your C3500's ability to send or receive faxes.
- Set the C3500 on a flat, stable, vibration-free surface that is strong enough to carry its weight (about 13 lbs/6.0 kg).
- Make sure the location you choose provides enough space around the C3500 for adequate ventilation, and to allow paper to flow freely into and out of the unit. The figure below shows the minimum space required for the unit.

Setting Up Your
C3500

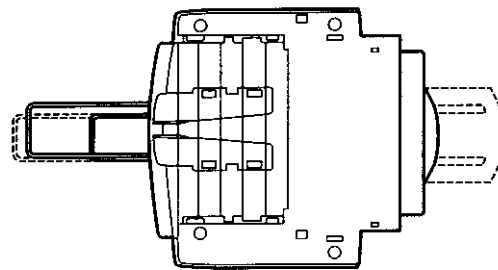
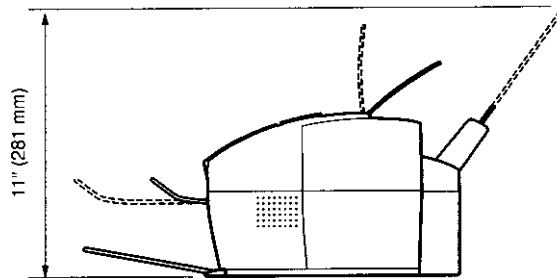
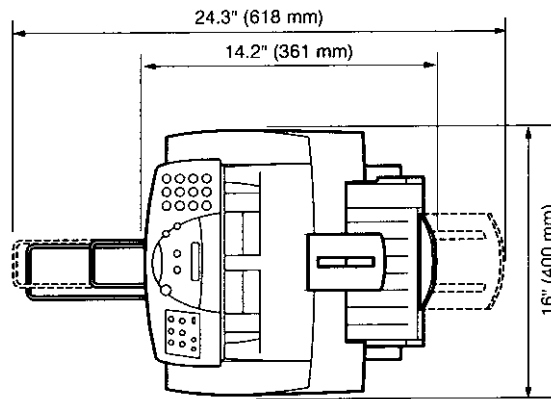

Note

If you need help installing your C3500 or have any questions about it, please contact your local authorized Canon dealer or service center.

Unpacking Your C3500

Follow the directions below to unpack your C3500 properly, and to make sure you have all of its components and documentation.

Do You Have Everything?

As you unpack the C3500, save the carton and packing material in case you want to move or ship the unit in the future.

1. Carefully remove all items from the box. You should have someone help by holding the box while you lift the C3500 and its protective packaging out of the carton.

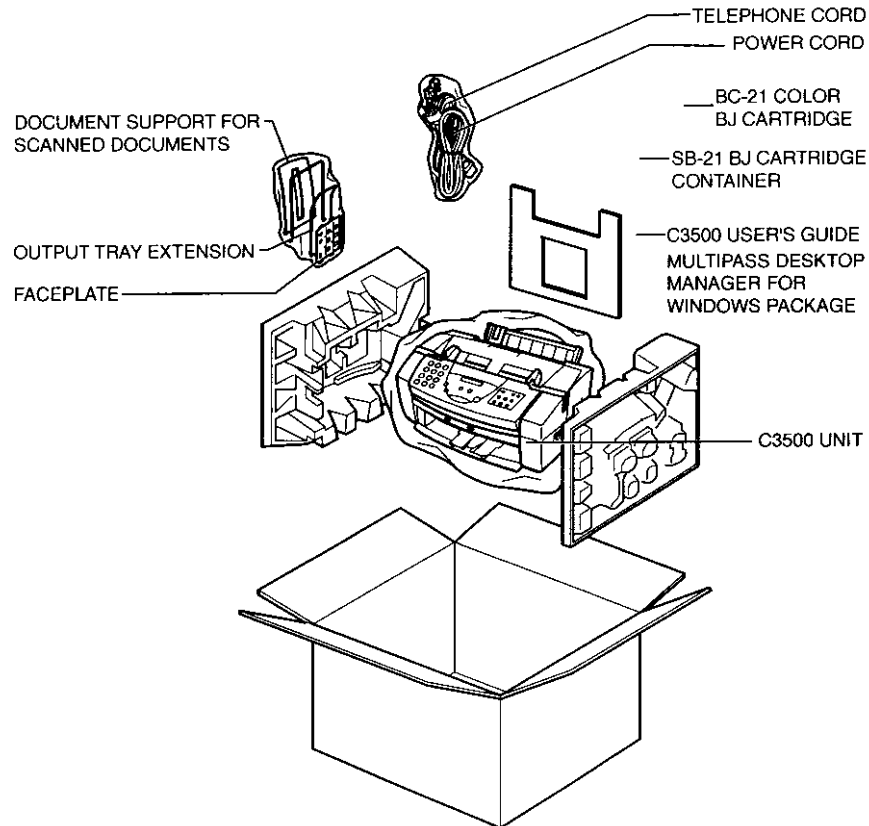

Setting Up Your
C3500

2. Make sure you have the following items:

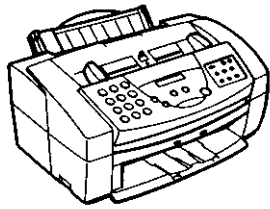

C3500 UNIT

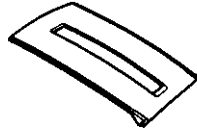

SENDING DOCUMENT SUPPORT

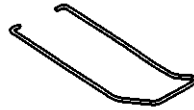

DOCUMENT SUPPORT FOR SCANNED DOCUMENTS

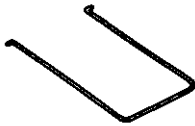

OUTPUT TRAY EXTENSION

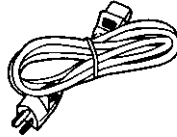

POWER CORD

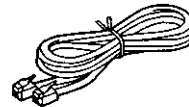

TELEPHONE CORD



SB-21 BJ CARTRIDGE CONTAINER

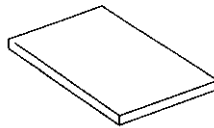

C3500 USER'S GUIDE
(This book)

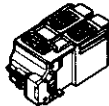

BC-21 COLOR BJ CARTRIDGE

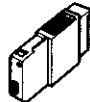

BCI-21 BLACK INK TANK



Note

The BCI-21 Black ink tank is a replacement for the black ink tank in the BC-21 Color BJ Cartridge. It should therefore not be opened until needed.

3. Also, make sure you have the following documentation and software:
 - C3500 User's Guide (this guide)
 - MultiPASS Desktop Manager for Windows package (manual and floppy disks)
 - Quick Start Guide
 - Registration Card
 - Installation Completion Report



If any of the above items are damaged or missing, notify your Canon dealer immediately.

4. In addition to the items shipped with your C3500, you will need a Centronics®-compatible parallel interface cable, which you can purchase from your Canon dealer. (Canon recommends a cable that complies with IEEE 1284.) For best results, use a cable that is no more than 6 feet (2 meters) long.
5. Fill out your registration card and send it to Canon U.S.A. Also, save your receipt for proof of purchase.

Removing Shipping Materials

When unpacking your C3500, remove the tape and cardboard that is inserted into the unit to protect it during shipping. Do this as follows:

1. Remove all pieces of shipping tape from the outside of the C3500.

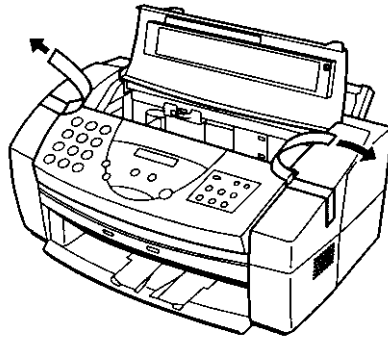

2. Remove the shipping tape and protective cardboard from the sheet feeder.

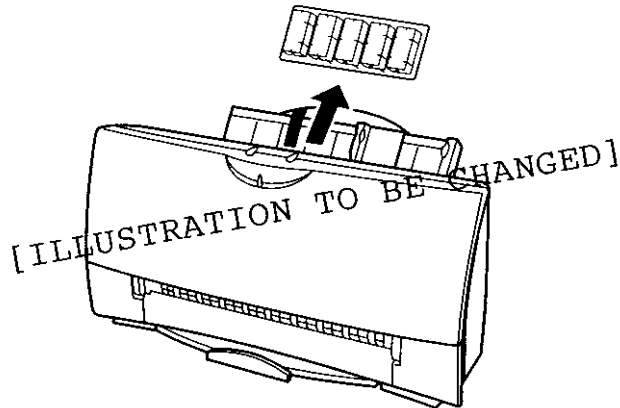

3. Open the operation panel by grasping it with both hands and gently pulling it toward you.

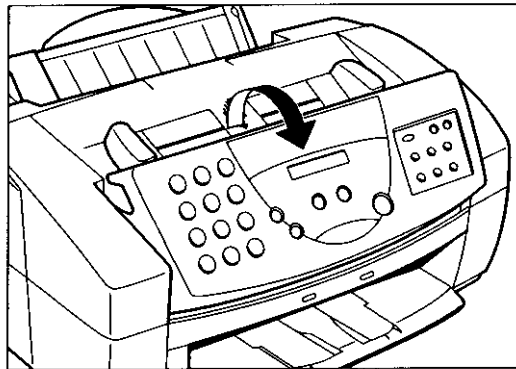

Setting Up Your
C3500

4. Remove the soft styrofoam sheet from the unit's Automatic Document Feeder (ADF), then gently push the operation panel shut until it clicks.

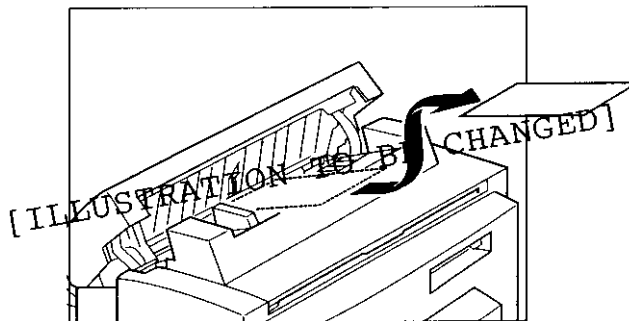

5. Peel the clear protective sheet off of the LCD display.

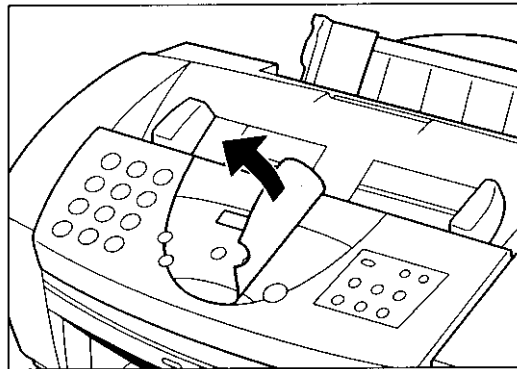

Getting Acquainted with Your C3500

Before using your C3500, look over the diagrams on these pages to become familiar with the unit's components and their functions.

Front View

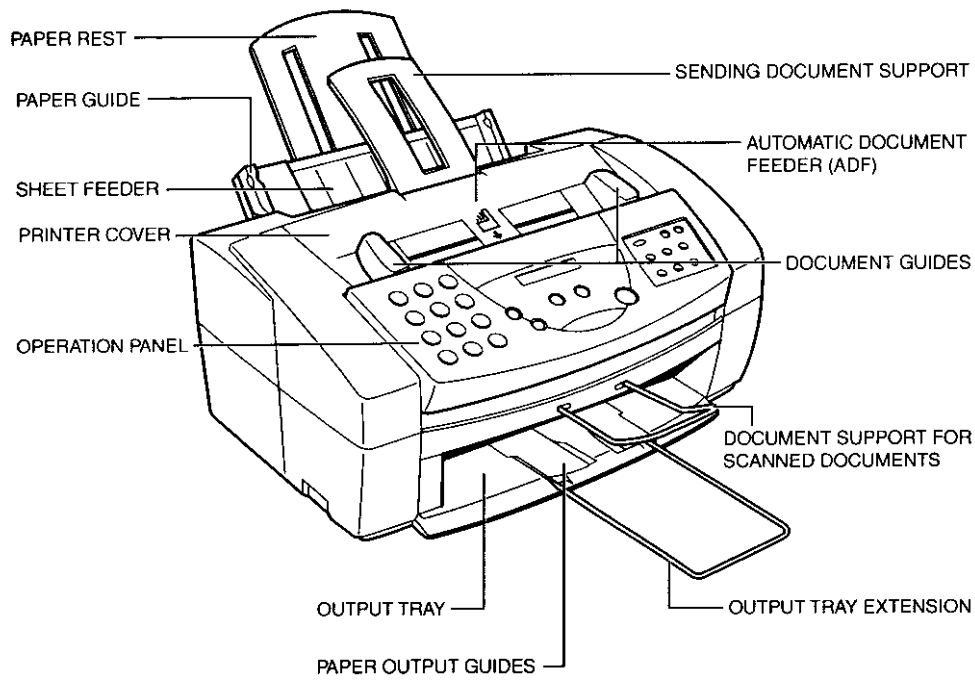

Setting Up Your
C3500

Rear View

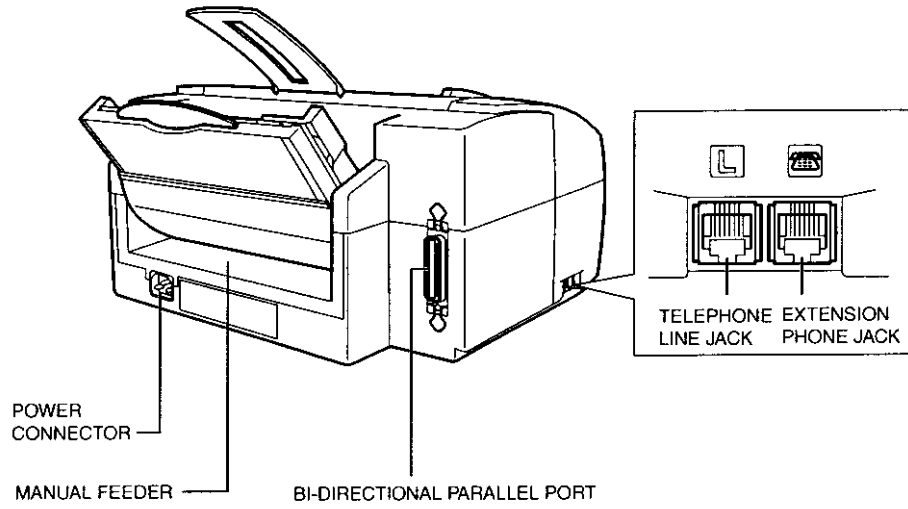

The C350's Controls — The Operation Panel

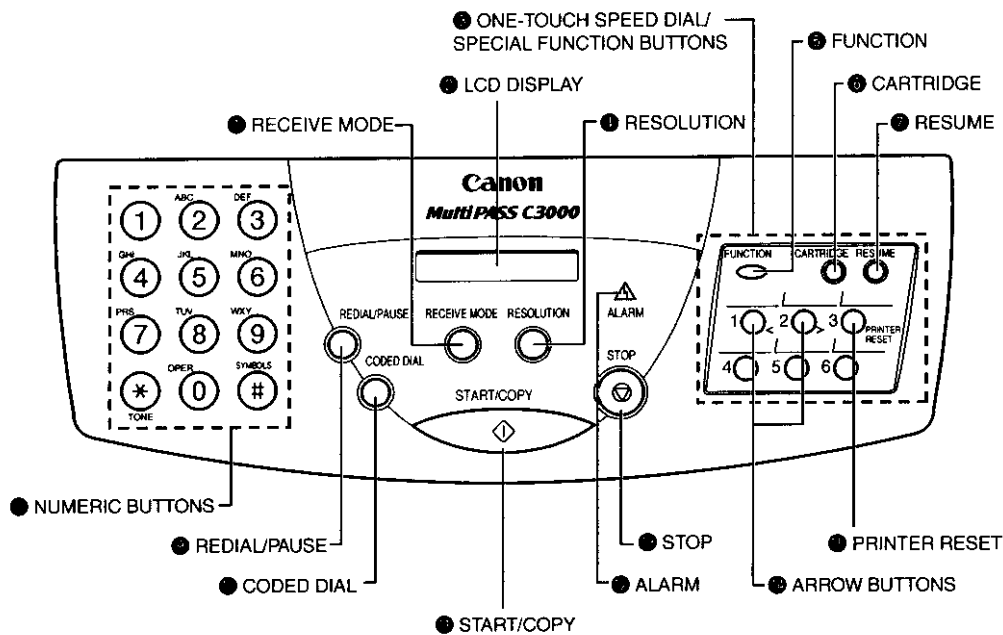

Setting Up Your
C3500

1 RECEIVE MODE button

Use this button to select whether the C3500 is set to receive faxes manually ("Manual Mode"), to treat all calls as faxes ("Fax Only Mode"), to use an answering machine to receive all calls ("Ans.Machine Mode"), or to automatically switch between telephone and fax receiving, depending on the type of call ("Fax/Tel Mode").

2 LCD display

This displays messages and prompts during operation, and displays selections, text, numbers, and names when registering information.

3 One-Touch Speed Dial/Special Function buttons

Use these for one-touch speed dialing, entering user information, printing documents stored in memory, and cleaning the print head.

4 RESOLUTION button

Press this to select the resolution the C3500 will use for the document you want to fax or scan.

- 5 FUNCTION button**
Use this to enter user information, to run the C3500's self-cleaning process, check the nozzles, or to print faxes stored in the C3500's memory.
- 6 CARTRIDGE button**
Press this to release the C3500's BJ cartridge holder to its center position for installing or replacing the cartridge. (Press again after installing the cartridge to return the cartridge holder back to its home position.)
- 7 RESUME button**
Press this when you want to form-feed paper when printing.
- 8 Numeric buttons**
Use these buttons to type numbers and names when entering information, and to dial fax/telephone numbers that are not registered for automatic dialing.
- 9 REDIAL/PAUSE button**
Press this to redial the last number that was dialed using the number buttons, or to enter pauses between digits when dialing fax numbers.
- 10 CODED DIAL button**
Press this button (followed by entering a two-digit code with the number buttons) to dial a fax number that you have registered for coded speed dialing.
- 11 START/COPY button**
Press this to begin sending, receiving, scanning, or other operations, or to select functions when registering information.
- 12 ALARM lamp**
This flashes when an error occurs, when the C3500 is out of paper or ink, or when received faxes are stored in memory.
- 13 STOP button**
Press this to cancel sending, receiving, or any other operation.
- 14 Arrow buttons (< >)**
Use these to scroll through menu selections or to move the cursor when registering data.
- 15 PRINTER RESET button**
Press this to reset the C3500 if your PC crashes. This will maintain all the faxes currently in memory. Do not unplug the C3500 to reset the unit or the faxes in memory will be lost.

Inside the Printer Cover

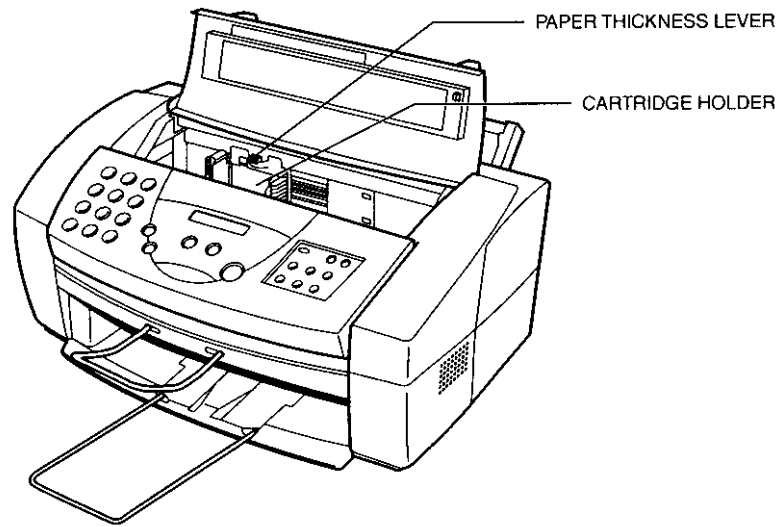

Setting Up Your
C3500

Assembling the C3500

Use the following instructions to assemble your C3500 main unit and components. To see how the C3500 will look fully assembled, see "Getting Acquainted with Your C3500" on page 2-11.

Attaching Components

Attaching the Sending Document Support

The sending document support holds documents as they feed into the Automatic Document Feeder (ADF).

To install this support, insert one of its tabs into the corresponding slot above the C3500's Automatic Document Feeder (ADF), then — firmly but gently — insert the other.



Attaching the Document Support

The document support catches documents as they come out of the C3500 after being faxed or scanned. You can operate the C3500 with or without this support.

The ends of the metal support fit into the slots on the front of the C3500, as shown below. To install it, slightly squeeze the ends of the support toward each other, insert them in the slots, and gently release them. Then slide the support into the unit until it clicks in position.

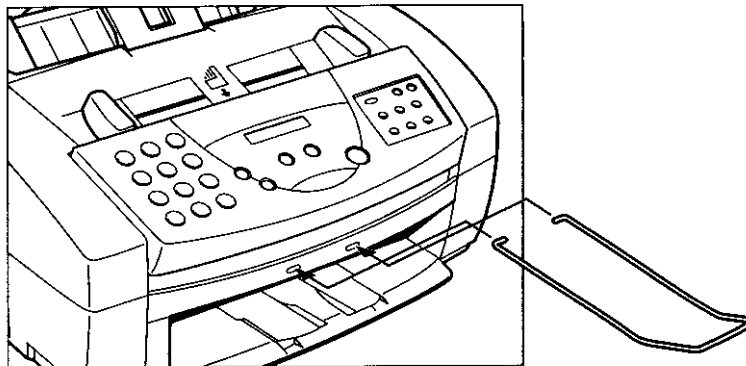

When the support is installed, you can pull it out or push it in to suit the size of the document.

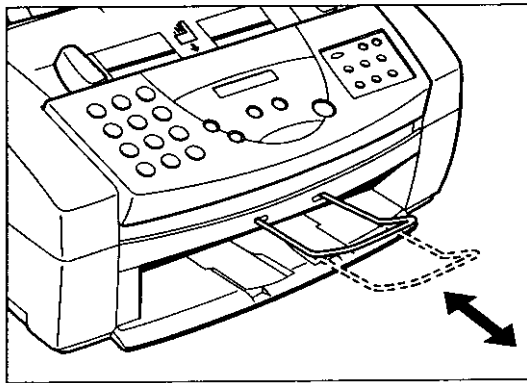

Note

- When inserting the document support, make sure that it curves upwards, as shown in the figures above.
- If you do not wish to use the support, you can remove it completely.

Attaching the Output Tray Extension

The output tray extension catches printed pages as they come out of the C3500's output tray.

The ends of the metal support fit into the slots on the output tray, as shown below. To install it, squeeze the ends of the support toward each other, insert them into the slots, and gently release them.

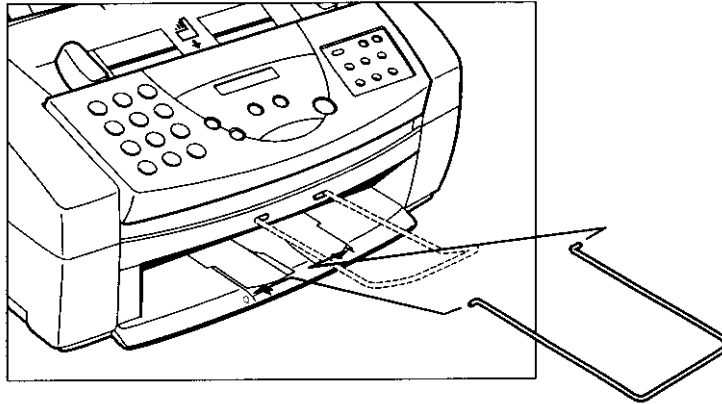

Connecting the C3500 to Your PC

Your C3500 has an 8-bit, bi-directional parallel interface port that allows you to connect to your PC. To do this, you need to purchase a Centronics-compatible parallel interface cable from your dealer.



Note

For best results, use a cable that is no more than 6 feet long. Canon recommends that you use a cable that complies with IEEE 1284. Contact your local authorized Canon dealer if you need help in selecting a cable.

Connect the C3500 to your computer as follows:

1. Make sure the computer is turned off and the C3500 is unplugged.
2. Connect the parallel cable to your C3500:
 - a. Align the cable connector with the interface port so their shapes match.
 - b. Gently press the cable connector into the port.
 - c. Secure the cable connector by snapping both wire clips (on the sides of the port) into the cable connector, as shown below.

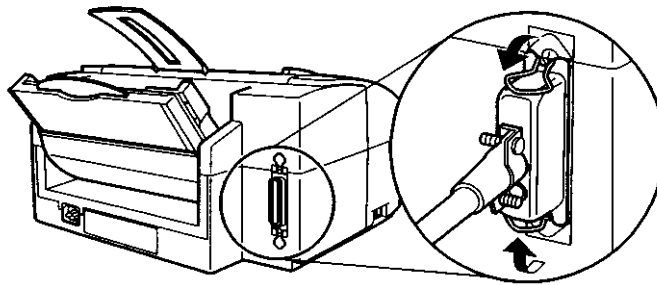

3. Similarly, connect the other end of the cable to the parallel interface port on your computer.

Connecting the Telephone Line

You need an RJ11-C type (modular) wall jack to connect the C3500 to your telephone system. Contact your local telephone company to install this type of jack if you don't have one.

Connect the C3500 to a telephone line as follows:

1. Connect one end of the supplied telephone line to the jack marked  on the side of the C3500.

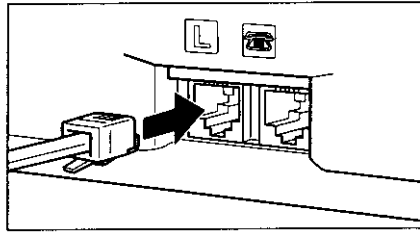

2. Connect the other end of the line to your wall telephone jack.

Connecting an Extension Phone or Answering Machine

To use your C3500 to make or receive normal telephone calls, you must connect an extension telephone. You can also attach an answering machine (with or without an extension telephone).

Do this by connecting the line from the extension phone or answering machine into the jack marked  on the side of the C3500.

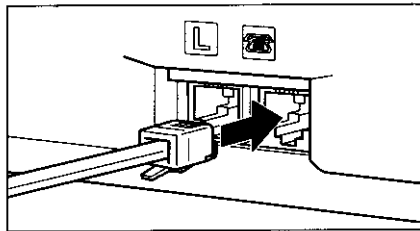

Note

If you connect an answering machine to the C3500, be sure to read "Using an Answering Machine: Ans. Machine Mode" on page 5-21.

Powering Up



Caution

Follow these guidelines when connecting your C3500 to a power source:

- ❑ The C3500 is intended for use in the U.S. and Canada only and requires 120 VAC. Do not use it outside the U.S. or Canada.
- ❑ Plug the C3500 only into a 120-volt AC, 60-Hz, three-prong grounded outlet.
- ❑ Use only the power cord that came with the unit. Using a longer cord or extension cord can cause the C3500 to malfunction.
- ❑ Unplug the unit only by pulling on the plug itself. Never pull on the cord.
- ❑ Do not plug the C3500 into an outlet shared with an appliance such as an air conditioner, computer, electric typewriter, or copier. These devices generate electrical noise, which can interfere with the C3500's operation.
- ❑ Make sure nothing is laying on the power cord, and that the cord cannot be walked on or tripped over.
- ❑ Do not overload the electrical outlet. Make sure the total amperage used by all the machines plugged into the outlet does not exceed the ampere rating of the outlet's circuit breaker.

Setting Up Your
C3500

Connect the power cord as follows:

1. Plug the supplied power cord into the power receptacle on the C3500.

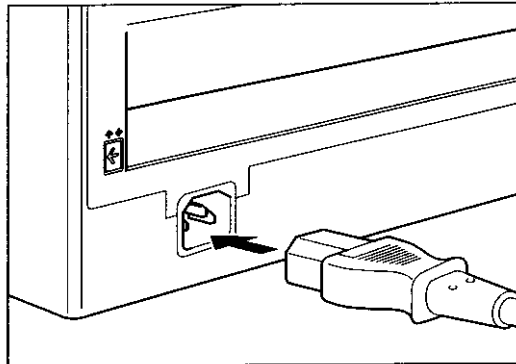

2. Plug the other end of the power cord into the outlet.



The C3500 has no power switch, so its power is on as long as it is plugged in. Once powered up, though, the unit still needs to warm up before you can use it. Depending on the number of pages accumulated in its memory, the C3500 can take up to four minutes to warm up.

3. While the C3500 is warming up, the message PLEASE WAIT appears in the LCD display:

PLEASE WAIT

4. When the date appears, the C3500 is in Standby mode and ready for use:

12/11/97 FaxTel



If the BJ cartridge has not been installed yet, the message PUT IN CARTRIDGE alternates with the Standby mode display:

PUT IN CARTRIDGE

12/11/97 FaxTel

Selecting and Installing a BJ Cartridge

Canon offers a number of Bubble Jet (BJ) cartridges to meet a wide range of printing requirements. (The C3500 comes with one BC-21 Color BJ cartridge.) This section describes how to select the best BJ cartridge for your needs, as well as how to install and maintain the cartridge.

Guidelines for Using and Maintaining BJ Cartridges

The most important thing you can do to ensure the best possible print quality, as well as extend the life of your C3500, is to take care of the C3500's BJ cartridges following these guidelines:

- Store cartridges at room temperature.
- Keep cartridges in their sealed containers until you are ready to use them.
- Install the cartridge immediately after removing its print head cap and protective tape.
- Always use the cartridge within one year of unpacking it.
- When changing cartridges, always store the unused cartridge in the SB-21 BJ cartridge container that comes with the C3500.
- Do not remove the cartridge from the C3500 unless necessary.



Note

The ink in the BJ cartridges is difficult to clean up if spilled. To avoid spilling ink, always be sure to follow these precautions when handling the cartridges:

- Do not attempt to disassemble or refill the cartridge.
- Do not shake or drop the cartridge, or tip the print head downward.
- Keep BJ cartridges out of children's reach.

**Caution**

Hold the BJ cartridge by its sides only. Do not touch the print head, the sharp edges around the print head, the silver plate on the bottom of the cartridge, or the silver metal or circuit area on its side.

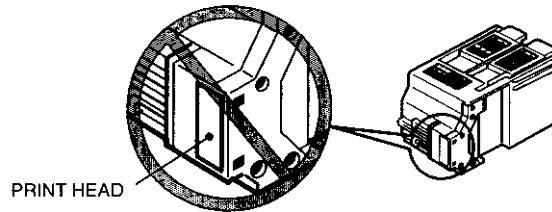

- Make sure the BJ cartridge holder is in its home position (at the right side of the unit) when you are not using the C3500. If it is not in its home position, press the **CARTRIDGE** button. Leaving it out of its home position will dry out the print head on the cartridge.
- Clean the print head when print quality is no longer satisfactory. See "Cleaning and Testing the BJ Cartridge Print Head" on page 7-4 for instructions. If the print quality does not improve after five consecutive cleanings, replace the ink tank or BJ cartridge.
- Do not use a BC-21 Color BJ cartridge with either of its ink tanks missing. Doing so can cause it to clog.
- Do not remove the ink tanks from the BC-21 Color BJ cartridge unnecessarily, or the ink in them may clog.
- Never attempt to refill an empty cartridge.

Choosing the Best Cartridge

Canon offers several BJ print cartridges and ink tanks for use in the C3500. (BJ print cartridges contain the BJ print head and ink, while BJ ink tanks contain only ink.) Use the following descriptions to decide which type of cartridge best suits your particular needs.



Note

To avoid printing problems, use only the BC-21 BJ cartridge for normal printing (or the separately sold BC-20 Black BJ cartridge, if you rarely print color). The BC-22 Photo Color BJ Cartridge (sold separately) is for printing photo-realistic color images. Other cartridges can produce unsatisfactory results. In addition, use only BCI-21 Black and BCI-21 Color ink tanks in the BC-21 Color BJ cartridge.

Setting Up Your
C-3500

BC-21 Color BJ Cartridge

The BC-21 incorporates a BJ print head and two replaceable ink tanks (a BCI-21 Black and a BCI-21 Color). Use this cartridge for normal printing.

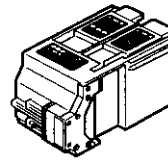

BCI-21 Black ink tank

Purchase this ink tank from your local Canon dealer as the black ink runs out of the BC-21 Color BJ cartridge.

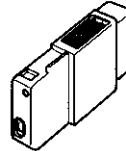

BCI-21 Color ink tank

Purchase this ink tank from your local Canon dealer as the color ink runs out of the BC-21 Color BJ cartridge.

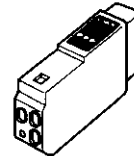

BC-20 Black BJ Cartridge

This cartridge incorporates a BJ print head and black ink in a single unit. The BC-20 can be used if most of your printing is black, e.g. for receiving faxes, making copies, and monochrome printing. It can print twice as fast as a color cartridge, and at higher resolution.

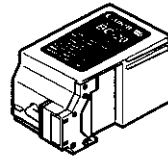

BC-22 Photo Color BJ Cartridge

Includes the print head and color ink in a single unit. Use this cartridge for printing photo-realistic color images.

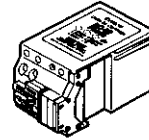
**Note**

The C3500 cannot print incoming faxes or make copies while the BC-22 cartridge is installed. This is an ink-saving feature: because the BC-22 is a single unit (and does not have ink tanks that can be replaced separately), using it to print faxes will use the black ink faster, using up the cartridge while it still has a considerable amount of color ink remaining.

SB-21 BJ Cartridge Container

Use the SB-21 to store an extra BJ cartridge in a convenient location, while keeping it from drying out.

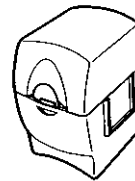
**Note**

Your C3500 unit comes with a BC-21 Color BJ Cartridge (which incorporates the BCI-21 Black and BCI-21 Color ink tanks) and an additional BCI-21 Black ink tank. When you run out of ink, or if you wish to use any other Canon BJ cartridges mentioned above, you can purchase them from a Canon Official Dealer.

Installing the BJ Cartridge

To install your BJ cartridge, follow these steps:

CARTRIDGE



1. Make sure the C3500 is plugged in.
2. Press **CARTRIDGE**.
 - The unit beeps, and the cartridge holder moves toward the center of the unit.
3. Open the printer cover by grasping the document guides and lifting.

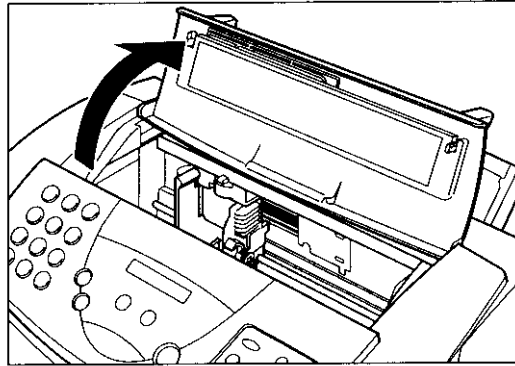

Caution

- Do not try to manually move or stop the cartridge holder, or you may damage the C3500.
- Do not touch the ribbon cable, the small circuit board, the guide rail or the round shaft.

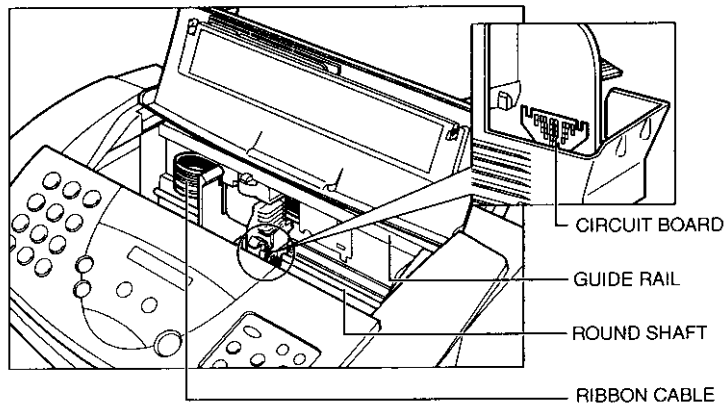

Setting Up Your
C-3500

- ❑ Hold the BJ cartridge by its sides only. Do not touch the print head, the sharp edges around the print head, the silver plate on the bottom of the cartridge, or the silver metal or circuit area on its side.

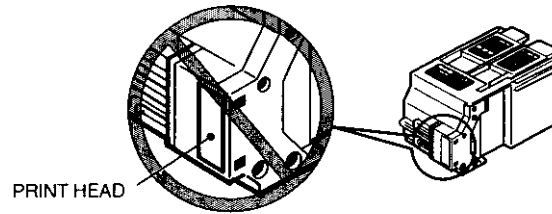

4. Raise the green cartridge lock lever (on the cartridge holder) by gently pulling up on it.

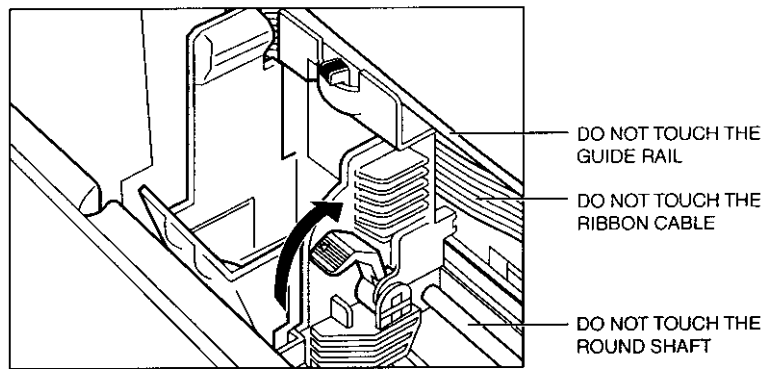

5. Peel the protective foil off the new BJ cartridge's protective packaging, and remove the cartridge.

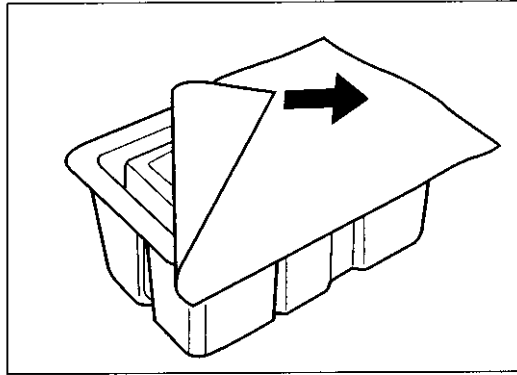

Setting Up Your
C3500

6. Lift the orange cap off the cartridge's print head, then remove the orange tape.

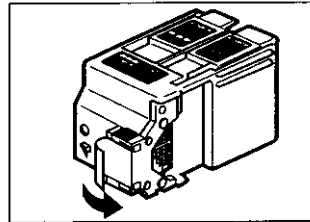
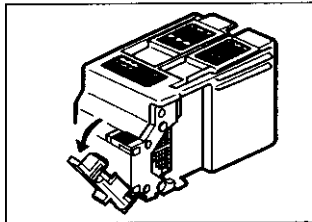



Note

Discard the cap and tape immediately. Never attempt to re-attach the cap or tape to the print head, or you can adversely affect the ink flow or quality of the ink color.

7. Hold the cartridge so the label faces outward, tilt it slightly forward and to the right, then slide it into the cartridge holder.

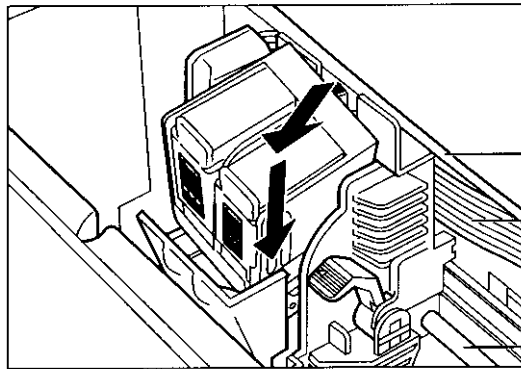

DO NOT TOUCH THE
GUIDE RAIL
DO NOT TOUCH THE
RIBBON CABLE
DO NOT TOUCH THE
ROUND SHAFT

8. Lower the green lock lever completely. The BJ cartridge is now locked into position.

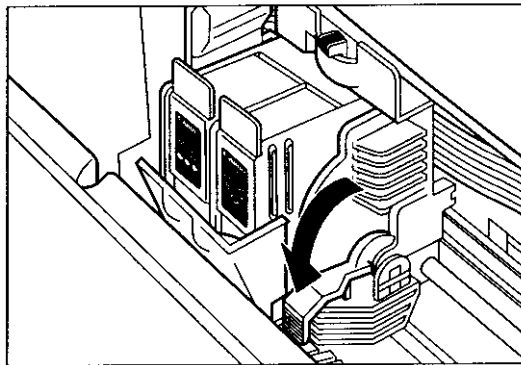

Caution

Do not try to manually move or stop the cartridge holder, or you may damage the C3500.

9. Set the paper thickness lever. For printing on plain paper:

<u>Cartridge</u>	<u>Thickness Lever Position</u>
BC-21 Color BJ Cartridge (black)	left
BC-21 Color BJ Cartridge (color)	center
BC-20 Black BJ Cartridge	left
BC-22 Photo Color BJ Cartridge	center

See page 2-38 for more information on paper thickness settings.

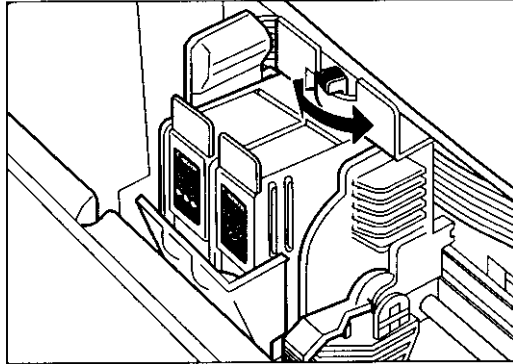

10. Close the printer cover.

CARTRIDGE



11. Press **CARTRIDGE**.

- The C3500 beeps twice, and the cartridge holder moves to its home position on the right side of the unit.
- Once the cartridge holder is in its home position, the unit automatically cleans the print head.



Note

Unplug the C3500 only when it is in Standby mode (date and receiving mode show in the LCD display). Do not unplug the C3500 when the cartridge holder is not in its home position on the right. If you unplug the unit while it is printing, or move the cartridge holder from its home position, the cartridge will not be capped and can dry out.

Setting Up Your
C3500

Storing BJ Cartridges

Once a BJ cartridge is unwrapped, its print head must be kept from drying out, or it can clog and fail to work properly. A cartridge installed in the C3500 is protected from drying out by automatically moving to the home position at the right side of the unit and capping itself.

If you remove a partially used BJ cartridge from the C3500, store it in the SB-21 BJ cartridge container that came with your unit.

1. Insert the cartridge in the container with the cartridge's label facing forward, and the print head down.

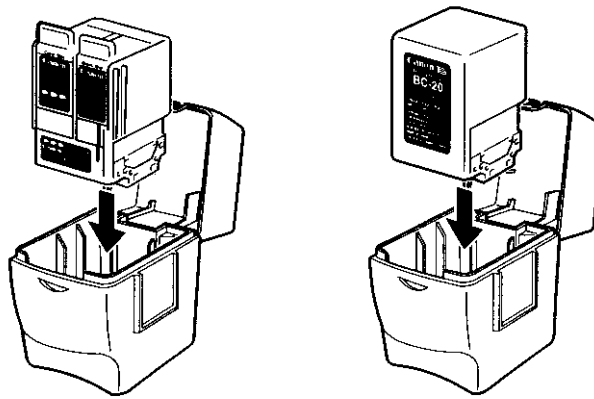

2. Close the container lid, and snap it shut.

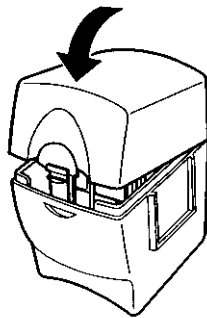

Selecting and Loading the Print Media

The C3500 can provide sharp black or vibrant color printing on a wide variety of media, including letter, legal, and A4 plain paper, glossy paper, envelopes, transparencies, back print film (for display on a backlight panel), and fabric sheets.



Note

Whenever you change the size of the paper in the C3500, you must also use the MultiPASS Desktop Manager to set the C3500 to use the new size. For instructions, see the *MultiPASS Desktop Manager for Windows® User's Guide*.

Setting Up Your
C3500

Selecting the Print Media

The following describes a variety of media you can use with your C3500. Be sure to test the medium you intend to use before ordering it in bulk. If you have any questions about whether a particular medium is suitable for your C3500, please contact your local authorized Canon dealer. For complete paper specifications, see "Printer" on page A-2.

Plain Media

Plain paper

The C3500 produces letter-quality print on most plain bond paper, including cotton bond and photocopy paper. It can use A4, letter, or legal sizes. The paper must be less than 0.008 inch (0.2 mm) thick, and have a weight of 17–24 lbs (64–90 g/m²).



Note

You can also use paper weighing 24–28 lbs (90–105 g/m²) by manually feeding sheets, one at a time.

Envelopes

The C3500 can print on U.S. Commercial No. 10 (9.5 x 4.1 inches) and European DL (220 x 110 mm) envelopes.

Canon Media

Canon provides the following media, all specifically developed to extend the printing capability of your C3500. For details or purchase, contact your local authorized Canon dealer.

Canon Bubble Jet Paper LC-301 (water resistant)

This is a water-resistant, letter-size paper specially developed for color printing with Canon Color BJ printers such as the C3500. Images printed on LC-301 paper are bright and vivid, and will not run if liquid is spilled on them. Images printed on this paper stand up to normal office highlighters, unlike images printed on other papers.

Canon High-Resolution Paper HR-101

This paper is designed to produce near-photographic quality print output, with sharp, vivid graphics and photographs. You must use this paper when printing with the BC-22 Photo Color BJ Cartridge. When using HR-101 paper, be sure to print on the whiter side of the sheets, and after printing a pack of this paper, use the cleaning sheet provided with it to clean the printer roller.

Canon Transparencies CF-102

These letter-size overhead transparencies are specially designed for Canon BJ color printers. Use these clear transparencies to produce crisp and professional overhead presentations. Do not use normal transparencies in the C3500, as they do not absorb ink and can cause the ink to run.

Canon Back Print Film BF-102

This unique mylar-based translucent sheet allows you to print high-quality letter-size color output — including photographs and graphics — that you can view with a rear illumination device such as with a light box. This gives you sharp, bright, vivid images you can use in meetings, trade shows, and other presentations.



Note

If you are printing from an application outside Windows, your application or printer driver must support mirror image printing in order to use back print film.

Canon High-Gloss Film HG-101

This is a high-grade, letter-size gloss film that lets you create sharper and more vivid color output than is possible with coated paper. This film provides the best color print quality for the BC-21 Color BJ cartridge. Use this film for trade show displays or other special presentations, and when printing at 720 x 360 dpi resolution.

Fabric Sheets FS-101

These legal-size, white, cotton fabric sheets are specifically designed for Canon BJ Color printers, and enable you to print your own designs for cross stitch, pillows, holiday stockings, and other craft projects.

T-Shirt Transfers TR-101

This special letter-size sheet allows you to print your own designs and transfer them to any cotton or cotton/poly blend t-shirt, sweatshirt, apron, tote bag, or other fabric item.



Be sure to select Back Print Film Option when printing on the TR-101 T-Shirt Transfers. See the *MultiPASS Desktop Manager for Windows® User's Guide* for instructions.

Setting Up Your
C3500

The Printable Area

To ensure the best print quality, make sure the text or graphics you create stay within the printable areas shown below. If not, you can get poor print quality or line feeding problems. (For example, printing outside the bottom margin can produce stains on the bottom edge of the medium.)

Plain Paper and Special Media

The shaded area in the figure below shows the printable area for papers.

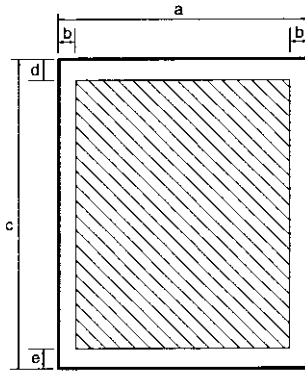

Printable Area:

Letter size	Legal size	A4 size
a 8.5 in	a 8.5 in	a 210 mm
b 0.13 in	b 0.13 in	b 3.4 mm
c 11.0 in	c 14.0 in	c 297 mm
d 0.12 in	d 0.12 in	d 3.0 mm
e 0.27 in	e 0.27 in	e 7.0 mm

Envelopes

The shaded portion below shows the printable area for envelopes.

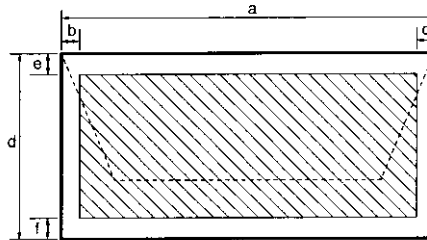

Setting Up Your
C3500

Printable Area:

U.S. Commercial No. 10

a	9.5 in
b	0.25 in
c	1.2 in
d	4.1 in
e	0.12 in
f	0.27 in

European DL

a	220 mm
b	6.4 mm
c	10.4 mm
d	110 mm
e	3.0 mm
f	7.0 mm

Adjusting the Paper Thickness Lever

Before loading a print medium into the C3500, use the paper thickness lever to adjust the gap between the print head and the print paper to suit the paper's thickness.



Note

If the gap between the print head and the paper is not adjusted properly, smudging or otherwise poor print quality can result.

Set the paper thickness lever as follows:

CARTRIDGE



1. Press **CARTRIDGE** to move the cartridge holder to the center of the unit.
2. Open the printer cover by grasping the document guides and lifting.

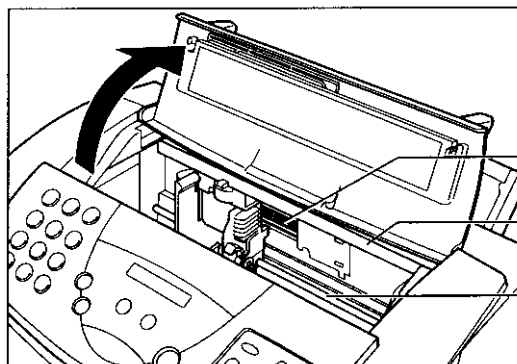

Caution

Do not try to move or stop the cartridge holder manually, or you may damage the C3500.

3. Set the paper thickness lever to left, center, or right according to the following table:

Medium	Lever position	
	Black	Color
Plain paper	Left	Center
LC-301 water resistant paper	Left	Center
Envelopes		Right
HR-101 high-resolution paper		Center
GP-101 glossy paper		Center
CF-102 transparencies		Center
BF-102 back print film		Center
HG-101 high-gloss film		Center
FS-101 fabric sheet		Right
TR-101 T-shirt transfers		Right

Setting Up Your
C3000

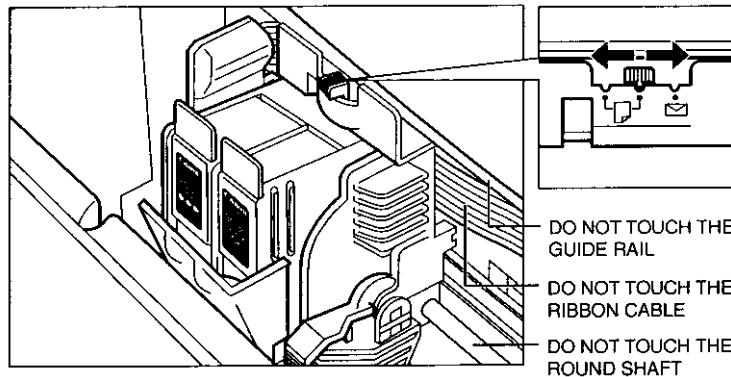

Caution

Do not try to manually move or stop the cartridge holder, or you may damage the C3500.



4. Close the printer cover.
5. Press **CARTRIDGE** again to move the cartridge holder back to its home position.

Loading the Print Media

Keep the following in mind when selecting or loading media for your C3500:

- ❑ You can stack plain paper, envelopes, and other media in the C3500's sheet feeder. The maximum size of the stack depends on the medium:

Medium	Maximum stack size
Plain paper	100 sheets
Envelopes	15 envelopes
Transparencies	50 sheets
Back print film	10 sheets

- ❑ To avoid paper jams and poor print quality, never try to print on damp, curled, wrinkled, or torn paper.
- ❑ Store paper and other media flat, and leave it in its wrapper until you are ready to use it. Store unused paper from opened packs in the original packing in a cool, dry location.
- ❑ Store paper at 64–75 °F (18–24 °C), 40–60% relative humidity.
- ❑ If you have trouble with sheets skewing, double-feeding, or jamming when using coated paper, transparencies, or back print film in the sheet feeder, use manual feeding instead. (These problems are more common at cooler temperatures.)
- ❑ Let the paper run out before you refill the tray. Avoid mixing “new” paper with paper remaining in the tray.
- ❑ Use cut-sheet paper only, not paper that comes on a roll (like fax paper).
- ❑ When using graph paper, the lines may not match because the 1/6-inch line spacing of the C3500 is slightly less than that of graph paper.
- ❑ If the print density of your page is very high, light paper stock may curl slightly due to the large amount of ink. If you need to print dense graphics, try printing on heavier stock.
- ❑ Do not use paper that is thicker than specified for the C3500. Printing with a paper that is thick enough to come in contact with the print head nozzles may damage the BJ cartridge. For complete paper specifications, see “Printer” on page A-2.

Loading Print Media for Automatic Feed

The C3500's sheet feeder can handle media of the following sizes:

Paper size:	A4	210 x 297 mm
	Letter	8.5 x 11 in
	Legal	8.5 x 14 in
	European DL envelopes	220 x 110 mm
	U.S. Commercial No. 10 envelopes	9.5 x 4.1 in
Paper weight:	17–24 lbs (64–90 g/m ²)	

Paper or other media

Use the following procedure to load plain paper, CF-102 transparencies, BF-102 back print film, or HR-101 high-resolution paper into the C3500's sheet feeder. (Instructions for other media are given in the following pages.)

1. Open the printer cover by grasping the document guides and lifting.
 - Make sure the paper thickness lever is set properly for the type of media you are using. See "Adjusting the Paper Thickness Lever" on page 2-38.



To avoid paper jams, smearing, or other problems, never open the printer cover to set the thickness lever, while the C3500 is printing.

2. Pull the paper rest up until it stops.

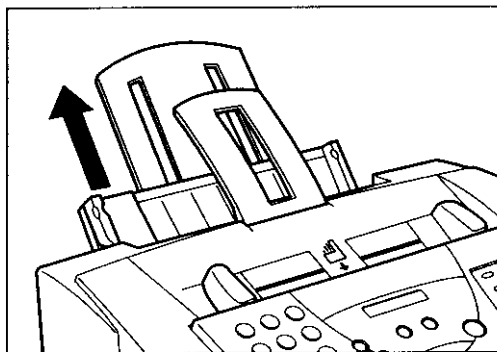

3. Pick up a stack of sheets and fan the edge that will feed into the C3500 first, then tap the stack on a flat surface to even its edges.

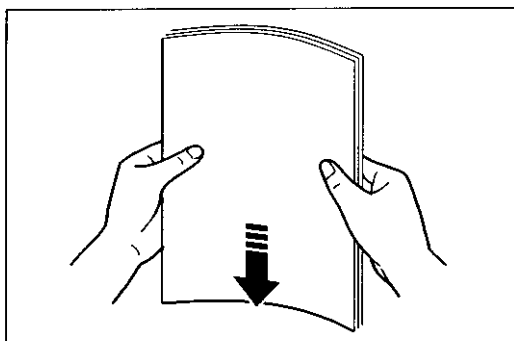

4. Insert the stack into the sheet feeder until its stops, so that the right edge of the stack is aligned with the right side of the sheet feeder.





Note

Make sure the top of the stack is below the paper limit mark (▲).

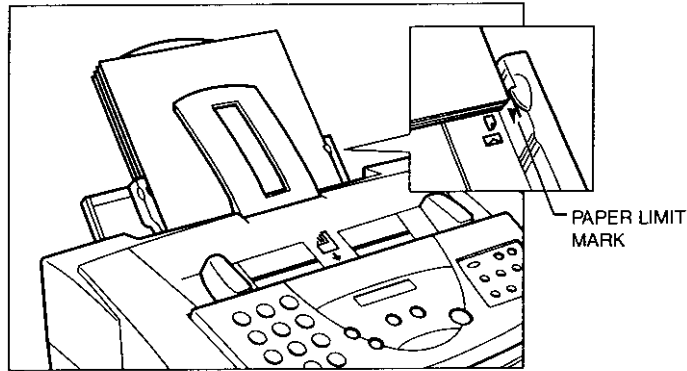

Setting Up Your
C-3500

5. Slide the paper guide snugly against the sides of the stack. You are now ready to print.



Note

- ❑ Many media have a “right” side for printing. If you are using such a medium, make sure you set it in the sheet feeder with the print side facing upward:
 - BF-102 back print film: matte side up
 - HR-101 high-resolution paper: lighter side up
- ❑ After printing a pack of HR-101 high-resolution paper, be sure to use the provided cleaning sheet to clean the C3500's printer roller, see “Printing on High Resoluion Paper HR-101” on page 2-46.

Glossy paper

Use the following procedure to load GP-101 glossy paper.



Note

For best results, load only one sheet of glossy paper into the sheet feeder at a time.

1. Open the printer cover by grasping the document guides and lifting.
 - Make sure the paper thickness lever is set to the center. See "Adjusting the Paper Thickness Lever" on page 2-38.
2. Close the printer cover.
3. Pull the paper rest up until it stops.
4. Insert a sheet of glossy paper — with the glossy side facing up — into the sheet feeder until it stops, and align the paper guide with the edge of the sheet.

Loading Print Media for Manual Feed

Follow the steps below to manually feed heavier-weight media (24–28 lbs/90–105 g/m²) into the C3500.



Note

You will need to select manual feed from the print dialog box of your Windows application before printing. (See the *MultiPASS Desktop Manager for Windows® User's Guide* for instructions.) Load the sheet when the dialog box prompts you to do so. If you attempt to load the sheet without selecting manual feed, the sheet will be ejected.

1. Open the printer cover by grasping the document guides and lifting.
 - Make sure the paper thickness lever is set properly for the type of media you are using. See "Adjusting the Paper Thickness Lever" on page 2-38.
2. Hold the sheet with its print side facing upward, and align the sheet with the left edge of the manual feeder (located at the back of the unit).
3. Insert the sheet until it stops, and continue to hold the sheet until the C3500 "grabs" the sheet and pulls it in to the proper position.

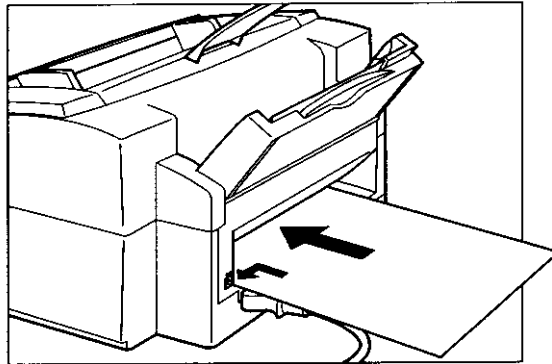

4. After the sheet is loaded, open the printer cover and make sure the sheet is set straight. If necessary, pull the sheet out and load it again.
5. Close the printer cover.

Using Canon's Specialty Papers

Canon provides several different specialty papers you can use with your C3500.

Printing on High Resolution Paper HR-101

Use the following procedure to load High Resolution Paper HR-101:

1. Open the printer cover by grasping the document guides and lifting.
 - Make sure the paper thickness lever is set to the center. See "Adjusting the Paper Thickness Lever" on page 2-38.
2. Close the printer cover.
3. Pull the paper rest up until it stops.
4. Load the paper into the sheet feeder as described in "Loading Print Media for Automatic Feed" on page 2-41.
5. Raise the output guides as described in "Using the Paper Output Guides with the BC-22 Cartridge" on page 2-49.
6. When you are finished printing, remove the remainder of the HR-101 paper from the sheet feeder.
7. The HR-101 package includes a cleaning sheet. Remove the two pieces of tape from this sheet.

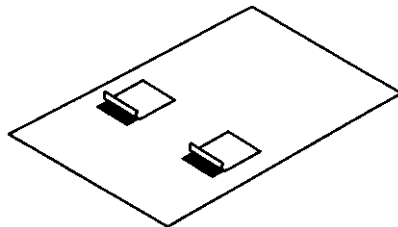

8. Insert the cleaning sheet with the sticky side up and pointing down.

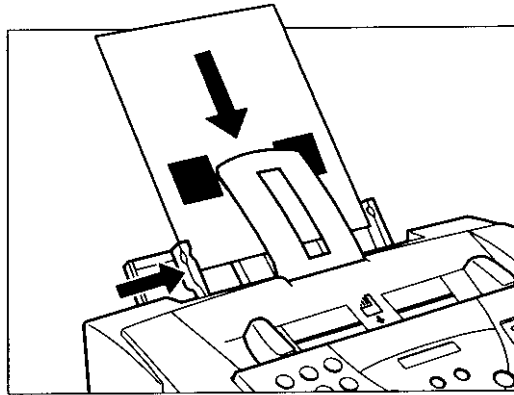

Setting Up Your
C3500

9. Align the sheet with the right edge of the sheet feeder and slide it into the unit until it stops.
10. Adjust the paper guide to the edge of the cleaning sheet.
11. Press **RESUME** to advance the cleaning sheet and set it.
12. To start cleaning, press **RESUME** again.
 - The cleaning sheet feeds through the unit and ejects.

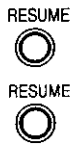

This completes the roller-cleaning process.

Printing on FS-101 Fabric Sheets

Follow these steps to load and print on Canon's FS-101 fabric sheets.



- Read and follow the precautions and handling instructions included with the FS-101 fabric sheets.
- Do not use the fixing agent that is supplied with the FS-101 fabric sheet. This agent is not needed when printing with the C3500.
- Do not touch the printing on a newly printed fabric sheet until the ink has dried completely (normally about an hour).

1. Open the printer cover by grasping the document guides and lifting.
 - Make sure the paper thickness lever is set to the right. See "Adjusting the Paper Thickness Lever" on page 2-38.
2. With the cloth side facing you and the open end up, insert one sheet into the sheet feeder until it stops, and align the paper guide with the edge of the sheet. You are now ready to print.

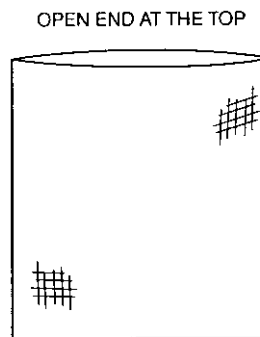
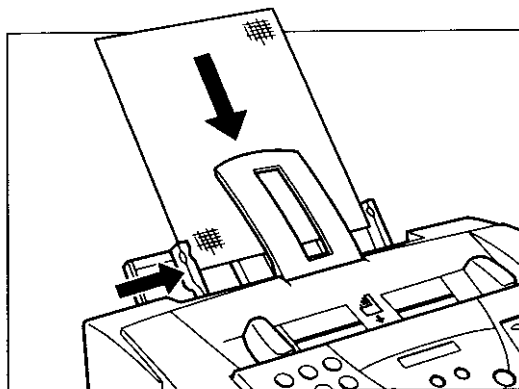

Using the Paper Output Guides with the BC-22 Cartridge

When printing with the BC-22 Photo Color BJ cartridge on HR-101 high-resolution paper, you should use the guides on the C3500's paper output tray to help support the document as it exits the unit. This will keep the sheet from sagging as it exits and pulling through the unit, which can lead to poor print quality.

1. Raise both paper output guides until they are vertical.

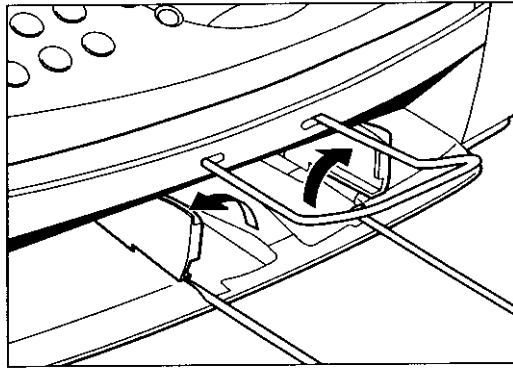

Note

- Always raise both paper output guides.
- Always use the paper output guides when printing on HR-101 high-resolution paper, even when using the BC-20 or BC-21 cartridges.

2. When you finish using the BC-22 cartridge, return the paper output guides to their original position.



Note

When the paper output guides are raised, the output tray can hold a maximum of 20 sheets. Always lower the paper output guides when using the C3500 as a fax machine, or they can cause the faxes to pile up and jam.

Entering User Information in the C3500

FCC rules governing the use of fax equipment require you to include your name or company name, your fax number, and the date and time of transmission on each fax you send. This information is called your Transmit Terminal Identification, or TTI, and appears at the top of the received fax in small type.

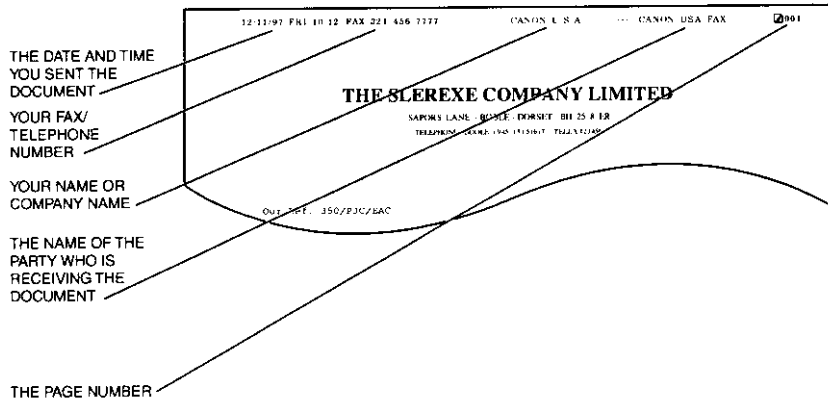

You must enter this information before using your C3500. There are two ways to do this:

Method 1: C3500 Operation Panel

You can enter the user information directly into the C3500 using the instructions on the following pages. This allows you to use the C3500 as a fax machine even if you do not have a PC connected to it.

Method 2: MultiPASS Desktop Manager

You can also enter the user information using the MultiPASS Desktop Manager. Entering information in this way will override any information entered directly into the C3500. See the *MultiPASS Desktop Manager for Windows® User's Guide* for more information.



Note

The top line of your faxes also include the name of the receiving party when you use one-touch speed dialing, coded speed dialing, or group dialing.

Guidelines for Entering Information

Follow these guidelines for entering user information into the C3500:

If you pause while entering information and do not make an entry for more than 60 seconds, the C3500 returns to Standby mode and loses all information you had entered up to that point. You will then have to start over.



Note

If the C3500 rings while you are entering information, press **STOP** and lift the handset on the extension phone: The C3500 will automatically save all the information you have entered up to the last time you pressed **START/COPY**.

- If you hear nothing or a slow beep, someone is trying to send a fax: press **START/COPY**.
- If you hear a voice, you are receiving a normal telephone call.
- If your C3500 is set to receive faxes automatically, you do not have to press **STOP**, the C3500 will automatically receive the fax. See "Receiving Faxes" on page 5-16.

Setting Up Your
C3500



Entering a Name

When entering a name (such as "Unit Name"), each numeric button has a number and a group of uppercase and lowercase letters assigned to it. The chart below shows which number to press for each character.

Button	Characters
1	1
2	ABCabc2
3	DEFdef3
4	GHIghi4
5	JKLjkl5
6	MNOmno6
7	PQRSpqrs7
8	TUVtuv8
9	WXYZwxyz9
0	0
#	-.*#!'";:^^_=/ '?\$@%&+()[]{}<>

Entering a single letter

For example, you would enter a lowercase letter **b** like this:

Operation:  

Display: A → B → C → a → b

Entering two letters from the same group

To enter two letters from the same group, you have to use the right cursor button (>). For example, you would enter **AA** like this:



1. Press 2 once to display the first A.





2. Press the right cursor button (>) to enter the A and move the cursor to the right.

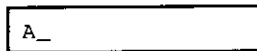



3. Press 2 again for the second A.

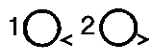

Editing Information

- If you make a mistake while entering a name, you can correct it by using the < and > buttons:
 1. Use the > button to scroll to the incorrect character.
 2. Press the < button once to erase the character above the cursor. (The cursor moves one space to the left.)
 3. Press the > button to move back to the empty space and type in the correct character.



- You can also press the **STOP** button to cancel and re-enter the information in the current category (DATE & TIME, UNIT NAME, UNIT TELEPHONE, etc.)