

Plockmatic BLM 35/50 Production Booklet Maker

Operator Manual



Please read this manual carefully before you use this product and keep it handy for future reference.
For safety, please follow the instructions in this manual.

Doc no: X04107E
Date: 26 June 2017

Electromagnetic compliance

This product complies with EU Standard EN 55032:2015, Class A.

Operation of this equipment in a residential environment could cause radio interference.

NOTE:

The domestic environment is an environment where the use of broadcast radio and television receivers may be expected within a distance of 10m of the apparatus concerned.

Introduction

This manual contains instructions on the operation and maintenance of this machine. To get maximum versatility from this machine all operators should carefully read and follow the instructions in this manual. Keep this manual in a handy place near the machine.

Please read the Safety Information before using this machine. It contains information related to USER SAFETY and PREVENTING EQUIPMENT PROBLEMS.

How to read this manual

Notation conventions

Whenever necessary, the following points for attention are indicated in this manual.

WARNING

Indicates a potentially hazardous situation which, if instructions are not followed, could result in death or serious injury.

CAUTION

Indicates a potentiality hazardous situation which, if instructions are not followed, may result in minor or moderate injury or damage to machine or property.

NOTE:

This sign refers to:

- *Remarks for making the operation much easier. You get practical hints or knowledge to assist you in the machine operation such as:*
- *Preparations required before operating*
 - *How to prevent papers from being misfed or damaged*
 - *Precautions required or actions to take after misoperation*
- *Limitations like numerical limits, functions that cannot be used together or conditions, under which a particular function cannot be used or obtained.*
- *Information.*

[]

Keys that appear on the machine's display panel.

Safety Information

When using this machine, following safety precautions should always be followed.

Safety during operation

WARNING

- To avoid hazardous situations like for instance electric shock or danger while exposed to moving, rotating or cutting devices, do not remove any covers, guards or screws other than those specified in this manual.
- Turn off the power and disconnect the power plug (by pulling the plug, not the cable) if any of the following conditions exists:
 - You drop objects or spill something into the equipment.
 - You suspect that your equipment needs service or repair.
 - Your equipment's covers has been damaged.
 - You notice unusual noises or odours when operating the equipment.
 - If the power cable or plug becomes worn out or otherwise damaged.
 - Before cleaning and care (unless otherwise specifically instructed).
- Electromagnetic compliance:
 - This is a Class A product. In a domestic environment this product may cause radio interference in which case the user may be required to take adequate measures.
 - The product (System) which is connected to this machine will be class A.

General safety

WARNING

- Always connect the equipment to a properly grounded power source (wall outlet). If in doubt, have the power source checked by a qualified electrician.
- Improper grounding of the equipment can result in electrical shock. Never connect the machine to a power source that lacks a ground connection terminal. This machine is destined for specific purpose only. Any use going beyond this specific purpose is regarded as beyond the determination. The manufacturer will not be liable for damages resulting from any use beyond the determination, unallowed operation, respectively. The user alone bears the risk.
- Do not make arbitrary changes or modifications to the machine. The manufacturer will not be liable for modifications made at the machine on your own and damages resulting thereof. EC declaration of conformity and the mark CE will be invalidated, if you make changes at the machine or at the individual components.
- Do not override or bypass electrical or mechanical interlock devices.
- The machine is to be used only by authorized and instructed persons. The responsibilities on operating the machine have to be strictly laid down and observed so that there are no unclear competences regarding safety aspects.
- Vent holes serve for air circulation to protect the machine from overheating. Make sure that the holes are not covered.
- Do not expose fingers or other parts of the body to moving, rotating or cutting devices such as for instance between upper and lower trimmer knives.
- Always locate the equipment on a solid support surface with adequate strength for the weight of the machine.

General safety, continued

CAUTION

- *The machine and its peripherals must be installed and maintained by a customer service representative who has completed the training course on those models.*
- *Always follow all warnings marked on, or supplied with, the equipment.*
- *When you disconnect the power plug from the wall outlet, always pull the plug (not the cable).*
- *Disconnect the power cord before you move the machine. While moving the machine, always exercise care and make sure that the power cord will not be damaged under the machine.*
- *Always contact service if relocating the equipment.*
- *Do not move the machine while the machine is running.*
- *Do not open covers while the machine is running.*
- *Do not switch off the power while the machine is running. Make sure the machine cycle has ended.*
- *Lay the power cord in a way that nobody will stumble over it. Do not place things on the cord.*
- *Never attempt any maintenance function that is not specifically described in this documentation.*
- *Always keep magnets and all devices with strong magnetic fields away from the machine.*
- *If the place of installation is air-conditioned or heated, do not place the machine where it will be:*
 - *Subject to sudden temperature changes.*
 - *Directly exposed to cool air from an air-conditioner.*
 - *Directly exposed to heat from a heater.*
- *If the machine is not used over an extended period of time it should be unplugged to prevent damage in the case of overload.*

NOTE:

- *The indications like front and rear, left and right refer to the paper transport direction.*
- *The operator manual always has to be available at the place of use of the machine.*
- *In the interest of technical development the company reserves the right to make alterations to specifications without prior notice!*

Page intentionally blank.

TABLE OF CONTENTS

What You Can Do With This Machine	11
Guide to Components	13
Booklet Maker	13
User Interface	16
Control Panel.....	16
Options	19
Rotate Crease Trim Module.....	19
Booklet Maker	24
Alive Logo.....	24
Cover Feeder	25
BookFold Module	26
Trimmer.....	28
BST4000-1 Belt Stacker Module	30
BST4000-1 Principle of Operation.....	31
1. Basics	33
Turning On / Off the Main Power	33
RCT, Booklet Maker, BookFold Module, Trimmer & BST Module.....	33
Change staple cartridges and Check Stapler	34
Change left/right staple cartridge(s).....	34
Check left/right stapler	35
Cover Feeder	35
Loading covers	35
Emptying the trim waste bin	36
Belt Stacker	37
Setting up Belt Stacker for right-angled mode	37
Setting up Belt Stacker for straight mode	38
2. Making Booklets	39
Guided Start	39
Guided Start, step by step	39
Changing settings	42
General procedure.....	42
Basic settings	42
Input Sheet Size	42
Selecting standard paper sizes	42
AUTO sheet size	43
Custom input sheet size.....	43
Finished Booklet Size	43
Auto trimming	43
Custom booklet size	44
Customizing settings	45
Staple.....	45
Selecting stapling On or Off	45
Adjusting staple position.....	45
Fold position	46
Adjusting fold position	46
Cover	46
General.....	46
Cover.....	47
Air Separation.....	47
Double Sheet Detection	47
Purge Cover	48

BookFold.....	48
General.....	48
Selecting BookFold pressure setting.....	49
Crease	50
Crease Mode.....	50
Crease position	50
Fine-tuning booklet appearance	51
Set registration (fine adjustment)	51
Bleed Trimmer - Asymmetric Side Trim.....	52
Bleed Trimmer - Cover Adjust	52
Hand-feeding.....	53
Hand feed mode	53
3. Tools	55
The Tools screen.....	55
Stacker full detection	55
Units.....	55
Software version	56
Paper path light.....	56
Language	56
Service mode.....	57
Fold delay	57
Sheet feeder	57
Auto Rotate.....	58
BookFold offset.....	58
4. Jobs	59
Handling jobs.....	59
Saving a Job	59
Opening and handling stored Jobs	60
5. Clearing Misfeed(s)	61
Clearing misfeed(s)	61
General	61
RCT Module.....	62
Clearing misfeed(s).....	62
Infeed “A” area and exit “D” area.....	62
Registration and creaser area.....	63
Booklet Maker	64
Clearing misfeed(s).....	64
Inside the Booklet Maker	64
Clearing misfeed in infeed area.....	65
Clearing misfeed in folder area	66
Cover Feeder.....	67
Clearing misfeed(s) in vertical transport area	67
BookFold Module	68
Clearing misfeed(s).....	68
Inside the BookFold Module.....	68
Trimmer	69
Clearing misfeed(s).....	69
Clearing misfeed in input area.....	69
Clearing misfeed in exit area.....	70

Belt Stacker	71
Clearing misfeed(s).....	71
Clearing misfeed on belt stacker.....	71
6. Troubleshooting	73
Fault codes	73
General.....	73
RCT fault codes.....	73
Booklet Maker fault codes.....	74
Cover Feeder fault codes.....	75
BookFold Module fault codes.....	76
Trimmer fault codes.....	77
Belt stacker fault codes.....	77
General fault codes.....	78
Clear Misfeed(s).....	78
Close cover(s).....	78
Empty stacker!.....	78
7. REMARKS	79
Do's And Don'ts	79
Where to put Your Machine	80
Machine environment.....	80
Power connection.....	80
Access to machine.....	81
Maintaining Your Machines	82
Cover Feeder.....	82
Cleaning feed rollers and paper separator pad.....	82
BookFold Module.....	83
Cleaning feed belts.....	83
Pressure springs.....	84
RCT Module.....	85
Cleaning the paper path transportation nip rollers (12x).....	85
Cleaning the fixing rollers (3x).....	86
Cleaning the registration cross roller (4x) & friction tires (4X).....	87
Cleaning the rotator rollers (2x).....	88
Cleaning the paper path sensors (5x).....	88
Cleaning of creaser tools (2x).....	90
Adjustment of Bleed Trimmer registration angle (parallel cut).....	91
Adjustment of Creaser registration angle.....	92
Best practices for the BLM 35/50 system	93
Limitations of the BLM 35/50 system	94
8. Specification	97
Machine Specifications	97
Rotate Crease Trim Module (option).....	97
Booklet Maker.....	98
Cover Feeder Module.....	99
Trimmer Module.....	99
BookFold Module.....	100
BST4000-1 Belt Stacker Module.....	100
System Set Size Guide.....	101
Cables, plugs and jumpers.....	105
INDEX	106

Page intentionally blank.

What You Can Do With This Machine

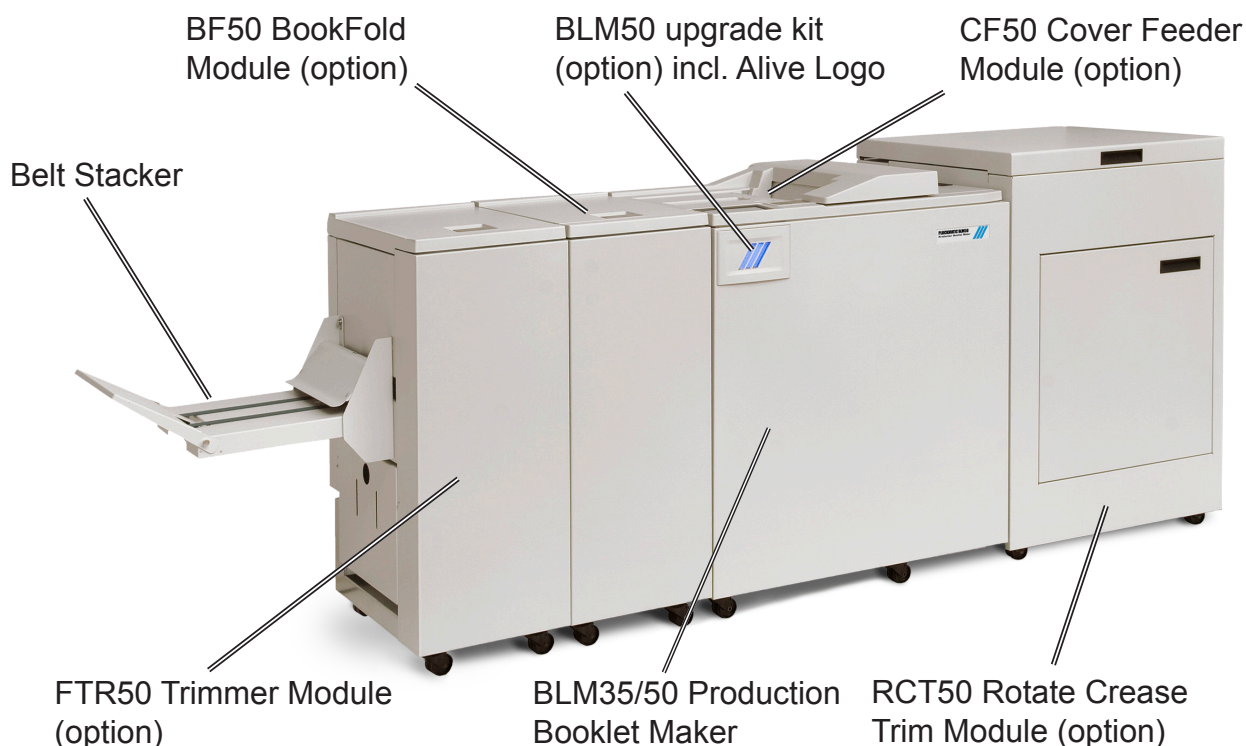

The Plockmatic BLM50 or the Plockmatic BLM35 Production Booklet Maker System consists of:

Rotate Crease Trim Module (optional), also referred to as the RCT Module or the RCT

Cover Feeder Module (optional), also referred to as the Cover Feeder or the CF

BookFold Module (optional), also referred to as the BookFold or the BF

Trimmer Module (optional), also referred to as the Trimmer or the TR

BST4000-1 Belt Stacker Module (optional), also referred to as the BST Module or the BST

Together they form a system that allows full bleed booklet making online with the Printer.

A capacity enhancement is the BLM50 upgrade kit. This kit increases the capacity of the BLM35 Booklet maker from 35 sheets to 50 sheets. This means that instead of 140 page booklets, 200 page booklets are now possible. The BLM50 upgrade kit also includes the Live logo feature. The logo below the user interface will be illuminated, allowing the user to monitor the system status from a distance.

The print-outs first enter the Rotate Crease Trim Module. The RCT Module is able to rotate small(er) sheets from long edge feed to short edge feed to maintain high printer productivity. In order to avoid toner cracking at the spine when folded, the RCT can be programmed to crease the cover sheet. The RCT can also trim the long sides of the booklet sheets to deliver booklets in the desired size. To enable full bleed booklets, a Trimmer Module must be installed after the Booklet Maker, see below.

From the RCT, the printed sheets are transported into the BLM50 or BLM35 Production Booklet Maker where they are compiled in the stapler area.

If a Cover Feeder Module is installed in the Booklet Maker, it can add any type of cover, in colour or black and white, to the printed set. The Booklet Maker jogs and staples the set.

continued on next page

continued from previous page

The set is then transported further into the Booklet Maker to the folding area where the set is folded into a booklet and delivered out to the belt stacker or a downstream module.

After the Booklet Maker, an optional BookFold Module can be attached. The stapled and folded books will be fed into the BookFold Module where the spine of the booklets are flattened square. The booklets will now have the look of a perfect bound book. Finally, the booklets are fed out to the optional Trimmer or directly to a Belt Stacker.

When a larger number of sheets are folded, an effect called creeping occurs. In order to eliminate creep, an optional Trimmer Module can be attached after the Booklet Maker or BookFold Module. The booklets are transported from the Booklet Maker or BookFold Module into the Trimmer where the front edge will be cut off. The Trimmer combined with an RCT Module in front of the Booklet Maker creates the possibility to create full bleed booklets.

To allow longer, unattended runs there is an optional high capacity belt stacker available. The BST4000-1 Belt Stacker Module will stack up to 1000 A4 or 8,5 × 11" booklets of 4 pages.

In addition to producing booklets inline, it is possible to use the Booklet Maker System for hand-feeding.

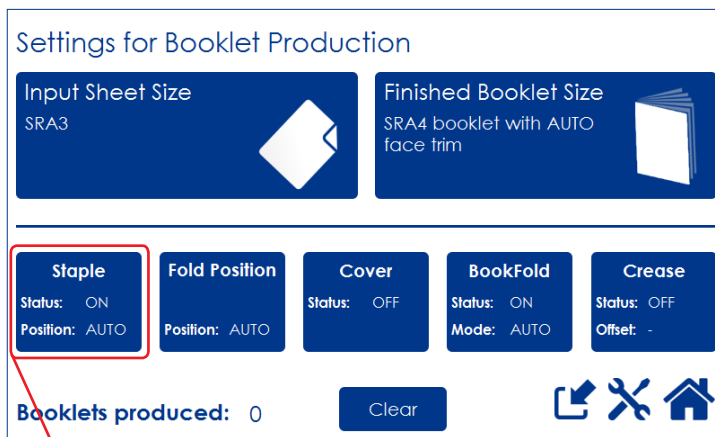

The user interface/control panel is of touch screen type. Point at the screen and press the button or function you wish to make changes to. In this sample screen shot, the Staple button is pressed.

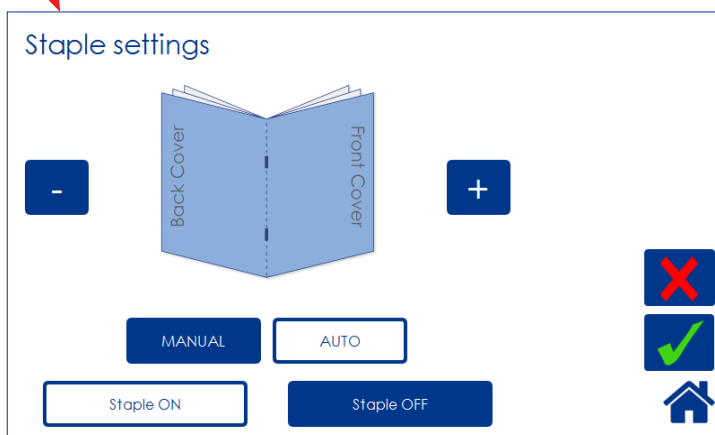

A sub screen is shown. Make your changes and confirm by pressing the green check mark or exit without making any changes by pressing the red X. Pressing the home symbol takes you back to the main or home screen.

Guide to Components

Booklet Maker

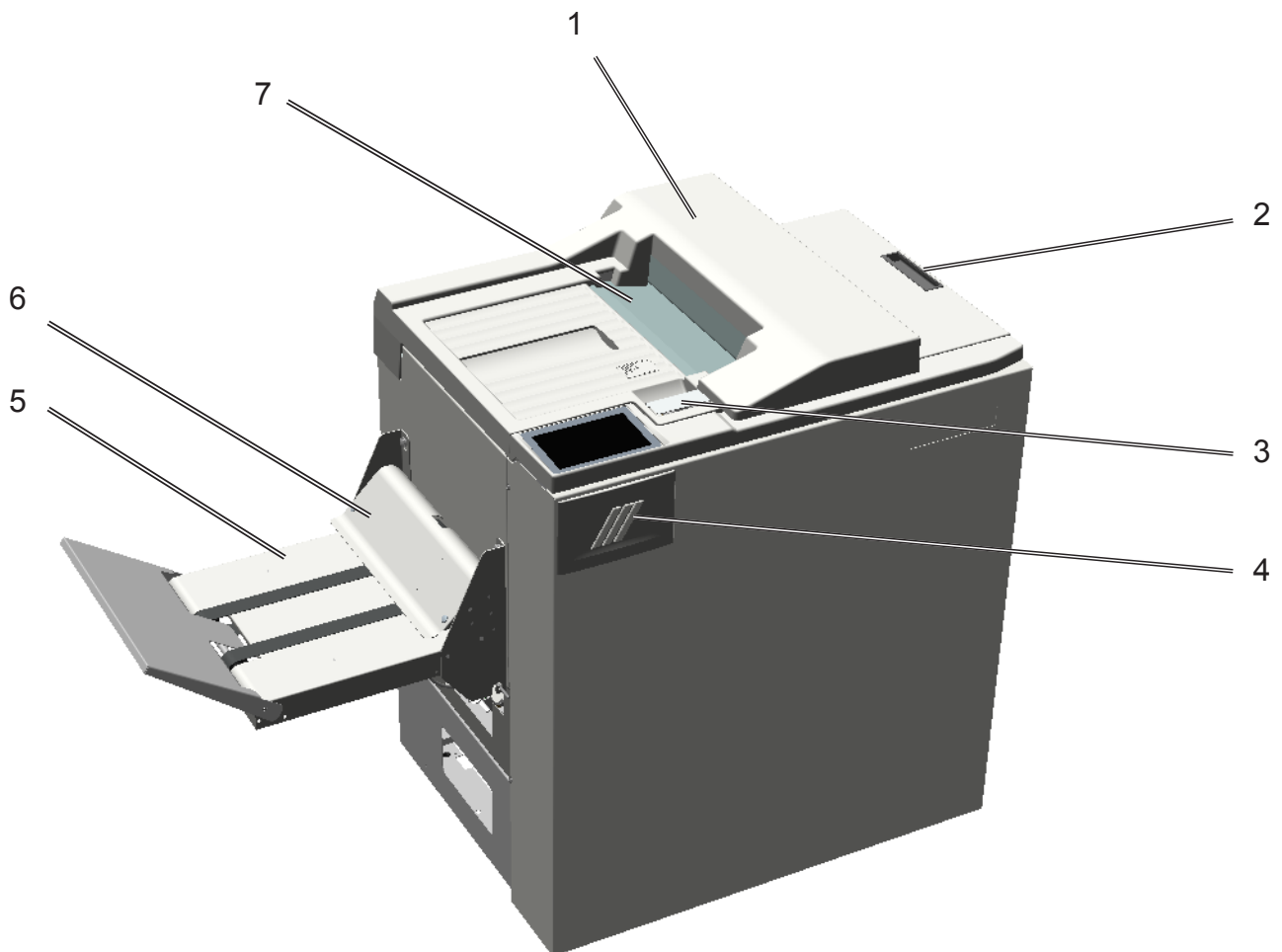

1. Top cover
2. Cover for Hand Feed
3. Latch handle
4. Live Logo, only on 50 sheet option
5. Belt Stacker
6. Belt Stacker Cover
7. Slot for optional Cover Feeder

Booklet Maker, continued

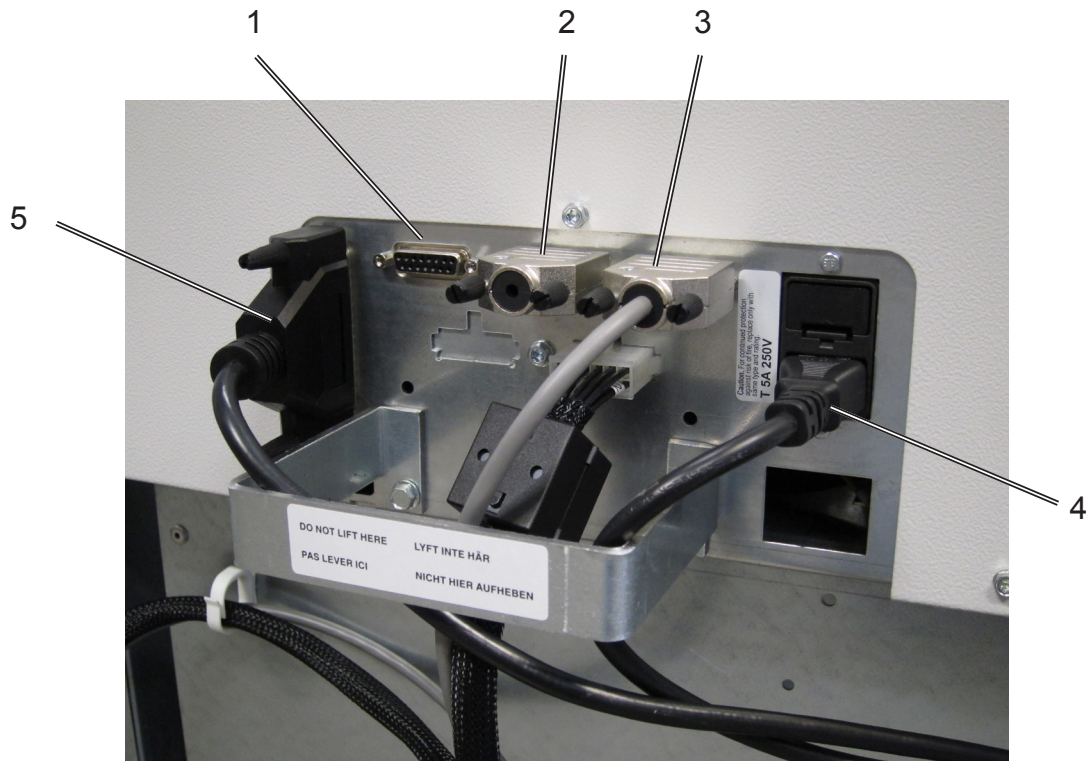

1. Belt Stacker Connector
2. Upstreams Communication
3. Downstreams Communication
4. Power Connection
5. Printer interface

 **NOTE:**

How to connect cables, plugs and jumpers is described at the end of this manual.

Booklet Maker, continued

Parts that are important for setup, adjustments, troubleshooting or maintenance are highlighted below.

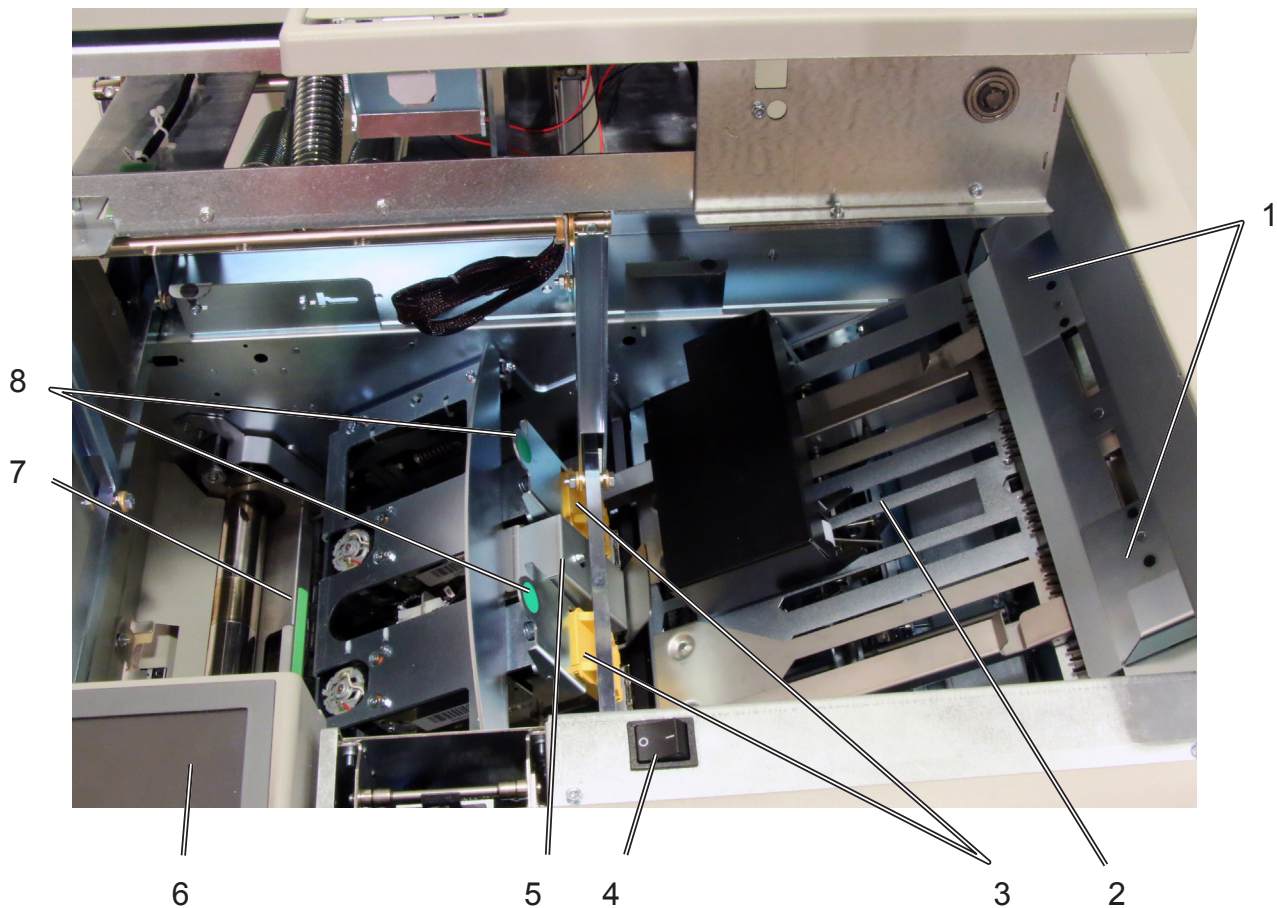

1. Hand feeding paper guides
2. Compiler area
3. Staple cartridges (incl. stapler heads)
4. Main power switch
5. Set thickness sensor
6. Control panel
7. Fold roller guide
8. Staple cartridge ejection lever

User Interface

The Plockmatic BLM50 or BLM35 Production Booklet Maker System is controlled from a panel located on the Booklet Maker. The control panel will allow you to set up, adjust and operate the complete system. An optional “Alive logo” makes the state of system visible from a distance.

 **NOTE:**

Depending on modules and features installed, the screen may look different from what you see here. Some functions are greyed out or not visible at all and remaining buttons may stretch to fit the screen. This manual will most often show a fully configured system.

Control Panel

The control panel is of touch screen type. Point at the screen and press the “button” to reach the desired function or change the desired setting.

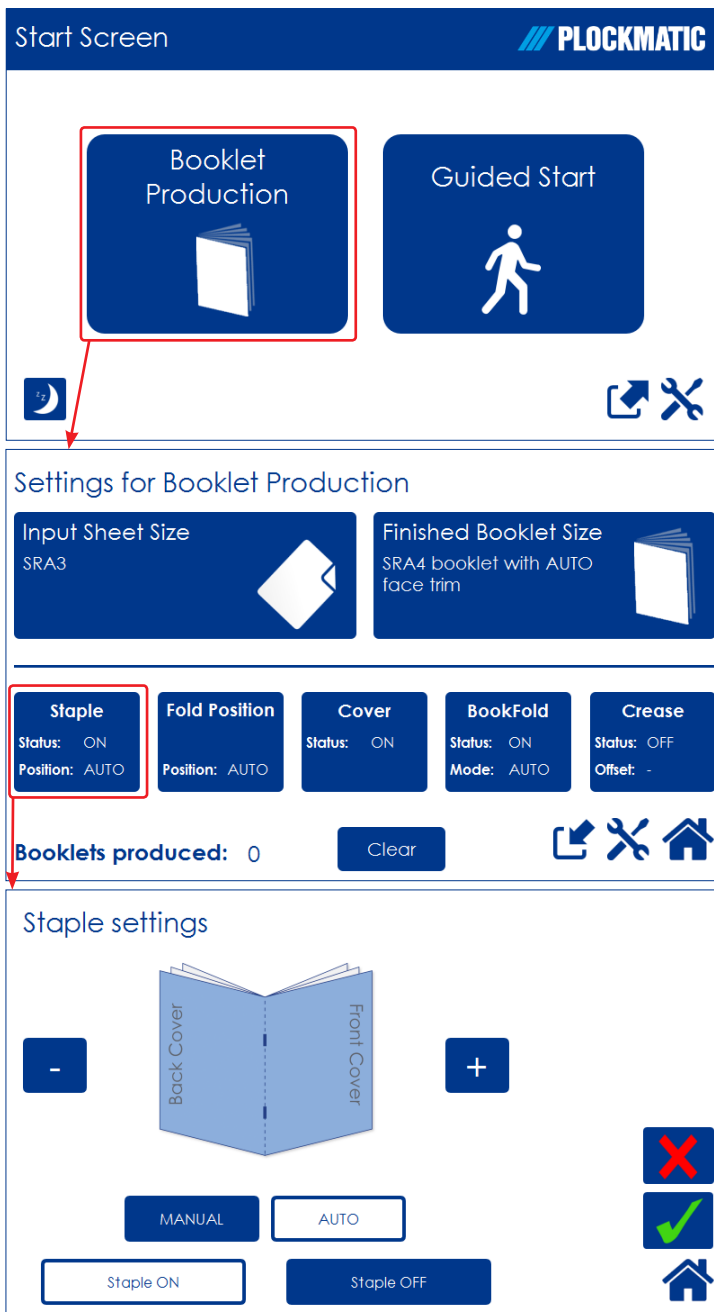

The Start Screen

When the system power is switched on, the Start screen will be shown. From here you can choose to set up Booklet Production, perform a Guided Start, retrieve stored jobs or access the General System Settings.

Settings for Booklet Production

Pressing the [Booklet Production] button in the Start Screen opens the Settings for Booklet Production screen. From here you can reach all detailed settings for setting up the job.

A counter shows the number of booklets produced. Clear will reset.

Detailed Settings

Pressing, for example, the [Staple] button in the Settings for Booklet Production screen opens the Staple settings screen. Here you can perform detailed settings concerning stapling. Explore this and other settings more thoroughly in section 2, “Making Booklets.”

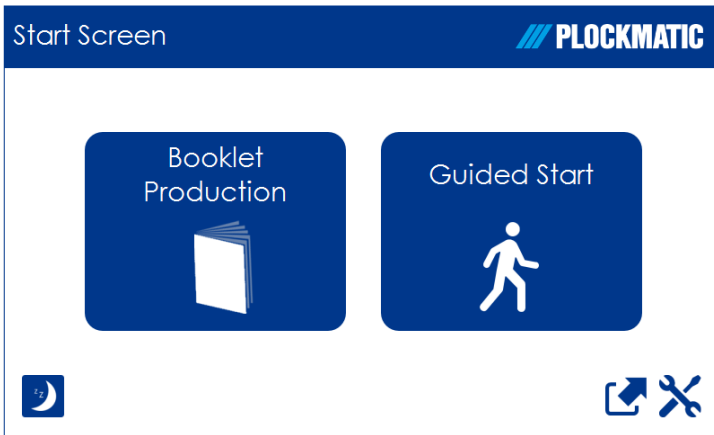

Guided Start

Guided Start is a function that takes you through all the basic settings the Booklet Maker System needs for booklet production in eight easy steps.

See “Guided Start” in section 2 “Making Booklets” for details.

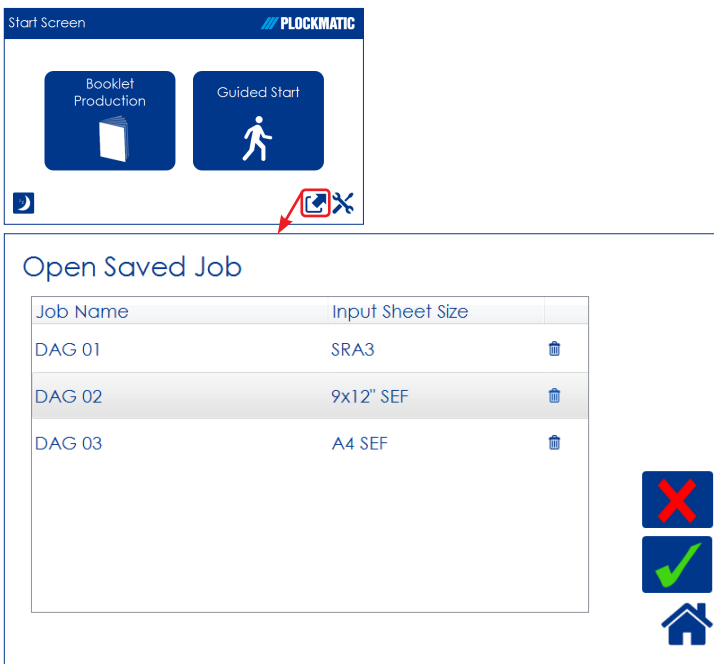

The Jobs Screen

Pressing the [Open Jobs] button in the Start screen opens the Open saved Job screen. From here you can open a saved job. Jobs can be stored, deleted, customized etc. Handling jobs is described in section 4, “Jobs”.

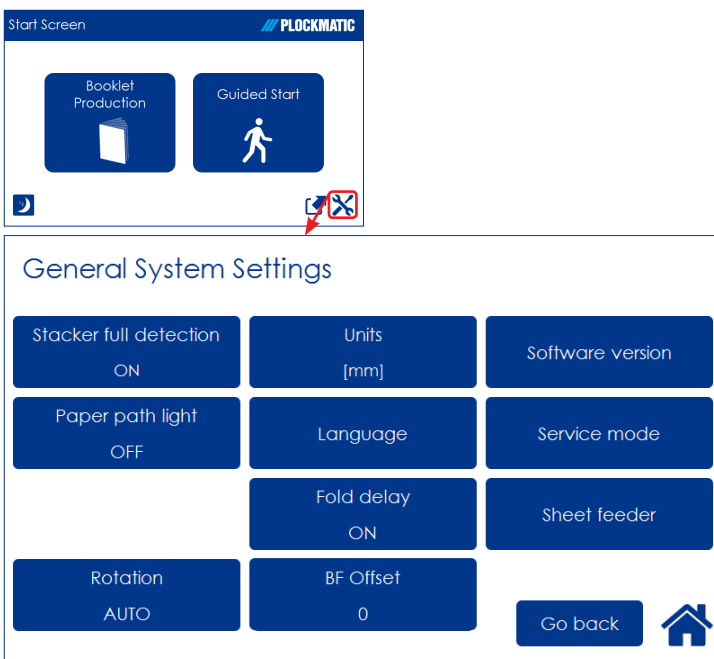

General System Settings

Pressing the [Tools] button opens the General Systems Settings screen. From here you can change basic settings like the display language, setting units from millimeters to inches and more. See section 3, “Tools” for how to work with the Tools screen.

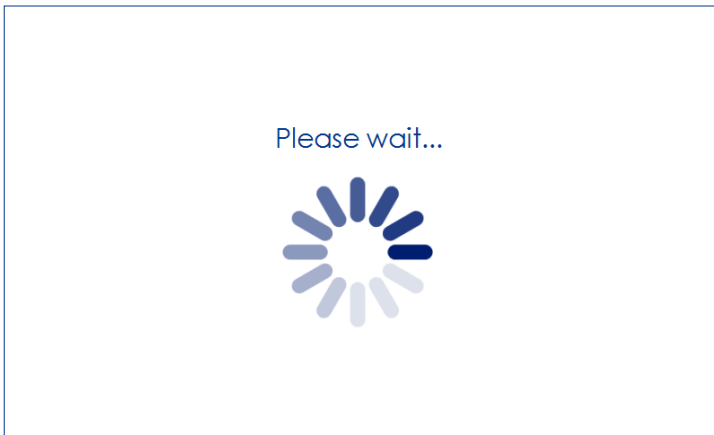

The Please wait screen

While the machine sometimes needs time to perform changes in settings, the Please wait screen will be shown.

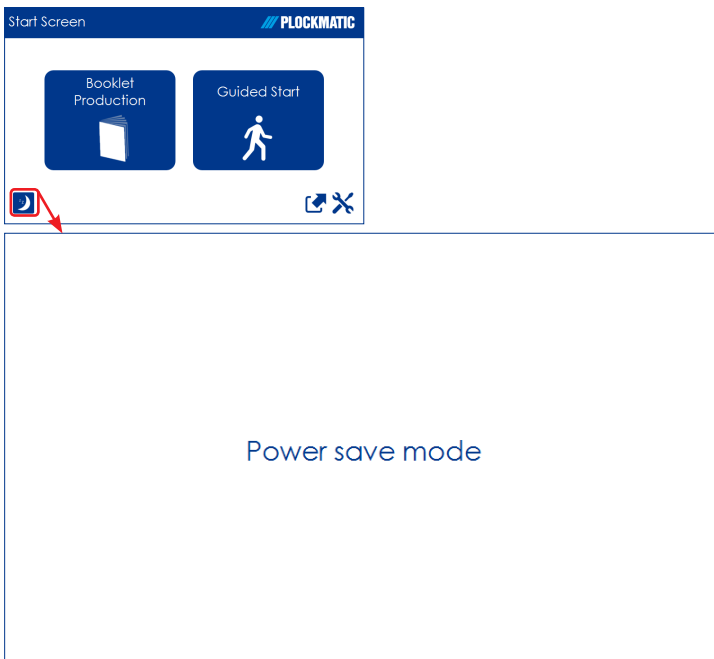

Power save mode

When the Booklet Maker System is in a ready state, it will enter power save mode after 20 minutes of inactivity.

To recover from Power save mode, touch the screen or send a print job to the Booklet Maker System.

The Booklet Maker System can also be forced into Power save mode by pressing the [Power save mode] button.

When the Booklet Maker system is processing or when there is a jam state it will not enter power save mode.

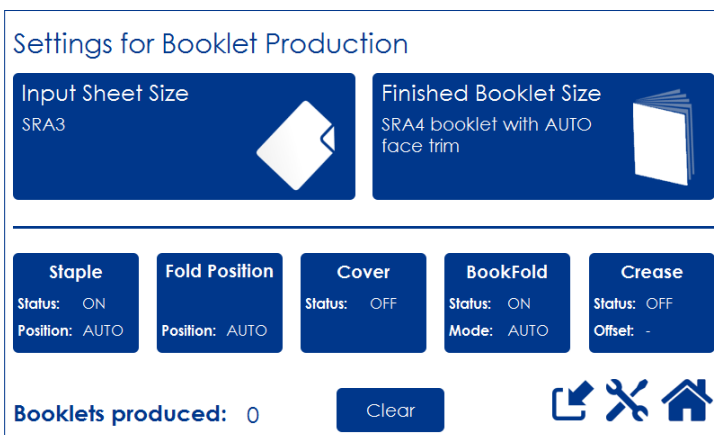

Information on screen

Depending on how the system is configured, the information on the screen changes and the size of the buttons will adapt to fit the screen.

This sample screen shows a fully configured Booklet Maker system with RCT, Cover Feeder, BookFold Module and Trimmer.

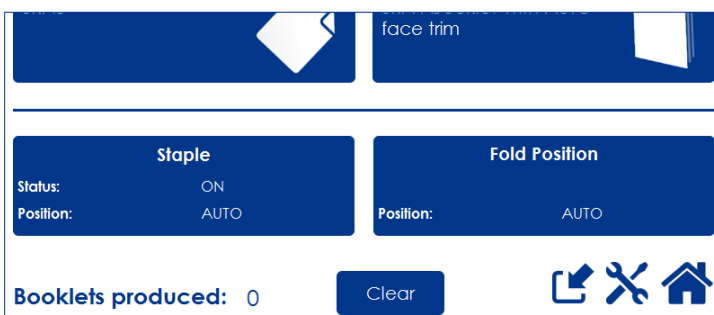

This sample screen shows exactly the same screen as above but this time the system is configured only with a Trimmer.

Options

Rotate Crease Trim Module

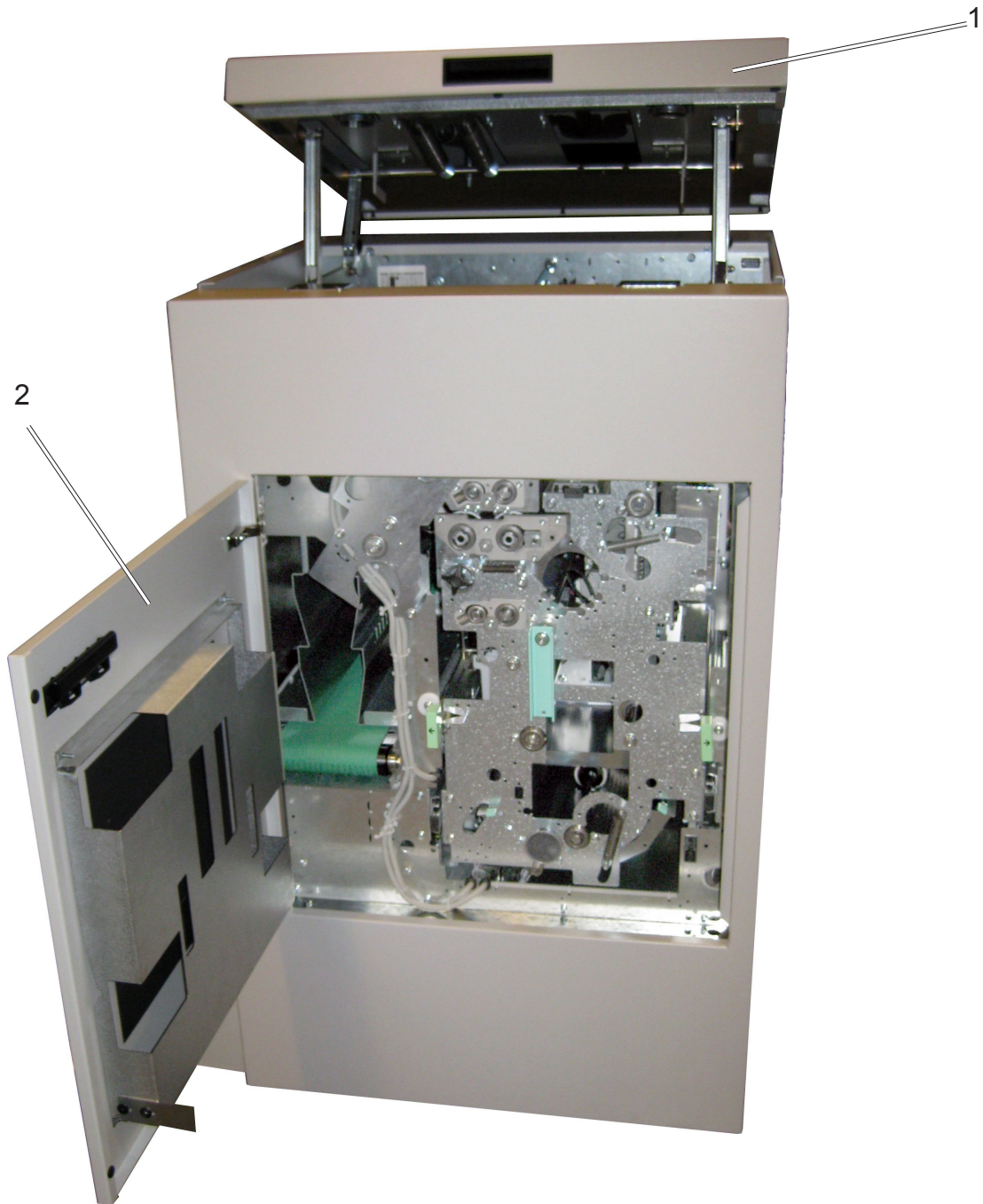

1. Top cover
2. Side door

Rotate Crease Trim Module, continued

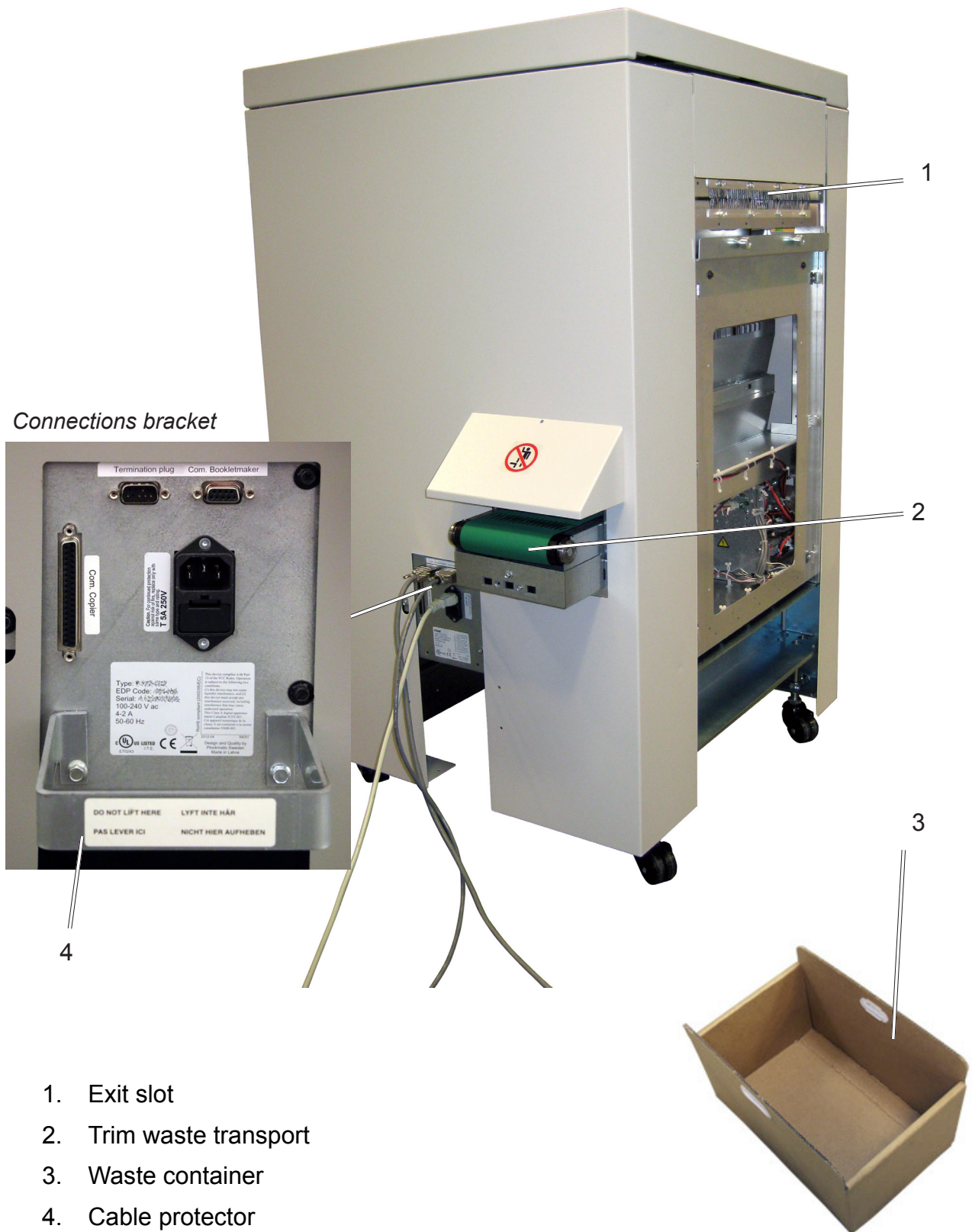

 **NOTE**

How to connect cables, plugs and jumpers is described at the end of this manual.

Rotate Crease Trim Module, continued

Parts that are important for setup, adjustments, troubleshooting or maintenance are highlighted below.

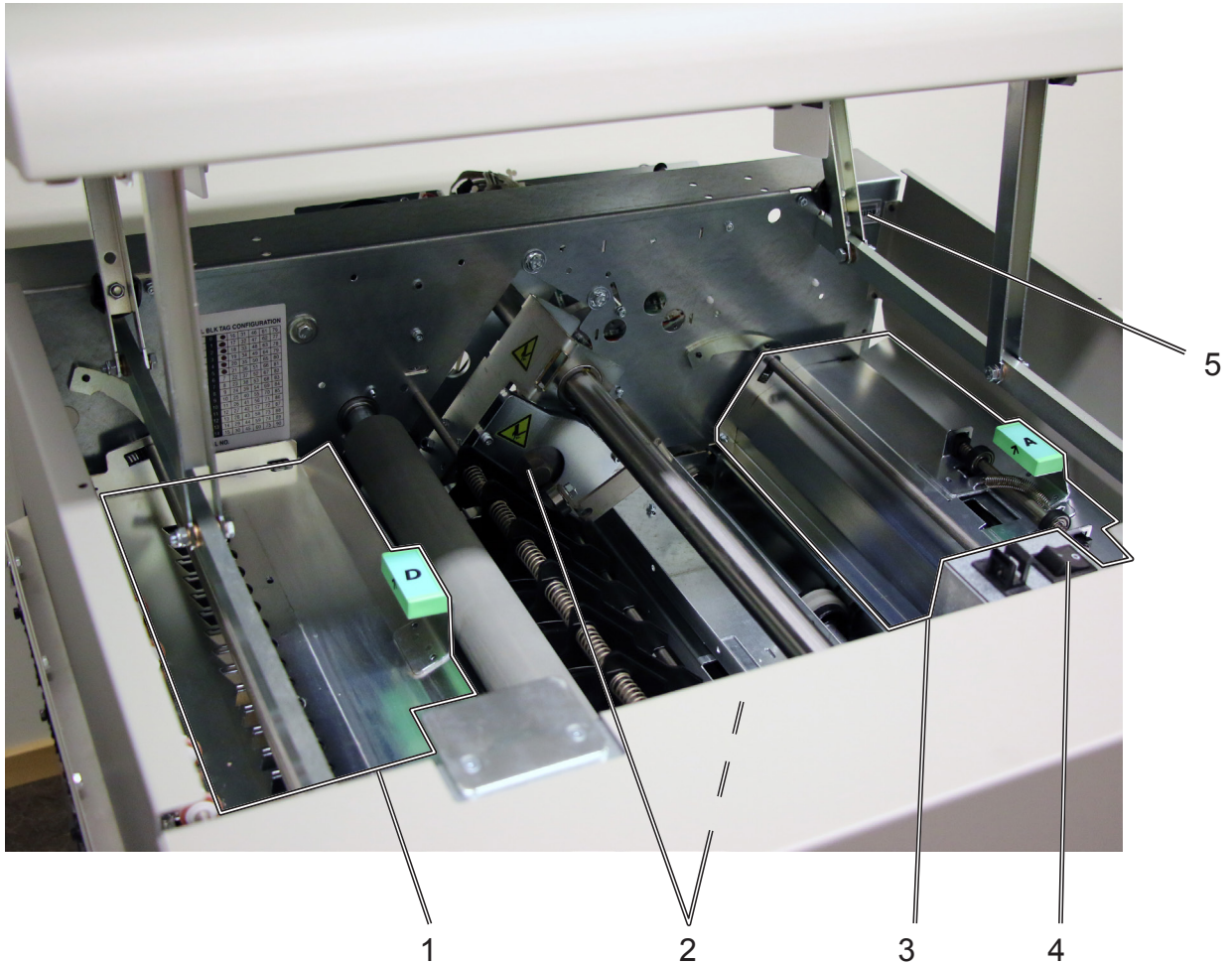

1. Exit section "D"
2. Bleed trimmer circular knives
3. Infeed Section "A"
4. Main switch
5. Counter

Rotate Crease Trim Module, continued

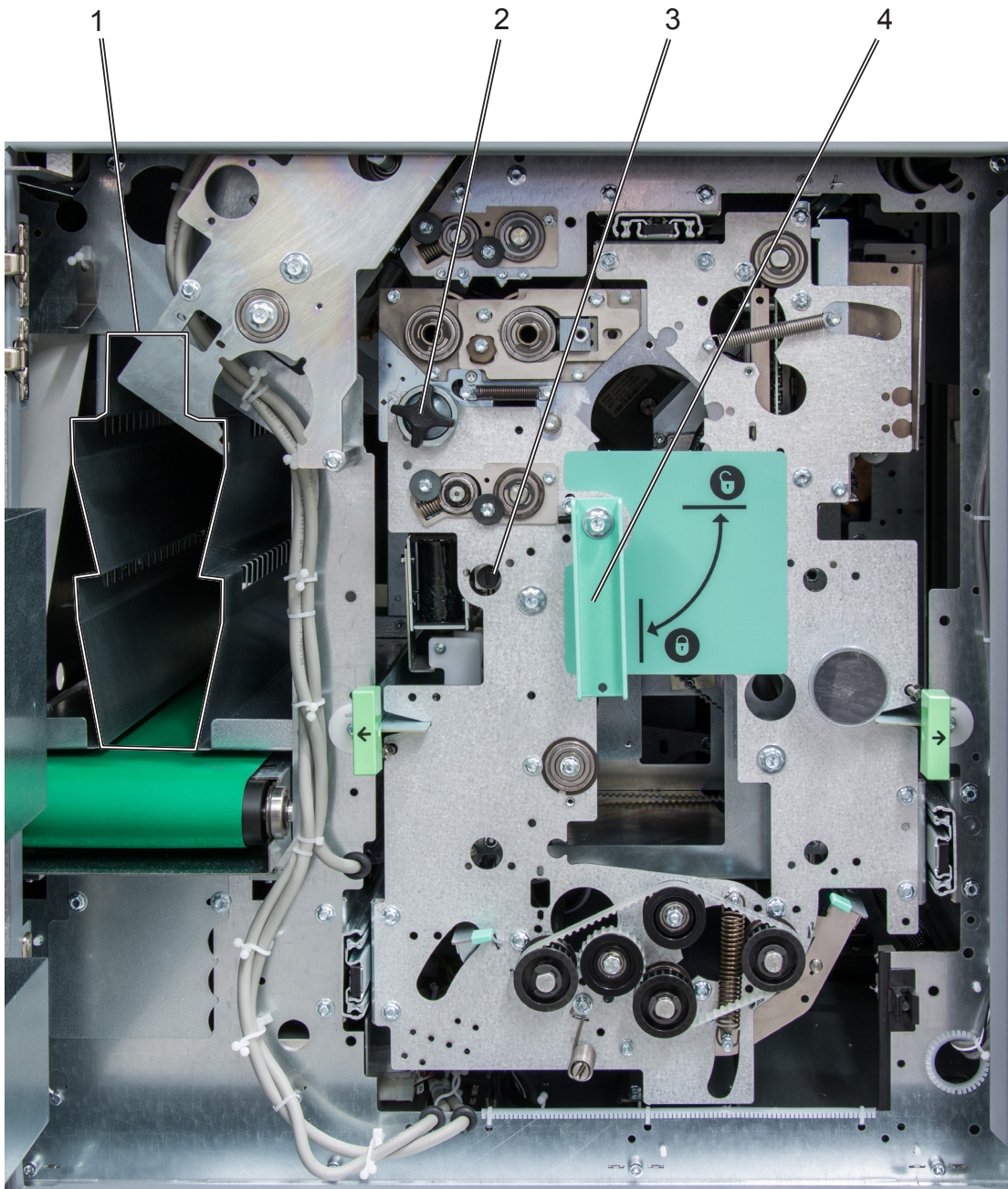

- 1 Waste chute(s)
- 2 Creaser registration adjustment
- 3 Bleed trimmer registration adjustment
- 4 Latch handle, slide

Rotate Crease Trim Module, continued

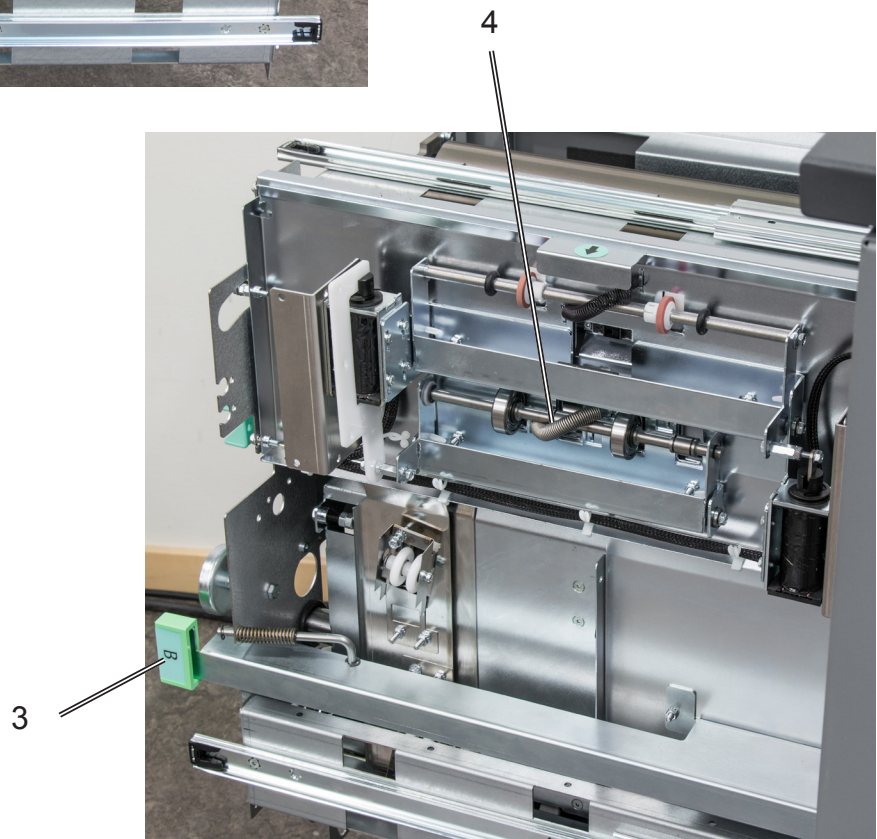
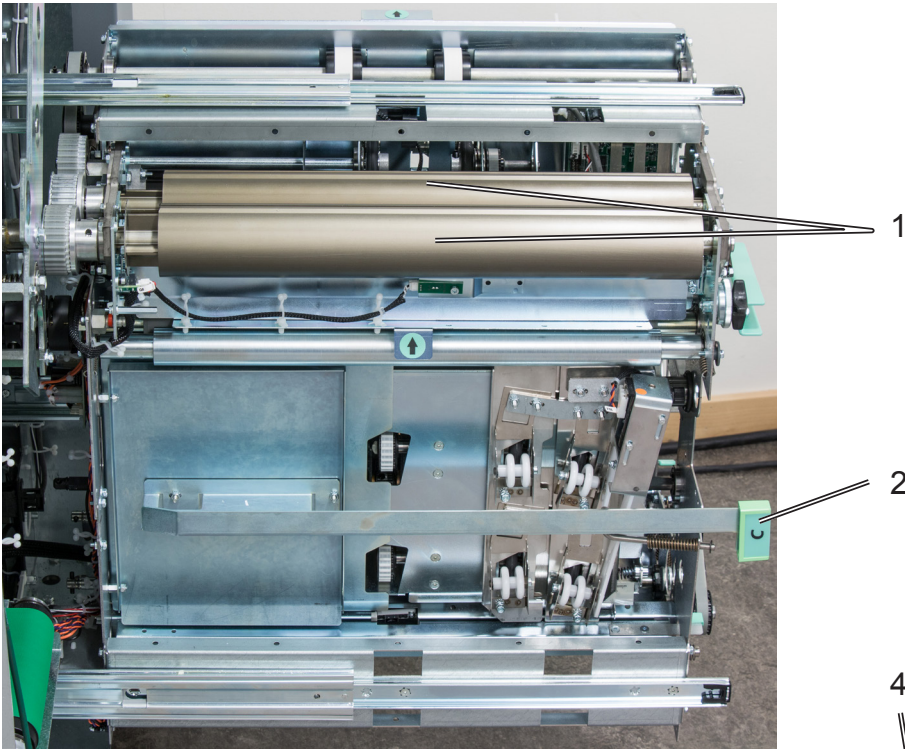

- 1 Creaser tools
- 2 Jam clearance baffle, fine registration, section "C"
- 3 Jam clearance baffle, coarse registration, section "B"
- 4 Rotator

Booklet Maker

Alive Logo



Alive Logo

With a BLM50 upgrade kit installed, the three stripes below the user interface will signal status as follows:

Not illuminated - System in power save mode or switched off.

Steady blue - System is on and ready.

Alternating blue/yellow - Soft stop (staples low, cover low, stacker full, waste bin full).

Alternating blue/red - Jam or malfunction

Cover Feeder

Parts that are important for setup, adjustments, troubleshooting or maintenance are highlighted below.

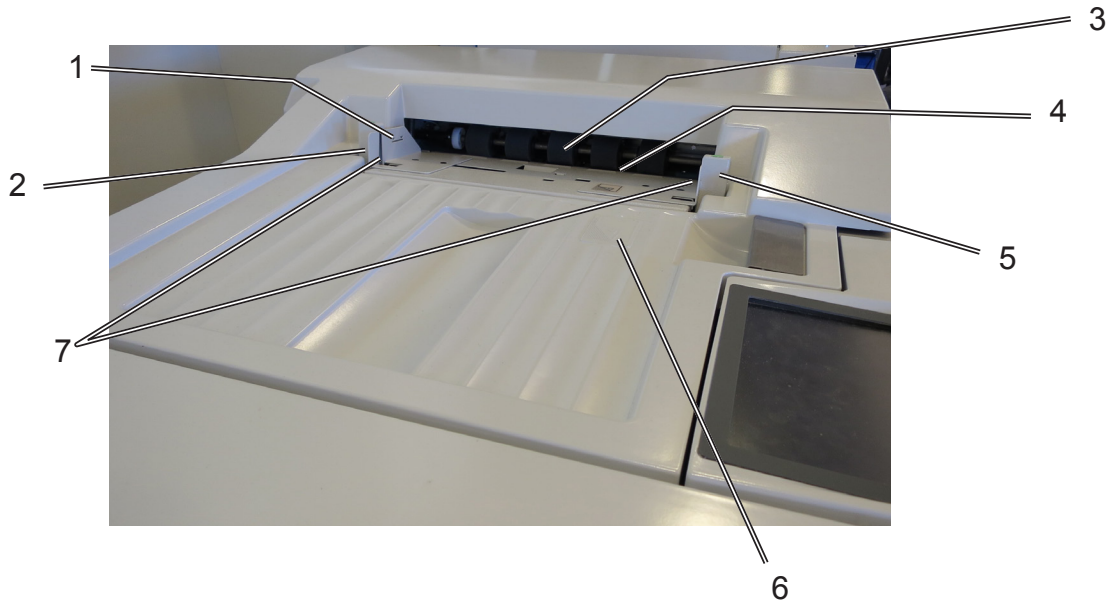

- | | | | |
|---|-----------------------|---|-----------------------------|
| 1 | Loading capacity mark | 5 | Front side guide |
| 2 | Rear side guide | 6 | Paper orientation indicator |
| 3 | Feed roller assembly | 7 | Air nozzle (2x) |
| 4 | Paper separator pad | 8 | Jam clearance baffle |

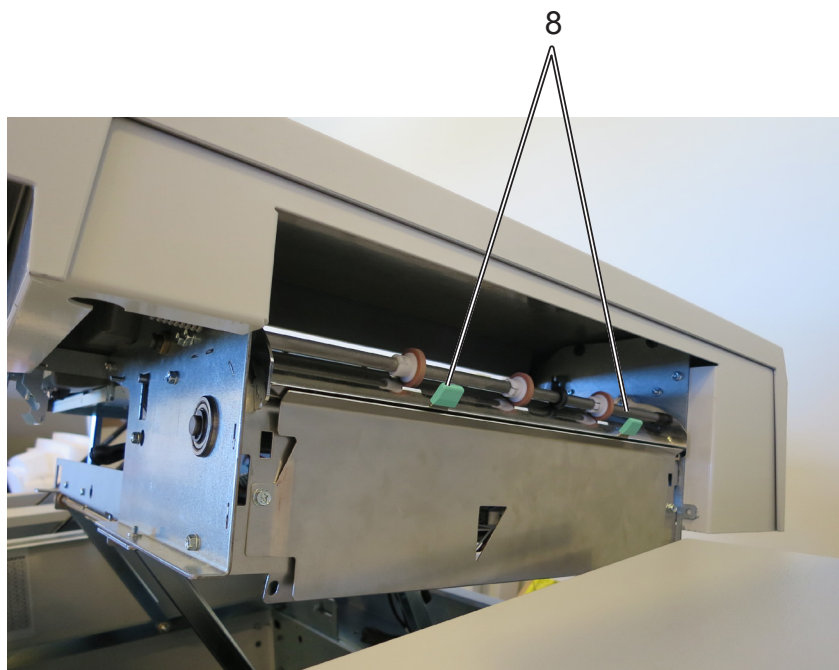

BookFold Module



 **NOTE:**

How to connect cables, plugs and jumpers is described at the end of this manual.

BookFold Module, continued

Parts that are important for setup, adjustments, troubleshooting or maintenance are highlighted below.

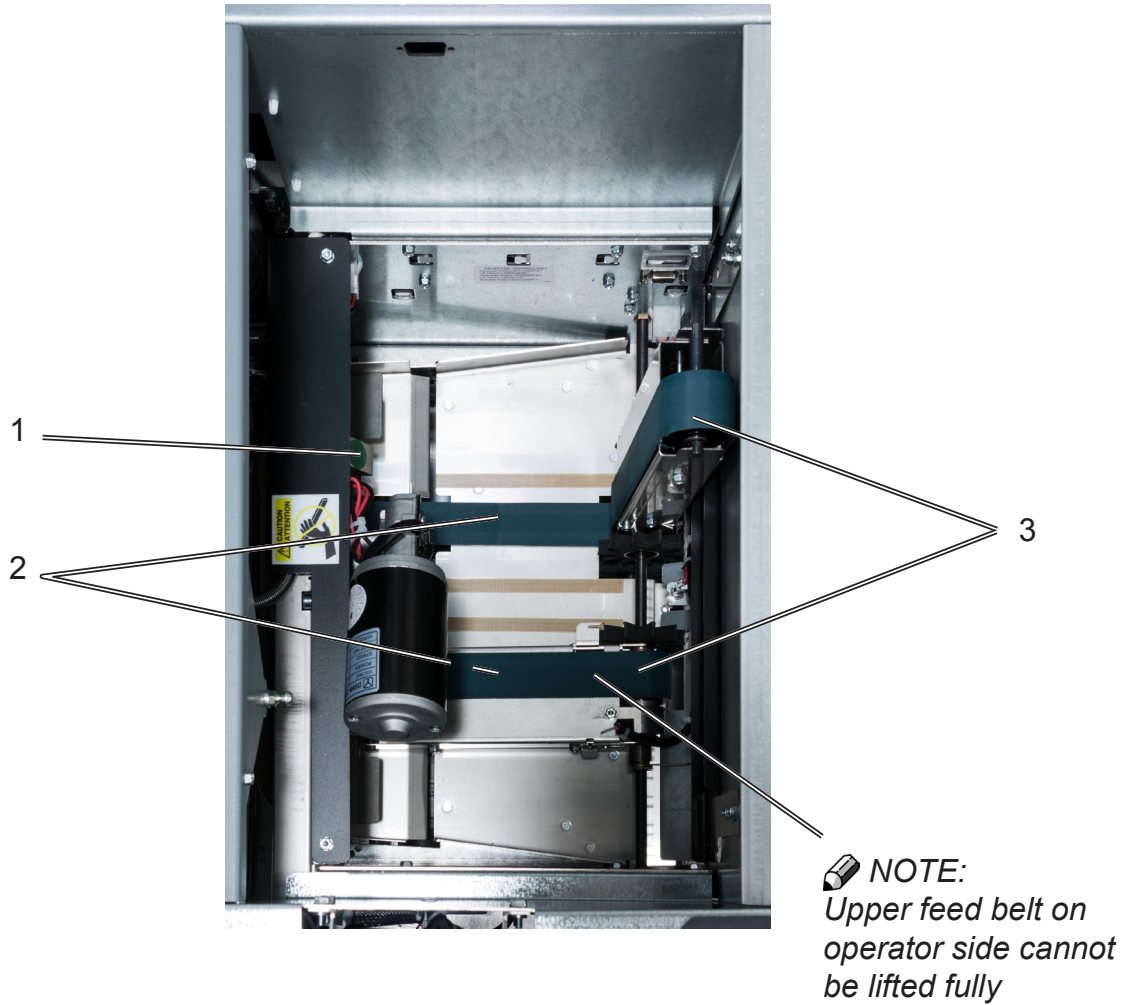

*BookFold Module, top view,
non operator side upper feed
belts lifted up*

- 1 Upper feed belt release latch
- 2 Lower feed belts
- 3 Upper feed belts

Trimmer



1. Top cover
2. Trim bin
3. Base
4. Connections
5. Cable protector

 **NOTE:**

How to connect cables, plugs and jumpers is described at the end of this manual.

Trimmer, continued

Parts that are important for setup, adjustments, troubleshooting or maintenance are highlighted below.

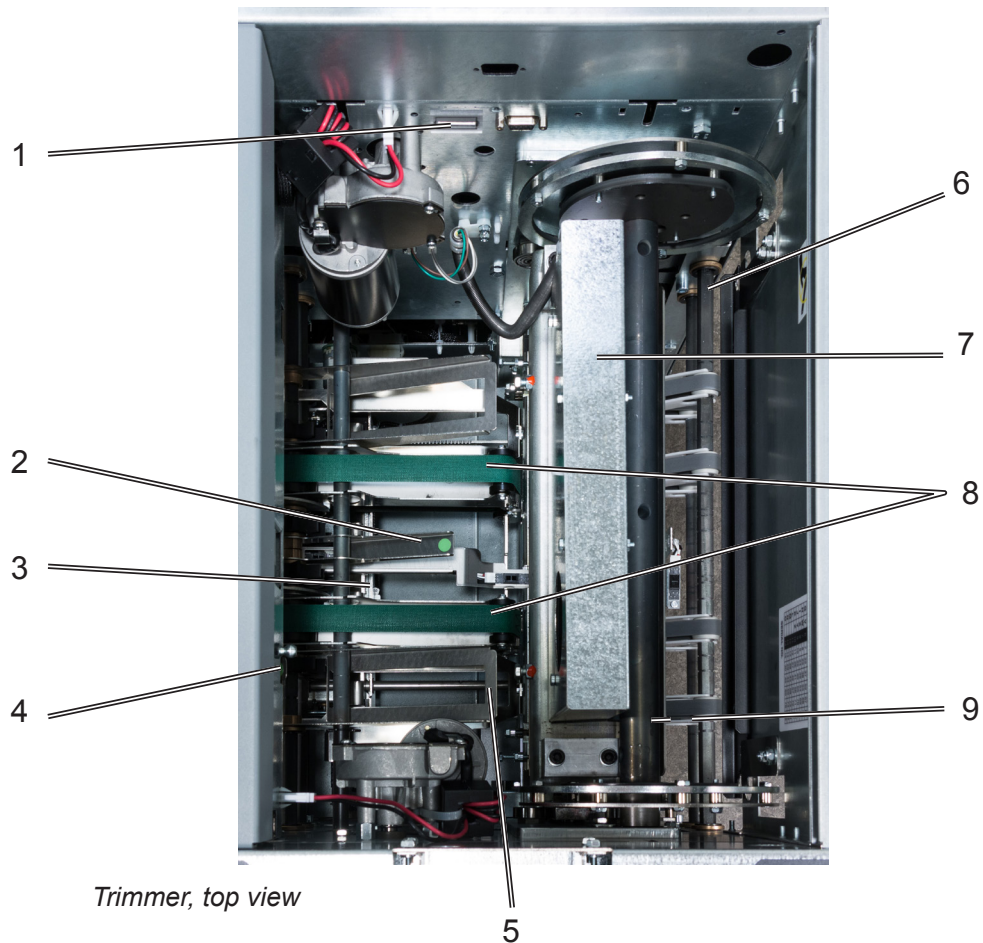

Trimmer, top view

- | | | | |
|---|---------------------------|---|---------------------|
| 1 | Set counter | 6 | Infeed roller shaft |
| 2 | Exit drive lifting lever | 7 | Trimmer fan |
| 3 | Trimmer stop | 8 | Transport belt |
| 4 | Exit drive release | 9 | Upper trim knife |
| 5 | Exit compressing brackets | | |

BST4000-1 Belt Stacker Module

The BST4000-1 High Capacity Belt Stacker Module is an option available for the Plockmatic BLM50 or BLM35 Production Booklet Maker System. The stacker can be configured in a straight line after the booklet maker system or at a 90 degree angle.

Parts that are important for setup, adjustments, troubleshooting or maintenance are highlighted below.

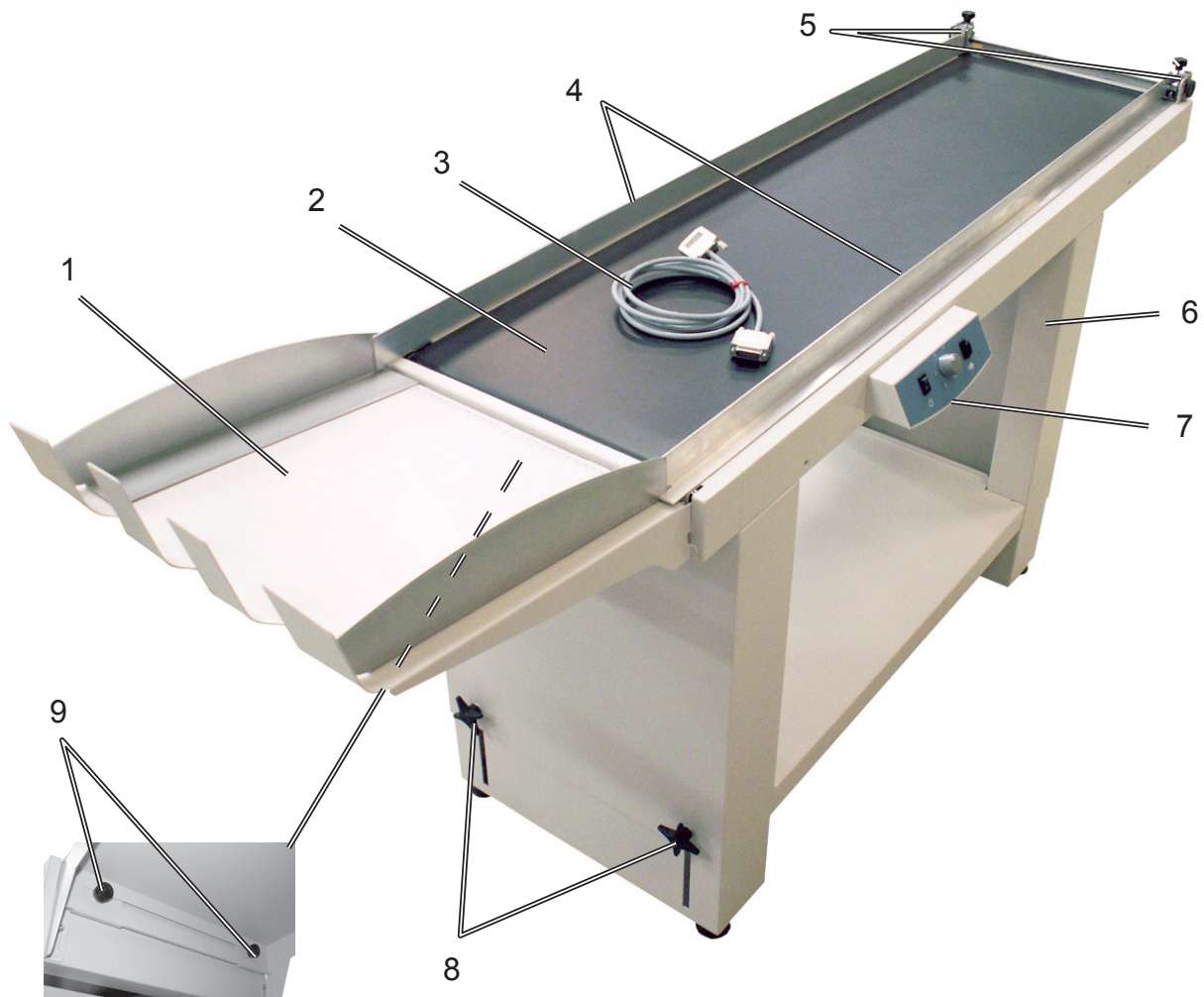

- 1 Stacking tray
- 2 Conveyor belt
- 3 COM-cable
- 4 Side guides
- 5 Front end side guide adjustment knobs
- 6 Leg assembly
- 7 Control panel box
- 8 Height adjustment knobs (two on each leg)
- 9 Rear end side guide adjustment knobs (underneath)

BST4000-1 Belt Stacker Module, continued

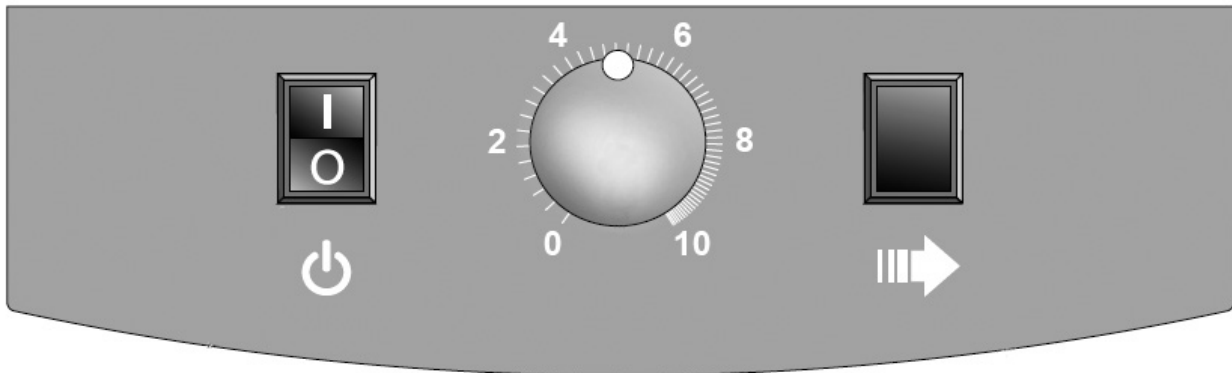

(1)

(2)

(3)

- 1 Power switch (on/off)
- 2 Belt speed selector
- 3 Run-out button (full speed)

BST4000-1 Principle of Operation

The belt is triggered by a signal from the Booklet Maker and will run for a set time.

The belt speed can be adjusted in order to optimize the stacking function for various materials.

The Run-out button is used to gather the material after a job is finished. The belt then moves at the highest speed, independent of the speed setting.

The power switch is also used to reset the unit after an overload situation.

Page intentionally blank.

1. Basics

Turning On / Off the Main Power

RCT, Booklet Maker, BookFold Module, Trimmer & BST Module

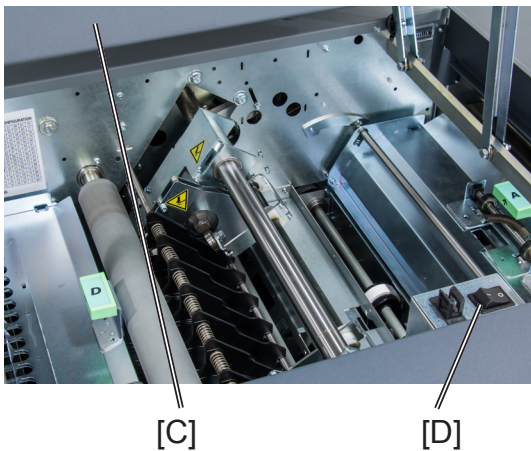
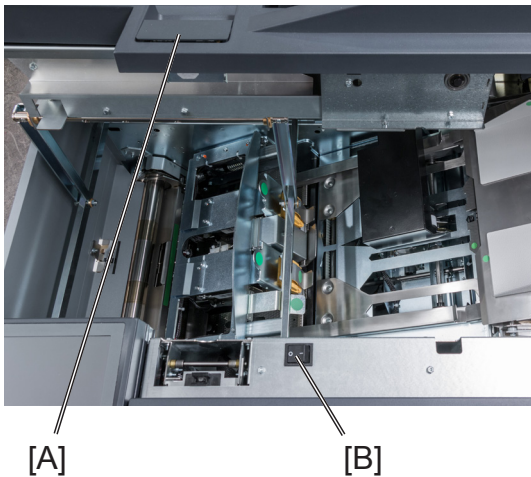

- 1 Make sure that the Booklet Maker, RCT module (optional) and BST power cords are plugged into the wall outlet.



NOTE:

BookFold (optional) and/or Trim (optional) Modules are both powered from the Booklet Maker.

- 2 Open the Booklet Maker top cover [A].
- 3 Set main power switch [B] on Booklet Maker to ON position. If a BookFold Module and Trimmer are attached, they will be powered on via the Booklet Maker main power switch.
- 4 Close the Booklet Maker top cover.
- 5 Open the top cover of the RCT [C].
- 6 Set the main power switch [D] to ON position.
- 7 Close the RCT top cover.

- 8 Set main power switch [E] on the BST Module to ON position.

Change staple cartridges and Check Stapler

The staple cartridges contains approximately 5000 staples each. Each cartridge includes all wearable parts. The cartridges may need to be removed either for replacement or for jam clearance.

1

Change left/right staple cartridge(s)

Attention!

Area B2: Replace right and left staple cartridges!

Turn staple off

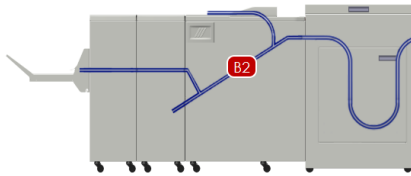

The Booklet Maker will indicate “Replace left/right/left and right staple cartridges” when there are approximately 20 staples left in the stapler cartridge. Replace the indicated staple cartridge by doing the following:

- 1 Open the Booklet Maker top cover.
- 2 Remove one or both staple cartridges by lifting the lever [A], pressing either or both levers [B] and pulling either or both staple cartridges [C] out using the grip [E] at both sides of the staple cartridge.

 NOTE:

Lever [A] controls the stapler guides [D]. It is kept in place by a magnet and can be hard to release. Pressing either lever [B] makes it a bit easier to overcome the force of the magnet.

- 3 Replace by pushing a new staple cartridge into stapler until it snaps into position.
- 4 Put the stapler guides [D] back in position so that lever is locked by the magnet.
- 5 Close booklet maker top cover and restart the job.

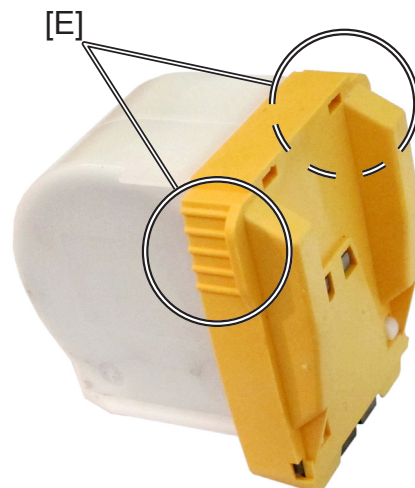
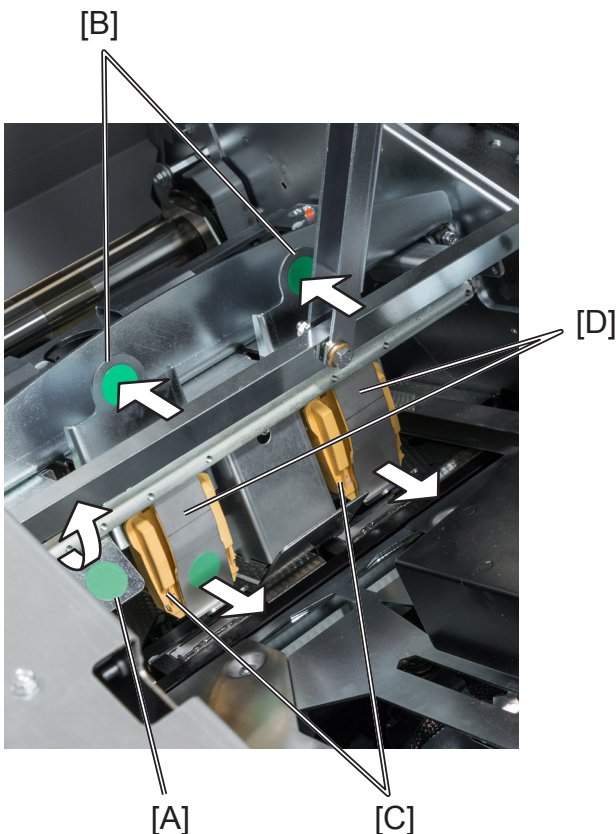

Check left/right stapler

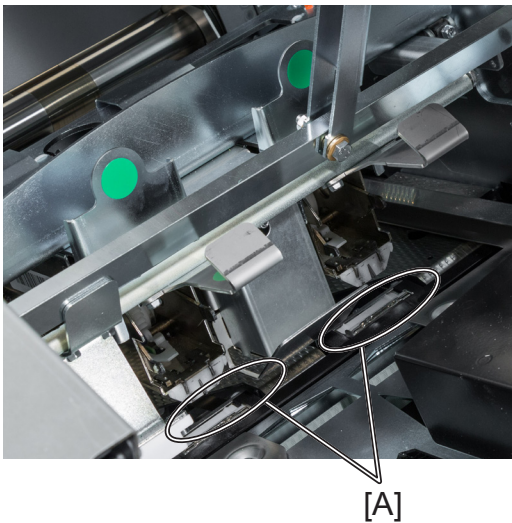
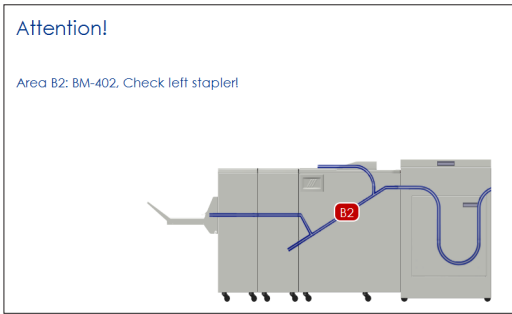

If the Booklet Maker indicates “Check right/left/right and left stapler”, it means that there is a jam in the indicated stapler. Remove the stapler cartridge as described above.

- 1 Open the Booklet Maker top cover.
- 2 Remove either or both staple cartridge(s) as described above.
- 3 Remove any sheets left in the Booklet Maker and look for jammed staples stuck in the sheets.
- 4 Look inside the staple cartridge for jammed staples and remove them if any.
- 5 Look at the clinchers [A] and remove any jammed staples.
- 6 Push the staple cartridge(s) into stapler until it snaps into position and lock stapler guides in position as described above.
- 7 Close Booklet Maker top cover and restart job.

 **NOTE:**

If the error message persists for no reason or if staple jam reoccurs, replace the staple cartridge as described above.

Cover Feeder

Loading covers

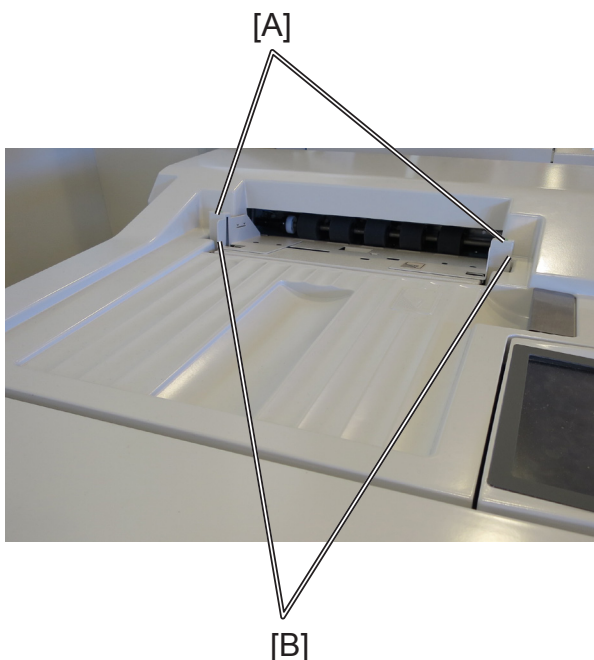

- 1 Make sure the cover sheets are well fanned to avoid misfeeds or double-feeds.
- 2 Align the cover sheets well to achieve a reliable feeding operation and good finishing results.
- 3 Make sure that the ink has completely dried, to avoid smearing.
- 4 Press on top of either air nozzle [A] to lower the paper bin. Load the covers facing downwards into the paper bin.
- 5 Adjust side guides [B] up against the cover sheets until there is no clearance.

 **NOTE:**

Make sure covers are same size as sheets fed to booklet maker. When using an RCT, see Note under “Changing settings, Finished Booklet Size, Custom booklet size”.

Emptying the trim waste bin

Remove the trim waste bin by lifting it and pulling it out.

1

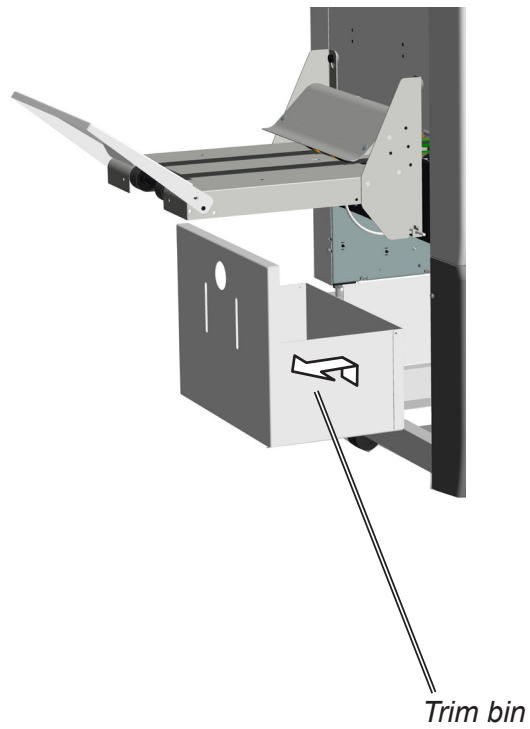

Belt Stacker

Setting up Belt Stacker for right-angled mode

Follow these steps to correctly set up the Stacker

1

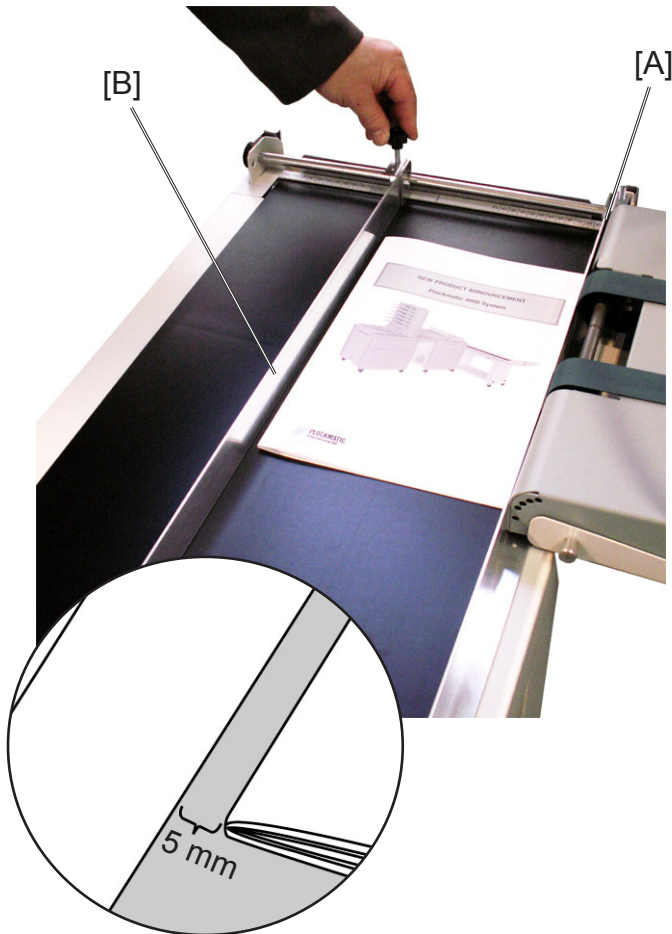

- 1** Move the inner Side Guide [A] as far as possible towards the Booklet Maker.
- 2** Adjust the outer Side Guide [B] to give at least 5mm (1/4") play. Tighten the Side Guides at both ends.
- 3** Adjust the stacking with belt speed selector.

Setting up Belt Stacker for straight mode

1

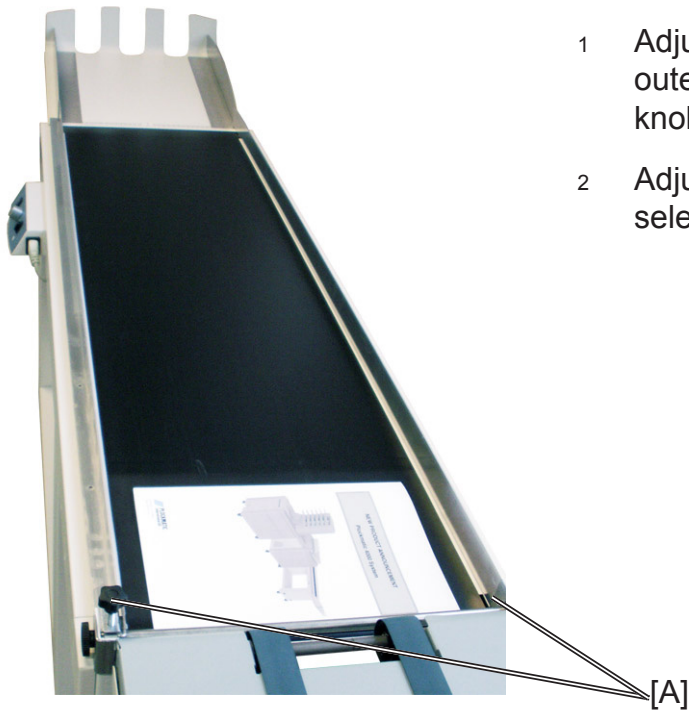

- 1 Adjust Side Guides to their outermost position by loosening knobs [A].
- 2 Adjust the stacking with belt speed selector [B].

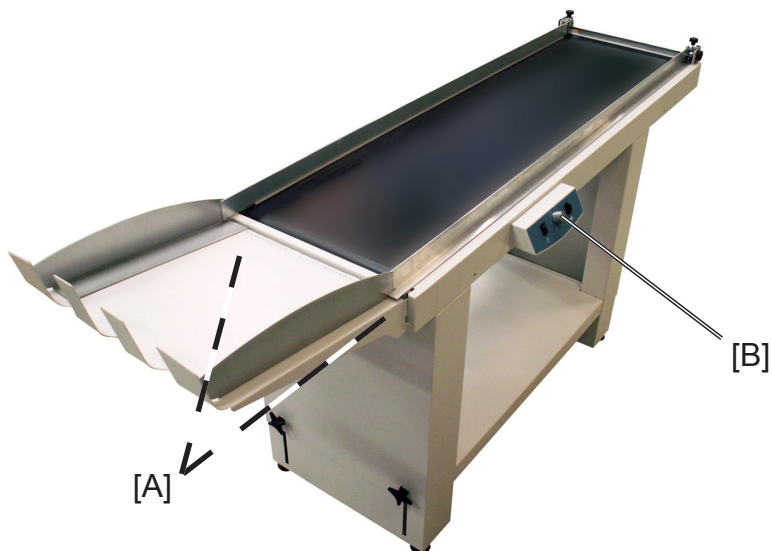

2. Making Booklets

Guided Start

Guided Start is a function that takes you through all the basic settings the Booklet Maker System needs to start booklet production in a few easy steps. Customizing settings and fine adjustments are described later in this chapter.

Guided Start, step by step

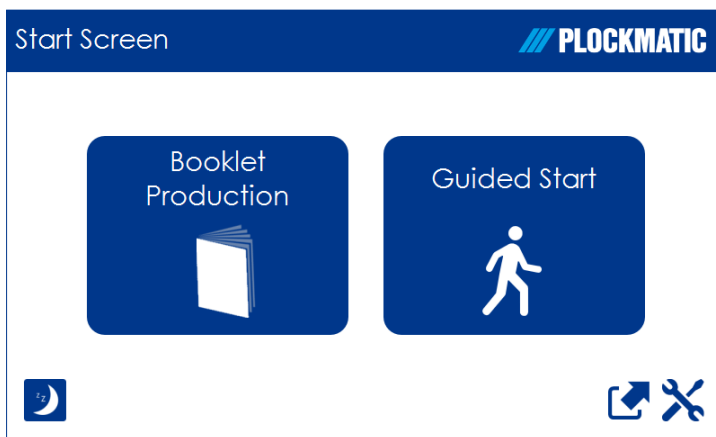

Guided Start

Press the [Guided Start] button to enter the Guided Start procedure.

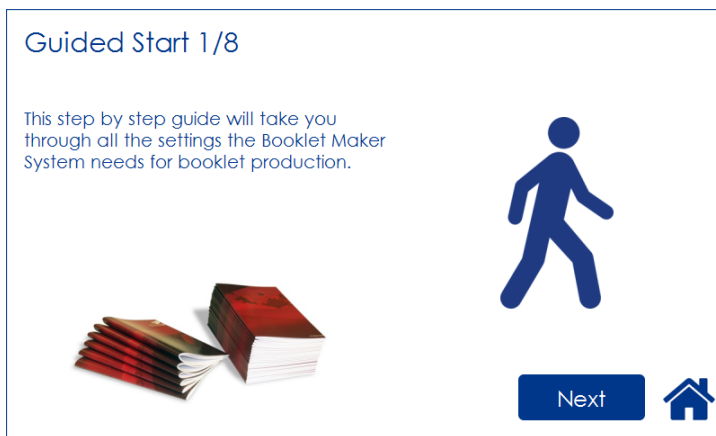

Guided Start 1/8

This is the first of up to 8 screens. Depending on how the system is configured and your selections during this procedure, the number of screens may be less than 8.

Configuration of the system also affects the information shown and button size will adapt to fit screen.

To proceed from one screen to another, press the [Next] button.

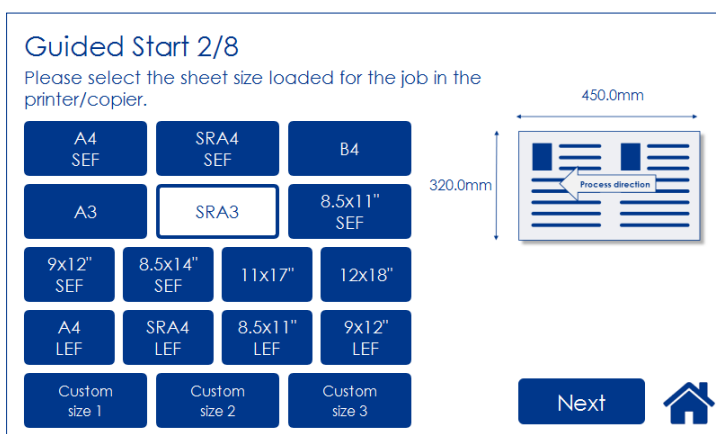

Guided Start 2/8

Select the sheet size loaded for the job by pressing the corresponding button.

For other sizes, follow "Custom sheet size" described in section "Basic Settings" below.

Guided Start 3/8

Please select the size of the finished Booklet

A4 booklet

SRA4 booklet with
AUTO face trim

Custom Booklet Size
225.0 x 320.0mm

Edit

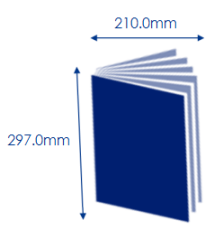

Back

Next

🏠

Guided Start 3/8

Choose either of two suggested formats (except for B4 which only has one suggested format).

When Face Trim is set to Auto, a minimum trim, based on the information from Set Thickness Sensor, is calculated.

To set the trim manually, follow “Finished Booklet size” described in section “Basic Settings” below.

Guided Start 4/8

Will a cover be added from the Plockmatic Cover Feeder?

Yes

No



Back

Next

🏠

Guided Start 4/8

Select whether the Cover Feeder is to be used or not and press the corresponding button.

Guided Start 5/8

Load covers in the Plockmatic Cover Feeder.

After loading the covers, press Next.



i Info: The side of the cover page that will be the outside cover of the book shall face downwards

Back

Next

🏠

Guided Start 5/8

Load the covers face down.

NOTE:

Make sure covers are same size as sheets fed to the Booklet Maker.

When using the bleed trim function and feeding covers at the same time, make sure covers loaded in Cover Feeder are same size as sheets fed from RCT to the Booklet Maker.

Guided Start 6/8

Shall the booklet be finished with a square spine?

Yes

No



i Info: For thin sets this feature will be automatically switched off.

Back

Next

🏠

Guided Start 6/8

Select whether or not the booklet should have a square formed spine and press the corresponding button.

NOTE:

If the job includes a small number of lighter weight sheets, the square forming action will be switched off and the BookFold Module will be bypassed.

Guided Start 7/8

Shall the booklet be finished with a creased cover?

Yes

No



i Info: This feature is used to avoid image cracking on the spine of thin books (less than 6 sheets).

Back
Finish

Guided Start 7/8

Select whether the booklets should have a creased cover or not. This feature is used to avoid high area coverage toner cracking on the spine on booklets containing less than 6 sheets.

Press the corresponding button.

After you are done, press the [Finish] button to conclude the Guided Start.

Guided Start 8/8

Your Booklet Maker System is now ready for production.

Please start the production by sending the print job from the printer.

i Info: Check the appearance of the finished book and adjust any settings that might require adjusting from the "Settings for Booklet Production" page.



Guided Start 8/8

All settings needed to begin producing booklets are now set.

Start production by sending the print job from the printer.

Settings for Booklet Production

Input Sheet Size
SRA3



Finished Booklet Size
Custom size
210.0 x 297.0mm



Staple
Status: ON
Position: AUTO



Fold Position
Position: AUTO

Cover
Status: ON

BookFold
Status: ON
Mode: AUTO

Crease
Status: Fine
Offset: 0.0mm

Booklets produced: 0

Clear



After the job has been sent to the Booklet Maker System, the "Settings for Booklet Production" screen is shown.

From here you can customize and fine-tune settings, save the job and access the Tools screen.

Customizing and fine-tuning settings is described below in this section.

How to save jobs is described in section 4, "Jobs."

Tools are described in section 3, "Tools."

Press Home to return to the "Start Screen".

Changing settings

General procedure

Settings can be changed in one of two ways. “Temporary”, which means that the changes will remain until a new job is loaded or “Permanent”, which means that the changes will be stored as a job. This job can later be recalled.

Procedure for temporary changes:

From the Settings for Booklet Production screen, select the option you wish to alter and make your selection. Confirm by pressing the green [check] button. You will be returned to the Settings for Booklet Production screen

Procedure for permanent changes:



To keep your new settings, press the [Save current settings] button. Follow on screen instructions to save your current settings as a new job or to an existing job.

NOTE:

Choose either of the above mentioned procedures when changing size, stapling, trimming, covers or square forming as follows.

Depending on how the system is configured, the number of settings that can be selected varies. The information on the screen and the size of the buttons will adapt to fit the screen. Examples below show a fully configured system.

Basic settings

Input Sheet Size

Selecting standard paper sizes

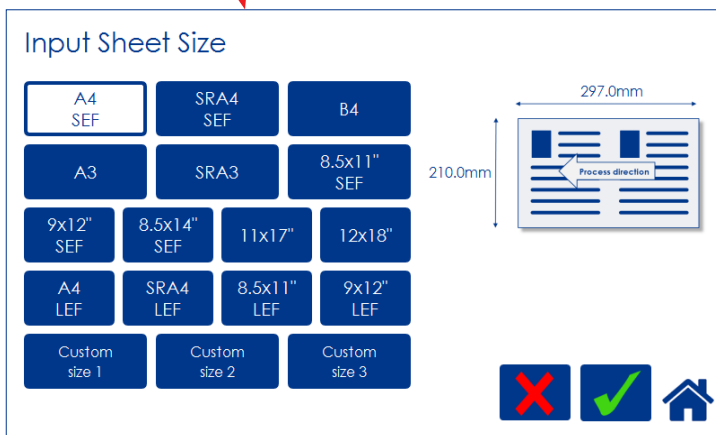
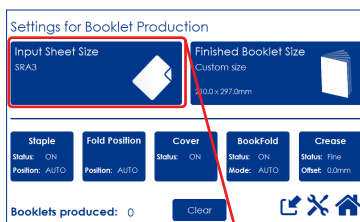

From the Settings for Booklet Production screen, press the [Input Sheet Size] button.

Select any standard paper size by pressing the corresponding button and save choice by pressing the green [check] button.

Depending on configuration, available standard paper sizes may differ. The LEF paper sizes are only available if there is a RCT installed.

For other paper sizes, follow “Custom input sheet size” as described on the next page.

NOTE:

Change of paper size will set Staple position, Fold position, BookFold and Crease to Auto and Cover to Off.

Any Fine-tuning (see section below) and the “Booklets produced” counter will also be reset.

AUTO sheet size

AUTO means that the Booklet Maker will adjust to the paper size information sent from the printer. Auto Rotate will be turned on and a finished booklet size will be chosen from a predefined list i.e. the [Finished Booklet Size] button will be greyed out. No other settings will be affected.

Custom input sheet size

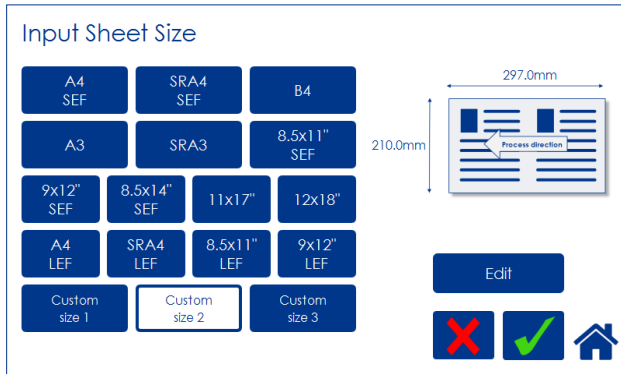

From the Input sheet size screen, press any of the Custom size buttons and then press the [Edit] button.

NOTE:
Changing to a Custom input sheet size will NOT change Staple position, Fold position, Cover, BookFold, Crease or Fine adjustment settings. The “Booklets produced” counter will still be reset.

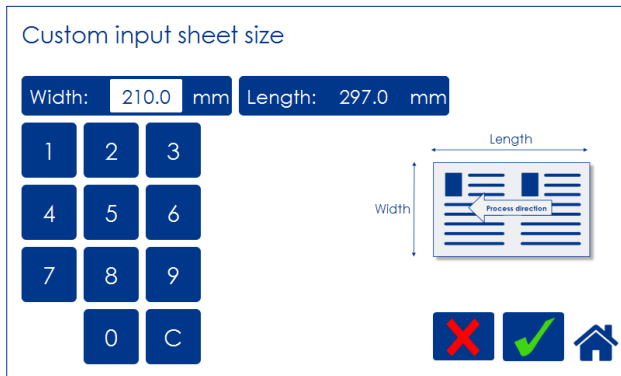

Select Length and/or Width and key in the desired value. Save the custom size format by pressing the [check] button.

Three different custom paper sizes can be stored.

NOTE:
A full number (incl. decimal point and fractions of an inch/mm) must be entered before the green [check] button appears.

Save setting by pressing the green [check] button.

Finished Booklet Size

Auto trimming

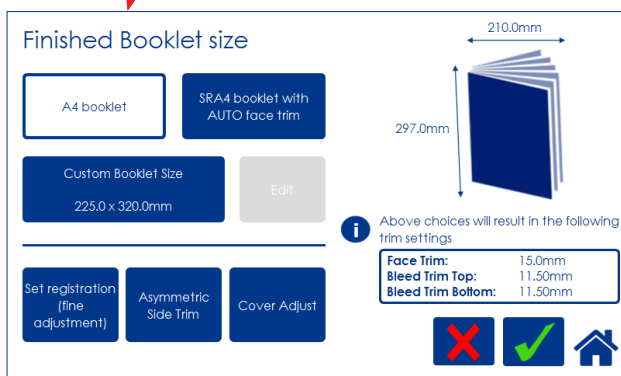
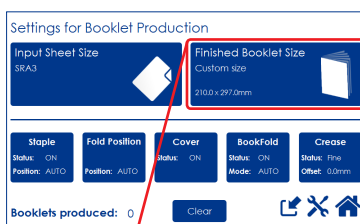

From the Settings for Booklet Production screen, press [Finished Booklet Size]. Trimming can now be set to either of two suggested formats (except for B4 which only has one suggested format) or Custom Booklet Size.

When Face Trim is set to Auto, a minimum trim, based on the information from Set Thickness Sensor, is calculated.

For custom sized booklets, see below.

Custom booklet size

2

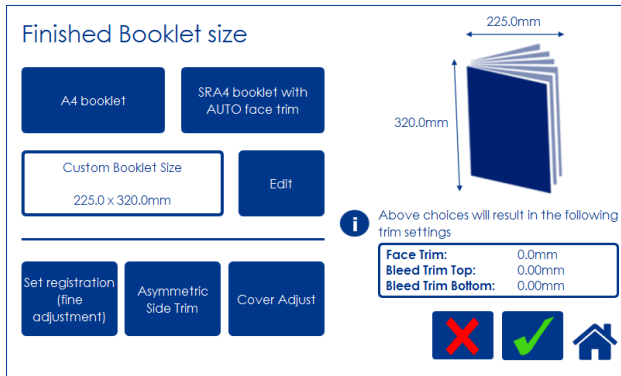

To set the trim manually, press [Custom Booklet Size] and then [Edit].

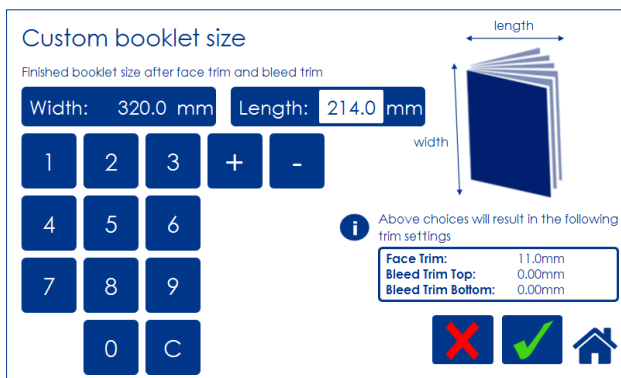

To adjust the amount of face trim, press the number on the [Length] button and type in the desired length of the booklet, decimals included. Also, the [plus] and [minus] buttons can be used to change the numbers. The amount of face trim is displayed in the box.

Press the green [check] button to confirm or continue adjusting the amount of bleed trim.

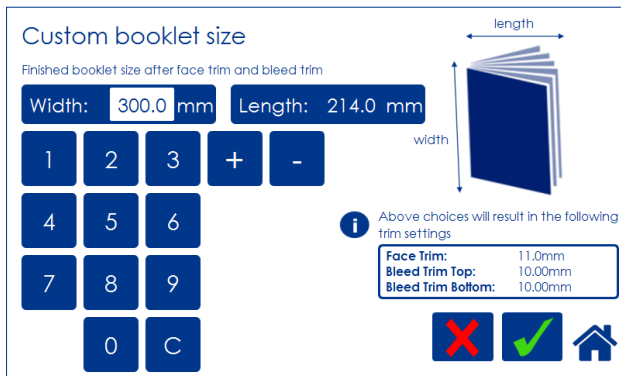

To also adjust the amount of bleed trim, press the number on the [Width] button and type in the desired width of the booklet, decimals included. Also the [plus] and [minus] buttons can be used to change the numbers. The amount of bleed trim is displayed in the box.

Press the green [check] button to confirm.

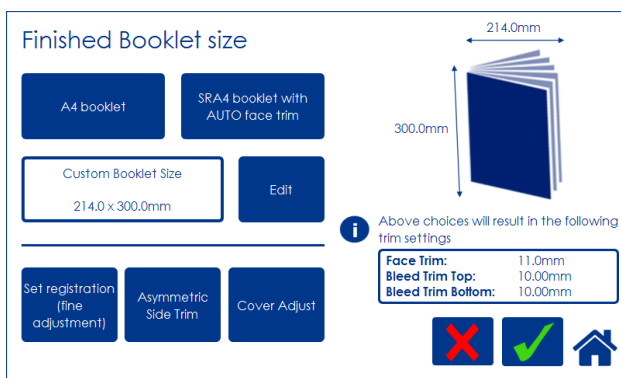

Back in the Finished Booklet size screen, the size of the finished booklet and the amount of face and bleed trim is displayed.

Press the green [check] button to confirm.

NOTE:

When using the bleed trim function and feeding covers at the same time, make sure covers loaded in Cover Feeder are the same size as sheets fed from the RCT. According to the example on the left, covers must be 300x450mm.

Customizing settings

Staple

Selecting stapling On or Off

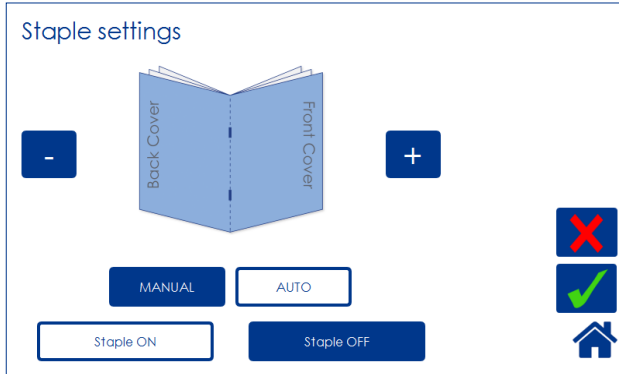

From the Settings for Booklet Production screen, press the [Staple] button.

2

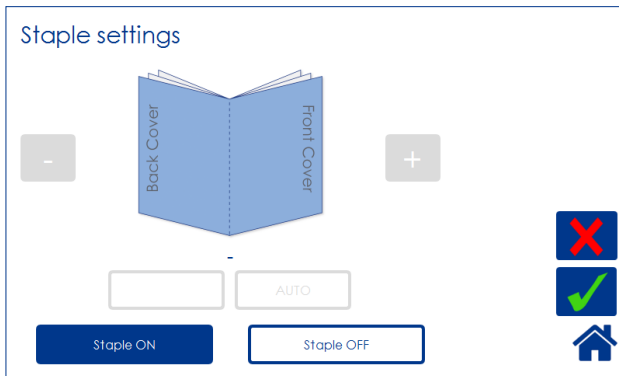

Select On or Off by pressing the corresponding button and save setting by pressing the green [check] button.

Adjusting staple position

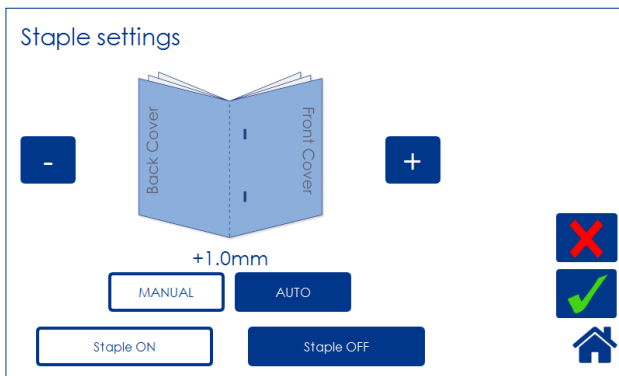

From the Settings for Booklet Production screen, press the [Staple] button.

Set to Manual, the staple position can be altered up to 3 mm (0.12") on either side of the fold. Press the [+] button move position closer to the lead edge and press the [-] button move position closer to the trail edge. Save setting by pressing the green [check] button.

NOTE:

This change can be performed during run.

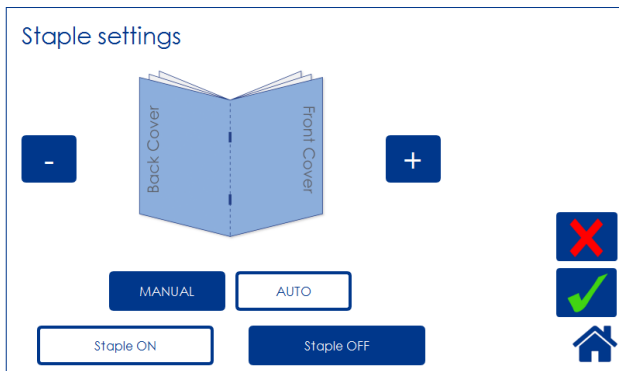

Set to Auto, the Booklet Maker uses the set thickness sensor to adjust the staple position. Press the [Auto] button and save setting by pressing the green [check] button.

Fold position

Adjusting fold position

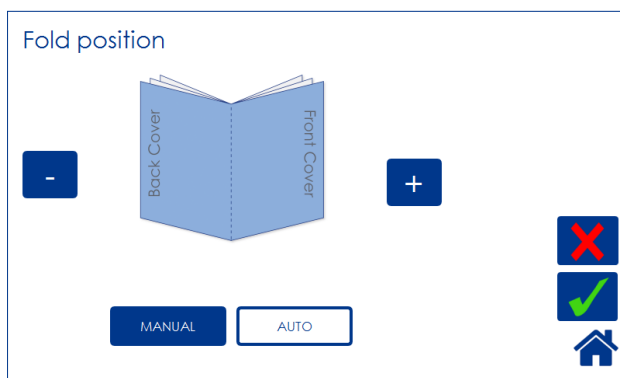
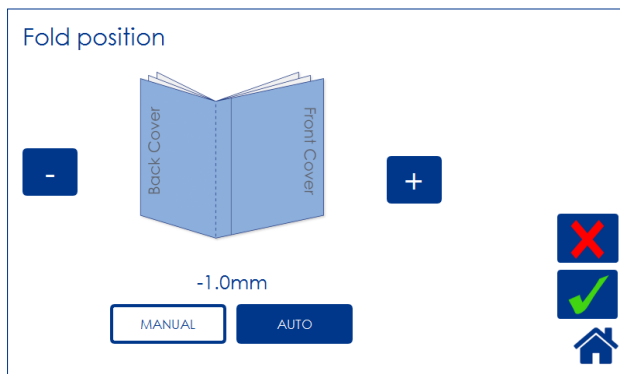

From the Settings for Booklet Production screen, press the [Fold position] button.

The position of the fold can be changed up to 3 mm (0.12") on either side of the center of the set. Press the [+] button move position closer to the lead edge and press the [-] button move position closer to the trail edge. Save setting by pressing the green [check] button.

NOTE:

This change can be performed during run. You may want to turn off trimming to see the result more clearly when you move the fold position.

Set to Auto, the Booklet Maker uses the set thickness sensor to adjust the fold position. Press the [Auto] button and save setting by pressing the green [check] button.

Cover

General

If the optional Cover Feeder is installed, the [Cover] button will be visible in the control panel. If enabled, the cover feeder will automatically feed one sheet to each set from the printer, or one sheet to each manually, hand-fed set.

A higher paper weight, pre-printed cover is fed to the set waiting in the compiler. The set and the cover are then stapled and folded together.

Depending of system configuration, the booklet is then fed to the Belt Stacker, BookFold Module or Trimmer.

NOTE:

Make sure sheets fed from Cover Feeder are the same size as sheets fed to booklet maker from printer or by hand. When using an RCT, see Note under "Changing settings, Finished Booklet Size, Custom booklet size".

NOTE:

After selecting Cover [Yes], when the green [check] button is pressed, the Cover Feeder will try to move the first sheet into feeding position. Therefore, load covers before pressing the green [check] button to avoid the error message "Load covers" from being shown. See section 1, "Basics" for how to load covers.

The Cover Feeder can also be used as a regular feeder. See section 3, "Tools".

NOTE:

In case of a cover feeding jam/error, it is difficult to remove a stuck cover due to the very strong separation nip. Removing the stack of sheets and then using the purge button on the stuck sheet is the easiest way to remove a cover that is stuck.

Cover

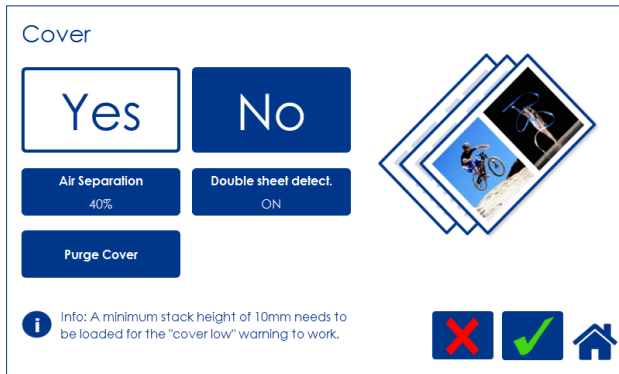

From the Settings for Booklet Production screen, press the [Cover] button. Press the [Yes] button and confirm by pressing the green [check] button.

Air Separation

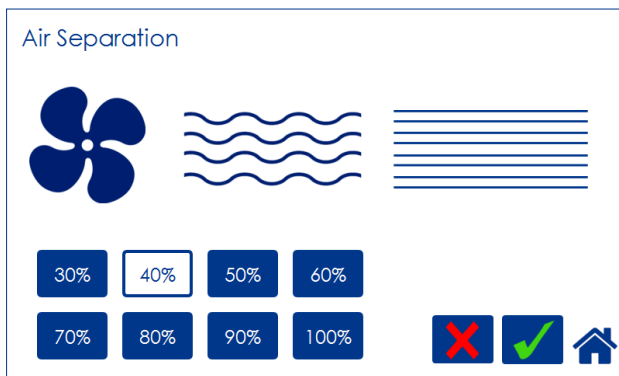

You may want to increase the Air flow when running thick, heavy covers. From the Cover screen, press the [Air separation] button. Set the desired amount of air flow by pressing the corresponding button and save setting by pressing the green [check] button. Default setting is 40%.

Double Sheet Detection

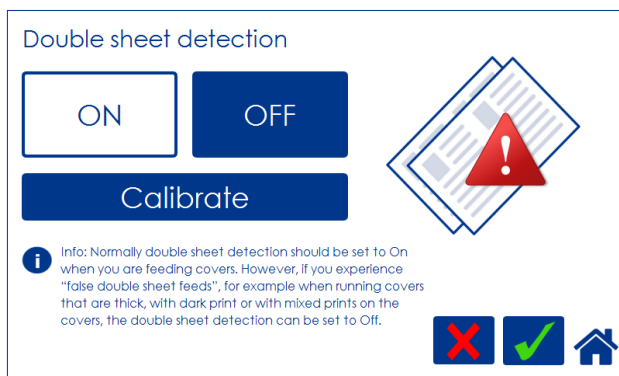

From the Cover screen, press the [Double sheet detection] button. Set the detection to On or Off by pressing the corresponding button and save setting by pressing the green [check] button.

Normally, double sheet detection should be set to “On” when you are feeding covers. However, if you experience “false double sheet feeds”, for example when running covers that are thick, with dark print or with mixed prints on the covers, the double sheet detection can be set to Off.



NOTE:

Misfeed detection will work regardless of how Double Sheet detection is set.

Purge Cover

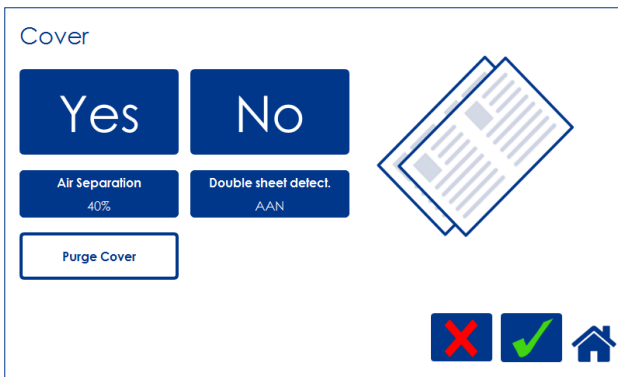

The Purge mode is used when you want to completely empty the Cover Feeder from covers.

- 1 Remove all cover sheets from the bin.
- 2 Press the [Purge Cover] button and confirm by pressing the green [check] button. The pre-fed cover sheet will now be fed into the Booklet Maker to the stapling area, but will not be stapled.
- 3 Open top cover and remove the cover sheet.

NOTE:

If you open and close the top cover without removing the cover sheet, the cover sheet will be stapled and folded and then fed to the stacker.

BookFold

General

The BookFold Module has three different settings - Manual, Auto and Off. In Manual mode, there are eight different modes of BookFold pressure to choose from. Set to Auto, information from the set thickness sensor in the Booklet Maker is used to calculate the most appropriate mode between 1 and 7. See guidance table below. Select Off to bypass the BookFold Module without any square forming action.

NOTE:

When the BookFold Module is set to Auto and the booklet has less than approximately 6 sheets/booklet, the BookFold Module will bypass the square forming action. For some jobs, Auto mode may not provide the optimum result. In this case, fine tune by selecting a mode in Manual mode - see the table below.

Mode 8 is a heavy duty setting in case of extra demanding media. Mode 8 is not included in the Auto setting and therefore must be selected manually.

Use the manual modes to override the auto function. There are eight different manual modes to select from.

Table below is approximate numbers and is based on 80 gsm / 20 lb Bond sheets.

Mode	Number of sheets in the set	Notes
1	Approximately 6 to 10	
2	Approximately 11 to 16	
3	Approximately 17 to 22	
4	Approximately 23 to 29	
5	Approximately 30 to 35	
6	Approximately 36 to 43	
7	Approximately 44 to 50	
8	Heavy duty setting in case of extra demanding media.	

BookFold pressure settings guidance table

continued on next page

The table below shows highest supported BookFold pressure settings on BLM35 and BLM50 Production Booklet Maker systems.

NOTE:

The following table indicates maximum BookFold pressure setting that can be used on the Production Booklet Maker systems without slowing the printer down.

Number of sheets	A4	A3	SRA3	8.5x11"	11x17"	12x18"
1-5	2	4	7	1	4	7
6-10	4	7	8	4	7	8
11-15	7	8	8	7	8	8
16-20	7	8	8	7	8	8
21-30	8	8	8	8	8	8
31-50	8	8	8	8	8	8

NOTE:

When square forming thick booklets with a thin cover, the cover sheet may be spaced away from the body of the book and/or it may be crushed in the square forming process.

This phenomenon is eliminated/reduced by using a heavier media as the cover. If using a heavier cover is not an option, using a lower BookFold pressure setting in the square forming process may improve booklet appearance.

Selecting BookFold pressure setting

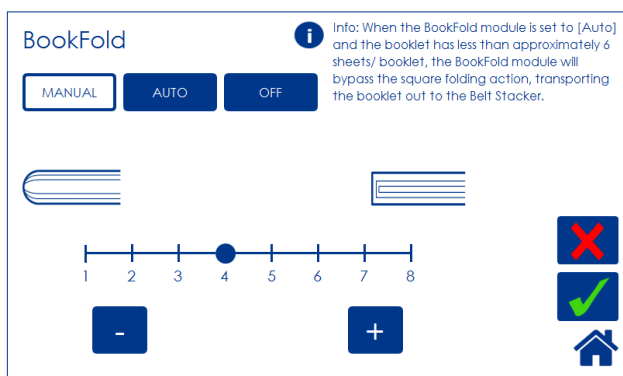

From the Settings for Booklet Production screen, press the [BookFold] button.

Press the [Manual] button and select the desired amount of pressure using the [+] and [-] buttons. Save setting by pressing the green [check] button.

Crease

The Crease function makes it possible to crease the cover sheet of the booklet in order to avoid toner cracking or flaking at the fold.

Crease Mode

2

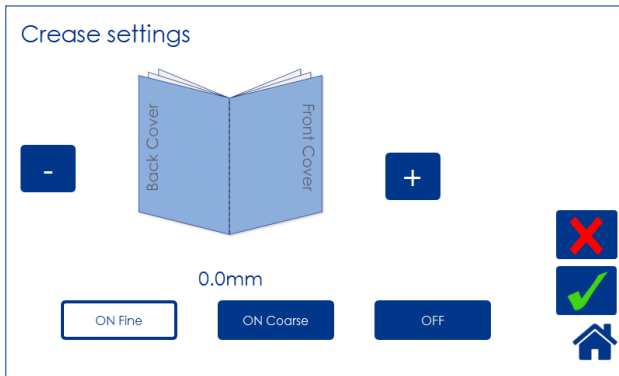

From the Settings for Booklet Production screen, press the [Crease] button.

Press the corresponding button to choose [On Fine], [On Coarse] or [OFF].

Fine is recommended for cover sheets less than 120 gsm / 32 lb Bond.

For sheets heavier than that, select Coarse.

When you want to turn the Creaser off, select Off.

Press the green [check] button to confirm.

Crease position

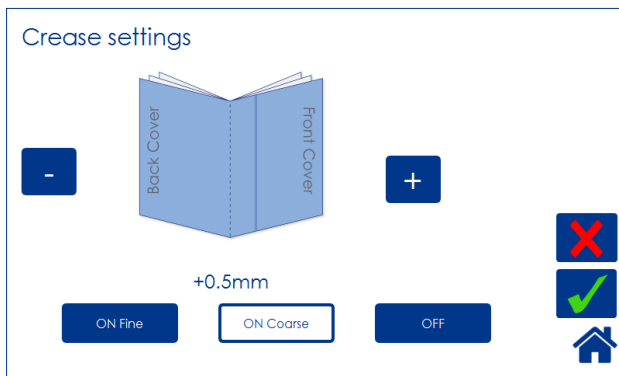

The crease is initially set to the center of the sheet. Operators have the option to offset the position of the crease using the [+] or [-] buttons. Press the [+] button move position closer to the lead edge and press the [-] button move position closer to the trail edge. Regardless if you chose Fine or Coarse creasing, each press of a button will move the crease 0.1 mm / 0.004".

When done, press the green [check] button to confirm.

The illustration shows that the crease is offset 0.5 mm towards the trail edge.

Fine-tuning booklet appearance

Set registration (fine adjustment)

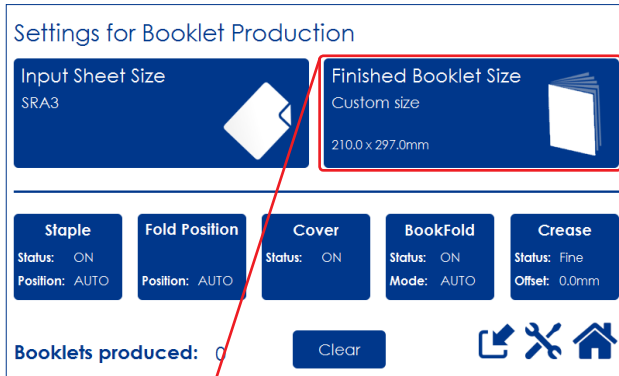

You can fine-tune the booklet quality by adjusting the jiggers in the booklet maker. From the Settings for Booklet Production screen, press the [Finished Booklet Size] button.

2

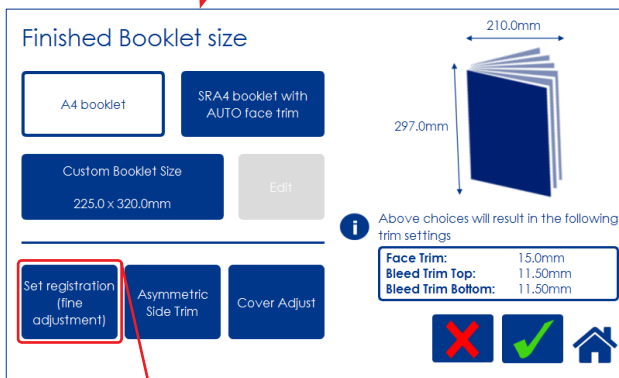

From the Finished Booklet size screen, press the [Set registration (fine adjustment)] button.

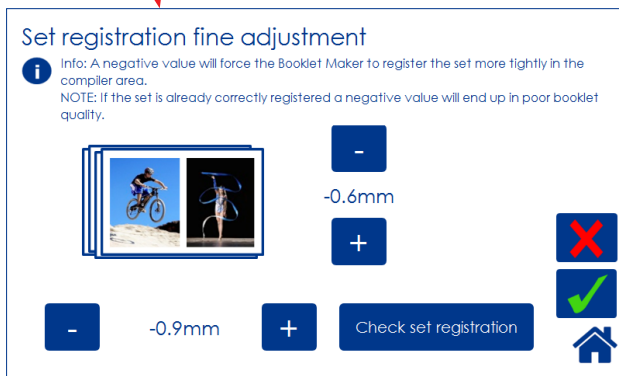

Press the [-] and [+] buttons to alter either or both registration values. Negative value means a tighter registration.

NOTE:
Too tight of a setting may worsen the result.

After setting registration value, press the [Check set registration] button and follow the instructions on screen.

If you are satisfied with the registration, confirm by pressing the green [check] button. If not, press the [-] and [+] buttons to enter new value. Check out the new value by pressing the [Verify adjustments] button.

Press the green [check] button when you are satisfied.

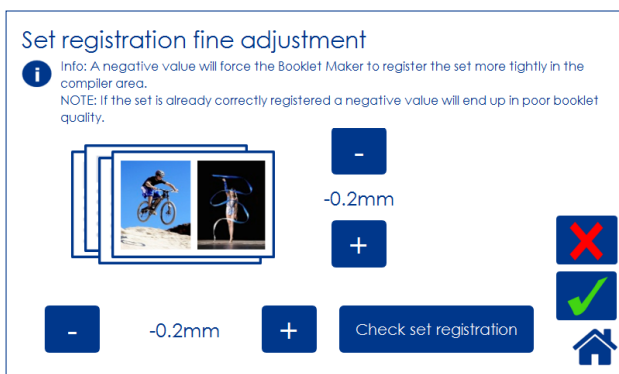

Bleed Trimmer - Asymmetric Side Trim

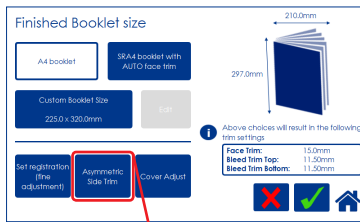

2

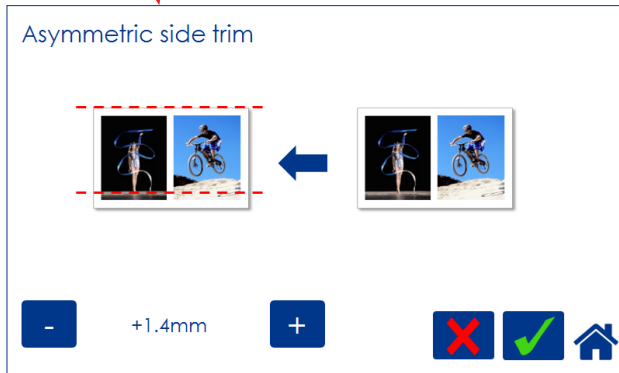

From the Finished Booklet size screen, press the [Asymmetric Side Trim] button.

Choose Asymmetric Side Trim if you want to offset the bleed trim. Move using the [+] and [-] buttons and press the green [check] button to save setting.

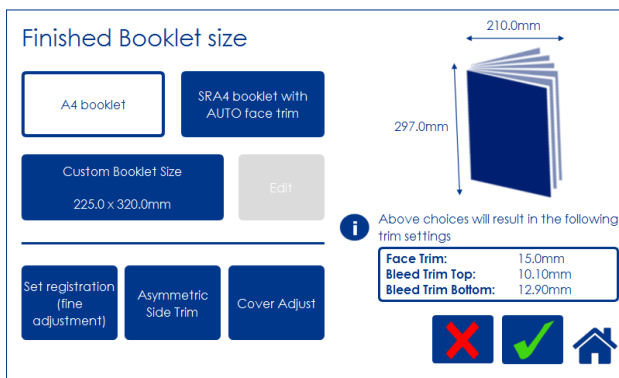

Settings as in the example above would result in a booklet with trim settings shown in the image to the left.

Bleed Trimmer - Cover Adjust

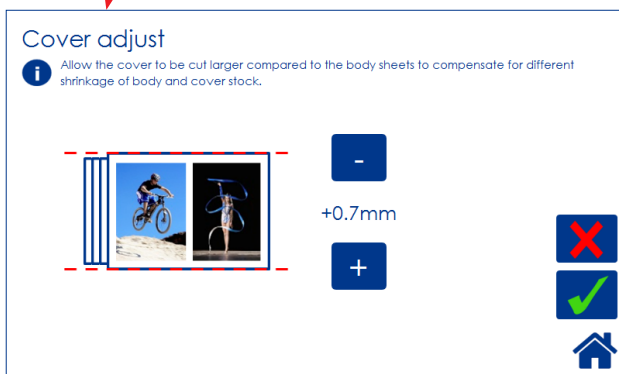
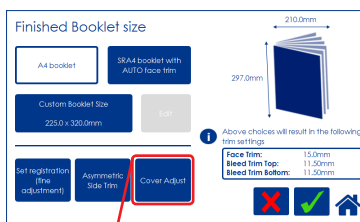

From the Finished Booklet size screen, press the [Cover Adjust] button.

Choose Cover Adjust to compensate for different shrinkage of body- and booklet cover stock. This can occur under some conditions and can be caused by different paper stocks shrinking due to the heat and pressure of the fusing process.

Adjusting these settings can improve booklet appearance, especially if the cover is dark and the body sheets are bright.

The shown example will make the cover sheet 0.7mm bigger than the body stock.

Hand-feeding

The Booklet maker can be operated in two modes. On-line mode, when used together with the printer, or off-line mode, working as a stand-alone unit.

Hand feed mode

2

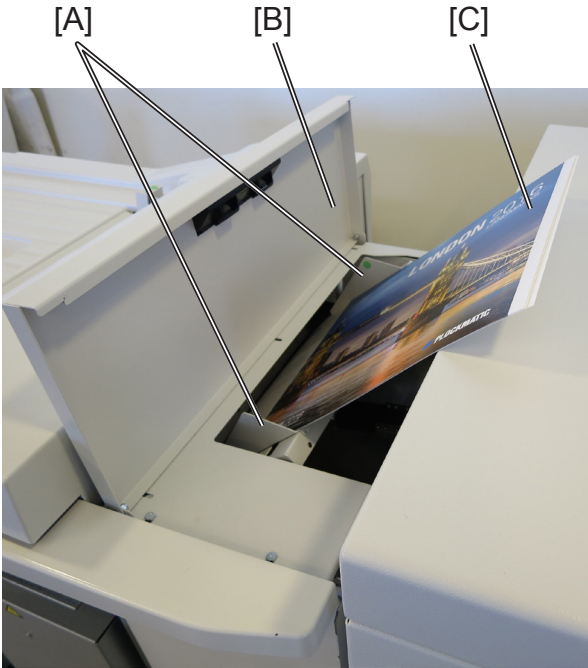

- 1** Setup the Booklet Maker to the correct paper size.
- 2** Open the Hand Feed Cover [B].
- 3** Adjust the hand feeding paper guides [A] to the correct paper size.
- 4** Start hand feeding sets [C] when the text [Ready to feed!] is shown in the user interface.
- 5** To stop hand feeding, close the Hand Feed Cover.



NOTE:
RCT features will not be available.

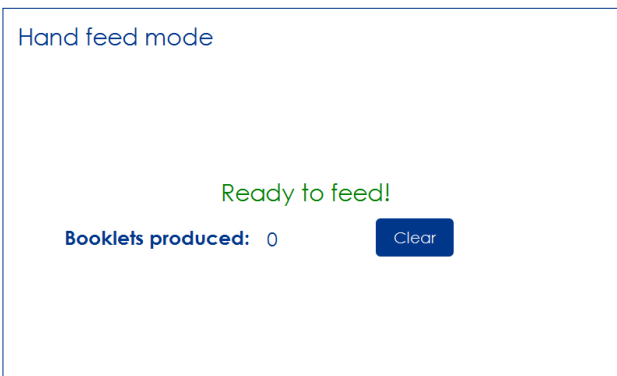

Page intentionally blank.

3. Tools

The Tools screen

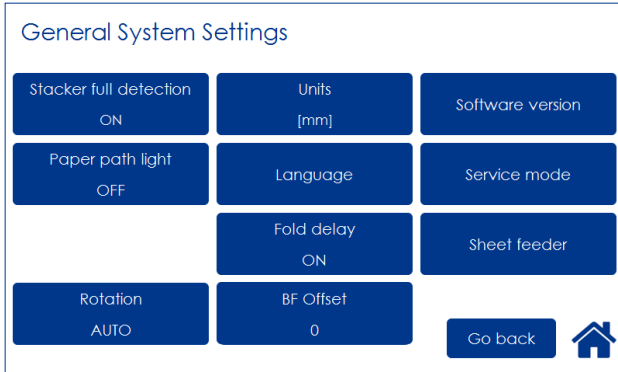

 From the Start screen or the Settings for Booklet Production screen, press the [Tools] button to get to the General System Settings screen. Select the setting you want to change by pressing the corresponding button.

Press the green [check] button to save your changes.

Stacker full detection

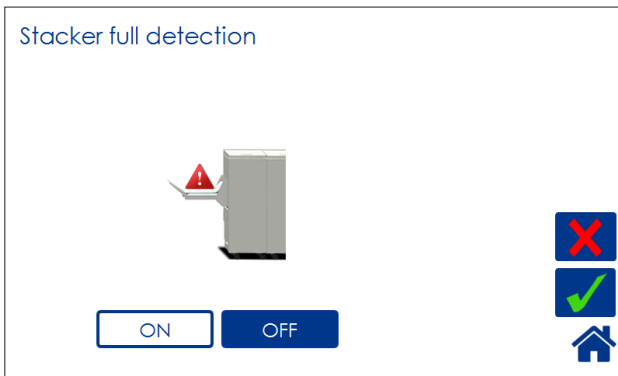

Set Stacker Full Detection to ON if you want the system to stop and cycle down when the stacker is full.

Units

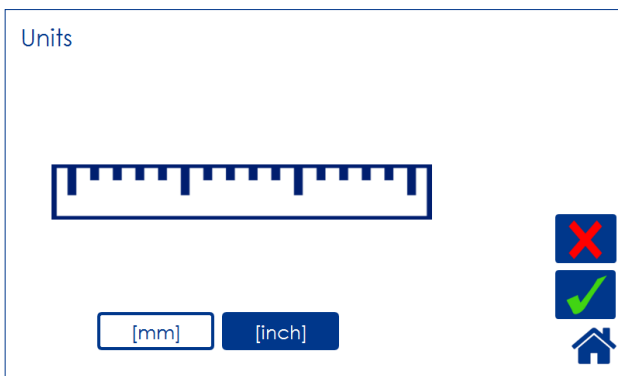

Select millimeters or inches by pressing the corresponding button.

Software version

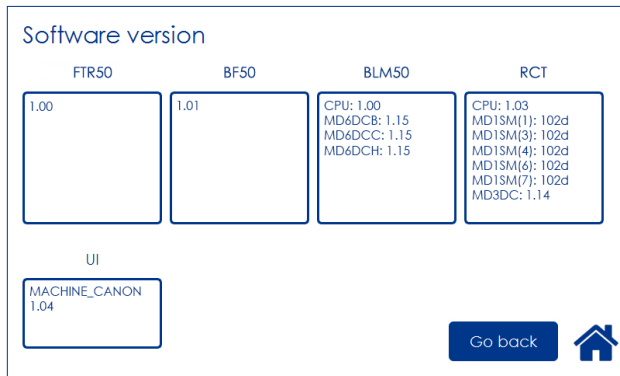

Select module by pressing the corresponding button to display the software version. Press [Exit] button to go back to the Settings screen.

3

Paper path light

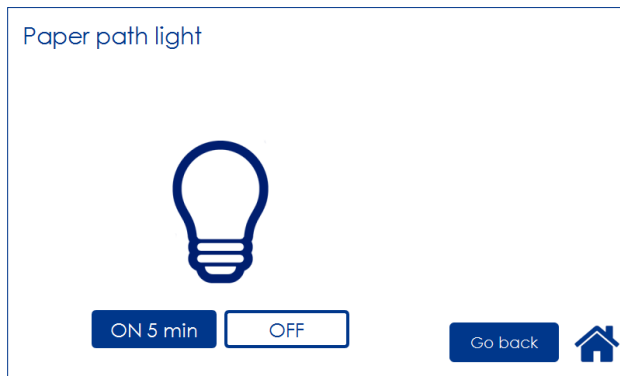

This function is for service purposes. To turn the paper path light on, press [ON 5 min] button and save by pressing the [OK] button.

Language



Select desired language by pressing the corresponding button.

Service mode

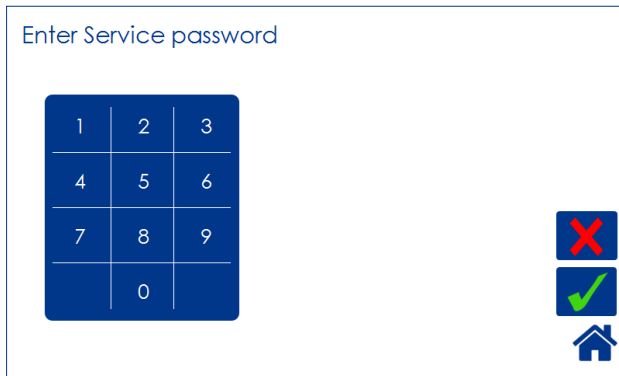

This function is for authorized service personnel only and is password protected.

Fold delay

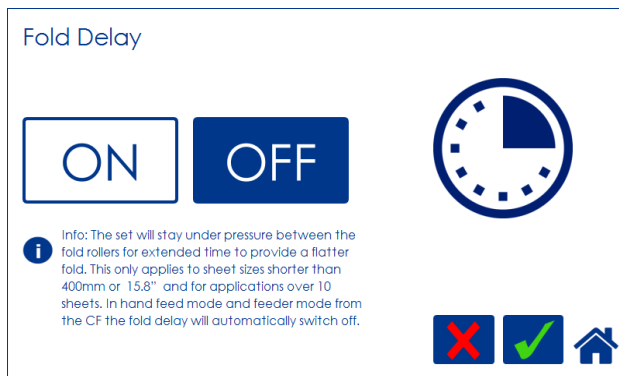

With this feature, the set will stay under pressure between the fold rollers for an extended time to provide a flatter fold. This only applies to sheet sizes shorter than 400mm or 15.8” and for applications over 10 sheets. In hand feed mode and feeder mode from the CF, the fold delay will automatically switch off.

Sheet feeder

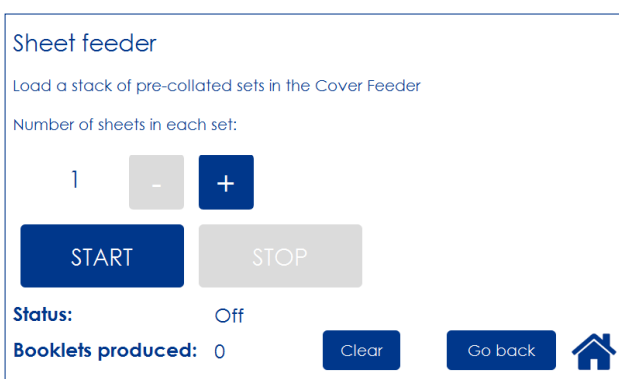

This function allows you to use the Cover Feeder as a regular Feeder. Load the Cover Feeder, enter the desired number of sheets in each set and press the [Start] button to begin folding. Press the [Stop] button to stop.

See section 1, “Basics”, for how to load the cover feeder.

See section 2, “Making Booklets” for how to adjust Air Separation and Double sheet detection.

 **NOTE:**

To avoid the error message “Load covers”, load covers before pressing the [START] button.

Auto Rotate

Auto Rotate

i Info: Auto Rotate will automatically rotate ALL sheet sizes sent from the printer in long edge feed to the Booklet Maker system. Recommendation is to keep this ON most of the time.



Auto Rotate
OFF

Auto Rotate
ON



3

If your system includes the optional RCT module, you can select whether you want Auto Rotate function to be ON or OFF by pressing the corresponding button.

It is recommended to keep this ON. When turned on, the Rotator will automatically rotate all sheet sizes sent from the printer in long edge feed, enabling higher printer productivity.

Selecting OFF will prevent sheets from being rotated when possible. Sheet length has to exceed 275mm / 10.6". Otherwise Auto Rotate will automatically be changed to ON and sheets will be rotated.

BookFold offset

The BookFold pressure setting is set to a standard that should suit most applications. Operators have the option of sharpening or softening the square edges based on application or preference. Customizing this setting will affect modes 1 to 7 but not mode 8.

BookFold offset

i Info: Changing this value will apply to all jobs using the BookFold feature. Only change this offset value if you think the AUTO setting of the BF module always produces a weak square fold.



-10

0

+10

-

+



Select sharper edges by pressing the [+] button or softer edges by pressing the [-] button.



NOTE:

BookFold Offset affects modes 1 -7 only.

4. Jobs

Handling jobs

The Booklet Maker has a maximum storage capacity of 20 different jobs. To make temporary changes in the actual job settings or temporary changes of a stored job, see section 2, "Making Booklets."

From the Start screen, press the [Jobs] button to be able to store, change or delete jobs.

Saving a Job

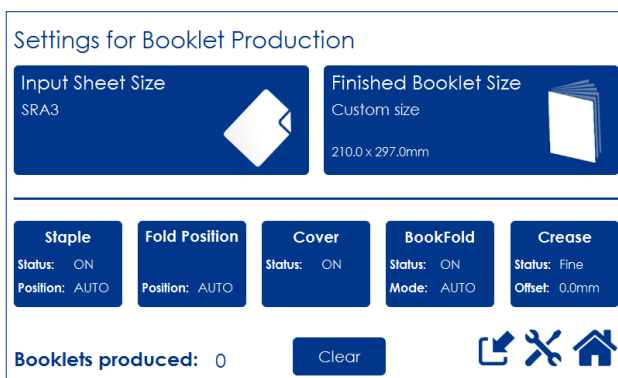

To store a job, press  from the **Settings for Booklet Production** screen.

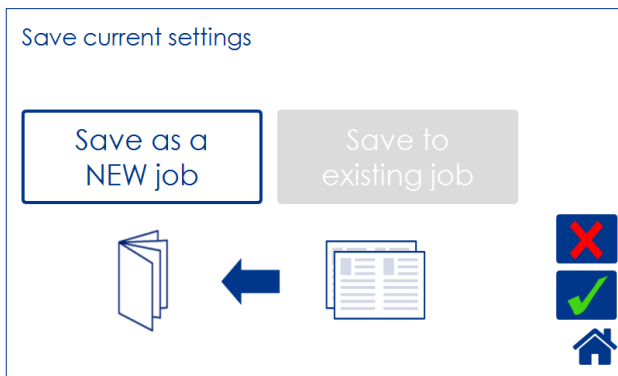

Press the [Save as a NEW job] button and then press the green [check] button to continue.

The [Save to existing job] button is only available if a job is currently loaded.

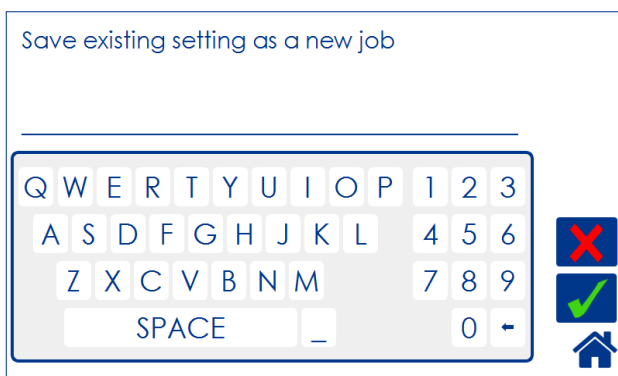

Enter a job name and save by pressing the green [check] button.

To delete last character, press the [←] button

Opening and handling stored Jobs

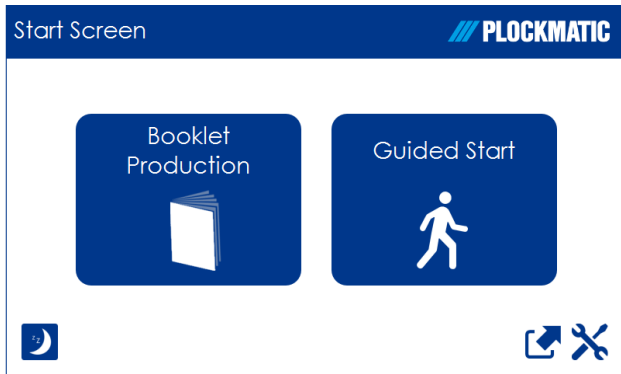

To access already stored jobs, press  from the **Start Screen**.

4

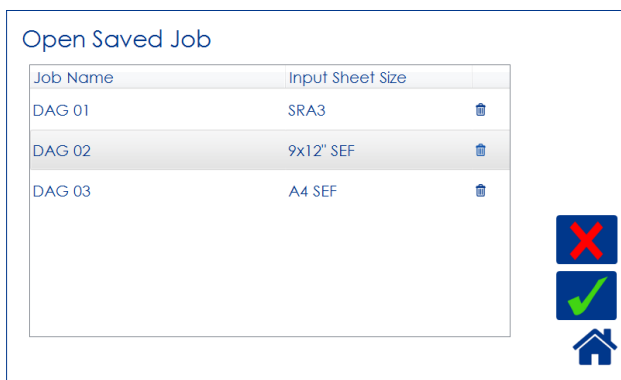

Open (load) any stored job by pressing the job and confirm by pressing the green [check] mark.

Delete any stored job by pressing the job button, the waste bin symbol and then confirm by pressing the [Yes] button.

 **NOTE:**
The currently loaded job cannot be deleted.

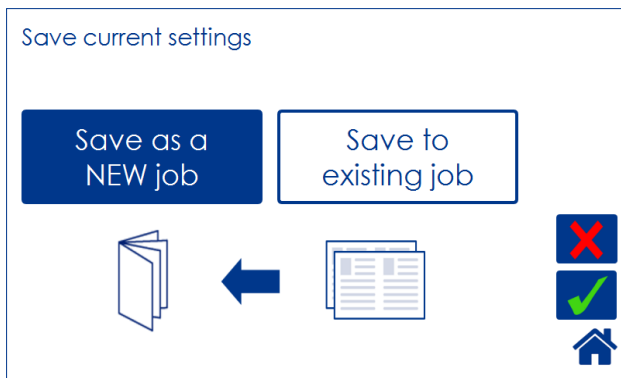

The button [Save to existing job] is only available if a saved job is currently loaded. Press the [Save to existing job] button to overwrite the currently loaded job.

Press the green [check] button to confirm.

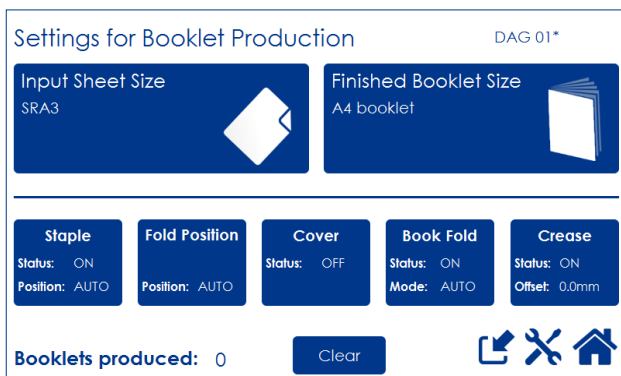

The name of the currently loaded job is shown in the upper right corner. An asterisk next to the name shows that changes to the job have been made and that the changes have not yet been saved.

5. Clearing Misfeed(s)

Clearing misfeed(s)

General

If a misfeed condition should occur, it is indicated on the Booklet Maker display. The message “Clear Misfeed(s)”, an error code and the location of the misfeed is displayed. See examples below.

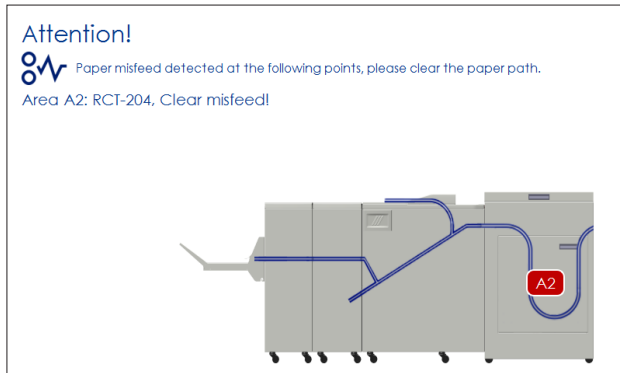

Misfeeds in the Rotate Crease Trim Module are indicated by the error code RCT-XXX.

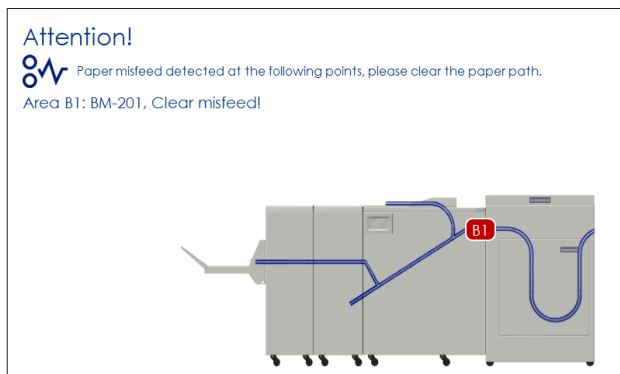

Misfeeds in the Booklet Maker are indicated by the error code BM-XXX and visually where in the Booklet Maker (B1, B2 or B3) the misfeed occurred.

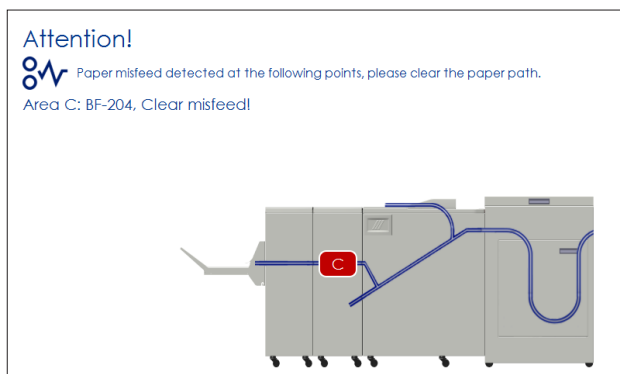

Misfeeds in the BookFold Module are indicated by the error code BF-XXX.

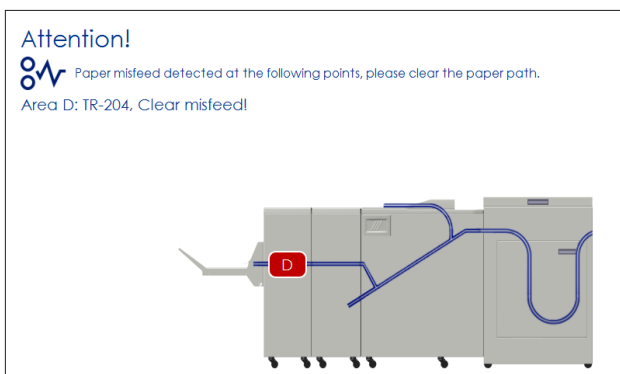

Misfeeds in the Trimmer are indicated by the error code TR-XXX.

RCT Module

Clearing misfeed(s)

Infeed "A" area and exit "D" area

- 1 Open the RCT top cover.
- 2 Lift up baffles "A" and "D" if needed.
- 3 Remove any misfeed(s).
- 4 Lower baffles "A" and "D" to normal position
- 5 Misfeed(s) in the trimmer area are rolled out by rotating the rubber surfaced pinch roller [A].
- 6 Close the top cover.

5

⚠ WARNING

**Do not put your fingers within knife protections (B).
Doing so may result in injury.**

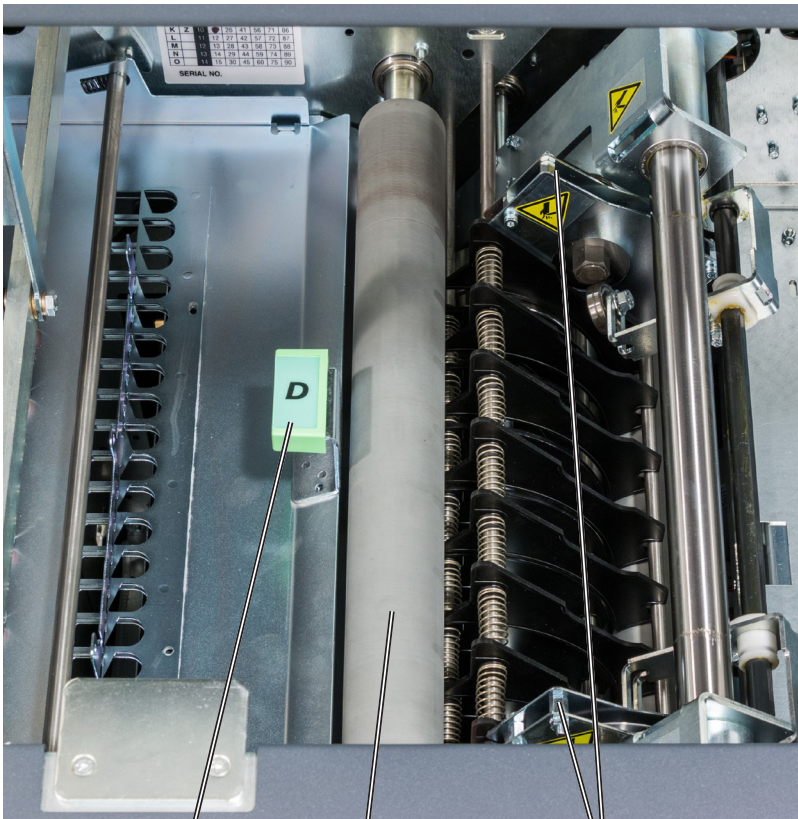

Baffle D

[A]

[B]



Baffle A

Registration and creaser area

- 1 Open the slide door [A].
- 2 Unlatch and pull out the slide [B].
- 3 Open baffles "B" and "C" if needed.
- 4 Remove any misfeed(s).
- 5 Close baffles "B" and "C".
- 6 Push in and latch the slide.
- 7 Always remove any residual waste from waste channel and waste [C] belt before closing the slide door.
- 8 Close the slide door.

Clearing jams in the waste transport

5

The waste transport is easily accessible through the slide door. Shreds jammed in or wrapped around the knife assembly are also accessible through the slide door.

CAUTION

Under no circumstances should jams around the trimmer blades be cleared using metallic tools. The edges are very fragile and easily damaged.

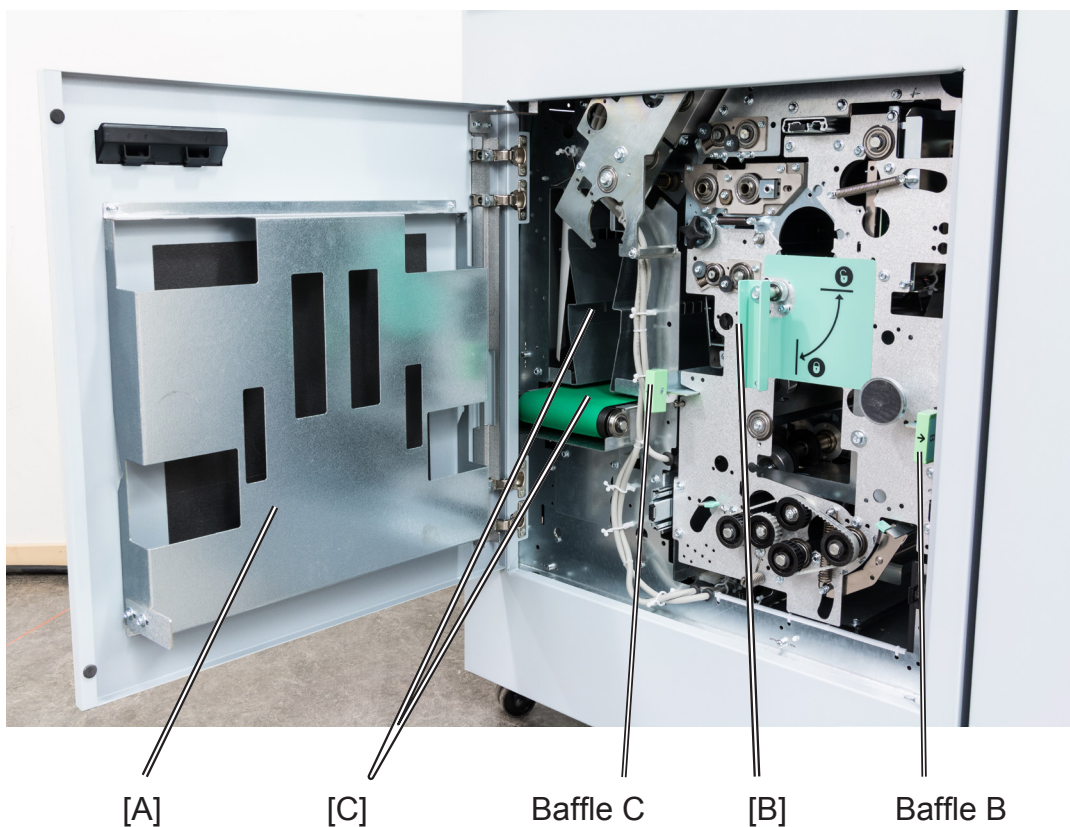

Booklet Maker

Clearing misfeed(s)

Inside the Booklet Maker

5

Attention!

 Paper misfeed detected at the following points, please clear the paper path.
Area B1: BM-201. Clear misfeed!

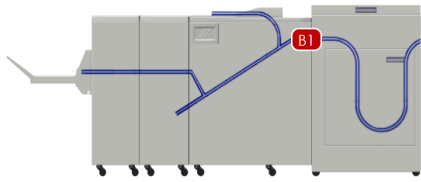

To clear a misfeed indicated in Area B1

- 1 Open the top cover.
- 2 Remove misfed sheets.
- 3 Close the top cover.

Attention!

 Paper misfeed detected at the following points, please clear the paper path.
Area B2: BM-204. Clear misfeed!

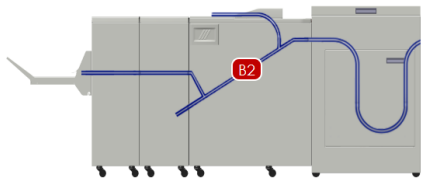

To clear a misfeed indicated in Area B2

- 1 Open the top cover.
- 2 Close top cover.

If system does not purge, open top cover and remove misfed sheets manually.

Attention!

 Paper misfeed detected at the following points, please clear the paper path.
Area B3: BM-207. Clear misfeed!

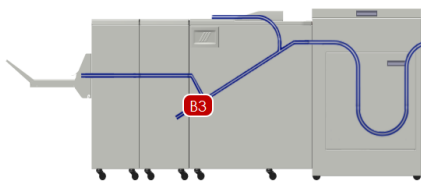

To clear a misfeed indicated in Area B3

- 1 Open the top cover.
- 2 Close top cover.

If misfeed condition remains:

- 1 Switch off the main power.
- 2 Switch on the main power.

Clearing misfeed(s), continued

Clearing misfeed in infeed area

- 1 Open the top cover.
- 2 Lift the paper guide [A] as shown in picture.
- 3 Remove misfed sheets.
- 4 Close top cover.

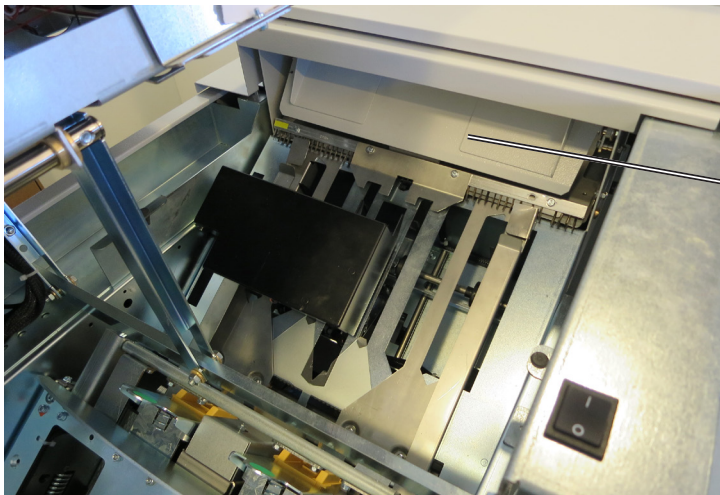

5

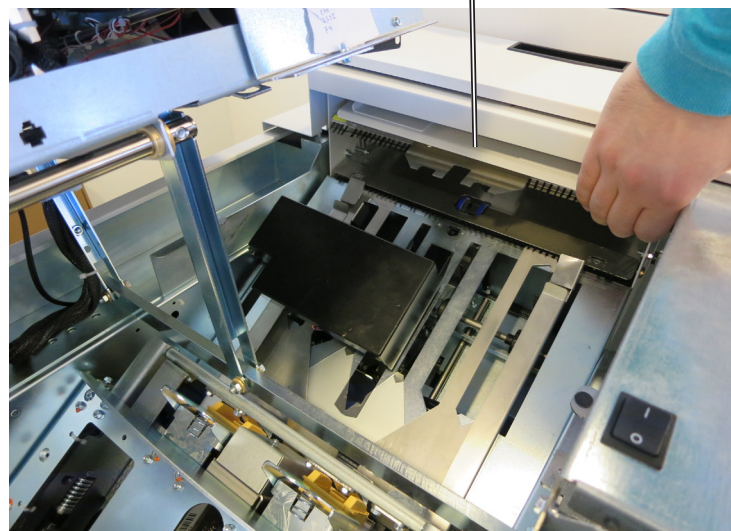

Clearing misfeed(s), continued

Clearing misfeed in folder area

- 1 Open the top cover.
- 2 Open the fold roller paper guide [A] by pushing (arrow 1), lifting (arrow 2) and pivoting (arrow 3) to access any misfed or jammed sheets/booklets between the lower and upper pair of fold rollers.
- 3 Remove sheets/booklets in folder area between fold rollers.
- 4 In reversed manner, place the fold roller paper guide back in operating position.

 **NOTE:**

5 Make sure the fold roller paper guide is locked in operating position [B] at both sides.

- 5 Close top cover.

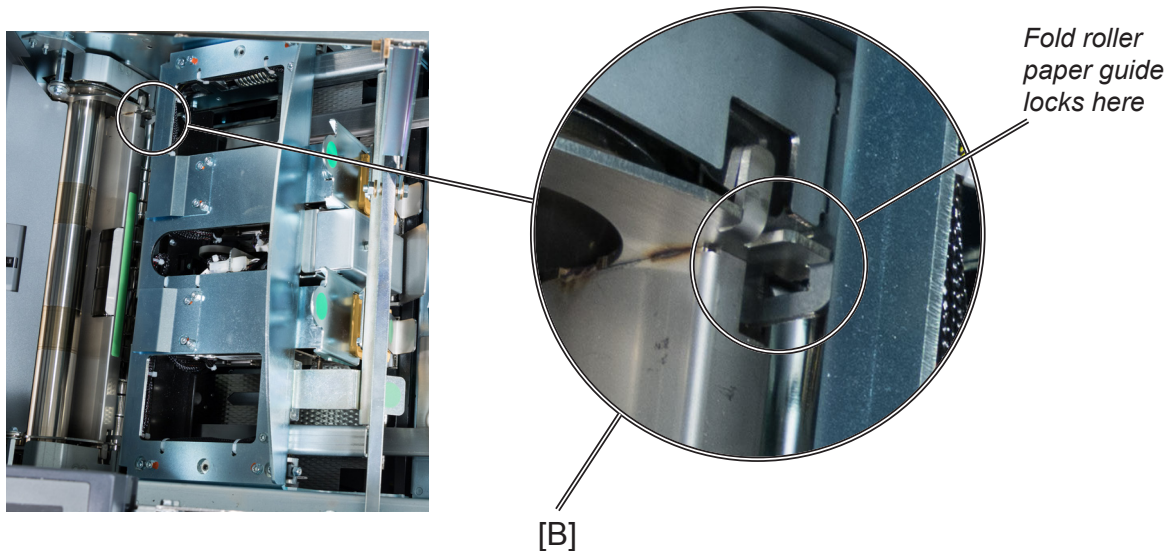

Cover Feeder

Clearing misfeed(s) in vertical transport area

- 1 Open the top cover [A].
- 2 Lift the jam clearance baffle [B].
- 3 Remove the misfed sheet.
- 4 Put the jam clearance baffle back in normal position.

 **NOTE:**

In case of a cover feeding jam/error, it is difficult to remove a stuck cover due to the very strong separation nip. Removing the stack of sheets and then lifting the jam clearance baffle is the easiest way to remove a cover that is stuck.

5

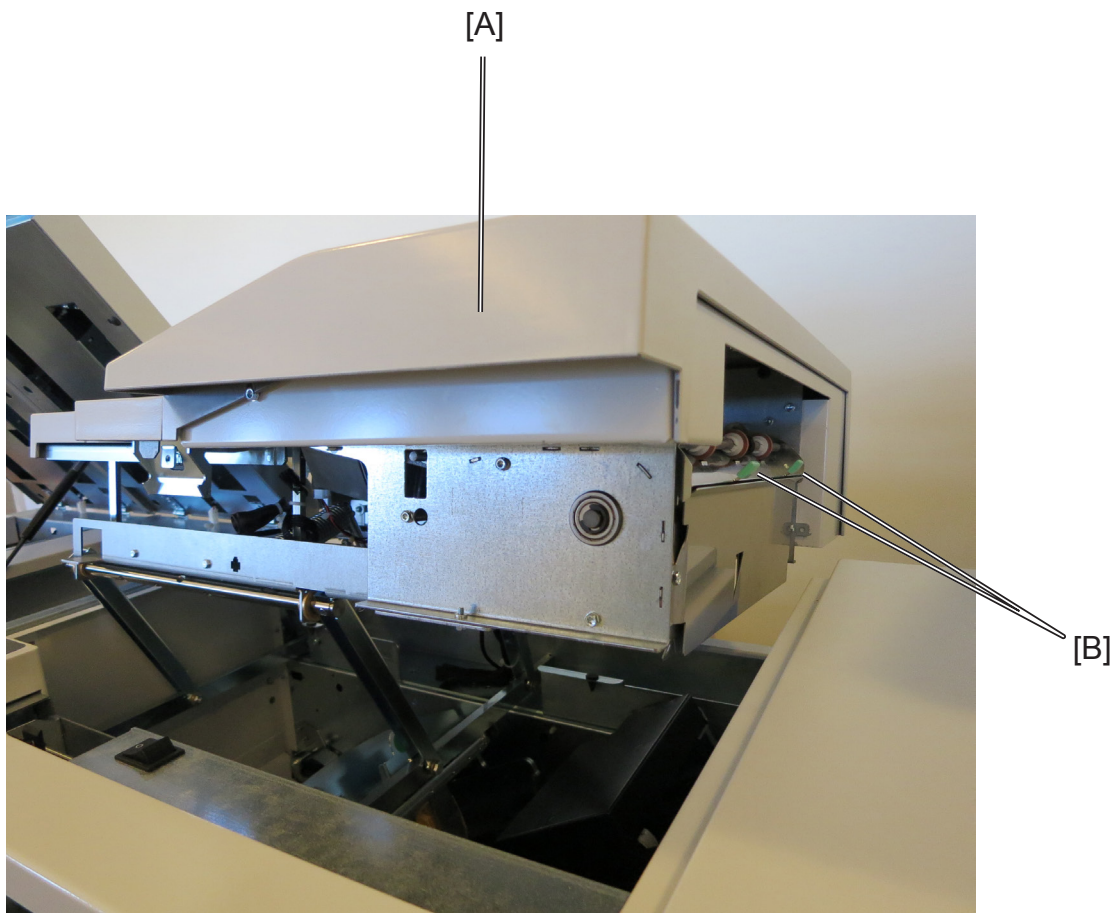

BookFold Module

Clearing misfeed(s)

Inside the BookFold Module

- 1 Open the top cover.
- 2 Lift up upper feed belts (A) to access jammed/misfed booklets.

 **NOTE:**

Press the green dots (B) (only one visible in picture) on the latches to release.

- 3 Remove the jammed/misfed booklets.
- 4 Place the upper feed belts in normal position.

5

- 5 Close the top cover.

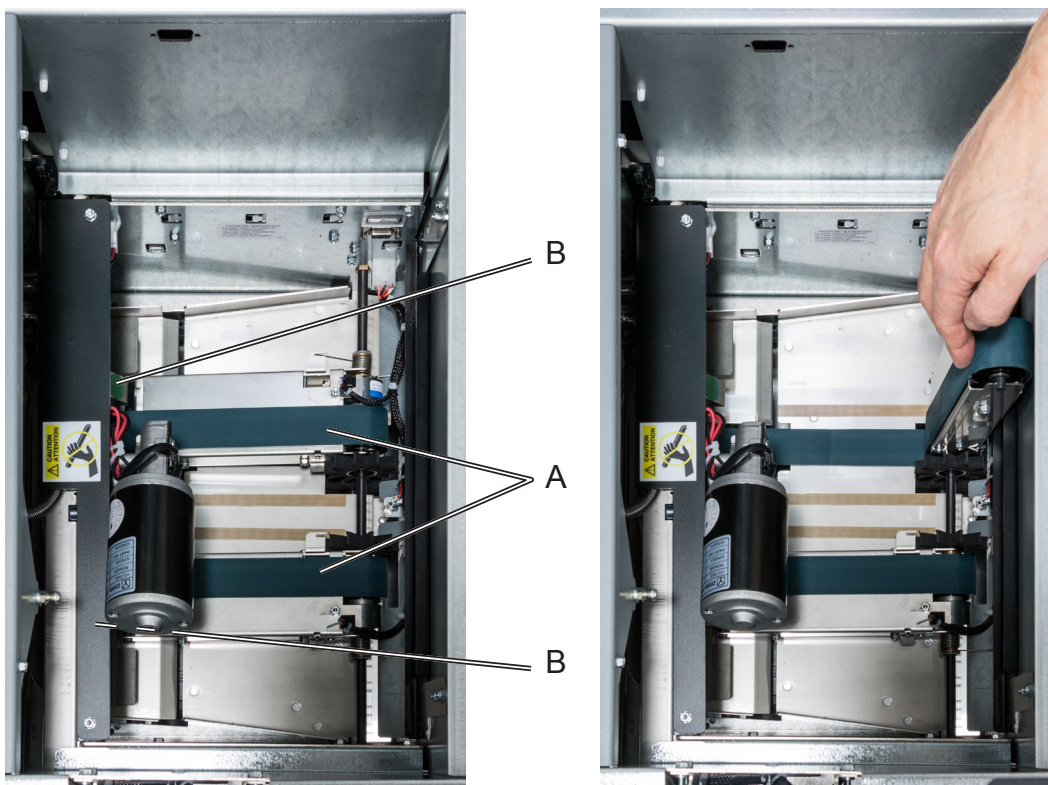

 **NOTE:**

The upper feed belt on the operator side cannot be lifted fully.

Trimmer

Clearing misfeed(s)

The upper trimmer blade on the trimmer is protected by a knife protection plate that moves away during the cutting stroke.

⚠ WARNING

Never put fingers or other body parts between the upper and lower trimmer knives.

Clearing misfeed in input area

- 1** Raise the rightmost side of the infeed roller shaft assembly (A).
- 2** Remove the misfed sheets in the infeed area.
- 3** After the misfed sheets are removed, place the infeed roller shaft assembly into operating position.

5



infeed roller shaft assy. in normal position



infeed roller shaft assy. lifted

Clearing misfeed(s), continued

Clearing misfeed in exit area

- 1** Lift the exit compressing brackets and transport belts [B] at the green dot.
- 2** Secure using the latch [C]. Not clearly visible in picture
- 3** Remove the misfed sheets from the exit area.
- 4** After the misfed sheets are removed, release the latch [C] and place the exit compressing brackets in operating position.

5

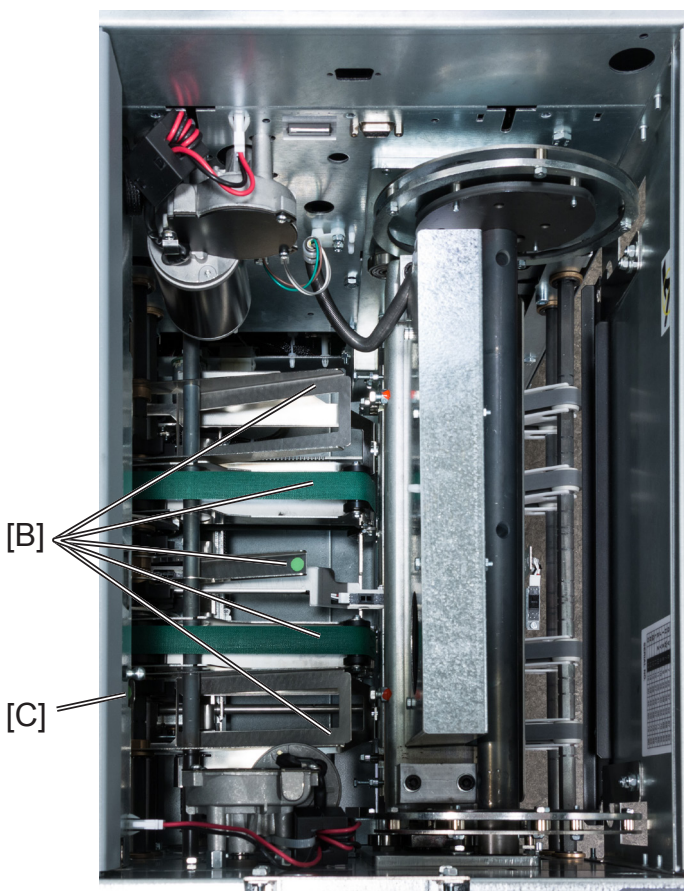

Exit compressing brackets in normal position

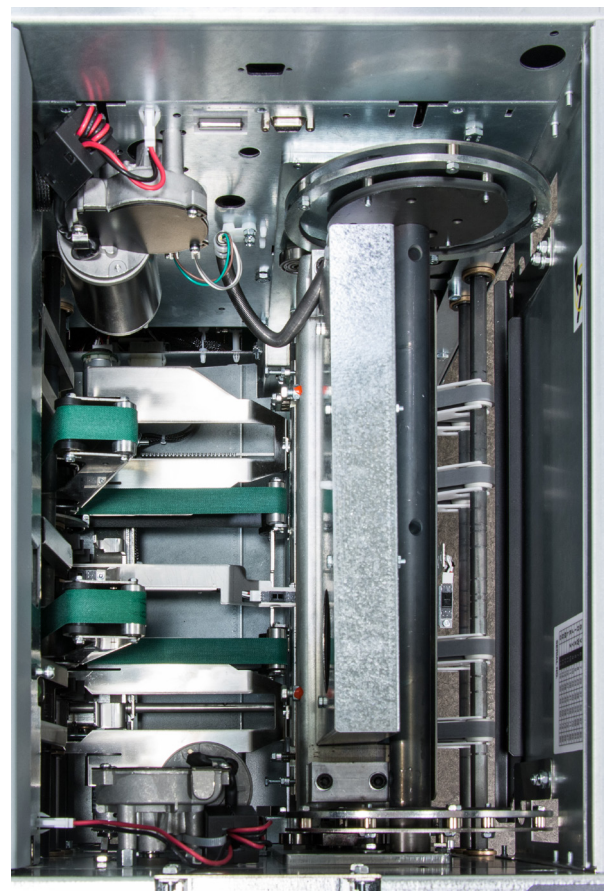

Exit compressing brackets lifted

Belt Stacker

Clearing misfeed(s)

Clearing misfeed on belt stacker

- 1** Lift the belt stacker exit cover (A).
- 2** Remove jammed/misfed booklets.
- 3** Place belt stacker exit cover back in operating position.

5

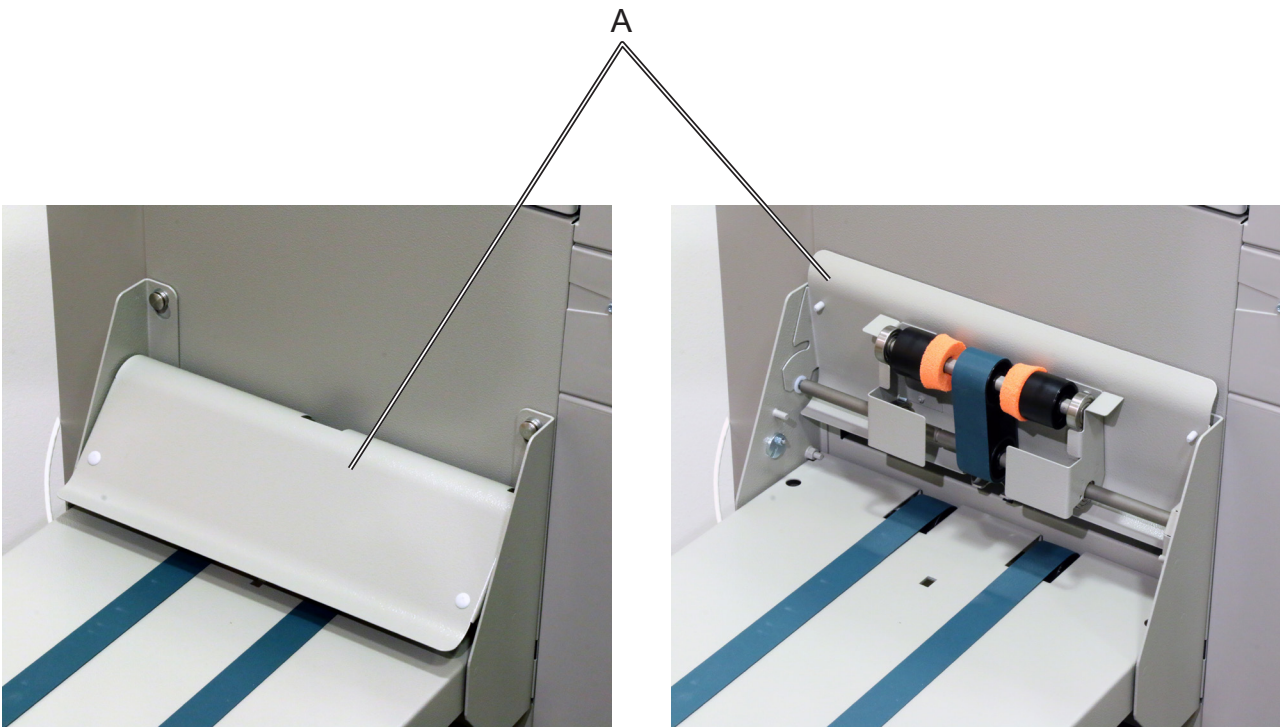

Page intentionally blank.

6. Troubleshooting

Fault codes

General

When there is a misfeed or fault condition in the Booklet Maker system, a code and/or a message will be displayed on the UI. Table and fault code descriptions below will guide you troubleshooting.

If frequent input jams are experienced please check paper curl and de-curler adjustments in printer operator guide.

For fault codes other than specified below - remove any paper in the paper path and power Off and On the system.

 **NOTE:**

If procedures in this manual do not rectify the problem an authorized technician will be needed.

RCT fault codes

RCT Module

Code / message	Explanation / action
RCT-001 - RCT-171 Possible fault in area, please power off and power on to recover!	Indicates that there might be an internal communication error between the RCT module and the Booklet Maker. Check that the RCT is powered up and that the communication cable between the RCT module and the Booklet Maker is OK. Power off and on the system. If problem persists, contact customer support.
RCT201 - RCT212 and RCT230 Clear misfeed!	A misfeed has occurred in the RCT module. See section 5, "Clearing Misfeed(s)" for how to clear misfeed(s). If feed errors occurs in the paper path or in the waste transport system, check for obstructions. If no obvious obstructions are found, see section 7, "REMARKS" Maintaining Your Machine.
Empty trim bin from RCT module and check waste belt!	Check / Empty Waste container and check Waste Transport for buildup of trim waste strips. It is highly recommended to empty the waste box whenever the system stops to keep up productivity.

Booklet Maker fault codes

Booklet Maker

Code / message	Explanation / action
BM-001 - BM-169 Possible fault in area, please power off and power on to recover!	Indicates that there might be an internal communication error. Power off and on the system. If problem persists, contact customer support.
BM-170, Incompatible RCT software!	Software in the RCT is reported to be of an incompatible version. Power off and on the system. If problem persists, contact customer support.
BM-201 - BM-208 Clear misfeed!	A misfeed has occurred in the Booklet maker. See section 5, "Clearing Misfeed(s)" for how to clear misfeed(s).
BM-401, Check right stapler! BM-402, Check left stapler! BM-403, Check right and left stapler!	Indicates jam in either or both staplers. Check staple cartridge(s) according to procedure in section 1, "Basics."
BM-404, Set too thick, remove set from booklet maker!	Indicates that the set from the copier is outside Booklet Maker specifications and is too thick to be folded. Open top cover and remove set. Close top cover.
BM-407 Too many sheets, remove set and reduce number of sheets in the job!	Indicating there are too many sheets in the Booklet Maker. Open top cover and remove set. Close top cover. Reduce the number of sheets in the job.
BM-408 CF empty, remove incomplete set from Booklet Maker!	Using the Cover Feeder as a regular feeder, the bin has run out of sheets before a set was completed. Open top cover and remove the incomplete set from the Booklet Maker.
BM-600 - BM-617 File error!	Indicates that there might be an internal communication error. Power off and on the system. If problem persists, contact customer support.
Replace right staple cartridge! Replace left staple cartridge! Replace right and left staple cartridges!	Indicates almost out of staples in either or both staplers. Change staple cartridge(s) according to procedure in section 1, "Basics."
Remove purged cover from inside booklet maker!	There is a purged cover inside the Booklet Maker. Open top cover and remove set. Close top cover.
Size mismatch! Hold the job in the printer and check paper size settings.	There is a mismatch between paper size in the printer and the Booklet Maker. Input sheet size in the Booklet Maker is automatically set to AUTO. Press the [Done] button to continue with the Booklet Maker in AUTO mode or hold the printer and a check paper size settings.

Cover Feeder fault codes

Cover Feeder

Code / message	Explanation / action
CF-001 - CF-012 Possible fault in area, please power off and power on to recover!	Indicates that there might be an internal communication error. Power off and on the system. If problem persists, contact customer support.
CF-201 Out of covers, remove sheets from Booklet Maker!	Indicates "Out of covers" in the Cover Feeder. Load covers according to section 1, "Basics."
CF-202 - CF205 and CF-207 Clear misfeed!	A misfeed has occurred in the Cover Feeder. Check cover loading according to section 1, "Basics", Cover Feeder. If problem persists, clean separator pad according to section 7, "REMARKS."
Double feed from CF, remove double from inside the booklet maker.	A double feed has occurred in the Cover Feeder. If there was a true double: <ol style="list-style-type: none"> 1. Check for proper loading of covers according to section 1, "Basics", Cover Feeder. 2. Increase air flow according to section 2, "Making Booklets." 3. Clean feed belts according to section 7, "REMARKS", Maintaining your machines. If there is a false double: <ol style="list-style-type: none"> 1. Check that covers are within specification. 2. Temporary turn double sheet detection off. See section 2, "Making Booklets", Customizing settings. If the covers fed are thick, with dark print or with mixed prints on the covers, double feeding may be displayed even if that is not the case.
Cover size not equal to paper size. Change cover size!	Indicates that there is a format mismatch between the sheets loaded in the Cover Feeder and the sheets in the Booklet Maker. There are two options: <ol style="list-style-type: none"> 1. Correct either mismatch and press the [Done] button. 2. Turn the Cover Feeder off by pressing the [Turn cover off] button to continue booklet making but without feeding covers.

Cover Feeder fault codes, continued

Cover Feeder, continued

Code / message	Explanation / action
Cover stack is low, please add covers!	<p>Indicates that the Cover Feeder is almost out of Covers. There are two ways to continue operation.</p> <ol style="list-style-type: none"> 1. Loading more cover sheets: Load more cover sheets according to section 2, "Making Booklets" and press the [Done] button. The message will extinguish and copier will start. 2. Using up the remaining cover sheets that are loaded: Press the [Dismiss] button. The message will extinguish and copier will start. <p> NOTE: <i>Be aware that if you use alternative 2, the system will hard stop i.e. without completing the cycle when there is no covers left.</i></p>
Load covers!	<p>Message is displayed when covers are empty. Message will also be displayed if the green [check] button was pressed after deciding to use Covers but before the bin was loaded.</p> <p>There are two ways to continue operation.</p> <ol style="list-style-type: none"> 1. If you wish to continue production: Load cover sheets according to section 2, "Making Booklets" and press the [Done] button. The message will extinguish and copier will start. 2. If cover job is finished and you wish to run a new job without covers: Select Cover Off in the Cover menu.

BookFold Module fault codes

BookFold Module

Code / message	Explanation / action
BF-001 - BF-151 Possible fault in area, please power off and power on to recover!	Indicates that there might be an internal communication error. Power off and on the system. If problem persists, contact customer support.
BF-201 - BF-206 Clear misfeed	<p>A misfeed has occurred in the BookFold Module. If problem persists, clean feed belts according to section 7, "REMARKS."</p> <p>Check that the pressure on the upper feed belts is set to the default position. The pressure springs should always be at its upper position where the pressure is equal to its highest value. See section 7, "REMARKS."</p>

Trimmer fault codes

Trimmer	
Code / message	Explanation / action
TR-001 - TR-153 Possible fault in area, please power off and power on to recover!	Indicates that there might be an internal communication error. Power off and on the system. If problem persists, contact customer support.
TR-201 - TR-206 Clear misfeed	A misfeed has occurred in the Trimmer. See section 5, "Clearing Misfeed(s)" for how to clear misfeed(s).
Empty trim waste bin from Face Trimmer!	Indicates that the trim bin is full or that a trim strip, due to static electricity, is prevented from falling down into the trim bin. Empty the trim bin and remove loose trim strips from inside the Trimmer. See section 1, "Basics." for how to remove the trim bin.
Close infeed belts!	Indicates that the infeed roller shaft assy. is lifted. Close it. See section 5, "Clearing Misfeed(s)."
Close exit belts!	Indicates that the exit compressing brackets are lifted. Close them. See section 5, "Clearing Misfeed(s)."
Close infeed and exit belts!	Indicates that the infeed roller shaft assy. and the exit compressing brackets are lifted. Close them. See section 5, "Clearing Misfeed(s)."

 **NOTE:**

During poor environmental conditions waste from the trimming operation may be transported through the system.

To improve the situation, the trim margin may be increased and thereby ensuring that the waste is transported into the waste bin.

Belt stacker fault codes

Belt stacker	
Code / message	Explanation / action
Stacker full, please empty stacker!	Stacker is full. Empty stacker.

General fault codes

Clear Misfeed(s)

Attention!



Paper misfeed detected at the following points, please clear the paper path.

Area B1: BM-202. Clear misfeed!

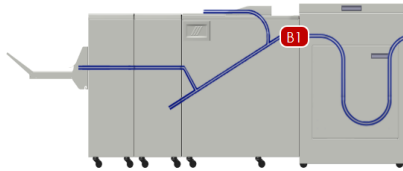

In general, fault codes indicate a misfeed condition. When a misfeed occurs, a code, the message “Clear misfeed(s)” and the jam area will be displayed. See section 5, “Clearing Misfeeds”, for how to clear a misfeed.

Close cover(s)

Close covers!

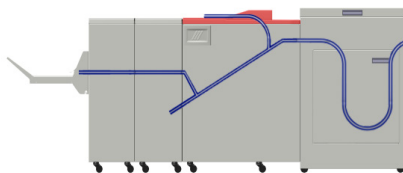

When the message “Close Cover(s)” is displayed any of the interlock switches are actuated.

- 1 Check that the top cover is in down position.
- 2 Make sure that the cover of the Belt Stacker is in normal position, see section 5, “Clearing Misfeeds”, Belt stacker.
- 3 Make sure power cables between Booklet Maker, BookFold and Trimmer are connected

Empty stacker!

Attention!

Area D: Stacker full, Please Empty stacker!

Done

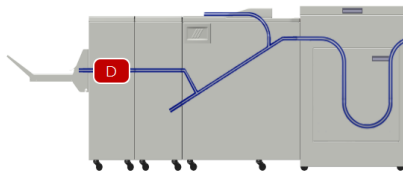

This message will be displayed when the stacker is full. Empty the belt stacker and press the [Done] button to continue operation.

7. REMARKS

Do's And Don'ts

- Always follow all warnings marked on, or supplied with, the equipment.
- Always exercise care in moving or relocating the equipment.
-  **CAUTION**
Unplug the power cord from the wall outlet and machine before you move or relocate the equipment.
- Do not remove the covers or guards that are fastened with screws.
- Do not override or bypass electrical or mechanical interlock devices.
- Do not operate the equipment if you notice unusual noises or odors. Disconnect the power cord from the power source and call your authorized technician to correct the problem.

 **WARNING**
Do not put fingers or other parts of the body between the upper and lower trimmer knives.

- Do not switch off the main power switch while machine is running. Make sure machine cycle has ended.
- Do not open covers while machine is running.
- Do not move machine while machine is running.

Where to put Your Machine

Machine environment

- **Always** locate the equipment on a solid support surface with adequate strength for the weight of the machine.
- Always keep magnets and all devices with strong magnetic fields away from the machine.

If the place of installation is air-conditioned or heated, do not place the machine where it will be:

- Subjected to sudden temperature changes.
- Directly exposed to cool air from air-conditioner.
- Directly exposed to heat from heater.
- Directly exposed to sunlight.

7

Power connection

- **Always** connect the equipment to a properly grounded power source. If in doubt, have the power source checked by a qualified electrician.
-  **WARNING**
Improper grounding of the equipment can result in electrical shock.
- **Never** connect the machine to a power source that lacks a ground connection terminal.

Access to machine

Place the machine near the power source, providing clearance as shown.

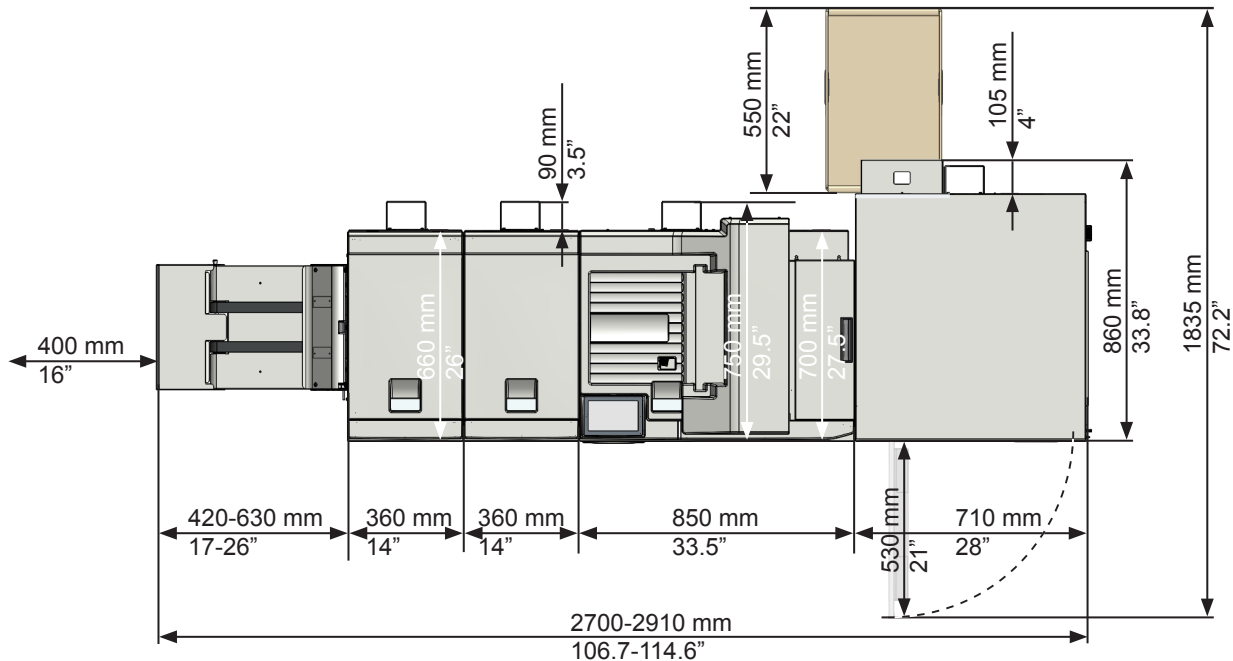

7

Ensure that the minimum required floor space is available for the system that you are about to install (Figure 1).

The optional high capacity Belt Stacker BST4000-1 can be placed either in-line or angled to the Booklet Making system. The BST4000-1 measures 1730x440 mm / 68x17".

Approximate floor space requirements / configuration;

- BLM 35/50 + Stacker ~1480 mm / 58.2".
- BLM 35/50 +FTR50 + Stacker ~ 1840 mm / 72.4".
- BLM 35/50 + BF50 + FTR50 + Stacker ~ 2200 mm / 86.6".
- RCT + BLM 35/50 + BF50 + FTR50 + Stacker = 2910 mm / 114.6".
- RCT + BLM 35/50 + BF50 + FTR50 + BST4000-1 Stacker (straight) = 4430 mm / 174.4".
- RCT + BLM 35/50 + BF50 + FTR50 + BST4000-1 Stacker (angled) = 3140 mm / 123.6".

NOTE:

BLM 35/50 Upgrade kit and Cover Feeder Module does not impact floor space requirements.

Maintaining Your Machines

Never attempt any maintenance function that is not specifically described in this documentation.

Cover Feeder

Cleaning feed rollers and paper separator pad

The Feed rollers need to be cleaned regularly when in use, and if the unit has not been used for a period of time. How often this should be done, depends on the paper type and print quality.

An increasing number of misfeeds, or double feeds, is one indication of the need to clean the Feed Rollers.

- 1** Remove the feed roller assembly by pressing it to the front of unit (A). The non operator side end of the feed roller assembly will now be released (B) and the assembly can be removed.
- 2** Clean the Feed rollers and the Paper separator pad with water and a clean lint free cloth.

7

Press toward front. Lift out this side Paper separator pad

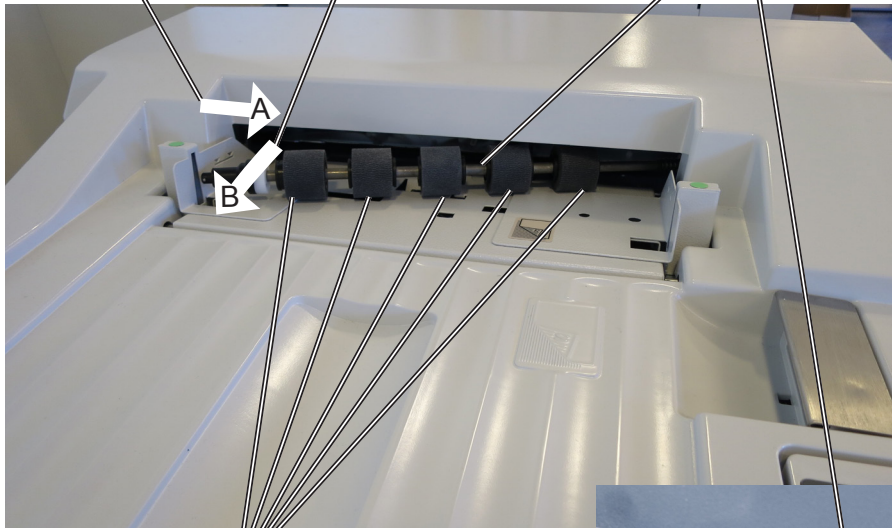

Feed rollers

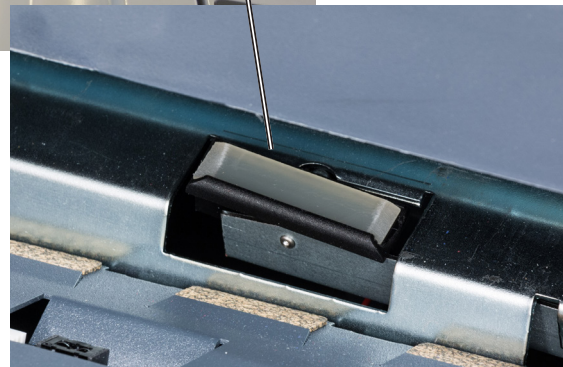

BookFold Module

Cleaning feed belts

The feed belts need to be cleaned regularly when in use, and if the unit has not been used for a period of time. How often this should be done, depends on the paper type and print quality.

An increasing number of misfeeds is one indication of the need to clean the feed belts. Clean the feed belts with water and a lint free cloth.

- 1** Open the top cover.
- 2** Clean the upper feed belts (A). The upper feed belts can easily be rotated in either direction.
- 3** Press the release latch (B), one to each and lift up the upper feed belts to access the lower feed belts.
- 4** Clean the lower feed belts (C). Rotate the lower feed belts towards the exit side for complete cleaning.
- 5** Place the upper feed belts in normal position.
- 6** Close the top cover.

7



Upper feed belts in normal position.

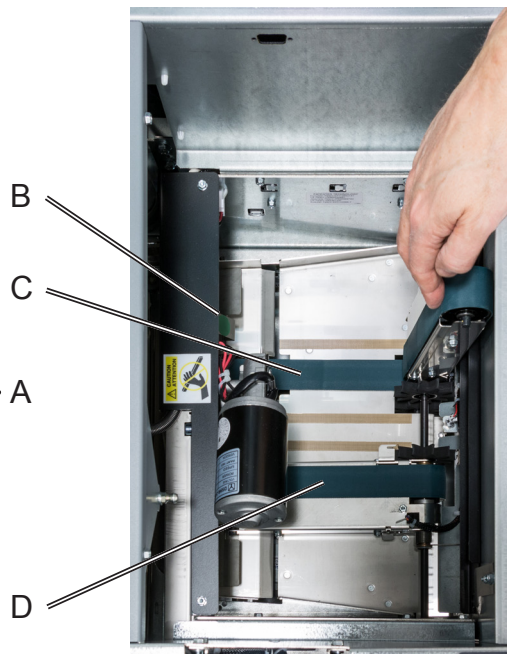

Upper non operator side feed belt lifted up.



NOTE:

The upper feed belt on the operator side (D) cannot be lifted fully.

BookFold Module, continued

Pressure springs

If feed errors occur, check that the pressure on the upper feed belts is set to the default position. The pressure springs should always be at its upper position where the pressure is equal to its highest value.

Non operator side spring in upper position (default position)



operator side spring in lower position

Pressure Clamps:

Smearing marks from the pressure clamps may appear if the clamps are not clean. If marks occur, run a number of blank booklets to clean the clamps prior to running your next set of booklets.

RCT Module

The feed rollers and paper path need to be cleaned regularly when in use, and if the unit has not been used for a period of time. How often this should be done depends on the paper type and print quality.

An increasing number of misfeeds is one indication of the need to clean the feed roller, paper path and/or the sensors. Feed rollers and paper path are cleaned with the same cleaning agent used to clean the printer and a lint free cloth. Sensors are wiped clean with a lint free cloth.

A problem with registration accuracy is often related to build up residual toner and paper dust.

⚠ CAUTION

Never use any cleaning fluids on sensors.

Cleaning the paper path transportation nip rollers (12x)

Also clean the idler rollers

⚠ WARNING

Do not put your fingers within knife protections.
Doing so may result in injury.

7

Knife protections

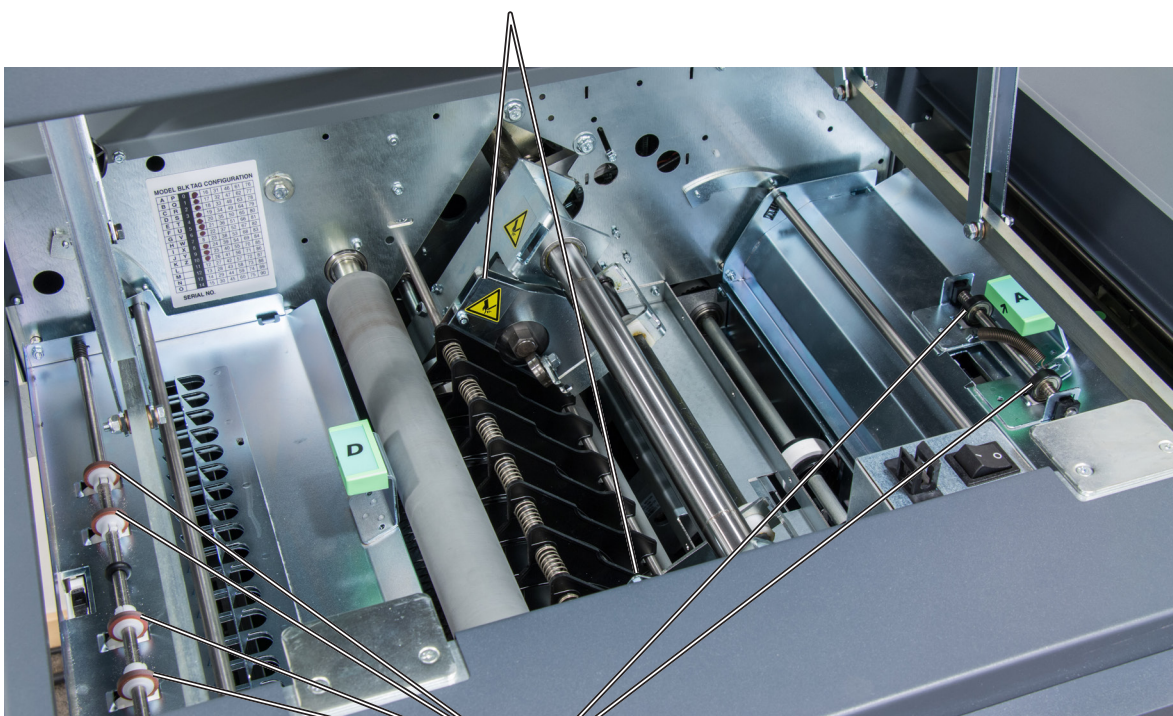

Nip rollers

Cleaning the paper path transportation nip rollers (12x), continued

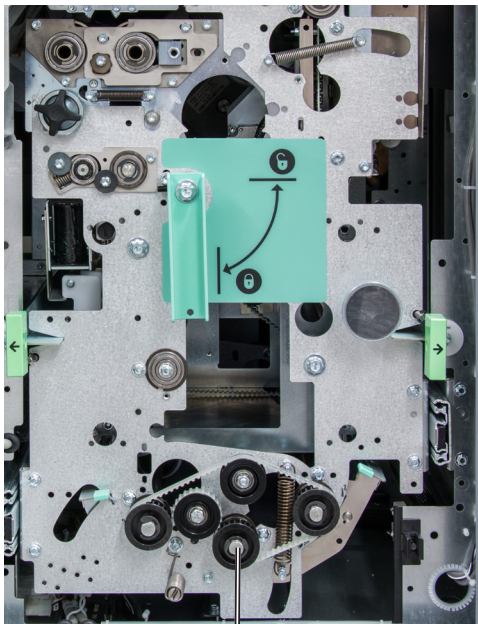

Nip rollers (2x)

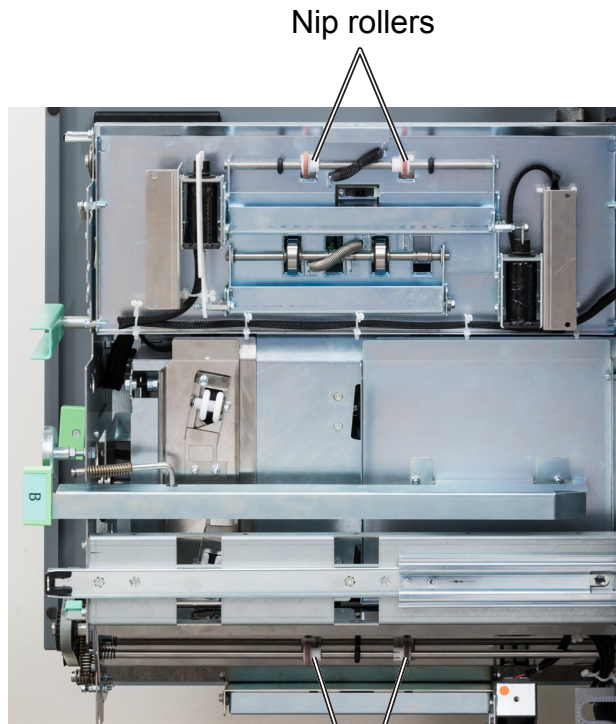

Nip rollers

Nip rollers

7

Cleaning the fixing rollers (3x)

Also clean the idling rollers

⚠ WARNING

**Do not place your fingers inside the knife guards.
Doing so may result in injury.**

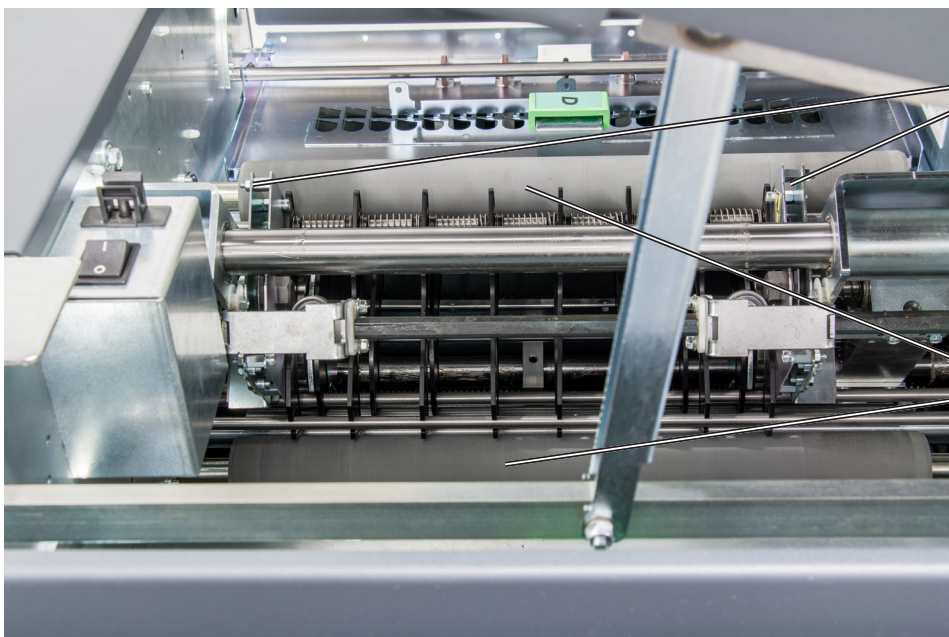

Knife guards

Fixing rollers

*continued on next
page*

Cleaning the fixing rollers (3x), continued

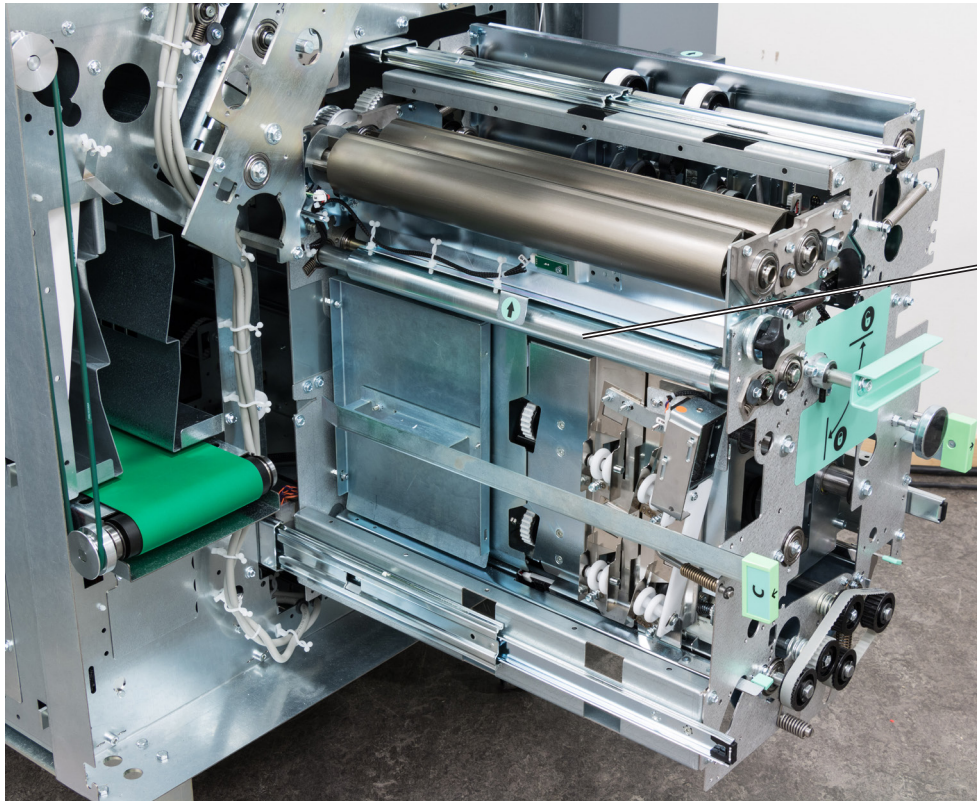

Fixing rollers

7

Cleaning the registration cross roller (4x) & friction tires (4X)

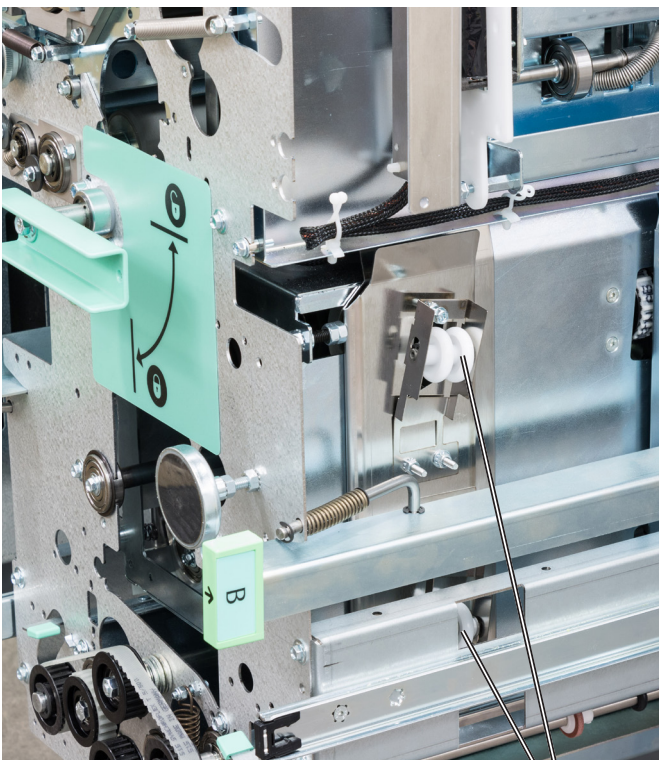

Registration cross rollers

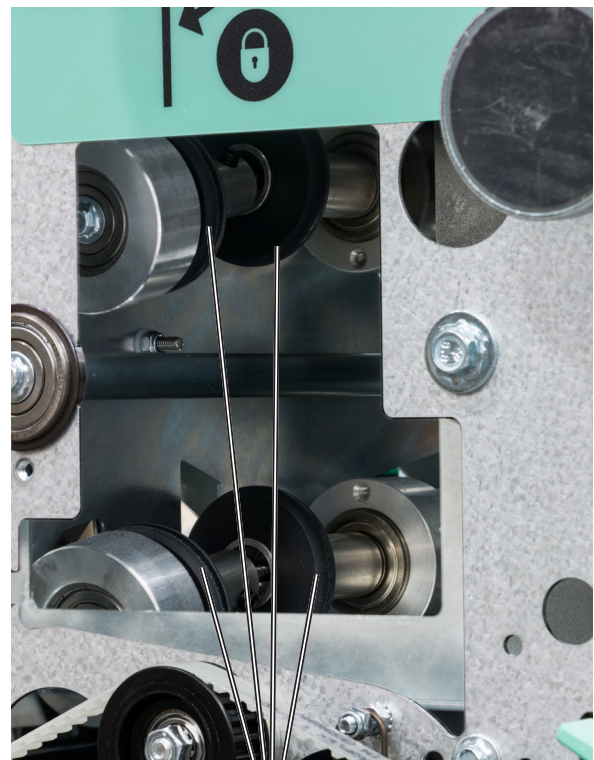

Cleaning friction tires

Cleaning the rotator rollers (2x)

Also clean the idler rollers



7

Cleaning the paper path sensors (5x)

⚠ WARNING
Do not place your fingers inside the knife guards.
Doing so may result in injury.

Infeed sensor

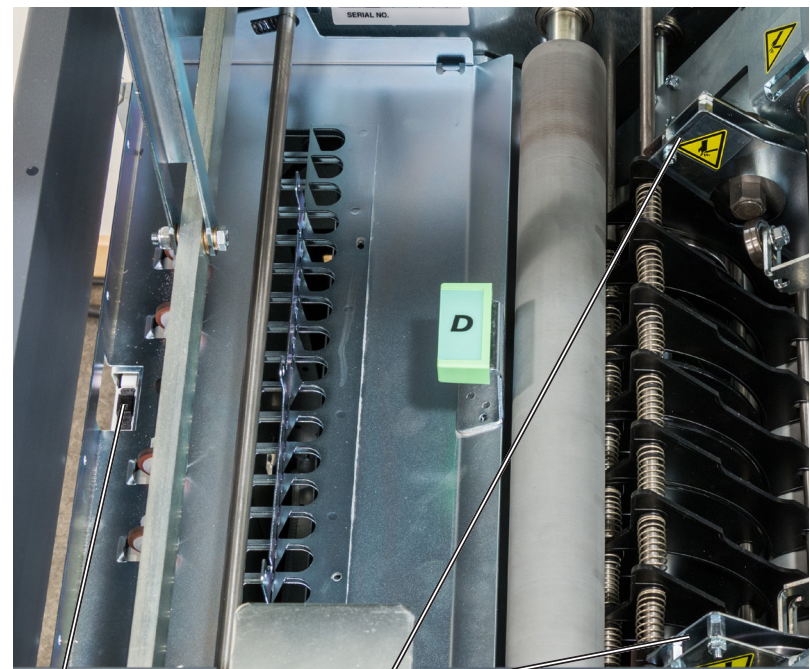
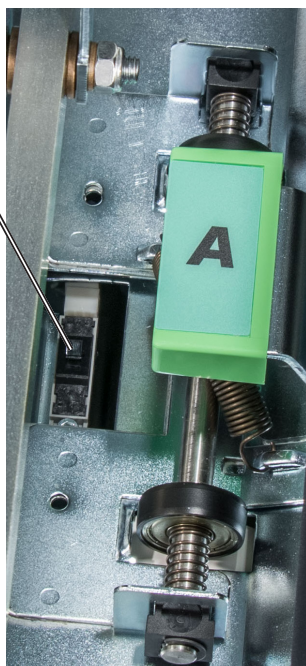

Exit sensor

Knife guards

continued on next page

Cleaning the paper path sensors (5x), continued

Rotator sensor

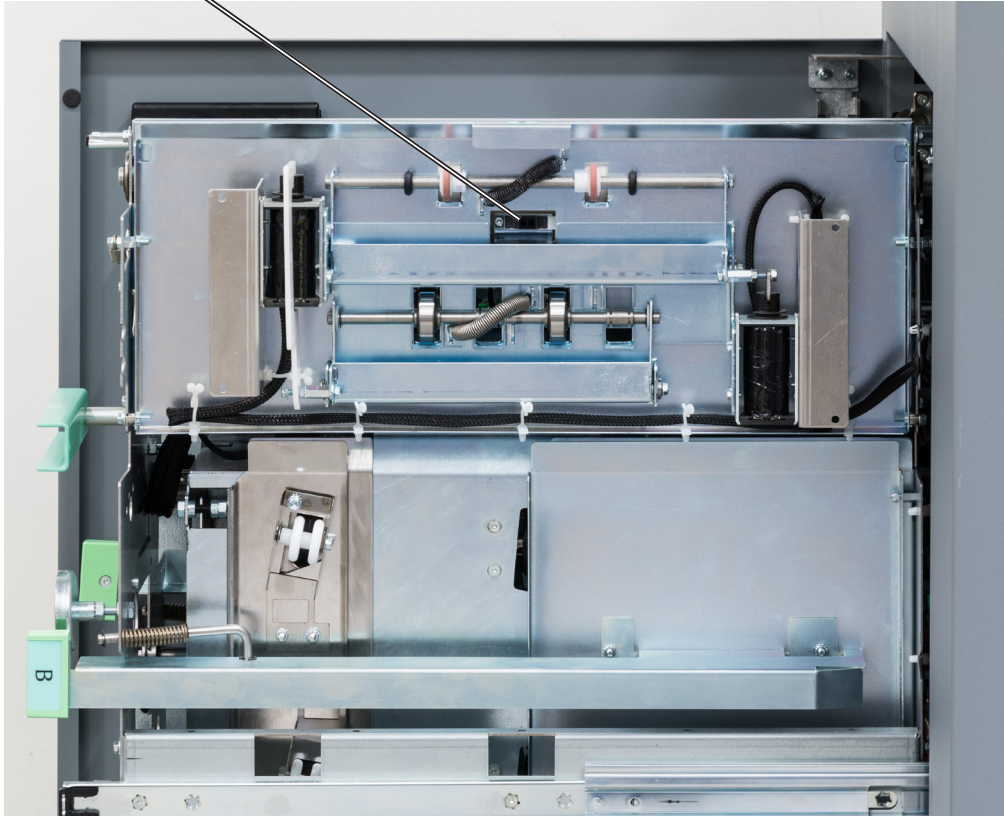

7



Registration sensor

Cleaning the paper path sensors (5x), continued

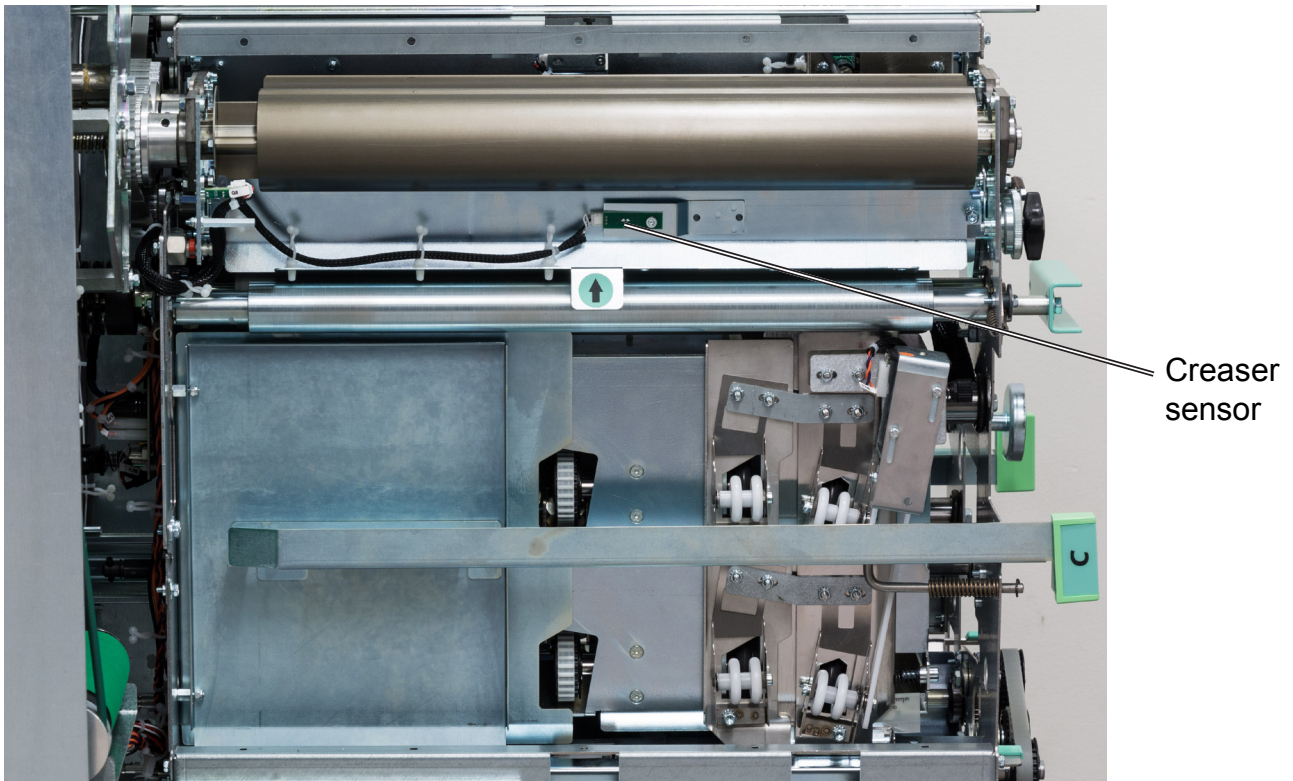

7

Cleaning of creaser tools (2x)

After a period of time toner and paper dust may leave residuals in the grooves of the tool. These grooves must be cleaned periodically to maintain creasing performance.

Grooves on both sides of the tool



Adjustment of Bleed Trimmer registration angle (parallel cut)

Adjustment of Bleed Trimmer registration angle (trimmer cut parallel to registration (operator side) edge)

- 1 Turn adjustment screw [A] in desired direction. Change in adjustment is reflected on the reference scale [B].

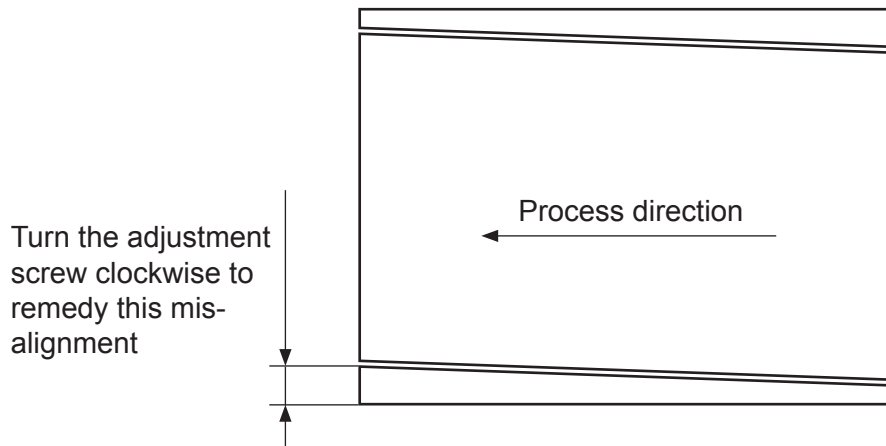

 **NOTE:**

Sheets may show wrinkles in the process direction if adjustment is set too tight. Turn adjustment screw counter clockwise until wrinkles disappear.

7



[A]

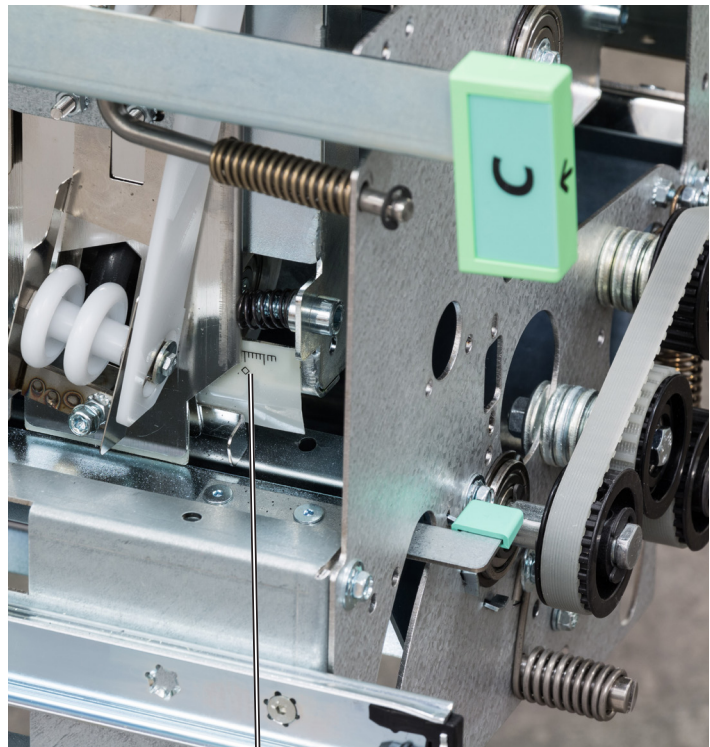

[B]

Adjustment of Creaser registration angle

Adjustment of Creaser registration angle

- 1 Loosen the star shaped knob [A].
- 2 Turn the knurled eccentric adjuster [B] to move reference mark in the desired direction.
- 3 Tighten the star shaped knob [A] again.

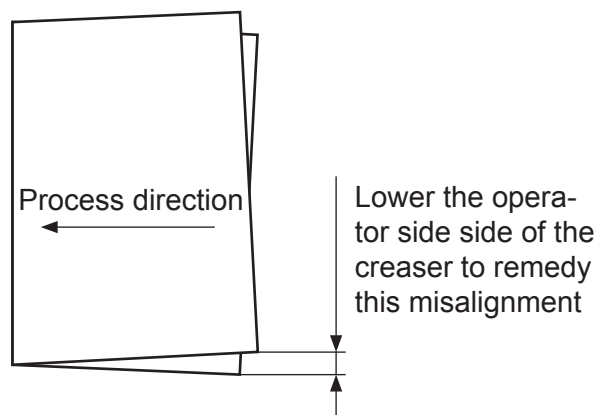

Reference marks

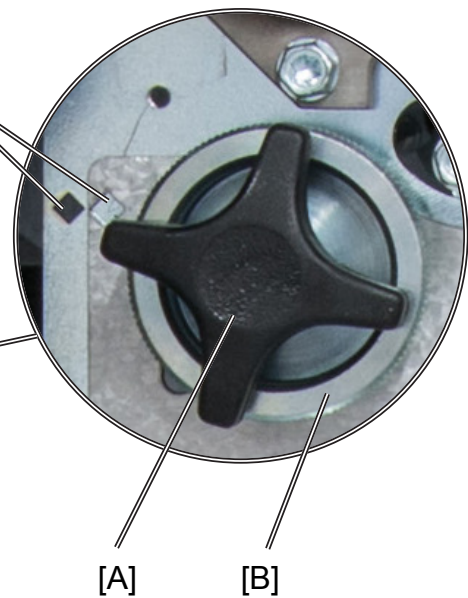
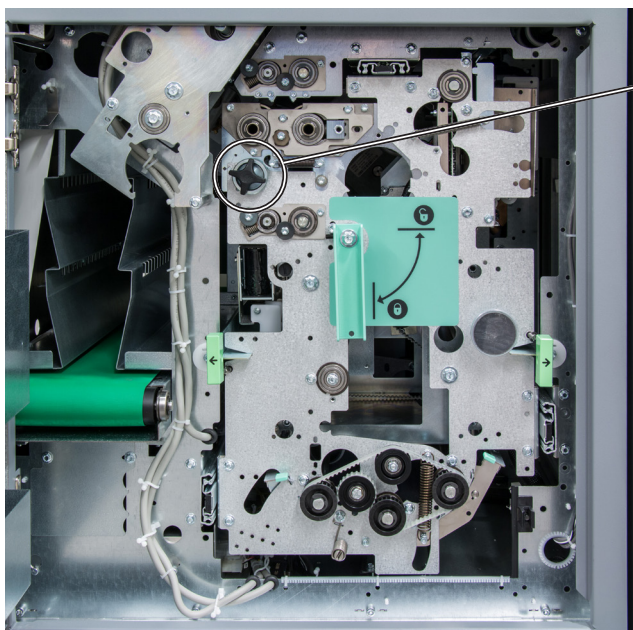

Best practices for the BLM 35/50 system

- If the set is not properly registered (side jogged and back jogged), fine adjustment of registration may improve the situation. See section Fine-tuning booklet appearance for details.
- If staples have problems penetrating thicker sets of heavy media changing staple cartridge may improve the situation.
- The BookFold Module may wrinkle the cover at the spine when light weight media is used for cover sheet. Changing to heavier stock or turning BookFold Module off usually resolves the problem.
- Staple back may be radius shaped (bent) when running with BookFold Module. Moving staple position so staple is centered on the spine will reduce this phenomenon.
- Covers may show marking along the spine of the booklet from the clamp in the BookFold Module. The more pages in the booklet, the more evident the marking.
- For jobs with multiple sheets of 200 gsm or heavier the BookFold Module is recommended for an acceptable output. If a BookFold Module is present in the configuration, it should be turned ON or feed problem at output may occur.
- If the Adjustment of “Bleed Trimmer registration angle” described in section Maintaining Your Machines in the OP manual is set too tight, the sheets may show wrinkles in the process direction.
 - To prevent this phenomenon, turn the adjustment screw counter clockwise until the wrinkles disappear.
- If a JOB is cancelled on the printer there might be an incomplete set inside the BLM 35/50 system. This set has to be manually removed from the system by opening and closing the top cover of the Booklet Maker. This will purge the set.

Limitations of the BLM 35/50 system

- The BLM 35/50 Production Booklet Maker systems are suited for customers whose booklet making needs will not exceed a yearly average of 30,000 booklets per month.
- If sheets entering the BLM 35/50 is not uniform and square the booklet quality will vary accordingly.
- The maximum recommended number of sheets that can be folded without stapling is 5 sheets of 80 gsm. If there is very low friction between the sheets, running non stapled sets may be difficult.
- Staple position may vary on the spine when being square formed with the BookFold Module, especially on thicker booklets. Moving staple position so staple is centered on the spine will reduce this phenomenon.
- Staple may be radius shaped (bent) when running with the BookFold Module. Moving staple position so staple is centered on the spine will reduce this phenomenon.
- Covers may show marking along the spine of the booklet from the clamp in the BookFold Module. The more pages in the booklet, the more evident the marking.
- For some white coated stock, such as “Silk type” two sided coated paper, occasional fold roller marks may be observed on the “top side” of the book.
- The double feed sensor should be turned off when feeding cover 200 gsm or more from the Cover Feeder. You may also have to turn off this function if you have heavy dark area coverage or covers with different images on them.
- For jobs with multiple sheets of 200 gsm or heavier, the BookFold Module is recommended for an acceptable output. If a BookFold Module is present in the configuration it shall be turned ON or feed problem at output may occur.
- Heavy weight media will show image crack in the spine, pre-crease the cover to avoid cracking.
- Thick books made from coated stock with high friction between each sheet may show permanent “wave like” deformation of the sheets.
- Marks from the fold knife may appear on sensitive media on the inner sheet.
- Marks from side guide motion may appear on sensitive media.
- Never run simplex printed sheets from the printer in-line.
- Covers may show markings from the Cover Feeder separation process.
- Avoid using smear sensitive material in Cover Feeder.
- Small booklets A5/ 5,5 x 8,5” or smaller may stack poorly on the conveyer.
- If corners/edges of sheets by any reason are folded before trimming, result may look as illustrated when corners/edges are unfolded.

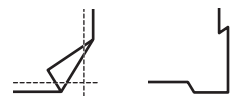

Limitations of the BLM 35/50 system, cont.

- Sheets may show marks from the “registration rollers” in the RCT module, as shown in the image below. These marks are more commonly seen on silk/coated paper and on darker images. Changing media will improve the situation.



These marks have been seen consistently on the following media:

- Océ Top Coated Plus Silk
 - Océ Top Coated Plus Gloss
 - Océ Top Colour Zero
 - Neenah Smooth
- On some coated media, staples may not completely penetrate the set resulting in a faulty staple. If problem persists, consider changing media. Staple may not be able to penetrate the number of sheets indicated by the “Set Size Guide”. Some uncoated extra “dense” paper may show the same limitation. The following list shows examples of media where this has been observed:
 - Futura Laser Gloss 80c
 - Hammermil Laser Print
 - OPUS Gloss
 - On brand new Booklet Maker units, paper may show trace of oil coming from the fold mechanism. Oil is applied to the mechanism during production. The problem will be eliminated after initial production.
 - When trimming small amount (less than 5mm or 0.2”) in the Trimmer Module on books made from more than 2 sheets, the cut may not be clean, leaving trim waste hanging from the book.
 - Paper can show markings on the lead edge of the set from the compiler area. If this occurs the use of the Trimmer Module will eliminate this
 - For thick booklets, the clinch quality of the staples may show limitations resulting in the staple legs to be spaced away from the sheets.
 - Heavy media above 250gsm/14lb Index may show feeding problems in the RCT Module. This issue will be more common on smaller sheet sizes A4 and 8,5” x 11”

Limitations of the BLM 35/50 system, cont.

- Staple leg offset outside the 1,0mm specification can occur on thicker sets. To check if the unit performs within specification produce a book made from 4 sheets of 80 gsm plain paper.

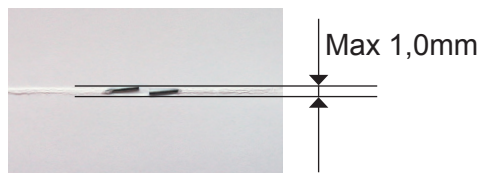

- For thick books with a thin cover, the cover can be “pulled back” during the registration process in the Face Trimmer. This can result in the cover sheet not being trimmed. Recommendation is to use a heavier cover for thick books (over approx. 15 sheets).
- For some media, the legs of the staples may not be properly clinched causing the legs of the staple to be spaced away from the inner sheet. This phenomenon occurs on extra thick books over 40 sheets made from “soft” paper (recycled and some non-coated media mostly).
- The BookFold roller can pick up “colour” from the first staple during the BookFold process. After one full revolution of the BookFold roller, the colour is smeared off on the spine of the booklet. This phenomenon occurs more for some coated media and for higher BookFold modes.
- The “pressure foot” in the BookFold Module can cause a shiny mark on sensitive media. This phenomenon has been observed on Glossy media.
- Thick booklets that are not square folded may have a higher tendency to be scratched.
- Sensitive media may pick up toner or residue while being transported through the paper path. Cleaning the paper path and conducting some preventative maintenance may help improve the situation.

8. Specification

Machine Specifications

Rotate Crease Trim Module (option)

	Specifications	Remarks
Speed	Same as BLM35/50 Booklet Maker	
Standard Paper Sizes	Same as BLM35/50 Booklet Maker	
Paper Size Minimum (Out)	Same as BLM35/50 Booklet Maker	
Paper Size Maximum (Out)	Same as BLM35/50 Booklet Maker	
Paper Width Maximum (In)	330mm	5mm bleed trim will automatically be turned on
Paper Weight (Minimum)	Same as BLM35/50 Booklet Maker	
Paper Weight (Maximum)	Same as BLM35/50 Booklet Maker	Above 300gsm limited performance with some media
Rotator (optional) Rotation is only possible within the interval	Width (cross process direction) min. 275mm. (10.9"). Width (cross process direction) max. 325mm. (12.7"). Length (process direction) min. 205mm. (8.1"). Length (process direction) max. 232mm. (9.1").	
Creaser Tools Fine tool Coarse tool	Stock < 120 gsm Stock > 120 gsm (gsm =grams per sq. meter)	
Bleed Trimmer Minimum bleed trimming Maximum bleed trimming Max asymmetric bleed trimming	5 mm 30 mm ±5 mm	On each side of the sheet
Input / Output Sheets	Same as BLM35/50 Booklet Maker	
Input / Output Sheets	Same as BLM35/50 Booklet Maker	
Off-line Use	Not possible	
Weight	210kg/463lb	
Dimensions (W x D x H)	710 x 860 x 1080 / 28 x 33.8 x 42.5" (incl. 105mm / 4" waste transport)	
Power Source	100 - 230V ±10% 50-60Hz	
Power Consumption	300W	Continuous operation
	400W	Max

Booklet Maker

Major Specifications

	Specifications	Remarks
Speed (Online usage)	Maintains engine speed.	Actual speed in number of booklets (per min / hour) depends on number of sheets per booklet.
Standard Paper Sizes	A4, SRA4, B4, A3, SRA3, 8.5x11", 8.5x14", 9x12", 11x17", 12x18"	Custom sizes are available
Paper Size (Minimum)	Width 206mm / 8.1" Length 275mm / 10.8"	
Paper Size (Maximum)	Width 320mm / 12.6" Length 457.2mm / 18"	
Paper Weight (Minimum)	64gsm/16lb Bond uncoated 105gsm coated	
Paper Weight (Maximum)	300gsm / 172lb Index / 115lb Cover	350gsm / 130lb Cover
Belt stacker capacity	2 sheets: 200 sets 8 sheets: 70 sets 15 sheets: 35 sets 20 sheets: 25 sets 30 sheets: 15 sets 35 sheets: 15 sets 40 sheets: 10 sets 45 sheets: 10 sets 50 sheets: 10 sets	80gsm / 20lb Bond Figures are based on rough estimates and founded on pure observation
Folding/stapling capability	2 – 35 or 50 Sheets (80gsm / 20lb Bond)	See Set Size Guide for more information
Folding capability only	1 to 2 sheets	
Off-line use	Possible	Staple / Fold (2 staples)
Weight	155 kg / 341.7 lb	
Dimensions (W x D x H)	1420 x 730 x 1050mm / 55.9 x 28.8 x 41.4"	Incl. belt stacker* Incl. cable protector**
Power Source	100 - 230V, 50-60Hz	+ 6%, - 10%
Power consumption	250 or less	Continuous Operations
Noise emission	62dB	Complete system

Plockmatic use open source code in parts of this product

*The Belt Stacker, installed after Booklet Maker, BookFold Module or Trimmer, adds 420 - 630mm / 16.5" - 24.8" to system length.

**Cable protector adds 50mm / 2" to depth.

Cover Feeder Module

	Specifications	Remarks
Maximum Speed	Same as BLM35/50 Booklet Maker	A3/11x17" or bigger paper sizes, need two sheet sets as inlet at least
Standard Paper Sizes	Same as BLM35/50 Booklet Maker	
Paper Weight (Minimum)	64gsm / 16lb Bond	
Paper Weight (Maximum)	250gsm / 67lb Bond	
Cover Feeder Capacity	20mm (app. 200 sheets of 80gsm paper) 13/16" (app. 200 sheets of 20lb Bond paper)	
Off-line Use	Possible	(Together with Booklet maker)
Weight	8kg / 17.6lb or less	
Dimensions (W x D x H)	310 x 190 x 530mm / 12.2 x 7.5 x 20.9"	The Cover Feeder dimensions are included in the Booklet Maker dimensions and will not add anything more to the space.
Power Source	From BLM35/50 Booklet Maker	

Trimmer Module

	Specifications	Remarks
Speed	1800 sets per hour	
Standard Paper Sizes	Same as BLM35/50 Booklet Maker	Custom sizes are available
Default trim length	4.5mm / (11/64")	Adjustable in 0.5mm (0.004") steps
Minimum trimming	1mm / (0.0394")*	Rec. min trim is 2,5mm (0.098")
Maximum trimming	16mm ($\frac{5}{8}$ ") per cut	Possible to trim down to 105mm ($\frac{49}{64}$ "). Trim larger than 16mm ($\frac{5}{8}$ ") will cause trimmer to make multiple cycles. This reduces system speed in some applications. Multiple cuts also affect lifetime.
Paper Weight (Min / Max)	Same as BLM35/50 Booklet Maker	
Paper Weight (Max)	Same as BLM35/50 Booklet Maker	
Input / Output Sheets	Same as BLM35/50 Booklet Maker	
Off-line Use	Possible	(Together with Booklet maker)
Weight	73kg / 160.8lb or less	
Dimensions (W x D x H)	360 x 1100 x 730mm / 14.2 x 43.3 x 28.8"	Incl. cable protector**
Power Source	From BLM35/50 Booklet Maker	

* When trimming SRA3 (450mm) Booklets minimum trimming is 5mm, when trimming 18" Booklets minimum trimming is 9mm / 0.35".

**Cable protector adds 90mm / 3.5" to depth.

BookFold Module

	Specifications	Remarks
Speed	Same as BLM35/50 Booklet Maker	Appr. 6 - 30 sheet booklet (80gsm / 20lb Bond)
Standard Paper Sizes	Same as BLM35/50 Booklet Maker	Custom sizes are available
Paper Weight (Minimum)	Same as BLM35/50 Booklet Maker	
Paper Weight (Maximum)	Same as BLM35/50 Booklet Maker	
Input / Output Sheets	Same as BLM35/50 Booklet Maker	
Off-line Use	Possible	(Together with Booklet maker & Trimmer)
Weight	53kg / 116.7lb	
Dimensions (W x H x D)	360 x 1100 x 730mm / 14.2 x 43.3 x 28.8"	Incl. cable protector*
Power Source	From BLM35/50 Booklet Maker	

*Cable protector adds 90mm / 3.5" to depth.

BST4000-1 Belt Stacker Module

8

	Specifications	Remarks
Speed	Variable	
Overlap	Adjustable	
Capacity	A4 / 8,3"x11,7"≥ 1,000 A3 / 11,7"x16,5"≥ 500	Booklet of 2 sheets 80gsm / 20lb Bond Booklet of 2 sheets 80gsm / 20lb Bond
Side guides	Adjustable 0-357mm / 14"	
Weight	70kg/1541lb	
Dimensions Table height Width Length	575 - 1000mm / 22.6" - 39.4" 440mm / 17" 1380mm / 54"	Input height = Table height + 60mm / 2.4" + Control unit + 350mm / 14" for end stacking tray
Power Source	100 - 240V, 50-60Hz, 1A	+ 6%, - 10%
Power Consumption	70W or less	

System Set Size Guide

 **NOTE:**

The following tables are guidelines designed to give an indication of how many sheets a specific application can have at a given media weight.

On some coated media staples may not penetrate the set resulting in a faulty staple. If problem persists, consider changing media. Staple may not be able to penetrate the number of sheets indicated by the "Set Size Guide". Some uncoated extra "dense" paper may show the same limitation. The following media are examples of this:

Futura Laser Gloss 80c

Hammermil Laser Print

OPUS Gloss

Exact number of sheets is depending on media type and area coverage.

Paper weight						BLM50				BLM35			
						Paper Size				Paper Size			
						A3 or 11x17"		A4 or 8.5x11"		A3 or 11 x 17"		A4 or 8,5 x 11"	
						Area Coverage		Area Coverage		Area Coverage		Area Coverage	
						Low	Full	Low	Full	Low	Full	Low	Full
Bond	Offset	Cover	Tag	Index	Gsm	50	32	50	32	35	25	35	25
20	50	28	46	42	80	45	32	44	32	30	20	30	20
24	60	33	56	50	90	25	24	26	25	22	19	22	19
31	81	45	73	66	120	20	19	22	20	17	15	20	15
36	90	50	82	75	140	15	14	15	15	13	10	13	10
53	135	74	122	110	200	13	12	14	12	11	9	11	9
58	146	80	134	120	220	12	10	10	10	9	7	9	7
76	192	105	175	158	280	9	9	9	9	8	6	8	6
82	208	114	189	170	300								

 **NOTE:**

1. For cover jobs , deduct 2 sheets
2. Paper size: large = A3/11x17"> , Small = <A3/11x17"
3. Area coverage: Low = text only, High = Pictures, Full = Maximum coverage
4. For jobs with multiple sheets of 200 gsm or higher paper weight the BookFold Module is recommended for an acceptable output

EU DECLARATION OF CONFORMITY ^[1]

No. ^[2] **N0004233 (A.2)**

Manufacturer ^[3] Plockmatic International AB, Telefonvägen 30, S-126 26 Hågersten, Sweden

This Declaration of Conformity is issued under the sole responsibility of the manufacturer ^[4]

Object of the Declaration ^[5]				
Type/Model ^[6]	F102-012	F103-012	F104-004	F105-012
Name ^[7]	BLM35 BLM50	FTR50	CF50	BF50
Description ^[8]	Booklet Maker	Trimmer	Cover Feeder	BookFold

The object of the declaration is in conformity with the relevant Union harmonization legislation: ^[9]	
Directive ^[10]	Standard ^[11]
2004/108/EC (EMC)	EN 55022:2010 (Class A), EN 55024:2010 EN 61000-3-2:2014, EN 61000-3-3:2013 EN 62311:2008
2011/65/EU (RoHS)	EN 50581:2012 EN 62321:2009
2014/35/EU (LVD)	EN 60950-1:2006 + A1:2010 + A2:2013 + A11:2009 + A12:2011
Additional information ^[12] International certification: UL 60950-1, 2nd Edition, 2014-10-14, CAN/CSA C22.2 No. 60950-1-07, 2nd Edition, 2014-10, IEC 60950-1:2005 (2nd Edition); Am 1:2009, FCC Part 15 (2012) Subpart B, Class B, ICES-003 Issue 5 Class B	
Signed for and on behalf of ^[13] Hågersten, 2016-08-17 16:42	
 Bengt Olenfalk Group Quality Manager	

БЪЛГАРСКИ: 1) ЕС Декларация за съответствие; 2) Номер; 3) Производител; 4) Настоящата декларация за съответствие е издадена на отговорността на производителя; 5) Предмет на декларацията; 6) Модел/Тип; 7) Назначение; 8) Описание; 9) Предметът на декларацията, описан по-горе, отговаря на съответното законодателство на Съюза за хармонизация; 10) Директива; 11) Стандарт; 12) Допълнителна информация; 13) Подписано за и от името на

ČESKÝ: 1) EU Prohlášení o shodě; 2) Číslo; 3) Výrobce; 4) Toto prohlášení o shodě se vydává na výhradní odpovědnost výrobce; 5) Předmět prohlášení; 6) Model/Typ; 7) Označení; 8) Popis; 9) Výše popsaný předmět prohlášení je ve shodě s příslušnými harmonizačními právními předpisy Unie; 10) Směrnice; 11) Norma; 12) Dodatečné informace; 13) Podepsáno za a jménem na

DANSK: 1) EU-Overensstemmelseserklæring; 2) Nummer; 3) Producent; 4) Denne overensstemmelseserklæring udstedes på fabrikantens ansvar; 5) Erklæringens genstand; 6) Model/Type; 7) Betegnelse; 8) Beskrivelse; 9) Genstanden for erklæringen, som beskrevet ovenfor, er i overensstemmelse med den relevante EU-harmoniseringslovgivning; 10) Direktiv; 11) Standard; 12) Yderligere information; 13) Underskrevet for og vegne

DEUTSCH: 1) EU-Konformitätserklärung; 2) Nummer; 3) Hersteller; 4) Die alleinige Verantwortung für die Ausstellung dieser Konformitätserklärung trägt der Hersteller; 5) Gegenstand der Erklärung; 6) Modell/Typ; 7) Bezeichnung; 8) Beschreibung; 9) Der oben beschriebene Gegenstand der Erklärung erfüllt die einschlägigen Harmonisierungsrechtsvorschriften der Union; 10) Direktive; 11) Standard; 12) Weitere Informationen; 13) Zur Unterzeichnung und Namen

EESTI: 1) ELi Vastavusdeklaratsioon; 2) Number; 3) Valmistaja; 4) Käesolev vastavusdeklaratsioon on välja antud tootja ainuvastutusele; 5) Deklareeritav; 6) Model/Type; 7) Nimetus; 8) Kirjeldus; 9) Eelkirjelatud deklareeritav toode on kooskõlas asjaomaste liidu ühtlustamisaktidega; 10) Direktiiv; 11) Standard; 12) Lisainfo; 13) Allkirjastatud ja nimel

SUOMI: 1) EU-Vaatimustenmukaisuusvakuutus; 2) Määrä; 3) Valmistaja; 4) Tämä vaatimustenmukaisuusvakuutus on annettu valmistajan yksinomaisella vastuulla; 5) Vakuutuksen kohde; 6) Malli/Typppi; 7) Nimitys; 8) Kuvaus; 9) Edellä kuvattu vakuutuksen kohde on asiaa koskevan unionin yhdenmukaistamislainsäädännön vaatimusten mukainen; 10) Direktiivi; 11) Standardi; 12) Lisäinformaatio; 13) Allekirjoitettu ja puolesta

FRANÇAIS: 1) Déclaration UE de conformité; 2) Nombre; 3) Fabricant; 4) La présente déclaration de conformité est établie sous la seule responsabilité du fabricant; 5) Objet de la déclaration; 6) Modèle/type; 7) Désignation; 8) Description; 9) L'objet de la déclaration décrit ci-dessus est conforme à la législation d'harmonisation de l'Union applicable; 10) Directif; 11) Standard; 12) Information Supplémentaire; 13) Signé pour et au nom de

GAEILGE: 1) Dearbhú comhréireachta AE; 2) Uimhir; 3) Manufacturer; 4) Tá an dearbhú comhréireachta ama eisiúint faoi fhreagracht an mhonaraí; 5) Cuspóir an dearbhairthe; 6) Cineál; 7) Ainmniú; 8) Tuairisc; 9) Is é cuspóir an dearbhairthe a thabairt i gcomhréir leis an reachtaíocht chomhchuíbhíthe ábhartha an Aontais; 10) Treoir; 11) Caighdeánach; 12) Eolas breise; 13) Ama shíniú le haghaidh agus thar ceann an

ΕΛΛΗΝΙΚΗ: 1) Δήλωση συμμόρφωσης ΕΕ; 2) αριθμός; 3) Κατασκευαστής; 4) Η παρούσα δήλωση συμμόρφωσης εκδίδεται με αποκλειστική ευθύνη του κατασκευαστή; 5) Αντικείμενο της δήλωσης; 6) Μοντέλο/Τύπος; 7) Ονομασία; 8) Περιγραφή; 9) Ο στόχος της δήλωσης που περιγράφεται παραπάνω είναι σύμφωνος με τη σχετική ενοωσιακή νομοθεσία εναρμόνισης; 10) Διευθυντικός; 11) Πρότυπο; 12) Επιπλέον πληροφορίες; 13) Υπογραφή για λογαριασμό και εξ ονόματος του

HRVATSKI: 1) EU Izjava o sukladnosti; 2) Broj; 3) Proizvođač; 4) Za izdavanje EU izjave o sukladnosti odgovoran je isključivo proizvođač; 5) Predmet deklaracije; 6) Model/Tip; 7) Oznaka; 8) Deskripcija; 9) Predmet navedene izjave u skladu je s mjerodavnim zakonodavstvom Unije o usklađivanju; 10) Direktiva; 11) Standard; 12) Dodatne informacije; 13) Potpisao za i u ime

MAGYAR: 1) EU-Megfelelőségi nyilatkozat; 2) Szám; 3) Gyártó; 4) Ezt a megfeleléségi nyilatkozatot a gyártó kizárólagos felelőssége mellett adja ki; 5) A nyilatkozat tárgya; 6) Modell/Típus; 7) Kijelölés; 8) Leírás; 9) A fent ismertetett nyilatkozat tárgya megfelel a vonatkozó uniós harmonizációs jogszabályoknak; 10) Irányelv; 11) Standard; 12) További információ; 13) Aláírva nevében

ISLENSKA: 1) ESB Leyfisfyrirlysing; 2) Fjöldi; 3) Framleiðandi; 4) Þessi samræmisfyrirlysing er sett alfrán á ábyrgð framleiðanda; 5) Markmið fyrirlýsingarinnar; 6) Gerð; 7) Tilnefning; 8) Lýsing; 9) Markmið fyrirlýsingarinnar lýst er hér að ofan er í samræmi við viðeigandi Unions samræfningu löggjafar; 10) Tilskipun; 11) Standard; 12) Viðbótarupplýsingar; 13) Undirritað fyrir og fyrir hönd

ITALIANO: 1) Dichiarazione di conformità UE; 2) Numero; 3) Produttore; 4) La presente dichiarazione di conformità è rilasciata sotto la responsabilità esclusiva del fabbricante; 5) Oggetto della dichiarazione; 6) Modello/Tip; 7) Designazione; 8) Descrizione; 9) L'oggetto della dichiarazione di cui sopra è conforme alla pertinente normativa di armonizzazione dell'Unione; 10) Direttiva; 11) Standard; 12) Informazioni aggiuntive; 13) Firmato e per conto di

LATVIEŠU: 1) ES Atbilstības deklarācija; 2) Numurs; 3) Ražotājs; 4) Šī atbilstības deklarācija ir izdota vienīgi uz ražotāja atbildību; 5) Deklarācijas priekšmets; 6) Modeļa/tipa; 7) Apzīmējums; 8) Apraksts; 9) Iepriekš aprakstītais deklarācijas priekšmets atbilst attiecīgajam Savienības saskaņošanas tiesību aktam; 10) Direktīva; 11) Standarts; 12) Papildoma informācija; 13) Parakstīts vārdā

LIETUVIŲ: 1) ES Atitikties deklaracija; 2) Skaicius; 3) Gamintojas; 4) Ši atitikties deklaracija išduota tik gamintojo atsakomybe; 5) Deklaracijos objektas; 6) Modelis/tipas; 7) Pavadinimas; 8) Aprašymas; 9) Pirmaia aprašytas deklaracijos objektas atitinka susijusius derinamuosius Sąjungos teisės aktus; 10) Direktyva; 11) Standartinė; 12) Papildoma informacija; 13) Pasirašyta ir vardu

MALTESE: 1) Dikjarazzjoni ta' konformità tal-UE; 2) Numru; 3) Manifattur; 4) Din id-dikjarazzjoni ta' konformità tinhareg taht ir-responsabbiltà unika tal-manifattur; 5) Għan tad-dikjarazzjoni; 6) Mudell/Tip; 7) Deżinjazzjoni; 8) Deskrizzjoni; 9) L-għan tad-dikjarazzjoni deskritt hawn fuq huwa konformi mal-legislazzjoni ta' armonizzazzjoni rilevanti tal-Unjoni; 10) Direttiva; 11) Standard; 12) Informazzjoni addizzjonali; 13) Iffirmat għal u fisem il

NEDERLANDS: 1) EU-Conformiteitsverklaring; 2) Nummer; 3) Fabrikant; 4) Deze conformiteitsverklaring wordt verstrekt onder volledige verantwoordelijkheid van de fabrikant; 5) Voorwerp van de verklaring; 6) Model/Type; 7) Benaming; 8) Beschrijving; 9) Het hierboven beschreven voorwerp is in overeenstemming met de desbetreffende harmonisatiewetgeving van de Unie; 10) Richtlijn; 11) Standaard; 12) Aanvullende informatie; 13) Ondertekend voor en namens

NORSK: 1) EU-Erklæring; 2) Nummer; 3) Producent; 4) Denne samsvarserklæringen er utstedt under ansvar av produsenten; 5) Formålet med erklæringen; 6) Type; 7) Betegnelse; 8) Beskrivelse; 9) Formålet med erklæringen som er beskrevet ovenfor er i samsvar med relevante Union harmoniseringslovgivning; 10) Direktiv; 11) Standard; 12) Ytterligere informasjon; 13) Signert for og vegne av

POLSKI: 1) Deklaracja zgodności UE; 2) Numer; 3) Producent; 4) Niniejsza deklaracja zgodności wydana zostaje na wyłączną odpowiedzialność producenta; 5) Przedmiot deklaracji; 6) Model/Typ; 7) Oznaczenie; 8) Opis; 9) Wymieniony powyżej przedmiot niniejszej deklaracji jest zgodny z odpowiednimi wymaganiami unijnego prawodawstwa harmonizacyjnego; 10) Dyrektywa; 11) Standard; 12) Dodatkowe informacje; 13) Podpisano imieniem

PORTUGUÊS: 1) Declaração UE de conformidade; 2) Número; 3) Fabricante; 4) A presente declaração de conformidade é emitida sob a exclusiva responsabilidade do fabricante; 5) Objeto da declaração; 6) Modelo/Tip; 7) A denominação; 8) Descrição; 9) O objeto da declaração acima descrito está em conformidade com a legislação de harmonização da União aplicável; 10) Diretiva; 11) Padrão; 12) Informações adicionais; 13) Assinado por e nome

ROMÂNĂ: 1) Declarația UE de conformitate; 2) Număr; 3) Producător; 4) Prezenta declarație de conformitate este emisă pe răspunderea exclusivă a producătorului; 5) Obiectul declarației; 6) Model/Tip; 7) Desemnare; 8) Descriere; 9) Obiectul declarației descris mai sus este în conformitate cu legislația relevantă de armonizare a Uniunii; 10) Directivă; 11) Standard; 12) Informații adiționale; 13) Semnat pentru și în numele

SLOVENSKÝ: 1) EU Vyhlásenie o zhode; 2) Číslo; 3) Výrobca; 4) Toto vyhlásenie o zhode sa vydáva na výhradnú zodpovednosť výrobcu; 5) Predmet vyhlásenia; 6) Model/Typ; 7) Označenie; 8) Popis; 9) Uvedený predmet vyhlásenia je v zhode s príslušnými harmonizačnými právnymi predpismi Unie; 10) Smernice; 11) Štandardné; 12) Doplnujúce informácie; 13) Podpísané za a mene na

SLOVENŠČINA: 1) Izjava EU o skladnosti; 2) Številko; 3) Proizvajalec; 4) Ta izjava o skladnosti je izdana na lastno odgovornost proizvajalca; 5) Predmet izjave; 6) Model/Type; 7) Oznaka; 8) Opis; 9) Predmet navedene izjave je v skladu z ustreznimi zakonodajami Unije o harmonizaciji; 10) Direktiva; 11) Standardna; 12) Dodatne informacije; 13) Podpisano za in v imenu

ESPAÑOL: 1) Declaración UE de conformidad; 2) Número; 3) Fabricante; 4) La presente declaración de conformidad es expedida bajo la exclusiva responsabilidad del fabricante; 5) Objeto de la declaración; 6) Tipo de modelo; 7) Designación; 8) Descripción; 9) El objeto de la declaración descrita anteriormente es conforme con la legislación de armonización pertinente de la Unión; 10) Directiva; 11) Estándar; 12) Información Adicional; 13) Firmado por y nombre

SVENSKA: 1) EU-Försäkran om överensstämmelse; 2) Nummer; 3) Tillverkare; 4) Denna försäkran om överensstämmelse utfärdas på tillverkarens eget ansvar; 5) Föremålet för försäkran; 6) Modell/Typ; 7) Beteckning; 8) Beskrivning; 9) Föremålet för försäkran ovan överensstämmer med den relevanta harmoniserade unionslagstiftningen; 10) Direktiv; 11) Standard; 12) Extra information; 13) Undertecknat för och på uppdrag av

EU DECLARATION OF CONFORMITY ^[1]

No. ^[2] **D0000356 (I.3)**

Manufacturer ^[3] Plockmatic International AB, Telefonvägen 30, S-126 26 Hägersten, Sweden

This declaration of conformity is issued under the sole responsibility of the manufacturer ^[4]

Object of the Declaration ^[5]	
Type/Model ^[6]	PL4700, F680
Name ^[7]	BST4000, BST4000-1, F680, Y980, BST6200, F656, PLBS
Description ^[8]	Belt Conveyor Stacker

The object of the declaration is in conformity with the requirements of the following documents ^[9]	
Directive ^[10]	Standard ^[11]
2014/30/EU (EMC)	CISPR 24:2010 + A1:2015, EN 55024:2010, EN 55032:2012 EN 61000-3-2:2014 EN 61000-3-3:2013 EN 62311:2008
2011/65/EU (RoHS)	EN 50581:2012 EN 62321:2009
2014/35/EU (LVD)	EN 60950-1:2006 + A1:2010 + A2:2013 + A11:2009 + A12:2011
Additional information ^[12] International certification: UL 60950-1, 2nd Edition, 2011-12-19, CAN/CSA C22.2 No. 60950-1-07, 2nd Edition, 2011-12, IEC 60950-1:2005 + A1:2009, FCC Part 15 (2015) Subpart B, Class A, ICES-003 Issue 6:2016, Class B	
Signed for and on behalf of ^[13] Hägersten, 2016-10-13 14:18	
 Bengt Olenfalk Group Quality Manager	

БЪЛГАРСКИ: 1) ЕС Декларация за съответствие; 2) Номер; 3) Производител; 4) Настоящата декларация за съответствие е издадена на отговорността на производителя; 5) Предмет на декларацията; 6) Модел/Тип; 7) Назначение; 8) Описание; 9) Предметът на декларацията, описан по-горе, отговаря на съответното законодателство на Съюза за хармонизация; 10) Директива; 11) Стандарт; 12) Допълнителна информация; 13) Подписано за и от името на

ČESKÝ: 1) EU Prohlášení o shodě; 2) Číslo; 3) Výrobce; 4) Toto prohlášení o shodě se vydává na výhradní odpovědnost výrobce; 5) Předmět prohlášení; 6) Model/Typ; 7) Označení; 8) Popis; 9) Výše popsaný předmět prohlášení je ve shodě s příslušnými harmonizačními právními předpisy Unie; 10) Směrnice; 11) Norma; 12) Dodatečné informace; 13) Podpisáno za a jménem na

DANSK: 1) EU-Overensstemmelseserklæring; 2) Nummer; 3) Producent; 4) Denne overensstemmelseserklæring udstedes på fabrikantens ansvar; 5) Erklæringens genstand; 6) Model/Type; 7) Betegnelse; 8) Beskrivelse; 9) Genstanden for erklæringen, som beskrevet ovenfor, er i overensstemmelse med den relevante EU-harmoniseringslovgivning; 10) Direktiv; 11) Standard; 12) Yderligere information; 13) Underskrevet for og vegne

DEUTSCH: 1) EU-Konformitätserklärung; 2) Nummer; 3) Hersteller; 4) Die alleinige Verantwortung für die Ausstellung dieser Konformitätserklärung trägt der Hersteller; 5) Gegenstand der Erklärung; 6) Modell/Typ; 7) Bezeichnung; 8) Beschreibung; 9) Der oben beschriebene Gegenstand der Erklärung erfüllt die einschlägigen Harmonisierungsrechtsvorschriften der Union; 10) Richtlinie; 11) Standard; 12) Weitere Informationen; 13) Zur Unterzeichnung und Namen

EESTI: 1) ELI Vastavusdeklaratsioon; 2) Number; 3) Valmistaja; 4) Käesolev vastavusdeklaratsioon on välja antud tootja ainuvastutusele; 5) Deklareeritav; 6) Model/Type; 7) Nimetus; 8) Kirjeldus; 9) Eelkirjeldatud deklareeritava toode on kooskõlas asjaomaste liidu ühtlustamisaktidega; 10) Direktiiv; 11) Standard; 12) Lisainfo; 13) Allkirjastatud ja nimel

SUOMI: 1) EU-Vaatimustenmukaisuusvakuutus; 2) Määrä; 3) Valmistaja; 4) Tämä vaatimustenmukaisuusvakuutus on annettu valmistajan yksinomaista vastuulla; 5) Vakuutuksen kohde; 6) Malli/Typppi; 7) Nimitys; 8) Kuvaus; 9) Edellä kuvattu vakuutuksen kohde on asiaa koskevan unionin yhdenmukaistamislainsäädännön vaatimusten mukainen; 10) Direktiivi; 11) Standardi; 12) Lisäinformaatio; 13) Allekirjoitettu ja puolesta

FRANÇAIS: 1) Déclaration UE de conformité; 2) Nombre; 3) Fabricant; 4) La présente déclaration de conformité est établie sous la seule responsabilité du fabricant; 5) Objet de la déclaration; 6) Modèle/type; 7) Désignation; 8) Description; 9) L'objet de la déclaration décrit ci-dessus est conforme à la législation d'harmonisation de l'Union applicable; 10) Directif; 11) Standard; 12) Information Supplémentaire; 13) Signé pour et au nom de

GAELIGE: 1) Dearbhú comhréireachta AE; 2) Uimhir; 3) Manufacturer; 4) Tá an dearbhú comhréireachta ama eisíúint faoi fheargracht an mhonáróra; 5) Cuspóir an dearbhairthe; 6) Cineál; 7) Ainmniú; 8) Tuairisc; 9) Is é cuspóir an dearbhairthe a thugair i gcomhréir leis an reachtaíocht chomhchuíbhithe ábhartha an Aontais; 10) Treoir; 11) Caigh deánach; 12) Eolas breise; 13) Ama shíniú le haghaidh agus thar ceann an

ΕΛΛΗΝΙΚΗ: 1) Δήλωση συμμόρφωσης ΕΕ; 2) αριθμός; 3) Κατασκευαστής; 4) Η παρούσα δήλωση συμμόρφωσης εκδίδεται με αποκλειστική ευθύνη του κατασκευαστή; 5) Αντικείμενο της δήλωσης; 6) Μοντέλο/Τύπος; 7) Ονομασία; 8) Περιγραφή; 9) Ο στόχος της δήλωσης που περιγράφεται παραπάνω είναι σύμφωνος με τη σχετική ενωσιακή νομοθεσία εναρμόνισης; 10) Διευθυντικός; 11) Πρότυπο; 12) Επιπλέον πληροφορίες; 13) Υπογραφή για λογαριασμό και εξ ονόματος του

HRVATSKI: 1) EU Izjava o sukladnosti; 2) Broj; 3) Proizvođač; 4) Za izdavanje EU izjave o sukladnosti odgovoran je isključivo proizvođač; 5) Predmet deklaracije; 6) Model/Tip; 7) Oznaka; 8) Deskripcija; 9) Predmet navedene izjave u skladu je s mjerodavnim zakonodavstvom Unije o usklađivanju; 10) Direktiva; 11) Standard; 12) Dodatne informacije; 13) Potpisao za i u ime

MAGYAR: 1) EU-Megfelelőségi nyilatkozat; 2) Szám; 3) Gyártó; 4) Ezt a megfeleléségi nyilatkozatot a gyártó kizárólagos felelőssége mellett adja ki; 5) A nyilatkozat tárgya; 6) Model/Tipus; 7) Kijelölés; 8) Leírás; 9) A fent ismertetett nyilatkozat tárgya megfelel a vonatkozó uniós harmonizációs jogszabályoknak; 10) Irányelv; 11) Standard; 12) További információ; 13) Aláírva nevében

ISLENSKA: 1) ESB Leyfyrirfyring; 2) Fjöldi; 3) Framleiðandi; 4) Þessi samræmisfyrirfyring er sett allan á ábyrgð framleiðanda; 5) Markmið fyrirfyringarrinnar; 6) Gerð; 7) Tilnefning; 8) Lýsing; 9) Markmið fyrirfyringarrinnar lýst er hér að ofan í samræmi við viðeigandi Union samræmingsföggjafar; 10) Tilskipun; 11) Standard; 12) Viðbótarupplýsingar; 13) Undirritað fyrir og fyrir hönd

ITALIANO: 1) Dichiarazione di conformità UE; 2) Numero; 3) Produttore; 4) La presente dichiarazione di conformità è rilasciata sotto la responsabilità esclusiva del fabbricante; 5) Oggetto della dichiarazione; 6) Modello/Tipo; 7) Designazione; 8) Descrizione; 9) L'oggetto della dichiarazione di cui sopra è conforme alla pertinente normativa di armonizzazione dell'Unione; 10) Direttiva; 11) Standard; 12) Informazioni aggiuntive; 13) Firmato e per conto di

LATVIEŠU: 1) ES Atbilstības deklarācija; 2) Numurs; 3) Ražotājs; 4) Šī atbilstības deklarācija ir izdota vienīgi uz ražotāja atbildību; 5) Deklarācijas priekšmets; 6) Modelis/tips; 7) Apzīmējums; 8) Apraksts; 9) Iepriekš aprakstītais deklarācijas priekšmets atbilst attiecīgajam Savienības saskaņošanas tiesību aktam; 10) Direktīva; 11) Standarts; 12) Papildus informācija; 13) Parakstīts vārda

LIETUVIŲ: 1) ES Atitikties deklaracija; 2) Skaicius; 3) Gamintojas; 4) Ši atitikties deklaracija išduota tik gamintojo atsakomybe; 5) Deklaracijos objektas; 6) Modelis/tipas; 7) Pavadinimas; 8) Aprašymas; 9) Pirmiau aprašytas deklaracijos objektas atitinka susijusius derinamuosius Sąjungos teisės aktus; 10) Direktyva; 11) Standartinė; 12) Papildoma informacija; 13) Pasirašyta ir vardu

MALTESE: 1) Dikjarazzjoni ta' konformità tal-UE; 2) Numru; 3) Manifattur; 4) Din id-dikjarazzjoni ta' konformità tinharha taht ir-responsabbiltà unika tal-manifattur; 5) Għan tad-dikjarazzjoni; 6) Mudell/Tip; 7) Deżinjazzjoni; 8) Deskrizzjoni; 9) L-għan tad-dikjarazzjoni deskritt hawn fuq huwa konformi mal-legislazzjoni ta' armonizzazzjoni rilevanti tal-Unjoni; 10) Direttiva; 11) Standard; 12) Informazzjoni addizzjonali; 13) Iffirmat għal u fisem il

NEDERLANDS: 1) EU-Conformiteitsverklaring; 2) Nummer; 3) Fabrikant; 4) Deze conformiteitsverklaring wordt verstrekt onder volledige verantwoordelijkheid van de fabrikant; 5) Voorwerp van de verklaring; 6) Model/Type; 7) Benaming; 8) Beschrijving; 9) Het hierboven beschreven voorwerp is in overeenstemming met de desbetreffende harmonisatiewetgeving van de Unie; 10) Richtlijn; 11) Standaard; 12) Aanvullende informatie; 13) Ondertekend voor en namens

NORSK: 1) EU-Erklæring; 2) Nummer; 3) Producent; 4) Denne samsvarserklæringen er utstedt under ansvar av produsenten; 5) Formålet med erklæringen; 6) Type; 7) Betegnelse; 8) Beskrivelse; 9) Formålet med erklæringen som er beskrevet ovenfor er i samsvar med relevante Union harmoniseringslovgivning; 10) Direktiv; 11) Standard; 12) Ytterligere informasjon; 13) Signert for og vegne av

POLSKI: 1) Deklaracja zgodności UE; 2) Numer; 3) Producent; 4) Niniejsza deklaracja zgodności wydana zostaje na wyłączną odpowiedzialność producenta; 5) Przedmiot deklaracji; 6) Model/Typ; 7) Oznaczenie; 8) Opis; 9) Wymieniony powyżej przedmiot niniejszej deklaracji jest zgodny z odpowiednimi wymaganiami unijnego prawodawstwa harmonizacyjnego; 10) Dyrektywa; 11) Standard; 12) Dodatkowe informacje; 13) Podpisano imieniem

PORTUGUÊS: 1) Declaração UE de conformidade; 2) Número; 3) Fabricante; 4) A presente declaração de conformidade é emitida sob a exclusiva responsabilidade do fabricante; 5) Objeto da declaração; 6) Modelo/Tipo; 7) A nome

ROMÂNĂ: 1) Declarația UE de conformitate; 2) Număr; 3) Producător; 4) Prezenta declarație de conformitate este emisă pe răspunderea exclusivă a producătorului; 5) Obiectul declarației; 6) Model/Tip; 7) Desemnare; 8) Descriere; 9) Obiectul declarației descris mai sus este în conformitate cu legislația relevantă de armonizare a Uniunii; 10) Directivă; 11) Standard; 12) Informații adiționale; 13) Semnat pentru și în numele

SLOVENSKÝ: 1) EU Vyhlašenje o zhode; 2) Číslo; 3) Výrobca; 4) Toto vyhlášení o zhode sa vydáva na výhradnú zodpovednosť výrobcu; 5) Predmet vyhlášenja; 6) Model/Typ; 7) Označenie; 8) Popis; 9) Uvedený predmet vyhlášenja je v zhode s príslušnými harmonizačnými právnymi predpismi Unie; 10) Smernice; 11) Standard; 12) Doplnujúce informácie; 13) Podpísano za a mene na

SLOVENŠČINA: 1) Izjava EU o skladnosti; 2) Številko; 3) Proizvajalec; 4) Ta izjava o skladnosti je izdana na lastno odgovornost proizvajalca; 5) Predmet izjave; 6) Model/Type; 7) Oznaka; 8) Opis; 9) Predmet navedene izjave je v skladu z ustrežno zakonodajo Unije o harmonizaciji; 10) Direktiva; 11) Standardna; 12) Dodatne informacije; 13) Podpisano za in v imenu

ESPAÑOL: 1) Declaración UE de conformidad; 2) Número; 3) Fabricante; 4) La presente declaración de conformidad se expide bajo la exclusiva responsabilidad del fabricante; 5) Objeto de la declaración; 6) Tipo de modelo; 7) Designación; 8) Descripción; 9) El objeto de la declaración descrita anteriormente es conforme con la legislación de armonización pertinente de la Unión; 10) Directiva; 11) Estándar; 12) Información Adicional; 13) Firmado por y nombre

SVENSKA: 1) EU-Försäkran om överensstämmelse; 2) Nummer; 3) Tillverkare; 4) Denna försäkran om överensstämmelse utfärdas på tillverkarens eget ansvar; 5) Föremålet för försäkran; 6) Modell/Typ; 7) Beteckning; 8) Beskrivning; 9) Föremålet för försäkran ovan överensstämmer med den relevanta harmoniserade unionslagstiftningen; 10) Direktiv; 11) Standard; 12) Extra information; 13) Undertecknat för och på uppdrag av

EU DECLARATION OF CONFORMITY [1]

No. [2] **D0001499 (D.4)**

Manufacturer [3] Plockmatic International AB, Telefonvägen 30, S-126 26 Hägersten, Sweden

This Declaration of Conformity is issued under the sole responsibility of the manufacturer [4]

Object of the Declaration [5]				
Type/Model [6]	F122-001	F122-002	F134-001	F135-001
Name [7]	RCT, RCT30	CT5010, CT5030, CST500, CST2000, PBM-RCT, RCT50, SD-RCT	SD-INT	PBM PUMO
Description [8]	Rotator Creaser Trimmer	Rotator Creaser Trimmer	Interface Module	Purge Module

The object of the declaration is in conformity with the relevant Union harmonization legislation: [9]	
Directive [10]	Standard [11]
2004/108/EC (EMC)	EN 55022:2010 (Class A), EN 55024:2010, EN 61000-3-2:2014, EN 61000-3-3:2013, EN 62311:2008
2011/65/EU (RoHS)	EN 50581:2012, EN 62321:2009
2014/35/EU (LVD)	EN 60950-1:2006 + A1:2010 + A2:2013 + A11:2009 + A12:2011
Additional information [12] International certification: UL 60950-1, 2nd Edition, 2014-10-14, CAN/CSA C22.2 No. 60950-1-07, 2nd Edition, 2014-10, IEC 60950-1:2005 (2nd Edition); Am 1:2009, FCC Part 15 (2012) Subpart B, Class B, ICES-003 Issue 5 Class B	
Signed for and on behalf of [13] Hägersten, 2016-04-04 14:33	
 Bengt Olenfalk Group Quality Manager	

БЪЛГАРСКИ: 1) ЕС Декларация за съответствие; 2) Номер; 3) Производител; 4) Настоящата декларация за съответствие е издадена на отговорността на производителя; 5) Предмет на декларацията; 6) Модел/Тип; 7) Назначение; 8) Описание; 9) Предметът на декларацията, описан по-горе, отговаря на съответното законодателство на Съюза за хармонизация; 10) Директива; 11) Стандарт; 12) Допълнителна информация; 13) Подписано за и от името на

ČESKY: 1) EU Prohlášení o shodě; 2) Číslo; 3) Výrobce; 4) Toto prohlášení o shodě se vydává na výhradní odpovědnost výrobce; 5) Předmět prohlášení; 6) Model/Typ; 7) Označení; 8) Popis; 9) Výše popsaný předmět prohlášení je ve shodě s příslušnými harmonizačními právními předpisy Unie; 10) Směrnice; 11) Norma; 12) Dodatečné informace; 13) Podepsáno za a jménem na

DANSK: 1) EU-Overensstemmelseserklæring; 2) Nummer; 3) Producent; 4) Denne overensstemmelseserklæring udstedes på fabrikantens ansvar; 5) Erklæringens genstand; 6) Model/Type; 7) Betegnelse; 8) Beskrivelse; 9) Genstanden for erklæringen, som beskrevet ovenfor, er i overensstemmelse med den relevante EU-harmoniseringslovgivning; 10) Direktiv; 11) Standard; 12) Yderligere information; 13) Underskrevet for og vegne

DEUTSCH: 1) EU-Konformitätserklärung; 2) Nummer; 3) Hersteller; 4) Die alleinige Verantwortung für die Ausstellung dieser Konformitätserklärung trägt der Hersteller; 5) Gegenstand der Erklärung; 6) Modell/Typ; 7) Bezeichnung; 8) Beschreibung; 9) Der oben beschriebene Gegenstand der Erklärung erfüllt die einschlägigen Harmonisierungsrechtsvorschriften der Union; 10) Direktive; 11) Standard; 12) Weitere Informationen; 13) Zur Unterzeichnung und Namen

EESTI: 1) ELi Vastavusdeklaratsioon; 2) Number; 3) Valmistaja; 4) Käesolev vastavusdeklaratsioon on välja antud tootja ainuvastutusele; 5) Deklareeritav; 6) Model/Type; 7) Nimetus; 8) Kirjeldus; 9) Eelkirjelatud deklareeritava toode on kooskõlas asjaomaste liidu ühtlustamisaktidega; 10) Direktiiv; 11) Standard; 12) Lisainfo; 13) Allkirjastatud ja nimel

SUOMI: 1) EU-Vaatimustenmukaisuusvakuutus; 2) Määrä; 3) Valmistaja; 4) Tämä vaatimustenmukaisuusvakuutus on annettu valmistajan yksinomaisella vastuulla; 5) Vakuutuksen kohde; 6) Malli/Typppi; 7) Nimitys; 8) Kuvaus; 9) Edellä kuvattu vakuutuksen kohde on asiaa koskevan unionin yhdenmukaistamislainsäädännön vaatimusten mukainen; 10) Direktiivi; 11) Standardi; 12) Lisäinformaatio; 13) Allekirjoitettu ja puolesta

FRANÇAIS: 1) Déclaration UE de conformité; 2) Nombre; 3) Fabricant; 4) La présente déclaration de conformité est établie sous la seule responsabilité du fabricant; 5) Objet de la déclaration; 6) Modèle/type; 7) Désignation; 8) Description; 9) L'objet de la déclaration décrit ci-dessus est conforme à la législation d'harmonisation de l'Union applicable; 10) Directif; 11) Standard; 12) Informations Supplémentaires; 13) Signé pour et au nom de

GAELIGE: 1) Dearbhú comhréireachta AE; 2) Uimhir; 3) Manufacturer; 4) Tá an dearbhú comhréireachta ama eisúint faoi threagracht an mhonaróra; 5) Cuspóir an dearbhalthe; 6) Cineál; 7) Ainmiú; 8) Tuairisc; 9) Is é cuspóir an dearbhalthe a thugtar i gcomhréir leis an reachtaíocht chomhchuíbhíthe ábhartha an Aontais; 10) Treoir; 11) Caighdeánach; 12) Eolas breise; 13) Ama shíniú le haghaidh agus thar ceann an

ΕΛΛΗΝΙΚΗ: 1) Δήλωση συμμόρφωσης ΕΕ; 2) αριθμός; 3) Κατασκευαστής; 4) Η παρούσα δήλωση συμμόρφωσης εκδίδεται με αποκλειστική ευθύνη του κατασκευαστή; 5) Αντικείμενο της δήλωσης; 6) Μοντέλο/Τύπος; 7) Ονομασία; 8) Περιγραφή; 9) Ο στόχος της δήλωσης που περιγράφεται παραπάνω είναι σύμφωνα με τη σχετική ενωσιακή νομοθεσία εναρμόνισης; 10) Διευθυντικός; 11) Πρότυπο; 12) Επιπλέον πληροφορίες; 13) Υπογραφή για λογαριασμό και εξ ονόματος του

HRVATSKI: 1) EU Izjava o sukladnosti; 2) Broj; 3) Proizvođač; 4) Za izdavanje EU izjave o sukladnosti odgovoran je isključivo proizvođač; 5) Predmet deklaracije; 6) Model/Tip; 7) Oznaka; 8) Deskripcija; 9) Predmet navedene izjave u skladu je s njezodavnim zakonodavstvom Unije o uskladjivanju; 10) Direktiva; 11) Standard; 12) Dodatne informacije; 13) Potpisao za i u ime

MAGYAR: 1) EU-Megfelelőségi nyilatkozat; 2) Szám; 3) Gyártó; 4) Ezt a megfeleléségi nyilatkozatot a gyártó kizárólagos felelőssége mellett adja ki; 5) A nyilatkozat tárgya; 6) Modell/Típus; 7) Kijelölés; 8) Leírás; 9) A fent ismertetett nyilatkozat tárgya megfelel a vonatkozó uniós harmonizációs jogszabályoknak; 10) Irányelv; 11) Standard; 12) További információ; 13) Aláírva nevében

ISLENSKA: 1) ESB Leyfisfyrirlysing; 2) Fjöldi; 3) Framleiðandi; 4) Þessi samræmisfyrirlysing er sett alfarir á ábyrgð framleiðanda; 5) Markmið fyrirlýsingarinnar; 6) Gerð; 7) Tilnefning; 8) Lýsing; 9) Markmið fyrirlýsingarinnar lýst er hér að ofan er í samræmi við viðeigandi Union samhæfingu löggjafar; 10) Tilskipun; 11) Standard; 12) Viðbótarupplýsingar; 13) Undirritað fyrir og fyrir hönd

ITALIANO: 1) Dichiarazione di conformità UE; 2) Numero; 3) Produttore; 4) La presente dichiarazione di conformità è rilasciata sotto la responsabilità esclusiva del fabbricante; 5) Oggetto della dichiarazione; 6) Modello/Tipo; 7) Designazione; 8) Descrizione; 9) L'oggetto della dichiarazione di cui sopra è conforme alle pertinenti normative di armonizzazione dell'Unione; 10) Direttiva; 11) Standard; 12) Informazioni aggiuntive; 13) Firmato e per conto di

LATVIEŠKI: 1) ES Atbilstības deklarācija; 2) Numurs; 3) Ražotājs; 4) Šī atbilstības deklarācija ir izdota vienīgi uz ražotāja atbildību; 5) Deklarācijas priekšmets; 6) Modelis/tips; 7) Apzīmējums; 8) Apraksts; 9) Iepriekš aprakstītais deklarācijas priekšmets atbilst attiecīgajam Savienības saskaņošanas tiesību aktam; 10) Direktīva; 11) Standarts; 12) Papildus informācija; 13) Parakstīts vārdā

LIEUTUVIŲ: 1) ES Atitikties deklaracija; 2) Skaičius; 3) Gamintojas; 4) Ši atitikties deklaracija išduota tik gamintojo atsakomybe; 5) Deklaracijos objektas; 6) Modelis/tipas; 7) Pavadinimas; 8) Aprašymas; 9) Pirmaia aprašytas deklaracijos objektas atitinka susijusius derinamuosius Sąjungos teisės aktus; 10) Direktiva; 11) Standartinė; 12) Papildoma informacija; 13) Pasirašyta ir vardu

MALTESE: 1) Dikjarazzjoni ta' konformità tal-UE; 2) Numru; 3) Manifattur; 4) Din id-dikjarazzjoni ta' konformità tinhareg taht ir-responsabbiltà unika tal-manifattur; 5) Għan tad-dikjarazzjoni; 6) Mudell/Tip; 7) Deżinjazzjoni; 8) Deskrizzjoni; 9) L-għan tad-dikjarazzjoni deskritt hawn fuq huwa konformi mal-legislazzjoni ta' armonizzazzjoni rilevanti tal-Unjoni; 10) Direttiva; 11) Standard; 12) Informazzjoni addizzjonali; 13) Iffirmat għal u f'isem il

NEDERLANDS: 1) EU-Conformiteitsverklaring; 2) Nummer; 3) Fabrikant; 4) Deze conformiteitsverklaring wordt verstrekt onder volledige verantwoordelijkheid van de fabrikant; 5) Voorwerp van de verklaring; 6) Model/Type; 7) Benaming; 8) Beschrijving; 9) Het hierboven beschreven voorwerp is in overeenstemming met de desbetreffende harmonisatiewetgeving van de Unie; 10) Richtlijn; 11) Standaard; 12) Aanvullende informatie; 13) Ondertekend voor en namens

NORSK: 1) EU-Erklæring; 2) Nummer; 3) Producent; 4) Denne samsvarserklæringen er utstedt under ansvar av produsenten; 5) Formålet med erklæringen; 6) Type; 7) Betegnelse; 8) Beskrivelse; 9) Formålet med erklæringen som er beskrevet ovenfor er i samsvar med relevante Union harmoniseringslovgivning; 10) Direktiv; 11) Standard; 12) Ytterligere informasjon; 13) Signert for og vegne av

POLSKI: 1) Deklaracja zgodności UE; 2) Numer; 3) Producent; 4) Niniejsza deklaracja zgodności wydana zostaje na wyłączną odpowiedzialność producenta; 5) Przedmiot deklaracji; 6) Model/Typ; 7) Oznaczenie; 8) Opis; 9) Wymieniony powyżej przedmiot niniejszej deklaracji jest zgodny z odpowiednimi wymaganiami unijnego prawodawstwa harmonizacyjnego; 10) Dyrektywa; 11) Standard; 12) Dodatkowe informacje; 13) Podpisano imieniem

PORTUGUÊS: 1) Declaração UE de conformidade; 2) Número; 3) Fabricante; 4) A presente declaração de conformidade é emitida sob a exclusiva responsabilidade do fabricante; 5) Objeto da declaração; 6) Modelo/Tipo; 7) A denominação; 8) Descrição; 9) O objeto da declaração acima descrito está em conformidade com a legislação de harmonização da União aplicável; 10) Diretiva; 11) Padrão; 12) Informações adicionais; 13) Assinado por e nome

ROMÂNĂ: 1) Declarația UE de conformitate; 2) Număr; 3) Producător; 4) Prezenta declarație de conformitate este emisă pe răspunderea exclusivă a producătorului; 5) Obiectul declarației; 6) Model/Tip; 7) Desemnare; 8) Descriere; 9) Obiectul declarației descris mai sus este în conformitate cu legislația relevantă de armonizare a Uniunii; 10) Directivă; 11) Standard; 12) Informații adiționale; 13) Semnat pentru și în numele

SLOVENŠKÝ: 1) EU Vyhlašenie o zhode; 2) Číslo; 3) Výrobca; 4) Toto vyhlásenie o zhode sa vydáva na výhradnú zodpovednosť výrobcu; 5) Predmet vyhlásenia; 6) Model/Typ; 7) Označenie; 8) Popis; 9) Uvedený predmet vyhlásenia je v zhode s príslušnými harmonizačnými právnymi predpismi Unie; 10) Smernice; 11) Standard; 12) Doplnkové informácie; 13) Podpísané za a na mene na

SLOVENŠČINA: 1) Izjava EU o skladnosti; 2) Številko; 3) Proizvajalec; 4) Ta izjava o skladnosti je izdana na lastno odgovornost proizvajalca; 5) Predmet izjave; 6) Model/Type; 7) Oznaka; 8) Opis; 9) Predmet navedene izjave je v skladu z ustrežno zakonodajo Unije o harmonizaciji; 10) Direktiva; 11) Standard; 12) Dodatne informacije; 13) Podpisano za in v imenu

ESPAÑOL: 1) Declaración UE de conformidad; 2) Número; 3) Fabricante; 4) La presente declaración de conformidad se expide bajo la exclusiva responsabilidad del fabricante; 5) Objeto de la declaración; 6) Tipo de modelo; 7) Designación; 8) Descripción; 9) El objeto de la declaración descrita anteriormente es conforme con la legislación de armonización pertinente de la Unión; 10) Directiva; 11) Estándar; 12) Información Adicional; 13) Firmado por y nombre

SVENSKA: 1) EU-Försäkran om överensstämmelse; 2) Nummer; 3) Tillverkare; 4) Denna försäkran om överensstämmelse utfärdas på tillverkarens eget ansvar; 5) Föremålet för försäkran; 6) Modell/Typ; 7) Beteckning; 8) Beskrivning; 9) Föremålet för försäkran ovan överensstämmer med den relevanta harmoniserade unionslagstiftningen; 10) Direktiv; 11) Standard; 12) Extra information; 13) Undertecknat för och på uppdrag av

Cables, plugs and jumpers

Schematical description of how to connect communication cables, termination plugs and interlock jumpers on all possible system configurations.

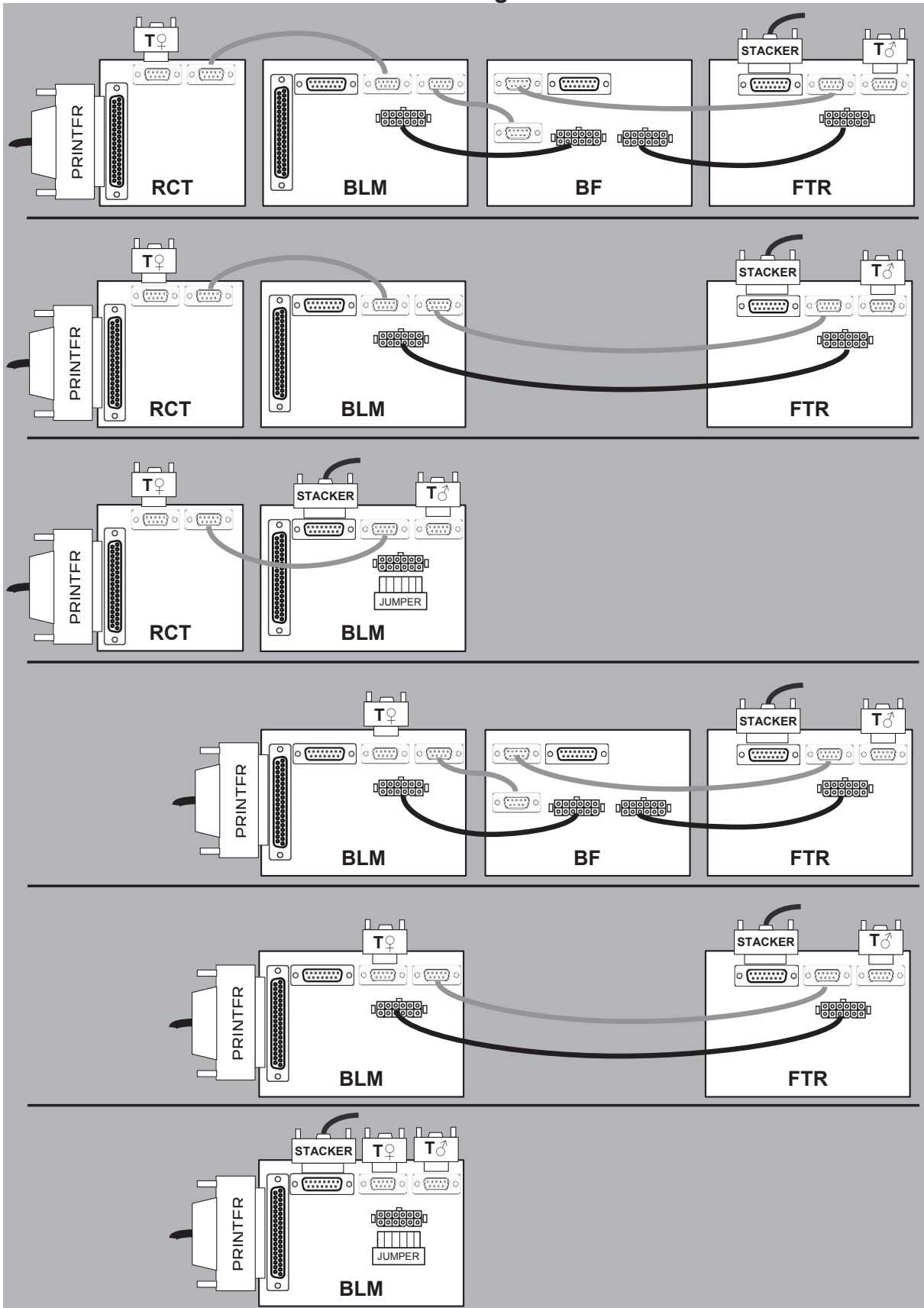

INDEX

A

Access to machine 81
Adjustment of Bleed Trimmer registration angle (parallel cut) 91
Air Separation 47
Alive logo 24
Auto Rotate 58
AUTO sheet size 43
Auto trimming 43

B

Basics 33
Basic settings 42
Belt stacker 71
Belt Stacker 30, 37
Belt stacker fault codes 77
Best practices for the SD-350/SD-500 system 93
Bleed Trimmer - Asymmetric Side Trim 52
Bleed Trimmer - Cover Adjust 52
Booklet Maker 13, 64
Booklet Maker fault codes 74
BST4000-1 Belt Stacker Module 100

C

Cables, plugs and jumpers 105
Change left/right staple cartridge(s) 34
Changing settings 42
Check left/right stapler 35
Cleaning feed belts 83
Cleaning feed rollers and paper separator pad 82
Cleaning of creaser tools (2x) 90
Cleaning the fixing rollers (3x) 86
Cleaning the paper path sensors (5x) 88
Cleaning the paper path transportation nip rollers (6x) 85
Cleaning the registration cross roller (4x) 87
Cleaning the rotator rollers (2x) 88
Clearing Misfeed(s) 61
Control panel 16
Cover 46
Cover Feeder 25, 35, 67
Cover Feeder fault codes 75
Crease 50
Crease Mode 50
Crease position 50
Custom booklet size 44
Customizing settings 45

D

Declaration of Conformity 102
Do's And Don'ts 79
Double Sheet Detection 47

E

Emptying the trim bin 36

F

Fault codes 73
Fine-tuning booklet appearance 51
Finished Booklet Size 43
Fold delay 57
Fold position 46

G

General fault codes 78
General safety 4
Guided Start 39
Guide To Components 13

H

Hand-feeding 53
Hand feed mode 53
Handling jobs 59
How to read this manual 3

I

Input Sheet Size 42
Introduction 3

J

Jobs 59

L

Language 56
Limitations of the SD-350/SD-500 system 94
Loading covers 35

M

Machine environment 80
Machine Specifications 97
Maintaining Your Machines 82
Making Booklets 39

O

Off-line mode 53
Opening and handling stored Jobs 60
Options 19

P

Paper path light 56
Plockmatic Cover Feeder 99
Power connection 80
Pressure springs 84
Purge Cover 48

R

RCT fault codes 73
RCT Module 85
REMARKS 79
Rotate Crease Trim Module (option) 97

S

Safety during operation 4
Safety Information 4
Saving a Job 59
SD-BM350/500 Booklet Maker 98
Selecting BookFold pressure setting 49
Selecting standard paper sizes 42
Service mode 57
Set registration (fine adjustment) 51
Setting up Belt Stacker 37

Sheet feeder 57
Software version 56
Specification 97
BookFold Module 26
BookFold Module, clearing misfeeds 68
BookFold Module fault codes 76
BookFold Module, maintaining 83
BookFold Module 100
BookFold offset 58
Stacker full detection 55
Staple 45
System Set Size Guide 101

T

Tools 55
Trimmer 28, 69
Trimmer fault codes 77
Trimmer Module 99
Troubleshooting 73
Turning On / Off the Main Power 33

U

Units 55
User interface 16

W

What You Can Do With This Machine 11
Where to put Your Machine 80

