

DRX-Revolution Mobile X-ray System



Safety and Regulatory Information

Carestream

**2012-02-28
9J0239
Version 4.0**

Table of Contents

1 Safety and Regulatory Information

Manual Conventions	1
Overview	1
Indications for Use	2
Training	2
Safety and Related Information.....	3
Manufacturer’s Responsibility	3
Safety Symbols.....	4
Radiation and X-ray System	6
Safety and General Compliance Information	6
Maximum Permissible Dose (MPD)	7
Radiographic Performance	7
Radiation Protection	8
CDRH Compliance.....	9
Classification in Accordance with IEC 60601-1.....	9
IEC/EN 60601-1-3 Compliance.....	9
Conforming Safety Standards.....	10
USA	10
Canada.....	10
Europe.....	10
International	10
Cautions.....	11
Equipment Cautions	11
Electrical/Mechanical.....	11
Mechanical	11
General Use Cautions and Special Messages	12
Moving and Equipment Use Cautions.....	12
Electrical and Flammable Cautions.....	13
Radiation and Magnetic Field Cautions	13
Cleaning Cautions.....	13
Caution Regarding Small-Object Image Handling	14
Restrictions on Use	15

Disposal.....	16
Usability.....	16
Conforming EMC Standards	17
For European Market Only.....	17
System Requirements.....	17
US and Canada EMC Statements	18
Electromagnetic Emissions/Immunity	19
Wireless.....	25
DRX-Revolution Wireless Systems	25
DRX-1 and DRX-1C System Detectors.....	25
Grid Alignment Transmitter.....	25
Wireless Compliance Information for EU Directive 1999/5/IEC.....	26
Grid Alignment Intended Use	26
EC Declaration of Conformity.....	27
Compliance: Grid Alignment	29
National Usage Restrictions.....	31
Collision Sensing Feature	32
Patient Vicinity.....	32
X-ray Tube and Collimator	33
X-ray Tube	33
Collimator.....	33
Accessories.....	33
Flammability	33
Method of Cleaning.....	33
Extra Focal Dimensions	34
Labels	36
Systems Label Locations.....	36
Detector /Grid Holder Weight Limit Label	38
Product Disclosure Table.....	39

1 Safety and Regulatory Information

The information contained herein is based on the experience and knowledge relating to the subject matter gained by Carestream Health, Inc. prior to publication.

No patent license is granted by this information.

Carestream Health, Inc. reserves the right to change this information without notice, and makes no warranty, express or implied, with respect to this information. Carestream Health shall not be liable for any loss or damage, including consequential or special damages, resulting from any use of this information, even if loss or damage is caused by Carestream Health's negligence or other fault.

Manual Conventions

NOTE: The original documentation is written in English.

This manual uses three types of messages to emphasize information or potential risks to personnel or equipment: **Note**, **Important** and **Caution**.

NOTE: Notes provide additional information, such as expanded explanations, hints, or reminders.

IMPORTANT: *Important highlights critical policy information that affects how you use this manual and this product.*



CAUTION:

Cautions point out procedures that you must follow precisely to avoid injury to yourself, others, damage to the System or any of its components, loss of data, or corruption of files in software applications. Disregarding the caution statement may lead to abnormal use.

Overview

The CARESTREAM DRX Mobile X-ray System is a mobile imaging system that incorporates a self contained X-ray generator, image receptor, imaging display and software for acquiring medical diagnostic images outside a standard X-ray room. It is a mobile diagnostic system intended to generate and control X-rays for examination of various anatomical regions.

The System is designed for use in all locations of a hospital or clinical site, including patient rooms, operating rooms, emergency departments, trauma bays, Intensive Care Units (ICU), and other patient treatment areas.

Personnel operating and maintaining the System should receive training and be familiar with all aspects of operation and maintenance. To ensure safety, read the Safety Information section carefully before using the System and observe all **Cautions, Importants, and Notes** located throughout this manual and other manuals supplied with the equipment.

From this point forward, all references to the DRX -Revolution System will be referred to as the System.

Indications for Use

The device is designed to perform radiographic X-ray examinations on all pediatric and adult patients, in all patient treatment areas.

Training

This equipment is intended for use by appropriately trained and skilled radiological health care professionals who have received specific training on the operation and use of this equipment.



CAUTION:

Only qualified personnel may operate the System. Operation of the equipment by persons who have not been trained or who are unfamiliar with the functions and controls of the System may cause serious injury to the patient, serious injury to the operator, or equipment damage.



CAUTION:

Only allow trained X-ray personnel to operate the System.

For training in the operation of this equipment, contact Carestream Health, Inc.

Safety and Related Information

Manufacturer's Responsibility

Although this equipment incorporates protection against X-radiation other than the useful beam, practical design does not provide complete protection. Equipment design does not compel the operator or assistants to take the necessary precautions; nor does it prevent the possibility of improper use (authorized or unauthorized persons carelessly, unwisely, or unknowingly exposing themselves or others to direct or secondary radiation). Allow only authorized, properly trained personnel to operate this equipment.

Be certain that all individuals authorized to use the equipment are aware of the danger of excessive exposure to X-radiation.

This equipment is sold with the understanding that the manufacturer, its agents, and its representatives do not accept any responsibility for overexposure of patients or personnel to X-radiation.

Furthermore, the manufacturer does not accept any responsibility for overexposure of patients or personnel to X-radiation generated by this equipment as a result of them not following proper operating techniques or procedures.

No responsibility is assumed for any unit that has not been serviced and maintained in accordance with the technical service manual, or that has been modified or tampered with in any way.

Safety Symbols

The following symbols may be used for marking on this equipment:



Emergency Stop button



Follow the operating instructions



Warning—dangerous voltage



Dangerous voltage



Warning— ionizing radiation



Type B applied part



Direct current



Alternating current



Collimator light



Off (disconnect from the mains)



On (power connected to the mains)



Off (only for a part of the **equipment**)



On (only for a part of the **equipment**)



Caution



Non-ionizing radiation



Tether cable



Ethernet connection



USB connection



Protective earth (ground)



Transport position

Radiation and X-ray System

Safety and General Compliance Information

Occupational workers associated with X-ray work must be familiar with the recommendations of the Center for Devices and Radiological Health (CDRH), the National Council on Radiation Protection (NCRP), the International Commission on Radiation Protection (ICRP), and state and local regulations.

Be sure that all personnel authorized to operate the System are familiar with the established regulations of the authorities named above. All personnel should be monitored to ensure compliance with recommended procedures.

Current sources of information include:

- NCRP Report 147: Structural Shielding Design for Medical Imaging Facilities
- Current recommendations of the International Committee on Radiation Protection
- State or local requirements for radiation protection

Although exposure to high levels of X-radiation may pose a health risk, System X-ray equipment does not pose any danger when properly used. Be certain all operating personnel are properly educated concerning the hazards of radiation. Persons responsible for the System must understand the safety requirements and special warnings for X-ray operation. Review this manual and the manuals for each component in the System to become aware of all safety and operation requirements.



CAUTION:

Ensure exposure parameters are properly adjusted within safety limits.



CAUTION:

Incorrect Collimator adjustment may cause unnecessary patient X-ray exposure. See the *DRX-Revolution Mobile X-ray System Hardware Guide* for instructions for adjusting the size of the exposure area.



CAUTION:

Incorrect X-ray Tube and Collimator position could cause the X-ray field to be misaligned with the receptor, resulting in unacceptable images.



CAUTION:

Materials between the Tube and the patient may adversely affect the resulting image.

Maximum Permissible Dose (MPD)

Various studies on the effects of X-radiation have provided a foundation for establishing the maximum permissible dose of X-radiation to which an occupational worker may be exposed. The results of these studies have been used by the NCRP and the ICRP to develop recommendations for MPD. In addition, state or local regulators also provide mandatory occupational exposure limits with which to comply.

Occupational Exposure Limits

Whole body: 5.0 rem/year

Extremity: 50.0 rem/year

Declared pregnant occupational worker: 0.5 rem/gestation period

Radiographic Performance

kVp Range	40–150 kVp
kVp Accuracy	$\pm(5\% + 1)$ kVp, measured 5 ms after the beginning of the exposure; $\pm 2\%$ between 70–85 kVp
Ripple (kVp)	$\pm 5\%$ p–p over the full operating range (for ripple frequency ≥ 10 kHz)
Risetime (10– 90 %)	< 2.0 ms (typically < 1.5 ms)
mAs Accuracy	$\pm(10\% + 0.20)$ mAs: > 0.5 mAs $\pm (10\% + 0.5$ mAs: 0.1 mAs–0.5 mAs
Coefficient of linearity	0.1 (Station to Station) for exposures ≥ 25.0 mA or 3.2 ms
Coefficient of Reproducibility	< 0.05 for kVp and mAs parameters

Radiation Protection

Because exposure to high levels of X-radiation may pose a health risk, operators must ensure that they use all available methods to reduce their radiation dose to a level that is As Low As Reasonably Achievable (ALARA). This includes protection from the primary beam as well as scattered radiation. Protection from excessive amounts of exposure is accomplished using a combination of engineering and administrative controls.

- **Portable Barriers and Lead Aprons**—Portable barriers and lead aprons may be needed to protect personnel from scattered radiation if operators need to be in close contact with the patient. Make sure that the shielding and aprons have sufficient lead equivalence, as determined by a qualified Health or Medical Physicist, and are maintained properly for maximum benefit.
- **Procedures**—Always follow the procedures of your institution to ensure proper protection.
- **Training**—Medical equipment should be operated by trained personnel only. Most regulatory agencies require that medical diagnostic procedures be done only by properly licensed individuals. Consult your state or local agencies for more information.
- **Radiation Survey**—Monitor the exterior of the X-ray facility (outside the primary protective barrier) and control room periodically to ensure that dose rates meet design objectives for allowable radiation exposures. A qualified Health or Medical Physicist should use only calibrated equipment for this survey.
- **Personal Monitoring**—Monitor occupational workers that use X-ray equipment for X-ray exposure to ensure that established controls are functioning properly and procedures are being followed. Typically, film badges or similar devices are used. Film badges use X-ray sensitive film enclosed in a holder that incorporates metal filters of varying degrees of transparency to X-ray radiation. Even though this device only measures the radiation reaching the area of the body on which it is worn, it provides an indication of the amount of radiation received. Film badges can also be used as area dosimeters on the outside perimeter of the X-ray facility and control room to verify dose rates.

Film badges are available from a number of distributors. Consult your institution's Radiation Safety Officer for further information.

IMPORTANT: *Use a source-to-skin distance as large as possible to keep the absorbed dose as low as reasonably achievable. The Operator Console must be located where there is audio and visual communication between the radiographer and the patient.*

CDRH Compliance

The X-ray System complies with Department of Health and Human Services radiation performance standards per Title 21 CFR, Chapter 1, Subchapter J.

Classification in Accordance with IEC 60601-1

Type of protection against electrical shock	Class I equipment/Internally powered
Degree of protection against electrical shock	Type B protection against electrical shock
Degree of protection against ingress of water	Ordinary protection
Mode of operation	Continuous operation with intermittent loading
Flammable anesthetics	Not suitable for use in the presence of flammable anesthetics or a mixture of flammable anesthetics with air or oxygen or nitrous oxide

IEC/EN 60601-1-3 Compliance

The System is manufactured with radiation protection in accordance with IEC/EN 60601-1-3:1994.

Electrical Rating	
DRX-Revolution Mobile X-ray System	Voltage: 100/120/200/240/ VAC
	Current: 4.4/12.0/7.2/6.0 A
	Frequency: 50/60 Hz
DRX-Revolution Grid Holder	Voltage: 3.2 V (dc)
	Current: 1.5 A
CARESTREAM DRX-1/DRX-1C System Detector	Voltage: 12–18 V(dc)
	Current: 3.0 A

Conforming Safety Standards

USA

UL 60601-1:2003 Medical Electrical Equipment, Part 1: General Requirements for Safety

Canada

CAN/CSA-C22.2 No. 601.1-M90—Medical Electrical Equipment—Part 1: General Requirements for Safety

Europe

EN 60601-1:1990 + A1 + A2—Medical Electrical Equipment—Part 1: General Requirements for Safety

EN 60601-1-1:2001—Medical Electrical Equipment—Part 1-1: General requirements for safety—Collateral standard: Safety requirements for medical electrical systems

EN 60601-1-3:1994—Medical Electrical Equipment—Part 1-3: General requirements for safety—3. Collateral standard: General requirements for radiation protection in diagnostic X-ray equipment

EN 60601-1-4:1996 +A1—Medical Electrical Equipment—Part 1-4: General requirements for safety—Collateral standard: Programmable electrical medical systems

EN 60601-6:2004—Medical Electrical Equipment—Part 1-6: General requirements for safety—Collateral standard: Usability

EN 60601-2-32:1994—Medical Electrical Equipment—Part 2-32: Particular requirements for the safety of associated equipment of X-ray equipment

International

IEC 60601-1:1988 + A1 + A2—Medical Electrical Equipment—Part 1: General Requirements for Safety

IEC 60601-1-1:2000—Medical Electrical Equipment—Part 1-1: General requirements for safety—Collateral standard: Safety requirements for medical electrical systems

IEC 60601-1-3:1994—Medical Electrical Equipment—Part 1-3: General requirements for safety—3. Collateral standard: General requirements for radiation protection in diagnostic X-ray equipment

IEC 60601-1-4:1996 +A1—Medical Electrical Equipment—Part 1-4: General requirements for safety—Collateral standard: Programmable electrical medical systems

IEC 60601-1-6:2004 - Medical Electrical Equipment—Part 1-6: General requirements for safety—Collateral standard: Usability

IEC 60601-2-32:1994—Medical Electrical Equipment—Part 2-32: Particular requirements for the safety of associated equipment of X-ray equipment

Cautions

Equipment Cautions

The following are general safety precautions:

- Do not remove the covers for any purpose.
- Do not defeat or bypass built-in equipment safety features.
- Observe all cautions, stated or implied, in the procedures.
- Follow all safety labels on the equipment.



CAUTION:

Do not attempt any repairs if the equipment fails to operate correctly. Immediately call a person qualified and authorized to repair the equipment.

Electrical/Mechanical



CAUTION:

Only a qualified authorized Service Provider should replace electrical and mechanical components.

Mechanical

The following are mechanical safety precautions:

- Keep fingers, hands, and tools clear of moving parts.
- Do not operate the equipment with covers or access panels removed.
- Route cables properly to eliminate hazards from tripping.



CAUTION:

Retract the boom and place in a docked position anytime the cart is driven. Do not release the boom from a locked position on a surface that slopes more than 5 °.

General Use Cautions and Special Messages



WARNING: THIS X-RAY UNIT MAY BE DANGEROUS TO PATIENT AND OPERATOR UNLESS SAFE EXPOSURE FACTORS, OPERATING INSTRUCTIONS AND MAINTENANCE SCHEDULES ARE OBSERVED.

P/N 7H3208 REV A []



CAUTION:

Use of controls or adjustments or performance of procedures other than those specified herein may result in hazardous radiation exposure.



CAUTION:

Do not operate this equipment outside of its operating environment limits. Doing this may cause the equipment to malfunction.



CAUTION:

The System includes no user serviceable parts. Contact Carestream Health, Inc. for service information.



CAUTION:

This device must be maintained according to the directions in the System Hardware Guide. Failure to maintain this equipment as directed may result in injury, equipment malfunction, or unacceptable images.



CAUTION:

United States federal law restricts this device to sale by or on the order of a physician.



CAUTION:

The user must pay attention to possible adverse effects from materials located in the X-ray beam.



CAUTION:

Excessive use of the virtual keyboard may result in repetitive strain injury.





CAUTION:

The equipment is fragile and must be handled with care.

Moving and Equipment Use Cautions

Electrical and Flammable Cautions

 **CAUTION:**
Only allow trained X-ray personnel to use the Operator Console.

 **CAUTION:**
The System is not suitable for operation in the presence of a flammable anesthetic mixture with air, oxygen, or nitrous oxide.

Radiation and Magnetic Field Cautions

 **CAUTION:**
The System produces ionizing radiation. Operators must meet all international, national, state, and local requirements and regulations.

 **CAUTION:**
This X-ray unit may be dangerous to patients and operators unless safe exposure factors and operating instructions are observed.

Cleaning Cautions

 **CAUTION:**
Do not operate the equipment when cleaning the equipment.

 **CAUTION:**
Do not spray cleaning or disinfecting solution directly onto the equipment. Moisten a cloth with a 70 % isopropyl alcohol solution for use on plastics and enameled metal. Apply to patient contact areas after each contact.

 **CAUTION:**
Isopropyl alcohol is a flammable solvent. Read and follow instructions in the Material Safety Data Sheet (MSDS).

 **CAUTION:**
Do not immerse the equipment in liquid.

NOTE: For instructions on cleaning the equipment, see the *DRX-Revolution Mobile X-ray System Hardware Guide*.

Caution Regarding Small-Object Image Handling

As with all digital imaging devices, there is the potential that some structures could appear different in the digital image from an image created with an analog device—such as a screen-film system—or with another digital device that has smaller individual detector elements. These structures include small-detail structures, high-contrast edge structures, and fine-line structures with a repeating pattern. For example, the edges of a sharp-edged object may appear to have “stair-steps” when the object edge does not have such structure. This is an effect of digital sampling.

For small-detail objects having a size on the same order of magnitude as an individual pixel or smaller, the apparent contrast of that object can vary based on the position relative to the individual detector element locations. For example, the contrast of a single spherical object the same size as a pixel would have a dramatically different appearance if the object were imaged directly overlying a detector element (highest contrast) or placed at the intersection of four detector elements (lowest contrast). Objects inherently smaller than individual pixels have a lower apparent contrast because of the digital sampling of the analog radiation intensity signal over an area larger than the small object. In each case, a lower apparent signal-to-noise can result in reduced visibility of such objects.

Restrictions on Use

The user must make sure that any equipment used with the System does not compromise the System patient contact rating.

The user is also responsible for safety and EMC compliance of any non-Carestream Health recommended, installed, or supplied accessory equipment.

The use of accessory equipment and/or hardware not complying with the equivalent product safety and EMC requirements of this product may lead to a reduced level of safety and/or EMC performance of the System.

Consideration relating to the choice of accessory equipment used with this product shall include:

- Use of the accessory in the patient's vicinity.
- Evidence that the safety certification of the accessory has been performed in accordance with applicable coordinated harmonized product safety standards per IEC 60601-1-1.
- Evidence that applicable emission certification of the accessory has been performed.



CAUTION:

Observe all safety precautions recommended by the accessory equipment manufacturer in the user documentation provided with the equipment.

The hardware specified for use with the System has been selected, tested, and verified by Carestream Health, Inc. to meet the intended applications. All specified hardware meets applicable regulatory agency requirements for those countries where it is offered for sale with respect to its intended applications. Consult the user documentation included with the equipment for specific information relating to product safety and EMC compliance.

Disposal



CAUTION:

This product contains lead in sealed lead-acid batteries and in the counterweight.. Disposal of components that contain these materials may be regulated due to environmental conditions. For disposal or recycling information, contact your local authorities.



CAUTION:

The flat panel display in this System contains mercury. Disposal is regulated due to environmental considerations. Return the equipment to the manufacturer for proper disposal.

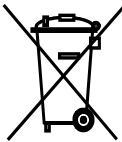

In the European Union, this symbol indicates that when the last user wishes to discard this product, it must be sent to appropriate facilities for recovery and recycling. See <http://recycle.carestreamhealth.com> for additional information on the collection and recovery programs available for this product.



Usability

The design and development of a diagnostic X-ray system incorporated a usability engineering process in accordance with the standard: IEC 60601-1-6: Medical Electrical Equipment, Part —6: General requirements for safety -Collateral\Standard: Usability.

It is not possible or practical to resolve every potential usability issue without affecting the intended use of the System. Therefore, some precautions must be observed. These precautions appear throughout the manual.

IMPORTANT: *Warning statements and the explanation of warning symbols marked on the equipment are provided in this document.*

Conforming EMC Standards

**For European Market
Only**



Carestream Health France
1, rue Galilée
93192 NOISY-LE-GRAND CEDEX
FRANCE

System Requirements

Equipment and systems meet the following requirements:

IEC 60601-1-2:2007 Medical Electrical Equipment—Electromagnetic Compatibility Requirements and Tests, including CISPR 11:2009 + A1:2010 emissions to Class A limits.



CAUTION:

This is a Class A product. In a domestic environment this product may cause radio interference, in which case the user may be required to take adequate measures.

93/42/EEC MDD (Medical Device Directive—Europe Only)

US and Canada EMC Statements

Changes or modifications not expressly approved by Carestream Health, Inc. could void the user's authority to operate this equipment.

NOTE: This equipment has been tested and found to comply with the limits for a Class A digital device, pursuant to part 15 of the FCC Rules. These limits are designed to provide reasonable protection against harmful interference when the equipment is operated in a commercial environment. This equipment generates, uses, and radiates radio frequency energy. If it is not installed and used in accordance with the instruction manual, it may cause harmful interference to radio communications. Operation of this equipment in a residential area is likely to cause harmful interference, in which case the user will be required to correct the interference at his own expense.

This device complies with part 15 of the FCC Rules. Operation is subject to the following two conditions:

1. This device may not cause interference.
2. This device must accept any interference received, including interference that may cause undesired operation.

This device complies with Industry Canada license-exempt RSS standard(s). Operation is subject to the following two conditions:

1. This device may not cause interference.
2. This device must accept any interference, including interference that may cause undesired operation of the device.

Le présent appareil est conforme aux CNR d'Industrie Canada applicables aux appareils radio exempts de licence. L'exploitation est autorisée aux deux conditions suivantes:

1. L'appareil ne doit pas produire de brouillage.
2. L'utilisateur de l'appareil doit accepter tout brouillage radioélectrique subi, même si le brouillage est susceptible d'en compromettre le fonctionnement.

Electromagnetic Emissions/Immunity

1. Electromagnetic Compatibility Precautions

Medical electrical equipment requires special precautions regarding electromagnetic compatibility (EMC). Medical equipment must be installed and put into service according to the EMC information provided.

2. Communications Equipment

Portable and mobile radio frequency (RF) communications equipment can affect medical electrical equipment EMC performance.

3. Replacement of cables, or accessories, other than those specified below with the exception of transducers or cables sold by the equipment manufacturer as replacement parts for internal components, may result in increased emissions or decreased immunity of the medical equipment.

4. Cable and accessory information for the System:

Cable Information for the System

Port/Cable		Function	User	Cable Length
USB	1	BlueTooth	Customer	NA
	2	Keyboard/Mouse/DVD	Service	1 Meter
	3	Keyboard/Mouse/DVD	Service	1 Meter
Ethernet	1	Hospital Uplink	Customer	3 Meter
Ethernet	1	Tethered Detector Link	Customer/ Service	3 Meter
Prep/Expose Hand Switch	1	Prep/Expose/Collimator Light Controller	Customer	3 Meter
AC Power Cord	1	Retractable	—	3 Meter

5. Shielded Locations

The System is fully compliant with the requirements of IEC 60601–1–2: 2007 without being used in a shielded room.

Electromagnetic Emissions for Group 1, Class A Equipment		
The System is intended for use in the electromagnetic environment specified below. The customer or the user of the System should assure that it is used in such an environment.		
Emissions Test	Compliance	Electromagnetic Environment - Guidance
RF Emissions CISPR 11	Group 1	The System uses RF energy only for its internal function. Therefore, its RF emissions are very low and are not likely to cause any interference in nearby electronic equipment.
RF Emissions CISPR 11	Class A	The System is suitable for use in all establishments other than domestic establishments and those directly connected to the public low-voltage power supply network that supplies buildings for domestic purposes.
Harmonics Emissions IEC 61000-3-2	Class A	
Voltage Fluctuations/ Flicker Emissions IEC 61000-3-3	Complies	

Electromagnetic Immunity for Equipment and Systems Fully Compliant with IEC 60601-1-2:2007

The System is intended for use in the electromagnetic environment specified below. The customer or the user of the System should assure that it is used in such an environment.

Immunity Test	IEC 60601 Test Level	Compliance Level	Electromagnetic Environment—Guidance
Electrostatic Discharge (ESD) IEC 61000-4-2	± 6 kV contact ± 8 kV air	± 6 kV contact ± 8 kV air	Floors should be wood, concrete, or ceramic tile. If floors are covered with synthetic material, the relative humidity should be at least 30 %.
Electrical fast transient/burst IEC 61000-4-4	± 2 kV for power supply lines ± 1 kV for input/output lines	± 2 kV for power supply lines ± 1 kV for input/output lines	Mains power quality should be that of a typical commercial or hospital environment.
Surge IEC 61000-4-5	± 1 kV differential mode ± 2 kV common mode	± 1 kV differential mode ± 2 kV common mode	Mains power quality should be that of a typical commercial or hospital environment.
Voltage dips, short interruptions, and voltage variations on power supply lines IEC 61000-4-11	<5 % U_T (>95 % dip in U_T) for 0.5 cycle 40 % U_T (60 % dip in U_T) for 5 cycles 70 % U_T (30 % dip in U_T) for 25 cycles. <5 % U_T (>95 % dip in U_T) for 5 s	<5 % U_T (>95 % dip in U_T) for 0.5 cycle 40 % U_T (60 % dip in U_T) for 5 cycles 70 % U_T (30 % dip in U_T) for 25 cycles. <5 % U_T (>95 % dip in U_T) for 5 s	Mains power quality should be that of a typical commercial or hospital environment. If the user of the System requires continued operation during power mains interruptions, it is recommended that the System be powered from an alternate AC power source.
Power frequency (50/60 Hz) magnetic field IEC 61000-4-8	3 A/m	3 A/m	Power frequency magnetic fields should be at levels characteristic of a typical location in a typical commercial or hospital environment.

Electromagnetic Immunity for Non-Life Supporting Equipment and Systems

The System is intended for use in the electromagnetic environment specified below. The customer or the user of the System should assure that it is used in such an environment.

Immunity Test	IEC 60601 Test Level	Compliance Level	Electromagnetic Environment—Guidance
<p>Conducted RF IEC 61000-4-6</p> <p>Radiated RF IEC 61000-4-3</p>	<p>3 Vrms 150 kHz to 80 MHz</p> <p>3 v/m 80 MHz to 2.5 GHz</p>	<p>3 Vrms</p> <p>3 v/m</p>	<p>Portable and mobile RF communications equipment should be used no closer to any part of the System, including cables, than the recommended separation distance calculated from the equation applicable to the frequency of the transmitter.</p> <p>Recommended separation distance</p> <p>$d = 1.17 \sqrt{P}$</p> <p>$d = 1.17 \sqrt{P}$ 80 MHz –800 MHz</p> <p>$d = 2.33 \sqrt{P}$ 800 MHz–2.5 GHz</p> <p>where P is the maximum output rating of the transmitter in watts (W) according to the transmitter manufacture and d is recommended separation distance in meters (m).</p> <p>Field strengths from fixed RF transmitters, as determined by an electromagnetic site survey^a, should be less than the compliance level in each frequency range^b.</p> <p>Interference may occur in the vicinity of equipment marked with the following symbol:</p> 

NOTE 1: At 80 MHz and 800 MHz, the higher frequency range applies.

NOTE 2: These guidelines may not apply in all situations. Electromagnetic propagation is affected by absorption and reflection from structures, objects and people.

Electromagnetic Immunity for Non-Life Supporting Equipment and Systems

^a Field strengths from fixed transmitters, such as base station for radio (cellular/cordless) telephones and land mobile radios, amateur radio, AM and FM radio broadcast and TV broadcast cannot be predicted theoretically with accuracy. To assess the electromagnetic environment due to fixed RF transmitters, an electromagnetic site survey should be considered. If the measured field strength in the location in which the System is used exceeds the applicable RF compliance level above, the System should be observed to verify normal operation. If abnormal performance is observed, additional measures may be necessary, such as reorienting or relocating the System.

^b Over the frequency range 150 kHz to 80 MHz, field strengths should be less than 3 v/m.

Recommended Separation Distance Between Portable and Mobile RF Communications Equipment and the System			
<p>The System is intended for use in an electromagnetic environment in which radiated RF disturbances are controlled. The customer or the user of the System can help prevent electromagnetic interference by maintaining a minimum distance between portable and mobile RF communication equipment (transmitters) and the System as recommended below, according to the maximum output of the communications equipment.</p>			
Rated Maximum Output Power of Transmitter Watts	Separation Distance According to Frequency of Transmitter		
	Meters		
	150 kHz to 80 MHz	80 MHz to 800 MHz	800 MHz to 2.5 GHz
	$d = 1.17 \sqrt{P}$	$d = 1.17 \sqrt{P}$	$d = 2.33 \sqrt{P}$
0.01	0.117	0.117	0.233
0.10	0.370	0.370	0.737
1.00	1.170	1.170	2.3300
10.00	3.700	3.700	7.3600
100.00	11.700	11.700	23.300
<p>For transmitters rated at a maximum output power not listed above, the recommended separation distance (d) in meters (m) can be estimated using the equation applicable to the frequency of the transmitter, where P is the maximum output power rating of the transmitter in watts (W) according to the transmitter manufacturer.</p> <p>NOTE 1: At 80 MHz and 800 MHz, the separation distance for the higher frequency range applies.</p> <p>NOTE 2: These guidelines may not apply in all situations. Electromagnetic propagation is affected by absorption and reflection from structures, objects and people.</p>			

Wireless

DRX-Revolution Wireless Systems

- CARESTREAM DRX-1 or DRX-1C System Detector
- DLink DAP 2553 Access Point
- CARESTREAM Grid Alignment Transmitter
- RF Ideas Model RDR-80_82AKU Proximity Badge Reader
- Code Corp. Radio Modem, Model CR2AG-R0-01-02 Bar Code Reader
- Kensington BlueTooth USB Micro Adapter, Model M01011
- Intel Centrino Ultimate N 6300 WLAN module, Model 633AN

DRX-1 and DRX-1C System Detectors

Radio Frequency Exposure Declaration—See the **DRX-Revolution Mobile X-ray System Safety and Regulatory Information** and release notes for the DRX-1 and DRX-1C System detectors.

Intentional Radiator Wireless Compliance to Regulatory Requirements—See the **DRX-Revolution Mobile X-ray System Safety and Regulatory Information** and release notes for the DRX-1 and DRX-1C detectors.

Grid Alignment Transmitter

Radio Frequency Exposure Declaration

The Grid Alignment Transmitter is a mobile wireless device according to FCC regulation 2.1091 (b). The average field strength for RF emissions from the Grid Alignment Transmitter has been measured at 162 uv/m. The RF emissions from the transmitter are well under the Maximum Permissible Exposure limits (614 uv/m) for human exposure to radio frequency radiation, according to FCC regulation 1.1310, Table 1.

Although the Grid Alignment Transmitter RF emissions are significantly below FCC limit for human exposure, the transmitter is designed to be used in such a way that a separation distance of at least 20 cm (approximately 8 in.) is normally maintained between the transmitter's radiating structure and the bodies of nearby persons (the mobile cart operators or patients). The transmitter is located on the tube head assembly (see “[Systems Label Locations](#)” on page 1-36).

Under Industry Canada regulations, this radio transmitter may only operate using an antenna of a type and maximum (or lesser) gain approved for the transmitter by Industry Canada.

To reduce potential radio interference to other users, the antenna type and its gain should be chosen so that the equivalent isotropically radiated power (e.i.r.p.) is not more than that necessary for successful communication.

Conformément à la réglementation d'Industrie Canada, le présent émetteur radio peut fonctionner avec une antenne d'un type et d'un gain maximal (ou inférieur) approuvé pour l'émetteur par Industrie Canada.

- DLink DAP 2553 Access Point
- RF Ideas Model RDR-80_82AKU Proximity Badge Reader
- Bar Code Reader (Code Corp. Radio Modem, Model CR2AG-R0-01-02)
- Kensington BlueTooth USB Micro Adapter, Model M01011
- Intel Centrino Ultimate N 6300 WLAN module, Model 633AN

Refer to the appropriate manufacturer documentation for wireless regulatory declarations.

The CARESTREAM DRX-Revolution Mobile X-ray System uses the same vendor, type, and model antennae originally certified with the Intel 6300 WLAN module and the DLink DAP 2553 Access Point.

Wireless Compliance Information for EU Directive 1999/5/IEC

Grid Alignment Intended Use

When the user obtains an X-ray image, there is generally an optimal alignment between the radiation source and the two-dimensional receptor that records the image data. In most cases, the X-ray source provides radiation in a direction that is perpendicular to the receptor. Use of an anti-scatter grid can significantly improve the quality of X-ray images. When using a grid, the requirements for good alignment are much more stringent. For mobile X-ray systems, the receptor is placed behind the patient and is blocked from the operator's view by the patient, bedding, and so forth. This makes it very difficult to align the X-ray source to the detector properly. The grid helps an operator achieve the correct alignment.

Principle of Operation

The Grid Alignment System uses transmitter emitter coils mounted on the X-ray source to produce a rotating magnetic field vector.

Magnetic field sense coils are mounted in the perimeter of a frame that holds the grid and DRX-1 detector. The signal from the emitter is seen by the sense coils. The processor on the cart interprets the signals to determine the relative alignment of the X-ray tube and the detector, and displays it on a graphical user interface.

EC Declaration of Conformity

EC Declaration of Conformity to R&TTE Directive 1999/5/EC

Manufacturer: Carestream Health, Inc.
150 Verona Street
Rochester, New York 14608
United States

EU Representative: Carestream Health, France
1, rue Galilée
93192 NOISY-LE-GRAND Cedex
France

Product: DRX-Revolution Grid Alignment Transmitter
Type Number: DRXRGA

Declaration

We, Carestream Health, declare under our own responsibility that this equipment is in compliance with the essential requirements and other relevant provisions of Directive 1999/5/EC

Wireless Standard: ETSI EN 301 489-V1.8.1
ETSI EN 300 330 Sections 7.3, 7.4, 7.5, 7.5.4

EMC Standard: EN 55022:2006 + A1:2007 (Emissions)
EN 61000-4-2:2009 (Immunity Electrostatic Discharge)
EN 61000-4-3:2006 + A1:2007 + A2:2010
(Immunity Radiated RF Electromagnetic Field)

Product Safety Standard: EN 60601-1 1990: + A1:1993 + A2:1995
EN 60601-1-1:2001

Signature: Dale B. Parks

Name: Dale B. Parks

Title: World Wide Manager EHS

Date: 01/17/2012

The Grid Alignment Transmitter may be operated in all European Union countries listed below (and other countries following the EU Directive 1999/5/EC R&TTE) without restrictions.

Austria	at	Liechtenstein	li
Belgium	be	Lithuania	lt
Bulgaria	bg	Luxembourg	lu
Cyprus	cy	Malta	mt
Czech Republic	cz	Netherlands	nl
Denmark	da	Norway	no
Estonia	ee	Poland	pl
Finland	fi	Portugal	pt
France	fr	Romania	ro
Germany	de	Slovakia	sk
Greece	el	Slovenia	sl
Hungary	hu	Spain	es
Iceland	ie	Sweden	se
Ireland	is	Switzerland	ch
Italy	it	United Kingdom	gb
Latvia	lv		

Compliance: Grid Alignment

Austria, Ireland, United Kingdom

This equipment is in compliance with the essential requirements and other relevant provisions of Directive 1999/5/EC

Belgium

Cet équipement est conforme aux exigences essentielles et autres dispositions pertinentes de la directive 1999/5/CE

E

Deze apparatuur is overeenstemming is met de essentiële eisen en andere relevante bepalingen van Richtlijn 1999/5/EG

Dieses Gerät ist in Übereinstimmung mit den grundlegenden Anforderungen und den übrigen einschlägigen Bestimmungen der Richtlinie 1999/5/EG

Bulgaria

Това оборудване е в съответствие със съществените изисквания и другите съответни разпоредби на Директива 1999/5/EC

Cyprus

Το υλικό αυτό είναι σύμφωνο με τις βασικές απαιτήσεις και άλλες σχετικές διατάξεις της οδηγίας 1999/5/EK

Bu cihaz esas şartlari ve Direktif 1999/5/EC digeri ilgili hükümleri ile uyumlu oldugunu

Czech Republic

Toto zařízení je ve shodě se základními požadavky a dalšími příslušnými ustanoveními směrnice 1999/5/ES

Denmark

Denne udstyr er i overensstemmelse med de væsentlige krav og øvrige relevante bestemmelser i direktiv 1999/5/EF

Estonia

Nimetatud seadmed on kooskõlas olulisel nõudeid ja muid asjakohaseid sätteid direktiivi 1999/5/EÜ

Finland

Tämä laite on olennaisten vaatimusten noudattaminen ja muiden asiaa koskevien säännösten direktiivin 1999/5/EY

France

Cet équipement est conforme aux exigences essentielles et autres dispositions pertinentes de la directive 1999/5/CE

Germany

Dieses Gerät ist in Übereinstimmung mit den grundlegenden Anforderungen und den übrigen einschlägigen Bestimmungen der Richtlinie 1999/5/EG

Greece

Το υλικό αυτό είναι σύμφωνο με τις βασικές απαιτήσεις και άλλες σχετικές διατάξεις της οδηγίας 1999/5/EK

Hungary

Ez a készülék megfelel az alapvető követelményeknek és más vonatkozó 1999/5/EK irányelv rendelkezéseit

Iceland

Þetta tæki er samkvæmt grunnkröfum og öorum viðeigandi akvaeoum Tilskipunar 1999/5/EC

Italy

Questa apparecchiatura è conforme ai requisiti essenziali ed alle altre disposizioni pertinenti della direttiva 1999/5/CE

Latvia

Latvian: Šī iekārta ir atbilstību būtiskajām prasībām un citiem attiecīgajiem noteikumiem Direktīva 1999/5/EK

Liechtenstein

Dieses Gerät ist in Übereinstimmung mit den grundlegenden Anforderungen und den übrigen einschlägigen Bestimmungen der Richtlinie 1999/5/EG

Lithuania

Ši įranga yra laikomasi esminių reikalavimų ir kitu atitinkamu Direktyvos 1999/5/EB nuostatu

Luxembourg

Cet équipement est conforme aux exigences essentielles et autres dispositions pertinentes de la directive 1999/5/CE

Dieses Gerät ist in Übereinstimmung mit den grundlegenden Anforderungen und den übrigen einschlägigen Bestimmungen der Richtlinie 1999/5/EG

Malta

Dan it-tagħmir ikun konformi mar-reqwiziti essenzjali u dispozizzjonijiet oħra rilevanti tad-Direttiva 1999/5/KE

Netherlands

Deze apparatuur is overeenstemming is met de essentiële eisen en andere relevante bepalingen van Richtlijn 1999/5/EG

Norway

dette utstyret er i samsvar med de grunnleggende krav og øvrige relevante bestemmelser i direktiv 1999/5/EF.

Poland

Sprzet ten jest zgodny z zasadniczymi wymogami oraz pozostałymi stosownymi postanowieniami Dyrektywy 1999/5/WE

Portugal

Este equipamento está em conformidade com os requisitos essenciais e outras disposições relevantes da Directiva 1999/5/CE

Romania

Acest echipament este în conformitate cu cerintele esentiale si alte prevederi relevante ale Directivei 1999/5/CE

Slovakia

Toto zariadenie je v zhode so základnými požiadavkami a ďalšími príslušnými ustanoveniami smernice 1999/5/ES

Slovenia

Ta oprema je v skladu z bistvenimi zahtevami in drugimi ustreznimi določbami Direktive 1999/5/ES

Spain

Este equipo se encuentra en cumplimiento de los requisitos esenciales y otras disposiciones pertinentes de la Directiva 1999/5/CE

Sweden

Denna utrustning är i överensstämmelse med de grundläggande kraven och andra relevanta bestämmelser i direktiv 1999/5/EG

Switzerland

Dieses Gerät ist in Übereinstimmung mit den grundlegenden Anforderungen und den übrigen einschlägigen Bestimmungen der Richtlinie 1999/5/EG

Cet équipement est conforme aux exigences essentielles et autres dispositions pertinentes de la directive 1999/5/CE

Questa apparecchiatura è conforme ai requisiti essenziali ed alle altre disposizioni pertinenti della direttiva 1999/5/CE

National Usage Restrictions

NOTE: There are no restrictions on operation of the Grid Alignment Transmitter in the countries listed above.

Refer to the appropriate manufacturer documentation for European Union wireless regulatory declarations for the following products:

- RF Ideas Model RDR–80_82AKU Proximity Badge Reader
- Bar Code Reader (Code Corp. Radio Modem, Model CR2AG–R0–01–02)
- Kensington BlueTooth USB Micro Adapter, Model M01011
- Intel Centrino Ultimate N 6300 WLAN module, Model 633AN

Collision Sensing Feature

Drive System	
Motor Drive	Two independent drive motors provide forward/reverse drive and directional control.
Collision Sensing	Frontal and Lateral
Maximum Drive Speed	Up to 5.6 km/h (3.5 mph)

Patient Vicinity

CAUTION:
 The barcode reader charger cannot be placed in the patient vicinity.

The patient vicinity is defined as follows:

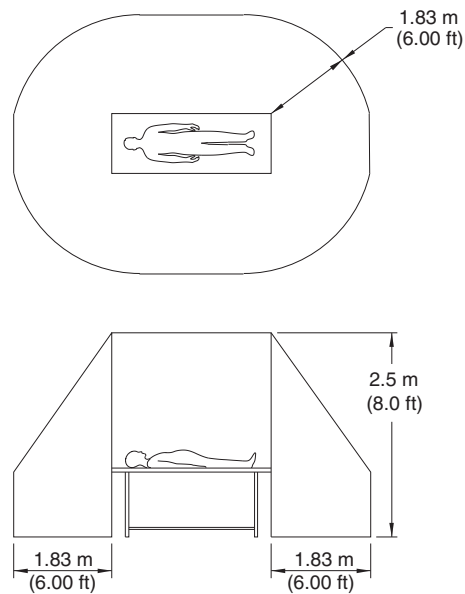

H196_0004GC

X-ray Tube and Collimator

X-ray Tube

- VARIAN Diamond housing with a RAD 68 insert
- Inherent Filtration = 0.7 mm Al

Collimator

- Ralco R108
- Inherent filtration = 2.0 mm AL

Accessories

The following items are accessories for the System:

- CARESTREAM DRX-1 or DRX-1C System Detector
- CARESTREAM Grid Holder+
- 2D Barcode Reader
- Infrared remote prep/exposure switch
- Dose Area Product meter

Flammability

The System is not suitable for use in the presence of a flammable anesthetic mixture with oxygen or nitrous oxide.

IMPORTANT: *Instructions are provided to indicate the type of attachment plug that should be used for connection to the alternate voltage.*

Method of Cleaning

See the *DRX-Revolution Mobile X-ray System Hardware Guide* for instructions on cleaning the equipment.

Extra Focal Dimensions

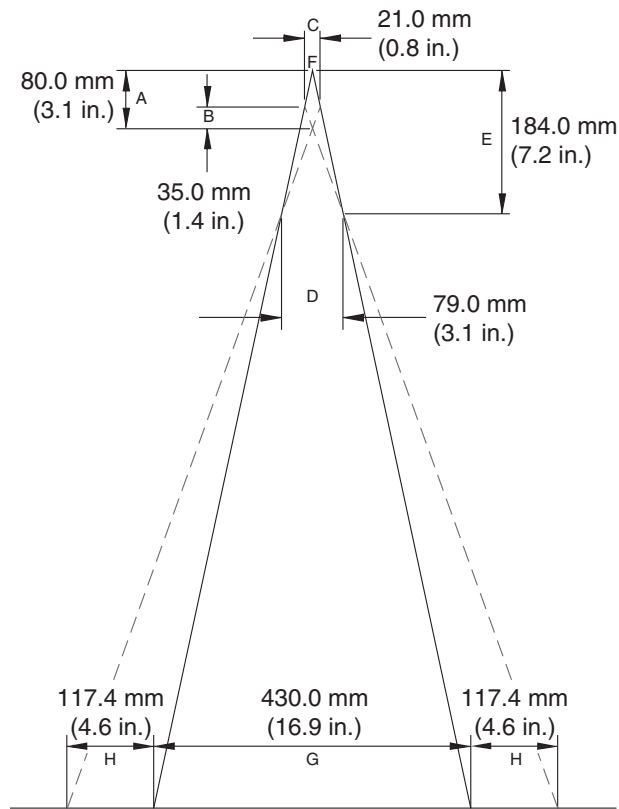

Key:

A	Distance from the focal spot to the collimator mounting flange surface
B	Distance from the near-focus shutter opening to the mounting flange surface
C	The maximum opening size of near-focus shutters
D	The maximum size of far-focus shutters
E	The distance from the focal spot to the far-focus shutters
F	Focal spot position
G	Primary X-ray field
H	Extra focal radiation

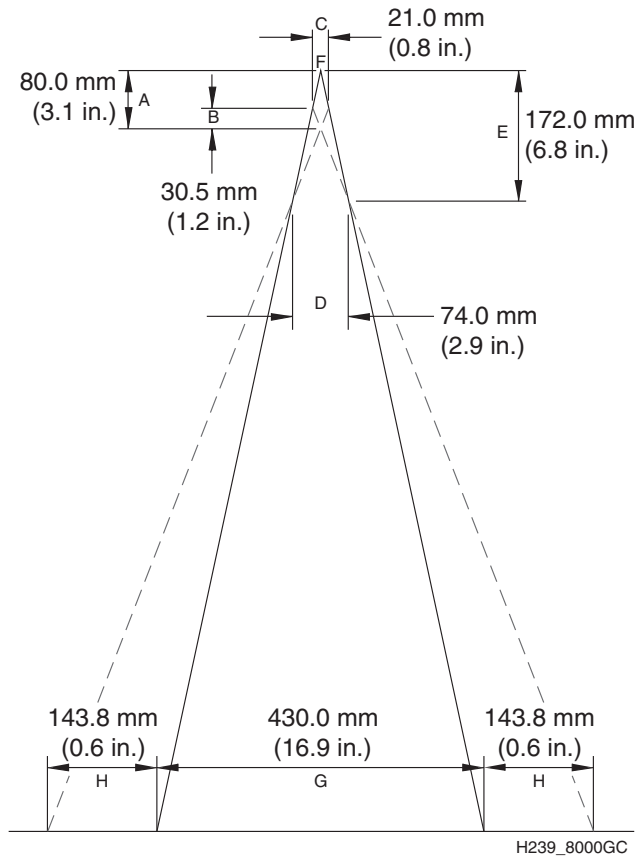

Key:

A	Distance from the focal spot to the collimator mounting flange surface
B	Distance from the near-focus shutter opening to the mounting flange surface
C	The maximum opening size the of near-focus shutters
D	Maximum size of the far-focus shutters
E	Distance from the focal spot to the far-focus shutters
F	Focal spot position
G	Primary X-ray field
H	Extra focal radiation

Labels

Systems Label Locations

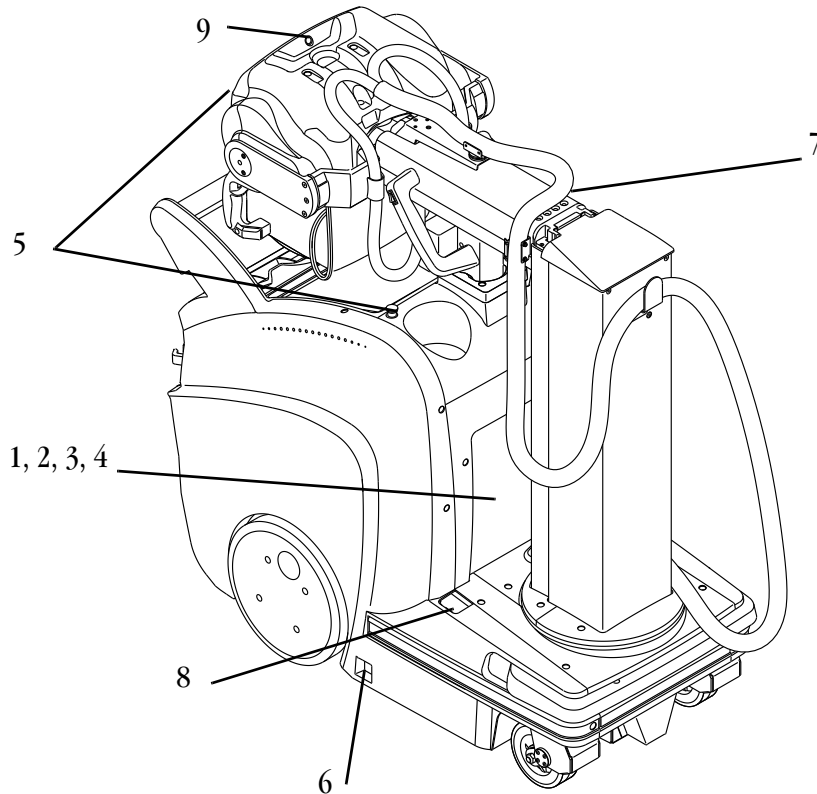

- 1 System Data Plate
- 2 Generator label
- 3 X-ray tube label
- 4 Collimator label
- 5 Emergency Stop label (2)
- 6. AC voltage circuit breaker label (The DC voltage circuit breaker label is in the same location on the opposite side.)
- 7. Transport position warning label
- 8. Retractable power cord
- 9. Ionizing radiation label

NOTE: The label locations as shown display the external labels with pertinent information from the manufacturers.

System Data Plate Sample

Official Product Name (English)		1
Official Product Name (Japanese, if required)		
Official Product Name (Chinese, if required)		
SC	SN	2
Manufactured:		3
MODEL	型号:	4
		5
		6
注册证号:		7
注册标准:		8
THIS PRODUCT COMPLIES WITH 21 CFR CHAPTER 1, SUBCHAPTER J		9
11	Made in China by Carestream Health, Inc. 150 Verona Street, Rochester, NY 14608 锐珂(上海)医疗器械有限公司 上海市浦东新区金桥出口加工区 川桥路1510号第四、七幢通用厂房 中国制造	10

Area No.	Description
1	Official product name
2	Service code and serial number
3	Manufactured date
4	Model type as required / consistent with product safety test reports
5	Voltage range, rated frequency in hertz and amps / consistent with product safety test reports: V = volts, Hz = hertz, A = amperes
6	Symbols for product safety, EMC, and CE marking
7	SFDA Registration number
8	SFDA Product Standard number
9	Compliance statement according to FDA requirements for radiation emitting products.
10	Label manufacturer registration number and material specification
11	Manufacturer

Detector /Grid Holder Weight Limit Label



CAUTION:

Since the detector/grid is not a patient support device, it must be placed on a suitable surface, such as a table or a floor, before applying patient weight. The weight label indicates the acceptable limits of use that will not damage the detector. To prolong the life of the detector, and minimize potential internal detector damage, observe the following weight restrictions:

- The maximum concentrated weight over a small area of the detector/grid surface (50 mm diameter) must not exceed 23 kg (50 lb).
- The maximum distributed weight applied uniformly over the entire detector/grid surface is 125 kg (275 lb).

Product Disclosure Table

Product Disclosure Table
有毒有害物质或元素名称及含量标识表
Table of hazardous substances' name and concentration

部件名称 Component name	有毒有害物质或元素 hazardous substances' name					
	铅 (Pb)	汞 (Hg)	镉 (Cd)	六价铬 (Cr6+)	多溴联苯 (PBB)	多溴二苯醚 (PBDE)
检测器 (Detector)	X	O	O	O	O	O
X 射线管 (X-ray Tube)	X	O	O	O	O	O
电路板 (Circuit Board)	X	O	O	O	O	O
准直仪 (Collimator)	X	O	O	O	O	O
X 射线高压发生器 (X-ray Generator)	X	O	O	X	O	O
<p>o: 该有毒有害物质在该部件所有均质材料中的含量均在 SJ/T 11363-2006 规定的限量要求以下。 x: 该有毒有害物质至少在该部件的某一均质材料中的含量超出 SJ/T 11363-2006 规定的限量要求。 o indicates hazardous substance concentration lower than MCV x: indicates hazardous substance concentration higher than MCV</p> <p style="text-align: center;"></p> <p>环保使用期限 (EPUP) 在中国大陆, 该值表示电子信息产品中含有的有毒有害物质或元素在正常使用的条件下不会发生外泄或突变, 用户使用此产品不会对环境造成严重污染或对人身、财产造成严重损害的期限 (以年计)。 该值根据操作说明中所规定的产品正常使用条件而定。</p> <p>Environmental Protection Use Period (EPUP) In China mainland, this number indicates the time period (calculated by year) within which any hazardous substances present in the product are not expected to be released such that there is risk to human health, property, or the environment. This value is assigned based on normal use of the product as described in the operating instructions. This value is assigned based on normal use of the product as described in the operating instructions.</p>						

H239_0017DA

DRX-Revolution kV & mAs Selection Table

kV Selection	mAs Selection									
	400 mA [5]	320 mA [5]	250 mA [5]	180 mA [5]	150 mA [5]	120 mA [5]	100 mA [5]	50 mA [5]		
40-49	[3]		0.5-36 mAs	0.36-0.45 [1] 40-320 mAs	0.32 [1]	0.25-0.28 [1]	0.20-0.22 [1]	0.10-0.18 [1]		
50-59	[3]		0.5-36 mAs	0.36-0.45 [1] 40-320 mAs	0.32 [1]	0.25-0.28 [1]	0.20-0.22 [1]	0.10-0.18 [1]		
60-69	[3]	0.71-10 mAs	0.5-0.63 [1] 11-22 mAs	0.36-0.45 [1] 25 mAs	0.32 [1] 28-220 mAs	0.25-0.28 [1] 250-320 mAs	0.20-0.22 [1]	0.10-0.18 [1]		
70-79	0.80-9 mAs	0.71 [1] 10 mAs	0.5-0.63 [1] 11 mAs	0.36-0.45 [1] 12.5-22.0 mAs	0.32 [1] 25-71 mAs	0.25-0.28 [1] 80-320 mAs	0.20-0.22 [1]	0.10-0.18 [1]		
80-89	[4]	0.71-8 mAs	0.5-0.63 [1] 9 mAs	0.36-0.45 [1] 10-18 mAs	0.32 [1] 20-50 mAs	0.25-0.28 [1] 56-320 mAs	0.20-0.22 [1]	0.10-0.18 [1]		
90-99	[4]	0.71-7.1 mAs	0.50-0.63 [1] 8 mAs	0.36-0.45 [1] 9.0 mAs	0.32 [1] 10-18 mAs	0.25-0.28 [1] 20-320 mAs	0.20-0.22 [1]	0.10-0.18 [1]		
100-109	[4]		0.50-7.1 mAs	0.36-0.45 [1] 8.0 mAs	0.32 [1] 9-18 mAs	0.25-0.28 [1] 20-320 mAs	0.20-0.22 [1]	0.10-0.18 [1]		
110-119	[4]		0.50-5.6 mAs	0.36-0.45 [1] 6.3 mAs	0.32 [1] 7.1 mAs	0.25-0.28 [1]	0.20-0.22 [1] 8-280 mAs	0.10-0.18 [1]		
120-129	[4]		0.50-5 mAs [2]	0.36-0.45 [1] 5.60 mAs	0.32 [1] 6.30 mAs	0.25-0.28 [1]	0.20-0.22 [1] 7.1-280 mAs	0.10-0.18 [1]		
130-139		[4]		0.36-4.50 mAs	0.32 [1] 5.00 mAs	0.25-0.28 [1]	0.20-0.22 [1] 5.6-280 mAs	0.10-0.18 [1]		
140-149		[4]		0.36-4.50 mAs	0.32 [1] 5.00 mAs	0.25-0.28 [1]	0.20-0.22 [1] 5.6-280 mAs	0.10-0.18 [1]		
150		[4]		0.36-4.00 mAs	0.32 [1] 4.50 mAs	0.25-0.28 [1]	0.20-0.22 [1] 5.0-280 mAs	0.10-0.18 [1]		

[1] The mA is to be reduced so that the minimum exposure time is 2 ms.

[2] Indicates that the maximum nominal power is 32.25 kW at 129.00 kV when it is in the range of 0.5 to 5.0 mAs.

[3] The X-ray tube emission is limited.

[4] The value exceeds the maximum power out capability of the generator.

[5] The mA is not user selectable.



Carestream Health, Inc.
150 Verona Street
Rochester, New York 14608
United States

© Carestream Health, Inc. 2012

CARESTREAM is a trademark of Carestream Health, Inc.

9J0239

Printed in the United States