



Installation & User's Manual

Trailblazer Digital Radio 2011

TB 5.9

Part Number 490-2000
Rev 1.03
Copyright 2011

Trademark Information

Trailblazer, the Trailblazer logo, RuralConnect, and the RuralConnect logo are registered trademarks of Carlson Wireless Technologies Inc. Windows is a registered trademark of Microsoft Corporation.

Copyright

Copyright © 2002-2011 Carlson Wireless, Inc. All Rights Reserved. No part of this manual may be reproduced without permission from Carlson Wireless Technologies. The information contained in this publication is the latest available; however, Carlson Wireless Technologies reserves the right to make changes without notice.

US Headquarters:

1385 8th Street
Arcata, CA 95521 USA

Presales Inquires and Applications Support

Please contact your local distributor or the Carlson Wireless sales department. Purchasers of Carlson Wireless Technologies products should make their own evaluations to determine the suitability of each such product for their specific application. Carlson Wireless Technologies obligations regarding the use or application of its products shall be limited to those commitments to the purchaser set forth in its Standard Terms and Conditions of Sale for a delivered product. The use of this manual is also limited to the terms and conditions stated in the contract between CWT and the purchaser.

Tel: +1 707.822.7000

Fax: +1 707.822.7010

Email: sales@carlsonwireless.com

URL: <http://www.carlsonwireless.com>

Repair and Return

Carlson Wireless will replace or repair this product within one year from the date of shipment if it does not meet its published specification, or if it fails while in service. A return material authorization (RMA) is required prior to returning equipment to CWT.

Customer Service

Technical support is available Monday - Friday, 9:00 am to 4:30 pm, PDT.

Tel: +1 707.822.7000

Email: support@carlsonwireless.com

URL: <http://www.carlsonwireless.com/support.html>

Training

The Customer Service department offers training classes including overviews on: applications, engineering, in-house testing, configuration, field testing and maintenance. Please contact our Customer Service department for more specific details.

SAFETY WARNING

Potentially hazardous voltages exist on TELCO lines and associated equipment. Always observe standard safety precautions during installation, operation, and maintenance of these products. To avoid the possibility of electric shock, be sure to disconnect the power from the remote power source before you perform any line connections or repairs. Always disconnect all the cables connected to the system before disconnecting the grounding connection. After disconnecting the power allow a few seconds for the internal capacitances to discharge before accessing the boards.

QUALIFIED PERSONNEL WARNING

The installation procedures described in this manual must be performed by qualified personnel aware of the hazards involved. The personnel involved in equipment installation must be trained in the installation of telephone equipment and associated power systems; these personnel must strictly observe all the safety precautions related to the installation of communication equipment.

Never install, remove, or adjust equipment and associated cables. Do not work on roofs, masts, or towers during a lightning storm.

ATTENTION! STATIC SENSITIVE DEVICES

PROPER HANDLING AND GROUNDING WARNING

Components within the Trailblazer system are sensitive to electrostatic discharge (ESD). To avoid and prevent ESD damage and device failure maintain proper grounding during configuration, repair or maintenance. This is achieved through the use of an antistatic wrist strap securely connected to chassis ground. Do not use conductive tools for adjusting channel select switch.

UL INSTALLATION SAFETY INSTRUCTIONS

- Never install telephone wiring during a lightning storm.
- Never install telephone jacks in a wet location unless the jack is specifically designed for wet locations.
- Never touch telephone wires or terminals unless the telephone line has been disconnected at the network interface.
- Use caution when installing or modifying telephone lines.

Connection to the Telephone Network

The equipment complies with Part 68 of the FCC rules. You will find the label located on the device. This label contains the FCC Registration Number and the Ringer Equivalence Number (REN) for this equipment. You must, upon request, provide this information to your telephone company. The REN is used to determine the quantity of devices that may be connected to the telephone line and still have all of those devices ring with an incoming call signal. In most areas the sum of the RENs of all devices connected to one line should not exceed five (5.0). Confirm the number of devices possible on the telephone line (in REN) by contacting the local telephone company who provides the service.

Incidence of Harm

If your telephone equipment causes harm to the telephone network, the telephone company may disconnect your service temporarily. When possible, the telephone company will notify you in advance. If advanced notice is not practical, you will be notified as soon as possible. You will also be informed of your right to file a complaint with the FCC.

Rights of the Telephone Company

Your telephone company may make changes in its facilities, equipment, operations or procedures that could affect the proper functioning of your equipment. In this case, you will be notified in advance to give you an opportunity to maintain uninterrupted telephone service.

Coin Service or Party Use Line

This equipment may not be used on the coin service provided by the telephone company. Connection to party lines is subject to state tariffs.

Compliance and US Regulatory Information

Model TB 5.9

FCC Reg No., Part 68

FCC Reg No., Part 15

Industry Canada CS-03

Industry Canada RSS-210

BMD8 USA – 27773-PT-E

FCCID: OPA-TB59

3448A-10241A

3448A-TB59

Compliance Classification

This equipment has been tested and found to comply with the limits for a Class A digital device, pursuant to part 15 of the FCC Rules. These limits are designed to provide reasonable protection against harmful interference when the equipment is operated in a commercial environment. This equipment generates, uses, and can radiate radio frequency energy and, if not installed and used in accordance with the instruction manual, may cause harmful interference to radio communications. Operation of this equipment in a residential area is likely to cause harmful interference in which case the user will be required to correct the interference at his own expense.

Radio Interference: Carlson Wireless USA Model TB59

This device complies with Part 15 of the FCC Rules. Operation is subject to the following two conditions:

- (1) This device may not cause harmful interference, and
- (2) This device must accept any interference received, including interference that may cause undesired operation. Changes of modification not expressly approved by the party responsible for compliance could void the user's authority to operate the equipment.

Declaration of Conformity

Manufacturer's Name: Carlson Wireless Technologies Inc.
Manufacturer's Address: 1385 8th Street
Arcata, CA 95521
USA

Declares that the product:
Product Name: **Trailblazer TB59**

Conforms to the following standard(s) or other normative document(s):
EMC:

FCC Part 90

Supplementary Information:
Published Specifications

Chris Spoerle
Director of Quality Management
1385 8th Street
Arcata, CA
Jan 2011

Table of Contents

1	Introduction.....	1
1.1	Scope of Manual.....	1
1.2	Functional Overview and Applications.....	1
1.2.1	Main Features and Advantages.....	1
1.2.2	General Specifications.....	3
2	Pretest and System Planning	3
2.1	Site Requirements and System Planning	4
2.1.1	Grounding.....	4
2.1.2	Lightning Protection.....	4
2.1.3	Line of Sight: Is it enough?	4
2.1.4	Fresnel Zone: What it is in plain English!.....	5
2.1.5	Path Loss	6
2.1.6	RF Cable Sizing and Recommendations.....	6
2.1.7	Data Cable Recommendations.....	7
2.1.8	General Tools	7
2.2	Unpacking.....	8
2.3	Bench Testing Instructions	9
2.3.1	Setting up Your Trailblazer on the Bench	9
2.3.2	Powering the Trailblazer.....	9
2.3.3	Connecting the POTS Lines	11
2.3.4	Connecting the Leased Lines	12
3	Operation.....	15
3.1	Configuring and Accessing the Trailblazer Unit	15
3.1.1	Connecting the Serial Cable.....	15
3.1.2	Installing the CWT GUI on Your PC	15
3.1.3	Using the GUI.....	15
3.1.4	Software Downloads Using the GUI	16
3.2	Accessing the Trailblazer using HyperTerminal™	18
3.2.1	Windows™ HyperTerminal™ Software	18
3.3	Setting the Radio Frequency and Scrambling Code.....	18
3.3.1	Selecting the CPE Time Slot	19
3.4	Allocating Bandwidth to Voice and/or Data.....	19
4	Field Installation Options.....	23
4.1	Mounting the Enclosure.....	23
4.2	External Antennas	24
4.2.1	Marketing and Sales Channels.....	25
4.2.2	Calculating the EIRP of an External Antenna	25
4.2.3	RF Safety Hazard Warning.....	26
4.3	16dBi 5.8 - 5.9 GHz Sector Base-Station Antenna.....	27
4.3.1	Product Overview	27
4.3.2	Unpacking	27

4.3.3	Mounting.....	27
4.4	Weatherproofing RF Connections	30
4.5	Antenna Alignment	30
4.6	Interference Solutions.....	30
4.7	Lightning Protection.....	31
4.7.1	Antenna Port Protection	31
4.7.2	Telephone Line Port/ Subscriber Premises Protection	34
5	Test & Maintenance	36
5.1	Diagnostics	36
5.1.1	LED Function.....	36
5.2	Maintenance	37
5.2.1	Installation of Software/Firmware Upgrades.....	37
6	Appendix	38
6.1	About Carlson Wireless	38
6.1.1	Mission	38
6.1.2	History	38
6.1.3	Summary	38
6.2	System Specifications.....	39
6.2.1	Block Diagram	40
6.3	Cable Pin outs	41
6.3.1	Configuration Port Pinout	41
6.4	Advanced Programming and Diagnostics.....	43
6.4.1	Configuring the Serial Port Parameters	43
6.4.2	Setting the V35 enable and port location.....	44
6.4.3	Received Signal Strength Indicator (RSSI).....	44
6.4.4	Air Link Quality	45
6.4.5	Installation of Software/Firmware Upgrades.....	45
6.5	Antenna Patterns and Specifications.....	47
6.5.1	16dBi Directional Panel Plots and Specs	47
6.6	Warranty	48
6.7	Acronyms/Abbreviations	49
6.8	Glossary	50

List of Figures

Figure 1: Line of Sight is clear, the first Fresnel Zone is NOT clear.....	5
Figure 2: Base Unit Power Connections	10
Figure 3: Connecting the Serial Cable	15
Figure 4: Rotary Switch and Reset Button	18
Figure 5: CPE Time Slot Selection Switch	19
Figure 6: Wall mounting the Trailblazer enclosure	23
Figure 7: Pole mounting the Trailblazer enclosure	24
Figure 8: Surge Protection, RF	32
Figure 9: Antenna Port Lightning Protector, VSWR and Insertion Loss	33
Figure 10: Primary Telephone Line Transient Protection	34
Figure 11: Trailblazer Radio Card LEDs	36
Figure 12: Block Diagram of Radio Card	40
Figure 13: Serial Data Cable Pinout (PCB View)	41
Figure 14: Serial Data Cable Schematic	42

List of Tables

Table 1: Fresnel Zone Chart	5
Table 2: Fade Margin Chart	6
Table 3: Coax Cable Loss Table.....	7
Table 4: Feed Cable Sizing and Distance for the Traiblazer	11
Table 10: Commands and switches for bandwidth.....	20
Table 11: Example configuration scripts	22
Table 12: RF Lightning Protection.....	32
Table 13: Subscriber side protection.....	35
Table 14: System Status LED Information Table	36
Table 15: Configuration Port Cable Construction Table.....	41
Table 16: Serial Data Cable Pinout.....	42
Table 17: 16dBi Directional Panel Specifications.....	47

1 Introduction

1.1 Scope of Manual

The purpose of this manual is to provide planning and installation personnel with the appropriate procedures to plan and install the 2011 Trailblazer Digital Microwave Radio and accessory equipments. In order to avoid harm to persons or damage to the product, please ensure that you have read and understand the safety, unpacking, and installation sections before proceeding.

1.2 Functional Overview and Applications

Using state-of-the-art digital electronics, the Trailblazer provides 512kbps of high-quality, reliable, wireless voice and/or high-speed data connection over distances of up to 32mi/ 50 km or more in repeated applications. This radio integrates seamlessly with POTS voice cards and Leased Line cards, V.35 protocol or standard 10baseT Ethernet devices. CWT provides competitive price and performance solutions for many of the world's telecommunication needs in both point-to-point and point-to-multipoint applications. Applications include:

- Security Monitoring Cameras
- Public Safety Data Links
- Internet Cafés and Telephone Calling Centers
- Point-to-Point Commercial Data Links
- Cellular Backhaul Data Needs
- Permanent or Temporary Telephone Service
- Temporary or Emergency Restoration of Service
- Public Calling Phones
- Retrofit for Exhausted Wire line Systems
- Islands and other Isolated Areas
- Inaccessible, Environmentally Sensitive and Historic Areas
- Harsh Climates and Geologically Adverse Environments

1.2.1 Main Features and Advantages

Advantages Over Wire Line

The Trailblazer's wireless link eliminates the expense of right-of-way and wire line costs, provides solutions for areas where adverse geology, climate or inaccessibility exclude the installation of wire lines, and preserves the beauty and integrity of sensitive environments and historic structures.

Wire Line Quality Voice and Data

You can configure your Trailblazer for data speeds up to 512 kbps or designate part of your bandwidth to POTS lines, as the Trailblazer seamlessly integrates our 64kbps full

bandwidth PCM POTS or Leased Line cards for high quality, uncompressed audio with an excellent signal-to-noise ratio.

Easy Installation

The units mount on a 1.5"- 3" pipe or pole or to any vertical surface, use an external antenna, and have their own power supply (optional) or operate on 12-24 VDC, easily powered by solar.

Low Power Draw: Ideal for Solar Applications

The low power consumption of 2 Watts makes the units very energy efficient. They accept any DC voltage from 12V to 24V and are thus easily powered by solar. CWT solar powering kits are available with up to 7 days of back-up power.

Flexible & Programmable

All Trailblazer models are bench or field programmable. Using the GUI (Graphical User Interface) application with a Windows PC and serial COM port, you can configure the amount of bandwidth, allocate voice and data channels, select different frequencies and CDMA codes, use antenna alignment aids and other diagnostic tools, as well as upgrade software and firmware. The Trailblazer models support all CLASS features, fax, and V.90 dial-up modems.

Rugged & Weatherproof

All components, including the digital radio cards, multiplexer, power supplies & CPU, are fully integrated into the 8lb/ 3kg waterproof enclosure. The units are housed in a NEMA 4X waterproof enclosure, built to last in tough climates. The lockable polycarbonate enclosure with a neoprene gasket will protect against wind, rain, and ice ensuring years of service.

License Required for the 5.9 MHz

The Trailblazer TB 5.9 uses the, in most countries, the license 5.9 GHz frequency bands, while fully encrypted spread-spectrum CDMA modulations, proprietary framing structure and packet size assure complete privacy and security.

Standard ISO 2593 V.35 DTE port

Because the Trailblazer models feature a standard ISO 2593 V.35 DTE port, most other V.35 devices plug right into the Trailblazer Phone Extender.

Repeater Mode

This product can be used as a digital repeater by simply connecting two units via the V.35 data port and optional repeater cable.

Expandable

Starting with only one link, you can add CPE units, gaining the features of a point-to-multipoint topology for your current and future growing needs without losing any of your original investment.

10BaseT On-Board Ethernet Port

On-board Ethernet satisfies simultaneous LAN / IP data and PCM voice needs with an Industry Standard RJ45 10BaseT connection. Some of its advanced features include 802.3 Ethernet supported by Transparent LAN bridging and Automatic LAN MAC address filtering at the MAC level, making it transparent to higher level protocols such as TCP/IP, DECnet, NETBIOS, and IPX network protocols. Broadcast, multicast, or frames set up for peered LAN are forwarded while reserving maximum RF bandwidth.

1.2.2 General Specifications

Note: More technical details are found in the Appendix of this manual

Product Description	Digital Microwave Radio with POTS, Leased Lines and 10BaseT / V.35 port
Data Interfaces	
Primary Serial Data Port	(1) RJ45 port providing 10BaseT
Data Rate and Type	256/512 kbps, synchronous
Serial Command Port	RS 232, 57.6 kbps, N, 8, 1, No flow, Echo on
Latency	< 4.4ms depending on speed selected
Power Requirements	
Input Voltage	12 to 24 VDC or 100-260 VAC with AC power supply (optional)
Power Consumption	2 Watts (not including add-on cards)
Battery Backup (optional)	Up to 8 hours with a 2.2mAh SLA battery.
RF Specifications	
RF Frequency Range	5.865 to 5.885Ghz, 5.895 to 5915Ghz
Modulation Type	BPSK (256) or QPSK (512kbs) DSSS
Transmitter Output Power	+20dBm max, auto set for CDMA operation
Receiver Sensitivity (10 ⁻⁶ BER)	-93dBm @ 256 kbps, -90dBm @ 512 kbps
Operating Temp	-30 to +60 Degrees C with solar shielding, 0-90% Non-Condensing
Physical Characteristics	
Enclosure Dimensions	13 x 11 x 6 in / 33 x 28 x 15 cm
Unit Weight	8 lbs / 3.7kg
Enclosure Specifications	NEMA 4X, rain, wind and ice protected GE Valox99 [®] polycarbonate w/ neoprene gasket
Mounting	1"-2.25" or 2.5cm-5.7cm pipe/pole

2 Pretest and System Planning

2.1 Site Requirements and System Planning

2.1.1 Grounding

A ground is a low impedance electrical connection to earth that is used to dissipate energy. Grounding your Trailblazer is very important for safety reasons as well as to protect your system from damage due to lightning and static charge build up. Since lightning strikes and surges follow the path of least resistance, all ground wires must be as short and straight as possible and not be coiled or looped. Choose the largest diameter ground wire your ground connectors will accept for good electrical conductivity.

Recommended grounds are: the utility company ground, a ground rod, well casings, and cold water pipes that are of continuous metal. A note of caution: sometimes the metal-cold water pipes are repaired and/or extended with PVC piping hidden behind drywall. The introduction of PVC material disrupts the material's conductivity and thus renders it unacceptable as a ground.

Unacceptable grounds are: sprinkler pipes, PVC pipes, conduit, buried wire, and any ground that cannot be verified.

2.1.2 Lightning Protection

Lightning protection with a poor ground is the same as having no protection at all!

Lightning is one of the most dangerous and unfortunately most frequently encountered natural hazards to your Trailblazer. Ensure that your system is adequately protected. A good connection to ground is indispensable for your lightning protection to work correctly and thus preventing lightning and surge damage to your Trailblazer. The Trailblazer system is equipped with on-board **secondary active lightning protection** only. The lightning protection is only effective when the system is powered up. If you power down your Trailblazer, disconnect the antennas and phone lines to prevent damage from lightning strikes. Install **primary lightning protection** with a good ground on all RF, data/voice line connections that have even a moderate outdoor line build out. A good rule of thumb is that all lines entering or exiting a building need protection. Both ends of the cables between buildings must be protected! See section 5.2 for detailed specifications and usage information on primary lightning protection available from Carlson Wireless.

2.1.3 Line of Sight: Is it enough?

Visual line of sight (LOS) is the straight, unobstructed line between the Base unit's antenna and the CPE's antenna. In other words, when you stand next to one antenna, you can see the other one. Because RF waves spread out three dimensionally rather than in a straight line, LOS is important in microwave transmission but **not adequate**. As the waves travel out from the transmitting antenna, the signal density decreases and more three dimensional space around the visual LOS is necessary to be able to receive

a reasonable signal at the receiving antenna. This three dimensional space is called the RF LOS or Fresnel zone for the French physicist who first discovered its importance.

2.1.4 Fresnel Zone: What it is in plain English!

The Fresnel zone is the tree dimensional cone around the line-of-sight that radio waves spread out into after they leave the antenna. The cross section of the first Fresnel zone is circular; subsequent zones' cross sections are annular. The signal strength is strongest in zone 1 and decreases in each successive zone.

Not only trees, buildings and mountains can occupy a Fresnel Zone, the curvature of the earth, even for some short paths, also has to be taken into consideration. A rule of thumb is that **60% of the first Fresnel zone must be free of any obstructions for tolerable attenuation of the signal.**

In addition to absorbing the RF signal, objects in the RF path can also reflect it, making the signal out of phase with the original signal, and effectively causing signal cancellation. In zone 1 the signal will be 0 to 90° out of phase in zone 2, 90 to 270° in zone 3, 270 to 450° and so on. Even numbered zones have the maximum phase canceling effect and in odd numbered zones the reflected waves will add to the signal.

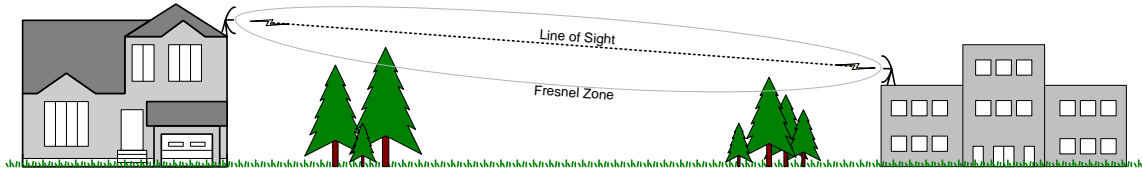

Figure 1: Line of Sight is clear, the first Fresnel Zone is NOT clear.

Zone	Frequency (MHz)	Wavelength (feet)	Distance to start		Distance to end		Fresnel Radius		60% of Zone	
			(miles)	(km)	(miles)	(km)	(feet)	(m)	(feet)	(m)
1	2400	0.41	2.0	3.2	2.0	3.2	46.53	14.18	27.92	8.51
2	2400	0.41	2.0	3.2	2.0	3.2	65.80	20.06	39.48	12.03
1	2400	0.41	1.5	2.4	4.5	7.2	49.35	15.04	29.61	9.03
1	2400	0.41	3.0	4.8	3.0	4.8	56.98	17.37	34.19	10.42
1	2400	0.41	4.0	6.4	10.0	16.0	78.65	23.97	47.19	14.38
1	2400	0.41	6.0	9.6	6.0	9.6	80.59	24.56	48.35	14.74
1	2400	0.41	12.0	19.2	12.0	19.2	113.97	34.74	68.38	20.84

Table 1: Fresnel Zone Chart

Some examples are given in the table above. On the software CD that comes with each system there is a folder called “Calculators”. In that folder you will find an excel spreadsheet called *fresnel zone calculator.xls* you can use to calculate your own path.

Set the Fresnel zone to even numbered values when plotting a profile to see potential areas of phase canceling present in the path. You can improve your path by optimizing the height of antennas so that the first Fresnel zone is clear.

2.1.5 Path Loss

After confirming line of sight and adequate Fresnel zone clearance, add the Free Space Loss of the radio signal, RF cable losses, and antenna gains to determine your system’s remaining signal, i.e. fade margin. The chart below shows various antenna and distance combinations.

<i>Distance in miles</i>	<i>Distance in km</i>	<i>Ant Gain in dBi</i>	<i>Ext RF Cable(s)</i>	<i>Path Loss in dB</i>	<i>RF power in dBm</i>	<i>ERP in dBm</i>	<i>Link Margin in dB</i>
1.5	2.4	14.0	0.0	108	17	31	28.0
2.0	3.2	14.0	0.0	110	17	31	25.5
5.0	8.0	14.0	0.0	118	17	31	17.6
8.0	12.9	14.0	0.0	122	17	31	13.5
10.0	16.1	14.0	0.0	124	17	31	11.5
12.0	19.3	14.0	0.0	126	17	31	10.0
14.0	22.5	14.0	0.0	127	17	31	8.6
20.0	32.2	24.0	1.4	130	17	41	24.1
35.0	56.3	24.0	1.4	135	17	41	19.3
50.0	80.5	24.0	1.4	138	17	41	16.2

Table 2: Fade Margin Chart

You can also calculate your own path loss using the integrated radio link margin calculator included on the CWT product CD in a folder called “Calculators”.

Video Transmitters

These devices use analog radios which are usually fixed in frequency, utilize 6 to 10 MHz of bandwidth and are low power with an ERP of less then +10dBm.

2.1.6 RF Cable Sizing and Recommendations

Before making any decisions as to which cable to use, first consider several factors; the final length of the cable, the amount of power you want the cable to tolerate, the loss factor of the cable at your chosen frequency and the outdoor climate conditions the cable will be exposed to. For most general installations, LMR400 will work fine. Helix™

is recommended for any cable runs over 100 feet. The chart below provides the loss factor for several popular cable sizes.

Coax Cable Attenuation (dB per 100 feet)		
Cable Type	at 2.5 GHz	at 5.8 GHz
LMR 400	6.8 dB	10.8 dB
LMR 500	5.5 dB	8.9 dB
LMR 600	4.4 dB	7.3 dB
1/2 inch LDF Helix™	3.9 dB	7.0 dB
LMR 900	3.0 dB	4.9 dB
7/8 inch LDF Helix™	2.3 dB	3.7 dB

Table 3: Coax Cable Loss Table

2.1.7 Data Cable Recommendations

The new design of the Trailblazer replaces proprietary cables with standard CAT5 Ethernet cables terminated with RJ45 connectors for the sync and repeater functions. **NOTE:** Feed the cable through the weatherproof cord grip **before** terminating it. The cord grip is too small to accept an RJ45 connector especially while occupied by other cables!

2.1.8 General Tools

- ESD Gear
- Desktop PC or Laptop Computer with Windows™
- Wrench Set
- Socket Set
- Screwdriver Set
- Multi Meter
- Butt-set or Test Telephone with bare wire connection
- Wire Cutters
- Wire Strippers
- Vapor Wrap
- Electrical Tape
- Small Non-Conductive adjustment tool
- Safety Gear

2.2 Unpacking

NOTE: Always observe ESD precautions when handling circuit boards!

Before opening inspect the shipping box(es) and report any damage to the shipping carrier. Unpack and compare the contents against the packing slip and inspect for damage. Report any damage to the units or missing components to your CWT sales representative.

Included in your purchase is:

- The Quick Start Guide to help you become familiar with your system
- The CWT Product CD (contains the user manuals, back up configuration software, and other needed items!)
- (2) Test Antennas for bench testing
- One Serial Interface Cable to connect to the GUI
- Mounting Hardware (optional)
- Power Supplies (optional) will be pre-installed in the enclosures

2.3 Bench Testing Instructions

Before going into the field set up the units on your bench to become familiar with their set up, operation, configuration, and verify their functionality. Each system is shipped with a handy, full-color “Quick Start Guide” for simplified step-by-step instructions for bench testing. The following section will provide you with the same information in greater detail.

2.3.1 Setting up Your Trailblazer on the Bench

Set your units next to each other and attach the included test antennas to the N female connectors on the enclosures as shown. The units may not achieve an RF connection without these little antennas.

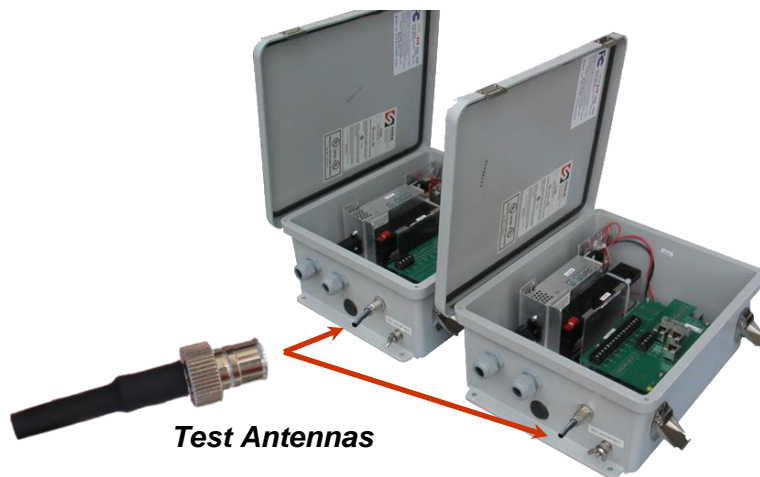

2.3.2 Powering the Trailblazer

The Trailblazer units accept 12 -24VDC **negative ground**. There are special provisions for using a positive ground, please contact your CWT sales representative for more information. If your system is equipped with a battery backup, verify that the battery output is 12VDC or more. If the battery output is less than 12VDC, disconnect the power supply's black and red power cables, connected to the terminal block, from your unit, and simply connect the power supply's terminated red (+) and black (-) power cables to their respective terminals on the battery. Plug the AC power supply cable into an AC source to charge the battery, and verify that the battery is charging. Ensure that the battery is fully charged before proceeding into the field. When the battery is fully charged, verify that the unit powers up by noting that the LEDs are lit.

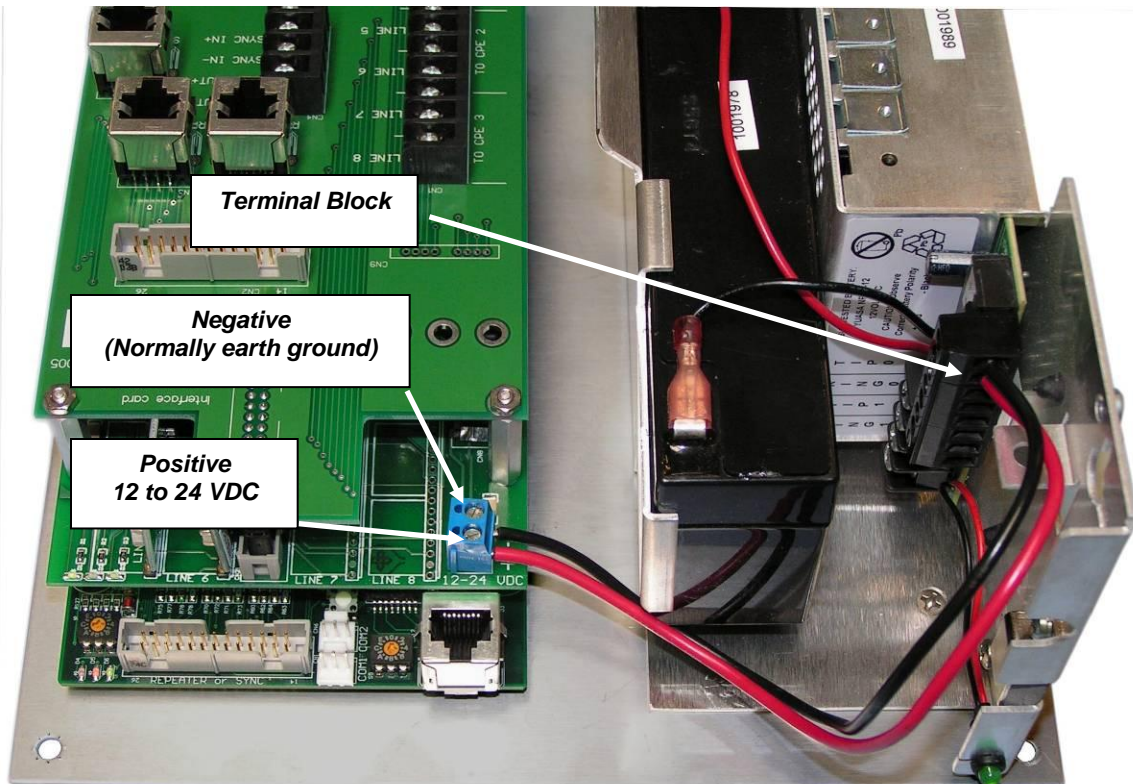

Figure 2: Base Unit Power Connections

If you are not using the CWT power supply, size your power supply adequately using Ohm's law. For example, if you provide 12VDC you consume 2/12 A or about 167mA. If you provide 24VDC you use about half of that or 85mA. CWT recommends providing at least 4 times the power consumption. The Trailblazer consumes 2 Watts. CWT's power supply with battery backup supplies 13.8VDC @ 1 A or 14 Watts.

You can also power your Trailblazer by using several of the unused voice/data pairs in a standard 6 pair telephone cable. Don't forget to allow for additional current if add-on card options are selected.

The standard 6 pair telephone cable is made of 22 AWG size copper. This means that both legs will have 3.2 ohms of resistance per 100 feet. The table below shows the distance at which you have a 5% maximum recommended voltage drop using 2 pairs of wires paralleled together.

Cable Size (A.W.G.) (mm)	Ohms/100ft (both legs)	feet per Ohm (both legs)	if feeding 13.8, distance with 5% (voltage loss 2pr.)	if feeding 24, distance with 5% (voltage loss 2pr.)
14	1.63	194	1783	6202
16	1.29	122	1125	3912
18	1.09	77	707	2458
19	0.91	61	560	1949
22	0.64	30	279	970
24	0.51	19	176	611
26	0.41	12	111	385

Table 4: Feed Cable Sizing and Distance for the Trailblazer

2.3.3 Connecting the POTS Lines

Connect POTS lines as shown in the figure below using the black screw terminals on the units' interface cards. Remember to connect the telephone line(s) from the phone company to the Base unit and the handset(s) to the CPE unit. The location of your active lines will depend on the time slots selection made by the CPE and the bandwidth used. Note the "Active Line" label on your Base and CPE units.

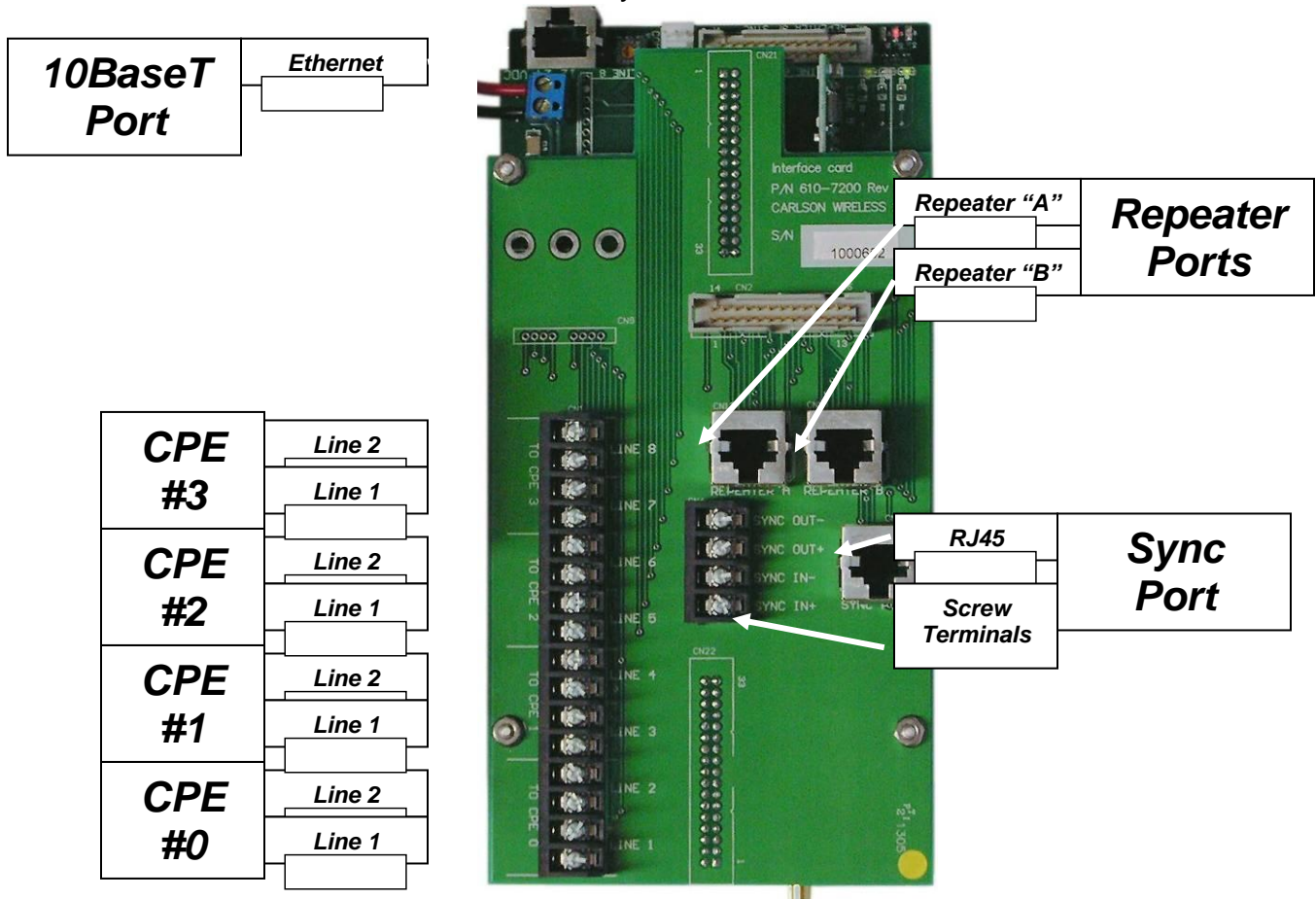

Connecting POTS lines, Repeater, and Sync

For durability as well as ease of installation and acquisition, repeater and synchronization cables require standard RJ45 connectors and CAT5 cable using standard Ethernet cable wiring. Remember to feed the CAT5 cable through the weatherproof cord grips before terminating the ends. In addition to the RJ45 connector, there are (4) screw terminals for synchronization. Wire SYNC OUT to SYNC IN and vice versa.

2.3.4 Connecting the Leased Lines

The Leased Line interface is provided on two standard 50 pin female Centronics connectors. The connector 1 contains the audio and E&M signaling for lines 1 through 4, and connector 2 contains the audio and E&M signaling for lines 5 through 8. See figure below for pin out information:

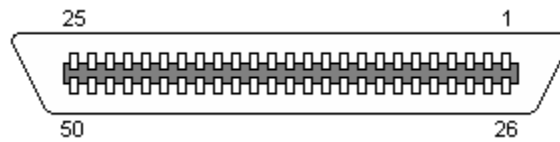

50 Pin Centronics Connector

Connector pin-out:

Connector 1		Connector 2	
Pin	Signal	Pin	Signal
1	Transmit Audio 1+	1	Transmit Audio 5+
26	Transmit Audio 1-	26	Transmit Audio 5-
2	Ground	2	Ground
27	Transmit Audio 2+	27	Transmit Audio 6+
3	Transmit Audio 2-	3	Transmit Audio 6-
28	Ground	28	Ground
4	Transmit Audio 3+	4	Transmit Audio 7+
29	Transmit Audio 3-	29	Transmit Audio 7-
5	Ground	5	Ground
30	Transmit Audio 4+	30	Transmit Audio 8+
6	Transmit Audio 4-	6	Transmit Audio 8-
31	Ground	31	Ground
7	Receive Audio 1+	7	Receive Audio 5+
32	Receive Audio 1-	32	Receive Audio 5-
8	Ground	8	Ground
33	Receive Audio 2+	33	Receive Audio 6+
9	Receive Audio 2-	9	Receive Audio 6-
34	Ground	34	Ground
10	Receive Audio 3+	10	Receive Audio 7+
35	Receive Audio 3-	35	Receive Audio 7-
11	Ground	11	Ground
36	Receive Audio 4+	36	Receive Audio 8+
12	Receive Audio 4-	12	Receive Audio 8-
37	Ground	37	Ground

13	E1	13	E5
38	M1	38	M5
14	E2	14	E6
39	M2	39	M6
15	E3	15	E7
40	M3	40	M7
16	E4	16	E8
41	M4	41	M8
17	Ground	17	Ground
42	Ground	42	Ground

If a standard telephone cable is used, the connections may be brought to pre-wired punch blocks using two 25 pair telephone cables. The location of the signals is shown in the following table as they appear on a standard punch block. The punch block terminals are numbered from top to bottom. The 50 pin Centronics connector pins (abbreviated Ctrnx) are included for reference.

50 pin Ctrnx	Punch Term	Signal name	50 pin Ctrnx	Punch Term	Signal name
26	1	Transmit Audio 1-	26	1	Transmit Audio 5-
1	2	Transmit Audio 1+	1	2	Transmit Audio 5+
27	3	Transmit Audio 2+	27	3	Transmit Audio 6+
2	4	Ground	2	4	Ground
28	5	Ground	28	5	Ground
3	6	Transmit Audio 2-	3	6	Transmit Audio 6-
29	7	Transmit Audio 3-	29	7	Transmit Audio 7-
4	8	Transmit Audio 3+	4	8	Transmit Audio 7+
30	9	Transmit Audio 4+	30	9	Transmit Audio 8+
5	10	Ground	5	10	Ground
31	11	Ground	31	11	Ground
6	12	Transmit Audio 4-	6	12	Transmit Audio 8-
32	13	Receive Audio 1-	32	13	Receive Audio 5-
7	14	Receive Audio 1+	7	14	Receive Audio 5+
33	15	Receive Audio 2+	33	15	Receive Audio 6+
8	16	Ground	8	16	Ground
34	17	Ground	34	17	Ground
9	18	Receive Audio 2-	9	18	Receive Audio 6-
35	19	Receive Audio 3-	35	19	Receive Audio 7-
10	20	Receive Audio 3+	10	20	Receive Audio 7+
36	21	Receive Audio 4+	36	21	Receive Audio 8+
11	22	Ground	11	22	Ground
37	23	Ground	37	23	Ground
12	24	Receive Audio 4-	12	24	Receive Audio 8-
38	25	M1	38	25	M5
13	26	E1	13	26	E5
39	27	M2	39	27	M6
14	28	E2	14	28	E6
40	29	M3	40	29	M7
15	30	E3	15	30	E7
41	31	M4	41	31	M8

16	32	E4	16	32	E8
42	33	Ground	42	33	Ground
17	34	Ground	17	34	Ground

3 Operation

3.1 Configuring and Accessing the Trailblazer Unit

3.1.1 Connecting the Serial Cable

You can access your Trailblazer with the GUI program, included on the CWT product CD, and the included serial cable. Simply plug the DB 9 connector of the serial cable into the serial port on your computer and the three pin connector to the three pin connector (COM1) on the radio board (bottom board) as shown. **DO NOT USE COM2!** It is currently reserved for future applications.

NOTE: Unpredictable results may occur if you are using a USB to serial COM Port adapter!

Should you need to replace the serial cable, contact CWT or see *Section 6.3.1* in the appendix for a pin-out and a description on how to make one.

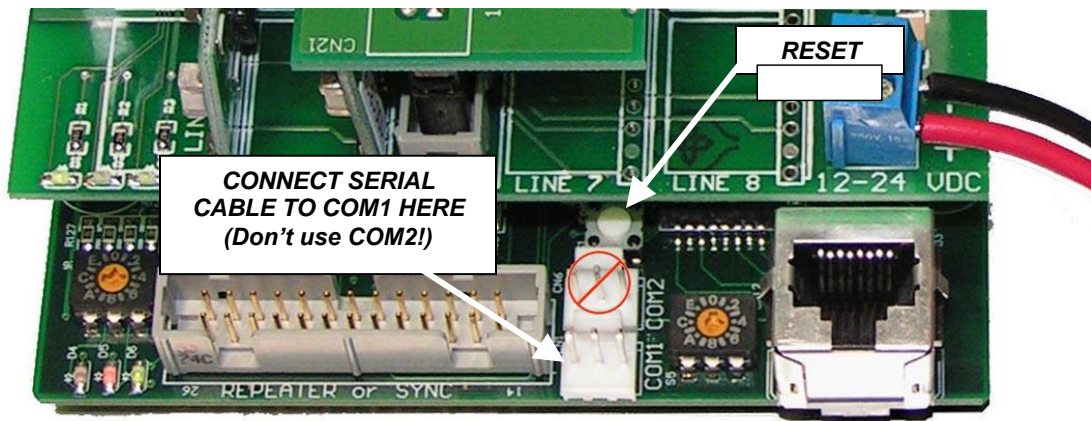

Figure 3: Connecting the Serial Cable

3.1.2 Installing the CWT GUI on Your PC

The CD included with your system contains a folder called “GUI” with the self executing file **CWT Trailblazer GUI 1.0x.xxxx [ALL-OS].exe**. Browse to the CD and open the file to install the GUI program on your PC. After you have successfully installed the GUI, start the program by either double clicking the **CWT Trailblazer GUI ver. x.xx** file on your desktop or browse start-> programs-> Carlson Wireless Technologies Inc-> **CWT Trailblazer GUI ver. x.xx**

3.1.3 Using the GUI

Double click the CWT icon and choose the appropriate COM port connected to your serial cable.

After you have selected the correct COM port, the software will display the connected unit's current configuration data.

The screen will look slightly different depending on whether you are connected to the CPE or Base unit. The box highlighted in green will display the type of unit that is currently communicating with the software. **All systems are shipped pre-configured. Do not change any parameters unless advised to do so by a CWT technician.** The integrated V.35 data port can be enabled and disabled here as well.

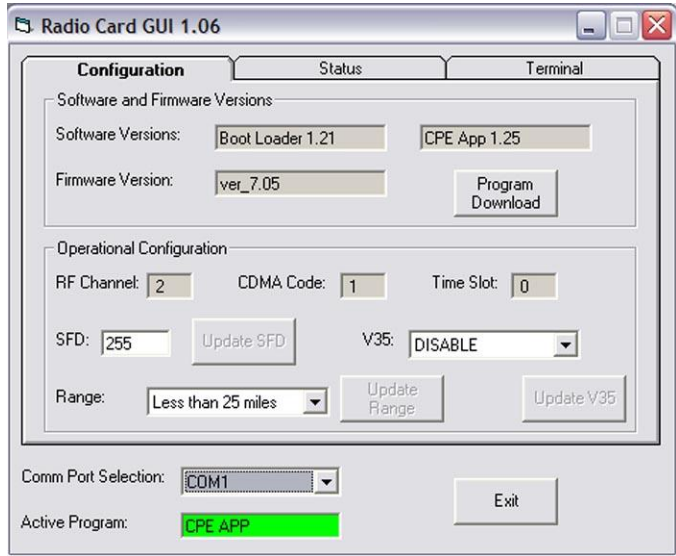

3.1.4 Software Downloads Using the GUI

To download new software, click on the “Program Download” button on the *Configuration* tab and browse to the location of the file as shown to the right. For the CPE units, use the firmware “*station_xxx*” file and the software ***CPE APPxxx.hex*** file. For the Base unit, use the firmware “*station_xxx*” file and the software ***LINE CARD APPxxx.hex*** file. Select the file, and click “Open” to start downloading.

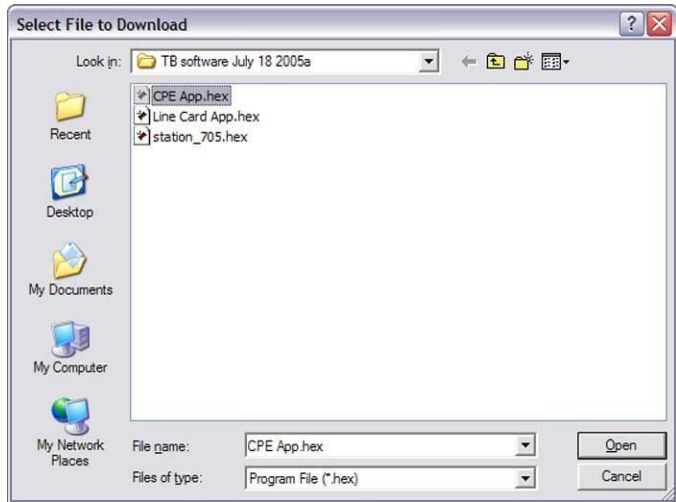

GUI Showing File Browser

The new CPE and Base unit software will take about a minute to download. The firmware takes about 3 or 4 minutes to download. To the right you will see a sample view of what you should see during the download.

Do not interrupt the download! When the download is complete, the unit will automatically reboot and update the version numbers. Once the “Program Download” button reappears, you can select another file to download.

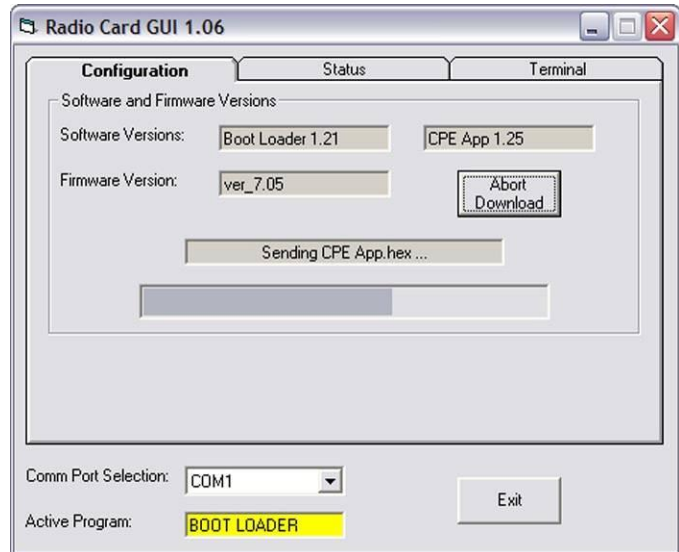

Loading Software with the GUI

Select the *Status* tab to view the current status of RF link, signal strength, line “hook” state, SFD loss count and an on-board temperature reading. Select DISCONNECT in the COM Port selection box before moving the serial cable to another radio card. Resume connection and status readings by selecting the active COM port. The battery voltage status only applies to CPEs equipped with solar power.

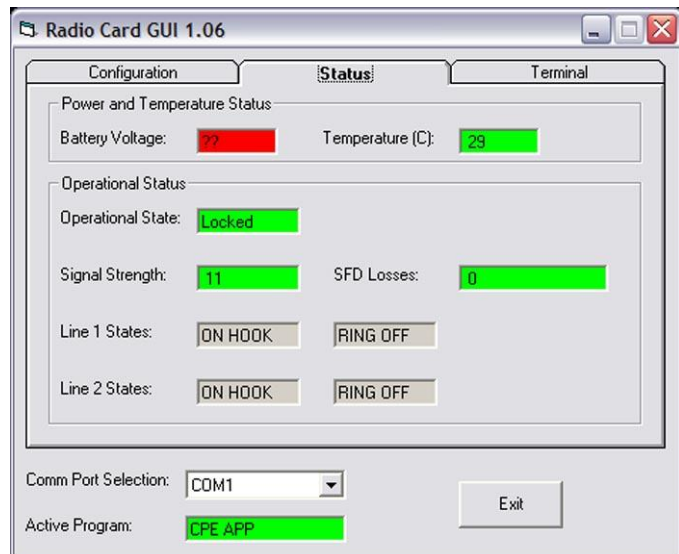

GUI Showing Status of a CPE

Click on the Terminal tab to monitor status, view and log real-time link quality reports and manually interface with the Trailblazer radio cards via the Terminal screen. In the middle of the terminal screen you will notice a command line box. One command at a time may be entered and sent to the radio card via this terminal interface or by using terminal software.

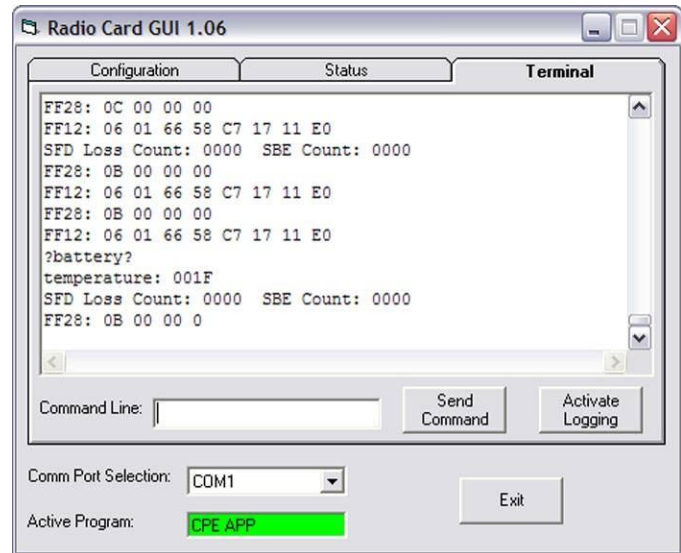

GUI showing status of a CPE terminal

3.2 Accessing the Trailblazer using HyperTerminal™

3.2.1 Windows™ HyperTerminal™ Software

As a secondary precaution, as well as to allow user access to advanced configurations, such as allocation of bandwidth to data and voice lines not supported by the GUI software, the Trailblazer system is alternately equipped with a terminal interface. If you do not have access to a PC with the Windows™ operating system or have trouble with the GUI software, many diagnostic and setup tasks can be performed with a basic terminal program such as Windows HyperTerminal™. See Section 6.4 in the Appendix for connection instructions, settings and usage.

3.3 Setting the Radio Frequency and Scrambling Code

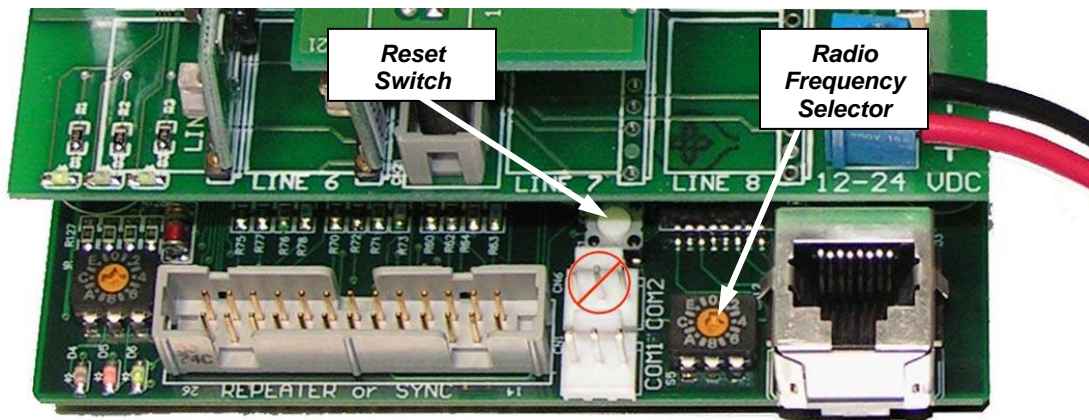

Figure 4: Rotary Switch and Reset Button

The radio frequency and scrambling code of the Carlson Wireless radios operate on numerous band selections based on **purchased** configuration. Within the selected operational band, multiple frequencies are provided in combination with code variations. Selections within the offered band are provided using the 16 position rotary switch located between the 10BaseT port and the white three pin connectors. The tables below show the switch settings for the 16 frequency/code combinations for each band currently offered.

Channel ↴	5.875 GHz	5.905 GHz
code 0	0	1
code 1	2	3
code 2	4	5
code 3	6	7

Table 5: 5.8-9 – Frequency/Code Switch Matrix

3.3.1 Selecting the CPE Time Slot

Up to (4) CPE units can communicate with each Base unit when used in a STAR topology. To distinguish between the four CPEs, a different time slot is allocated to each CPE using the rotary DIP switch located immediately behind the LEDs as shown in the figure below. Use a **non-conductive** trim tool to select time slots 0, 1, 2, and 3 to avoid shorting any components. Reset the unit to put your selection in effect by pressing the reset button located behind the second white three pin connector as shown.

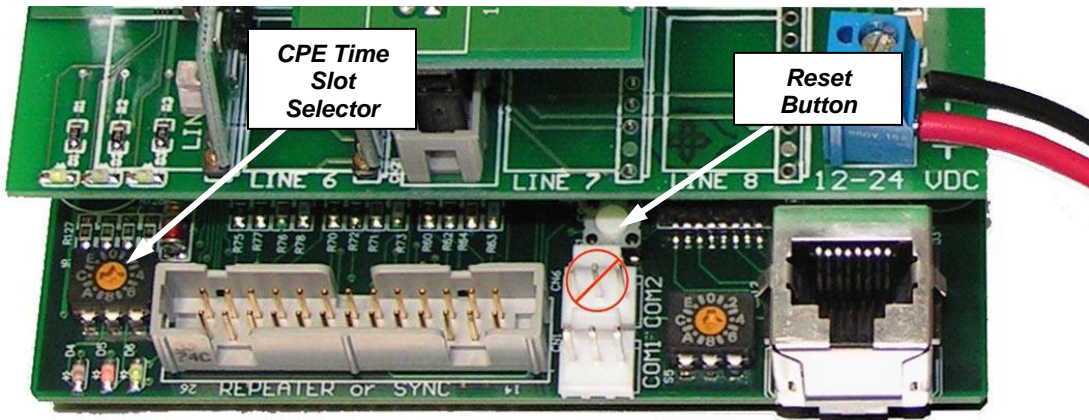
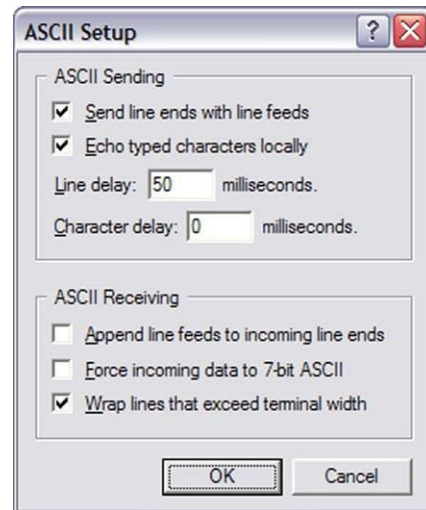

Figure 5: CPE Time Slot Selection Switch

3.4 Allocating Bandwidth to Voice and/or Data

Preceding future integration of these functions into GUI software, some system configurations must be performed on a manual text entry level. To do this, you can interface with the Trailblazer radio card using either the GUI software on the Terminal screen (See Section 3.1.3) or by using the HyperTerminal™ software. You will also need to add a 50ms delay to the linefeed in your terminal ASCII settings in order to send text commands to Trailblazer radio through terminal software. See screenshot (right) for an example.



the
be
you

add

the
the

Begin by starting the GUI or making sure your terminal software is loaded and properly configured to communicate with the Trailblazer radios. See Section 6.4 for configuration instructions.

Each setting is controlled by a short “*command name*” followed by an EEPROM register or “*switch*” designated by a letter or letters on your screen. Type the command name for the function you wish to implement followed by the appropriate “*switch*” and press enter. The Trailblazer radio card should respond by echoing the new setting back to you. It usually takes (7) sets of these commands to configure a radio card for any of its many functional states. The settings may be changed one at a time or combined in a text file, known as a “script”, and loaded into the Trailblazer radio card. See the following table for details and examples.

	Write to EEPROM register	EEPROM register	0=Star 8=P2P	# of Total Ch.
	wee	e		
	Write to EEPROM register	EEPROM register	# of Data Channels	
	wee	f	0	
	Write to EEPROM register	EEPROM register	# of Data Ch.	# of Voice Ch.
<i>CPE 0</i>	wee	10		
<i>CPE 1</i>	wee	11		
<i>CPE 2</i>	wee	12		
<i>CPE 3</i>	wee	13		
	reset			

Table 5: Commands and switches for bandwidth

To set for Star topology or Point-to-Point and Bandwidth of the Base unit:

This is set using the EEprom register “E”.

If the first digit of the switch setting or “most significant digit” is an “8” then it is planned to be in point-to-point mode. If the first is “0” or none then it will be in Star mode.

The second digit or “least significant digit” is for the bandwidth (as transmitted from the base unit) with the number corresponding to how many 64 kb channels are made available.

For example, type in though Hyper terminal or the GUI window [**wee e 84**]

The system should respond back with [**000E: 84**]

This will set up a Point to Point with 256 kb available bandwidth.

Entering [**wee e 08**] would set the radio to be a Star with 512 kb bandwidth.

To allocate total data Bandwidth of the base unit:

To allocate data channels in 64kbps increments, EEprom register “F” is the total number of data channels allocated to the Base unit.

To allocate total data Bandwidth of the CPE terminal:

To allocate channels to the CPE stations, the EEprom registers 10,11,12,13 are used.

This will handle up to (4) CPEs in a star configuration.

In the CPE, EEprom registers 10,11,12,13 the MSB is used to state the amount of 64kb channels bonded for data. The LSB is used to state the number of 64kb channels available for voice services. See the following table for some example scripts.

Point to Point	Point to Point	Star
256kb bandwidth, 2 data channels and 2 voice channels:	256kb bandwidth, 3 data channels and 1 voice channel:	512kb bandwidth, 2 voice channels for each CPE:
wee e 84 000E: 84	wee e 84 000E: 84	wee e 08 000E: 08
wee f 02 000F: 02	wee f 03 000F: 03	wee f 00 000F: 00
wee 10 22 0010: 22	wee 10 31 0010: 31	wee 10 02 0010: 02
wee 11 00 0011: 00	wee 11 00 0011: 00	wee 11 02 0011: 02
wee 12 00 0012: 00	wee 12 00 0012: 00	wee 12 02 0012: 02
wee 13 00 0013: 00	wee 13 00 0013: 00	wee 13 02 0013: 02
reset	reset	reset

Table 6: Example configuration scripts

Additional Configuration Notes:

- Total transmit channel count may only be 1, 2, 3, 4, 5, 6, 7, or 8
- Total CPE channels may not exceed 8
- The sum of CPE voice and data channels may not exceed 8 either individually or collectively
- Currently, all timeslots must be the same return bandwidth
- There are distance issues regarding use timeslot zero (TS0)

4 Field Installation Options

4.1 Mounting the Enclosure

The versatile mounting bracket assembly (PN: 900-7200) allows the Trailblazer enclosure to be properly mounted on a pole up to 2.25" in diameter. The mounting bracket assembly also converts to a wall mount for mounting the Trailblazer enclosure on a flat surface. See below for details for the two different mounting applications.

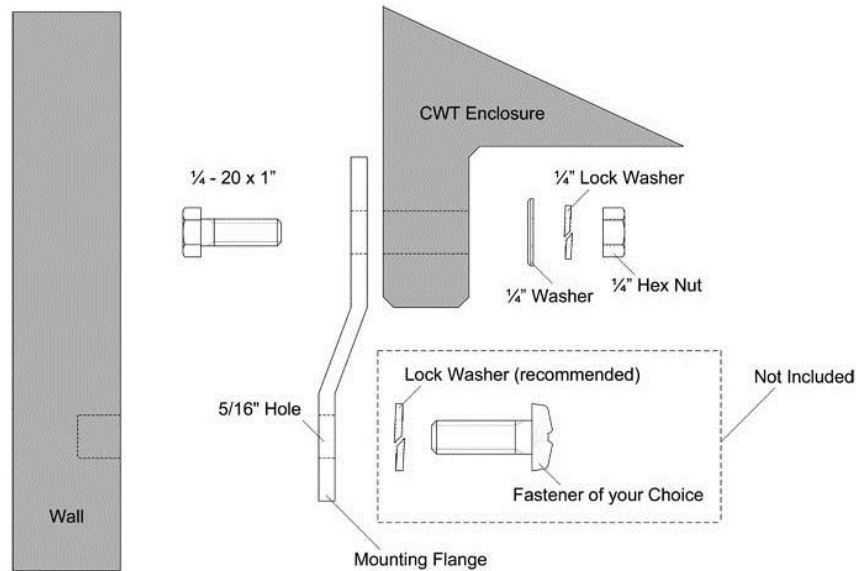

Figure 6: Wall mounting the Trailblazer enclosure

Wall Mounting Instructions:

- Attach the mounting flanges to the enclosure using the 1/4 -20 x 1" bolts, 1/4" flat washers, 1/4" lock washers, and 1/4" hex nuts.
- Tighten the 1/4" nuts to maximum of 25 in-lbs (2.1 ft-lbs). **Do not over tighten!**
- Position the enclosure on the wall.
- It is recommended that you attach the enclosure to the wall using a lock washer and fasteners of your choice as shown in figure 2.
- Tighten the fasteners of your choice. **Do not over tighten!**

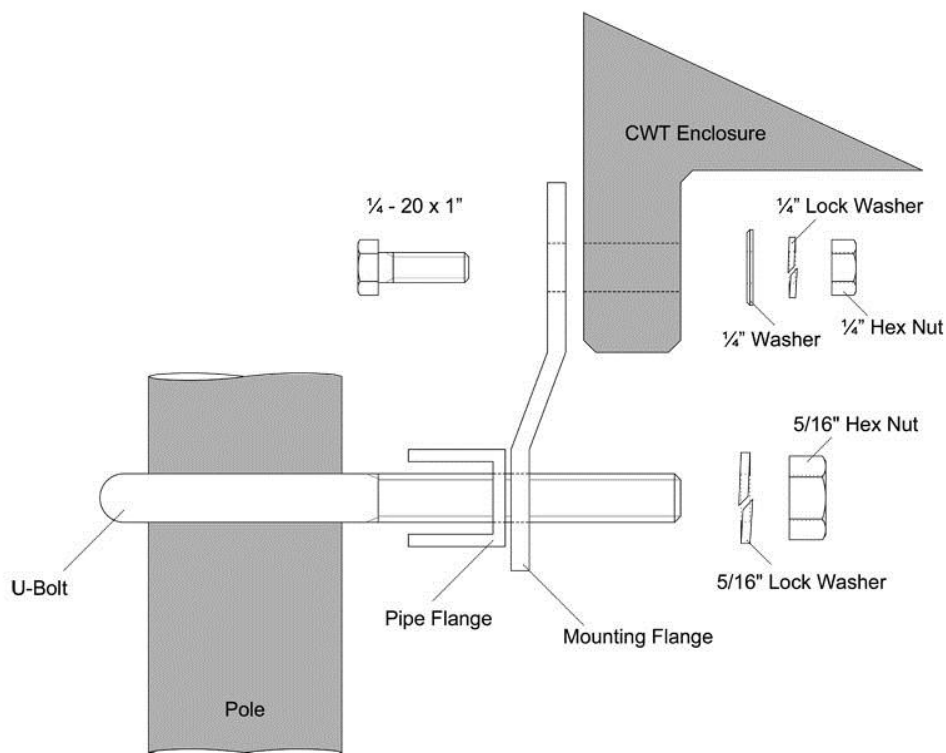

Figure 7: Pole mounting the Trailblazer enclosure

Pole Mounting Instructions:

- Attach the mounting flanges to the enclosure using the 1/4 -20 x 1" bolts, 1/4" flat washers, 1/4" lock washers, and 1/4" hex nuts.
- Tighten the 1/4" nuts to maximum of 25 in-lbs (2.1 ft-lbs). **Do not over tighten!**
- Position the enclosure on the pole.
- Place the U-bolts around the pole, and slide the pipe flanges over them with the serrated sides facing the pole. See figure 1.
- Apply an anti-seizing compound to the threads of the U-bolts.
- Slide the mounting flanges (now attached to the enclosure) over the U-bolts and secure them using the 5/16" lock washers and 5/16" hex nuts.
- Tighten the 5/16"nuts. **Do not over tighten!**

4.2 External Antennas

The use of an external antenna with Model Trailblazer RC Pro system mandates professionally trained personnel to ensure compliance with FCC rules and regulations. Specifically the installer must ensure that the EIRP of the transmitting antenna does not exceed the requirements of the Code of Federal Regulations, Title 47, Part 90 subpart m.

This device has been designed to operate with the antenna listed below, and having a maximum gain of 16 dB. Antennas not included in this list or having a gain greater than 16 dB are strictly prohibited for use with this device. The required antenna impedance is 50 ohms.

WARNING! YOU CAN BE KILLED!

The Trailblazer system is designed to be installed by professionally trained installers only! Failure to follow basic installation procedures and safety precautions can result in one or all of: damage to tools and/or equipment, interference with and/or damage to other equipment or accessories, violation of safety code, local laws and/or building codes, personal injury or even death.

Detached antennas, whether installed indoors or out, should be installed ONLY by experienced antenna installation professionals who are familiar with local building and safety codes and, wherever applicable, are licensed by the appropriate government regulatory authorities. Failure to do so may void the CWT product warranty and may expose the end user to legal and financial liabilities."

"Regulations regarding maximum antenna gains vary from country to country. It is the responsibility of the end user to operate within the limits of these regulations and to ensure that the professional installer is aware of these regulations, as well. "

Installations of the Trailblazer System require topographic analysis, site survey, and link budget calculation; therefore CWT trained professionals are required to perform the installation.

4.2.1 Marketing and Sales Channels

CWT DOES NOT sell the Trailblazer PRO direct to end users. i WLL Trailblazer PRO System will be sold only to CWT's Authorized Resellers. Those authorized resellers are technically trained by CWT's Engineers periodically and must follow the rules set by CWT. The Trailblazer PRO system is designed for Long Range (15-35 miles) applications and it involves a complicated mandatory site survey, roof top mast installation, high gain antennas, accurate antenna alignment, etc. Those activities can be done ONLY by professional installers that are familiar with the FCC regulations. CWT does not sell the Trailblazer PRO in the consumer business at all. We have no resellers in this market and we do not advertise in consumers based publications or attend consumer oriented trade shows. The system will be advertised in technical trade shows and magazines.

4.2.2 Calculating the EIRP of an External Antenna

For the 5.8 – 5.9GHz bands of frequency, the output of the Trailblazer TB series radio is calibrated at the factory to limit the peak power output to +7dBm.

Using this example one can calculate the following:

Note that the radio is calibrated for a maximum output power of +7dBm.

Subtract the interconnecting cable and lightning protection losses of 2dB = total power arriving to antenna of 15dBm. .

For 5.8 – 5.9GHz, the FCC allows a maximum EIRP of 23dBm. This would mean that an antenna with a gain of 16dBi would be acceptable with no cable losses.

Following this guideline ensures compliance with the maximum transmitter ERP allowed with the antenna provided as a system.

4.2.3 RF Safety Hazard Warning

Due to the substantial energy radiated from these antennas, it is imperative that they never be mounted such that the antenna or the cabinet containing the antenna will be closer than 2 Meters (6.7 Feet) to any persons.

4.3 16dBi 5.8 - 5.9 GHz Sector Base-Station Antenna

This section is designed to support the installation, operation and maintenance of the 16dBi directional sector antenna. Due to its small size, ease of mounting and low maintenance it is most commonly used in conjunction with the Trailblazer system. To avoid harm to persons or damage to the product please ensure that you have read through the safety, unpacking and installation sections before proceeding.

4.3.1 Product Overview

The 16dBi directional sector antenna includes adjustable Heavy Duty brackets to provide down or up tilt mounting to a mast up to 3 inch O.D. These outdoor antenna systems are designed to provide maximum gain in the 5.8-5.9GHz band as well as survive high wind environments.

Refer to the “Product Specification” Section for specifications and characteristics.

Key Features and Benefits:

- Patented printed circuit board design. Best performance-to-price ratio.
- Attractive, low profile UV stable housing. Blends well with indoor and outdoor environments where aesthetic considerations are important.
- Corner exit RG-58/U pigtail design. Permits the panel to be mounted in vertical or horizontal polarity.
- Adjustable mounting brackets for outdoor mounting. Provide maximum flexibility for outdoor installations.

4.3.2 Unpacking

The 18dBi directional flat panel is smaller in size and therefore may be packaged with other items. Thoroughly inspect the package and the antenna inside before proceeding. Immediately report any damage to the shipper.

4.3.3 Mounting

Included with the antenna you will find the L brackets for both antenna and poll mounting. These L brackets allow for up and down tilt adjustments. Poll brackets allow for 1.5 – 3 in poll mounting. You will need two 12mm wrenches along with cable ties to properly secure connections and feed cables.



Antenna Airmax Sector 5G-120-16

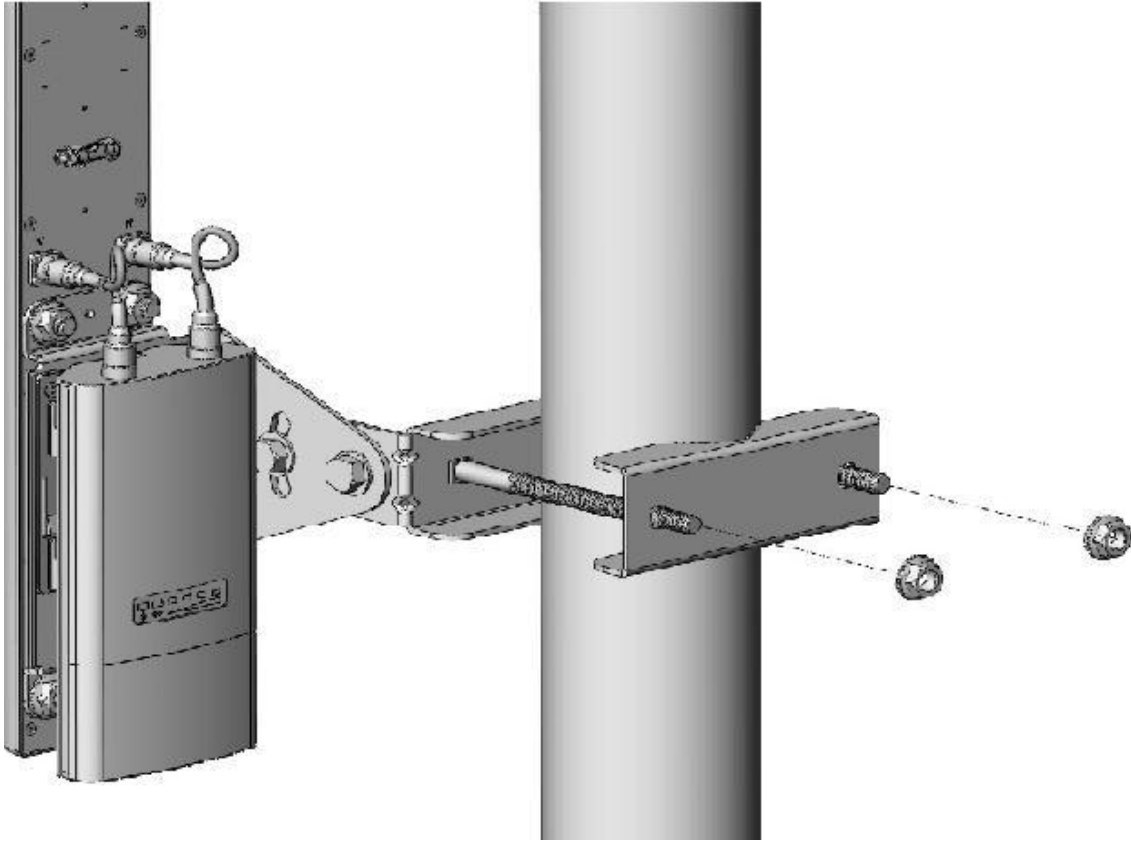

This is a properly mounted sector antenna. Note the ability of the mount to aim the antenna uptilt, downtilt and to either side.

4.4 Weatherproofing RF Connections

Once you have the antenna mounted and secured. Complete the installation by properly attaching the weatherproof cables.

4.5 Antenna Alignment

Rough alignment: This is fairly straight forward. Since it is a prerequisite that you have line of sight between the two points, here are several ideas that have worked for installers:

- If you can see the other unit, simply aim the units towards each other.
- During midday, use a mirror or compact disk to create a reflection approximately towards the other site while someone watches for the flash.
- Plot out the path on a topographical map and set the antennas using a compass.

How close in alignment do they need to be? +/- 6 degrees will be adequate for most paths using the 16 dB gain antenna. Certain paths that have a low fade margin may require a more accurate setting.

Alignment indicators: Due to the nature of digital modulation and the associated circuitry, there is no analog test point at which the signal strength may be monitored. Rather, the bit error rate is indicated on the digital board. If there are obstructions or interference in the link the middle, red LED will begin to blink. The rate of flash is an indication of the degree of signal degradation, with a higher flash rate indicating more errors.

Final alignment is performed by connecting a standard telephone directly to the CPE terminal (FXS) and listening to the dial tone. As the antenna is moved to the left the signal will degrade, the bit error LED will flash, and eventually the link will be lost. Note where the antenna is aimed when the link is lost and rotate the antenna to the other side until the signal is lost again. The midpoint between the positions where the signal was lost indicates the best antenna position. Use the GUI software and a laptop to determine the exact signal peak and then tighten the antenna mounts.

4.6 Interference Solutions

Sometimes after installation, final alignment is found to interfere with external devices, and/or external devices are later installed that affect the Carlson Wireless Radio device. To determine if the Carlson Wireless radio is an interferer, power down the radio unit and check if the interference is removed. To determine if an external device is interfering with the Carlson Wireless radio, shut down suspected devices while listening to an audible tone (such as dial tone) on a phone connected through the Carlson Wireless system.

Common Interferers are: microwave, wireless household controls, emergency radio equipment, cordless telephones, wireless video products, etc. (refer to Interference Section **Error! Reference source not found.** for more information)

Before calling the manufacturer the installer is encouraged to try correcting the problem by trying one or more of the following suggestions:

- Slightly reorient or move the Carlson Wireless antenna to a new position
- Change the frequency of Carlson Wireless radio or offending device
- Relocate the offending/offended device
- Separate power sources, or filter sources between the offenders
- If not installer, consult dealer or experienced technician

4.7 Lightning Protection

CWT stocks in-line, gas-discharge style lightning surge suppressors as primary lightning protection for their reliability, ease of installation and low cost to the customer. In-line protectors mount in series with the coaxial cable or telephone line which provides an excellent solution for a retrofit application. The protector is grounded through an external ground screw that is attached to the body of the surge protector. Be sure to take the other end of this ground circuit into consideration as well.

4.7.1 Antenna Port Protection

Mount the CWT in-line, gas discharge lightning surge suppressor in parallel with the coaxial cable between the radio and the antenna. Place the protector as near the radio as possible in order to limit the amount of cable that will be exposed to either direct or indirect strikes of lightning or atmospheric static charges. Connect the largest wire (usually #8 or #10AWG solid) to the ground screw on the body of the surge protector and terminate it to a proper ground (see above). If you have any question about the quality of your ground system, stop and remedy the issue before continuing.

<i>RF Gas Discharge Lightning Surge Protector Specifications</i>	
CWT Part number	640-6600
Description	High Frequency co-axial surge protector (Gas tube)
Maximum power (50 Ohms)	70 W
Breakdown Voltage (100 V/s)	90-130 V
Residual Voltage (1 kV/μs)	< 600 V
Power Handling (8/20 μs waveform)	10 kA

10 shocks 1 shock	20 kA
Return Loss and Attenuation @ 0.5 GHz @ 1 GHz @ 4 GHz	< -25 dB < - 25 dB < -20 dB
Insertion Loss @ 0.5 GHz @ 1 GHz @ 2.5 GHz @ 4 GHz	< 0.05 dB < 0.03 dB < 0.067 dB < 0.29 dB
Connector Type	"N"
Housing Material	Copper alloy with CuZnSn finish
Contact Sockets Material	Gold Plated Copper alloy
Insulation Material	Teflon per ASTM-D-170

Table 7: RF Lightning Protection

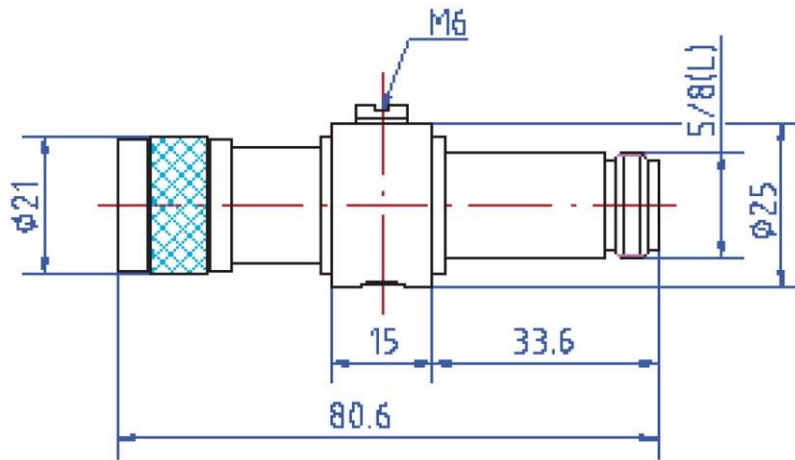

Figure 8: Surge Protection, RF

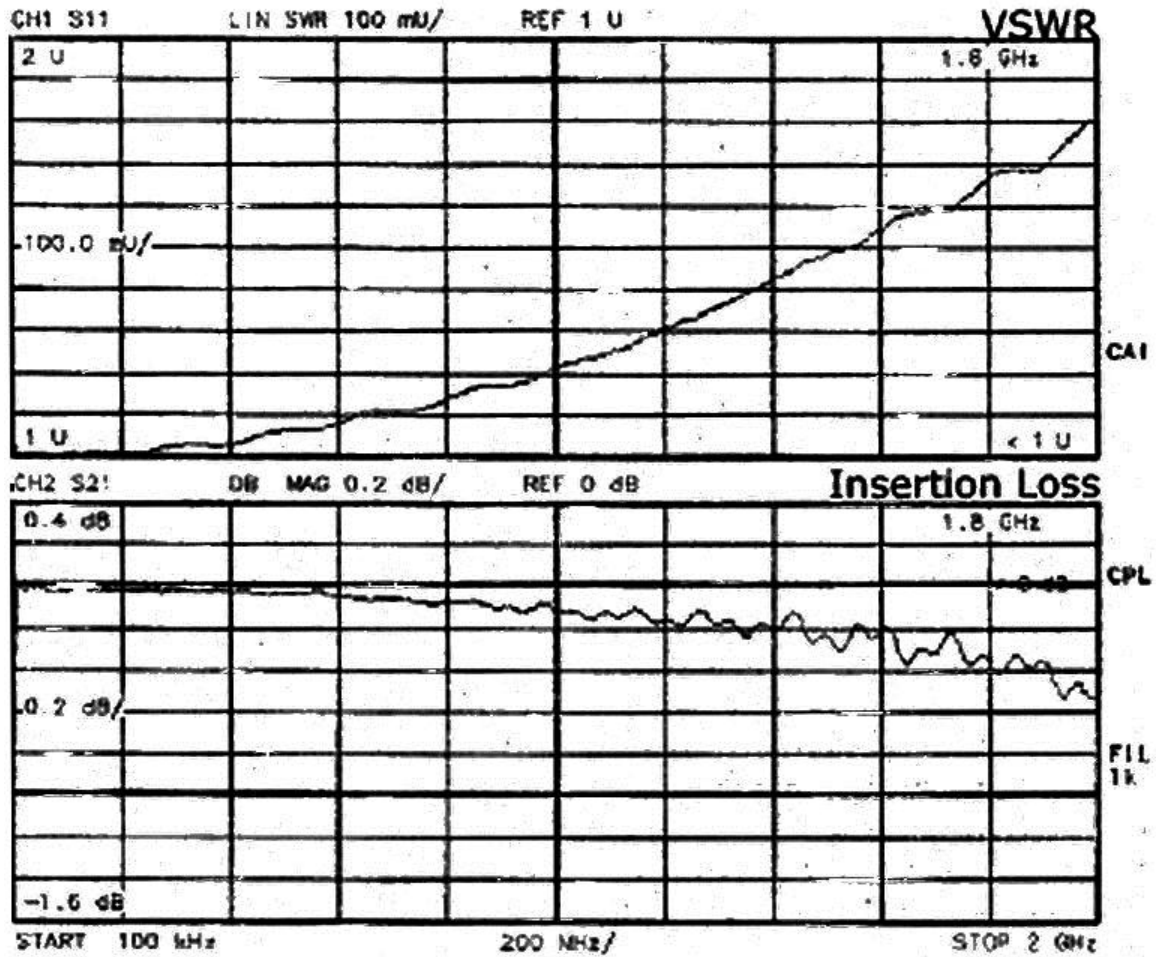

Figure 9: Antenna Port Lightning Protector, VSWR and Insertion Loss

4.7.2 Telephone Line Port/ Subscriber Premises Protection

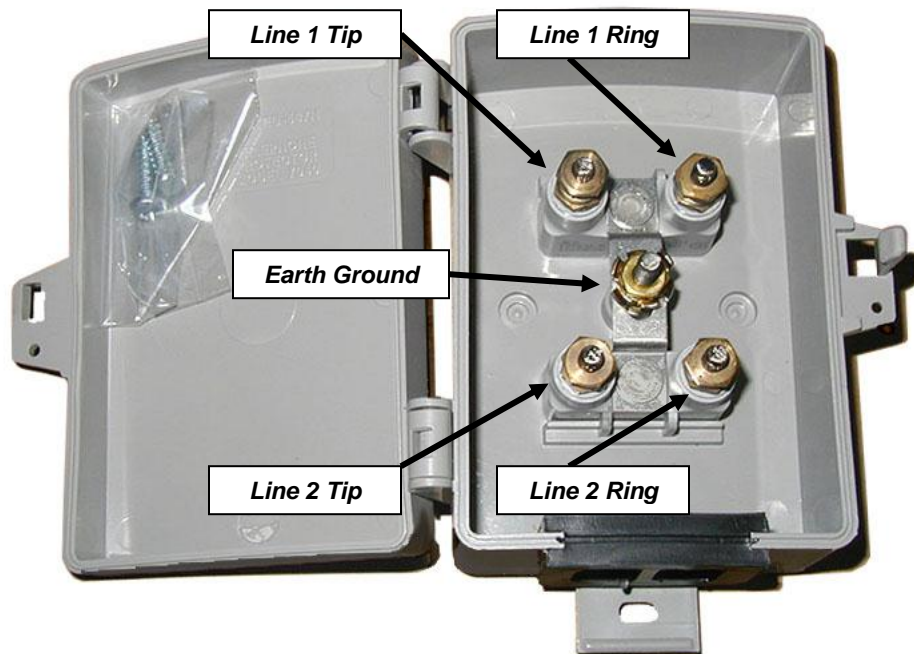

Figure 10: Primary Telephone Line Transient Protection

The telephone line surge protector is designed to be used as a primary station protector at the subscriber end of the loop. It provides protection against lightning surges, power cross conditions, and ground potential rises.

The protector element for each line consists of a heavy duty rated, (2) element gas tube, an external backup gap assembly and a unique switch grade shorting mechanism. The enclosure accommodates two protectors.

Two gas tubes are sealed in a fire resistant plastic body with plated #10 brass studs, washers and hex nuts for connection to (2) subscriber pairs. A plated brass ground connector is slotted to fit the ground connection points of station protector housings and network interface devices. It has sectionalized grommet in base for wire entry.

Telephone Line Gas Discharge Lightning Surge Protector Specifications	
CWT Part number	640-6500
Description	Sealed gas tube station protector
DC Breakdown@100V/s	300-500V
Impulse Breakdown 100V/ μ s 10kV/ μ s 100V/ μ s, vented	600V 850V 1200V
Insulation Resistance@100V/leakage current	10e10 Ω
Capacitance@1kHz	<15pF
DC Extinguishing (Network applied) @52V, 135V, 150V	<150ms
Impulse Life Characteristics	>400x500A 10/1000 μ s 10kA 8/20 μ s
AC Life characteristics	>65A, 11 cycles
Enclosure Material	Weather and UV resistant , high impact, flame retardant plastic.
Dimensions	5.7"H x 3.4"W x 2.2"D

Table 8: Subscriber side protection

5 Test & Maintenance

5.1 Diagnostics

5.1.1 LED Function

The Trailblazer units' are equipped with multifunction status indication LEDs on the top and radio card. There are no LEDs on the interface card. You can read the link and alignment status as well as packet loss information quickly, without using a PC. Use the table below for translating the LED patterns.

	CPE Unit			BASE Unit			Description
	D4	D5	D6	D4	D5	D6	
NO POWER	Off	Off	Off	Off	Off	Off	Power system failure or no power applied
POWER ON	Off	Off	Solid	Off	Off	Solid	Initial Power up, FPGA not loaded by CPU
CPE ACQUIRING	Solid	Solid	Flashing	Off	Solid	Flashing	CPE – receiver on, looking for valid signal. Base - FPGA loaded, radio transmitting
CPE RANGING	Solid	Off	Flashing	Off	Solid	Flashing	CPE acquired and locked, CPE begins transmitting locator beacon
BASE RANGING	Solid	Off	Flashing	Solid	Off	Flashing	Base accepts CPE locator beacon and begins ranging operation
ALIGNMENT	Off	Blinks	Solid	Off	Blinks	Solid	Final alignment, minimizing bit errors
LOCKED	Off	Off	Flashing	Off	Off	Flashing	Units locked and aligned, ready for service
PACKET ERRORS	Off	Blinks	Flashing	Off	Blinks	Flashing	D5 blinking indicates packet errors, weak signal or interference

Table 9: System Status LED Information Table

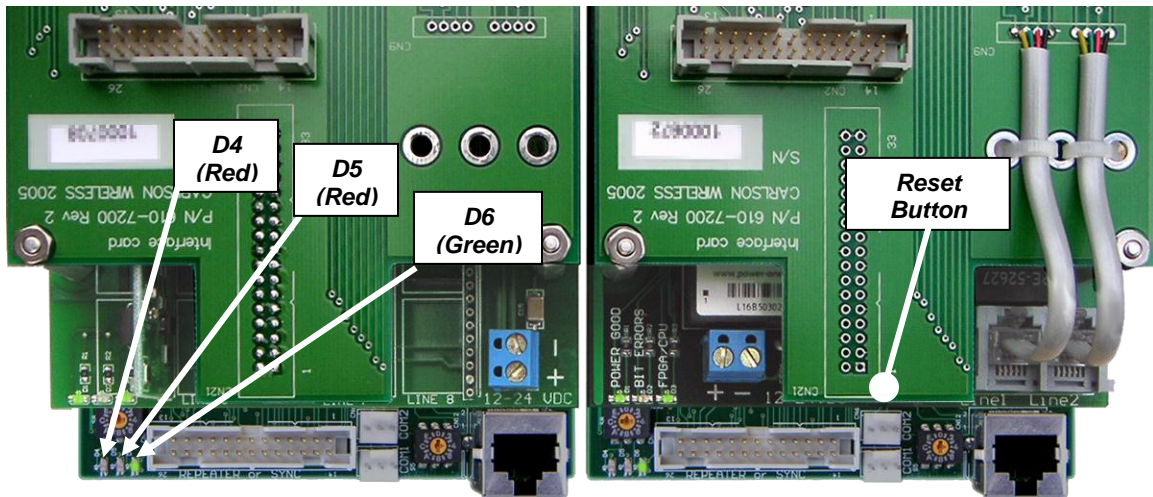

Figure 11: Trailblazer Radio Card LEDs

Setting your units next to each other on your bench with the test antennas attached to the N female connectors on the enclosure. The LED will indicate from top to bottom in the preceding table, from the *No Power* to the *Final Alignment and Errors* state. The Trailblazer system should reach the *CPU Operational* state within 20 seconds after power is applied. The *Acquired* state completes when the CPE terminal has detected and locked to the radio signal from the base unit. The *Ranged* state is complete when the CPE terminal has turned on the radio transmitter and is aligned with the base unit. After ranging both units will do an *Alignment* to minimize bit errors. During the *Operation and Diagnostics* stage, any bit errors are occurring will be indicated by D5 blinking or flashing depending on the severity of the errors. This condition may also be caused by interference or misalignment of the antennas (or weak signal). ***If D4 and D5 are OFF and D6 is FLASHING, the unit is ready for service!***

5.2 Maintenance

5.2.1 Installation of Software/Firmware Upgrades

Most maintenance and upgrading of the system can and should be performed with the included GUI software. See Section 3 for operating instructions for the GUI. If for some reason you are unable to use the GUI software, you may alternately use the Terminal Interface. See the Appendix for advanced programming and diagnostics details.

6 Appendix

6.1 About Carlson Wireless

6.1.1 Mission

Carlson Wireless Technologies Inc. (CWT) is dedicated to designing, manufacturing and marketing innovative, low power digital WLL (wireless local loop) telephone systems that provide high-quality voice and data links for rural and remote telephone users worldwide.

6.1.2 History

CWT (Carlson Wireless Technologies) Inc. was founded in 1999 by James Carlson and is a privately held California "C" corporation headquartered in Arcata, California. CWT purchased the assets of Adicom Wireless Inc. formerly of Pleasanton, CA. Adicom Wireless had spent 4 years and over \$40 million in development of a CDMA multipoint system. The designs and patents are being used this newer Trailblazer RC Point-to-Point and Point-to-Multipoint product line.

6.1.3 Summary

CWT is marketing the Trailblazer product through established telecom and wireless equipment distributors. Please contact our Sales Department +1.707.822.7000, or email sales@carlsonwireless.com for more information.

6.2 System Specifications

Air Interface	*Proprietary DSSS CDMA using a negotiated QOS with Time Division Duplexing
Data Throughput Rate	512, 256, 128, 64 kbps, Configurable with GUI
End-to-End System Latency	Less than 4.4 ms Depending on Speed Selected
Fax Compatibility	G3 (9.6kbps) and G4 (14.4kbps)
Modem Performance	V.34 (33kbps) via POTS, up to V.90 (56kbps) via RuralConnect™
RF Performance	
Frequency Range	5.9GHz Options Available 8 sub channels in 5.9 GHz
RF Channels	23dBm in 5.9 GHz
RF Output Power	-93 dBm/256 kbps @10-6 BER -90 dBm/512 kbps @10- 6 BER
Receive Sensitivity	"N" Type Female
External Antenna Port	
Environmental Specifications	
Operating Temp	-30 to +60 Degrees C (Ambient with Solar Shielding)
Humidity	0 to 90% - Non-Condensing
Voltage Requirements	Filtered DC nominal 12 to 24 V Negative Earth Ground 2 Watts Minimum, 8 Watts Maximum Configuration
Operating Current	
CPE Terminal (FXS) Specifications	
Regulatory	LSSGR, TR57, ITU Q.552, and G.712 36 to 48V
Open Loop Voltage	20 mA to 24 mA
Loop Current	1200 Ohms Including Instrument 60 VAC RMS
Maximum Loop Length	3 REN
Ringing Voltage	Balanced Sinusoidal, 20 Hz Standard, Factory Programmable 16 to 33Hz
Ringing Load	0.0 dBm0, Factory Programmable
Ringing Waveform	-2.0 dBm0, Factory Programmable 24 dB min.
Nominal Transmit Level	Filtered DC Nominal 12 to 24V
Nominal Receive Level	
2 Wire Port Return Loss	1.4 Watts (i.e. 24v @ 60ma) Idle, 4 Watts (i.e. 24v @ 200ma) max Including Radio
Voltage Requirements	
Operating Current: No Load, Full Load	
Base Unit Specifications	
Regulatory	TIA/EIA/IS-968 (FCC), UL 1950, UL 60950, EN 60950, IEC60950, EN55022B 1500 ohms or 18 ma. 0.3B per line
Maximum Loop Length	24-110Vrms, 17-34 Hz 24dB min.
Ring Equivalent Number	Filtered DC Nominal 12 to 24V
Ring Detect Threshold	Less then 2 Watts (i.e. 24v @ 200ma) with 8 Lines Active Including Radio
2 Wire Port Return Loss	
Operating Voltage	
Operating Current: No Load, Full Load	
Certifications	
US, Canada, Brazil, Mexico, Philippians' Islands, Morocco 1 Year Parts and Labor	
Warranty	

6.2.1 Block Diagram

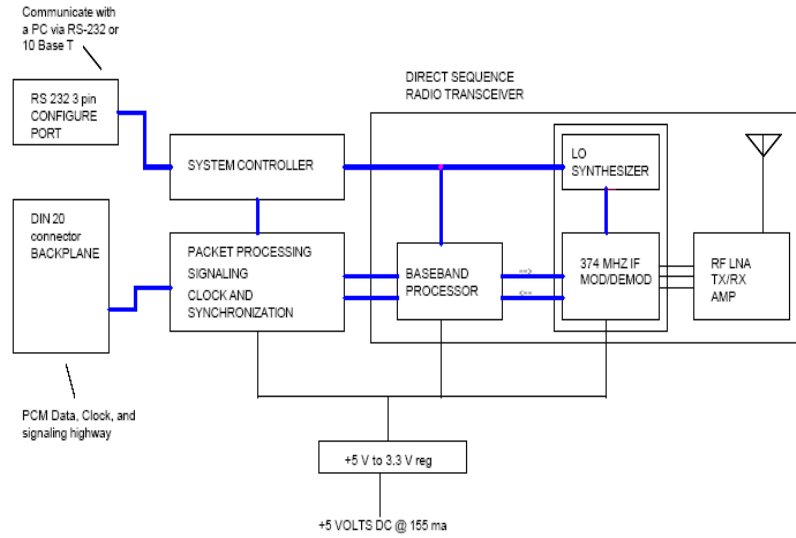

Figure 12: Block Diagram of Radio Card

6.3 Cable Pin outs

Should you misplace or lose your serial programming cable, you can call your CWT sales rep. and order a replacement or construct a new cable from a few simple parts using the diagram below.

6.3.1 Configuration Port Pinout

<i>Configuration Port Cable Construction Table</i>	
A DB9 pin Female to be fit in the PC is wired with:	A 3 pin, .100" spacing connector, female, connecting to the Trailblazer as shown:
DCD on pin 1, (not used)	
TX Data on pin 2,	TX Data on pin 1,
RX Data on pin 3,	RX Data on pin 3,
DTR on pin 4, (not used)	
SG on pin 5, (signal ground)	SG on pin 2, (signal ground)
DSR on pin 6, (not used)	
RTS on pin 7, (not used)	
CTS on pin 8, (not used)	
RI on pin 9, (not used)	

Table 10: Configuration Port Cable Construction Table

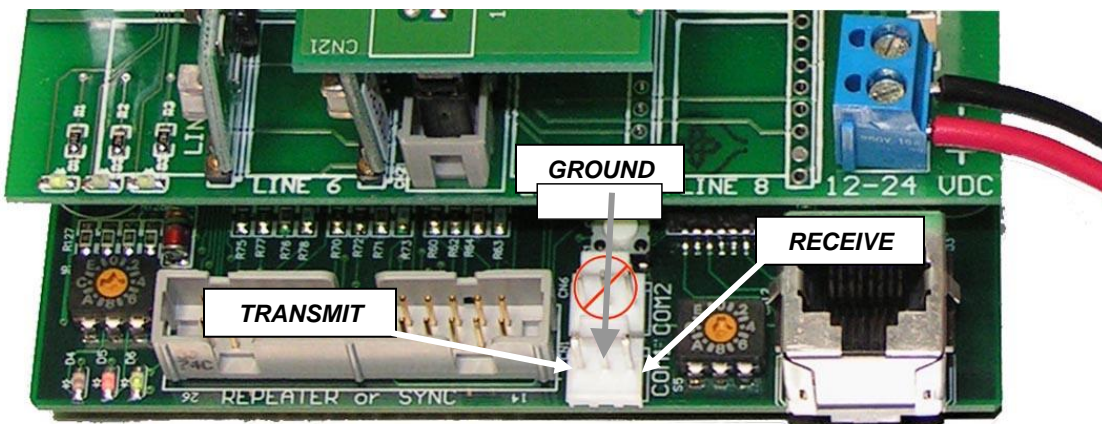

Figure 13: Serial Data Cable Pinout (PCB View)

Standard “AT” Pinout for a DB9 Connector

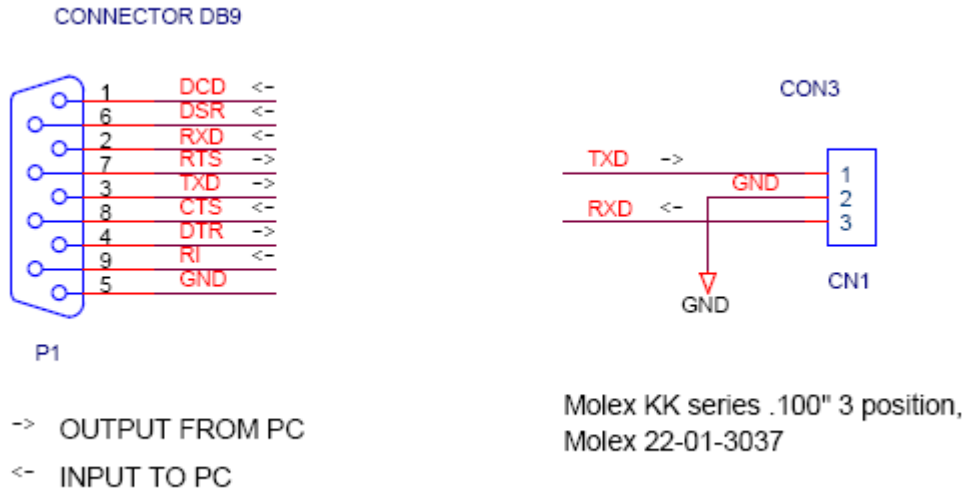

Figure 14: Serial Data Cable Schematic

Serial Data Cable Pinout			
Pin	Signal	Description	Direction
1	DCD	Data Carrier Detect	To PC
2	RD	Receive Data	To PC
3	TD	Transmit Data	From PC
4	DTR	Data Terminal Ready	From PC
5	GND	Signal Ground	Common
6	DSR	Data Set Ready	To PC
7	RTS	Request to Send	From PC
8	CTS	Clear to Send	To PC
9	RI	Ring Indicator	To PC

Table 11: Serial Data Cable Pinout

6.4 Advanced Programming and Diagnostics

6.4.1 Configuring the Serial Port Parameters

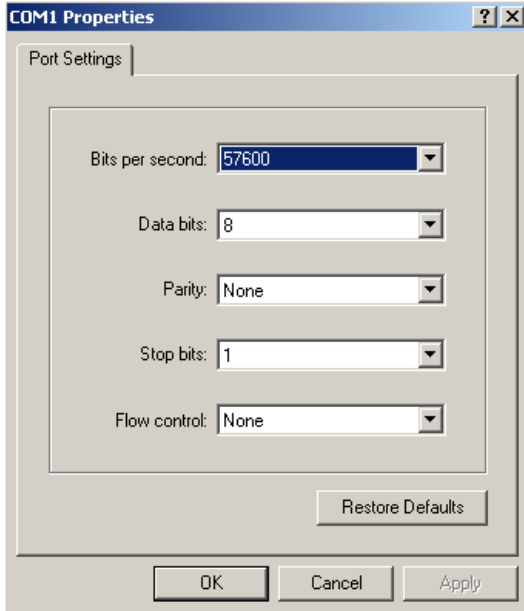

In order to communicate with the Trailblazer units using the Command Line Interface, the serial port parameters need to be configured. The serial port parameters are illustrated in the following figure.

These settings were configured within the program by Hilgraeve (see left and below). This program is readily available and runs on any Windows platform, but any terminal emulation program can be used that can communicate across the asynchronous serial COM ports of a PC.

The ASCII setup screen in HyperTerminal™ needs to be configured well in order to properly communicate with Trailblazer units. In addition to the basic ASCII setup (shown right) which you will most to configure the system, you must a 50ms **line delay** in order to be able to scripts to the Trailblazer units. Scripts are you will need to use in order to configure amount of and allocation of bandwidth within the Trailblazer system. See Section *Allocating Bandwidth to Voice and/or Data* complete details.

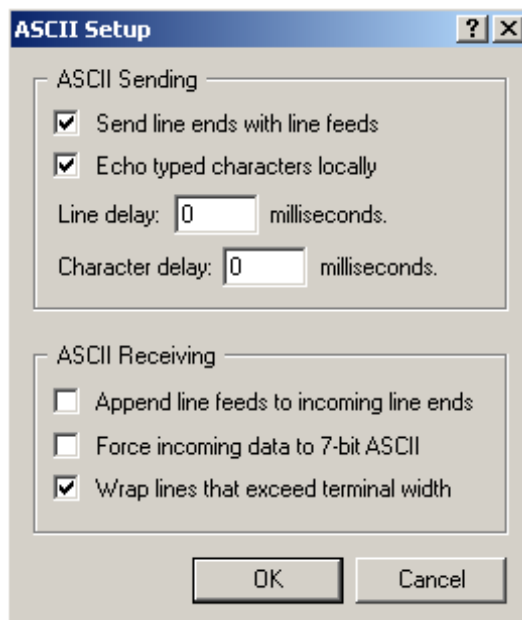

as the use insert send what the 3.4 for

6.4.2 Setting the V35 enable and port location

To enable the V35 data port, open up the Hyperterminal™ interface and if you are communicating with a CPE unit after booting type: **[stop]**. If you connected to a base unit it will stop on it's own after a minute.

Then type in:

[wee 5 1] or **[wee 5 2]** depending on which line no you wish to be used as a data path the Ethernet connection. The system should respond back with: **0005: 02** as shown above.

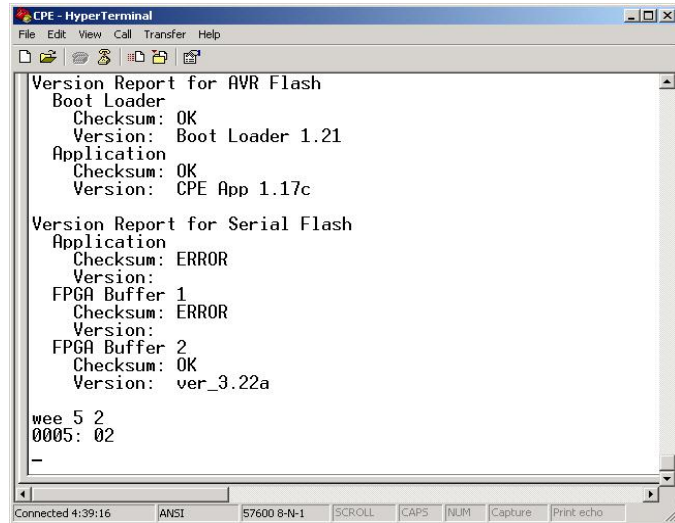

```
CPE - HyperTerminal
File Edit View Call Transfer Help
Version Report for AVR Flash
Boot Loader
Checksum: OK
Version: Boot Loader 1.21
Application
Checksum: OK
Version: CPE App 1.17c
Version Report for Serial Flash
Application
Checksum: ERROR
Version:
FPGA Buffer 1
Checksum: ERROR
Version:
FPGA Buffer 2
Checksum: OK
Version: ver_3.22a
wee 5 2
0005: 02
-
```

are

for

To disable theV35 data port, open up the HyperTerminal™ interface and type in:

[wee 5 FF] . The system should respond back with: **0005: FF** .

6.4.3 Received Signal Strength Indicator (RSSI)

The RSSI value can be accessed through the Command Line Interface using the following command:

rdm ff28 4 <enter>.

The figure at right shows the output for the RSSI from the CPE unit. The RSSI value is repeated times, but just look at a single number. The figure to the right shows an RSSI of 0C. The RSSI should be 8 or higher. If the value displayed contains an alphabetic character (A, B, C, D, E or F), the value is greater than 9. The undesirable RSSI values are from 00 to 07.

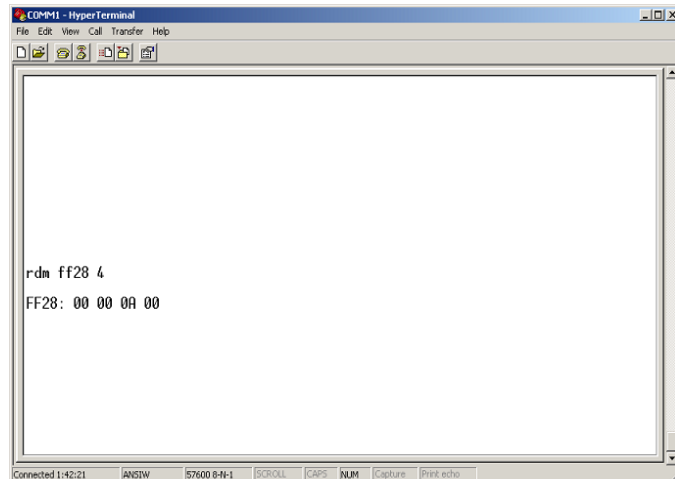

```
COMM1 - HyperTerminal
File Edit View Call Transfer Help
rdm ff28 4
FF28: 00 00 0A 00
```

4

The RSSI command can be used on the base unit. The above figure displays the results of the command. 3 of the 4 values will always read 00, just ignore these values. 1 of the 4 numbers should be greater than 7. If the value displayed contains an alphabetic

character (A, B, C, D, E or F), the value is greater than 9. In the above example the RSSI value is sufficient.

6.4.4 Air Link Quality

The quality of the Air Link can be interrogated through the Command Line Interface using following command: debug 1 <enter>. This command causes Air Link statistics to be printed every 4 seconds. The statistics be stopped by typing, debug 0 <enter>. The processing of the debug command is illustrated in following figure.

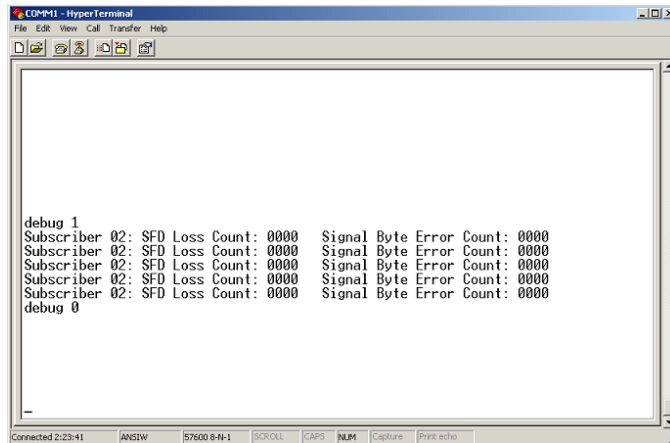

the
the
can
the

With a completely clean link, the SFD Loss Count and Signal Byte Error Count should be both zero. A SFD Loss Count greater than (6) could indicate a low signal strength or external interference.

6.4.5 Installation of Software/Firmware Upgrades

In addition to maintenance using GUI software, as a failsafe the software/firmware for the Trailblazer systems can be upgraded in the field through the serial port using a terminal emulation program and the Command Line Interface.

1. Reset the board using the RESET button near the rotary channel switch.
2. Stop the program through the Command Line

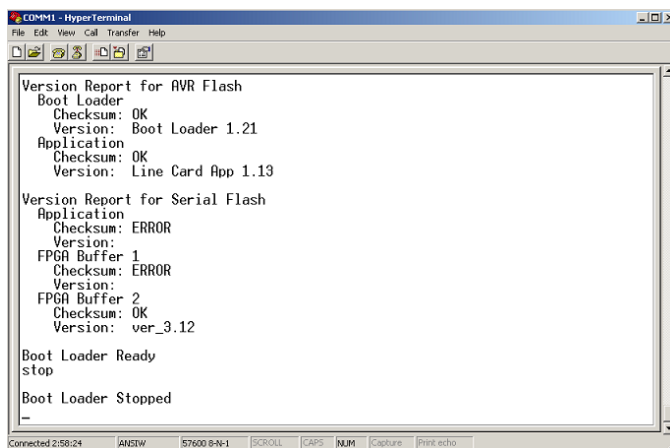

the

Interface. The figure above illustrates this step. When the Boot program starts, the software version information is displayed. When the prompt “Boot Loader Ready” appears, type: [stop] and press: <enter>. The Boot program confirms the stop command by displaying the text “Boot Loader Stopped”. If the text “Boot Loader Stopped” is *not* displayed immediately, RESET the unit and try again. Although timing is not *extremely* critical, try to type the command in the first couple of seconds.

- Download the new software/firmware program. The following two figures illustrate this step. The menu option “Send Text File ...” is selected. Next, the dialog box will appear which allows the selection of the file to download to the Trailblazer unit. After the file is selected, click the “Open” button. The download will proceed automatically from this point.

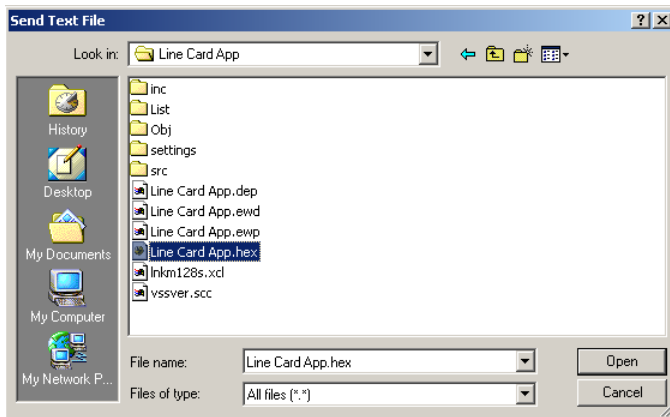
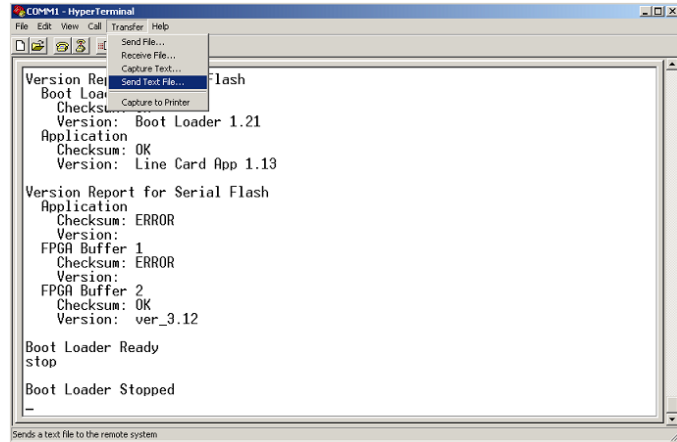

- Download has completed. The end of the download is illustrated below. The version information at the end of the download will indicate the successful completion of the download. Re-display the version information again by typing <versions>.

- Reset the board either manually using the reset button or by typing <reset>. The Trailblazer unit will need to be reset before the new software/firmware upgrade will take effect.

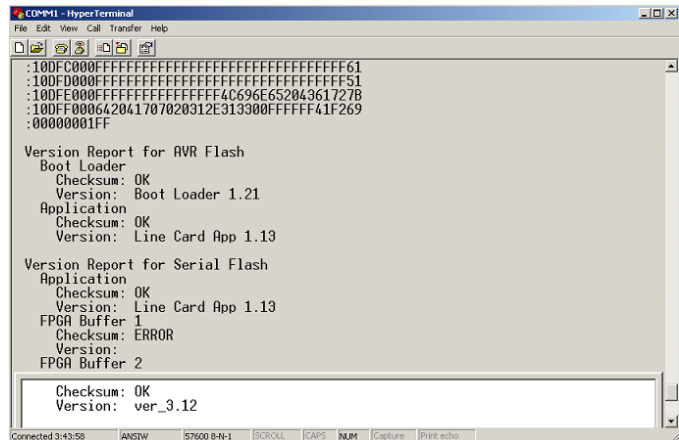

6.5 Antenna Patterns and Specifications

6.5.1 16dBi Directional Panel Plots and Specs

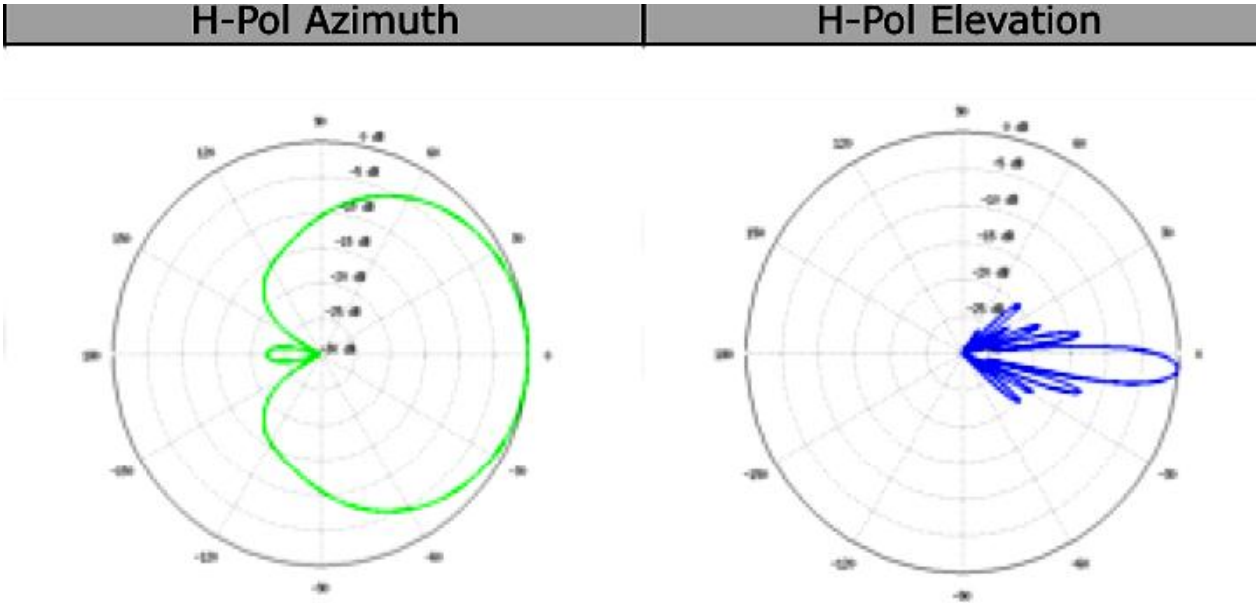

16dBi Directional Panel Specifications					
Pole Size		1.5" (38)	to	3" (76)	In (mm)
Weight		2.4 (1.1)			Lbs. (kg)
Dimension (W x L)		14.45 x 2.5 x 16 (367x63x41)			In (mm)
Wind Load		120			MPH
Frequency Range		5100-5900			MHz
Hpol Beamwidth (6dB)		137 deg.			deg
Vpol Beamwidth (6dB)		119 deg			deg
VSWR		1.5:1			
Elevation Beamwidth		8 deg.			deg
Electrical Downtilt		4 deg			deg
Polarization		Dual Linear			.
Cross – Pol Isolation		22. dB min			
Gain		15.0 – 16.0			dBi
ETSI Specification		EN 302 326 DN2			

Table 12: 16dBi Directional Panel Specifications

6.6 Warranty

Limited Warranty, USA

Carlson Wireless Technologies Inc. (CWT) or Carlson Wireless USA, collectively referred to as "Carlson", will repair this product with new or rebuilt parts, free of charge, in the USA or Puerto Rico for one (1) year from the date of original purchase in the event of a defect in material or workmanship. Mail-in service in the USA can be obtained during the warranty period from a Carlson Factory Service center by calling +1.707.822.7000 or online by visiting http://carlsonwireless.com/service/rma_request.php for an RMA (Return Materials Authorization) number. After receiving your RMA confirmation via telephone or email, ship your product adequately packed, postage paid and insured to the address provided. This warranty extends to the original purchaser only. A purchase receipt or other proof of the date of original purchase will be required before warranty services are rendered. This warranty only covers failures due to defects in materials or workmanship which occur during normal use. It does not cover damages incurred in shipment or failures caused by products not supplied by Carlson. It also does not cover failures which result from accident, misuse, abuse, neglect, mishandling, misapplication, alteration, modification, lightning, power line surge, introduction of sand, dust, humidity and/or liquids, or service by anyone other than a Carlson Factory Service Center or authorized Carlson Service Center, or damage that is attributable to acts of God.

Limits and Exclusions

There are no express warranties except as listed above.

CARLSON SHALL NOT BE LIABLE FOR INCIDENTAL OR CONSEQUENTIAL DAMAGES RESULTING FROM THE USE OF THIS PRODUCT OR ARISING OUT OF ANY BREACH OF THIS WARRANTY. ALL EXPRESS AND IMPLIED WARRANTIES, INCLUDING THE WARRANTIES OF MERCHANTABILITY AND FITNESS FOR A PARTICULAR PURPOSE, ARE LIMITED TO THE APPLICABLE WARRANTY PERIOD SET FORTH ABOVE.

Some states do not allow the exclusion or limitation of incidental or consequential damages or limitations on how long an implied warranty lasts, so the above exclusions or limitations may not apply to you. This warranty gives you specific legal rights and you may also have other rights which vary from state to state. If a problem with this product develops during or after the warranty period you may contact your dealer or Service center.

6.7 Acronyms/Abbreviations

ANSI	American National Standards Institute
async	asynchronous
CCITT	Comité Consultatif International Téléphonique et Télégraphique
CD	carrier detect
CPE	customer premise equipment
CS	clear to send
CSU	channel service unit
CTS	clear to send
CO	central office
dB	decibel
DCE	data communications equipment
DDS	digital data service
DSR	data set ready
DSU	data service unit
DTE	data terminal equipment
DTR	data terminal ready
EA	extended address
FR	frame relay
FSU	frame relay service unit
GUI	graphical user interface
HDLC	high-speed data link control
IP	internet protocol
ISDN	integrated services digital network
ITU	International Telecommunications Union
kbps	kilobits per second
LAN	local area network
LED	light emitting diode
MIB	management information base
ms	millisecond
PPP	point-to-point protocol
RD	receive data
RDL	remote digital loop-back
RFC	request for comments
RIP	routing information protocol
RMA	return material authorization
RR	receiver ready
RTS	request to send
Rx	receive
SDLC	synchronous data link control
SNA	systems network architecture
SNMP	simple network management protocol
SW56	switched 56
sync	synchronous
TD	transmit data
TR	data terminal ready
Tx	transmit
UNI	user-to-network interface
WAN	wide area network

6.8 Glossary

ANSI

Acronym for American National Standards Institute. Devises and proposes recommendations for international communications standards.

asynchronous

A method of data transmission which allows characters, that are preceded by a start bit and are followed by a stop bit, to be sent at irregular intervals.

bandwidth

A range within a band of frequencies or an amount of data that can be transmitted in a preset amount of time. The bandwidth determines the rate at which information can be sent.

bridge

A connectivity advice that operates at the OSI Data Link Layer and filters and forwards packets by physical addresses. See also router.

CD

Acronym for Carrier Detect. It is a signal generated by a modem or DSU/CSU and indicates the presence of a carrier signal on a communications link.

CSU

Acronym for Channel Service Unit. A device used to connect a digital phone line from the phone company to a multiplexer, channel bank, or directly to another device producing a digital signal. A CSU performs line-conditioning and equalization functions, responds to loop-back commands sent from the central office, regenerates digital signals and monitors them for problems, and provides a way of testing a digital circuit.

CLASS features

Acronym for Custom Local Area Signaling Services. Consists of number-translation services, such as call-forwarding and caller identification.

clock

Is an oscillator-generated signal that provides a timing reference and generates periodic signals for the timing of certain functions in a transmission link.

CPE

Acronym for Customer Premise Equipment. It includes all telecommunications terminal equipment located on the customer premises, including telephone sets, PBXs, data terminals, and customer-owned coin-operated telephones.

CTS

Acronym for Clear To Send. A signal on the DTE interface indicating that the DCE is clear to send data.

dB

Is an abbreviation for decibel, a logarithmic unit used to measure sound level or signal strength.

DCE

Acronym for Data Communications Equipment. A device that provides all the functions required for connection to telephone company lines and for converting signals between telephone lines and DTE. Also see DTE.

DSR

Acronym for Data Set Ready. It is a signal on the EIA-232 interface that indicates a connection and readiness to start handshaking control signals for communication to begin.

DSU

Acronym for Data Service Unit. A hardware component needed to transmit digital data over a hardware channel. It converts signals from bridges, routers, and multiplexers into the bipolar digital signals used on the telephone company digital lines and ensures that voltage levels are correct.

DSU loop back

Is a Telco initiated test which loops the DSU back to the Telco and is used to test the DDS circuit as well as the DSU/CSU.

DTE

Acronym for Data Terminal Equipment. It is the end-user terminal or computer that plugs into the termination point (DCE) of a communications circuit.

gateway

Is a device which enables information to be exchanged between two dissimilar systems or networks.

HDLC

Acronym for High Level Data Link Control. It is a generic link-level communications protocol developed by ISO, that manages synchronous code-transparent serial information transfer over a link connection. See also SDLC.

host computer

The primary or controlling computer in a multiple computer operation.

in-band signaling

is signaling over the same channel used for data.

IP

Acronym for Internet Protocol. It provides for transmitting blocks of data between hosts identified by fixed-length addresses.

ISDN

Acronym for Integrated Services Digital Network. It is a network architecture that enables end-to-end digital connections. It supports diverse services through integrated access arrangements and defines a limited set of standard, multipurpose interfaces for equipment vendors, network providers, and customers.

LAN

Acronym for Local Area Network. A privately owned network that offers high-speed communications channels connecting information processing equipment in a limited geographic area.

MIB

Acronym for Management Information Base. It is a database of network management information used by SNMP.

multi-point

Is a configuration or topology designed to transmit data between a central site and a number of remote terminals on the same circuit. Individual terminals are not able to send data to each other.

out-of-band signaling

Is signaling that is separated from the channel carrying information (voice, data, video, etc.) by a filter.

packet

Is a bundle of data that contains both control information and the data itself. The control information is used for routing the packet through a network to its final destination.

packet-switching network

Is a telecommunications network based on packet-switching technology, wherein a transmission channel is occupied only for the duration of the transmission of the packet.

parameter

Is a numerical code that controls an aspect of terminal and/or network operation. Parameters control page size, data transmission speed, and timing options.

ping

Is an internet protocol standard that provides loop-back on demand for any device in an IP network. One device "pings" another by sending a loop-back request to the device's IP address.

point-to-point

Is a type of communications link that connects a single device to another single device, such as a Base unit to a CPE unit.

remote configuration

A feature that allows the CPE unit to be configured from the Base unit or VT-100 compatible terminal.

router

Is a device that supports LAN-to-LAN communications. It reads logical addressing information and directs data across a network to its destination. See also bridge.

SNMP

Acronym for Simple Network Management Protocol. It is a control and reporting scheme widely used to manage devices from different vendors and operates on top of the Internet protocol.

switched network

Is a network of dial-up telephone lines that uses circuit switching to provide communications services to network users.

synchronous

A method of data transmission in which timing information is sent along with the transmitted data. Synchronous communication is achieved when timing shares a single clock.

SDLC

Acronym for synchronous data link control. A link-level communications protocol that manages synchronous, code-transparent, serial information transfer over a link connection.

TELNET

The standard TCP/IP remote login protocol

VT-100

A non-intelligent terminal or terminal emulation mode used for asynchronous communications.