

Copper Maxx, Carrera® Profi®

Red Fibre, Carrera® Profi®

Fibre Monster, Carrera® Profi®

Power Rider, Carrera® Profi®

#370183001

#370183002

#370183003

#370183004

Carrera®

PROFI RC

- D** Montage- und Betriebsanleitung
- GB USA** Assembly and operating instructions
- F** Instructions de montage et d'utilisation
- E** Instrucciones de montaje y de servicio
- I** Istruzioni per il montaggio e l'uso
- NL** Montage- en gebruiksaanwijzing
- P** Instruções de montagem e modo de utilização
- S** Monterings- och bruksanvisning
- FIN** Asennus- ja käyttöohje
- PL** Instrukcja montażu i obsługi
- H** Szerelési és használati utasítás
- SLO** Navodila za montažo in uporabo
- CZ** Návod k montáži a obsluze
- SK** Návod na montáž a obsluhu
- HR** Uputa za montažu i uporabu
- N** Montajse- og bruksanvisning
- DK** Monterings- og driftsvejledning
- TR** Montaj ve işletme kılavuzu
- Arabic** إرشادات التركيب و الأستخدام

RCPower

carrera-rc.com

Made in China, Shantou



Sicherheitsbestimmungen · Safety instructions · Consignes de sécurité
 Disposiciones de seguridad · Norme di sicurezza · Veiligheidsbepalingen
 Prescrições de segurança · Säkerhetsbestämmelser · Turvallisuusohjeet
 Zasady bezpieczeństwa · Biztonsági rendelkezések · Varnostna določila
 Bezpečnostní předpisy · Bezpečnostné predpisy · Sigurnosne odredbe
 Sikkerhetsbestemmelser · Sikkerhedsbestemmelser · Emniyet kaideleri

أنظمة السلامة

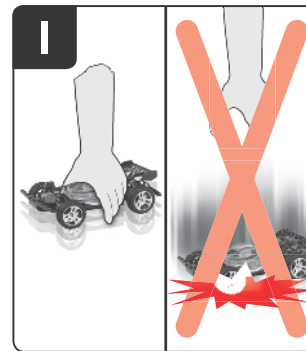
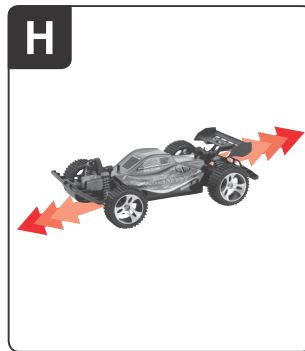
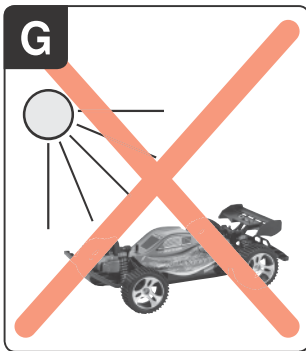
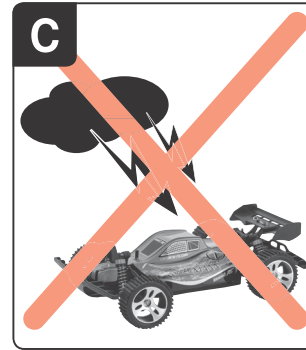
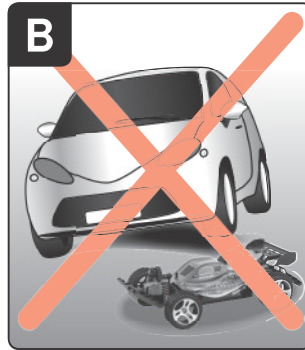

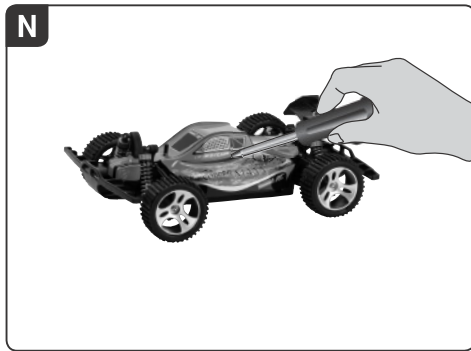
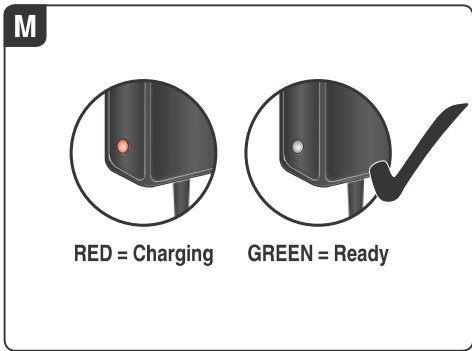
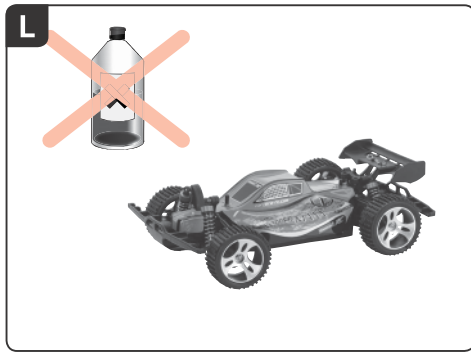
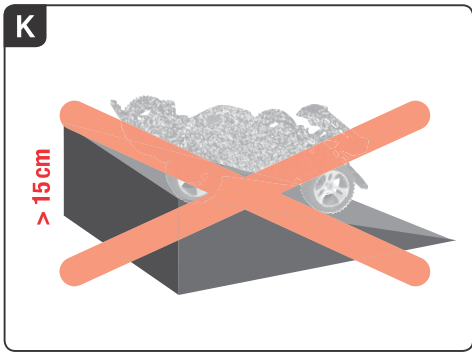



1

1x 8,4 V
1000 mA!

1x 7,4 V
1100 mA
8,14 Wh!

2x 1,5 V
Mignon AA
Battery

* Nur ein Modell enthalten - Contains only one model - contient un seul modèle - Contiene sólo un modelo - Contiene un solo modello no - Bevat slechts één model Contém só uma miniatura - Endast en modell - Sisältää vain yhden radio-ohjattavan - Zawiera tylko jeden model - Csak egy modell tartalmaz - Vključuje samo en model Obsahuje pouze jeden model - Inneholder kun samme modell - Indeholder kun én model - Περιέχει μόνο ένα μοντέλο - 含一个模型 - モデルは1体のみ入っています - 모델 한 개만 들어있음 - لا يحتوي إلا على نموذج واحد فقط - Sadece tek modeli dahildir - В объеме поставки входит только одна модель

2

1x 7,4 V
1100 mA
8,14 Wh!

O.K.

3

2x 1,5 V
Mignon AA
Battery

4

5

6

7

ON / OFF

8

ON
OFF

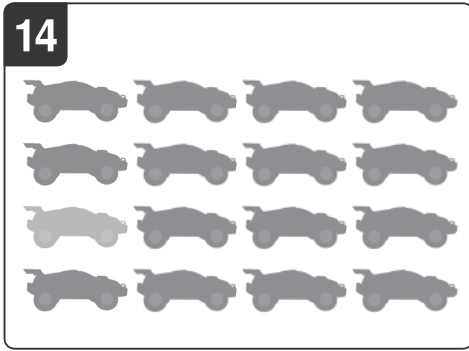
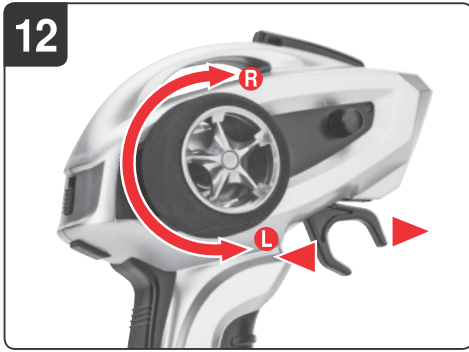
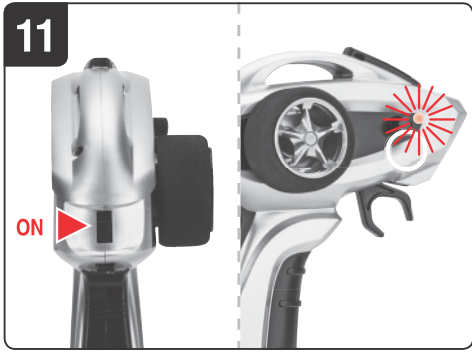
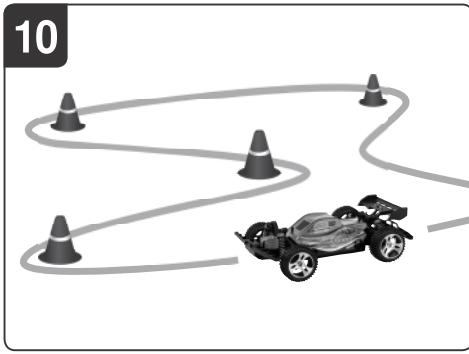
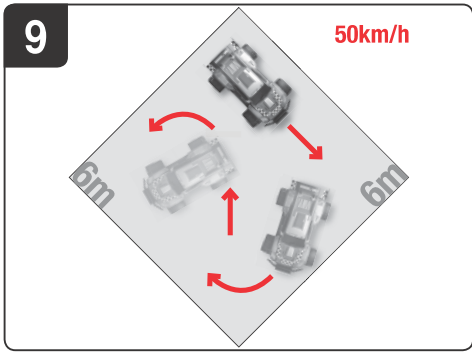

Problemlösungen

Problem

Modell fährt nicht.

Ursache: Schalter am Controller oder/und Modell steht/stehen auf „OFF“.

Lösung: Einschalten.

Ursache: Schwacher oder gar kein Akku im Modell.

Lösung: Geladenen Akku einlegen.

Ursache: Das Auto ist an einem Hindernis stehen geblieben.

Lösung: Der Überspannungsschutz hat das Auto abgeschaltet. ON/OFF Schalter am Fahrzeug einmal auf OFF, dann wieder auf ON schalten und auf einer freien Fläche platzieren.

Ursache: Schwacher Akku/Batterie im Controller oder Modell.

Lösung: Geladenen Akku oder Batterie einlegen.

Ursache: Das Fahrzeug ist sehr warm.

Lösung: Fahrzeug und Controller ausschalten und das Fahrzeug etwa 30 Minuten abkühlen lassen.

Ursache: Der Überhitzungsschutz hat das Auto wegen zu starker Erwärmung angehalten.

Lösung: Den Empfänger ausschalten Das RC-Fahrzeug etwa 30 Minuten abkühlen lassen.

Problem

Keine Kontrolle.

Ursache: Fahrzeug setzt sich ungewollt in Bewegung.

Lösung: Stellen Sie wie unter „Einsetzen des Akkus“ 7 8 beschrieben, eine Bindung zwischen Modell und Controller her.

Irrtum und Änderungen vorbehalten

Farben/ endgültiges Design – Änderungen vorbehalten

Technische und designbedingte Änderungen vorbehalten

Piktogramme = Symbolfotos



Dear customer

Congratulations on purchasing a Carrera RC model car, manufactured in accordance with the latest technology. As it is our constant endeavour to develop and improve our products, we reserve the right to make modifications, either of a technical nature or with respect to features, materials, and design, at any time, and without prior notice. For this reason, no claims will be accepted for any slight deviations in your product from the data and illustrations contained in these instructions. These operating and assembly instructions are an integral part of the product. Non-observance of these operating instructions and the safety instructions they contain will render the guarantee null and void. These instructions are to be kept for future reference and in the event that the product is passed on to a third party.

For the latest version of these operating instructions and information on replacement and spare parts available, please visit carrera-rc.com in the service area.

Guarantee conditions

A Carrera product is built to high technical standards and is to be treated with care. Please ensure that you observe all the instructions contained in this guide. All components have been subjected to careful inspection (technical modifications and alterations to the model for the purpose of product improvement are reserved).

Should any faults nevertheless occur, guarantee is assumed within the scope of the following conditions:

The guarantee covers demonstrable material or manufacturing defects that existed at the time that the Carrera product was purchased. The guarantee period is 24 months beginning with the date of purchase. The guarantee does not extend to wearing parts (such as Carrera RC rechargeable batteries, antennas, tyres, gearbox components etc.), damage caused by improper treatment or use (such as performing jumps in excess of the recommended height, dropping the product etc.), or unauthorised intervention. Repair may only be performed by Stadlbauer Marketing + Vertrieb GmbH itself or by a company it has authorised to do so. Within the scope of this guarantee, either the product as a whole or only the defective components will be replaced or equivalent substitution performed, as deemed appropriate by Stadlbauer Marketing + Vertrieb GmbH. The guarantee does not cover transport, packaging or travel costs or any damage for which the buyer is responsible. These costs are to be covered by the buyer. Guarantee claims will only be accepted from the original purchaser of the Carrera product.

Guarantee claims can only be accepted when:

- The card has been filled in properly and sent in together with the defective Carrera product and the purchase receipt/invoice/cash-register receipt.
- No unauthorised alterations have been made by the buyer to the guarantee card.
- The toy has been treated in accordance with the operating instructions and subjected to its intended use.
- The damage/faulty operation is not due to acts of God or normal wear and tear.

Guarantee cards cannot be replaced.

Note for EU countries: Reference is hereby made to the seller's statutory guarantee obligation, to the extent that this guarantee obligation is not restricted by the product guarantee.

Declaration of conformity

Stadlbauer Marketing+Vertrieb GmbH hereby declares that this model including the controller conforms with the fundamental requirements of the following EC directives: EC Directives 2009/48/EC and 2014/30/EU regarding electromagnetic compatibility and the other relevant regulations of Directive 2014/53/EU (RED). The original declaration of conformity can be requested from carrera-rc.com.



Maximum radio-frequency power transmitted <10 dBm

Warning!

This remote-controlled model is NOT A PLAYTHING and is only suitable for young people over 14 years of age. This model is not intended for use by children, unless they are supervised by a responsible adult. Inappropriate use may result in severe injuries and/or damage to property. It has to be operated with care and caution and requires both mechanical and mental skills. The operating instructions contain notes on safety and technical regulations as well as information on maintaining and operating the product. It is indispensable to read these instructions thoroughly before the first usage. Only this helps to avoid accidents with injuries and damage.



This symbol, showing refuse bins with a cross through them, denotes that empty batteries, rechargeable batteries, button cells, rechargeable battery packs, equipment batteries, disused electrical equipment, etc. should not be disposed of in domestic refuse, as they are harmful to the environment and health. Please help to preserve environment and health and talk to your children about the correct disposal of used batteries and disused electrical equipment.

Batteries and disused electrical equipment should be handed in to the usual collection points where they can be properly recycled.

Do not mix dissimilar battery types or employ new and used batteries together. Empty batteries should be removed from the product. Do not recharge non-rechargeable batteries due to risk of explosion.

WARNING! Rechargeable batteries are only to be charged by adults.

Never leave the battery unattended while it is charging. Exhausted batteries are to be removed from the toy. Rechargeable batteries should be removed from the product before charging. Supply terminal are not to be short-circuited. Only use the batteries recommended or equivalent types. If in regular use the charger must be examined for damage to the cord, plug, covers and all other parts. If any signs of damage are found the charger may only be used again after repair work has been com-

pleted. The external flexible cable or cord of this charger cannot be replaced: If the cord is damaged the charger shall be scrapped.

FCC statement

This device complies with Part 15 of the FCC Rules. Operation is subject to the following two conditions:

- (1) this device may not cause harmful interference, and
 - (2) this device must accept any interference received, including interference that may cause undesired operation.
- Changes or modifications not expressly approved by the party responsible for compliance could void the user's authority to operate the equipment.

Safety instructions

A A Carrera RC vehicle is a remote-controlled model car that uses special rechargeable batteries for this purpose. Only original Carrera RC Li-Ion rechargeable batteries may be used. Rechargeable batteries are to be removed from the toy before being charged.

B The Carrera RC vehicle is designed for hobby use only and may only be operated on tracks and in spaces especially intended for this purpose.

WARNING! Do not use the Carrera RC vehicle in road traffic.

C Do not operate the car beneath overhead high-voltage cables or broadcasting masts or during a storm! Atmospheric disturbances can affect the operation of the vehicle. When there are large temperature differences between your car's garage and the running track, please wait until the vehicle has had time to acclimatise. This will help prevent condensation forming and the possibility of malfunctions resulting.

D Never operate the product on grass surfaces. There is the risk of grass hindering the movement of the axles, which can lead to the motor overheating. Do not use the Carrera RC vehicle for transporting goods, persons or animals.

E Never use the Carrera RC vehicle outdoors during rain or snowfall. The car must not be run through water, puddles and snow, and must always be kept stored in a dry place. Wet surfaces without puddles will not affect the car's performance as the electronic equipment is protected against spray.

F Never operate the vehicle near rivers, ponds or lakes, to avoid the risk of the Carrera RC car falling into the water. Avoid running on courses which are laid exclusively with sand.

G Do not expose the Carrera RC vehicle to direct sunlight. To avoid the electronics in the car overheating, when temperatures are above 35°C, regular short pauses in operation are essential.

H Never subject the Carrera car to repeated changes of load – that means continuously reversing it.

I Always place the car on the floor by hand. Never throw the car on the floor from a standing position.

K Avoid jumping from jumps or ramps higher than 15 cm (0.49 ft.).

L Never use strong solvents for cleaning the car.

M To avoid malfunctions to the control system resulting in uncontrolled operation of the Carrera RC vehicle, check that the controller batteries and the rechargeable batteries in the vehicle have sufficient charge. Supply terminals are not to be short-circuited.

N The Carrera RC vehicle must be inspected before and after operation, each time it is used, to ensure that it has not become disassembled. Any screws or nuts that may have become loosened during operation must be tightened.

Instruction Manual

Contents of package

- 1 1x Carrera RC Vehicle
- 1x Controller
- 1x Battery Charger
- 1x Rechargeable Battery
- 2x 1.5 V Mignon AA batteries (non-rechargeable)

Charging the rechargeable battery

2 First connect the Carrera RC rechargeable battery to the battery charger supplied. The connection terminals between the battery and the charger are designed to prevent connection with the wrong polarity. Connect the charger to a power source.

When the battery is properly connected and charging normally, the red LED is constantly lit. Once the battery is fully charged, the red LED switches to green. The battery can now be disconnected and installed in the Carrera RC car. The car is now ready for use.

Always recharge the battery after use to prevent its becoming deep discharged. After use, the battery must be allowed to cool down for at least 20 minutes before it can be fully recharged. Failure to observe this pause may damage the battery. Recharge the battery occasionally (suggested every 2–3 months). Failure to treat the battery as described above can lead to its becoming defective.

Inserting the batteries

3 Open the battery compartment with a screwdriver. Press the release button and take the battery compartment out of the controller. Please keep in mind the correct polarity. Different types of batteries or new and used batteries are not to be mixed. Push the battery compartment back into the controller until it latches in place. If necessary, screw the battery compartment in place with a screwdriver.

Installing the rechargeable battery

4 Undo the two clips on the top of the bodywork to remove it.

5 Connect the end of the cable from the Carrera RC vehicle with the charged battery.

6 Fasten the rechargeable battery and the cable in the mount as shown in the illustration.

7 Switch the car ON at the ON/OFF switch. The LED on the car will flash rhythmically.

8 Switch on the controller. After a few seconds, the LEDs on the car and on the controller will light continuously, meaning the bind has been made.

Fasten the bodywork again with the two clips.

Let's practise!

9 **Warning! This vehicle reaches speeds up to 50 km/h (31 mph).** Practice on an empty surface at least 6 metres (19.68') square. **When first starting, be very careful when operating the gas pedal.** Practice running slowly for at least two to three full charges of the battery before you start practising faster manoeuvres.

10 Now it's time to practise! Set up a Carrera RC vehicle racing track in a large empty area, using cornerposts, empty cans, or similar objects. The basic technique to adopt when operating a Carrera RC is to drive fast on the straight sections and to slow down in the curves.

- **When changing from the first battery to the second battery, you must stop running for at least ten minutes. At the next change, a pause of at least 20 minutes is absolutely essential.**
- **Avoid constant motor operation.**
- **If the car switches itself off several times one after another, the battery is dead. Please recharge the battery.**
- **To switch off after use, follow the steps in the reverse order.**
- **After use, remove or disconnect the battery. Always recharge the battery after use to prevent its becoming deep discharged. After use, the battery must be allowed to cool down for at least 20 minutes before it can be fully recharged.**

- Always keep the rechargeable battery stored outside the vehicle.
- Clean the Carrera RC car after use.

Controller functions

11 When the controller is switched on, the red LED lamps at the front of the controller are lit.

12 **Control digital proportional**
Gas pedal to the rear; forwards
Gas pedal to the front: braking, or backwards
Turn the steering wheel clockwise: right
Turn the steering wheel anti-clockwise: left
Please note that for reasons of safety, the maximum speed in reverse is about 40 % less.

13 **Steering-TRIMM**
Fine steering adjustment
If the vehicle does not run in a straight line, you can make fine steering adjustments here.

14 Thanks to 2.4 GHz technology, up to 16 cars can be run together on one race-track. This is possible even without harmonising frequencies between the racing drivers.

Troubleshooting

Problem

Car does not move.

Cause: Either the switch on the controller or the car is set to OFF.
Solution: Switch on.

Cause: There is no rechargeable battery in the car or the battery is too weak.
Solution: Insert charged battery.

Cause: The car has come to a stop at an obstacle.
Solution: The voltage surge protector has switched the car off. Turn the ON/OFF switch on the car to OFF, then back to ON, and place the car on a clear surface.

Cause: The battery or rechargeable battery in the transmitter or model is too weak.
Solution: Insert new battery or recharged battery.

Cause: The vehicle is very warm.
Solution: Switch both car and controller off and allow the car to cool down for about 30 minutes.

Cause: The overheat protection has caused the car's motor to shut out due to excess temperature.
Solution: Switch off the receiver. Leave the RC car to cool down for approx. 30 minutes.

Problem

Car cannot be controlled.

Cause: The vehicle starts off on its own.
Solution: Carry out a frequency bind between the model and the remote control as described in Installing the rechargeable battery" **7** **8**.

Errors and changes excepted

Colours / final design – changes excepted

Technical changes and design-related changes excepted

Pictograms = symbolic photos

F

Chère cliente ! Cher client !

Félicitations pour l'achat de votre véhicule radiocommandé Carrera RC fabriqué selon des critères récents des plus exigeants. Nous avons toujours pour ambition d'améliorer et de perfectionner nos produits et nous réservons la possibilité de réaliser des modifications techniques relatives à la présentation et design de nos produits. Les divergences de faible importance du produit, que vous avez acheté, par rapport aux données et illustrations de ces instructions de montage et d'utilisation ne sauraient donner lieu à des réclamations de ce fait. Ces instructions de montage et d'utilisation forment partie intégrale du produit. Le fabricant décline toute responsabilité en cas d'observation des instructions de montage et d'utilisation et des consignes de sécurité y figurant. Veuillez conserver ces instructions de montage et d'utilisation, afin que vous puissiez les consulter ultérieurement et les remettre à tout utilisateur de ce véhicule si besoin est.

Vous trouverez la version la plus actuelle de ce mode d'emploi et les informations sur les pièces de rechange disponibles sur carrera-rc.com dans la zone de service.

Conditions de garantie

Les produits Carrera sont des jouets d'une technique haut de gamme, qu'il est toujours recommandé de traiter avec soin. Respectez impérativement les informations contenues dans les instructions d'utilisation. Tous les éléments sont soumis à des contrôles approfondis (sous réserve de modifications techniques et des véhicules destinées au perfectionnement du produit).

La responsabilité du fabricant est cependant engagée aux termes des conditions de garantie ci-après à supposer que le produit présente des défauts :

La garantie s'applique aux défauts matériels ou de fabrication effectivement existants au moment de l'achat du produit Carrera. La garantie du fabricant s'élève à 24 mois à partir de la date d'achat. Le recours à la garantie du fabricant est exclue pour les pièces d'usure (comme les batteries, antennes, pneus, boîtes de vitesse Carrera RC, etc.), les dommages causés par un traitement / une utilisation non conforme à l'usage prévu (comme par exemple des sauts au-dessus des données de hauteur recommandées, la chute du produit, etc.) ou les interventions de tiers. La réparation demeure réservée au domaine de compétence de la société Stadlbauer Marketing + Vertrieb GmbH ou d'une entreprise dûment autorisée par cette dernière. Dans le cadre de cette garantie, la société Stadlbauer Marketing + Vertrieb GmbH décide au choix du remplacement du produit Carrera complet ou des éléments défectueux ou du remplacement par un produit équivalent. La garantie ne s'applique pas aux frais de transport, d'emballage et de voyage, de même qu'aux dommages découlant de la responsabilité de l'acheteur. Ceux-ci sont à la charge de l'acheteur. Le recours à la garantie est exclusivement réservé au premier acheteur du produit Carrera.

Le recours à la garantie du fabricant est uniquement possible si

- le produit Carrera défectueux est envoyé avec la carte de garantie dûment remplie et le reçu / la facture / le ticket de caisse respectif.
- l'acheteur n'a effectué aucune modification sur la carte de garantie.
- le jouet a été traité dans le respect des instructions de montage et d'utilisation et utilisé de manière conforme à l'usage prévu.
- les dommages / dysfonctionnements n'ont pas été causés par une force majeure ou une usure liée à l'utilisation du produit.

Les cartes de garantie ne sont pas remplaçables.

Avis destinés aux États de l'Union européenne :

nous attirons l'attention sur l'obligation de garantie légale du vendeur, pour autant que cette obligation de garantie ne soit pas restreinte par les conditions de la présente garantie.

Déclaration de conformité

Par la présente la société Stadlbauer Marketing + Vertrieb GmbH déclare que ce modèle y compris le contrôleur est conforme aux exigences essentielles des directives européennes suivantes : Directives européennes 2009/48/EC et 2014/30/EU relatives à la comptabilité électromagnétique et aux autres prescriptions importantes de la Directive 2014/53/EU (RED). L'original de la déclaration de conformité est à votre disposition sur le site internet carrera-rc.com.



Puissance de fréquence radio maximale <10 dBm

Avertissements !

Ce modèle télécommandé N'EST PAS UN JOUET et n'est approprié que pour les adolescents à partir de 14 ans ! Ce modèle n'est pas conçu pour être utilisé par des enfants sans la surveillance d'une personne chargée de l'éducation. Un emploi non conforme peut entraîner de graves blessures et/ou des dommages matériels. Il doit être piloté avec prudence et circonspection et exige certaines facultés mécaniques et mentales. Le mode d'emploi contient des consignes de sécurité et des prescriptions ainsi que des indications sur l'entretien et l'emploi du produit. Il faut impérativement avoir lu complètement et compris ce mode d'emploi avant la première mise en service. C'est la seule manière d'éviter les accidents accompagnés de blessures et de dommages.



Le pictogramme ci-contre des poubelles sur roues barrées est destiné à attirer votre attention sur le fait qu'il est interdit de jeter les piles, accumulateurs, piles rondes, packs d'accus, batteries d'appareils, appareils électriques usagés etc. dans les ordures ménagères, étant donné que ces produits nuisent à l'environnement et à la santé. Veuillez nous aider à sauvegarder l'environnement et la santé et attirez aussi l'attention de vos enfants sur une élimination correcte des batteries, piles et appareils électriques usagés. Remettez les batteries, piles et appareils électriques usagés aux postes de collecte respectifs. Ces postes veilleront à leur recyclage aux termes des réglementations en vigueur. Il est strictement interdit d'utiliser des types différents de batteries ou des piles neuves avec des piles usagées. Retirez toujours les batteries et piles vides du jouet. En raison du risque d'explosion, il est interdit de recharger des piles non rechargeables.



DISTRIBUTORS

AUSTRIA
Stadlbauer Marketing + Vertrieb GmbH
 Rennbahn Allee 1
 5412 Puch / Salzburg - Austria
 Phone +43 662 88 9210
 Fax +43 662 88 921512
 Internet www.carrera-rc.com

GERMANY
Stadlbauer Marketing + Vertrieb GmbH
 Rennbahn Allee 1
 5412 Puch / Salzburg - Austria
 Phone +49 911 7099 0
 Fax +49 911 7099 119
 Internet www.carrera-rc.com

HONG KONG
Stadlbauer (HK) Ltd.
 Room 1917 North Tower
 Concordia Plaza
 1 Science Museum Road
 Tsimshatsui East - Kowloon
 Hong Kong
 Phone +852 2722 0620
 Fax +852 2367 0792
 Internet www.carrera-rc.com

USA / CANADA
Carrera of America Inc.
 2 Corporate Drive
 Cranbury, NJ 08512 - USA
 Phone +1 609 409 8510
 Fax +1 609 409 8610
 Email reception@carrera-toys.com
 Internet www.carrera-rc.com

BENELUX
Stadlbauer Marketing + Vertrieb GmbH
 Landsheerlaan 33
 6114 MP Susteren - Netherlands
 Email service.benelux@carrera-toys.com
 Internet www.carrera-rc.com

FRANCE
Stadlbauer Marketing + Vertrieb GmbH
 21 B. Route Nationale
 Domaine de L'Hancartrie
 59320 Ennetières-En-Weppes - France
 Phone +33 3 20384893
 Fax +33 3 20384893
 Email carrera-toys@orange.fr
 Internet www.carrera-rc.com

SPAIN / PORTUGAL / LATIN AMERICA
Stadlbauer Iberia SLU
 Calle Fluvia 92, 1º 2º
 08019 Barcelona - Spain
 Phone +34 93 3036335
 Email contacto@carrera-toys.com
 Internet www.carrera-rc.com

HUNGARY
Magyarország Importer
Stadlbauer Marketing + Vertrieb GmbH
 Rennbahn Allee 1
 5412 Puch / Salzburg - Austria
 Phone +36 305556 502
 Email office@stadlbauer-toys.hu
 Internet www.carrera-rc.com
Service:
GAME PARK - VINGZE ZOLTAN
 Borky Lili utca 38. - 1171 Budapest
 Hungary
 Phone +36 1 258-7809
 Email vingze@online.hu

ITALY
Stadlbauer Marketing + Vertrieb GmbH
 Rennbahn Allee 1
 5412 Puch / Salzburg - Austria
 Phone +39 0735 081094
 Email assistenza@carrera-toys.com
 Internet www.carrera-rc.com
Service:
 Model Assistance s.r.l.
 Via Guadiana 24
 42124 Reggio Emilia - Italy
 Phone +39 985 4275395
 Email assistenza@carrera@radiokontrol.it

POLAND
Stadlbauer Marketing + Vertrieb GmbH
 Rennbahn Allee 1
 5412 Puch / Salzburg - Austria
 Phone +48 515 056 296
 Mobile +48 71 393 78 10
 Email office@stadlbauer-toys.pl
 Internet www.carrera-rc.com
Service:
REKMAN B&B IT
 Ul. Europejska 4, Magnica
 55-040 Kobierzyc - Poland
 Phone +48 515 006 296
 Mobile +48 71 393 78 10
 Email serwis@carrera@rekman.com.pl

CARRERA DISTRIBUTORS

AUSTRALIA
Zimble Pty Ltd.
 899 Heidelberg Road
 Ivanhoe, Victoria 3079 - Australia
 Phone +61 3 94911000
 Fax +61 3 94972311
 Email sales@zimble.com.au
 Internet www.zimble.com.au

BULGARIA
Wentzhev Ltd.
 78a, Maria Luiza Blvd.
 1202 Sofia - Bulgaria
 Phone +359 283 22020
 Fax +359 283 22020
 Email kwanchev@wintel.bg

CHINA
Shanghai Wowgame
 Commercial Company Ltd.
 Room 110, Tower 1,
 Canton Centre
 88 Kayuan Road,
 (Zhengqiang Hi-Tech Park),
 Pudong,
 201203 Shanghai - China
 Phone +86 21 53821892
 Mobile +86 159 74149459
 Email eddyshaniwowgame.com.cn
 Internet www.wowgame.net.cn

CYPRUS
TOYS TOYS GAMES WORLD LTD
 38 Sappho Kyprianos Street
 4043 Potamos Germasogias,
 Limassol - Cyprus
 Phone +357 25 430043
 Email info@toytower.com
 Internet www.toytower.com

CZECH REPUBLIC
ConQuest entertainment a.s.
 Hloubetínska 11
 196 00 Praha 9 - Hloubetin
 Czech Republic
 Phone +420 284 000 111
 Fax +420 284 000 101
 Email radim.kaloc@conquest.cz
 Internet www.cqe.cz

DENMARK / SWEDEN / NORWAY / FINLAND / ICELAND
Tactic Games Oy
 Raumanjuventie 2
 P.O. Box 4444
 28101 Rani - Finland
 Phone +358 2 624 4144
 Fax +358 2 624 4211
 Email info@tactic.net
 Internet www.tactic.net

ESTONIA
Anvol Ltd.
 Madikse 7,
 74114 Maarju - Estonia
 Phone +372 63 88 100
 Fax +372 63 88 101
 Email anvol@anvol.eu
 Internet www.anvoleu

GREECE
Enarxis Dynamic Media Ltd.
 68 Iliakou Street
 11 744, Neos Kosmos
 Athens - Greece
 Phone +30 2109011900
 Fax +30 2109026700
 Email info@enarxis.eu
 Internet www.enarxis.eu

HONG KONG
Chun Lee (HK) Industrial Limited
 RM, 1801-5, 18/F.,
 King Palace Plaza,
 52A Sha Tsui Road,
 Tsuen Wan
 N.T. Hong Kong
 Phone +852 910 36679
 Email eddychan@yu-lee.com

INDONESIA
PT. Toys Games Indonesia
 Kawan Lama Building,
 7th Floor,
 Jl. Puri Kencana No. 1
 Melayu - Kembangan
 Jakarta 11610 - Indonesia
 Phone +62 21 58290-06
 Fax +62 21 58290-16
 Email smile@toyskingdom.co.id
 Internet www.toyskingdom.co.id

ISRAEL
TOP PLAY ISRAEL (TPI) LTD
 P.O. Box 7823 Kiryat Matlan
 Petach-Tikva
 48250 - Israel
 Phone +972 3 9323767
 Mobile +972 52 6338966
 Fax +972 3 9086074
 Email top-play@t12.net.il
 Internet www.TopPlay-toys.com

LEBANON
F. AOUAD
 P.O. Box 1565 Jounieh Lebanon
 Twin Towers Building Blk A
 Sarra High Way
 Jounieh - Lebanon
 Phone +961 3 840505
 Fax +961 9 635473
 Email niel.aouad@faouad.com

MONGOLIA
Circle LLC
 Encanto Town
 District Bayanzurkh 26th khoroo
 Kh Mongol State Street
 210623 Ulaanbaatar - Mongolia
 Phone +976 77073034
 Fax +976 11 305648
 Email import1@orgil.mn
 Internet www.orgil.mn

NEW ZEALAND
FW Cave Ltd.
 15 Old North Road
 P.O. Box 276,
 Kumeu 0611
 Auckland - New Zealand
 Phone +64 9 4157 766
 Fax +64 9 4157 099
 Email sales@fwcave.co.nz
 Internet www.fwcave.co.nz

RUSSIA
Unitoys MSK Ltd.
 Mnavniki, 7-2
 123308 Moscow - Russia
 Phone +7 495 278 0266
 Fax +7 499 946 4616
 Email office@unitoys.ru
 Internet www.unitoys.ru

SERBIA / MONTENEGRO
CoolPlay d.o.o.
 Dr. Nika Miljanica 1B
 11000 Baigrada - Serbia
 Phone +381 65 8026620
 Email office@coolplay.rs

SWITZERLAND
Waldmeier AG
 Neustrasse 50
 4663 Neuendorf - Switzerland
 Phone +41 62 387 98 18
 Fax +41 62 387 98 20
 Email info@waldmeier.ch
 Internet www.waldmeier.ch

TURKEY
SUNMAN SAN. MAM. ITH. IHR. ve TIC. A.Ş.
 Turgut Ozal Cad. No125
 41420 Cayirova / Kocaeli - Turkey
 Phone +90 216 499 80 80
 Fax +90 216 314 67 20
 Email info@sunman.com.tr
 Internet www.sunman.com.tr

UNITED KINGDOM
The Hobby Company Ltd.
 Garforth Place, Knowlhill
 Milton Keynes MK5 3PG - UK
 Phone +44 1908 205460
 Fax +44 1908 205900
 Email enquiries@hobbyco.net
 Internet www.hobbyco.net

UNITED ARAB EMIRATES
Toyworld Distributor
 P.O. Box 289, Gibca Building
 Al Wahda Street, Sharjah - UAE
 Phone +971 6 5337418
 Fax +971 6 5336682
 Email info@toyworlduae.com
 Internet www.toyworlduae.com

VIETNAM
Viet Tinh Anh JSC
 163-38 Street D4, Him Lam,
 Tan Hung ward,
 Dist.7, Ho Chi Minh City - Vietnam
 Phone +84 8 543187-17
 Fax +84 8 543187-16
 Email info@viettinhanh.com.vn
 Internet www.viettinhanh.com.vn



CARRERA-RC.COM

Stadlbauer Marketing + Vertrieb GmbH · Rennbahn Allee 1 · 5412 Puch / Salzburg · Austria