



Installation, Start-Up and Service Instructions

CONTENTS

| | Page |
|--|------------|
| SAFETY CONSIDERATIONS | 1 |
| INSTALLATION | 1-37 |
| Step 1 — Rig and Place Unit | 1 |
| • DOMESTIC UNITS | |
| • EXPORT UNITS | |
| • PLACING UNITS | |
| Step 2 — Check Compressor Mounting | 3 |
| • UNITS 38AH044-084 | |
| • UNITS 38AH094-134 | |
| Step 3 — Make Refrigerant Piping Connections | 14 |
| • UNITS 38AH044-084 | |
| • UNITS 38AH094-134 | |
| Step 4 — Make Electrical Connections | 23 |
| • POWER SUPPLY | |
| • FIELD POWER CONNECTIONS | |
| • MAIN POWER | |
| • CONTROL CIRCUIT WIRING | |
| Step 5 — Install Accessories | 37 |
| • LOW-AMBIENT OPERATION | |
| • MISCELLANEOUS ACCESSORIES | |
| PRE-START-UP | 37,38 |
| START-UP | 38-45 |
| SERVICE | 46-49 |
| CONTROL | 49-52 |
| TROUBLESHOOTING | 53,54 |
| START-UP CHECKLIST | CL-1, CL-2 |

SAFETY CONSIDERATIONS

Installing, starting up, and servicing this equipment can be hazardous due to system pressures, electrical components, and equipment location (roofs, elevated structures, etc.).

Only trained, qualified installers and service mechanics should install, start up, and service this equipment.

Untrained personnel can perform basic maintenance functions, such as cleaning coils. All other operations should be performed by trained service personnel.

When working on the equipment, observe precautions in the literature, and on tags, stickers, and labels attached to the equipment and any other safety precautions that may apply.

- Follow all safety codes.
- Wear safety glasses and work gloves.
- Use care in handling, rigging, and setting bulky equipment.



ELECTRIC SHOCK HAZARD.
Open all remote disconnects before servicing this equipment.

INSTALLATION

Step 1 — Rig and Place Unit — All units are designed for overhead rigging, and *it is important that this method be used*. Lifting holes are provided in the frame base rails, which are marked for rigging (see rigging label on the unit and Tables 1, 2A, and 2B for rigging weights and center of gravity). It is recommended that field-supplied pipes, of sufficient length to extend at least 12-in. (305 mm) beyond the frame, be passed through the holes.

To maintain unit stability while lifting, use 4 cables, chains, or straps of equal length. Attach one end of each cable to one pipe end and the other end of each cable to the overhead rigging point.

Use spreader bars or frame to keep the cables, chains, and straps clear of the unit sides. Leave standard coil protection packaging in place during rigging to provide protection to coils. Remove and discard all coil protection after rigging cables are detached.

DOMESTIC UNITS — For units 38AH044-084, 124, and 134; standard unit packaging consists of coil protection only. There is no standard packaging provided for units 38AH094 and 104. *Skids are not provided.* If overhead rigging is not available at the jobsite, place the unit on a skid or pad before dragging or rolling. When rolling, use a minimum of 3 rollers. When dragging, pull the pad or skid. *Do not apply force to the unit.* When in final position, raise from above to lift unit off the pad or skid.

EXPORT UNITS — All export units are mounted on skids with vertical coil protection. Leave the unit on the skid until it is in final position. *While on the skid, the unit can be rolled or skidded. Apply force to the skid, not to the unit.* Use a minimum of 3 rollers when rolling. When in final position, raise from above to remove the skid.

PLACING UNITS

Units 38AH044-084 — Refer to Fig. 1 and 2 for airflow clearances. Recommended minimum clearances are 6 ft (1829 mm) for unrestricted airflow and service on sides of unit, 5 ft (1524 mm) on ends, and unrestricted clear air space above the unit. Provide ample space to connect liquid and suction lines to indoor unit. For multiple units, allow 8 ft (2440 mm) separation between units for airflow and service.

⚠ CAUTION

Do not forklift these units unless the unit is attached to a skid designed for forklifting.

The placement area must be level and strong enough to support the operating weight of the unit (see Table 3A or 3B). When unit is in proper location, use of mounting holes in base rails is recommended for securing unit to supporting structure. For mounting unit on vibration isolators, a perimeter support channel between the unit and the isolators is recommended. Fasteners for mounting unit are field supplied. Be sure to mount unit level to ensure proper oil return to compressors.

Units 38AH094-134 — Refer to Fig. 3-6 for airflow clearances. Recommended minimum clearances are 6 ft (1829 mm) for unrestricted airflow and service on sides of unit, 5 ft (1524 mm) on ends, and unrestricted clear air space above unit. Provide ample space to connect liquid and suction lines to indoor unit. For multiple units, allow 8 ft (2440 mm) separation between units for airflow and service.

⚠ CAUTION

Do not forklift these units unless the unit is attached to a skid designed for forklifting.

The placement area must be level and strong enough to support the operating weight of the unit. See Table 4A or 4B. Refer to the following paragraphs for the proper placement of the unit.

Units 38AH094,104 — For mounting units on vibration isolators, a perimeter support channel is required between the unit and the support isolators. The perimeter support channel must be sized to support the fully assembled unit. Do not

support units on individual isolation supports. Support channel, hardware, and fasteners are field supplied. When unit is in proper location, level unit and bolt into position with field-supplied bolts.

Units 38AH124,134 — For ease of shipment and handling, unit 38AH124 is shipped as 2 modules (124A and 124B) and unit 38AH134 is shipped as 2 modules (134A and 134B). The modules must be connected at the final installation site with the factory-shipped piping and sheet metal trim kit mounted on Module 124A or 134A. See Fig. 7.

⚠ WARNING

Do not move assembled 38AH124 or 134 units as a single assembly. Always move modules individually during installation or at any other time.

Mark installation site for placement of Modules 124A and 124B or Modules 134A and 134B. See Table 4A or 4B for final assembled dimensions. A service space of 24 in. (610 mm) is required between the 2 modules for piping and sheet metal trim installation.

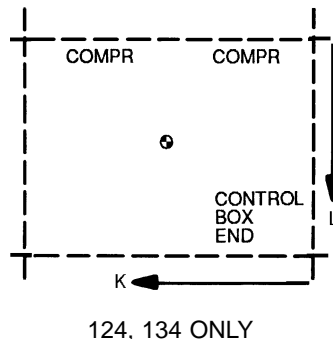
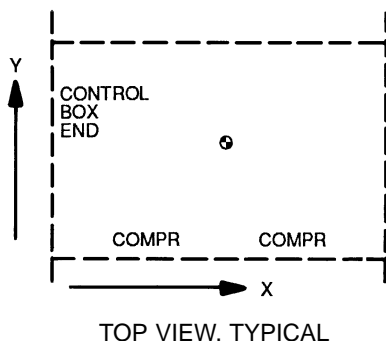
Place Module 124A or 134A in position, ensuring that the control box is at the end opposite the service space. See Fig. 8.

Remove sheet metal and tubing from Module 124A or 134A sheet metal trim kit (Fig. 7). Remove sheet metal cover panels from return-bend end of unit facing the service space. See Fig. 8. These panels may be discarded or saved for reinstallation if module is moved from site. See Fig. 9.

Table 1 — Rigging Center of Gravity — in. (mm)

| UNIT 38AH | 044 | 054 | 064 | 074 | 084 | 094 | 104 | MODULE 124A | MODULE 124B | MODULE 134A | MODULE 134B |
|---------------|-----------|-----------|-----------|-----------|-----------|-----------|-----------|----------------|----------------|----------------|----------------|
| Dimension X | 49 (1232) | 48 (1224) | 50 (1260) | 57 (1443) | 57 (1448) | 66 (1676) | 63 (1600) | 50 (1260) | — | 50 (1260) | — |
| Dimension Y | 39 (984) | 39 (978) | 38 (968) | 39 (993) | 39 (991) | 31 (787) | 34 (851) | 38 (968) | — | 38 (968) | — |
| Dimension X-C | 49 (1234) | 48 (1229) | 50 (1261) | 56 (1425) | 56 (1422) | 66 (1676) | 63 (1600) | 50 (1260) | — | 50 (1260) | — |
| Dimension Y-C | 39 (993) | 39 (991) | 39 (986) | 40 (1006) | 40 (1008) | 31 (787) | 34 (851) | 39 (986) | — | 39 (986) | — |
| Dimension K | — | — | — | — | — | — | — | — | 50 (1260) | — | 57 (1443) |
| Dimension L | — | — | — | — | — | — | — | — | 38 (968) | — | 39 (993) |
| Dimension K-C | — | — | — | — | — | — | — | — | 50 (1260) | — | 56 (1425) |
| Dimension L-C | — | — | — | — | — | — | — | — | 39 (986) | — | 40 (1006) |

LEGEND
 — — Not Applicable
 C — Copper Fin Coils



Remove sheet metal cover panels from return-bend end of Module 124B or 134B. Place Module 124B or 134B in position. The exposed return-bend ends of each module are now opposite each other and facing the service space. The compressors of each module are on opposite sides of the unit.

IMPORTANT: Modules must be placed 24 in. (610 mm) apart and square relative to each other.

The modules are now in position for piping installation and final assembly. See Fig. 8. For mounting units on vibration isolators, a perimeter support channel is required between the assembled unit and the support isolators. The perimeter support channel must be sized to support the fully assembled unit. Do not support modules on individual isolation supports. Support channel, hardware, and fasteners are field supplied.

When unit is in proper location, level unit and bolt into position with field-supplied bolts.

Table 2A — Operational Corner Weights with Refrigerant Charge (Approximate) — Lb

| UNIT 38AH | TOTAL WEIGHT | OPERATIONAL CORNER WEIGHT | | | |
|------------------------|-----------------|---------------------------|------|------|------|
| | | A | B | C | D |
| 044 | 3259 | 939 | 893 | 695 | 732 |
| 044C | 3547 | 1013 | 967 | 765 | 802 |
| 054 | 3309 | 964 | 905 | 697 | 742 |
| 054C | 3597 | 1034 | 978 | 771 | 814 |
| 064 | 3565 | 1018 | 1011 | 765 | 771 |
| 064C | 3998 | 1125 | 1117 | 874 | 879 |
| 074 | 3812 | 1146 | 986 | 777 | 903 |
| 074C | 4229 | 1272 | 1059 | 862 | 1035 |
| 084 | 4057 | 1220 | 1049 | 827 | 961 |
| 084C | 4735 | 1425 | 1186 | 965 | 1159 |
| 094 | 5088 | 1114 | 2192 | 1182 | 601 |
| 094C | 5813 | 1273 | 2504 | 1350 | 686 |
| 104 | 5435 | 1240 | 2138 | 1302 | 755 |
| 104C | 6160 | 1405 | 2423 | 1476 | 856 |
| MODULE 38AH | | | | | |
| 124A | 3630 | 1037 | 1030 | 779 | 785 |
| 124A-C | 4063 | 1144 | 1137 | 889 | 894 |
| 124B | 3630 | 1037 | 1030 | 779 | 785 |
| 124B-C | 4063 | 1144 | 1137 | 889 | 894 |
| 134A | 3630 | 1037 | 1030 | 779 | 785 |
| 134A-C | 4063 | 1144 | 1137 | 889 | 894 |
| 134B | 3877 | 1167 | 997 | 789 | 924 |
| 134B-C | 4294 | 1293 | 1080 | 874 | 1047 |

LEGEND

C — Copper Fin Coils

NOTE: Total weight may differ from summation of corner weights due to rounding of numerals.

Step 2 — Check Compressor Mounting

UNITS 38AH044-084 — Compressors are mounted on pans and are held down by 4 bolts during shipment. After unit is installed, loosen each of these bolts until the snubber washer can be moved with finger pressure. See Fig. 10.

UNITS 38AH094-134 — Units 38AH094 and 104 compressors are mounted on rails and held down by rail bolts during shipment. After unit is installed, loosen the rail bolts to allow the rails and compressors to float freely on the springs located under the rails. See Fig. 10.

Units 38AH124 and 134 compressors are mounted on pans and are held down by 4 bolts during shipment. After unit is installed, loosen each of these bolts until snubber washer can be moved with finger pressure. See Fig. 10.

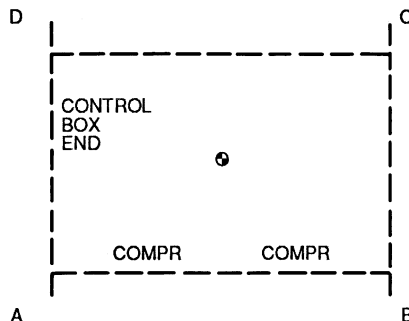
Table 2B — Operational Corner Weights with Refrigerant Charge (Approximate) — Kg

| UNIT 38AH | TOTAL WEIGHT | OPERATIONAL CORNER WEIGHT | | | |
|------------------------|-----------------|---------------------------|------|-----|-----|
| | | A | B | C | D |
| 044 | 1478 | 426 | 405 | 316 | 332 |
| 044C | 1609 | 460 | 438 | 347 | 364 |
| 054 | 1501 | 437 | 411 | 316 | 337 |
| 054C | 1632 | 469 | 444 | 350 | 369 |
| 064 | 1617 | 462 | 459 | 347 | 350 |
| 064C | 1813 | 510 | 508 | 397 | 399 |
| 074 | 1729 | 520 | 447 | 352 | 410 |
| 074C | 1918 | 577 | 481 | 391 | 470 |
| 084 | 1840 | 553 | 476 | 375 | 436 |
| 084C | 2148 | 646 | 538 | 438 | 526 |
| 094 | 2308 | 505 | 994 | 536 | 272 |
| 094C | 2637 | 577 | 1136 | 612 | 311 |
| 104 | 2465 | 562 | 970 | 591 | 342 |
| 104C | 2794 | 637 | 1099 | 670 | 388 |
| MODULE 38AH | | | | | |
| 124A | 1647 | 470 | 467 | 353 | 356 |
| 124A-C | 1843 | 519 | 516 | 403 | 405 |
| 124B | 1647 | 470 | 467 | 353 | 356 |
| 124B-C | 1843 | 519 | 516 | 403 | 405 |
| 134A | 1647 | 470 | 467 | 353 | 356 |
| 134A-C | 1843 | 519 | 516 | 403 | 405 |
| 134B | 1759 | 529 | 452 | 358 | 419 |
| 134B-C | 1948 | 587 | 490 | 396 | 475 |

LEGEND

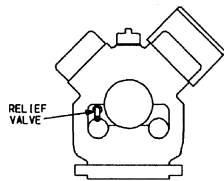
C — Copper Fin Coils

NOTE: Total weight may differ from summation of corner weights due to rounding of numerals.



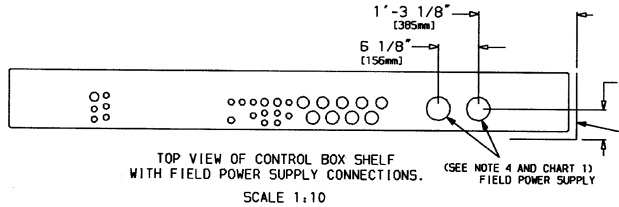
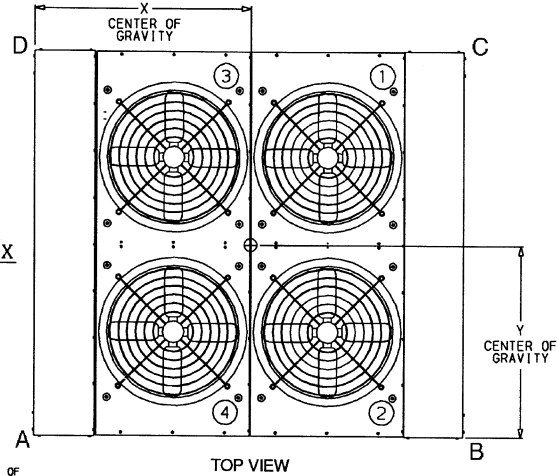
TOP VIEW, TYPICAL

| | DUAL CKT | SINGLE CKT |
|-----------------------|-----------------|-----------------|
| SUCTION CONNECTION(S) | 2½" Dia [64 mm] | 2¾" Dia [67 mm] |
| LIQUID CONNECTION(S) | ¾" Dia [22 mm] | 1½" Dia [29 mm] |
| SUCTION C | 2'-11½" [627mm] | 1'-10¾" [567mm] |
| LIQUID D | 1'-10¼" [561mm] | 1'-10¾" [567mm] |
| SUCTION (Ckt A) | 1'-7¾" [503mm] | 2'-5½" [626mm] |
| SUCTION (Ckt B) | 2'-9" [626mm] | — |
| LIQUID (Ckt A) | 2'-5¼" [756mm] | 2'-10¾" [879mm] |
| LIQUID (Ckt B) | 2'-10¾" [879mm] | — |

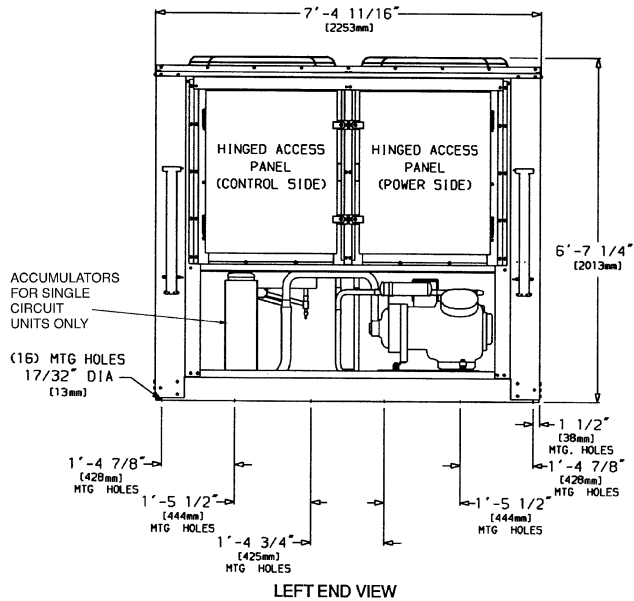


RELIEF VALVES LOCATED ON THE COMPRESSORS ARE EQUIPPED WITH A 3/8" SAE FLARE FOR FIELD CONNECTION
SCALE 1:8

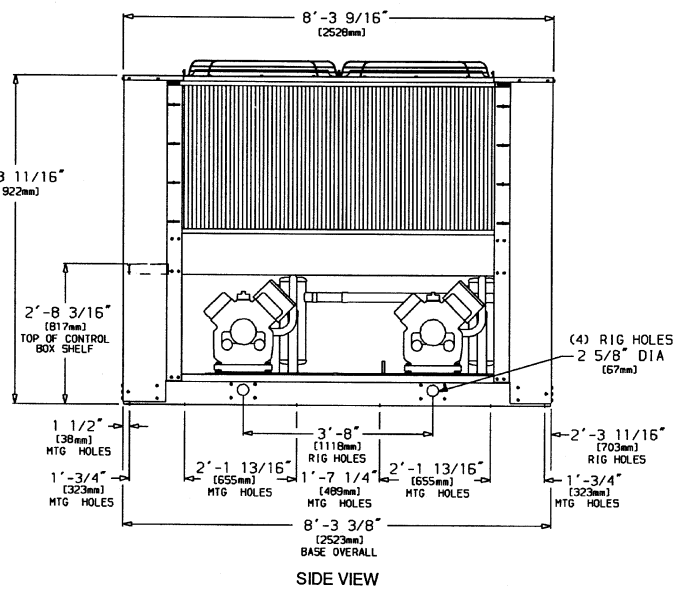
CONTROL BOX END



TOP VIEW OF CONTROL BOX SHELF WITH FIELD POWER SUPPLY CONNECTIONS.
SCALE 1:10



LEFT END VIEW



SIDE VIEW

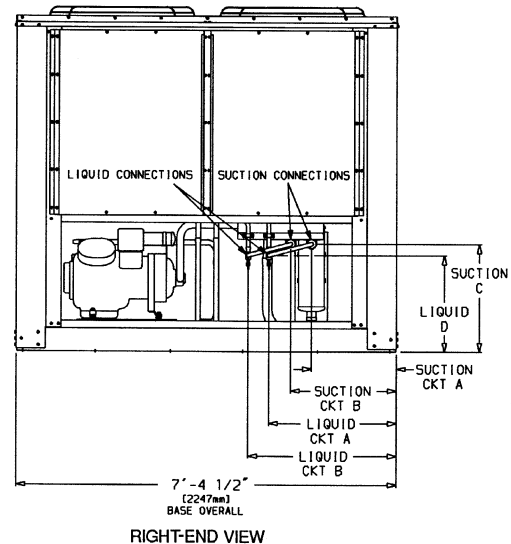
Chart 1, Field Power Supply Connections

| UNIT | VOLTAGE | Hz | DIAMETER — in. [mm] | QTY |
|---------------|--------------|----|---------------------|-----|
| 044 | 230 | 50 | 3¾ [92] | 1 |
| 044, 054 | 208/230 | 60 | 3¾ [92] | 1 |
| | 346, 380/415 | 50 | 2½ [63] | 1 |
| 044, 054, 064 | 460,575,380 | 60 | 2½ [63] | 1 |
| | 208/230 | 60 | 2½ [63] | 2 |
| 064 | 346, 380/415 | 50 | 3¾ [92] | 1 |

LEGEND
C — Copper Fin Coils
MTG — Mounting
SAE — Society of Automotive Engineers

NOTES:

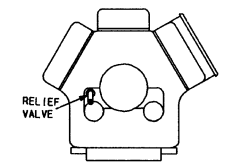
- The approximate operating weight of the unit is:
 38AH-044--- 3259 lb [1478 kg]
 38AH-044--C 3547 lb [1609 kg]
 38AH-054--- 3309 lb [1501 kg]
 38AH-054--C 3597 lb [1632 kg]
 38AH-064--- 3565 lb [1617 kg]
 38AH-064--C 3998 lb [1813 kg]
- Unit must have clearances for airflow as follows:
 Top — Do not restrict in any way.
 Ends — 5 ft [1524 mm]
 Sides — 6 ft [1829 mm]
- Mounting holes may be used to mount unit to concrete pad. They are not recommended for mounting unit to spring isolators. If spring isolators are used, a perimeter support channel between the unit and the isolators is recommended.
- One 3¾" (92 mm) diameter hole is recommended for single-entry power on size 064 (208/230-v) units.
- See Table 1 for rigging center of gravity (Dimensions X,Y). See Table 2A and 2B for A-D corner weights.
- Circled numerals in Top View refer to condenser fans by position.



RIGHT-END VIEW

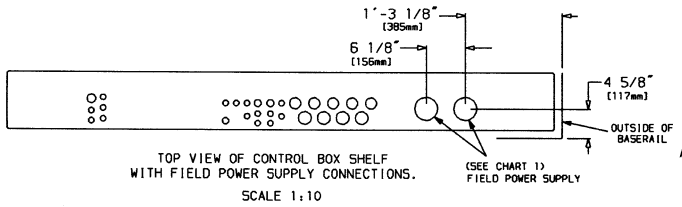
Fig. 1 — Dimensions — Units 38AH044,054,064

| | DUAL CKT | SINGLE CKT |
|-----------------------|-----------------|-----------------|
| SUCTION CONNECTION(S) | 2½" Dia [64 mm] | 2⅝" Dia [67 mm] |
| LIQUID CONNECTION(S) | ⅞" Dia [22 mm] | 1⅛" Dia [29 mm] |
| SUCTION C | 2'-11½" [627mm] | 1'-10⅝" [567mm] |
| LIQUID D | 1'-10⅛" [561mm] | 1'-10⅝" [567mm] |
| SUCTION (Ckt A) | 1'-7⅜" [503mm] | 2'-5⅞" [626mm] |
| SUCTION (Ckt B) | 2'-5⅞" [626mm] | — |
| LIQUID (Ckt A) | 2'-5¾" [756mm] | 2'-10⅞" [879mm] |
| LIQUID (Ckt B) | 2'-10⅞" [879mm] | — |

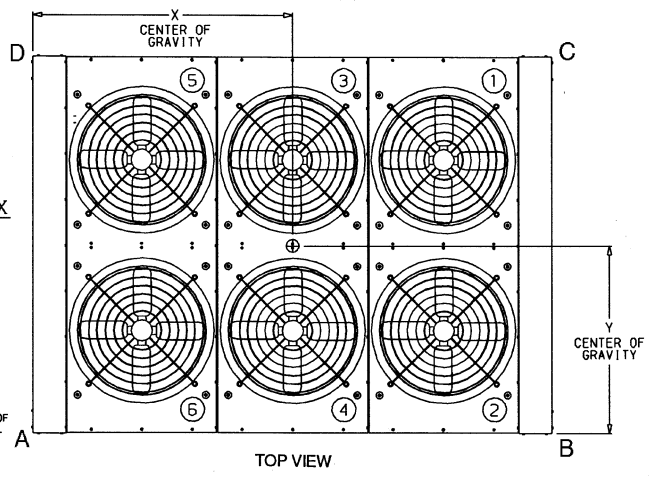


RELIEF VALVES LOCATED ON THE COMPRESSORS ARE EQUIPPED WITH A 3/8" SAE FLARE FOR FIELD CONNECTION
SCALE 1:8

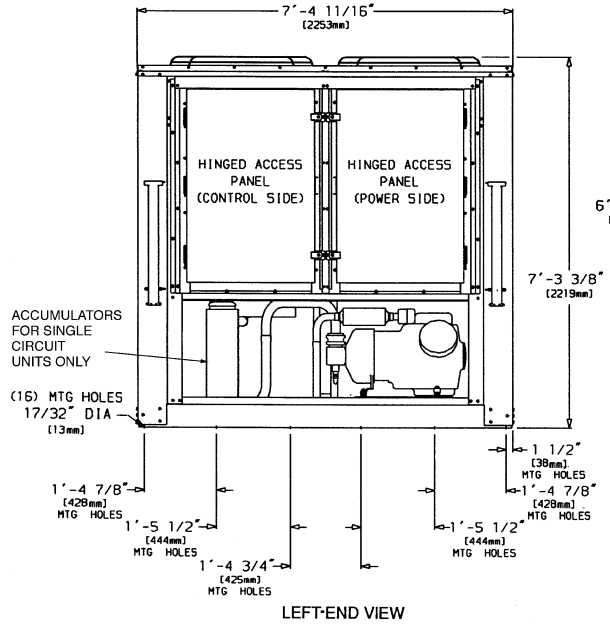
CONTROL BOX
END



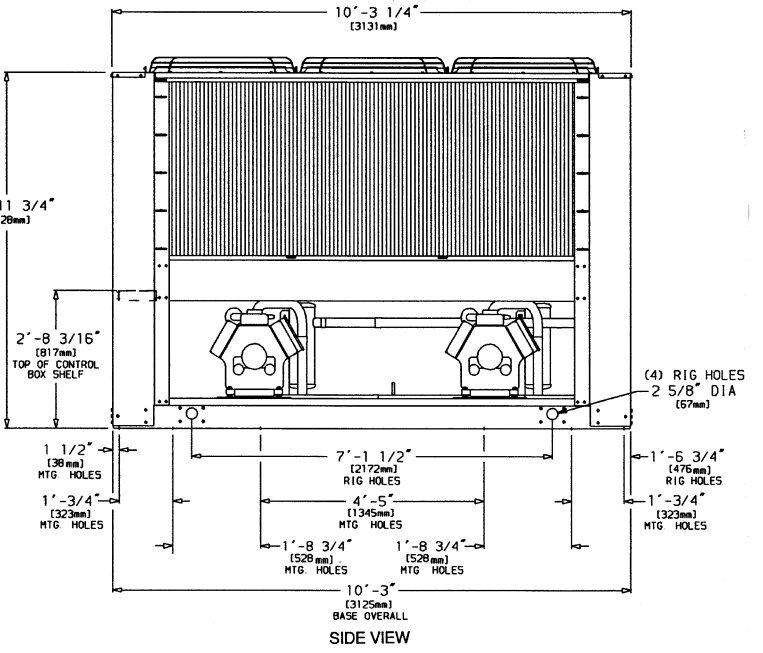
TOP VIEW OF CONTROL BOX SHELF WITH FIELD POWER SUPPLY CONNECTIONS.
SCALE 1:10



TOP VIEW



LEFT-END VIEW



SIDE VIEW

Chart 1, Field Power Supply Connections

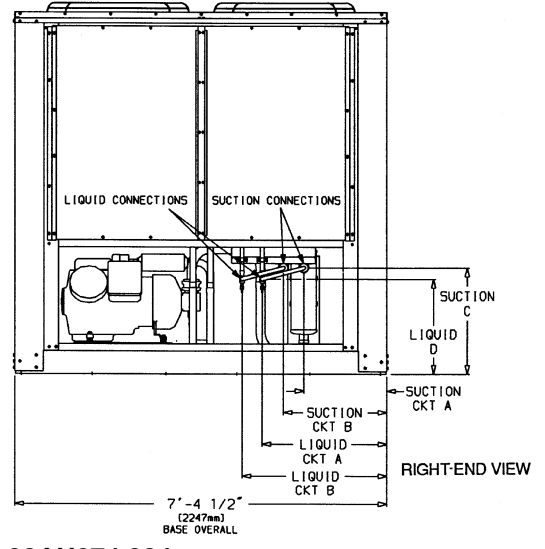
| UNIT | VOLTAGE | Hz | DIAMETER — in. [mm] | QTY |
|----------|--------------|----|---------------------|-----|
| 074 | 208/230 | 60 | 2½ [63] | 2 |
| | 460 | 60 | 2½ [63] | 1 |
| 074, 084 | 346, 380/415 | 50 | 3% [92] | 1 |
| | 380 | 60 | 3% [92] | 1 |
| 084 | 575 | 60 | 2½ [63] | 1 |
| | 208/230 | 60 | 3% [92] | 2 |
| | 460 | 60 | 3% [92] | 1 |

LEGEND

- C — Copper Fin Coils
- MTG — Mounting
- SAE — Society of Automotive Engineers

NOTES:

1. The approximate operating weight of the unit is:
38AH-074— 3812 lb (1729 kg)
38AH-074-C 4229 lb (1918 kg)
38AH-084— 4057 lb (1840 kg)
38AH-084-C 4735 lb (2148 kg)
2. Unit must have clearances for airflow as follows:
Top — Do not restrict in any way.
Ends — 5 ft [1524 mm]
Sides — 6 ft [1829 mm]
3. Mounting holes may be used to mount unit to concrete pad. They are not recommended for mounting unit to spring isolators. If spring isolators are used, a perimeter support channel between the unit and the isolators is recommended.
4. See Table 1 for rigging center of gravity (Dimensions X,Y). See Table 2A and 2B for A-D corner weights.
5. Circled numerals in Top View refer to condenser fans by position.



RIGHT-END VIEW

Fig. 2 — Dimensions — Units 38AH074,084

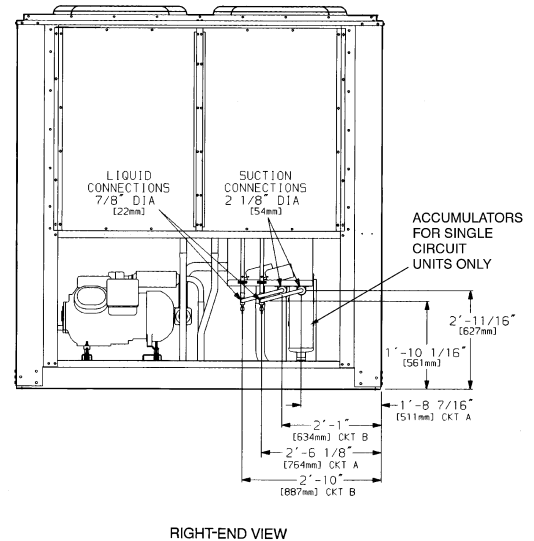
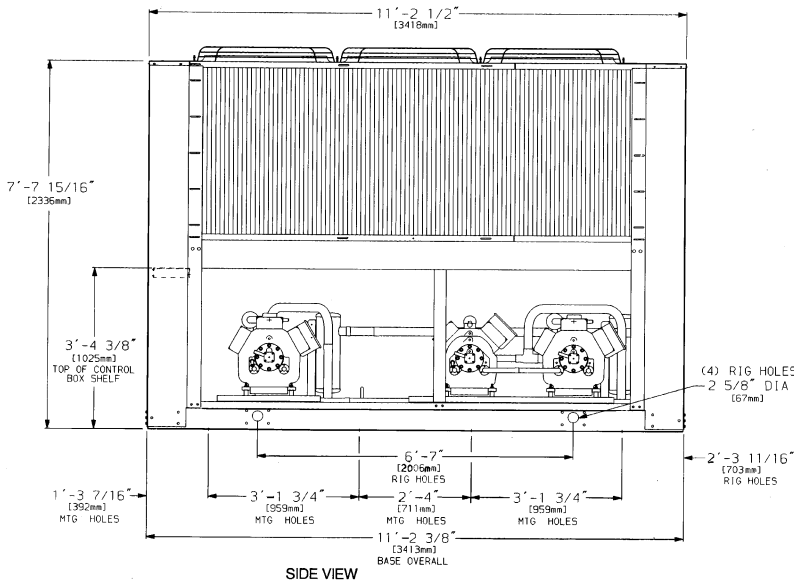
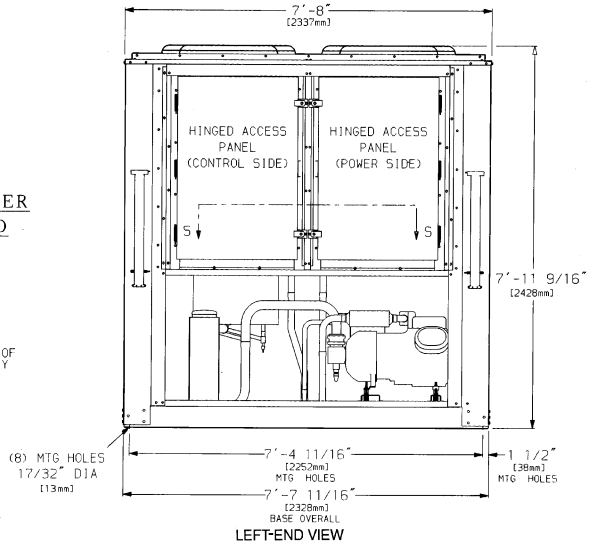
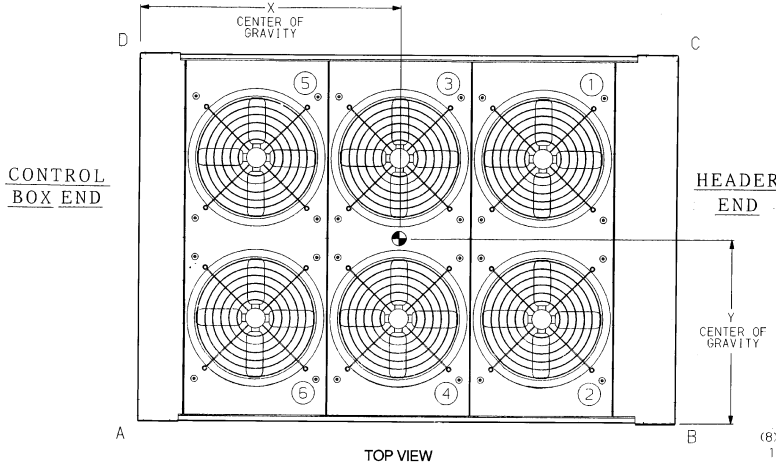
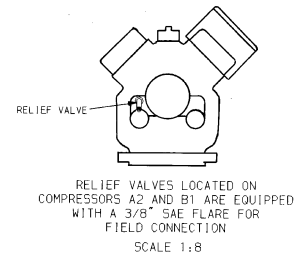
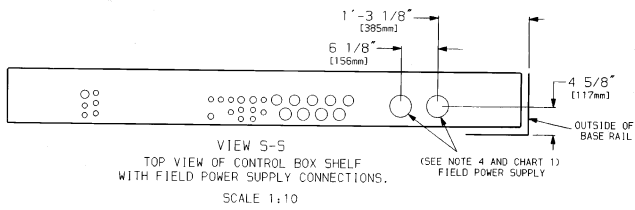


Chart 1, Field Power Supply Connections

| UNIT 38AH | VOLTAGE | Hz | DIAMETER — in. (mm) | QUANTITY |
|-----------|---------------|----|----------------------|----------|
| | 208/230 | 60 | 3 $\frac{5}{8}$ (92) | 2 |
| 094 | 460, 575, 380 | 60 | 3 $\frac{5}{8}$ (92) | 1 |
| | 346, 380/415 | 50 | 3 $\frac{5}{8}$ (92) | 1 |

LEGEND

- C — Copper Fin Coils
- MTG — Mounting
- SAE — Society of Automotive Engineers

NOTES:

1. The approximate operating weight of the unit is:
 38AH-094--- 5088 lb (2308 kg)
 38AH-094--C 5813 lb (2637 kg)
2. Unit must have clearances for airflow as follows:
 Top — Do not restrict in any way.
 Ends — 5 ft [1524 mm]
 Sides — 6 ft [1829 mm]
3. Mounting holes may be used to mount unit to concrete pad. They are not recommended for mounting unit to spring isolators.
4. Two 3 $\frac{5}{8}$ " (92-mm) dia holes are recommended for parallel conductors on 208/230 v units.
5. Circled numerals in Top View refer to condenser fans by position.
6. If spring isolators are used, a perimeter support channel between the unit and the isolators is recommended.
7. See Table 1 for rigging center of gravity (Dimensions X,Y). See Table 2A and 2B for A-D corner weights.

Fig. 3 — Dimensions — Unit 38AH094

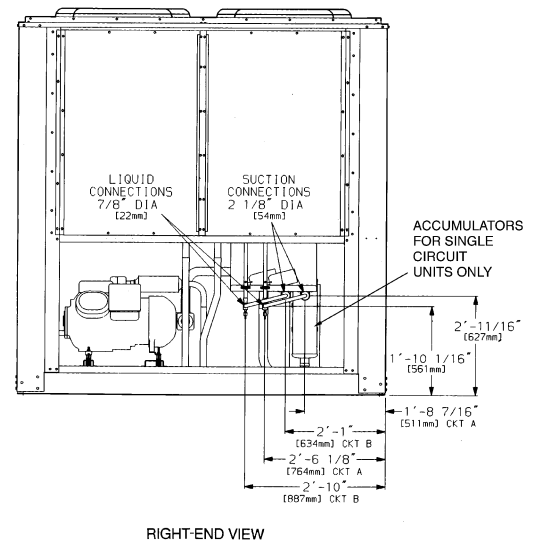
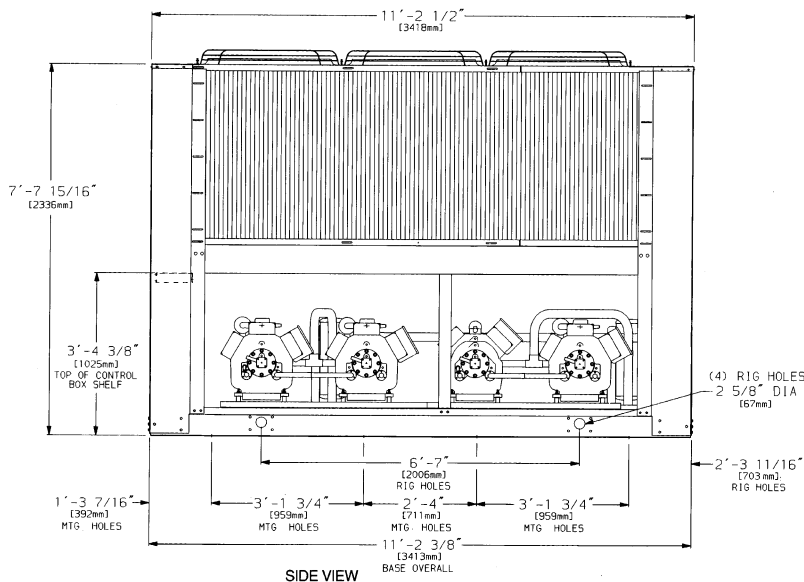
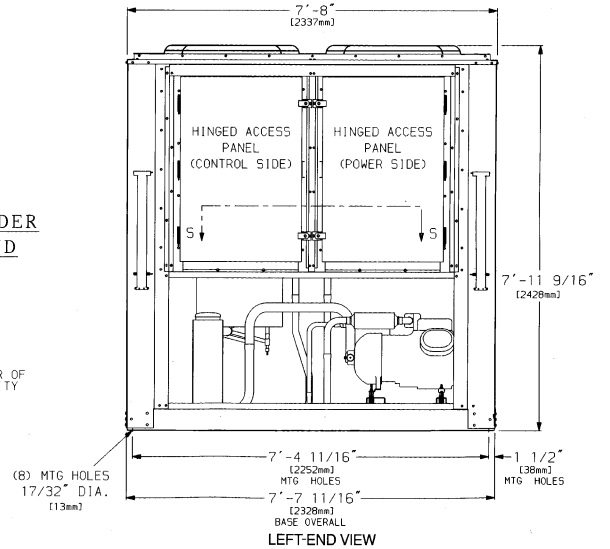
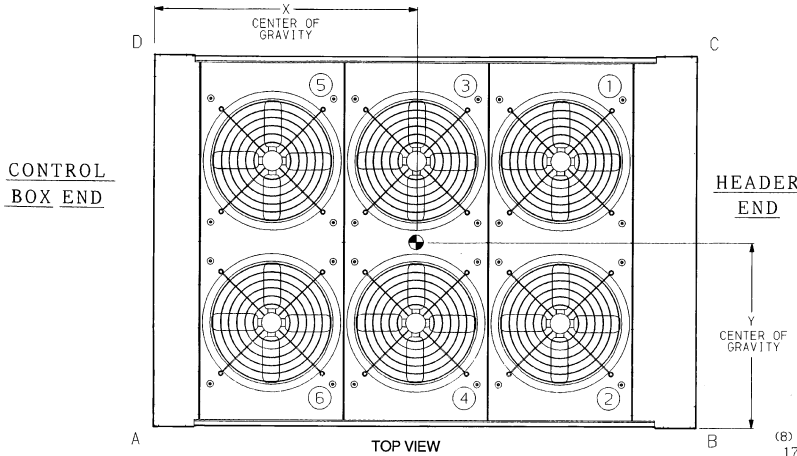
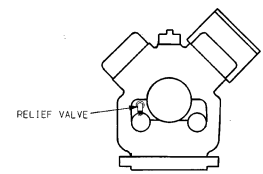
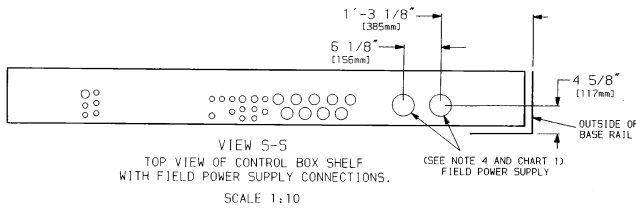


Chart 1, Field Power Supply Connections

| UNIT 38AH | VOLTAGE | Hz | DIAMETER — in. (mm) | QUANTITY |
|--------------|------------------|----|---------------------|----------|
| | 208/230 | 60 | 3/8 (92) | 2 |
| 104 | 460, 575, 380 | 60 | 3/8 (92) | 1 |
| | 346, 380/415 | 50 | 3/8 (92) | 1 |

LEGEND

- C — Copper Fin Coils
- MTG — Mounting
- SAE — Society of Automotive Engineers

NOTES:

1. The approximate operating weight of the unit is:
38AH-104--- 5435 lb (2465 kg)
38AH-104--C 6160 lb (2794 kg)
2. Unit must have clearances for airflow as follows:
Top — Do not restrict in any way.
Ends — 5 ft [1524 mm]
Sides — 6 ft [1829 mm]
3. Mounting holes may be used to mount unit to concrete pad. They are not recommended for mounting unit to spring isolators.
4. Two 3/8" (92-mm) dia holes are recommended for parallel conductors on 208/230 v units.
5. Circled numerals in Top View refer to condenser fans by position.
6. If spring isolators are used, a perimeter support channel between the unit and the isolators is recommended.
7. See Table 1 for rigging center of gravity (Dimensions X,Y). See Table 2A and 2B for A-D corner weights.

Fig. 4 — Dimensions — Unit 38AH104

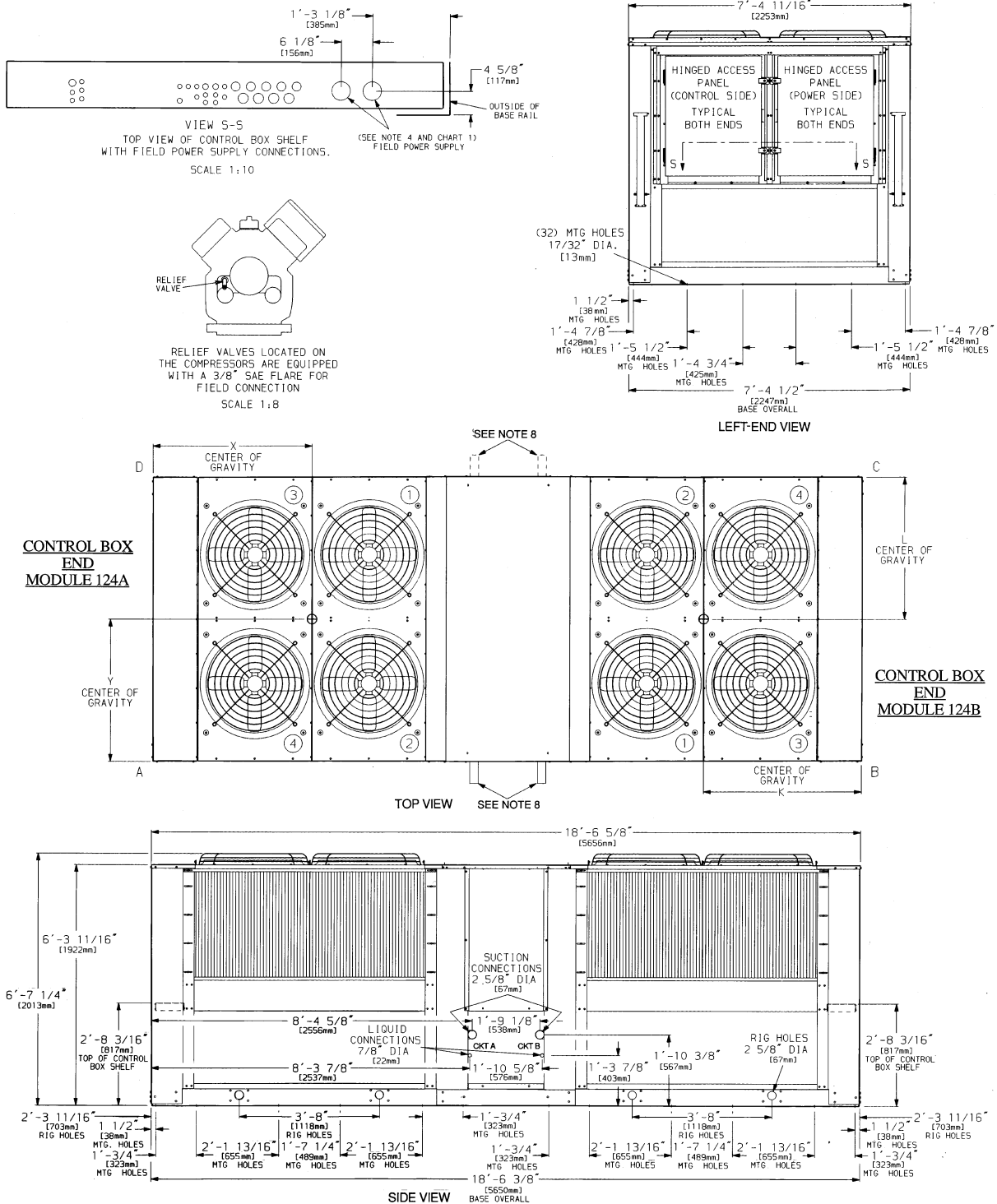


Chart 1, Field Power Supply Connections

| UNIT | VOLTAGE | HZ | DIAMETER (in.) | QUANTITY |
|------|---------------|----|----------------|----------|
| 38AH | 208/230 | 60 | 3 5/8 (92) | 1 |
| | 460, 575, 380 | 60 | 2 1/2 (63) | 1 |
| 124A | 346, 380/415 | 50 | 3 5/8 (92) | 1 |
| 124B | | | | |

LEGEND

- C** — Copper Fin Coils
- MTG** — Mounting
- SAE** — Society of Automotive Engineers

NOTES:

1. The approximate operating weight of the unit is:
38AH-124--- 7260 lb (3293 kg)
38AH-124--C 8126 lb (3686 kg)
2. Unit must have clearances for airflow as follows:
Top — Do not restrict in any way.
Ends — 5 ft [1524 mm]
Sides — 6 ft [1829 mm]
3. Mounting holes may be used to mount unit to concrete pad. They are not recommended for mounting unit to spring isolators.
4. One 3 5/8" (92-mm) dia hole is recommended for single-entry power into each module (124A and 124B) of the 208/230-v units.
5. Circled numerals in Top View refer to condenser fans by position.
6. If spring isolators are used, a perimeter support channel between the unit and the isolators is recommended. Do not support each module separately.
7. Each module of the unit must be rigged into position separately. The unit must not be rigged after modules have been connected.
8. Suction and liquid connections can exit on either side of the unit.
9. Field power supply connections are required for each module.
10. See Table 1 for rigging center of gravity (Dimensions K,L,X,Y). See Table 2A and 2B for A-D corner weights.

Fig. 5 — Dimensions — Unit 38AH124

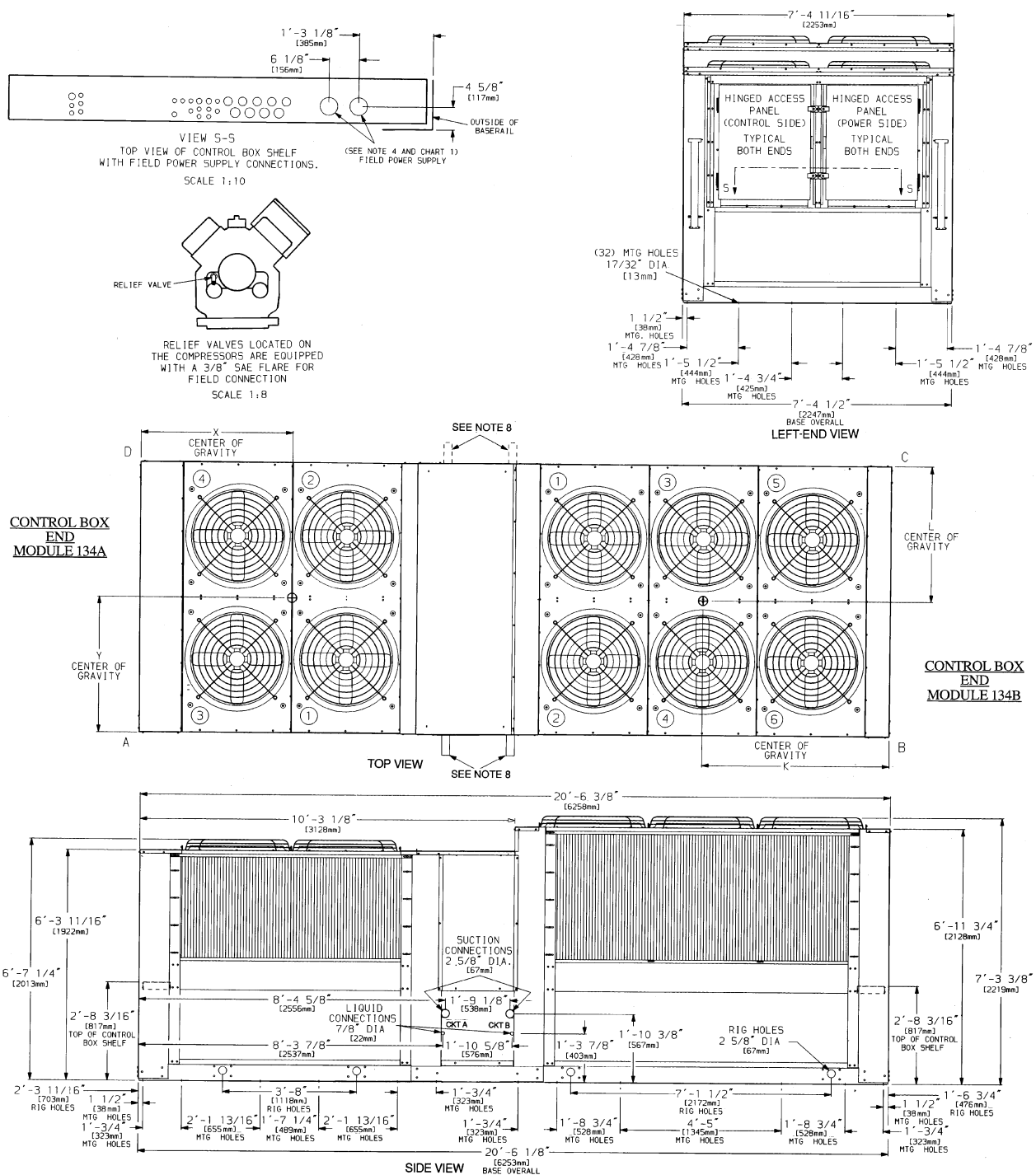


Chart 1, Field Power Supply Connections

| UNIT 38AH | VOLTAGE | Hz | DIAMETER — in. (mm) | QUANTITY |
|-----------|---------------|----|---------------------|----------|
| 134A | 208/230 | 60 | 3 5/8 (92) | 1 |
| | 460, 575, 380 | 60 | 2 1/2 (63) | 1 |
| | 346, 380/415 | 50 | 3 5/8 (92) | 1 |
| 134B | 208/230 | 60 | 2 1/2 (63) | 2 |
| | 460, 575 | 60 | 2 1/2 (63) | 1 |
| | 380 | 60 | 3 5/8 (92) | 1 |
| | 346, 380/415 | 50 | 3 5/8 (92) | 1 |

LEGEND

- C — Copper Fin Coils
- MTG — Mounting
- SAE — Society of Automotive Engineers

NOTES:

1. The approximate operating weight of the unit is:
38AH-134--- 7507 lb (3405 kg)
38AH-134--C 8357 lb (3791 kg)
2. Unit must have clearances for airflow as follows:
Top — Do not restrict in any way.
Ends — 5 ft [1524 mm]
Sides — 6 ft [1829 mm]
3. Mounting holes may be used to mount unit to concrete pad. They are not recommended for mounting unit to spring isolators.
4. One 3 5/8" (92-mm) dia hole is recommended for single-entry power into Module 134A and 208/230-v units. Single entry power into Module 134B is not recommended.
5. Circled numerals in Top View refer to condenser fans by position.
6. If spring isolators are used, a perimeter support channel between the assembled unit and the isolators is recommended. Do not support each module separately.
7. Each module of the unit must be rigged into position separately. The unit must not be rigged after modules have been connected.
8. Suction and liquid connections can exit on either side of the unit.
9. Field power supply connections are required for each module.
10. See Table 1A or 1B for rigging center of gravity (Dimensions K,L,X,Y). See Table 2A and 2B for A-D corner weights.

Fig. 6 — Dimensions — Unit 38AH134

Table 3A — Units 38AH044-084 Physical Data — 50/60 Hz (English)

| 38AH | | 044 | 054 | 064 | 074 | 084 | | | |
|--|----------------|--|--------------|--------------|---------------|---------------|--------|--------|--------|
| OPERATING WEIGHT WITH REFRIGERANT (Approx) — Lb | Cu-Al Cu-Cu | 3259 3547 | 3309 3597 | 3565 3998 | 3812 4229 | 4057 4735 | | | |
| SHIP WEIGHT WITH COIL PROTECTION ONLY (Approx) — Lb | Cu-Al Cu-Cu | 3250 3538 | 3290 3578 | 3530 3963 | 3780 4197 | 4000 4678 | | | |
| TYPICAL OPERATING REFRIGERANT CHARGE (Approx) — Lb | | R-22 | | | | | | | |
| Qty of Circuits | Std Opt | 62 2 1 | 72 2 1 | 88 2 1 | 104 2 1 | 130 2 1 | | | |
| COMPRESSOR Type...Rpm (Qty Cylinder) Compressor* Model No. 06E | Std | (4) A1 | (4) B1 | (4) A1 | (6) B1 | (6) A1 | (6) B1 | (6) A1 | (6) B1 |
| (Qty Cylinder) Compressor* Model No. 06E | Std | 250 | 250 | 250 | 265 | 265 | 275 | 275 | 299 |
| Oil Charge (Pt) | Opt | (4) A1 | (4) A2 | (6) A1 | (4) A2 | (6) A1 | (6) A2 | (6) A1 | (6) A2 |
| Capacity Control Steps† | Opt | 250 | 250 | 265 | 250 | 275 | 265 | 299 | 275 |
| | Std | 17 | 17 | 17 | 21 | 21 | 21 | 19 | 19 |
| | Opt | 17 | 17 | 21 | 17 | 21 | 21 | 19 | 19 |
| CONDENSER FANS (6 Blade) — 60 Hz | | Reciprocating Semi-Hermetic...1750 @ 60 Hz; 1458 @ 50 Hz | | | | | | | |
| Qty...Dia (in.) | | 4...30 | | | 6...30 | | | | |
| Airflow (Cfm) | | 35,000 | | | 52,000 | | | | |
| Speed (Rpm) | | 1140 | | | 1140 | | | | |
| Total Power (kW) | | 6.2 | | | 9.3 | | | | |
| CONDENSER FANS (6 Blade) — 50 Hz | | Enhanced Copper Tubes, Aluminum Lanced Fin | | | | | | | |
| Qty...Dia (in.) | | 4...30 | | | 6...30 | | | | |
| Airflow (Cfm) | | 35,000 | | | 52,000 | | | | |
| Speed (Rpm) | | 950 | | | 950 | | | | |
| Total Power (kW) | | 6.2 | | | 9.3 | | | | |
| CONDENSER COIL | | Enhanced Copper Tubes, Aluminum Lanced Fin | | | | | | | |
| Rows...Fins per in. | | 2...17 | 2...17 | 3...17 | 2...19 | 3...17 | | | |
| Face Area (sq ft) | | 80.5 | 80.5 | 80.5 | 116.7 | 116.7 | | | |
| Storage Capacity (Lb per Circuit) at 120 F | | 35 | 35 | 55 | 55 | 80 | | | |
| CONNECTIONS | | | | | | | | | |
| Suction, ODF (in.)** | | 2 1/8 | | | | | | | |
| Liquid, ODF (in.)** | | 7/8 | | | | | | | |
| Hot Gas Bypass, ODF (in.) | | 5/8 | | | | | | | |

Table 3B — Units 38AH044-084 Physical Data — 50/60 Hz (SI)

| 38AH | | 044 | 054 | 064 | 074 | 084 | | | |
|--|----------------|--|----------------|----------------|----------------|----------------|--------|--------|--------|
| OPERATING WEIGHT WITH REFRIGERANT (Approx) — Kg | Cu-Al Cu-Cu | 1478 1609 | 1501 1632 | 1617 1813 | 1729 1918 | 1840 2148 | | | |
| SHIP WEIGHT WITH COIL PROTECTION ONLY (Approx) — Kg | Cu-Al Cu-Cu | 1474 1605 | 1492 1623 | 1601 1798 | 1715 1904 | 1814 2122 | | | |
| TYPICAL OPERATING REFRIGERANT CHARGE (Approx) — Kg | | R-22 | | | | | | | |
| Qty of Circuits | Std Opt | 28.1 2 1 | 32.7 2 1 | 39.9 2 1 | 47.2 2 1 | 58.9 2 1 | | | |
| COMPRESSOR Type...R/s (Qty Cylinder) Compressor* Model No. 06E | Std | (4) A1 | (4) B1 | (4) A1 | (6) B1 | (6) A1 | (6) B1 | (6) A1 | (6) B1 |
| (Qty Cylinder) Compressor* Model No. 06E | Std | 250 | 250 | 250 | 265 | 265 | 275 | 275 | 299 |
| Oil Charge (L) | Opt | (4) A1 | (4) A2 | (6) A1 | (4) A2 | (6) A1 | (6) A2 | (6) A1 | (6) A2 |
| Capacity Control Steps† | Opt | 250 | 250 | 265 | 250 | 275 | 265 | 299 | 275 |
| | Std | 8.0 | 8.0 | 8.0 | 9.9 | 9.9 | 9.9 | 9.0 | 9.0 |
| | Opt | 8.0 | 8.0 | 9.9 | 8.0 | 9.9 | 9.9 | 9.0 | 9.0 |
| CONDENSER FANS (6 Blade) — 50 Hz | | Reciprocating Semi-Hermetic...29.2 @ 60 Hz; 24.3 @ 50 Hz | | | | | | | |
| Qty...Dia (mm) | | 4...762 | | | 6...762 | | | | |
| Airflow (L/s) | | 16,500 | | | 24,500 | | | | |
| Speed (R/s) | | 15.8 | | | 15.8 | | | | |
| Total Power (kW) | | 6.2 | | | 9.3 | | | | |
| CONDENSER FANS (6 Blade) — 60 Hz | | Enhanced Copper Tubes, Aluminum Lanced Fin | | | | | | | |
| Qty...Dia (mm) | | 4...762 | | | 6...762 | | | | |
| Airflow (L/s) | | 16,500 | | | 24,500 | | | | |
| Speed (R/s) | | 19.0 | | | 19.0 | | | | |
| Total Power (kW) | | 6.2 | | | 9.3 | | | | |
| CONDENSER COIL | | Enhanced Copper Tubes, Aluminum Lanced Fin | | | | | | | |
| Rows...Fins per m | | 2...669 | 2...669 | 3...669 | 2...782 | 3...669 | | | |
| Face Area (sq m) | | 7.48 | 7.48 | 7.48 | 10.84 | 10.84 | | | |
| Storage Capacity (Kg per Circuit) at 48.9 C | | 16 | 16 | 25 | 25 | 36 | | | |
| CONNECTIONS | | | | | | | | | |
| Suction, ODF (in.)** | | 2 1/8 | | | | | | | |
| Liquid, ODF (in.)** | | 7/8 | | | | | | | |
| Hot Gas Bypass, ODF (in.) | | 5/8 | | | | | | | |

LEGEND

Cu-Al — Copper tubes with aluminum fins
 Cu-Cu — Copper tubes with copper fins
 ODF — Outside Diameter, Female
 Opt — Optional Single-Circuit Units
 Std — Standard Dual-Circuit Units

For single-circuit units, suction ODF is 2 1/8 in. (66.7 mm) and liquid ODF is 1 1/8 in. (28.6 mm). **Single circuits have a factory-installed manifold; no field modification is required.

NOTES:

1. Certified dimensional drawings available on request.
2. Equivalent connection values in mm are as follows:

| in. | mm |
|-------|------|
| 5/8 | 15.9 |
| 7/8 | 22.2 |
| 2 1/8 | 54.0 |

*Compressor A1 is lead on standard and optional single-circuit units.
 †Capacity control steps listed are for constant-volume units with no accessories. Refer to Table 19A or 19B, page 48, for additional system capacity information.

Table 4A — Units 38AH094-134 Physical Data — 50/60 Hz (English)

| 38AH | 094 | 104 | 124 | | 134 | | | | | | | | | | | |
|---|--|---------------------|---------------------|---------------------|---------------------|---------------------|---------------------|---------------------|---------------------|---------------------|---------------------|---------------------|---------------------|--------|--------|--------|
| | | | 124A | 124B | 134A | 134B | | | | | | | | | | |
| OPERATING WEIGHT WITH REFRIGERANT (Approx) — Lb | Cu-AI Cu-Cu | 5088 5813 | 5435 6160 | 3630* 4063* | 3630* 4063* | 3630* 4063* | 3877* 4294* | | | | | | | | | |
| SHIP WEIGHT WITH COIL PROTECTION AND SKID (Approx) — Lb | Cu-AI Cu-Cu | 5630 6355 | 5990 6715 | 3907* 4340* | 3907* 4340* | 3907* 4340* | 4080* 4497* | | | | | | | | | |
| TYPICAL OPERATING REFRIGERANT CHARGE (Approx) — Lb | R-22 | | | | | | | | | | | | | | | |
| Qty of Circuits | 148 2 | 135 2 | 88 1 | 88 1 | 88 1 | 104 1 | | | | | | | | | | |
| COMPRESSOR Type...Rpm (Qty Cylinder) Compressor† Model No. 06E Oil Charge (Pt) Capacity Control Steps** | Reciprocating Semi-Hermetic...1750 @ 60 Hz; 1460 @ 50 Hz | | | | | | | | | | | | | | | |
| | (6)A1 -275 21 | (4)A2 -250 17 | (6)B1 -299 19 | (6)A1 -265 21 | (4)A2 -250 17 | (6)B1 -265 21 | (6)B2 -265 21 | (6)A1 -275 21 | (6)A2 -265 21 | (6)A1 -275 21 | (6)A2 -265 21 | (6)A1 -299 19 | (6)A2 -275 21 | | | |
| CONDENSER FANS (6 Blade) — 60 Hz | Qty...Dia (in.) | | 6...30 | 6...30 | 4...30 | 4...30 | 4...30 | 6...30 | Airflow (Cfm) | | 52,000 | 52,000 | 35,000 | 35,000 | 35,000 | 52,000 |
| | Speed (Rpm) | | 1140 | 1140 | 1140 | 1140 | 1140 | 1140 | Total Power (kW) | | 9.4 | 9.5 | 6.4 | 6.4 | 6.4 | 9.2 |
| CONDENSER FANS (6 Blade) — 50 Hz | Qty...Dia (in.) | | 6...30 | 6...30 | 4...30 | 4...30 | 4...30 | 6...30 | Airflow (Cfm) | | 52,000 | 52,000 | 35,000 | 35,000 | 35,000 | 52,000 |
| | Speed (Rpm) | | 950 | 950 | 950 | 950 | 950 | 950 | Total Power (kW) | | 9.4 | 9.5 | 6.4 | 6.4 | 6.4 | 9.2 |
| CONDENSER COIL | Enhanced Copper Tubes, Aluminum Lanced Fin | | | | | | | | | | | | | | | |
| Rows...Fins per in. | 3...17 | 3...17 | 3...17 | 3...17 | 3...17 | 3...17 | 3...17 | 2...19 | Face Area (sq ft) | | 128.3 | 128.3 | 80.5 | 80.5 | 80.5 | 116.7 |
| Storage Capacity (Lb per circuit) at 120 F | 178 | 178 | 178 | 110 | 110 | 110 | 110 | 110 | | | | | | | | |
| CONNECTIONS | | | | | | | | | | | | | | | | |
| Suction, ODF (in.) | 2½ | 2½ | 2½ | 2½ | 2½ | 2½ | 2½ | 2½ | Liquid, ODF (in.) | | 7⁄8 | 7⁄8 | 1½ | 1½ | 1½ | 1½ |
| Hot Gas Bypass, ODF (in.) | 5⁄8 | 5⁄8 | 5⁄8 | 5⁄8 | 5⁄8 | 5⁄8 | 5⁄8 | 5⁄8 | | | | | | | | |

Table 4B — Units 38AH094-134 Physical Data — 50/60 Hz (SI)

| 38AH | 094 | 104 | 124 | | 134 | | | | | | | | | | | |
|--|--|--------------------|--------------------|---------------------|--------------------|---------------------|---------------------|---------------------|---------------------|---------------------|---------------------|--------------------|---------------------|--------|--------|--------|
| | | | 124A | 124B | 134A | 134B | | | | | | | | | | |
| OPERATING WEIGHT WITH REFRIGERANT (Approx) — Kg | Cu-AI Cu-Cu | 2308 2637 | 2465 2794 | 1647* 1843* | 1647* 1843* | 1647* 1843* | 1759* 1948* | | | | | | | | | |
| SHIP WEIGHT WITH COIL PROTECTION AND SKID (Approx) — Kg | Cu-AI Cu-Cu | 2554 2883 | 2717 3046 | 1860* 1968* | 1860* 1968* | 1860* 1968* | 1851* 1968* | | | | | | | | | |
| TYPICAL OPERATING REFRIGERANT CHARGE (Approx) — Kg | R-22 | | | | | | | | | | | | | | | |
| Qty of Circuits | 67.1 2 | 61.2 2 | 39.9 1 | 39.9 1 | 39.9 1 | 47.2 1 | | | | | | | | | | |
| COMPRESSOR Type...R/s (Qty Cylinder) Compressor† Model No. 06E Oil Charge (L) Capacity Control Steps** | Reciprocating Semi-Hermetic...29.2 @ 60 Hz; 24.3 @ 50 Hz | | | | | | | | | | | | | | | |
| | (6)A1 -275 10 | (4)A2 -250 8 | (6)B1 -299 9 | (6)A1 -265 10 | (4)A2 -250 8 | (6)B1 -265 10 | (6)B2 -265 10 | (6)A1 -275 10 | (6)A2 -265 10 | (6)A1 -275 10 | (6)A2 -265 10 | (6)A1 -299 9 | (6)A2 -275 10 | | | |
| CONDENSER FANS (6 Blade) — 60 Hz | Qty...Dia (mm) | | 6...762 | 6...762 | 4...762 | 4...762 | 4...762 | 6...762 | Airflow (L/s) | | 24,544 | 24,544 | 16,520 | 16,520 | 16,520 | 24,544 |
| | Speed (R/s) | | 19 | 19 | 19 | 19 | 19 | 19 | Total Power (kW) | | 9.4 | 9.5 | 6.4 | 6.4 | 6.4 | 9.2 |
| CONDENSER FANS (6 Blade) — 50 Hz | Qty...Dia (mm) | | 6...762 | 6...762 | 4...762 | 4...762 | 4...762 | 6...762 | Airflow (L/s) | | 24,544 | 24,544 | 16,520 | 16,520 | 16,520 | 24,544 |
| | Speed (R/s) | | 15.8 | 15.8 | 15.8 | 15.8 | 15.8 | 15.8 | Total Power (kW) | | 9.4 | 9.5 | 6.4 | 6.4 | 6.4 | 9.2 |
| CONDENSER COIL | Enhanced Copper Tubes, Aluminum Lanced Fin | | | | | | | | | | | | | | | |
| Rows...Fins per m | 3...669.3 | 3...669.3 | 3...669.3 | 3...669.3 | 3...669.3 | 3...669.3 | 3...669.3 | 2...781.6 | Face Area (sq m) | | 11.9 | 11.9 | 7.5 | 7.5 | 7.5 | 10.8 |
| Storage Capacity (Kg per circuit) at 49 C | 81 | 81 | 81 | 50 | 50 | 50 | 50 | 50 | | | | | | | | |
| CONNECTIONS | | | | | | | | | | | | | | | | |
| Suction, ODF (in.) | 2½ | 2½ | 2½ | 2½ | 2½ | 2½ | 2½ | 2½ | Liquid, ODF (in.) | | 7⁄8 | 7⁄8 | 1½ | 1½ | 1½ | 1½ |
| Hot Gas Bypass, ODF (in.) | 5⁄8 | 5⁄8 | 5⁄8 | 5⁄8 | 5⁄8 | 5⁄8 | 5⁄8 | 5⁄8 | | | | | | | | |

LEGEND

Cu-AI — Copper Tubes with Aluminum Fins
Cu-Cu — Copper Tubes with Copper Fins
ODF — Outside Diameter, Female

*Includes piping and trim kit.

†Compressors are shipped with minimum oil charge.

**Capacity control steps listed are for constant volume units with no accessories. Refer to Table 20, page 48, for additional system capacity information.

NOTES:

- Unit 38AH124 consists of one 124A module and one 124B module. Unit 38AH134 consists of one 134A module and one 134B module.
- Certified dimensional drawings available on request.
- Equivalent connection values in mm are as follows:

| in. | mm |
|-----|------|
| 5⁄8 | 15.9 |
| 7⁄8 | 22.2 |
| 1½ | 28.6 |
| 2½ | 54.0 |
| 3 | 66.7 |

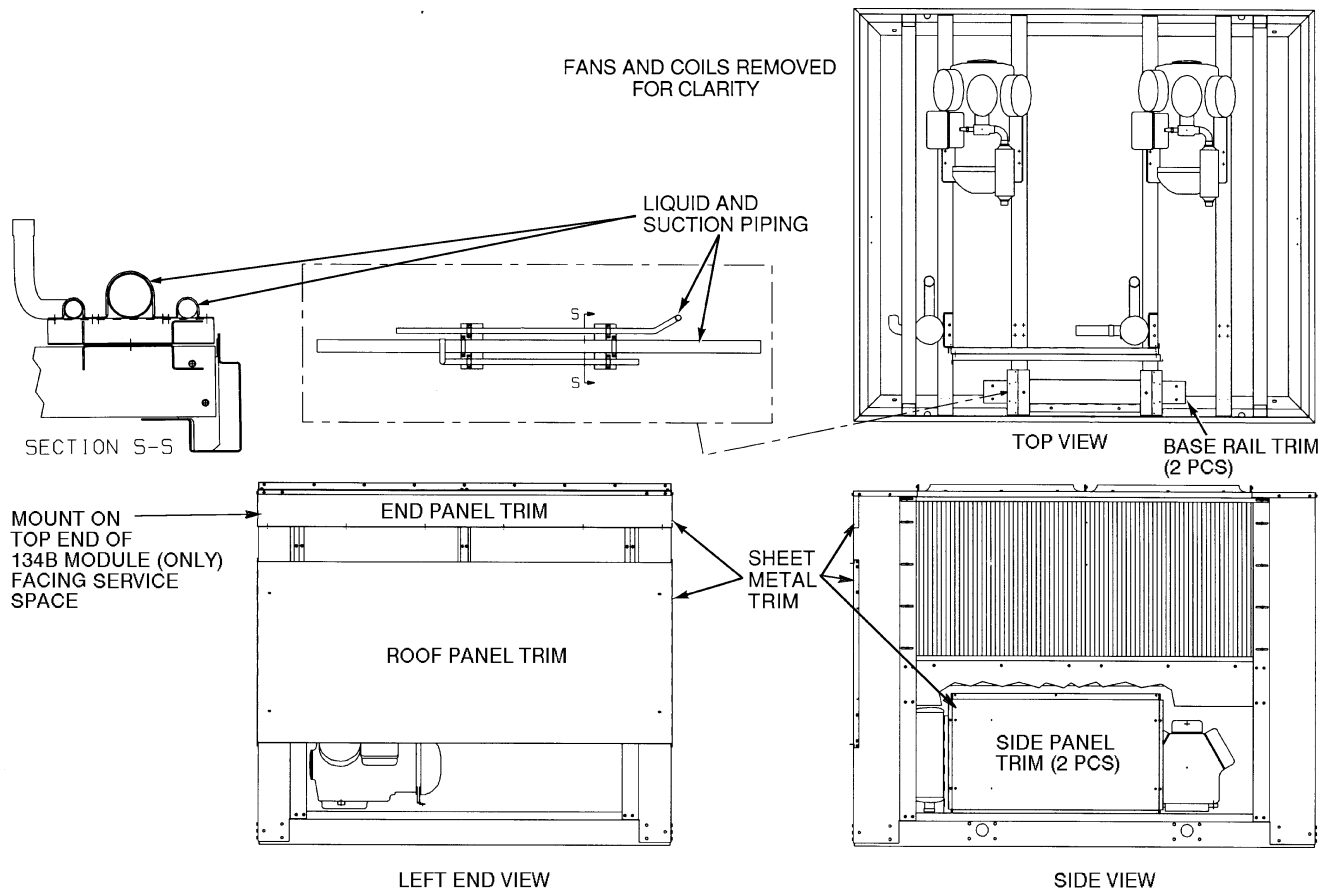


Fig. 7 — Modules 38AH124A or 134A — Shipping Locations of Piping and Sheet Metal Trim Kit

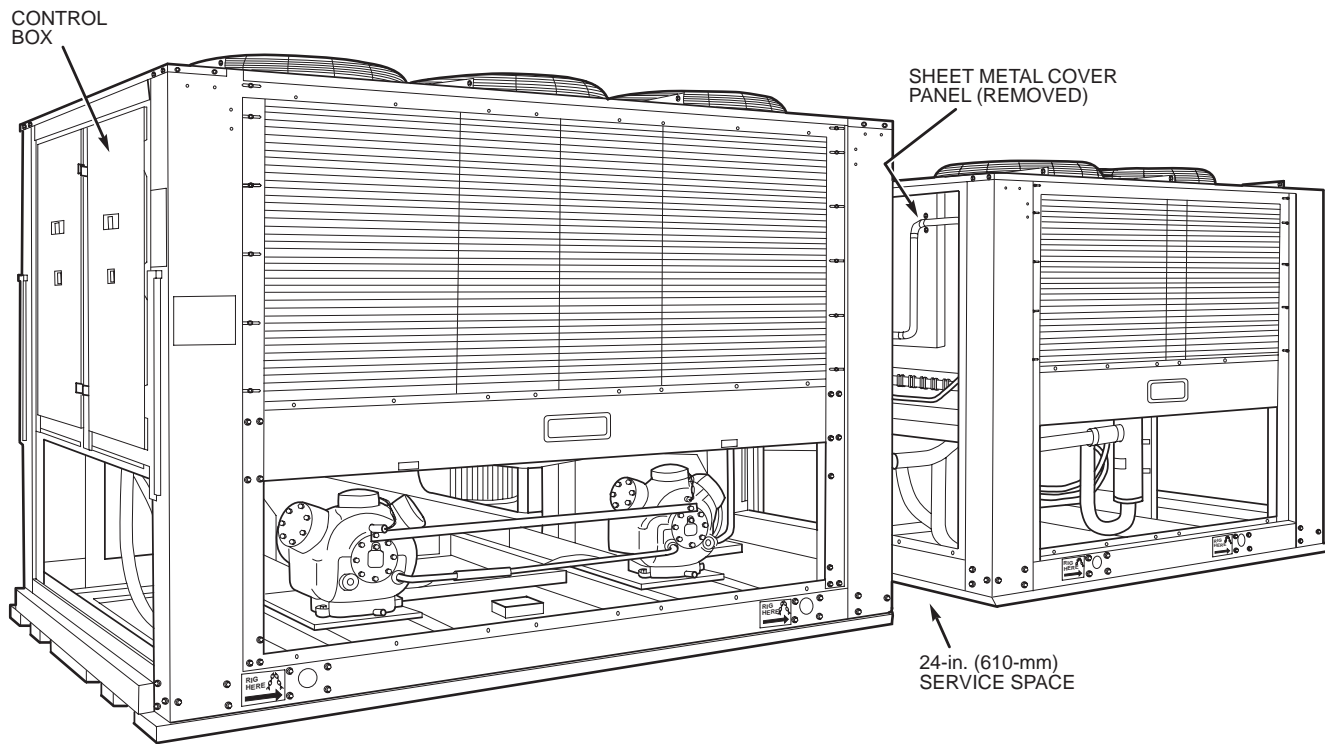


Fig. 8 — Correct Placement of Modules Without Piping and Sheet Metal Trim (Unit 38AH134 Shown)

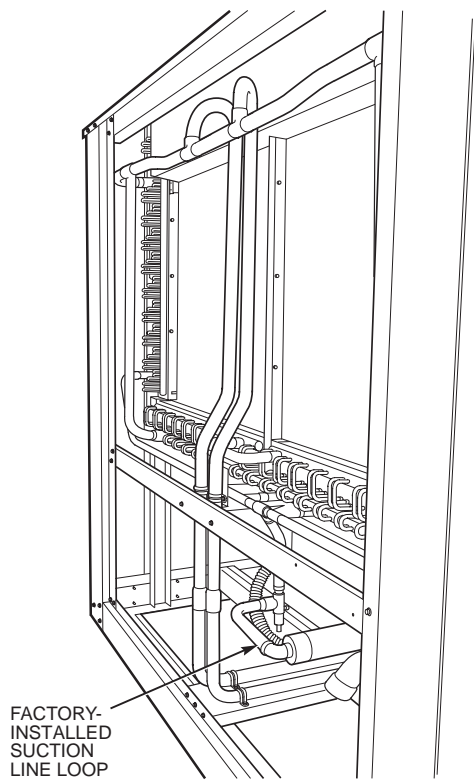


Fig. 9A — Typical Module with Cover Panels Removed

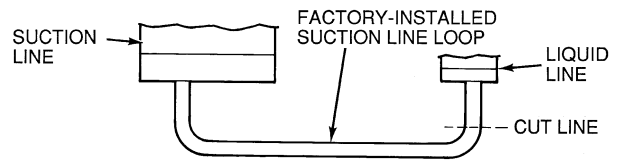
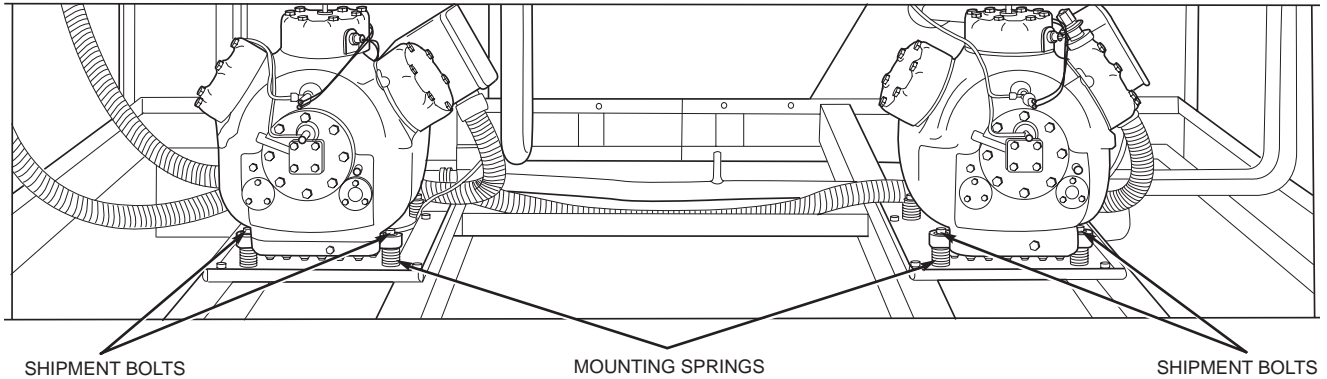


Fig. 9B — Field-Installed Suction Line Loop

38AH044-084,124,134



38AH094,104

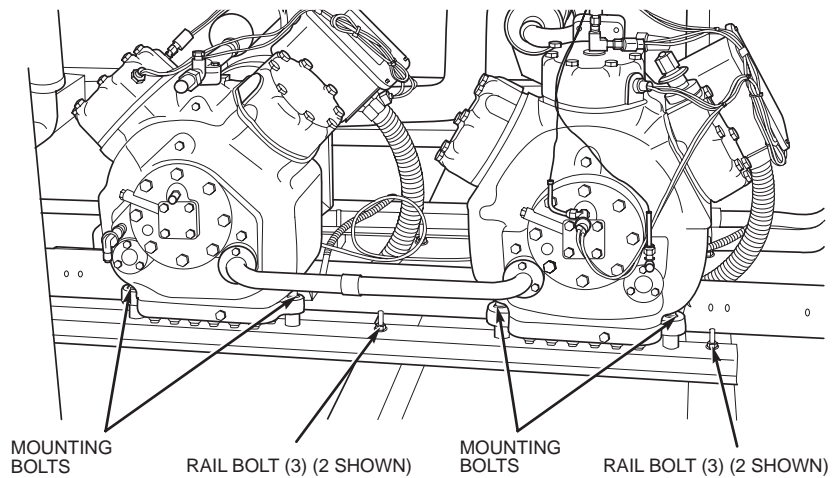


Fig. 10 — Outer View, Compressor Mounting

Step 3 — Make Refrigerant Piping Connections

⚠ CAUTION

The field-supplied liquid line solenoid valve *must* be installed at the evaporator to avoid possible compressor damage during unit operation. See Fig. 11 (for 38AH044-084 dual-circuit and 38AH094-134 units), or Fig. 12 (for 38AH044-084 optional single-circuit units).

The units have large suction lines to minimize friction losses. The units also have the ability to operate at low capacity. Because of these capabilities, use special care with suction piping and suction risers to ensure proper compressor oil return under all operating conditions. Maximum allowable vertical separation between the condensing unit and the evaporator is shown in Table 5. Size suction lines in accordance with Tables 6A or 6B through 9A or 9B and Fig. 13. Mount liquid line solenoid valve just ahead of the TXVs (thermostatic expansion valves) which will be mounted at the evaporator. See Fig. 11 (for 38AH044-084 dual-circuit and 38AH094-134 units) or Fig. 12 (for 38AH044-084 optional single-circuit units).

To achieve good mixing of the refrigerant leaving the evaporator suction header for proper sensing by the TXV bulb:

1. Install a minimum of two 90-degree elbows upstream of the TXV bulb location. See Fig. 14 (for 38AH044-084 dual-circuit and 38AH094-134 units) or Fig. 15 (for 38AH044-084 optional single-circuit units).
2. Locate the TXV bulb on a vertical riser, where possible. If a horizontal location is necessary, secure the bulb at approximately the 4 o'clock position.
3. Size the suction line from the evaporator to the common suction line to achieve high refrigerant velocity. See Tables 6A or 6B through 9A or 9B and Fig. 13.

If an oil return connection at the bottom of the suction header is supplied with an evaporator, tee-in this connection ahead of first mixing elbow. See Fig. 14 (for 38AH044-084 dual-circuit and 38AH094-134 units) or Fig. 15 (for 38AH044-084 optional single-circuit units). When the compressor is below the evaporator, the riser at the evaporator should extend to the top of the evaporator section. After the riser is installed, the suction line can elbow down immediately.

Install a field-supplied filter drier and sight glasses in each refrigerant system. Select the filter drier for maximum unit capacity and minimum pressure drop. Figure 11 (for 38AH044-084 dual-circuit and 38AH094-134 units) or Fig. 12 (for

38AH044-084 optional single-circuit units) shows required location of solenoid valves and recommended locations for the filter driers and sight glasses. Complete the refrigerant piping from the evaporator to the condenser before opening the liquid and suction lines at the condenser.

Table 5 — Liquid Lift

| UNIT 38AH | MAXIMUM LIQUID LIFT | | | |
|--------------|---------------------|------|-------|------|
| | 60 Hz | | 50 Hz | |
| | Ft | M | Ft | M |
| 044 | 69 | 21.0 | 57.5 | 17.5 |
| 054 | 75 | 23.0 | 75.0 | 23.0 |
| 064 | 75 | 23.0 | 65.0 | 19.8 |
| 074 | 45 | 13.7 | 37.5 | 11.4 |
| 084 | 75 | 23.0 | 75.0 | 23.0 |
| 094 | 55 | 16.7 | 46.0 | 14.0 |
| 104 | 50 | 15.2 | 42.0 | 12.8 |
| 124 | 75 | 23.0 | 65.0 | 19.8 |
| 134 | 45 | 13.7 | 37.5 | 11.4 |

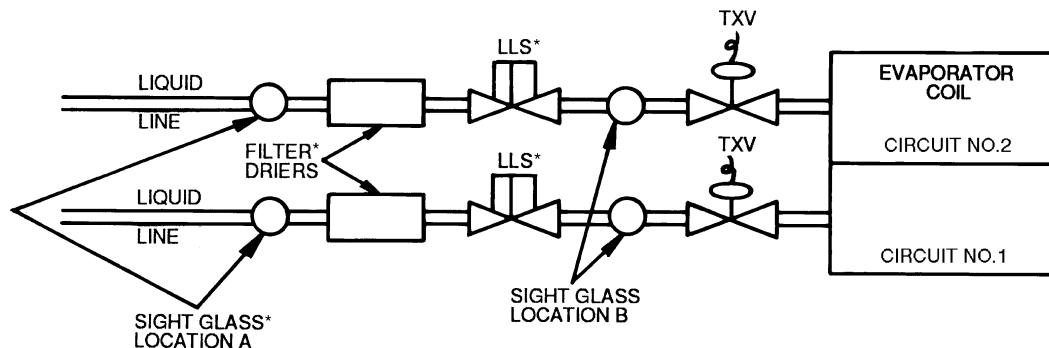
UNITS 38AH044-084 — Relieve the pressure caused by the holding charge into a refrigerant recovery system. Uncap the suction line and cut the run-around tube at the liquid line as close to the loop elbow as possible. This will leave approximately 2 in. (50 mm) of straight tube for liquid line connection.

IMPORTANT: Protect the liquid valves from the heat of brazing.

Leak test the entire system by using soap bubbles and nitrogen or R-22 with an electronic leak detector.

Purge nitrogen or reclaim R-22 from system after completion of leak-checking procedure. Repair leak if one is found. When finished, evacuate and dehydrate system using the methods described in Carrier GTAC II (General Training Air Conditioning II), Module 4, System Dehydration.

UNITS 38AH094-134 — Relieve the R-22 holding charge of each circuit into a refrigerant recovery system. Remove the liquid line to factory-installed suction line loop by cutting the loop at the liquid valve. (See Fig. 9A and 9B.) Cut as close to the 90-degree bend in the loop as possible. The remaining tube piece in the valve will be used for brazing the liquid line. Unbrazed and remove the cap from the liquid line. For 38AH094 and 104 units, sweat-connect the liquid and suction lines from the evaporator. For 38AH124 and 134 units, see Piping Kit Connections on page 21.

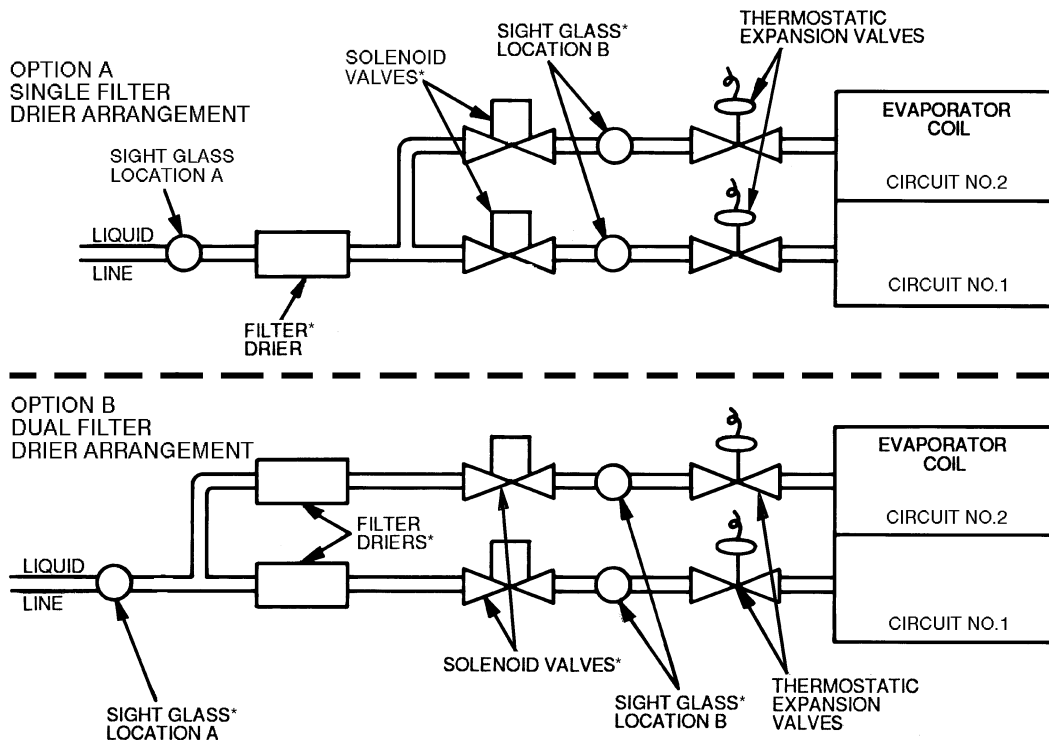


LEGEND

- LLS — Liquid Line Solenoid
- TXV — Thermostatic Expansion Valve

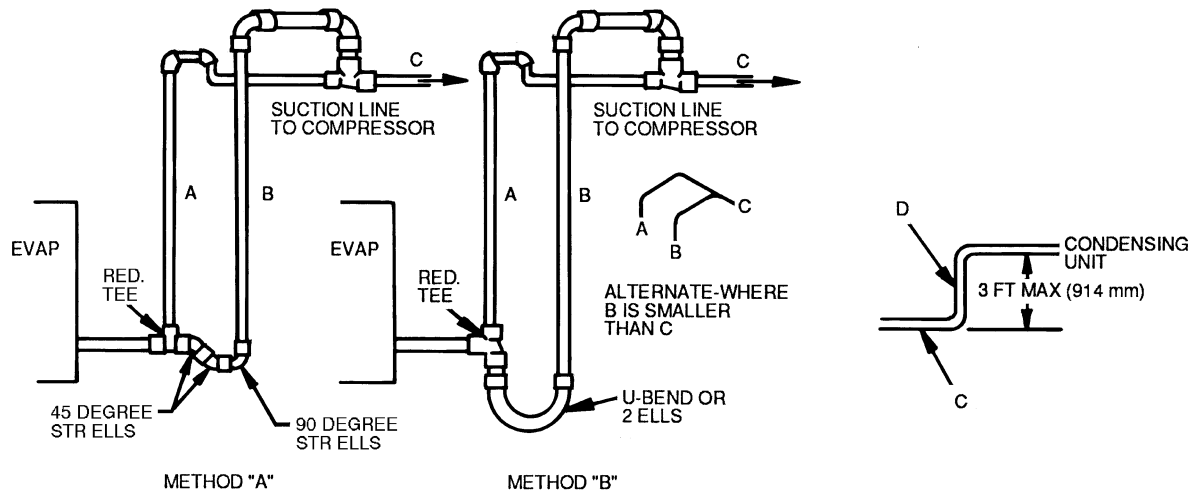
*Field-Supplied.

Fig. 11 — Required Location of Solenoid Valves and Recommended Filter Drier and Sight Glass Locations for 38AH044-084 Dual-Circuit and 38AH094-134 Units



*Field-Supplied.

Fig. 12 — Required Location of Solenoid Valves and Recommended Filter Drier and Sight Glass Locations for 38AH044-084 Optional Single-Circuit Units



LEGEND

- A** — Pipe A, Suction Riser, without Trap
- B** — Pipe B, Suction Riser with Trap
- C** — Suction Line to Condensing Unit
- D** — Pipe D, Suction Riser Short Lift
- RED.** — Reducer
- STR** — Street

NOTES:

1. Short riser, pipe D, is used when routing suction line to condensing unit connection. See table at right.
2. See Tables 6A-9B for values of A, B, and C.

| UNIT 38AH | PIPE D DIAMETER | | | | | |
|--------------|-------------------------------|-----|-------------------------------|-----|---------------------------------|-----|
| | Dual Circuit* | | | | Single Circuit* | |
| | A | | B | | | |
| in. | mm | in. | mm | in. | mm | |
| 044 | 1 ⁵ / ₈ | 41 | 1 ⁵ / ₈ | 41 | 2 ¹ / ₈ | 54 |
| 054 | 1 ⁵ / ₈ | 41 | 1 ⁵ / ₈ | 41 | 2 ¹ / ₈ | 54 |
| 064 | 1 ⁵ / ₈ | 41 | 2 ¹ / ₈ | 54 | 2 ¹ / ₈ | 54 |
| 074 | 2 ¹ / ₈ | 54 | 2 ¹ / ₈ | 54 | 2 ¹ / ₈ | 54 |
| 084 | 2 ¹ / ₈ | 54 | 2 ¹ / ₈ | 54 | 2 ⁵ / ₈ † | 67† |
| 094, 104 | 2 ¹ / ₈ | 54 | 2 ¹ / ₈ | 54 | — | — |
| 124, 134 | 2 ⁵ / ₈ | 67 | 2 ⁵ / ₈ | 67 | — | — |

*Maximum length of riser is 3 ft (914 mm).

†Double suction riser required if accessory unloader is field installed.

Fig. 13 — Double Suction Riser Construction

Table 6A — Refrigerant Piping Requirements — 38AH044-104 Dual-Circuit Units — 60 Hz

| UNIT 38AH | | TOTAL LINEAR LENGTH OF INTERCONNECTING PIPE — FT (M) | | | | | | | | | | | |
|--------------|-------|--|-------|---------------------|-------|----------------------|--------|-----------------------|--------|------------------------|---------|------------------------|---------|
| | | 15-25 (4.6-7.6) | | 25-50 (7.6-15.2) | | 50-75 (15.2-22.9) | | 75-100 (22.9-30.5) | | 100-150 (30.5-45.7) | | 150-200 (45.7-61.0) | |
| | | L | S | L | S | L | S | L | S | L | S | L | S |
| 044 | Ckt A | 5/8 | 1 1/8 | 7/8 | 1 5/8 | 7/8 | 2 1/8 | 7/8 | 2 1/8 | 7/8 | 2 1/8 | 7/8 | 2 1/8 |
| | Ckt B | 5/8 | 1 1/8 | 7/8 | 1 5/8 | 7/8 | 2 1/8 | 7/8 | 2 1/8 | 7/8 | 2 1/8 | 7/8 | 2 1/8 |
| 054 | Ckt A | 5/8 | 1 1/8 | 7/8 | 1 5/8 | 7/8 | 2 1/8 | 7/8 | 2 1/8 | 7/8 | 2 1/8 | 7/8 | 2 1/8 |
| | Ckt B | 7/8 | 1 1/8 | 7/8 | 2 1/8 | 7/8 | 2 1/8 | 1 1/8 | 2 1/8 | 1 1/8 | 2 1/8 | 1 1/8 | 2 5/8* |
| 064 | Ckt A | 7/8 | 1 5/8 | 7/8 | 2 1/8 | 7/8 | 2 1/8 | 7/8 | 2 1/8 | 1 1/8 | 2 1/8 | 1 1/8 | 2 5/8† |
| | Ckt B | 7/8 | 2 1/8 | 7/8 | 2 1/8 | 7/8 | 2 1/8 | 1 1/8 | 2 1/8 | 1 1/8 | 2 5/8 | 1 1/8 | 2 5/8 |
| 074 | Ckt A | 7/8 | 2 1/8 | 7/8 | 2 1/8 | 7/8 | 2 1/8 | 1 1/8 | 2 1/8 | 1 1/8 | 2 5/8† | 1 1/8 | 2 5/8† |
| | Ckt B | 7/8 | 2 1/8 | 1 1/8 | 2 1/8 | 1 1/8 | 2 1/8 | 1 1/8 | 2 5/8 | 1 3/8 | 2 5/8 | 1 3/8 | 2 5/8 |
| 084 | Ckt A | 7/8 | 2 1/8 | 1 1/8 | 2 1/8 | 1 1/8 | 2 1/8 | 1 1/8 | 2 5/8† | 1 3/8 | 2 5/8† | 1 3/8 | 2 5/8† |
| | Ckt B | 7/8 | 2 1/8 | 1 1/8 | 2 1/8 | 1 1/8 | 2 1/8 | 1 1/8 | 2 5/8 | 1 3/8 | 2 5/8 | 1 3/8 | 2 5/8 |
| 094 | Ckt A | 7/8 | 2 1/8 | 1 1/8 | 2 1/8 | 1 1/8 | 2 5/8† | 1 1/8 | 2 5/8† | 1 3/8 | 2 5/8† | 1 3/8 | 3 1/8** |
| | Ckt B | 7/8 | 2 1/8 | 7/8 | 2 1/8 | 1 1/8 | 2 1/8 | 1 1/8 | 2 5/8 | 1 1/8 | 2 5/8 | 1 3/8 | 2 5/8 |
| 104 | Ckt A | 7/8 | 2 1/8 | 1 1/8 | 2 1/8 | 1 1/8 | 2 5/8† | 1 1/8 | 2 5/8† | 1 3/8 | 2 5/8† | 1 3/8 | 3 1/8** |
| | Ckt B | 7/8 | 2 1/8 | 1 1/8 | 2 1/8 | 1 1/8 | 2 5/8 | 1 1/8 | 2 5/8 | 1 3/8 | 3 1/8** | 1 3/8 | 3 1/8** |

LEGEND

L — Liquid Line
S — Suction Line

*Double suction riser required on units with field installed unloader on circuit B compressor if condensing unit is elevated above evaporator.

†Double suction riser required on units with field installed unloader on circuit B compressor if condensing unit is elevated above evaporator.

**Double suction riser required on all unit configurations if condensing unit is elevated above evaporator.

NOTES:

1. Addition of 2 unloaders to circuit B compressor is not recommended.
2. 38AH094 and 38AH104 piping sizes apply only to factory supplied unit configurations. They do NOT take into account any field installed unloaders.
3. Piping sizes are based on unit operation above 40 F (4.4 C) saturated suction temperature (SST). When operating below 40 F (4.4 C), refer to Carrier System Design Manual, E20-II® piping design program, or ASHRAE Handbook to select proper line sizes.
4. Pipe sizes are based on the total linear length shown for each column, plus a 50% allowance for fittings.

5. Suction and liquid line sizing is based on pressure drop equivalent to 2 F (1.1 C) at nominal rating conditions. Higher pressure drop design criteria may allow selection of smaller pipe sizes, but at a penalty of decreased system capacity and efficiency.
6. Double suction risers may be required if condensing unit is elevated above the evaporator. See footnotes and double suction riser table below.
7. Refer to Carrier System Design Manual or to E20-II design programs for further information on selecting pipe sizes for split systems.
8. All pipe sizes are OD inches. Equivalent sizes in millimeters follow:

| in. | mm |
|-------|------|
| 5/8 | 15.9 |
| 7/8 | 22.2 |
| 1 1/8 | 28.6 |
| 1 3/8 | 34.9 |
| 1 5/8 | 41.3 |
| 2 1/8 | 54.0 |
| 2 5/8 | 66.7 |
| 3 1/8 | 79.4 |

Table 6B — Refrigerant Piping Requirements for Double Suction Risers, 38AH054-104 Dual-Circuit Units — 60 Hz

| UNIT 38AH | | TOTAL LINEAR LENGTH OF INTERCONNECTING PIPE — FT (M) | | | | | | | | | | | |
|--------------|-------|--|-------|-------|-----------------------|-------|-------|------------------------|-------|-------|------------------------|-------|-------|
| | | 50-75 (15.2-22.9) | | | 75-100 (22.9-30.5) | | | 100-150 (30.5-45.7) | | | 150-200 (45.7-61.0) | | |
| | | A | B | C | A | B | C | A | B | C | A | B | C |
| 054 | Ckt A | — | — | — | — | — | — | — | — | — | — | — | — |
| | Ckt B | — | — | — | — | — | — | — | — | — | 1 5/8 | 2 1/8 | 2 5/8 |
| 064 | Ckt A | — | — | — | — | — | — | — | — | — | 1 5/8 | 2 1/8 | 2 5/8 |
| | Ckt B | — | — | — | — | — | — | — | — | — | — | — | — |
| 074 | Ckt A | — | — | — | — | — | — | 1 5/8 | 2 1/8 | 2 5/8 | 1 5/8 | 2 1/8 | 2 5/8 |
| | Ckt B | — | — | — | — | — | — | — | — | — | — | — | — |
| 084 | Ckt A | — | — | — | 1 5/8 | 2 1/8 | 2 5/8 | 1 5/8 | 2 1/8 | 2 5/8 | 1 5/8 | 2 1/8 | 2 5/8 |
| | Ckt B | — | — | — | — | — | — | — | — | — | — | — | — |
| 094 | Ckt A | 1 5/8 | 2 1/8 | 2 5/8 | 1 5/8 | 2 1/8 | 2 5/8 | 1 5/8 | 2 1/8 | 2 5/8 | 1 5/8 | 2 5/8 | 3 1/8 |
| | Ckt B | — | — | — | — | — | — | — | — | — | — | — | — |
| 104 | Ckt A | 1 3/8 | 2 1/8 | 2 5/8 | 1 3/8 | 2 1/8 | 2 5/8 | 1 3/8 | 2 1/8 | 2 5/8 | 1 5/8 | 2 5/8 | 3 1/8 |
| | Ckt B | — | — | — | — | — | — | — | — | — | — | — | — |

LEGEND

— — Not Required
Pipe A — Suction Riser Without Trap
Pipe B — Suction Riser With Trap
Pipe C — Suction Line to Condensing Unit

NOTES:

1. See Refrigerant Piping Requirements table at top of page to determine need for double suction risers.
2. Pipe sizes are based on the total linear length, shown for each column, plus a 50% allowance for fittings.

3. Suction and liquid line sizing is based on pressure drop equivalent to 2 F (1.1 C) at nominal rating conditions. Higher design pressure drop criteria may allow selection of smaller pipe sizes but at a penalty of decreased system capacity and efficiency.
4. Refer to Carrier System Design Manual or to E20-II design programs for further information on selecting pipe sizes for split systems.
5. All pipe sizes are OD inches. See Table 6A notes for metric equivalents.
6. Refer to Fig. 13 for double suction riser construction.

Table 7A — Refrigerant Piping Requirements, 38AH044-104 Dual-Circuit Units — 50 Hz

| UNIT 38AH | | TOTAL LINEAR LENGTH OF INTERCONNECTING PIPE — FT (M) | | | | | | | | | | | |
|--------------|-------|--|-------|---------------------|-------|----------------------|---------|-----------------------|---------|------------------------|---------|------------------------|---------|
| | | 15-25 (4.6-7.6) | | 25-50 (7.6-15.2) | | 50-75 (15.2-22.9) | | 75-100 (22.9-30.5) | | 100-150 (30.5-45.7) | | 150-200 (45.7-61.0) | |
| | | L | S | L | S | L | S | L | S | L | S | L | S |
| 044 | Ckt A | 5/8 | 1 3/8 | 7/8 | 1 5/8 | 7/8 | 1 5/8 | 7/8 | 2 1/8 | 7/8 | 2 1/8 | 7/8 | 2 1/8 |
| | Ckt B | 5/8 | 1 3/8 | 7/8 | 1 5/8 | 7/8 | 1 5/8 | 7/8 | 2 1/8 | 7/8 | 2 1/8 | 7/8 | 2 1/8 |
| 054 | Ckt A | 5/8 | 1 3/8 | 7/8 | 1 5/8 | 7/8 | 1 5/8 | 7/8 | 2 1/8 | 7/8 | 2 1/8 | 7/8 | 2 1/8 |
| | Ckt B | 7/8 | 1 5/8 | 7/8 | 1 5/8 | 7/8 | 2 1/8 | 7/8 | 2 1/8 | 1 1/8 | 2 1/8 | 1 1/8 | 2 5/8*† |
| 064 | Ckt A | 7/8 | 1 5/8 | 7/8 | 1 5/8 | 7/8 | 2 1/8† | 7/8 | 2 1/8† | 1 1/8 | 2 1/8† | 1 1/8 | 2 5/8** |
| | Ckt B | 7/8 | 1 5/8 | 7/8 | 2 1/8 | 7/8 | 2 1/8 | 7/8 | 2 1/8 | 1 1/8 | 2 5/8* | 1 1/8 | 2 5/8* |
| 074 | Ckt A | 7/8 | 1 5/8 | 7/8 | 2 1/8 | 7/8 | 2 1/8 | 7/8 | 2 1/8 | 1 1/8 | 2 5/8† | 1 1/8 | 2 5/8† |
| | Ckt B | 7/8 | 2 1/8 | 7/8 | 2 1/8 | 1 1/8 | 2 1/8 | 1 1/8 | 2 5/8 | 1 1/8 | 2 5/8 | 1 1/8 | 2 5/8 |
| 084 | Ckt A | 7/8 | 2 1/8 | 7/8 | 2 1/8 | 1 1/8 | 2 1/8 | 1 1/8 | 2 5/8† | 1 1/8 | 2 5/8† | 1 1/8 | 2 5/8† |
| | Ckt B | 7/8 | 2 1/8 | 7/8 | 2 1/8 | 1 1/8 | 2 1/8 | 1 1/8 | 2 5/8 | 1 1/8 | 2 5/8 | 1 1/8 | 2 5/8 |
| 094 | Ckt A | 7/8 | 2 1/8 | 1 1/8 | 2 1/8 | 1 1/8 | 2 5/8** | 1 1/8 | 2 5/8** | 1 1/8 | 2 5/8** | 1 3/8 | 3 1/8** |
| | Ckt B | 7/8 | 2 1/8 | 7/8 | 2 1/8 | 1 1/8 | 2 1/8 | 1 1/8 | 2 5/8*† | 1 1/8 | 2 5/8*† | 1 1/8 | 2 5/8*† |
| 104 | Ckt A | 7/8 | 2 1/8 | 7/8 | 2 1/8 | 1 1/8 | 2 1/8 | 1 1/8 | 2 5/8** | 1 1/8 | 2 5/8** | 1 3/8 | 3 1/8** |
| | Ckt B | 7/8 | 2 1/8 | 1 1/8 | 2 1/8 | 1 1/8 | 2 5/8 | 1 1/8 | 2 5/8 | 1 3/8 | 2 5/8 | 1 3/8 | 3 1/8** |

LEGEND

L — Liquid Line
S — Suction Line

*Double suction riser required on units with field installed unloader on circuit B compressor if condensing unit is elevated above evaporator.

†Double suction riser required on units with field installed unloader on circuit B compressor if condensing unit is elevated above evaporator.

**Double suction riser required on all unit configurations if condensing unit is elevated above evaporator.

NOTES:

1. Addition of 2 unloaders to circuit B compressor is not recommended.
2. 38AH094 and 38AH104 piping sizes apply only to factory supplied unit configurations. They do NOT take into account any field installed unloaders.
3. Piping sizes are based on unit operation above 40 F (4.4 C) saturated suction temperature (SST). When operating below 40 F (4.4 C), refer to Carrier System Design Manual, E20-II® piping design program, or ASHRAE Handbook to select proper line sizes.
4. Pipe sizes are based on the total linear length shown for each column, plus a 50% allowance for fittings.

5. Suction and liquid line sizing is based on pressure drop equivalent to 2 F (1.1 C) at nominal rating conditions. Higher pressure drop design criteria may allow selection of smaller pipe sizes, but at a penalty of decreased system capacity and efficiency.
6. Double suction risers may be required if condensing unit is elevated above the evaporator. See footnotes and double suction riser table below.
7. Refer to Carrier System Design Manual or to E20-II design programs for further information on selecting pipe sizes for split systems.
8. All pipe sizes are OD inches. Equivalent sizes in millimeters follow:

| in. | mm |
|-------|------|
| 5/8 | 15.9 |
| 7/8 | 22.2 |
| 1 1/8 | 28.6 |
| 1 3/8 | 34.9 |
| 1 5/8 | 41.3 |
| 2 1/8 | 54.0 |
| 2 5/8 | 66.7 |
| 3 1/8 | 79.4 |

Table 7B— Refrigerant Piping Requirements for Double Suction Risers, 38AH054-104 Dual-Circuit Units — 50 Hz

| UNIT 38AH | | TOTAL LINEAR LENGTH OF INTERCONNECTING PIPE — FT (M) | | | | | | | | | | | |
|--------------|-------|--|-------|-------|-----------------------|-------|-------|------------------------|-------|-------|------------------------|-------|-------|
| | | 50-75 (15.2-22.9) | | | 75-100 (22.9-30.5) | | | 100-150 (30.5-45.7) | | | 150-200 (45.7-61.0) | | |
| | | A | B | C | A | B | C | A | B | C | A | B | C |
| 054 | Ckt A | — | — | — | — | — | — | — | — | — | — | — | — |
| | Ckt B | — | — | — | — | — | — | — | — | — | 1 5/8 | 2 1/8 | 2 5/8 |
| 064 | Ckt A | 1 3/8 | 1 5/8 | 2 1/8 | 1 3/8 | 1 5/8 | 2 1/8 | 1 5/8 | 1 5/8 | 2 1/8 | 1 5/8 | 2 1/8 | 2 5/8 |
| | Ckt B | — | — | — | — | — | — | 1 5/8 | 2 1/8 | 2 5/8 | 1 5/8 | 2 1/8 | 2 5/8 |
| 074 | Ckt A | — | — | — | — | — | — | 1 5/8 | 2 1/8 | 2 5/8 | 1 5/8 | 2 1/8 | 2 5/8 |
| | Ckt B | — | — | — | — | — | — | — | — | — | — | — | — |
| 084 | Ckt A | — | — | — | 1 5/8 | 2 1/8 | 2 5/8 | 1 5/8 | 2 1/8 | 2 5/8 | 1 5/8 | 2 1/8 | 2 5/8 |
| | Ckt B | — | — | — | — | — | — | — | — | — | — | — | — |
| 094 | Ckt A | 1 3/8 | 2 1/8 | 2 5/8 | 1 3/8 | 2 1/8 | 2 5/8 | 1 5/8 | 2 1/8 | 2 5/8 | 1 5/8 | 2 5/8 | 3 1/8 |
| | Ckt B | — | — | — | 1 3/8 | 2 1/8 | 2 5/8 | 1 5/8 | 2 1/8 | 2 5/8 | 1 5/8 | 2 1/8 | 2 5/8 |
| 104 | Ckt A | — | — | — | 1 3/8 | 2 1/8 | 2 5/8 | 1 5/8 | 2 1/8 | 2 5/8 | 1 5/8 | 2 5/8 | 3 1/8 |
| | Ckt B | — | — | — | — | — | — | — | — | — | 1 5/8 | 2 5/8 | 3 1/8 |

LEGEND

— — Not Required
Pipe A — Suction Riser Without Trap
Pipe B — Suction Riser With Trap
Pipe C — Suction Line to Condensing Unit

NOTES:

1. See Refrigerant Piping Requirements table at top of page to determine need for double suction risers.
2. Pipe sizes are based on the total linear length, shown for each column, plus a 50% allowance for fittings.

3. Suction and liquid line sizing is based on pressure drop equivalent to 2 F (1.1 C) at nominal rating conditions. Higher design pressure drop criteria may allow selection of smaller pipe sizes but at a penalty of decreased system capacity and efficiency.
4. Refer to Carrier System Design Manual or to E20-II design programs for further information on selecting pipe sizes for split systems.
5. All pipe sizes are OD inches. See Table 7A notes for metric equivalents.
6. Refer to Fig. 13 for double suction riser construction.

**Table 8A — Refrigerant Piping Requirements for 38AH044-084
Optional Single-Circuit Units and 38AH124,134
Modular Units (Dual-Circuit) — 60 Hz**

| UNIT 38AH | TOTAL LINEAR LENGTH OF INTERCONNECTING PIPE — FT (M) | | | | | | | | | | | |
|---|--|--------|---------------------|--------|----------------------|--------|-----------------------|--------|------------------------|--------|------------------------|--------|
| | 15-20 (4.6-6.1) | | 20-50 (6.1-15.2) | | 50-75 (15.2-22.9) | | 75-100 (22.9-30.5) | | 100-150 (30.5-45.7) | | 150-200 (45.7-61.0) | |
| | L | S | L | S | L | S | L | S | L | S | L | S |
| 044 | 7/8 | 2 1/8 | 7/8 | 2 1/8 | 1 1/8 | 2 1/8 | 1 1/8 | 2 5/8* | 1 3/8 | 2 5/8* | 1 3/8 | 3 1/8* |
| 054 | 7/8 | 2 1/8 | 1 1/8 | 2 5/8 | 1 1/8 | 2 5/8 | 1 1/8 | 2 5/8 | 1 3/8 | 3 1/8* | 1 3/8 | 3 1/8* |
| 064; Modules 124A, 124B,134A | 1 1/8 | 2 1/8 | 1 1/8 | 2 5/8† | 1 1/8 | 2 5/8† | 1 3/8 | 3 1/8* | 1 3/8 | 3 1/8* | 1 3/8 | 3 1/8* |
| 074; Module 134B | 1 1/8 | 2 1/8 | 1 1/8 | 2 5/8† | 1 3/8 | 3 1/8† | 1 3/8 | 3 1/8† | 1 3/8 | 3 1/8† | 1 5/8 | 3 5/8* |
| 084 | 1 1/8 | 2 5/8† | 1 1/8 | 2 5/8† | 1 3/8 | 3 1/8† | 1 3/8 | 3 1/8† | 1 5/8 | 3 5/8† | 1 5/8 | 3 5/8* |

LEGEND

- CV** — Constant Volume
L — Liquid Line
S — Suction Line
VAV — Variable Air Volume

*Double suction riser required on all units configurations if condensing unit is elevated above evaporator.

†Double suction riser required on units with factory installed VAV option or CV units with additional field installed unloader on circuit A1 (lead) compressor if condensing unit is elevated above evaporator.

NOTES:

1. Addition of field-installed unloaders on A2 (lag) compressor is not recommended.
2. Piping sizes are based on unit operation above 40 F (4.4 C) saturated suction temperature (SST). When operating below 40 F (4.4 C), refer to Carrier System Design Manual, E20-II® piping design program, or ASHRAE Handbook to select proper line sizes.
3. Pipe sizes are based on the total linear length shown for each column, plus a 50% allowance for fittings.
4. Suction and liquid line sizing is based on pressure drop equivalent to 2 F (1.1 C) at nominal rating conditions. Higher pressure drop

design criteria may allow selection of smaller pipe sizes, but at a penalty of decreased system capacity and efficiency.

5. Double suction risers may be required if condensing unit is elevated above the evaporator. See footnotes and double suction riser table below.
6. Refer to Carrier System Design Manual, E20-II design program, or ASHRAE Handbook for further information on selecting pipe sizes for split systems.
7. All pipe sizes are OD inches. Equivalent sizes in millimeters follow:

| in. | mm |
|-------|------|
| 7/8 | 22.2 |
| 1 1/8 | 28.6 |
| 1 3/8 | 34.9 |
| 1 5/8 | 41.3 |
| 2 1/8 | 54.0 |
| 2 5/8 | 66.7 |
| 3 1/8 | 79.4 |
| 3 5/8 | 92.1 |

**Table 8B — Refrigerant Piping Requirements for Double Suction Risers,
38AH044-084 Optional Single-Circuit Units and 38AH124,134
Modular Units (Dual-Circuit) — 60 Hz**

| UNIT 38AH | TOTAL LINEAR LENGTH OF INTERCONNECTING PIPE — FT | | | | | | | | | | | | | | |
|--|--|-------|-------|----------------------|-------|-------|-----------------------|-------|-------|------------------------|-------|-------|------------------------|-------|-------|
| | 15-50 (4.6-15.2) | | | 50-75 (15.2-22.9) | | | 75-100 (22.9-30.5) | | | 100-150 (30.5-45.7) | | | 150-200 (45.7-61.0) | | |
| | A | B | C | A | B | C | A | B | C | A | B | C | A | B | C |
| 044 | — | — | — | — | — | — | 1 5/8 | 2 1/8 | 2 5/8 | 1 5/8 | 2 1/8 | 2 5/8 | 1 5/8 | 2 5/8 | 3 1/8 |
| 054 | — | — | — | — | — | — | — | — | — | 1 5/8 | 2 5/8 | 3 1/8 | 1 5/8 | 2 5/8 | 3 1/8 |
| 064 Modules 124A, 124B,134A | 1 5/8 | 2 1/8 | 2 5/8 | 1 5/8 | 2 1/8 | 2 5/8 | 1 5/8 | 2 5/8 | 3 1/8 | 1 5/8 | 2 5/8 | 3 1/8 | 1 5/8 | 2 5/8 | 3 1/8 |
| 074; Module 134B | 1 5/8 | 2 1/8 | 2 5/8 | 1 5/8 | 2 5/8 | 3 1/8 | 1 5/8 | 2 5/8 | 3 1/8 | 1 5/8 | 2 5/8 | 3 1/8 | 2 1/8 | 3 1/8 | 3 5/8 |
| 084 | 1 5/8 | 2 1/8 | 2 5/8 | 1 5/8 | 2 5/8 | 3 1/8 | 1 5/8 | 2 5/8 | 3 1/8 | 2 1/8 | 3 1/8 | 3 5/8 | 2 1/8 | 3 1/8 | 3 5/8 |

LEGEND

- — Not Required
Pipe A — Suction Riser Without Trap
Pipe B — Suction Riser With Trap
Pipe C — Suction Line to Condensing Unit

NOTES:

1. See Refrigerant Piping Requirements table at top of page to determine need for double suction risers.
2. Pipe sizes are based on the total linear length, shown for each column, plus a 50% allowance for fittings.

3. Suction and liquid line sizing is based on pressure drop equivalent to 2 F (1.1 C) at nominal rating conditions. Higher design pressure drop criteria may allow selection of smaller pipe sizes but at a penalty of decreased system capacity and efficiency.

4. Refer to Carrier System Design Manual or to E20-II design programs for further information on selecting pipe sizes for split systems.
5. All pipe sizes are OD inches. See Table 8A notes for metric equivalents.
6. Refer to Fig. 13 for double suction riser construction.

**Table 9A — Refrigerant Piping Requirements for 38AH044-084
Optional Single-Circuit Units and 38AH124,134
Modular Units (Dual Circuit) — 50 Hz**

| UNIT 38AH | TOTAL LINEAR LENGTH OF INTERCONNECTING PIPE — FT (M) | | | | | | | | | | | |
|--|--|-------|---------------------|--------|----------------------|--------|-----------------------|--------|------------------------|--------|------------------------|--------|
| | 15-20 (4.6-6.1) | | 20-50 (6.1-15.2) | | 50-75 (15.2-22.9) | | 75-100 (22.9-30.5) | | 100-150 (30.5-45.7) | | 150-200 (45.7-61.0) | |
| | L | S | L | S | L | S | L | S | L | S | L | S |
| 044 | 7/8 | 2 1/8 | 7/8 | 2 1/8 | 1 1/8 | 2 1/8 | 1 1/8 | 2 5/8* | 1 1/8 | 2 5/8* | 1 3/8 | 2 5/8* |
| 054 | 7/8 | 2 1/8 | 1 1/8 | 2 1/8 | 1 1/8 | 2 5/8* | 1 1/8 | 2 5/8* | 1 1/8 | 2 5/8* | 1 3/8 | 3 1/8* |
| 064; Modules 124A, 124B, 134A | 7/8 | 2 1/8 | 1 1/8 | 2 5/8† | 1 1/8 | 2 5/8† | 1 1/8 | 2 5/8† | 1 3/8 | 3 1/8* | 1 3/8 | 3 1/8* |
| 074; Module 134B | 7/8 | 2 1/8 | 1 1/8 | 2 5/8† | 1 1/8 | 2 5/8† | 1 3/8 | 3 1/8* | 1 3/8 | 3 1/8* | 1 3/8 | 3 1/8* |
| 084 | 1 1/8 | 2 1/8 | 1 1/8 | 2 5/8† | 1 3/8 | 3 1/8* | 1 3/8 | 3 1/8* | 1 3/8 | 3 1/8* | 1 5/8 | 3 5/8* |

LEGEND

- CV** — Constant Volume
L — Liquid Line
S — Suction Line
VAV — Variable Air Volume

*Double suction riser required on all units configurations if condensing unit is elevated above evaporator.

†Double suction riser required on units with factory installed VAV option or CV units with additional field installed unloader on circuit A1 (lead) compressor if condensing unit is elevated above evaporator.

NOTES:

1. Addition of field-installed unloaders on A2 (lag) compressor is not recommended.
2. Piping sizes are based on unit operation above 40 F (4.4 C) saturated suction temperature (SST). When operating below 40 F (4.4 C), refer to Carrier System Design Manual, E20-II® piping design program, or ASHRAE Handbook to select proper line sizes.
3. Pipe sizes are based on the total linear length shown for each column, plus a 50% allowance for fittings.
4. Suction and liquid line sizing is based on pressure drop equivalent to 2 F (1.1 C) at nominal rating conditions. Higher pressure drop

design criteria may allow selection of smaller pipe sizes, but at a penalty of decreased system capacity and efficiency.

5. Double suction risers may be required if condensing unit is elevated above the evaporator. See footnotes and double suction riser table below.
6. Refer to Carrier System Design Manual, E20-II design program, or ASHRAE Handbook for further information on selecting pipe sizes for split systems.
7. All pipe sizes are OD inches. Equivalent sizes in millimeters follow:

| in. | mm |
|-------|------|
| 7/8 | 22.2 |
| 1 1/8 | 28.6 |
| 1 3/8 | 34.9 |
| 1 5/8 | 41.3 |
| 2 1/8 | 54.0 |
| 2 5/8 | 66.7 |
| 3 1/8 | 79.4 |
| 3 5/8 | 92.1 |

**Table 9B — Refrigerant Piping Requirements for Double Suction Risers,
38AH044-084 Optional Single-Circuit Units and 38AH124,134
Modular Units (Dual Circuit) — 50 Hz**

| UNIT 38AH | TOTAL LINEAR LENGTH OF INTERCONNECTING PIPE — FT (M) | | | | | | | | | | | | | | | | | |
|--|--|---|---|---------------------|-------|-------|----------------------|-------|-------|-----------------------|-------|-------|------------------------|-------|-------|------------------------|-------|-------|
| | 15-20 (4.6-6.1) | | | 20-50 (6.1-15.2) | | | 50-75 (15.2-22.9) | | | 75-100 (22.9-30.5) | | | 100-150 (30.5-45.7) | | | 150-200 (45.7-61.0) | | |
| | A | B | C | A | B | C | A | B | C | A | B | C | A | B | C | A | B | C |
| 044 | — | — | — | — | — | — | — | — | — | 1 5/8 | 2 1/8 | 2 5/8 | 1 5/8 | 2 5/8 | 2 5/8 | 1 5/8 | 2 5/8 | 2 5/8 |
| 054 | — | — | — | — | — | — | 1 5/8 | 2 1/8 | 2 5/8 | 1 5/8 | 2 1/8 | 2 5/8 | 1 5/8 | 2 1/8 | 2 5/8 | 1 5/8 | 2 5/8 | 3 1/8 |
| 064; Modules 124A, 124B, 134A | — | — | — | 1 5/8 | 2 1/8 | 2 5/8 | 1 5/8 | 2 1/8 | 2 5/8 | 1 5/8 | 2 1/8 | 2 5/8 | 1 5/8 | 2 5/8 | 3 1/8 | 1 5/8 | 2 5/8 | 3 1/8 |
| 074; Module 134B | — | — | — | 1 5/8 | 2 1/8 | 2 5/8 | 1 5/8 | 2 1/8 | 2 5/8 | 1 5/8 | 2 5/8 | 3 1/8 | 1 5/8 | 2 5/8 | 3 1/8 | 1 5/8 | 3 1/8 | 3 5/8 |
| 084 | — | — | — | 1 5/8 | 2 1/8 | 2 5/8 | 1 5/8 | 2 5/8 | 3 1/8 | 1 5/8 | 2 5/8 | 3 1/8 | 1 5/8 | 2 5/8 | 3 1/8 | 1 5/8 | 3 1/8 | 3 5/8 |

LEGEND

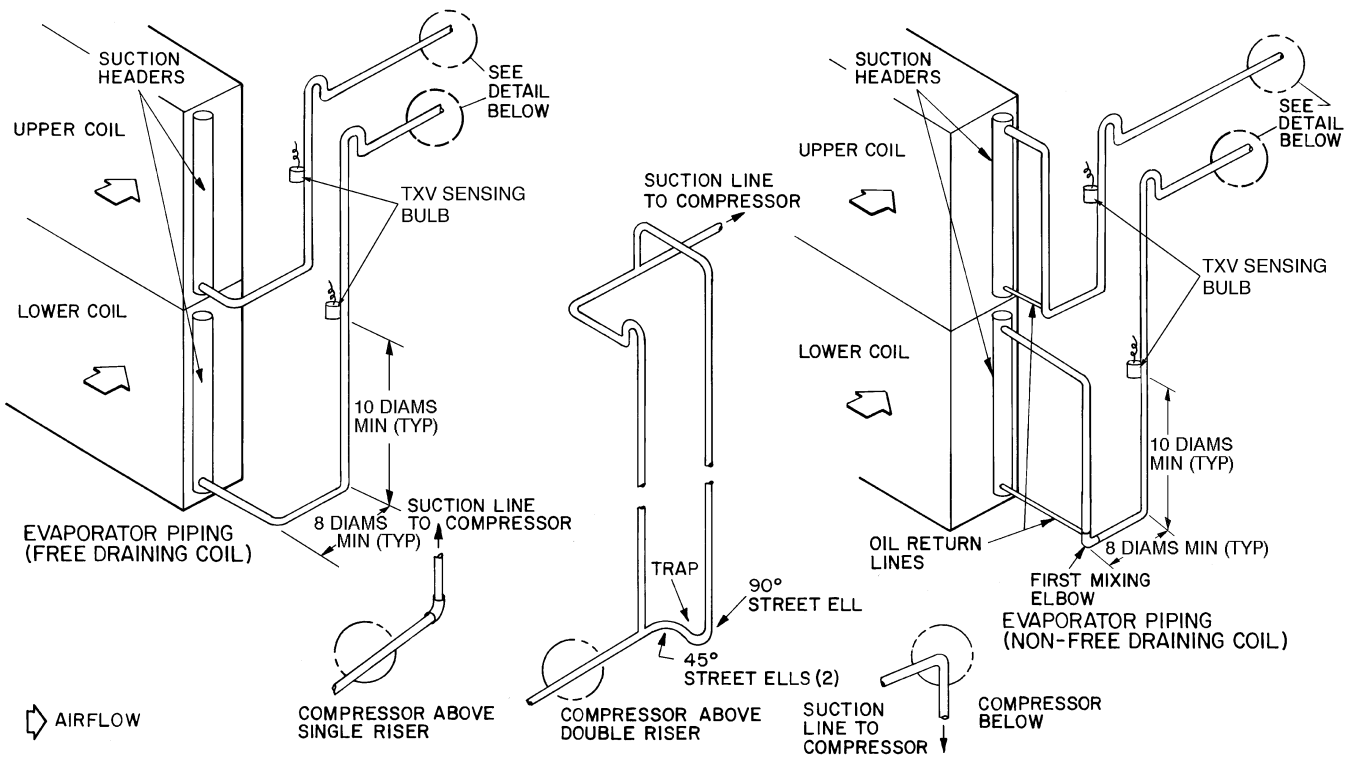
- — Not Required
Pipe A — Suction Riser Without Trap
Pipe B — Suction Riser With Trap
Pipe C — Suction Line to Condensing Unit

NOTES:

1. See Refrigerant Piping Requirements table at top of page to determine need for double suction risers.
2. Pipe sizes are based on the total linear length, shown for each column, plus a 50% allowance for fittings.

3. Suction and liquid line sizing is based on pressure drop equivalent to 2 F (1.1 C) at nominal rating conditions. Higher design pressure drop criteria may allow selection of smaller pipe sizes but at a penalty of decreased system capacity and efficiency.

4. Refer to Carrier System Design Manual or to E20-II design programs for further information on selecting pipe sizes for split systems.
5. All pipe sizes are OD inches. See Table 9A notes for metric equivalents.
6. Refer to Fig. 13 for double suction riser construction.



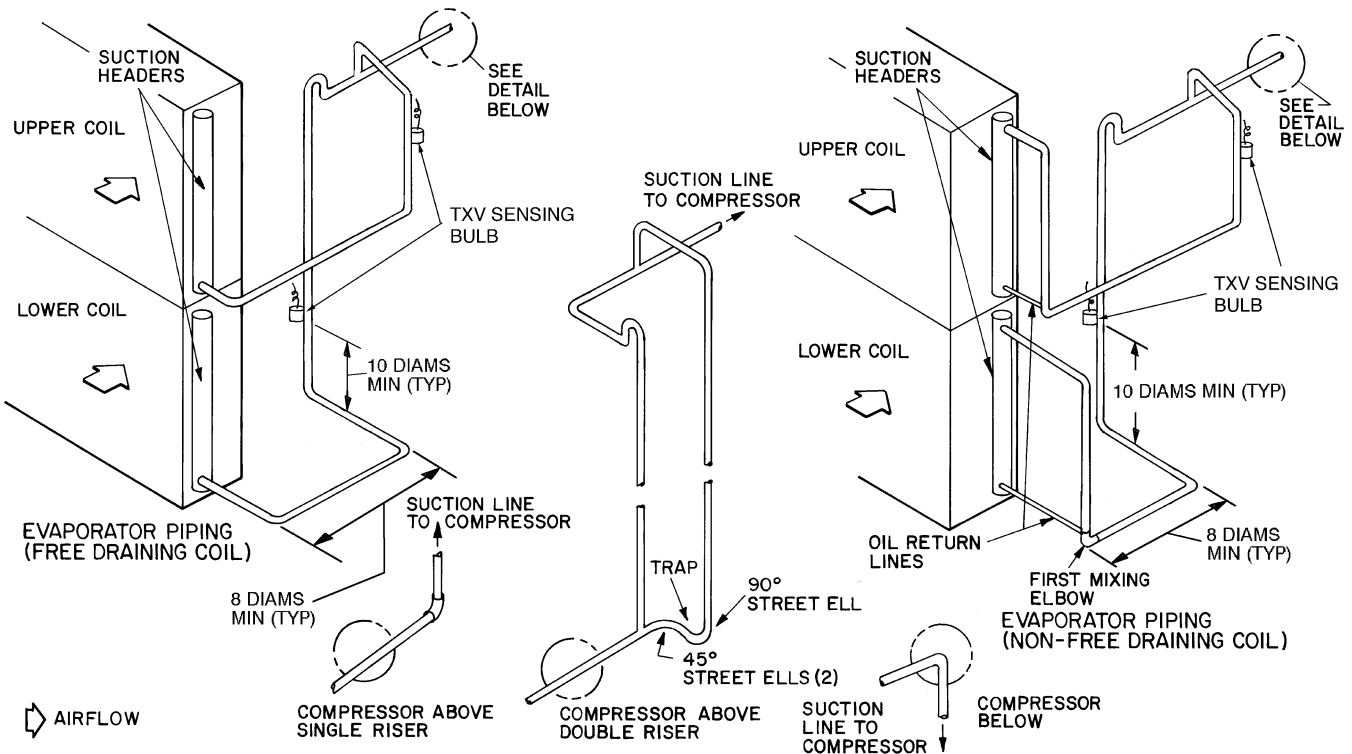
LEGEND

TXV — Thermostatic Expansion Valve

TYP — Typical

NOTE: Lower split first on, last off.

Fig. 14 — Typical Piping Connections for Face Split Coils for 38AH044-084 Dual-Circuit and 38AH094-134 Units



LEGEND

TXV — Thermostatic Expansion Valve

TYP — Typical

NOTE: Lower split first on, last off.

Fig. 15 — Typical Piping Connections for Face Split Coils for 38AH044-084 Optional Single-Circuit Units

Units 38AH124 and 134 Piping Kit Connections — The 38AH124 and 134 units are delivered with a factory-supplied suction and liquid piping kit for installation in the 24-in. (610-mm) service space between the 2 unit modules. The piping kit allows for a common unit side piping connection from the indoor unit to each of the condensing unit refrigeration circuits. Fittings are provided and shipped in the control box.

Remove the copper tubes from Module 124A or 134A compressor rails. Save the pipe clamps for later use. Cut the 2⁵/₈-in. (67-mm) suction tube into 2 pieces: 28 in. (711 mm) and 67 in. (1702 mm). Connect the 2 formed 1¹/₈-in. (29-mm) tubes to the liquid line connection at the liquid valve. See Fig. 16.

NOTE: Piping kit is designed to allow air handler connections to project from either side of the service space.

To prepare condensing unit modules for piping connection, refer to beginning paragraphs of Step 3 — Make Refrigeration Piping Connections, page 14.

Two 2⁵/₈-in. (67-mm) and one 1¹/₈-in. (29-mm) elbows are supplied for piping connections. Fit tubing to ensure proper installation. All tubes should have equal lengths projecting beyond unit corner posts. See Fig. 16. Ensure suction tube is level for oil return requirements.

▲ CAUTION

Protect liquid valves from the heat of brazing.

Braze the piping connections.

Level the tubes and clamp to the corner posts with factory-supplied self-drilling screws and pipe clamps removed from Module 124A or 134A during piping kit removal.

Units 38AH124 and 134 Sheet Metal Trim Kit Installation — After the units are in place and the piping kit is installed, install the sheet metal trim kit.

NOTE: Install sheet metal trim kit *before* connection to air handler tubing in case the modules must be repositioned to accommodate the sheet metal installation.

Remove two 43-in. (1092 mm) base rail trim pieces from Module 124A or 134A base rail. Remove the 3 corner post bolts from the bottom of each corner post at the service space. Align the base rail trim piece holes over the bolt holes in the corner rails. See Fig. 17. Reinsert corner post bolts through the trim piece into the corner posts.

Attach Top Cover — To attach top cover, proceed as follows:

For Unit 38AH124, remove screws A from top of each of 4 corner posts at service space. See Fig. 18. Place cover on top of service space and align top cover slots with corner post screw holes. Reinsert screws A.

For Unit 38AH134, remove screws A from top of each corner post on Module 134A and screws B from top of each corner post on Module 134B. See Fig. 18. Top cover is in 2 pieces: one vertical piece and one horizontal piece. Slide vertical top cover partly under Module 134B end cover flange;

align holes and reinsert screws B. Place horizontal cover on top of Module 134A end cover with opposite side resting on the horizontal flange of the installed Module B vertical top cover piece. Align holes on flange and top cover. Reinsert screws A through the top cover holes into the end cover. From within the service space, insert supplied screws up through the flange and horizontal cover to make a secure connection between the horizontal and vertical cover pieces.

Insert supplied screws into each of the 2 holes in the vertical side flange of the top cover at each end of the service space.

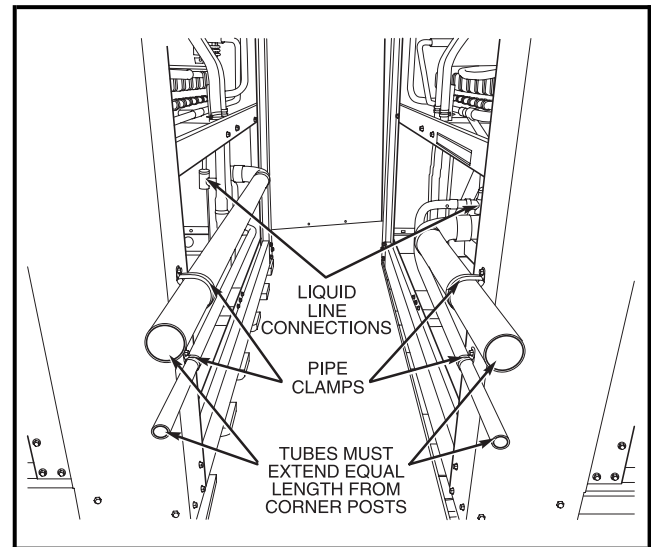
Attach Side Panels — Insert side panels at the ends of the service space and hook side panel flange over the 2 screws previously inserted in the top cover flange. Fasten panels to the corner posts with supplied self-drilling screws, 3 per side. See Fig. 19.

Connect Tubing from Evaporator to Unit

▲ CAUTION

Protect liquid valves from the heat of brazing.

Braze the liquid and suction lines from the evaporator to the condensing unit liquid and suction lines. Leak test the entire system by the pressure method described in the Carrier Standard Service Techniques Manual, Chapter 1, Section 1-6. Use R-22 at approximately 25 psig (172 kPa) backed up with an inert gas to a total pressure not to exceed 245 psig (1689 kPa). If a leak is detected, evacuate and dehydrate the system. Follow methods described in the Carrier Service Manual, Chapter 1, Section 1-7.



- NOTES:**
1. Ensure suction tube is level for oil return requirements.
 2. *Protect liquid valves from heat of brazing.*

Fig. 16 — Units 38AH124 and 134 with Installed Piping Kit

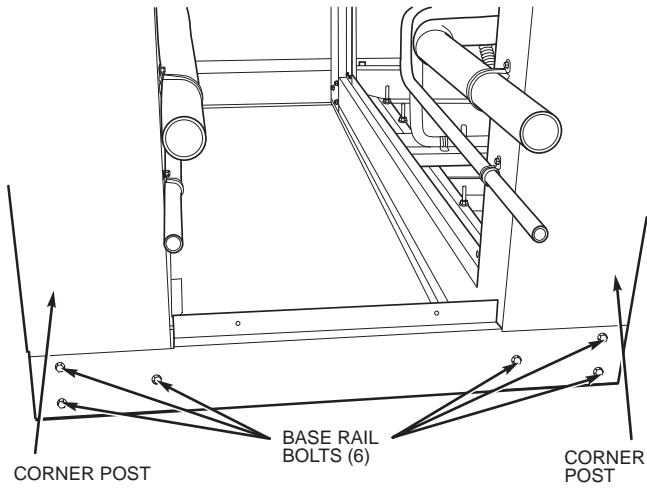


Fig. 17 — Units 38AH124 and 134 with Installed Trim Kit Rails

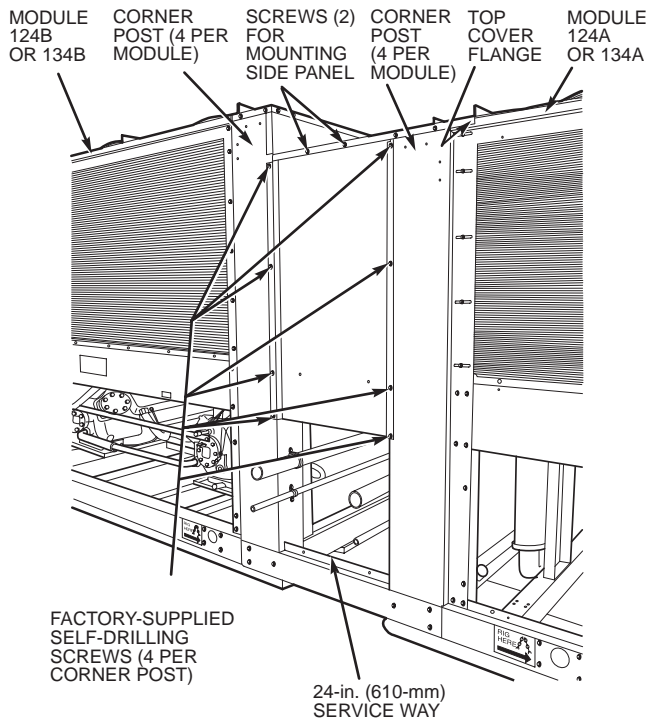


Fig. 19 — Fully Assembled Piping and Trim Kit (Unit 38AH134 Shown)

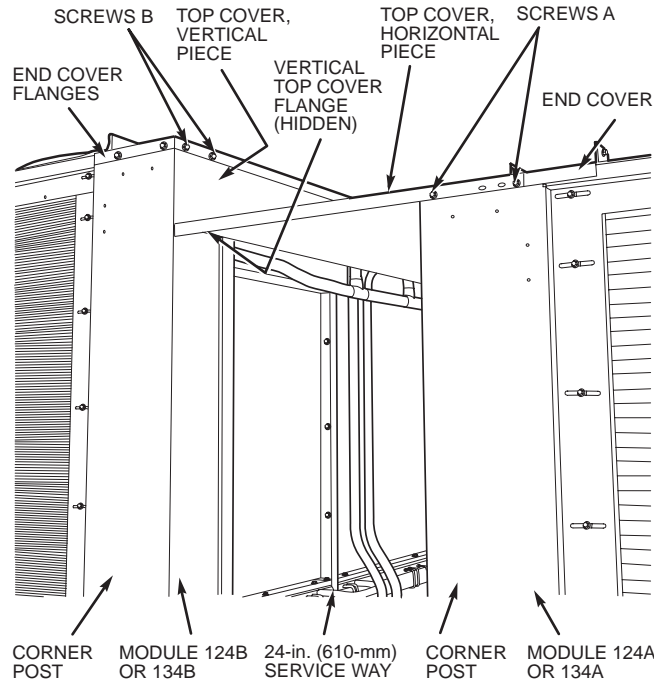


Fig. 18 — Units 38AH124 and 134 with Installed Top Cover (Unit 38AH134 Shown)

Step 4 — Make Electrical Connections

POWER SUPPLY — Electrical characteristics of available power supply must agree with unit nameplate rating. Supply voltage must be within the limits shown in Tables 10A or 10B, 11 and 12. See Table 13 for control circuit data and Table 14 for fan motor electrical data.

IMPORTANT: Operation of unit on improper supply voltage or with excessive phase imbalance constitutes abuse and can affect any Carrier warranty.

FIELD POWER CONNECTIONS — All power wiring must comply with applicable local and national codes. Install field-supplied, branch circuit safety disconnect(s) of a type that can be locked off/open. Disconnects must be located within sight of, and readily accessible from, the unit in compliance with NEC (National Electrical Code) (U.S.A. Standard) Article 440-14.

All field power enters the unit through a hole in the control box shelf. Refer to Fig. 20-28 for field wiring details.

MAIN POWER — Units 38AH044-104 have single-point power connection to simplify field-power wiring (all power enters at one end). Units 38AH124 and 134 require 2 connection points, one for each module. Units may use copper, copper-clad aluminum, or aluminum conductors at all voltages. The maximum wire size units can accept per terminal block is 500 kcmil.

Power must be supplied as shown in Table 15.

CONTROL CIRCUIT WIRING — Control circuit wiring is accomplished with a step-down transformer on voltage designations 500, 600, and 100 in table below where the primary voltage is field voltage. For 208/230-v, 3-ph, 60-Hz units, ensure that the transformer primary is wired properly for the voltage which will be applied. All control wiring must comply with applicable local and national codes. The safety circuits are 24 v on all units. The safety circuit voltage is created with a step-down transformer where main control voltage is the transformer primary voltage.

See Table 13 for control circuit information.

Table 10A — Electrical Data — 50/60 Hz (38AH044-084 Dual-Circuit Units)

| 38AH | Voltage Designation | Compressor A1/B1 Model No. | STANDARD UNIT | | | | | | COMPRESSOR* | | | |
|----------|---------------------|----------------------------|-------------------|-----------------|--------------|-------|-------|-------|-------------|-------|-------|-----|
| | | | Nameplate V-Ph-Hz | Supply Voltage† | | MCA | MOCPP | ICF | A1 | | B1 | |
| | | | | Min | Max | | | | RLA | LRA | RLA | LRA |
| 044 | 500 | 06E4250/250 | 208/230-3-60 | 187 | 254 | 179.4 | 225 | 434.7 | 67.9 | 345 | 67.9 | 345 |
| | 600 | | 460-3-60 | 414 | 508 | 91.3 | 100 | 218.6 | 34.6 | 173 | 34.6 | 173 |
| | 100 | | 575-3-60 | 518 | 632 | 78.4 | 100 | 162.4 | 28.8 | 120 | 28.8 | 120 |
| | 200 | | 380-3-60 | 342 | 418 | 93.5 | 125 | 241.2 | 34.6 | 191 | 34.6 | 191 |
| | 800 (PW) | | 230-3-50 | 198 | 254 | 180.2 | 225 | 296.7 | 67.9 | 207 | 67.9 | 207 |
| | 900 | | 380/415-3-50 | 342 | 440 | 91.5 | 100 | 219.6 | 34.6 | 173 | 34.6 | 173 |
| | 300 (PW) | | 346-3-50 | 325 | 367 | 100.0 | 125 | 165.9 | 33.3 | 115 | 33.3 | 115 |
| 054 | 500 | 06E4250/265 | 208/230-3-60 | 187 | 254 | 206.6 | 250 | 535.7 | 67.9 | 345 | 89.7 | 446 |
| | 600 | | 460-3-60 | 414 | 508 | 102.4 | 125 | 268.6 | 34.6 | 173 | 43.6 | 223 |
| | 100 | | 575-3-60 | 518 | 632 | 88.0 | 125 | 206.4 | 28.8 | 120 | 36.5 | 164 |
| | 200 | | 380-3-60 | 342 | 418 | 107.1 | 150 | 297.2 | 34.6 | 191 | 45.5 | 247 |
| | 900 | | 380/415-3-50 | 342 | 440 | 102.7 | 125 | 269.6 | 34.6 | 173 | 43.6 | 223 |
| | 300 (PW) | | 346-3-50 | 325 | 367 | 107.0 | 150 | 198.9 | 33.3 | 115 | 44.9 | 148 |
| | 064 | | 500 | 06E8265/275 | 208/230-3-60 | 187 | 254 | 249.3 | 350 | 617.5 | 89.7 | 446 |
| 600 | | 460-3-60 | 414 | | 508 | 115.5 | 150 | 307.6 | 43.6 | 223 | 46.8 | 253 |
| 100 | | 575-3-60 | 518 | | 632 | 100.6 | 125 | 226.1 | 36.5 | 164 | 40.4 | 176 |
| 200 | | 380-3-60 | 342 | | 418 | 126.9 | 175 | 341.1 | 45.5 | 247 | 52.6 | 280 |
| 900 | | 380/415-3-50 | 342 | | 440 | 114.1 | 150 | 335.6 | 43.6 | 223 | 46.8 | 280 |
| 300 (PW) | | 346-3-50 | 325 | | 367 | 129.8 | 175 | 230.5 | 44.9 | 148 | 53.8 | 168 |
| 074 | | 500 | 06E8275/299 | | 208/230-3-60 | 187 | 254 | 330.5 | 450 | 829.0 | 106.4 | 506 |
| | 600 | 460-3-60 | | 414 | 508 | 148.6 | 200 | 408.2 | 46.8 | 253 | 65.4 | 345 |
| | 100 | 575-3-60 | | 518 | 632 | 132.2 | 175 | 336.8 | 40.4 | 176 | 57.1 | 276 |
| | 200 | 380-3-60 | | 342 | 418 | 174.5 | 250 | 458.0 | 52.6 | 280 | 78.8 | 382 |
| | 900 | 380/415-3-50 | | 342 | 440 | 143.0 | 200 | 403.8 | 46.8 | 280 | 65.4 | 345 |
| | 300 (PW) | 346-3-50 | | 325 | 367 | 170.8 | 250 | 300.4 | 53.8 | 168 | 79.5 | 229 |
| | 084 | 500 | | 06E8299/299 | 208/230-3-60 | 187 | 254 | 371.5 | 500 | 870.0 | 147.4 | 690 |
| 600 | | 460-3-60 | 414 | | 508 | 167.2 | 225 | 426.8 | 65.4 | 345 | 65.4 | 345 |
| 100 | | 575-3-60 | 518 | | 632 | 148.9 | 200 | 353.5 | 57.1 | 276 | 57.1 | 276 |
| 200 | | 380-3-60 | 342 | | 418 | 200.7 | 250 | 484.2 | 78.8 | 382 | 78.8 | 382 |
| 900 | | 380/415-3-50 | 342 | | 440 | 167.6 | 225 | 428.4 | 65.4 | 345 | 65.4 | 345 |
| 300 (PW) | | 346-3-50 | 325 | | 367 | 205.3 | 250 | 334.9 | 79.5 | 229 | 79.5 | 229 |

See page 24 for Legend and Notes.

Table 10B — Electrical Data — 50/60 Hz (38AH044-084 Optional Single-Circuit Units)

| 38AH | Voltage Designation | Compressor A1/A2 Model No. | Nameplate V-Ph-Hz | Supply Voltage | | MCA | MOCP | ICF | COMPRESSOR* | | | |
|----------|---------------------|----------------------------|-------------------|----------------|--------------|-------|------|-------|-------------|-------|-------|-----|
| | | | | Min | Max | | | | A1 | | A2 | |
| | | | | | | | | | RLA | LRA | RLA | LRA |
| 044 | 500 | 06E4250/250 | 208/230-3-60 | 187 | 254 | 179.4 | 225 | 434.7 | 67.9 | 345 | 67.9 | 345 |
| | 600 | | 460-3-60 | 414 | 508 | 91.3 | 100 | 218.6 | 34.6 | 173 | 34.6 | 173 |
| | 100 | | 575-3-60 | 518 | 632 | 78.4 | 100 | 162.4 | 28.8 | 120 | 28.8 | 120 |
| | 200 | | 380-3-60 | 342 | 418 | 93.5 | 125 | 241.2 | 34.6 | 191 | 34.6 | 191 |
| | 800 (PW) | | 230-3-50 | 198 | 254 | 180.2 | 225 | 296.7 | 67.9 | 207 | 67.9 | 207 |
| | 900 | | 380/415-3-50 | 342 | 440 | 91.5 | 100 | 219.6 | 34.6 | 173 | 34.6 | 173 |
| | 300 (PW) | | 346-3-50 | 325 | 367 | 100.0 | 125 | 165.9 | 33.3 | 115 | 33.3 | 115 |
| 054 | 500 | 06E4265/250 | 208/230-3-60 | 187 | 254 | 206.6 | 250 | 535.7 | 89.7 | 446 | 67.9 | 345 |
| | 600 | | 460-3-60 | 414 | 508 | 102.4 | 125 | 268.6 | 43.6 | 223 | 34.6 | 173 |
| | 100 | | 575-3-60 | 518 | 632 | 88.0 | 125 | 206.4 | 36.5 | 164 | 28.8 | 120 |
| | 200 | | 380-3-60 | 342 | 418 | 107.1 | 150 | 297.2 | 45.5 | 247 | 34.6 | 191 |
| | 900 | | 380/415-3-50 | 342 | 440 | 102.7 | 125 | 269.6 | 43.6 | 223 | 34.6 | 173 |
| | 300 (PW) | | 346-3-50 | 325 | 367 | 107.0 | 150 | 198.9 | 44.9 | 148 | 33.3 | 115 |
| | 064 | | 500 | 06E8275/265 | 208/230-3-60 | 187 | 254 | 249.3 | 350 | 617.5 | 106.4 | 506 |
| 600 | | 460-3-60 | 414 | | 508 | 115.5 | 150 | 307.6 | 46.8 | 253 | 43.6 | 223 |
| 100 | | 575-3-60 | 518 | | 632 | 100.6 | 125 | 226.1 | 40.4 | 176 | 36.5 | 164 |
| 200 | | 380-3-60 | 342 | | 418 | 126.9 | 175 | 341.1 | 52.6 | 280 | 45.5 | 247 |
| 900 | | 380/415-3-50 | 342 | | 440 | 115.7 | 150 | 335.6 | 46.8 | 280 | 43.6 | 223 |
| 300 (PW) | | 346-3-50 | 325 | | 367 | 129.8 | 175 | 230.5 | 53.8 | 168 | 44.9 | 148 |
| 074 | | 500 | 06E8299/275 | | 208/230-3-60 | 187 | 254 | 330.5 | 450 | 829.0 | 147.4 | 690 |
| | 600 | 460-3-60 | | 414 | 508 | 148.6 | 200 | 408.2 | 65.4 | 345 | 46.8 | 253 |
| | 100 | 575-3-60 | | 518 | 632 | 132.2 | 175 | 336.8 | 57.1 | 276 | 40.4 | 176 |
| | 200 | 380-3-60 | | 342 | 418 | 174.5 | 250 | 458.0 | 78.8 | 382 | 52.6 | 280 |
| | 900 | 380/415-3-50 | | 342 | 440 | 143.0 | 200 | 403.8 | 65.4 | 345 | 46.8 | 280 |
| | 300 (PW) | 346-3-50 | | 325 | 367 | 170.8 | 250 | 300.4 | 79.5 | 229 | 53.8 | 168 |
| | 084 | 500 | | 06E8299/299 | 208/230-3-60 | 187 | 254 | 371.5 | 500 | 870.0 | 147.4 | 690 |
| 600 | | 460-3-60 | 414 | | 508 | 167.2 | 225 | 426.8 | 65.4 | 345 | 65.4 | 345 |
| 100 | | 575-3-60 | 518 | | 632 | 148.9 | 200 | 353.5 | 57.1 | 276 | 57.1 | 276 |
| 200 | | 380-3-60 | 342 | | 418 | 200.7 | 250 | 484.2 | 78.8 | 382 | 78.8 | 382 |
| 900 | | 380/415-3-50 | 342 | | 440 | 167.6 | 225 | 428.4 | 65.4 | 345 | 65.4 | 345 |
| 300 (PW) | | 346-3-50 | 325 | | 367 | 205.3 | 250 | 334.9 | 79.5 | 229 | 79.5 | 229 |

LEGEND

- FLA** — Full Load Amps
- ICF** — Maximum Instantaneous Current Flow During Starting.
(The point in the starting sequence where the sum of the LRA for the starting compressors, plus the total RLA for all running compressors, plus the FLA for all running fan motors is maximum.)
- kcmil** — Thousand Circular Mills
- LRA** — Locked Rotor Amps
- Max** — Maximum
- MCA** — Minimum Circuit Amps (used for sizing; complies with National Electrical Code [NEC] [U.S.A. Standard], section 430-24).
- Min** — Minimum
- MOCP** — Maximum Overcurrent Protection (used for sizing disconnect; complies with NEC Article 440, Section 22).
- RLA** — Rated Load Amps
- PW** — Part Wind Only

*All compressors are across-the-line start only except 38AH044 230 v, 3-phase, 50 Hz; and all 346 v, 3-phase, 50 Hz.

†Units are suitable for use on electrical systems where voltage supplied to unit terminals is within listed minimum to maximum limits.

NOTES:

1. Maximum allowable phase imbalance: voltage - 2%; amps - 10%.
2. Maximum incoming wire size for terminal block is 500 kcmil.

Table 11 — Electrical Data — 50/60 Hz (Units 38AH094,104)

| UNIT 38AH | VOLTAGE DESIGNATION | NAMEPLATE V-Ph-Hz | SUPPLY VOLTAGE* | | MCA | MOCP | ICF | COMPRESSOR† | | | | | | | |
|--------------|------------------------|----------------------|--------------------|-----|-------|------|-----|-------------|-----|------|-----|-------|-----|------|-----|
| | | | Min | Max | | | | A1 | | A2 | | B1 | | B2 | |
| | | | | | | | | RLA | LRA | RLA | LRA | RLA | LRA | RLA | LRA |
| 094 | 500 | 208/230-3-60 | 187 | 253 | 398.5 | 500 | 897 | 106.4 | 506 | 67.9 | 345 | 147.7 | 690 | — | — |
| | 600 | 460-3-60 | 414 | 506 | 183.1 | 225 | 443 | 46.8 | 253 | 34.6 | 173 | 65.4 | 345 | — | — |
| | 100 | 575-3-60 | 518 | 633 | 160.9 | 200 | 366 | 40.4 | 176 | 28.8 | 120 | 57.1 | 276 | — | — |
| | 200 | 380-3-60 | 342 | 418 | 209.1 | 250 | 493 | 52.6 | 280 | 34.6 | 191 | 78.8 | 382 | — | — |
| | 900 | 380/415-3-50 | 342 | 440 | 183.6 | 225 | 444 | 46.8 | 280 | 34.6 | 173 | 65.4 | 345 | — | — |
| | 300 (PW) | 346-3-50 | 325 | 380 | 212.9 | 250 | 343 | 53.8 | 168 | 33.3 | 115 | 79.5 | 229 | — | — |
| 104 | 500 | 208/230-3-60 | 187 | 253 | 399.4 | 450 | 722 | 89.7 | 446 | 67.9 | 345 | 89.7 | 446 | 89.7 | 446 |
| | 600 | 460-3-60 | 414 | 506 | 196.3 | 225 | 361 | 43.6 | 223 | 34.6 | 173 | 43.6 | 223 | 43.6 | 223 |
| | 100 | 575-3-60 | 518 | 633 | 168.0 | 200 | 286 | 36.5 | 164 | 28.8 | 120 | 36.5 | 164 | 36.5 | 164 |
| | 200 | 380-3-60 | 342 | 418 | 205.9 | 250 | 396 | 45.5 | 247 | 34.6 | 191 | 45.5 | 247 | 45.5 | 247 |
| | 900 | 380/415-3-50 | 342 | 440 | 196.7 | 225 | 363 | 43.6 | 223 | 34.6 | 173 | 43.6 | 223 | 43.6 | 223 |
| | 300 (PW) | 346-3-50 | 325 | 380 | 205.6 | 250 | 298 | 44.9 | 148 | 33.3 | 229 | 44.9 | 148 | 49.9 | 148 |

LEGEND

- Not Applicable
- FLA** — Full Load Amps
- ICF** — Maximum Instantaneous Current Flow During Starting. (The point in the starting sequence where the sum of the LRA for the starting compressors, plus the total RLA for all running compressors, plus the FLA for all running fan motors is maximum.)
- kcmil** — Thousand Circular Mils
- LRA** — Locked Rotor Amps
- MCA** — Minimum Circuit Amps (used for sizing; complies with National Electrical Code [NEC] [U.S.A. Standard], section 430-24).
- MOCP** — Maximum Overcurrent Protection (used for sizing disconnect; complies with NEC [U.S.A. Standard], section 440-22).
- RLA** — Rated Load Amps

*Units are suitable for use on electrical systems where voltage supplied to unit terminals is within listed minimum to maximum limits.
 †All compressors are across-the-line start only except 346-V, 3-ph, 50-Hz units.

NOTES:

1. Maximum allowable phase imbalance: voltage - 2%; amps - 10%.
2. Maximum incoming wire size for terminal block is 500 kcmil.
3. For units 38AH094 and 104 compressor model numbers, see table below:

| UNIT 38AH | 094 | | | 104 | | | | |
|----------------------|------|------|------|------|------|------|------|------|
| | CKT | A1 | A2 | B1 | A1 | A2 | B1 | B2 |
| MODEL NO. 06E | -275 | -250 | -299 | -265 | -250 | -265 | -265 | -265 |

Table 12 — Electrical Data — 50/60 Hz (Units 38AH124, 134)

| UNIT 38AH MODULE | VOLTAGE DESIGNATION | COMPRESSOR A1/A2 MODEL NO. | NAMEPLATE V-Ph-Hz | SUPPLY VOLTAGE* | | MCA | MOCP | ICF | COMPRESSOR† | | | |
|------------------------|------------------------|----------------------------------|----------------------|--------------------|-----|-------|------|-------|-------------|-----|-------|-----|
| | | | | Min | Max | | | | A1 | | A2 | |
| | | | | | | | | | RLA | LRA | RLA | LRA |
| 124A 124B 134A | 500 | 06E8275/ 265 | 208/230-3-60 | 187 | 254 | 249.3 | 350 | 617.5 | 106.4 | 506 | 89.7 | 446 |
| | 600 | | 460-3-60 | 414 | 508 | 115.5 | 150 | 307.6 | 46.8 | 253 | 43.6 | 223 |
| | 100 | | 575-3-60 | 518 | 632 | 100.6 | 125 | 226.1 | 40.4 | 176 | 36.5 | 164 |
| | 200 | | 380-3-60 | 342 | 418 | 126.9 | 175 | 341.1 | 52.6 | 280 | 45.5 | 247 |
| | 900 | | 380/415-3-50 | 342 | 440 | 115.7 | 150 | 335.6 | 46.8 | 280 | 43.6 | 223 |
| | 300 (PW) | | 346-3-50 | 325 | 367 | 129.8 | 175 | 230.5 | 53.8 | 168 | 44.9 | 148 |
| 134B | 500 | 06E8299/ 275 | 208/230-3-60 | 187 | 254 | 330.5 | 450 | 829.0 | 147.4 | 690 | 106.4 | 506 |
| | 600 | | 460-3-60 | 414 | 508 | 148.6 | 200 | 408.2 | 65.4 | 345 | 46.8 | 253 |
| | 100 | | 575-3-60 | 518 | 632 | 132.2 | 175 | 336.8 | 57.1 | 276 | 40.4 | 176 |
| | 200 | | 380-3-60 | 342 | 418 | 174.5 | 250 | 458.0 | 78.8 | 382 | 52.6 | 280 |
| | 900 | | 380/415-3-50 | 342 | 440 | 149.0 | 200 | 403.8 | 65.4 | 345 | 46.8 | 280 |
| | 300 (PW) | | 346-3-50 | 325 | 367 | 170.8 | 250 | 300.4 | 79.5 | 229 | 53.8 | 168 |

LEGEND

- FLA** — Full Load Amps
- ICF** — Maximum Instantaneous Current Flow During Starting. (The point in the starting sequence where the sum of the LRA for the starting compressors, plus the total RLA for all running compressors, plus the FLA for all running fan motors is maximum.)
- kcmil** — Thousand Circular Mils
- LRA** — Locked Rotor Amps
- MCA** — Minimum Circuit Amps (used for sizing; complies with National Electrical Code [NEC] [U.S.A. Standard], section 430-24).
- MOCP** — Maximum Overcurrent Protection (used for sizing disconnect; complies with NEC [U.S.A. Standard], section 440- 22).
- PW** — Part Wind
- RLA** — Rated Load Amps

*Units are suitable for use on electrical systems where voltage supplied to unit terminals is within listed minimum to maximum limits.
 †All compressors are across-the-line start only except 346-v, 3-ph, 50 Hz unit.

NOTES:

1. Maximum allowable phase imbalance: voltage - 2%; amps - 10%.
2. Maximum incoming wire size for terminal block is 500 kcmil.

Table 13 — Control Circuit Electrical Data — 50/60 Hz

| UNIT DESIGNATION | UNIT POWER V-Ph-Hz | CONTROL POWER | | | AMPS |
|---------------------|-----------------------|---------------|-----|-----|------|
| | | V-Ph-Hz | Min | Max | |
| -500 | 208/230-3-60 | 115-1-60 | 103 | 127 | 4.1 |
| -600 | 460-3-60 | 115-1-60 | 103 | 127 | 4.1 |
| -100 | 575-3-60 | 115-1-60 | 103 | 127 | 4.1 |
| -200 | 380-3-60 | 230-1-60 | 207 | 253 | 2.0 |
| -800 | 230-3-50 | 230-1-50 | 207 | 253 | 2.0 |
| -900 | 380/415-3-50 | 230-1-50 | 207 | 253 | 2.0 |
| -300 | 346-3-50 | 200-1-50 | 180 | 220 | 2.4 |

NOTE: Units 38AH124 and 134 have 2 control boxes per unit, one in each module.

Table 14 — Fan Motor Electrical Data

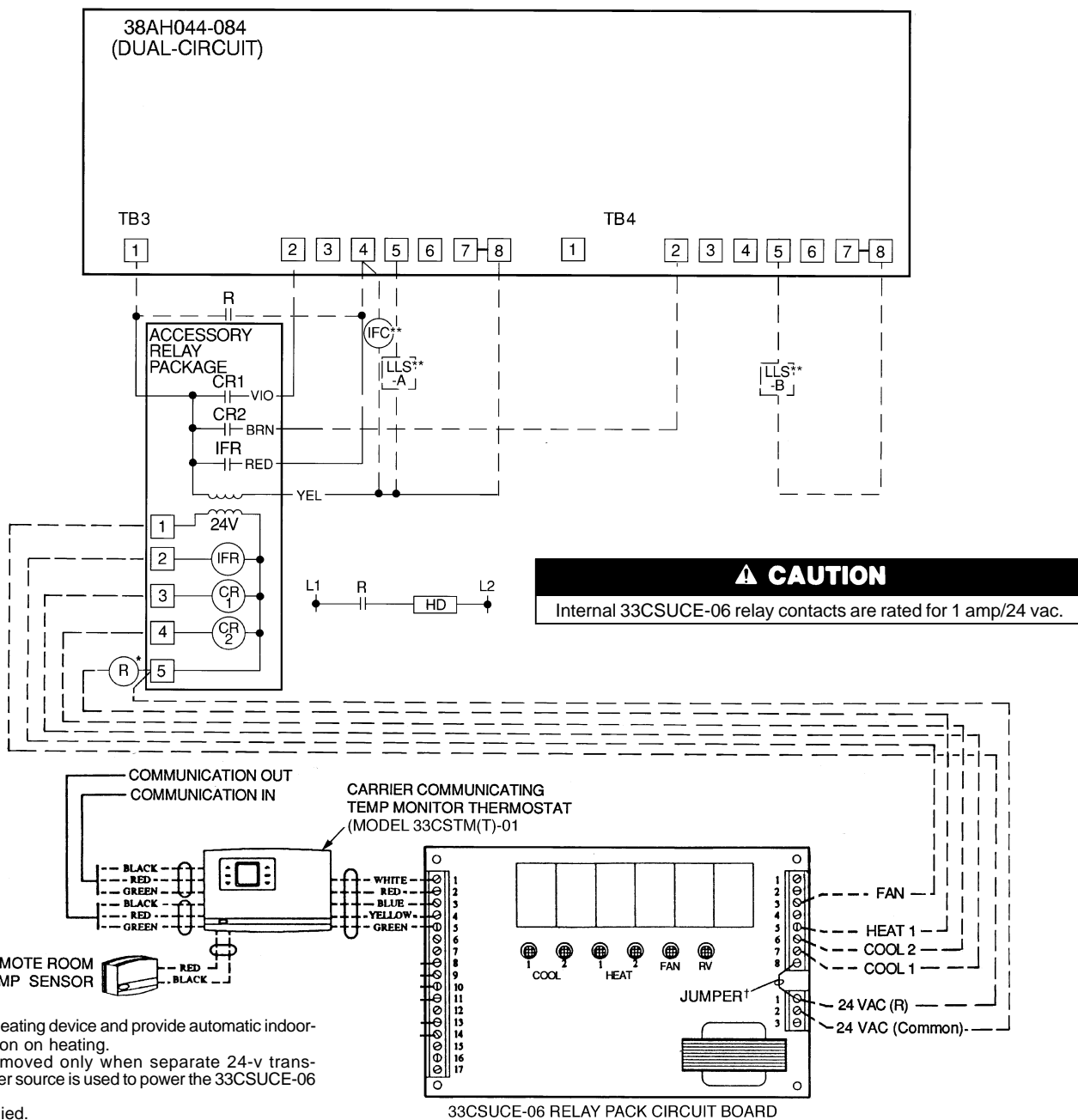
| UNIT 38AH | CONDENSER FAN | | | | | |
|-----------------------------|----------------------|-----|--------------|-------------|---------------------|-----------------------|
| | Nameplate V-Ph-Hz | Qty | Hp (kW) | Total kW | (No.*) FLA Each | (No.*) LRA Each |
| 044 | 208/230-3-60 | 4 | 1 (0.746) | 6.2 | (1,2) 5.5 (3,4) 6.6 | (1,2) 30.0 (3,4) 31.6 |
| | 460-3-60 | | | | (1,2) 2.8 (3,4) 3.3 | (1,2) 30.0 (3,4) 31.6 |
| | 575-3-60 | | | | (1-4) 3.4 | (1-4) 30.0 |
| | 380-3-60 | | | | (1-4) 3.9 | (1-4) 20.9 |
| | 230-3-50 | | | | (1,2) 5.5 (3,4) 6.8 | (1,2) 30.0 (3,4) 31.6 |
| | 380/415-3-50 | | | | (1-4) 3.4 | (1-4) 30.0 |
| | 346-3-50 | | | | (1-4) 4.4 | (1-4) 20.9 |
| 054 | 208/230-3-60 | 4 | 1 (0.746) | 6.2 | (1,2) 5.5 (3,4) 6.6 | (1,2) 30.0 (3,4) 31.6 |
| | 460-3-60 | | | | (1,2) 2.8 (3,4) 3.3 | (1,2) 30.0 (3,4) 31.6 |
| | 575-3-60 | | | | (1-4) 3.4 | (1-4) 30.0 |
| | 380-3-60 | | | | (1-4) 3.9 | (1-4) 20.9 |
| | 380/415-3-50 | | | | (1-4) 3.4 | (1-4) 30.0 |
| | 346-3-50 | | | | (1-4) 4.4 | (1-4) 20.9 |
| | | | | | | |
| 064 | 208/230-3-60 | 4 | 1 (0.746) | 6.2 | (1,2) 5.5 (3,4) 6.6 | (1,2) 30.0 (3,4) 31.6 |
| | 460-3-60 | | | | (1,2) 2.8 (3,4) 3.3 | (1,2) 30.0 (3,4) 31.6 |
| | 575-3-60 | | | | (1-4) 3.4 | (1-4) 30.0 |
| | 380-3-60 | | | | (1-4) 3.9 | (1-4) 20.9 |
| | 380/415-3-50 | | | | (1-4) 3.4 | (1-4) 30.0 |
| | 346-3-50 | | | | (1-4) 4.4 | (1-4) 20.9 |
| | | | | | | |
| 074 | 208/230-3-60 | 6 | 1 (0.746) | 9.3 | (1,2) 5.5 (3-6) 6.6 | (1,2) 30.0 (3-6) 31.6 |
| | 460-3-60 | | | | (1,2) 2.8 (3-6) 3.3 | (1,2) 30.0 (3-6) 31.6 |
| | 575-3-60 | | | | (1-6) 3.4 | (1-6) 30.0 |
| | 380-3-60 | | | | (1-6) 3.9 | (1-6) 20.9 |
| | 380/415-3-50 | | | | (1-6) 3.4 | (1-6) 30.0 |
| | 346-3-50 | | | | (1-6) 4.4 | (1-6) 20.9 |
| | | | | | | |
| 084 | 208/230-3-60 | 6 | 1 (0.746) | 9.3 | (1,2) 5.5 (3-6) 6.6 | (1,2) 30.0 (3-6) 31.6 |
| | 460-3-60 | | | | (1,2) 2.8 (3-6) 3.3 | (1,2) 30.0 (3-6) 31.6 |
| | 575-3-60 | | | | (1-6) 3.4 | (1-6) 30.0 |
| | 380-3-60 | | | | (1-6) 3.9 | (1-6) 20.9 |
| | 380/415-3-50 | | | | (1-6) 3.4 | (1-6) 30.0 |
| | 346-3-50 | | | | (1-6) 4.4 | (1-6) 20.9 |
| | | | | | | |
| 094 | 208/230-3-60 | 6 | 1 (0.746) | 9.4 | (1,2) 5.5 (3-6) 6.6 | (1,2) 30.0 (3-6) 31.6 |
| | 460-3-60 | | | | (1-2) 2.8 (3-6) 3.3 | (1,2) 30.0 (3-6) 31.6 |
| | 575-3-60 | | | | (1-6) 3.4 | (1-6) 30.0 |
| | 380-3-60 | | | | (1-6) 3.9 | (1-6) 20.9 |
| | 380/415-3-50 | | | | (1-6) 3.4 | (1-6) 30.0 |
| | 346-3-50 | | | | (1-6) 4.4 | (1-6) 20.9 |
| | | | | | | |
| 104 | 208/230-3-60 | 6 | 1 (0.746) | 9.5 | (1,2) 5.5 (3-6) 6.6 | (1,2) 30.0 (3-6) 31.6 |
| | 460-3-60 | | | | (1,2) 2.8 (3-6) 3.3 | (1,2) 30.0 (3-6) 31.6 |
| | 575-3-60 | | | | (1-6) 3.4 | (1-6) 30.0 |
| | 380-3-60 | | | | (1-6) 3.9 | (1-6) 20.9 |
| | 380/415-3-50 | | | | (1-6) 3.4 | (1-6) 30.0 |
| | 346-3-50 | | | | (1-6) 4.4 | (1-6) 20.9 |
| | | | | | | |
| UNIT 38AH MODULE | | | | | | |
| 124A 124B 134A | 208/230-3-60 | 4 | 1 (0.746) | 6.4 | (1,2) 5.5 (3,4) 6.6 | (1,2) 30.0 (3,4) 31.6 |
| | 460-3-60 | | | | (1,2) 2.8 (3,4) 3.3 | (1,2) 30.0 (3,4) 31.6 |
| | 575-3-60 | | | | (1-4) 3.4 | (1-4) 30.0 |
| | 380-3-60 | | | | (1-4) 3.9 | (1-4) 20.9 |
| | 380/415-3-50 | | | | (1-4) 3.4 | (1-4) 30.0 |
| | 346-3-50 | | | | (1-4) 4.4 | (1-4) 20.9 |
| 134B | 208/230-3-60 | 6 | 1 (0.746) | 9.2 | (1,2) 5.5 (3-6) 6.6 | (1,2) 30.0 (3-6) 31.6 |
| | 460-3-60 | | | | (1,2) 2.8 (3-6) 3.3 | (1,2) 30.0 (3-6) 31.6 |
| | 575-3-60 | | | | (1-6) 3.4 | (1-6) 30.0 |
| | 380-3-60 | | | | (1-6) 3.9 | (1-6) 20.9 |
| | 380/415-3-50 | | | | (1-6) 3.4 | (1-6) 30.0 |
| | 346-3-50 | | | | (1-6) 4.4 | (1-6) 20.9 |

LEGEND

FLA — Full Load Amps
LRA — Locked Rotor Amps

*Refers to condenser fans by position: See circled numbers on top views of units in Fig. 1-6.

NOTE: All fans are protected by a single circuit breaker.



*To control heating device and provide automatic indoor-fan operation on heating.
 †Jumper removed only when separate 24-v transformer power source is used to power the 33CSUCE-06 relay pack.
 **Field-supplied.

NOTES:

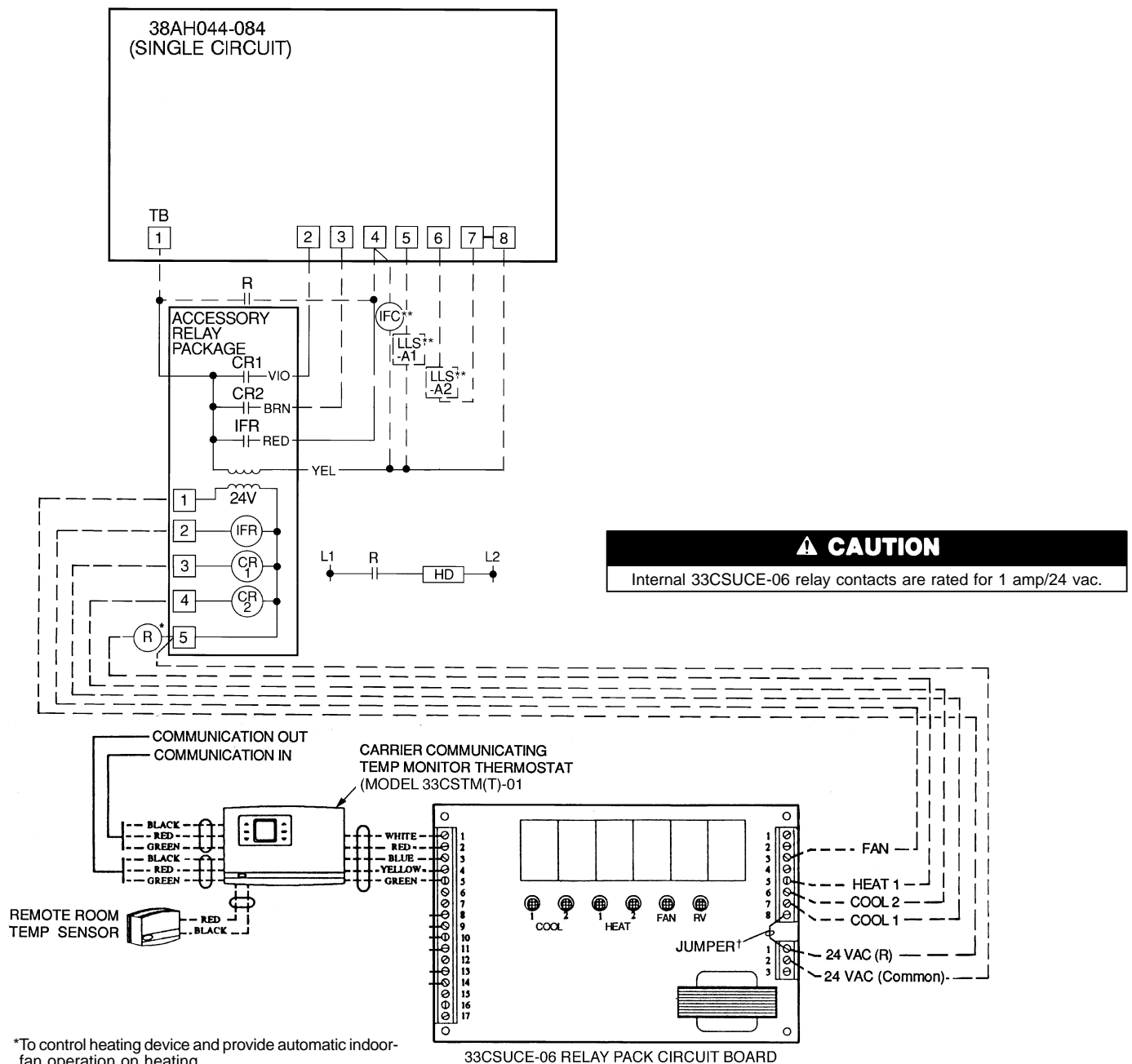
1. Liquid line solenoid valve LLS-A is used for solenoid drop on circuit A. Liquid line solenoid valve LLS-B is used for solenoid drop for circuit B.
2. Solenoid drop is a safety feature which prevents refrigerant migration to the compressor during the OFF cycle. It is recommended on all systems and required on systems where piping exceeds 75 ft (22.9 m) in length.
3. The 33CSUCE-06 relay pack requires 10 va.
4. Factory wiring is in accordance with NEC; field modifications or additions must be in compliance with all applicable codes.
5. Wiring for field power supply must be rated 75 C minimum. Use copper, copper-clad aluminum, or aluminum conductors. Maximum incoming wire size for each terminal block is 500 kcmil.
6. Terminal blocks TB3 and TB4 are for external field control connections. Control connections are to be Class 1 wiring.
7. Field-supplied components (IFC, LLS-A, and LLS-B) must have a maximum sealed coil rating of 30 va each (0.25 amp at 120 vac and

- 0.13 amp at 230 vac). Thermostats must have a minimum pilot duty rating of 300 va (2.5 amps at 120 vac and 1.3 amps at 230 vac).
8. Replacement of factory wires must be with type 105 C wire or its equivalent.
9. Field-supplied liquid line solenoid valves installed at the evaporator are required on all units.
10. Units have 175 va of power available for field-installed accessories.
11. To minimize voltage drop, the following wire sizes are recommended:

| LENGTH — Ft (M) | INSULATED WIRE — AWG (35 C Minimum) |
|------------------------|--|
| Up to 50 (15.2) | No. 18 |
| 50-75 (15.2-22.9) | No. 16 |
| More Than 75 (22.9) | No. 14 |

- LEGEND**
- AWG — American Wire Gage
 - CR — Control Relay
 - HD — Heating Device
 - IFC — Indoor-Fan Contactor
 - IFR — Indoor-Fan Relay
 - kcmil — Thousand Circular Mils
 - LLS — Liquid Line Solenoid
 - NEC — National Electrical Code (U.S.A. Standard)
 - R — Heating Relay (field-supplied 24-v sealed coil, 10 va maximum rating)
 - RV — Reversing Valve
 - TB — Terminal Block
 - — Factory Wiring
 - - - - Field Wiring

Fig. 20 — Field Wiring, One 2-Stage Thermostat — 38AH044-084 Dual-Circuit Units



CAUTION
Internal 33CSUCE-06 relay contacts are rated for 1 amp/24 vac.

*To control heating device and provide automatic indoor-fan operation on heating.

†Jumper removed only when separate 24-v transformer power source is used to power the 33CSUCE-06 relay pack.

**Field-supplied.

NOTES:

- Liquid line solenoid valves LLS-A1 and A2 are used for solenoid drops.
- Solenoid drop is a safety feature which prevents refrigerant migration to the compressor during the OFF cycle. It is recommended on all systems and required on systems where piping exceeds 75 ft (22.9 m) in length.
- The 33CSUCE-01 relay pack requires 10 va.
- Factory wiring is in accordance with NEC; field modifications or additions must be in compliance with all applicable codes.
- Wiring for field power supply must be rated 75 C minimum. Use copper, copper-clad aluminum, or aluminum conductors. Maximum incoming wire size for each terminal block is 500 kcmil.
- Terminal blocks are for external field control connections. Control connections are to be Class 1 wiring.
- Field-supplied components (IFC, LLS-A1, and LLS-A2) must have a maximum sealed coil rating of 30 va each (0.25 amp at 120 vac and 0.13 amp

- at 230 vac). Thermostats must have a minimum pilot duty rating of 300 va (2.5 amps at 120 vac and 1.3 amps at 230 vac).
- Replacement of factory wires must be with type 105 C wire or its equivalent.
- Field-supplied liquid line solenoid valves installed at the evaporator are required on all units.
- Units have 175 va of power available for field-installed accessories.
- To minimize voltage drop, the following wire sizes are recommended:

| LENGTH — Ft (M) | INSULATED WIRE — AWG (35 C Minimum) |
|---------------------|-------------------------------------|
| Up to 50 (15.2) | No. 18 |
| 50-75 (15.2-22.9) | No. 16 |
| More Than 75 (22.9) | No. 14 |

- LEGEND**
- AWG — American Wire Gage
 - CR — Control Relay
 - HD — Heating Device
 - IFC — Indoor-Fan Contactor
 - IFR — Indoor-Fan Relay
 - kcmil — Thousand Circular Mils
 - LLS — Liquid Line Solenoid
 - NEC — National Electrical Code (U.S.A. Standard)
 - R — Heating Relay (field-supplied 24-v sealed coil, 10 va maximum rating)
 - RV — Reversing Valve
 - TB — Terminal Block
 - Factory Wiring
 - - - Field Wiring

Fig. 21 — Field Wiring, One 2-Stage Thermostat — 38AH044-084 Optional Single-Circuit Units

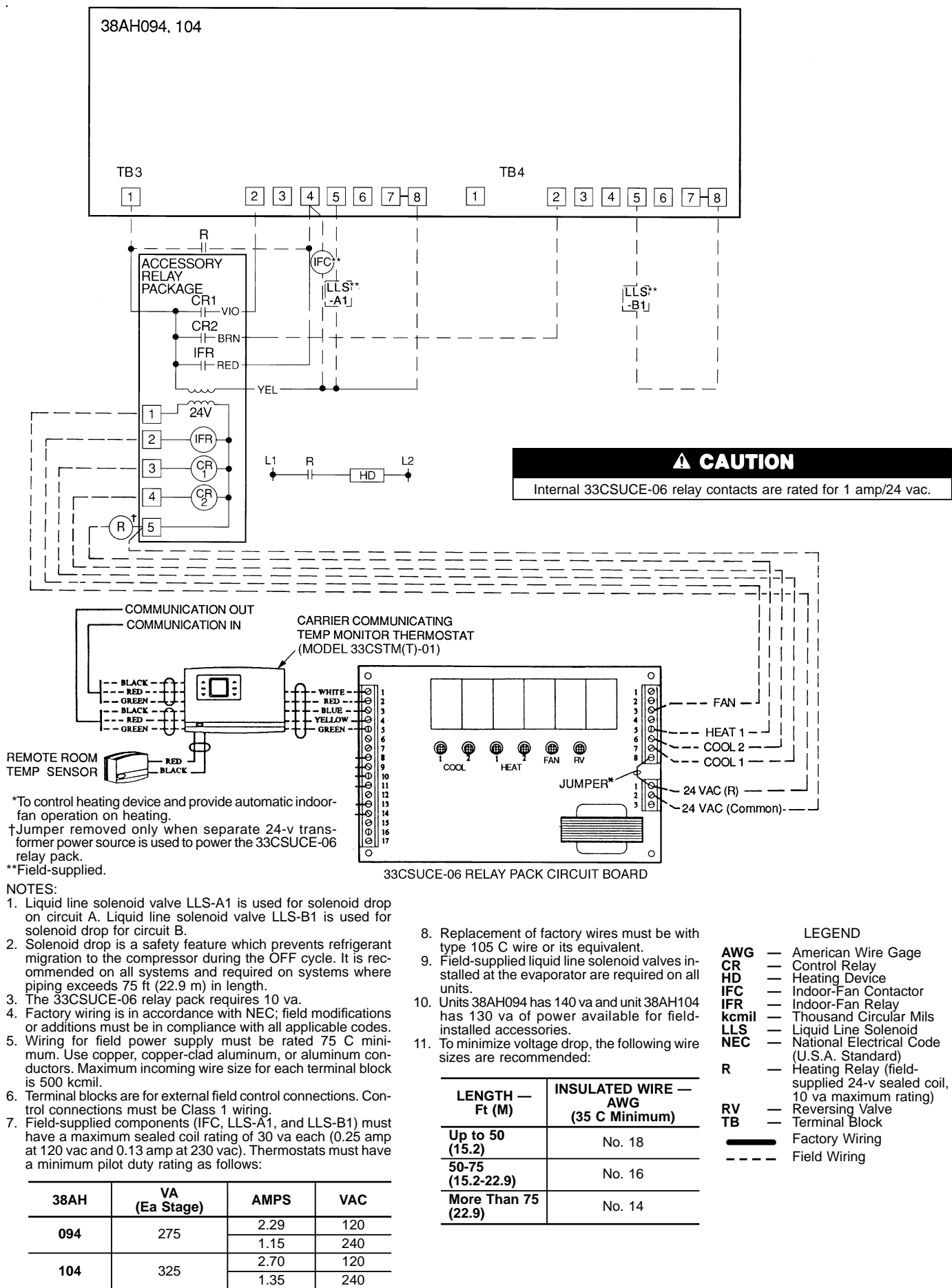
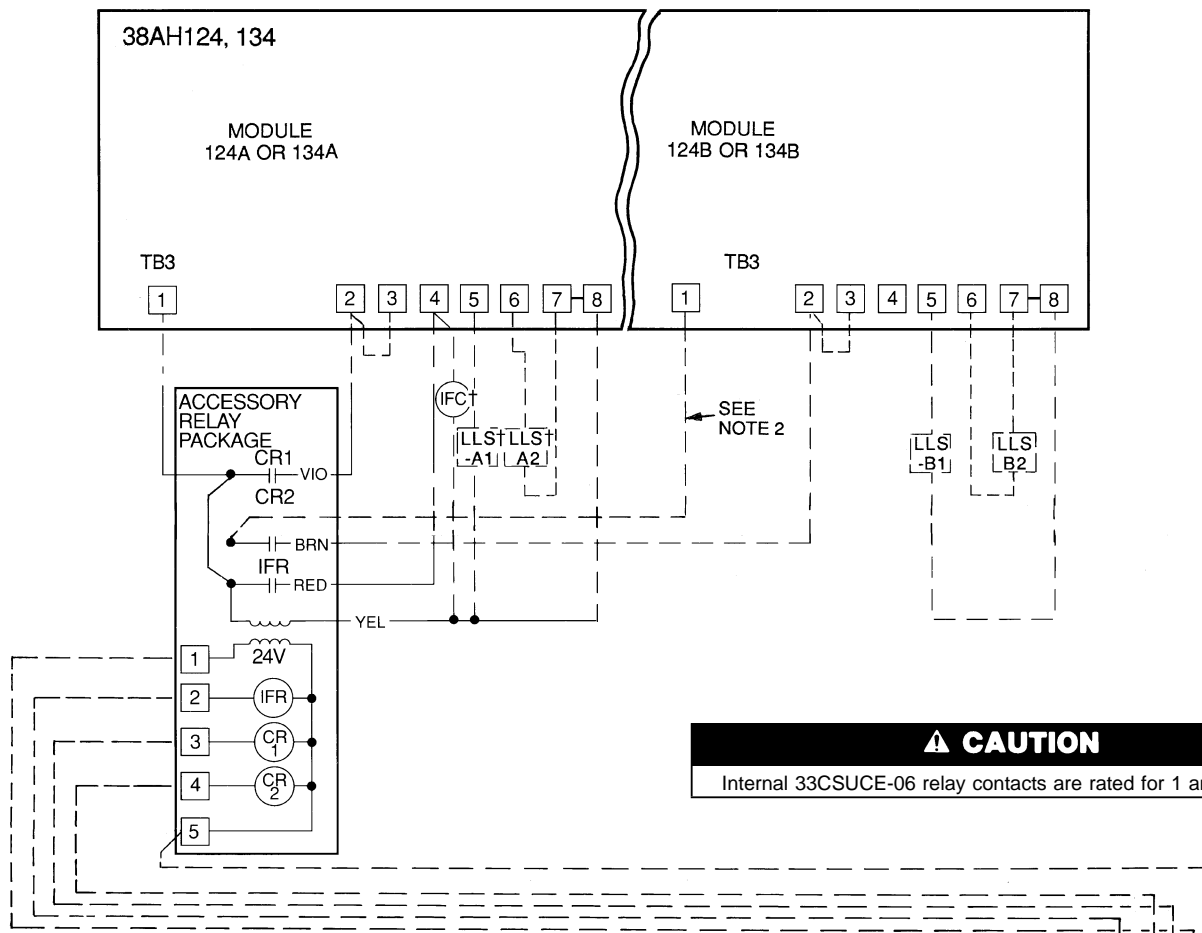
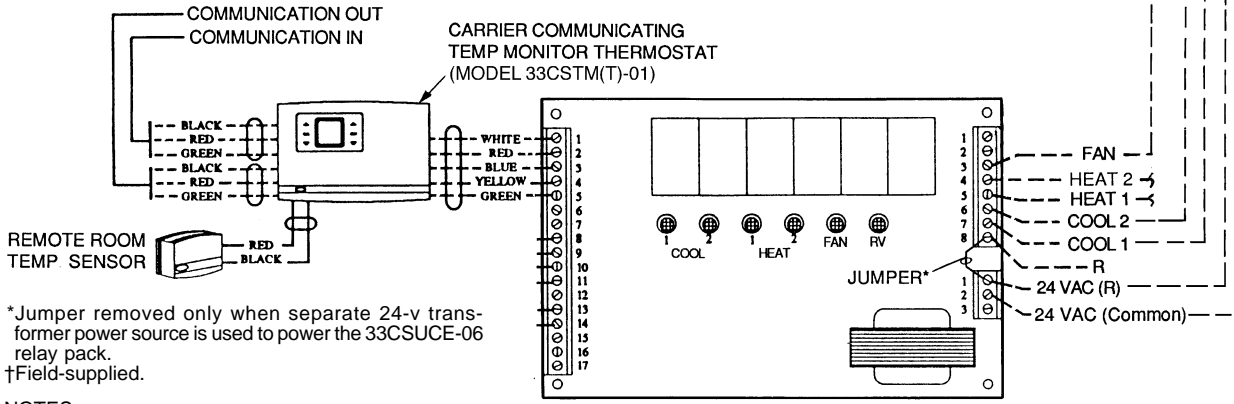


Fig. 22 — Field Wiring, One 2-Stage Thermostat — Units 38AH094 and 104



CAUTION
Internal 33CSUCE-06 relay contacts are rated for 1 amp/24 vac.



*Jumper removed only when separate 24-v transformer power source is used to power the 33CSUCE-06 relay pack.
†Field-supplied.

NOTES:

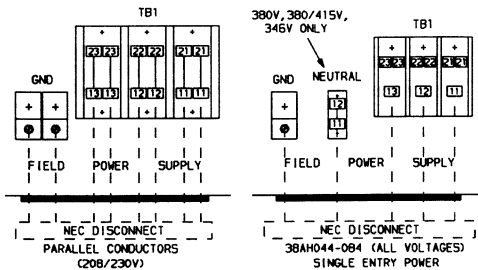
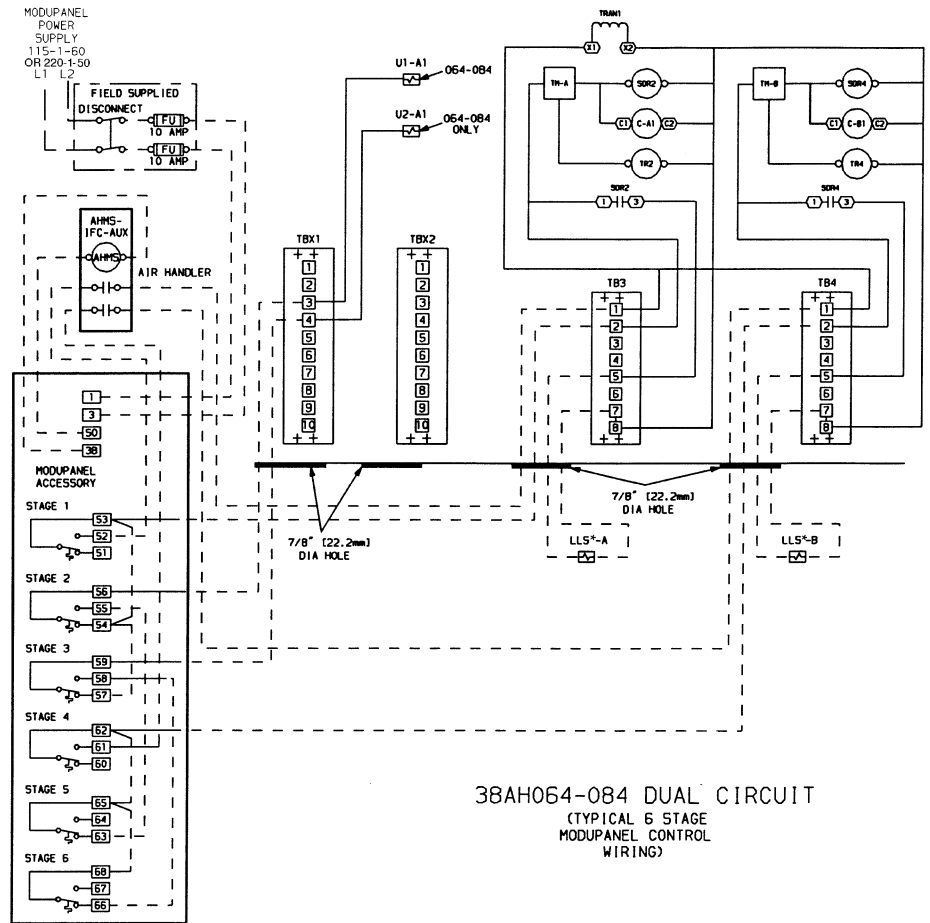
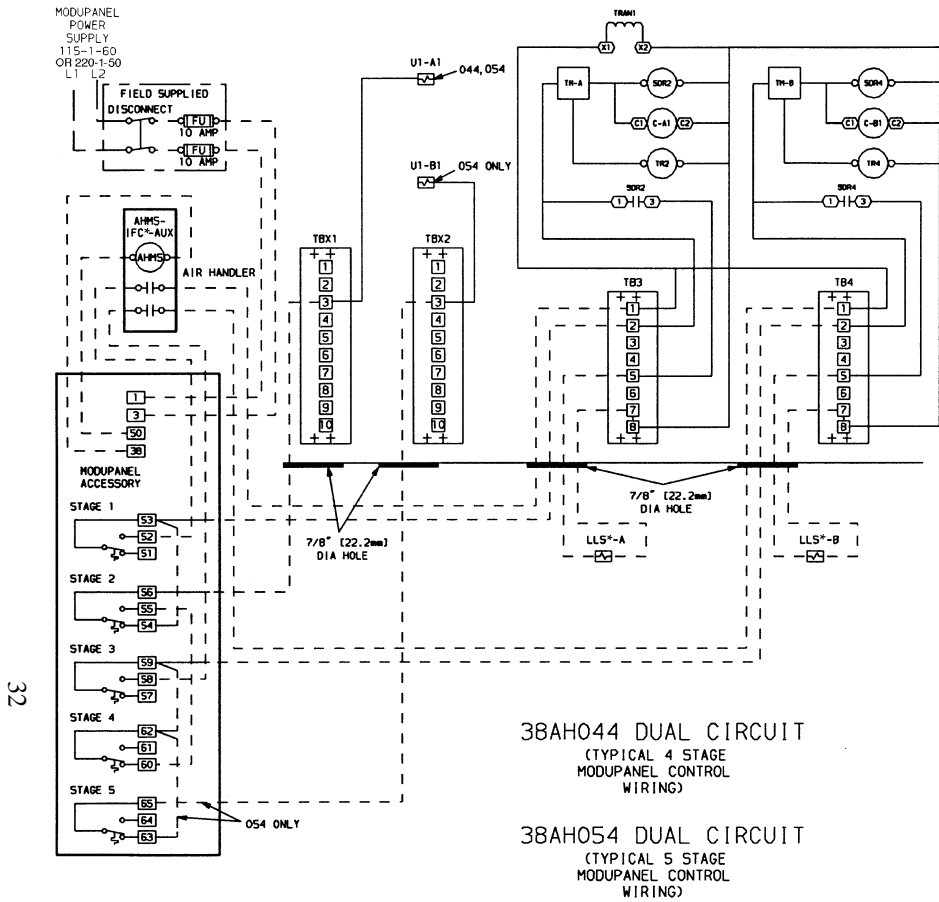
- Liquid line solenoid valves LLS-A1 and A2 are used for solenoid drop on Module 124A or 134A on circuit A. Liquid line solenoid valves LLS-B1 and B2 are used for solenoid drop for Module 124B or 134B. Solenoid drop is a safety feature which prevents refrigerant migration to the compressor during the OFF cycle. It is recommended on all systems and required on systems where piping exceeds 75 ft (22.9 m) in length.
- Disconnect black wire from CR2 terminal 6; cap loose end and secure. Connect new field-supplied wire from CR2 terminal 6 to TB3 terminal 1 on module 124B or 134B.
- The 33CSUCE-06 relay pack requires 10 va.
- Factory wiring is in accordance with NEC; field modifications or additions must be in compliance with all applicable codes.
- Wiring for field power supply must be rated 75 C minimum. Use copper, copper-clad aluminum, or aluminum conductors. Maximum incoming wire size for each terminal block is 500 kcmil.
- Terminal blocks (TB3) are for external field control connections. Control connections must be Class 1 wiring.

- Field-supplied components (IFC, LLS-A1,A2, and LLS-B1,B2) must have a maximum sealed coil rating of 30 va each (0.25 amp at 120 vac and 0.13 amp at 230 vac). Thermostats must have a minimum pilot duty rating of 300 va (2.5 amps at 120 vac).
- Replacement of factory wires must be with type 105 C wire or its equivalent.
- Field-supplied liquid line solenoid valves installed at the evaporator are required on all units.
- Units have 175 va of power available for field-installed accessories.
- To minimize voltage drop, the following wire sizes are recommended:

| LENGTH Ft (M) | INSULATED WIRE — AWG (35 C Minimum) |
|------------------------|--|
| Up to 50 (15.2) | No. 18 |
| 50-75 (15.2-22.9) | No. 16 |
| More Than 75 (22.9) | No. 14 |

- LEGEND**
- AWG — American Wire Gage
 - C — Compressor Contactor
 - CCPS — Capacity Control Pressure Switch
 - CR — Control Relay
 - HD — Heating Device
 - IFC — Indoor-Fan Contactor
 - IFR — Indoor-Fan Relay
 - kcmil — Thousand Circular Mils
 - LLS — Liquid Line Solenoid
 - NEC — National Electrical Code (U.S.A. Standard)
 - R — Heating Relay (field-supplied 24-v sealed coil, 10 va maximum rating)
 - RV — Reversing Valve
 - SDR — Solenoid Drop Relay
 - TB — Terminal Block
 - TR — Timer Relay
 - (Solid Line) — Factory Wiring
 - - - (Dashed Line) — Field Wiring

Fig. 23 — Field Wiring, One 2-Stage Thermostat — Units 38AH124 and 134



AHMS — Air Handler Motor Starter
AUX — Auxiliary
C — Compressor Contactor
FU — Fuse
GND — Equipment Ground
IFC — Indoor Fan Control
kcmil — Thousand Circular Mils
LLS — Liquid Line Solenoid
NEC — National Electrical Code (U.S.A. Standard)

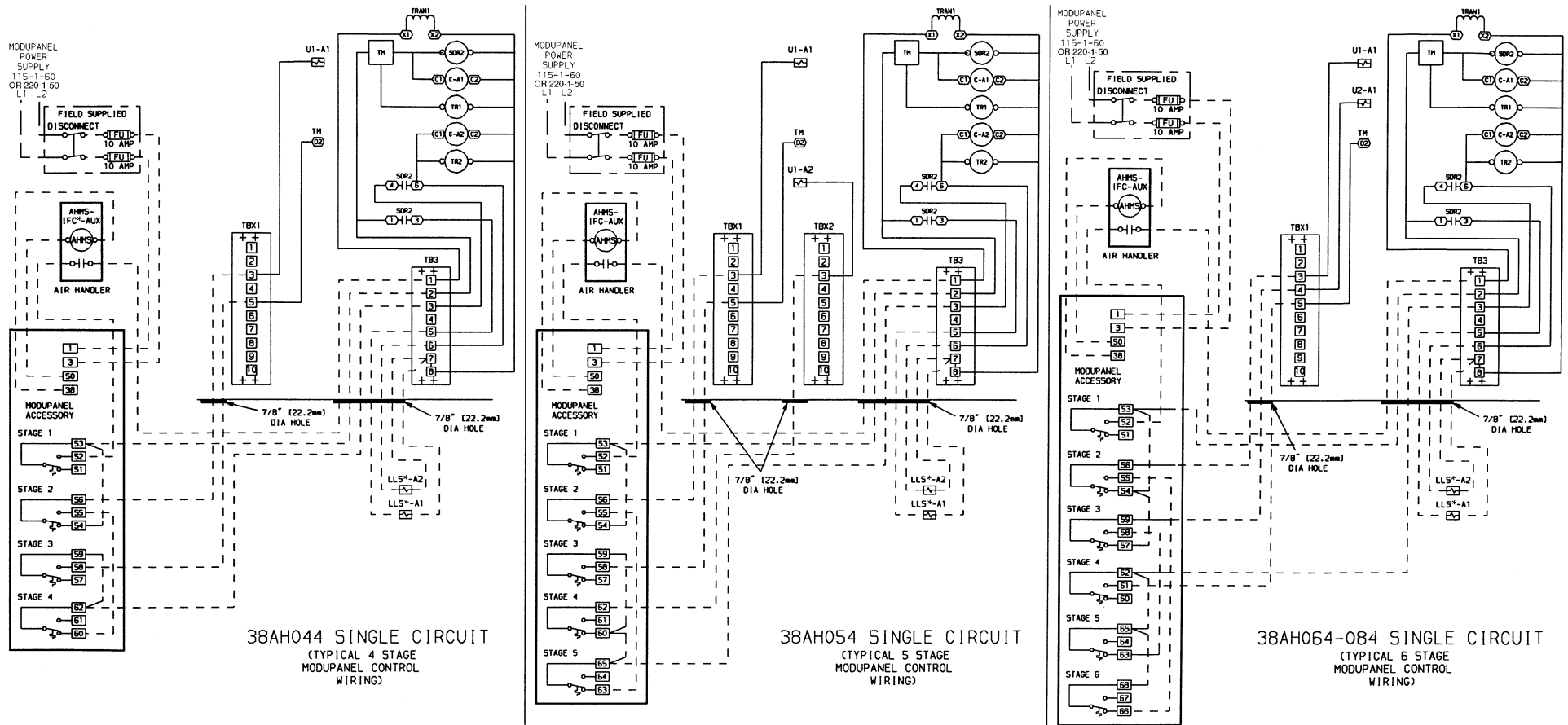
SDR — Solenoid Drop Relay
TB — Terminal Block
TBX — Terminal Block for Variable Air Volume Units
TM — Timer Motor
TR — Timer Relay
TRAN — Transformer
U — Unloader Solenoid
 ———— Factory Wiring
 - - - - - Field Wiring

*Field-supplied.

NOTES:

1. Factory wiring is in accordance with NEC; field modifications or additions must be in compliance with all applicable codes.
2. Wiring for field power supply must be rated 75 C minimum. Use copper, copper-clad aluminum, or aluminum conductors. Maximum incoming wire size for each terminal block is 500 kcmil.
3. Terminal blocks TB3 and TB4 are for external field control connections. Control connections are to be Class 1 wiring.
4. Field-supplied components (IFC, LLS-A, and LLS-B) must have a maximum sealed coil rating of 30 va each (.25 amp at 120 vac, .13 amp at 230 vac). AHMS IFC-AUX must have a minimum pilot duty rating of 200 va (1.7 amps at 120 vac, 0.9 amps at 230 vac) each.
5. Replacement of factory wires must be with type 105 C wire or its equivalent.
6. Field-supplied liquid line solenoid valves installed at the evaporator are required on all units.
7. Units have 175 va of power available for field-installed accessories.

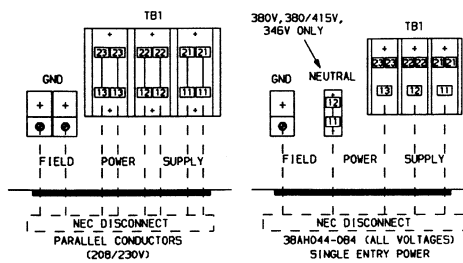
Fig. 24 — Field Wiring, Single ModuPanel™ Control, 38AH044-084 Dual-Circuit Units



38AH044 SINGLE CIRCUIT
(TYPICAL 4 STAGE
MODUPANEL CONTROL
WIRING)

38AH054 SINGLE CIRCUIT
(TYPICAL 5 STAGE
MODUPANEL CONTROL
WIRING)

38AH064-084 SINGLE CIRCUIT
(TYPICAL 6 STAGE
MODUPANEL CONTROL
WIRING)



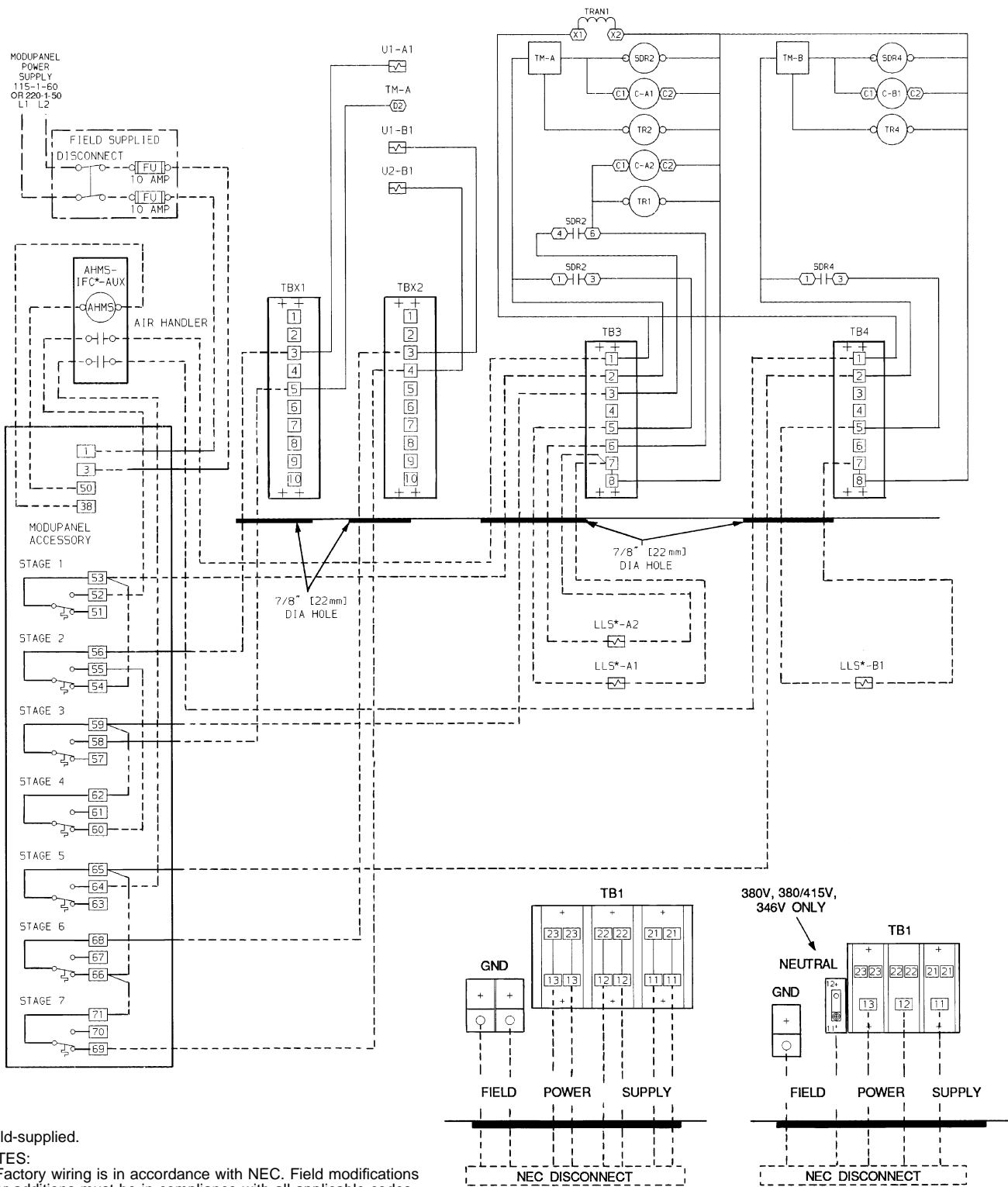
- LEGEND**
- AHMS** — Air Handler Motor Starter
 - AUX** — Auxiliary
 - C** — Compressor Contactor
 - FU** — Fuse
 - GND** — Equipment Ground
 - IFC** — Indoor Fan Control
 - kcmil** — Thousand Circular Mils
 - LLS** — Liquid Line Solenoid
 - NEC** — National Electrical Code (U.S.A. Standard)

- SDR** — Solenoid Drop Relay
 - TB** — Terminal Block
 - TBX** — Terminal Block for Variable Air Volume Units
 - TM** — Timer Motor
 - TR** — Timer Relay
 - TRAN** — Transformer
 - U** — Unloader Solenoid
- Factory Wiring
- - - Field Wiring

*Field-supplied.

- NOTES:**
- Factory wiring is in accordance with NEC; field modifications or additions must be in compliance with all applicable codes.
 - Wiring for field power supply must be rated 75 C minimum. Use copper, copper-clad aluminum, or aluminum conductors. Maximum in coming wire size for each terminal block is 500 kcmil.
 - Terminal blocks TB3, TBX1, and TBX2 are for external field control connections. Control connections are to be Class 1 wiring.
 - Field-supplied components (IFC, LLS-A1, and LLS-A2) must have a maximum sealed coil rating of 30 va each (0.25 amp at 120 vac, 13 amp at 230 vac). AHMS IFC-AUX must have minimum pilot duty rating of 400 va each (3.4 amps at 120 vac, 1.8 amps at 230 vac) each.
 - Replacement of factory wires must be with type 105 C wire or its equivalent.
 - Field-supplied liquid line solenoid valves installed at the evaporator are required on all units.
 - Control has 175 va of power available for field-installed accessories.

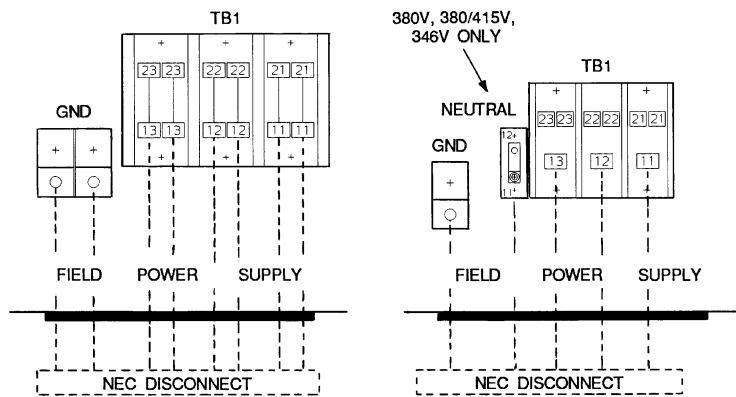
Fig. 25 — Field Wiring, Single ModuPanel™ Control, 38AH044-084 Optional Single-Circuit Units



*Field-supplied.

NOTES:

1. Factory wiring is in accordance with NEC. Field modifications or additions must be in compliance with all applicable codes.
2. Wiring for field power supply must be rated 75 C minimum. Use copper, copper-clad aluminum, or aluminum conductors. Maximum incoming wire size for each terminal block is 500 kcmil.
3. Terminal blocks TB3, TB4, TBX1, and TBX2 are for external field control connections. Control connections are to be Class 1 wiring.
4. Field-supplied components (IFC, LLS-A1, A2, B1, and B2) must have a maximum sealed coil rating of 30 va each (0.25 amp at 120 vac, 0.13 amp at 230 vac). AHMS IFC-AUX contact must have minimum pilot duty rating of 325 va each (2.7 amps at 120 vac, 1.4 amps at 230 vac).
5. Replacement of factory wires must be with type 105 C wire or its equivalent.
6. Field-supplied liquid line solenoid valves installed at the evaporator are required on all units.
7. Control has 25 va of power available for field-installed accessories.



(208/230V)
PARALLEL CONDUCTORS

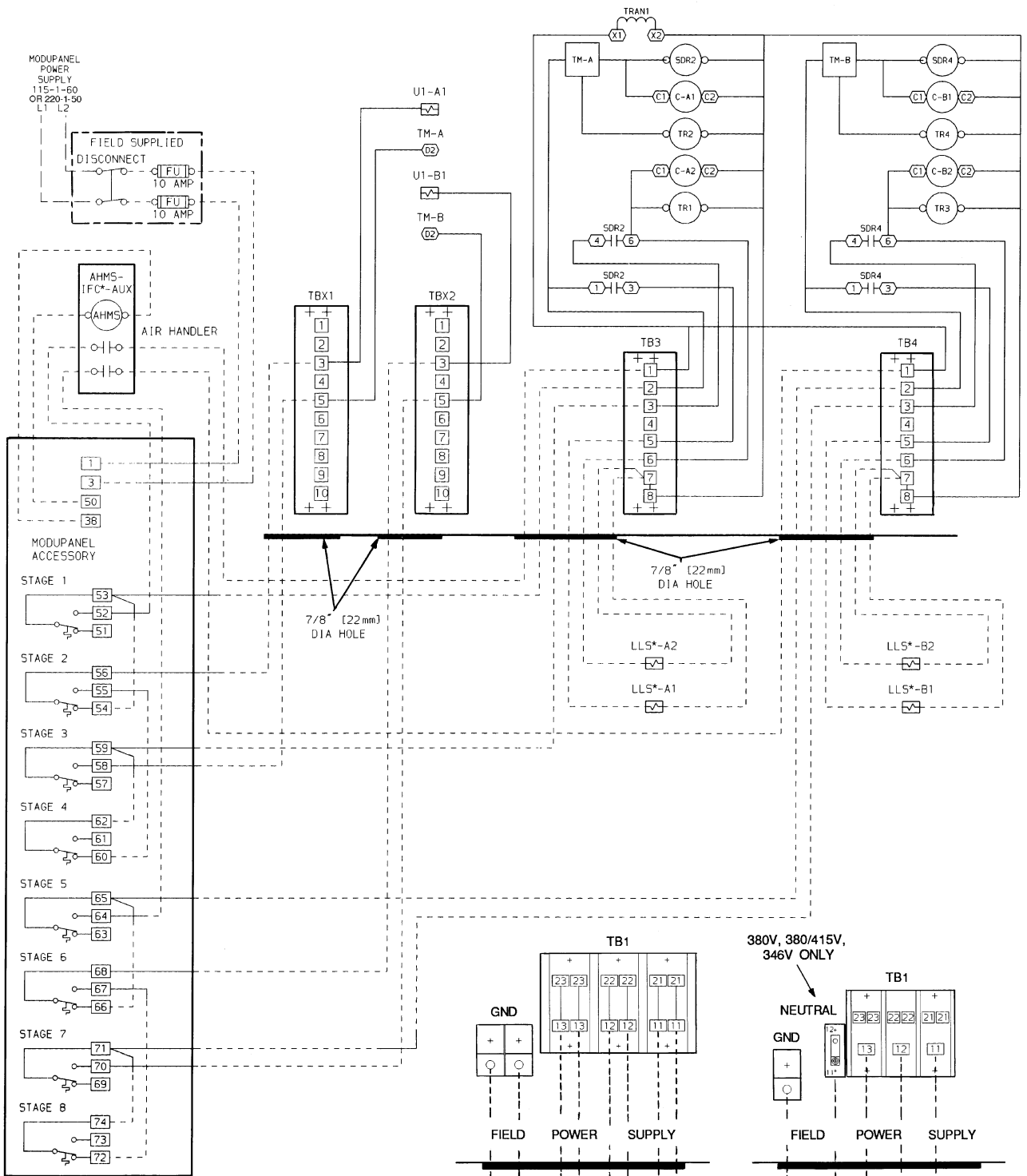
(ALL VOLTAGES)
SINGLE-ENTRY POWER

AHMS — Air Handler Motor Starter
AUX — Auxiliary
C — Compressor Contactor
FU — Fuse
GND — Equipment Ground
IFC — Indoor Fan Control
kcmil — Thousand Circular Mils
LLS — Liquid Line Solenoid
NEC — National Electrical Code (U.S.A. Standard)

LEGEND

SDR — Solenoid Drop Relay
TB — Terminal Block
TBX — Terminal Block for Variable Air Volume Units
TM — Timer Motor
TR — Timer Relay
TRAN — Transformer
U — Unloader Solenoid
 ——— Factory Wiring
 - - - Field Wiring

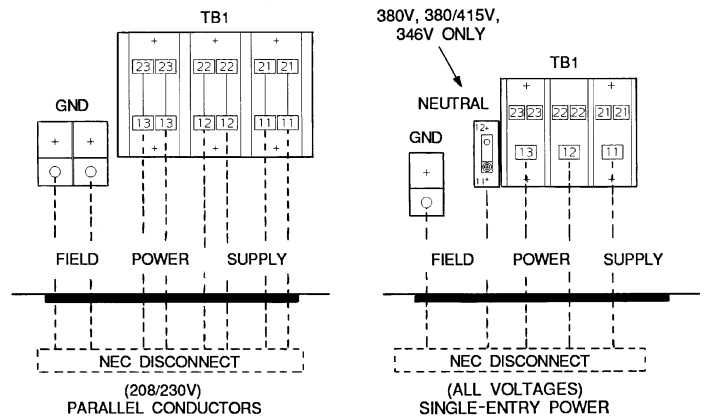
Fig. 26 — Field Wiring, Single ModuPanel™ Control, Unit 38AH094



*Field-supplied.

NOTES:

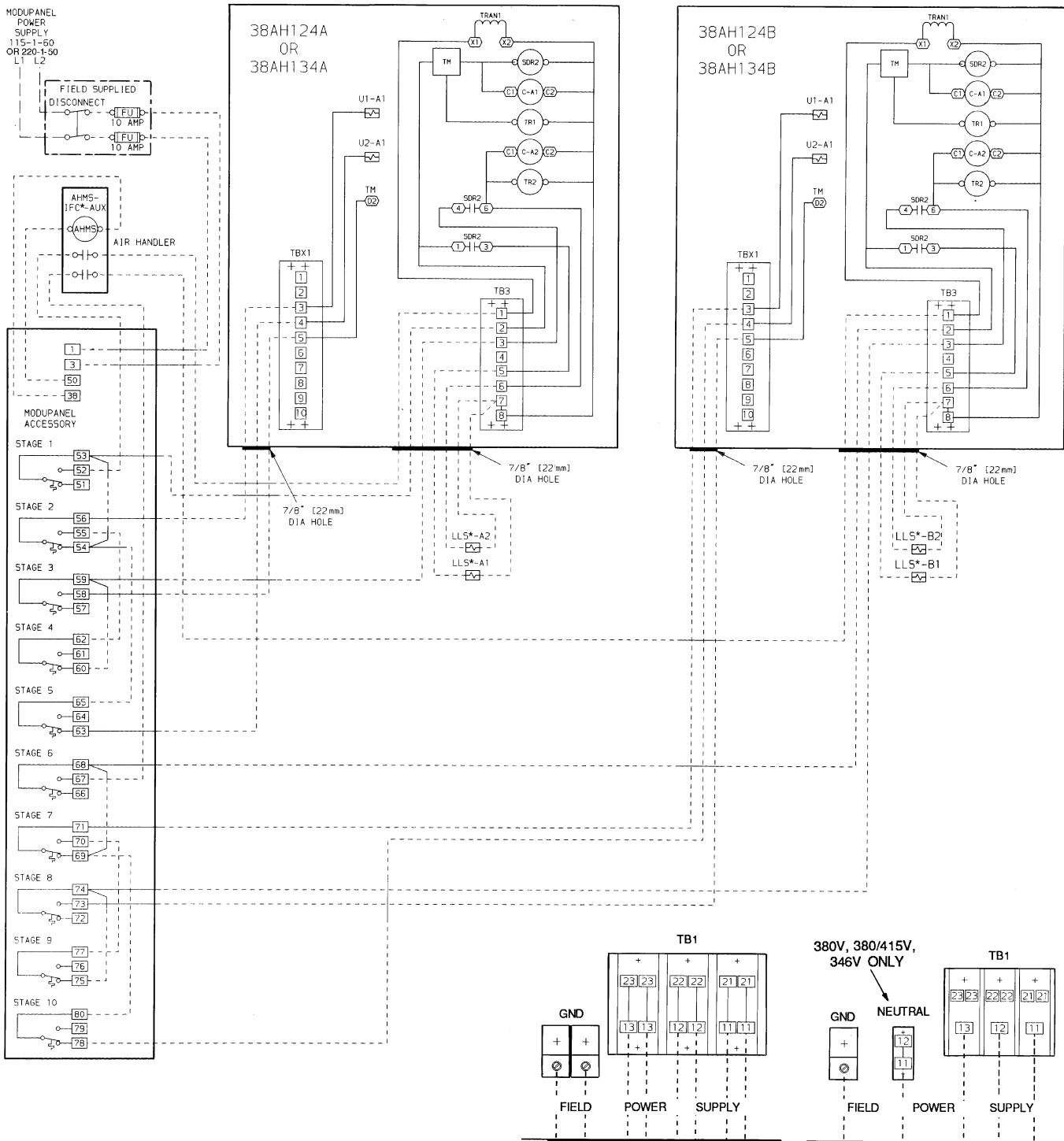
1. Factory wiring is in accordance with NEC. Field modifications or additions must be in compliance with all applicable codes.
2. Wiring for field power supply must be rated 75 C minimum. Use copper, copper-clad aluminum, or aluminum conductors. Maximum incoming wire size for each terminal block is 500 kcmil.
3. Terminal blocks TB3, TB4, TBX1, and TBX2 are for external field control connections. Control connections are to be Class 1 wiring.
4. Field-supplied components (IFC, LLS-A1, A2, B1, and B2) must have a maximum sealed coil rating of 30 va each (0.25 amp at 120 vac, 0.13 amp at 230 vac). AHMS IFC-AUX contact must have minimum pilot duty rating of 375 va each (3.1 amps at 120 vac, 1.6 amps at 230 vac).
5. Replacement of factory wires must be with type 105 C wire or its equivalent.
6. Field-supplied liquid line solenoid valves installed at the evaporator are required on all units.
7. Control has 35 va of power available for field-installed accessories.



LEGEND

- | | |
|---|---|
| AHMS — Air Handler Motor Starter | TB — Terminal Block |
| AUX — Auxiliary | TBX — Terminal Block for Variable Air Volume Units |
| C — Compressor Contactor | TM — Timer Motor |
| FU — Fuse | TR — Timer Relay |
| GND — Equipment Ground | TRAN — Transformer |
| IFC — Indoor Fan Control | U — Unloader Solenoid |
| kcmil — Thousand Circular Mills | — Factory Wiring |
| LLS — Liquid Line Solenoid | - - - Field Wiring |
| NEC — National Electrical Code (U.S.A. Standard) | |
| SDR — Solenoid Drop Relay | |

Fig. 27 — Field Wiring, Single ModuPanel™ Control, Unit 38AH104



*Field-supplied.

NOTES:

1. Factory wiring is in accordance with NEC. Field modifications or additions must be in compliance with all applicable codes.
2. Wiring for field power supply must be rated 75 C minimum. Use copper, copper-clad aluminum, or aluminum conductors. Maximum incoming wire size for each terminal block is 500 kcmil.
3. Terminal blocks TB3 and TBX1 are for external field control connections. Control connections are to be Class 1 wiring.
4. Field-supplied components (IFC, LLS-A1 and A2) must have a maximum sealed coil rating of 30 va each (0.25 amp at 120 vac, 0.13 amp at 230 vac). AHMS IFC-AUX contact must have minimum pilot duty rating of 400 va each (3.4 amps at 120 vac, 1.8 amps at 230 vac).
5. Replacement of factory wires must be with type 105 C wire or its equivalent.
6. Field-supplied liquid line solenoid valves installed at the evaporator are required on all units.
7. Units have 175 va of power available for field-installed accessories.

| | | | |
|--------------|--|-------------|--|
| AHMS | — Air Handler Motor Starter | SDR | — Solenoid Drop Relay |
| AUX | — Auxiliary | TB | — Terminal Block |
| C | — Compressor Contactor | TBX | — Terminal Block for Variable Air Volume Units |
| FU | — Fuse | TM | — Timer Motor |
| GND | — Equipment Ground | TR | — Timer Relay |
| IFC | — Indoor Fan Control | TRAN | — Transformer |
| kcmil | — Thousand Circular Mils | U | — Unloader Solenoid |
| LLS | — Liquid Line Solenoid | — | — Factory Wiring |
| NEC | — National Electrical Code (U.S.A. Standard) | --- | — Field Wiring |

Fig. 28 — Field Wiring, Single ModuPanel™ Control, Units 38AH124 and 134

Table 15 — Main Power Connection and Control Circuit Wiring

| MAIN POWER CONNECTION | | | | CONTROL CIRCUIT | |
|--------------------------------------|---------------------|--------------------------|-----------------------|-------------------|--------------------|
| Electrical Characteristics (V-Ph-Hz) | Qty Terminal Blocks | Qty Parallel Conductors* | Max Wire Size (kcmil) | Control Power (V) | Safety Circuit (V) |
| 208/230-3-60 | 1 | 6 | 500 | 115† | 24 |
| 460-3-60 575-3-60 | 1 | 3 | 500 | 115† | 24 |
| 230-3-50 | 1 | 6 | 500 | 230 | 24 |
| 380-3-60 380/415-3-50 | 1 | 3 | 500 | 230 | 24 |
| 346-3-50 | 1 | 3 | 500 | 200 | 24 |

LEGEND

kcmil — Thousand Circular Mills

*Conductors are from the safety disconnect.

†Control power is accomplished with a step-down transformer where primary voltage is field voltage.

Step 5 — Install Accessories

LOW-AMBIENT OPERATION

Units 38AH044-084, 124, and 134 — If operating temperatures below 55 F (13 C) are expected, Motormaster® III fan motor control is recommended. Refer to separate installation instructions for low-ambient operation guidelines.

Units 38AH094 and 104 — If operating temperatures below 45 F (7 C) are expected, Motormaster III fan motor control is recommended. Refer to separate installation instructions for low-ambient operation guidelines.

MISCELLANEOUS ACCESSORIES — For applications requiring special accessories, the following packages are available: condenser coil hail guard package, gage panel, unloader package, unloader conversion kits, sound reduction package, condenser coil protective grilles, compressor security grilles, ModuPanel™ control, and thermostat transformer relay package.

PRE-START-UP

IMPORTANT: Before beginning Pre-Start-Up or Start-Up, review Start-Up Checklist at the back of this publication. The Checklist assures proper start-up of a unit and provides a record of unit condition, application requirements, system information, and operation at initial start-up.

Do not attempt to start the air-conditioning system until following checks have been completed.

System Check

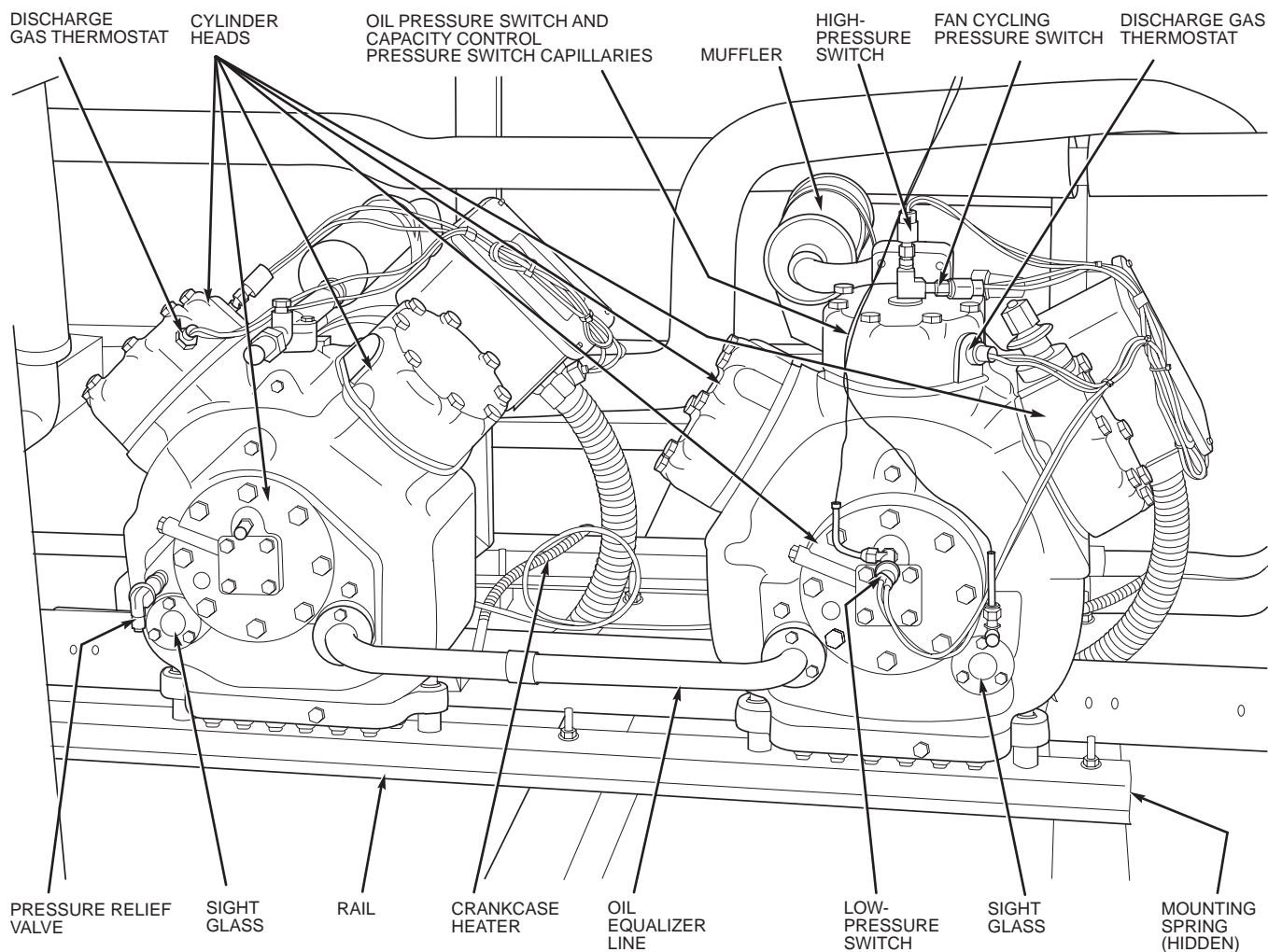
1. Check all system components, including the air-handling equipment. Consult manufacturer’s instructions. If the unit has field-installed accessories, be sure all are properly installed and wired correctly. Refer to unit wiring diagrams.

2. Backseat (open) compressor suction and discharge shut-off valves. Close valves one turn to allow refrigerant pressure to reach the test gages.
3. Open liquid line service valves.
4. Check tightness of all electrical connections.
5. Oil should be visible in the compressor sight glasses. See Fig. 29. An acceptable oil level in the compressor is from 1/8 to 1/3 of sight glass. Adjust the oil level as required. No oil should be removed unless the crankcase heater has been energized for at least 24 hours. See Preliminary Oil Charge section on page 38, for Carrier-approved oils.
6. Electrical power source must agree with unit nameplate.

⚠ CAUTION

Crankcase heaters on all units are wired into the control circuit, so they are always operable as long as the main power supply disconnect is on (closed), even if any safety device is open. Compressor heaters must be on for 24 hours prior to the start-up of any compressor.

7. Crankcase heaters must be firmly locked into compressors, and must be on for 24 hours prior to start-up.
8. Fan motors are 3-phase. Check rotation of fans during first start-up check. Fan rotation is clockwise as viewed from top of unit. If fan is not turning clockwise, reverse 2 of the power wires.
9. Check compressor suspension. On units 38AH044-084, 124, and 134, snubber washers (for noise suppression) can be moved with finger pressure. On units 38AH094 and 104, rails allow compressors to float freely on compressor rail springs.
10. On 38AH074,084 single-circuit units and Module 38AH134B, ensure that the packaging block located between the oil equalization tube and the compressor cross-brace has been removed.



NOTE: Units 38AH044-084 and 38AH124, 134 compressors are pan mounted. Units 38AH094 and 104 compressors are mounted on rails.

Fig. 29 — 06E Compressors, Typical

START-UP

Compressor crankcase heaters must be on for 24 hours before start-up. To energize the crankcase heaters, set the space thermostat above the ambient so there will be no demand for cooling. Close the field disconnect and turn on the fan circuit breakers. Leave the compressor circuit breakers off/open. The crankcase heaters are now energized.

Preliminary Checks

1. Ensure that compressor service valves are backseated.
2. Verify that each compressor on units 38AH044-084, 124, and 134 floats freely on its mounting springs. Verify that each compressor on units 38AH094 and 104 floats freely on its rails.
3. Check that electric power supply agrees with unit nameplate data.
4. Verify that compressor crankcase heaters are securely in place.
5. Check that compressor crankcase heaters have been on at least 24 hours.
6. Note that compressor oil level is visible in the sight glass.
7. Recheck for leaks using same procedure as previously outlined in Step 3 — Make Refrigerant Piping Connections, page 14.

8. If any leaks are detected, evacuate and dehydrate as previously outlined in Step 3 — Make Refrigerant Piping Connections, page 14.

Preliminary Oil Charge — Each compressor is factory charged with oil (see Table 3A, 3B, 4A, or 4B). When oil is checked at start-up, it may be necessary to add or remove oil to bring it to the proper level. One recommended oil level adjustment method is as follows:

ADD OIL — Close suction shutoff valve and pump down crankcase to 2 psig (14 kPa). (Low-pressure cutout must be jumped.) Wait a few minutes and repeat until pressure remains steady at 2 psig (14 kPa). Remove oil fill plug above the oil level sight glass, add oil through plug hole, and replace plug. Run compressor for 20 minutes and check oil level.

IMPORTANT: For units with 2 compressors per refrigeration circuit, *both compressors must be running* to adjust the oil level. Two oil level equalizer lines between compressors distribute the oil to each compressor.

NOTE: Use only Carrier approved compressor oil. Approved sources are: Petroleum Specialties Inc. (Cryol 150A), Texaco, Inc. (Capella WF-32-150), and Witco Chemical Co. (Suniso 3GS). Do not reuse oil that has been drained out, or oil that has been exposed to atmosphere.

REMOVE OIL — Pump down compressor to 2 psig (14 kPag). Loosen the ¼-in. (6.4-mm) pipe plug at the compressor base and allow the oil to seep out past the threads of the plug.

NOTE: The crankcase will be slightly pressurized. Do not remove the plug, or the entire oil charge will be lost.

Small amounts of oil can be removed through the oil pump discharge connection while the compressor is running.

Preliminary Charge — Refer to GTAC II (General Training Air Conditioning), Module 5, Charging, Recovery, Recycling, and Reclamation for charging procedures. Using the liquid charging method and charging by weight procedure, charge each circuit with the amount of R-22 listed in Table 3A, 3B, 4A, or 4B.

⚠ CAUTION

Never charge liquid into the low-pressure side of system. Do not overcharge. During charging or removal of refrigerant, be sure indoor-fan system is operating.

Start Unit — The field disconnect is closed, the fan circuit breaker is closed, and the space thermostats are set above ambient so that there is no demand for cooling. Only the crankcase heaters are energized.

Close the compressor circuit breakers and then reset both space thermostats below ambient so that a call for stage one cooling is ensured. *Lead refrigeration circuit thermostat TC1 must be set to call for cooling at a lower temperature than lag refrigeration circuit thermostat TC2.* See Table 16 for lead/lag circuits on all units. Now set TC2 for cooling.

NOTE: Do not use circuit breakers to start and stop the compressor except in an emergency.

38AH044-084 DUAL-CIRCUIT UNITS — Start-up of lead compressor A1 (Table 16) will be delayed from 12 seconds to 5½ minutes from the time the call for cooling is initiated by TC1. After the lead compressor starts, close the TC2 thermostat to start lag circuit compressor B1. Compressor B1 will start a minimum of 60 seconds after thermostat TC2 is closed.

38AH044-084 OPTIONAL SINGLE CIRCUIT UNITS — Start-up of lead compressor A1 (Table 16) is delayed from 12 seconds to 5½ minutes from the time the call for cooling is initiated by TC1. Closure of TC2 will actuate LLS-A2. Lag compressor A2 is controlled by D-D2 timer contacts and capacity control pressure switches (CCPSs) which monitor compressor suction pressure. The lag compressor starts approximately 2½ minutes after the lead compressor starts if the suction pressure is above the CCPS set point.

38AH094,104 UNITS — Start-up of lead circuit A, compressor A1 (Table 16) is delayed from 12 seconds to 5½ minutes from the time the call for cooling is initiated. After lead circuit A, compressor A1 starts, close refrigeration circuit thermostat TC2 to start lag circuit B, lead

compressor B1. Start-up of compressor B1 is delayed from 12 seconds to 5½ minutes. (Circuit B of unit 38AH094 has only one compressor.)

Each circuit's lead compressor start-up is controlled by the unit control timer. The circuit's lag compressor start-up is controlled by the D-D2 timer contacts and capacity control pressure switches (CCPSs) which monitor compressor suction pressure. The circuit's lag compressor will start approximately 2½ minutes after a call for cooling if compressor pressure is above CCPS set point.

38AH124,134 UNITS — Start-up of the lead circuit (Module 124A or 134A) lead compressor A1 (Table 16) is delayed from 12 seconds to 5½ minutes from the time the call for cooling is initiated by TC1. Lag compressor A2 is controlled by D-D2 timer contacts and capacity control pressure switches (CCPSs) which monitor compressor suction pressure. The lag compressor starts approximately 2½ minutes after the lead compressor starts if the suction pressure is above the CCPS set point.

After the lead circuit (Module 124A or 134A) lead compressor A1 (Table 16) starts, close the TC2 thermostat to start the lag circuit (Module 124B or 134B) lead compressor (A1). Lag circuit compressor A1 start-up is delayed from 12 seconds to 5½ minutes from the time the call for cooling is initiated by TC2. Lag compressor A2 is controlled by D-D2 timer contacts and CCPSs which monitor compressor suction pressure. Lag compressor A2 starts approximately 2½ minutes after lead compressor A1 starts if the suction pressure is above the CCPS set point.

Adjust Refrigerant Charge

⚠ CAUTION

Never charge liquid into the low-pressure side of system. Do not overcharge. During charging or removal of refrigerant, be sure indoor-fan system is operating.

With all fans operating, and all compressors on the circuit being serviced operating at full capacity, adjust the refrigerant charge in accordance with the unit charging charts located on the inside of the control box doors and in Fig. 30-43. Charge vapor into compressor low-side service port located above oil pump crankshaft housing. Measure pressure at the liquid line service valve, making sure a Schrader depressor is used if required. Also, measure liquid line temperature as close to the liquid service valve as possible. Add charge until the pressure and temperature conditions of the charging chart curve are met. If liquid pressure and temperature point fall above curve, add charge. If liquid pressure and temperature point fall below curve, reduce the charge until the conditions match the curve.

If the sight glass at location A (Fig. 11 and 12) is cloudy, check refrigerant charge again. *Ensure all fans and compressors on the circuit being serviced are operating.* Also ensure maximum allowable liquid lift has not been exceeded.

If the sight glass at location A is clear and the sight glass at location B is cloudy, a restriction exists in the line between the 2 sight glasses. Check for a plugged filter drier or partially open solenoid valve. Replace or repair, as needed.

Table 16 — Index of Lead/Lag Circuits and Compressors

| UNIT 38AH | 044-084 STD | 044-084 OPT | 094 | 104 | 124 | 134 |
|---|----------------|----------------|----------|----------|----------------|----------------|
| LEAD CIRCUIT | A | A | A | A | Module 124A | Module 134A |
| Compressor, Lead Compressor; Lag | A1 * | A1 A2 | A1 A2 | A1 A2 | A1 A2 | A1 A2 |
| LAG CIRCUIT | B | † | B | B | Module 124B | Module 134B |
| Compressor, Lead Compressor; Lag | B1 * | | B1 * | B1 B2 | A1 A2 | A1 A2 |

LEGEND

OPT — Optional Single-Circuit Units

STD — Standard Dual-Circuit Units

*Circuit has only one compressor.

†Units have only one circuit.

Check Compressor Oil Level — After adjusting the refrigerant charge, allow each circuit to run fully loaded for 20 minutes. Running oil level should be $\frac{1}{8}$ to $\frac{1}{3}$ up on the sight glass. Stop the compressors at the field power supply disconnect and check the crankcase oil level. Add oil only if necessary to bring the oil into view in the sight glass. If oil is added, run the circuit for an additional 10 minutes, then stop and check oil level. If the level remains low, check the piping system for proper design for oil return; also, check the system for leaks.

If the initial check shows too much oil (too high in the sight glass) remove oil to proper level. See Preliminary Oil Charge for proper procedure for adding and removing oil.

When the above checks are complete, repeat the procedure with the unit operating at minimum load conditions.

UNITS 38AH044-084,124, AND 134 — For this minimum load check, run the lead compressor of each refrigeration circuit fully unloaded with the lag compressor not operating.

Unload the compressor(s) by turning the control set point adjustment nut counterclockwise until the adjustment nut stops. The unloader is now at 0 psig (0 kPag) set point. If

electrically actuated unloaders are installed, energize the solenoid to unload the compressor. Recheck the compressor oil level as described in Check Compressor Oil Level above.

Return unloader to original setting after checks are complete.

UNITS 38AH094,104 — For this minimum load check, the lead compressor (A1, B1) of each refrigeration circuit is unloaded. See Table 16. The lag compressor (A2, B2 [38AH104 only]) of each refrigeration circuit must not be operating.

Unload the compressor(s) by turning the control set point adjustment nut counterclockwise until the adjustment nut stops. The unloader is now at 0 psig (0 kPag) set point. If electrically actuated unloaders are installed, energize the solenoid to unload the compressor.

Return unloader to original setting after checks are complete.

Final Checks — Ensure all safety controls are operating, control panel covers are on, and the service panels are in place.

ALL OUTDOOR FANS MUST BE OPERATING

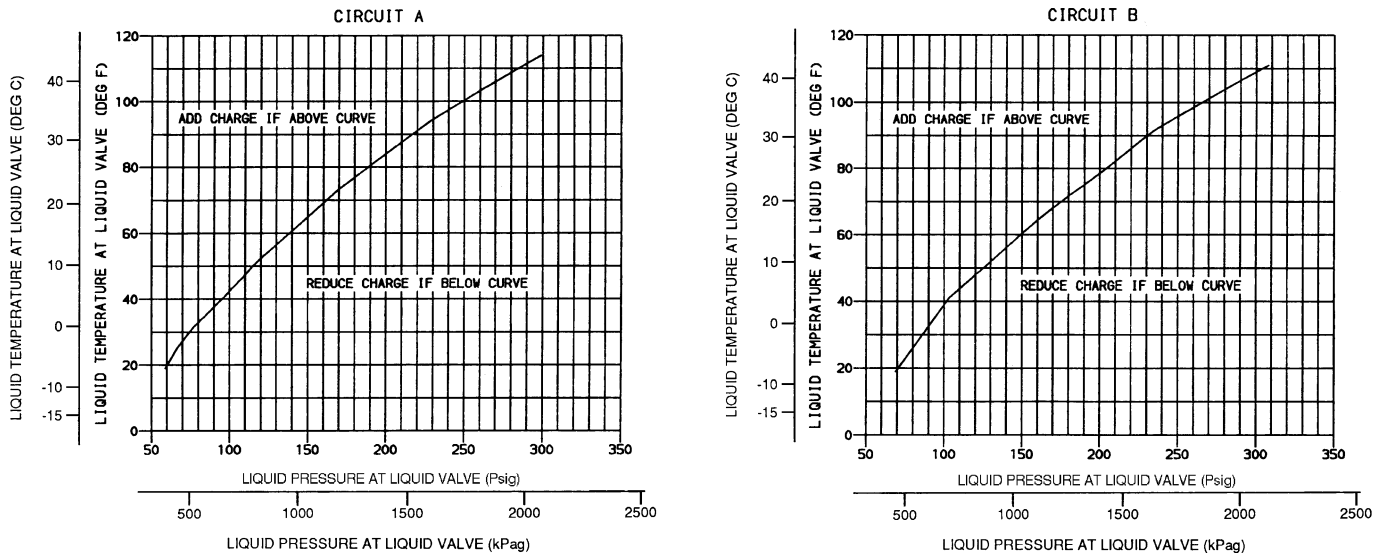


Fig. 30 — Charging Chart — Unit 38AH044; 50/60 Hz — Dual Circuit

ALL OUTDOOR FANS MUST BE OPERATING

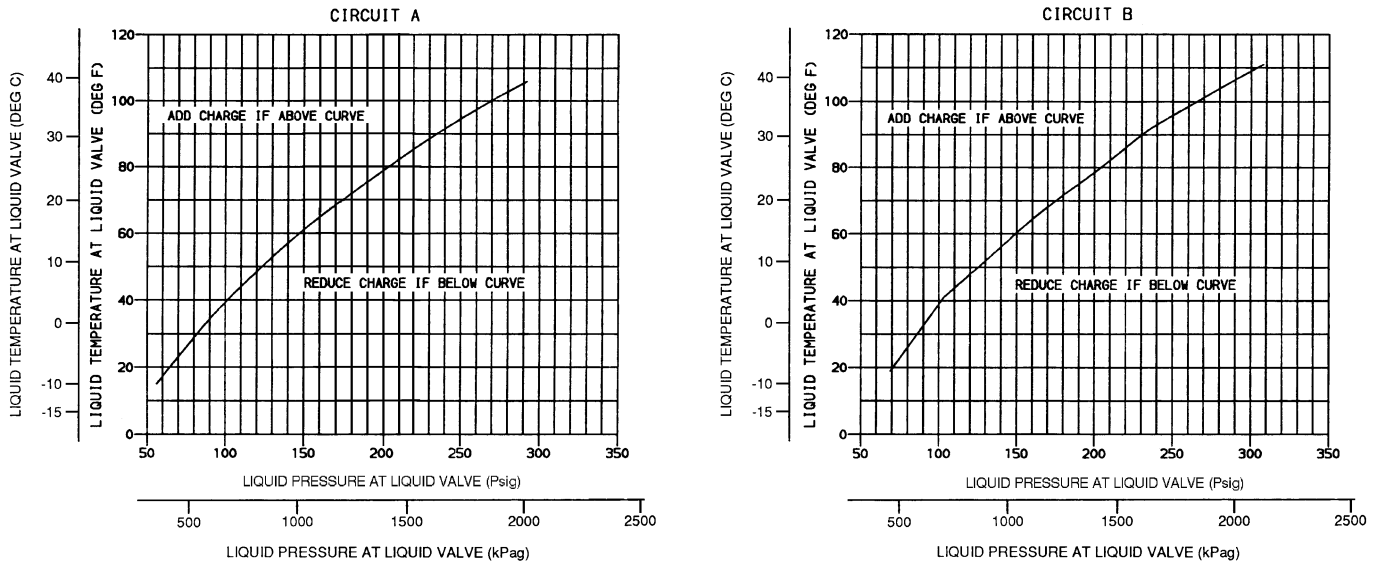


Fig. 31 — Charging Chart — Unit 38AH054; 50/60 Hz — Dual Circuit

ALL OUTDOOR FANS MUST BE OPERATING

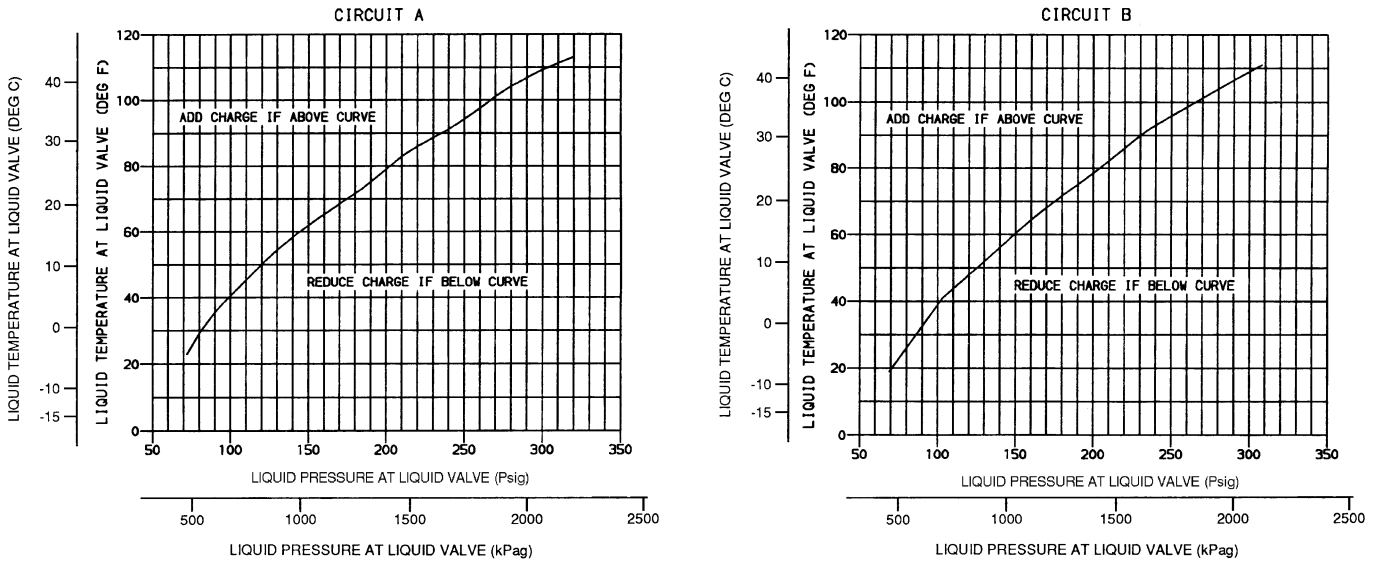


Fig. 32 — Charging Chart — Unit 38AH064; 50/60 Hz — Dual Circuit

ALL OUTDOOR FANS MUST BE OPERATING

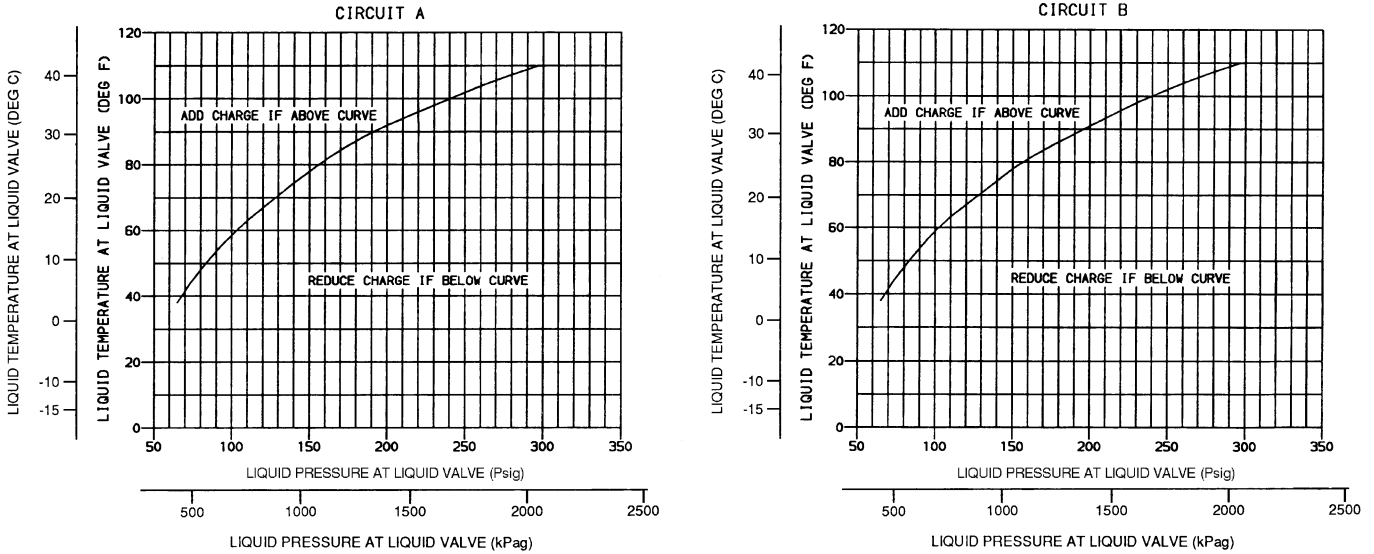


Fig. 33 — Charging Chart — Unit 38AH074; 50/60 Hz — Dual Circuit

ALL OUTDOOR FANS MUST BE OPERATING

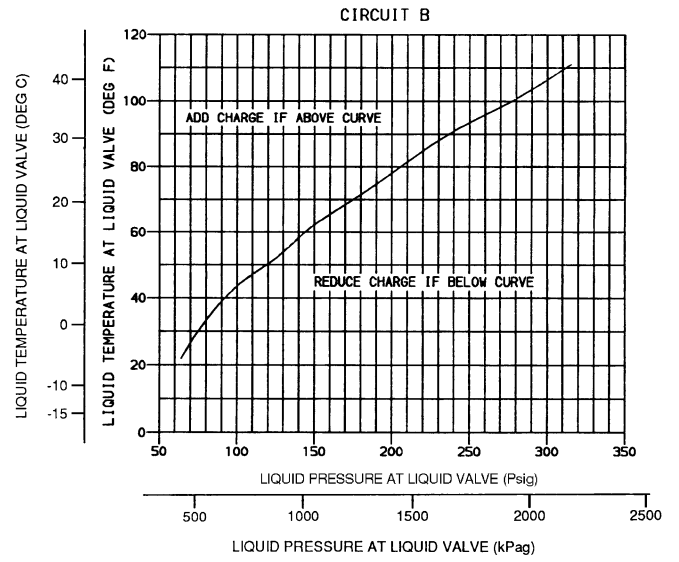
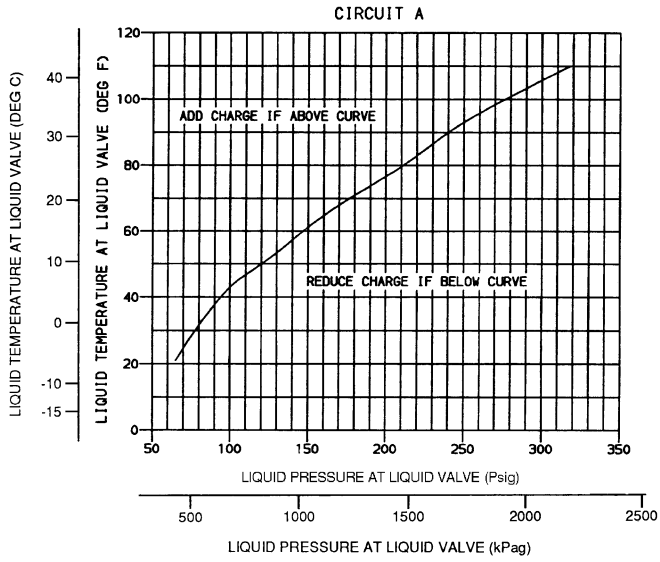


Fig. 34 — Charging Chart — Unit 38AH084; 50/60 Hz — Dual Circuit

ALL OUTDOOR FANS MUST BE OPERATING
SINGLE CIRCUIT

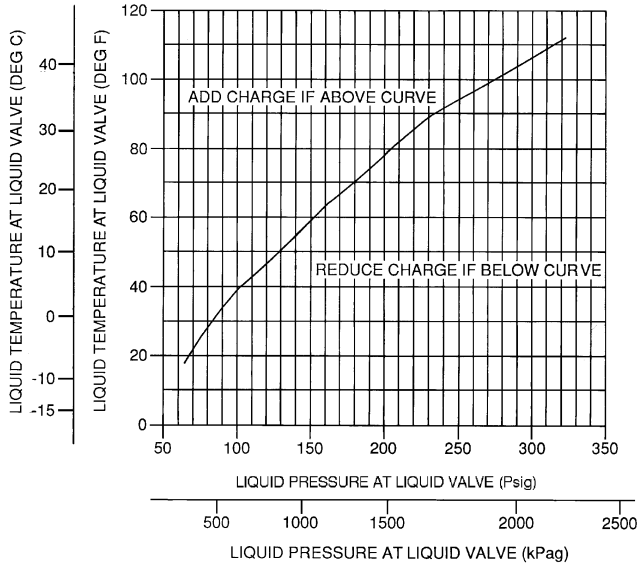


Fig. 35 — Charging Chart — Unit 38AH044; 50/60 Hz — Optional Single Circuit

ALL OUTDOOR FANS MUST BE OPERATING
SINGLE CIRCUIT

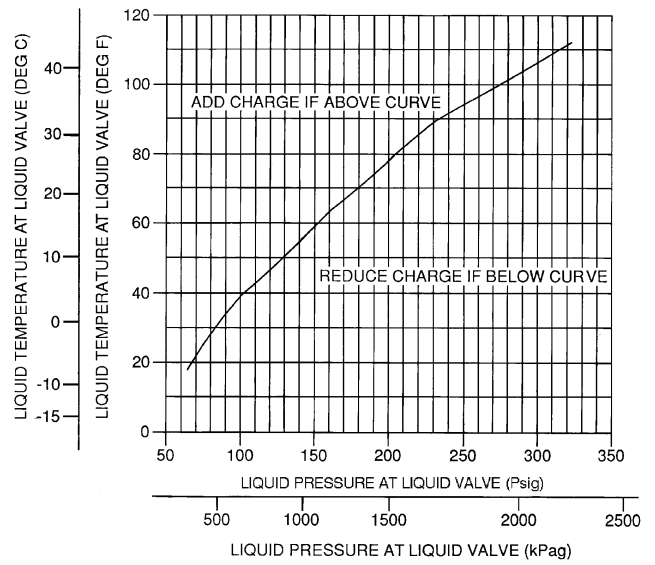
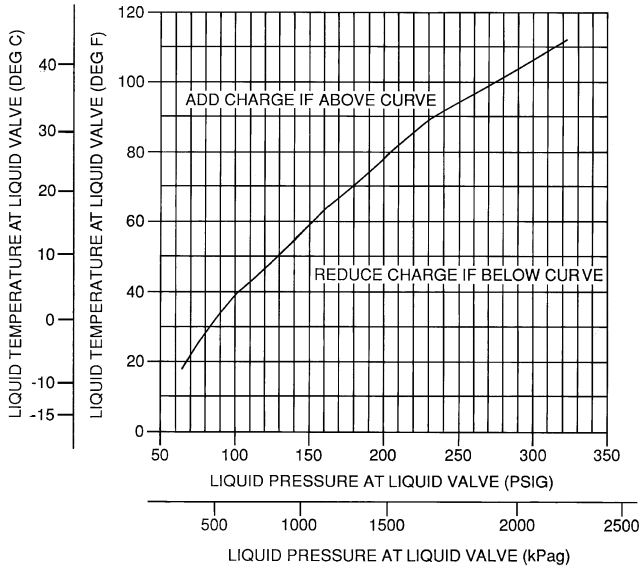


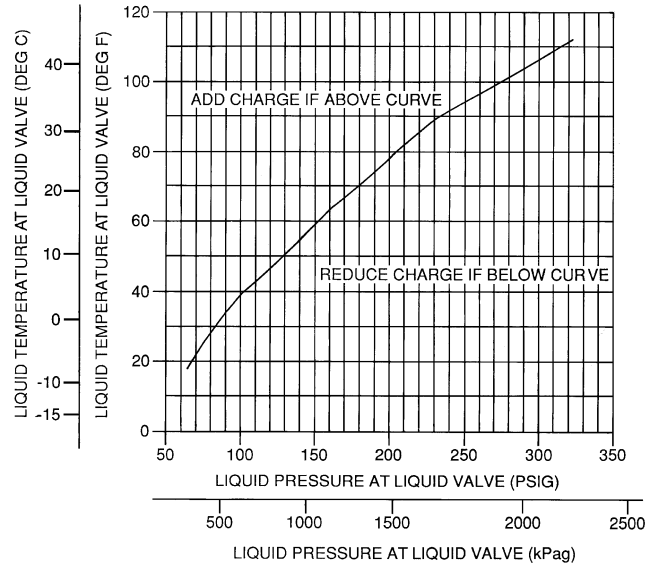
Fig. 36 — Charging Chart — Unit 38AH054; 50/60 Hz — Optional Single Circuit

ALL OUTDOOR FANS MUST BE OPERATING
SINGLE CIRCUIT



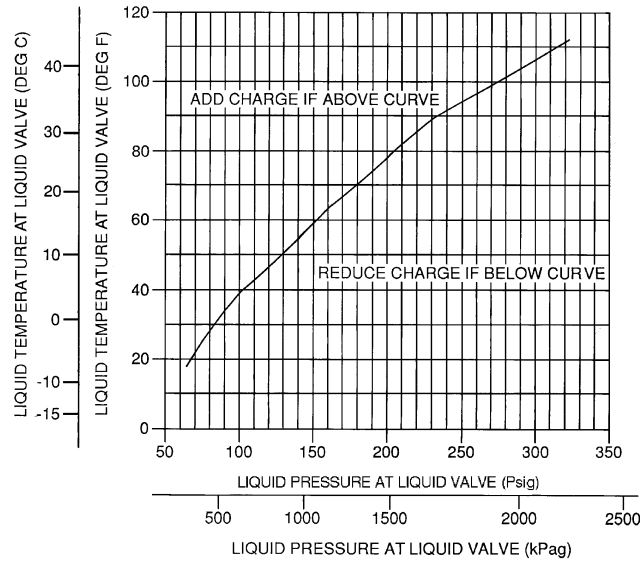
**Fig. 37 — Charging Chart — Unit 38AH064;
50/60 Hz — Optional Single Circuit**

ALL OUTDOOR FANS MUST BE OPERATING
SINGLE CIRCUIT

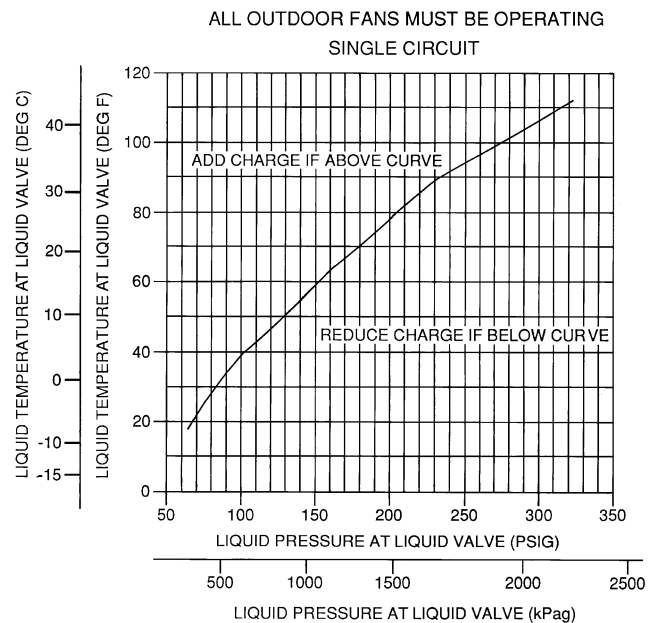
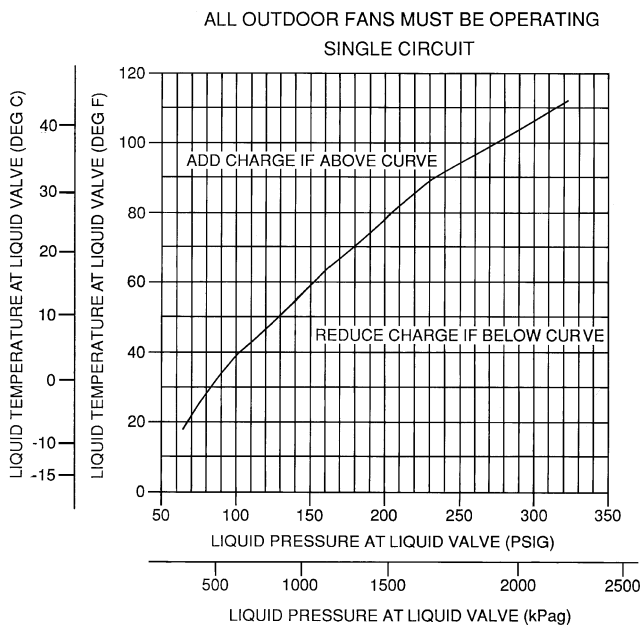
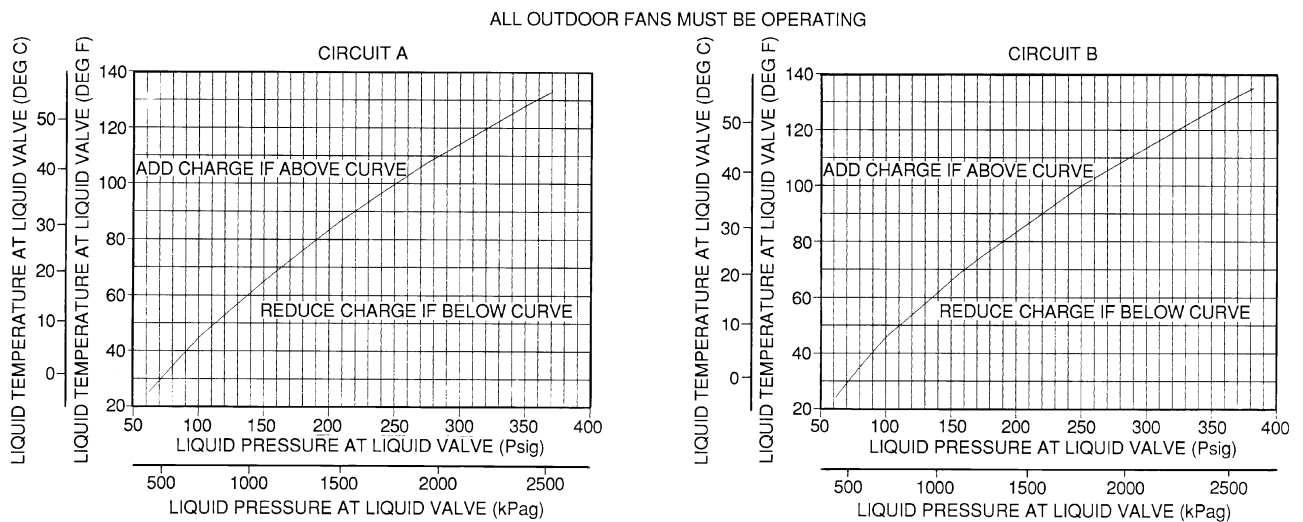
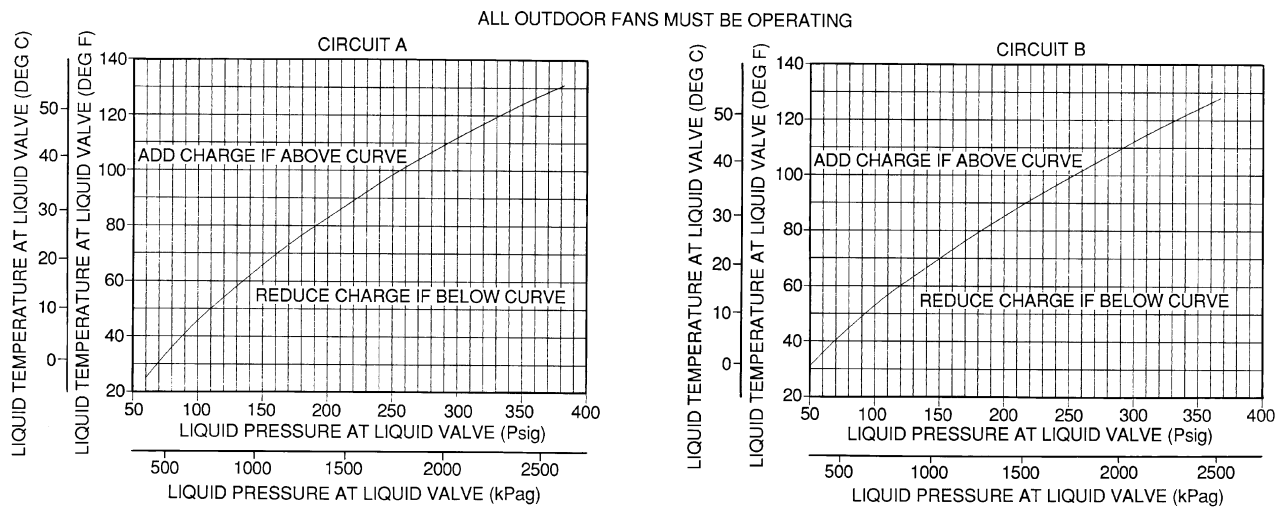


**Fig. 38 — Charging Chart — Unit 38AH074;
50/60 Hz — Optional Single Circuit**


ALL OUTDOOR FANS MUST BE OPERATING
SINGLE CIRCUIT



**Fig. 39 — Charging Chart — Unit 38AH084;
50/60 Hz — Optional Single Circuit**



SERVICE

| | |
|---|--|
|  | <p>ELECTRIC SHOCK HAZARD Turn off all power to unit before servicing. The ON-OFF switch on control panel does <i>not</i> shut off control power; <i>use field disconnect.</i></p> |
|---|--|

Coil Cleaning — Clean the coils with a vacuum cleaner, compressed air, water, or a non-wire bristle brush.

Refrigerant Circuit

LEAK TESTING — Units are shipped with a holding charge of R-22 (see Table 3A, 3B, 4A, or 4B) and should be under sufficient pressure to conduct a leak test. If there is no pressure in the system, introduce enough nitrogen to search for the leak. Repair the leak using good refrigeration practices. After leaks are repaired, system must be evacuated and dehydrated using methods described in GTAC II, Module 4, System Dehydration.

REFRIGERANT CHARGE (Refer to Table 3A, 3B, 4A, or 4B) — At the liquid line connection point on each circuit is a factory-installed liquid line service valve. On each valve is a 1/4-in. Schrader connection for charging liquid refrigerant.

Charging with Unit Off and Evacuated — Close liquid line service valve before charging. Weigh in charge shown in Table 3A, 3B, 4A, or 4B. Open liquid line service valve; start unit and allow it to run several minutes fully loaded. Check for a clear sight glass. Be sure clear condition is liquid and not vapor. Complete charging the unit in accordance with Start-Up, Adjust Refrigerant Charge, page 39.

Charging with Unit Running — If charge is to be added while unit is operating, it is necessary to have all condenser fans and compressors operating. It may be necessary to block condenser coils at low-ambient temperatures to raise condensing pressure to approximately 280 psig (1931 kPag) to turn all condenser fans on. Do not totally block a coil to do this. Partially block all coils in uniform pattern. Charge vapor into compressor low-side service port located above oil pump crankshaft housing. Charge each circuit until sight glass shows clear liquid.

Troubleshooting — Refer to Troubleshooting chart located at back of book.

Oil Pressure Safety Switch (OPS) — An oil pressure safety switch for each of the independent refrigerant circuits shuts off the compressor in that circuit if oil pressure is not established at start-up or maintained during operation. If the OPS stops the unit, determine and correct the cause before restarting the unit. *Failure to do so constitutes equipment abuse and could affect the warranty.*

Compressor Motor Protection

CIRCUIT BREAKER — A manual reset, calibrated trip circuit breaker for each compressor protects against overcurrent. *Do not bypass connections or increase size of circuit breaker for any reason. If trouble occurs, determine the cause and correct it before resetting the breaker.*

DISCHARGE GAS THERMOSTAT — A sensor in the cylinder head of each compressor (Fig. 29) shuts down the compressor if excessively high discharge gas temperature is sensed. If the discharge gas thermostat shuts the unit down, it may be reset by the thermostat or power disconnect switch.

CRANKCASE HEATER (See Fig. 29) — Each compressor has an electric crankcase heater located in the bottom cover.

The heater is held in place by a clip and bracket and must be tightly connected since exposure to the air causes the heater to burn out. Each heater is wired into the compressor control circuit through a relay which energizes only when the compressor is off. The heater keeps the oil at a temperature that prevents excessive absorption of refrigerant during shutdown periods.

Energize the crankcase heaters when the unit is not running except during prolonged shutdown or servicing. *Energize the heaters at least 24 hours before restarting the unit after prolonged shutdown.*

TIME GUARD® FUNCTION — This function prevents compressors from short-cycling.

Fan Motor Protection — Fan motors are protected by a single circuit breaker for all motors.

Head Pressure Control — Head pressure control reduces condenser capacity under low-ambient conditions. This is achieved by fan cycling control (standard, all units) and Motormaster® III control accessory (field installed).

FAN CYCLING — All condensing units have standard provision for fully automatic intermediate season head pressure control through fan cycling (see Table 17).

38AH044-084 Dual-Circuit Units — Fans no. 3 and 4 are cycled by pressure control on all units. On 38AH074 and 084, fans no. 5 and 6 are also cycled by pressure control.

38AH044-084 Optional Single Circuit Units — Fans no. 3 and 4 are cycled by pressure control on all units. On 38AH074 and 084, fans no. 5 and 6 are cycled by an air-temperature switch located in the bottom shelf of the control box.

Units 38AH094,104 — Fans no. 3 through 6 are cycled by pressure control.

Units 38AH124,134 — Fans no. 3 and 4 on each unit module are cycled by pressure control. On module 134B only, fans no. 5 and 6 are cycled by an air-temperature switch located in the bottom shelf of the control box.

Pressure control is achieved via a fan cycling pressure switch located on the cylinder head of the unit or circuit lead compressor (see Fig. 29).

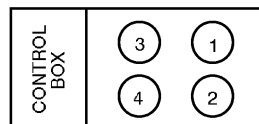
The air-temperature switch used to control fans no. 5 and 6 on 38AH074,084 optional single-circuit units and on module 134B is closed and cycles the fans on when the ambient-air temperature is above 70 F (21 C).

Table 17 — Fan Cycling Control — Psig (kPag)

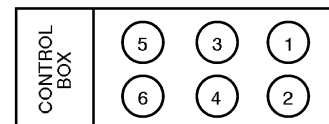
| | |
|--|------------------------|
| Control by Pressure* Switch Opens | ±10 (69) 160 (1103) |
| Switch Closes | 255 (1758) |

*On all units, fans no. 3 and 4; also on unit 38AH074, 084 (dual-circuit units only) and 38AH094,104, fans no. 5 and 6.

NOTE: Fans no. 1 and 2 are noncycling. Units 38AH074,084 optional single-circuit units and module 134B fans no. 5 and 6 are cycled by an air-temperature switch which operates above 70 F (21 C) ambient-air temperature.



38AH044-064,
Modules 124A, 124B,
134A



38AH074-104,
Module 134B

Winter Start Control — A 2½-minute low-pressure switch (LPS) bypass function in the timer prevents nuisance LPS trips during start-up in low-ambient conditions.

High-Pressure Switch — This switch has nonadjustable settings. Figure 29 shows connection on a cylinder head. See Table 18 for pressure switch settings.

NOTE: High-pressure switch must be removed from cylinder head before removing compressor from the unit.

TO CHECK — Slowly close the discharge shutoff valve until the compressor shuts down. This should be at approximately 426 psig (2935 kPag). Slowly open the valve. When the pressure drops to approximately 320 psig (2205 kPag), the pressure switch resets. To reenergize the control circuit, manually switch the fan circuit breaker off and then on. The compressor starts again under Time Guard® controls.

Low-Pressure Switch — The low-pressure switch (LPS) has fixed nonadjustable settings. It is located at the pump end of the compressor above the bearing head. See Table 18 for pressure switch settings.

TO CHECK — Slowly close the suction cut-off valve and allow the compressor to shut down. This should occur at approximately 27 psig (186 kPag). Slowly open the valve. The compressor restarts under Time Guard control when the pressure builds to approximately 67 psig (462 kPag).

Table 18 — Pressure Switch Settings, Psig (kPag)

| SWITCH | CUTOUT | CUT-IN |
|--------|------------------------|--------------------------|
| High | 426 ± 7 (2935 ± 48) | 320 ± 20 (2205 ± 138) |
| Low | 27 ± 4 (186 ± 28) | 67 ± 7 (462 ± 48) |

Capacity Control

38AH044-084 DUAL-CIRCUIT UNITS — Capacity control is achieved by a pressure-actuated cylinder bank unloader on lead compressor A1. As the cooling load decreases and the suction pressure drops, the unloader actuates at the pre-set suction pressure and unloads the cylinder bank. (See Fig. 44 and Table 19A.) The unloading of the compressor cylinder bank has no effect on the operation of lag compressor B2, which is controlled by TC2.

38AH044-084 SINGLE-CIRCUIT UNITS AND MODULES 124A, 124B, 134A, AND 134B — Capacity control is achieved by a pressure-actuated cylinder bank unloader on lead compressor A1. See Table 16. As the cooling load decreases and the suction pressure drops, the unloader actuates at the pre-set suction pressure and unloads the cylinder bank. (See Fig. 44 and Table 19B and 20.) Lag compressor A2 is controlled by fixed setting capacity control pressure switches (CCPSs) as follows:

| | CUT-IN — Psi (kPa) | CUTOUT — Psi (kPa) |
|--------|-----------------------|-----------------------|
| CCPS 1 | 83 (572) | 63 (531) |
| CCPS 2 | 80 (551) | 53 (365) |

CCPS — Capacity Control Pressure Switch

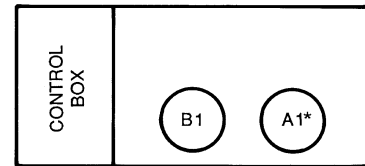
If suction pressure continues to drop after lead compressor A1 unloads and lag compressor A2 is operating, A2 will stop operating when the suction pressure drops to the CCPS cutout point.

38AH094,104 — Capacity control is achieved by a pressure-actuated cylinder bank unloader on the lead compressor (A1, B1) on each of the 2 refrigeration circuits. As the cooling load decreases and the suction pressure drops, the unloader actuates at the pre-set suction pressure and unloads the cylinder bank. (See Fig. 44 and Table 20.) The unloading of the compressor cylinder bank has no effect on the operation of the circuit lag compressor (A2, B2 [except 38AH094, circuit B]) which is controlled by fixed setting capacity control pressure switches (CCPSs) as follows:

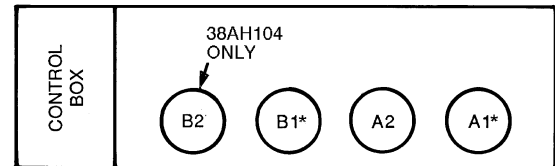
| | CUT-IN — Psi (kPa) | CUTOUT — Psi (kPa) |
|--------|-----------------------|-----------------------|
| CCPS 1 | 83 (572) | 63 (531) |
| CCPS 2 | 80 (551) | 53 (365) |

CCPS — Capacity Control Pressure Switch

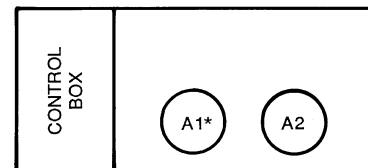
Pressure Relief — High-side pressure relief is provided by a fusible plug in the liquid line at the service valve. For low-side pressure relief, a fusible plug is inserted in the side of the accumulator (all units except 38AH044-084 dual-circuit, constant-volume units). See Fig. 45. The 38AH044-084 dual-circuit, constant-volume units have a fusible plug in the suction tubing. A pressure relief valve installed on the compressor relieves at 450 psig (3102 kPag) (see Fig. 1-6).



COMPRESSORS - 38AH044-084
DUAL-CIRCUIT UNITS



COMPRESSORS - 38AH094,104 UNITS



COMPRESSORS - 38AH044,084
SINGLE-CIRCUIT UNITS;
MODULES 124A, 124B, 134A, 134B

Unloader Settings

| | |
|---------------------|----------|
| Unload, psig (kPag) | 56 (386) |
| Load, psig (kPag) | 76 (524) |

*Unloader location.

Fig. 44 — Unloader Location and Settings

Table 19A — One 2-Stage Thermostat Capacity Control for 38AH044-084 Dual-Circuit Units

| UNIT 38AH | QUANTITY OF LOADED COMPRESSOR CYLINDERS | | | SYSTEM CAPACITY (%) |
|-----------|---|-----------|-------|---------------------|
| | Circuit A | Circuit B | Total | |
| 044 | 4 | 4 | 8 | 100 |
| | 2 | 4 | 6 | 75 |
| | 4 | 0 | 4 | 50 |
| | 2 | 0 | 2 | 25 |
| | 4 | 6 | 10 | 100 |
| 054 | 2 | 6 | 8 | 79 |
| | 2 | 4 | 6* | 59 |
| | 4 | 0 | 4 | 42 |
| | 2 | 0 | 2 | 21 |
| | 6 | 6 | 12 | 100 |
| 064 | 4 | 6 | 10 | 84 |
| | 2 | 6 | 8* | 68 |
| | 6 | 0 | 6 | 48 |
| | 4 | 0 | 4 | 32 |
| | 2 | 0 | 2* | 16 |
| 074 | 6 | 6 | 12 | 100 |
| | 4 | 6 | 10 | 86 |
| | 2 | 6 | 8* | 72 |
| | 6 | 0 | 6 | 43 |
| | 4 | 0 | 4 | 29 |
| 084 | 2 | 0 | 2* | 15 |
| | 6 | 6 | 12 | 100 |
| | 4 | 6 | 10 | 83 |
| | 2 | 6 | 8* | 66 |
| | 6 | 0 | 6 | 50 |
| 084 | 4 | 0 | 4 | 33 |
| | 2 | 0 | 2* | 17 |

*Requires units with VAV (variable air volume) factory-supplied option.

NOTE: Units have 2 independent refrigeration circuits. Circuit A is lead circuit.

Table 19B — One 2-Stage Thermostat Capacity Control for 38AH044-084 Optional Single-Circuit Units

| UNIT 38AH | QUANTITY OF LOADED CYLINDERS | SYSTEM CAPACITY (%) |
|-----------|------------------------------|---------------------|
| 044 | 8 | 100 |
| | 6 | 75 |
| | 4 | 50 |
| | 2 | 25 |
| 054 | 10 | 100 |
| | 8 | 81 |
| | 6 | 60 |
| | 6 | 56 |
| | 4 | 37 |
| 064 | 2* | 19* |
| | 12 | 100 |
| | 10 | 82 |
| | 8 | 64 |
| | 6 | 56 |
| 074 | 4 | 36 |
| | 2† | 18 |
| | 12 | 100 |
| | 10 | 81 |
| | 8 | 62 |
| 084 | 6 | 57 |
| | 4 | 38 |
| | 2† | 19 |
| | 12 | 100 |
| | 10 | 83 |
| 084 | 8 | 66 |
| | 6 | 50 |
| | 4 | 33 |
| | 2† | 17 |

*Requires accessory unloader on lead 06E-265 compressor (A1).

†Requires VAV (variable air volume) factory-installed option or accessory unloader.

Table 20 — One 2-Stage Thermostat Capacity Control for 38AH094-134 Units

| UNIT 38AH | QUANTITY OF LOADED COMPRESSOR CYLINDERS | | | SYSTEM CAPACITY (%) |
|-----------|---|-------|-------|---------------------|
| | Ckt A | Ckt B | Total | |
| 094 | 10 | 6 | 16 | 100 |
| | 10 | 4 | 14 | 85 |
| | 10 | 2 | 12 | 70* |
| | 10 | 0 | 10 | 55 |
| | 8 | 0 | 8 | 44 |
| | 6 | 0 | 6 | 33 |
| | 4 | 0 | 4 | 22 |
| 104 | 10 | 12 | 22 | 100 |
| | 8 | 12 | 20 | 91 |
| | 8 | 10 | 18 | 82 |
| | 10 | 6 | 16 | 73 |
| | 6 | 6 | 12 | 55 |
| | 6 | 4 | 10 | 45 |
| | 0 | 6 | 6 | 27 |
| | 4 | 0 | 4 | 18 |
| | 0 | 4 | 4 | 18 |
| | 2† | 0 | 2 | 9† |
| 124 | 12 | 12 | 24 | 100 |
| | 10 | 12 | 22 | 92 |
| | 10 | 10 | 20 | 83 |
| | 8* | 10 | 18 | 75* |
| | 6 | 10 | 16 | 67 |
| | 6 | 8* | 14 | 58* |
| | 6 | 6 | 12 | 50 |
| | 4 | 6 | 10 | 42 |
| | 6 | 0 | 6 | 25 |
| | 4 | 0 | 4 | 17 |
| 134 | 2* | 0 | 2 | 8* |
| | 12 | 12 | 24 | 100 |
| | 10 | 12 | 22 | 92 |
| | 10 | 10 | 20 | 83 |
| | 8* | 10 | 18 | 75* |
| | 6 | 10 | 16 | 67 |
| | 6 | 8* | 14 | 58* |
| | 6 | 6 | 12 | 50 |
| | 4 | 6 | 10 | 42 |
| | 6 | 0 | 6 | 25 |
| 4 | 0 | 4 | 17 | |
| 134 | 2* | 0 | 2 | 8* |

*Requires VAV (variable air volume) unit or accessory unloader(s) field installed on circuit lead compressor. Lead compressor is identified in Table 16, page 40.

†Requires field-installed accessory unloader on circuit lead compressor. Lead compressor is identified in Table 16, page 40.

NOTES:

1. Temperatures calculated with the minimum number of fans operating per circuit.
2. See Table 16, page 40, for information on lead and lag circuits.

CONTROL SET POINT — Control set point (cylinder load point) is adjustable from 0 to 85 psig (0 to 586 kPag). To adjust the set point, turn the control set point adjustment nut clockwise to bottom stop. (See Fig. 46.) In this position, load-up set point is 85 psig (586 kPag). Turn adjustment counterclockwise to desired control set point. Every full turn clockwise decreases the load-up set point by 7.5 psig (52 kPag).

PRESSURE DIFFERENTIAL — Pressure differential (difference between cylinder load and unload points) is adjustable from 6 to 22 psig (41 to 152 kPag). To adjust, turn pressure differential adjustment screw counterclockwise to back stop position. The differential pressure is now adjusted to 6 psig (41 kPag). Turn the adjustment screw clockwise to adjust the differential pressure. Every full clockwise turn increases the differential by 1.5 psig (10 kPag).

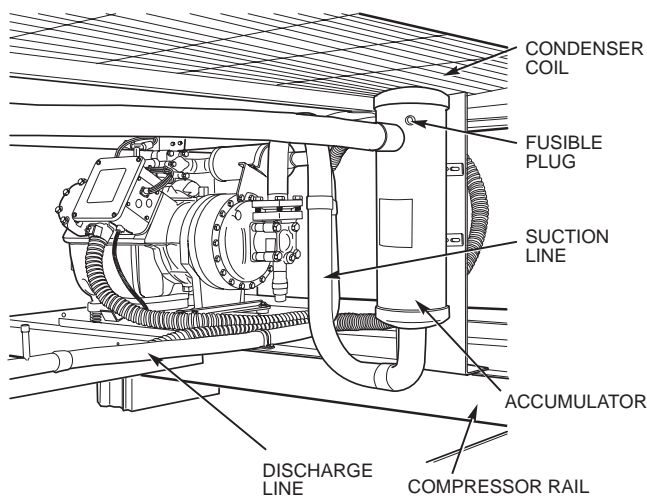


Fig. 45 — Accumulator and Fusible Plug

Timer Functions — (See Timer Cycle, Fig. 47.) Each refrigeration circuit is controlled by an independent timer which allows for the independent operation of each refrigeration circuit.

NOTE: Unit 38AH044-084 optional single-circuit units have one timer which controls the lead compressor. Lag compressor is controlled by CCPS (capacity control pressure switch).

SWITCH A — The timer is energized through contacts A-A1 or A-A2. This establishes the Time Guard® function which prevents compressor short-cycling. Start of compressor is delayed approximately 5.5 minutes after shutdown.

SWITCH B — The compressor is initially energized through contacts B-B1.

SWITCH D — Contacts D-D1 provide a 2½-minute bypass of the low-pressure switch at start-up for winter-start control. On 38AH044-084 optional single-circuit units, contacts D-D2 control start-up of compressor A2.

SWITCH E — Contacts E-E1 provide a 40-second bypass of the oil pressure switch at start-up. If oil pressure does not build to the required minimum pressure in 40 seconds, the compressor shuts down and the control circuit locks out.

On 38AH044-084 dual-circuit and 38AH094,104 units, lag circuit B start-up is delayed 60 seconds after a call for cooling is made to the circuit. This prevents compressor(s) in both lead and lag circuits from starting at the same time.

Control Circuit Reset — The control circuit locks out if the unit shuts down because of low oil pressure, high discharge gas temperature (DGT), or excessive high-side pressure. To reset the control circuit, open and close the fan circuit breaker (FCB). This resets the timer, and the unit restarts under Time Guard control. At start-up, if the low-pressure switch (LPS) does not close after 2½ minutes, the unit shuts down. When the pressure builds enough for the LPS to cut in, the control circuit is energized automatically and start-up proceeds under Time Guard control.

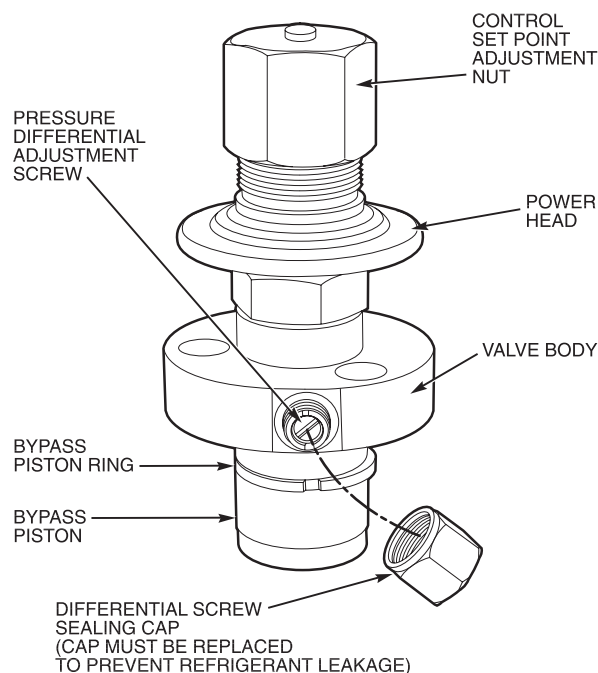


Fig. 46 — Pressure-Actuated Capacity Control Valve

CONTROL

Sequence of Operation — Units are controlled with electromechanical components. Each refrigeration circuit (except 38AH044-084 optional single-circuit units) is operated by an independent timer which controls the operation sequence of each circuit.

On a call for cooling, first stage cooling thermostat TC1 closes. Condenser fans and timer (TM) are energized. After approximately 7 seconds, timer contacts E-E1 close. Approximately 12 seconds after TC1 closes, normally-open timer contacts B-B1 close for 1 second. This energizes compressor A1 contacts CA1 and starts the compressor. At the same time, solenoid drop relays (SDRs) and liquid line solenoid valve no. 1 (LLS-A for 38AH044-084 dual-circuit units; LLS-A1 for all other units) open, and timer relay no. 1 (TR2) is energized. Normally open TR2 contacts close, completing a circuit around B-B1 and through compressor A1 contactors to maintain compressor operation when B-B1 contacts open. Contacts E-E1 remain closed for approximately 40 seconds to bypass the oil pressure switch (OPS). If oil pressure is insufficient when contacts E-E1 open, the compressor stops, the timer shuts down, and the control circuit locks out. At start-up, timer contacts D-D1 are closed, bypassing low-pressure relay contacts LPR-A for 2½ minutes. This provides a winter start-up feature.

Approximately 2½ minutes after TC1 closes, timer contacts D-D1 open and D-D2 close. If pressure is insufficient to close the low-pressure switch, the low-pressure switch relay is open, the compressor shuts down, and the Time Guard control is initiated. (Time Guard control prevents compressor from restarting for 5 minutes after the demand for cooling is satisfied.)

38AH044-084 DUAL-CIRCUIT UNITS; 38AH094,104 — If circuit A operation is insufficient for the cooling requirements, the thermostat second stage TC2 closes to bring circuit B on-line for cooling. This circuit follows the same sequence of operation as the lead circuit, except a 60-second time delay relay (TDR) delays compressor start-up for 60 seconds after the call for cooling.

38AH044-084 OPTIONAL SINGLE-CIRCUIT UNITS: MODULES 124A, 124B, 134A, AND 134B

NOTE: This sequence of operation assumes that 2 thermostats control units 38AH124 or 134 with one thermostat controlling each module.

If compressor A1 is insufficient for the cooling requirements, the thermostat second stage closes, which opens the liquid line solenoid valve LLS-A2. Compressor A2 starts only after D-D2 contacts in the timer close and the suction pressure is sufficient to close the capacity control switches.

ALL UNITS — When the fan switch is set for automatic (AUTO) operation, the indoor-fan contactor (IFC) is cycled with the lead compressor. If the fan switch is set for continuous (CONT), the IFC is energized as long as the unit power is on.

Restart After Stoppage by Safety Control — The high-pressure switch, compressor discharge gas thermostats, and the oil pressure switch must be reset manually by breaking the control power supply at any of the following points: control circuit fuse, fan motor circuit breaker, or the thermostat. Restart follows the Time Guard® control delay.

Stoppage by low-pressure switch results in Time Guard control delay, then unit attempts normal restart.

The compressor motor overcurrent protectors are manual-reset circuit breakers. Reset of control circuit may also be necessary.

Independent Refrigerant Circuit Controls — Each refrigeration circuit is controlled by independent circuitry. Therefore, it is possible to maintain partial cooling capability even if one compressor is inoperable.

NOTE: The 38AH044-084 optional single-circuit units do not have independent control circuitry.

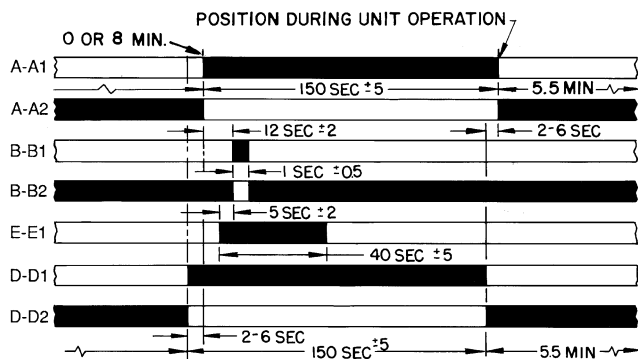


Fig. 47 — Timer Cycle

Unit Control Box — (See Fig. 48.) Viewed facing compressors, the control box is at left end of the unit. All incoming power enters through the control box. The control box contains power components and electronic controls. Outer panels are hinged and latched for easy opening. Remove screws to remove inner panels. Outer panels can be held open for service and inspection by using door retainer on each panel. Remove bottom pin from door retainer assembly, swing retainer out horizontally, and engage pin in one of the retainer ears and the hinge assembly.

Condenser Fans — Each fan is supported by a formed wire mount bolted to fan deck and covered with a wire guard. The exposed end of fan motor shaft is protected from weather by grease. If fan motor must be removed for service or replacement, be sure to regrease fan shaft, and reinstall fan guard. For proper performance, fan should be 7/8 in. (22 mm) below top of venturi on the fan deck to top of the fan hub for 60-Hz units, and 1/2 in. (13 mm) for 50-Hz units. (See Fig. 49.) Tighten set screws to 15 ± 1 ft-lbs (20 ± 1.3 N-m). Figure 49 shows proper position of mounted fan.

IMPORTANT: Check for proper fan rotation (clockwise viewed from above). If necessary to reverse, switch leads.

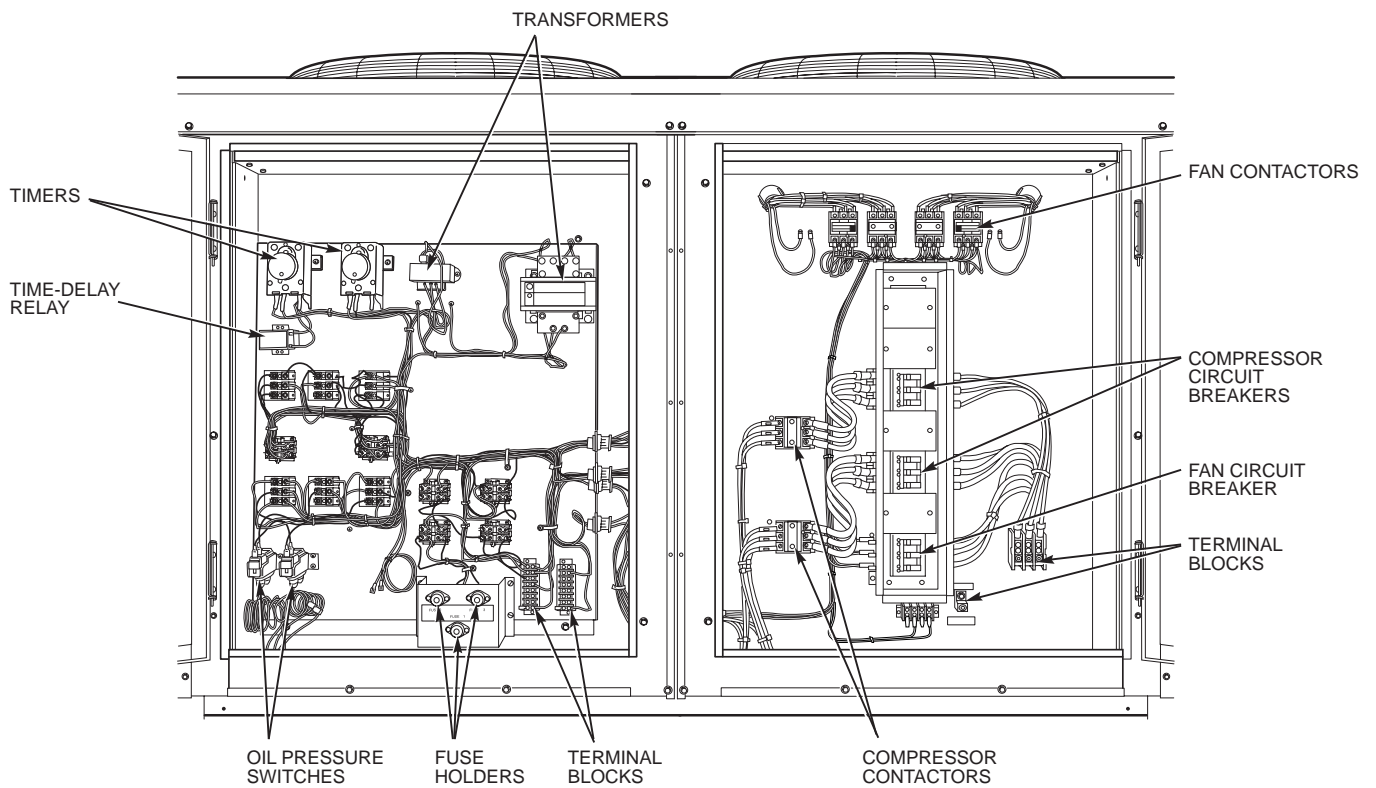
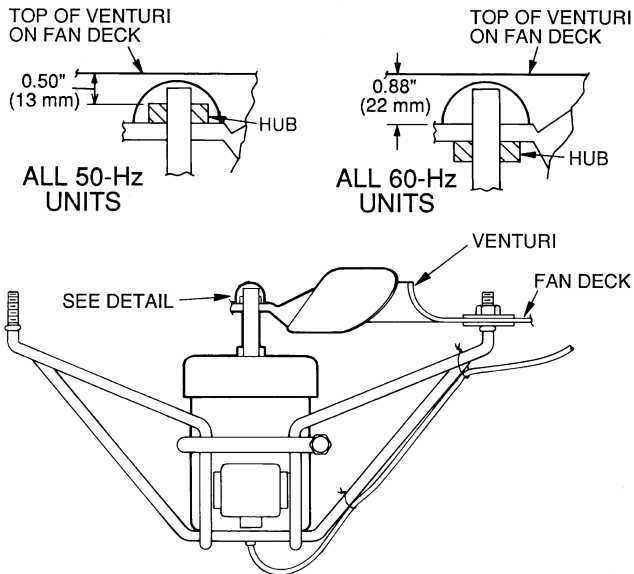


Fig. 48 — Unit Control Box



NOTE: Fan rotation is clockwise when viewed from top of unit.

Fig. 49 — Condenser Fan Adjustment

Required Compressor Modification for 38AH044-084 Optional Single-Circuit Units, When Compressor A1 is Out — To maintain unit operation, compressor no.1 must be operable. If it is not operable, the following *temporary* modifications must be made to keep the unit running:

1. Change the oil pressure switch connections from compressor A1 to compressor A2.
2. Connect compressor A2 into the Time Guard® circuit as compressor A1 was originally.
3. Open compressor A1 circuit breaker.

NOTE: Make sure the crankcase heaters are energized when compressors are off.

Compressor Removal — Access to the pump end of the compressor is from the compressor side of the unit. Access to the motor end of the compressor is from the inside of the unit. All compressors can be removed from the compressor side of the unit.

IMPORTANT: All compressor mounting hardware and support brackets removed during servicing must be re-installed prior to start-up.

1. Disconnect power to unit; lockout power to compressor.
2. Close suction and discharge service valves.
3. Relieve refrigerant pressure into a refrigerant recovery system.
4. Remove:
 - a. Fan-cycling pressure switch (FCPS)
 - b. High-pressure switch
 - c. Low-pressure switch
 - d. Oil-pressure switch
 - e. Discharge gas temperature switch.
5. Disconnect power wires at terminal box and disconnect conduit.
6. Disconnect wires from crankcase heater.
7. Disconnect service valves from compressor.
NOTE: On 38AH044-084 optional single-circuit units and units with 2 compressors per circuit, disconnect both oil equalizer lines located on the motor barrel and on the oil pump sump.
8. Units 38AH044-084, 124, and 134:
 - a. Remove 4 large screws securing compressor mounting pan to unit base rail.
 - b. Slide compressor (on mounting pan) to outside of unit frame; support and/or lower to ground.
 - c. Unbolt compressor from mounting pan and remove.
9. Units 38AH094, 104:
 - a. Remove 4 large screws securing compressor to the compressor rails.
 - b. Lift compressor off mounting bolts and remove.

Compressor Replacement — Perform the following:

1. Reverse procedure in Compressor Removal section to end of Step 4.
2. Reinstall service valves and safety switches, and tighten to torques as listed:

| <u>Torque</u> | <u>Compressor(s)</u> |
|---|---|
| Tighten discharge valves to — | |
| 20-25 ft-lbs (27- 34 N-m) | 06E-250 |
| 80-90 ft-lbs (109-122 N-m) | 06E-265,275,299 |
| Tighten suction valves to — | |
| 80- 90 ft-lbs (109-122 N-m) | 06E-250 |
| 90-120 ft-lbs (122-163 N-m) | 06E-265,275,299 |
| Tighten the following fittings as specified — | |
| 60 ft-lbs (81 N-m) | Discharge Gas Thermostat |
| 120 in.-lbs (13.5 N-m) | High-Pressure Switch, Fan-Cycling Pressure Switch |
| 120 in.-lbs (13.5 N-m) | Low-Pressure Switch |

3. Leak-check and evacuate system, reclaim refrigerant.
4. Recharge system per pre-start-up and start-up sequences. Recheck oil levels.
5. Energize crankcase heater for 24 hours prior to restart of system.

OIL CHARGE — (Refer to Table 3A, 3B, 4A, or 4B.) All units are factory charged with oil. Acceptable oil level for each compressor is from 1/8 to 1/3 of sight glass (see Fig. 29, page 38).

When additional oil or a complete charge is required, use only Carrier-approved compressor oil.

Approved oils are:

- Petroleum Specialties, Inc. — Cryol 150A (factory oil charge)
- Texaco, Inc. — Capella WF-32-150
- Witco Chemical Co. — Suniso 3GS

| COMPRESSOR | OIL REQUIRED | |
|----------------|--------------|-----|
| | Pts | L |
| 06E-250 | 17 | 8.0 |
| 06E-265 | 21 | 9.9 |
| 06E-275 | 21 | 9.9 |
| 06E-299 | 19 | 9.0 |

Do not reuse drained oil, and do not use any oil that has been exposed to atmosphere.

Adjust oil level in accordance with Start-Up, Preliminary Oil Charge, page 38.

TROUBLESHOOTING

| PROBLEM | SOLUTION |
|---|--|
| <p>COMPRESSOR DOES NOT RUN</p> <p><u>Contactors Open</u></p> <ol style="list-style-type: none"> 1. Power off. 2. Fuses blown in field power circuit. 3. No control power. 4. Thermostat circuit open. 5. Multi-function timer not operating. 6. Compressor circuit breaker tripped. 7. Safety device lockout circuit active. 8. Low-pressure switch open. 9. High-pressure switch open. 10. Discharge gas temperature switch open. 11. Loose electrical connections. 12. Compressor stuck. <p><u>Contactors Closed</u></p> <ol style="list-style-type: none"> 1. Compressor leads loose. 2. Motor windings open. 3. Single phasing. | <ol style="list-style-type: none"> 1. Restore power. 2. After finding cause and correcting, replace with correct size fuse. 3. Check secondary fuse(s); replace with correct type and size. Replace transformer if primary windings receiving power. 4. Check thermostat setting. 5. Check timer for proper operation; replace if defective. 6. Check for excessive compressor current draw. Reset breaker; replace if defective. 7. Reset lockout circuit at thermostat or circuit breaker. 8. Check for refrigerant undercharge, obstruction of indoor airflow, or whether compressor suction shutoff valve is fully open. Make sure liquid line solenoid valve(s) is open. 9. Check for refrigerant overcharge, obstruction of outdoor airflow, air in system or whether compressor discharge valve is fully open. Be sure outdoor fans are operating correctly. 10. Check for open condition. Allow for reset. Replace if defective. 11. Tighten all connections. 12. See 06E compressor service literature. <ol style="list-style-type: none"> 1. Check connections. 2. See 06E compressor service literature. 3. Check for blown fuse. Check for loose connection at compressor terminal. |
| <p>COMPRESSOR STOPS ON HIGH-PRESSURE SWITCH</p> <p><u>Outdoor Fan On</u></p> <ol style="list-style-type: none"> 1. High-pressure switch faulty. 2. Airflow restricted. 3. Air recirculating. 4. Noncondensables in system. 5. Refrigerant overcharge. 6. Line voltage incorrect. 7. Refrigerant system restrictions. <p><u>Outdoor Fan Off</u></p> <ol style="list-style-type: none"> 1. Fan slips on shaft. 2. Motor not running. 3. Motor bearings stuck. 4. Motor overload open. 5. Motor burned out. | <ol style="list-style-type: none"> 1. Replace switch. 2. Remove obstruction. 3. Clear airflow area. 4. Purge and recharge as required. 5. Purge as required. 6. Consult power company. 7. Check or replace filter drier, expansion valve, etc. Check that compressor discharge valve is fully open. <ol style="list-style-type: none"> 1. Tighten fan hub setscrews. 2. Check power and capacitor. 3. Replace bearings. 4. Check overload rating. Check for fan blade obstruction. 5. Replace motor. |
| <p>COMPRESSOR CYCLES ON LOW-PRESSURE SWITCH</p> <p><u>Indoor-Air Fan Running</u></p> <ol style="list-style-type: none"> 1. Filter drier plugged. 2. Expansion valve power head defective. 3. Low refrigerant charge. <p><u>Airflow Restricted</u></p> <ol style="list-style-type: none"> 1. Coil iced up. 2. Coil dirty. 3. Air filters dirty. 4. Dampers closed. <p><u>Indoor-Air Fan Stopped</u></p> <ol style="list-style-type: none"> 1. Electrical connections loose. 2. Fan relay defective. 3. Motor overload open. 4. Motor defective. 5. Fan belt broken or slipping. | <ol style="list-style-type: none"> 1. Replace filter drier. 2. Replace power head. 3. Add charge. Check low-pressure switch setting. <ol style="list-style-type: none"> 1. Check refrigerant charge. 2. Clean coil fins. 3. Clean or replace filters. 4. Check damper operation and position. <ol style="list-style-type: none"> 1. Tighten all connections. 2. Replace relay. 3. Power supply. 4. Replace motor. 5. Replace or tighten belt. |

TROUBLESHOOTING (cont)

| PROBLEM | SOLUTION |
|--|---|
| COMPRESSOR STOPS ON OIL PRESSURE SWITCH <ol style="list-style-type: none"> 1. Oil level too low or too high. 2. Compressor is short cycling. 3. Crankcase heater off. 4. Low refrigerant charge. 5. Refrigerant floodback. 6. Evaporator coil is blocked or iced. 7. Evaporator fan not operating. 8. Distributor and/or TXV too large. 9. Suction riser too large. 10. Defective oil pressure switch. 11. Plugged oil pump inlet screen. 12. Faulty oil pump drive segment. 13. Worn oil pump. 14. Worn compressor bearings. | <ol style="list-style-type: none"> 1. Check oil level requirements; adjust oil level until sight glass is filled $\frac{1}{8}$ to $\frac{1}{3}$ when running. 2. Check for <ol style="list-style-type: none"> a) Thermostat location and operation. b) Safety device lockout circuit operation. c) End-of-cycle control and timer operation. d) Low-pressure switch and relay operation. 3. Check relay operation; replace crankcase heater(s), if defective. 4. Adjust charge as required. 5. Adjust TXV superheat. 6. Check and correct as required. 7. Check and correct as required. 8. Check sizing at design conditions; change if incorrect for current application. 9. Check line sizing at minimum design condition; change piping if incorrect. 10. Check switch for proper operation; check capillary lines for plugged lines. 11. Clean oil pump screen. 12. Replace drive segment. 13. Replace bearing head assembly. 14. Replace compressor; see 06E service instructions. |
| COMPRESSOR RUNNING BUT COOLING INSUFFICIENT Suction Pressure Low <ol style="list-style-type: none"> 1. Refrigerant charge low. 2. Head pressure low. 3. Air filters dirty. 4. Expansion valve power head defective. 5. Indoor coil partially iced. 6. Indoor airflow restricted. Suction Pressure High <ol style="list-style-type: none"> 1. Unloaders not functioning. 2. Compressor valve defective. 3. Heat load excessive. | <ol style="list-style-type: none"> 1. Add refrigerant. 2. Check refrigerant charge. Check outdoor-air fan thermostat settings. 3. Clean or replace filters. 4. Replace power head. 5. Check low-pressure setting. 6. Remove obstruction. <ol style="list-style-type: none"> 1. Check unloader adjustments. Check unloader setting. 2. See 06E compressor service literature. 3. Check for open doors or windows in vicinity of fan coil. |
| UNIT OPERATES TOO LONG OR CONTINUOUSLY <ol style="list-style-type: none"> 1. Low refrigerant charge. 2. Control contacts fused. 3. Air in system. 4. Partially plugged expansion valve or filter drier. | <ol style="list-style-type: none"> 1. Add refrigerant. 2. Replace control. 3. Purge and evacuate system. 4. Clean or replace. |
| SYSTEM IS NOISY <ol style="list-style-type: none"> 1. Piping vibration. 2. Compressor noisy. | <ol style="list-style-type: none"> 1. Support piping as required. 2. Check valve plates for valve noise. Replace compressor if bearings are worn. |
| COMPRESSOR LOSES OIL <ol style="list-style-type: none"> 1. Leak in system. 2. Crankcase heaters not energized during shutdown. 3. Improper interconnecting piping design. | <ol style="list-style-type: none"> 1. Repair leak. 2. Check wiring and relays. Check heater and replace if defective. 3. Check piping for oil return. Replace if necessary. |
| FROSTED SUCTION LINE <ol style="list-style-type: none"> 1. Expansion valve admitting excess refrigerant. | <ol style="list-style-type: none"> 1. Adjust expansion valve. |
| HOT LIQUID LINE <ol style="list-style-type: none"> 1. Shortage of refrigerant due to leak. 2. Expansion valve opens too wide. | <ol style="list-style-type: none"> 1. Repair leak and recharge. 2. Adjust expansion valve. |
| FROSTED LIQUID LINE <ol style="list-style-type: none"> 1. Restricted filter drier. | <ol style="list-style-type: none"> 1. Remove restriction or replace. |
| COMPRESSOR WILL NOT UNLOAD <ol style="list-style-type: none"> 1. Defective unloader. 2. Defective capacity control solenoid valve (if used). 3. Miswired capacity control liquid line solenoid (if used). 4. Weak, broken, or wrong valve body spring. | <ol style="list-style-type: none"> 1. Replace unloader. 2. Replace valve. 3. Rewire correctly. 4. Replace spring. |
| COMPRESSOR WILL NOT LOAD <ol style="list-style-type: none"> 1. Miswired capacity control liquid line solenoid (if used). 2. Defective capacity control solenoid valve (if used). 3. Plugged strainer (high side). 4. Stuck or damaged unloader piston or piston ring(s). | <ol style="list-style-type: none"> 1. Rewire correctly. 2. Replace valve. 3. Clean or replace strainer. 4. Clean or replace the necessary parts. |

START-UP CHECKLIST

A. Preliminary Information

OUTDOOR: MODEL NO. _____ SERIAL NO. _____
INDOOR: AIR HANDLER MANUFACTURER _____
MODEL NO. _____ SERIAL NO. _____
ADDITIONAL ACCESSORIES _____

B. Pre-Start-Up

OUTDOOR UNIT

IS THERE ANY SHIPPING DAMAGE? _____ (Y/N) _____
IF SO, WHERE: _____

WILL THIS DAMAGE PREVENT UNIT START-UP? (Y/N) _____
CHECK POWER SUPPLY. DOES IT AGREE WITH UNIT? (Y/N) _____
HAS THE GROUND WIRE BEEN CONNECTED? (Y/N) _____
HAS THE CIRCUIT PROTECTION BEEN SIZED AND INSTALLED PROPERLY? (Y/N) _____
ARE THE POWER WIRES TO THE UNIT SIZED AND INSTALLED PROPERLY? (Y/N) _____
HAVE COMPRESSOR HOLDDOWN BOLTS BEEN LOOSENEED? (Y/N) _____

CONTROLS

ARE THERMOSTAT(S) AND INDOOR FAN CONTROL WIRING CONNECTIONS MADE AND CHECKED? (Y/N) _____
ARE ALL WIRING TERMINALS (including main power supply) TIGHT? (Y/N) _____
HAVE CRANKCASE HEATERS BEEN ENERGIZED FOR 24 HOURS? (Y/N) _____

INDOOR UNIT

HAS WATER BEEN PLACED IN DRAIN PAN TO CONFIRM PROPER DRAINAGE? (Y/N) _____
ARE PROPER AIR FILTERS IN PLACE? (Y/N) _____
HAVE FAN AND MOTOR PULLEYS BEEN CHECKED FOR PROPER ALIGNMENT? (Y/N) _____
DO THE FAN BELTS HAVE PROPER TENSION? (Y/N) _____

PIPING

ARE LIQUID LINE SOLENOID VALVES LOCATED AT THE EVAPORATOR COILS AS REQUIRED? (Y/N) _____
HAVE LEAK CHECKS BEEN MADE AT COMPRESSORS, CONDENSERS, EVAPORATORS, TXVs (Thermostatic Expansion Valves) SOLENOID VALVES, FILTER DRIERS, AND FUSIBLE PLUGS WITH A LEAK DETECTOR? (Y/N) _____
LOCATE, REPAIR, AND REPORT ANY LEAKS. _____
HAVE ALL COMPRESSOR SERVICE VALVES BEEN FULLY OPENED (BACKSEATED)? (Y/N) _____
ARE THE COMPRESSOR OIL SIGHT GLASSES SHOWING ABOUT 1/2 FULL? (Y/N) _____

CHECK VOLTAGE IMBALANCE

LINE-TO-LINE VOLTS: AB _____ V AC _____ V BC _____ V
 $(AB + AC + BC)/3 = \text{AVERAGE VOLTAGE} = \text{_____ V}$
MAXIMUM DEVIATION FROM AVERAGE VOLTAGE = _____ V
VOLTAGE IMBALANCE = $100 \times (\text{MAX DEVIATION})/(\text{AVERAGE VOLTAGE}) = \text{_____ \%}$

IF OVER 2% VOLTAGE IMBALANCE, DO NOT ATTEMPT TO START SYSTEM!
CALL LOCAL POWER COMPANY FOR ASSISTANCE.

