

# Roll Filter Sections

## Central Station Air-Handling Units

### INDEX

INSTALLATION	Page	START-UP	Page
Step 1 — Verify Shipment with Shipping Order .....	1	Step 8 — Perform Electrical Control System Checkout .....	9
Step 2 — Rig Roll Filter Section .....	1	<b>SERVICE</b>	
Step 3 — Suspend Roll Filter Section .....	1	Replacing Dirty Filter Media .....	10
Step 4 — Make Airway Connection .....	1	Media Runout Switch .....	10
Step 5 — Review RFS Components .....	1	Pressure Switch.....	11
Step 6 — Install Power and Control Wires ...	1	Motor Gear-Drive Assembly .....	11
Step 7 — Install Roll Filter Media .....	8	Media Tension Brake.....	11
		Shear Pin.....	11
		Cleaning and Lubrication .....	11

### INSTALLATION

**Step 1 — Verify shipment with Shipping Order** — Roll filter sections (RFS) are designed to be bolted to standard Carrier 39E Central Station Air-Handling Unit section without modification. They may also be installed in field-fabricated duct systems. Sections are identified as:

MODEL NO.*	APPLICATION	V-PH-HZ	AMPS	HP
39ER_A (RFS1)	Outdoor, Automatic	120-1-60	3.2	1/10
39ED_B (RFS1)	Indoor, Automatic			
39ED_C (RFS3)	Indoor, Manual			
39ER_D (RFS5)	Outdoor, Automatic	230-1-50	16	1/10
39ED_E (RFS5)	Indoor, Automatic			
39ED_F (RFS7)	Indoor, Manual			

\*Sizes available for each model are shown in Fig. 3

If shipment is incomplete, contact Carrier. File damage claims with transportation agency.

**Step 2 — Rig Roll Filter Section** — Section is designed for overhead rigging only. Do not remove shipping skids until RFS is ready to be moved to final location. Whenever RFS is moved, use slings and spreader bars to prevent damage to enclosure (Fig. 1). Brackets on entering air end of section are for suspension and are not to be used for rigging. Refer to base unit installation instructions as required.

**Step 3 — Suspend Roll Filter Section** — Sections are supplied with suspension brackets on air inlet end of channel leg supports (Fig. 1). Unit sizes 08 thru 57 may be suspended by these brackets and by downstream component bolted to outlet flange. Size 90 may not be suspended.

**Step 4 — Make Airway Connection** — Holes in RFS flanges match holes in 39E base unit sections. Assemble sections using fasteners shipped in cloth

bag in RFS. For outdoor installation, apply black caulking gasket on inlet and outlet flanges. Gasket is shipped in RFS.

**Step 5 — Review RFS Components** — Familiarize installer with RFS interior before proceeding with installation of power wiring and filter media roll. This simplifies installation and prevents damage to equipment. Refer to Fig. 2 thru 5.

**Step 6 — Install Power and Control Wires** — Junction box is located on right-hand side of RFS as shown in Fig. 2 and 3. Install a separate field-supplied power disconnect. On 39ER roof-curved units, route wires internally. Install all outdoor wiring in accordance with local codes. Connect to pigtails L1 and L2 provided. Also connect green ground wire found in junction box.

*Text continued on page 8*

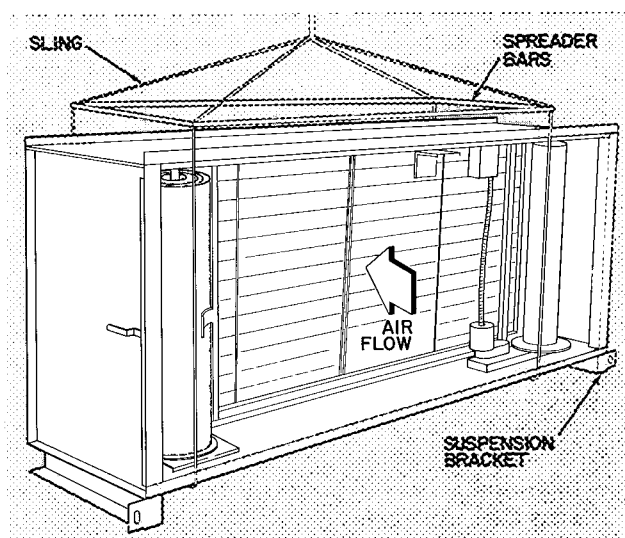
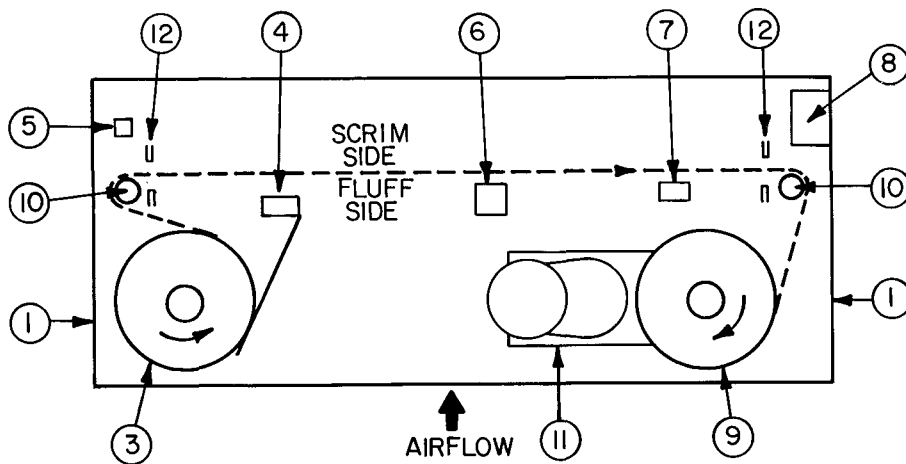
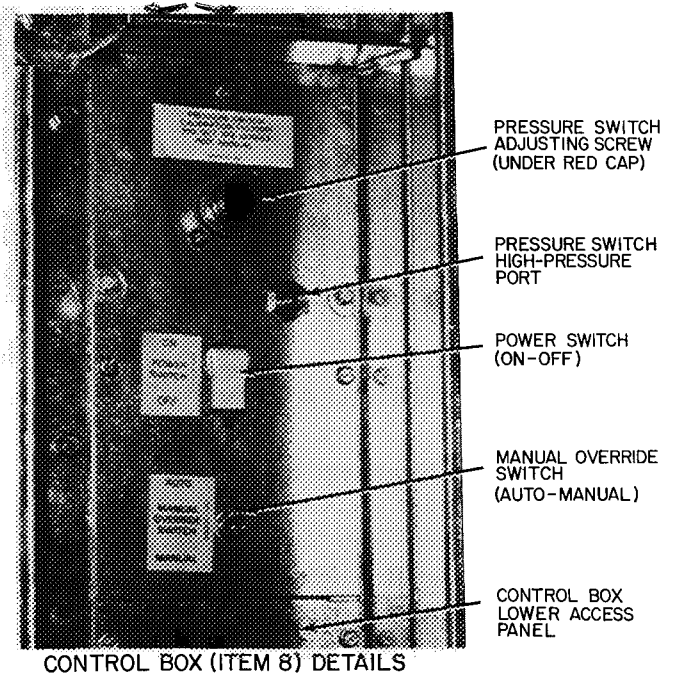
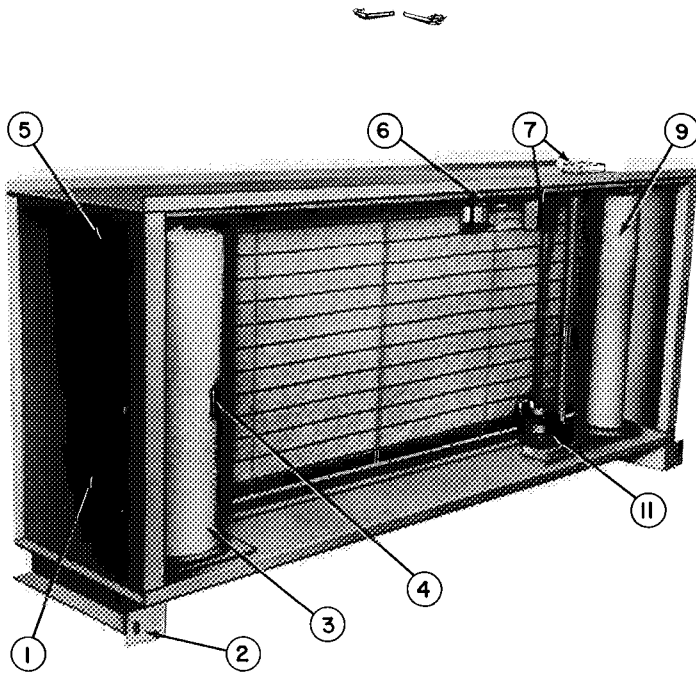

Fig. 1 — Rigging Details



LEGEND

- |                              |  |                                |
|------------------------------|--|--------------------------------|
| 1 — Access Door (both sides) | 6 — Pulse Generator Switch                   | 11 — Motor Gear Drive Assembly |
| 2 — Suspension Bracket       | 7 — Junction Box (position varies; see text) | 12 — Seal (both sides)         |
| 3 — Supply Spool Assembly    | 8 — Control Box                              | ---                            |
| 4 — Media Runout Switch      | 9 — Take-Up Spool Assembly                   | --- Media Path                 |
| 5 — Media Switch             | 10 — Idler Shaft (both sides)                |                                |

Fig. 2 — Roll Filter Section, RFS1 Shown

**ROLL FILTER SECTION DESCRIPTION** (Fig. 2 and 3) — All sections have side access doors having safety latches. A 1/4-in. x 20 bolt prevents door latch from opening unless bolt is removed. (Do not operate air system when any access door is open. Be sure to replace safety bolt after doors are closed.) Left-hand door provides access to roll media supply spool and a media switch. Right-hand side of section, in addition to take-up spool and its motorized gear drive, contains also a control panel, a field wiring junction

box, and where applicable, an indicator light box for remote mounting.

The 65-ft of roll media advance from left to right as shown. Media is monitored by a runout switch and a metering device for full span media travel. Replacement rolls of filter media (65-ft) may be shipped with section for future use. Largest model (39E-90) consists of 2 roll media assemblies in a common enclosure. Upper assembly (slave) is coupled to lower assembly for tandem operation by a common control/drive arrangement.

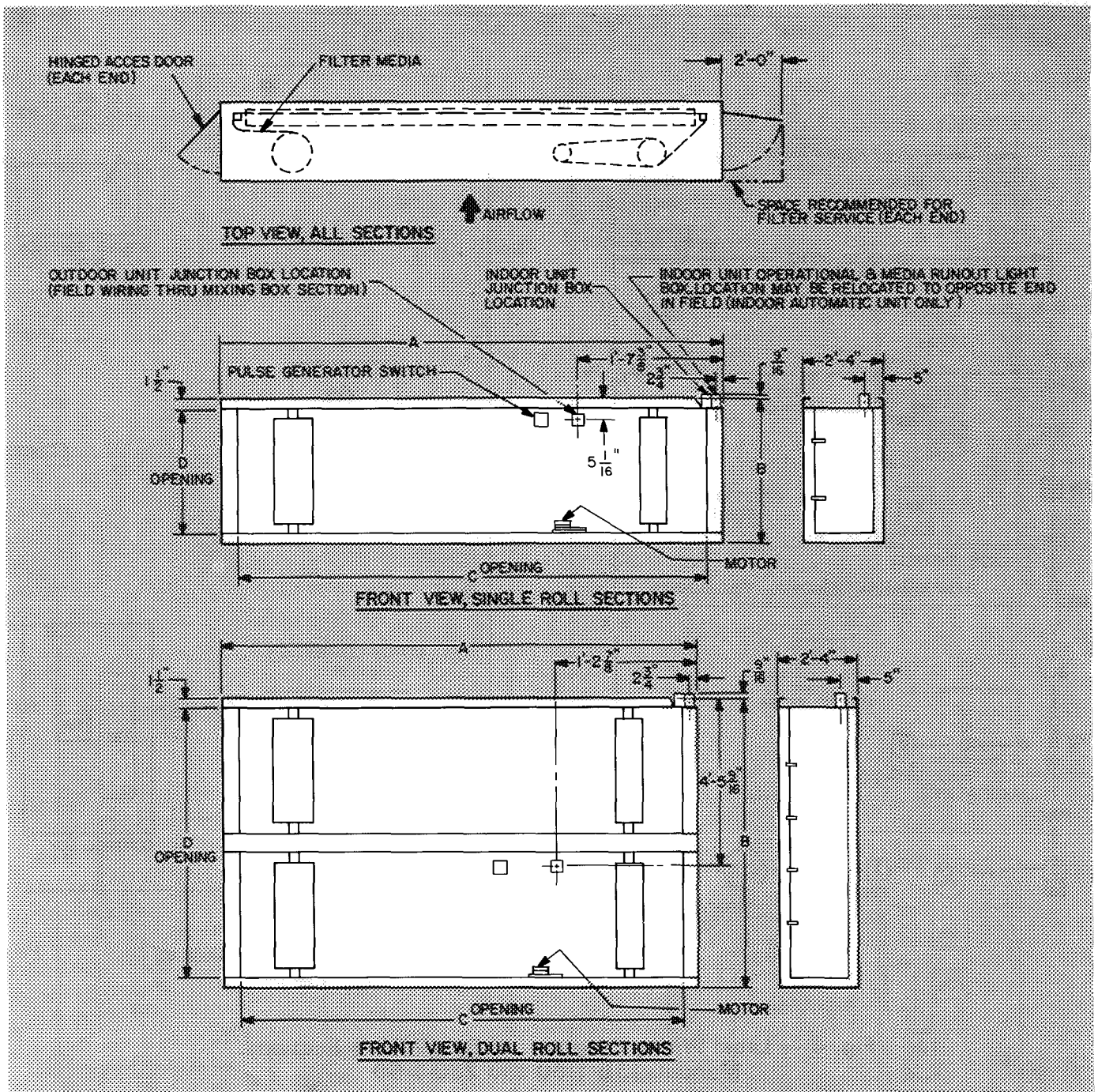

**SINGLE-MEDIA ROLL SECTIONS**

MODEL SIZE		FILTER AREA (sq ft)	CAPACITY (cfm)		WEIGHT (lbs, approx)	MEDIA ROLL HEIGHT (ft-in.)	ROLL FILTER SECTION DIMENSIONS (ft-in.)				FILTER FACE AREA (sq ft)
RFS	39E		500 FPM	600 FPM			A	B	C	D	
08	08	100	5,000	6,000	305	1-11-1/2	5-11	2-7	5-5-3/4	2-4	100
12	10,12	116	5,810	6,960	330	1-11-1/2	6-9	2-7	6-3-3/4	2-4	116
18	15,18	195	9,750	11,700	375	2-10-1/2	7-7	3-6	7-1-3/4	3-3	195
21	21	214	10,700	12,840	400	2-10-1/2	8-3	3-6	7-9-3/4	3-3	214
26	26	273	13,800	16,560	440	3-8	8-3	4-3-1/2	7-9-3/4	4-0-1/2	276
32	32	328	16,550	19,860	490	3-8	9-9	4-3-1/2	9-3-3/4	4-0-1/2	331
39	39	432	21,600	25,920	510	4-10	9-9	5-5-1/2	9-3-3/4	5-2-1/2	432
57	48,57	62.0	31,000	37,200	630	5-8	11-9	6-3-1/2	11-3-3/4	6-0-1/2	62.0

**DOUBLE-MEDIA ROLL SECTIONS**

90	75,90	91.2	46,100	55,320	825	3-8	13-3	8-4	12-9-3/4	8-1	92.2
----	-------	------	--------	--------	-----	-----	------	-----	----------	-----	------

RFS — Roll Filter Sections

**Fig. 3 — Physical Data and Dimensions, 39E Roll Filter Sections**

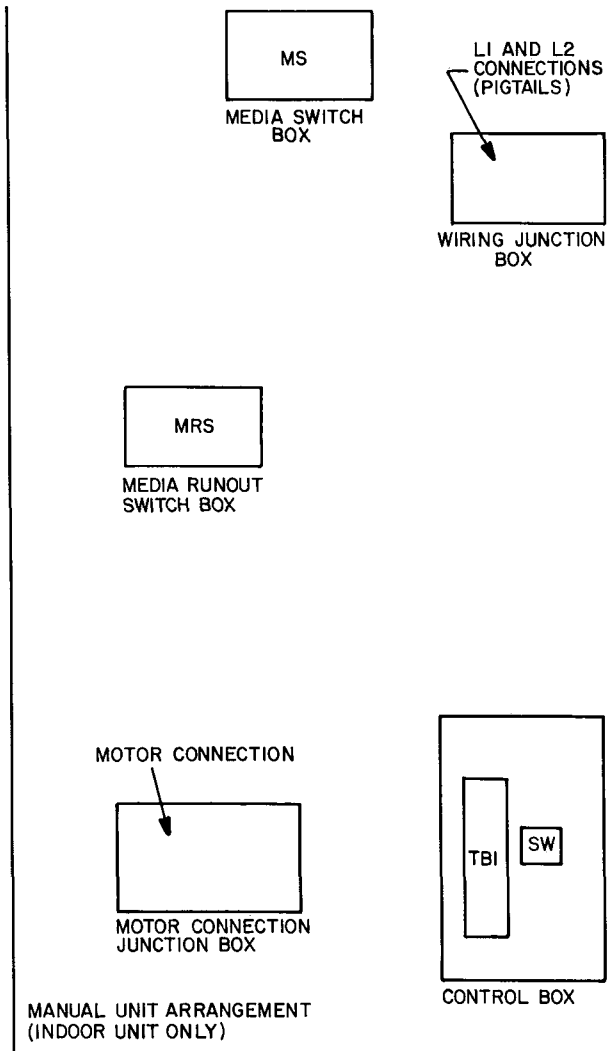
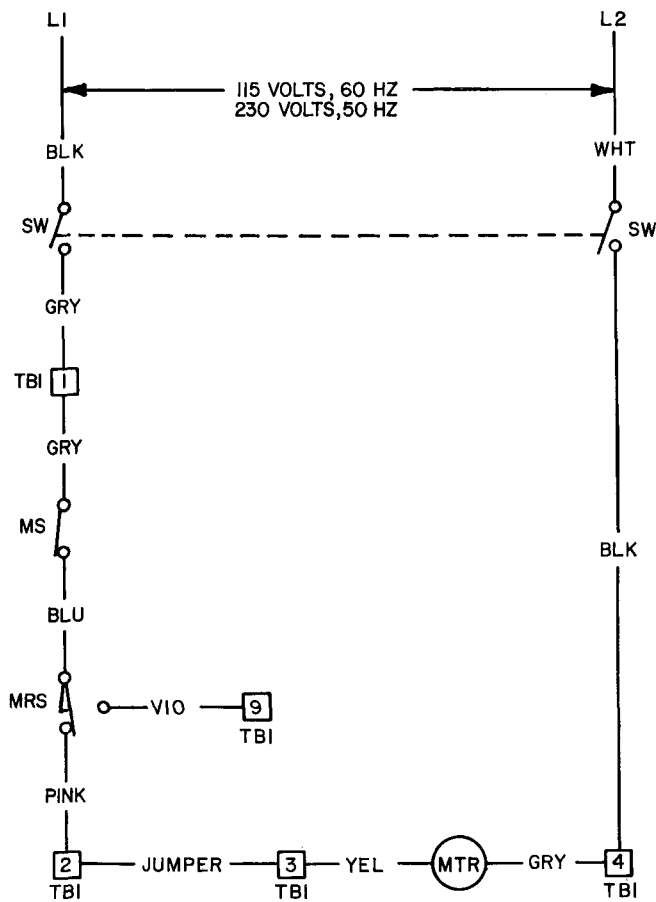

LABEL DIAG NO.  
 60Hz 3INC20-1064  
 50Hz 3INC 20-1074

**Fig. 4 — Label Wiring Diagram, 39E Roll Filter Sections,  
 Manual, 115-1-60 and 230-1-50**

**LEGEND**

(Fig. 4 and Fig. 5)

- IL — Indicating Light
- MOS — Manual Override Switch
- MRS — Media Runout Switch
- MS — Media Switch
- MTR — Motor
- OL — Operating Light
- PGS — Pulse Generator Switch
- PS — Pressure Switch
- SR — Sequence Relay
- SW — On-Off (Power) Switch
- TB — Terminal Board

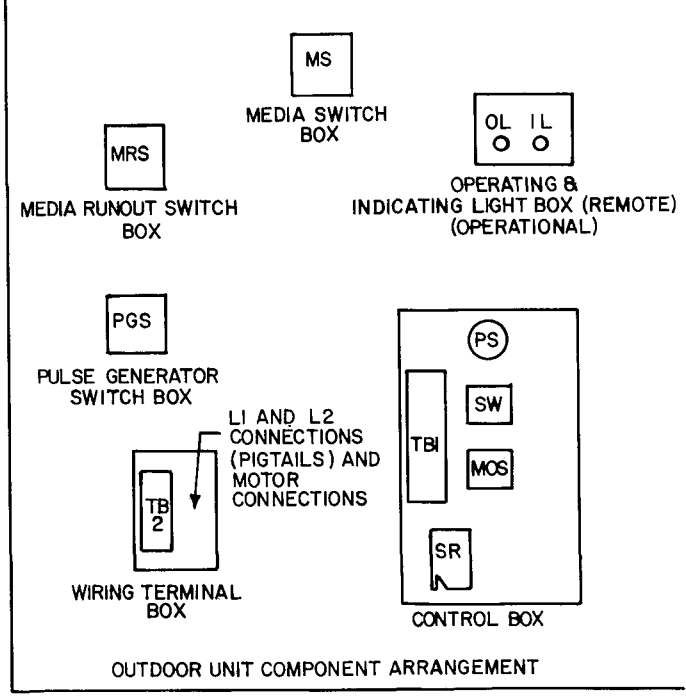
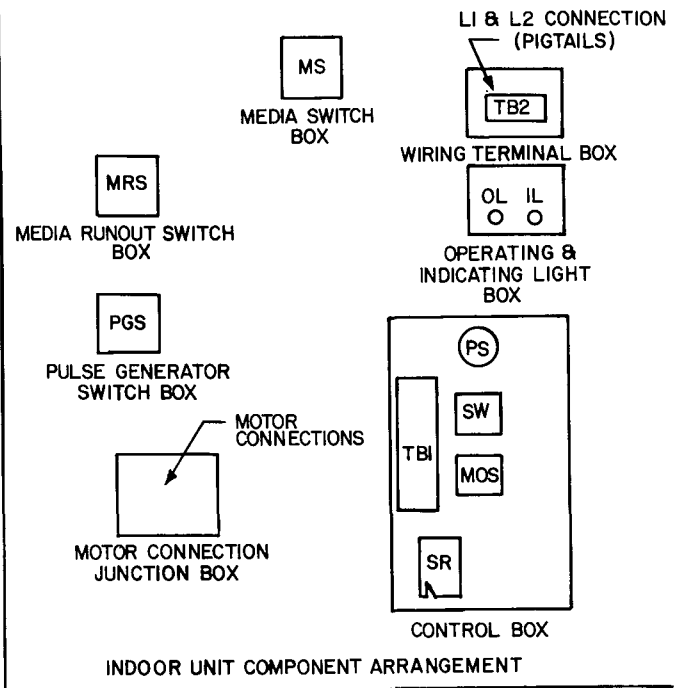
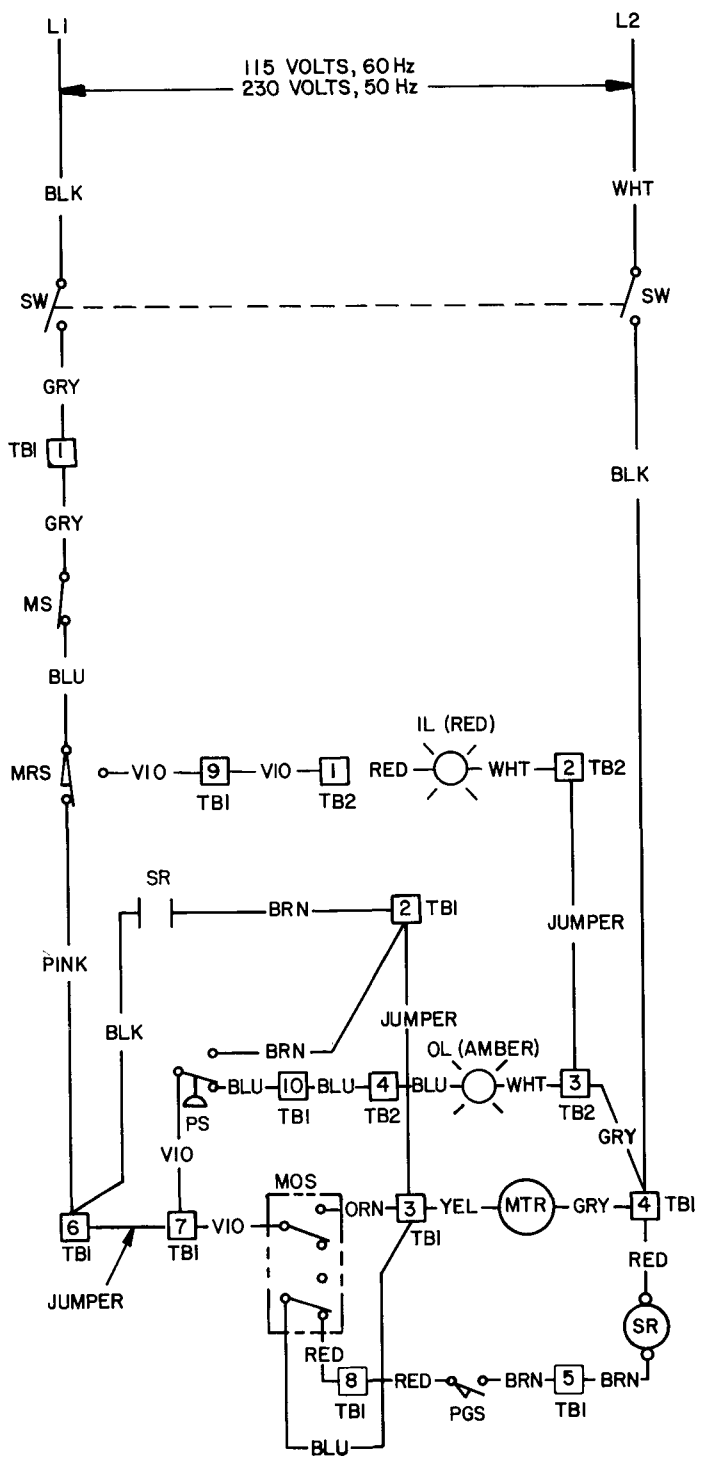

LABEL DIAG NO  
60 Hz 3INC20-1044  
50 Hz 3INC20-1054

Fig. 5 — Label Wiring Diagram, 39E Roll Filter Sections, Automatic, 115-1-60 and 230-1-50

## ELECTRICAL COMPONENT IDENTIFICATION (Fig. 4, 5, 6)

**Indicating Light (IL)** — Media runout light, automatic sections only. Red, activated by media runout switch. Illuminates when filter media on supply spool is depleted.

**Manual Override Switch (MOS)** — Overrides automatic advance circuit, activates motor circuit to permit manual motorized media advancement such as during media threading operation.

**Media Runout Switch (MRS)** — Prevents operation of gear motor when supply spool media is depleted. Activates red indicating light.

**Media Switch (MS)** — De-energizes motor circuit. Allows motor operation from supply side. Used in conjunction with manual override switch.

**Motor (MTR)** — Operates take-up spool gear drive to advance filter media. Thermally-protected, 6-rpm, 1/10-hp. Gear drive reduces take-up spool speed to 3 rpm.

**Operating Light (OL)** — Automatic sections only. Amber, indicates that control switches are in correct mode. Light goes out momentarily when pressure switch activates motor circuit. If electrical or mechanical malfunction occurs, light goes out and stays out to indicate possible power failure or that pressure drop thru airway exceeds air pressure switch setting due to mechanical failure. Light is re-energized when pressure or power is restored.

**Pulse Generator Switch (PGS)** — Automatic sections only, activated by media metering wheel cam to operate sequence relay.

**Pressure Switch (PS)** — Automatic sections only. Senses pressure drop thru media in airway. At preset pressure (0.55 in. wg factory setting, adjustable) it activates motor circuit (amber operating light goes out). When pressure drops below setting, switch returns to turn on operating light.

**Sequence Relay (SR)** — Automatic sections only. A holding relay that maintains motor operating

circuit. Senses pulses generated by pulse generator switch to advance ratchet cam shaft.

**On-Off Switch (SW)** — Power switch. Controls all power to motor and control circuit (DPST).

**Terminal Board (TB)** — Provides quick-connect terminals for indicator lights or other field-connected components.

**Pulse Generator Assembly (Fig. 6)** — Consists of media metering wheel, pulse generator switch and sequence relay. Except for making sure that media metering wheel tension against media is sufficient to turn wheel as media passes by, little or no service can be performed beyond keeping media metering wheel and shaft free of lint and making sure that electrical connections are intact. The assembly functions as follows:

As air pressure increases due to restriction caused by dirty filter media, pressure switch closes activating motor to advance media. Media passing metering wheel causes wheel to turn. Eccentric closes pulse generator switch which momentarily energizes sequence relay once each revolution. Sequence relay arm advances ratchet wheel one notch causing relay switch arm cam follower to ride up out of valley. Sequence relay contacts on relay switch arm close maintaining power to motor. As media metering wheel continues to trip sequence relay, pulses advance ratchet until cam follower drops into valley thus de-energizing motor power. Media advancement ceases. Valley-to-valley interval, which depends on media metering wheel diameter and number of valleys, is "programmed" to operate motor so that a pre-determined length of media is advanced into airway for full span operation. Ratchet and cam may be advanced manually (clockwise) by either turning cam or repeatedly pressing on sequence coil arm such as when operational check requires manual advance.

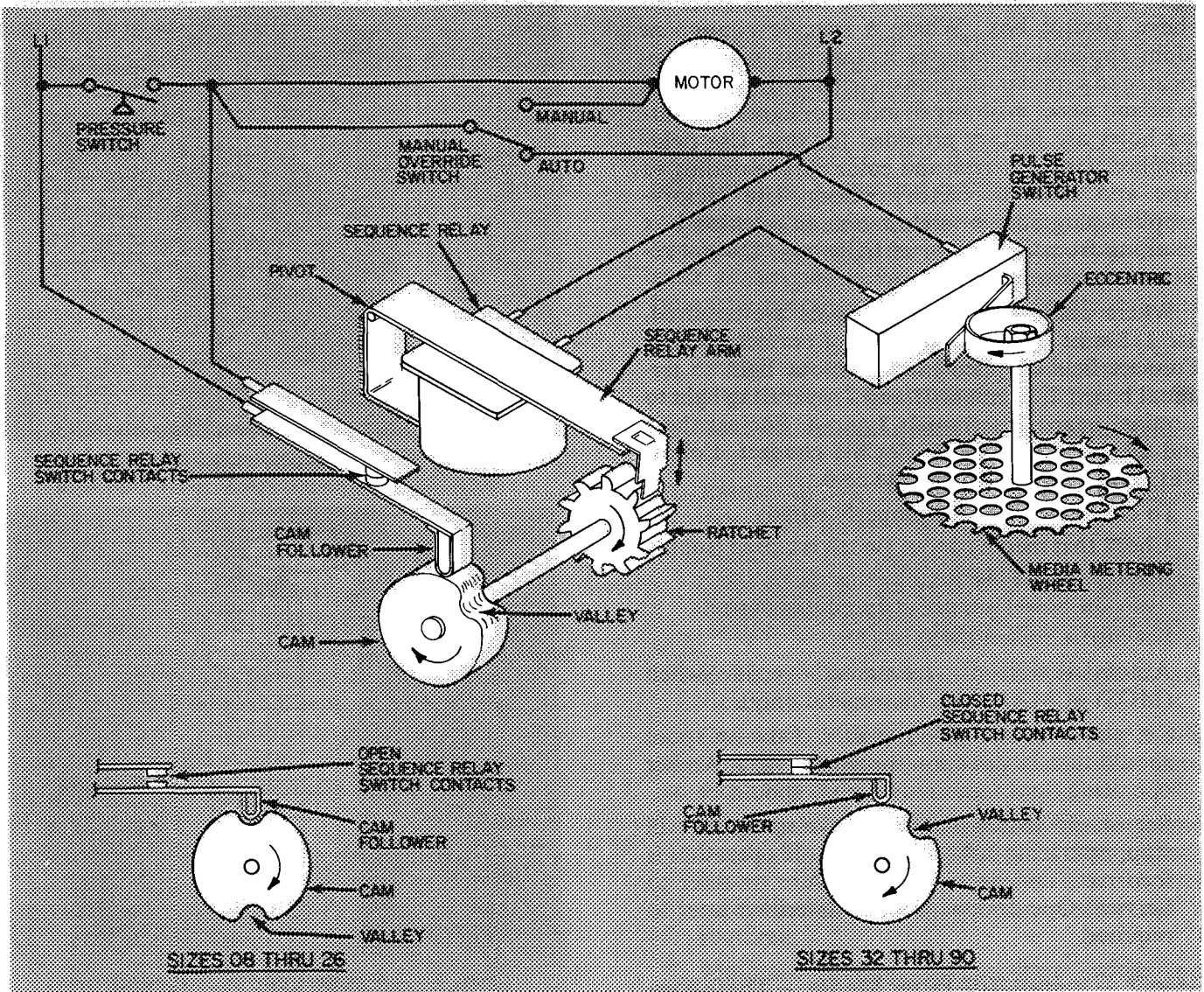

Fig. 6 — Pulse Generator Assembly,  
Symbolic Diagram

Text continued from page 1.

Install remote indicator light box shipped with outdoor automatic sections per job plans. Indicator light box on indoor automatic units is fastened above control box. Where a specific equipment room application requires it, this box may be relocated to a similar location on left-hand end of RFS to permit easier visibility of indicator lights. Mounting holes are factory provided for this. Use field-supplied wiring of type and color corresponding to type and color of factory wiring. Use factory-supplied plug button to close hole in junction box resulting from relocation of light box. Do not relocate junction box.

Where additional indicator lights are required, use 1/2-watt (maximum) lights of correct voltage. Connect field-supplied media runout light to terminal board 2, terminals 1 and 2; operating light to terminal board 2, terminals 3 and 4. Enclose these and all wires in rigid or flexible conduit. Follow NEC and all other applicable codes.

To check that RFS is properly wired:

1. Check that media runout switch is closed (supply media roll in place).
2. Turn on power supply at fused disconnect.
3. Set media switch (MS) at ON.
4. Automatic section — set manual override switch (MOS) at MANUAL (automatic only).
5. Set power switch (SW) at ON. Take-up spool should turn in direction shown in Fig. 2. Amber operating light (automatic units) should be on.
6. Set on-off switch at OFF. Take-up spool will stop; operating light will go out. If operation is incorrect, review wiring procedure or refer to Service, Operational Checks described later as required.

**Step 7 — Install Roll Filter Media** — The following procedure applies to installation of initial roll filter media as shipped with section. If replacing dirty filter media, refer to section entitled Replacing Dirty Filter Media.

1. Open take-up side access door. Set power switch at OFF, set manual override switch at MANUAL (Fig. 2). Open supply side access door. Set media switch at ON.
2. Begin with lower assembly on dual roll sections. Lift supply spool shaft upper retainer, swing out upper end of spool shaft.
3. Install media roll on spool shaft. Note correct position of roll so that as media unwinds, fluff side of media will be facing into airstream (Fig. 2).
4. Untie and remove plastic wrapper from media roll. Replace upper end of spool shaft in retainer.
5. Remove threading rod from its storage clips on supply compartment bulkhead.
6. Locate eyelet end of threading wire lying in

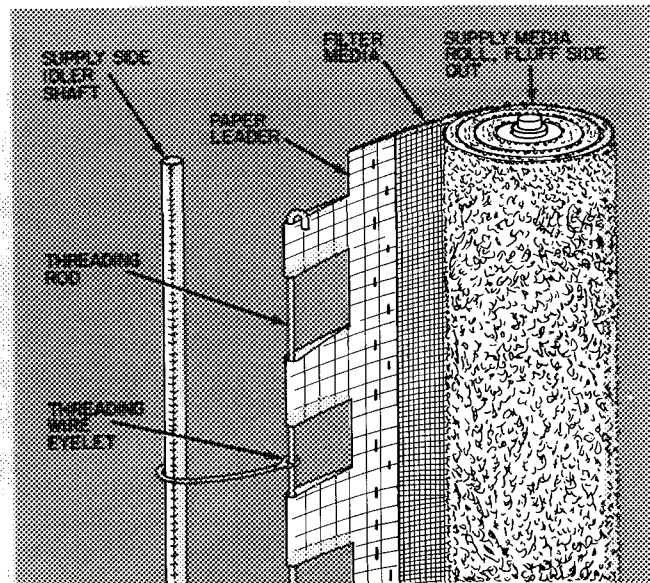

Fig. 7 — Threading Details (Step 6)

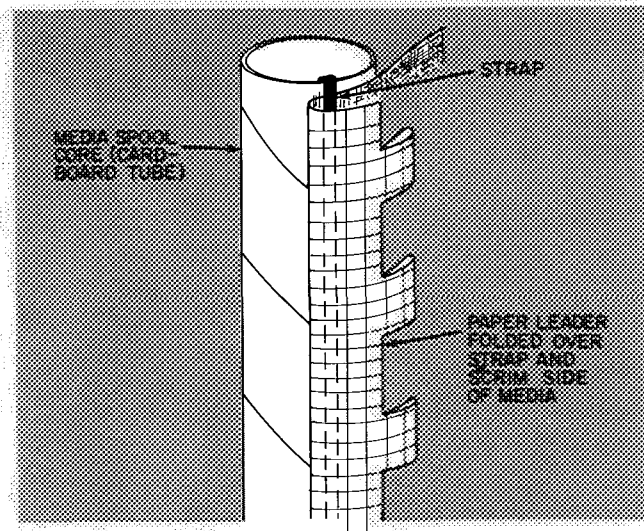

Fig. 8 — Paper Leader Installed on Take-Up Core (Step 9)

7. Pull take-up end of threading wire so that filter media passes around supply side idler shaft and traverses airway from supply side to take-up side. Be sure that threading rod, paper leader and filter media pass thru supply side seals without force. Check that threading operation follows route shown in Fig. 2 so that media emerges thru take-up side seals and around take-up side idler shaft without wrinkling or tearing.
8. Remove threading rod and wire from paper leader. Replace threading rod on its storage clips on supply side. Threading wire may be discarded.
9. Insert leader behind strap on take-up core (cardboard tube) and fold it over itself as shown in Fig. 8.



10. Set power switch at ON so that take-up spool makes 2 complete turns. Be sure that paper leader lies flat against media so that as media winds around core it does not come loose or bunch up. Be sure that media is free of wrinkles and travels without snagging. Again, check that media is routed as shown in Fig. 2.
11. Dual roll sections — Repeat threading procedure for upper media roll. Note that a second threading rod and wire are provided. After upper roll is threaded, about 4 turns of media will be wound on lower take-up spool. Do not operate gear motor any more than necessary. Media cannot be rewound onto supply spool.
12. Set manual override switch at AUTO. as applicable. Then set power switch at ON.
13. Perform operational checks as required. Close and secure access doors. Refer to air handling unit operating instructions as applicable.

### START-UP

**Step 8 — Perform Electrical Control System Checkout** — Control system designed and factory set to provide full-span media advancement when required. Before performing Operational Check, and Complete Electrical Check, described below, review Roll Filter Description (page 8), Wiring Diagrams (Fig. 3 and 4) and Component Description. Be sure that media is correctly installed and routed as shown in Fig. 2.

**CAUTION:** Operation of motor should be limited to that necessary for electrical checks as media which has been advanced cannot be rewound on supply media spool. Read checkout procedures before performing checkouts.

#### OPERATIONAL CHECK (all power is off)

1. Automatic Units — set manual override switch at AUTO.
2. Set media switch at OFF.
3. Turn on power to unit at fused disconnect switch.
4. Set power switch at ON. Read steps 5, 6 and 7; perform in relatively rapid succession.
5. Set media switch at ON.  
Manual Units — Motor should operate.  
Automatic Units — Amber operating light should light up.
6. Automatic Units — Set manual override switch momentarily at MANUAL. Motor should operate momentarily.
7. Swing media runout switch arm away from supply media spool. Depress media runout switch (micro-switch behind runout arm).

Manual Units — Motor should stop.

Automatic Units — Media runout light (red) should light up.

8. Release media runout switch. Restore control circuit to operating status (i.e. media switch at ON, runout switch at AUTO., power switch at ON).

**COMPLETE ELECTRICAL CHECKOUT** to be performed by a qualified electrician only.

Because it has fewer controls, the complete electrical checkout of a manual roll filter section is the same as the operational check described above. The following procedure applies to automatic roll filter section only.

1. Set power switch at OFF. Turn power off at external fused disconnect switch.
2. Remove access panel below control panel (Fig. 2).
3. Restore power at fused external disconnect switch; set power switch at ON.

**CAUTION:** Terminals in main control box are now energized.

4. Perform Operational Check described previously as required.
5. Connect a 36-in. (approximate) piece of 3/8-in. tubing to high-pressure tap on control panel face (Fig. 2).
6. Blow on tube to close pressure switch to simulate high pressure caused by dirty filters. Media advance motor should operate. Refer to Pressure Switch Adjustment described later as required.
7. Maintain pressure on pressure switch long enough to perform step 8.
8. As media advances, allow media metering wheel to revolve thru one revolution. This closes pulse generator switch and energizes sequence relay (Fig. 5 and 6). Review Pulse Generator Assembly description as required.
9. Set power switch at OFF. Shut off power at fused disconnect.
10. Remove tubing from high-pressure tap.
11. Reset sequence relay by manually turning cam clockwise until relay switch arm drops into valley of cam (either cam on sizes 75 and 90).
12. Replace control box cover, restore power at fused disconnect switch and set all switches as follows:  
Media Switch — ON  
Manual Override Switch — AUTO.  
Power Switch — ON
13. Roll filter section is again ready for automatic operation. Check that all is in order. Close and secure access doors before leaving job site.

## SERVICE

**Replacing Dirty Filter Media** — Rethreading clean media roll is not necessary. When clean media is to be installed, simply attach leader of clean media roll to trailer of depleted (dirty) media roll as follows:

1. Shut off system air fan. Open both side access doors (Fig. 2). Automatic units — set manual override switch at MANUAL.
2. Check that supply media roll has been depleted. Swing media runout arm away from supply spool and set media switch at ON so that motor will advance remaining media. When paper trailer is exposed, release runout arm (stopping motor). Then set media switch at OFF.  
NOTE: If a complete increment of clean media can be exposed to airway before paper trailer on supply spool is exposed, adjust media runout switch as described later so that clean media will not be wasted.
3. Disengage paper trailer from supply core (cardboard tube). *Do not operate motor at this time.*
4. Lift supply spool upper shaft retainer, swing out upper end of shaft. Remove the now empty core from supply spool. Do not damage or discard core.
5. Unpack replacement supply media roll, install it on supply spool. Replace upper end of spool in retainer. Note correct position of roll so that as media unrolls fluff side of media will be facing into airstream (Fig. 2).
6. Connect paper leader of replacement media roll to paper trailer of depleted media roll by using threading rod (Fig. 9).
7. Dual-roll sections only — Jog media switch to expose paper trailer of upper (slave) media roll. As this is done, be sure that threading rod in

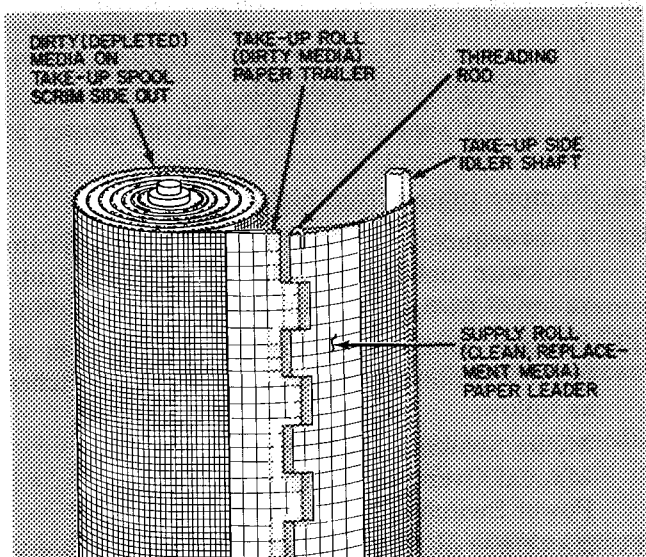

**Fig. 9 — Replacement Media Roll Spliced to Depleted Media Roll**

splice in lower media rolls passes smoothly around supply-side idler shaft and then thru supply-side seals without snagging or wrinkling. Repeat steps 2 thru 6 to replace upper media roll.

8. Set media switch at ON to draw splice(s) across airway opening. Check that threading rod(s), splice(s) and media travel smoothly. When (lower) threading rod and splice reach take-up side set media switch at OFF.
9. Remove threading rod to disconnect paper trailer of depleted roll from paper leader of replacement roll. Replace threading rod on its storage clips in supply side.
10. Lift take-up spool shaft retainer; swing out upper end of take-up spool. Remove depleted media roll from take-up spool. Pack dirty media roll in now-empty replacement roll carton. Dispose of dirty media roll as suitable.
11. Install empty core (cardboard tube removed in step 4) on take-up spool. Replace upper end of take-up spool shaft in shaft retainer.
12. Insert leader behind strap on take-up core (Fig. 8). Fold leader over itself. Note rotation of take-up spool (Fig. 2).
13. Set power switch at OFF.
14. Set media switch at ON.
15. Jog power switch so that about 2 turns of clean media roll winds up on take-up spool to secure paper leader end of roll on to core. On dual-roll sections this will also advance upper media roll so that splice will pass thru upper take-up-side seals, pass around take-up idler shaft and reach upper take-up spool.
16. Dual roll sections — Disconnect splice in upper depleted and replacement rolls; connect upper replacement media roll to upper take-up spool (i.e. repeat steps 9 thru 15). Be sure that media travels smoothly and that paper leader is evenly secured. Replace threading rod in its storage clips on supply side.
17. Manual Units — Leave media switch at ON. Set power switch at OFF.  
Automatic Units — Set manual override switch at AUTO. Set media switch at ON, then set power switch at ON.
18. To check that all is in order, perform Operational Checks as required. Close and secure access doors before leaving job site.

**Media Runout Switch** (Fig. 2) — Switch is factory set to prevent media advancement when supply spool media is depleted. Incorrect setting may cause excessive media to remain on supply spool or cause media to be pulled off supply spool core before shutting off advance cycle.

Runout switch is activated by adjustable bolt on runout arm when arm is 3/8-in. away from spool core. To adjust cutout setting:

1. Loosen adjusting screw locknut.
2. Turn adjustable bolt so that runout switch opens when runout arm comes within 3/8-in. of core.
3. Tighten adjusting screw locknut. Recheck setting.

**Pressure Switch** (Fig. 2) — As filter media becomes dirty, high-pressure drop thru media reduces airflow. Pressure switch is factory set at 0.55 in. wg. Field adjustment should not be necessary. When pressure sensed by high-pressure fitting on control panel face reaches this setting, pressure switch shuts off amber operating light and energizes pulse generator sequence relay and motor. As clean media advances across airway, pressure drop across media decreases and switch returns to illuminate amber operating light. To check and/or adjust pressure switch setting:

1. Shut off system air fan. Open take-up side access door. Shut off power at fused disconnect. Set power switch at OFF.
2. Disconnect yellow or gray motor lead at terminal board no. 1 (TB1-3 or 4) to prevent motor operation. Tape off lead.
3. Set power switch at ON. Turn on power at fused disconnect.
4. Remove red plastic cap from pressure switch to expose adjusting screw. Do not loosen 1-in. hex locknut. *Nut is locked to provide mechanical stop for minimum differential pressure setting.*
5. Connect a draft gage to high-pressure port on control panel.
6. Apply controlled pressure gradually to high-pressure port until amber operating light goes out. Note draft gage reading. This is switch set point (factory setting 0.55 in. wg).
7. Turn adjusting screw counterclockwise to decrease static pressure setting or clockwise to increase static pressure setting as required. A 1/2 turn changes setting approximately 0.13 in. wg.
8. Remove draft gage. Replace red plastic cap on adjusting screw.
9. Shut off power at fused disconnect. Set power switch at OFF. Reconnect motor lead. Turn on power at fused disconnect. Set power switch at ON.
10. Perform any other operational checks as required. Close and secure access door. Restore air system operation.

**Motor Gear-Drive Assembly** (Fig. 2 and 10) — Assembly advances clean media across filter section airway. It consists of a motor and drive sprocket, a roller chain and a take-up spool sprocket on a support plate. Chain tension is factory set so that deflection of chain at midpoint is 1/4-inch. To adjust chain tension, loosen motor mounting bolts (3), reposition motor on slotted mounting holes in support plate until correct tension is achieved. Tighten motor hold-down bolts.

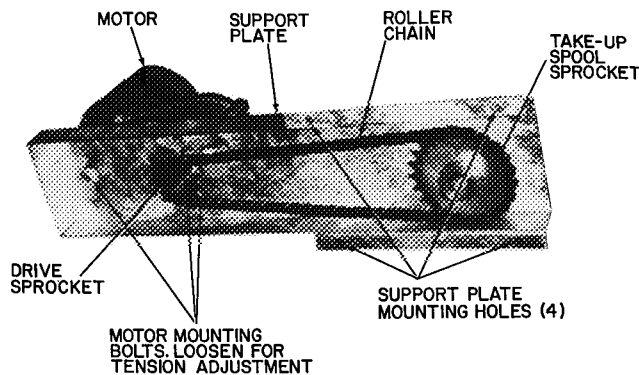

Fig. 10 — Motor Gear-Drive Details

Lubricate chain with a light graphite oil once each year.

**Media Tension Brake** (Fig. 11) — Brake is mounted on bottom panel of supply spool side to provide tension on supply spool at bottom end of spool shaft. Two brake shoes held in place by 2 helical springs cause friction (drag) required for proper media tension. Brake assembly includes supply spool bearing surface and slotted axis shaft. Except for making sure that helical springs and shoes are in tension, no other maintenance is required.

**Shear Pin** — Take-up spool shaft is fastened to keeper on take-up spool disk at base of spool by a bolt and locknut. This bolt acts as a shear pin to prevent damage to motor gear-drive. In the event of mechanical failure which could cause excessive tension on motor gear-drive, bolt will shear allowing motor to operate freely and continuously. Eventually, amber operating light will go out (as described elsewhere) and stay out as indication of malfunction.

**Cleaning and Lubrication** — The only cleaning necessary in addition to general housekeeping is removal of loose fibers around shaft bearings. Shaft bearings and gear motor require no routine maintenance. Refer to specific component description for additional information as required.

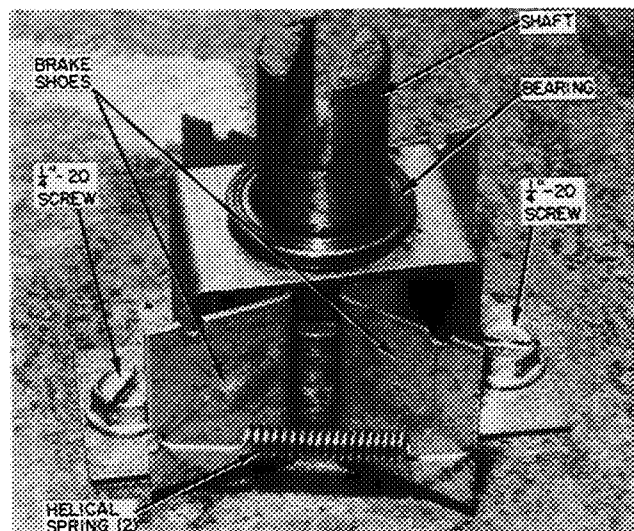

Fig. 11 — Media Tension Brake

**For replacement items use Carrier Specified Parts.**

**Manufacturer reserves the right to discontinue, or change at any time, specifications or designs without notice and without incurring obligations.**

<b>Book</b>	<b>3</b>
<b>Tab</b>	<b>1b</b>

Form 39E-11SI Supersedes 31NA-1SI

Printed in U S A

5-78

PC 201

Catalog No 533-925