



# Installation, Start-Up and Service Instructions

## CONTENTS

	Page
<b>SAFETY CONSIDERATIONS</b> .....	1
<b>INSTALLATION</b> .....	2-31
<b>Step 1 — Provide Unit Support</b> .....	2
• ROOF CURB	
• ALTERNATE UNIT SUPPORT	
<b>Step 2 — Rig and Place Unit</b> .....	2
• POSITIONING	
• ROOF MOUNT	
<b>Step 3 — Field Fabricate Ductwork</b> .....	9
<b>Step 4 — Make Unit Duct Connections</b> .....	9
<b>Step 5 — Install Flue Hood and Wind Baffle</b> .....	9
<b>Step 6 — Trap Condensate Drain</b> .....	9
<b>Step 7 — Orifice Change</b> .....	10
<b>Step 8 — Install Gas Piping</b> .....	11
<b>Step 9 — Make Electrical Connections</b> .....	11
• FIELD POWER SUPPLY	
• FIELD CONTROL WIRING	
• OPTIONAL NON-FUSED DISCONNECT	
• OPTIONAL CONVENIENCE OUTLET	
<b>Step 10 — Make Outdoor-Air Inlet Adjustments</b> ..	14
<b>Step 11 — Install Outdoor-Air Hood</b> .....	14
<b>Step 12 — Install All Accessories</b> .....	15
• MOTORMASTER® I CONTROL INSTALLATION	
• MOTORMASTER V CONTROL INSTALLATION	
<b>Step 13 — Adjust Factory-Installed Options</b> .....	17
• PREMIERLINK™ CONTROL	
• ENTHALPY SWITCH/RECEIVER	
• OUTDOOR ENTHALPY CONTROL	
• DIFFERENTIAL ENTHALPY CONTROL	
• ENTHALPY SENSORS AND CONTROL	
• OPTIONAL ECONOMISERIV AND ECONOMISER2	
• ECONOMISERIV STANDARD SENSORS	
• ECONOMISERIV CONTROL MODES	
<b>Step 14 — Install Humidistat for Optional MoistureMiSer™ Package</b> .....	29
<b>START-UP</b> .....	31-38
<b>SERVICE</b> .....	39-47
<b>TROUBLESHOOTING</b> .....	48-52
<b>INDEX</b> .....	53
<b>START-UP CHECKLIST</b> .....	CL-1

## SAFETY CONSIDERATIONS

Installation and servicing of air-conditioning equipment can be hazardous due to system pressure and electrical components. Only trained and qualified service personnel should install, repair, or service air-conditioning equipment.

Untrained personnel can perform basic maintenance functions of cleaning coils and filters and replacing filters. All other operations should be performed by trained service personnel. When working on air-conditioning equipment, observe

precautions in the literature, tags and labels attached to the unit, and other safety precautions that may apply.

Follow all safety codes. Wear safety glasses and work gloves. Use quenching cloth for unbrazing operations. Have fire extinguishers available for all brazing operations.

### ⚠ WARNING

Before performing service or maintenance operations on unit, turn off main power switch to unit. Electrical shock could cause personal injury.

### ⚠ WARNING

1. Improper installation, adjustment, alteration, service, or maintenance can cause property damage, personal injury, or loss of life. Refer to the User's Information Manual provided with this unit for more details.
2. Do not store or use gasoline or other flammable vapors and liquids in the vicinity of this or any other appliance.

#### What to do if you smell gas:

1. DO NOT try to light any appliance.
2. DO NOT touch any electrical switch, or use any phone in your building.
3. IMMEDIATELY call your gas supplier from a neighbor's phone. Follow the gas supplier's instructions.
4. If you cannot reach your gas supplier, call the fire department.

### ⚠ WARNING

Disconnect gas piping from unit when pressure testing at pressure greater than 0.5 psig. Pressures greater than 0.5 psig will cause gas valve damage resulting in hazardous condition. If gas valve is subjected to pressure greater than 0.5 psig, it *must* be replaced before use. When pressure testing field-supplied gas piping at pressures of 0.5 psig or less, a unit connected to such piping must be isolated by closing the manual gas valve(s).

**IMPORTANT:** Units have high ambient operating limits. If limits are exceeded, the units will automatically lock the compressor out of operation. Manual reset will be required to restart the compressor.

## INSTALLATION

Inspect unit for transportation damage. If damage is found, file claim with transportation agency.

### Step 1 — Provide Unit Support

**ROOF CURB** — Assemble and install accessory roof curb or horizontal adapter roof curb in accordance with instructions shipped with this accessory. See Fig. 1 and 2. Install insulation, cant strips, roofing, and counter flashing as shown. Ductwork can be installed to roof curb or horizontal adapter roof curb before unit is set in place. Curb or adapter roof curb should be level. This is necessary to permit unit drain to function properly. Unit leveling tolerance is  $\pm 1/16$  in. per linear ft in any direction. Refer to Accessory Roof Curb or Horizontal Adapter Roof Curb Installation Instructions for additional information as required. When accessory roof curb or horizontal adapter roof curb is used, unit may be installed on class A, B, or C roof covering material.

**IMPORTANT:** The gasketing of the unit to the roof curb or adapter roof curb is critical for a watertight seal. Install gasket with the roof curb or adapter as shown in Fig. 2. Improperly applied gasket can also result in air leaks and poor unit performance.

**ALTERNATE UNIT SUPPORT** — When the curb or adapter cannot be used, install unit on a noncombustible surface. Support unit with sleepers, using unit curb support area. If sleepers cannot be used, support long sides of unit with a minimum of 3 equally spaced 4-in. x 4-in. pads on each side.

**Step 2 — Rig and Place Unit** — Do not drop unit; keep upright. Use spreader bars over unit to prevent sling or cable damage. Rollers may be used to move unit across a roof. Level by using unit frame as a reference; leveling tolerance is  $\pm 1/16$  in. per linear ft in any direction. See Fig. 3 for additional information. Unit operating weight is shown in Table 1.

Four lifting holes are provided in ends of unit base rails as shown in Fig. 3. Refer to rigging instructions on unit.

**POSITIONING** — Maintain clearance, per Fig. 4 and 5, around and above unit to provide minimum distance from combustible materials, proper airflow, and service access.

Do not install unit in an indoor location. Do not locate unit air inlets near exhaust vents or other sources of contaminated air. For proper unit operation, adequate combustion and ventilation air must be provided in accordance with Section 5.3 (Air for Combustion and Ventilation) of the National Fuel Gas Code, ANSI Z223.1 (American National Standards Institute).

Although unit is weatherproof, guard against water from higher level runoff and overhangs.

Locate mechanical draft system flue assembly at least 4 ft from any opening through which combustion products could enter the building, and at least 4 ft from any adjacent building. When unit is located adjacent to public walkways, flue assembly must be at least 7 ft above grade.

**ROOF MOUNT** — Check building codes for weight distribution requirements. Unit operating weight is shown in Table 1.

*Instructions continued on page 9.*

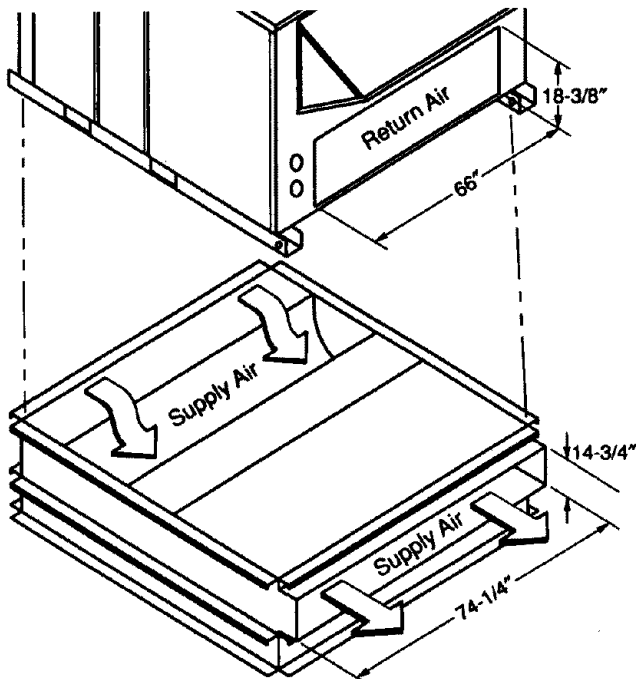

NOTE: CRRFCURB013A00 is a fully factory preassembled horizontal adapter and includes an insulated transition duct. The pressure drop through the adapter curb is negligible.

For horizontal return applications: The power exhaust and barometric relief dampers must be installed in the return air duct.

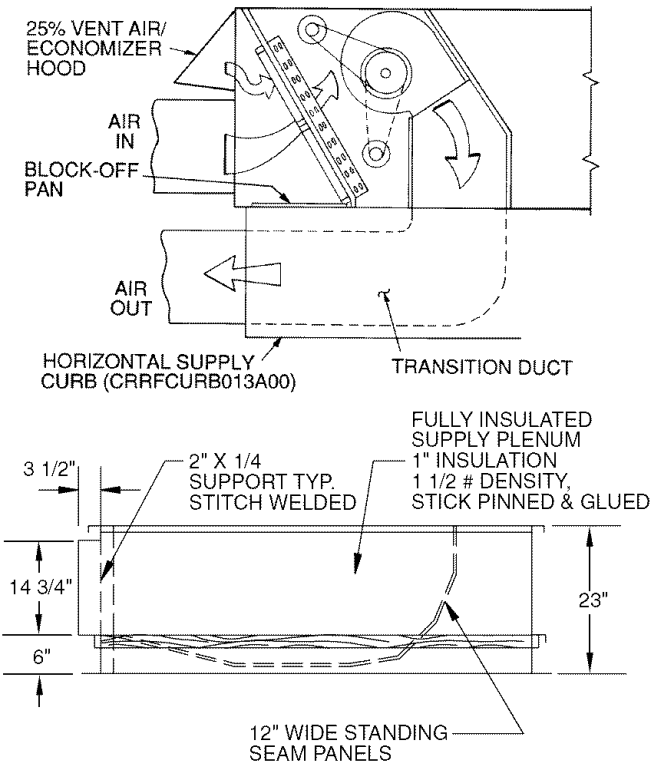

ACCESSORY PACKAGE NO.	CURB HEIGHT	DESCRIPTION
CRRFCURB013A00	1'-11\" (584)	Pre-Assembled, Roof Curb, Horizontal Adapter

**Fig. 1 — Horizontal Supply/Return Adapter Installation**

PKG. NO. REF.	CURB HEIGHT	DESCRIPTION
CRRFCURB010A00	1'- 2" (305)	Standard Curb 14" High
CRRFCURB011A00	2'- 0" (610)	Standard Curb for Units Requiring High Installation
CRRFCURB012A00	2'- 0" (610)	Side Supply and Return Curb for High Installation

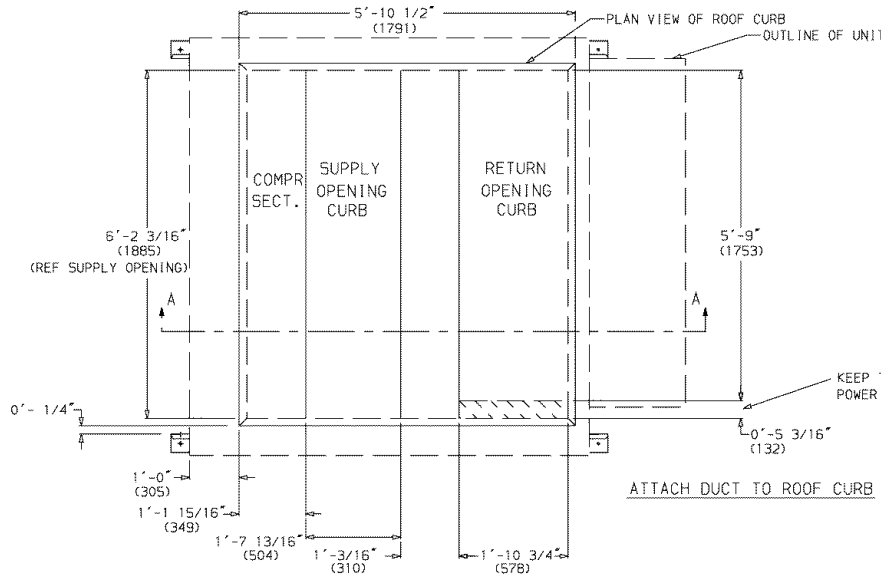

- NOTES:
1. ROOF CURB ACCESSORY IS SHIPPED DISASSEMBLED.
  2. INSULATED PANELS: 1" THICK NEOPRENE COATED 1-1/2 LB DENSITY.
  3. DIMENSIONS IN ( ) ARE IN MILLIMETERS.
  4. → DIRECTION OF AIR FLOW
  5. ROOF CURB: 16 GA. (GA03-56) STL.
  6. A 90 DEGREE ELBOW MUST BE INSTALLED ON THE SUPPLY DUCT WORK BELOW THE UNIT DISCHARGE FOR UNITS EQUIPPED WITH ELECTRIC HEATERS.

NOTE:  
TO PREVENT THE HAZARD OF STAGNANT WATER BUILD-UP IN THE DRAIN PAN OF THE INDOOR SECTION, UNIT CAN ONLY BE PITCHED AS SHOWN.

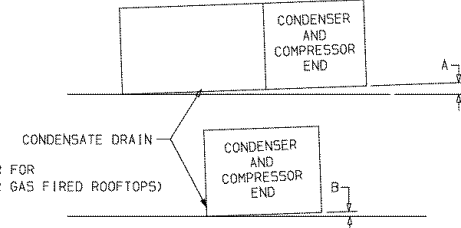

DIMENSIONS (degrees and inches)

UNIT	A		B	
	DEG.	IN.	DEG.	IN.
ALL	.28	.45	.28	.43

UNIT LEVELING TOLERANCES  
\*From edge of unit to horizontal.

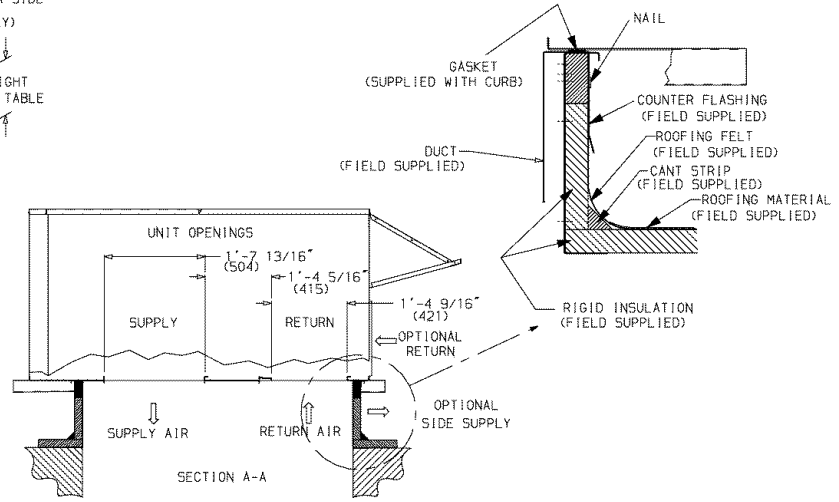
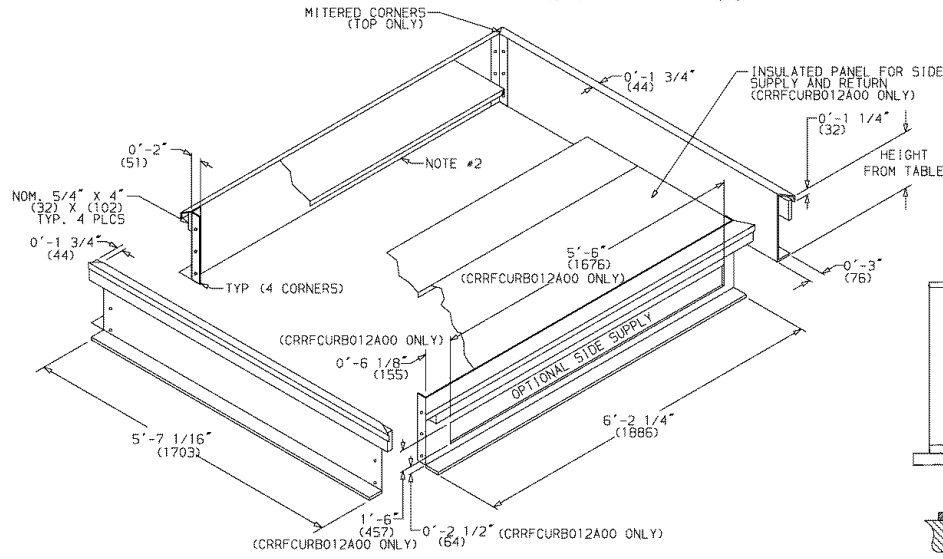
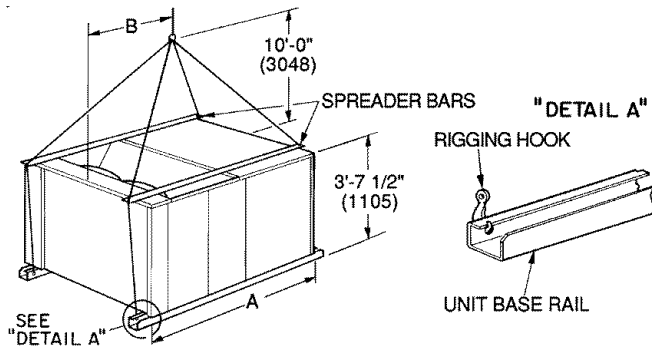

Fig. 2 — Roof Curb Details



**NOTES:**

1. Dimensions in ( ) are in millimeters.
2. Refer to Fig. 4 and 5 for unit operating weights.
3. Remove boards at ends of unit and runners prior to rigging.
4. Rig by inserting hooks into unit base rails as shown. Use corner post from packaging to protect coil from damage. Use bumper boards for spreader bars on all units.
5. Weights do not include optional economizer. Add 90 lb (41 kg) for economizer weight.
6. Weights given are for aluminum evaporator and condenser coil plate fins.

**⚠ CAUTION**  
All panels must be in place when rigging.

UNIT 48TJ	MAXIMUM SHIPPING WEIGHT		DIMENSIONS			
			A		B	
	lb	kg	Ft-in.	mm	Ft-in.	mm
016	1775	805	6-11½	2121	3-5	1041
020	1875	850	6-11½	2121	3-3	991
024	1985	900	6-11½	2121	3-2	965
028	2135	968	6-11½	2121	3-2	965

**Fig. 3 — Rigging Details**

UNIT	STD UNIT WEIGHT		ECONOMIZER WEIGHT		CORNER A		CORNER B		CORNER C		CORNER D		DIM A		DIM B		DIM C	
	lb	kg	lb	kg	lb	kg	lb	kg	lb	kg	lb	kg	ft-in.	mm	ft-in.	mm	ft-in.	mm
48TJD, TJF016	1650	748	90	41	423	192	386	175	403	183	438	199	3-5	1041	3-5	1041	1-10	559
48TJD, TJF020	1800	816	90	41	432	196	410	186	461	209	472	214	3-3	991	3-7	1092	1-8	508

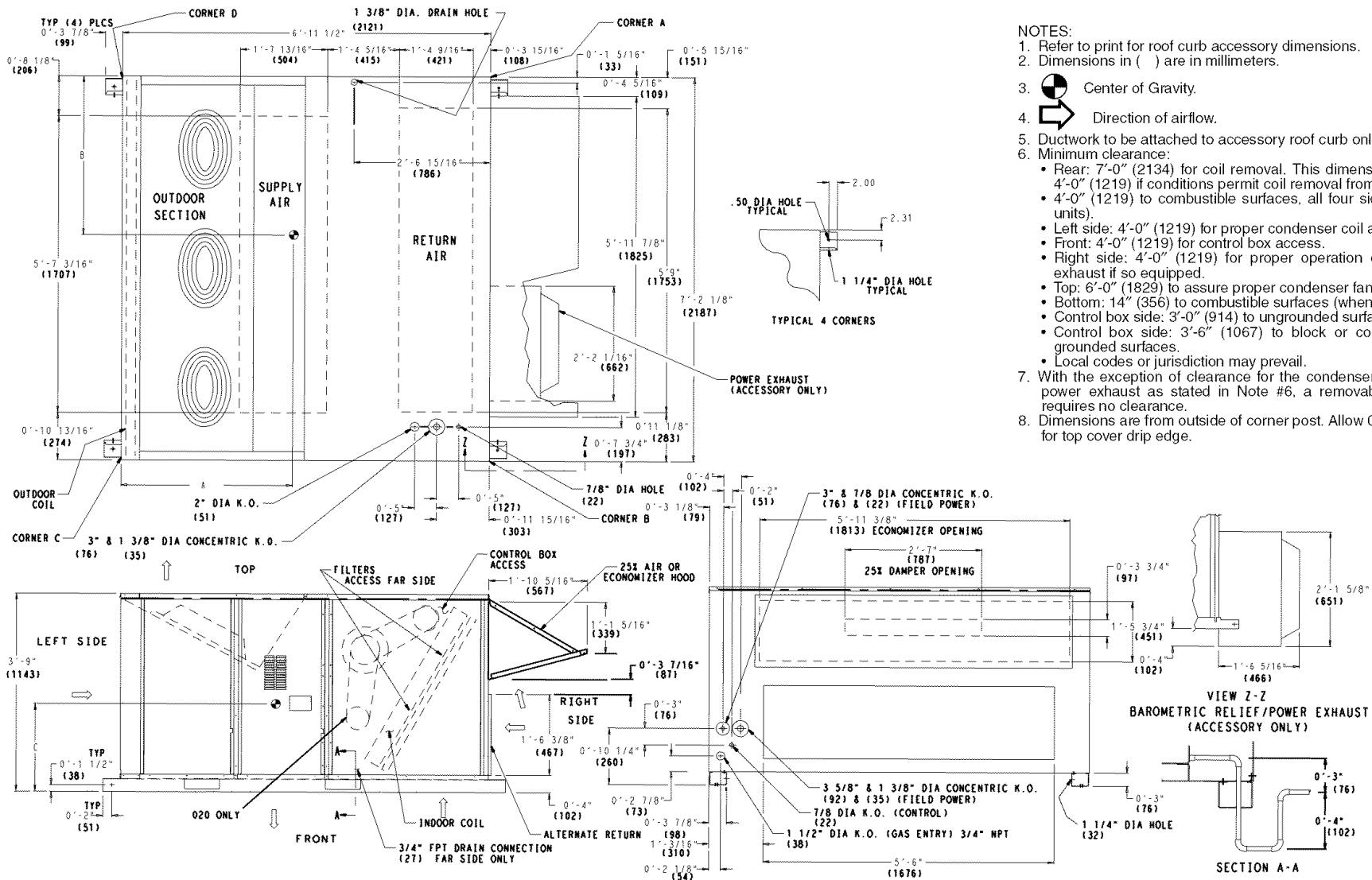

NOTES:

- Refer to print for roof curb accessory dimensions.
- Dimensions in ( ) are in millimeters.
- Center of Gravity.
- Direction of airflow.
- Ductwork to be attached to accessory roof curb only.
- Minimum clearance:
  - Rear: 7'-0" (2134) for coil removal. This dimension can be reduced to 4'-0" (1219) if conditions permit coil removal from the top.
  - 4'-0" (1219) to combustible surfaces, all four sides (includes between units).
  - Left side: 4'-0" (1219) for proper condenser coil airflow.
  - Front: 4'-0" (1219) for control box access.
  - Right side: 4'-0" (1219) for proper operation of damper and power exhaust if so equipped.
  - Top: 6'-0" (1829) to assure proper condenser fan operation.
  - Bottom: 14" (356) to combustible surfaces (when not using curb).
  - Control box side: 3'-0" (914) to ungrounded surfaces, non-combustible.
  - Control box side: 3'-6" (1067) to block or concrete walls, or other grounded surfaces.
- Local codes or jurisdiction may prevail.
- With the exception of clearance for the condenser coil and the damper/power exhaust as stated in Note #6, a removable fence or barricade requires no clearance.
- Dimensions are from outside of corner post. Allow 0'-5/16" (8) on each side for top cover drip edge.

Fig. 4 — Base Unit Dimensions; 48TJ016,020

UNIT	STD UNIT WEIGHT		ECONOMIZER WEIGHT		CORNER A		CORNER B		CORNER C		CORNER D		DIM A		DIM B		DIM C	
	lb	kg	lb	kg	lb	kg	lb	kg	lb	kg	lb	kg	ft-in.	mm	ft-in.	mm	ft-in.	mm
48TJD, TJF024	1850	839	90	41	443	201	406	184	476	216	525	238	3-2	965	3-5	1041	1-8	508
48TJD, TJF028	2000	907	90	41	471	214	428	194	526	239	574	260	3-2	965	3-5	1041	1-8	508

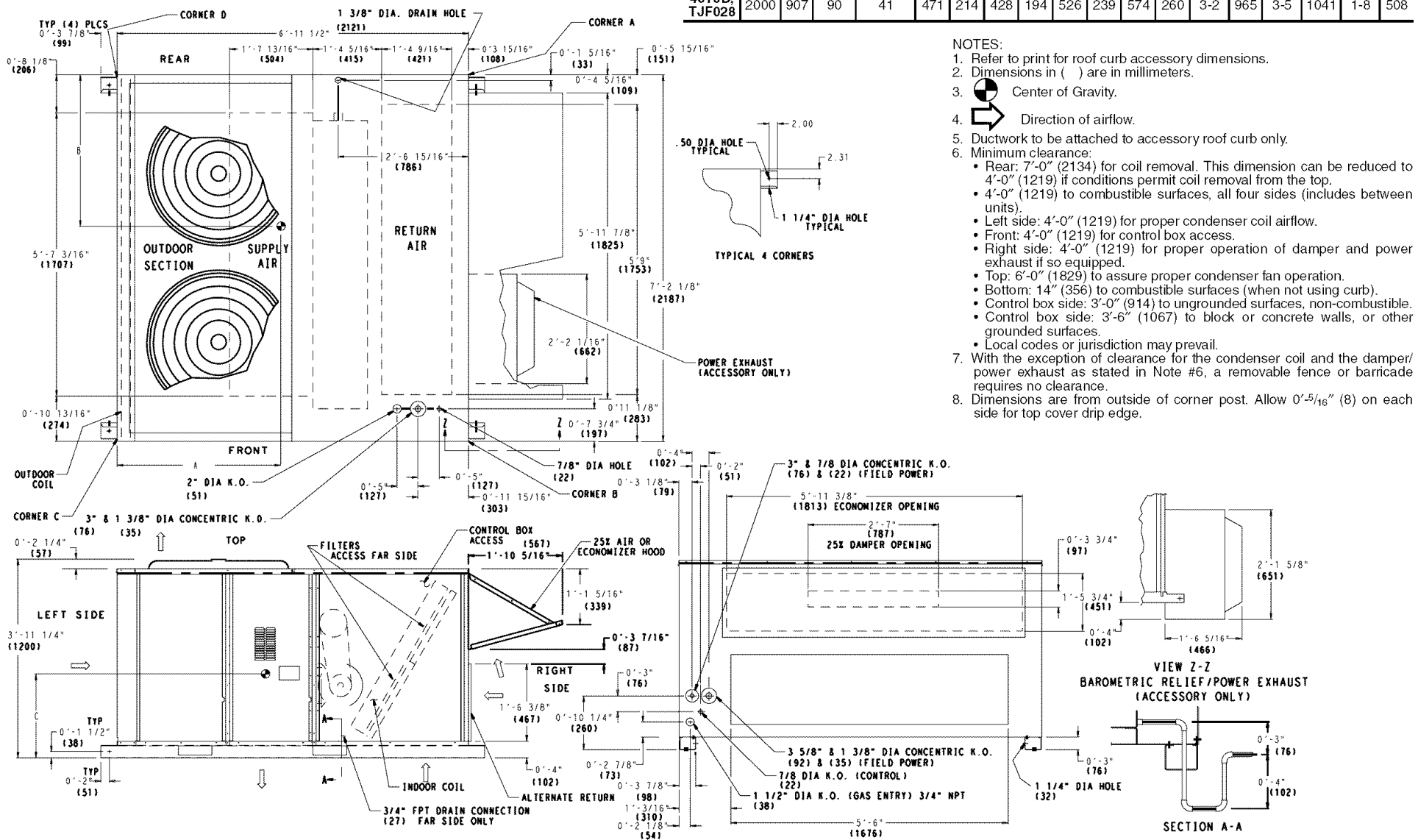

Fig. 5 — Base Unit Dimensions; 48TJ024,028

**Table 1 — Physical Data**

UNIT 48TJ	016D/F		020D/F	024D/F	028D/F
	208/230, 460 v	575 v			
<b>NOMINAL CAPACITY (tons)</b>	15		18	20	25
<b>OPERATING WEIGHT (lb)</b>	1650		1800	1850	2000
Economizer	90		90	90	90
Roof Curb	200		200	200	200
<b>COMPRESSOR</b>	Scroll				
Quantity...Model (Ckt 1, Ckt 2)	2...SR*942AE		1...SM120, 1...SR*782AE	1...SM120, 1...SM110	1...SM161, 1...SM120
Number of Refrigerant Circuits	2		2	2	2
Oil (oz) (Ckt 1, Ckt 2)	90, 90		110, 72	110, 110	112, 110
Stages of Capacity Control (%)	50/50		60/40	52/48	56/44
<b>REFRIGERANT TYPE</b>	R-22				
Expansion Device	TXV				
Operating Charge (lb-oz)	10-13		15-2	16-3	21-0
Circuit 1*	10-5		11-5	14-8	15-4
Circuit 2					
<b>CONDENSER COIL</b>	Cross-Hatched 3/8-in. Copper Tubes, Aluminum Lanced, Aluminum Pre-Coated, or Copper Plate Fins				
Rows...Fins/in.	2...17		3...15	3...15	4...15
Total Face Area (sq ft)	21.7		21.7	21.7	21.7
<b>CONDENSER FAN</b>	Propeller Type				
Nominal Cfm	10,400		9300	13,700	12,500
Quantity...Diameter (in.)	3...22		3...22	2...30	2...30
Motor Hp...Rpm	1/2...1050		1/2...1050	1...1075	1...1075
Watts Input (Total)	1100		1100	3400	3400
<b>EVAPORATOR COIL</b>	Cross-Hatched 3/8-in. Copper Tubes, Aluminum Lanced or Copper Plate Fins, Face Split				
Rows...Fins/in.	2...17		3...15	3...15	4...15
Total Face Area (sq ft)	17.5		17.5	17.5	17.5
<b>EVAPORATOR FAN</b>	Centrifugal Type				
Quantity...Size (in.)	2...10 x 10	2...10 x 10	2...12 x 12	2...12 x 12	2...12 x 12
Type Drive	Belt	Belt	Belt	Belt	Belt
Nominal Cfm	6000	6000	7200	8000	10,000
Motor Hp	3.7	3.0	5	7.5	10
Motor Nominal Rpm	1725	1725	1745	1745	1740
Maximum Continuous Bhp	4.25	3.45	5.90	8.7 [208/230, 575 v]	10.2 [208/230, 575 v]
Motor Frame Size	56H	56H	184T	213T	215T
Nominal Rpm High/Low	—	—	—	—	—
Fan r/s Range	Low-Medium Static 891-1179 High Static 1227-1550	1159-1429	910-1095 1069-1287	1002-1225 1193-1458	1066-1283 1332-1550
Motor Bearing Type	Ball	Ball	Ball	Ball	Ball
Maximum Allowable Rpm	1550	1550	1550	1550	1550
Motor Pulley Pitch Diameter	Low-Medium Static 3.1/4.1 High Static 3.7/4.7	4.3/5.3	4.9/5.9	5.4/6.6	4.9/5.9
Min/Max (in.)	7/8	7/8	1 1/8	1 3/8	1 3/8
Nominal Motor Shaft Diameter (in.)	6.0	6.4	9.4	9.4	8.0
Fan Pulley Pitch Diameter (in.)	Low-Medium Static 5.2 High Static 1 3/16	1 3/16	8.0	7.9	6.4
Nominal Fan Shaft Diameter (in.)	1 3/16	1 3/16	1 7/16	1 7/16	1 7/16
Belt, Quantity...Type...Length (in.)	Low-Medium Static 1...BX...42 High Static 1...BX...42	1...BX...45	1...BX...50 1...BX...48	1...BX...54 1...BX...50	2...BX...50 2...BX...47
Pulley Center Line Distance (in.)	13.5-15.5	13.5-15.5	13.3-14.8	14.6-15.4	14.6-15.4
Speed Change per Full Turn of Movable Pulley Flange (rpm)	Low-Medium Static 48 High Static 55	44	37	37	36
Movable Pulley Maximum Full Turns From Closed Position	5	5	5	5	5
Factory Speed	3.5	3.5	3.5	3.5	3.5
Factory Speed Setting (rpm)	Low-Medium Static 1035 High Static 1389	1296	1002	1120	1182
Fan Shaft Diameter at Pulley (in.)	1 3/16	1 3/16	1 7/16	1 7/16	1 7/16

**LEGEND**

**Bhp** — Brake Horsepower  
**TXV** — Thermostatic Expansion Valve

\*Circuit 1 uses the lower portion of condenser coil and lower portion of evaporator coils; and Circuit 2 uses the upper portion of both coils.  
 †Rollout switch is manual reset.

\*\*The 48TJ028 units requires 2-in. industrial-grade filters capable of handling face velocities of up to 625 ft/min (such as American Air Filter no. 5700 or equivalent).

NOTE: The 48TJ016-028 units have a low-pressure switch (standard) located on the suction side.

**Table 1 — Physical Data (cont)**

UNIT 48TJ	016D/F	020D/F	024D/F	028D/F
<b>FURNACE SECTION</b>				
Rollout Switch Cutout Temp (F)†	190	190	190	190
Burner Orifice Diameter (in. ...drill size) Natural Gas	0.1285...30/0.136...29	0.1285...30/0.136...29	0.1285...30/0.136...29	0.1285...30/0.136...29
Thermostat Heat Anticipator Setting (amps) 208/230, 575				
Stage 1	0.98	0.98	0.98	0.98
Stage 2	0.44	0.44	0.44	0.44
460 v				
Stage 1	0.80	0.80	0.80	0.80
Stage 2	0.44	0.44	0.44	0.44
Gas Input				
Stage 1	172,000/225,000	206,000/270,000	206,000/270,000	206,000/270,000
Stage 2	230,000/300,000	275,000/360,000	275,000/360,000	275,000/360,000
Efficiency (Steady State) (%)	81	81	81	81
Temperature Rise Range	15-45/20-50	15-45/20-50	15-45/20-50	15-45/20-50
Manifold Pressure (in. wg) Natural Gas	3.3	3.3	3.3	3.3
Gas Valve Quantity	1	1	1	1
Field Gas Connection Size (in.-FPT)	3/4	3/4	3/4	3/4
<b>HIGH-PRESSURE SWITCH (psig)</b>				
Cutout			426	
Reset (Auto)			320	
<b>LOW-PRESSURE SWITCH (psig)</b>				
Cutout			27	
Reset (Auto)			44	
<b>FREEZE PROTECTION THERMOSTAT (F)</b>				
Opens			30 ± 5	
Closes			45 ± 5	
<b>OUTDOOR-AIR INLET SCREENS</b>				
Quantity...Size (in.)			Cleanable 2...20 x 25 x 1 1...20 x 20 x 1	
<b>RETURN-AIR FILTERS</b>				
Quantity...Size (in.)			Throwaway** 4...20 x 20 x 2 4...16 x 20 x 2	
<b>POWER EXHAUST</b>				
	1/2 Hp, 208/230-460 v Motor Direct Drive, Propeller-Fan (Factory-Wired for 460 v)			

**LEGEND**

**Bhp** — Brake Horsepower  
**TXV** — Thermostatic Expansion Valve

\*Circuit 1 uses the lower portion of condenser coil and lower portion of evaporator coils; and Circuit 2 uses the upper portion of both coils.  
 †Rollout switch is manual reset.

\*\*The 48TJ028 units requires 2-in. industrial-grade filters capable of handling face velocities of up to 625 ft/min (such as American Air Filter no. 5700 or equivalent).

NOTE: The 48TJ016-028 units have a low-pressure switch (standard) located on the suction side.



**Step 3 — Field Fabricate Ductwork** — Secure all ducts to building structure. Use flexible duct connectors between unit and ducts as required. Insulate and weatherproof all external ductwork, joints, and roof openings with counter flashing and mastic in accordance with applicable codes.

Ducts passing through an unconditioned space must be insulated and covered with a vapor barrier.

**Step 4 — Make Unit Duct Connections** — Unit is shipped for thru-the-bottom duct connections. Ductwork openings are shown in Fig. 1, 4, and 5. Duct connections are shown in Fig. 6. Field-fabricated concentric ductwork may be connected as shown in Fig. 7 and 8. Attach all ductwork to roof curb and roof curb basepans.

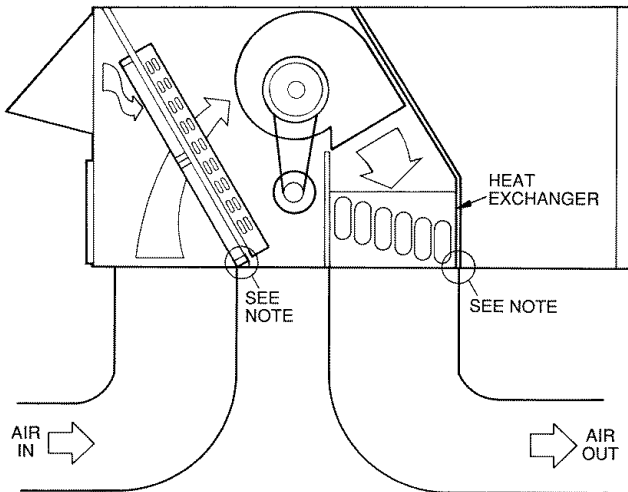

NOTE: Do not drill in this area; damage to basepan may result in water leak.

**Fig. 6 — Air Distribution — Thru-the-Bottom**

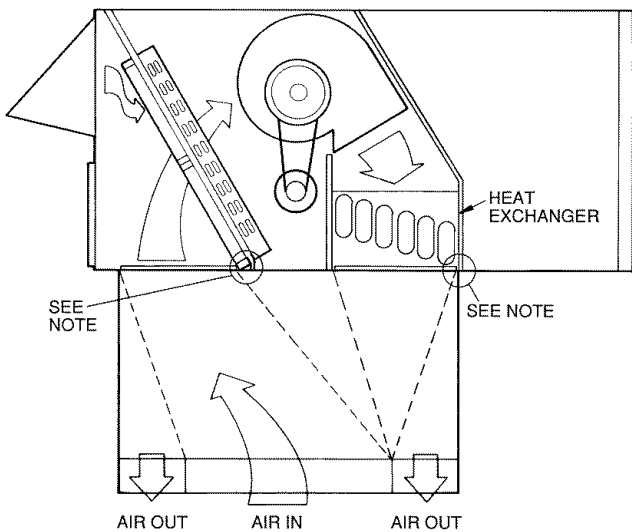

NOTE: Do not drill in this area; damage to basepan may result in water leak.

**Fig. 7 — Concentric Duct Air Distribution**

**Step 5 — Install Flue Hood and Wind Baffle** — Flue hood and wind baffle are shipped secured under main control box. To install, secure flue hood to access panel. See Fig. 9. The wind baffle is then installed over the flue hood.

NOTE: When properly installed, flue hood will line up with combustion fan housing. See Fig. 10.

**Step 6 — Trap Condensate Drain** — See Fig. 11 for drain location. One 3/4-in. half coupling is provided inside unit evaporator section for condensate drain connection. An 8 1/2-in. x 3/4-in. diameter and 2-in. x 3/4-in. diameter pipe nipple, coupled to standard 3/4-in. diameter elbows, provide a straight path down through hole in unit base rails (see Fig. 12). A trap at least 4-in. deep must be used.

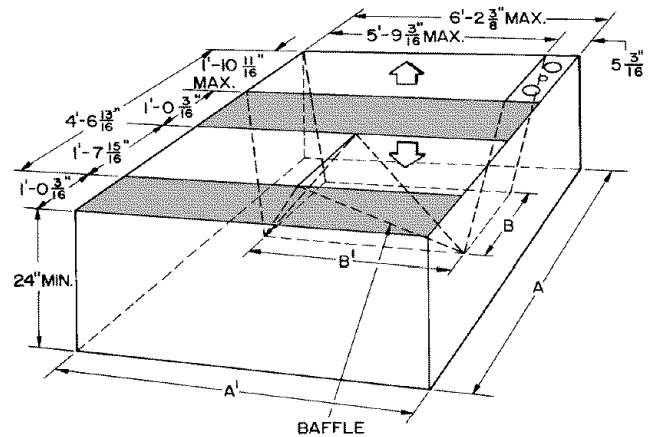

NOTE: Dimensions A, A', and B' are obtained from field-supplied ceiling diffuser.

Shaded area indicates block-off panels.

**Fig. 8 — Concentric Duct Details**

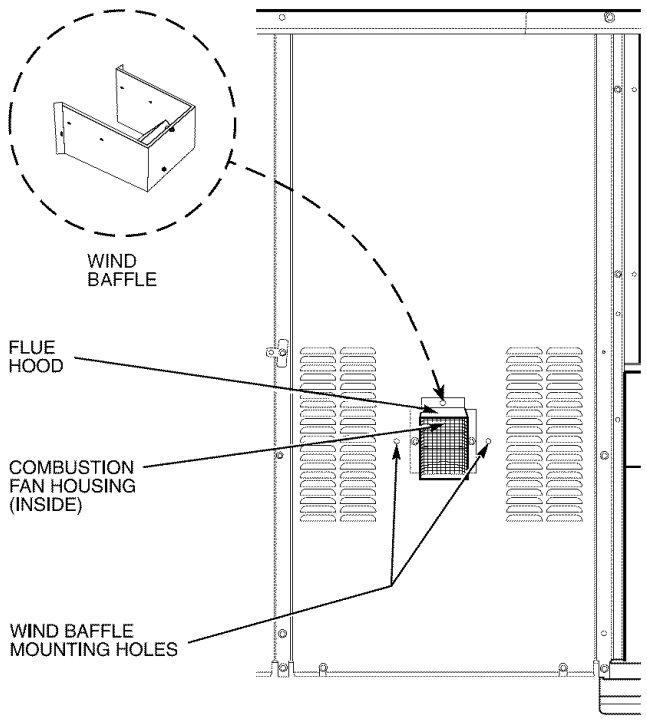

**Fig. 9 — Flue Hood Location**

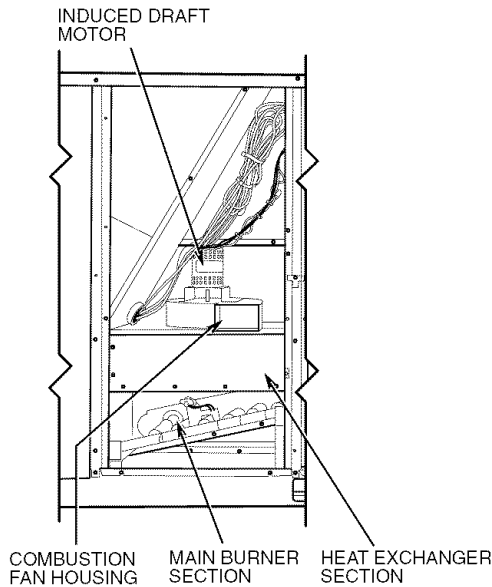

**Fig. 10 — Combustion Fan Housing Location**

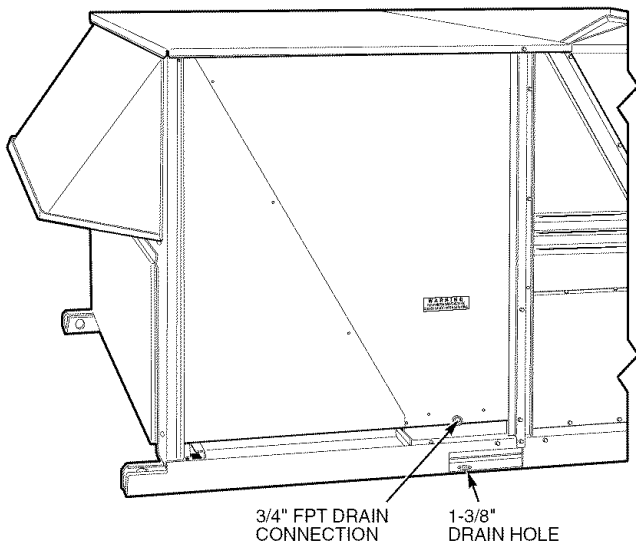

**Fig. 11 — Condensate Drain Details (48TJ016 Shown)**

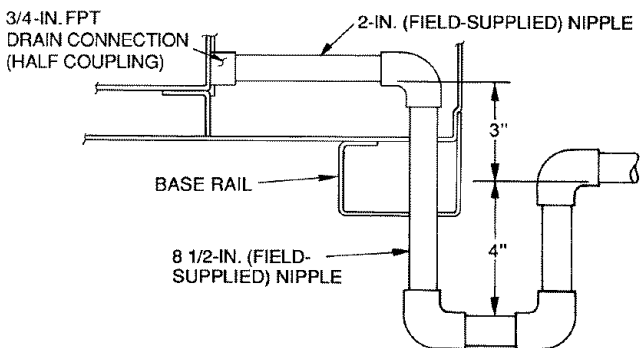

**Fig. 12 — Condensate Drain Piping Details**

**Step 7 — Orifice Change** — This unit is factory assembled for heating operation using natural gas at an elevation from sea level to 2000 ft. This unit uses orifice type LH32RFnnn, where “nnn” indicates the orifice size based on drill size diameter in thousands of an inch.

**HIGH ELEVATION (Above 2000 ft)** — Use accessory high altitude kit when installing this unit at an elevation of 2000 to 7000 ft. For elevations above 7000 ft, refer to Table 2 to identify the correct orifice size for the elevation. See Table 3 for the number of orifices required for each unit size. Purchase these orifices from your local Carrier dealer. Follow instructions in accessory Installation Instructions to install the correct orifices.

**Table 2 — Altitude Compensation\***

ELEVATION (ft)	NATURAL GAS ORIFICE†	
	Low Heat	High Heat
0-1,999	30	29
2,000	30	29
3,000	31	30
4,000	31	30
5,000	31	30
6,000	31	30
7,000	32	31
8,000	32	31
9,000	33	31
10,000	35	32

\*As the height above sea level increases, there is less oxygen per cubic foot of air. Therefore, heat input rate should be reduced at higher altitudes. Includes a 4% input reduction per each 1000 ft.  
†Orifices available through your Carrier dealer.

**Table 3 — Orifice Quantity**

UNIT	ORIFICE QUANTITY
48TJD016	5
48TJD020, 48TJD024, 48TJD028, 48TJF016	6
48TJF020, 48TJF024, 48TJF028	7

**CONVERSION TO LP (Liquid Propane) GAS** — Use accessory LP gas conversion kit when converting this unit for use with LP fuel usage for elevations up to 7000 ft. For elevations above 7000 ft, refer to Table 4 to identify the correct orifice size for the elevation. See Table 3 for the number of orifices required for each unit size. Purchase these orifices from your local Carrier dealer. Follow instructions in accessory Installation Instructions to install the correct orifices.

**Table 4 — LP Gas Conversion\***

ELEVATION (ft)	LP GAS ORIFICE†
0-1,999	36
2,000	37
3,000	38
4,000	38
5,000	39
6,000	40
7,000	41
8,000	41
9,000	42
10,000	43

\*As the height above sea level increases, there is less oxygen per cubic foot of air. Therefore, heat input rate should be reduced at higher altitudes. Includes a 4% input reduction per each 1000 ft.  
†Orifices available through your Carrier dealer.

**Step 8 — Install Gas Piping** — Unit is equipped for use with natural gas. Installation must conform with local building codes or, in the absence of local codes, with the National Fuel Gas Code, ANSI Z223.1.

Install field-supplied manual gas shutoff valve with a 1/8-in. NPT pressure tap for test gage connection at unit. Field gas piping must include sediment trap and union. See Fig. 13.

**⚠ WARNING**  
Do not pressure test gas supply while connected to unit. Always disconnect union before servicing. Exceeding maximum manifold pressure may cause explosion and injury.

**IMPORTANT:** Natural gas pressure at unit gas connection must not be less than 5.5 in. wg or greater than 13.5 in. wg.

Size gas-supply piping for 0.5-in. wg maximum pressure drop. Do not use supply pipe smaller than unit gas connection.

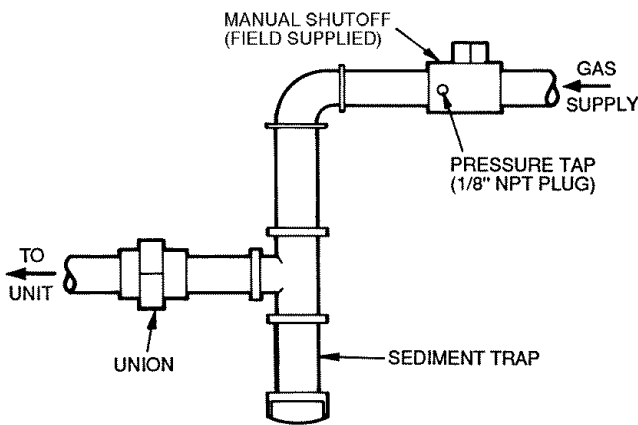

Fig. 13 — Field Gas Piping

**Step 9 — Make Electrical Connections**

**FIELD POWER SUPPLY** — Unit is factory wired for voltage shown on nameplate.

When installing units, provide a disconnect per NEC (National Electrical Code) of adequate size (Table 5).

All field wiring must comply with NEC and local requirements.

Route power ground lines through control box end panel or unit basepan (see Fig. 4 and 5) to connections as shown on unit wiring diagram and Fig. 14.

**⚠ CAUTION**  
The correct power phasing is critical in the operation of the scroll compressors. An incorrect phasing will cause the compressor to rotate in the wrong direction. This may lead to premature compressor failure.

**⚠ WARNING**  
The unit must be electrically grounded in accordance with local codes and NEC ANSI/NFPA 70 (National Fire Protection Association) to protect against fire and electric shock.

Field wiring must confirm to temperature limitations for type "T" wire. All field wiring must comply with NEC and local requirements.

Transformer no. 1 is wired for 230-v unit. If 208/230-v unit is to be run with 208-v power supply, the transformer must be rewired as follows:

1. Remove cap from red (208 v) wire.
2. Remove cap from orange (230 v) spliced wire.
3. Replace orange wire with red wire.
4. Recap both wires.

**⚠ CAUTION**  
Be certain unused wires are capped. Failure to do so may damage the transformers.

Operating voltage to compressor must be within voltage range indicated on unit nameplate. On 3-phase units, voltages between phases must be balanced within 2%.

Unit failure as a result of operation on improper line voltage or excessive phase imbalance constitutes abuse and may cause damage to electrical components.

**FIELD CONTROL WIRING** — Install a Carrier-approved accessory thermostat assembly according to installation instructions included with accessory. Locate thermostat assembly on a solid interior wall in the conditioned space to sense average temperature.

Route thermostat cable or equivalent single leads of colored wire from subbase terminals through conduit in unit to low-voltage connections as shown on unit label wiring diagram and in Fig. 15.

**NOTE:** For wire runs up to 50 ft, use no. 18 AWG (American Wire Gage) insulated wire (35 C minimum). For 50 to 75 ft, use no. 16 AWG insulated wire (35 C minimum). For over 75 ft, use no. 14 AWG insulated wire (35 C minimum). All wire larger than no. 18 AWG cannot be directly connected at the thermostat and will require a junction box and splice at the thermostat.

Set heat anticipator settings as follows:

VOLTAGE	W1	W2
208/230,575	0.98	0.44
460	0.80	0.44

Settings may be changed slightly to provide a greater degree of comfort for a particular installation.

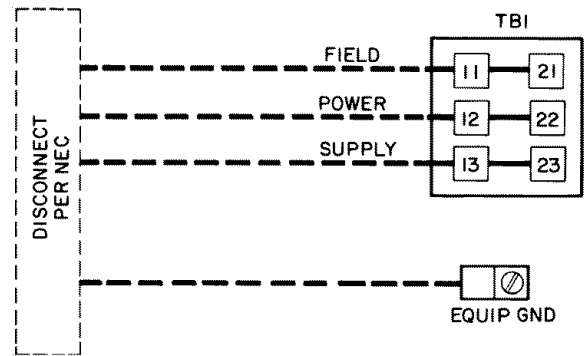

**LEGEND**  
EQUIP — Equipment  
GND — Ground  
NEC — National Electrical Code  
TB — Terminal Block

**NOTE:** The maximum wire size for TB1 is 2/0.

Fig. 14 — Field Power Wiring Connections

**OPTIONAL NON-FUSED DISCONNECT** — On units with the optional non-fused disconnect, incoming power will be wired into the disconnect switch. Refer to Fig. 16 for wiring for 100 and 200 amp disconnect switches. Units with an MOCP under 100 will use the 100 amp disconnect switch. Units with an MOCP over 100 will use the 200 amp disconnect switch. Refer to the applicable disconnect wiring diagram.

To prevent breakage during shipping, the disconnect handle and shaft are shipped and packaged inside the unit control box. Install the disconnect handle before unit operation. To install the handle and shaft, perform the following procedure:

1. Open the control box door and remove the handle and shaft from shipping location.
2. Loosen the Allen bolt located on the disconnect switch. The bolt is located on the square hole and is used to hold the shaft in place. The shaft cannot be inserted until the Allen bolt is moved.
3. Insert the disconnect shaft into the square hole on the disconnect switch. The end of the shaft is specially cut and the shaft can only be inserted in the correct orientation.
4. Tighten the Allen bolt to lock the shaft into position.
5. Close the control box door.
6. Attach the handle to the external access door with the two screws provided. When the handle is in the ON position, the handle will be vertical. When the handle is in the OFF position, the handle will be horizontal.
7. Turn the handle to the OFF position and close the door. The handle should fit over the end of the shaft when the door is closed.
8. The handle must be in the OFF position to open the control box door.

**OPTIONAL CONVENIENCE OUTLET** — On units with optional convenience outlet, a 115-v GFI (ground fault interrupt) convenience outlet receptacle is provided for field wiring. Field wiring should be run through the  $\frac{7}{8}$ -in. knockout provided in the basepan near the return air opening.

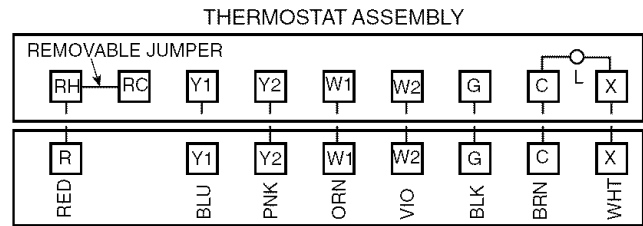

**Fig. 15 — Field Control Thermostat Wiring**

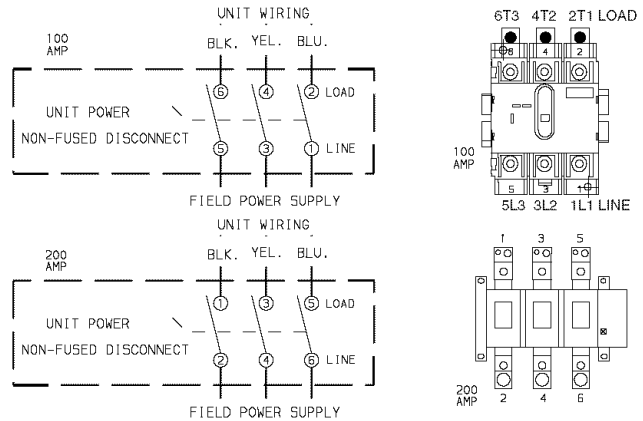

NOTE: The disconnect takes the place of TB-1 as shown on the unit wiring diagram label and the component arrangement label.

**Fig. 16 — Optional Non-Fused Disconnect Wiring**

Table 5 — Electrical Data

UNIT 48TJ	NOMINAL VOLTAGE (3 Ph, 60 Hz)	VOLTAGE RANGE		COMPRESSOR				OFM			IFM		POWER EXHAUST		COMBUSTION FAN MOTOR		POWER SUPPLY	
				No. 1		No. 2		Qty	Hp	FLA (ea)	Hp	FLA	FLA	LRA	FLA	MCA	MOCP*	
		Min	Max	RLA	LRA	RLA	LRA											
016 (15 Tons)	208/230	187	253	25.6	190	25.6	190	3	0.5	1.7	3.7	10.5/11.0	—	—	0.57	74/74	90/90	
													4.6	18.8	0.57	79/79	100/100	
	460	414	508	13.5	95	13.5	95	3	0.5	0.8	3.7	4.8	—	—	0.30	38	50	
													2.3	6.0	0.30	40	50	
	575	518	632	10.2	75	10.2	75	3	0.5	0.8	3.0	3.9	—	—	0.57	30	35	
													2.1	4.8	0.57	32	40	
020 (18 Tons)	208/230	187	253	33	237	23	184	3	0.5	1.7	5.0	15.8/15.8	—	—	0.57	85/85	110/110	
													4.6	18.8	0.57	90/90	110/110	
	460	414	508	16.2	130	10.2	90	3	0.5	0.8	5.0	7.9	—	—	0.30	41	50	
													2.3	6.0	0.30	43	50	
	575	518	632	12.7	85	9	73	3	0.5	0.8	5.0	6.0	—	—	0.57	33	45	
													2.1	4.8	0.57	35	45	
024 (20 Tons)	208/230	187	253	33	237	29.5	237	2	1	6.6	7.5	25.0/25.0	—	—	0.57	109/109	125/125	
													4.6	18.8	0.57	114/114	125/125	
	460	414	508	16.2	130	14.1	130	2	1	3.3	7.5	13.0	—	—	0.30	54	70	
													2.3	6.0	0.30	56	70	
	575	518	632	12.7	85	11.3	85	2	1	3.4	7.5	10.0	—	—	0.57	44	50	
													2.1	4.8	0.57	46	50	
028 (25 Tons)	208/230	187	253	47.5	265	33	237	2	1	6.6	10.0	28.0/28.0	—	—	0.57	134/134	175/175	
													4.6	18.8	0.57	138/138	175/175	
	460	414	508	22.9	145	16.2	130	2	1	3.3	10.0	14.6	—	—	0.30	66	80	
													2.3	6.0	0.30	68	90	
	575	518	632	17.9	102	12.7	85	2	1	3.4	10.0	13.0	—	—	0.57	55	70	
													2.1	4.8	0.57	57	70	

LEGEND

- FLA — Full Load Amps
- HACR — Heating, Air Conditioning and Refrigeration
- IFM — Indoor (Evaporator) Fan Motor
- LRA — Locked Rotor Amps
- MCA — Minimum Circuit Amps
- MOCP — Maximum Overcurrent Protection
- NEC — National Electrical Code
- OFM — Outdoor (Condenser) Fan Motor
- RLA — Rated Load Amps

\*Fuse or HACR circuit breaker.



NOTES:

- In compliance with NEC requirements for multimotor and combination load equipment (refer to NEC Articles 430 and 440), the overcurrent protective device for the unit shall be fuse or HACR breaker. Canadian units may be fuse or circuit breaker.
- Unbalanced 3-Phase Supply Voltage**  
Never operate a motor where a phase imbalance in supply voltage is greater than 2%. Use the following formula to determine the percent of voltage imbalance.

$$\% \text{ Voltage Imbalance} = 100 \times \frac{\text{max voltage deviation from average voltage}}{\text{average voltage}}$$

Example: Supply voltage is 460-3-60.

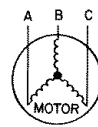

- AB = 452 v
- BC = 464 v
- AC = 455 v

$$\text{Average Voltage} = \frac{452 + 464 + 455}{3}$$

$$= \frac{1371}{3}$$

$$= 457$$

Determine maximum deviation from average voltage.

- (AB) 457 - 452 = 5 v
- (BC) 464 - 457 = 7 v
- (AC) 457 - 455 = 2 v

Maximum deviation is 7 v.

Determine percent of voltage imbalance.

$$\% \text{ Voltage Imbalance} = 100 \times \frac{7}{457}$$

$$= 1.53\%$$

This amount of phase imbalance is satisfactory as it is below the maximum allowable 2%.

**IMPORTANT:** If the supply voltage phase imbalance is more than 2%, contact your local electric utility company immediately.

## Step 10 — Make Outdoor-Air Inlet Adjustments

**MANUAL OUTDOOR-AIR DAMPER** — All units (except those equipped with a factory-installed economizer) have a manual outdoor-air damper to provide ventilation air.

Damper can be preset to admit up to 25% outdoor air into return-air compartment. To adjust, loosen securing screws and move damper to desired setting, then retighten screws to secure damper (see Fig. 17).

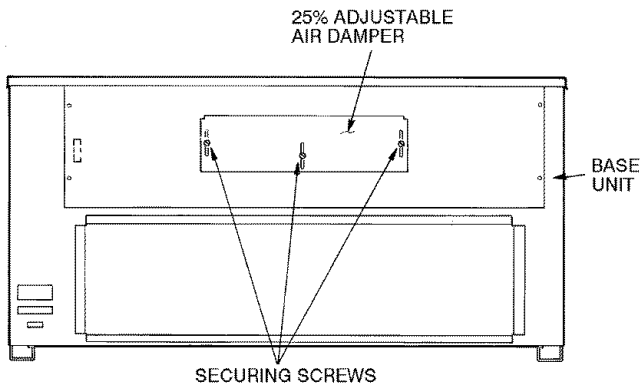

**Fig. 17 — Standard 25% Outdoor-Air Section Details**

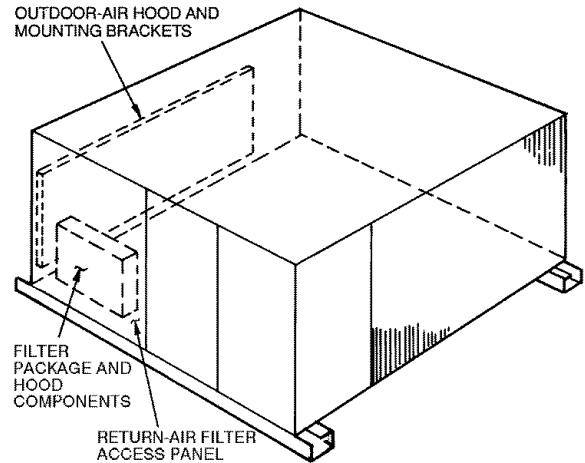

**Fig. 18 — Outdoor-Air Hood Component Location**

## Step 11 — Install Outdoor-Air Hood

**IMPORTANT:** If the unit is equipped with the optional EconoMi\$erIV, move the outdoor air temperature sensor prior to installing the outdoor air hood. See the Optional EconoMi\$erIV and EconoMi\$er2 section for more details.

The outdoor-air hood is common to 25% air ventilation and economizer. If EconoMi\$erIV is used, all electrical connections have been made and adjusted at the factory. Assemble and install hood in the field.

**NOTE:** The hood top panel, upper and lower filter retainers, hood drain pan, baffle (size 024 and 028), and filter support bracket are secured opposite the condenser end of the unit. The screens, hood side panels, remaining section of filter support bracket, seal strip, and hardware are in a package located inside the return-air filter access panel (Fig. 18).

1. Attach seal strip to upper filter retainer. See Fig. 19.
2. Assemble hood top panel, side panels, upper filter retainer, and drain pan (see Fig. 20).
3. Secure lower filter retainer and support bracket to unit. See Fig. 20. Leave screws loose on size 024 and 028 units.
4. Slide baffle (size 024 and 028) behind lower filter retainer and tighten screws.
5. Loosen sheet metal screws for top panel of base unit located above outdoor-air inlet opening, and remove screws for hood side panels located on the sides of the outdoor-air inlet opening.
6. Match notches in hood top panel to unit top panel screws. Insert hood flange between top panel flange and unit. Tighten screws.
7. Hold hood side panel flanges flat against unit, and install screws removed in Step 5.
8. Insert outdoor-air inlet screens and spacer in channel created by lower filter retainer and filter support bracket.

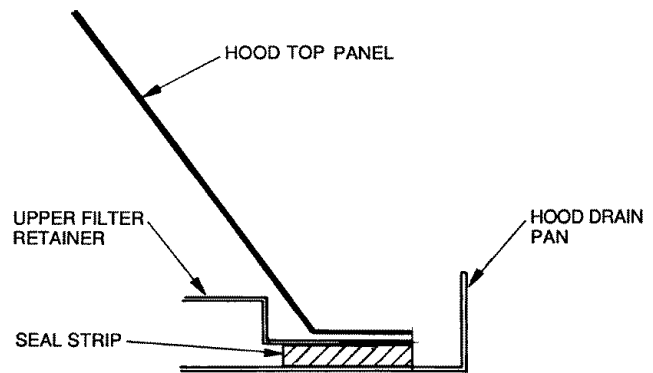

**Fig. 19 — Seal Strip Location**

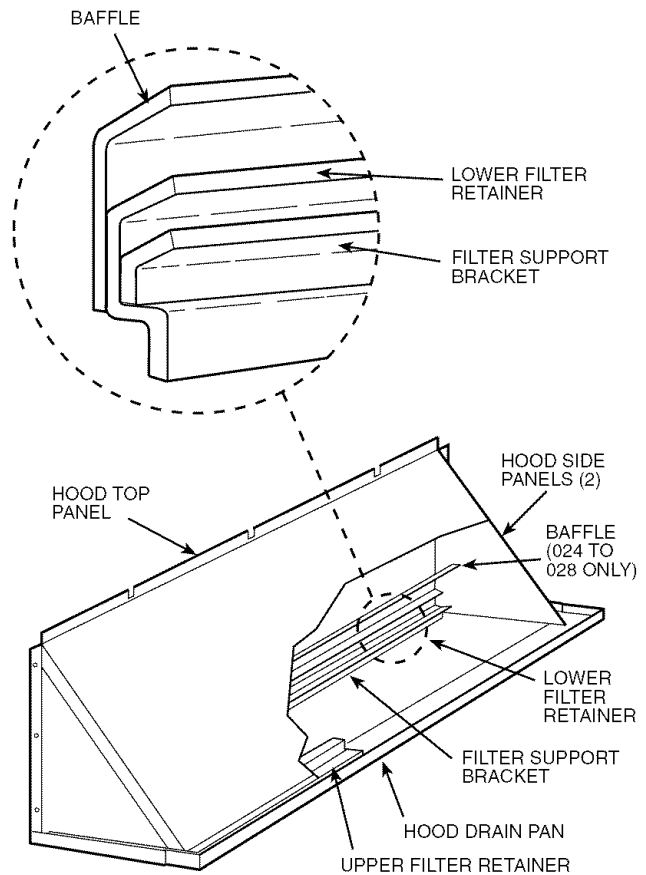

**Fig. 20 — Outdoor-Air Hood Details**

**Step 12 — Install All Accessories** — Install all field-installed accessories. Refer to the accessory installation instructions included with each accessory.

**MOTORMASTER® I CONTROL INSTALLATION**  
(48TJ016,020 UNITS)

**Install Field-Fabricated Wind Baffles** — Wind baffles must be field-fabricated for all units to ensure proper cooling cycle operation at low ambient temperatures. See Fig. 21 for baffle details. Use 20-gage, galvanized sheet metal, or similar corrosion-resistant metal for baffles. Use field-supplied screws to attach baffles to unit. Screws should be 1/4-in. diameter and 5/8-in. long. Drill required screw holes for mounting baffles.

**⚠ CAUTION**

To avoid damage to the refrigerant coils and electrical components, use recommended screw sizes only. Use care when drilling holes.

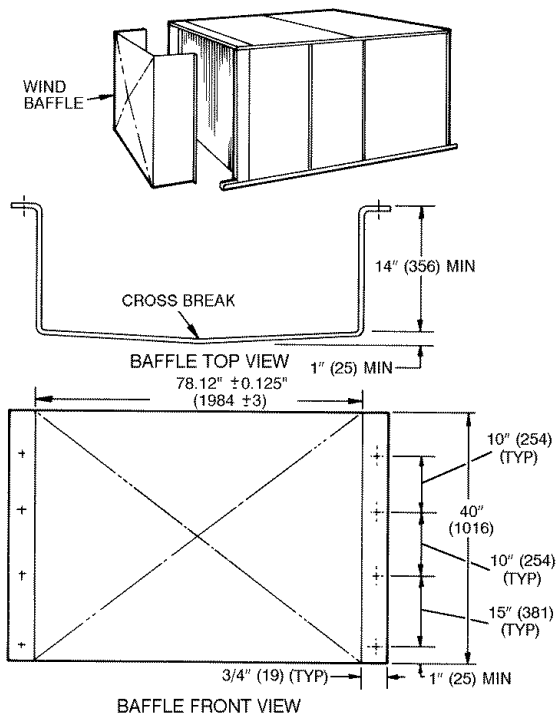

NOTE: Dimensions in ( ) are in mm.

**Fig. 21 — Wind Baffle Details**

**Install Motormaster I Controls** — Only one Motormaster I control is required per unit. The Motormaster I control must be used in conjunction with the Accessory 0° F Low Ambient Kit (purchased separately). The Motormaster I device controls outdoor fan no. 1 while outdoor fans no. 2 and 3 are sequenced off by the Accessory 0° F Low Ambient Kit.

**Accessory 0° F Low Ambient Kit** — Install the Accessory 0° F Low Ambient Kit per instruction supplied with accessory.

**Sensor Assembly** — Install the sensor assembly in the location shown in Fig. 22.

**Motor Mount** — To ensure proper fan height, replace the existing motor mount with the new motor mount provided with accessory.

**Transformer (460 and 575-v Units Only)** — On 460 and 575-v units, a transformer is required. The transformer is provided with the accessory and must be field-installed.

**Motormaster I Control** — Recommended mounting location is on the inside of the panel to the left of the control box. The control should be mounted on the inside of the panel, vertically, with leads protruding from bottom of extrusion.

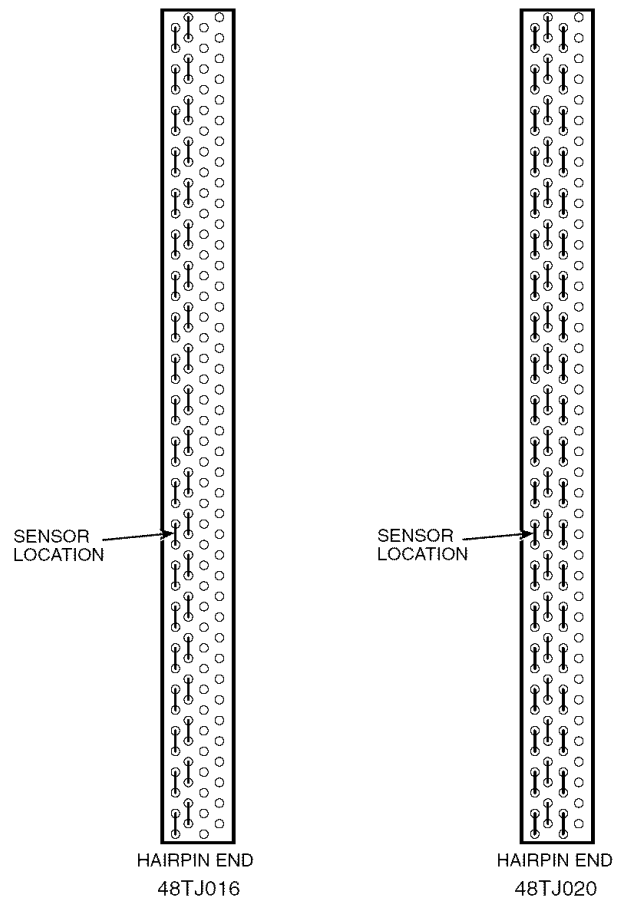

NOTE: All sensors are located on the eighth hairpin up from the bottom.

**Fig. 22 — Motormaster I Sensor Locations**

**MOTORMASTER® V CONTROL INSTALLATION**  
(48TJ024,028 UNITS)

**Install Field-Fabricated Wind Baffles** — Wind baffles must be field-fabricated for all units to ensure proper cooling cycle operation at low ambient temperatures. See Fig. 21 for baffle details. Use 20-gage, galvanized sheet metal, or similar corrosion-resistant metal for baffles. Use field-supplied screws to attach baffles to unit. Screws should be 1/4-in. diameter and 5/8-in. long. Drill required screw holes for mounting baffles.

**CAUTION**

To avoid damage to the refrigerant coils and electrical components, use recommended screw sizes only. Use care when drilling holes.

**Install Motormaster V Controls** — The Motormaster V (MMV) control is a motor speed control device which adjusts condenser fan motor speed in response to declining liquid refrigerant pressure. A properly applied Motormaster V control extends the operating range of air-conditioning systems and permits operation at lower outdoor ambient temperatures.

The minimum ambient temperatures at which the unit will operate are:

TEMPERATURE OPERATING LIMITS — F°		
Standard Unit	Unit with Low Ambient Kit	Unit with MMV Control
40	25	-20

To operate down to the ambient temperatures listed, Motormaster V controls (Fig. 23) must be added. Field-fabricated and installed wind baffles are also required for all units (see Fig. 21). The Motormaster V control permits operation of the unit to an ambient temperature of -20 F. The control regulates the speed of 3-phase fan motors that are compatible with the control. These motors are factory installed.

See Table 6 for the Motormaster V control accessory package usage. Table 7 shows applicable voltages and motors. Replacement of motor or fan blade **IS NOT REQUIRED ON CURRENT PRODUCTION UNITS** since the control is compatible with the factory-installed fan motors. Only field wiring control is required.

Install the Motormaster V control per instructions supplied with accessory.

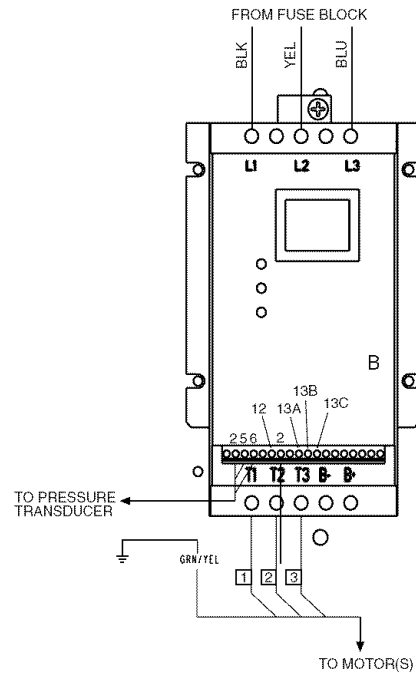

**Fig. 23 — Motormaster V Control**

**Table 6 — Motormaster V Control Package Usage**

UNIT	VOLTAGE	ITEM DESCRIPTION
48TJ024,028	208/230	CRLOWAMB015A00
	460	CRLOWAMB016A00
	575	CRLOWAMB017A00

**Table 7 — Applicable Voltages and Motors**

VOLTAGE	COMPATIBLE MOTOR
208/230-3-60	HD52AK654
460-3-60	HD52AK654
575-3-60	HD52GE576



### Step 13 — Adjust Factory-Installed Options

**PREMIERLINK™ CONTROL** — The PremierLink controller is available as a special order from the factory and is compatible with the Carrier Comfort Network® (CCN) system. This control is designed to allow users the access and ability to change factory-defined settings, thus expanding the function of the standard unit control board. Carrier's diagnostic standard tier display tools such as Navigator™ device or Scrolling Marquee can be used with the PremierLink controller.

The PremierLink controller (see Fig. 24) requires the use of a Carrier electronic thermostat or a CCN connection for time broadcast to initiate its internal timeclock. This is necessary for broadcast of time of day functions (occupied/unoccupied). No sensors are supplied with the field-mounted PremierLink control. The factory-installed PremierLink control includes only the supply-air temperature (SAT) sensor and the outdoor air temperature (OAT) sensor as standard. An indoor air quality (CO<sub>2</sub>) sensor can be added as an option. Refer to Table 8 for sensor usage. Refer to Fig. 25 for PremierLink controller wiring. The PremierLink control may be mounted in the control panel or an area below the control panel.

**NOTE:** PremierLink controller version 1.3 and later is shipped in Sensor mode. If used with a thermostat, the PremierLink controller must be configured to Thermostat mode.

**Install the Supply Air Temperature (SAT) Sensor** — When the unit is supplied with a factory-mounted PremierLink control, the supply-air temperature (SAT) sensor (33ZCSENSAT) is factory-supplied and wired. The wiring is routed from the PremierLink control over the control box, through a grommet,

into the fan section, down along the back side of the fan, and along the fan deck over to the supply-air opening.

The SAT probe is wire-tied to the supply-air opening (on the horizontal opening end) in its shipping position. Remove the sensor for installation. Re-position the sensor in the flange of the supply-air opening or in the supply air duct (as required by local codes). Drill or punch a 1/2-in. hole in the flange or duct. Use two field-supplied, self-drilling screws to secure the sensor probe in a horizontal orientation.

**NOTE:** The sensor must be mounted in the discharge airstream downstream of the cooling coil and any heating devices. Be sure the probe tip does not come in contact with any of the unit or heat surfaces.

**Outdoor Air Temperature (OAT) Sensor** — When the unit is supplied with a factory-mounted PremierLink control, the outdoor-air temperature sensor (OAT) is factory-supplied and wired.

**Install the Indoor Air Quality (CO<sub>2</sub>) Sensor** — Mount the optional indoor air quality (CO<sub>2</sub>) sensor according to manufacturer specifications.

A separate field-supplied transformer must be used to power the CO<sub>2</sub> sensor.

Wire the CO<sub>2</sub> sensor to the COM and IAQI terminals of J5 on the PremierLink controller. Refer to the PremierLink Installation, Start-up, and Configuration Instructions for detailed wiring and configuration information.

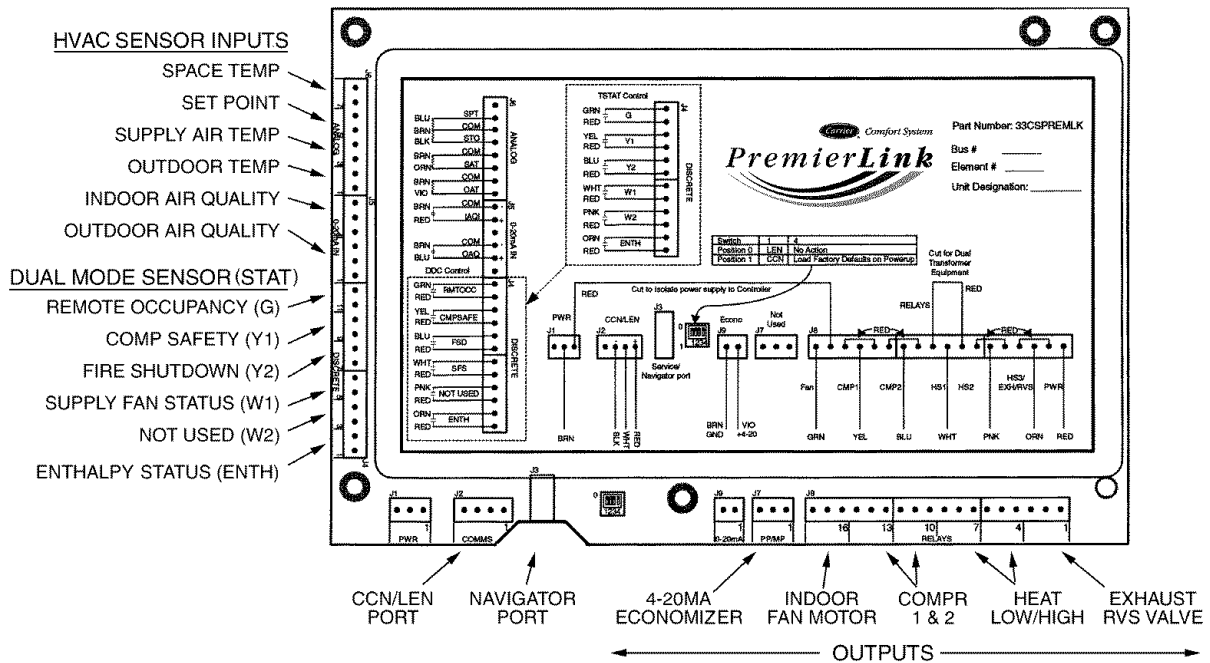
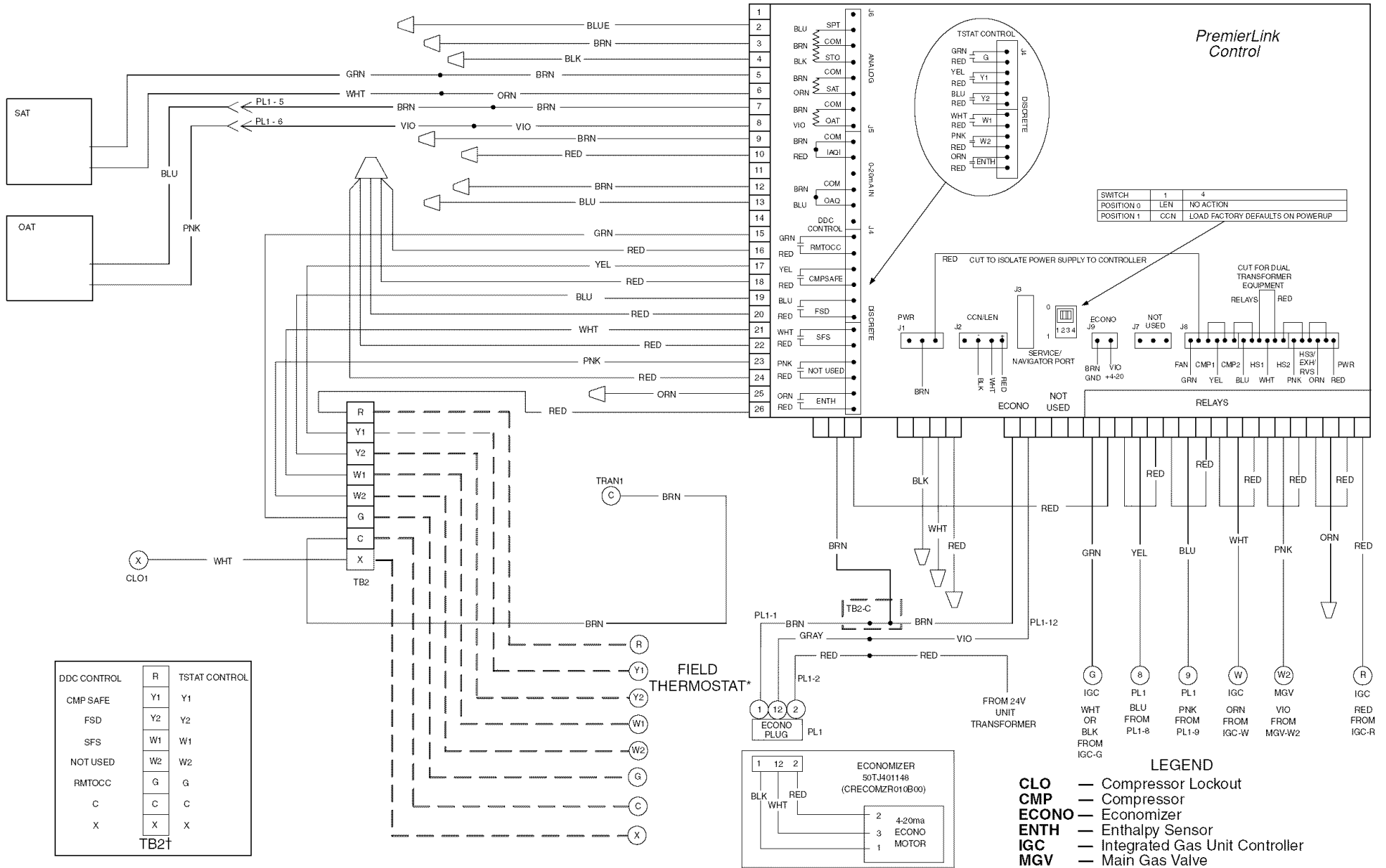

Fig. 24 — PremierLink Controller



\*If PremierLink control is in thermostat mode.  
 †TB2 terminal designations for 24 vac discrete inputs. Default is for DDC control.

Fig. 25 — PremierLink™ Controls Wiring

**Table 8 — PremierLink™ Sensor Usage**

APPLICATION	OUTDOOR AIR TEMPERATURE SENSOR	RETURN AIR TEMPERATURE SENSOR	OUTDOOR AIR ENTHALPY SENSOR	RETURN AIR ENTHALPY SENSOR
Differential Dry Bulb Temperature with PremierLink* (PremierLink requires 4-20 mA Actuator)	Included — HH79NZ039	Required — 33ZCT55SPT or Equivalent	—	—
Single Enthalpy with PremierLink* (PremierLink requires 4-20 mA Actuator)	Included — Not Used	—	Required — 33CSENTHSW (HH57ZC003) or HH57AC077	—
Differential Enthalpy with PremierLink* (PremierLink requires 4-20 mA Actuator)	Included — Not Used	—	Required — 33CSENTHSW (HH57ZC003) or HH57AC077	Required — 33CSENSEN or HH57AC078

\*PremierLink control requires supply air temperature sensor 33ZCSENSAT and outdoor air temperature sensor HH79NZ039 — Included with factory-installed PremierLink control; field-supplied and field-installed with field-installed PremierLink control.

**NOTES:**

- CO<sub>2</sub> Sensors (Optional):  
 33ZCSENSCO2 — Room sensor (adjustable). Aspirator box is required for duct mounting of the sensor.  
 33ZCASPCO2 — Aspirator box used for duct-mounted CO<sub>2</sub> room sensor.  
 33ZCT55CO2 — Space temperature and CO<sub>2</sub> room sensor with override.  
 33ZCT56CO2 — Space temperature and CO<sub>2</sub> room sensor with override and setpoint.
- All units include the following Standard Sensors:  
 Outdoor-air sensor — 50HJ540569 — Opens at 67 F, closes at 52 F, not adjustable.  
 Mixed-air sensor — HH97AZ001 — (PremierLink control requires supply air temperature sensor 33ZCSENSAT and outdoor air temperature sensor HH79NZ039)  
 Compressor lockout sensor — 50HJ540570 — Opens at 35 F, closes at 50 F.

**ENTHALPY SWITCH/RECEIVER** — The accessory enthalpy switch/receiver (33CSENTHSW) senses temperature and humidity of the air surrounding the device and calculates the enthalpy when used without an enthalpy sensor. The relay is energized when enthalpy is high and deenergized when enthalpy is low (based on ASHRAE [American Society of Heating, Refrigeration and Air Conditioning Engineers] 90.1 criteria). If an accessory enthalpy sensor (33CSENSEN) is attached to the return air sensor input, then differential enthalpy is calculated. The relay is energized when the enthalpy detected by the return air enthalpy sensor is less than the enthalpy at the enthalpy switch/receiver. The relay is deenergized when the enthalpy detected by the return air enthalpy sensor is greater than the enthalpy at the enthalpy switch/receiver (differential enthalpy control). See Fig. 26 and 27.

**OUTDOOR ENTHALPY CONTROL** (Fig. 28) — Outdoor enthalpy control requires only an enthalpy switch/receiver (33CSENTHSW). The enthalpy switch/receiver is mounted in the outdoor air inlet and calculates outdoor air enthalpy. The enthalpy switch/receiver energizes the relay output when the outdoor enthalpy is above 28 BTU/lb **OR** dry bulb temperature is above 75 F and is deenergized when the outdoor enthalpy is below 27 BTU/lb **AND** dry bulb temperature is below 74.5 F. The relay output is wired to the unit economizer which will open or close depending on the output of the switch.

**NOTE:** The enthalpy calculation is done using an average altitude of 1000 ft above sea level.

**Mounting** — Mount the enthalpy switch/receiver in a location where the outdoor air can be sampled (such as the outdoor air

intake). The enthalpy switch/receiver is not a NEMA 4 (National Electrical Manufacturers Association) enclosure and should be mounted in a location that is not exposed to outdoor elements such as rain or snow. Use two field-supplied no. 8 x 3/4-in. TEK screws. Insert the screws through the holes in the sides of the enthalpy switch/receiver.

**Wiring** — Carrier recommends the use of 18 to 22 AWG (American Wire Gage) twisted pair or shielded cable for all wiring. All connections must be made with 1/4-in. female spade connectors.

A 24-vac transformer is required to power the enthalpy switch/receiver; as shown in Fig. 29, the PremierLink™ board provides 24 vac. Connect the GND and 24 VAC terminals on the enthalpy switch/receiver to the terminals on the transformer. On some applications, the power from the economizer harness can be used to power the enthalpy switch/receiver. To power the enthalpy switch/receiver from the economizer harness, connect power of the enthalpy switch/receiver to the red and brown wires (1 and 4) on the economizer harness.

For connection to rooftop units with PremierLink™ control, connect the LOW Enthalpy terminal on the enthalpy switch/receiver to J4 — pin 2 of the PremierLink control on the HVAC unit. The switch can be powered through the PremierLink control board if desired. Wire the 24 VAC terminal on the enthalpy switch/receiver to J4 — pin 1 on the PremierLink control. Wire the GND terminal on the enthalpy switch/receiver to J1 — pin 2 on the PremierLink control. The HI Enthalpy terminal is not used. See Fig. 28.

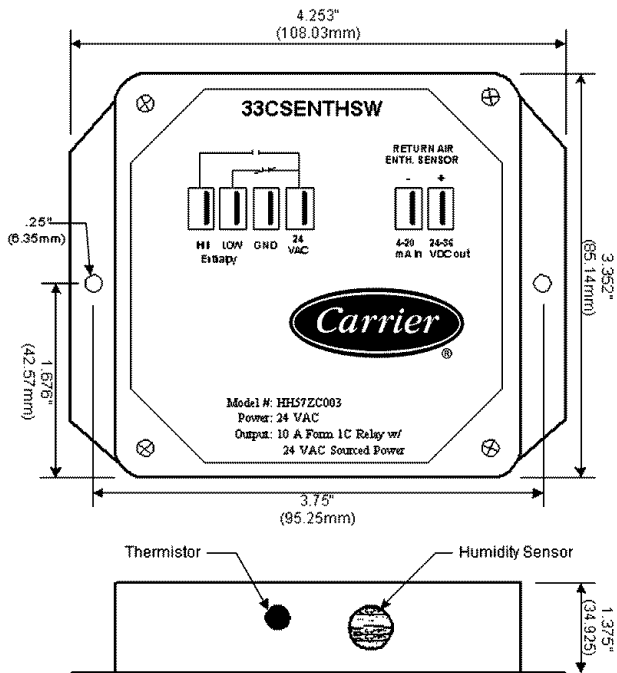

Fig. 26 — Enthalpy Switch/Receiver Dimensions (33CENTHSW)

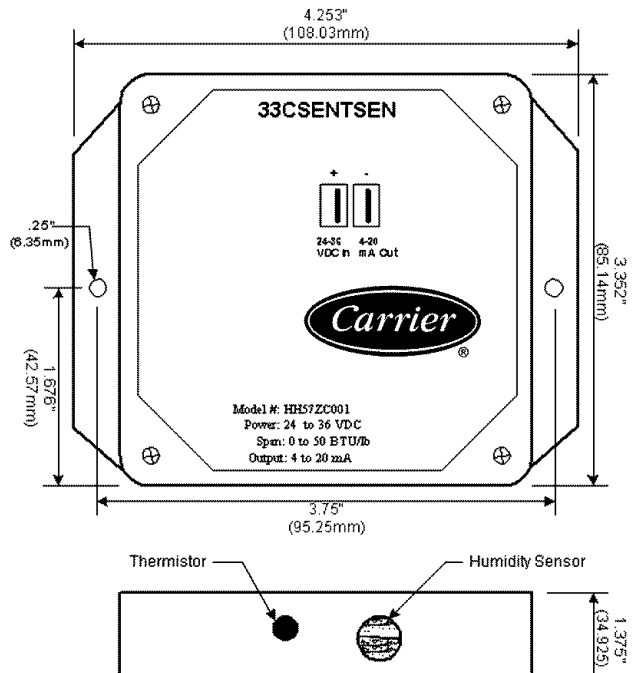

Fig. 27 — Enthalpy Sensor Dimensions (33CENTSEN)

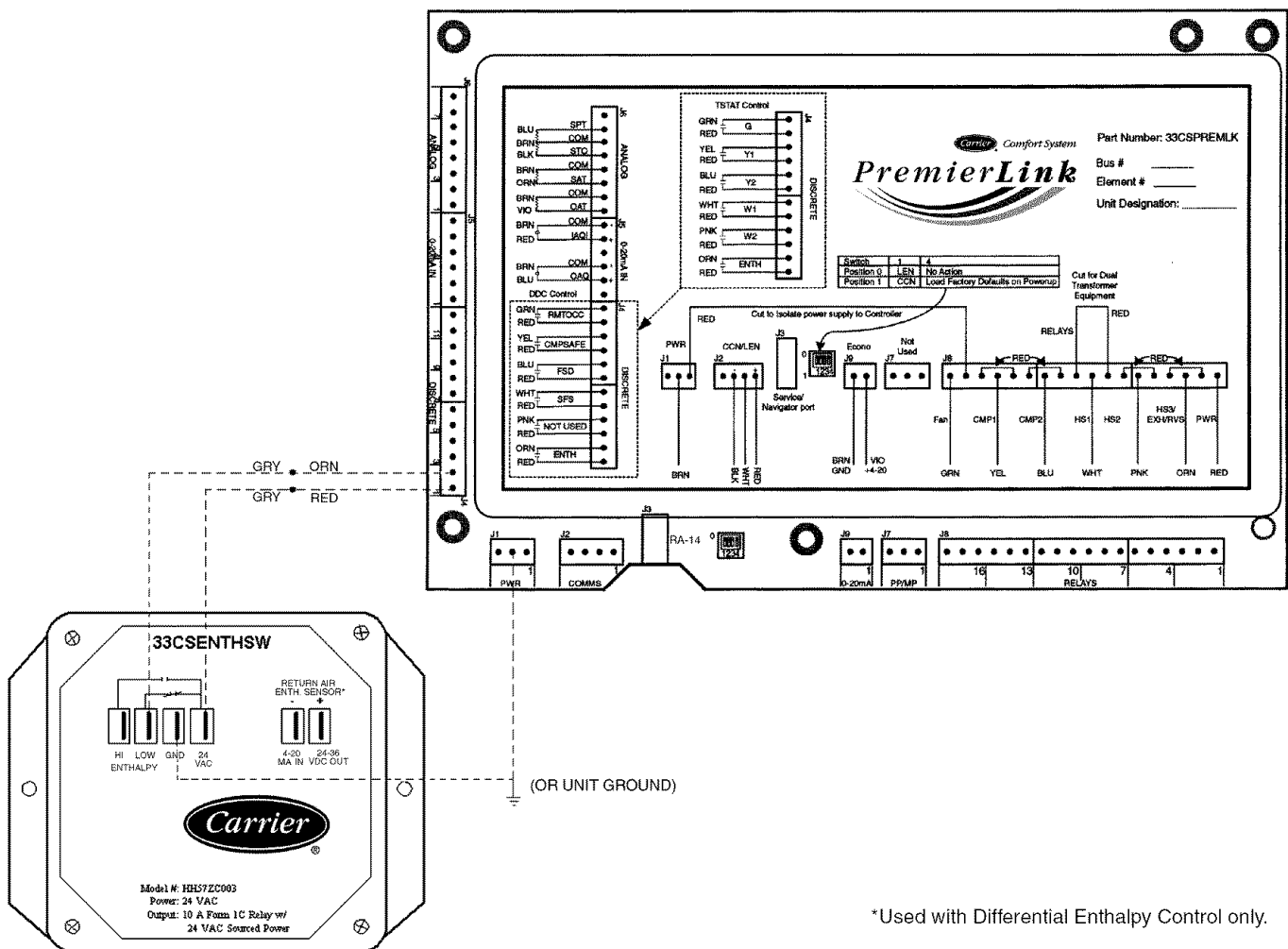

Fig. 28 — Typical Wiring Schematic — Carrier Rooftop Unit with PremierLink™ Controls

**DIFFERENTIAL ENTHALPY CONTROL (Fig. 29)** — Differential enthalpy control requires both an enthalpy switch/receiver (33CSENTHSW) and an enthalpy sensor (33CSENSEN). The enthalpy switch/receiver is mounted in the outdoor air inlet and calculates outdoor air enthalpy. The enthalpy sensor is mounted in the return airstream and calculates the enthalpy of the indoor air.

The enthalpy switch/receiver energizes the HI Enthalpy relay output when the outdoor enthalpy is greater than the indoor enthalpy. The LOW Enthalpy terminal is energized when the outdoor enthalpy is lower than the indoor enthalpy. The relay output is wired to the unit economizer which will open or close depending on the output of the switch.

**NOTE:** The enthalpy calculation is done using an average altitude of 1000 ft above sea level.

**Mounting** — Mount the enthalpy switch/receiver in a location where the outdoor air can be sampled (such as the outdoor air intake). The enthalpy switch/receiver is not a NEMA 4 enclosure and should be mounted in a location that is not exposed to outdoor elements such as rain, snow, or direct sunlight. Use two field-supplied no. 8 x 3/4-in. TEK screws. Insert the screws through the holes in the sides of the enthalpy switch/receiver.

Mount the enthalpy sensor in a location where the indoor air can be sampled (such as the return air duct). The enthalpy sensor is not a NEMA 4 enclosure and should be mounted in a location that is not exposed to outdoor elements such as rain or snow. Use two field-supplied no. 8 x 3/4-in. TEK screws. Insert the screws through the holes in the sides of the enthalpy sensor.

**Wiring** — Carrier recommends the use of 18 to 22 AWG twisted pair or shielded cable for all wiring. All connections must be made with 1/4-in. female spade connectors.

The PremierLink™ board provides 24-vac to power the enthalpy switch/receiver. Connect the GND and 24 VAC terminals on the enthalpy switch/receiver to the terminals on the transformer. On some applications, the power from the economizer harness can be used to power the enthalpy switch/receiver. To power the enthalpy switch/receiver from the economizer harness, connect power of the enthalpy switch/receiver to the red and brown wires (1 and 4) on the economizer harness.

Connect the LOW Enthalpy terminal on the enthalpy switch/receiver to J4 — pin 2 of the PremierLink control on the HVAC unit. The switch can be powered through the PremierLink control board if desired. Wire the 24VAC terminal on the enthalpy switch/receiver to J4 — pin 1 on the PremierLink control. Wire the GND terminal on the enthalpy switch/receiver to J1 — pin 2 on the PremierLink control. The HI Enthalpy terminal is not used. See Fig. 28.

Connect the 4-20 mA IN terminal on the enthalpy switch/receiver to the 4-20 mA OUT terminal on the return air enthalpy sensor. Connect the 24-36 VDC OUT terminal on the enthalpy switch/receiver to the 24-36 VDC IN terminal on the return air enthalpy sensor. See Fig. 29.

**Enthalpy Switch/Receiver Jumper Settings** — There are two jumpers. One jumper determines the mode of the enthalpy switch/receiver. The other jumper is not used. To access the jumpers, remove the 4 screws holding the cover on the enthalpy switch/receiver and then remove the cover. The factory settings for the jumpers are M1 and OFF.

The mode jumper should be set to M2 for differential enthalpy control. The factory test jumper should remain on OFF or the enthalpy switch/receiver will not calculate enthalpy.

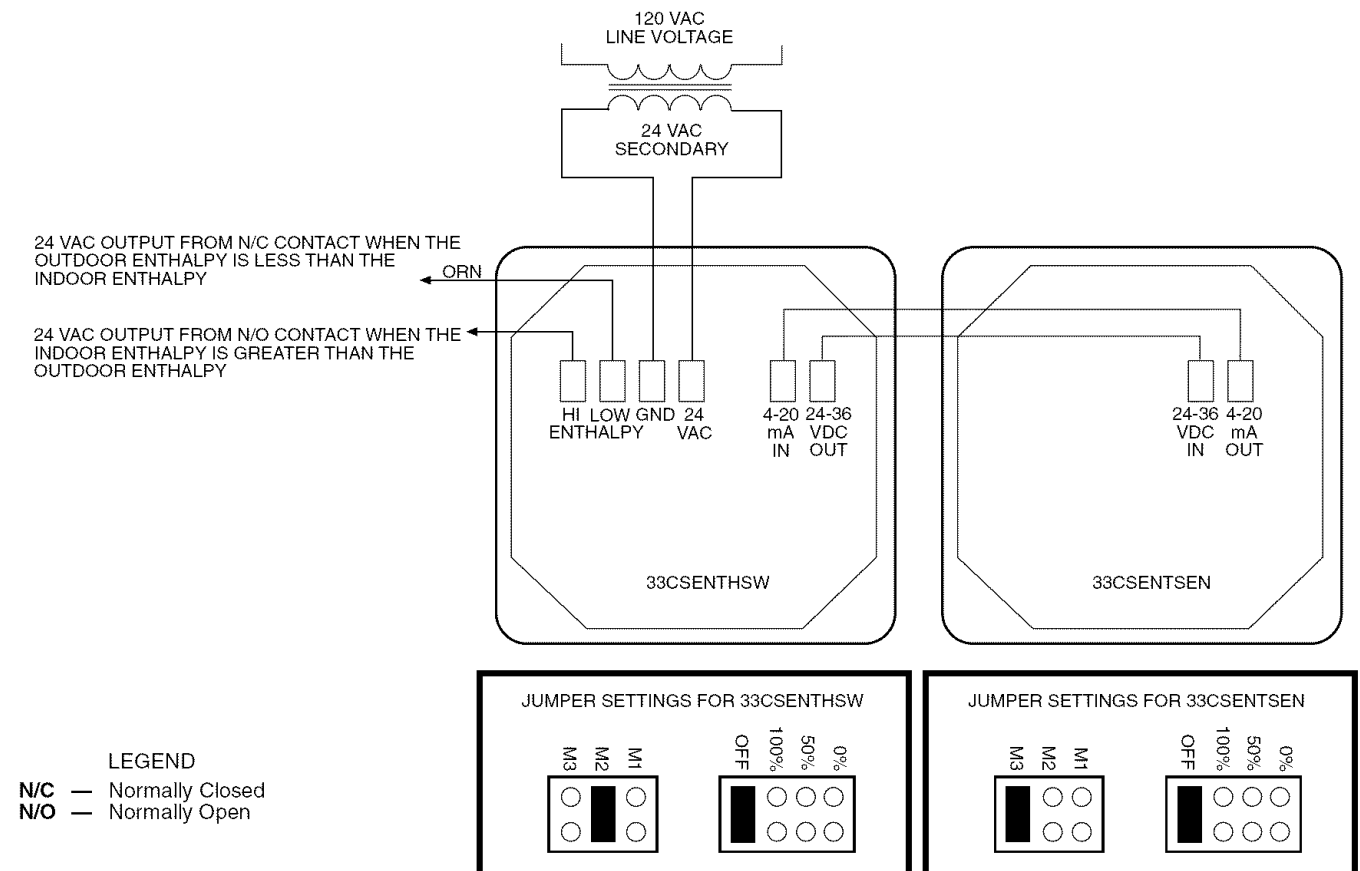

**Fig. 29 — Differential Enthalpy Control Wiring**

**Enthalpy Sensor Jumper Settings** — There are two jumpers. One jumper determines the mode of the enthalpy sensor. The other jumper is not used. To access the jumpers, remove the 4 screws holding the cover on the enthalpy sensor and then remove the cover. The factory settings for the jumpers are M3 and OFF.

The mode jumper should be set to M3 for 4 to 20 mA output. The factory test jumper should remain on OFF or the enthalpy sensor will not calculate enthalpy.

**ENTHALPY SENSORS AND CONTROL** — The enthalpy control (HH57AC077) is supplied as a field-installed accessory to be used with the EconoMi\$er2 damper control option. The outdoor air enthalpy sensor is part of the enthalpy control. The separate field-installed accessory return air enthalpy sensor (HH57AC078) is required for differential enthalpy control.

**NOTE:** The enthalpy control must be set to the “D” setting for differential enthalpy control to work properly.

The enthalpy control receives the indoor and return air enthalpy from the outdoor and return air enthalpy sensors and provides a dry contact switch input to the PremierLink™ controller. Locate the controller in place of an existing economizer controller or near the actuator. The mounting plate may not be needed if existing bracket is used.

A closed contact indicates that outside air is preferred to the return air. An open contact indicates that the economizer should remain at minimum position.

**Outdoor Air Enthalpy Sensor/Enthalpy Controller (HH57AC077)** — To wire the outdoor air enthalpy sensor, perform the following (see Fig. 30 and 31):

**NOTE:** The outdoor air sensor can be removed from the back of the enthalpy controller and mounted remotely.

1. Use a 4-conductor, 18 or 20 AWG cable to connect the enthalpy control to the PremierLink controller and power transformer.
2. Connect the following 4 wires from the wire harness located in rooftop unit to the enthalpy controller:
  - a. Connect the BRN wire to the 24 vac terminal (TR1) on enthalpy control and to pin 1 on 12-pin harness.
  - b. Connect the RED wire to the 24 vac GND terminal (TR) on enthalpy sensor and to pin 4 on 12-pin harness.
  - c. Connect the GRAY/ORN wire to J4-2 on Premier-Link controller and to terminal (3) on enthalpy sensor.
  - d. Connect the GRAY/RED wire to J4-1 on Premier-Link controller and to terminal (2) on enthalpy sensor.

**NOTE:** If installing in a Carrier rooftop, use the two gray wires provided from the control section to the economizer to connect PremierLink controller to terminals 2 and 3 on enthalpy sensor.

**Return Air Enthalpy Sensor** — Mount the return-air enthalpy sensor (HH57AC078) in the return-air duct. The return air sensor is wired to the enthalpy controller (HH57AC077). The outdoor enthalpy changeover set point is set at the controller.

To wire the return air enthalpy sensor, perform the following (see Fig. 30):

1. Use a 2-conductor, 18 or 20 AWG, twisted pair cable to connect the return air enthalpy sensor to the enthalpy controller.

2. At the enthalpy control remove the factory-installed resistor from the (SR) and (+) terminals.
3. Connect the field-supplied RED wire to (+) spade connector on the return air enthalpy sensor and the (SR+) terminal on the enthalpy controller. Connect the BLK wire to (S) spade connector on the return air enthalpy sensor and the (SR) terminal on the enthalpy controller.

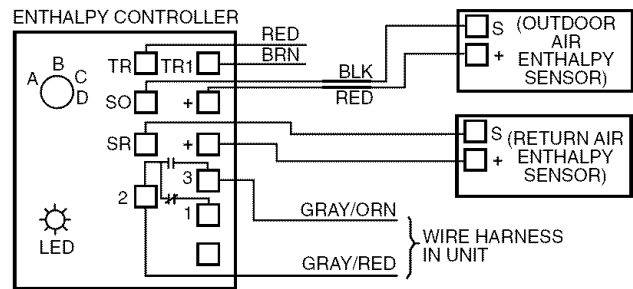

**NOTES:**

1. Remove factory-installed jumper across SR and + before connecting wires from return air sensor.
2. Switches shown in high outdoor air enthalpy state. Terminals 2 and 3 close on low outdoor air enthalpy relative to indoor air enthalpy.
3. Remove sensor mounted on back of control and locate in outside airstream.

**Fig. 30 — Outdoor and Return Air Sensor Wiring Connections for Differential Enthalpy Control**

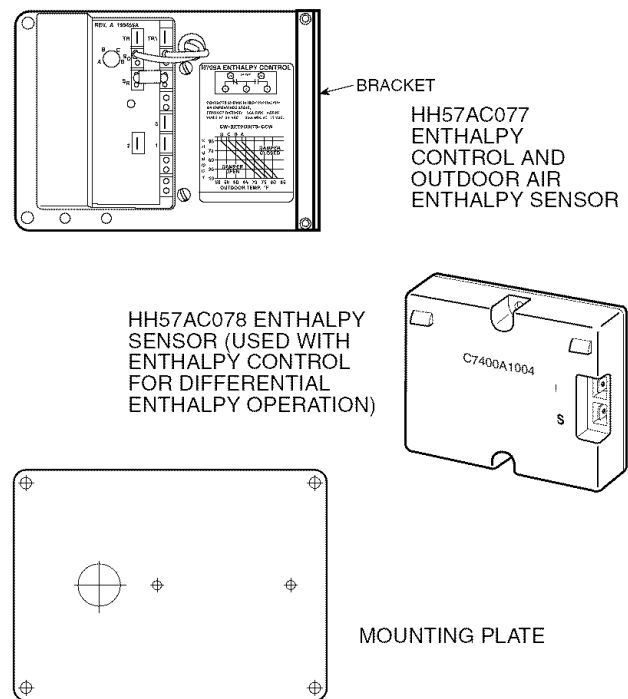

**Fig. 31 — Differential Enthalpy Control, Sensor and Mounting Plate (33AMKITENT006)**

OPTIONAL ECONOMISERIV AND ECONOMISER2 — See Fig. 32 and 33 for EconoMiSerIV component locations. See Fig. 34 for EconoMiSer2 component locations.

NOTE: These instructions are for installing the optional EconoMiSerIV and EconoMiSer2 only. Refer to the accessory EconoMiSerIV or EconoMiSer2 installation instructions when field installing an EconoMiSerIV or EconoMiSer2 accessory.

To complete installation of the optional EconoMiSerIV, perform the following procedure.

1. Remove the EconoMiSerIV hood. Refer to Step 11 — Install Outdoor-Air Hood on page 14 for information on removing and installing the outdoor-air hood.
2. Relocate outdoor air temperature sensor from shipping position to operation position on EconoMiSerIV. See Fig. 32.

**IMPORTANT:** Failure to relocate the sensor will result in the EconoMiSerIV not operating properly.

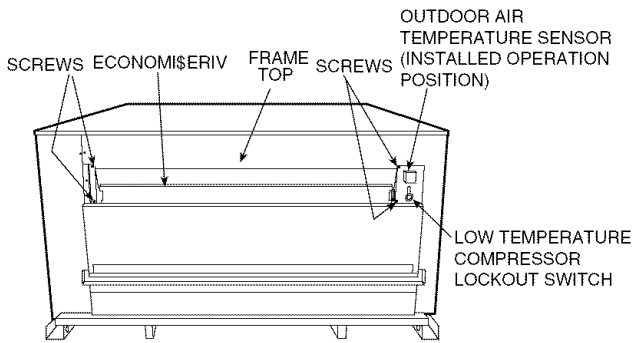

**Fig. 32 — EconoMiSerIV Component Locations — End View**

3. Reinstall economizer hood.
4. Install all EconoMiSerIV accessories. EconoMiSerIV wiring is shown in Fig. 35. EconoMiSer2 wiring is shown in Fig. 36.

Outdoor air leakage is shown in Table 9. Return air pressure drop is shown in Table 10.

**Table 9 — Outdoor Air Damper Leakage**

LEAKAGE (cfm)	DAMPER STATIC PRESSURE (in. wg)					
	0.2	0.4	0.6	0.8	1.0	1.2
35	53	65	75	90	102	

**Table 10 — Return Air Pressure Drop (in. wg)**

CFM									
4500	5000	5400	6000	7200	7500	9000	10,000	11,250	
0.040	0.050	0.060	0.070	0.090	0.100	0.110	0.120	0.140	

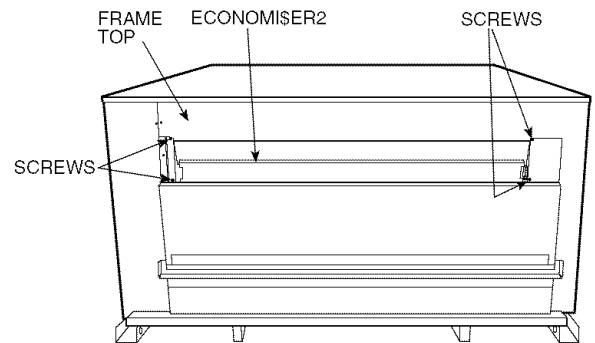

**Fig. 34 — EconoMiSer2 Component Locations**

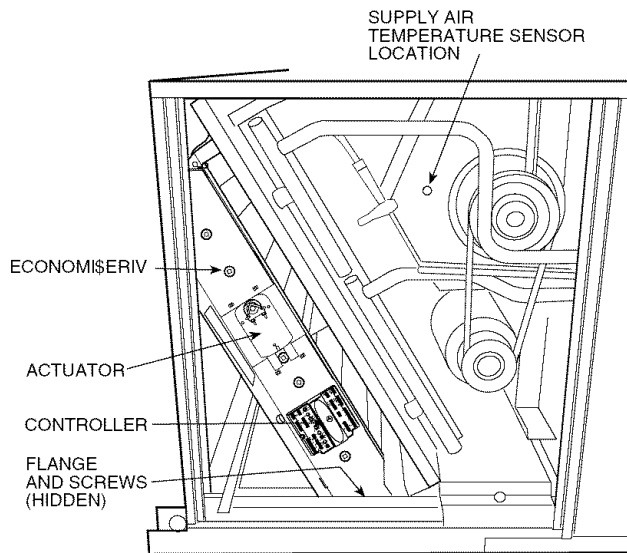

**Fig. 33 — EconoMiSerIV Component Locations — Side View**

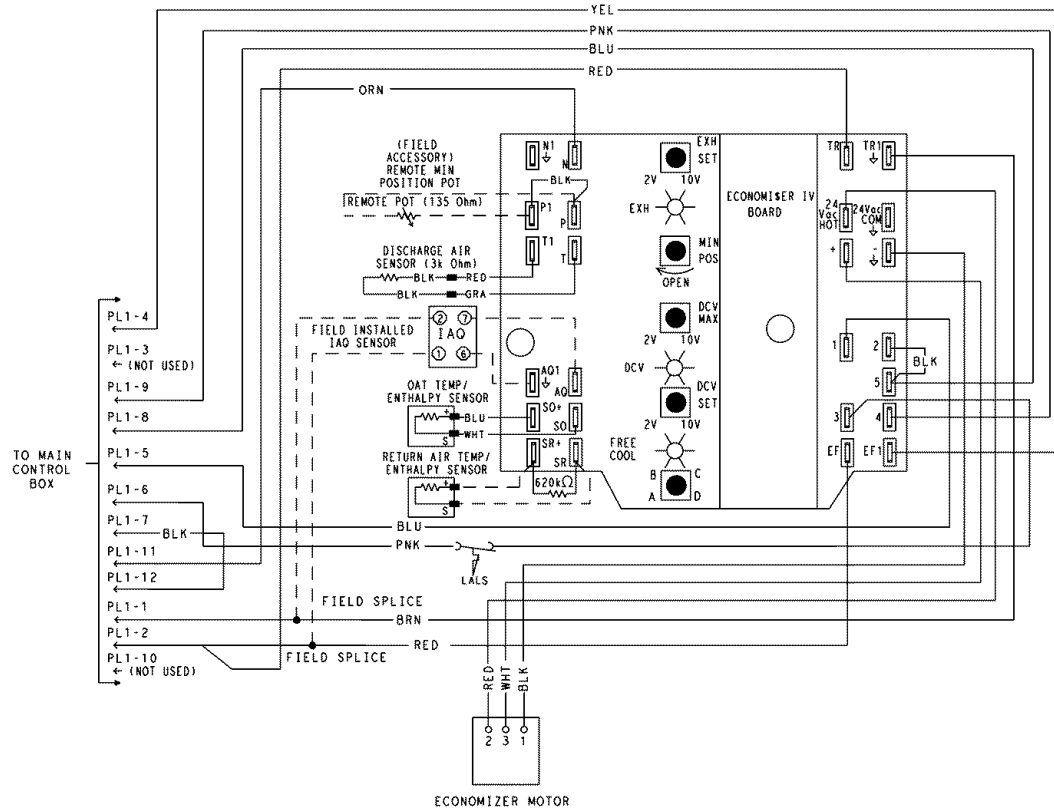

**LEGEND**  
**DCV** — Demand Controlled Ventilation  
**IAQ** — Indoor Air Quality  
**LALS** — Low Temperature Compressor Lockout Switch  
**OAT** — Outdoor-Air Temperature  
**POT** — Potentiometer

**Potentiometer Default Settings:**  
 Power Exhaust Middle  
 Minimum Pos. Fully Closed  
 DCV Max. Middle  
 DCV Set Middle  
 Enthalpy C Setting

**NOTES:**  
 1. 620 ohm, 1 watt 5% resistor should be removed only when using differential enthalpy or dry bulb.  
 2. If a separate field-supplied 24 v transformer is used for the IAQ sensor power supply, it cannot have the secondary of the transformer grounded.  
 3. For field-installed remote minimum position POT, remove black wire jumper between P and P1 and set control minimum position POT to the minimum position.

**Fig. 35 — EconoMiSerIV Wiring**

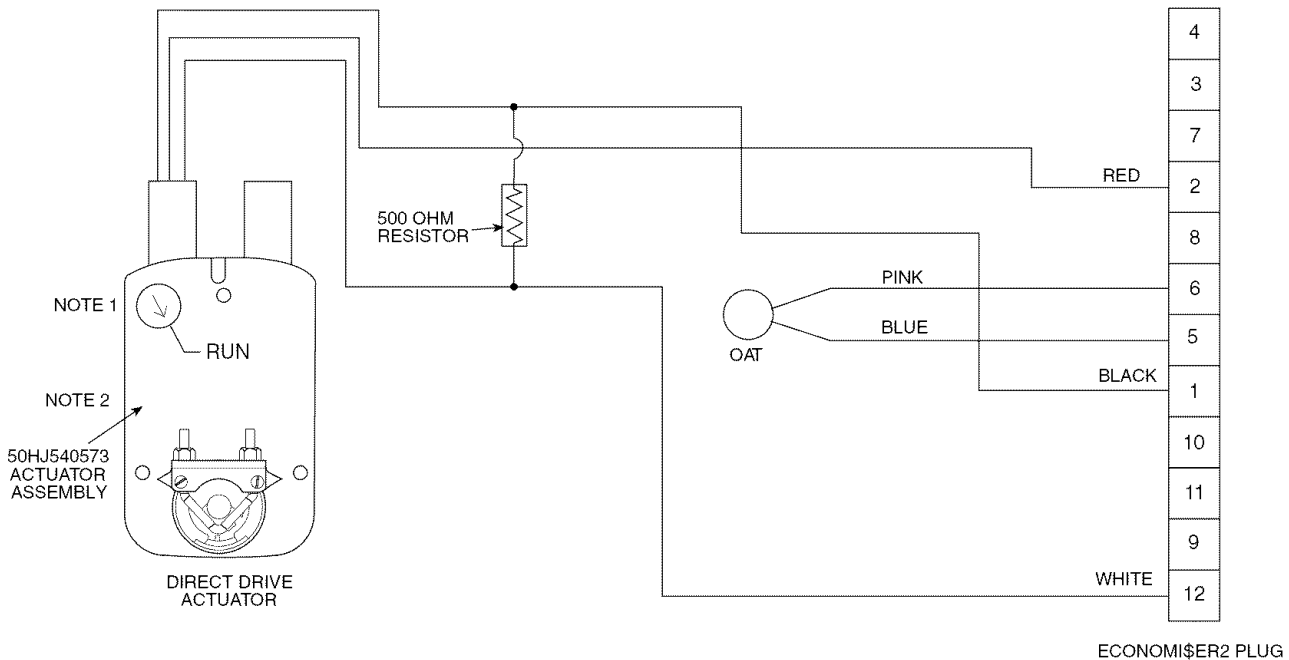

**LEGEND**  
**OAT** — Outdoor Air Temperature Sensor

**NOTES:**  
 1. Switch on actuator must be in run position for economizer to operate.  
 2. 50HJ540573 actuator consists of the 50HJ540567 actuator and a harness with 500-ohm resistor.

**Fig. 36 — EconoMiSer2 Wiring**



## ECONOMISERIV STANDARD SENSORS

**Outdoor Air Temperature (OAT) Sensor** — The outdoor air temperature sensor (HH57AC074) is a 10 to 20 mA device used to measure the outdoor-air temperature. The outdoor-air temperature is used to determine when the EconoMiSerIV can be used for free cooling. The sensor must be field-relocated. See Fig. 32. The operating range of temperature measurement is 40 to 100 F.

**Supply Air Temperature (SAT) Sensor** — The supply air temperature sensor is a 3 K thermistor located at the inlet of the indoor fan. See Fig. 33. This sensor is factory installed. The operating range of temperature measurement is 0° to 158 F. See Table 11 for sensor temperature/resistance values.

The temperature sensor looks like an eyelet terminal with wires running to it. The sensor is located in the “crimp end” and is sealed from moisture.

**Low Temperature Compressor Lockout Switch** — The EconoMiSerIV is equipped with an ambient temperature lockout switch located in the outdoor airstream which is used to lockout the compressors below a 42 F ambient temperature. See Fig. 32.

**Table 11 — Supply Air Sensor Temperature/Resistance Values**

TEMPERATURE (F)	RESISTANCE (ohms)
-58	200,250
-40	100,680
-22	53,010
-4	29,091
14	16,590
32	9,795
50	5,970
68	3,747
77	3,000
86	2,416
104	1,597
122	1,080
140	746
158	525
176	376
185	321
194	274
212	203
230	153
248	116
257	102
266	89
284	70
302	55

## ECONOMISERIV CONTROL MODES

**IMPORTANT:** The optional EconoMiSer2 does not include a controller. The EconoMiSer2 is operated by a 4 to 20 mA signal from an existing field-supplied controller (such as PremierLink™ control). See Fig. 36 for wiring information.

Determine the EconoMiSerIV control mode before set up of the control. Some modes of operation may require different sensors. Refer to Table 12. The EconoMiSerIV is supplied from the factory with a supply air temperature sensor, a low temperature compressor lockout switch, and an outdoor air temperature sensor. This allows for operation of the EconoMiSerIV with outdoor air dry bulb changeover control. Additional accessories can be added to allow for different types of changeover control and operation of the EconoMiSerIV and unit.

**Table 12 — EconoMiSerIV Sensor Usage**

APPLICATION	ECONOMISERIV WITH OUTDOOR AIR DRY BULB SENSOR	
	Accessories Required	
Outdoor Air Dry Bulb	None. The outdoor air dry bulb sensor is factory installed.	
Differential Dry Bulb	CRTEMPSN002A00*	
Single Enthalpy	HH57AC078	
Differential Enthalpy	HH57AC078 and CRENTDIF004A00*	
CO <sub>2</sub> for DCV Control using a Wall-Mounted CO <sub>2</sub> Sensor	33ZCSENCO2	
CO <sub>2</sub> for DCV Control using a Duct-Mounted CO <sub>2</sub> Sensor	33ZCSENCO2† and 33ZCASPCO2**	CRCBDIOX005A00††

\*CRENTDIF004A00 and CRTEMPSN002A00 accessories are used on many different base units. As such, these kits may contain parts that will not be needed for installation.

†33ZCSENCO2 is an accessory CO<sub>2</sub> sensor.

\*\*33ZCASPCO2 is an accessory aspirator box required for duct-mounted applications.

††CRCBDIOX005A00 is an accessory that contains both 33ZCSENCO2 and 33ZCASPCO2 accessories.

**Outdoor Dry Bulb Changeover** — The standard controller is shipped from the factory configured for outdoor dry bulb changeover control. The outdoor air and supply air temperature sensors are included as standard. For this control mode, the outdoor temperature is compared to an adjustable set point selected on the control. If the outdoor-air temperature is above the set point, the EconoMiSerIV will adjust the outdoor-air dampers to minimum position. If the outdoor-air temperature is below the set point, the position of the outdoor-air dampers will be controlled to provide free cooling using outdoor air. When in this mode, the LED next to the free cooling set point potentiometer will be on. The changeover temperature set point is controlled by the free cooling set point potentiometer located on the control. See Fig. 37. The scale on the potentiometer is A, B, C, and D. See Fig. 38 for the corresponding temperature changeover values.

**Differential Dry Bulb Control** — For differential dry bulb control the standard outdoor dry bulb sensor is used in conjunction with an additional accessory return air sensor (part number CRTEMPSN002A00). The accessory sensor must be mounted in the return airstream. See Fig. 39.

In this mode of operation, the outdoor-air temperature is compared to the return-air temperature and the lower temperature airstream is used for cooling. When using this mode of changeover control, turn the free cooling/enthalpy set point potentiometer fully clockwise to the D setting. See Fig. 37.

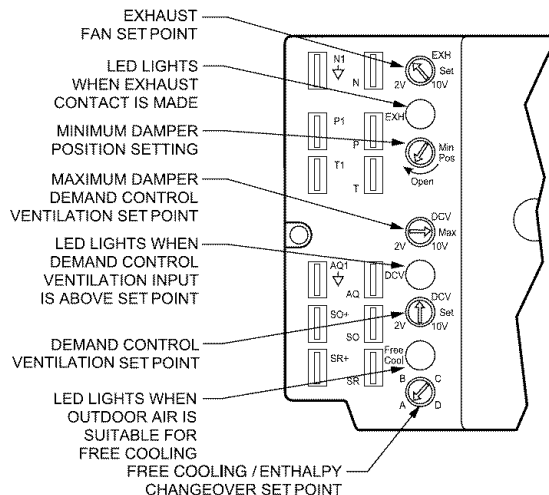

**Fig. 37 — EconoMiSerIV Controller Potentiometer and LED Locations**

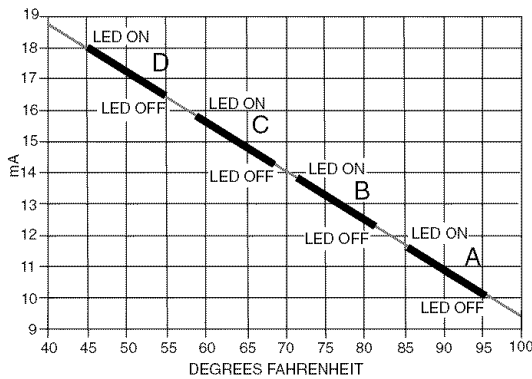

**Fig. 38 — Outside Air Temperature Changeover Set Points**

**Outdoor Enthalpy Changeover** — For enthalpy control, accessory enthalpy sensor (part number HH57AC078) is required. Replace the standard outdoor dry bulb temperature sensor with the accessory enthalpy sensor in the same mounting location. See Fig. 32. When the outdoor air enthalpy rises above the outdoor enthalpy changeover set point, the outdoor-air damper moves to its minimum position. The outdoor enthalpy changeover set point is set with the outdoor enthalpy set point potentiometer on the EconoMi\$erIV controller. The set points are A, B, C, and D. See Fig. 40. The factory-installed 620-ohm jumper must be in place across terminals SR and SR+ on the EconoMi\$erIV controller. See Fig. 32 and 41.

**Differential Enthalpy Control** — For differential enthalpy control, the EconoMi\$erIV controller uses two enthalpy sensors (HH57AC078 and CRENTDIF004A00), one in the outside air and one in the return airstream or the EconoMi\$erIV frame. The EconoMi\$erIV controller compares the outdoor air enthalpy to the return air enthalpy to determine EconoMi\$erIV use. The controller selects the lower enthalpy air (return or outdoor) for cooling. For example, when the outdoor air has a lower enthalpy than the return air and is below the set point, the EconoMi\$erIV opens to bring in outdoor air for free cooling.

Replace the standard outside air dry bulb temperature sensor with the accessory enthalpy sensor in the same mounting location. See Fig. 32. Mount the return air enthalpy sensor in the return airstream. See Fig. 39. The outdoor enthalpy changeover set point is set with the outdoor enthalpy set point potentiometer on the EconoMi\$erIV controller. When using this mode of changeover control, turn the enthalpy set point potentiometer fully clockwise to the D setting.

NOTE: Remove 620-ohm resistor if differential enthalpy sensor is installed.

**Indoor Air Quality (IAQ) Sensor Input** — The IAQ input can be used for demand control ventilation control based on the level of CO<sub>2</sub> measured in the space or return air duct.

Mount the accessory IAQ sensor according to manufacturer specifications. The IAQ sensor should be wired to the AQ and AQ1 terminals of the controller. Adjust the DCV potentiometers to correspond to the DCV voltage output of the indoor air quality sensor at the user-determined set point. See Fig. 42.

If a separate field-supplied transformer is used to power the IAQ sensor, the sensor must not be grounded or the EconoMi\$erIV control board will be damaged.

**Exhaust Set Point Adjustment** — The exhaust set point will determine when the exhaust fan runs based on damper position (if accessory power exhaust is installed). The set point is modified with the Exhaust Fan Set Point (EXH SET) potentiometer. See Fig. 37. The set point represents the damper position above which the exhaust fan will be turned on. When there is a call for exhaust, the EconoMi\$erIV controller provides a

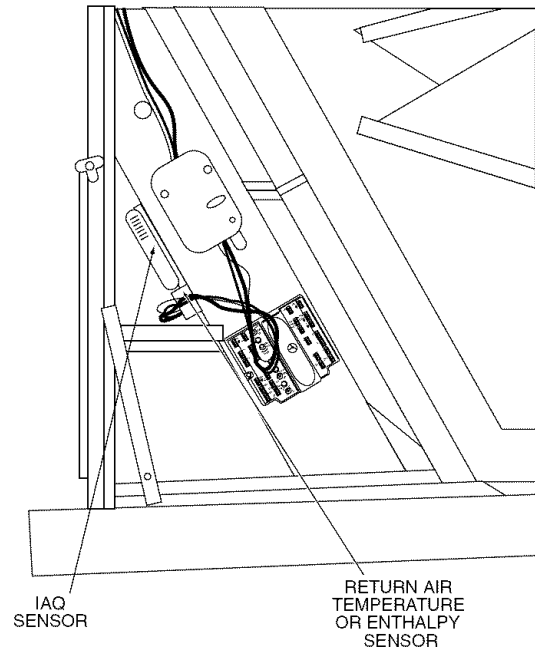

**Fig. 39 — Return Air Temperature or Enthalpy Sensor Mounting Location**

45 ± 15 second delay before exhaust fan activation to allow the dampers to open. This delay allows the damper to reach the appropriate position to avoid unnecessary fan overload.

**Minimum Position Control** — There is a minimum damper position potentiometer on the EconoMi\$erIV controller. See Fig. 37. The minimum damper position maintains the minimum airflow into the building during the occupied period.

When using demand ventilation, the minimum damper position represents the minimum ventilation position for VOC (volatile organic compound) ventilation requirements. The maximum demand ventilation position is used for fully occupied ventilation.

When demand ventilation control is not being used, the minimum position potentiometer should be used to set the occupied ventilation position. The maximum demand ventilation position should be turned fully clockwise.

Adjust the minimum position potentiometer to allow the minimum amount of outdoor air, as required by local codes, to enter the building. Make minimum position adjustments with at least 10° F temperature difference between the outdoor and return-air temperatures.

To determine the minimum position setting, perform the following procedure:

1. Calculate the appropriate mixed-air temperature using the following formula:

$$(T_O \times \frac{OA}{100}) + (T_R \times \frac{RA}{100}) = T_M$$

T<sub>O</sub> = Outdoor-Air Temperature

OA = Percent of Outdoor Air

T<sub>R</sub> = Return-Air Temperature

RA = Percent of Return Air

T<sub>M</sub> = Mixed-Air Temperature

As an example, if local codes require 10% outdoor air during occupied conditions, outdoor-air temperature is 60 F, and return-air temperature is 75 F.

$$(60 \times .10) + (75 \times .90) = 73.5 \text{ F}$$

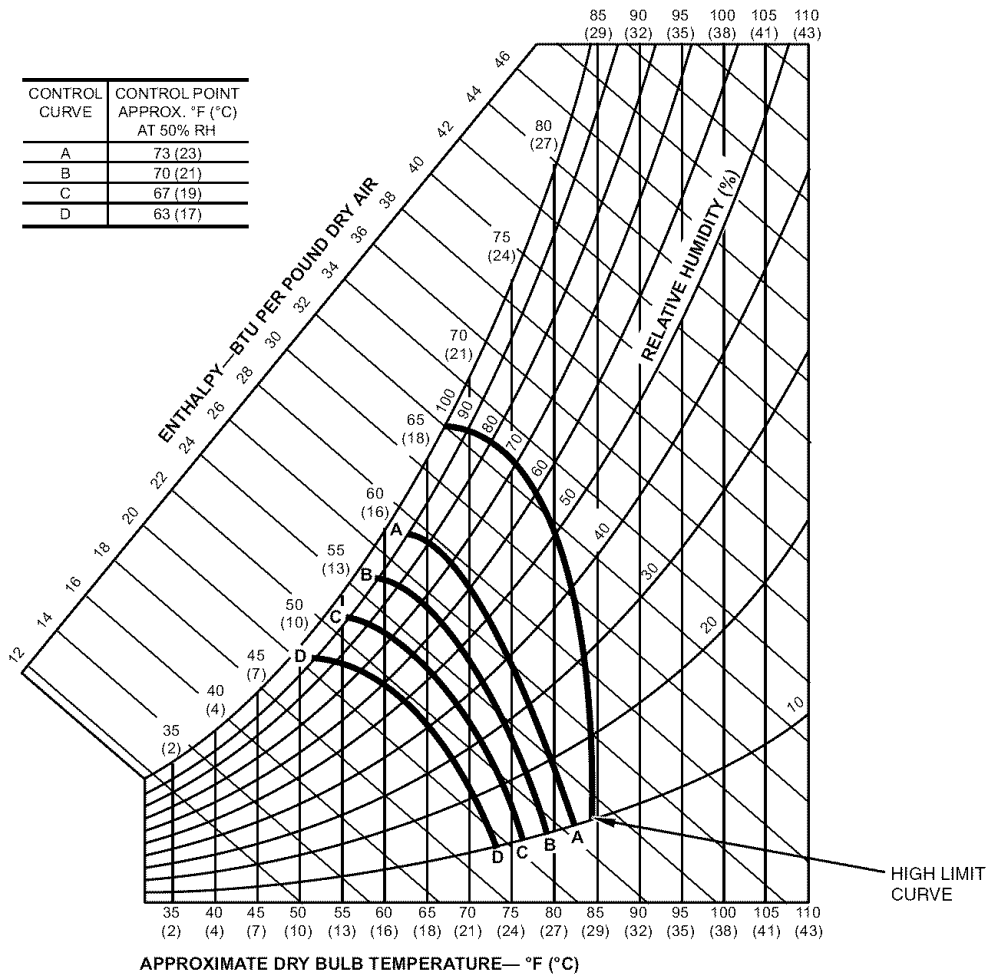

**Fig. 40 — Enthalpy Changeover Set Points**

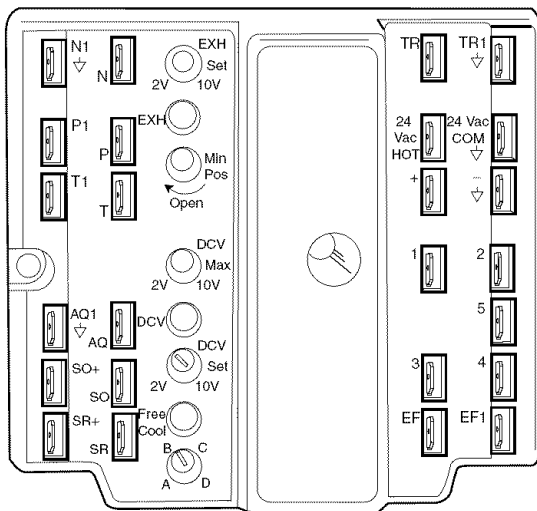

**Fig. 41 — EconMiSerIV Controller**

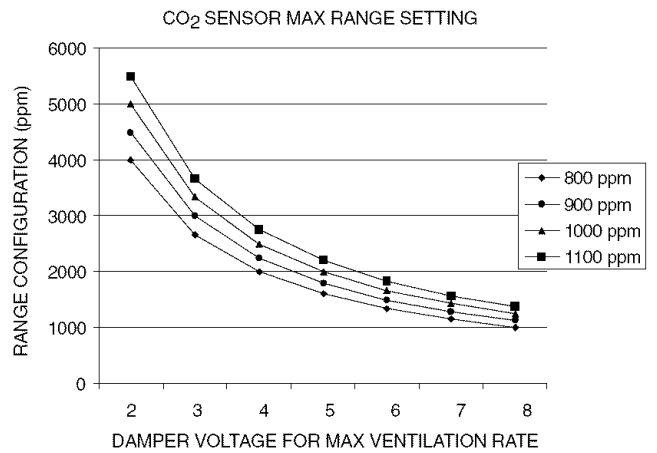

**Fig. 42 — CO<sub>2</sub> Sensor Maximum Range Setting**

2. Disconnect the supply-air sensor from terminals T and T1.
3. Ensure that the factory-installed jumper is in place across terminals P and P1. If remote damper positioning is being used, make sure that the terminals are wired according to Fig. 35 and that the minimum position potentiometer is turned fully clockwise.
4. Connect 24 vac across terminals TR and TR1.
5. Carefully adjust the minimum position potentiometer until the measured mixed-air temperature matches the calculated value.
6. Reconnect the supply-air sensor to terminals T and T1.

Remote control of the EconoMi\$erIV damper is desirable when requiring additional temporary ventilation. If a field-supplied remote potentiometer (Honeywell part number S963B1128) is wired to the EconoMi\$erIV controller, the minimum position of the damper can be controlled from a remote location.

To control the minimum damper position remotely, remove the factory-installed jumper on the P and P1 terminals on the EconoMi\$erIV controller. Wire the field-supplied potentiometer to the P and P1 terminals on the EconoMi\$erIV controller. See Fig. 41.

**Damper Movement** — Damper movement from full open to full closed (or vice versa) takes 2½ minutes.

**Thermostats** — The EconoMi\$erIV control works with conventional thermostats that have a Y1 (cool stage 1), Y2 (cool stage 2), W1 (heat stage 1), W2 (heat stage 2), and G (fan). The EconoMi\$erIV control does not support space temperature sensors. Connections are made at the thermostat terminal connection board located in the main control box.

**Occupancy Control** — The factory default configuration for the EconoMi\$erIV control is occupied mode. Occupied status is provided by the red jumper from terminal 9 to terminal 10 on TB2. When unoccupied mode is desired, install a field-supplied timeclock function in place of the jumper between terminals 9 and 10 on TB2. See Fig. 35. When the timeclock contacts are closed, the EconoMi\$erIV control will be in occupied mode. When the timeclock contacts are open (removing the 24-v signal from terminal N), the EconoMi\$erIV will be in unoccupied mode.

**Demand Controlled Ventilation (DCV)** — When using the EconoMi\$erIV for demand controlled ventilation, there are some equipment selection criteria which should be considered. When selecting the heat capacity and cool capacity of the equipment, the maximum ventilation rate must be evaluated for design conditions. The maximum damper position must be calculated to provide the desired fresh air.

Typically the maximum ventilation rate will be about 5 to 10% more than the typical cfm required per person, using normal outside air design criteria.

A proportional anticipatory strategy should be taken with the following conditions: a zone with a large area, varied occupancy, and equipment that cannot exceed the required ventilation rate at design conditions. Exceeding the required ventilation rate means the equipment can condition air at a maximum ventilation rate that is greater than the required ventilation rate for maximum occupancy. A proportional-anticipatory strategy will cause the fresh air supplied to increase as the room CO<sub>2</sub> level increases even though the CO<sub>2</sub> set point has not been reached. By the time the CO<sub>2</sub> level reaches the set point, the damper will be at maximum ventilation and should maintain the set point.

In order to have the CO<sub>2</sub> sensor control the economizer damper in this manner, first determine the damper voltage output for minimum or base ventilation. Base ventilation is the

ventilation required to remove contaminants during unoccupied periods. The following equation may be used to determine the percent of outside-air entering the building for a given damper position. For best results there should be at least a 10 degree difference in outside and return-air temperatures.

$$(T_O \times \frac{OA}{100}) + (T_R \times \frac{RA}{100}) = T_M$$

T<sub>O</sub> = Outdoor-Air Temperature  
 OA = Percent of Outdoor Air  
 T<sub>R</sub> = Return-Air Temperature  
 RA = Percent of Return Air  
 T<sub>M</sub> = Mixed-Air Temperature

Once base ventilation has been determined, set the minimum damper position potentiometer to the correct position.

The same equation can be used to determine the occupied or maximum ventilation rate to the building. For example, an output of 3.6 volts to the actuator provides a base ventilation rate of 5% and an output of 6.7 volts provides the maximum ventilation rate of 20% (or base plus 15 cfm per person). Use Fig. 42 to determine the maximum setting of the CO<sub>2</sub> sensor. For example, a 1100 ppm set point relates to a 15 cfm per person design. Use the 1100 ppm curve on Fig. 42 to find the point when the CO<sub>2</sub> sensor output will be 6.7 volts. Line up the point on the graph with the left side of the chart to determine that the range configuration for the CO<sub>2</sub> sensor should be 1800 ppm. The EconoMi\$erIV controller will output the 6.7 volts from the CO<sub>2</sub> sensor to the actuator when the CO<sub>2</sub> concentration in the space is at 1100 ppm. The DCV set point may be left at 2 volts since the CO<sub>2</sub> sensor voltage will be ignored by the EconoMi\$erIV controller until it rises above the 3.6 volt setting of the minimum position potentiometer.

Once the fully occupied damper position has been determined, set the maximum damper demand control ventilation potentiometer to this position. Do not set to the maximum position as this can result in over-ventilation to the space and potential high-humidity levels.

**CO<sub>2</sub> Sensor Configuration** — The CO<sub>2</sub> sensor has preset standard voltage settings that can be selected anytime after the sensor is powered up. See Table 13.

Use setting 1 or 2 for Carrier equipment. See Table 13.

1. Press Clear and Mode buttons. Hold at least 5 seconds until the sensor enters the Edit mode.
2. Press Mode twice. The STDSET Menu will appear.
3. Use the Up/Down button to select the preset number. See Table 13.
4. Press Enter to lock in the selection.
5. Press Mode to exit and resume normal operation.

The custom settings of the CO<sub>2</sub> sensor can be changed anytime after the sensor is energized. Follow the steps below to change the non-standard settings:

1. Press Clear and Mode buttons. Hold at least 5 seconds until the sensor enters the Edit mode.
2. Press Mode twice. The STDSET Menu will appear.
3. Use the Up/Down button to toggle to the NONSTD menu and press Enter.
4. Use the Up/Down button to toggle through each of the nine variables, starting with Altitude, until the desired setting is reached.
5. Press Mode to move through the variables.
6. Press Enter to lock in the selection, then press Mode to continue to the next variable.

**Table 13 — CO<sub>2</sub> Sensor Standard Settings**

SETTING	EQUIPMENT	OUTPUT	VENTILATION RATE (cfm/Person)	ANALOG OUTPUT	CO <sub>2</sub> CONTROL RANGE (ppm)	OPTIONAL RELAY SETPOINT (ppm)	RELAY HYSTERESIS (ppm)
1	Interface with Standard Building Control System	Proportional	Any	0-10V 4-20 mA	0-2000	1000	50
2		Proportional	Any	2-10V 7-20 mA	0-2000	1000	50
3		Exponential	Any	0-10V 4-20 mA	0-2000	1100	50
4	Economizer	Proportional	15	0-10V 4-20 mA	0-1100	1100	50
5		Proportional	20	0-10V 4-20 mA	0- 900	900	50
6		Exponential	15	0-10V 4-20 mA	0-1100	1100	50
7		Exponential	20	0-10V 4-20 mA	0- 900	900	50
8	Health & Safety	Proportional	—	0-10V 4-20 mA	0-9999	5000	500
9	Parking/Air Intakes/ Loading Docks	Proportional	—	0-10V 4-20 mA	0-2000	700	50

LEGEND

ppm — Parts Per Million

Dehumidification of Fresh Air with DCV Control — Information from ASHRAE indicates that the largest humidity load on any zone is the fresh air introduced. For some applications, a field-installed energy recovery unit can be added to reduce the moisture content of the fresh air being brought into the building when the enthalpy is high. In most cases, the normal heating and cooling processes are more than adequate to remove the humidity loads for most commercial applications.

If normal rooftop heating and cooling operation is not adequate for the outdoor humidity level, an energy recovery unit and/or a dehumidification option should be considered.

**Step 14 — Install Humidistat for Optional MoistureMi\$er™ Package** — MoistureMi\$er dehumidification package operation can be controlled by field installation of a Carrier-approved humidistat. To install the humidistat perform the following procedure:

1. Locate humidistat on a solid interior wall in the conditioned space. Location should be a well ventilated area to sense average humidity.
2. Route thermostat cable or equivalent single leads of colored wire from Humidistat terminals through conduit in unit to the low voltage connection on the 2-pole terminal strip (TB3) as shown in Fig. 43 and Fig. 44. See Fig. 45 for operational diagram.

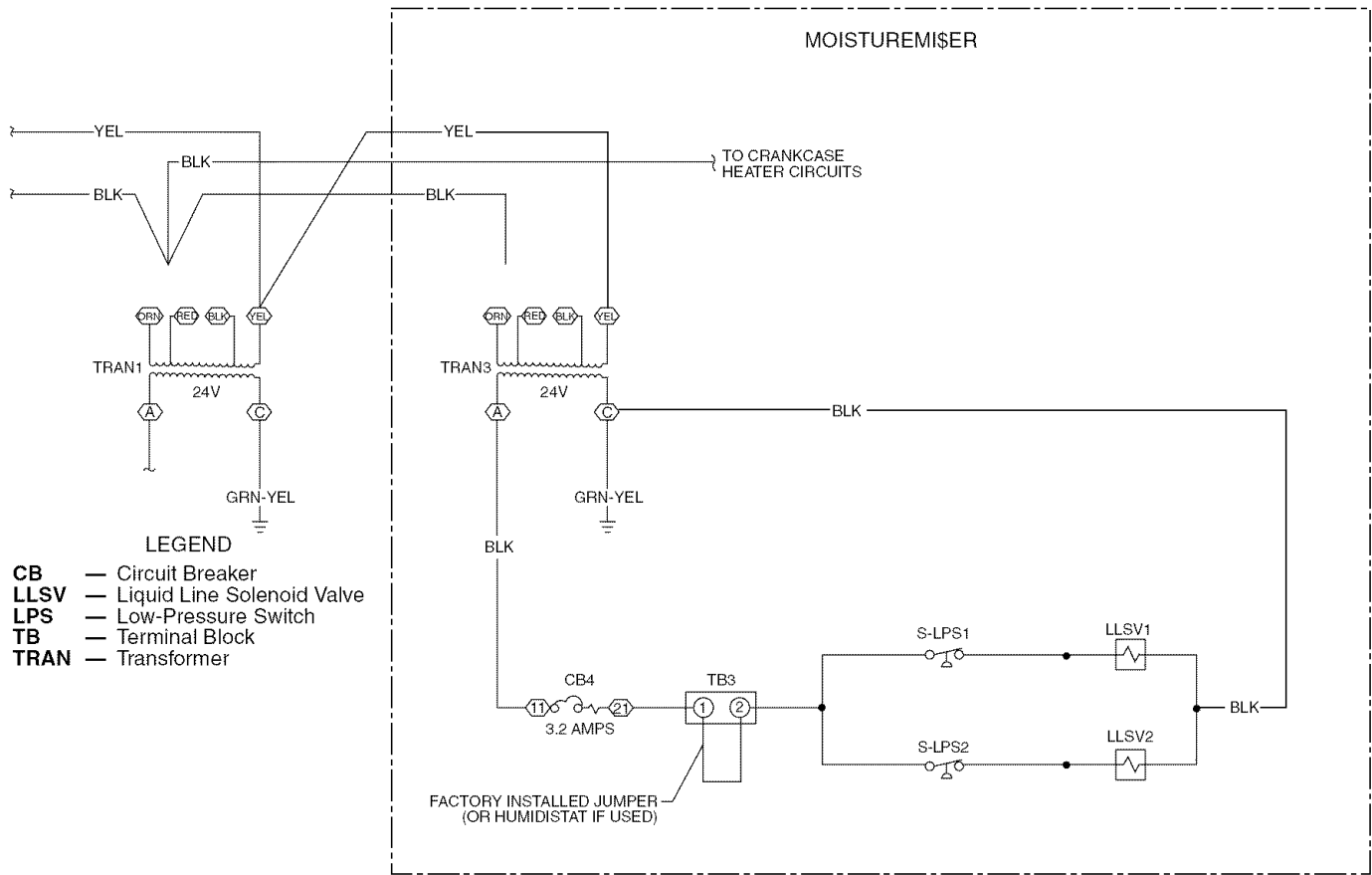

**Fig. 43 — Typical MoistureMiSer™ Dehumidification Package Humidistat Wiring Schematic (460 V Unit Shown)**

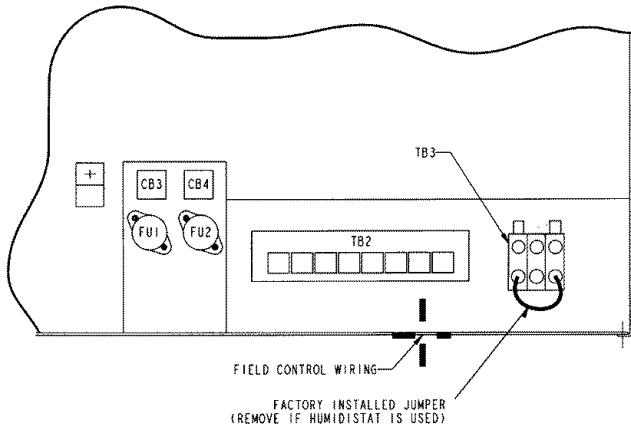

**Fig. 44 — Typical MoistureMiSer Dehumidification Package Control Box**

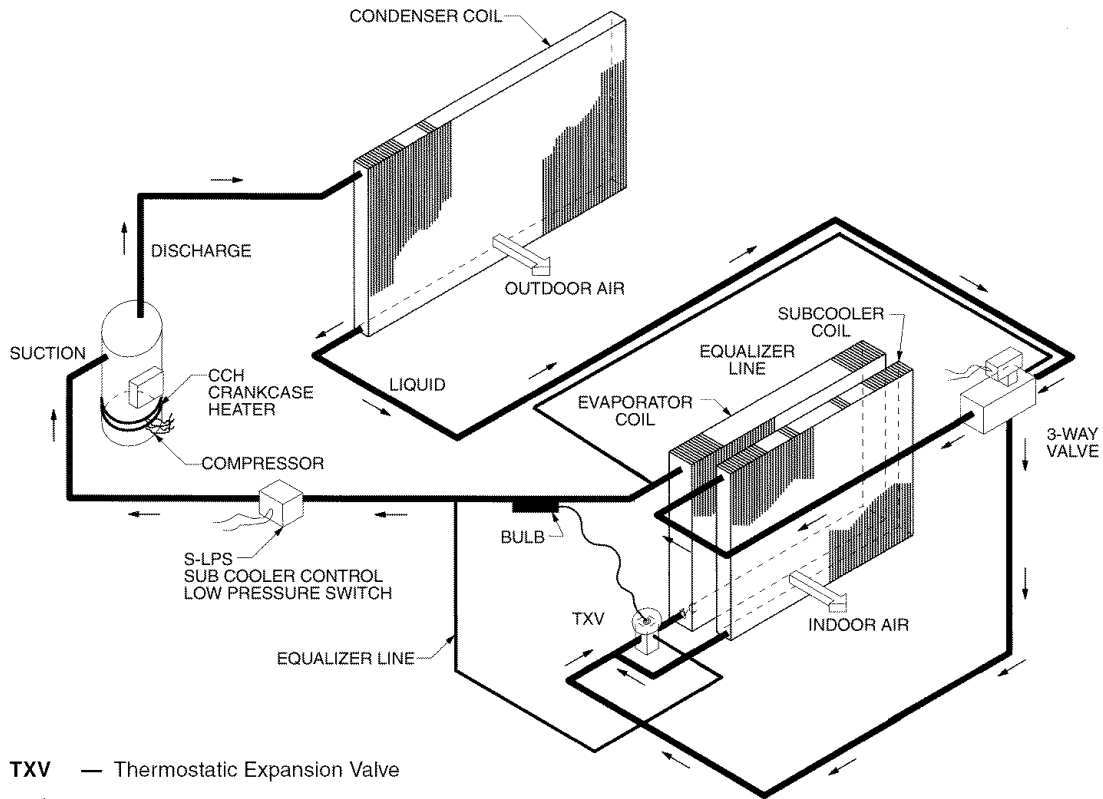

**Fig. 45 — MoistureMiSer™ Dehumidification Package Operation Diagram**

### START-UP

Use the following information and Start-Up Checklist on page CL-1 to check out unit PRIOR to start-up.

**Unit Preparation** — Check that unit has been installed in accordance with these installation instructions and all applicable codes.

**COMPRESSOR MOUNTING** — Do not loosen or remove compressor hold-down bolts.

**REFRIGERANT SERVICE PORTS** — Each refrigerant system has a total of 3 Schrader-type service ports. One port is located on the suction line, one on the compressor discharge line, and one on the liquid line. In addition Schrader-type valves are located underneath the low-pressure switches. Be sure that caps on the ports are tight.

#### COMPRESSOR ROTATION

**48TJ016 and 020 Only** — The unit is equipped with a Phase Monitor Relay (PMR) board located in the control box. The PMR device will not allow the unit to run if field power is connected incorrectly. To determine if the Phase Monitor Relay is preventing the unit from starting, check to see if the red LED is blinking. If the LED is blinking, the 3-phase field power has been wired incorrectly. A solid light means that field power connections are correct.

**48TJ024 and 028 Only** — It is important to be certain the compressors are rotating in the proper direction. To determine whether or not compressors are rotating in the proper direction:

1. Connect service gages to suction and discharge pressure fittings.
2. Energize the compressor.
3. The suction pressure should drop and the discharge pressure should rise, as is normal on any start-up.

If the suction pressure does not drop and the discharge pressure does not rise to normal levels:

1. Note that the evaporator fan is probably also rotating in the wrong direction.

2. Turn off power to the unit.
3. Reverse any two of the incoming power leads.
4. Turn on power to the unit.
5. Energize each compressor.

The suction and discharge pressure levels should now move to their normal start-up levels.

**NOTE:** When compressors are rotating in the wrong direction, the unit will have increased noise levels and will not provide heating and cooling.

After a few minutes of reverse operation, the scroll compressor internal overload protection will open, which will activate the unit's lockout and requires a manual reset. Reset is accomplished by turning the thermostat on and off.

**INTERNAL WIRING** — Check all electrical connections in unit control boxes; tighten as required.

**CRANKCASE HEATER (SIZE 028 AND UNITS WITH MOISTUREMISER™ DEHUMIDIFICATION PACKAGE ONLY)** — Crankcase heater(s) is energized as long as there is power to the unit and the compressor is not operating.

**IMPORTANT:** Unit power must be on for 24 hours prior to start-up. Otherwise, damage to the compressor may result.

**EVAPORATOR FAN** — Fan belt and variable pulleys are factory-installed. Remove tape from the fan pulley. See Tables 14-19 for fan performance data. Be sure that fans rotate in the proper direction. See Table 20 for air quantity limits. See Tables 21-23 for static pressure information for accessories and options. See Table 24 for fan rpm at motor pulley settings. See Tables 25 and 26 for evaporator-fan motor data and evaporator-fan motor efficiency. To alter fan performance, see Evaporator Fan Performance Adjustment section on page 40.

**NOTE:** A 3½-in. bolt and threaded plate are included in the installer's packet for 48TJ020-028 units. They can be added to the motor support channel below the motor mounting plate to aid in raising the fan motor.

**Table 14 — Fan Performance — 48TJD016 (Low Heat Units)**

AIRFLOW (cfm)	AVAILABLE EXTERNAL STATIC PRESSURE (in. wg)																	
	0.2			0.4			0.6			0.8			1.0			1.2		
	Rpm	Bhp	Watts	Rpm	Bhp	Watts	Rpm	Bhp	Watts	Rpm	Bhp	Watts	Rpm	Bhp	Watts	Rpm	Bhp	Watts
4500	809	1.53	1317	906	1.74	1502	994	1.96	1690	1078	2.18	1882	1156	2.41	2077	1230	2.64	2275
4800	850	1.76	1516	942	1.98	1706	1027	2.20	1899	1107	2.43	2094	1183	2.66	2293	1255	2.89	2495
5100	892	2.01	1733	979	2.24	1928	1061	2.46	2125	1138	2.70	2325	1211	2.93	2528	1281	3.17	2733
5400	934	2.28	1970	1017	2.52	2169	1096	2.75	2371	1170	2.99	2575	1241	3.22	2781	1309	3.47	2990
5700	976	2.58	2225	1058	2.82	2429	1132	3.06	2635	1204	3.30	2843	1272	3.54	3053	1338	3.79	3266
6000	1019	2.90	2500	1096	3.14	2709	1168	3.38	2919	1238	3.63	3131	1304	3.88	3345	1368	4.13	3562
6300	1063	3.24	2795	1136	3.49	3008	1206	3.74	3223	1273	3.99	3439	1337	4.24	3657	—	—	—
6600	1106	3.61	3111	1177	3.86	3329	1244	4.11	3547	1309	4.37	3767	—	—	—	—	—	—
6900	1150	4.00	3448	1218	4.26	3670	—	—	—	—	—	—	—	—	—	—	—	—
7200	—	—	—	—	—	—	—	—	—	—	—	—	—	—	—	—	—	—
7500	—	—	—	—	—	—	—	—	—	—	—	—	—	—	—	—	—	—

AIRFLOW (cfm)	AVAILABLE EXTERNAL STATIC PRESSURE (in. wg)														
	1.4			1.6			1.8			1.9			2.0		
	Rpm	Bhp	Watts	Rpm	Bhp	Watts	Rpm	Bhp	Watts	Rpm	Bhp	Watts	Rpm	Bhp	Watts
4500	1301	2.87	2477	1369	3.11	2683	1434	3.35	2891	1497	3.47	2997	1497	3.60	3103
4800	1324	3.13	2700	1390	3.37	2909	1454	3.62	3120	1515	3.74	3226	1515	3.87	3334
5100	1349	3.41	2942	1413	3.66	3153	1475	3.90	3367	1535	4.03	3475	1535	4.16	3584
5400	1374	3.71	3202	1437	3.96	3416	1498	4.21	3633	—	—	—	—	—	—
5700	1402	4.04	3481	1463	4.29	3699	—	—	—	—	—	—	—	—	—
6000	—	—	—	—	—	—	—	—	—	—	—	—	—	—	—
6300	—	—	—	—	—	—	—	—	—	—	—	—	—	—	—
6600	—	—	—	—	—	—	—	—	—	—	—	—	—	—	—
6900	—	—	—	—	—	—	—	—	—	—	—	—	—	—	—
7200	—	—	—	—	—	—	—	—	—	—	—	—	—	—	—
7500	—	—	—	—	—	—	—	—	—	—	—	—	—	—	—

**LEGEND**

- Bhp** — Brake Horsepower
- FIOF** — Factory-Installed Option
- Watts** — Input Watts to Motor

**NOTES:**

1. Standard low-medium static drive range is 891 to 1179 rpm (for 208/230 and 460-v units) or 1159 to 1429 rpm (for 575-v units). Alternate high-static drive range is 1227 to 1550 (for 208/230 and 460-v units). The alternate high-static drive is not available for 48TJ016 575-v units. Other rpms require a field-supplied drive.
2. Maximum continuous bhp is 4.25 (208/230 and 460 v) or 3.45 (575 v) and the maximum continuous watts are 3775 (208/230 and 460 v) or 3065 (575 v). Do not adjust motor rpm such that motor maximum bhp and/or watts is exceeded at the maximum operating cfm.

3. Static pressure losses (i.e., economizer) must be added to external static pressure before entering Fan Performance table.
4. Interpolation is permissible. Do not extrapolate.
5. Fan performance is based on wet coils, clean filters, and casing losses. See Tables 21-23 for accessory/FIOF static pressure information.
6. Extensive motor and drive testing on these units ensures that the full horsepower and watts range of the motor can be utilized with confidence. Using fan motors up to the watts or bhp rating shown will not result in nuisance tripping or premature motor failure. Unit warranty will not be affected.
7. Use of a field-supplied motor may affect wiring size. Contact your Carrier representative for details.

**Table 15 — Fan Performance — 48TJD020 and 024 (Low Heat Units)**

AIRFLOW (cfm)	AVAILABLE EXTERNAL STATIC PRESSURE (in. wg)																	
	0.2			0.4			0.6			0.8			1.0			1.2		
	Rpm	Bhp	Watts	Rpm	Bhp	Watts	Rpm	Bhp	Watts	Rpm	Bhp	Watts	Rpm	Bhp	Watts	Rpm	Bhp	Watts
5,500	755	2.27	1908	831	2.58	2171	901	2.91	2443	968	3.24	2723	1031	3.58	3009	1091	3.93	3302
6,000	810	2.72	2287	881	3.04	2556	947	3.37	2833	1010	3.71	3116	1070	4.05	3406	1127	4.40	3702
6,500	866	3.22	2710	932	3.55	2985	994	3.88	3266	1054	4.23	3554	1111	4.57	3847	1166	4.93	4146
7,000	923	3.78	3177	985	4.11	3458	1044	4.45	3744	1100	4.80	4036	1155	5.15	4333	1207	5.51	4635
7,500	980	4.39	3690	1038	4.73	3976	1094	5.07	4267	1148	5.43	4564	1200	5.78	4864	1250	6.15	5170
8,000	1038	5.06	4251	1093	5.40	4542	1146	5.75	4838	1197	6.11	5138	1246	6.47	5443	1294	6.84	5752
8,500	1096	5.78	4859	1148	6.13	5156	1198	6.49	5456	1247	6.85	5761	1294	7.22	6070	1340	7.59	6382
9,000	1154	6.56	5517	1204	6.92	5818	1251	7.28	6123	1298	7.65	6432	1343	8.02	6745	1388	8.40	7062
9,500	1213	7.40	6224	1260	7.77	6531	1306	8.13	6840	1350	8.51	7154	1394	8.88	7471	1436	9.26	7791
10,000	1272	8.30	6983	1317	8.67	7294	1360	9.05	7608	1403	9.43	7926	1445	9.81	8247	1486	10.19	8570

AIRFLOW (cfm)	AVAILABLE EXTERNAL STATIC PRESSURE (in. wg)														
	1.4			1.6			1.8			1.9			2.0		
	Rpm	Bhp	Watts	Rpm	Bhp	Watts	Rpm	Bhp	Watts	Rpm	Bhp	Watts	Rpm	Bhp	Watts
5,500	1149	4.28	3602	1204	4.65	3907	1258	5.02	4217	1284	5.20	4375	1309	5.39	4533
6,000	1183	4.76	4003	1236	5.13	4310	1288	5.50	4622	1313	5.68	4780	1337	5.87	4939
6,500	1219	5.29	4450	1270	5.66	4759	1320	6.03	5073	1344	6.22	5232	1368	6.41	5391
7,000	1258	5.88	4942	1307	6.25	5253	1355	6.62	5569	1378	6.81	5729	1402	7.00	5890
7,500	1299	6.52	5480	1346	6.89	5794	1392	7.27	6113	1415	7.46	6273	1437	7.65	6435
8,000	1341	7.21	6065	1387	7.59	6383	1432	7.97	6704	1453	8.16	6866	1475	8.36	7028
8,500	1385	7.97	6699	1429	8.35	7019	1472	8.73	7343	1493	8.93	7506	1514	9.12	7670
9,000	1431	8.78	7382	1473	9.15	7705	1515	9.55	8032	1535	9.75	8196	—	—	—
9,500	1478	9.65	8114	1519	10.04	8441	—	—	—	—	—	—	—	—	—
10,000	—	—	—	—	—	—	—	—	—	—	—	—	—	—	—

**LEGEND**

- Bhp** — Brake Horsepower
- FIOF** — Factory-Installed Option
- Watts** — Input Watts to Motor

**NOTES:**

1. Standard low-medium static drive range for the 020 size is 910 to 1095 rpm. Standard low-medium static drive range for the 024 size is 1002 to 1225 rpm. Alternate high-static drive range for the 020 size is 1069 to 1287. Alternate high-static drive range for the 024 size is 1193 to 1458 rpm. Other rpms require a field-supplied drive.
2. Maximum continuous bhp for the 020 size is 5.90. Maximum continuous bhp for the 024 size is 8.7 (208/230, 575 v) or 9.5 (460 v). The maximum continuous watts for the 020 size is 5180. The maximum continuous watts for the 024 size is 7915 (208/230, 575 v) or 8640 (460 v). Do not

- adjust motor rpm such that motor maximum bhp and/or watts is exceeded at the maximum operating cfm.
3. Static pressure losses (i.e., economizer) must be added to external static pressure before entering Fan Performance table.
4. Interpolation is permissible. Do not extrapolate.
5. Fan performance is based on wet coils, clean filters, and casing losses. See Tables 21-23 for accessory/FIOF static pressure information.
6. Extensive motor and drive testing on these units ensures that the full horsepower and watts range of the motor can be utilized with confidence. Using fan motors up to the watts or bhp rating shown will not result in nuisance tripping or premature motor failure. Unit warranty will not be affected.
7. Use of a field-supplied motor may affect wiring size. Contact your Carrier representative for details.



**Table 16 — Fan Performance — 48TJD028 (Low Heat Units)**

AIRFLOW (cfm)	AVAILABLE EXTERNAL STATIC PRESSURE (in. wg)																	
	0.2			0.4			0.6			0.8			1.0			1.2		
	Rpm	Bhp	Watts	Rpm	Bhp	Watts	Rpm	Bhp	Watts	Rpm	Bhp	Watts	Rpm	Bhp	Watts	Rpm	Bhp	Watts
7,000	941	3.35	2769	1002	3.80	3140	1061	4.27	3528	1117	4.76	3934	1171	5.27	4356	1224	5.80	4794
7,500	999	4.05	3348	1057	4.53	3742	1112	5.02	4152	1166	5.54	4579	1218	6.07	5020	1268	6.63	5478
8,000	1058	4.85	4007	1113	5.35	4424	1165	5.87	4856	1216	6.41	5304	1266	6.97	5766	1314	7.55	6243
8,500	1117	5.74	4750	1169	6.28	5190	1219	6.83	5645	1268	7.40	6114	1315	7.98	6597	1361	8.58	7094
9,000	1177	6.75	5583	1226	7.31	6047	1274	7.89	6524	1320	8.48	7015	1365	9.09	7520	1410	9.72	8037
9,500	1237	7.98	6511	1284	8.46	6999	1329	9.07	7499	1374	9.69	8012	1417	10.33	8538	1459	10.98	9076
10,000	1297	9.12	7450	1342	9.74	8051	1385	10.37	8574	1428	11.02	9110	1469	11.68	9657	1510	12.36	10217
10,500	1358	10.49	8674	1400	11.14	9209	1442	11.80	9755	1483	12.47	10314	1523	13.16	10883	—	—	—
11,000	1418	12.00	9919	1459	12.67	10478	—	—	—	—	—	—	—	—	—	—	—	—
11,250	1449	12.80	10585	—	—	—	—	—	—	—	—	—	—	—	—	—	—	—

AIRFLOW (cfm)	AVAILABLE EXTERNAL STATIC PRESSURE (in. wg)								
	1.4			1.6			1.8		
	Rpm	Bhp	Watts	Rpm	Bhp	Watts	Rpm	Bhp	Watts
7,000	1274	6.35	5248	1323	6.92	5718	1371	5.54	6204
7,500	1316	7.20	6960	1364	7.79	6437	1410	6.41	6939
8,000	1360	8.14	6734	1406	8.76	7239	1450	7.40	7759
8,500	1406	9.20	7605	1449	9.83	8129	1492	8.48	8666
9,000	1453	10.36	8568	1495	11.02	9111	1536	9.69	9667
9,500	1501	11.64	9627	1541	12.32	10190	—	—	—
10,000	—	—	—	—	—	—	—	—	—
10,500	—	—	—	—	—	—	—	—	—
11,000	—	—	—	—	—	—	—	—	—
11,250	—	—	—	—	—	—	—	—	—

**LEGEND**

- Bhp** — Brake Horsepower
- FIOF** — Factory-Installed Option
- Watts** — Input Watts to Motor

**NOTES:**

1. Standard low-medium static drive range is 1066 to 1283 rpm. Alternate high-static drive range is 1332 to 1550. Other rpms require a field-supplied drive.
2. Maximum continuous bhp is 10.2 (208/230, 575 v) or 11.8 (460 v) and the maximum continuous watts are 9510 (208/230, 575 v) or 11,000 (460 v). Do not adjust motor rpm such that motor maximum bhp and/or watts is exceeded at the maximum operating cfm.

3. Static pressure losses (i.e., economizer) must be added to external static pressure before entering Fan Performance table.
4. Interpolation is permissible. Do not extrapolate.
5. Fan performance is based on wet coils, clean filters, and casing losses. See Tables 21-23 for accessory/FIOF static pressure information.
6. Extensive motor and drive testing on these units ensures that the full horsepower and watts range of the motor can be utilized with confidence. Using fan motors up to the watts or bhp rating shown will not result in nuisance tripping or premature motor failure. Unit warranty will not be affected.
7. Use of a field-supplied motor may affect wiring size. Contact your Carrier representative for details.

**Table 17 — Fan Performance — 48TJF016 (High Heat Units)**

AIRFLOW (cfm)	AVAILABLE EXTERNAL STATIC PRESSURE (in. wg)																	
	0.2			0.4			0.6			0.8			1.0			1.2		
	Rpm	Bhp	Watts	Rpm	Bhp	Watts	Rpm	Bhp	Watts	Rpm	Bhp	Watts	Rpm	Bhp	Watts	Rpm	Bhp	Watts
4500	819	1.55	1335	914	1.76	1518	1001	1.98	1705	1083	2.20	1894	1160	2.42	2088	1234	2.65	2284
4800	861	1.78	1538	951	2.00	1726	1035	2.22	1916	1113	2.45	2110	1188	2.68	2307	1259	2.91	2507
5100	904	2.04	1759	989	2.26	1952	1069	2.49	2147	1145	2.72	2345	1218	2.95	2545	1287	3.17	2749
5400	947	2.32	1999	1028	2.55	2197	1105	2.78	2396	1179	3.01	2598	1248	3.25	2802	1315	3.49	3009
5700	990	2.62	2259	1068	2.85	2461	1142	3.09	2665	1213	3.33	2871	1280	3.57	3079	1345	3.81	3289
6000	1034	2.94	2539	1109	3.18	2745	1180	3.42	2953	1248	3.67	3163	1313	3.91	3375	1376	4.16	3589
6300	1078	3.29	2840	1150	3.54	3050	1218	3.78	3262	1284	4.03	3476	1348	4.28	3692	—	—	—
6600	1123	3.67	3161	1192	3.91	3376	1258	4.16	3592	—	—	—	—	—	—	—	—	—
6900	1167	4.06	3504	1234	4.32	3723	—	—	—	—	—	—	—	—	—	—	—	—
7200	—	—	—	—	—	—	—	—	—	—	—	—	—	—	—	—	—	—

AIRFLOW (cfm)	AVAILABLE EXTERNAL STATIC PRESSURE (in. wg)														
	1.4			1.6			1.8			1.9			2.0		
	Rpm	Bhp	Watts	Rpm	Bhp	Watts	Rpm	Bhp	Watts	Rpm	Bhp	Watts	Rpm	Bhp	Watts
4500	1304	2.88	2484	1371	3.12	2688	1435	3.36	2895	1467	3.48	2999	1497	3.60	3104
4800	1327	3.14	2711	1393	3.38	2917	1456	3.62	3126	1486	3.75	3232	1517	3.87	3338
5100	1353	3.43	2955	1417	3.67	3165	1478	3.92	3377	1508	4.04	3484	1537	4.16	3592
5400	1380	3.73	3219	1442	3.98	3432	1502	4.23	3646	1531	4.35	3755	—	—	—
5700	1408	4.06	3503	1468	4.31	3718	—	—	—	—	—	—	—	—	—
6000	—	—	—	—	—	—	—	—	—	—	—	—	—	—	—
6300	—	—	—	—	—	—	—	—	—	—	—	—	—	—	—
6600	—	—	—	—	—	—	—	—	—	—	—	—	—	—	—
6900	—	—	—	—	—	—	—	—	—	—	—	—	—	—	—
7200	—	—	—	—	—	—	—	—	—	—	—	—	—	—	—

**LEGEND**

- Bhp** — Brake Horsepower
- FIOF** — Factory-Installed Option
- Watts** — Input Watts to Motor

**NOTES:**

1. Standard low-medium static drive range is 891 to 1179 rpm (for 208/230 and 460-v units) or 1159 to 1429 rpm (for 575-v units). Alternate high-static drive range is 1227 to 1550 (for 208/230 and 460-v units). The alternate high-static drive is not available for 48TJ016 575-v units. Other rpms require a field-supplied drive.
2. Maximum continuous bhp is 4.25 (208/230 and 460 v) or 3.45 (575 v) and the maximum continuous watts are 3775 (208/230 and 460 v) or

- 3065 (575 v). Do not adjust motor rpm such that motor maximum bhp and/or watts is exceeded at the maximum operating cfm.
3. Static pressure losses (i.e., economizer) must be added to external static pressure before entering Fan Performance table.
4. Interpolation is permissible. Do not extrapolate.
5. Fan performance is based on wet coils, clean filters, and casing losses. See Tables 21-23 for accessory/FIOF static pressure information.
6. Extensive motor and drive testing on these units ensures that the full horsepower and watts range of the motor can be utilized with confidence. Using fan motors up to the watts or bhp rating shown will not result in nuisance tripping or premature motor failure. Unit warranty will not be affected.
7. Use of a field-supplied motor may affect wiring size. Contact your Carrier representative for details.

**Table 18 — Fan Performance — 48TJF020 and 024 (High Heat Units)**

AIRFLOW (cfm)	AVAILABLE EXTERNAL STATIC PRESSURE (in. wg)																	
	0.2			0.4			0.6			0.8			1.0			1.2		
	Rpm	Bhp	Watts	Rpm	Bhp	Watts	Rpm	Bhp	Watts	Rpm	Bhp	Watts	Rpm	Bhp	Watts	Rpm	Bhp	Watts
5,500	795	2.43	2043	866	2.74	2306	934	3.07	2578	998	3.40	2856	1059	3.74	3142	1117	4.08	3434
6,000	854	2.92	2452	921	3.24	2722	984	3.57	3998	1044	3.90	3281	1102	4.25	3570	1158	4.60	3865
6,500	914	3.46	2909	977	3.79	3184	1036	4.12	3465	1093	4.46	3752	1148	4.81	4045	1201	5.16	4343
7,000	975	4.06	3414	1034	4.39	3695	1090	4.73	3981	1144	5.08	4272	1196	5.43	4569	1246	5.79	4870
7,500	1037	4.72	3969	1092	5.06	4255	1145	5.41	4546	1196	5.76	4842	1256	6.12	5142	1294	6.48	5447
8,000	1099	5.44	4575	1150	5.79	4866	1201	6.14	5162	1249	6.50	5462	1297	6.86	5766	1343	7.22	6075
8,500	1161	6.22	5232	1210	6.57	5529	1258	6.93	5829	1304	7.29	6134	1349	7.66	6443	1393	8.03	6755
9,000	1223	7.07	5943	1270	7.43	6245	1315	7.79	6550	1360	8.16	6869	1403	8.53	7171	1445	8.90	7487
9,500	1286	7.98	6708	1331	8.34	7014	1374	8.71	7324	1416	9.08	7638	1457	9.46	7954	1498	9.84	8274
10,000	1349	8.95	7528	1392	9.32	7839	1433	9.70	8154	1473	10.07	8471	—	—	—	—	—	—

AIRFLOW (cfm)	AVAILABLE EXTERNAL STATIC PRESSURE (in. wg)														
	1.4			1.6			1.8			1.9			2.0		
	Rpm	Bhp	Watts	Rpm	Bhp	Watts	Rpm	Bhp	Watts	Rpm	Bhp	Watts	Rpm	Bhp	Watts
5,500	1173	4.44	3732	1227	4.80	4036	1279	5.17	4345	1304	5.35	4502	1329	5.54	4629
6,000	1211	4.95	4165	1263	5.32	4471	1313	5.69	4782	1337	5.87	4939	1361	6.06	5097
6,500	1252	5.53	4646	1302	5.89	4954	1350	6.26	5267	1373	6.56	5425	1396	6.84	5584
7,000	1295	6.16	5176	1343	6.52	5487	1389	6.90	5802	1412	7.09	5961	1434	7.28	6121
7,500	1340	6.85	5756	1386	7.22	6070	1431	7.60	6387	1452	7.79	6547	1474	7.98	6709
8,000	1388	7.60	6388	1431	7.97	6704	1474	8.35	7024	1495	8.54	7186	1516	8.74	7348
8,500	1436	8.41	7071	1478	8.79	7390	1520	9.17	7713	1540	9.37	7876	—	—	—
9,000	1486	9.28	7807	1527	9.67	8130	—	—	—	—	—	—	—	—	—
9,500	1538	10.22	8597	—	—	—	—	—	—	—	—	—	—	—	—
10,000	—	—	—	—	—	—	—	—	—	—	—	—	—	—	—

**LEGEND**

- Bhp** — Brake Horsepower
- FIOF** — Factory-Installed Option
- Watts** — Input Watts to Motor

**NOTES:**

1. Standard low-medium static drive range for the 020 size is 910 to 1095 rpm. Standard low-medium static drive range for the 024 size is 1002 to 1225 rpm. Alternate high-static drive range for the 020 size is 1069 to 1287. Alternate high-static drive range for the 024 size is 1193 to 1458 rpm. Other rpms require a field-supplied drive.
2. Maximum continuous bhp for the 020 size is 5.90. Maximum continuous bhp for the 024 size is 8.7 (208/230, 575 v) or 9.5 (460 v). The maximum continuous watts for the 020 size is 5180. The maximum continuous watts for the 024 size is 7915 (208/230, 575 v) or 8640 (460 v). Do not

- adjust motor rpm such that motor maximum bhp and/or watts is exceeded at the maximum operating cfm.
3. Static pressure losses (i.e., economizer) must be added to external static pressure before entering Fan Performance table.
4. Interpolation is permissible. Do not extrapolate.
5. Fan performance is based on wet coils, clean filters, and casing losses. See Tables 21-23 for accessory/FIOF static pressure information.
6. Extensive motor and drive testing on these units ensures that the full horsepower and watts range of the motor can be utilized with confidence. Using fan motors up to the watts or bhp rating shown will not result in nuisance tripping or premature motor failure. Unit warranty will not be affected.
7. Use of a field-supplied motor may affect wiring size. Contact your Carrier representative for details.

**Table 19 — Fan Performance — 48TJF028 (High Heat Units)**

AIRFLOW (cfm)	AVAILABLE EXTERNAL STATIC PRESSURE (in. wg)																	
	0.2			0.4			0.6			0.8			1.0			1.2		
	Rpm	Bhp	Watts	Rpm	Bhp	Watts	Rpm	Bhp	Watts	Rpm	Bhp	Watts	Rpm	Bhp	Watts	Rpm	Bhp	Watts
7,000	992	4.05	3,348	1051	4.44	3,668	1106	4.83	3995	1160	5.24	4331	1212	5.65	4675	1262	6.08	5026
7,500	1055	4.77	3,947	1110	5.17	4,277	1162	5.58	4615	1214	6.00	4960	1263	6.43	5312	1311	6.86	5672
8,000	1118	5.58	4,610	1170	5.99	4,950	1220	6.41	5298	1268	6.84	5653	1315	7.27	6014	1361	7.72	6382
8,500	1182	6.46	5,339	1231	6.88	5,690	1278	7.31	6047	1324	7.75	6411	1369	8.20	6782	1413	8.66	7158
9,000	1246	7.42	6,136	1292	7.86	6,498	1337	8.30	6865	1381	8.75	7239	1424	9.21	7618	1466	9.68	8003
9,500	1310	8.47	7,005	1354	8.92	7,377	1397	9.38	7754	1439	9.84	8137	1480	10.31	8525	1520	10.79	8918
10,000	1374	9.61	7,947	1416	10.07	8,329	1457	10.54	8715	1497	11.02	9107	1537	11.50	9504	—	—	—
10,500	1439	10.84	8,964	1479	11.32	9,356	1518	11.79	9752	—	—	—	—	—	—	—	—	—
11,000	1503	12.17	10,059	1542	12.65	10,460	—	—	—	—	—	—	—	—	—	—	—	—
11,250	1536	12.86	10,636	—	—	—	—	—	—	—	—	—	—	—	—	—	—	—

AIRFLOW (cfm)	AVAILABLE EXTERNAL STATIC PRESSURE (in. wg)								
	1.4			1.6			1.8		
	Rpm	Bhp	Watts	Rpm	Bhp	Watts	Rpm	Bhp	Watts
7,000	1311	6.51	5385	1359	6.96	5751	1405	6.00	6124
7,500	1358	7.30	6039	1403	7.76	6412	1448	6.84	6792
8,000	1406	8.17	6767	1560	8.63	7137	1492	7.75	7524
8,500	1456	9.12	7541	1498	9.59	7929	1539	8.75	8323
9,000	1507	10.15	8393	1548	10.63	8790	—	—	—
9,500	—	—	—	—	—	—	—	—	—
10,000	—	—	—	—	—	—	—	—	—
10,500	—	—	—	—	—	—	—	—	—
11,000	—	—	—	—	—	—	—	—	—
11,250	—	—	—	—	—	—	—	—	—

**LEGEND**

- Bhp** — Brake Horsepower
- FIOF** — Factory-Installed Option
- Watts** — Input Watts to Motor

**NOTES:**

1. Standard low-medium static drive range is 1066 to 1283 rpm. Alternate high-static drive range is 1332 to 1550. Other rpms require a field-supplied drive.
2. Maximum continuous bhp is 10.2 (208/230, 575 v) or 11.8 (460 v) and the maximum continuous watts are 9510 (208/230, 575 v) or 11,000 (460 v). Do not adjust motor rpm such that motor maximum bhp and/or watts is exceeded at the maximum operating cfm.

3. Static pressure losses (i.e., economizer) must be added to external static pressure before entering Fan Performance table.
4. Interpolation is permissible. Do not extrapolate.
5. Fan performance is based on wet coils, clean filters, and casing losses. See Tables 21-23 for accessory/FIOF static pressure information.
6. Extensive motor and drive testing on these units ensures that the full horsepower and watts range of the motor can be utilized with confidence. Using fan motors up to the watts or bhp rating shown will not result in nuisance tripping or premature motor failure. Unit warranty will not be affected.
7. Use of a field-supplied motor may affect wiring size. Contact your Carrier representative for details.

**Table 20 — Air Quantity Limits**

UNIT 48TJ	MINIMUM COOLING CFM	MINIMUM HEATING CFM		MAXIMUM CFM
		Low Heat	High Heat	
016	4500	3800	3800	7,500
020	5400	4750	5450	9,000
024	6000	4750	5450	10,000
028	7000	4750	5450	11,250

**Table 21 — Accessory/FIOP Static Pressure\*  
(in. wg) — 48TJ016**

COMPONENT	CFM				
	4500	5000	6000	7200	7500
Economizer	0.04	0.05	0.07	0.09	0.10

LEGEND

FIOP — Factory-Installed Option

\*The static pressure must be added to external static pressure. The sum and the evaporator entering-air cfm should then be used in conjunction with the Fan Performance tables to determine blower rpm and watts.

**Table 22 — Accessory/FIOP Static Pressure\*  
(in. wg) — 48TJ020-028**

COMPONENT	CFM					
	5000	6000	7200	9000	10,000	11,250
Economizer	0.06	0.07	0.09	0.11	0.12	0.14

LEGEND

FIOP — Factory-Installed Option

\*The static pressure must be added to external static pressure. The sum and the evaporator entering-air cfm should then be used in conjunction with the Fan Performance tables to determine blower rpm and watts.

**Table 23 — MoistureMiSer™ Dehumidification  
Package Static Pressure Drop (in. wg)**

UNIT SIZE	UNIT NOMINAL TONS	CFM PER TON		
		300	400	500
48TJ016	15	.040	.071	.111
48TJ020	18	.058	.102	.160
48TJ024	20	.071	.126	.197
48TJ028	25	.111	.197	.308

**Table 24 — Fan Rpm at Motor Pulley Settings\***

UNIT 48TJ	MOTOR PULLEY TURNS OPEN												
	0	1/2	1	1 1/2	2	2 1/2	3	3 1/2	4	4 1/2	5	5 1/2	6
016 (208/230, 460 v)†	††	††	1179	1150	1121	1093	1064	1035	1006	978	949	920	891
016 (208/230, 460 v)**	††	††	1559	1522	1488	1455	1422	1389	1356	1323	1289	1256	1227
016 (575 v)†	††	††	1429	1403	1376	1349	1323	1296	1269	1242	1215	1188	1159
020†	††	††	1095	1077	1058	1040	1021	1002	984	965	947	928	910
020**	††	††	1287	1265	1243	1222	1200	1178	1156	1134	1112	1091	1069
024†	††	††	1225	1209	1187	1165	1143	1120	1098	1076	1053	1031	1002
024**	††	††	1458	1434	1407	1381	1354	1328	1301	1275	1248	1222	1193
028†	††	††	1283	1269	1247	1225	1203	1182	1160	1138	1116	1095	1066
028**	††	††	††	††	1551	1524	1497	1470	1443	1415	1388	1361	1332

\*Approximate fan rpm shown.

†Indicates standard drive package.

\*\*Indicates alternate drive package.

††Due to belt and pulley size, pulley cannot be set to this number of turns open.

NOTE: For speeds not listed above, field-supplied drives are required.

**Table 25 — Evaporator-Fan Motor Data**

UNIT 48TJ	UNIT VOLTAGE	MAXIMUM ACCEPTABLE CONTINUOUS BHP*	MAXIMUM ACCEPTABLE CONTINUOUS BkW*	MAXIMUM ACCEPTABLE OPERATING WATTS	MAXIMUM AMP DRAW
016	208/230	4.25	3.17	3,775	10.5
	460	4.25	3.17	3,775	4.8
	575	3.45	2.59	3,065	3.9
020	208/230	5.90	4.40	5,180	15.8
	460				7.9
	575				6.0
024	208/230	8.70	6.49	7,915	22.0
	460	9.50	7.08	8,640	13.0
	575	8.70	6.49	7,915	10.0
028	208/230	10.20	7.61	9,510	28.0
	460	11.80	8.80	11,000	14.6
	575	10.20	7.61	9,510	13.0

LEGEND

**BHP** — Brake Horsepower  
**BkW** — Brake Kilowatts

\*Extensive motor and electrical testing on these units ensures that the full horsepower (brake kilowatt) range of the motors can be utilized with confidence. Using your fan motors up to the horsepower (brake kilowatt) ratings shown in this table will not result in nuisance tripping or premature motor failure. Unit warranty will not be affected.

NOTE: All indoor-fan motors 5 hp and larger meet the minimum efficiency requirements as established by the Energy Policy Act of 1992 (EPACT) effective October 24, 1997.

**Table 26 — Evaporator-Fan Motor Efficiency**

UNIT 48TJ	MOTOR EFFICIENCY (%)
016 (3.0 Hp)	81.7
016 (3.7 Hp)	85.8
020 (5 Hp)	87.5
024 (7.5 Hp)	88.5
028 (10 Hp)	89.5

NOTE: All indoor-fan motors 5 hp and larger meet the minimum efficiency requirements as established by the Energy Policy Act of 1992 (EPACT) effective October 24, 1997.

**CONDENSER-FANS AND MOTORS** — Condenser fans and motors are factory set. Refer to Condenser-Fan Adjustment section (page 42) as required. Be sure that fans rotate in the proper direction.

**RETURN-AIR FILTERS** — Check that correct filters are installed in filter tracks (see Table 1). Do not operate unit without return-air filters.

**OUTDOOR-AIR INLET SCREENS** — Outdoor-air inlet screens must be in place before operating unit.

**GAS HEAT** — Verify gas pressures before turning on heat as follows:

1. Turn off manual gas stop.
2. Connect pressure gage to supply gas pressure tap (see Fig. 13).
3. Connect pressure gage to manifold pressure tap on gas valve.
4. Turn on manual gas stop and set thermostat to HEAT position. Adjust set point to several degrees above the current room temperature to ensure a heat demand. After the unit has run for several minutes, verify that incoming pressure is 5.5 in. wg or greater, and that the manifold pressure is 3.3 in. wg. If manifold pressure must be adjusted, refer to Gas Valve Adjustment section on page 43.
5. After unit has been in operation for 5 minutes, check temperature rise across the heat exchangers. See unit informative plate for correct rise limits of the heat supplied. Air quantities may need to be adjusted to bring the actual rise to within the allowable limits.

**Operating Sequence**

**COOLING, UNITS WITHOUT ECONOMIZER** — When thermostat calls for cooling, terminals G and Y1 are energized. The indoor (evaporator) fan contactor (IFC), compressor contactor no. 1 (C1) and outdoor-fan contactor (OFC) are energized, and evaporator-fan motor, compressor no. 1, and both condenser fans start. The condenser-fan motors run continuously while unit is cooling. If the thermostat calls for a second stage of cooling by energizing Y2, compressor contactor no. 2 (C2) is energized and compressor no. 2 starts.

When the thermostat is satisfied, C1 and C2 are deenergized and the compressors and outdoor (condenser) fan motors (OFM) shut off. After a 30-second delay, the indoor (evaporator) fan motor (IFM) shuts off. If the thermostat fan selector switch is in the ON position, the evaporator-fan motor will run continuously.

**HEATING, UNITS WITHOUT ECONOMIZER** — When the thermostat calls for heating, terminal W1 is energized. In order to prevent thermostat short-cycling, the unit is locked into the Heating mode for at least 1 minute when W1 is energized. The induced-draft motor (IDM) is then energized and the burner ignition sequence begins. The indoor (evaporator) fan motor (IFM) is energized 45 seconds after a flame is ignited. On units equipped for two stages of heat, when additional heat is needed, W2 is energized and the high-fire solenoid on the main gas valve (MGV) is energized. When the thermostat is satisfied and W1 and W2 are deenergized, the IFM stops after a 45-second time-off delay.

**COOLING, UNITS WITH ECONOMIZER** — When free cooling is not available, the compressors will be controlled by the zone thermostat. When free cooling is available, the outdoor-air damper is modulated by the EconoMi\$erIV control to provide a 50 to 55 F supply-air temperature into the zone. As the supply-air temperature fluctuates above 55 or below 50 F, the dampers will be modulated (open or close) to bring the supply-air temperature back within the set point limits.

For EconoMi\$erIV operation, there must be a thermostat call for the fan (G). This will move the damper to its minimum position during the occupied mode.

Above 50 F supply-air temperature, the dampers will modulate from 100% open to the minimum open position. From 50 F to 45 F supply-air temperature, the dampers will maintain at the minimum open position. Below 45 F the dampers will be completely shut. As the supply-air temperature rises, the dampers will come back open to the minimum open position once the supply-air temperature rises to 48 F.

If optional power exhaust is installed, as the outdoor-air damper opens and closes, the power exhaust fan will be energized and deenergized.

If field-installed accessory CO<sub>2</sub> sensors are connected to the EconoMi\$erIV control, a demand controlled ventilation strategy will begin to operate. As the CO<sub>2</sub> level in the zone increases above the CO<sub>2</sub> set point, the minimum position of the damper will be increased proportionally. As the CO<sub>2</sub> level decreases because of the increase in fresh air, the outdoor-air damper will be proportionally closed. Damper position will follow the higher demand condition from DCV mode or free cooling mode.

Damper movement from full closed to full open (or vice versa) will take between 1½ and 2½ minutes.

If free cooling can be used as determined from the appropriate changeover command (switch, dry bulb, enthalpy curve, differential dry bulb, or differential enthalpy), a call for cooling (Y1 closes at the thermostat) will cause the control to modulate the dampers open to maintain the supply air temperature set point at 50 to 55 F.

As the supply-air temperature drops below the set point range of 50 to 55 F, the control will modulate the outdoor-air dampers closed to maintain the proper supply-air temperature.

**HEATING, UNITS WITH ECONOMI\$ERIV** — When the room thermostat calls for heat, the heating controls are energized as described in the Heating, Units Without Economizer section. When the indoor fan is energized, the economizer damper moves to the minimum position. When the indoor fan is off, the economizer damper is fully closed.

**COOLING, UNITS WITH ECONOMI\$ER2, PREMIER-LINK™ CONTROL AND A THERMOSTAT** — When free cooling is not available, the compressors will be controlled by the PremierLink control in response to the Y1 and Y2 inputs from the thermostat.

The PremierLink control will use the following information to determine if free cooling is available:

- Indoor fan has been on for at least 30 seconds.
- The SPT, SAT, and OAT inputs must have valid readings.
- OAT must be less than 75 F.
- OAT must be less than SPT.
- Enthalpy must be LOW (may be jumpered if an enthalpy sensor not available).
- Economizer position is NOT forced.

Pre-cooling occurs when there is no call from the thermostat except G. Pre-cooling is defined as the economizer modulates to provide 70 F supply air.

When free cooling is available the PremierLink control will control the compressors and economizer to provide a supply-air temperature determined to meet the Y1 and Y2 calls from the thermostat using the following three routines. The three control routines are based on OAT.

The 3 routines are based on OAT where:

SASP = Supply Air Set Point

DXCTLO = Direct Expansion Cooling Lockout Set Point

PID = Proportional Integral

**Routine 1 (OAT < DXCTLO)**

- Y1 energized – economizer maintains a SASP = (SATLO1 + 3).
- Y2 energized – economizer maintains a SASP = (SATLO2 + 3).

**Routine 2 (DXCTLO < OAT < 68 F)**

- If only Y1 energized, the economizer maintains a SASP = (SATLO1 + 3).
- If SAT > SASP + 5 and economizer position > 80%, economizer will go to minimum position for 3 minutes or until SAT > 68 F.
- First stage of mechanical cooling will be energized.
- Integrator resets.
- Economizer opens again and controls to current SASP after stage one on for 90 seconds.
- With Y1 and Y2 energized economizer maintains an SASP = SATLO2 + 3.
- If SAT > SASP + 5 and economizer position > 80%, economizer will go to minimum position for 3 minutes or until SAT > 68 F.
- If compressor one is on then second stage of mechanical cooling will be energized. Otherwise the first stage will be energized.
- Integrator resets.
- Economizer opens again and controls to SASP after stage one on for 90 seconds.

**Routine 3 (OAT > 68)**

- Economizer is opened 100%.
- Compressors 1 and 2 are cycled based on Y1 and Y2 using minimum on and off times and watching the supply air temperature as compared to SATLO1 and SATLO2 set points.

If optional power exhaust is installed, as the outdoor-air damper opens and closes, the power exhaust fans will be energized and deenergized.

If field-installed accessory CO<sub>2</sub> sensors are connected to the PremierLink control, a PID-controlled demand ventilation strategy will begin to operate. As the CO<sub>2</sub> level in the zone increases above the CO<sub>2</sub> set point, the minimum position of the damper will be increased proportionally. As the CO<sub>2</sub> level decreases because of the increase in fresh air, the outdoor-air damper will be proportionally closed.

**HEATING, UNITS WITH ECONOMI\$ER2, PREMIERLINK CONTROL AND A THERMOSTAT** — When the thermostat calls for heating, terminal W1 is energized. The PremierLink control will move the economizer damper to the minimum position if there is a call for G and closed if there is a call for W1 without G. In order to prevent thermostat from short cycling, the unit is locked into the heating mode for at least 10 minutes when W1 is energized. The induced-draft motor is then energized and the burner ignition sequence begins.

On units equipped for two stages of heat, when additional heat is needed, W2 is energized and the high-fire solenoid on the main gas valve (MGV) is energized. When the thermostat is satisfied and W1 is deenergized, the IFM stops after a 45-second time-off delay unless G is still maintained.

**COOLING, UNITS WITH ECONOMI\$ER2, PREMIER-LINK CONTROL AND A ROOM SENSOR** — When free cooling is not available, the compressors will be controlled by the PremierLink controller using a PID Error reduction calculation as indicated by Fig. 46.

The PremierLink controller will use the following information to determine if free cooling is available:

- Indoor fan has been on for at least 30 seconds.
- The SPT, SAT, and OAT inputs must have valid readings.
- OAT must be less than 75 F.
- OAT must be less than SPT.
- Enthalpy must be LOW (may be jumpered if and enthalpy sensor is not available).
- Economizer position is NOT forced.

When free cooling is available, the outdoor-air damper is positioned through the use of a Proportional Integral (PID) control process to provide a calculated supply-air temperature

into the zone. The supply air will maintain the space temperature between the heating and cooling set points as indicated in Fig. 47.

The PremierLink™ will integrate the compressors stages with the economizer based on similar logic as the three routines listed in the previous section. The SASP will float up and down based on the error reduction calculations that compare space temperature and space set point.

When outdoor-air temperature conditions require the economizer to close for a compressor stage-up sequence, the economizer control integrator is reset to zero after the stage-up sequence is completed. This prevents the supply-air temperature from dropping too quickly and creating a freeze condition that would make the compressor turn off prematurely.

The high space set point is used for DX (direct expansion) cooling control, while the economizer space set point is a calculated value between the heating and cooling set points. The economizer set point will always be at least one degree below the cooling set point, allowing for a smooth transition from mechanical cooling with economizer assist, back to economizer cooling as the cooling set point is achieved. The compressors may be used for initial cooling then the PremierLink controller will modulate the economizer using an error reduction calculation to hold the space temperature between the heating and cooling set points. See Fig. 47.

The controller uses the following conditions to determine economizer cooling:

- Enthalpy is Low
- SAT reading is available
- OAT reading is available
- SPT reading is available
- OAT ≤ SPT
- Economizer Position is NOT forced

If any of the above conditions are **not** met, the economizer submaster reference (ECSR) is set to maximum limit and the damper moves to minimum position. The operating sequence is complete. The ECSR is recalculated every 30 seconds.

If an optional power exhaust is installed, as the outdoor-air damper opens and closes, the power exhaust fans will be energized and deenergized.

If field-installed accessory CO<sub>2</sub> sensors are connected to the PremierLink control, a PID-controlled demand ventilation strategy will begin to operate. As the CO<sub>2</sub> level in the zone increases above the CO<sub>2</sub> set point, the minimum position of the damper will be increased proportionally. As the CO<sub>2</sub> level decreases because of the increase in fresh air, the outdoor-air damper will be proportionally closed.

**HEATING, UNIT WITH ECONOMISER2, PREMIERLINK CONTROL AND A ROOM SENSOR** — Every 40 seconds the controller will calculate the required heat stages (maximum of 3) to maintain supply air temperature (SAT) if the following qualifying conditions are met:

- Indoor fan has been on for at least 30 seconds.
- COOL mode is not active.
- OCCUPIED, TEMP.COMPENSATED START or HEAT mode is active.
- SAT reading is available.
- Fire shutdown mode is not active.

If all of the above conditions are met, the number of heat stages is calculated; otherwise the required number of heat stages will be set to 0.

If the PremierLink controller determines that heat stages are required, the economizer damper will be moved to minimum position if occupied and closed if unoccupied.

Staging should be as follows:

If Heating PID STAGES=2

- HEAT STAGES=1 (75% capacity) will energize HS1
- HEAT STAGES=2 (100% capacity) will energize HS2

In order to prevent short cycling, the unit is locked into the Heating mode for at least 10 minutes when HS1 is deenergized. When HS1 is energized the induced-draft motor is then energized and the burner ignition sequence begins. On units equipped for two stages of heat, when additional heat is needed, HS2 is energized and the high-fire solenoid on the main gas valve (MGV) is energized. When the space condition is satisfied and HS1 is deenergized the IFM stops after a 45-second time-off delay unless in the occupied mode. The fan will run continuously in the occupied mode as required by national energy and fresh air standards.

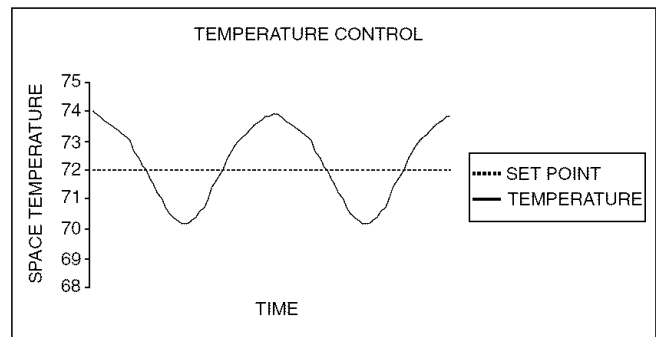

NOTE: PremierLink control performs smart staging of 2 stages of DX cooling and up to 3 stages of heat.

**Fig. 46 — DX Cooling Temperature Control Example**

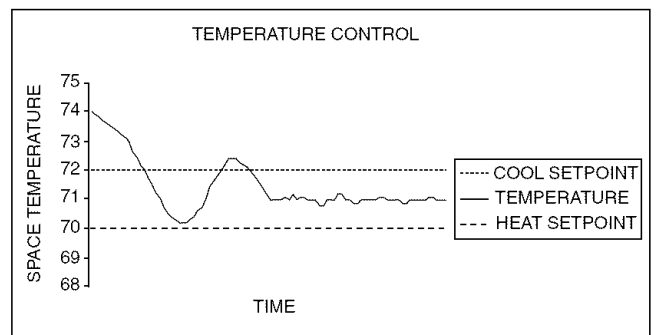

**Fig. 47 — Economizer Temperature Control Example**

## SERVICE

### ▲ WARNING

Before performing service or maintenance operations on unit, turn off main power switch to unit and install lockout tag on disconnect switch. Electrical shock could cause personal injury.

**Cleaning** — Inspect unit interior at beginning of each heating and cooling season and as operating conditions require (see Fig. 48). Remove unit top panel and/or side panels for access to unit interior.

**COIL MAINTENANCE AND CLEANING RECOMMENDATION** — Routine cleaning of coil surfaces is essential to maintain proper operation of the unit. Elimination of contamination and removal of harmful residues will greatly increase the life of the coil and extend the life of the unit. The following maintenance and cleaning procedures are recommended as part of the routine maintenance activities to extend the life of the coil.

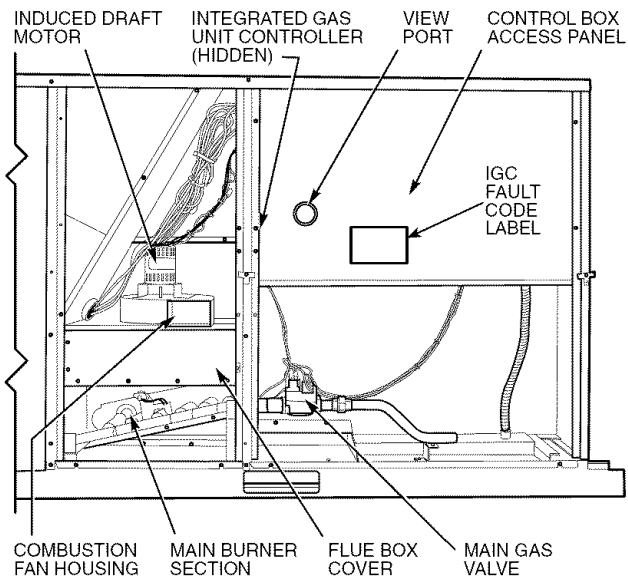

**Fig. 48 — Typical Gas Heating Section**

**Remove Surface Loaded Fibers** — Surface loaded fibers or dirt should be removed with a vacuum cleaner. If a vacuum cleaner is not available, a soft non-metallic bristle brush may be used. In either case, the tool should be applied in the direction of the fins. Coil surfaces can be easily damaged (fin edges can be easily bent over and damage to the coating of a protected coil) if the tool is applied across the fins.

**NOTE:** Use of a water stream, such as a garden hose, against a surface loaded coil will drive the fibers and dirt into the coil. This will make cleaning efforts more difficult. Surface loaded fibers must be completely removed prior to using low velocity clean water rinse.

**Periodic Clean Water Rinse** — A periodic clean water rinse is very beneficial for coils that are applied in coastal or industrial environments. However, it is very important that the water rinse is made with very low velocity water stream to avoid damaging the fin edges. Monthly cleaning as described below is recommended.

**Routine Cleaning of Coil Surfaces** — Monthly cleaning with Totaline® environmentally sound coil cleaner is essential to extend the life of coils. This cleaner is available from Carrier Replacement parts division as part number P902-0301 for a one gallon container, and part number P902-0305 for a 5 gallon container. It is recommended that all coils, including standard

aluminum, pre-coated, copper/copper or E-coated coils be cleaned with the Totaline environmentally sound coil cleaner as described below. Coil cleaning should be part of the unit's regularly scheduled maintenance procedures to ensure long life of the coil. Failure to clean the coils may result in reduced durability in the environment.

Avoid the use of:

- Coil brighteners
- Acid cleaning prior to painting
- High pressure washers
- Poor quality water for cleaning

Totaline environmentally sound coil cleaner is non-flammable, hypoallergenic, nonbacterial, and a USDA accepted biodegradable agent that will not harm the coil or surrounding components such as electrical wiring, painted metal surfaces, or insulation. Use of non-recommended coil cleaners is strongly discouraged since coil and unit durability could be affected.

*Totaline Environmentally Sound Coil Cleaner Application Equipment*

- 2½ gallon garden sprayer
- Water rinse with low velocity spray nozzle

### ▲ CAUTION

Harsh chemicals, household bleach or acid or basic cleaners should not be used to clean outdoor or indoor coils of any kind. These cleaners can be very difficult to rinse out of the coil and can accelerate corrosion at the fin/tube interface where dissimilar materials are in contact. If there is dirt below the surface of the coil, use the Totaline environmentally sound coil cleaner as described above.

### ▲ CAUTION

High velocity water from a pressure washer, garden hose, or compressed air should never be used to clean a coil. The force of the water or air jet will bend the fin edges and increase airside pressure drop. Reduced unit performance or nuisance unit shutdown may occur.

*Totaline Environmentally Sound Coil Cleaner Application Instructions*

1. Proper eye protection such as safety glasses is recommended during mixing and application.
2. Remove all surface loaded fibers and dirt with a vacuum cleaner as described above.
3. Thoroughly wet finned surfaces with clean water and a low velocity garden hose, being careful not to bend fins.
4. Mix Totaline environmentally sound coil cleaner in a 2½ gallon garden sprayer according to the instructions included with the cleaner. The optimum solution temperature is 100 F.

**NOTE:** Do **NOT USE** water in excess of 130 F, as the enzymatic activity will be destroyed.

5. Thoroughly apply Totaline environmentally sound coil cleaner solution to all coil surfaces including finned area, tube sheets and coil headers.
6. Hold garden sprayer nozzle close to finned areas and apply cleaner with a vertical, up-and-down motion. Avoid spraying in horizontal pattern to minimize potential for fin damage.
7. Ensure cleaner thoroughly penetrates deep into finned areas.
8. Interior and exterior finned areas must be thoroughly cleaned.
9. Finned surfaces should remain wet with cleaning solution for 10 minutes.

10. Ensure surfaces are not allowed to dry before rinsing. Reapplying cleaner as needed to ensure 10-minute saturation is achieved.
11. Thoroughly rinse all surfaces with low velocity clean water using downward rinsing motion of water spray nozzle. Protect fins from damage from the spray nozzle.

**CONDENSATE DRAIN** — Check and clean each year at start of cooling season. In winter, keep drains and traps dry.

During periods of low outdoor temperatures, add anti-freeze solution to the drain to prevent freeze up. Follow all precautions on anti-freeze labeling.

**FILTERS** — Clean or replace at start of each heating and cooling season, or more often if operating conditions require. Refer to Table 1 for type and size.

**OUTDOOR-AIR INLET SCREENS** — Clean screens with steam or hot water and a mild detergent. Do not use throwaway filters in place of screens. See Table 1 for quantity and size.

**MAIN BURNER** — At the beginning of each heating season, inspect for deterioration or blockage due to corrosion or other causes. Observe the main burner flames. Refer to Main Burners section on 43.

**FLUE GAS PASSAGEWAYS** — The flue collector box and heat exchanger cells may be inspected by removing heat exchanger access panel (see Fig. 4 and 5), flue box cover, and main burner assembly. Refer to Main Burners section on page 43 for burner removal sequence. If cleaning is required, remove heat exchanger baffles and clean tubes with a wire brush.

Use caution with ceramic heat exchanger baffles. When installing retaining clip, be sure the center leg of the clip extends inward toward baffle. See Fig. 49.

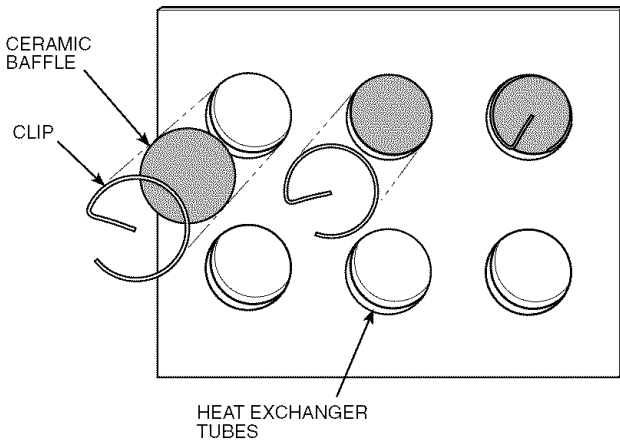

NOTE: One baffle and clip will be in each upper tube of the heat exchanger.

**Fig. 49 — Removing Heat Exchanger Ceramic Baffles and Clips**

**COMBUSTION-AIR BLOWER** — Clean periodically to assure proper airflow and heating efficiency. Inspect blower wheel every fall and periodically during heating season. For the first heating season, inspect blower wheel bi-monthly to determine proper cleaning frequency.

To inspect blower wheel, remove heat exchanger access panel. Shine a flashlight into opening to inspect wheel. If cleaning is required, remove motor and wheel assembly by removing screws holding motor mounting plate to top of combustion fan housing. The motor and wheel assembly will slide up and out of the fan housing. Remove the blower wheel from the motor shaft and clean with a detergent or solvent. Replace motor and wheel assembly.

## Lubrication

**COMPRESSORS** — Each compressor is charged with the correct amount of oil at the factory. Conventional white oil (Sontext 200LT) is used. White oil is compatible with 3GS oil, and 3GS oil may be used if the addition of oil is required. See compressor nameplate for original oil charge. A complete re-charge should be four ounces less than the original oil charge. When a compressor is exchanged in the field it is possible that a major portion of the oil from the replaced compressor may still be in the system. While this will not affect the reliability of the replacement compressor, the extra oil will add rotor drag and increase power usage. To remove this excess oil, an access valve may be added to the lower portion of the suction line at the inlet of the compressor. The compressor should then be run for 10 minutes, shut down, and the access valve opened until no oil flows. This should be repeated twice to make sure the proper oil level has been achieved.

**FAN SHAFT BEARINGS** — For size 016 units, bearings are permanently lubricated. No field lubrication is required. For size 020-028 units, lubricate bearings at least every 6 months with suitable bearing grease. Extended grease line is provided for far side fan bearing (opposite drive side). Typical lubricants are given below:

MANUFACTURER	LUBRICANT
Texaco	Regal AFB-2*
Mobil	Mobilplex EP No. 1
Sunoco	Prestige 42
Texaco	Multifak 2

\*Preferred lubricant because it contains rust and oxidation inhibitors.

**CONDENSER AND EVAPORATOR-FAN MOTOR BEARINGS** — The condenser-fan and evaporator-fan motors have permanently sealed bearings, so no field lubrication is necessary.

**Evaporator Fan Performance Adjustment (Fig. 50-52)** — Fan motor pulleys are factory set for speed shown in Table 1.

To change fan speeds:

1. Shut off unit power supply.
2. a. Size 016 Only: Loosen belt by loosening carriage nuts holding motor mount assembly to fan scroll side plates (A and B).
- b. Size 020-028 Only: Loosen nuts on the 2 carriage bolts in the motor mounting base. Install jacking bolt and plate under motor base (bolt and plate are shipped in installer's packet). Using bolt and plate, raise motor to top of slide and remove belt. Secure motor in this position by tightening the nuts on the carriage bolts.
3. Loosen movable-pulley flange setscrew (see Fig. 50).
4. Screw movable flange toward fixed flange to increase speed and away from fixed flange to decrease speed. Increasing fan speed increases load on motor. Do not exceed maximum speed specified in Table 1.

See Table 20 for air quantity limits.

5. Set movable flange at nearest keyway of pulley hub and tighten setscrew. (See Table 1 for speed change for each full turn of pulley flange.)
6. Replace and tighten belts. See Belt Tension Adjustment section on page 42.

To align fan and motor pulleys:

1. Loosen fan pulley setscrews.
2. Slide fan pulley along fan shaft.
3. Make angular alignment by loosening motor from mounting plate.



## Evaporator Fan Service and Replacement

48TJ016 UNITS (See Fig. 51)

NOTE: To remove belts only, follow Steps 1-6.

1. Remove filter and supply-air section panels.
2. Remove unit top panel.
3. Loosen carriage nuts A and B holding motor mount assembly to fan scroll side plates.
4. Loosen screw C.
5. Rotate motor mount assembly (with motor attached) as far as possible away from evaporator coil.
6. Remove belt.
7. Rotate motor mount assembly back past original position toward evaporator coil.
8. Remove motor mounting nuts D and E (both sides).
9. Lift motor up through top of unit.
10. Reverse above procedure to reinstall motor.
11. Check and adjust belt tension as necessary.

48TJ020-028 UNITS (See Fig. 52) — The 48TJ020-028 units use a fan motor mounting system that features a slide-out motor mounting plate. To replace or service the motor, slide out the bracket.

1. Remove the evaporator-fan access panel and the heating control access panel.
2. Remove the center post (located between the evaporator fan and heating control access panels) and all screws securing it.
3. Loosen nuts on the 2 carriage bolts in the motor mounting base.
4. Using jacking bolt under motor base, raise motor to top of slide and remove belt. Secure motor in this position by tightening the nuts on the carriage bolts.
5. Remove the belt drive.
6. Remove jacking bolt and tapped jacking bolt plate.
7. Remove the 2 screws that secure the motor mounting plate to the motor support channel.
8. Remove the 3 screws from the end of the motor support channel that interfere with the motor slide path.

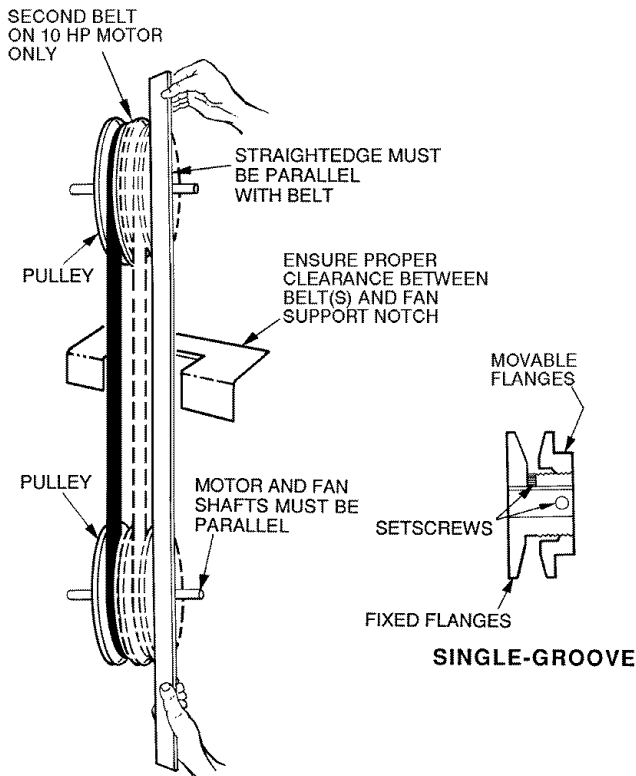

Fig. 50 — Evaporator-Fan Pulley and Adjustment

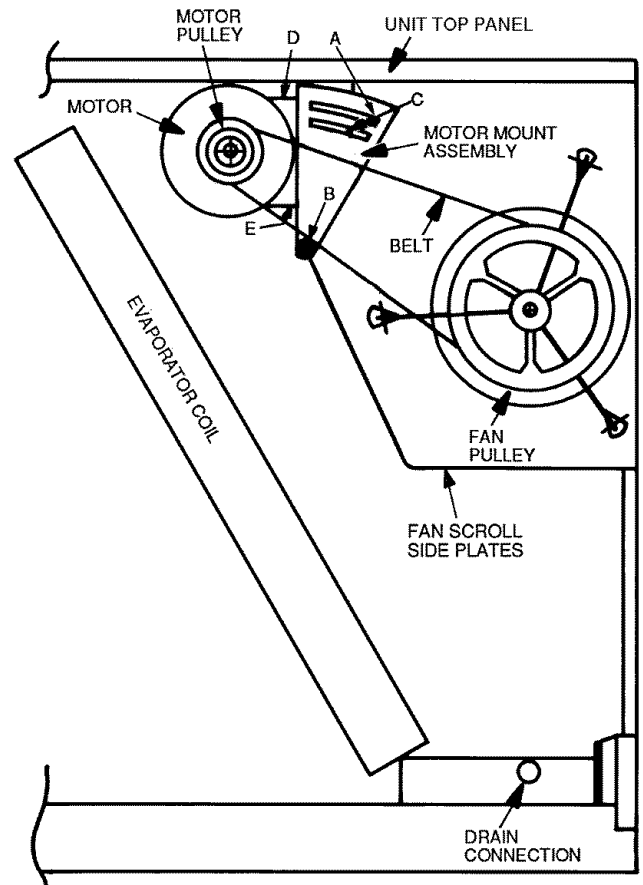
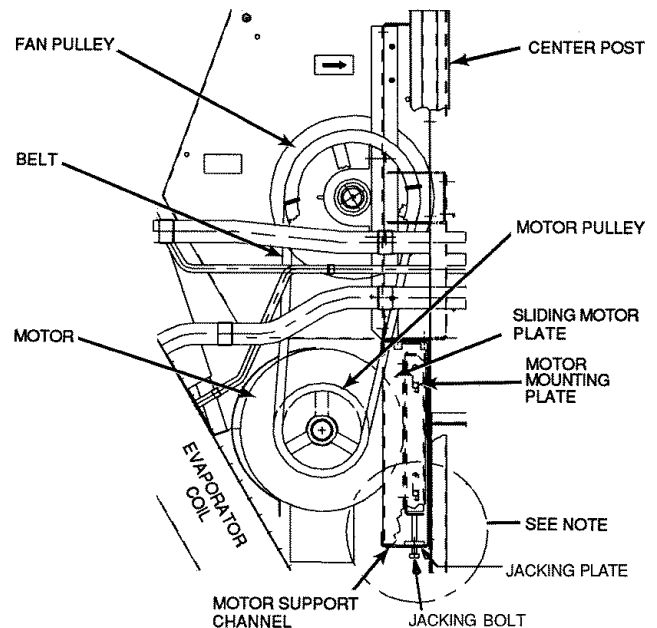

Fig. 51 — 48TJ016 Evaporator-Fan Motor Adjustment



NOTE: A 3<sup>1</sup>/<sub>2</sub>-in. bolt and threaded plate are included in the installer's packet. They should be added to the motor support channel below the motor mounting plate to aid in raising the motor. The plate part number is 50DP503842. The adjustment bolt is 3<sup>3</sup>/<sub>8</sub>-16 x 1<sup>3</sup>/<sub>4</sub> in. LG.

Fig. 52 — 48TJ020-028 Evaporator-Fan Motor Section

9. Slide out the motor and motor mounting plate.
10. Disconnect wiring connections and remove the 4 mounting bolts.
11. Remove the motor.
12. To install the new motor, reverse Steps 1-11.

**Belt Tension Adjustment** — To adjust belt tension:

1. Loosen fan motor bolts.
2. a. Size 016 Units:  
Move motor mounting plate up or down for proper belt tension ( $\frac{1}{2}$  in. deflection with one finger).
- b. Size 020-028 Units:  
Turn motor jacking bolt to move motor mounting plate up or down for proper belt tension ( $\frac{3}{8}$  in. deflection at midspan with one finger [9 lb force]).
3. Tighten nuts.
4. Adjust bolts and nut on mounting plate to secure motor in fixed position.

**Condenser-Fan Adjustment**

48TJ016,020 UNITS (Fig. 53)

1. Shut off unit power supply.
2. Remove access panel(s) closest to the fan to be adjusted.
3. Loosen fan hub setscrews.
4. Adjust fan height on shaft using a straightedge placed across the fan orifice.
5. Tighten setscrews and replace panel(s).
6. Turn on unit power.

48TJ024,028 UNITS (Fig. 54)

1. Shut off unit power supply.
2. Remove fan top-grille assembly and loosen fan hub screws.
3. Adjust fan height on unit, using a straightedge placed across the fan orifice.
4. Tighten setscrews and replace rubber hubcap to prevent hub from rusting to motor shaft.
5. Fill hub recess with permagum if rubber hubcap is missing.

**Power Failure** — Dampers have a spring return. In event of power failure, dampers will return to fully closed position until power is restored. *Do not manually operate economizer motor.*

**Refrigerant Charge** — Amount of refrigerant charge is listed on unit nameplate and in Table I. Refer to Carrier

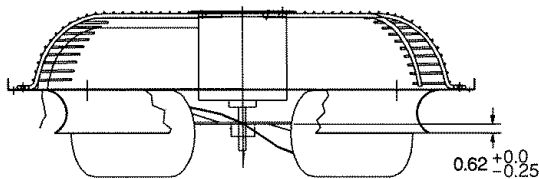

NOTE: Dimensions are in inches.

**Fig. 53 — Condenser Fan Adjustment, 48TJ016,020**

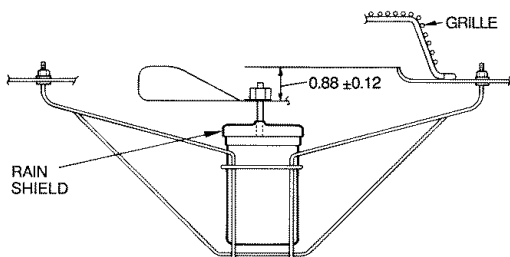

NOTE: Dimensions are in inches.

**Fig. 54 — Condenser-Fan Adjustment, 48TJ024,028**

GTAC II; Module 5; Charging, Recovery, Recycling, and Reclamation section for charging methods and procedures. Unit panels must be in place when unit is operating during charging procedure.

NOTE: Do not use recycled refrigerant as it may contain contaminants.

NO CHARGE — Use standard evacuating techniques. After evacuating system, weigh in the specified amount of refrigerant (refer to Table I).

LOW CHARGE COOLING — Using cooling charging chart (see Fig. 55), add or remove refrigerant until conditions of the chart are met. Note that charging chart is different from those normally used. An accurate pressure gage and temperature-sensing device is required. Charging is accomplished by ensuring the proper amount of liquid sub-cooling. Measure liquid line pressure at the liquid line service valve using pressure gage. Connect temperature sensing device to the liquid line near the liquid line service valve and insulate it so that outdoor ambient temperature does not affect reading.

TO USE THE COOLING CHARGING CHART — Use the above temperature and pressure readings, and find the intersection point on the cooling charging chart. If intersection point on chart is above line, add refrigerant. If intersection point on chart is below line, carefully recover some of the charge. Recheck suction pressure as charge is adjusted.

NOTE: Indoor-air cfm must be within normal operating range of unit. All outdoor fans must be operating.

The TXV (thermostatic expansion valve) is set to maintain between 15 and 20 degrees of superheat at the compressors. The valves are factory set and should not require re-adjustment.

MOISTUREMISER™ SYSTEM CHARGING — The system charge for units with the MoistureMiSer option is greater than that of the standard unit alone. The charge for units with this option is indicated on the unit nameplate drawing. To charge systems using the MoistureMiSer dehumidification package, fully evacuate, recover, and re-charge the system to the nameplate specified charge level. To check or adjust refrigerant charge on systems using the MoistureMiSer dehumidification package, charge per the standard subcooling charts. The subcooler MUST be deenergized to use the charging charts. The charts reference a liquid pressure (psig) and temperature at a point between the condenser coil and the subcooler coil. A tap is provided on the unit to measure liquid pressure entering the subcooler (leaving the condenser).

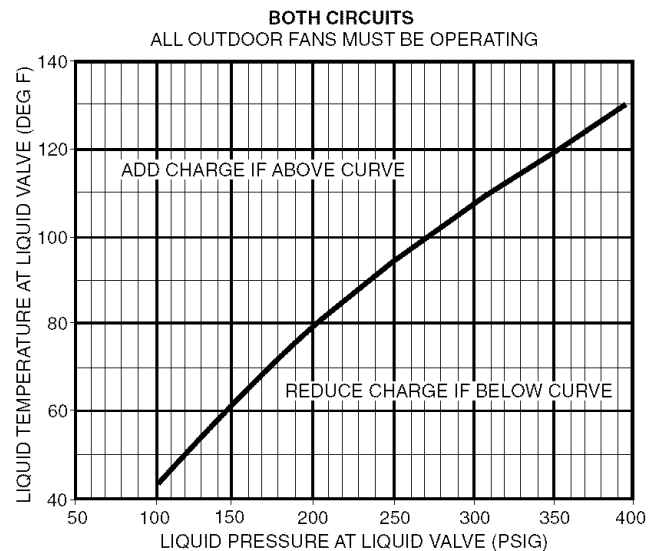

**Fig. 55 — Cooling Charging Chart**

## Gas Valve Adjustment

**NATURAL GAS** — The gas valve opens and closes in response to the thermostat or limit control.

When power is supplied to valve terminals D1 and C2, the main valve opens to its preset position.

The regular factory setting is stamped on the valve body (3.3 in. wg).

To adjust regulator:

1. Set thermostat at setting for no call for heat.
2. Turn main gas valve to OFF position.
3. Remove 1/8-in. pipe plug from manifold or gas valve pressure tap connection. Install a suitable pressure-measuring device.
4. Set main gas valve to ON position.
5. Set thermostat at setting to call for heat.
6. Remove screw cap covering regulator adjustment screw (see Fig. 56).
7. Turn adjustment screw clockwise to increase pressure or counterclockwise to decrease pressure.
8. Once desired pressure is established, set thermostat setting for no call for heat, turn off main gas valve, remove pressure-measuring device, and replace 1/8-in. pipe plug and screw cap.

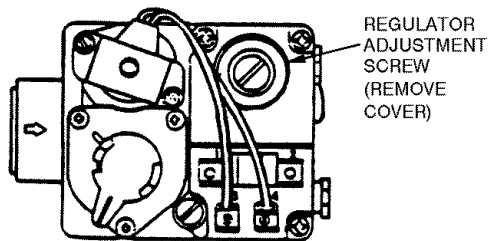

Fig. 56 — Gas Valve

**Main Burners** — For all applications, main burners are factory set and should require no adjustment.

### MAIN BURNER REMOVAL

1. Shut off (field-supplied) manual main gas valve.
2. Shut off power to unit.
3. Remove unit control box access panel, burner section access panel, and center post (see Fig. 4 and 5).
4. Disconnect gas piping from gas valve inlet.
5. Remove wires from gas valve.
6. Remove wires from rollout switch.
7. Remove sensor wire and ignitor cable from IGC board.
8. Remove 2 screws securing manifold bracket to basepan.
9. Remove 2 screws that hold the burner support plate flange to the vestibule plate.
10. Lift burner assembly out of unit.

### CLEANING AND ADJUSTMENT

1. Remove burner rack from unit as described in Main Burner Removal section above.
2. Inspect burners, and if dirty, remove burners from rack.
3. Using a soft brush, clean burners and crossover port as required.
4. Adjust spark gap. See Fig. 57.
5. Reinstall burners on rack.
6. Reinstall burner rack as described above.

**Filter Drier** — Replace whenever refrigerant system is exposed to atmosphere.

## Protective Devices

### COMPRESSOR PROTECTION

**Phase Protection** — On 48TJ016 and 020 units, the phase monitor relay (PMR) will monitor the sequence of the 3-phase electrical system to provide phase reversal protection. The PMR will also monitor the 3-phase voltage inputs to provide phase loss protection for the 3-phase device.

**Overcurrent** — Each compressor has internal line break motor protection, except the circuit no. 1 on the 48TJ028 units. Compressor no. 1 on the 48TJ028 unit uses an electronic module, located with the compressor junction box, to provide motor protection. This electronic module monitors winding and discharge temperatures. If these temperatures reach the trip values, the module interrupts the control line and causes the compressor to switch off.

**Crankcase Heater** — Only the 48TJ028 unit and units with optional MoistureMiSer™ dehumidification system are equipped with a 70-watt crankcase heater to prevent absorption of liquid refrigerant by oil in the crankcase when the compressor is idle. The crankcase heater is energized whenever there is a main power to the unit and the compressor is not energized.

**IMPORTANT:** After a prolonged shutdown or servicing, energize the crankcase heaters for 24 hours before starting the compressors.

**Compressor Lockout** — If any of the safeties (high-pressure, low-pressure, freeze protection thermostat, compressor internal thermostat) trip, or if there is loss of power to the compressors, the cooling lockout (CLO) will lock the compressors off. To reset, manually move the thermostat setting.

**EVAPORATOR-FAN MOTOR PROTECTION** — A manual reset, calibrated trip, magnetic circuit breaker protects against overcurrent. Do not bypass connections or increase the size of the breaker to correct trouble. Determine the cause and correct it before resetting the breaker.

**CONDENSER-FAN MOTOR PROTECTION** — Each condenser-fan motor is internally protected against overtemperature.

**HIGH-PRESSURE AND LOW-PRESSURE SWITCHES** — If either switch trips, or if the compressor overtemperature switch activates, that refrigerant circuit will be automatically locked out by the CLO. To reset, manually move the thermostat setting.

**FREEZE PROTECTION THERMOSTAT (FPT)** — An FPT is located on the top and bottom of the evaporator coil. They detect frost build-up and turn off the compressor, allowing the coil to clear. Once the frost has melted, the compressor can be reenergized by resetting the compressor lockout.

**Relief Devices** — All units have relief devices to protect against damage from excessive pressures (i.e., fire). These devices protect the high and low side.

**Control Circuit, 24-V** — This control circuit is protected against overcurrent by a 3.2 amp circuit breaker. Breaker can be reset. If it trips, determine cause of trouble before resetting. See Fig. 58 and 59 for typical wiring diagram and component arrangement.

**Replacement Parts** — A complete list of replacement parts may be obtained from any Carrier distributor upon request.

**Diagnostic IGC Control LEDs** — The IGC board has LEDs for diagnostic purposes. Refer to Troubleshooting section on page 48.

**Optional Hinged Access Doors** — When the optional service package is ordered or the if the hinged access doors option is ordered, the unit will be provided with external and internal hinged access doors to facilitate service.

Four external hinged access doors are provided. All external doors are provided with 2 large 1/4 turn latches with folding bail-type handles. (Compressor access doors have one latch.) A single door is provided for filter and drive access. One door is provided for control box access. The control box access door is interlocked with the non-fused disconnect which must be in the OFF position to open the door. Two doors are provided for access to the compressor compartment.

Two internal access doors are provided inside the filter/drive access door. The filter access door (on the left) is secured by 2 small 1/4 turn latches with folding bail-type handles. This door must be opened prior to opening the drive access door. The drive access door is shipped with 2 sheet metal screws holding the door closed. Upon initial opening of the door, these screws may be removed and discarded. The door is then held shut by the filter access door, which closes over it.

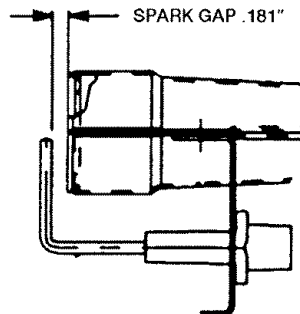
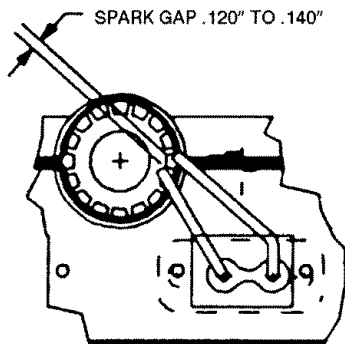
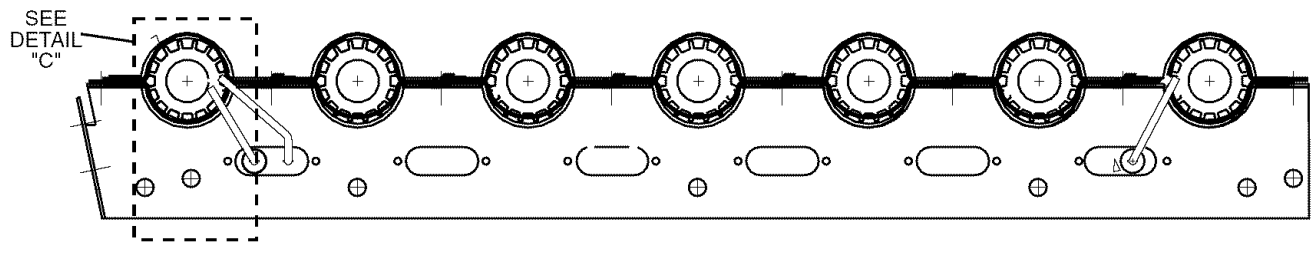
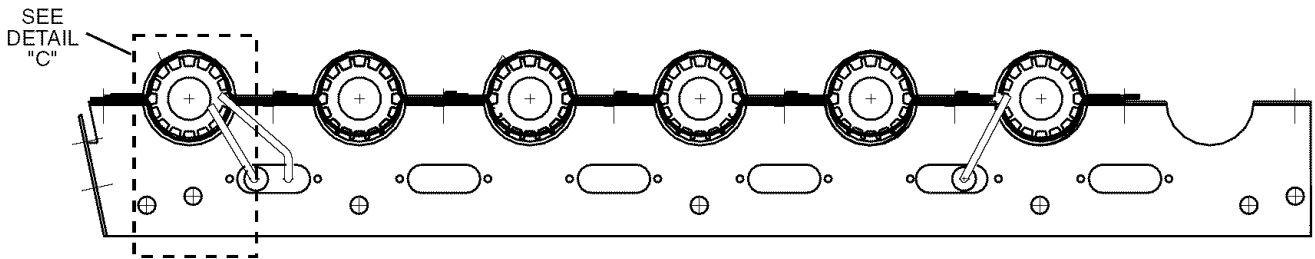
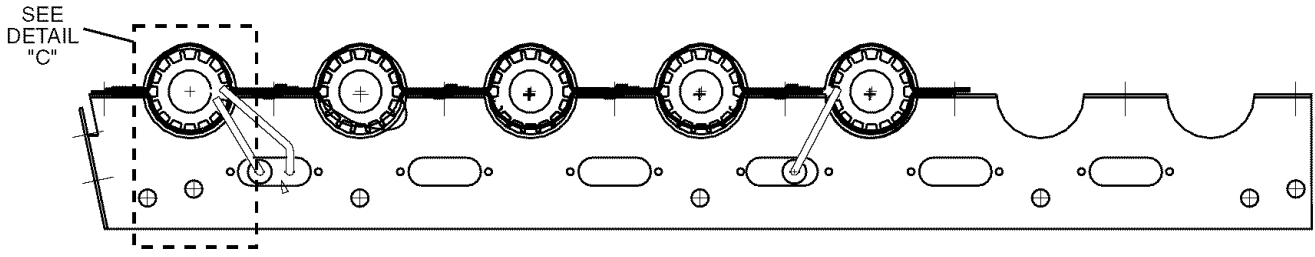

DETAIL "C"

Fig. 57 — Spark Gap Adjustment

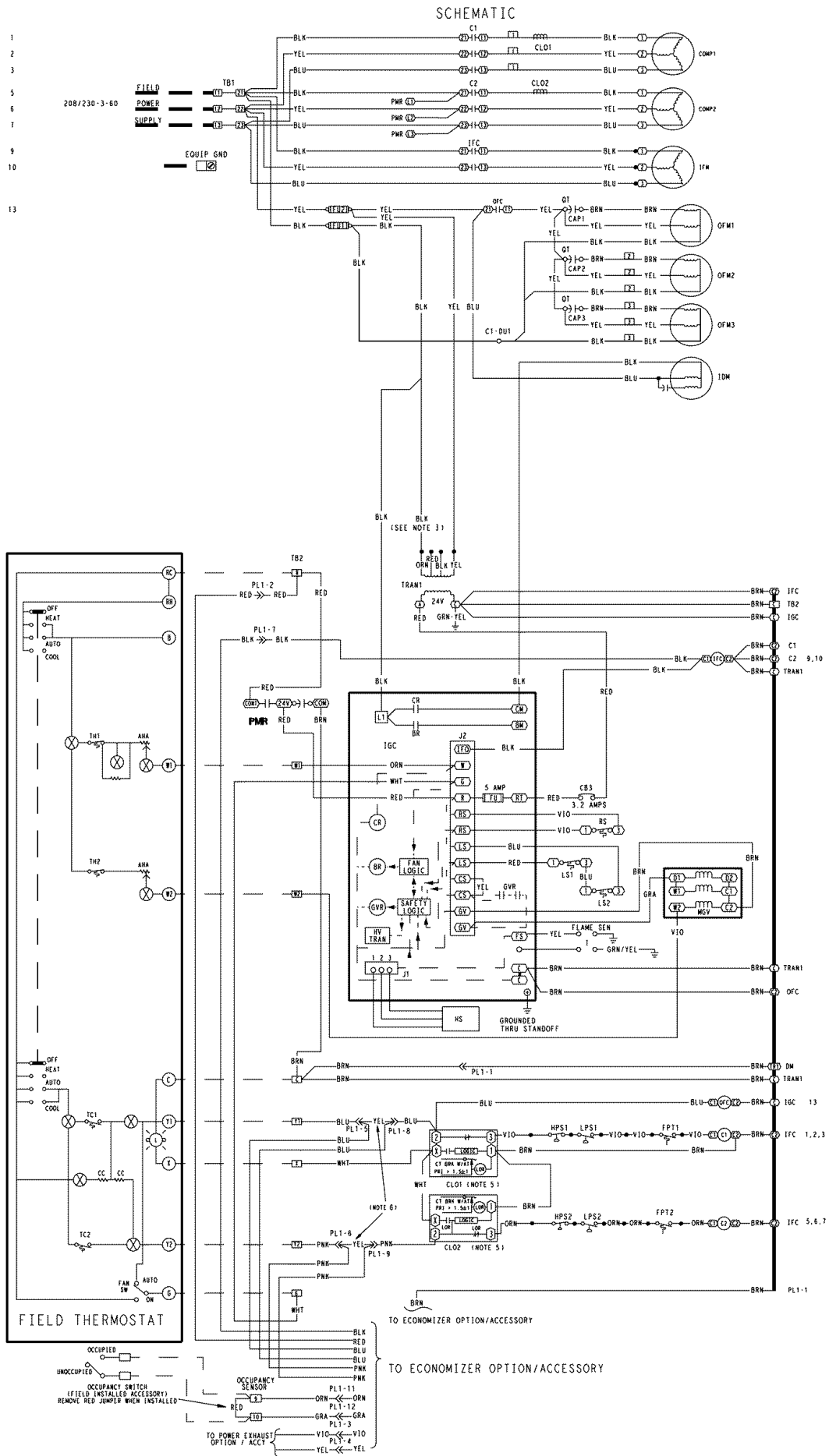

**Fig. 58 — Typical Wiring Schematic (48TJ016, 208/230-V Shown)**

# COMPONENT ARRANGEMENT

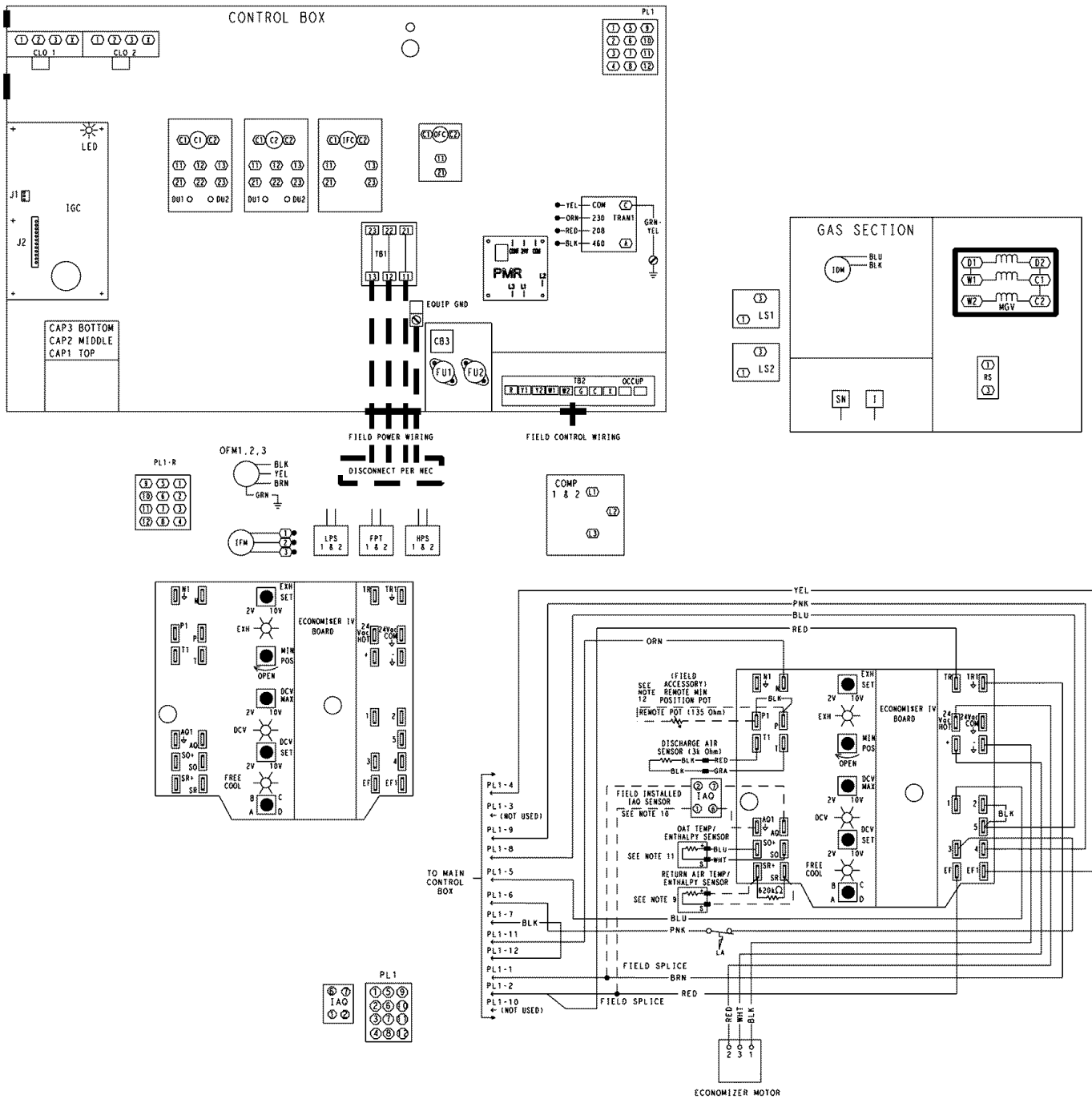















Fig. 59 — Typical Component Arrangement (48TJ016 Unit Shown)

## LEGEND AND NOTES FOR FIG. 58 AND 59

### LEGEND

<b>AHA</b>	— Adjustable, Heat Anticipator	<b>SN</b>	— Sensor
<b>BKR W/AT</b>	— Breaks with Amp Turns	<b>TB</b>	— Terminal Block
<b>C</b>	— Contactor, Compressor	<b>TC</b>	— Thermostat Cooling
<b>CAP</b>	— Capacitor	<b>TH</b>	— Thermostat Heating
<b>CB</b>	— Circuit Breaker	<b>TRAN</b>	— Transformer
<b>CC</b>	— Cooling Compensator		Terminal (Marked)
<b>CLO</b>	— Compressor Lockout		Terminal (Unmarked)
<b>COMP</b>	— Compressor Motor		Terminal Block
<b>DM</b>	— Damper Motor		Splice
<b>DU</b>	— Dummy Terminal		Factory Wiring
<b>EQUIP</b>	— Equipment		Field Control Wiring
<b>FPT</b>	— Freeze Protection Thermostat		Accessory or Optional Wiring
<b>FU</b>	— Fuse		To indicate common potential only; not to represent wiring.
<b>GND</b>	— Ground		Economizer Motor
<b>HPS</b>	— High-Pressure Switch		Remote POT Field Accessory
<b>IAQ</b>	— Indoor Air Quality Sensor		OAT Sensor
<b>IDM</b>	— Induced-Draft Motor		Disch Air Sensor
<b>IFM</b>	— Indoor-Fan Motor		RAT Accessory Sensor
<b>IGC</b>	— Integrated Gas Unit Controller		Low Ambient Lockout Switch
<b>L</b>	— Light		
<b>LED</b>	— Light Emitting Diode		
<b>LPS</b>	— Low-Pressure Switch		
<b>LS</b>	— Limit Switch		
<b>MGV</b>	— Main Gas Valve		
<b>NEC</b>	— National Electrical Code		
<b>OAT</b>	— Outdoor Air Temperature Sensor		
<b>OCCUP</b>	— Occupancy Sensor		
<b>OFC</b>	— Outdoor-Fan Contactor		
<b>OFM</b>	— Outdoor-Fan Motor		
<b>PL</b>	— Plug Assembly		
<b>PMR</b>	— Phase Monitor Relay		
<b>QT</b>	— Quadruple Terminal		
<b>RAT</b>	— Return Air Temperature Sensor		
<b>RS</b>	— Rollout Switch		

### NOTES:

1. Compressor and/or fan motor(s) thermally protected three phase motors protected against primary single phasing conditions.
2. If any of the original wire furnished must be replaced, it must be replaced with Type 90° C or its equivalent.
3. TRAN1 is wired for 230-v operation. If unit is 208 v, disconnect the black wires from the ORN TRAN wire and reconnect to the RED TRAN wire. Apply wirenuts to wires.
4. CB1, 2 Must Trip Amps are equal to or less than 156% FLA. IFCB 140%.
5. The CLO locks out the compressor to prevent short cycling on compressor overload and safety devices; before replacing CLO check these devices.
6. Jumpers are omitted when unit is equipped with economizer.
7. Number(s) indicates the line location of used contacts. A bracket over (2) numbers signifies a single pole, double throw contact. An underlined number signifies a normally closed contact. Plain (no line) number signifies a normally open contact.
8. Remove jumper between RC and RH.
9. 620 Ohm, 1 watt, 5% resistor should be removed only when using differential enthalpy or dry bulb.
10. If a separate field-supplied 24 v transformer is used for the IAQ sensor power supply, it cannot have the secondary of the transformer grounded.
11. OAT sensor is shipped inside unit and must be relocated in the field for proper operation.
12. For field-installed remote minimum position POT, remove black wire jumper between P and P1 and set control minimum position POT to the minimum position.

## TROUBLESHOOTING

**Unit Troubleshooting** — Refer to Tables 27-29 and Fig. 60.

**EconoMi\$erIV Troubleshooting** — See Table 30 for EconoMi\$erIV logic.

A functional view of the EconoMi\$erIV is shown in Fig. 61. Typical settings, sensor ranges, and jumper positions are also shown. An EconoMi\$erIV simulator program is available from Carrier to help with EconoMi\$erIV training and troubleshooting.

**ECONOMI\$ERIV PREPARATION** — This procedure is used to prepare the EconoMi\$erIV for troubleshooting. No troubleshooting or testing is done by performing the following procedure.

**NOTE:** This procedure requires a 9-v battery, 1.2 kilo-ohm resistor, and a 5.6 kilo-ohm resistor which are not supplied with the EconoMi\$erIV.

**IMPORTANT:** Be sure to record the positions of all potentiometers before starting troubleshooting.

1. Disconnect power at TR and TR1. All LEDs should be off. Exhaust fan contacts should be open.
2. Disconnect device at P and P1.
3. Jumper P to P1.
4. Disconnect wires at T and T1. Place 5.6 kilo-ohm resistor across T and T1.
5. Jumper TR to 1.
6. Jumper TR to N.
7. If connected, remove sensor from terminals S<sub>O</sub> and +. Connect 1.2 kilo-ohm 4074EJM checkout resistor across terminals S<sub>O</sub> and +.
8. Put 620-ohm resistor across terminals S<sub>R</sub> and +.
9. Set minimum position, DCV set point, and exhaust potentiometers fully CCW (counterclockwise).
10. Set DCV maximum position potentiometer fully CW (clockwise).
11. Set enthalpy potentiometer to D.
12. Apply power (24 vac) to terminals TR and TR1.

**DIFFERENTIAL ENTHALPY** — To check differential enthalpy:

1. Make sure EconoMi\$erIV preparation procedure has been performed.
2. Place 620-ohm resistor across S<sub>O</sub> and +.
3. Place 1.2 kilo-ohm resistor across S<sub>R</sub> and +. The Free Cool LED should be lit.
4. Remove 620-ohm resistor across S<sub>O</sub> and +. The Free Cool LED should turn off.
5. Return EconoMi\$erIV settings and wiring to normal after completing troubleshooting.

**SINGLE ENTHALPY** — To check single enthalpy:

1. Make sure EconoMi\$erIV preparation procedure has been performed.
2. Set the enthalpy potentiometer to A (fully CCW). The Free Cool LED should be lit.
3. Set the enthalpy potentiometer to D (fully CW). The Free Cool LED should turn off.
4. Return EconoMi\$erIV settings and wiring to normal after completing troubleshooting.

**DCV (Demand Controlled Ventilation) AND POWER EXHAUST** — To check DCV and Power Exhaust:

1. Make sure EconoMi\$erIV preparation procedure has been performed.
2. Ensure terminals AQ and AQ1 are open. The LED for both DCV and Exhaust should be off. The actuator should be fully closed.
3. Connect a 9-v battery to AQ (positive node) and AQ1 (negative node). The LED for both DCV and Exhaust

should turn on. The actuator should drive to between 90 and 95% open.

4. Turn the Exhaust potentiometer CW until the Exhaust LED turns off. The LED should turn off when the potentiometer is approximately 90%. The actuator should remain in position.
5. Turn the DCV set point potentiometer CW until the DCV LED turns off. The DCV LED should turn off when the potentiometer is approximately 9-v. The actuator should drive fully closed.
6. Turn the DCV and Exhaust potentiometers CCW until the Exhaust LED turns on. The exhaust contacts will close 30 to 120 seconds after the Exhaust LED turns on.
7. Return EconoMi\$erIV settings and wiring to normal after completing troubleshooting.

**DCV MINIMUM AND MAXIMUM POSITION** — To check the DCV minimum and maximum position:

1. Make sure EconoMi\$erIV preparation procedure has been performed.
2. Connect a 9-v battery to AQ (positive node) and AQ1 (negative node). The DCV LED should turn on. The actuator should drive to between 90 and 95% open.
3. Turn the DCV Maximum Position potentiometer to midpoint. The actuator should drive to between 20 and 80% open.
4. Turn the DCV Maximum Position potentiometer to fully CCW. The actuator should drive fully closed.
5. Turn the Minimum Position potentiometer to midpoint. The actuator should drive to between 20 and 80% open.
6. Turn the Minimum Position Potentiometer fully CW. The actuator should drive fully open.
7. Remove the jumper from TR and N. The actuator should drive fully closed.
8. Return EconoMi\$erIV settings and wiring to normal after completing troubleshooting.

**SUPPLY-AIR INPUT** — To check supply-air input:

1. Make sure EconoMi\$erIV preparation procedure has been performed.
2. Set the Enthalpy potentiometer to A. The Free Cool LED turns on. The actuator should drive to between 20 and 80% open.
3. Remove the 5.6 kilo-ohm resistor and jumper T to T1. The actuator should drive fully open.
4. Remove the jumper across T and T1. The actuator should drive fully closed.
5. Return EconoMi\$erIV settings and wiring to normal after completing troubleshooting.

**ECONOMI\$ER IV TROUBLESHOOTING COMPLETION** — This procedure is used to return the EconoMi\$erIV to operation. No troubleshooting or testing is done by performing the following procedure.

1. Disconnect power at TR and TR1.
2. Set enthalpy potentiometer to previous setting.
3. Set DCV maximum position potentiometer to previous setting.
4. Set minimum position, DCV set point, and exhaust potentiometers to previous settings.
5. Remove 620-ohm resistor from terminals S<sub>R</sub> and +.
6. Remove 1.2 kilo-ohm checkout resistor from terminals S<sub>O</sub> and +. If used, reconnect sensor from terminals S<sub>O</sub> and +.
7. Remove jumper from TR to N.
8. Remove jumper from TR to 1.
9. Remove 5.6 kilo-ohm resistor from T and T1. Reconnect wires at T and T1.
10. Remove jumper from P to P1. Reconnect device at P and P1.
11. Apply power (24 vac) to terminals TR and TR1.



**Table 27 — Cooling Service Analysis**

<b>PROBLEM</b>	<b>CAUSE</b>	<b>REMEDY</b>
<b>Compressor and Condenser Fan Will Not Start.</b>	Power failure.	Call power company.
	Fuse blown or circuit breaker tripped.	Replace fuse or reset circuit breaker.
	Defective thermostat, contactor, transformer, or control relay.	Replace component.
	Insufficient line voltage.	Determine cause and correct.
	Incorrect or faulty wiring.	Check wiring diagram and rewire correctly.
	Thermostat setting too high.	Lower thermostat setting below room temperature.
	Three phase power incorrectly connected (sizes 016 and 020 only). Indicated by flashing red LED on Phase Monitor Relay (PMR) board (see Control Box Component Arrangement for location).	Correct field power phasing.
<b>Compressor Will Not Start but Condenser Fan Runs.</b>	Faulty wiring or loose connections in compressor circuit.	Check wiring and repair or replace.
	Compressor motor burned out, seized, or internal overload open.	Determine cause. Replace compressor.
	Defective overload.	Determine cause and replace.
	Compressor locked out	Determine cause for safety trip and reset lockout.
	One leg of 3-phase power dead.	Replace fuse or reset circuit breaker. Determine cause.
<b>Compressor Cycles (other than normally satisfying thermostat).</b>	Refrigerant overcharge or undercharge.	Recover refrigerant, evacuate system, and recharge to nameplate.
	Defective compressor.	Replace and determine cause.
	Insufficient line voltage.	Determine cause and correct.
	Blocked condenser.	Determine cause and correct.
	Defective overload.	Determine cause and replace.
	Defective thermostat.	Replace thermostat.
	Faulty condenser-fan motor.	Replace.
Restriction in refrigerant system.	Locate restriction and remove.	
<b>Compressor Operates continuously.</b>	Dirty air filter.	Replace filter.
	Unit undersized for load.	Decrease load or increase unit size.
	Thermostat set too low.	Reset thermostat.
	Low refrigerant charge.	Locate leak, repair, and recharge.
	Air in system.	Recover refrigerant, evacuate system, and recharge.
	Condenser coil dirty or restricted.	Clean coil or remove restriction.
<b>Excessive Head Pressure.</b>	Dirty air filter.	Replace filter.
	Dirty condenser coil.	Clean coil.
	Refrigerant overcharged.	Recover excess refrigerant.
	Faulty TXV.	1. Check TXV bulb mounting and secure tightly to suction line. 2. Replace TXV if stuck open or closed.
	Air in system.	Recover refrigerant, evacuate system, and recharge.
	Condenser air restricted or air short-cycling.	Determine cause and correct.
<b>Head Pressure Too Low.</b>	Low refrigerant charge.	Check for leaks, repair, and recharge.
	Restriction in liquid tube.	Remove restriction.
<b>Excessive Suction Pressure.</b>	High heat load.	Check for source and eliminate.
	Faulty TXV.	1. Check TXV bulb mounting and secure tightly to suction line. 2. Replace TXV if stuck open or closed.
	Refrigerant overcharged.	Recover excess refrigerant.
<b>Suction Pressure Too Low.</b>	Dirty air filter.	Replace filter.
	Low refrigerant charge.	Check for leaks, repair, and recharge.
	Metering device or low side restricted.	Remove source of restriction.
	Faulty TXV.	1. Check TXV bulb mounting and secure tightly to suction line. 2. Replace TXV if stuck open or closed.
	Insufficient evaporator airflow.	Increase air quantity. Check filter and replace if necessary.
	Temperature too low in conditioned area.	Reset thermostat.
	Field-installed filter drier restricted.	Replace.

**LEGEND**

**TXV** — Thermostatic Expansion Valve

**Table 28 — Heating Service Analysis**

PROBLEM	CAUSE	REMEDY
<b>Burners Will Not Ignite.</b>	Misaligned spark electrodes.	Check flame ignition and sensor electrode positioning. Adjust as needed.
	No gas at main burners.	Check gas line for air; purge as necessary. After purging gas line of air, allow gas to dissipate for at least 5 minutes before attempting to relight unit. Check gas valve.
	Water in gas line.	Drain water and install drip leg to trap water.
	No power to furnace.	Check power supply, fuses, wiring, and circuit breaker.
	No 24 v power supply to control circuit.	Check transformer. Transformers with internal overcurrent protection require a cool-down period before resetting. Check 24-v circuit breaker; reset if necessary.
	Miswired or loose connections.	Check all wiring and wire nut connections.
	Burned-out heat anticipator in thermostat.	Replace thermostat.
	Broken thermostat wires.	Run continuity check. Replace wires if necessary.
<b>Inadequate Heating.</b>	Dirty air filter.	Clean or replace filter as necessary.
	Gas input to unit too low.	Check gas pressure at manifold. Check gas meter for input. If too low, increase manifold pressure or replace with correct orifices.
	Unit undersized for application.	Replace with proper unit or add additional unit.
	Restricted airflow.	Clean filter, replace filter, or remove any restrictions.
	Blower speed too low.	Install alternate motor, if applicable, or adjust pulley to increase fan speed.
	Limit switch cycles main burners.	Check rotation of blower, thermostat heat anticipator settings, and temperature rise of unit. Adjust as needed.
	Too much outdoor air.	Adjust minimum position. Check economizer operation.
<b>Poor Flame Characteristics.</b>	Incomplete combustion (lack of combustion air) results in: Aldehyde odors, CO, sooting flame, or floating flame.	Check all screws around flue outlets and burner compartment. Tighten as necessary.
		Cracked heat exchanger.
		Overfired unit — reduce input, change orifices, or adjust gas line or manifold pressure.
		Check vent for restriction. Clean as necessary. Check orifice to burner alignment.
<b>Burners Will Not Turn Off.</b>	Unit is locked into Heating mode for a one minute minimum.	Wait until mandatory one-minute time period has elapsed or cycle power to unit.

**Table 29 — MoistureMiSer™ Dehumidification Subcooler Service Analysis**

PROBLEM	CAUSE	REMEDY
<b>Subcooler Will Not Energize</b>	No power to subcooler control transformer.	Check power source. Ensure all wire connections are tight.
	No power from subcooler control transformer to liquid line three-way valve.	1. Fuse open; check fuse. Ensure continuity of wiring. 2. Subcooler control low-pressure switch open. Cycle unit off and allow low-pressure switch to reset. Replace switch if it will not close. 3. Transformer bad; check transformer.
	Liquid line three-way valve will not operate.	1. Solenoid coil defective; replace. 2. Solenoid valve stuck closed; replace.
<b>Subcooler Will Not Deenergize</b>	Liquid line three-way valve will not close.	Valve is stuck open; replace.
<b>Low System Capacity</b>	Low refrigerant charge or frosted coil.	1. Check charge amount. See system charging section. 2. Evaporator coil frosted; check and replace subcooler control low-pressure switch if necessary.

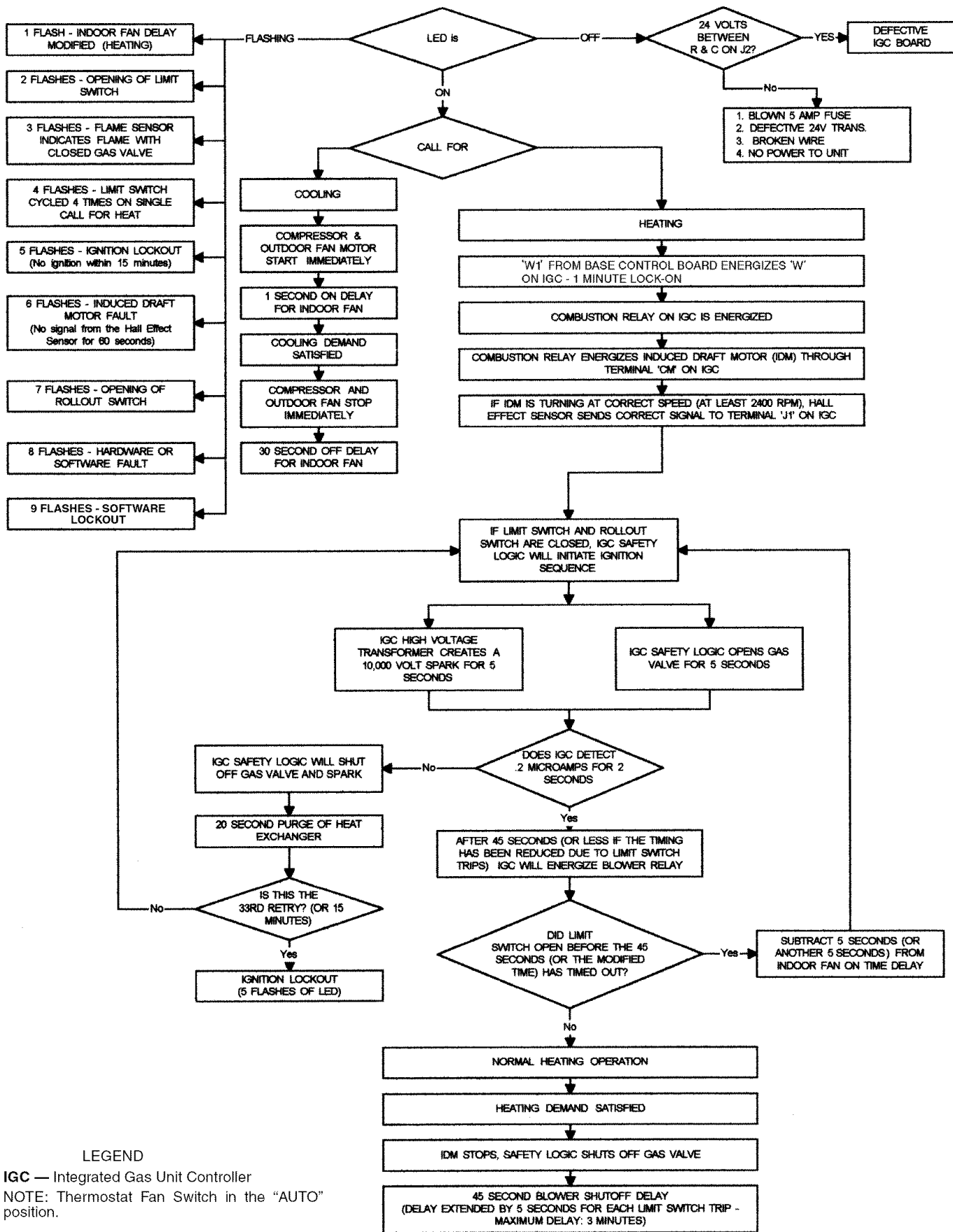

**LEGEND**

**IGC** — Integrated Gas Unit Controller

**NOTE:** Thermostat Fan Switch in the "AUTO" position.

**Fig. 60 — IGC Control (Heating and Cooling)**

**Table 30 — EconoMiSerIV Input/Output Logic**

Demand Control Ventilation (DCV)	INPUTS				OUTPUTS				
	Enthalpy*		Y1	Y2	Compressor		N Terminal†		
	Outdoor	Return			Stage 1	Stage 2	Occupied	Unoccupied	
Below set (DCV LED Off)	High (Free Cooling LED Off)	Low	On	On	On	On	Minimum position		Closed
			On	Off	On	Off			
			Off	Off	Off	Off			
Above set (DCV LED On)	High (Free Cooling LED Off)	Low	On	On	On	On	Modulating†† (between min. position and DCV maximum)		Modulating†† (between closed and DCV maximum)
			On	Off	On	Off			
			Off	Off	Off	Off			
Below set (DCV LED Off)	Low (Free Cooling LED On)	High	On	On	On	Off	Modulating***		Modulating†††
			On	Off	Off	Off			
			Off	Off	Off	Off			

\*For single enthalpy control, the module compares outdoor enthalpy to the ABCD set point.  
 †Power at N terminal determines Occupied/Unoccupied setting: 24 vac (Occupied), no power (Unoccupied).  
 \*\*Modulation is based on the supply air sensor signal.  
 ††Modulation is based on the DCV signal.

\*\*\*Modulation is based on the greater of DCV and supply air sensor signals, between minimum position and either maximum position (DCV) or fully open (supply air signal).  
 †††Modulation is based on the greater of DCV and supply air sensor signals, between closed and either maximum position (DCV) or fully open (supply air signal).

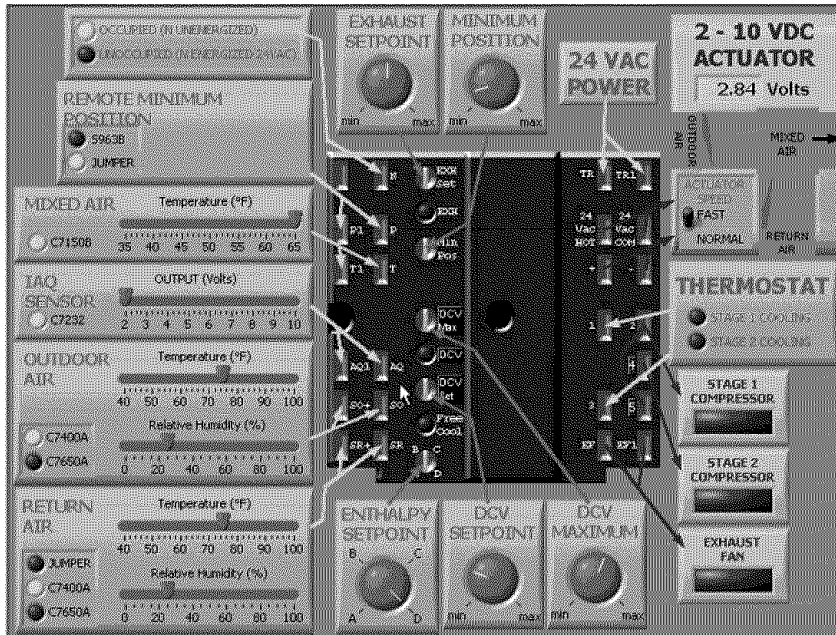

**Fig. 61 — EconoMiSerIV Functional View**

## INDEX

- Altitude compensation 10
- Burner spark gap 44
- Carrier Comfort Network® 17
- Changeover set points 26
- Charging chart, refrigerant 42
- Clearance 5, 6
- CO<sub>2</sub> sensor
  - Configuration 28
  - Settings 27, 29
- Combustion blower wheel 40
- Compressor
  - Lubrication 40
  - Mounting 31
  - Rotation 31
- Concentric duct 9
- Condensate drain
  - Cleaning 40
  - Location 9, 10
- Condenser coil 7
  - Cleaning 39
- Condenser fan 7
  - Adjustment 42
- Control circuit
  - Wiring 11
- Convenience outlet 12
- Crankcase heater 31, 43
- Demand control ventilation 28
  - Dehumidification 29
- Dimensions 3-6
- Ductwork 9
- EconoMi\$erIV 23-29
  - Control mode 25
  - Controller wiring 24
  - Demand ventilation control 28
  - Dry bulb changeover 25
  - Enthalpy sensor 26
  - Troubleshooting 48, 52
  - Usage 25
  - Wiring 24
- EconoMi\$er2 23, 24
- Electrical connections 11
- Electrical data 13
- Enthalpy changeover set points 27
- Error codes 51
- Evaporator coil 7
  - Cleaning 39
- Evaporator fan motor
  - Lubrication 40
  - Motor data 36
  - Mounting 41
  - Performance 32-34
  - Pulley adjustment 41
  - Pulley setting 7, 35
  - Speed 7
- Filter
  - Cleaning 40
  - Size 8
- Filter drier 43
- Flue collector box 40
- Flue gas passageways 40
- Flue hood 9
- Freeze protection thermostat 8
- Gas connection 8
- Gas input 8
- Gas piping 11
- Gas pressure 1, 8, 11
- Heat anticipator settings 8, 11
- High-pressure switch 8, 43
- Hinged access doors 44
- Horizontal adapter roof curb 2
- Humidistat 29
- Indoor air quality sensor 17
- Integrated gas controller 51
  - Error codes 51
- Liquid propane 10
- Low-pressure switch 8, 43
- Main burners 40, 43
- Manual outdoor air damper 14
- MoistureMi\$er™
  - dehumidification 29-31, 35, 42, 50
- Motormaster® I control 15
- Motormaster V control 16
- Mounting
  - Compressor 31
  - Unit 2
- Natural gas 8, 43
- Non-fused disconnect 12
- Operating limits 16
- Operating sequence 36-38
  - Cooling 36
  - EconoMi\$erIV 36, 37
  - EconoMi\$er2 with PremierLink™ control 37, 38
  - Heating 36, 37
- Outdoor air hood 14
- Outdoor air temperature sensor 17, 25
- Outdoor air inlet screens
  - Cleaning 40
  - Dimensions 8
- Physical data 7, 8
- Power supply 11
  - Wiring 11
- PremierLink controls 17-20
- Pressure, drop
  - Economizer 35
  - MoistureMi\$er 35
- Pressure switches
  - High pressure 8
  - Low pressure 8
- Refrigerant
  - Charge 7, 42
  - Type 7
- Refrigerant service ports 31
- Replacement parts 43
- Return air filter 8, 36
- Return air temperature sensor 26
- Rigging unit 2, 4
- Roof curb
  - Assembly 2
  - Dimensions 2, 3
  - Leveling tolerances 2, 3
  - Weight 7
- Safety considerations 1
- Service 39-47
- Start-up 31-38
- Start-up checklist CL-1
- Supply-air temperature sensor 17, 25
- Thermostat 12
- Troubleshooting 48-52
- Weight
  - Corner 5, 6
  - EconoMi\$erIV 5-7
  - Maximum 4
  - Unit 5-7
- Wind baffle 15, 16
- Wiring
  - EconoMi\$erIV 24
  - EconoMi\$er2 24
  - Humidistat 30
  - Non-fused disconnect 12
  - Power connections 11
  - PremierLink 18, 20
  - Thermostat 12
  - Unit 45, 46

## SERVICE TRAINING

**Packaged Service Training** programs are an excellent way to increase your knowledge of the equipment discussed in this manual, including:

- Unit Familiarization
- Installation Overview
- Maintenance
- Operating Sequence

A large selection of product, theory, and skills programs are available, using popular video-based formats and materials. All include video and/or slides, plus companion book.

**Classroom Service Training** which includes “hands-on” experience with the products in our labs can mean increased confidence that really pays dividends in faster troubleshooting and fewer callbacks. Course descriptions and schedules are in our catalog.

**CALL FOR FREE CATALOG 1-800-644-5544**

Packaged Service Training       Classroom Service Training



