

Bourns® TBU®

High-Speed Protectors

Short Form Brochure

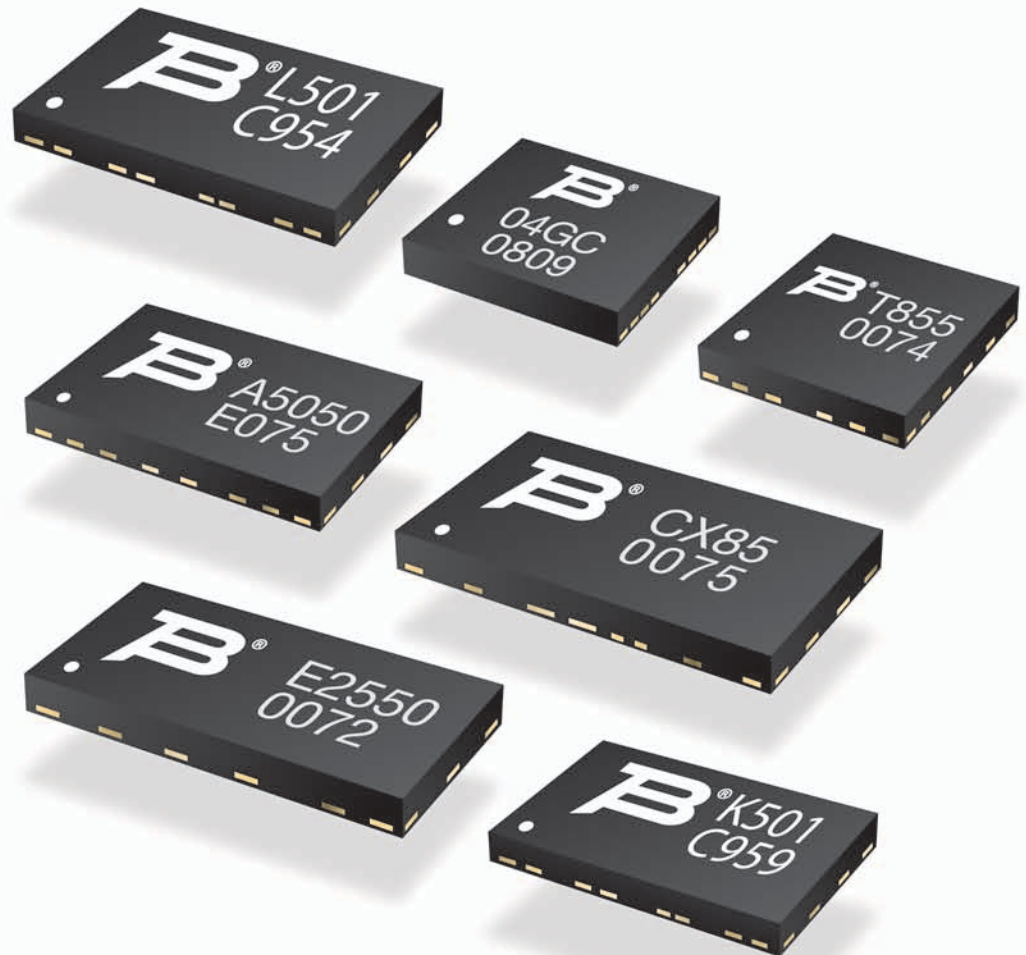

Bourns® TBU® Product Overview

Basic TBU® Device Operation

Bourns® TBU® high-speed protectors are circuit protection devices constructed using MOSFET semiconductor technology. When placed in series in the system, the TBU® protector monitors the current flowing through the line. If the current exceeds a preset level, the TBU® device triggers, providing an effective barrier to large, destructive voltages or currents during surge events, thereby protecting sensitive electronics.

The TBU® device operates in approximately 1 μ s - once line current exceeds the TBU® device's trigger current I_{trigger} . When operated, the TBU® device restricts line current to less than 1 mA typically, and blocks voltages including the surge up to rated limits.

After the surge, the TBU® automatically resets itself when the voltage across the TBU® device falls to the V_{reset} or below. Therefore, the TBU® device will automatically reset on lines which have no DC bias or have DC bias below V_{reset} (such as unpowered signal lines).

If the line has a normal DC bias above V_{reset} , the voltage across the TBU® device may not fall below V_{reset} after the surge. In such cases, special care needs to be taken to ensure that the TBU® device will reset; software monitoring may be used to accomplish this task. Bourns application engineers can provide further assistance.

TBU-based Solution Device Selection

Step 1: Current characterization:

Determine the peak system operating current and maximum operating ambient temperature. Use the TBU® device data sheet's "trigger current versus temperature" derating curve to determine the TBU® device derating value.

Step 2: Overvoltage selection:

Select an overvoltage device that has the lowest available DC breakdown voltage greater than the normal system voltages and any expected AC power faults. The selected device must also be capable of handling the required lightning current.

Step 3: TBU® device selection:

Choose a TBU® device with a maximum impulse voltage (V_{imp}) greater than the maximum impulse breakover or clamping voltage of the selected overvoltage protector. The selected TBU® device must also have a minimum specified I_{trigger} above the maximum peak system operating current compensating for the temperature derating.

Step 4: Tertiary protection:

In most applications, the protected circuit sources sufficient current to trigger the TBU® device. If the protected circuit impedance is high, a small avalanche diode to ground or small signal diodes clamping to the power supply rails may be placed after the TBU® device. This will ensure that the TBU® device triggers, preventing the voltage at the interface from rising to unsafe levels.

Key Features:

- TBU® device is used in series with the line
- TBU® device is triggered by current rise
- TBU® device can block voltages up to 850 V, enabling easy coordination
- TBU® device provides superior protection in less than 1 μ s
- TBU® device resets on voltage
- TBU® device offers an extremely low capacitance per line

Key Benefits:

- High-speed performance
- Blocks voltages and currents
- Extremely low let-through energy of 100 nJ
- Self-resetting on non-DC biased lines
- Very high bandwidth up to 3 GHz
- Small size in DFN package
- TBU-PL & TBU-PK series offer voltage triggering
- Smallest PCB area
- Ultra low profile

TBU-VI Curve

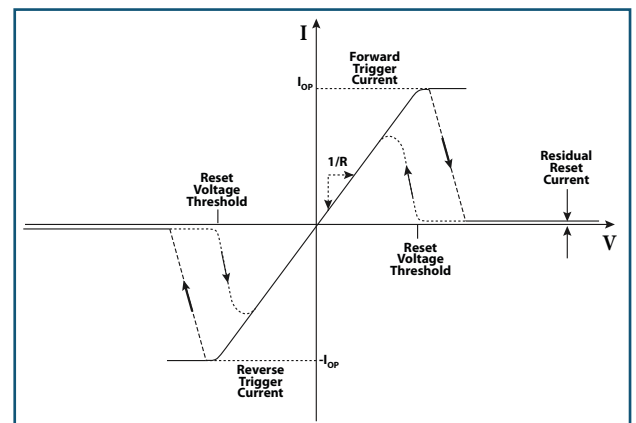

Bourns® TBU® Product Examples

VOICE

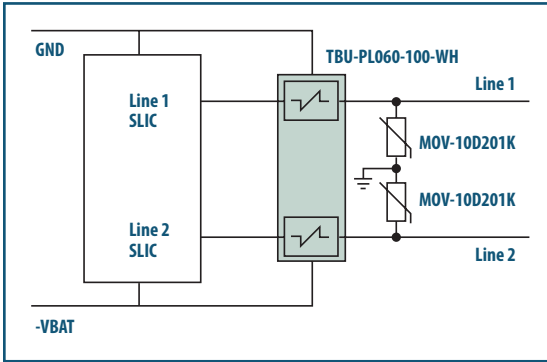

Review VOICE Protection Solution Selection Guide to select TBU® and overvoltage part numbers to meet protection industry standard.

VDSL

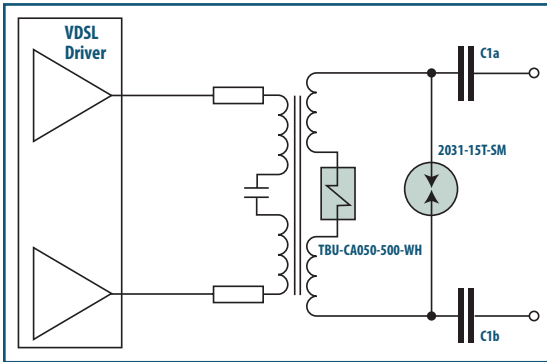

T1/E1 Interface

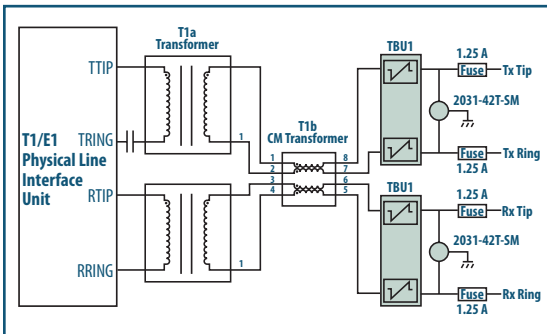

Gigabit Ethernet

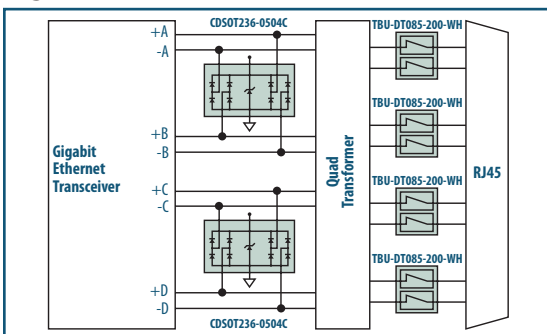

VOICE Protection Solution Selection Guide

Industry Standard	Surge & AC Withstand	Bourns® TBU® Device Selection			
		TBU® Device Part Number	Qty	OVP Device Part Number	Qty
Telcordia GR-1089-CORE Intra-building Port Type 4	1500 V, 100 A 2/10 μ s 120 V _{rms} , 25 A, 900 s	TBU-PL050-100-WH	1	MOV-07D201K	2
Telcordia GR-1089-CORE Intra-building Port Type 4a	1000 V, 100 A 10/1000 μ s 120 V _{rms} , 25 A, 900 s	TBU-PL060-100-WH	1	MOV-10D201K	2
Non-GR-1089-CORE Intra-building Specifications	5000 V, 500 A 2/10 μ s 230 V _{rms} , 25 A, 900 s	TBU-PL085-100-WH	1	MOV-10D361K	2
	1500 V, 100 A 2/10 μ s 275 V _{rms} , 25 A, 900 s	TBU-PL085-100-WH	1	MOV-10D431K	2
ITU-T Basic K.20, K.21, K.45	4000 V, 40 Ω 10/700 μ s 230 V _{rms} 10 Ω - 1000 Ω , 900 s 600 V _{rms} 600 Ω , 0.2 s	TBU-PL075-100-WH	1	MOV-10D361K	2
	4000 V, 40 Ω 10/700 μ s 230 V _{rms} 10 Ω - 1000 Ω , 900 s 600 V _{rms} 600 Ω , 0.1 s	TBU-PL060-100-WH	1	TISP4400M3BJ	2
ITU-T Enhanced K.20, K.21, K.45	6000 V, 40 Ω 10/700 μ s 240 V _{rms} 10 Ω - 1000 Ω , 900 s 600 V _{rms} 600 Ω , 0.2 s 600 V _{rms} 600 Ω , 1 s* 1500 V _{rms} , 200 Ω , 2 s*	TBU-PL085-100-WH	1	MOV-10D391K	2
	6000 V, 40 Ω 10/700 μ s 240 V _{rms} 10 Ω - 1000 Ω , 900 s 600 V _{rms} 600 Ω , 1 s 1500 V _{rms} , 200 Ω , 2 s	TBU-PL060-100-WH	1	TISP4500H3BJ	2

* GDT Special Test Protector with DC breakdown (DCBD) of less than 330 V.

Notes:

- The Le9500, Le9520 and Le9530 (VE950 series) require a 200 mA I_{trigger} TBU® device for normal operation. Other SLIC types should use the 100 mA device.
- The MOV maximum continuous rms voltage rating should not be exceeded. The exception is where the data sheet highlights withstand capability such as the 600 V rms, 1 A for 0.2 s, for example.
- If EN55024 EMC compliance is required, the TBU® device may require capacitors to be fitted between the Tip and Ring connections and ground (i.e. in parallel with the MOV device). The capacitance value can be chosen to meet levels as follows:
 - 10 nF for EN55024 Level 1
 - 20 nF for EN55024 Level 2
 - 47 nF for EN55024 Level 3

Selection of capacitor voltage rating depends upon TBU® part number selection. Recommendations include:

- TBU-PL050 & TBU-PL060 Series: 120 VAC, 500 V Peak Surge Rated
- TBU-PL075 & TBU-PL085 Series: 240 VAC, 750 V Peak Surge Rated

Depending upon the SLIC type, it is usually possible to remove any EMI capacitors present between the output of the SLIC and ground when using capacitors C1 and C2 in parallel with the MOVs.

Bourns® TBU® Product Examples

RS232 Interface

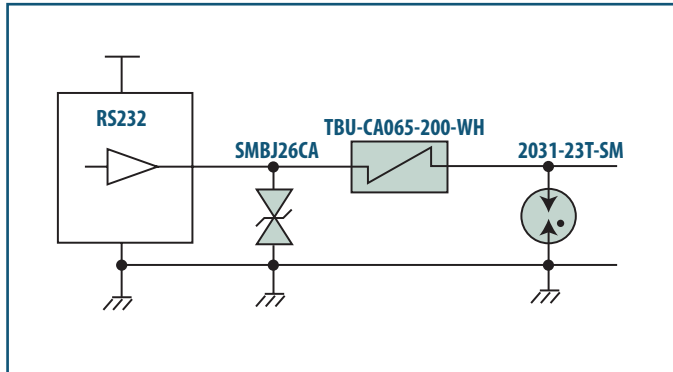

RS485 Interface

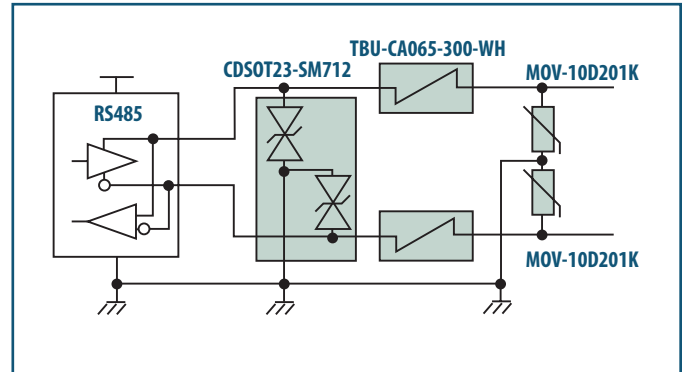

RS422 Interface

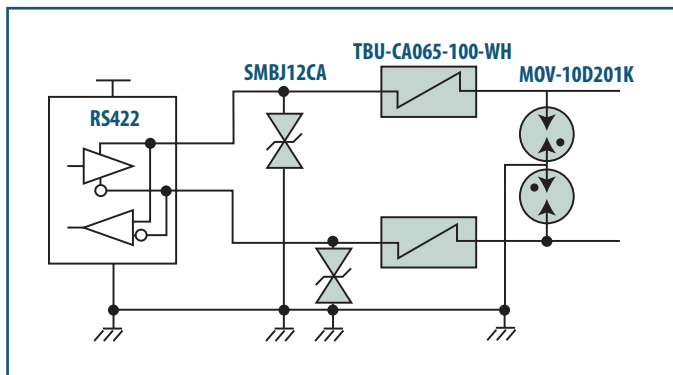

CANBUS

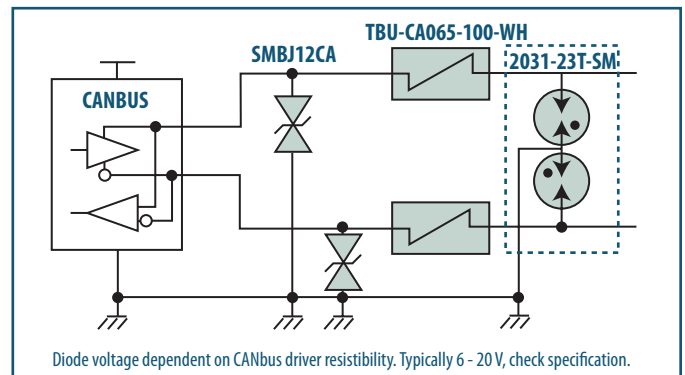

Intelligent Transport System

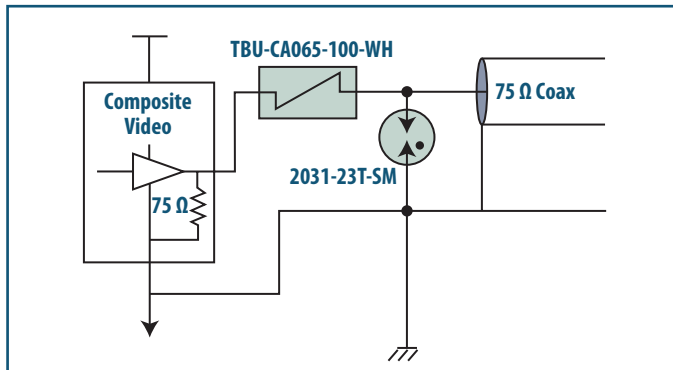

Intrinsically Safe Sensor

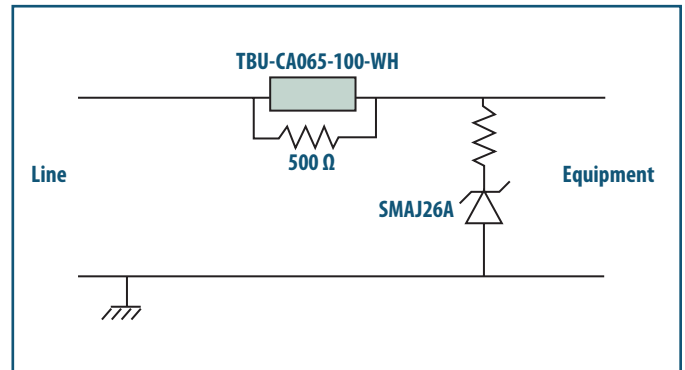

Microwave Link

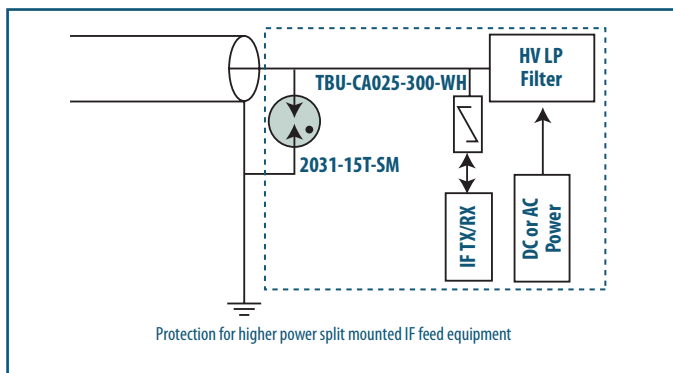

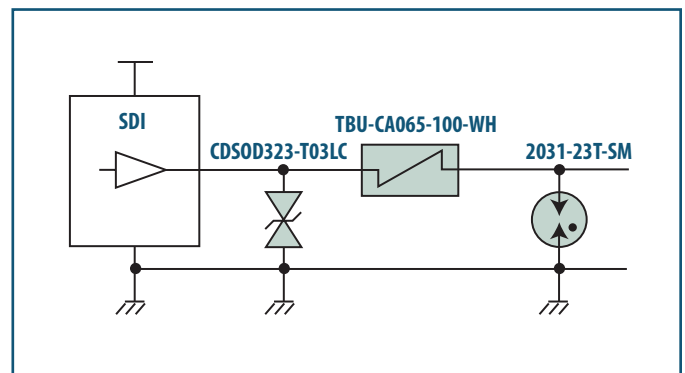

Video Surveillance



Bidirectional Dual TBU® Protectors

TBU-PL, TBU-PK & P40 Product Families

Part Number	Maximum Ratings		Operating Characteristics				Device Size (mm)	Form Factor
	V_{imp} (V)	V_{rms} (V)	$I_{trigger}$ Min. (mA)	$I_{trigger}$ Max. (mA)	t_{block} (μ s)	R_{typ} (Ω)		
P40-G240-WH	40	28	240	480	0.2	3.6	4.00 x 4.00	
TBU-PL050-100-WH	500	300	100	200	1	50	6.50 x 4.00	
TBU-PL050-200-WH	500	300	200	400	1	50		
TBU-PL060-100-WH	600	350	100	200	1	50		
TBU-PL060-200-WH	600	350	200	400	1	50		
TBU-PL075-100-WH	750	400	100	200	1	50		
TBU-PL075-200-WH	750	400	200	400	1	50		
TBU-PL085-100-WH	850	425	100	200	1	50		
TBU-PL085-200-WH	850	425	200	400	1	50	6.50 x 4.00	
TBU-PK050-100-WH	500	300	100	200	1	80		
TBU-PK060-100-WH	600	425	100	200	1	80		
TBU-PK085-100-WH	850	425	100	200	1	80		

V_{imp} — Maximum peak impulse voltage withstand with duration less than 10 ms.

V_{rms} — Maximum continuous alternating current RMS voltage.

$I_{trigger}$ — Minimum and maximum current required for the device to go from operating state to protected state.

t_{block} — Maximum time for the device to go from normal operating state to protected state.

R_{typ} — Typical series resistance of the TBU® device.

Consult factory for alternate specification values. See data sheet for detailed specifications.

TBU® Lightning Surge Protection

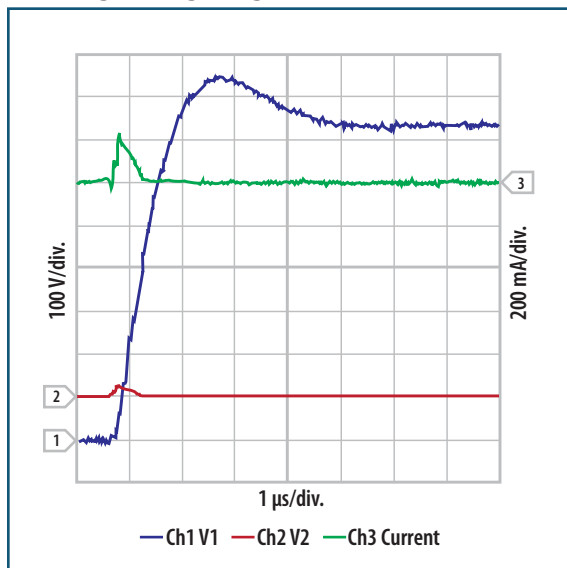

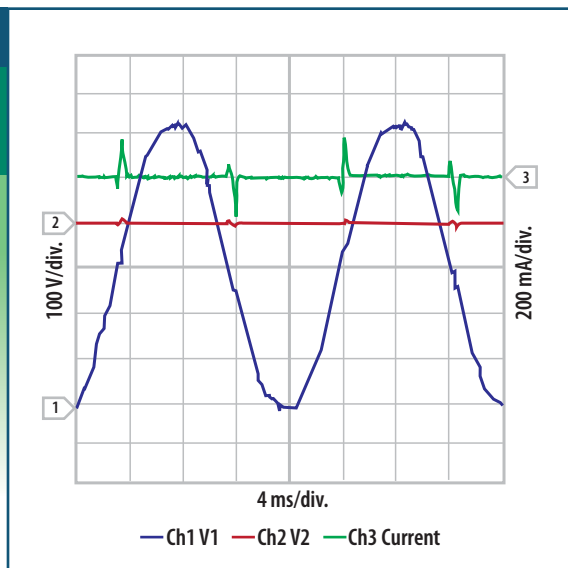

TBU® Power Fault Protection



Bidirectional Single TBU® Protectors

TBU-CA & TBU-CX Product Families

Part Number	Maximum Ratings		Operating Characteristics				Device Size (mm)	Form Factor
	V _{imp} (V)	V _{rms} (V)	I _{trigger} Min. (mA)	I _{trigger} Max. (mA)	t _{block} (μs)	R _{typ} (Ω)		
TBU-CA025-050-WH	250	100	50	100	1	13.3	6.50 x 4.00	
TBU-CA025-100-WH	250	100	100	200	1	7.1		
TBU-CA025-200-WH	250	100	200	400	1	4.2		
TBU-CA025-300-WH	250	100	300	600	1	3.2		
TBU-CA025-500-WH	250	100	500	1000	1	2.6		
TBU-CA040-050-WH	400	200	50	100	1	14.3		
TBU-CA040-100-WH	400	200	100	200	1	8.1		
TBU-CA040-200-WH	400	200	200	400	1	5.2		
TBU-CA040-300-WH	400	200	300	600	1	4.3		
TBU-CA040-500-WH	400	200	500	1000	1	3.6		
TBU-CA050-050-WH	500	250	50	100	1	15.7		
TBU-CA050-100-WH	500	250	100	200	1	9.5		
TBU-CA050-200-WH	500	250	200	400	1	6.6		
TBU-CA050-300-WH	500	250	300	600	1	5.6		
TBU-CA050-500-WH	500	250	500	1000	1	5.0		
TBU-CA065-050-WH	650	300	50	100	1	17.7		
TBU-CA065-100-WH	650	300	100	200	1	11.5		
TBU-CA065-200-WH	650	300	200	400	1	8.6		
TBU-CA065-300-WH	650	300	300	600	1	7.6		
TBU-CA065-500-WH	650	300	500	1000	1	7.0		
TBU-CA085-050-WH	850	425	50	100	1	21.4		
TBU-CA085-100-WH	850	425	100	200	1	15.2		
TBU-CA085-200-WH	850	425	200	400	1	12.3		
TBU-CA085-300-WH	850	425	300	600	1	11.3		
TBU-CA085-500-WH	850	425	500	1000	1	10.7		
TBU-CX025-VTC-WH	250	100	500	1000	1	2.6	8.25 x 4.00	
TBU-CX040-VTC-WH	400	200	500	1000	1	3.6		
TBU-CX050-VTC-WH	500	250	500	1000	1	5.0		
TBU-CX065-VTC-WH	650	300	500	1000	1	7.0		
TBU-CX085-VTC-WH	850	425	500	1000	1	10.7		

Unidirectional Single TBU® Protectors

TBU-KE Product Family

Part Number	Maximum Ratings		Operating Characteristics				Device Size (mm)	Form Factor
	V _{imp} (V)	V _{rms} (V)	I _{trigger} Min. (mA)	I _{trigger} Max. (mA)	t _{block} (μs)	R _{typ} (Ω)		
TBU-KE025-050-WH	250	100	50	100	1	12.5	5.00 x 2.50	
TBU-KE025-100-WH	250	100	100	200	1	6.3		
TBU-KE025-200-WH	250	100	200	400	1	3.4		
TBU-KE025-300-WH	250	100	300	600	1	2.4		
TBU-KE025-500-WH	250	100	500	1000	1	1.8		
TBU-KE040-050-WH	400	200	50	100	1	13.0		
TBU-KE040-100-WH	400	200	100	200	1	6.8		
TBU-KE040-200-WH	400	200	200	400	1	3.9		
TBU-KE040-300-WH	400	200	300	600	1	3.0		
TBU-KE040-500-WH	400	200	500	1000	1	2.3		
TBU-KE050-050-WH	500	250	50	100	1	13.7		
TBU-KE050-100-WH	500	250	100	200	1	7.5		
TBU-KE050-200-WH	500	250	200	400	1	4.6		
TBU-KE050-300-WH	500	250	300	600	1	3.6		
TBU-KE050-500-WH	500	250	500	1000	1	3.0		

Unidirectional Dual TBU® Protectors

TBU-DT Product Family

Part Number	Maximum Ratings		Operating Characteristics				Device Size (mm)	Form Factor
	V _{imp} (V)	V _{rms} (V)	I _{trigger} Min. (mA)	I _{trigger} Max. (mA)	t _{block} (μs)	R _{typ} (Ω)		
TBU-DT065-100-WH	650	300	100	200	1	8.5	5.00 x 5.00	
TBU-DT065-200-WH	650	300	200	400	1	5.6		
TBU-DT065-300-WH	650	300	300	600	1	4.6		
TBU-DT065-500-WH	650	300	500	1000	1	4.0		
TBU-DT085-100-WH	850	425	100	200	1	10.3		
TBU-DT085-200-WH	850	425	200	400	1	7.4		
TBU-DT085-300-WH	850	425	300	600	1	6.8		
TBU-DT085-500-WH	850	425	500	1000	1	5.8		

Worldwide Sales Offices

Country	Phone	Fax
Americas:	+1-951-781-5500	+1-951-781-5006
Brazil:	+55 11 5505 0601	+55 11 5505 4370
China:	+86 21 64821250	+86 21 64821249
Europe:	+41 (0)41 768 5555	+41 (0)41 768 5510
Japan:	+81 49 269 3204	+81 49 269 3297
Singapore:	+65 6348 7227	+65 6348 1272
Taiwan:	+886 2 25624117	+886 2 25624116
Other Asia-Pacific Countries:	+886 2 25624117	+886 2 25624116

Technical Assistance

Region	Phone	Fax
Asia-Pacific:	+886 2 25624117	+886 2 25624116
Europe, Middle East, Africa:	+41 (0)41 768 5555	+41 (0)41 768 5510
Americas:	+1-951-781-5500	+1-951-781-5700

www.bourns.com

Bourns® products are available through an extensive network of manufacturer's representatives, agents and distributors. To obtain technical applications assistance, a quotation, or to place an order, contact a Bourns representative in your area.

Specifications subject to change without notice. Actual performance in specific customer applications may differ due to the influence of other variables. Customers should verify actual device performance in their specific applications.

BOURNS®

"TBU" is a registered trademark of Bourns, Inc. in the U.S., Taiwan and European Community.

"Bourns" is a registered trademark of Bourns, Inc. in the U.S. and other countries.

COPYRIGHT© 2011, BOURNS, INC. • XX • 6/11 • e/FU1114