

PS-7 portion scale
with extended tray
shown below
on pages 8-9.



DETECTO[®]

A Division of Cardinal Scale Manufacturing Co.



Food Service Catalog



www.Detecto.com

Price Computing Scales	4
Top Loading Dial Scales	6
Portion Scale Accessories	8
Digital Portion Control Scales	9
Ingredient and POS Scales	10
Baker Dough Scales	11
Hanging Digital and Dial Scales	12
Hanging Dial Scales	13
Nautilus Washdown Bench Scales	14
Splashproof Bench Scales	15
Digital Receiving Scales	16
Mechanical Receiving Scales	18
Heavy-Duty Receiving Scales	20
Step-On Cans	21
Universal Glove Box Holders	22
Index	23



CORPORATE HEADQUARTER CONTACTS:

Address: 203 East Daugherty Street, Webb City, MO 64870 USA

Fax: (417) 673-5001

Web Site: www.Detecto.com

Customer Service 8 am - 5 pm CST Mon. - Fri.
 (800) 641-2008
 detecto@cardet.com

Technical Support 8 am - 5 pm CST Mon. - Fri.
 (866) 254-8261
 service@cardet.com

Parts Department 8 am - 5 pm CST Mon. - Fri.
 (800) 641-2045
 parts@cardet.com

Quality Assurance 8 am - 5 pm CST Mon. - Fri.
 (417) 673-4631
 qa@cardet.com

INTERNATIONAL CONTACTS:

European Warehouse
 Unit 17/18 Mercers Road
 Chapel Pond Hill
 Bury St. Edmunds, Suffolk, IP32 7HX
 Phone: 44-1284-703117
 Fax: 44-1284-703559
 E-mail: sales@detectoscale.co.uk

Canadian Warehouse
 1815 Ironstone Manor
 Unit 14A
 Pickering, Ontario L1W 3W9
 Phone: (905) 839-6239
 Fax: (905) 839-6522
 E-mail: canada@cardet.com



Products bearing this symbol require some assembly and setup that is not included in purchase price. Contact your local DETECTO scale technician for this service.



Products bearing this symbol are manufactured in compliance with recommendations set forth in Handbook 44, issued by the National Institute of Standards and Technology and have been issued a Certificate of Conformance under the National Type Evaluation Program.



Products bearing this symbol meet or exceed the applicable National Sanitation Foundation requirements for equipment used in processing food.



Products bearing this symbol have been evaluated and found to conform with the appropriate requirements and issued a Notice of Approval by Measurement Canada, an agency of Industry Canada.

DETECTO

DETECTO is pleased you have chosen this catalog to view our comprehensive line of food service products. Our manufacturing plant and corporate offices are positioned in the heartland of America, Webb City, Missouri. As a USA manufacturer, **DETECTO** takes pride in providing centralized customer service and technical support when you require it most.

Specializing in retail food applications, **DETECTO** provides you with a choice of scales to meet your specific application. Our wide range of "Legal for Trade" scales allow you to choose the product best suited for your business. Whether you require Price Computing Scales with retail labeling or robust Receiving Scales to weigh incoming goods, you will find the scale that is designed to provide years of service for your business in this catalog. **DETECTO** can even provide wash-down scales to handle the harshest of environments to keep you weighing at all times.

The restaurant and food industry requires a large selection of scales for weighing portions and ingredients for the preparation of foods. Whether you need digital portioning scales with multiple weight units or top loading dial scales for fast and easy weighing, **DETECTO** will assist you with the correct scale for your weighing needs. For specialized industry needs, **DETECTO** has Digital Pizza Scales for building complete pizzas by weight that are easy to use and insure continuity in your product. For baking applications, **DETECTO**'s Baker Dough Scales are the ideal choice for those looking for the best method of accurate ingredient weighing. Many applications require battery operation when electricity is not readily available. The DS series Price Computing Scales and PS Series Digital Portion Scales are an excellent choice for portable weighing with rechargeable battery operation.

We thank you for your continuing support of **DETECTO** and encourage you to view our comprehensive product catalog. For over 100 years, **DETECTO** has been "*building a better weigh*" for our customers.



(pictured left to right) President David Perry,
Director Rebecca Perry, and Director Bill Perry III



Cert. No.
88-028A4

DETECTO'S MOST VERSATILE PRICE COMPUTING SCALE

Whether you require basic price-per-pound calculations or complete product labeling, the PC series will fill your needs. The 54 possible, easy-to-use PLU (Price Look Up) keys provide instant recall of product prices for speedy calculation of total price and allow fast output to a printer.

FEATURING:

- Easy-to-use price per pound feature with instant display of total price.
- Up to 99 product prices can be stored in memory for speedy recall along with product names when the optional label printer is used.
- Assign shelf life for each product, providing "Packed On" and "Sell By" dates printed on the thermal label.

PC Series Price Computing Scales

The PC Series features an alpha keypad to name each product for printing on the labels and is constructed of heavy steel guaranteeing top performance in the harshest environments.

The stainless steel commodity tray is simple to remove and clean. The bright red LED display is readily viewable by the operator and customer on both sides of the



scale. Whether you require a basic price computing scale or the added power of labeling, Detecto's PC Series scales can handle the task.

MODEL	CAPACITY	UPC CODE
PC-10	6 lb x 0.002 lb	809161100105
PC-10KG	3 kg x 0.001 kg	809161126709
PC-20	15 lb x 0.005 lb	809161100204
PC-20KG	6 kg x 0.002 kg	809161126808
PC-30	30 lb x 0.01 lb	809161100303
PC-30KG	15 kg x 0.005 kg	809161126907
6100-0001	Confectionery Scoop	809161100402

Display: 16 character .56" (14mm) high red LED front and rear
Weight: 5 digits

Unit Weight: 5 digits

Total Price: 6 digits

Notice of Approval
AM-4539 Rev. 2



Shipping Weight: 21 lb / 9.5 kg

Power Source: 115 VAC, 50/60 Hz (Optional 230 VAC, 50/60 Hz); powering a 12 VDC, 700 mA wall-plug-in power module

Platform Size: 13.5" W x 8.75" D / 34 cm W x 22 mm D

Overall Size: 13.5" W x 12" D x 4.25" H / 34 cm W x 31 cm D x 11 cm H



54 Possible Preset Keys

Simply place a product on the scale and press the product's pre-defined preset key to access stored data.



Ground Chuck	Round Steak	Pork Steak
T-Bone	8 oz Filet	Pork Chops
Choice Sirloin	12 oz Filet	Bacon

PRICE LOOK UP PRESET KEYS

Removable PLU key label chart for identifying your specific products on the keyboard.

Price Computing Label Printer

The PC Series features serial output for connectivity to a label printer. Take the guesswork out of pricing your products by utilizing the optional P220 thermal label printer.

MODEL	DESCRIPTION	UPC CODE
P220	Thermal Printer	809161100709
6600-0220	735 labels for P220 2.25" x 2.00"	809161100907

Overall Size: 3.6" W x 7.5" D x 6.8" H / 9 cm W x 19 cm D x 17 cm H

Shipping Weight: 2.7 lb / 1.2 kg

The labels clearly show:

- Your store name
- Product names
- "Packed On" and "Sell By" dates
- Unit price per pound or by each
- Large print of total price
- Bar code printing





Cert. No.
04-085



Take the guess work out of pricing with Detecto's DS series price computing scales. Designed for portable use with a built-in rechargeable battery pack, the DS series is ideal for deli's, bakeries, candy and coffee shops, convenience stores, produce markets, hardware stores and more.

FEATURING:

- Rechargeable battery pack and AC power cord
- Sleep mode for extended battery life
- Dust/debris cover for extended protection
- Easy-to-read, backlit LCD display
- Easy-to-clean, removable stainless steel platter

SIMPLE AND ECONOMICAL, YET TOUGH AND PORTABLE

DS Series Price Computing Scales

The built-in rechargeable battery supply not only monitors the battery life, but also recharges the battery while the scale is in operation ensuring no unexpected "down time". Pressing the PrePack key after the unit price has been entered, retains that price for repetitive price-computing making the operator's job even more simple.

Adjustable, nonskid feet and internal bubble level ensure steady weighing. The smooth lines of the molded poly enclosure, lift-off stainless steel commodity tray and sealed membrane keypad make cleaning an easy chore. These digital price computing scales include a standard 3 prong AC cord - no large AC adapter to take up valuable wall space. All models display weight, unit price and total price simultaneously.

MODEL	CAPACITY	UPC CODE
DS-6	6 lb x 0.002 lb / 3 kg x 0.001 kg	809161132601
DS-12	12 lb x 0.005 lb / 6 kg x 0.002 kg	809161132700
DS-30	30 lb x 0.01 lb / 15 kg x 0.005 kg	809161132809
DS-60	60 lb x 0.02 lb / 30 kg x 0.01 kg	809161132908
6100-0001	Confectionery Scoop	809161100402

Display: 0.75" high backlit LCD
 Weight: 5 digits
 Unit Weight: 5 digits
 Total Price: 6 digits

Shipping Weight: 13 lb / 6 kg
Platform Size: 11.38" W x 8.25" D / 29 cm x 21 cm
Overall Size: 11.75" W x 12.63" D x 4.25" H / 30 cm W x 32 cm D x 11 cm H
Power Source: Rechargeable battery pack or 115 VAC 50/60Hz or 230 VAC 50/60Hz



CUSTOMER DISPLAY



OPERATOR DISPLAY



The liquid crystal display is backlit to provide easy viewing of weight, unit price and total price. The color-coded keypad insures simple and accurate operation.

For added protection, the "legal-for-trade" DS series includes a dust/debris cover and a water well under the platter to further protect against moisture and accidental spills.



Petite Top Loading Dial Scales

MODEL	CAPACITY	DIAL	FINISH	UPC CODE
PT-1	16 oz x 1/4 oz	Fixed	Enamel	809161104608
PT-2	32 oz x 1/4 oz	Fixed	Enamel	809161104707
PT-5	5 lb x 1/2 oz	Fixed	Enamel	809161104806
PT-25	25 lb x 1/8 lb	Fixed	Enamel	809161104905
PT-2R	32 oz x 1/4 oz	Rotating	Enamel	809161105001
PT-2SR	32 oz x 1/4 oz	Rotating	Stainless Steel	809161105100
PT-5R	5 lb x 1/2 oz	Rotating	Enamel	809161105209
PT-5SR	5 lb x 1/2 oz	Rotating	Stainless Steel	809161122503
PT-10SR	10 lb x 1 oz	Rotating	Stainless Steel	809161122602
PT-25-R	25 lb x 1/8 lb	Rotating	Enamel	809161105308
PT-25SR	25 lb x 1/8 lb	Rotating	Stainless Steel	809161122701
PT-500RK	500 g x 2 g	Rotating	Enamel	809161105407
PT-500SRK	500 g x 2 g	Rotating	Stainless Steel	809161105506
PT-1000RK	1,000 g x 5 g	Rotating	Enamel	809161105605
PT-1000SRK	1,000 g x 5 g	Rotating	Stainless Steel	809161105704

Platform Size: 5.75" (15 cm) square. PT-25: 7.9"W x 5.9"D / 20 cm W x 15 cm D

Overall Size: 6.125"W x 7.25"D x 7.25"H / 16 cm W x 18 cm D x 18 cm H

Dial Size: 6" / 15 cm diameter

Shipping Weight: 5 lb / 2 kg

Taco/French Fry Dial Scale

Snap-on stainless steel tray for tacos and french fries

MODEL	CAPACITY	DIAL	FINISH	UPC CODE
PT-1TF	16 oz x 1/4 oz	Fixed	Enamel	809161105803

Overall Size: 5.25"W x 7.25"D x 7.5"H / 13 cm W x 18 cm D x 19 cm H

Dial Size: 6" / 15 cm diameter

Shipping Weight: 6 lb / 2.3 kg

Ice Cream Overrun Dial Scale

Pint measuring cup included - Dial chart designed to give overrun percentages

MODEL	CAPACITY	DIAL	FINISH	UPC CODE
PT-2C	32 oz x 1/4 oz	Fixed	Enamel	809161105902

Overall Size: 5.25"W x 7.25"D x 7.5"H / 13 cm W x 18 cm D x 19 cm H

Dial Size: 6" / 15 cm diameter

Shipping Weight: 6 lb / 2.3 kg

Dual Reading Metric Dial Scales * denotes models equipped with air dashpot

MODEL	CAPACITY	DIAL	FINISH	UPC CODE
T1KP	1 kg x 5 g / 2.2 lb x 1/8 oz	Fixed	Enamel	809161121308
T2KP	2 kg x 10 g / 4.3 lb x 1/2 oz	Fixed	Enamel	809161108705
T5KP	5 kg x 25 g / 11 lb x 1 oz	Fixed	Enamel	809161108804
T10KP	10 kg x 50 g / 22 lb x 1 oz	Fixed	Enamel	809161108903
T25KP	25 kg x 100 g / 55 lb x 2 oz	Fixed	Enamel	809161109009
T1KPD*	1 kg x 5 g / 2.2 lb x 1/8 oz	Fixed	Enamel	809161121407
T2KPD*	2 kg x 10 g / 4.3 lb x 1/2 oz	Fixed	Enamel	809161109108

Platform Size: 9"W x 9"D / 23 cm W x 23 cm D stainless steel

Overall Size: 8.5"W x 10.25"D x 10.5"H / 22 cm W x 26 cm D x 27 cm H

Dial Size: 8" / 20 cm diameter

Shipping Weight: 8 lb / 4 kg



Model PT5R



Model PT25SR



Model T25KP

Large Dial Scales

* denotes models equipped with air dashpot

MODEL	CAPACITY	DIAL	FINISH	UPC CODE
T2	32 oz x 1/8 oz	Fixed	Enamel	809161107104
T2R	32 oz x 1/8 oz	Rotating	Enamel	809161107302
T2RD*	32 oz x 1/8 oz	Rotating	Enamel	809161107401
T-2-S	32 oz x 1/8 oz	Fixed	Stainless Steel	809161107500
T-2-SD*	32 oz x 1/8 oz	Fixed	Stainless Steel	809161107609
T5	5 lb x 1/2 oz	Fixed	Enamel	809161107708
T-5-S	5 lb x 1/2 oz	Fixed	Stainless Steel	809161122206
T10	10 lb x 1 oz	Fixed	Enamel	809161107906
T-10-S	10 lb x 1 oz	Fixed	Stainless Steel	809161122305
T25	25 lb x 1 oz	Fixed	Enamel	809161108101
T-25-S	25 lb x 1 oz	Fixed	Stainless Steel	809161122404
T50	50 lb x 2 oz	Fixed	Enamel	809161108309

Platform Size: 9"W x 9"D / 23 cm W x 23 cm D stainless steel
Overall Size: 8.5"W x 10.25"D x 10.5"H / 22 cm W x 26 cm D x 27 cm H
Dial Size: 8" / 20 cm diameter **Shipping Weight:** 8 lb / 4 kg

MODEL	CAPACITY	DIAL	FINISH	UPC CODE
T100	100 lb x 4 oz	Fixed	Enamel	809161108408

Platform Size: 11.5"W x 11.5"D / 29 cm W x 29 cm D chrome-plated steel
Overall Size: 10"W x 14.75"D x 14.5"H / 25 cm W x 37 cm D x 37 cm H
Dial Size: 10.5" / 27 cm diameter **Shipping Weight:** 20 lb / 9 kg

MODEL	CAPACITY	DIAL	FINISH	UPC CODE
T200	200 lb x 8 oz	Fixed	Enamel	809161108507

Platform Size: 15"W x 15"D / 38 cm W x 38 cm D chrome-plated steel
Overall Size: 10"W x 14.75"D x 14.5"H / 25 cm W x 37 cm D x 37 cm H
Dial Size: 10.5" / 27 cm diameter **Shipping Weight:** 24 lb / 11 kg

Large-Capacity Dual Reading Metric Dial Scales

MODEL	CAPACITY	DIAL	FINISH	UPC CODE
T50KP	50 kg x 200 g / 110 lb x 1/4 lb	Fixed	Enamel	809161121506

Platform Size: 13"W x 13"D / 33 cm W x 33 cm D stainless steel
Overall Size: 14"W x 15.75"D x 15.5"H / 36 cm W x 40 cm D x 39 cm H
Dial Size: 10.5" / 27 cm diameter **Shipping Weight:** 26 lb / 12 kg

Top Loading Dial Scales With Bowl

MODEL	CAPACITY	DIAL	FINISH	UPC CODE
T10KPB	10 kg x 50 g / 22 lb x 1 oz	Fixed	Enamel	809161133301
T25KPB	25 kg x 100 g / 55 lb x 2 oz	Fixed	Enamel	809161121902
T25B	25 lb x 1 oz	Fixed	Enamel	809161133400
T50B	50 lb x 2 oz	Fixed	Enamel	809161108606
T25SB	25 lb x 1 oz	Fixed	Stainless Steel	809161133509

Platform: Special stainless steel platform with folded edges allows easy removal and/or replacement of the bowl
Bowl Size: 4" H x 11.5" diameter / 10 cm H x 29 cm diameter stainless steel
Overall Size: 8.5"W x 10.25"D x 10.5"H / 22 cm W x 26 cm D x 27 cm H
Dial Size: 8" / 20 cm diameter **Shipping Weight:** 11 lb / 5 kg



Model T2R



Model T25



Model T50B

PORTION SCALE ACCESSORIES



Digital Ice Cream Cone Scales

Detecto's Ice Cream Cone Scale is a 4 lb x 0.1 oz model PS-4 digital scale with two options of ice cream cone holders to choose from listed below. Detecto's cone holder tray is removable, so the scale may be used for weighing cups and other portioning needs. The smooth lines of the scale's molded poly enclosure, lift-off stainless steel tray, and sealed membrane keypad make cleaning the scale easy.



Detecto model PS-4 portion scale (specs on p. 9) shown here with model ICH2 dual ice cream cone holder.

Model ICH1

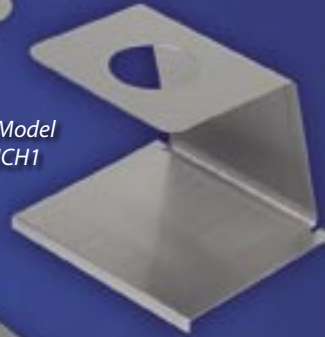

Model ICH2

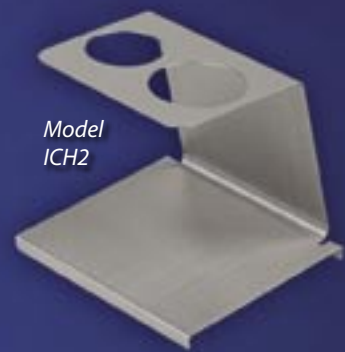

MODEL	CAPACITY	UPC CODE
ICH1	Single Cone Holder (holds 1 cone)	809161180404
ICH2	Dual Cone Holder (holds 2 cones)	809161180503

Construction: Stainless steel

Overall Size: 5.75" W x 4.83" D x 4.82" H / 14 cm W x 12 cm D x 12 cm H

Hole Diameters: ICH1 - 1.875" / 47 mm
ICH2 - 1.5" and 2" / 38 mm and 50 mm



Extended Tray for PS-7 Portion Scale

Ideal for weighing meats, cheeses, and condiments for sandwiches and salads, Detecto's PS-7 portion scale features an optional stainless steel extended tray. The model ET7 extra-large platter measures 9-3/4" wide x 6-3/4" deep and lifts off for easy cleaning.



Detecto model PS-7 with ET7 extended tray.

Model ET7



Model PS7 (specs on p. 9)



MODEL	DESCRIPTION	SHIPPING WT.	UPC CODE
ET7	Extended Tray For Model PS7	1 lb / .45 kg	809161180800

Construction: Stainless steel

Dimensions: 9.75" W x 6.75" D / 25 cm W x 17 cm D



AC or battery power



Digital Portion Control Scales

MODEL	CAPACITY	SHIPPING WEIGHT	UPC CODE
PS-4	4 lb x 0.1 oz / 2,000 g x 1 g	4 lb / 1.8 kg	809161138405

Display: 0.8"/20 mm high LCD
Overall Size: 1.5"H x 5.9"W x 6.7"D/4 cm H x 15 cm W x 17 cm D
Platform Size: 5.9"W x 4.75"D/15 cm W x 12 cm D



AC or battery power

MODEL	CAPACITY	SHIPPING WEIGHT	UPC CODE
PS-5A	70 oz x 0.1 oz / 1,998 g x 2 g	4 lb / 1.8 kg	809161101102

Display: 0.5"/13 mm high LCD
Overall Size: 2.75"H x 7"W x 7"D/7 cm H x 18 cm W x 18 cm D
Platform Size: 6.75"W x 5.25"D/17 cm W x 13 cm D



AC or battery power

MODEL	CAPACITY	SHIPPING WEIGHT	UPC CODE
PS-6A	70 oz x 0.25 oz	4 lb / 1.8 kg	809161101300

Display: 0.5"/13 mm high LCD
Overall Size: 2.75"H x 7"W x 7"D/7 cm H x 18 cm W x 18 cm D
Platform Size: 6.75"W x 5.25"D/17 cm W x 13 cm D



AC power or built-in rechargeable battery



MODEL	CAPACITY	SHIPPING WEIGHT	UPC CODE
PS-7	7 lb x 0.1 oz / 112 oz x 0.1 oz / 112 oz x 1/8 oz / 3000 g x 1 g / 7 lb x 0.005 lb	4 lb / 1.8 kg	809161133608

Features the ability to disable different units of measure.



Display: 5-digit, 0.8" x 0.3" characters with fractions LCD
Overall Size: 2.44"H x 8.03"W x 7.87"D / 6 cm H x 20 cm W x 20 cm D
Platform Size: 8.02"W x 4.96"D / 20 cm W x 13 cm D



AC power or built-in rechargeable battery



MODEL	CAPACITY	SHIPPING WEIGHT	UPC CODE
PS-11	11 lb x 0.1 oz / 176 oz x 0.1 oz / 176 oz x 1/4 oz / 5000 g x 2 g / 11 lb x 0.005 lb	6 lb / 2.7 kg	809161133707

Features the ability to disable different units of measure.



Display: 5-digit, 0.8" x 0.3" characters with fractions LCD
Overall Size: 2.3"H x 7.25"W x 9.5"D / 6 cm H x 18 cm W x 24 cm D
Platform Size: 6.89"W x 6.5"D / 18 cm W x 17 cm D



Notice of Approval
AM-4539 Rev. 2



LEGAL FOR TRADE
Cert. No.
95-087A1

AC power



Optional Commodity Scoop - Model 285R31

MODEL	CAPACITY	SHIPPING WEIGHT	UPC CODE
AP-6	99.95 oz x 0.05 oz	5 lb / 2.3 kg	809161101904
AP-8	7.998 lb x 0.002 lb	5 lb / 2.3 kg	809161102000
AP-10	9.995 lb x 0.005 lb	5 lb / 2.3 kg	809161102109
AP-20	19.99 lb x 0.01 lb	5 lb / 2.3 kg	809161102208
AP-4K	3999 g x 1 g	5 lb / 2.3 kg	809161101805

Display: 0.5"/13 mm high LED
Overall Size: 2.75"H x 7.5"W x 7"D/7 cm H x 19 cm W x 18 cm D
Platform Size: 6.75"W x 5.25"D/17 cm W x 13 cm D





Model
PZ3015

PZ SCALE FEATURES:

- Audible Confirmation Of Zero - Easy to Operate
- Easy-To-Read, Large Backlit LCD Display
- Photo Eye Mechanism For Touchless Zeroing of Weight
- Dual Power Source - Rechargeable Battery Pack And AC Adapter

Detecto's stainless steel PZ3000 features totally touchless zeroing of each ingredient for more sanitary conditions and faster prepping. The scales allow convenient units switching between most used measurements and each measurement can easily be turned off.

This ingredient scale features an AC adapter or battery operation with up to 50 hours of continuous use. Non-skid feet allow it to remain steady on slippery surfaces and optional foot tare and mountable pushbutton switches are available.

MODEL	CAPACITY / DESCRIPTION	PLATTER SIZE	SHIP WEIGHT	UPC CODE
PZ3015	15 lb x 1/8 oz / 240 oz x 0.1 oz / 15 lb x 0.005 lb / 7 kg x 2 g / 7 kg x 0.005 kg	8" W x 8" D x 1.75" H / 20 cm W x 20 cm D x 4.4 cm H	10 lb / 5 kg	809161138900
PZ3015L	15 lb x 1/8 oz / 240 oz x 0.1 oz / 15 lb x 0.005 lb / 7 kg x 2 g / 7 kg x 0.005 kg	12" W x 12" D x 1.75" H / 30 cm W x 30 cm D x 4.4 cm H	18 lb / 8 kg	809161139006
PZ3030	30 lb x 1/4 oz / 480 oz x 0.1 oz / 30 lb x 0.01 lb / 15 kg x 5 g / 30 lb x 0.1 oz / 15 kg x 0.005 kg	12" W x 12" D x 1.75" H / 30 cm W x 30 cm D x 4.4 cm H	18 lb / 8 kg	809161139105
PZ3060	60 lb x 1/4 oz / 60 lb x 0.02 lb / 30 kg x 0.02 kg	14" W x 12" D x 3" H / 36 cm W x 30 cm D x 8 cm H	24 lb / 11 kg	809161139204
PZPB	Mountable Tare Button		2 lb / 1 kg	809161139303
PZFS	Foot Tare Pedal		2 lb / 1 kg	809161139402



Model
AS-330D



LEGAL FOR TRADE

Cert. No.
99-198A1



Model
AS-334D

"Legal-For-Trade" Point-of-Sale Scales

This "legal for trade" economical Intelligent Scale Base has a big weighing capacity (150 lbs), yet is still accurate to one half ounce. The display may be mounted on the stainless steel scale base, wall, or counter. The modular serial port allows the scale to be interfaced with a personal computer. Comes with 6-digit, 0.5"/13 mm) 7-segment LED with 5'/1.5 m cable and mounting bracket, and includes 12'/3.7 m computer interface cable. PC connectivity.

MODEL	CAPACITY	SHIPPING WEIGHT	UPC CODE
AS-330D	150 lb x 0.05 lb or 0-100 lb x 0.5 oz or 100-150 lb x 1 oz or kilograms mode	22 lb / 10 kg	809161116304

Display Dimensions: 4.5" W x 0.875" D x 2.5" H / 11 cm W x 2 cm D x 6 cm H

Platform Dimensions: 12" L x 14" W x 3.5" H / 31 cm L x 36 cm W x 9 cm H

Power: 120 Volt AC adapter with 12 volt DC

MODEL	CAPACITY	SHIPPING WEIGHT	UPC CODE
AS-333D	17.5 lb x 0.005 lb / 7 kg x 0.002 kg	10 lb / 5 kg	809161134308
AS-334D	35 lb x 0.01 lb / 17.5 kg x 0.005 kg	10 lb / 5 kg	809161134407

Display Dimensions: 4.5" W x 0.875" D x 2.5" H / 11 cm W x 2 cm D x 6 cm H

Platform Dimensions: 6" L x 10" W x 2.5" H / 15 cm L x 25 cm W x 6 cm H

Power: 120 Volt AC adapter with 12 volt DC

Baked Enamel Baker Dough Scales

MODEL	CAPACITY	UPC CODE
1001TB	16 lb with scoop Beam grads: 16 oz x 1/4 oz	809161103007
1001TBNS	16 lb without scoop Beam grads: 16 oz x 1/4 oz	809161103106
1001TBKG	8 kg with scoop Beam grads: 500 g x 5 g	809161103205
1001T2B	16 lb with scoop Beam grads: 32 oz x 1/2 oz	809161126402
1001T2BNS	16 lb without scoop Beam grads: 32 oz x 1/2 oz	809161126502
1002TB	8 lb with scoop Beam grads: 16 oz x 1/4 oz	809161103304
1002TBNS	8 lb without scoop Beam grads: 16 oz x 1/4 oz	809161103403
1002TBKG	5 kg with scoop Beam grads: 500 g x 5 g	809161103502

Same platform size, scoop material, and shipping weights as stainless steel models, but with a baked enamel finish.



Model
1001TB



Model
1001TBNS

Stainless Steel Baker Dough Scales

MODEL	CAPACITY	UPC CODE
1051TBS	16 lb with scoop	809161103601
1051TBSKG	8 kg with scoop	809161127003
1052TBS	8 lb with scoop	809161103700
1052TBSKG	5 kg with scoop	809161127102

Includes weights

Finish: Stainless steel base, platter, and poise weight

Platform: 9"/23 cm diameter

Scoop: White plastic

Shipping Weights: 38 lb (17 kg) for 16 lb / 8 kg models
30 lb (14 kg) for 8 lb / 5 kg models



Model
1051TBS

Accessories - Additional Weights

Machined weights flat

MODEL	CAP.	UPC CODE
1WP1-1	1 lb	809161103809
1WP2-1	2 lb	809161103908
1WP4-1	4 lb	809161104004
1WP8-1	8 lb	809161104103
1WK1-1	1 kg	809161121605
1WK2-1	2 kg	809161121704
1WK0500-1	500 g	809161121803



Model 285R31



Model 6100-0001



Model 6100-0002



Model 6100-0003

Accessories - Footed Scoops

MODEL	DESCRIPTION	UPC CODE
285R31	White plastic with spout Size: 12" x 6.5" x 2.5" / 30 cm x 17 cm x 6 cm Base: 4.5"/11 cm dia.	809161102307
6100-0001	White plastic with spout Size: 10" x 2.75" high / 25 cm x 7 cm high Base: 6.25"/16 cm dia.	809161100402
6100-0002	Plastic baker dough scoop Size: 21" x 12" x 5.75" / 53 cm x 30 cm x 15 cm Base: 6.25"/16 cm dia.	809161104400
6100-0003	Stainless steel bowl Size: 6.25" x 2.25" / 16 cm x 6 cm Capacity: 0.75 quart	809161102406

“Legal-For-Trade” Digital Scales

The HSDC is a full-featured, battery-powered hanging scale that incorporates push button tare, sleep mode, and auto shutoff mode to prolong battery life. Its aluminum alloy construction makes it lightweight and easy to use, but tough enough to stand up under conditions required of any portable hanging scale. All models are furnished with a hook.

MODEL	CAPACITY	UPC CODE
HSDC-20	20 lb x 0.01 lb	809161127409
HSDC-40	40 lb x 0.02 lb	809161137101
HSDC-100	99.95 lb x 0.05 lb	809161112108
HSDC-200	200 lb x 0.1 lb	809161112207
HSDC-500	500 lb x 0.2 lb	809161112306
<i>(this model is not “legal-for-trade”)</i>		
HSDC-20KG	20 kg x 0.01 kg	809161112405
HSDC-40KG	40 kg x 0.02 kg	809161127508
HSDC-50KG	50 kg x 0.02 kg	809161112504
HSDC-100KG	99.95 kg x 0.05 kg	809161112603

Display: 1”/25mm high LCD

Dimensions: Overall height (eye to hook) 10.75” / 27 cm
Head - 8.25”W x 5” D x 4.5” H /
21 cm W x 13 cm D x 11 cm H

Power: 6 C size alkaline batteries (not included)

Shipping Weight: 5 lb / 2 kg

“Legal-For-Trade” Dial Scale Fish and Vegetable Pan with Extra-Large Dial

Detecto’s T3530 hanging scale comes with a deep 15” (38cm) round stainless steel pan, making it the perfect scale for fish, vegetable or product markets. Long term accuracy is guaranteed by Detecto’s use of Thermo-lastic springs which are not affected by extreme temperature variations. An air dashpot that absorbs shock created when commodities are placed on the scale protects the mechanism and increases the scale life.

MODEL	CAPACITY	REVS	UPC CODE
T3530	32 lb - 10 lb x 1 oz	3.2	809161111903

Dial: 14.5”/37 cm double dial (readable from both sides), plated sashes and stainless steel bands - white face with black lettering

Shipping Weight: 33 lb / 15 kg

Heavy Duty Dial Scale with Hook

Detecto’s 11S Series aluminum scales are ruggedly built and work in bulk weighing and for multiple purposes. They feature a large, 7”/18 cm aluminum dial with black lettering and durable heavy cast iron protective housing to enclose precision parts from dust.

MODEL	CAPACITY	UPC CODE
11S200H	200 lb x 0.5 lb	809161109504
11S400H	400 lb x 1 lb	809161109603
11S200HKG	100 kg x 500 g	809161109702
11S400HKG	200 kg x 500 g	809161109801

Dial: 7”/18 cm single dial, aluminum face, single revolution

Shipping Weight: 11 lb / 5 kg



Model
HSDC-200



LEGAL FOR TRADE

Cert. No.
03-030



Notice of Approval
Pending

Model
T3530

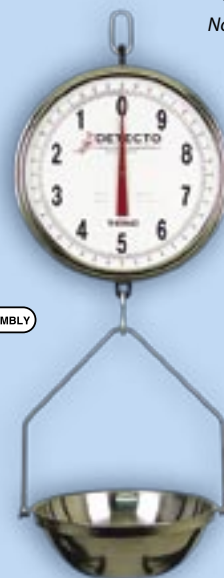

LEGAL FOR TRADE

Cert. No.
88-110

Model
11S400H

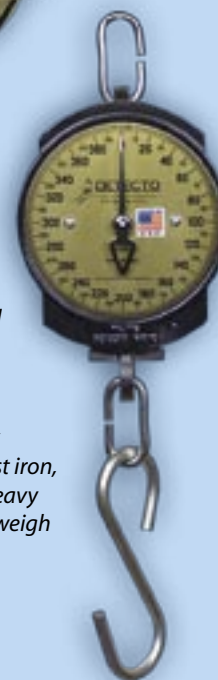

Built for multi-purpose bulk weighings with a heavy, cast iron, protective housing, these heavy duty dial scales accurately weigh large or small quantities.

Utility Scale with "S" Hook

MODEL	CAPACITY	CHART	UPC CODE
MCS-60H	60 lb	(30 lb x 1/10 lb)	809161109900
MCS-60M	60 lb	(30 lb x 1/10 lb)	809161110005

The MCS-60M features an adjustable pointer that can be set anywhere on the dial. The net weight and gross weight are visible in one glance.

Hook: Heavy-duty plated 4"/10 cm S-hook

Dial: 8"/20 cm diameter - 2 revolutions

Shipping Weight: 4 lb / 1.8 kg

Scoop Scale

MODEL	CAPACITY	CHART	UPC CODE
MCS-20P	20 lb	(10 lb x 1 oz)	809161110104
MCS-40P	40 lb	(20 lb x 2 oz)	809161110203
MCS-10KGP	10 kg	(5 kg x 25 g)	809161110302
MCS-20KGP	20 kg	(10 kg x 50 g)	809161110401

Scoop: Galvanized 11" x 16" x 5" / 28 cm x 41 cm x 13 cm with chains

Dial: 8"/20 cm diameter - 2 revolutions

Shipping Weight: 5 lb / 2.3 kg

Fish Scale

MODEL	CAPACITY	CHART	UPC CODE
MCS-20F	20 lb	(10 lb x 1 oz)	809161110500
MCS-40F	40 lb	(20 lb x 2 oz)	809161110609
MCS-10KGF	10 kg	(5 kg x 25 g)	809161110708
MCS-20KGF	20 kg	(10 kg x 50 g)	809161110807

Pan: 14.5"/37 cm round stainless steel pan with drainage holes and stainless steel bow

Dial: 8"/20 cm diameter - 2 revolutions

Shipping Weight: 6 lb / 2.7 kg

Butcher Scale

MODEL	CAPACITY	CHART	UPC CODE
MCS-20B	20 lb	(10 lb x 1 oz)	809161110906
MCS-10KGB	10 kg	(5 kg x 25 g)	809161111002

Plate: 11"/28 cm diameter white enamel, suspended from chrome bow

Dial: 8"/20 cm diameter - 2 revolutions

Shipping Weight: 5 lb / 2.3 kg

Hook Scale

MODEL	CAPACITY	CHART	UPC CODE
MCS-20H	20 lb	(10 lb x 1 oz)	809161111101
MCS-40H	40 lb	(20 lb x 2 oz)	809161111200
MCS-10KGH	10 kg	(5 kg x 25 g)	809161111309
MCS-20KGH	20 kg	(10 kg x 50 g)	809161111408

Hook: Heavy-duty plated 4"/10 cm S-hook

Dial: 8"/20 cm diameter - 2 revolutions

Shipping Weight: 4 lb / 1.8 kg



Model MCS-60H

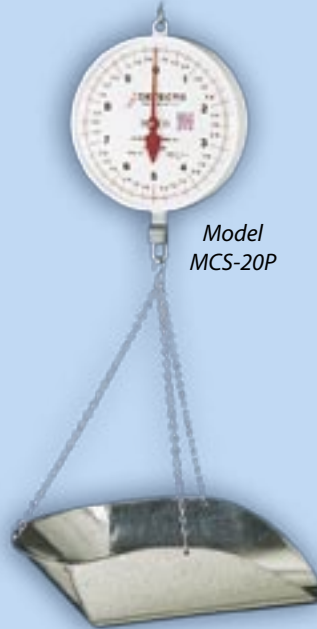

Model MCS-20P



Model MCS-40F

Accessories

"D" Double Dial: available on all scales listed on this page. Add "D" to the model number, for example: MCS-20DF - 20 lb Scoop Scale with double dial.



Model MCS-20B

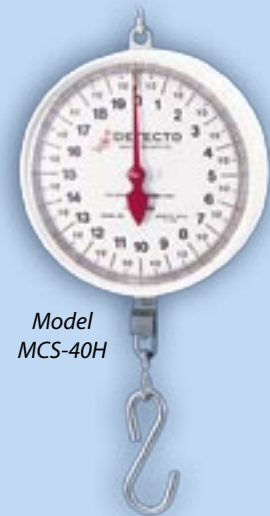

Model MCS-40H

NAUTILUS WASHDOWN BENCH SCALES



Nautilus Bench Scales

Featuring the Model 205 Weight Indicator

MODEL	CAPACITY	UPC CODE
NB1418-60-205	60 lb x 0.02 lb	809161125108
NB1418-125-205	125 lb x 0.05 lb	809161125207
NB1418-30KG-205	30 kg x 0.01 kg	809161125306
NB1418-60KG-205	60 kg x 0.02 kg	809161125405

Featuring the Model 210 Weight Indicator

MODEL	CAPACITY	UPC CODE
NB1418-60-210	60 lb x 0.02 lb	809161125504
NB1418-125-210	125 lb x 0.05 lb	809161125603
NB1418-30KG-210	30 kg x 0.01 kg	809161125702
NB1418-60KG-210	60 kg x 0.02 kg	809161125801

For weight indicator features, please refer to the adjoining page 20.

Overall Dimensions: 15" W x 23.25" D x 27.75" H / 38 cm W x 59 cm D x 70 cm H

Platform Dimensions: 14" W x 18" D / 35 cm W x 45 cm D

Indicator Dimensions:

205: 9" W x 7" H x 2.75" D / 23 cm x 18 cm x 7 cm

210: 9" W x 7" H x 2.75" D / 23 cm x 18 cm x 7 cm

Platform Construction: all-stainless steel with sealed IP68-rated stainless steel load cell

Power: 90 to 260 VAC, 50/60 Hz - 12 VDC

Shipping Weight: 57 lb / 26 kg

Nautilus Stainless Steel Bench Scales

As tough and resilient as their namesake, Detecto's Nautilus Series waterproof bench scales are engineered to provide years of accurate, reliable weighing. The robust parallel flexure weighbridge conforms to Scale Manufacturers Association standards for shock and overload protection.

The Nautilus is constructed entirely of heavy-duty, stainless steel to withstand constant use and frequent wash down with high-pressure hoses. Featuring the model 205 or 210 digital weight indicator with NEMA 4X/IP66 stainless steel enclosure (for additional features, please refer to the adjoining page), the Nautilus works even in the harshest, wettest environments.

Available in four capacities and featuring selectable key lockout, label printing, and adjustable filtering, the Nautilus is the most versatile wash down scale available.

Print tab settings make it easy to setup a ticket or label with information you need to print. Detecto can create two additional custom print formats to meet your specifications, including bar codes!

FEATURES:

- Multiple weight modes, including lb/oz
- All stainless steel construction
- NEMA 4X/IP66 indicator enclosure
- Available in four capacities
- Multiple print formats
- Dual RS232 ports



Cert. No.
02-006



Notice of Approval
AM-5470





LEGAL FOR TRADE

Cert. No.
03-031A1



Notice of Approval
Pending

EB Series Stainless Steel Bench Scales

The EB Bench Scales are designed for top performance and long-term accuracy. For weight indicator differences, please see page 20 for a 200 series weight display breakdown chart.

MODEL	CAPACITY	PLATFORM SIZE	SHIPPING WEIGHT	UPC CODE
EB-15-204			28 lb / 13 kg	809161123609
EB-15-205	15 lb x 0.005 lb /	10" W x 12" D /	30 lb / 14 kg	809161124101
EB-15-210	6 kg x 0.002 kg	25 cm W x 30 cm D	30 lb / 14 kg	809161124606
EB-15-215			30 lb / 14 kg	809161137903
EB-30-204			28 lb / 13 kg	809161123708
EB-30-205	30 lb x 0.01 lb /	10" W x 12" D /	30 lb / 14 kg	809161124200
EB-30-210	15 kg x 0.005 kg	25 cm W x 30 cm D	30 lb / 14 kg	809161124705
EB-30-215			30 lb / 14 kg	809161138009
EB-60-204			43 lb / 20 kg	809161123807
EB-60-205	60 lb x 0.02 lb /	14" W x 16" D /	45 lb / 20 kg	809161124309
EB-60-210	30 kg x 0.01 kg	35 cm W x 40 cm D	45 lb / 20 kg	809161124804
EB-60-215			45 lb / 20 kg	809161138108
EB-150-204			43 lb / 20 kg	809161123906
EB-150-205	150 lb x 0.05 lb /	14" W x 16" D /	45 lb / 20 kg	809161124408
EB-150-210	60 kg x 0.02 kg	35 cm W x 40 cm D	45 lb / 20 kg	809161124903
EB-150-215			45 lb / 20 kg	809161138207
EB-300-204			77 lb / 35 kg	809161124002
EB-300-205	300 lb x 0.1 lb /	20" W x 24" D /	79 lb / 36 kg	809161124507
EB-300-210	150kg x 0.05 kg	50 cm W x 60 cm D	79 lb / 36 kg	809161125009
EB-300-215			79 lb / 36 kg	809161138306



Model
EB-150-205



Model 210

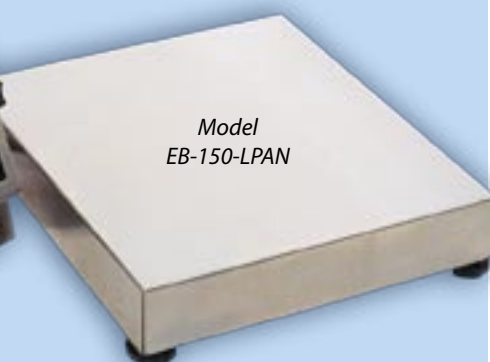

Model
EB-150-LPAN

Indicator Dimensions

- 204:** 8" W x 6.625" H x 2.125" D
(20 cm x 17 cm x 5 cm)
- 205:** 9" W x 7" H x 2.75" D
(23 cm x 18 cm x 7 cm)
- 210:** 9" W x 7" H x 2.75" D
(23 cm x 18 cm x 7 cm)
- 215:** 9" W x 7" H x 2.75" D
(23 cm x 18 cm x 7 cm)

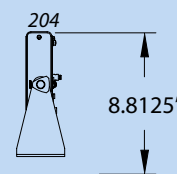
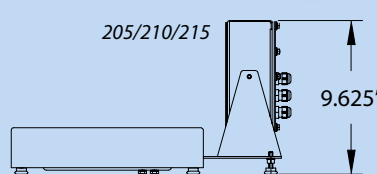
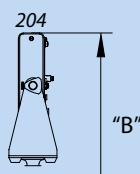
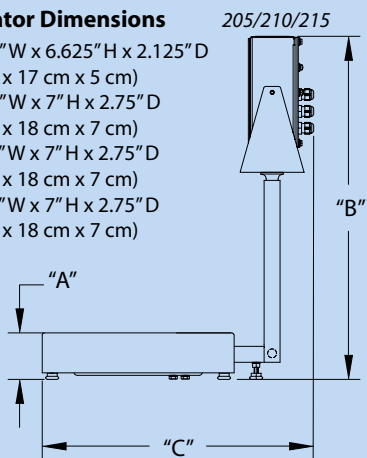

EB DIMENSIONS

MODEL	PLATFORM	INDICATOR	"A"	"B"	"C"
EB-15-	10" x 12"	204	2.9375"	21"	16"
EB-30-	10" x 12"	205/210/215	2.9375"	21.4375"	16.5"
EB-60-	14" x 16"	204	3.1875"	27.875"	20"
EB-150-	14" x 16"	205/210/215	3.1875"	28.0625"	20.5"
EB-300-	20" x 24"	204	5.125"	27.1875"	27"
	20" x 24"	205/210/215	5.125"	27.625"	27.5"



Model
DR550

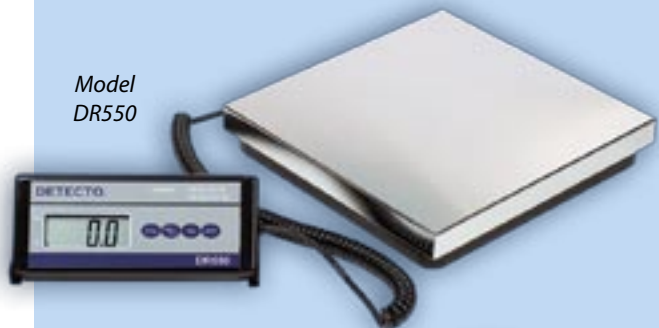

Optional black carrying case with handle protects the scale for easy transport.



Model
DR400



Model
CS-30

The liquid crystal display is backlit to provide easy viewing of weight, average piece weight, and count. The color-coded keypad insures simple and accurate operation.

DR Series Low-Profile Platform Scales

Accurate and reliable, Detecto's economical general purpose DR series platform scales quickly pay for themselves when used for receiving goods by weight. The remote indicator easily mounts on a table or wall and features a large 1"/25 mm display, units conversion, and tare. Battery powered, these scales are portable so you can have a scale anywhere you need it. They also feature a RS-232 serial port.

MODEL	CAPACITY	UPC CODE
DR150	150 lb x 0.2 lb / 68 kg x 0.1 kg (mild steel)	809161130003
DR400	400 lb x 0.5 lb / 181 kg x 0.2 kg (mild steel)	809161130102
DR550	550 lb x 0.2 lb / 250 kg x 0.1 kg (stainless steel)	809161180701
DR400CASE	Carrying case	809161136609

Platform Dimensions: 12"W x 12"D / 31 cm x 31 cm

Display: 4 digit, 7 segment, liquid crystal display, 1" / 25 mm high

Power: 9 volts DC supplied by 6"AA" alkaline batteries (not included) or 115 volt AC adapter (included)

Shipping Weight: 13 lb / 6 kg

CS Series Digital Counting Scales

Take the guess work out of counting with the new CS series counting scales. Designed for portable use with a built-in rechargeable battery pack, the CS series is ideal for inventory when mobility is a must. This scale is ideal for multiple operators with the easy to use keypad. The built-in rechargeable battery pack with up to 200 hours of continuous use not only monitors the battery life, but also recharges the battery while the scale is in operation insuring no unexpected "down time."

MODEL	CAPACITY	UPC CODE
CS-6	6 lb x .0005 lb / 3 kg x 0.2 g	809161136708
CS-15	15 lb x .001 lb / 7.5 kg x 0.5 g	809161136807
CS-30	30 lb x .002 lb / 15 kg x 1 g	809161136906
CS-65	65 lb x .005 lb / 30 kg x 2 g	809161137002

Platform Dimensions: 11.38"W x 8.25"D / 29 cm x 21 cm

Overall Dimensions: 11.75"W x 12.63"D x 4.25"H / 30 cm W x 32 cm D x 11 cm H

Display: 0.75" high LCD with backlight

Power: Rechargeable battery pack or 115 VAC 50/60Hz or 230 VAC 50/60Hz

Shipping Weight: 13 lb / 6 kg

Portable Digital Platform Scales

Detecto receiving scales protect your profits and actually “pay for themselves” by accurately weighing commodities coming in your door. Constructed entirely of heavy-duty welded fabricated steel bases and electrostatically coated with long-life paint, these “legal-for-trade” platform scales provide fast, portable, accurate performances that let the weighing come to where you need it. Large 5” (127mm) diameter heavy-duty rubolene wheels make the scales easy to roll wherever they are needed and battery operation adds to their portability.

Choose from two different digital weight indicators to suit your specific need. The model 210 has most of the features of the 204, but also includes keypad tare and various other features. For 200 series weight indicator features, please see page 20 of this catalog.

MODEL	CAPACITY	UPC CODE
5852F-204	500 lb x 0.2 lb / 220 kg x 0.1 kg	809161123005
5852F-210	Same	809161122800
8852F-204	1000 lb x 0.5 lb / 440 kg x 0.2 kg	809161123104
8852F-210	Same	809161122909

Platform Dimensions: 19”W x 28” D / 48 cm W x 71 cm D

Power:

204: 6”C” size Alkaline batteries (not included). Optional AC power adapter available

210: 115/230 VAC

Shipping Weight: 108 lb / 49 kg



Notice of Approval
S.WA-4233
(5852F only)



Cert. No.
88-106A1



Assuring Accuracy In Your Shipments, Whether Incoming or Outgoing

Digital Bench Scale

Detecto’s Model 7045G digital bench scale, built to withstand rugged industrial environments, is perfect for inventory purposes, weighing bulk commodities or shipping and receiving departments. The 7045G’s model 204 digital indicator with 0.7”/18mm LCD display can be swiveled on its column so the user may turn it sideways for the best visibility. The base is 10.5”W x 14.5” D with a fixed auxiliary oversized galvanized platform, 18” W x 18” D with 4” upturned lip on back only.

Choose from pounds or kilograms readout with the switch selectable display that also features pushbutton tare. Long-life alkaline batteries add to this scale’s portability while the oven-baked enamel finish remains mar-resistant after years of rugged use. The galvanized L-shaped pan gives you a larger weighing surface without taking up as much counter space for the base. For 204 digital weight indicator features, please see page 20 of this catalog.

MODEL	CAPACITY	UPC CODE
7045G	400 lb x 0.2 lb / 180 kg x 0.1 kg	809161116205

Platform Dimensions: 10.5”W x 14.5” D (27 cm W x 37 cm D) with a fixed auxiliary oversized platform, 18”W x 18” D with 4” (46 cm W x 46 cm D x 10 cm H) upturned lip on back only.

Power: 6”C” size Alkaline batteries (not included). Optional AC power adapter available

Shipping Weight: 42 lb / 19 kg



Model
7045G



Model
1105DG



Optional
adjustable
wheeled
stand



Notice of Approval
S.WA-380 Rev. 1



LEGAL FOR TRADE

Cert. No.
89-032A2



Model
4420



REQUIRES ASSEMBLY



LEGAL FOR TRADE

Cert. No.
91-162

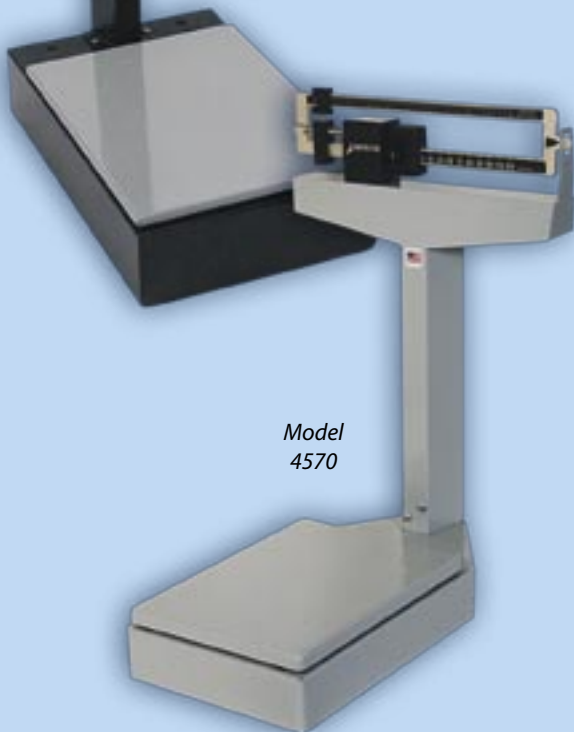

Model
4570

Bench Dial Scales

The 1100 series offers high accuracy and sturdy construction with minimum scale maintenance, due in part to the standard thermal elastic temperature-compensating springs and oil dashpot which add long-term accuracy.

MODEL	CAPACITY	UPC CODE
1100DB	50 lb x 1 oz	809161114706
1102DE	100 lb x 2 oz	809161114805
1102EDX	100 lb x 0.1 lb	809161114904
1105DG	200 lb x 4 oz	809161115000
1106DK	300 lb x 8 oz	809161115109
1100DBK	25 kg x 25 g	809161115208
1102EDK	50 kg x 50 g	809161115307
1106DKK	150 kg x 250 g	809161115406

ACCESSORIES		
259R922	"L" shaped stainless steel pan 18" W x 18" D x 4" H / 46 cm W x 46 cm D x 10 cm H	809161115505
948GR933	Adjustable wheeled stand	809161115604

Lb/kg models also available - please consult factory

Dial: 15" / 38 cm single dial, covered with glass

Platform Dimensions: 14" W x 18" D / 36 cm W x 46 cm D

Shipping Weight: 150 lb / 68 kg

"Legal for Trade" Bench Beam Scale

The scale's accuracy is further enhanced by its precision die-cast weighbeam which is easily read from both sides. Special tip locks and checks prevent the platform from tipping, protecting pivots and bearings.

MODEL	CAPACITY	UPC CODE
4420	350 lb x 4 oz	809161115703
4420KG	140 kg x 100 g (this model not "legal-for-trade")	809161115802

ACCESSORY		
259R922	"L" shaped stainless steel pan 18" W x 18" D x 4" H / 46 cm W x 46 cm D x 10 cm H	809161115505

Overall Height: 29.625" / 75 cm

Platform Dimensions: 14" W x 19" D / 36 cm W x 48 cm D

Shipping Weight: 49 lb / 22 kg

Beam Type Bench Scales

MODEL (UPC CODE)	CAPACITY	UPPER BEAM	LOWER BEAM
4570 809161115901	130 lb	10 lb x 1 oz	120 lb x 10 lb
4520 809161116007	350 lb	50 lb x .25 lb	300 lb x 50 lb
4527PK 809161116116	350 lb / 160 kg	50 lb x .25 lb / 20 kg x 100 g	300 lb x 50 lb / 140 kg x 20 kg

Overall Height: 27" / 69 cm

Platform Dimensions: 10.5" W x 14.5" D / 27 cm W x 37 cm D

Shipping Weight: 46 lb / 21 kg

General Utility Dial Scales

MODEL	CAPACITY	UPC CODE
47100-36	100 lb x 8 oz	809161112801
47200-36	200 lb x 1 lb	809161112900
47300-36	300 lb x 1 lb	809161113006



Model
47100-36



Model
48100-36B

Specialty Dial Counter Scales

MODEL	CAPACITY / DESCRIPTION	UPC CODE
4860-36B	60 lb x 2 oz (double lip pan)	809161113204
48100-36	100 lb x 8 oz (single lip pan)	809161113105
48100-36B	100 lb x 8 oz (single lip pan)	809161113303



ACCESSORIES		
5M35	Galvanized double lip pan 18" x 18" with 7" and 5" lip (46 cm x 46 cm x 18 cm x 10 cm)	809161113402
5M36 (Bananas)	Galvanized single lip pan 18" W x 18" D with 4" lip (46 cm x 46 cm x 10 cm)	809161113501

Dial: 10" / 25 cm single dial - covered with glass in painted sashes

Overall Height: 36" / 91 cm

Platform Dimensions: 10.5" W x 14.5" D / 27 cm W x 37 cm D

Shipping Weight: 54 lb / 24 kg

Portable Mechanical Platform Scales with Beam

MODEL (UPC CODE)	CAPACITY	FRONT OF BEAM	BACK OF BEAM
854F100P 809161114201	1,000 lb	100 lb x 0.5 lb	100 lb x 0.5 lb
854F50P 809161114300	500 lb	50 lb x 0.25 lb	50 lb x 0.25 lb
854F50K 809161114409	500 kg	50 kg x 0.25 kg	50 kg x 0.25 kg
854F50PK 809161114508	500 lb / 200 kg	20 kg x 100 g	50 lb x 0.25 lb
854F100PK 809161114607	1,000 lb / 500 kg	50 kg x 0.25 kg	100 lb x 0.5 lb

Overall Dimensions: 24" W x 35" D x 45" H / 61 cm W x 89 cm D x 114 cm H

Platform Dimensions: 19" W x 28" D / 48 cm W x 71 cm D

Wheels: Large 5"/13 cm diameter heavy duty rubolene wheels

Shipping Weight: 132 lb / 60 kg

Portable Mechanical Platform Scales with Beam

MODEL	CAPACITY	GRADS/BEAM	UPC CODE
954F100P	2000 lb	100 lb x 0.5 lb	809161114003
954F50K	1000 kg	50 kg x 0.25 kg	809161114102

Overall Dimensions: 33" W x 35" D x 45" H / 84 cm W x 89 cm D x 114 cm H

Platform Dimensions: 28" W x 28" D / 71 cm W x 71 cm D

Shipping Weight: 206 lb / 93 kg



LEGAL FOR TRADE

Cert. No.
88-106A1



Notice of Approval
S.WA-4233

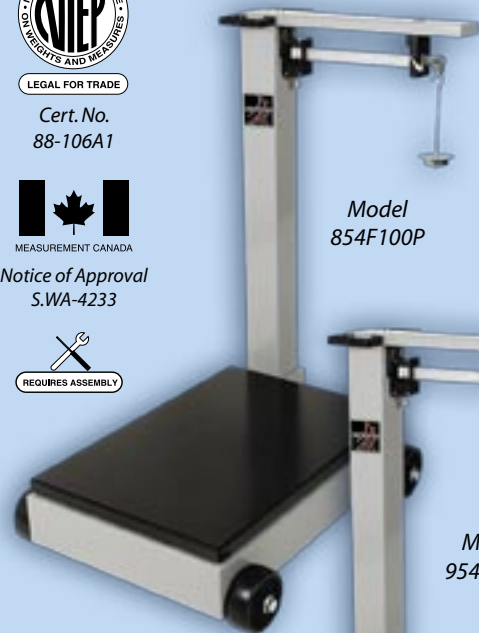

Model
854F100P



Notice of Approval
S.WA-4097



LEGAL FOR TRADE

Cert. No.
88-108A1



Model
954F100P



HEAVY-DUTY RECEIVING SCALES



Heavy-Duty Floor Scales

These floor scales come with the Cardinal model 204 digital weight indicator calibrated for the scale.



The **RuggedWeigh** above-ground platform scales provide the latest in weighing technology. These models are ideal for all types of manufacturing, food and chemical processing, and shipping and receiving operations where a heavy-duty floor scale is needed. The unique load cell assemblies are self-checking, incredibly well-protected, and environmentally sealed for those less-than-perfect locations. Other design features include a rigidly constructed checkered-deck weighbridge with easy-to-remove optional ramps. When necessary, the entire scale can be conveniently lifted, moved, and re-installed as your production and traffic flow needs change. Model 204 indicator included.

MODEL	PLATFORM SIZE	UPC CODE
Capacity: 5,000 lb x 1 lb		
FH-533-F-204	3' x 3' / .9 m x .9 m	809161180909
FH-500E	ramp for above model	809161181203
FH-544-F-204	4' x 4' / 1.2 m x 1.2 m	809161181005
FH-501E	ramp for above model	809161181302
FH-555-F-204	5' x 5' / 1.5 m x 1.5 m	809161181104
FH-502E	ramp for above model	809161181401

Approximate Shipping Weights:	FH-533-F-204	151 lb
	FH-544-F-204	282 lb
	FH-555-F-204	409 lb
	FH-500E	150 lb
	FH-501E	190 lb
	FH-502E	230 lb

RUN-A-WEIGH Portable Floor Scales

The Run-a-Weigh lets you put the scale where you need it, when you need it.



Weighing in at less than 100 pounds (45 kg) and featuring built-in handles and wheels, the **Run-a-Weigh** is easy to lift and roll to wherever you need it. Whether it's multiple weighing locations at a single facility or the need to take a scale to special job sites, the Run-a-Weigh gives you true portability.

This portable scale features a Cardinal model 204 digital weight indicator which can be mounted on the wall or desk for convenient viewing. Setup is simple and quick with the Run-a-Weigh's self-aligning feet. Heavy-duty construction, stainless steel load cells, large checkered safety platform with integral ramps, and the 500 or 1,000 lb (225 or 450 kg) capacity make this the perfect scale for weighing barrels, drums, and small crates - anywhere! The Run-a-Weigh lets you put a scale where you need it, when you need it.

MODEL	CAPACITY	UPC CODE
Platform Size: 30" L x 40" W / 76 cm L x 1 m W		
RW-500	500 lb x 0.2 lb / 225 kg x 0.1 kg	809161134100
RW-1000	1,000 lb x 0.5 lb / 450 kg x 0.2 kg	809161134209

Approximate Shipping Weight: 105 lb / 48 kg
Dimensions: 30" L x 40" W x 4.5" H / 76 cm L x 102 cm W x 11.5 cm H
Power: Six "C" cell or NiCad batteries, standard 12VDC (115 VAC 60 Hz adapter) or 115 VAC 60 Hz
Display: 5 digit, 7 segment, .1" high LCD
Output: RS-232

Detecto Step-On Can Waste Receptacles

Named for their rugged toughness, Detecto Step-On Cans are perfect for the food service industry. They come in a variety of five different sizes and capacities and two different materials listed below. The cans are flame retardant, have a self-closing lid for sanitation, epoxy polyester or stainless steel finish for easy cleaning, and full width hinges and unitized construction for long-term use. Detecto also includes free bio-hazard and infectious waste adhesive labels to meet OSHA labelling requirements.



Model
P-24



Model
P-24R



Model
C-24

Easy to clean plastic liners are ideal for use where disposable bags are not desired. (Model PL-32 Pictured)



Baked Epoxy Steel Step-On Cans

MODEL	CAPACITY	DIMENSIONS	SHIPPING WEIGHT	UPC
P-16 (white)	16 quart (4 gallon)	13" H x 11.33" W x 12.625" D / 33 cm H x 29 cm W x 32 cm D	12 lb / 5 kg	809161117608
P-24 (white)	24 quart (6 gallon)	16" H x 11.33" W x 12.625" D / 41 cm H x 29 cm W x 32 cm D	14 lb / 6 kg	809161117707
P-32 (white)	32 quart (8 gallon)	21" H x 11.33" W x 12.625" D / 53 cm H x 29 cm W x 32 cm D	16 lb / 7 kg	809161117806
P-48 (white)	48 quart (12 gallon)	23.5" H x 13.188" W x 14 " D / 60 cm H x 33 cm W x 36 cm D	20 lb / 9 kg	809161117905
P-100 (white)	100 quart (25 gallon)	27.5" H x 16.813" W x 17.625" D / 70 cm H x 43 cm W x 45 cm D	31 lb / 14 kg	809161118001
P-16R (red)	16 quart (4 gallon)	13" H x 11.33" W x 12.625" D / 33 cm H x 29 cm W x 32 cm D	12 lb / 5 kg	809161125900
P-24R (red)	24 quart (6 gallon)	16" H x 11.33" W x 12.625" D / 41 cm H x 29 cm W x 32 cm D	14 lb / 6 kg	809161126006
P-32R (red)	32 quart (8 gallon)	21" H x 11.33" W x 12.625" D / 53 cm H x 29 cm W x 32 cm D	16 lb / 7 kg	809161126105
P-48R (red)	48 quart (12 gallon)	23.5" H x 13.188" W x 14 " D / 60 cm H x 33 cm W x 36 cm D	20 lb / 9 kg	809161126204
P-100R (red)	100 quart (25 gallon)	27.5" H x 16.813" W x 17.625" D / 70 cm H x 43 cm W x 45 cm D	31 lb / 14 kg	809161126303

Stainless Steel Step-On Cans

MODEL	CAPACITY	DIMENSIONS	SHIPPING WEIGHT	UPC
C-16	16 quart (4 gallon)	13" H x 11.33" W x 12.625" D / 33 cm H x 29 cm W x 32 cm D	12 lb / 5 kg	809161118209
C-24	24 quart (6 gallon)	16" H x 11.33" W x 12.625" D / 41 cm H x 29 cm W x 32 cm D	14 lb / 6 kg	809161118308
C-32	32 quart (8 gallon)	21" H x 11.33" W x 12.625" D / 53 cm H x 29 cm W x 32 cm D	16 lb / 7 kg	809161118407
C-48	48 quart (12 gallon)	23.5" H x 13.188" W x 14 " D / 60 cm H x 33 cm W x 36 cm D	20 lb / 9 kg	809161118506
C-100	100 quart (25 gallon)	27.5" H x 16.813" W x 17.625" D / 70 cm H x 43 cm W x 45 cm D	31 lb / 14 kg	809161118605

Plastic Liners

MODEL	CAPACITY	SHIPPING WEIGHT	UPC
PL-16	16 quart (4 gallon)	2.75 lb / 1.2 kg	809161118704
PL-24	24 quart (6 gallon)	3.5 lb / 1.6 kg	809161118803
PL-32	32 quart (8 gallon)	4.5 lb / 2 kg	809161118902

UNIVERSAL GLOVE BOX HOLDERS



Conserve counter space with Detecto's model GH Universal Glove Box Holders. These sturdy units are available in three different sizes and two types of material.

Mild Steel Glove Box Holders

Detecto's model GH Glove Box Holders are available in three different sizes. Fit one glove box in the small GH1, two boxes side by side in the GH2, and three boxes side by side in the GH3. The all-steel construction with white powder coat finish carries a Detecto lifetime guarantee. The units install in seconds via screwholes and the GH1 also features a snap-on clip in back. The open design allows you to see what size or type of glove is being dispensed.

MODEL	DIMENSIONS	UPC
GH1 Holds 1 Box	10.5" H x 6.5" W x 4.25" D / 27 cm H x 17 cm W x 11 cm D	809161144901
GH2 Holds 2 Boxes	10" H x 12" W x 4" D / 25 cm H x 30 cm W x 10 cm D	809161145007
GH3 Holds 3 Boxes	10" H x 18" W x 4" D / 25 cm H x 46 cm W x 10 cm D	809161145106



PRIVATE LABELING OPTIONAL
QUANTITY PRICING AVAILABLE

Stainless Steel Glove Box Holders

Detecto's GHSS Stainless Steel Glove Box Holders are designed for holding latex glove boxes or tissues. Fit one glove box in the small GH1, two boxes side by side in the GH2, and three boxes side by side in the GH3. The all-stainless steel construction carries a Detecto lifetime guarantee. The units install in seconds via screwholes and the GH1 also features a snap-on clip in back. The open design allows you to see what size or type of glove is being dispensed.

MODEL	DIMENSIONS	UPC
GH1SS Holds 1 Box	10.5" H x 6.5" W x 4.25" D / 27 cm H x 17 cm W x 11 cm D	809161144604
GH2SS Holds 2 Boxes	10" H x 12" W x 4" D / 25 cm H x 30 cm W x 10 cm D	809161144703
GH3SS Holds 3 Boxes	10" H x 18" W x 4" D / 25 cm H x 46 cm W x 10 cm D	809161144802



1001T2B	Page 11	C-100	Page 21	MCS-20P	Page 13	T2	Page 7
1001T2BNS	Page 11	C-16	Page 21	MCS-40F	Page 13	T200	Page 7
1001TB	Page 11	C-24	Page 21	MCS-40H	Page 13	T25	Page 7
1001TBKG	Page 11	C-32	Page 21	MCS-40P	Page 13	T25B	Page 7
1001TBNS	Page 11	C-48	Page 21	MCS-60H	Page 13	T-25-S	Page 7
1002TB	Page 11	CS-15	Page 16	MCS-60M	Page 13	T25SB	Page 7
1002TBKG	Page 11	CS-30	Page 16	NB1418-125-205	Page 14	T2KP	Page 6
1002TBNS	Page 11	CS-6	Page 16	NB1418-125-210	Page 14	T2KPD	Page 6
1051TBS	Page 11	CS-65	Page 16	NB1418-30KG-205	Page 14	T25KP	Page 6
1051TBSKG	Page 11	DR150	Page 16	NB1418-30KG-210	Page 14	T25KPB	Page 7
1052TBS	Page 11	DR400	Page 16	NB1418-60-205	Page 14	T2R	Page 7
1052TBSKG	Page 11	DR400CASE	Page 16	NB1418-60-210	Page 14	T2RD	Page 7
1100DB	Page 18	DR550	Page 16	NB1418-60KG-205	Page 14	T-2-S	Page 7
1100DBK	Page 18	DS-12	Page 5	NB1418-60KG-210	Page 14	T-2-SD	Page 7
1102DE	Page 18	DS-30	Page 5	P-100	Page 21	T3530	Page 12
1102EDK	Page 18	DS-6	Page 5	P-100R	Page 21	T5	Page 7
1102EDX	Page 18	DS-60	Page 5	P-16	Page 21	T50	Page 7
1105DG	Page 18	EB-150-204	Page 15	P-16R	Page 21	T50B	Page 7
1106DK	Page 18	EB-150-205	Page 15	P-24	Page 21	T50KP	Page 7
1106DKK	Page 18	EB-150-210	Page 15	P-24R	Page 21	T5KP	Page 6
11S200H	Page 12	EB-150-LPAN	Page 15	P-32	Page 21	T-5-S	Page 7
11S200HKG	Page 12	EB-15-204	Page 15	P-32R	Page 21		
11S400H	Page 12	EB-15-205	Page 15	P-48	Page 21		
11S400HKG	Page 12	EB-15-210	Page 15	P-48R	Page 21		
1WK0500-1	Page 11	EB-15-LPAN	Page 15	P220	Page 4		
1WK1-1	Page 11	EB-300-204	Page 15	PC-10	Page 4		
1WK2-1	Page 11	EB-300-205	Page 15	PC-10KG	Page 4		
1WP1-1	Page 11	EB-300-210	Page 15	PC-20	Page 4		
1WP2-1	Page 11	EB-300-LPAN	Page 15	PC-20KG	Page 4		
1WP4-1	Page 11	EB-30-204	Page 15	PC-30	Page 4		
1WP8-1	Page 11	EB-30-205	Page 15	PC-30KG	Page 4		
204	Page 20	EB-30-210	Page 15	PL-16	Page 21		
259R922	Page 18	EB-30-LPAN	Page 15	PL-24	Page 21		
285R31	Page 11	EB-60-204	Page 15	PL-32	Page 21		
4420	Page 18	EB-60-205	Page 15	PS-4	Page 9		
4420KG	Page 18	EB-60-210	Page 15	PS-5A	Page 9		
4520	Page 18	EB-60-LPAN	Page 15	PS-6A	Page 9		
4527PK	Page 18	ET7	Page 8	PS-7	Page 9		
4570	Page 18	FH-500E	Page 20	PS-11	Page 9		
47100-36	Page 19	FH-501E	Page 20	PT-1	Page 6		
47200-36	Page 19	FH-502E	Page 20	PT-10SR	Page 6		
47300-36	Page 19	FH-533-F-204	Page 20	PT-1000RK	Page 6		
48100-36	Page 19	FH-544-F-204	Page 20	PT-1000SRK	Page 6		
48100-36B	Page 19	FH-555-F-204	Page 20	PT-1TF	Page 6		
4860-36B	Page 19	GH1	Page 22	PT-2	Page 6		
5852F-204	Page 17	GH1SS	Page 22	PT-25-R	Page 6		
5852F-210	Page 17	GH2	Page 22	PT-25SR	Page 6		
5M35	Page 19	GH2SS	Page 22	PT-2C	Page 6		
5M36	Page 19	GH3	Page 22	PT-2R	Page 6		
6100-0001	Page 11	GH3SS	Page 22	PT-2SR	Page 6		
6100-0002	Page 11	HSDC-100	Page 12	PT-5	Page 6		
6100-0003	Page 11	HSDC-100KG	Page 12	PT-25	Page 6		
6600-0220	Page 4	HSDC-20	Page 12	PT-5R	Page 6		
7045G	Page 17	HSDC-20KG	Page 12	PT-500RK	Page 6		
854F100P	Page 19	HSDC-200	Page 12	PT-500SRK	Page 6		
854F100PK	Page 19	HSDC-40KG	Page 12	PT-5SR	Page 6		
854F50K	Page 19	HSDC-50	Page 12	PZ3015	Page 10		
854F50P	Page 19	HSDC-500	Page 12	PZ3015LP	Page 10		
8852F-204	Page 17	HSDC-50KG	Page 12	PZ3030	Page 10		
8852F-210	Page 17	ICH1	Page 8	PZ3060	Page 10		
948GR933	Page 18	ICH2	Page 8	PZFS	Page 10		
954F100P	Page 19	MCS-10KGB	Page 13	PZPB	Page 10		
954F50K	Page 19	MCS-10KGF	Page 13	RW-1000	Page 20		
AP-10	Page 9	MCS-10KGH	Page 13	RW-500	Page 20		
AP-20	Page 9	MCS-10KGP	Page 13	T10	Page 7		
AP-4K	Page 9	MCS-20B	Page 13	T100	Page 7		
AP-6	Page 9	MCS-20F	Page 13	T-10-S	Page 7		
AP-8	Page 9	MCS-20H	Page 13	T10KP	Page 6		
AS-330D	Page 10	MCS-20KGF	Page 13	T10KPB	Page 7		
AS-333D	Page 10	MCS-20KGH	Page 13	T1KP	Page 6		
AS-334D	Page 10	MCS-20KGP	Page 13	T1KPD	Page 6		

DETECTO ONLINE

Detecto's entire product line is available for viewing online on our Web site: www.Detecto.com. Detecto aims to provide our customers with the most up-to-date and comprehensive product information and resources available anytime on the Web.

Go to www.Detecto.com for extensive Detecto product information, brochures, specification sheets, scale comparison charts, demonstration videos, ISO certification resources, company history, and "legal-for-trade" certifications; in addition to this catalog in PDF format, all just a click away.



OUR MISSION STATEMENT

Detecto is dedicated to the design and manufacture of innovative quality products of exceptional value to a world market. These efforts are monitored and communicated throughout the organization, in order to bring forth continuous improvement and growth for the Detecto family and our customers.

We will...promote an open environment encouraging creativity, team work, and total employee involvement.

We will...maintain a positive commitment to continual quality improvement essential for our customer's satisfaction.

We will...seek mutually beneficial long term relationships with our customers, distributors, suppliers, and community.

We will...adhere to sound business and environmental practices.

We will...strive to attract, develop, fairly reward, and provide secure employment for capable and committed employees.

We will...maintain a fair rate of return on investment to ensure the accomplishment of our mission.

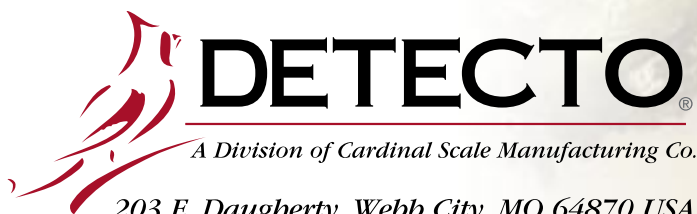

A Division of Cardinal Scale Manufacturing Co.

203 E. Daugherty, Webb City, MO 64870 USA
Ph: 417-673-4631 or 1-800-641-2008 Fax: 417-673-5001
www.Detecto.com

SOLD BY: