

(GVC) I-460 Rev. 02  
(GVT) I-470 Rev. 02

# **GVC Series**

*Installation, Operation  
and Maintenance Manual*



 **Carver<sup>®</sup>**

---

*Creating Value.*

## SERVICE RECORD PAGE

Service No. \_\_\_\_\_ Size and Type \_\_\_\_\_ Make \_\_\_\_\_

Cust. Order No. \_\_\_\_\_ Date Installed \_\_\_\_\_

| Installation Date | Location | Application |
|-------------------|----------|-------------|
|                   |          |             |
|                   |          |             |
|                   |          |             |
|                   |          |             |

### PUMP RATING

Capacity (GPM) \_\_\_\_\_ Total Head (ft) \_\_\_\_\_

Suction Pressure \_\_\_\_\_ Speed (RPM) \_\_\_\_\_

Liquid \_\_\_\_\_ Temperature \_\_\_\_\_

Specific Gravity \_\_\_\_\_ Viscosity \_\_\_\_\_

Impeller Diameter (inches) \_\_\_\_\_

### PUMP MATERIALS

Casings \_\_\_\_\_ Impeller \_\_\_\_\_ Diffuser \_\_\_\_\_

Shaft \_\_\_\_\_ Wear Ring \_\_\_\_\_

O-rings \_\_\_\_\_ Bearing Frame \_\_\_\_\_

Mechanical Seal, Suction End (Low Pressure) \_\_\_\_\_

Mechanical Seal, discharge End (High Pressure) \_\_\_\_\_

### DRIVER DATA

Motor \_\_\_\_\_ Make \_\_\_\_\_ Serial No. \_\_\_\_\_

Type \_\_\_\_\_ Frame \_\_\_\_\_ AC or DC \_\_\_\_\_

HP \_\_\_\_\_ RPM \_\_\_\_\_ Volts \_\_\_\_\_

Phase \_\_\_\_\_ Cycles \_\_\_\_\_

**NOTES ON INSPECTION AND REPAIRS**

| INSPECTION DATE | REPAIR TIME | REPAIRS | COST | REMARKS |
|-----------------|-------------|---------|------|---------|
|                 |             |         |      |         |

# TABLE OF CONTENTS

| LOCATION/DESCRIPTION                   | PAGE  | LOCATION/DESCRIPTION  | PAGE         |
|--|-------|---|--------------|
| • SERVICE RECORD PAGE .....            | FRONT |   |              |
| • NOTES ON INSPECTION AND REPAIRS..... | FRONT |   |              |
| I. GENERAL INFORMATION .....           | 1     |   |              |
| A. Preface.....                        | 1     |   |              |
| B. Pump Identification .....           | 1     |   |              |
| C. Parts Inventory Guide .....         | 1     |   |              |
| D. Parts Ordering.....                 | 1     |   |              |
| E. Safety Precautions.....             | 1     |   |              |
| II. INSPECTION AND STORAGE ...         | 2     |   |              |
| A. Inspection Upon Arrival.....        | 2     |   |              |
| B. Storage of Pump.....                | 2     |   |              |
| III. INSTALLATION .....                | 4     |   |              |
| IV. ALIGNMENT.....                     | 4     |   |              |
| V. OPERATION.....                      | 4     |   |              |
| A. Prestart Cautions .....             | 4     |   |              |
| B. Starting the Pump .....             | 4     |   |              |
| C. Stopping the Pump .....             | 4     |   |              |
| VI. MAINTENANCE.....                   | 5     |   |              |
| A. Field Inspection.....               | 5     |   |              |
| B. Stuffing Box.....                   | 5     |   |              |
| C. Bearing Temperature .....           | 5     |   |              |
| D. Bearing Lubrication.....            | 5     |   |              |
| VII. TROUBLESHOOTING.....              | 6     |   |              |
| VIII. SERVICE AND REPAIR .....         | 9     |   |              |
| A. Disassembly and Assembly....        | 9     |   |              |
| B. Parts Inspection .....              | 14    |   |              |
|  |       | C. Adjusting Impeller Clearance on Pump Equipped with Semi-Open Impeller.....     | 16           |
|  |       | D. Replacement of Optional Wear Ring on Pump Equipped with Enclosed Impeller..... | 16           |
|  |       | IX. PARTS LIST AND FIGURES .....  | 17           |
|  |       | <b>LIST OF TABLES</b>   |              |
|  |       | <b>TABLE</b>  | <b>TITLE</b> |
|  |       |   | <b>PAGE</b>  |
|  |       | A. Recommended Torque Values .....  | 5            |
|  |       | 1. Troubleshooting .....  | 7            |
|  |       | 2. Throttle Bushing Dimensions .....  | 15           |
|  |       | 3. Enclosed Impeller Clearance .....  | 15           |
|  |       | 4. Impeller/Wear Ring Matching Materials.....                                     | 16           |
|  |       | 5. Recommended Spare Parts.....   | 17           |
|  |       | 6. Pump Parts List for GVC 1520 and GVC 1530/1540 .....                           | 18           |
|  |       | 7. Pump Parts List for GVT 1520 and GVT 1530/1540.....                            | 18           |
|  |       | <b>LIST OF ILLUSTRATIONS</b>  |              |
|  |       | <b>FIGURE</b>   | <b>TITLE</b> |
|  |       |   | <b>PAGE</b>  |
|  |       | A. Ordering Codes.....  | 3            |
|  |       | 1. GVC (1520 Frame) Sectional Drawing .....                                       | 19           |
|  |       | 2. GVC (1530 Frame) Sectional Drawing .....                                       | 20           |
|  |       | 3. GVC (1540 Frame) Sectional Drawing .....                                       | 21           |
|  |       | 4. GVT (1520 Frame) Sectional Drawing .....                                       | 22           |
|  |       | 5. GVT (1530 Frame) Sectional Drawing .....                                       | 23           |
|  |       | 6. GVT (1540 Frame) Sectional Drawing .....                                       | 24           |
|  |       | 7. Optional Wear Ring.....  | 25           |

## I. GENERAL INFORMATION

**A. PREFACE.** General vertical cantilevered (GVC) pumps are designed for industrial service. All wetted surfaces are available in all iron, stainless fitted, and stainless steel construction. The general vertical top pullout (GVT) design provides fast, easy access to all working parts without disconnecting pipes.

**B. PUMP IDENTIFICATION.** The type of pump, pump size, operating data, and serial number are all stamped on the nameplate attached to the pump. Pump specifications should be recorded upon receipt of the pumping unit. Record all necessary information on the pump service record page and inspection and repair record provided at the front of this manual. When ordering spare parts, check to make sure that the serial number and model number of the pump are correct. When ordering a pump, refer to Figure A, Ordering Codes. This information must be included in all correspondence regarding the unit. This will ensure that the correct pump and/or parts are ordered in a timely manner.

**C. PARTS INVENTORY GUIDE.** To avoid unnecessary delays during maintenance of pump, spare parts should be readily available for normal service. Most matters can be handled with proper usage of this manual. For every one to three pumps, stock one spare set consisting of items listed in Table 5, Recommended Spare Parts. Part numbers correspond to the drawings (figures 1 through 7) found at the back of this manual.

A nameplate is attached to each pump. The data on the nameplate should be recorded and filed for easy reference. Nameplate data should be furnished to Carver Pump Company or its representative when ordering spare parts or requesting information.

**D. PARTS ORDERING.** Carver Pump Company strives to provide prompt, accurate service. To ensure quality customer service, please provide the following information:

- Serial number of pump (located on nameplate)
- Part name (refer to Table 6 and Table 7)
- Item number (refer to Table 6, Table 7, and figures 1 through 7)
- Quantity of parts needed

Carver may ship an interchangeable part that is not identical in appearance or symbol. This is done only if the part has been improved. Examine the parts carefully on receipt before calling the factory or a company representative. Never return parts to the factory without authorization from Carver Pump Company.

If an impeller is ordered, specify diameter across blade tips. Check to make sure diameter was NOT trimmed further than diameter shown on Carver Pump Company records.

If a motor/motor parts are ordered, specify the name of the manufacturer and all other data found on the driver nameplate.

**E. SAFETY PRECAUTIONS.** This manual contains descriptions and instructions, which are the result of carefully conducted engineering and research efforts. The manual is written with the intent to provide instructions for the safe and efficient installation, operation, and maintenance of the pump. Failure or neglect to properly install, operate, or maintain the pump may result in personal injury, property damage, or unnecessary damage to the pump and/or parts.

Variations exist in both the equipment used with these pumps and in particular, installation of the pump and driver. Therefore, specific operating instructions are not within the scope of this manual. This manual contains general rules for installation, operation, and maintenance of the pump.

Observe and understand all caution or danger tags attached to the equipment. Observe and understand all cautions and warnings included in this manual.

The following general safety precautions do not relate to any specific procedure within this manual but are pertinent to providing a safe working environment for personnel.

### CAUTION

Various federal, state and local laws and the regulations concerning OSHA affect installation, use, and operation of pumping equipment. Compliance with such laws relating to the proper installation and safe operation of pumping equipment is the responsibility of the equipment owner and all necessary steps should be taken by the owner to assure compliance with such laws before operating the equipment.

### PUMP

1. Hydro suction case separately if unit hydro is greater than 620 PSIG.
2. Isolate pump for system hydro.
3. Do NOT exceed maximum suction pressure of 415 PSIG on suction case.
4. Do NOT exceed maximum discharge pressure of 1200 PSIG on discharge case.

### DRIVER

5. Prior to working on pump or driver, ensure all switches and circuit breakers have been locked in the open (off) position and tagged, "Out of Service."
6. All circuits NOT known to be dead must be considered live at all times.
7. Do NOT wear loose or torn clothing around rotating machines. Do NOT wear jewelry or watches around rotating machines.
8. While working near electricity, do NOT use metal rules, flashlights, metallic

- pencils, or any other objects having exposed conducting material.
9. Ensure you are NOT grounded while adjusting electrical equipment or using measuring equipment.
  10. In general, use only one hand when servicing live electrical equipment.
  11. De-energize all electrical equipment before connecting or disconnecting meters or test leads.
  12. When connecting a meter to terminals for measurement, use a range higher than the expected voltage.
  13. Check to make sure the frame of the driver and starter panel are securely grounded before operating pumping unit or performing any tests or measurements.
  14. If a test meter is held or adjusted while voltage is applied, ground case of meter before starting measurement. Do NOT touch live equipment while holding meter. Some moving vane-type meters should not be grounded nor held during measurements.
  15. Do NOT use test equipment known to be damaged or in poor condition.
  16. Reference Table A, Torque Values, to avoid equipment damage and injury to personnel.

## **II. INSPECTION AND STORAGE**

---

**A. INSPECTION UPON ARRIVAL.** Upon receipt of the shipment, check for missing or damaged items. Unpack and inspect the pump, driver assemblies, and individual parts. Carefully inspect all boxes and packing material for loose parts before discarding. Immediately report any missing parts or damage incurred during shipment to the factory and to the transportation company. File your “damaged and/or lost in shipment” claim with the carrier.

### **NOTE**

The pump and equipment, as shipped from Carver Pump Company, have appropriate protection for short-term storage. If the equipment is NOT immediately installed and operated, store the equipment in a covered, clean, dry, well-ventilated location, free from vibrations, moisture, and rapid or wide variations in temperature.

**B. STORAGE OF PUMP.** If the equipment is NOT immediately installed and operated, Carver Pump Company recommends rotating each shaft several revolutions at least once every two weeks to prevent flat spots on ball bearings.

Consider a unit to be in storage when any of the following situations occur:

- The pump has been delivered to the job site and is waiting to be installed.
- The pump has been installed but operation is delayed pending completion of construction.
- There are long (30 days or more) periods between operating cycles.
- The plant (or department) is shut down for periods of longer than 30 days.

### **CAUTION**

A pump, which is made of cast or ductile iron that sits in extreme heat, high humidity, or full or partially full water over 30 days will rust and will most likely seize. If the pump rusts and/or seizes, a complete overhaul and repair may be necessary to refurbish the pump.

Storage requirements vary depending on the length of storage, the climatic environment, and the equipment. For storage periods of three months or longer, contact a representative from Carver Pump Company for specific instructions. Improper storage will damage the equipment and will require non-warranty restoration and/or non-warranty product failures. Refer to Section VIII, Service and Repair, for pump disassembly and assembly procedures. When disassembling the pump, replace and repair rusted parts, as necessary.

### **NOTE**

If the customer anticipates the pump/equipment will be subject to an extended period of storage after installation, (for example, a unit used for seasonal operation), contact a representative from Carver Pump Company. If this is the case, Carver will provide specific instructions for the equipment during the extended period of storage. In general, if a pump is to be shut down for an extended period, the following steps are recommended:

1. Shut down the pumping unit in accordance with the operating procedures outlined throughout this manual.
2. Shut off system suction and discharge valves.
3. Drain the unit.
4. Fill unit with mineral oil or suitable non-corrosive protectant that is compatible with the system.
5. Provide pump and motor with a protective cover.

The following Ordering Code defines the new GV Series pump and pump/motor and top plate arrangements. When quoting or ordering a GV pump, **this Ordering Code must be used**. This

Ordering Code enables Carver Pump Company to accept orders quickly, assuring timely and correct manufacture of the desired pump.

## EXAMPLE

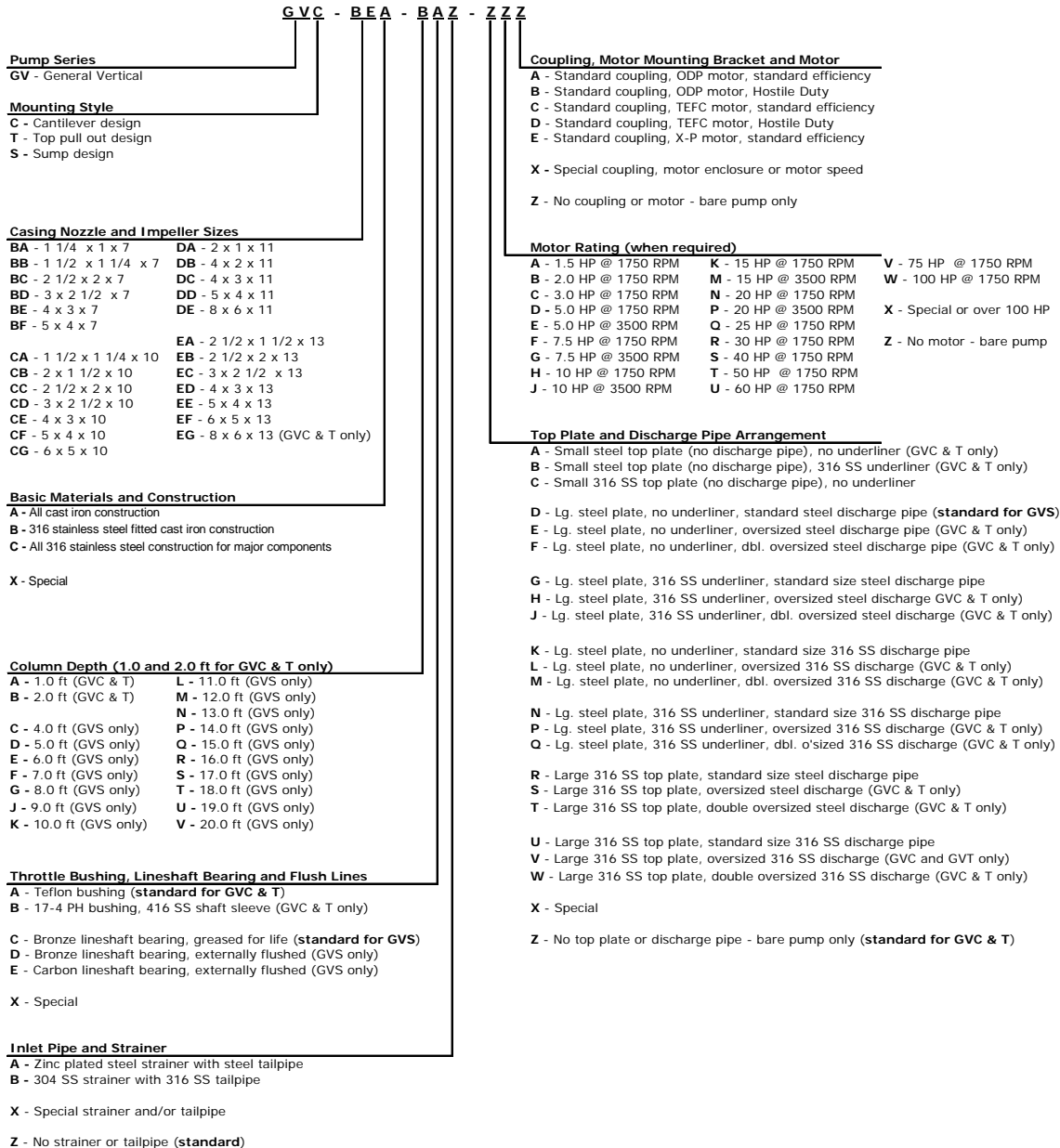

\* Casing Nozzle and Impeller Sizes containing codes BA through BF and CA through CG have semi-open impellers. Casing Nozzle and Impeller Sizes containing codes DA through DE and EA through EG have closed impellers.

Figure A. Ordering Codes

### III. INSTALLATION.

---

Skilled personnel should install the pump in accordance with engineering standards. Faulty installation will result in operating troubles and premature wear of parts.

The pump and driver should be easily accessed with enough headroom to perform periodic inspection and maintenance. The pump should always be submerged enough to prevent vortices from forming, which might allow air to enter the suction.

When pump is supplied with coupling, motor, and baseplate, the complete set is assembled at Carver Pump Company. After ascertaining that the unit has suffered no damage in transit, one may install the pumping unit. Proceed as follows:

1. Make sure the mounting surface is level. Attach the base to the mounting surface. Check that pump rotates freely.

#### **CAUTION**

Pipe strain will cause wear and/or damage to parts.

2. Connect discharge piping. Extreme care should be taken when connecting new piping lines to be sure that no foreign matter such as dirt, chips, tools, etc., is in the piping, tank, or return piping as the debris will be drawn into the pump and cause excessive damage. Any debris caught in the pump passageways will throw the pumping unit out of balance.
3. Connect any necessary auxiliary piping and gauge lines.
4. Since the pumping unit is shipped with bearings packed, initial greasing will not be necessary unless pumping unit has been in storage for an extended period of time (refer to section II).
5. Turn pump and motor shafts by hand to be sure they rotate freely.
6. Connect wiring to motor. Due to high voltage required to operate the pumping unit, personnel working with the equipment should be familiar with electrical safety practices and modern methods of resuscitation.
7. Connect electrical power supply to motor.
8. Open system valves.

### IV. ALIGNMENT.

---

A flexible coupling connects the pump and motor.

The motor bracket aligns the pump and motor. No further alignment is necessary.

### V. OPERATION.

---

#### A. PRESTART CAUTIONS.

1. Before starting or operating the pump, read this entire manual, especially the following instructions.
2. Before starting the pump, rotate shaft by hand to assure all moving parts are free.
3. Before starting the pump, install closed guards around all exposed rotating parts.
4. Observe all caution or danger tags attached to the equipment.
5. Never run pump dry. Dry running may result in pump seizure.
6. If excessive vibration or noise occurs during operation, shut the pump down and consult a Carver representative.
7. Use of a check valve in discharge piping is recommended if there is a high volume of reverse flow.
8. Check level in tank to see that the pump is submerged in fluid.

**B. STARTING THE PUMP.** The pumping unit will operate without operator intervention once system valves have been adjusted to the specified pumping conditions. The casing of the pump will be submerged in the fluid being pumped, thus rendering it self-priming. Proceed with operation as follows:

1. Make sure no one is working on the pumping unit.
2. If the pumping unit has been idle for a period of time, make sure unit is firmly attached to its foundation.
3. Open valves to pressure gauges in system.

#### **CAUTION**

Check level of liquid in tank to be sure casing is under liquid level.

4. Jog starter switch on motor to check direction of rotation. Direction of rotation is clockwise from fan end of motor.
5. Partially open discharge valve.
6. Start the pumping unit in accordance with the directions on the electrical power supply.
7. Slowly adjust discharge valve to operating condition required.
8. Pumping unit is now in full operation.

**C. STOPPING THE PUMP.** To stop the pump, use the following process:

1. If pump is being stopped for overhaul, slowly close the discharge valve. Otherwise leave discharge valve set at condition.
2. Stop the pumping unit in accordance with the directions on the electrical power supply.
3. If the pump is being stopped for overhaul, close pressure gauge valves.



- The pumping unit is now in the off position.

## VI. MAINTENANCE.

Generally, the pump does not require continuous supervision. Occasional visual checks are recommended. Data should be recorded for each pump to keep track of maintenance, which has been performed and note operational problems. A pump service record page is provided for this purpose in the front matter of this manual.

Before disassembly/assembly, review Table A, Torque Values to avoid equipment damage and injury to personnel.

**Table A. Recommended Torque Values (ft-lbs)**

| Bolt Size | Material  |                            |                     |
|-----------|-----------|----------------------------|---------------------|
|           | Composite | Steel (or otherwise noted) | 316 Stainless Steel |
| 1/4"-20   | 5         | 5                          | 7                   |
| 5/16"-18  | 11        | 11                         | 12                  |
| 3/8"-16   | 18        | 18                         | 21                  |
| 1/2"-13   | 33        | 39                         | 45                  |
| 5/8"-11   | 54        | 83                         | 97                  |
| 3/4"-10   | 80        | 105                        | 132                 |
| 7/8"-9    | 109       | 160                        | 203                 |
| 1"-8      | 144       | 236                        | 300                 |

**A. FIELD INSPECTION.** Shutdown is not required. Perform field inspection at regular intervals and cover the following procedures:

- Check and record the suction and discharge pressures to establish differential head. It should conform to the pump nameplate.
- Check and record the power input and speed of the driver.
- Check and record pumping temperatures.
- Check pump for quiet running.

**B. STUFFING BOX.** The stuffing box is equipped with a throttle bushing which requires no regular maintenance. The inside diameter of the throttle bushing will increase with wear. The throttle bushing should be inspected after pump disassembly. The throttle bushing requires replacement if the inside diameter is more than 0.020 inch out of round.

**C. BEARING TEMPERATURE.** Bearing temperature should be monitored periodically. Normal operating temperatures are 120 degrees F to 160 degrees F, depending on the ambient temperature. Bearings may appear to run hot when pump is first started. This is caused by the shaft seal, not the bearing. When the seal is seated, temperature should drop to normal.

Check bearing temperature by placing a pyrometer against the bearing frame while pump is running. A temperature rise above 180 degrees F indicates possible damage that requires checking. The most common cause of high bearing temperatures is overgreased bearings.

**D. BEARING LUBRICATION.** Lubrication frequency depends on operating conditions. Normal duty calls for relubrication every 1000 hours of operation. Bearings are lubricated at Carver Pump Company with Amoco Rykon Premium Grease No. 2EP, non-soap, polyurea thickened grease with a drop point of 450 degrees F. This grease was selected due to its suitability to extreme pressures and its high temperature stability. Never mix greases with differing properties.

Polyurea base greases are NOT compatible with lithium or soda soap base greases. Therefore, the type of grease added should not vary. However, if it is necessary to change grease types, the bearings, bearing frame, and bearing cap/cartridge should be thoroughly cleaned and flushed with suitable solvent to remove all traces of old grease. Disassemble pump, remove shaft and bearings from bearing frame, and follow these procedures:

- Place bearings, bearing frame, and bearing cap/cartridge in a wire or mesh basket and suspend the basket in a light mineral solvent. Allow it to soak, preferably overnight.
- After soaking and cleaning, the bearings, bearing frame, and bearing cap/cartridge should be rinsed in a clean, light mineral solvent and agitated vigorously to remove all loosened hard grease and dirt.
- Dip bearings in clean, light oil and spin by hand to determine that all foreign matter has been removed.
- After cleaning, repack bearings half full on both sides with a good quality ball bearing grease.

To relubricate bearings use the following procedure:

### **CAUTION**

Overgreasing creates heat and is the cause of many problems requiring repair. **DO NOT OVERGREASE.**

- Never relubricate pump bearings while unit is running. If necessary, shut down pump according to section V, paragraph C.
- Remove plugs opposite grease fittings on both ends of bearing frame.

### **CAUTION**

Do not lubricate bearings with a power grease gun.

3. Using a hand-operated grease gun on grease fittings, add approximately one ounce of fresh grease for each bearing. With most hand-operated grease guns, two or three pumps are enough. **DO NOT OVERGREASE.** When installing new bearings, pack new bearings only half full with grease.

Bearing temperature may rise above normal immediately after lubrication, but should stabilize within four to eight hours.

### **NOTE**

Carver recommends replacing bearings if removed from the shaft. If it is necessary to reuse bearings that are in good condition, use proper bearing replacement procedures outlined in this section.

## **VII. TROUBLESHOOTING.**

The pump should provide reliable service and long life if the installation and starting procedures outlined in this manual are followed. If operating problems do occur, refer to Table 1 to eliminate some of the most common causes of those problems.

**Table 1. Troubleshooting**

| SYMPTOM                           | PROBABLE CAUSE  | REMEDY  |
|-----------------------------------|---|---|
| Motor will not start.             | <ol style="list-style-type: none"> <li>1. No input power.</li> <li>2. Improper voltage.</li> <li>3. Motor overload.</li> <li>4. Mechanical obstruction that prevents rotor from turning.</li> </ol>   | <ol style="list-style-type: none"> <li>1. Check connections to electrical power source. Check fuses or circuit breakers. Check terminals at source of power input.</li> <li>2. Check voltage at motor terminals.</li> <li>3. Refer to "Overload on motor".</li> <li>4. Examine and clean pumping unit thoroughly. Check for bearing failure or bent shaft.</li> </ol>   |
| Motor overheats.                  | <ol style="list-style-type: none"> <li>1. Motor overload.</li> <li>2. Improper voltage.</li> <li>3. Obstruction in ventilation.</li> <li>4. Insufficient cooling medium.</li> <li>5. Overgreased motor bearings.</li> <li>6. Improper motor grease.</li> </ol>  | <ol style="list-style-type: none"> <li>1. Refer to "Overload on motor".</li> <li>2. Check voltage at motor terminals.</li> <li>3. Check ventilation opening of motor. Keep clear of obstructions at all times.</li> <li>4. Check ambient temperature. Motor temperature should not exceed ambient temperature plus the rated temperature increase of the unit.</li> <li>5. Remove lubricant from bearing chamber until the proper amount of grease is in chamber.</li> <li>6. Remove grease and replace with grease recommended by motor manufacturer.</li> </ol> |
| Failure to deliver fluid.         | <ol style="list-style-type: none"> <li>1. Discharge valve closed.</li> <li>2. Discharge head above shutoff.</li> <li>3. Impeller or suction pipe clogged.</li> <li>4. Wrong rotation.</li> <li>5. Liquid level in tank too low.</li> </ol>  | <ol style="list-style-type: none"> <li>1. Check discharge valve.</li> <li>2. Consult with nearest Carver Pump Company representative or factory.</li> <li>3. Inspect and clean impeller and suction pipe.</li> <li>4. Check power connection to motor.</li> <li>5. Add liquid to system.</li> </ol>   |
| Reduced capacity and/or pressure. | <ol style="list-style-type: none"> <li>1. Discharge valve closed.</li> <li>2. Damaged impeller.</li> <li>3. Impeller or suction pipe partially clogged.</li> <li>4. Suction pipe too close to bottom of tank.</li> <li>5. Liquid level in tank too low.</li> <li>6. Total head too high.</li> <li>7. Wrong rotation.</li> </ol> | <ol style="list-style-type: none"> <li>1. Check discharge valve.</li> <li>2. Replace impeller.</li> <li>3. Inspect and clean impeller and suction pipe.</li> <li>4. Reduce length of pipe.</li> <li>5. Add liquid to system.</li> <li>6. Consult with nearest Carver Pump Company representative or factory.</li> <li>7. Check power connections to motor.</li> </ol>   |

**Table 1. Troubleshooting (cont.)**

| SYMPTOM                                  | PROBABLE CAUSE  | REMEDY  |
|--|---|---|
| Reduced capacity and/or pressure (cont). | <ol style="list-style-type: none"> <li>8. Speed too low.</li> <li>9. Semi-open impeller running clearance too large.</li> <li>10. Enclosed impeller clearance between suction cover or wear ring, if equipped, is too large.</li> </ol>   | <ol style="list-style-type: none"> <li>8. Consult with nearest Carver Pump Company representative or factory.</li> <li>9. Check semi-open impeller clearance according to section VIII, paragraph D.</li> <li>10. Check enclosed impeller clearance according to section VIII paragraph B, procedure seven.</li> </ol>  |
| Pump surges                              | <ol style="list-style-type: none"> <li>1. Liquid level in tank too low.</li> </ol>  | <ol style="list-style-type: none"> <li>1. Add liquid to system.</li> </ol>  |
| Pump loses prime after starting.         | <ol style="list-style-type: none"> <li>1. Suction lift is over six feet.</li> <li>2. Liquid level in tank too low.</li> </ol>   | <ol style="list-style-type: none"> <li>1. Check with vacuum gauge.</li> <li>2. Add liquid to system.</li> </ol>   |
| Overload on motor.                       | <ol style="list-style-type: none"> <li>1. Head lower than that for which pump is designed.</li> <li>2. Mechanical defects of pump or motor such as bent shaft, binding or rubbing rotating element.</li> <li>3. Liquid handled of higher specific gravity or lower viscosity than intended application.</li> </ol>                          | <ol style="list-style-type: none"> <li>1. Consult with nearest Carver Pump Company representative or factory.</li> <li>2. Replace defective parts or replace pump or motor.</li> <li>3. Consult with nearest Carver Pump Company representative or factory.</li> </ol>  |
| Insulation failure.                      | <ol style="list-style-type: none"> <li>1. Oil or water soaked windings.</li> <li>2. Improper voltage.</li> </ol>  | <ol style="list-style-type: none"> <li>1. Return motor to the motor manufacturer.</li> <li>2. Check voltage at motor terminals.</li> </ol>  |
| Vibrates or is noisy                     | <ol style="list-style-type: none"> <li>1. Insufficient or insecure foundation.</li> <li>2. Mechanical defects of pump or motor such as bent shaft, binding rotating element, or warped impeller.</li> <li>3. Foreign matter in pump.</li> <li>4. Strain due to piping or improper piping supports.</li> <li>5. Damaged bearings.</li> </ol> | <ol style="list-style-type: none"> <li>1. Enlarge foundation or relocate pumping unit so it can be firmly bolted to foundation.</li> <li>2. Replace defective parts or replace pump or motor.</li> <li>3. Disassemble pump. Identify and remove foreign matter. Clean parts and replace damaged parts.</li> <li>4. Check piping alignment and remove piping weight from pump with proper supports.</li> <li>5. Replace bearings.</li> </ol> |

## VIII. SERVICE AND REPAIR.

**A. DISASSEMBLY AND ASSEMBLY.** Read this entire section and study figures one through seven of this manual.

1. Stop pump in accordance with section V, paragraph C. Disconnect, lock out, and tag electrical power supply to motor. Disconnect wiring from motor.
2. Shut off and tag all valves controlling the flow of liquid to the tank and from the pump. If necessary, flush pump to remove corrosive or toxic pumpage.

The GVC pumps are of the same basic design, but some parts do vary between models. Parts that may vary from model to model are: semi-open or enclosed impeller, wear ring (enclosed impeller pumps only), and shaft sleeve. The top pullout design of the GVT pump allows the shaft and impeller to be removed without disconnecting the piping or casing.

### **NOTE**

Prior to assembly, refer to the following paragraphs in this section: Parts Inspection, paragraph B, Adjusting Impeller Clearance, paragraph C, and Wear Ring Replacement, paragraph D.

During disassembly, mark parts to determine the proper location when assembly begins. When removing capscrews, use socket or box-ended wrenches instead of open-ended wrenches. After extended operation, it may be difficult to separate some components. Rust solvent may be used and suitable extricating tools where possible. Do not use metal-headed hammers; use only those with plastic or rubber heads.

### **CAUTION**

To avoid damaged o-rings, check to make sure all parts are free of sharp edges or burrs.

After prolonged operation, components may not be easily removed from shaft. In such instances, rust solvent may be used and suitable extracting tools applied wherever possible. Do NOT use force under any circumstances.

Refer to appropriate sectional drawing, for location of parts followed by an item number. Assemble the pump in accordance with accepted rules of engineering practice.

**GVC, 1520 FRAME (Cantilevered)** (Refer to Figure 1 and Table 6)

### **DISASSEMBLY**

Disassemble the pumping unit using the following procedure:

1. Remove coupling guard (131). Disconnect coupling (42).

### **WARNING**

To lift motor, a hoist or suitable lifting device must be used.

2. Attach hoist to motor. Remove capscrews (607), freeing motor from motor bracket (19). Hoist motor and motor coupling half away from pump and rest on plywood, heavy cardboard or other adequate durable surface.
3. Attach lifting straps and eyebolts to base (23). Take to a suitable work area.
4. Remove bolts (611). Remove suction cover (9) with o-ring (89A).

### **NOTE**

Replace used o-rings, seals and bearings with new o-rings, seals and bearings.

5. Remove impeller bolt (26) and impeller washer (28).
6. Remove impeller (2) and impeller key (32).

### **CAUTION**

Do NOT pry composite parts. Damage may occur to composite parts if they are struck with force, pounded with a metal object or pried.

7. Remove shaft sleeve (14), if equipped. Refer to sectional drawings, Optional Sleeve detail.
8. Remove nuts (617) with bolts (604) and washers (654).

### **WARNING**

To lift bearing housing, use a hoist or suitable lifting device.

9. Remove bearing housing (19) assembly and shaft (6).
10. Inspect throttle bushing (63) in accordance with paragraph C, procedure 5 and Table 2 of this section. Do NOT remove throttle bushing (63) and o-ring (89X), unless necessary.

### **NOTE**

Do NOT disassemble column (101) from casing (1) or base (23), unless necessary.

11. Remove coupling half on pump side and remove coupling key (46).
12. Loosen setscrew (667) to remove bearing cap (37).
13. Remove bearings (16) and (18) with shaft (6) assembly from bearing housing (19).
14. Remove outer snap ring (176).
15. Remove bearings (16) and (18) from shaft (6).
16. Remove bearing spring (449).

### **ASSEMBLY**

Assemble the pumping unit using the following procedures:

### **NOTE**

Carver recommends that grease seals (47), o-ring (89), and locking devices with a nylock feature be replaced with new if disturbed from position.

Carver recommends that bearings (16 and 18) be replaced if removed from shaft.

1. Install bearing spring (449) onto shaft (6) between two bearing seats.
2. Install upper bearing (16) and lower bearing (18) onto shaft (6). Bearings may be pressed onto shaft or heated so they slide onto shaft. Pack bearings half full of grease. Refer to section VI, paragraph D for proper grease type.
3. Install outer snap ring (176).
4. Install shaft and bearings into bearing housing (19).
5. Install new grease seal (47) in bearing cap and grease seal (47A) in column (101).
6. Install bearing cap (37) and hand tighten.
7. Install coupling key (46) and slide coupling half onto pump.
8. If throttle bushing (63) was removed, press new throttle bushing (63) and o-ring (89X) into column (101).

### **WARNING**

To lift bearing housing, use a hoist or suitable lifting device.

9. Install bearing housing assembly and shaft (6) into column (101) and secure with bolts (604), washers (654), and nuts (617).
10. Install shaft sleeve (14), if equipped. Refer to sectional drawings, Optional Sleeve detail.

### **CAUTION**

Use removable thread locker when installing impeller bolt.

11. Install impeller key (32) and impeller (2) and secure with washer (28) and bolt (26).
12. Install new o-ring (89A) onto suction cover (9).
13. Install suction cover (9) and secure to casing (1) with bolts (611).
14. Adjust impeller in accordance with paragraph C of this section.
15. Attach lifting straps and eyebolts to base (23).
16. Install pumping unit back to site.
17. Attach hoist to motor and move motor and motor coupling half into place on motor bracket (19) and secure with bolts (607).
18. Refer to section IV for alignment information.
19. Reconnect coupling.

### **NOTE**

Rotate shaft by hand to make sure pump rotates freely before start-up.

**GVC, 1530/1540 FRAME (Cantilevered)** (Refer to Figure 2, Figure 3, and Table 6)

### **DISASSEMBLY**

Disassemble the pumping unit using the following procedure:

1. Remove coupling guard (131). Disconnect coupling (42).

### **WARNING**

To lift motor, a hoist or suitable lifting device must be used.

2. Attach hoist to motor. Remove capscrews (607), freeing motor from motor bracket (71). Hoist motor and motor coupling half away from pump and rest on plywood, heavy cardboard or other adequate durable surface.
3. Attach lifting straps and eyebolts to base (23). Take to a suitable work area.
4. Remove bolts (611). Remove suction cover (9) with o-ring (89A).

### **NOTE**

Replace used o-rings, seals, and bearings with new o-rings, seals, and bearings.

5. Remove impeller bolt (26) and impeller washer (28).
6. Remove impeller (2) and impeller key (32).
7. Remove shaft sleeve (14), if equipped. Refer to sectional drawings, Optional Sleeve detail.

### **CAUTION**

Do NOT pry composite parts. Damage may occur to composite parts if they are struck with force, pounded with a metal object or pried.

8. Remove nuts (617) with bolts (604) and washers (654).

### **WARNING**

To lift bearing housing, use a hoist or suitable lifting device.

9. Remove bearing housing (19) assembly and shaft (6).
10. Inspect throttle bushing (63) in accordance with paragraph C, procedure 5 and Table 2 of this section. Do NOT remove throttle bushing (63) and o-ring (89X), unless necessary.

### **NOTE**

Do NOT disassemble column (101) from casing (1) or base (23), unless necessary.

11. Remove coupling half on pump side and remove coupling key (46).
12. Remove nuts (616) and bolts (609) to remove motor bracket (71).
13. Remove capscrews (608) from bearing cartridge (37) and tighten jacking capscrews (610) to remove shaft (6) and bearings (16) and (18) from bearing housing.
14. Remove snap ring (176) from bearing cartridge (37).
15. Remove bearing cartridge (37) from shaft assembly.
16. Uncrimp bearing lockwasher (69) and remove bearing locknut (22) and bearing lockwasher (69).
17. Press bearings (16) and (18) off shaft (6).

### **ASSEMBLY**

Assemble the pumping unit using the following procedures:

### **NOTE**

Carver recommends that grease seals (47), o-ring (89), and locking devices with a nylock feature be replaced with new if disturbed from position.

Carver recommends that bearings (16 and 18) be replaced if removed from shaft.

1. Install oil seal (47) in bearing frame (19). Place snap ring (176) on shaft (6) between two bearing seats.
2. Install radial bearing (16) and thrust bearing (18) on shaft (6). Bearings (16 and 18) may

be pressed onto shaft (6) or heated so they will slide onto shaft (6). Pack bearings half full with grease. Refer to section VI, paragraph D for proper grease type. Install bearing lockwasher (69) and bearing locknut (22). Crimp lockwasher (69).

3. Install bearing cartridge (37) over thrust bearing (18). Install snap ring (176) in bearing cartridge (37).
4. Set wet end of shaft (6) in through bearing frame end of bearing frame (19). Install shaft (6), bearings (16 and 18), and bearing cartridge (37) through bearing frame (19).
5. Secure bearing cartridge (37) to bearing frame (19) with capscrews (608) and jacking screw (610). Tighten capscrews (608) by hand only, leaving a 0.25-inch gap between bearing cartridge (37) and bearing frame (19) so impeller vanes will not be damaged when rotating element is installed in casing (1).
6. Install coupling key (46) in keyway of shaft (6). Install pump coupling (42) half.
7. Install motor bracket (71) and secure to bearing frame (19) with nuts (616) on capscrews (609).
8. Install grease seal (47) in column (101).
9. If throttle bushing (63) was removed, press new throttle bushing (63) and o-ring (89X) into column (101).
10. Install bearing housing assembly into column (101).
11. Attach assembled bearing frame (19) to column (101) with bolt (604), washer (654), and nut (617).
12. Install shaft sleeve (14), if equipped. Refer to sectional drawings, Optional Sleeve detail.

### **CAUTION**

Use removable thread locker when installing impeller bolt.

13. Install impeller key (32) in shaft (6). Install impeller (2) and impeller washer (28). Secure to end of shaft (6) with new bolt (26). Do not use old bolt as impeller damage could result.

### **WARNING**

To lift rotating element, a hoist or suitable lifting device must be used.

14. Install new o-ring (89A) onto suction cover (9).
15. Install suction cover (9) onto casing (1).
16. Adjust impeller in accordance with paragraph C of this section.
17. Connect coupling. Attach coupling guard.
18. Reconnect wiring to motor. Remove tags from electrical power supply. Unlock and connect electrical power supply to motor.

19. Remove tags from system valves. Open all system valves.
20. Start pumping unit in accordance with section V, paragraphs A and B.

**GVT, 1520 FRAME (Top Pullout)** (Refer to Figure 4 and Table 7)

### **DISASSEMBLY**

Disassemble the pumping unit using the following procedure:

1. Remove coupling guard (131). Disconnect coupling (42).

#### **WARNING**

To lift motor, a hoist or suitable lifting device must be used.

2. Attach hoist to motor. Remove capscrews (607), freeing motor from bearing frame (19). Hoist motor and motor coupling half away from pump and rest on plywood or heavy cardboard.
3. Screw lifting eye into the tapped hole located at coupling end of pump shaft or place a strap through bearing frame (19). Attach hoisting equipment to lifting eye or strap.
4. Remove nuts (615) from studs (630) separating outer column (53) from column plate (101).

#### **WARNING**

To lift rotating element, a hoist or suitable lifting device must be used.

5. Hoist rotating element and move to a suitable work area.

#### **CAUTION**

Do NOT pry composite parts. Damage may occur to composite parts if they are struck with force, pounded with a metal object or pried.

6. Remove impeller capscrew (26) from end of shaft (6). Remove impeller washer (28). Pull impeller (2) from shaft (6). Remove impeller key (32) from either impeller (2) or shaft (6).
7. Remove shaft sleeve (14), if equipped. Refer to sectional drawings, Optional Sleeve detail.
8. Remove nut (617). Remove bolt (604) and washer (654) to remove bearing frame (19) from column (101).
9. Inspect throttle bushing (63) in accordance with paragraph C, procedure 5 and Table 2 of this section. Do NOT remove throttle bushing (63) and o-ring (89X), unless necessary.

10. Remove pump coupling (42) half. Remove coupling key (46) from either coupling (42) or shaft (6).
11. Loosen setscrew (667) to remove bearing cap (37).
12. Remove bearings (16) and (18) with shaft (6) assembly from bearing housing (19).
13. Remove outer snap ring (176).
14. Remove bearings (16) and (18) from shaft (6).
15. Remove bearing spring (449).

### **ASSEMBLY**

Assemble the pumping unit using the following procedures:

#### **NOTE**

Carver recommends that grease seals (47), o-ring (89), and locking devices with a nylock feature be replaced with new if disturbed from position.

Carver recommends that bearings (16 and 18) be replaced if removed from shaft.

1. Install bearing spring (449) onto shaft (6) between two bearing seats.
2. Install upper bearing (16) and lower bearing (18) onto shaft (6). Bearings may be pressed onto shaft or heated so they slide onto shaft. Pack bearings half full of grease. Refer to section VI, paragraph D for proper grease type.
3. Install outer snap ring (176).
4. Install shaft and bearings into bearing housing (19).
5. Install new grease seal (47) in bearing cap and grease seal (47A) in column (101).
6. Install bearing cap (37) and hand tighten.
7. Install coupling key (46) and slide coupling half onto pump.
8. If throttle bushing (63) was removed, press new throttle bushing (63) and o-ring (89X) into column (101).

#### **WARNING**

To lift bearing housing, use a hoist or suitable lifting device.

9. Install bearing housing assembly and shaft (6) into column (101) and secure with bolts (604), washers (654), and nuts (617).
10. Install shaft sleeve (14), if equipped. Refer to sectional drawings, Optional Sleeve detail.



### **CAUTION**

Use removable thread locker when installing impeller bolt.

11. Install impeller key (32) and impeller (2) and secure with washer (28) and bolt (26).
12. Install lifting eye into end tap or place a strap through bearing housing (19). Attach hoisting equipment to lifting eye or strap and return rotating element to pump.
13. Slowly lower rotating element into casing (1). Do not force rotating element. If installed correctly, it will slide in easily. Secure inner column (101) to outer column (53) with nuts (615) and washers (656) on studs (630).
14. Detach hoisting equipment and remove lifting eye from end tap.

### **WARNING**

To lift motor, a hoist or suitable lifting device must be used.

15. Attach hoist and move motor, and motor coupling half into place on bearing housing (19). Secure motor to the bearing housing (19) with capscrews (607).
16. Adjust impeller clearance in accordance with paragraph C of this section.
17. Connect coupling. Attach coupling guard.
18. Reconnect wiring to motor. Remove tags from electrical power supply. Unlock and connect electrical power supply to motor.
19. Remove tags from system valves. Open all system valves.
20. Start pumping unit in accordance with section V, paragraphs A and B.

**GVT, 1530/1540 FRAME (Top Pullout)** (Refer to Figure 5, Figure 6, and Table 7)

### **DISASSEMBLY**

Disassemble the pumping unit using the following procedure:

1. Remove coupling guard (131). Disconnect coupling (42).

### **WARNING**

To lift motor, a hoist or suitable lifting device must be used.

2. Attach hoist to motor. Remove capscrews (607), freeing motor from motor bracket (71). Hoist motor and motor coupling half away from pump and rest on plywood or heavy cardboard.

### **WARNING**

To lift bearing/column assembly, a hoist or suitable lifting device must be used.

3. Screw lifting eye into the tapped hole located at coupling end of pump shaft or place a strap through motor bracket (71). Attach hoisting equipment to lifting eye or strap.
4. Remove nuts (615) from studs (630) separating outer column (53) from column plate (101).

### **WARNING**

To lift rotating element, a hoist or suitable lifting device must be used.

5. Hoist rotating element and move to a suitable work area.

### **CAUTION**

Do NOT pry composite parts. Damage may occur to composite parts if they are struck with force, pounded with a metal object or pried.

6. Remove impeller capscrew (26) from end of shaft (6). Remove impeller washer (28). Pull impeller (2) from shaft (6). Remove impeller key (32) from either impeller (2) or shaft (6).
7. Remove shaft sleeve (14), if equipped. Refer to sectional drawings, Optional Sleeve detail.
8. Remove nuts (616) and capscrews (609) separating motor bracket (71) from bearing frame (19).
9. Remove pump coupling (42) half. Remove coupling key (46) from either coupling (42) or shaft (6).
10. Remove nuts (617) with bolts (604) and washers (654).
11. Inspect throttle bushing (63) in accordance with paragraph C, procedure 5 and Table 2 of this section. Do NOT remove throttle bushing (63) and o-ring (89X), unless necessary.
12. Remove capscrews (608) separating bearing cartridge (37) from bearing frame (19). Use forcing capscrews (610) to loosen bearing cartridge (37) from bearing frame (19).
13. Pull shaft (6) out through coupling end of the bearing frame (19). The bearings (16 and 18) and bearing cartridge (37) will remain on shaft (6).
14. Remove snap ring (176) from bearing cartridge (37). Let snap ring (176) rest on shaft. Pull bearing cartridge (37) from bearing (18).
15. Uncrimp bearing lockwasher (69) and remove bearing locknut (22) and lockwasher (69).

16. Remove thrust bearing (18) from coupling end of shaft (6). Remove radial bearing (16) from shaft (6). Remove snap ring (176) from shaft (6).

## ASSEMBLY

Assemble the pumping unit using the following procedures:

### NOTE

Carver recommends that grease seals (47), o-ring (89), and locking devices with a nylock feature be replaced with new if disturbed from position.

Carver recommends that bearings (16 and 18) be replaced if removed from shaft.

1. Install oil seal (47) in bearing frame (19). Place snap ring (176) on shaft (6) between two bearing seats.
2. Install radial bearing (16) and thrust bearing (18) on shaft (6). Bearings (16 and 18) may be pressed onto shaft (6) or heated so they will slide onto shaft (6). Pack bearings half full with grease. Refer to section VI, paragraph D for proper grease type. Install bearing lockwasher (69) and bearing locknut (22). Crimp lockwasher (69).
3. Install bearing cartridge (37) over thrust bearing (18). Install snap ring (176) in bearing cartridge (37).
4. Set wet end of shaft (6) in through bearing frame end of bearing frame (19). Install shaft (6), bearings (16 and 18), and bearing cartridge (37) through bearing frame (19).
5. Secure bearing cartridge (37) to bearing frame (19) with capscrews (608) and jacking screw (610). Tighten capscrews (608) by hand only, leaving a 0.25-inch gap between bearing cartridge (37) and bearing frame (19) so impeller vanes will not be damaged when rotating element is installed in casing (1).
6. Install coupling key (46) in keyway of shaft (6). Install pump coupling (42) half.
7. Install motor bracket (71) and secure to bearing frame (19) with nuts (616) on capscrews (609).
8. Install grease seal (47) in column (101).
9. If throttle bushing (63) was removed, press new throttle bushing (63) and o-ring (89X) into column (101).

### WARNING

To lift rotating element, a hoist or suitable lifting device must be used.

10. Install bearing housing assembly into column (101).
11. Attach assembled bearing frame (19) to

column (101) with bolt (604), washer (654), and nut (617).

12. Install shaft sleeve (14), if equipped. Refer to sectional drawings, Optional Sleeve detail.

### CAUTION

Use removable thread locker when installing impeller bolt.

13. Install impeller key (32) in shaft (6). Install impeller (2) and impeller washer (28). Secure to end of shaft (6) with new bolt (26). Do not use old bolt as impeller damage could result.
14. Install lifting eye into end tap or place a strap through motor bracket (71). Attach hoisting equipment to lifting eye or strap and return rotating element to pump.
15. Slowly lower rotating element into casing (1). Do not force rotating element. If installed correctly, it will slide in easily. Secure inner column (101) to outer column (53) with nuts (615) and washers (656) on studs (630).
16. Detach hoisting equipment and remove lifting eye from end tap.

### WARNING

To lift motor, a hoist or suitable lifting device must be used.

17. Attach hoist and move motor, and motor coupling half into place on motor bracket (71). Secure motor to the motor bracket (71) with capscrews (607).
18. Adjust impeller in accordance with paragraph C of this section.
19. Connect coupling. Attach coupling guard.
20. Reconnect wiring to motor. Remove tags from electrical power supply. Unlock and connect electrical power supply to motor.
21. Remove tags from system valves. Open all system valves.
22. Start pumping unit in accordance with section V, paragraphs A and B.

## B. PARTS INSPECTION.

1. All parts should be thoroughly cleaned or replaced with new ones, if necessary. All sealing faces should be perfectly clean. It is recommended that oil seals (47), o-ring (89), and locking devices with a nylock feature be replaced with new if disturbed from position.
2. Inspect bearings (16 and 18) from damage. Damaged bearings must be replaced. If bearings are removed from shaft, it is recommended that bearings be replaced. If bearing replacement is not possible and bearings are in good condition bearings should be cleaned and lubricated according to section VI, paragraph D. Provide

- appropriate protection for bearings until time of usage.
3. Inspect for bent shaft (6) and replace shaft (6), if necessary. Shaft threads should be in good condition. Bearing seat must be in perfect condition.
  4. If the impeller (2) shows excessive wear due to abrasion or corrosion and performance cannot be restored, it must be replaced.
  5. Inspect the inside diameter of throttle bushing (63). The inside diameter of the throttle bushing (63) will increase with wear. The throttle bushing requires replacement if the inside diameter is more than 0.020 inch out of round or .005 inch oversized. Refer to Table 2 for maximum diameter of throttle bushing.

6. Inspect and replace any defective grease fittings.
7. On an enclosed impeller pump, check the clearance as follows:
  - a. Measure outside diameter of front impeller (2) hub in three places. Refer to Table 3, Enclosed Impeller Clearance.
  - b. Measure inside diameter of suction cover (9) or wear ring (7), if equipped, in three places.
  - c. If difference between high reading of inside diameter of the suction cover (9) or wear ring (7), if equipped, and low reading of outside diameter of impeller (2) hub exceeds double the maximum clearances given in Table 3, replace suction cover (9) and impeller (2) or wear ring (7), if equipped. To replace wear ring (7), refer to paragraph D of this section.

**Table 2. Throttle Bushing Dimensions**

| Frame Size | Maximum Diameter | Minimum Diameter |
|------------|------------------|------------------|
| 1520       | 1.277 inches     | 1.275 inches     |
| 1530       | 1.777 inches     | 1.775 inches     |
| 1540       | 2.163 inches     | 2.160 inches     |

**Table 3. Enclosed Impeller Clearance**

| Ordering Code | Impeller Size      | Wear Ring Size     | FACTORY STANDARD DIAMETRIC CLEARANCE |          |
|---------------|--------------------|--------------------|--------------------------------------|----------|
|               |                    |                    | MINIMUM                              | MAXIMUM  |
| DA            | 2.750/2.749 inches | 2.762/2.760 inches | .010 in.                             | .013 in. |
| DB            | 4.724/4.722 inches | 4.740/4.742 inches | .016 in.                             | .020 in. |
| DC            | 4.724/4.722 inches | 4.740/4.742 inches | .016 in.                             | .020 in. |
| DD            | 4.724/4.722 inches | 4.740/4.742 inches | .016 in.                             | .020 in. |
| DE            | 7.937/7.935 inches | 7.956/7.958 inches | .019 in.                             | .023 in. |
| EA            | 3.337/3.335 inches | 3.347/3.349 inches | .010 in.                             | .014 in. |
| EB            | 4.124/4.122 inches | 4.140/4.142 inches | .016 in.                             | .020 in. |
| EC            | 4.715/4.713 inches | 4.731/4.733 inches | .016 in.                             | .020 in. |
| ED            | 5.500/5.498 inches | 5.517/5.518 inches | .017 in.                             | .020 in. |
| EE            | 5.894/5.892 inches | 5.912/5.914 inches | .018 in.                             | .020 in. |
| EF            | 6.681/6.679 inches | 6.698/6.700 inches | .017 in.                             | .021 in. |
| EG            | 7.862/7.860 inches | 7.881/7.882 inches | .019 in.                             | .022 in. |

**C. ADJUSTING IMPELLER CLEARANCE ON PUMP EQUIPPED WITH SEMI-OPEN IMPELLER.**

To adjust impeller clearance on a pump equipped with a **semi-open impeller, 1520 frame**, use the following procedure:

1. Stop pump according to section V, paragraph C. Lock out and tag the power to the driver. Remove coupling guard.
2. Disconnect coupling (42).
3. Loosen setscrew (667).
4. Once pump is in the vertical position, loosen bearing cap (37) until impeller rubs on suction head.
5. Place a dial indicator on the end of shaft (6).
6. Tighten bearing cap (37) until indicator reads between .010 and .015 inch.
7. To hold setting, evenly tighten setscrew (667) while watching indicator.
8. Turn shaft (6) by hand to ensure impeller is not rubbing.

To adjust impeller clearance on a pump equipped with a **semi-open impeller, 1530/1540 frame**, use the following procedure:

1. Stop pump according to section V, paragraph C. Lock out and tag the power to the driver. Remove coupling guard.
2. Disconnect coupling (42).
3. Once the pump is in the vertical position, loosen capscrews (608) from bearing cartridge (37). Loosen forcing capscrews (610) from bearing cartridge (37) until impeller rubs suction cover.
4. Place a dial indicator on the end of shaft (6).
5. Tighten forcing capscrews (610) evenly until indicator reads between 0.010 and 0.015 inch.
6. To hold setting, evenly tighten capscrews (608) while watching indicator.
7. Turn shaft (6) by hand to ensure impeller is not rubbing.

**NOTE**

Shaft setting should be checked again after pump is installed and before restarting pump. Clearance should be between 0.010 inch and 0.015 inch over original measurement of gap.

8. Reconnect coupling.
9. Replace coupling guard.
10. Start pump according to section V, paragraphs A and B.

To adjust impeller clearance on a pump equipped with an **enclosed impeller, 1520 frame**, use the following information:

If the impeller bumps casing (1), adjust bearing cap (37) upward or downward until the rotating element turns freely.

To adjust impeller clearance on a pump equipped with an **enclosed impeller, 1530/1540 frame**, use the following information:

If pump is equipped with an enclosed impeller and impeller (2) bumps casing (1) when rotating element is installed, use the following procedure: to adjust impeller clearance:

- a. Measure the gap between the bearing cartridge (37) and bearing frame (19). Check to make sure coupling gap is not binding.
- b. Tighten forcing capscrews (610) half a turn, until no rubbing occurs.
- c. Evenly tighten capscrews (608).

**D. REPLACEMENT OF OPTIONAL WEAR RING ON PUMP EQUIPPED WITH ENCLOSED IMPELLER.**

If your pump is equipped with an enclosed impeller, it may have an optional, replaceable wear ring (7) in the suction cover (9) or casing (1). If your pump is equipped with the optional wear ring (7), use the following instructions and figure 7 for wear ring replacement.

**NOTE**

Stainless fitted and all iron pumps do not use a wear ring. Stainless steel pumps use a wear ring.

The clearance between the wear ring (7) and impeller (2) hub will increase with wear. Internal leakage will result and pump performance will decrease.

**Table 4. Impeller/Wear Ring Matching Materials**

| IMPELLER MATERIAL                              | WEAR RING MATERIAL  |
|--|---------------------|
| All Iron & Stainless Fitted<br>Stainless Steel | Cast Iron<br>17-4PH |

To replace the wear ring, follow the disassembly procedures in paragraphs A and B of this section to the point where the casing or suction cover has been removed and the wear ring is accessible. Once the wear ring is accessible, use the following procedures:

1. Remove wear ring (7) from suction cover (9). This can best be accomplished on a lathe.
2. Inspect impeller (2) hub for damage.
3. Press new wear ring (7) into suction cover (9). Beveled edge of wear ring (7) is installed toward impeller (2).

4. Place impeller (2) on an arbor and mount between centers in a lathe or a grinder. Indicate back of impeller (2) hub to within 0.002 T.I.R. maximum to be sure arbor and impeller (2) are running square.
5. Turn wearing surface of impeller (2) until a 63 RMS or better finish is obtained.
6. Measure outside diameter of front impeller (2) hub and record the value.
7. Mount suction cover (9) with new wear ring (7) installed in a lathe. Indicate male rabbet to within 0.002 T.I.R. maximum.
8. Bore wear ring (7) to within specified tolerance (listed in Table 3) over recorded size of outside diameter of front impeller (2) hub.

**CAUTION**

Use removable thread locker when installing impeller capscrew.

**Table 5. Recommended Spare Parts**

| Item No. | Qty. | Description                           |
|----------|------|---------------------------------------|
| 2        | 1    | Impeller                              |
| 7        | 1    | Undersized Wear ring<br>(if equipped) |
| 14       | 1    | Shaft sleeve (if equipped)            |
| 16       | 1    | Radial bearing                        |
| 18       | 1    | Thrust bearing                        |
| 22       | 1    | Bearing locknut                       |
| 26       | 1    | Impeller capscrew                     |
| 28       | 1    | Impeller washer                       |
| 32       | 1    | Impeller key                          |
| 46       | 1    | Coupling key                          |
| 47       | 1    | Grease seal<br>(column)               |
|          | 1    | (bearing frame)                       |
| 63       | 1    | Throttle bushing                      |
| 69       | 1    | Bearing lockwasher                    |
| 89A      | 1    | O-ring                                |
| 89X      | 1    | O-ring                                |

**IX. PARTS LIST AND FIGURES.**

Refer to Table 6 for the parts list of the GVC pump.  
Refer to Table 7 for the parts list of the GVT pump.  
For location of all parts referenced on the list, refer to the sectional drawings.

**Table 6. Pump Parts List for GVC 1520 and GVC 1530/1540 frame**

| Item No. | Part Name                  | Item No. | Part Name      |
|----------|----------------------------|----------|----------------|
| 1        | Casing                     | 101      | Inner column   |
| 2        | Impeller                   | 131      | Coupling guard |
| 6        | Shaft                      | 176      | Snap ring      |
| 7        | Wear ring (if equipped)    | 422      | Plug           |
| 9        | Suction cover              | 423      | Plug           |
| 14       | Shaft sleeve (if equipped) | 449      | Bearing spring |
| 16       | Upper (radial) bearing     | 600      | Bolt           |
| 18       | Lower (thrust) bearing     | 602      | Bolt           |
| 19       | Bearing housing            | 604      | Bolt           |
| 22       | Bearing locknut            | 606      | Bolt           |
| 23       | Base                       | 607      | Bolt           |
| 26       | Impeller bolt              | 608      | Capscrew       |
| 28       | Impeller washer            | 609      | Nut            |
| 32       | Impeller key               | 610      | Bolt           |
| 37       | Bearing cap (cartridge)    | 611      | Capscrew       |
| 42       | Coupling                   | 612      | Nut            |
| 46       | Coupling key               | 616      | Nut            |
| 47       | Oil seal                   | 617      | Nut            |
| 47A      | Vapor seal                 | 618      | Nut            |
| 63       | Throttle bushing           | 635      | Washer         |
| 69       | Bearing lockwasher         | 652      | Washer         |
| 71       | Motor bracket              | 654      | Washer         |
| 76       | Grease zerk                | 655      | Washer         |
| 89A      | O-ring (suction cover)     | 657      | Washer         |
| 89X      | O-ring (throttle bushing)  | 667      | Setscrew       |

**Table 7. Pump Parts List for GVT 1520 and GVT 1530/1540 frame**

| Item No. | Part Name                  | Item No. | Part Name      |
|----------|----------------------------|----------|----------------|
| 1        | Casing                     | 101      | Inner column   |
| 2        | Impeller                   | 131      | Coupling guard |
| 6        | Shaft                      | 176      | Retaining ring |
| 7        | Wear ring (if equipped)    | 422      | Plug           |
| 9        | Suction cover              | 423      | Plug           |
| 14       | Shaft sleeve (if equipped) | 600      | Bolt           |
| 16       | Upper bearing              | 602      | Bolt           |
| 18       | Lower bearing              | 604      | Bolt           |
| 19       | Bearing housing            | 606      | Bolt           |
| 22       | Impeller locknut           | 607      | Capscrew       |
| 23       | Base                       | 608      | Capscrew       |
| 26       | Impeller bolt              | 609      | Capscrew       |
| 28       | Impeller washer            | 610      | Bolt           |
| 32       | Impeller key               | 611      | Capscrew       |
| 37       | Bearing cap                | 612      | Nut            |
| 42       | Coupling                   | 615      | Nut            |
| 46       | Coupling key               | 616      | Nut            |
| 47       | Oil seal (bearing cap)     | 617      | Nut            |
| 47A      | Vapor seal                 | 618      | Nut            |
| 53       | Column (outer)             | 630      | Stud           |
| 63       | Throttle bushing           | 635      | Washer         |
| 69       | Bearing lockwasher         | 652      | Washer         |
| 71       | Motor bracket              | 654      | Washer         |
| 76       | Grease zerk                | 655      | Washer         |
| 89A      | O-ring (suction cover)     | 656      | Washer         |
| 89X      | O-ring (throttle bushing)  | 657      | Washer         |
|          |                            | 667      | Setscrew       |

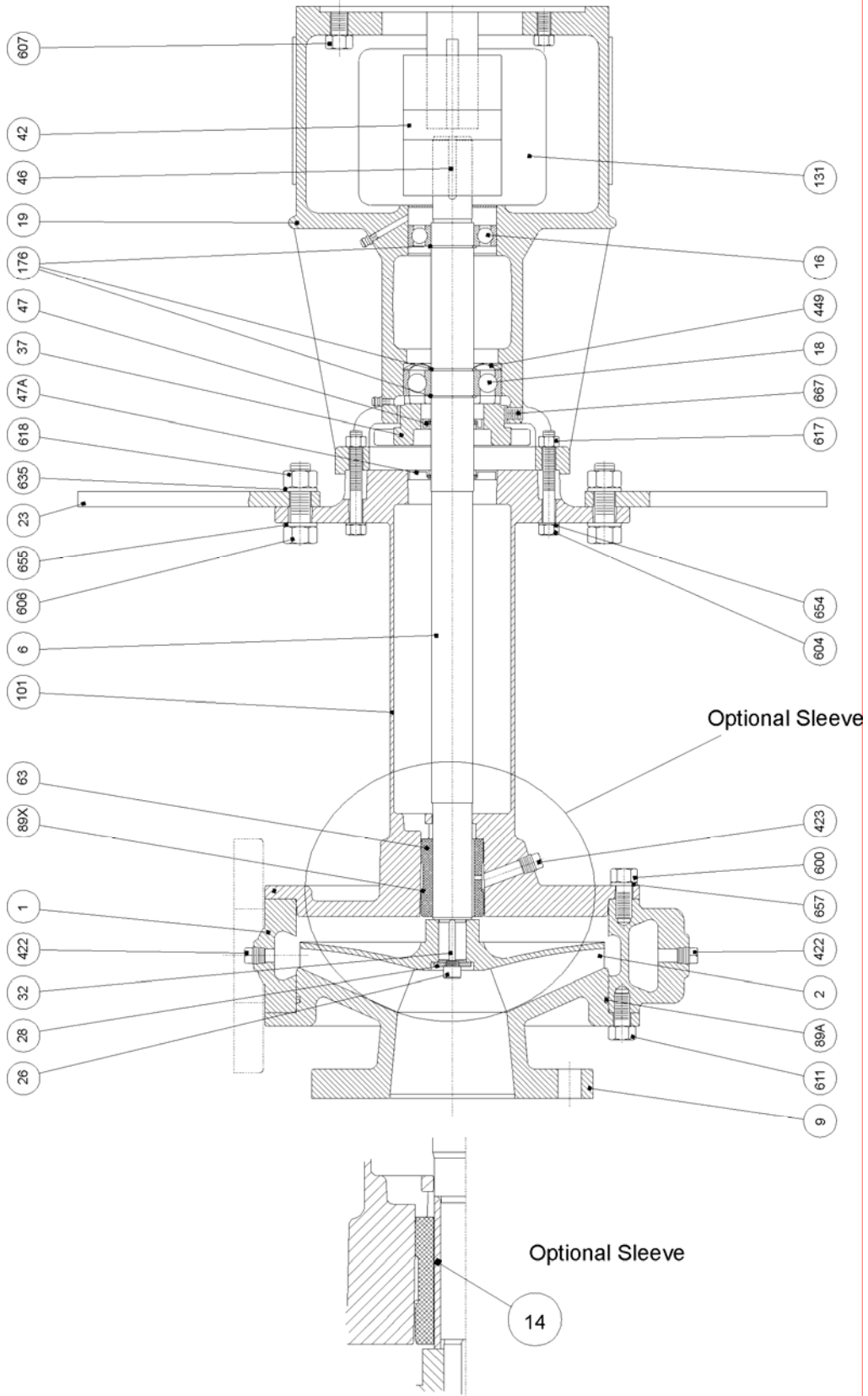

Figure 1. GVC (1520 Frame) Sectional Drawing

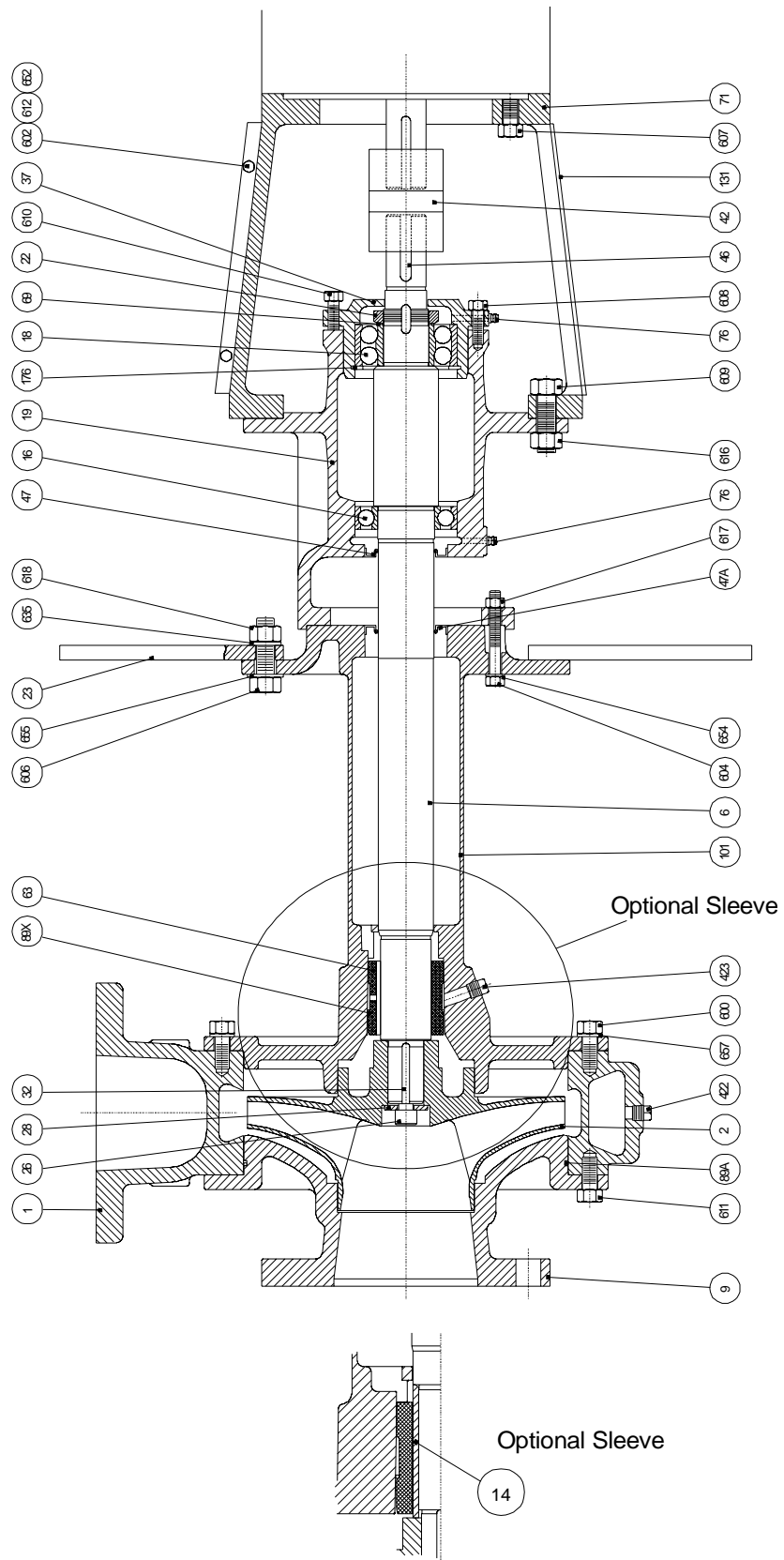

Figure 2. GVC (1530 Frame) Sectional Drawing



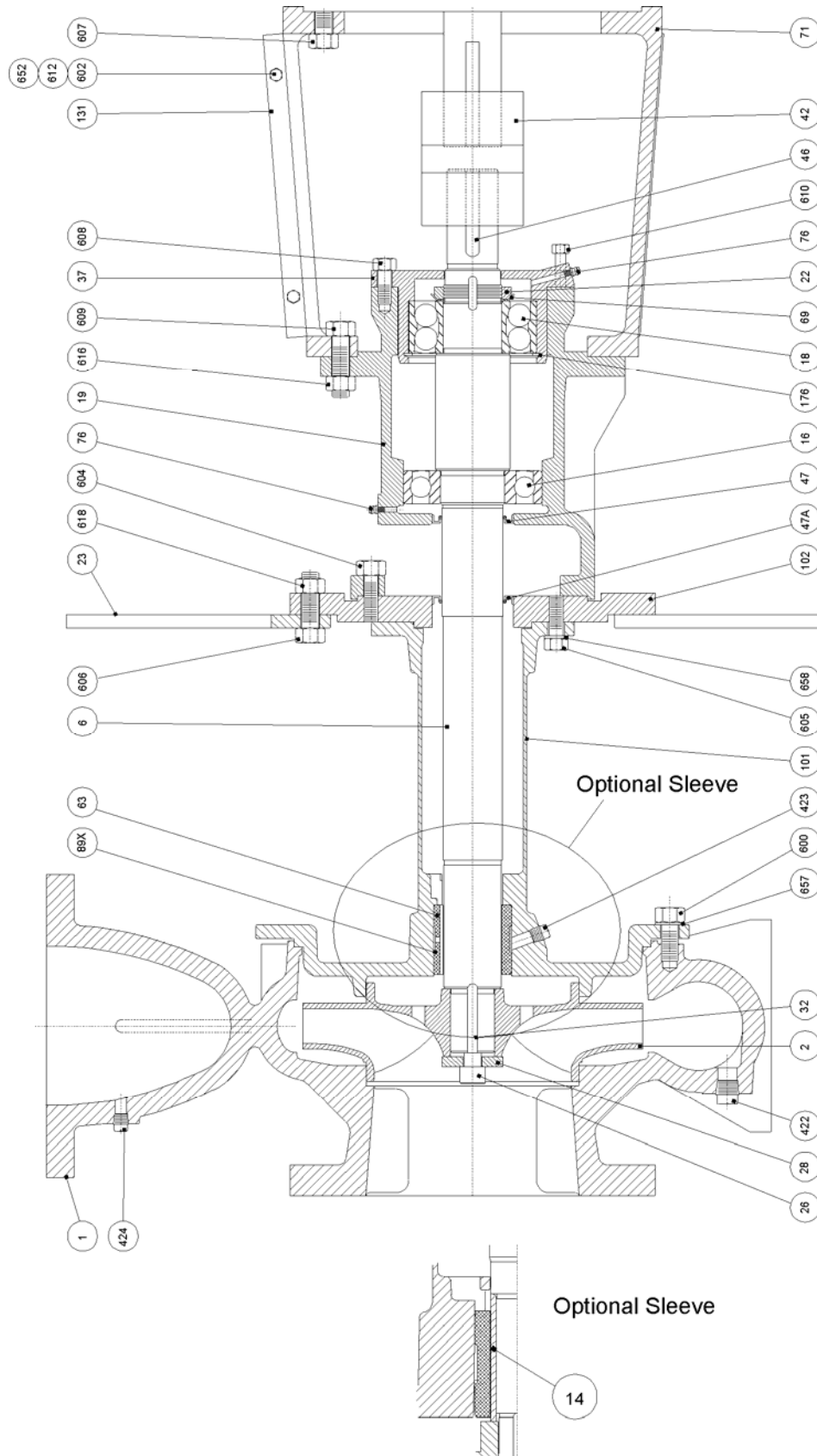

Figure 3. GVC (1540 Frame) Sectional Drawing

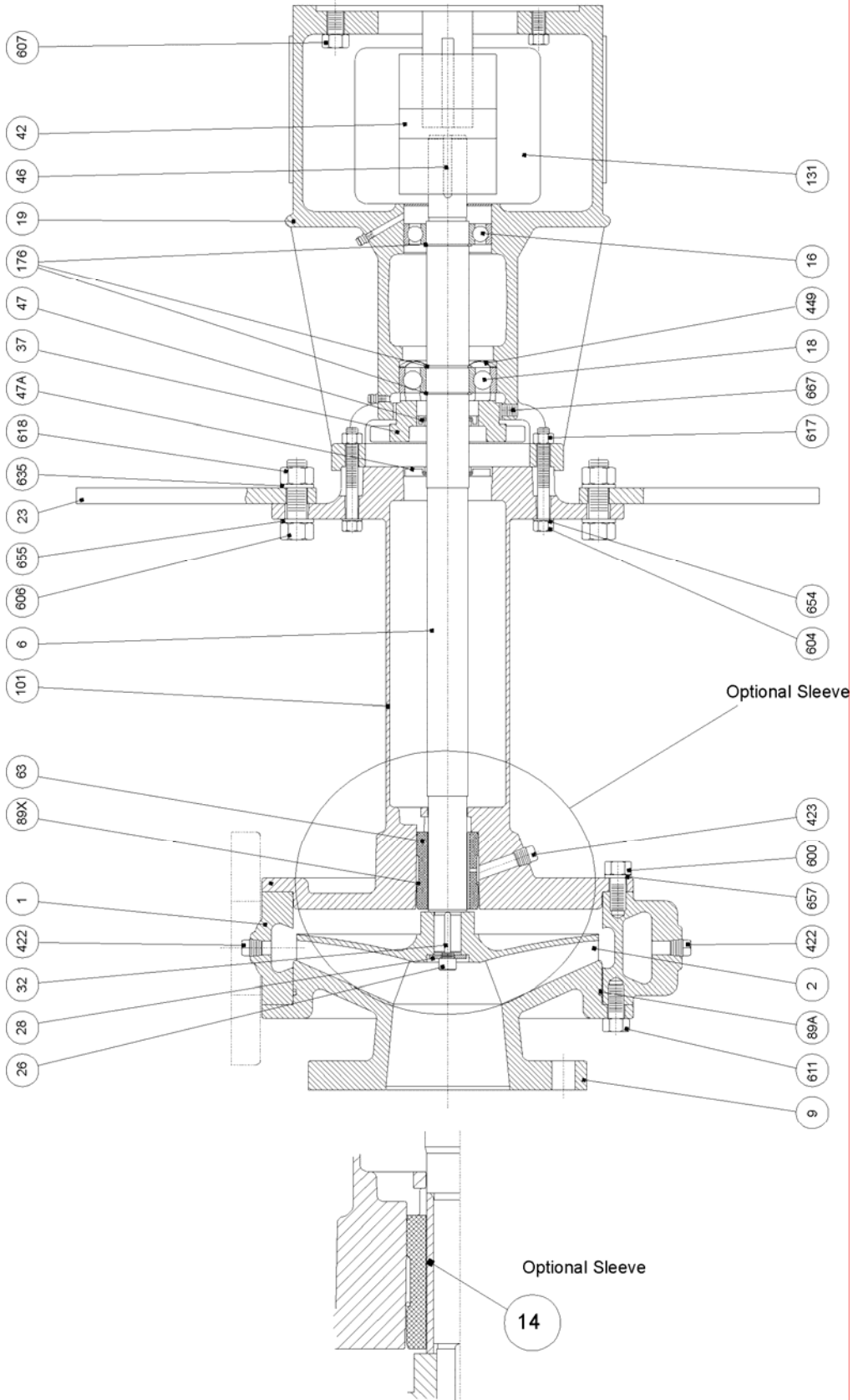

Figure 4. GVT (1520 Frame) Sectional Drawing

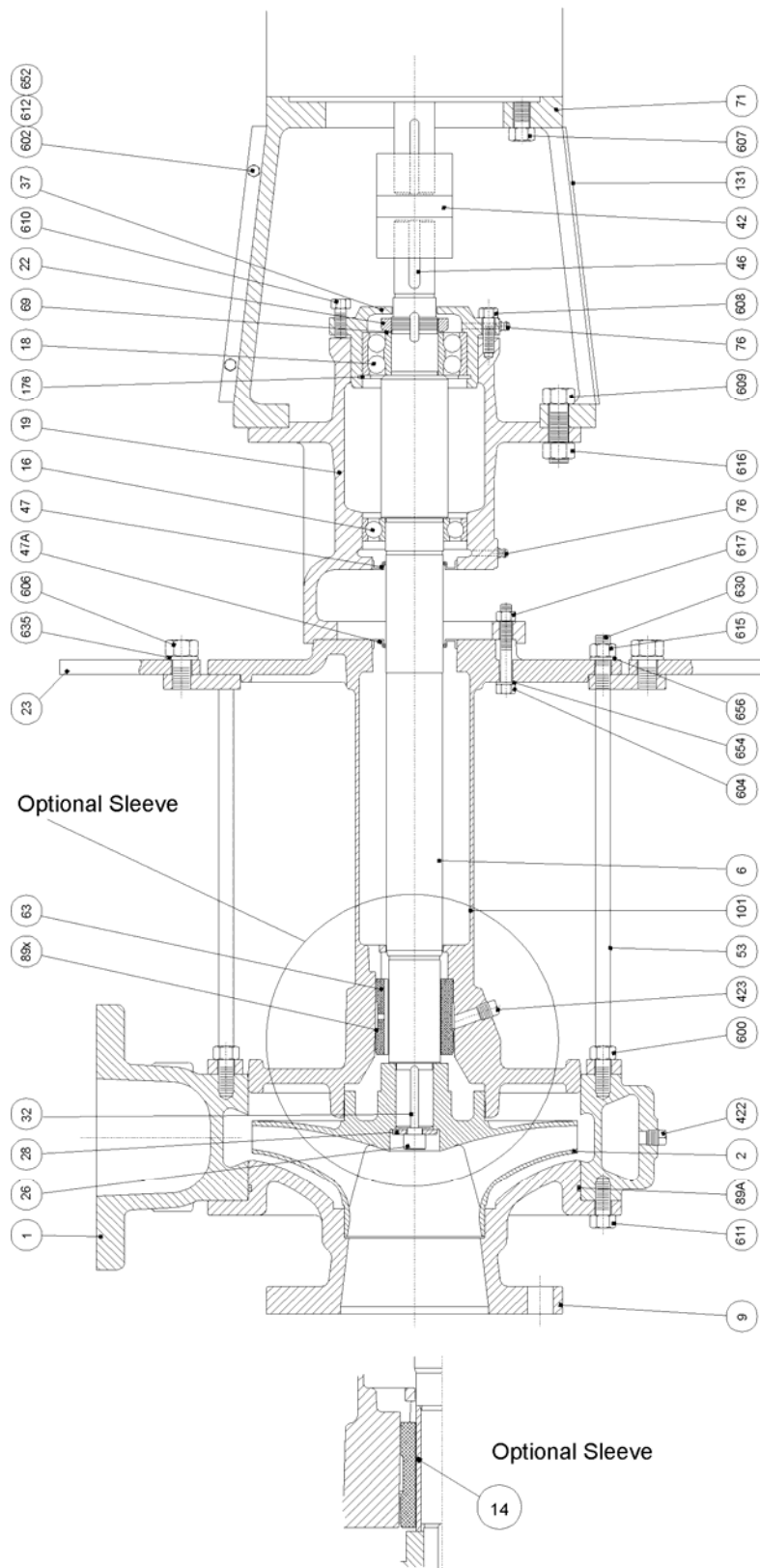

Figure 5. GVT (1530 Frame) Sectional Drawing

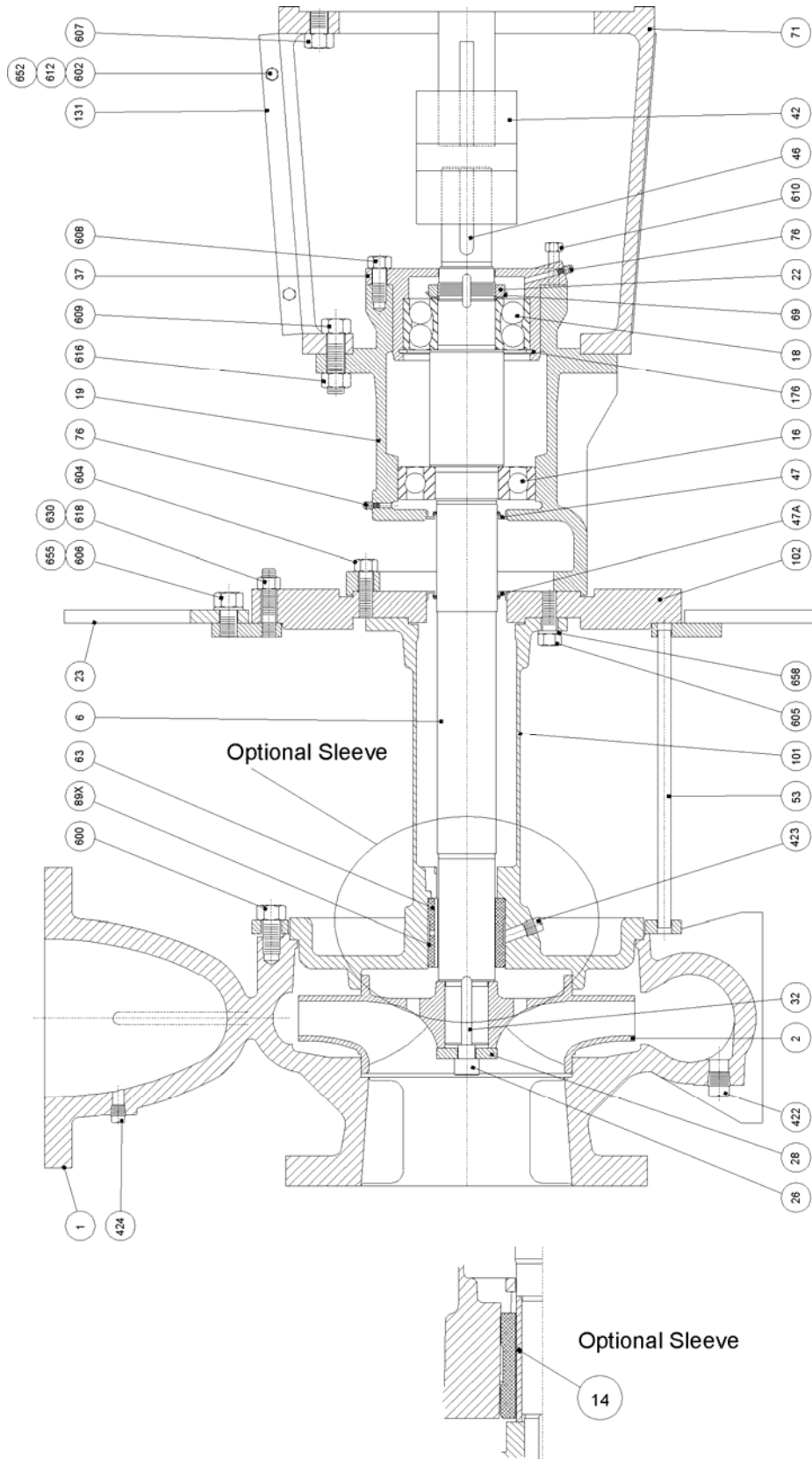

Figure 6. GVT (1540 Frame) Sectional Drawing

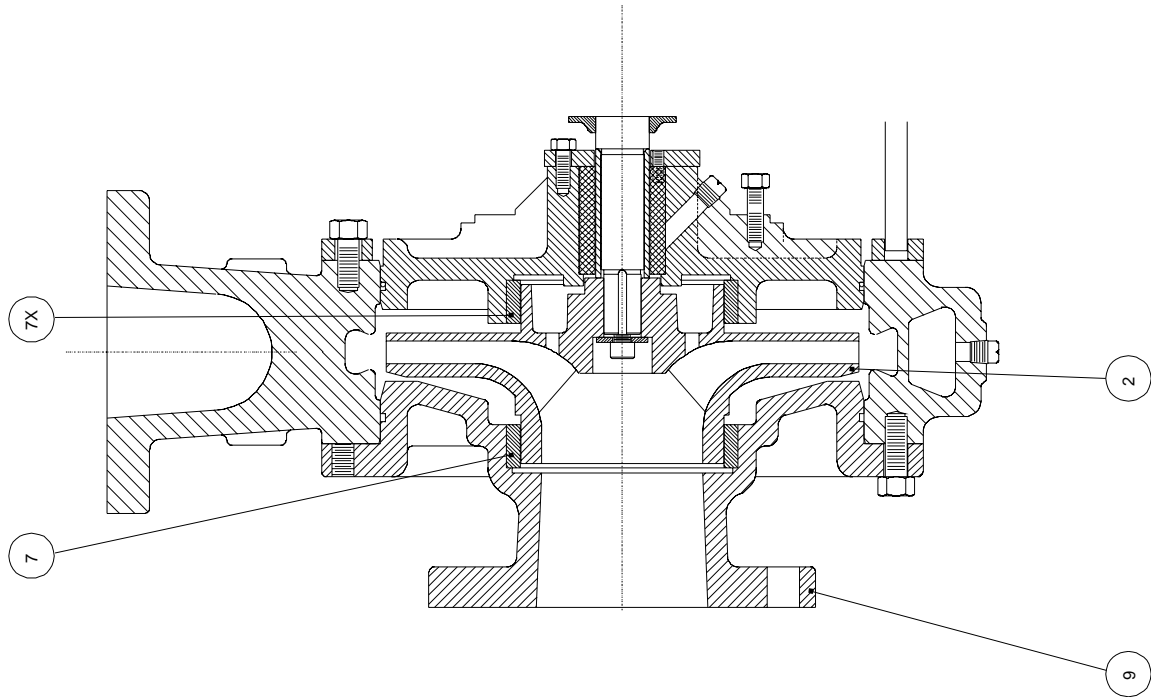

Figure 7. Optional Wear Ring



**Carver Pump Company**

2415 Park Avenue • Muscatine, IA 52761  
563.263.3410 • Fax: 563.262.0510

[www.carverpump.com](http://www.carverpump.com)

**May 3, 2005**