



Camlok Clamps



3
4
5
6-7
8-9
10
11
12
13
14
15
16
17
18
19
20
21
22
23
24
25
26
27

CLAMP SECTION CRITERIA
MINIMUM LOAD CRITERIA
CAMLOK LIFTING PAD DESIGN
CZ VERTICAL PLATE CLAMP
CY & CX HINGED PLATE CLAMPS
LJ NON MARKING CLAMP
TTR GIRDER CLAMP
CH HORIZONTAL PLATE CLAMP
THK HORIZONTAL PLATE CLAMP
CP PILE PINCHING CLAMP
HGC HAND GRIP CLAMP
THS HORIZONTAL PLATE CLAMP
TSH SCREW CLAMP
HG VERTICAL PLATE CLAMP
CG GIRDER TURING CLAMP
TTG HORIZONTAL GIRDER CLAMP
BTG GROUNDWORKS
SCREWLOK & SC BEAM CLAMP
CTP BEAM CLAMP
CLB LIFTING LUG
CLB LIFTING LUG SAFETY
92 SERIES & C2 SPARE PARTS
CY & CX SPARE PARTS

CAMLOK CLAMPS, part of the extensive offering from **CM Rigging Products**, provides secure lifts for a variety of loads including:

- Structural Steel Plate
- Stainless Steel
- Iron
- Aluminum
- Girders/Beams
- Sheet Plates
- Steel Piles
- Rolled Steel Joists
- Manhole Pipes
- Shipping Containers

Camlok Clamps are designed in accordance with ISO9002, and the company is accredited by BSI (British standards) and is a member of the Lifting Equipment Engineers Association (LEEAA).

Known for a robust, versatile product line, Camlok is one of the premier below-the-hook lifting devices offered through CM Rigging Products. Clamps are available as stand-alone units or may be part of complete lifting systems that include Herc-Alloy® slings, Lodelok™ attachments, spreader beams, hoists, jib cranes, and many related items. Whether your needs call for a single clamp for a unique application, a wide variety of clamps to address a multitude of needs, or a complete lifting system, count on the decades of engineering and application-driven experience provided by CM Rigging Products.

For specific requests for Camlok clamps or any need for rigging products, contact our customer service department at 800-888-0985 or sales@cmworks.com.

For **EFFICIENT**, **RELIABLE**, and **SECURE** operation of a lifting clamp, the selection of the correct clamp for the job is of paramount importance:

Vertical Plate Clamps, Type CZ92:

The CZ92 range of clamps has been designed as a general purpose plate handling clamp for the steel fabrication industry. A clamp can lift steel plates from the horizontal to the vertical and over again through 180°. The necessary grip required to lift a plate is achieved by increasing the force applied to the clamp from the lifting sling by a system of links. The gripping force is therefore proportional to the load lifted and self-actuating. The greater the load applied to the clamp, the greater the force. To initiate the self-actuating force a spring is incorporated into the clamp to give an initial bite on the material.

The clamps can be used on most types and grades of steel up to a surface hardness of 300 Brinell (32HRC). The clamp is also suitable for certain grades of aluminum sheet and brass. The clamp is not suitable for steel over 300 Brinell (32HRC), stainless steel, lead, certain grades of copper and materials over 120°C or 250°F surface temperature.

The working load limit of the clamp should be as close as possible to the actual load to be lifted. This ensures the clamp is working at maximum efficiency. When the efficiency is reduced, the clamp suffers wear, thus will reduce the operational life of the clamp. The maximum jaw capacity of the clamp should also be as close as possible to the plate thickness being lifted. The spring will be stretched to its maximum and will be providing the maximum amount of initial grip to the lift.

Excessive wear and a reduction in working life can be caused if a clamp is continuously used to lift the same thickness material. Clamps used for this type of application must have special inspection procedures applied. The one or two teeth of the moving jaw where the wear is concentrated must be inspected regularly. Where this type of application exists, rotation of the lifting clamps throughout the factory will increase the operational life of the clamp or specialist clamps can be manufactured.

Applications where the majority of lifting is thin light sheets will be best served by the selection of a narrow throat clamp. The pad side of a narrow throat clamp is moved closer to the moving jaw, thus increases the initial grip of the clamp by causing the spring to be stretched.

Applications where the plate is thick, but the load is small, are best suited to larger versions of a clamp. Moving the pad side of the clamp away from the moving jaw creates a large version clamp. This has the advantage that the clamp has a jaw and mechanism best suited to the load applied and therefore is working at maximum efficiency.

Applications where the load is of hardened steel are not suitable for a clamp with teeth. A solution to this application must be formed from a range of non marking clamps.

MINIMUM LOAD CRITERIA

The maximum load imposed on a device determines the structure and size of a plate clamp. The manufacturer will design the internal components of the clamp to cope with these forces in consideration to the expected mechanical losses of the system.

Most Camlok clamps use sharp teeth to bite into the plate being lifted. Once a clamp has bitten into the plate, it effectively becomes one with the plate and therefore the plate can be safely lifted. The design of the clamp is such that the load applied to the hook ring is magnified through a system of links to give a high gripping force to push the jaw teeth into the lifted plate. This gripping force is directly proportional to the load applied and self actuating (i.e. the higher the load applied, the higher the gripping force). This is known as the primary action. A secondary force generated by movement in the lifted plate supplements the primary gripping force, if the plate starts to slip from the clamp, the moving jaw is turned with the plate and the cam shape of the jaw increases the gripping force.

Plate lifting clamps are simple machines. Like all machines with mechanisms they are subjected to naturally occurring phenomenon that reduce efficiency. The phenomenons include;

- A** Friction between moving parts. This will reduce the forces transmitted through the mechanism.
- B** Inertia of the components. This will assert a degree of drag into the system slowing the reaction to changing inputs.

The system of links and pivots in a plate clamp are simple, lightweight, and move over a small distance when in operation. The bearings in a plate clamp are generally simple "metal on metal" type, have large forces acting through them, and have poor lubrication. Therefore, the friction loss can be significant if the clamp is poorly maintained and suffering wear.

The mechanism of the plate clamp is not static during operation but the movements are small. The inertia and friction of the mechanism can have a significant effect on the performance of the clamp when lifting material from the horizontal to the vertical position. The imposed load on the clamp fluctuates from 50% of the load being lifted to zero and then to 100% at the "top dead center" position. (The point when the center of gravity of the plate passes over the pivot point contact on the floor and is then lifted clear.)

The amount a tooth penetrates into the lifted plate is dependent on a number of factors:

- A** The gripping force
- B** The hardness of the plate being lifted.
- C** The shaped of the clamp tooth

In simple terms, a tooth will penetrate into the material until the gripping force divided by the projected area of the tooth contact equals the indent stress of the material.

CAMLOK LIFTING PAD DESIGN

Unlike round pads on the market, Camlok uses a wide spacing or square pad layout. The wide spacing and layout of the teeth on the Camlok square pad help prevent the plate and clamp pivoting during lifting. This protects the straight teeth on the moving jaw. All the teeth on the square pad can be considered to lift the load therefore maximizing efficiency. The pads are marked with the maximum material hardness.

Round Pads

On round pads the gripping force must push all the teeth into the material. However only the top and bottom quarter of the pad can be considered to effectively lift the load, thus reducing the efficiency of the pad. There is no resistance to pivoting and straight teeth on the jaw suffer rotational stress and wear.

Resistance to pivoting

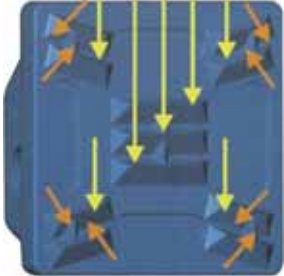

LOAD

SQUARE VS ROUND

	SQUARE	ROUND
Pivoting Resistance	Excellent	Poor
Teeth wear	Excellent	Average
Full surface contact	Excellent	Poor
Load Distribution	Excellent	Poor
Pad Bolt Stress	Low	High

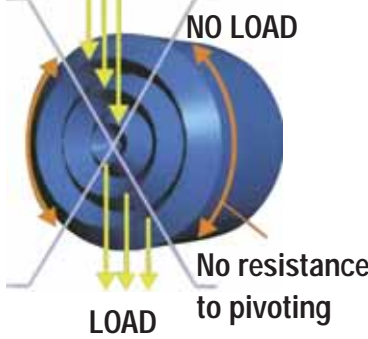

LOAD

NO LOAD

No resistance to pivoting

LOAD

Camlok Jaw

The prevention of load twisting by the wide pad and teeth layout on the Camlok clamp eliminates any twisting or pivoting load on the jaws. This helps prevent any unnecessary wear or damage on the teeth.

The force of the load on the Camlok Clamp is distributed through the pad directly to the clamp housing. This means there is no load stress on the pad bolts and reduces the possibility of pad bolt failure during lifting.

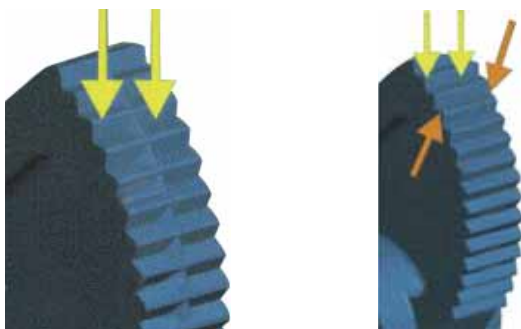

When the load on round pads twists, the narrow jaw resists it. This places very high loads on the edge of the jaw. The jaw is not designed to sustain this pivoting load.

CZ SERIES Vertical Plate Clamps

The **CZ & 92 series** of plate clamps can be used on all hot rolled structural steel plates and sections up to a surface hardness of 300 Brinell (32HRc). They can be used to lift plate from the horizontal to vertical position and vice versa through 180°. This series is fitted with a hold open and lock closed device. To initiate the self actuating force, a spring is incorporated into the clamp to give an initial bite on the material. If the plate should start to slip during lifting, the cam shape of the jaw turns with the material and increases the gripping force.

The cam handle has been ergonomically designed with a flat surface to allow ease of operation while wearing protective gloves. The cam handle connects to the cam via a robust square drive.

Unlike other clamps, Camlok plate clamps are designed with a sloping slot, which increases the grip on the load when the clamp is in the horizontal position.



- Used on all hot rolled structural steel plates and sections up to a surface hardness of 300 Brinell (32HRc)
- Available in capacities of ½ ton up to 33 tons
- Jaw capacities available up to maximum of 5-1/8"
- Lifts plates from horizontal to vertical position and vice versa through 180°
- Clamp has serrated teeth and will mark plate
- Select a clamp with a working load limit as close as possible to the actual load being lifted and the maximum jaw capacity should be as close as possible to the plate thickness
- Repair centers available to service your products
- Replacement parts available for clamps

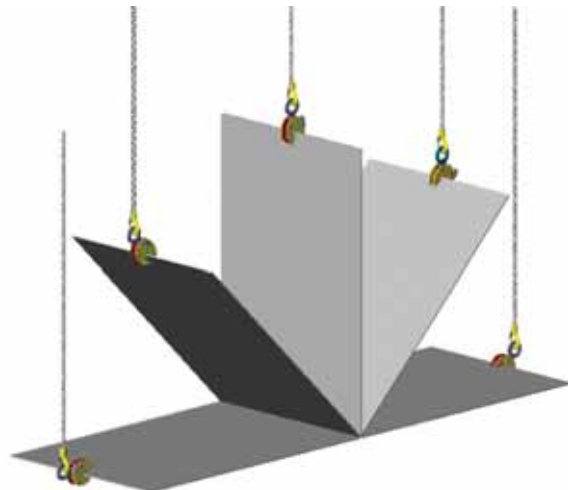

CZ SERIES Vertical Plate Clamps



Things to Remember

- Weight of plate to lift
- Hardness of plate to lift
- Type of material to lift
- Position of plate to lift
- Can plate be marked, is a non marking clamp required?

DON'Ts

- **DO NOT** side load clamp more than 15° - use type CY or CX clamp for side loading
- **DO NOT** lift plates with a temperature of 120°C/ or 250°F
- **DO NOT** use to lift stainless steel, lead, and copper. For stainless steel plate, use LJ or HG Clamp.
- **DO NOT** use on a double, triple, or quad sling. When using two clamps to lift a steel plate, a lifting beam must be used between the two clamps, so the clamps operate in a vertical position. Use a CY or CX clamp for slings with more than one leg.

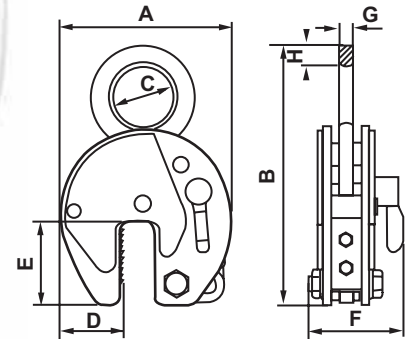

CZ SPECIFICATIONS

Model	Working Load Limit		Jaw Capacity	Dimensions								Weight
	Min	Max		A	B	C	D	E	F	G	H	
	lb.	lb.	in.	in.	in.	in.	in.	in.	in.	in.	in.	lb.
CZ920.5	120	1,100	0 to 5/8	3.898	7.677	1.142	1.299	1.850	1.969	1.890	0.433	3.3
CZ921.5	350	3,300	0 to 3/4	4.961	8.858	1.969	1.929	2.756	3.228	2.165	0.472	6.6
CZ922	450	4,400	0 to 1-1/4	7.559	12.283	3.150	2.953	3.780	3.937	3.189	0.787	17.6
CZ923	675	6,600	0 to 1-1/4	7.559	12.283	3.150	2.953	3.780	3.937	3.189	1.181	22.0
CZ924	1,100	8,800	0 to 1-1/4	7.756	14.606	3.150	2.677	3.661	5.079	0.787	1.181	26.5
CZ924/L*	1,100	8,800	1-1/8 to 2-3/8	8.976	15.354	3.150	2.677	3.661	5.079	0.787	1.181	39.7
CZ926	1,600	13,200	0 to 2	11.535	19.055	3.504	3.740	5.630	5.079	0.984	1.378	46.3
CZ928	2,150	17,600	0 to 2	11.535	19.370	3.504	3.740	5.630	5.079	0.984	1.654	57.3
CZ928/L*	2,150	17,600	2 to 4	14.252	20.630	3.504	4.488	5.630	5.079	0.984	1.654	70.5
CZ9210	3,350	22,000	0 to 2	11.535	21.457	4.331	3.740	5.630	5.472	0.984	1.772	66.1
CZ9210/L	3,350	22,000	2 to 4	14.252	21.457	4.331	4.488	5.630	5.472	0.984	1.772	81.6
CZ9215*	6,650	33,000	0 to 2	14.173	24.134	5.118	4.921	6.378	8.031	1.772	2.165	165.3
CZ9215/L*	6,650	33,000	2 to 4	18.110	26.693	5.118	6.890	6.378	8.031	1.772	2.165	194.0
CZ9220*	8,850	44,000	0 to 2-1/2	18.189	29.724	5.118	6.496	8.268	9.252	1.772	2.559	271.2
CZ9220/L*	8,850	44,000	2-1/2 to 5	22.047	31.693	5.118	7.677	8.268	9.252	1.772	2.559	299.8
CZ9230*	13,250	66,000	0 to 2-1/2	18.189	28.819	2.362	6.496	8.268	11.614	2.559	-	429.9

* Products available upon request

CY & CX SERIES Hinged Plate Clamps

The CY series of plate clamps can be used on all structural steel plates up to surface hardness of 300 Brinell. These clamps are designed to be used with two leg chain sling for lifting longer plates. With the swiveling hook ring, the CY series of clamps can be fitted to a steel plate in any position. These clamps can turn a plate from the horizontal to vertical lift over the edge. Sufficient clamping of the load is achieved by this special shape of the hook ring.

The CX series clamps are a more robust heavy duty model of the CY clamp. The CX clamp has a reinforced plate at the top of the mouth, and a heavy duty hook ring. The CX clamp is more suitable for turning vertically racked plates.



CY SERIES

- Used on all hot rolled structural steel plates and sections up to a surface hardness of 300 Brinell (32HRc)
- Available in capacities of 1 ton up to 10 tons
- Jaw capacities available up to maximum of 4"
- Lifts plates from horizontal to vertical position and vice versa through 180°
- Clamps can be used with 2 leg slings
- Clamp has serrated teeth and will mark plate
- Select a clamp with a working load limit as close as possible to the actual load being lifted and the maximum jaw capacity should be as close as possible to the plate thickness
- Repair centers available to service your products
- Replacement parts available for clamps



CX SERIES

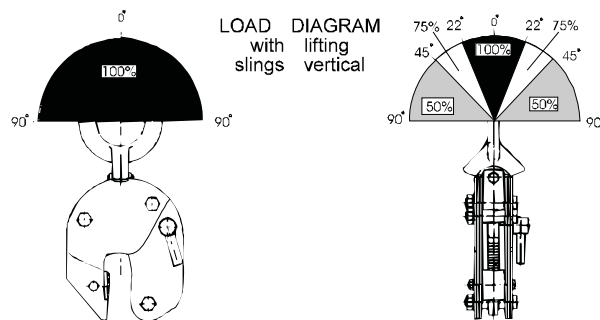

Loads weighing the maximum W.L.L. may be lifted and turned through 180° in the plane of the clamp.

The clamp can be used on edge and side loads can be lifted with a reduction in the W.L.L. as shown in the diagram.

DON'Ts

- **DO NOT** lift loads less than 20% of Working Load Limit of clamp
- **DO NOT** lift plates with a temperature of 120°C/ or 250°F
- **DO NOT** use to lift stainless steel, lead, and copper. For stainless steel plate, use LJ or HG Clamp.

CY & CX SERIES Hinged Plate Clamps

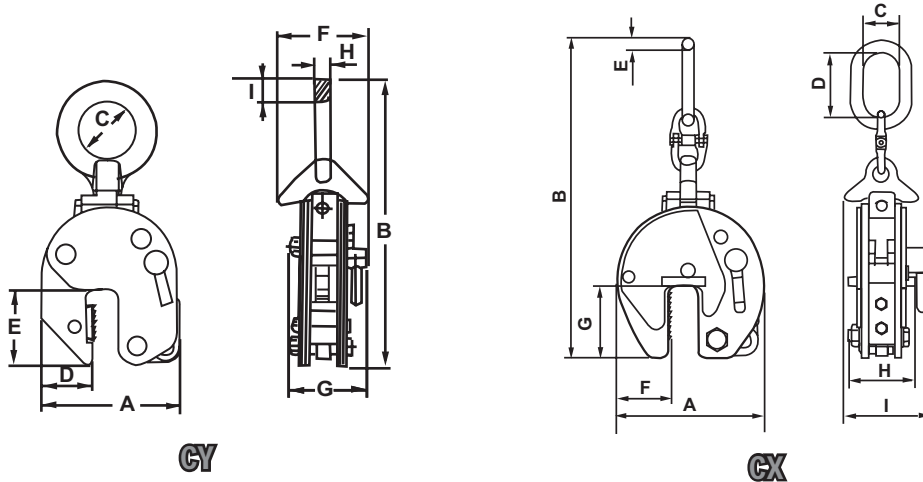

GY SPECIFICATIONS

Model	Working Load Limit		Jaw Capacity	Dimensions									Weight
	Min	Max		A	B	C	D	E	F	G	H	I	
	lb.	lb.	in.	in.	in.	in.	in.	in.	in.	in.	in.	in.	lb.
CY1	450	2,200	0 to 3/4	4.961	10.630	1.969	1.929	2.756	3.740	2.480	0.472	0.906	10.1
CY2	900	4,400	0 to 1-1/4	7.559	15.039	3.150	2.953	3.780	5.197	3.622	0.787	1.181	26.5
CY3	1,350	6,600	0 to 1-1/4	7.559	15.039	3.150	2.953	3.780	5.197	3.622	0.787	1.181	30.9

CX SPECIFICATIONS

Model	Working Load Limit		Jaw Capacity	Dimensions									Weight
	Min	Max		A	B	C	D	E	F	G	H	I	
	lb.	lb.	in.	in.	in.	in.	in.	in.	in.	in.	in.	in.	lb.
CX3	1,000	6,600	0 to 1-1/4	7.756	20.276	2.638	5.433	0.748	2.677	3.661	3.189	4.331	26.5
CX6	2,650	13,200	0 to 2	11.496	29.016	3.740	6.929	1.102	3.740	5.630	5.394	7.402	83.8
CX6/L*	2,650	13,200	2 to 4	14.449	30.906	3.858	7.087	1.102	4.528	5.630	5.315	7.402	105.8
CX8*	3,550	17,600	0 to 2	11.496	29.016	3.858	6.929	1.102	3.740	5.630	5.354	8.268	86.0
CX8/L*	3,550	17,600	2 to 4	14.449	30.906	3.858	7.087	1.102	4.528	5.630	5.354	8.268	112.4
CX10*	4,400	22,000	0 to 2	14.173	35.551	4.331	7.677	1.299	4.921	6.378	6.693	8.780	134.5
CX10/L*	4,400	22,000	2 to 4	17.559	36.260	4.409	7.677	1.299	6.614	6.378	6.693	8.780	167.5

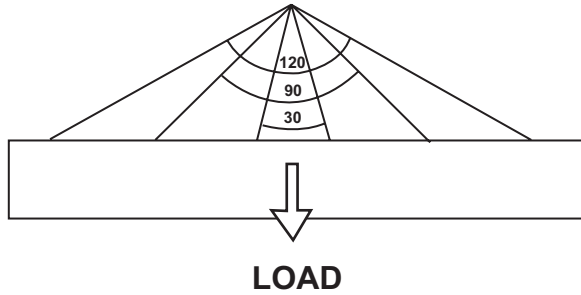

Angle	Model Code		
	CY1	CY2	CY3
Imperial			
degrees	lb.	lb.	lb.
0-30	4,400	8,800	13,200
30-90	2,200	4,400	6,600
90-120	1,100	2,200	3,300

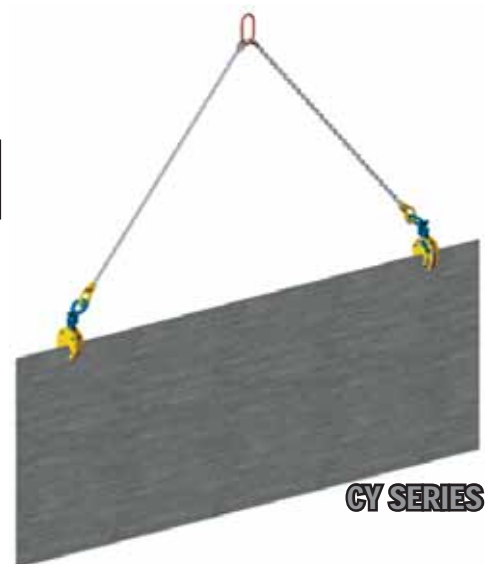

LJ SERIES Non Marking Clamps

The **Camlok LJ series** of plate clamps can be used to lift and turn all structural steel plates including stainless steel, iron, and aluminum without marking or damaging the surface. The clamp may not be suitable for lifting highly polished plates where the polish process may leave lubricating compounds. The performance on the leather jaws is not affected by standing water so the clamp can be used with submerged plasma cutting machines. The LJ clamp is suitable for surface hardness greater than 300 Brinell (32HRc).



- The LJ clamp can be used on all structural plates, stainless steel, iron, timber, and aluminum without marring or damaging the surface. Lifts plates from the horizontal to vertical position and vice versa through 180°.
- Suitable for steel with a surface hardness above 300 Brinell (32HRc)
- Available in capacities up to 1.5 tons
- The LJ clamp can be used on thin plates. Minimum load will not affect the LJ clamps as they do not have teeth for bite. However some load is required to combat friction in the clamp. Extra care must be taken when lifting plates in the lower 20% of their rated capacity. Thin plates are best lifted with the fixed jaw on top when performing a horizontal to vertical lift.
- Repair centers available to service your products
- Replacement parts available for clamp

DOs & DON'Ts

- **DO NOT** use the clamp on plates with surface contamination (dirt, grease, scale, etc...). Minimize dirt and dust on the surface to be lifted. Pads can tolerate surface water on the plate but shall not be submerged under water.
- **DO NOT** use on smooth polished surfaces. The polished surfaces leave behind lubricating compounds. The leather pads need to surround the irregularities in the surface to grip the load effectively.
- **DO** clean the leather pads regularly, clean in water only and use a brass suede brush to rough up the surface.
- **DO NOT** use solvents to clean the jaw lining as this may affect the bond between the surface material and the metal of the jaw.
- **DO** inspect the clamp before each use. Make sure the pads are clean. If pads are cut or worn, or can not be cleaned, take clamp out of service and replace pads. When in doubt, remove clamp from service.

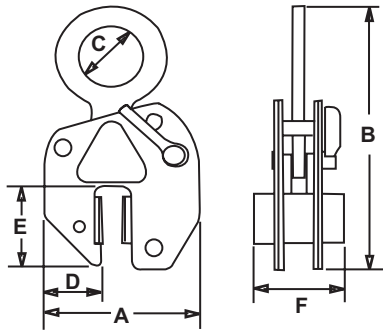

SPECIFICATIONS

Model	Working Load Limit		Jaw Capacity	Dimensions						Weight
	Min	Max		A	B	C	D	E	F	
	lb.	lb.		in.	in.	in.	in.	in.	in.	
LJ0.5	60	1,100	0 to 3/8	5.000	7.874	2.165	2.047	2.717	2.992	7.7
LJ1.5	400	3,300	0 to 3/4	8.465	13.583	3.346	2.953	5.315	4.646	26.5

TTR SERIES Girder Clamps

The **TTR clamps** can be used on girders and rolled steel joists up to a surface hardness of 300 Brinell (32HRc). This range of clamps has been developed for handling structural beams with the flange in a vertical position, or "H" position. Girders can be lifted and stacked horizontally. The hook rings are designed to be as near to the center of gravity as possible, resulting in a near horizontal lift. For short beams a single clamp can be used. For longer beams, two clamps should be used in combination with a lifting beam. Various sizes and lifting capacities are available. The TTR is a versatile tool for transporting girders and joists. This clamp is fitted with a cam operated locking mechanism.



- Used to lift and transport structural beams up to a surface hardness of 300 Brinell (32HRc) with the flanges in the up right position
- Available in capacities up to 3 tons
- Jaw capacities available up to maximum of 1-1/8"
- Short beams may be lifted with a single clamp, longer beams should use 2 clamps and a spreader beam
- Repair centers available to service your products
- Replacement parts available for clamps
- No special tools required for repairs

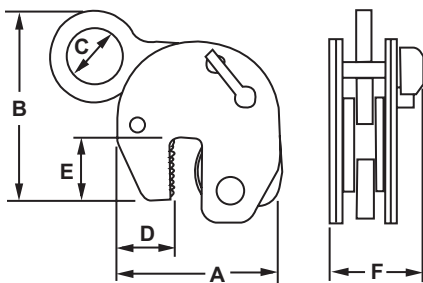

DON'Ts

- **DO NOT** lift plates with a temperature of 120°C/ or 250°F
- **DO NOT** use to lift stainless steel, lead and copper

SPECIFICATIONS

Model	Working Load Limit		Flange	Dimensions						Weight
	Min	Max		A	B	C	D	E	F	
	lb.	lb.		in.	in.	in.	in.	in.	in.	
TTRO.75	90	1,600	1/4 to 5/8	5.375	7.500	2.000	1.750	2.375	3.500	7.7
TTR1.5	350	3,300	1/4 to 1	7.500	10.625	2.625	2.625	3.000	4.875	22.0
TTR3*	700	6,600	1/4 to 1	8.250	9.875	3.500	2.625	3.375	5.000	26.5

* Products available upon request

CH SERIES Horizontal Plate Clamps

The **CH clamps** are sold in pairs and can be used on all types of materials in plate form, providing the plate can withstand the forces imposed. Standard CH clamps are supplied with smooth jaws. The clamps are suitable for lifting one plate at a time, or bundles of plates provided the plates are the same width, have straight square sides, and are thicker than 10% of the maximum jaw capacity of the clamp. CH clamps should never be side loaded. The smooth jaws can be replaced with serrated hardened steel teeth and used on material up to 300 Brinell (32HRc).



- CH clamps must be used in pairs
- Available in pair capacities of 1 ton up to 10 tons
- Jaw capacities available up to maximum of 6"
- CH clamps have smooth teeth and can be used on all types of material
- A single pair of CH clamps can be used with a 2 leg sling
- CH clamps can be furnished with serrated teeth
- When serrated teeth are used, maximum hardness of material to lift should not exceed 300 Brinell
- Integral shackle on the CH clamp designed to accept relevant size chain sling hook
- CH clamps can be designed to suit any load or plate thickness
- Repair centers available to service your products
- Replacement parts available for clamps

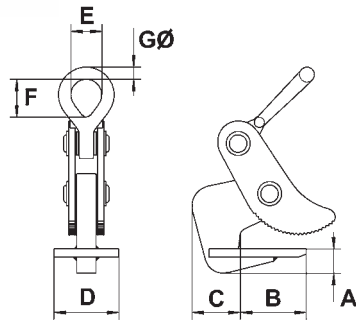

DON'Ts

- DO NOT use CH clamps with for side loading

SPECIFICATIONS

Model	Working Load Limit (per pair)	Jaw Capacity	Dimensions							Weight (per pair)
			A	B	C	D	E	F	G	
	lb.	in.	in.	in.	in.	in.	in.	in.	in.	lb.
CH1	2,200	1/4 to 1-1/4	1.181	3.228	2.362	3.937	1.260	1.732	0.512	13.2
CH2	4,400	1/4 to 1-1/4	1.181	3.228	2.362	3.937	1.969	2.874	0.709	24.3
CH2/L	4,400	3/4 to 2	1.181	3.228	2.362	3.937	1.969	2.874	0.709	26.5
CH4	8,800	1/4 to 1-1/4	1.575	4.409	3.150	3.937	2.520	3.622	0.984	37.5
CH4/L	8,800	2 to 4	1.575	4.409	3.150	3.937	2.520	3.622	0.984	50.7
CH6	13,200	1/4 to 3	2.165	6.772	3.937	5.118	3.543	5.118	1.378	101.4
CH6/L	13,200	2 to 5	2.165	6.772	3.937	5.118	3.543	5.118	1.378	123.5
CH8	17,600	1/4 to 3	2.165	6.772	4.134	5.118	3.543	5.118	1.378	116.8
CH8/L	17,600	2 to 5	2.165	6.772	4.134	5.118	3.543	5.118	1.378	132.3
CH10	22,000	1/4 to 4	2.559	8.465	4.724	5.906	4.488	5.118	1.378	209.4
CH10/L	22,000	2 to 6	2.559	8.465	4.724	5.906	4.488	5.118	1.378	238.1
HH8*	17,600	1/4 to 2	2.165	6.614	4.134	5.118	4.134	5.118	3.543	46.3
HH8/L	17,600	2 to 4	2.165	6.614	4.134	5.118	3.543	4.488	1.378	61.7

* Products available upon request

THK SERIES Horizontal Plate Clamps

The **THK Series Clamp** has a jaw that pivots in the reverse direction to our normal horizontal clamps and is designed to lift and handle thin sheet plate that tends to sag when being lifted. The reverse jaw feature ensures that the grip of the clamp increases the more the plate deflects under its own self weight. Clamps are used in pairs with a two legged chain sling. Two pairs of clamps supported from a lifting beam must be used when handling long plates. Single plates only can be lifted.



- THK clamps must be used in pairs
- Available in pair capacities of 3/4 ton up to 9 tons
- Jaw capacities available up to maximum of 2-1/4"
- Clamp has serrated teeth and will mark plate
- A single pair of THK clamps can be used with a 2 leg sling
- CH clamps can be furnished with serrated teeth
- Maximum hardness of material to lift should not exceed 300 Brinell (32HRc)
- Repair centers available to service your products
- Replacement parts available for clamps

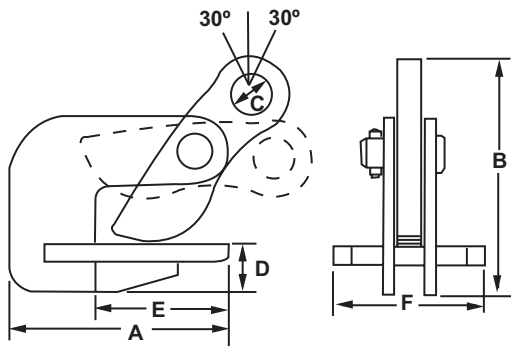

DON'Ts

- **DO NOT** use THK clamps with 3 or 4 leg slings, use a spreader beam

SPECIFICATIONS

Model	Working Load Limit (per pair)		Plate	Dimensions						Weight (per pair)
	Min	Max		A	B	C	D	E	F	
	lb.	lb.		in.	in.	in.	in.	in.	in.	
THK0.75	90	1,600	0 to 1	4.625	5.375	0.750	1.000	2.875	3.125	6.6
THK1.5	200	3,300	0 to 1-3/8	5.375	6.625	1.000	1.250	3.125	3.500	13.2
THK4.5*	500	9,900	0 to 1-3/4	8.625	8.625	1.750	4.000	4.375	4.375	35.3
THK6.0*	700	13,200	0 to 2-3/8	8.375	10.500	1.375	1.875	4.875	4.375	50.7
THK9	1,000	19,800	0 to 2-3/8	8.750	11.375	1.625	2.250	4.500	5.500	77.2

* Products available upon request

CP SERIES Pile Pinching Clamps

The CP clamps are designed specifically for pitching sheet steel and have the advantage of an attached rope for easy release from the ground. The rope presents a quicker method than the laborious procedure of release using a standard shackle. Piles must be prepared with a pitching hole of correct dimensions. These clamps are not designed to extract a driven pile and must not be used to remove piles under any circumstances. For pile removal use the PP series clamps.



- Designed specifically for pitching sheet steel piling
- Ideal clamp for heavy construction
- Rope is fitted for easy release from the ground
- Available up to 5 ton capacity
- Repair centers available to service your products
- Replacement parts available for clamps

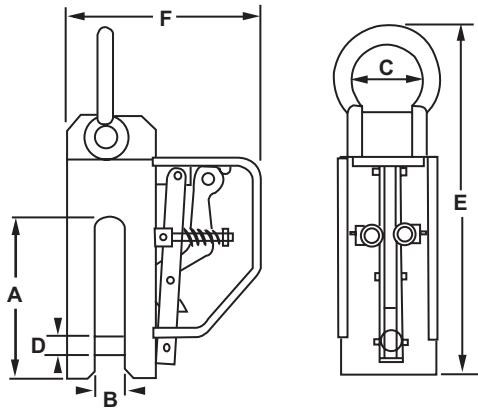

SPECIFICATIONS

Model	Working Load Limit	Dimensions						Weight
		A	B	C	D	E	F	
	lb.	in.	in.	in.	in.	in.	in.	lb.
CP2	4,400	8.976	0.787	2.000	0.787	16.750	8.500	41.9
CP3	6,600	8.976	1.024	2.500	1.181	17.875	8.875	50.7
CP5	11,000	8.976	1.378	3.250	1.181	19.875	9.500	72.8

HGC SERIES Hand Grip Clamps

The Camlok hand grip clamp is designed to carry or pull any object that will fit into the jaws. It can be used on all structural steel plates and sections up to a surface hardness of 300 Brinell. This clamp is not suitable for steel over 300 Brinell (32HRC), stainless steel, lead, copper and materials over 120°C/ 250°F surface temperature. The hand clamp is used to manually lift and carry material in a workshop environment. The innovative design enables the operator to open and attach the clamp to sheet material by depressing the lifting handle. Two pre-tensioned hardened serrated toothed jaws grip the sheet securely when the handle is released. Two pre-tensioned hardened serrated toothed jaws grip the sheet securely when the handle is released.



- Designed for manual lifts
- Maximum working load limit 500 lbs.
- Pre-tensioned serrated teeth for secure grip
- Suitable for material thickness up to 3/8"
- Excellent clamp for workshop use
- Prevents plate slippage
- Maximum hardness of material to lift should not exceed 300 Brinell (32HRC)
- Repair centers available to service your products
- Replacement parts available for clamps

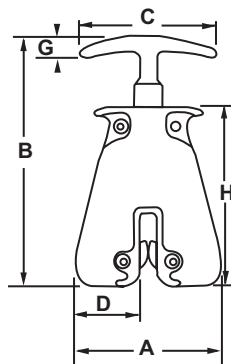

F = Thickness

DON'Ts

- **DO NOT** lift plates with a temperature of 120°C/ or 250°F
- **DO NOT** use to lift stainless steel, lead, and copper

SPECIFICATIONS

Model	Working Load Limit	Plate	Dimensions								Weight	
			A	B	C	D	E	F	G	H		
	lb.	in.	in.	in.	in.	in.	in.	in.	in.	in.	in.	lb.
HGC	500	0 to 3/8	4.25	7.25	3.875	1.875	2.125	0.875	0.375	5.125	2.0	

THS SERIES Horizontal Plate Clamps

The *Camlok THS series* of horizontal plate clamps can be used single or with two leg slings with a maximum angle of 60°. The clamps are designed to be used on structural steel plates up to a surface hardness of 300 Brinell (32HRc) providing the plate can withstand the forces imposed. The clamps have a spring/lever operated mechanism which securely locks the clamp onto the horizontally positioned plate. The ability to lock the clamp onto the plate enables a single operator to quickly set up the plate for lifting. The design allows you to lift and handle single sheet steel plates in a horizontal position. They are particularly useful for loading plates into guillotines, presses, punching machines and folding press. Caution should be used so that maximum single angle is not exceeded.



- Available in capacities up to 3 tons
- Handles plates up to 1-1/2" thick
- Spring lever for locking into place
- Can be used in single or 2 leg slings
- Maximum hardness of material to lift should not exceed 300 Brinell (32HRc)
- Use lifting beams for longer plates
- Repair centers available to service your products
- Replacement parts available for clamps

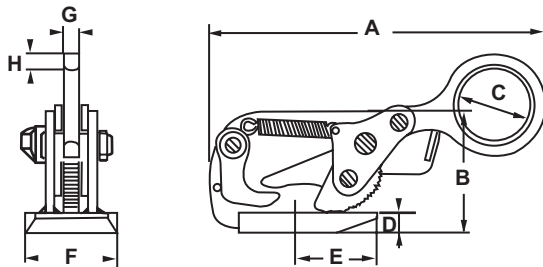

DON'Ts

- **DO NOT** use with endless or 3 or 4 leg slings
- **DO NOT** exceed 60° angle when lifting
- **DO NOT** lift plates with a temperature of 120°C/ or 250°F
- **DO NOT** use to lift stainless steel, lead, and copper

SPECIFICATIONS

Model	Working Load Limit		Jaw Capacity	Dimensions								Weight
	Min	Max		A	B	C	D	E	F	G	H	
	lb.		in.	in.	in.	in.	in.	in.	in.	in.	in.	lb.
THS0.75	90	1,600	0 to 3/4	10.039	3.819	1.969	0.591	2.756	3.150	0.472	0.591	6.6
THS1.5	175	3,300	0 to 1-3/8	13.189	4.724	2.756	0.787	3.150	3.543	0.591	0.669	13.2
THS3	500	9,900	0 to 1-3/4	17.717	7.717	3.543	2.323	4.331	4.331	0.787	1.181	37.5

TSH SERIES Screw Clamps

The **TSH clamps** are designed for pulling and holding sheet metal, girders, and related steel objects. The clamps are supplied complete with an alloy shackle that allows for pulling 180°. Screw cam pulling clamps are primarily used as anchor points to allow fabrications to be pulled together and positioned during assembly or prior to welding. These clamps have a screw cam pad. When load is applied to the clamp, the circular toothed pad pivots in a cam action, gripping the load. The clamps are attached by turning the screwed threaded axle.



- Available in capacities up to 5 tons
- Jaw capacity up to 3" thick
- Outstanding means of holding and securing loads
- High force screw threads
- Hardened steel jaws
- Swivel jaws increase grip if plate moves
- Maximum hardness of material to lift should not exceed 300 Brinell (32HRc)
- NOT recommended for lifting applications

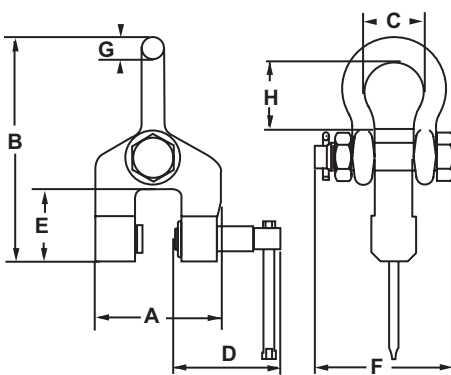

COMMON LEVER TOOL PROBLEM

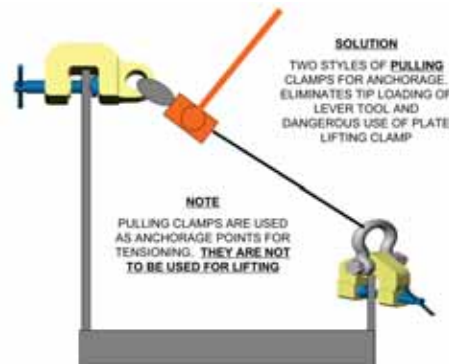

DON'Ts

- DO NOT lift plates with a temperature of 120°C/ or 250°F
- DO NOT use with stainless steel, lead, and copper
- DO NOT over torque the threaded axle, this could cause damage to the pad

SPECIFICATIONS

Model	Working Load Limit	Jaw Capacity	Dimensions								Weight	
			A	B	C	D	E	F	G	H		
	lb.	in.	in.	in.	in.	in.	in.	in.	in.	in.	in.	lb.
TSH1.5	3,300	0 to 1-1/4	5.118	10.039	2.559	4.528	2.953	5.000	1.024	3.701	15.4	
TSH3	6,600	0 to 2	6.693	11.417	2.913	4.921	3.346	5.669	1.181	4.646	24.3	
TSH5	11,000	0 to 3-1/8	10.039	18.504	5.118	6.890	5.315	9.449	1.969	6.890	59.5	

HG SERIES Vertical Plate Clamps

The **Camlok High Grip clamps** are designed to give additional grip forces to products during lifting. The High Grip has an additional lever in the clamping mechanism thus asserting a higher gripping force on the plate being lifted. The clamp has been designed to lift plates with harder surfaces as well as for use with stainless steel plates. The HG series is suitable for hardness up to 371 Brinell (40 HRC). Clamps can be used for lifting and turning plates from the horizontal to vertical position or vice versa. The standard clamp is fitted with a hook ring but can be alternatively supplied with a short length of chain. Clamps will mark the surface of the material being lifted.



- Can be used on hot rolled structural steel plates and sections up to a surface hardness of 376 Brinell. If over 376 Brinell (40 HRC) use LJ clamp.
- Can be used to lift Stainless Steel Plates or plates with harden surfaces due to cold rolling
- Lift plates from horizontal to vertical position and vice versa through 180°
- Clamp has serrated teeth and will mark plate
- Available in capacities up to 4 tons
- Jaw capacities up to 3/4"
- Smaller jaw range means more efficient for thinner steel
- Repair centers available to service your products
- Replacement parts available for clamps

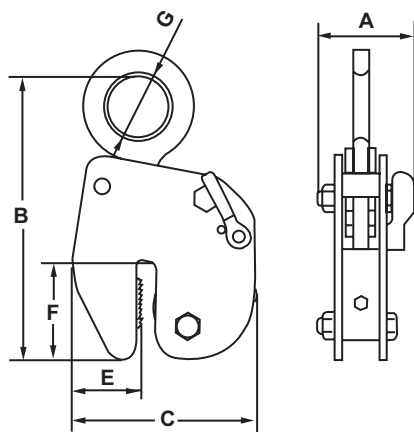

DON'Ts

- **DO NOT** side load clamp more than 15°
- **DO NOT** lift plates with a temperature of 120°C/ 250°F or Higher
- **DO NOT** use clamps on a double chain sling, when using two clamps to lift a steel plate, a lifting beam must be used between the two clamps to allow clamps to hang vertical

SPECIFICATIONS

Model	Working Load Limit		Jaw Capacity	Dimensions						Weight
	Min	Max		A	B	C	E	F	G	
	lb.	lb.		in.	in.	in.	in.	in.	in.	
HG0.5	100	1,100	0 to 3/8	1.654	9.055	5.827	2.165	3.110	1.969	11.0
HG1	150	2,000	0 to 5/8	3.661	11.698	8.268	2.638	4.488	2.638	26.5
HG2	450	4,400	0 to 3/4	4.331	16.378	12.008	4.016	6.260	3.150	48.5
HG3*	700	6,600	0 to 3/4	4.331	16.378	12.008	4.016	6.260	3.150	59.5
HG4*	900	8,800	0 to 3/4	4.724	13.189	12.008	4.016	6.220	3.150	70.5

* Products available upon request

CG SERIES Girder Turning Clamps

The **CG clamps** are general purpose clamps and can be used on rolled steel joists, beams, and fabrications up to a surface hardness of 300 Brinell (32HRc). This clamp can lift and turn girders through 90° and is designed to meet the requirements of the heavy steel industry. The clamp is designed to land the beam in either vertical or horizontal position. It incorporates a positive lock onto one of the uppermost edges, which will allow the beam to be set down with the flange vertical. For long girders, fabrications, and welded structures, two clamps and a lifting beam may be required.

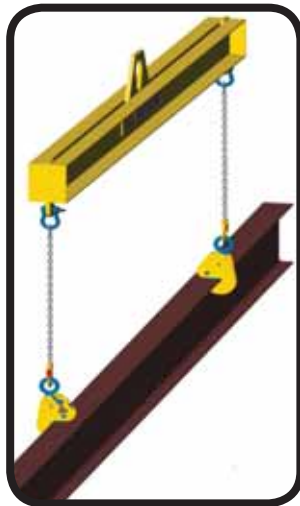

- Available in capacities up to 4 tons
- Jaw capacities up to 2"
- Can be used on beams, fabrications, channels, rolled steel joists
- This clamp can lift and turn beams up to 90°
- Can land beam in vertical or horizontal position
- Clamp is fitted with a cam/spring operated safety lock
- Use 2 clamps when lifting long lengths of beam
- These clamps can turn girders up to 90°
- Repair centers available to service your products
- Replacement parts available for clamps

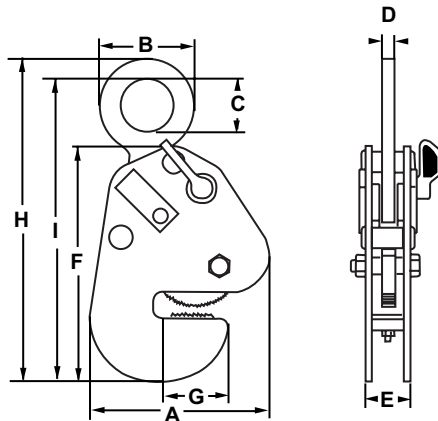

DON'Ts

- DO NOT lift plates with a temperature of 120°C/ 250°F or Higher

SPECIFICATIONS

Model	Working Load Limit		Jaw Capacity	Dimensions									Weight
	Min	Max		A	B	C	D	E	F	G	H	I	
	lb.	lb.	in.	in.	in.	in.	in.	in.	in.	in.	in.	in.	lb.
CG1	250	2,200	0 to 5/8	8.307	3.543	1.969	0.512	1.693	10.354	2.520	13.780	13.268	13.2
CG2	450	4,400	0 to 1-1/4	11.417	5.512	3.150	0.787	2.362	12.480	3.937	18.307	17.126	30.9
CG4	900	8,800	0 to 1-1/4	11.417	6.339	3.504	0.787	3.031	12.835	4.252	20.591	18.976	41.9
CG6	1,350	13,200	7/16 to 2	13.268	6.732	3.504	0.984	4.055	14.764	5.709	21.693	20.630	81.6

TTG SERIES Horizontal Girder Clamps

The **TTG clamps** are designed to lift and transport structural steel beams in the vertical position. The flanges are transported in the horizontal position. The clamps are fitted with a Camlok spring operated safety lock and is operated by pulling the locking handle upwards. Long beams should be lifted with two clamps attached on opposite beam flanges.



- Available in capacities up to 7.5 tons
- Available to fit flanges up to 1-3/4"
- Used to transport girders with flanges in the horizontal position
- Maximum hardness of material to lift should not exceed 300 Brinell (32HRc)
- For short beams, a single clamp can be used
- Longer beams should be lifted using 2 clamps and a lift beam with clamps located on opposite sides
- Repair centers available to service your products
- Replacement parts available for clamps

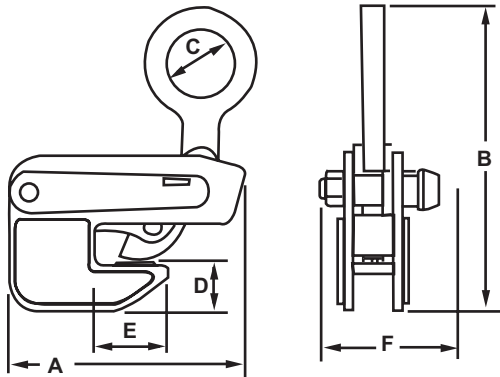

DON'Ts

- DO NOT lift plates with a temperature of 120°C/ 250°F or Higher

SPECIFICATIONS

Model	Working Load Limit		Plate	Dimensions						Weight
	Min	Max		A	B	C	D	E	F	
	lb.	lb.	in.	in.	in.	in.	in.	in.	in.	lb.
TTG1.5	200	3,300	0 to 1-1/8	9.000	10.875	3.750	1.750	2.750	4.000	12.1
TTG3	350	6,600	0 to 1-3/8	11.125	11.625	3.125	2.125	2.875	4.500	24.3
TTG4.5*	1,000	9,900	0 to 1-1/2	12.375	13.250	3.500	2.375	3.000	4.625	32.0
TTG7.5*	1,650	16,500	0 to 1-3/4	14.500	15.000	4.375	2.500	3.625	6.625	61.7

The **BTG clamps** are designed to lift and handle concrete manhole pipes in the vertical position. These clamps enable the manhole trench size to be minimized and facilitate accurate positioning of pipes on top of each other. These clamps are sold in sets of three. Attachment and removal of the clamps from the pipes is extremely easy due to the simple and straight forward design.



- Available in capacities up to 3-3/4 tons
- Available jaw width up to 8-1/2"
- Solid construction design
- Sold in sets of 3 (Chain Sling not included)
- Simple handling
- Large jaw capacity
- Light weight design
- Service friendly
- Made in China

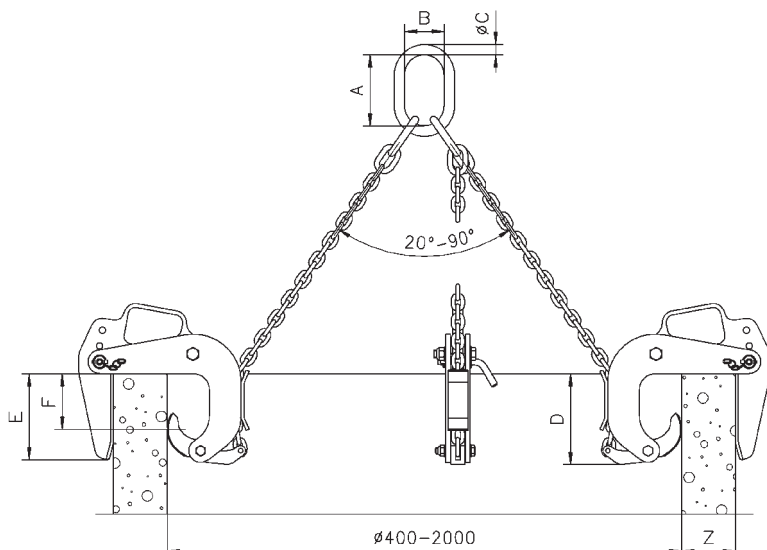

Note: Chain Sling not included

SPECIFICATIONS

Model	Working Load Limit (Per set of 3)	Jaw Capacity (Z)	Dimensions						Weight	
			A	B	C	D	E (Mouth)	F (Pressure Line)		
	lb.	in.	in.	in.	in.	in.	in.	in.	in.	lb.
BTG1500/3	3,300	1-1/2 to 4-3/4	5.315	5.315	0.709	7.087	6.496	3.937		75.0
BTG3000/3	6,600	2 to 7	6.890	3.937	1.024	12.205	9.646	6.890		132.3
BTG3000L/3	6,600	3-1/2 to 8-5/8	6.890	3.937	1.024	12.205	9.646	6.890		172.0

SCREWLOK BEAM CLAMP WITH SHACKLE

Camlok Beam clamps are designed for attachment to the lower flanges of structural steel beams to provide a semi permanent lifting point. The clamps can be quickly and easily attached via the screw type mechanism. This series of clamps is fitted with a suspension shackle allowing for quick and easy component attachment.



- Available in capacities up to 10 tons
- Available jaw width up to 12"
- Shackle furnished for quick and easy component attachment
- Available in single or double clamps

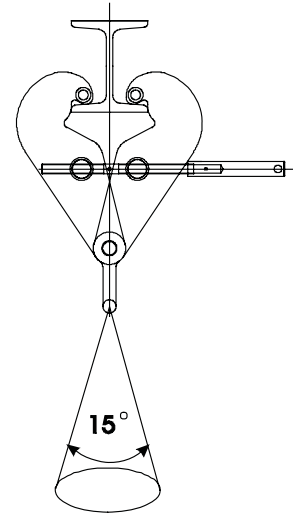

SPECIFICATIONS

Model	Working Load Limit	Flange	Dimensions						Weight
			A	B	C	D	E	F	
	lb.	in.	in.	in.	in.	in.	in.	in.	lb.
SC921	2,200	3 to 8-1/4	12.625	12.125	1.750	8.250	5.375	2.625	11.0
SC922	4,400	3 to 8-1/4	12.625	12.875	1.750	8.250	5.375	2.875	13.5
SC923	6,600	4 to 10-5/8	16.125	14.750	1.750	10.625	6.500	4.000	17.5
SC923/	6,600	3 to 12	17.375	16.500	1.750	12.000	8.625	4.000	20.0
SC925	11,000	4 to 10-5/8	16.125	15.375	2.125	10.625	8.500	4.375	22.0
SC925/	11,000	3 to 12	17.125	17.125	2.125	12.000	8.625	4.375	26.5
SC9210	22,000	3 to 12	18.125	20.000	3.250	12.000	8.625	4.375	35.5

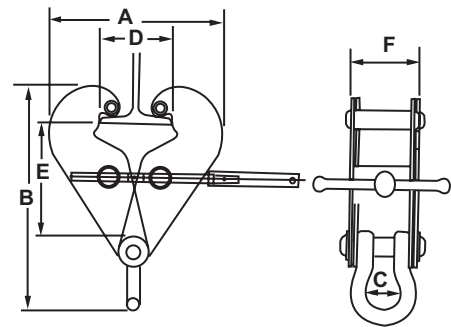

SC SERIES TWIN BEAM CLAMP

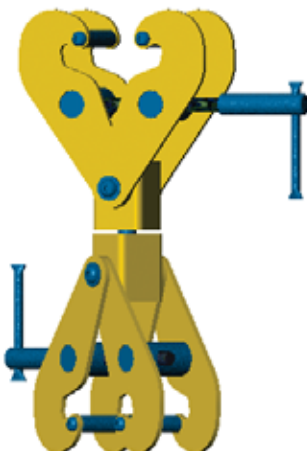

Model	Working Load Limit	Flange Width		Weight
		Minimum	Maximum	
	lb.	in.	in.	lb.
SC922T	4,400	2.995	8.387	28.7
SC923T	6,600	3.994	10.783	35.3
SC923/LT	6,600	2.995	12.181	44.1
SC925/T	11,000	3.994	10.783	50.7
SC925/LT*	11,000	2.995	12.181	59.5

CTP SERIES Beam Clamp

CTP Screwlok clamps are based on the SC beam clamp series, where we have incorporated a four wheel trolley. The easy installation to any beam makes the CTP suitable for affixing and moving hoists, pulleys, and loads. The trolley is adjustable to suit various beam flange widths by turning the handle of the screw mechanism. Tightening the locking lever nut against the trolley side plate aligns the trolley wheels at the correct span. The trolley wheels have pre-lubricated ball bearings. The model CTP1 is of lightweight construction and fitted with polyurethane plastic wheels.



- Available in capacities up to 3 tons
- Available to fit flanges up to 8-1/4"
- Adjustable to fit various flange widths
- Pre lubricated ball bearings on each unit
- Easily attaches hoist, pulleys or slings
- Repair centers available to service your products
- Replacement parts available for clamps
- Made in China

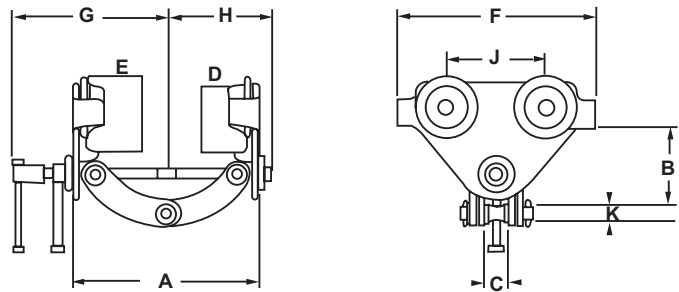

SPECIFICATIONS

Model	Working Load Limit	Jaw Capacity	Min Curve Radius	Dimensions												Weight
				A		B		C	D	E	F	G	H	J	K	
				Min	Max	Min	Max									
	lb.	in.	in.	in.	in.	in.	in.	in.	in.	in.	in.	in.	in.	in.	in.	lb.
CTP1	2,200	2-3/8 to 5-7/8	0.035	3.740	7.283	3.228	4.291	1.024	2.598	2.874	6.299	6.024	4.134	2.953	0.866	4.9
CTP2	4,400	3 to 7-7/8	0.045	4.921	9.843	4.173	6.102	1.654	3.543	3.937	10.236	8.071	5.472	5.118	0.787	21.8
CTP3	8,800	3 to 7-7/8	0.055	5.315	10.236	5.039	6.732	1.969	4.331	4.921	12.205	8.661	6.102	5.906	0.866	38.6

CLB SERIES Lifting Lugs

The **CLB container lugs** are supplied in sets of four. They are available with a total capacity of 56 tons. The CLB series serve as flexible lashing points for the transportation of containers. The CLB lugs are mounted horizontally to the side of the container at either the top or bottom fixing holes. This model has a spring loaded bolt to prevent accidental release.



- Spring loaded bolt to prevent accidental release
- Mounted at the side of the container in either upper or lower holes
- Easy installation and removal, simple insert and turn installation
- Designed to eliminate the dangerous use of standard hooks
- Lugs cannot drop out when slings become slack
- Lugs can be used left hand or right hand turns
- For maximum capacity use a lifting beam in conjunction with the CLB lifting lugs

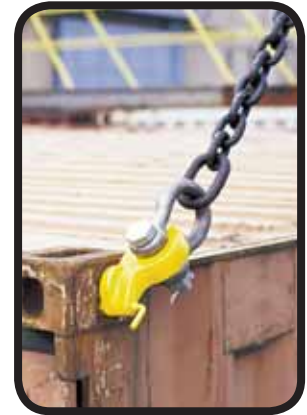

SPECIFICATIONS

Model	Working Load Limit (Per set of 4)	Dimensions							Weight
		A	B	C	D	E	F	G	
Imperial									
	lb.	in.	in.	in.	in.	in.	in.	in.	lb.
CLB32	70,500	5.984	7.126	1.772	1.457	2.874	2.953	1.575	39.7
CLB40	88,100	5.984	7.126	1.772	1.457	2.874	2.953	1.575	39.7

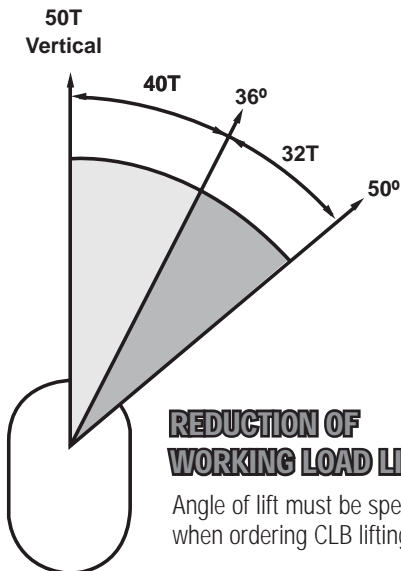
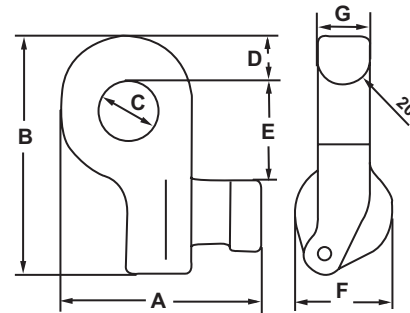

CLB DESIGN

Designed to eliminate the use of standard hooks as attachments.

CLB SAFETY INFORMATION

NOTE: Minimum angle will depend on W.L.L. Required

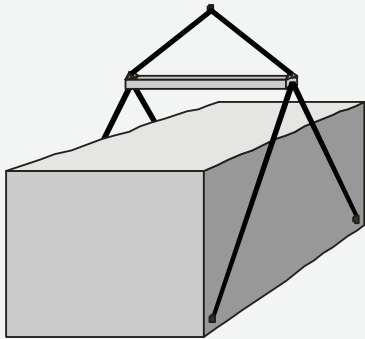

1. Spreader beam adds stability to lift.

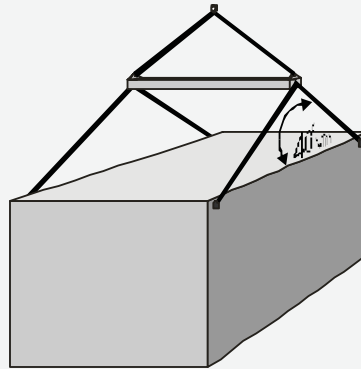

2. CLB lugs can be used in the top fitting also.

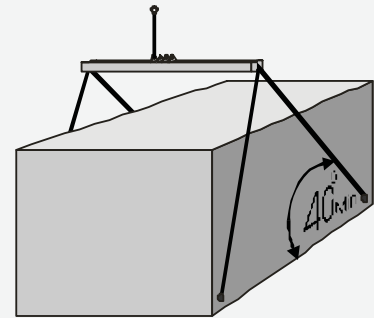

3. Un-symmetrically loaded containers can be handled by using lifting beams and shortening chain slings.

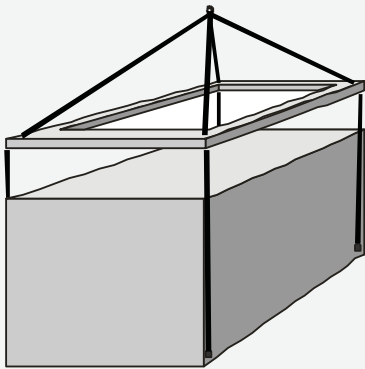

1. Bottom side

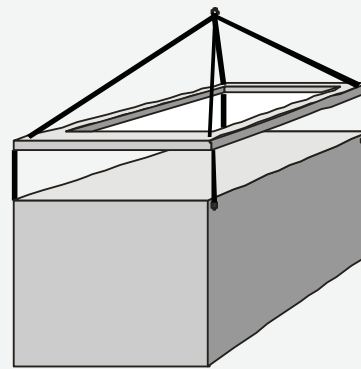

2. Top side

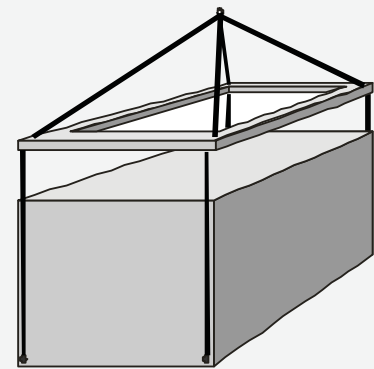

3. Bottom end

For maximum load capacity a lifting frame can be used with the lugs attached as above.

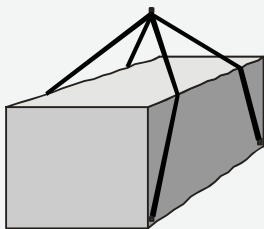

Lifting frames offer little stability.

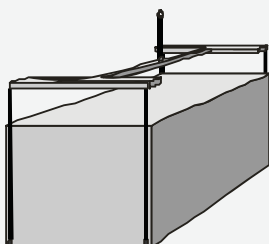

NOT recommended, sling may damage container.

DO NOT USE

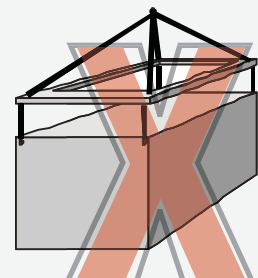
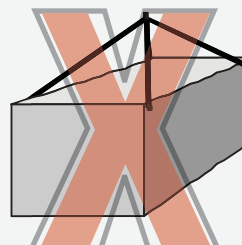
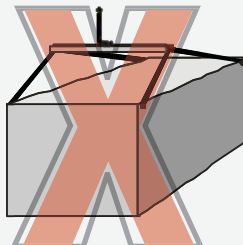

FOR FURTHER INFORMATION CONTACT
CUSTOMER SERVICE AT 800-888-0985

CAMLOK SPARE PARTS

'92 SERIES - VERTICAL PLATE LIFTING CLAMPS

No special tools are required to repair clamps. Heat may be required to release the bonding compound on some screws.

After repair use STUDLOCK on all screws removed.

Always quote clamp serial number, part description and model when ordering spares.

Reference	Description
10	Shell plates (set of 4)
16	Shell pins (set of 3)
17	Shell screws (6 off)
20	Internal assembly
27	Spring
31	Hook ring
32	Hook ring pin
40	Cam assembly
41	Cam
47	Locking lever and pin
50	Pad assembly

ONLY USE GENUINE CAMLOK SPARE PARTS

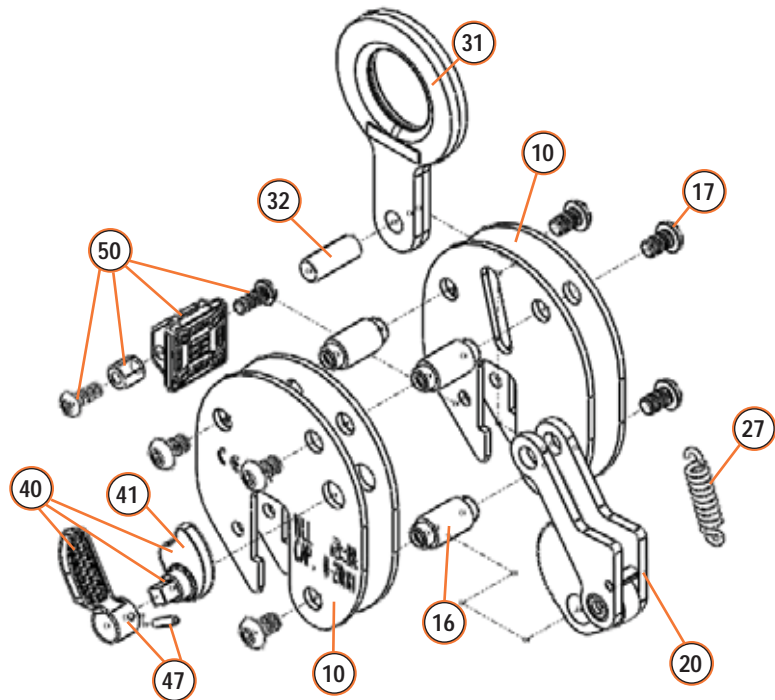

CZ - VERTICAL PLATE LIFTING CLAMPS

No special tools are required to repair clamps. Heat may be required to release the bonding compound on some screws.

After repair use STUDLOCK on all screws removed.

Always quote clamp serial number, part description and model when ordering spares.

Reference	Description
10	Shell welded assembly
20	Internal assembly
27	Spring
31	Hook ring
32	Hook ring pin
40	Cam assembly and lever
41	Cam
47	Locking lever and pin
50	Pad assembly
60	Jaw bolt assembly

ONLY USE GENUINE CAMLOK SPARE PARTS

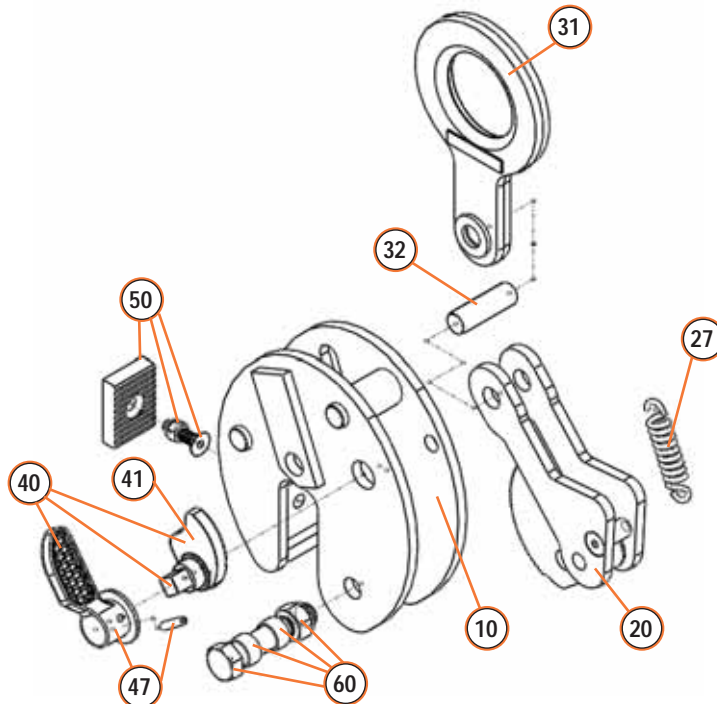

CY - "HINGED" VERTICAL PLATE CLAMPS

No special tools are required to repair clamps. Heat may be required to release the bonding compound on some screws.

After repair use STUDLOCK on all screws removed.

Always quote clamp serial number, part description and model when ordering spares.

Reference	Description
10	Shell plates (set of 4)
16	Shell pins (2 each)
17	Shell screws (set of 4)
20	Internal assembly
27	Spring
32	Hook ring pin
34	Hook ring fork
35	Swivel hook ring
37	Eye bolt and nut
40	Cam assembly
41	Cam
47	Locking lever and pin
50	Pad Assembly
60	Jaw bolt assembly

ONLY USE GENUINE CAMLOK SPARE PARTS

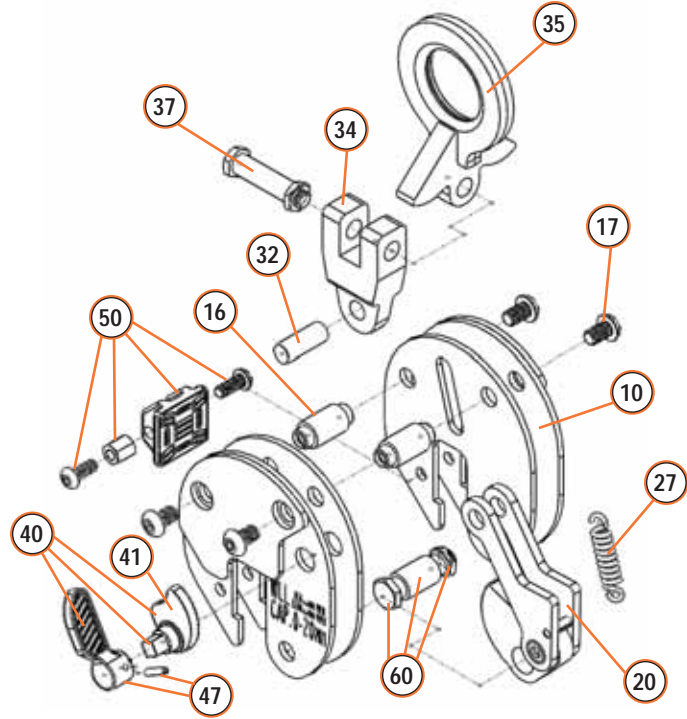

CX - "HINGED" VERTICAL PLATE CLAMPS

No special tools are required to repair clamps. Heat may be required to release the bonding compound on some screws.

After repair use STUDLOCK on all screws removed.

Always quote clamp serial number, part description and model when ordering spares.

Reference	Description
10	Shell welded assembly
20	Internal assembly
27	Spring
32	Hook ring pin
34	Hook ring fork
35	Eye cam
37	Eye bolt and nut
40	Cam assembly
41	Cam
47	Locking lever and pin
50	Pad assembly
60	Jaw bolt assembly

ONLY USE GENUINE CAMLOK SPARE PARTS

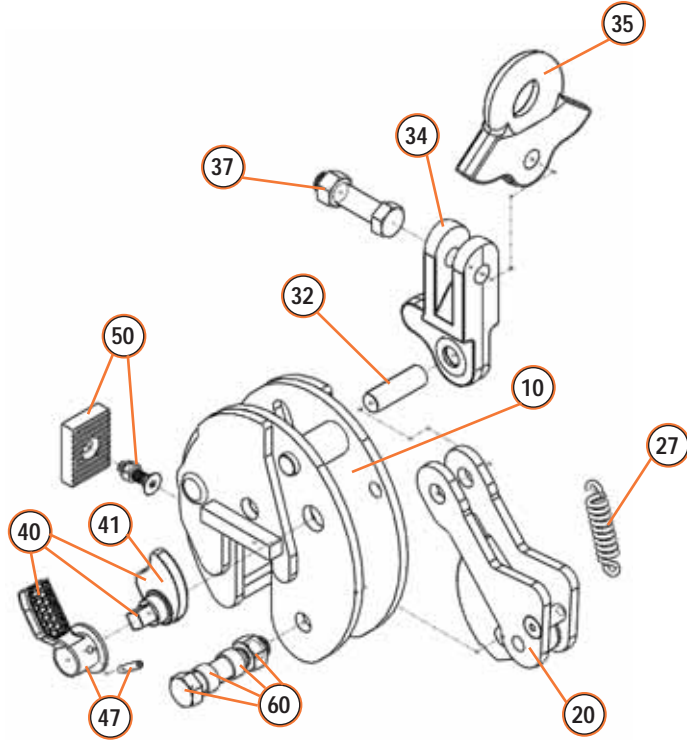



www.cmworks.com

CAMLOK

A COLUMBUS McKINNON BRAND

Amherst, NY

Phone: 800-888-0985 or 716-689-5400

Fax: 716-689-5644

CMR-CAMLOK-1009

SS 2.5M 10/09 MU

© 2009 Columbus McKinnon Corporation