

FESTO

Automation Technology
Pneumatic and electrical components



Festo's entire product range on DVD-ROM



FESTO

Products

Minimum system requirements

- Pentium IV, 2.4 GHz+ or AMD 2400 xp+
- 1 GB RAM
- DVD-ROM drive
- Screen resolution set to 1024 x 768 pixels
- Windows XP SP2
- Internet Explorer 7

Recommended system requirements

- PC, no more than 4 years old
- Laptop, no more than 2 years old
- Dual-core CPU with 2 GHz
- 1.5 GB RAM
- DVD-ROM drive
- Screen resolution set to 1280 x 1024 pixels
- Windows XP (SP2 or SP3), Vista or Windows 7 (32 or 64 bit) or Windows 8

Installation instructions

1. Insert the DVD-ROM into the drive. If the setup routine starts automatically, continue with Step 5.
2. If not: Select the **Run** command from the Start menu.
3. Enter the drive letter of your DVD-ROM drive followed by **setup.exe**.
4. For example: **d:\setup.exe**
5. Then click on **OK** or **Enter**.
6. Follow the instructions.

For further information (installation in a network, FAQs), please read **Info_en.pdf**

Exclusion of liability

Festo provides this software to support you in the selection and ordering of Festo products. The data/results generated using the software are exclusively intended to describe the products and do not constitute warranted properties in any legal sense. Festo accepts no liability for

damages caused through the use of this software, in particular in relation to consequential damage, whether

personal injury, material damage or financial loss, directly related to the use of this DVD-ROM.

Marketing Instruments & Product
Data Service
E-mail: DKI@festo.com
Internet: www.festo.com

FESTO

Automation Technology
Pneumatic and electrical components

Automation Technology –
Pneumatic and electrical components

Edition 2013/11

All technical data are correct at the
time of going to print.

All texts, representations, illustrations
and drawings included in this cata-
logue are the intellectual property of
Festo AG & Co. KG and are protected
by copyright law. All rights reserved,
including translation rights. No part of
this publication may be reproduced or
transmitted in any form or by any
means, electronic, mechanical, photo-
copying or otherwise, without the
prior written permission of
Festo AG & Co. KG.



















All technical data are subject to
change according to technical
updates.

Festo AG & Co. KG
Postfach
73726 Esslingen
Ruiter Straße 82
73734 Esslingen
Germany



More information

- Editorial → 2
- Easy selection – quick ordering → 6
- Online or offline → 7
- Festo online shop → 10
- Partnership for a better automation solution → 11
- Festo Didactic → 12

- Technical information → 1032
- Type and product index → 1057

1	Pneumatic drives		→ 13	1
2	Servopneumatic positioning systems		→ 285	2
3	Electromechanical drives		→ 291	3
4	Motors and controllers		→ 409	4
5	Grippers		→ 477	5
6	Handling systems		→ 503	6
7	Vacuum technology		→ 507	7
8	Valves		→ 513	8
9	Valve terminals		→ 617	9
10	Sensors		→ 719	10
11	Image processing systems		→ 789	11
12	Compressed air preparation		→ 791	12
13	Pneumatic connection technology		→ 893	13
14	Electrical connection technology		→ 939	14
15	Control technology and software		→ 957	15
16	Other pneumatic devices		→ 989	16
17	Ready-to-install solutions		→ 997	17
18	Services		→ 1019	18

Colour key

- Chapter tabs:
 -  Pneumatic components
 -  Electrical components
- Grey text on the catalogue pages: you will find these products online; see description → 7
- Blue text on the catalogue pages: Type code for Internet search(es)
- ★ Product from our standard product range for easy selection and quick ordering

A black and white photograph of a middle-aged man with short, light-colored hair, wearing a dark suit jacket, a white shirt, and a striped tie. He is sitting at a desk, looking directly at the camera with a slight smile. In the foreground, a Festo pneumatic cylinder is visible on the desk. To the right, a keyboard is partially visible. The background is a blurred office setting.

We are pneumatic.
We are electric.
We are 30,000 technology-neutral solutions.

**→ WE ARE THE ENGINEERS
OF PRODUCTIVITY.**

Dear customer,

Companies seeking to be globally successful need to systematically increase their competitiveness. We can support you in achieving this by focusing on our shared goal of: **improving your productivity.**

In this catalogue you will find answers to how you can boost your productivity. With products like

- the electric cylinder EPCO,
- the valve solutions VTUG with
- the simple fieldbus connection CTEU or
- the first self-adjusting pneumatic cylinder cushioning PPS.

All **technical milestones in automation** which will make your work much easier.

Thank you for your confidence in the Festo brand and its products. That is what motivates and drives us to make you even more successful. We take advantage of everything possible to make this happen – our knowledge, our capabilities, our performance, our products, services and training offerings. Our approach to solving your automation tasks is based on four outstanding qualities:

Security, Efficiency, Simplicity and Competency.

This makes us what we are:

- ➔ Experts who don't give up.
- ➔ Professionals who make the working day easier for you.
- ➔ Technicians who can always get a little more out of components and systems.

Or simply engineers of productivity.

Benefit from this enthusiasm which goes into our automation solutions, services and training offerings for your factory and process automation tasks.

An enthusiasm which you will feel every time you work with us.

We're there for you – making you feel secure.

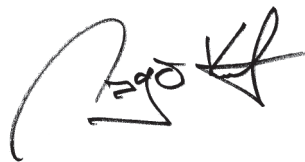

Dr. Ansgar Kriwet
Member of the Management Board Region and Sales Europe

**We drive automation for your success.
We are your partner to inspire you.
We shape the future together.**

→ WE ARE THE ENGINEERS OF PRODUCTIVITY.

Maximum productivity for you and your customers – this is our mission.

Our know-how, our holistic approach and our love of detail have made us a global leader in automation technology – and the world market leader in basic and further technical training.

With over 60 years' experience in factory and process automation, we are the right partner for you. Always able to provide an appropriate solution which is characterised by security, simplicity, efficiency and competency.

Security

We want you to feel secure during each and every phase of our collaboration. And confident that you are increasing your productivity. You can rely on our specialists as well as the quality of our products and processes – always and everywhere. This is what we stand for as a family-run company with a long tradition in factory and process automation.

Efficiency

Save energy, materials and effort and reduce both your CO₂ emissions and your operating costs. With advice and services from Festo for tailored, economical and intelligent solutions. This is how you permanently increase the productivity of your company.

Simplicity

We make your work easier. From the first idea and product selection through to after sales. We reduce complexity with new product generations and software tools for quick product selection and configuration – simplicity is our philosophy. This gives you more time for the really important things: your core business and customers.

Competency

Work with experts who understand your industry. We have been setting trends in automation for decades. We smooth the way to maximum productivity with experience and dedication. Our experience is the key to your success: from consultation through to development, training, seminars and products. That is competency in action.

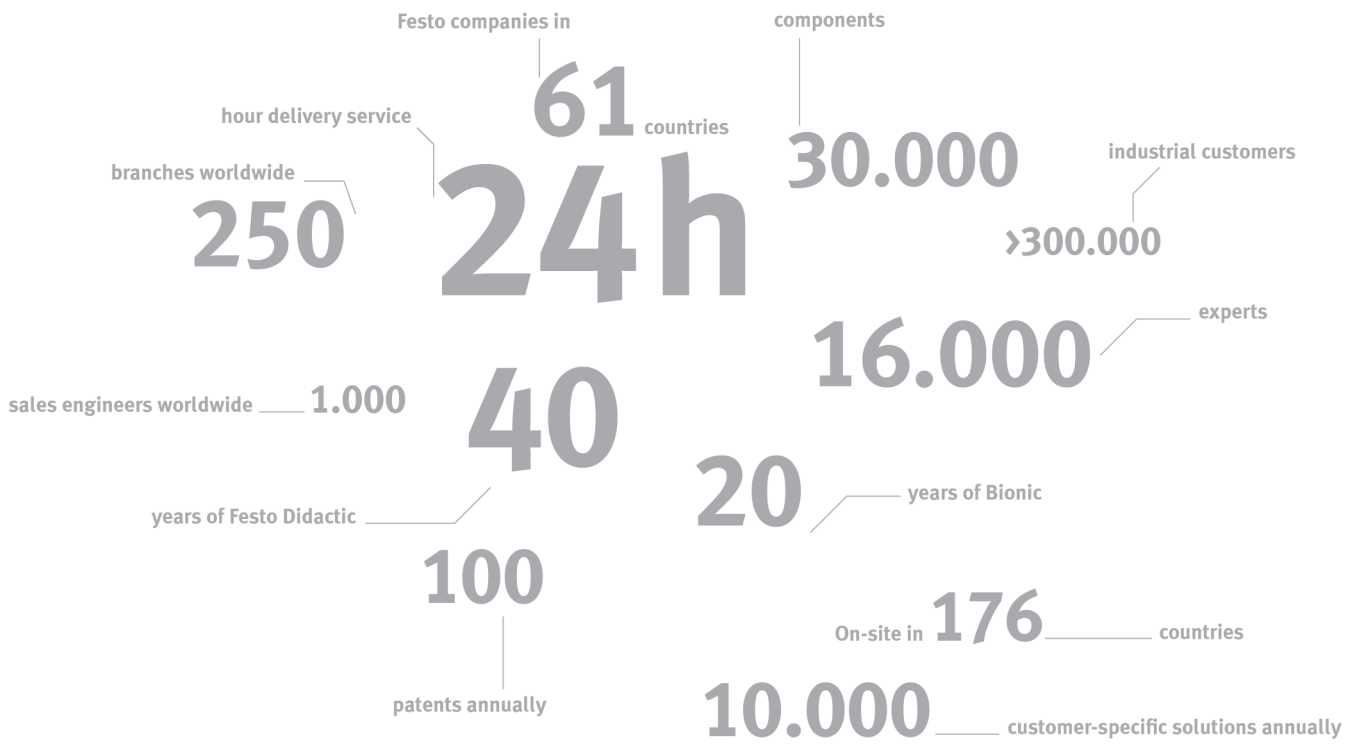

★ Quick ordering

We make it easy for you – Festo presents the new standard product range

Created for quick and easy selection, the new, global standard product range is based on the full product range. It has been selected by Festo experts based on actual customer requirements and covers the main applications of automation technology, while offering the best possible value for money.

Products with the star: easy selection guaranteed

The global standard product range can be recognised at a single glance: it's

identified in all the catalogues with a star.

Quick and easy ordering

Preconfigured to ensure the best possible value for money, all products from the standard product range can be ordered quickly and easily either via the self-explanatory order code or the unique part number.

High level of availability

In stock and ready for immediate shipment, the global standard product range is on-site in no time at all, unless otherwise specified.

Ordering using the order code

The order code for each product can be found on the product pages.

The appropriate accessories for each product are presented in tabular format at the end of each product description.

It couldn't be easier: to get the correct order code, complete the boxes in the first line starting from the left. Follow the connecting line from each box to the column with the associated sizes and variants and make your selection. There are three types of boxes:

- Mandatory data with predefined content **1**: in the example on the right, this is the first box containing the basic design DSNU
 - Mandatory data (blank box) **2**
 - Optional data (line only) **3**: if nothing is entered here, the basic design will be supplied (in this example this means a piston rod at one end)
- When making your selection, note the conditions associated with the variants **4** (shown as footnotes).

More variety or individually configurable? No problem!

If your requirements go beyond the main applications of automation technology or you need individually configurable products such as valve terminals, you can choose from the full spectrum of Festo's automation portfolio with all of its technological diversity.

It can be found in the overview in this printed catalogue, in our electronic catalogue or online on our website and in the online shop.

Our standard product range offers everything you need for the main applications of automation technology.



Whenever you see this symbol in the printed or electronic catalogue, it means the product is from our new standard product range for the main applications of automation technology. The symbol provides you with quick guidance, and makes it easier to place your order. Unless otherwise specified, all products included in this range are in stock and ready for immediate delivery.

Sample order code:

Order code: **DSNU** - **1** - **2** - **3** - **4**

Type	DSNU	Double acting standard cylinder
Pressure operating medium	Q	With protection against moisture
Piston rod (mm)	12	Stroke (mm)
12, 16, 20, 25		12, 16, 20, 25
Piston rod	A	Through piston rod
Piston rod thread type	F	Female thread
Conditioning	P	Pressure adjusting device at both ends
P	PH	Pressure adjusting device at both ends, self-adjusting
P	PH	Pressure adjusting device, adjustable
Position sensing	A	Yes, inductively
Standard	W	Conforms to ISO 15552
Temperature range	1	Non-resistant seals up to max. 120 °C
	-1	Non-resistant seals up to max. 150 °C
Wiper seal variant	A1	Styrene butadiene elastomer
Piston rod sealant	E	More
		Stroke up to 500 mm

1 Mandatory data with predefined content (DSNU)
2 Mandatory data (blank box) (Q)
3 Optional data (line only) (12, 16, 20, 25)
4 Conditions associated with the variants (A, F, P, PH, A1, E)

Online: Enter www.festo.com in your web browser, then choose your country in the "Automation" field. Click on "Go".
On the homepage, select the "Products" menu.

Offline: Insert the DVD and install the product catalogue.
On the start page, click on the "Products" link.

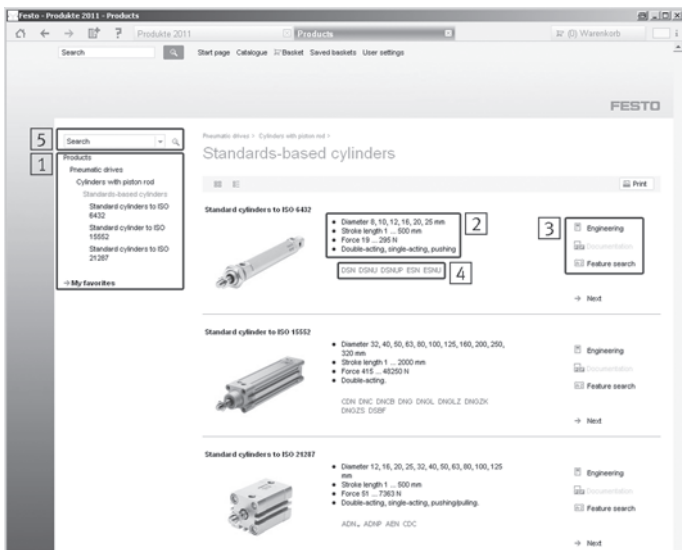

From the product group to the product

There are three options available:

1. Click on a product group [1] or product photo. A selection of products will then be displayed along with a list of the technical features [2] and selectable links [3]:
 - "Engineering" starts the selection and calculation software
 - "Documentation" provides detailed information in PDF format
 - "Feature search" lets you further narrow down the product selection
2. Full text search: Enter your search term in the search field [5]. This can be made up of complete or partial keywords, part numbers, type codes or names of favourites. Depending on your input, a selection of products as described in step 1 will be displayed or you will be taken directly to the product you searched for.
3. Quick link: Use the quick link [4] to take you directly to the required product by clicking on a type code.

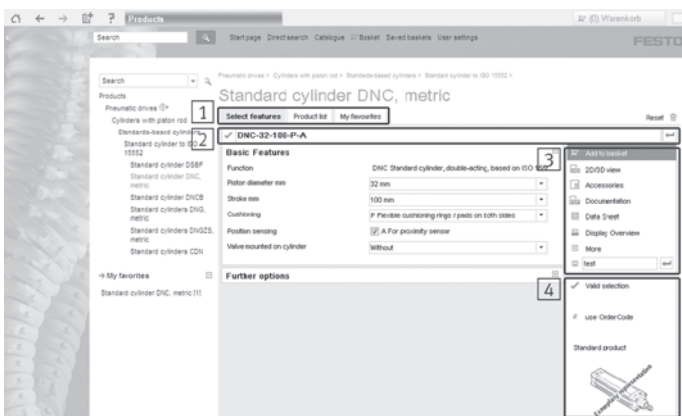

Functions in the product configurator

1. Tab navigation [1]
 - "Select features": Select the appropriate features here
 - "Product list": Lists all products in the product group
2. Input field for type code [2]: Enter the exact type code here.
3. Other actions [3] which are available following a correct configuration:
 - "Add to basket": Adds your product to the basket, see also the sections "Exporting your basket" and "Managing your basket"
 - "2D/3D view": Creates a CAD model, see the section "Viewing CAD models"
 - "Accessories": Lists suitable accessories
 - "Data Sheet": Contains all the relevant technical data
 - "Display Overview": Displays an overview of all selected models
4. Details [4]: Here you will find information such as part number, price, product graphic, product illustration and circuit symbol.

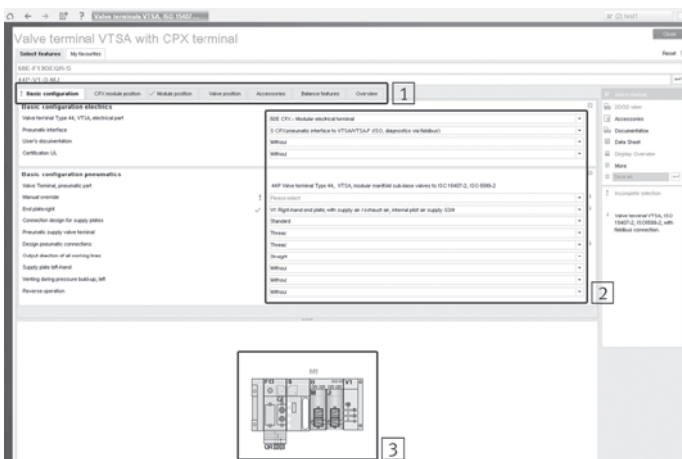

Selecting product features in the product configurator

1. Select the product features:
 - Navigate using the tabs [1].
 - Configure your product by selecting the required features [2] on the tabs [1] running from left to right.
 - The tabs [1] give you a quick overview of all the selected features. Missing features are marked with a blue exclamation mark and incorrect features are marked in red. Clicking on the feature takes you directly to it, so that you can then change it.
 2. Graphical representation [3]: A dynamic graphic¹⁾ is created based on your current configuration.
 3. Add the product to the basket: Once the configuration is complete, you can add products to the basket by clicking on "Add to basket". A message is displayed to confirm that the product has been added successfully.
To find out how to place an order, see the section "Managing your basket".
- 1) Available for the valve terminal and service unit product groups.

Online or offline – get the ideal solution fast

Online: Enter → www.festo.com in your web browser, then choose your country in the "Automation" field. Click on "Go".
On the homepage, select the "Products" menu.

Offline: Insert the DVD and install the product catalogue.
On the start page, click on the "Products" link.

Selecting product features in the product finder

1. Click on a round, blue icon [1] in the required product group.
2. Click on the required product finder in the "Product finder" field [2].
3. Select the required technical features in the selection field [3] on the left-hand side.
4. Then click on a product photo. The configurator [4] opens with the features you selected.

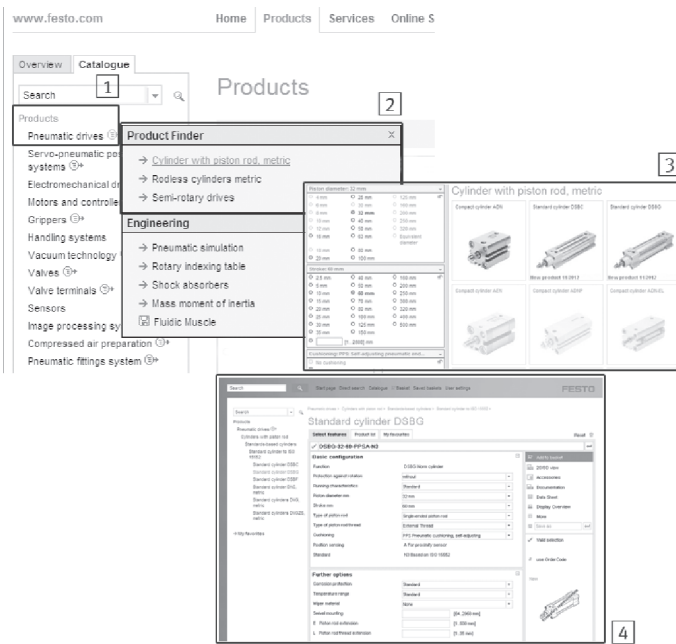

Engineering tools for appropriate products for your applications

1. Click on a round, blue icon [1] in the required product group.
2. Click on the required engineering tool in the "Engineering" field [2].

This tool guides you step-by-step to the application simulation based on the technical features you selected and suggests the appropriate products for your application.

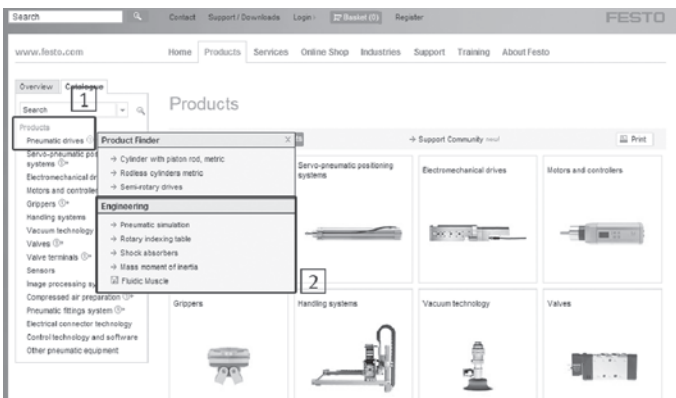

Finding the appropriate accessories quickly

1. Select the required features in the configurator.
2. Click on the "Accessories" button [1] on the right-hand side.
3. Select the required accessory from the accessories on offer [2].

Tip:
For some cylinder series you can find the appropriate accessories faster by selecting "Recommended accessories" in the accessories on offer [2].
For some cylinder series you will also find "Recommended accessories" [3] after you have added your selection to the basket.

The tool will bring you to the appropriate accessory selection list.

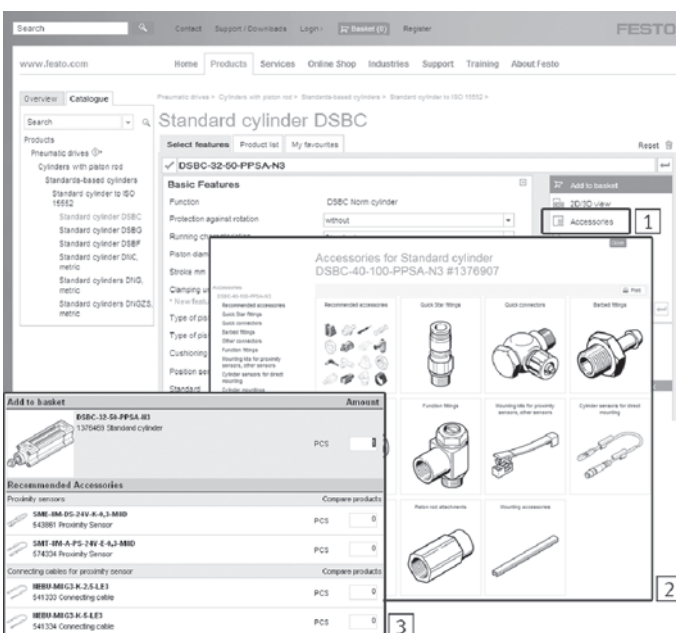

Online: Please register as a user to use the functions described on this page.

Offline: Registration is not required to use the functions on this page.

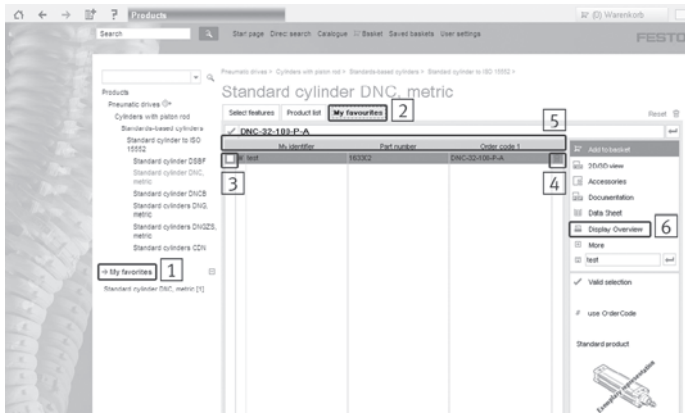

My favourites

You can save as many product configurations as favourites as you want.

To display the list of all stored favourites [1]:

- Click on the "My favourites" tab [2]. A table containing your saved favourites is displayed.

The name of the favourite, part number, type code and a button [4] for deleting the favourite are displayed.

- Double-clicking on a row in the configuration opens the corresponding configuration window [3].
- You can sort your favourites by clicking on the column headings [5].
- You can select multiple favourites and compare them by clicking on "Product compare" in the field on the right [6].

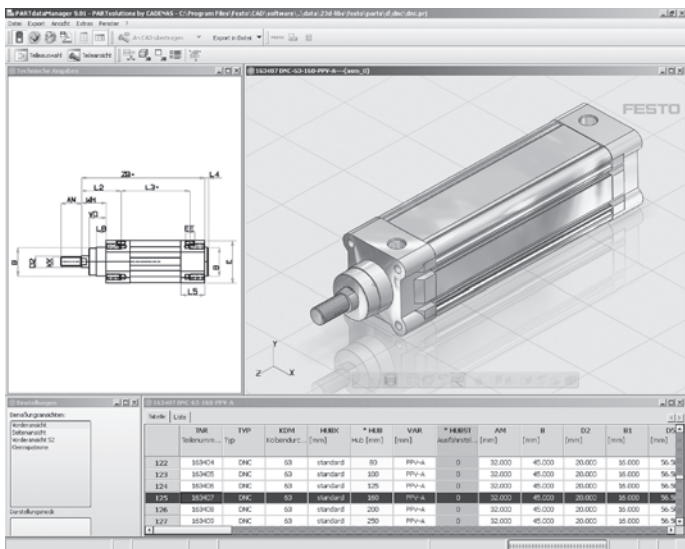

Viewing CAD models

Clicking on the "2D/3D view" button opens a window containing a CAD preview of the product. The "Export" function lets you export the files to your CAD system in the right format.

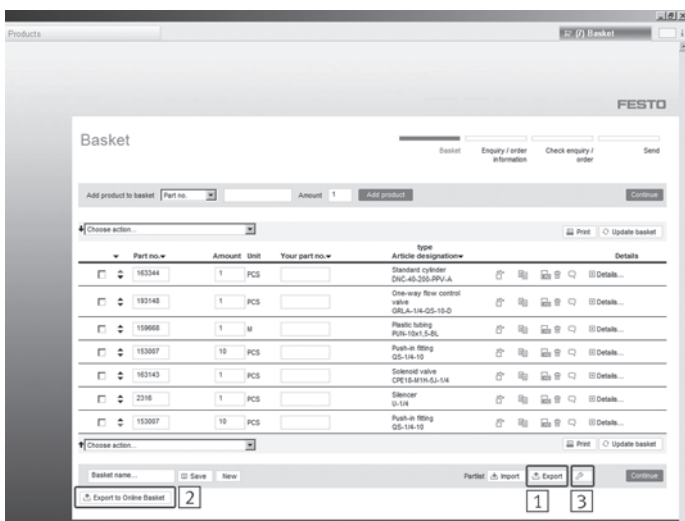

Exporting your basket...

1. ... as a csv file:
To do this, click on "Export" [1], choose "Save as" in the new window and specify where you want to save it to. This file can then be opened in Excel, for example, and edited.
2. ... to your required format: To do this, click "Settings" [3] and specify which information is to be exported.

To upload a basket directly to the online shop, simply click "Export to online basket" [2]. An Internet connection is established and the products are transferred to the online basket. After logging in via "Login", your net prices and delivery times are displayed. Now just place your order and you're done!

Managing your basket

1. Upload the basket directly to the online shop and place your order:

2. Place an order: To place an order, simply print out your basket and send it to Festo by fax or export it as an e-mail.

Online: **The Support Portal**
All product information can be accessed centrally → www.festo.com/sp

Round-the-clock benefits

- **One-step ordering process** – no waiting times between request, pricing information and order.
- **Complete overview of all orders** – order tracking with search function, status display in lists and easy reordering.
- **Access to all technical information** – all information and documentation for products and accessories in the catalogue.
- **Project work online, without waiting times** – instead of sending requests by fax, check prices and availability interactively online.
- **Continuous availability** – product information, documentation, prices, availability, ordering, etc.
- **Reliable and secure procurement processes** – import parts lists as a CSV file or by copying and pasting. Export to Office applications.

Always in control

When you register you have access to all the latest information on all the products and their availability at all times

You will find the online shop at

→ www.festo.com

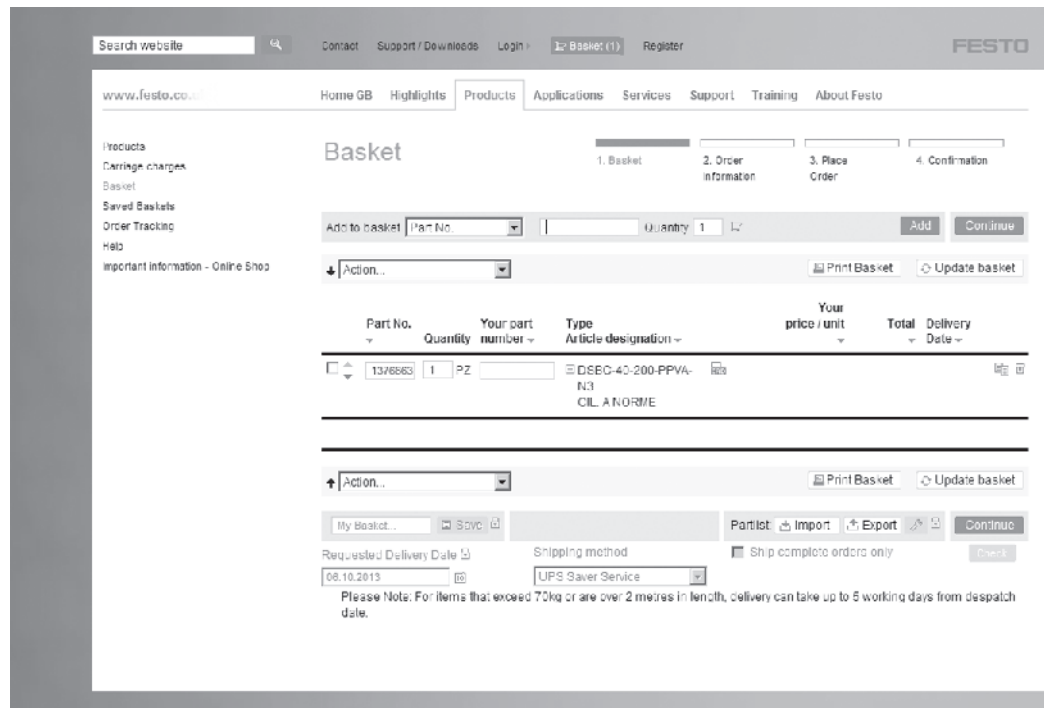

Already registered?

Then you can log in directly via www.festo.com/login or by clicking on "Login".

If you have not registered yet, open the registration form by clicking on "Register".

Further information on the Festo online shop is also available via e-mail from onlineshop@de.festo.com.

Festo – Partner for automation

Integrated information ...

... is a prerequisite for successful pneumatic and electric automation. That's why Festo sees itself as a partner to its customers and maintains a continuous dialogue with them to provide and exchange expert and comprehensive information.

Directly

- Worldwide consultation provided by more than 1,000 sales engineers and project engineers with up-to-date product and industry knowledge
- Hotlines to answer all your questions
- Experts on components, modules, systems and industries

At events

- Over 120 trade fairs around the world each year
- Expotainer – the exhibition that comes to you
- Technology days – specialised presentations and exhibits concerning current topics in the field of automation
- Automation lectures – a series of specialised presentations based on actual applications

In printed form

- trends in automation – the customer magazine with application examples, news and innovations from the world of automation technology

Documentation

- The Festo printed catalogue. Automation in a compact volume and with a clear structure
 - Industry catalogues
 - Manuals and operating instructions
 - System descriptions and product overview posters
 - Specialist literature
- Everything can be found on our Support Portal at www.festo.com

Electronically

- Always up-to-date: www.festo.com
- On the Internet or as a DVD-ROM: database-supported catalogue in 26 languages
- Spare parts catalogue
- Online shop
- Engineering tools for easier and faster design for energy-efficient solutions

Are you familiar with our basic and further training courses? Festo Didactic brings together and promotes the transfer of know-how:

Festo Didactic → 12.

After all, productivity begins with training.



The Festo subsidiary Didactic provides up-to-date expertise in the form of comprehensive and efficient qualification and consultancy services for industry and vocational training.

Training and Consulting

Festo offers a wide range of training services covering the three skills areas of technology, organisation and people and the three factors in productivity: quality, time and cost.

There are many methods and tools to achieve excellence in production. But which are the right ones?

You benefit from our project experience in many industry sectors and countries in the form of customised solutions with a focus on long-term success.



Successes in machine maintenance management include:

- Operating times increased by 40%
- Unexpected machine downtime reduced by 95%
- Productivity increased by up to 50%
- Maintenance costs reduced by up to 30%

The successes of lean manufacturing include:

- On-time deliveries increased by 50%
- Inventory reduced by 30%
- Processing time reduced by up to 80%
- Employee productivity increased by 30%
- Non-quality costs reduced by 40%

Training

We offer training courses and further education programmes for specialists and managers from industry. More than 3,000 events are attended by over 42,000 participants annually. Modular and high-quality course topics in 39 languages cover the subjects people, technology and organisation.

Consulting

The aim is always to identify and optimise value-added processes in order to make flows more efficient and prevent waste.

To achieve that, we use renowned methods and tools and we define targets by which we are measured.

Projects in the areas of:

- Production and logistics
- Management and teamwork

Selection of current training courses:

Water management training courses

A new set of training courses delivers a compact introduction into the fundamental processes of water management. By participating in practical exercises, the students gain technical knowledge and skills that can be applied immediately to day-to-day work and they become aware of how individual processes and actions in one section influence the overall system. Since all components of the training equipment largely correspond to their "real" counterparts in function and design, the exercises become an authentic and thrilling experience.

- Water purification processes in modern water works
- Safe and efficient water transport and distribution
- Key processes of wastewater transport
- Fundamentals of modern wastewater treatment processes
- Monitoring, controlling and optimising operations in water and wastewater treatment plants
- Energy optimisation in water and wastewater treatment plants

Automated systems: Technology & Control

Festo Didactic has carefully created a wide range of training courses to enable you achieve a high level of performance from your control solutions as well as to save time in commissioning and integration in your control systems. All these courses are based on practical exercises using our latest products. A vast range of industrial applications are covered in these training sessions. In order to reduce any potential downtime, extensive troubleshooting exercises play an essential role in our training workshops.

Here is a summary for the new courses:

- PLC Programming
- Trouble-shooting in control systems with PLC
- Valve terminals
- Saving energy in pneumatic systems
- Machinery safety

Handling Systems Training

Over many years robotics has been evolving very fast, providing more and better quality in production, as well as safety for the workers. Robotic systems are taking over some tasks relating to productivity, quality, risks and ergonomics. The role of robotic systems is becoming ever more important and relevant on the shop floor. Therefore, we now offer a complete set of training modules which uncover the practical and technical knowledge of robotics and motion control.

- Robotics – Basics
- Motion control solution CMCA
- Maintenance of Tripod EXPT

1 Pneumatic drives

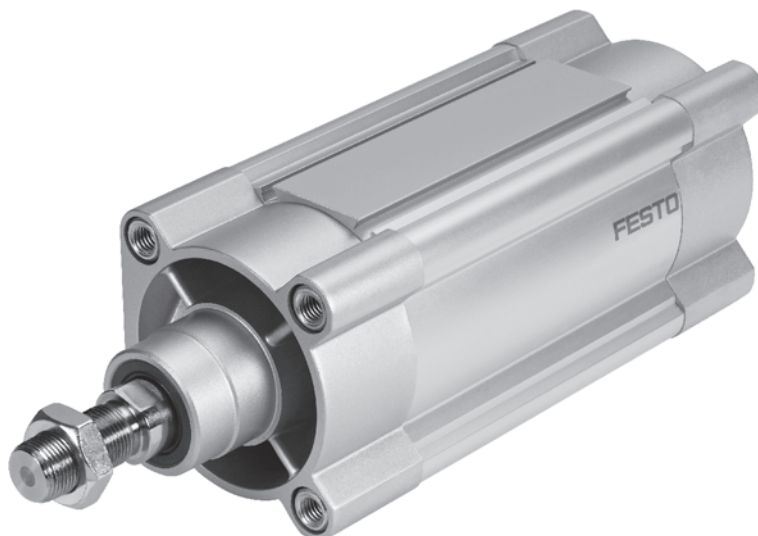

Software tool

1





Pneumatic dimensioning

Perfect simulations replace expensive actual tests. The tool is an expert system that supports you in the selection and configuration of the entire pneumatic control chain. If one parameter is changed, the program automatically adapts all the others.





This tool can be found

- in the electronic catalogue via the blue icons in the product tree underneath the search field, or
- on the website under Support in the Engineering software area, or
- on the DVD under Selection and sizing.





Standard cylinders

Type	 Compact cylinder ADN	 Compact cylinder AEN	 Compact cylinder ADNP	 Compact cylinder ADN-EL
Mode of operation	Double-acting	Pushing, single-acting, pulling	Double-acting	Double-acting
Piston diameter	12 mm, 16 mm, 20 mm, 25 mm, 32 mm, 40 mm, 50 mm, 63 mm, 80 mm, 100 mm, 125 mm	12 mm, 16 mm, 20 mm, 25 mm, 32 mm, 40 mm, 50 mm, 63 mm, 80 mm, 100 mm	20 mm, 25 mm, 32 mm, 40 mm, 50 mm	20 mm, 25 mm, 32 mm, 40 mm, 50 mm, 63 mm, 80 mm, 100 mm
Theoretical force at 6 bar, advancing	51 ... 7,363 N	56... 4,511 N	188 ... 1,178 N	188 ... 4,712 N
Stroke	1 ... 500 mm	1 ... 25 mm	5 ... 80 mm	10 ... 500 mm
Cushioning	P: elastic cushioning rings/pads at both ends, PPS: self-adjusting pneumatic end-position cushioning	P: elastic cushioning rings/pads at both ends	P: elastic cushioning rings/pads at both ends	P: elastic cushioning rings/pads at both ends
Description	<ul style="list-style-type: none"> • Piston diameter 12 ... 100 mm in accordance with ISO 21287 • Up to 50% less installation space than comparable standard cylinders to ISO 15552 • For position sensing • Piston rod with female or male thread • Wide range of variants 	<ul style="list-style-type: none"> • ISO 21287 • Up to 50% less installation space than comparable standard cylinders to ISO 15552 • For position sensing • Piston rod with female or male thread • Wide range of variants 	<ul style="list-style-type: none"> • ISO 21287 • Up to 50% less installation space than comparable standard cylinders to ISO 15552 • With polymer end cap and piston rod made from aluminium • Low-cost cylinder for standard applications • For position sensing • Piston rod with female or male thread 	<ul style="list-style-type: none"> • Standard hole pattern • With end-position locking at both ends, front or rear • For position sensing • Piston rod with female or male thread
→ Page/online	104	104	adnp	adn-el

Standard cylinders





Type	 Compact cylinder, Clean Design CDC	 Standard cylinder DSBC	 Standard cylinder DSBG	 Standard cylinder, Clean Design DSBF
Mode of operation	Double-acting	Double-acting	Double-acting	Double-acting
Piston diameter	20 mm, 25 mm, 32 mm, 40 mm, 50 mm, 63 mm, 80 mm	32 mm, 40 mm, 50 mm, 63 mm, 80 mm, 100 mm, 125 mm	32 mm, 40 mm, 50 mm, 63 mm, 80 mm, 100 mm, 125 mm, 160 mm, 200 mm	32 mm, 40 mm, 50 mm, 63 mm, 80 mm, 100 mm
Theoretical force at 6 bar, advancing	141 ... 3,016 N	415 ... 7,363 N	415 ... 18,850 N	415 ... 4,712 N
Stroke	1 ... 500 mm	1 ... 2,800 mm	1 ... 2,800 mm	1 ... 2,800 mm
Cushioning	P: elastic cushioning rings/pads at both ends	P: elastic cushioning rings/pads at both ends, PPS: self-adjusting pneumatic end-position cushioning, PPV: pneumatic cushioning, adjustable at both ends	P: elastic cushioning rings/pads at both ends, PPS: self-adjusting pneumatic end-position cushioning, PPV: pneumatic cushioning, adjustable at both ends	PPS: self-adjusting pneumatic end-position cushioning, PPV: pneumatic cushioning, adjustable at both ends
Description	<ul style="list-style-type: none"> • ISO 21287 • Up to 50% less installation space than comparable standard cylinders to ISO 15552 • Easy-to-clean design • Increased corrosion protection • For position sensing • Wide range of variants • Piston rod with female or male thread 	<ul style="list-style-type: none"> • ISO 15552 (ISO 6431, VDMA 24562) • With self-adjusting pneumatic end-position cushioning PPS – adapts perfectly to changes in load and speed • For position sensing • High flexibility thanks to the wide range of variants • Extensive range of accessories makes it possible to install the cylinder virtually anywhere 	<ul style="list-style-type: none"> • ISO 15552 (ISO 6431, VDMA 24562) • Sturdy tie rod design • For contactless position sensing • Available with protection against rotation • Extensive range of accessories makes it possible to install the cylinder virtually anywhere 	<ul style="list-style-type: none"> • ISO 15552 with increased corrosion protection • Resistant to conventional cleaning agents • FDA-approved lubrication and sealing on the basic design • Long service life thanks to optional seal for unlubricated operation • Hygienic mounting of the sensors possible • Comprehensive range of mounting accessories for just about every type of installation
→ Page/online	cdc	35	46	56

Standard cylinders



Type	 Standard cylinder DNC	 Standard cylinder DNG	 Standard cylinder DNGZK	 Standard cylinder DNGZS
Mode of operation	Double-acting	Double-acting	Double-acting	Double-acting
Piston diameter	32 mm, 40 mm, 50 mm, 63 mm, 80 mm, 100 mm, 125 mm	160 mm, 200 mm, 250 mm, 320 mm	160 mm, 200 mm	250 mm, 320 mm
Theoretical force at 6 bar, advancing	415 ... 7,363 N	11,310 ... 48,250 N	12,064 ... 18,850 N	29,450 ... 48,250 N
Stroke	2 ... 2,000 mm	1 ... 2,000 mm	1 ... 2,000 mm	1 ... 1,100 mm
Cushioning	P: elastic cushioning rings/pads at both ends, PPV: pneumatic cushioning, adjustable at both ends	PPV: pneumatic cushioning, adjustable at both ends	PPV: pneumatic cushioning, adjustable at both ends	PPV: pneumatic cushioning, adjustable at both ends
Description	<ul style="list-style-type: none"> • ISO 15552 (ISO 6431, VDMA 24562) • For position sensing • Saves up to 11% on fitting space compared with ordinary standard cylinders • Wide range of variants • Profile slot for proximity sensors on three sides • No protruding proximity sensors 	<ul style="list-style-type: none"> • ISO 15552 (ISO 6431, VDMA 24562) • Sturdy tie rod design • Proximity sensors mounted using kit • Wide range of accessories 	<ul style="list-style-type: none"> • ISO 15552 (ISO 6431, VDMA 24562) • With adjustable central trunnion mounting • Sturdy tie rod design • Proximity sensors mounted using kit • Wide range of accessories 	<ul style="list-style-type: none"> • ISO 15552 (ISO 6431, VDMA 24562) • With fixed central trunnion mounting • Sturdy tie rod design • Proximity sensors mounted using kit • Wide range of accessories
→ Page/online	63	dng	dngzk	dngzs

Standard cylinders



1

Type	 Standard cylinder DSNU	 Standard cylinder ESNU	 Standard cylinder DSNUP	 Standard cylinder DSN, ESN
Mode of operation	Double-acting	Pushing, single-acting	Double-acting	Double-acting, pushing, single-acting
Piston diameter	8 mm, 10 mm, 12 mm, 16 mm, 20 mm, 25 mm	8 mm, 10 mm, 12 mm, 16 mm, 20 mm, 25 mm	16 mm, 20 mm, 25 mm	8 mm, 10 mm, 12 mm, 16 mm, 20 mm, 25 mm
Theoretical force at 6 bar, advancing	23 ... 295 N	19 ... 271 N	121 ... 295 N	24 ... 294.5 N
Stroke	1 ... 500 mm	1 ... 50 mm	25 ... 100 mm	1 ... 500 mm
Cushioning	P: elastic cushioning rings/pads at both ends, PPS: self-adjusting pneumatic end-position cushioning, PPV: pneumatic cushioning, adjustable at both ends	P: elastic cushioning rings/pads at both ends	P: elastic cushioning rings/pads at both ends	P: elastic cushioning rings/pads at both ends, PPV: pneumatic cushioning, adjustable at both ends
Description	<ul style="list-style-type: none"> • ISO 6432 • For position sensing • Wide range of variants • Good running performance and long service life • Piston rod with female or male thread 	<ul style="list-style-type: none"> • ISO 6432 • For position sensing • Wide range of variants • Good running performance and long service life • Piston rod with female or male thread 	<ul style="list-style-type: none"> • ISO 6432 • Cost-optimised round cylinder • Wrought aluminium alloy cylinder barrel • Polyamide bearing and end caps • For position sensing 	<ul style="list-style-type: none"> • ISO 6432 • Good running performance and long service life • Piston rod with female or male thread
→ Page/online	71	82	77	80





Round cylinders

Type	 Round cylinder DSNU	 Round cylinder ESNU	 Round cylinder DGS
Mode of operation	Double-acting	Pushing, single-acting	Double-acting
Piston diameter	32 mm, 40 mm, 50 mm, 63 mm	32 mm, 40 mm, 50 mm, 63 mm	12 mm, 16 mm, 20 mm, 25 mm, 40 mm
Theoretical force at 6 bar, advancing	482.5 ... 1,870.3 N	406 ... 1,765 N	68 ... 754 N
Stroke	1 ... 500 mm	1 ... 50 mm	1 ... 2,000 mm
Cushioning	P: elastic cushioning rings/pads at both ends, PPS: self-adjusting pneumatic end-position cushioning, PPV: pneumatic cushioning, adjustable at both ends	P: elastic cushioning rings/pads at both ends	P: elastic cushioning rings/pads at both ends, PPV: pneumatic cushioning, adjustable at both ends; no cushioning
Description	<ul style="list-style-type: none"> • For position sensing • Wide range of variants • Good running performance and long service life • Piston rod with female or male thread 	<ul style="list-style-type: none"> • For position sensing • Wide range of variants • Good running performance and long service life • Piston rod with female or male thread 	<ul style="list-style-type: none"> • Wide range of variants • Piston rod with male thread • For position sensing
→ Page/online	91	97	dgs

Round cylinders





Type	 Round cylinder DG, EG	 Round cylinder EG-PK
Mode of operation	Pushing, single-acting	Pushing, single-acting
Piston diameter	2.5 mm, 4 mm, 6 mm, 12 mm, 16 mm, 25 mm	2.5 mm, 4 mm, 6 mm
Theoretical force at 6 bar, advancing	1.9 ... 215 N	1.7 ... 14 N
Stroke	1 ... 80 mm	5... 25 mm
Cushioning	At one end, no cushioning, non-adjustable	No cushioning
Description	<ul style="list-style-type: none"> • Miniature cylinder • Good running performance • Piston rod with or without male thread 	<ul style="list-style-type: none"> • Micro cylinder with supply port • Barbed fitting for plastic tubing with standard I.D.
→ Page/online	dg	eg-pk

Stainless steel cylinders



Type	 Standard cylinder CRDSNU	 Round cylinder CRDSNU	 Standard cylinder CRDNG, CRDNGS	 Round cylinder CRHD
Mode of operation	Double-acting	Double-acting	Double-acting	Double-acting
Piston diameter	12 mm, 16 mm, 20 mm, 25 mm	32 mm, 40 mm, 50 mm, 63 mm	32 mm, 40 mm, 50 mm, 63 mm, 80 mm, 100 mm, 125 mm	32 mm, 40 mm, 50 mm, 63 mm, 80 mm, 100 mm
Theoretical force at 6 bar, advancing	68 ... 295 N	483 ... 1,870 N	483 ... 7,363 N	483 ... 4,712 N
Stroke	1 ... 500 mm	1 ... 500 mm	10 ... 2,000 mm	10 ... 500 mm
Cushioning	P: elastic cushioning rings/pads at both ends, PPS: self-adjusting pneumatic end-position cushioning, PPV: pneumatic cushioning, adjustable at both ends	P: elastic cushioning rings/pads at both ends, PPS: self-adjusting pneumatic end-position cushioning, PPV: pneumatic cushioning, adjustable at both ends	PPV: pneumatic cushioning, adjustable at both ends	PPV: pneumatic cushioning, adjustable at both ends
Description	<ul style="list-style-type: none"> • ISO 6432 • Corrosion-resistant in harsh environmental conditions • Easy-to-clean design • Long service life thanks to optional unlubricated seal • For position sensing • Wide range of variants • Wide range of accessories 	<ul style="list-style-type: none"> • Corrosion-resistant in harsh environmental conditions • Easy-to-clean design • Long service life thanks to optional unlubricated seal • For position sensing • Wide range of variants • Wide range of accessories 	<ul style="list-style-type: none"> • ISO 15552 (ISO 6431, VDMA 24562) • Corrosion-resistant in harsh environmental conditions • Easy-to-clean design • Threaded mounting, mounting via accessories • For position sensing • Variants: through piston rod, heat-resistant design 	<ul style="list-style-type: none"> • Corrosion-resistant in harsh environmental conditions • Easy-to-clean design, optimised for exacting demands • Great flexibility thanks to different end caps • For position sensing • Piston rod with male thread
→ Page/online	crdsnu-12	crdsnu-32	crdng	crhd

Short-stroke cylinders and compact cylinders



1

Type	 Compact cylinder ADN	 Compact cylinder AEN	 Compact cylinder ADNGF	 Compact cylinder ADNP
Mode of operation	Double-acting	Pushing, single-acting, pulling	Double-acting	Double-acting
Piston diameter	12 mm, 16 mm, 20 mm, 25 mm, 32 mm, 40 mm, 50 mm, 63 mm, 80 mm, 100 mm, 125 mm	12 mm, 16 mm, 20 mm, 25 mm, 32 mm, 40 mm, 50 mm, 63 mm, 80 mm, 100 mm	12 mm, 16 mm, 20 mm, 25 mm, 32 mm, 40 mm, 50 mm, 63 mm, 80 mm, 100 mm	20 mm, 25 mm, 32 mm, 40 mm, 50 mm
Theoretical force at 6 bar, advancing	51 ... 7,363 N	56 ... 4,511 N	68 ... 4,712 N	188 ... 1,178 N
Stroke	1 ... 500 mm	1 ... 25 mm	1 ... 400 mm	5 ... 80 mm
Cushioning	P: elastic cushioning rings/pads at both ends, PPS: self-adjusting pneumatic end-position cushioning	P: elastic cushioning rings/pads at both ends	P: elastic cushioning rings/pads at both ends, PPS: self-adjusting pneumatic end-position cushioning	P: elastic cushioning rings/pads at both ends
Description	<ul style="list-style-type: none"> Piston diameter 12 ... 100 mm in accordance with ISO 21287 Up to 50% less installation space than comparable standard cylinders to ISO 15552 For position sensing Piston rod with female or male thread Wide range of variants 	<ul style="list-style-type: none"> ISO 21287 Up to 50% less installation space than comparable standard cylinders to ISO 15552 For position sensing Piston rod with female or male thread Wide range of variants 	<ul style="list-style-type: none"> Mounting hole pattern to ISO 21287 Piston rod secured against rotation by means of guide rod and yoke plate Plain-bearing guide For position sensing Available with through piston rod 	<ul style="list-style-type: none"> ISO 21287 Up to 50% less installation space than comparable standard cylinders to ISO 15552 With polymer end cap and piston rod made from aluminium Low-cost cylinder for standard applications For position sensing Piston rod with female or male thread
→ Page/online	104	104	adngf	adnp



Short-stroke cylinders and compact cylinders

Type	 Compact cylinder ADN-EL	 Compact cylinder CDC	 Short-stroke cylinder ADVC, AEVC
Mode of operation	Double-acting	Double-acting	Double-acting, pushing, single-acting
Piston diameter	20 mm, 25 mm, 32 mm, 40 mm, 50 mm, 63 mm, 80 mm, 100 mm	20 mm, 25 mm, 32 mm, 40 mm, 50 mm, 63 mm, 80 mm	4 mm, 6 mm, 10 mm, 12 mm, 16 mm, 20 mm, 25 mm, 32 mm, 40 mm, 50 mm, 63 mm, 80 mm, 100 mm
Theoretical force at 6 bar, advancing	188 ... 4,712 N	141 ... 3,016 N	4.9 ... 4,712 N
Stroke	10 ... 500 mm	1 ... 500 mm	2.5 ... 25 mm
Cushioning	P: elastic cushioning rings/pads at both ends	P: elastic cushioning rings/pads at both ends	P: elastic cushioning rings/pads at both ends
Description	<ul style="list-style-type: none"> Standard hole pattern With end-position locking at both ends, front or rear For position sensing Piston rod with female or male thread 	<ul style="list-style-type: none"> ISO 21287 Up to 50% less installation space than comparable standard cylinders to ISO 15552 Easy-to-clean design Increased corrosion protection For position sensing Wide range of variants Piston rod with female or male thread 	<ul style="list-style-type: none"> Short-stroke cylinder with standard hole pattern to VDMA 24562 from diameter 32 mm Little space required High clamping forces in a compact size For position sensing via proximity sensor for T-slot and for C-slot Piston rod with female or male thread
→ Page/online	adn-el	cdc	123



Short-stroke cylinders and compact cylinders

Type	 Compact cylinder ADVU, AEVU, AEVUZ	 Compact cylinder ADVUL	 Flat cylinder DZF
Mode of operation	Double-acting, pushing, single-acting, pulling	Double-acting	Double-acting
Piston diameter	12 mm, 16 mm, 20 mm, 25 mm, 32 mm, 40 mm, 50 mm, 63 mm, 80 mm, 100 mm, 125 mm	12 mm, 16 mm, 20 mm, 25 mm, 32 mm, 40 mm, 50 mm, 63 mm, 80 mm, 100 mm	Equivalent diameter, 12 mm, 18 mm, 25 mm, 32 mm, 40 mm, 50 mm, 63 mm
Theoretical force at 6 bar, advancing	42 ... 7,363 N	51 ... 4,712 N	51 ... 1,870 N
Stroke	1 ... 2,000 mm	1 ... 400 mm	1 ... 320 mm
Cushioning	P: elastic cushioning rings/pads at both ends	P: elastic cushioning rings/pads at both ends	P: elastic cushioning rings/pads at both ends
Description	<ul style="list-style-type: none"> • 50% less installation space than comparable standard cylinders to ISO 15552 • For position sensing • Wide range of variants • Piston rod with female or male thread 	<ul style="list-style-type: none"> • Piston rod secured against rotation by means of guide rod and yoke plate • For position sensing • Plain-bearing guide • For position sensing • Available with through piston rod 	<ul style="list-style-type: none"> • Extremely flat design • Protected against rotation thanks to special piston shape • Ideal for manifold assembly • Wide range of mounting options • For position sensing • Piston rod with female or male thread
→ Page/online	advu	advul	dzf



Short-stroke cylinders and compact cylinders

Type	 Flat cylinder DZH	 Flat cylinder EZH
Mode of operation	Double-acting	Pushing, single-acting
Piston diameter	Equivalent diameter, 16 mm, 20 mm, 25 mm, 32 mm, 40 mm, 50 mm, 63 mm	Equivalent diameter, 3 mm, 6 mm, 12 mm, 22 mm
Theoretical force at 6 bar, advancing	104 ... 1,870 N	3.8 ... 205 N
Stroke	1 ... 1,000 mm	10 ... 50 mm
Cushioning	PPV: pneumatic cushioning, adjustable at both ends	No cushioning
Description	<ul style="list-style-type: none"> • Flat design • Protected against rotation thanks to special piston shape • Ideal for manifold assembly • Wide range of mounting options • For position sensing • Piston rod with male thread 	<ul style="list-style-type: none"> • Extremely flat design • Protected against rotation thanks to special piston shape • Wide range of mounting options • For position sensing
→ Page/online	dzh	ezh



1 Cartridge cylinders and multimount cylinders

Type	 Multimount cylinder DMM, EMM, DMML, EMML	 Cartridge cylinder EGZ	 Flanged cylinder DFK, EFK
Mode of operation	Double-acting, pushing, single-acting	Pushing, single-acting	Double-acting, single-acting, pushing
Piston diameter	10 mm, 16 mm, 20 mm, 25 mm, 32 mm	6 mm, 10 mm, 16 mm	8 mm, 10 mm, 12 mm, 16 mm, 20 mm, 25 mm
Theoretical force at 6 bar, advancing	37 ... 483 N	13.9 ... 109 N	30 ... 295 N
Stroke	1 ... 50 mm	5 ... 15 mm	10 ... 80 mm
Cushioning	P: elastic cushioning rings/pads at both ends	No cushioning	P: elastic cushioning rings/pads at both ends
Description	<ul style="list-style-type: none"> • Wide range of mounting options • Wide selection of piston rod variants • For position sensing • Piston rod with male thread 	<ul style="list-style-type: none"> • Minimal fitting space • Installation with or without mounting components • Piston rod with male thread 	<ul style="list-style-type: none"> • Polymer design • Integrated mounting flange and connection • Piston rod with male thread
→ Page/online	dmm	egz	dfk

Cylinders with clamping unit

Type	 Compact cylinder with clamping unit ADN-KP	 Compact cylinder with clamping unit DSNU-KP	 Round cylinder with clamping cartridge DSNU-KP
Mode of operation	Double-acting	Double-acting	Double-acting
Piston diameter	20 mm, 25 mm, 32 mm, 40 mm, 50 mm, 63 mm, 80 mm, 100 mm	8 mm, 10 mm, 12 mm, 16 mm, 20 mm, 25 mm	32 mm, 40 mm, 50 mm, 63 mm
Theoretical force at 6 bar, advancing	188... 4,712 N	30 ... 295 N	482.5 ... 1,870.3 N
Stroke	10 ... 500 mm	1 ... 500 mm	1 ... 500 mm
Cushioning	P: elastic cushioning rings/pads at both ends	P: elastic cushioning rings/pads at both ends, PPS: self-adjusting pneumatic end-position cushioning, PPV: pneumatic cushioning, adjustable at both ends	P: elastic cushioning rings/pads at both ends, PPS: self-adjusting pneumatic end-position cushioning, PPV: pneumatic cushioning, adjustable at both ends
Description	<ul style="list-style-type: none"> • Mounting hole pattern to ISO 21287 • Piston rod can be held or clamped in any position during clamping, processing or handling operations • For position sensing • Piston rod with female or male thread 	<ul style="list-style-type: none"> • Mounting hole pattern to ISO 6432 • Piston rod can be held or clamped in any position • Piston rod can be held in position for long periods even with alternating loads, fluctuating operating pressure or leaks in the system • For position sensing 	<ul style="list-style-type: none"> • Piston rod can be held or clamped in any position • Piston rod can be held in position for long periods even with alternating loads, fluctuating operating pressure or leaks in the system • For position sensing
→ Page/online	109	78	95

Cylinders with clamping unit



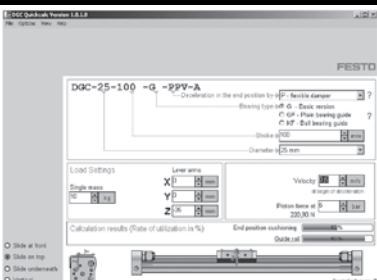

Type	 Standard cylinder DNC-KP	 Cylinder with clamping unit DNCKE, DNCKE-S
Mode of operation	Double-acting	Double-acting
Piston diameter	32 mm, 40 mm, 50 mm, 63 mm, 80 mm, 100 mm, 125 mm	40 mm, 63 mm, 100 mm
Theoretical force at 6 bar, advancing	415 ... 7,363 N	754 ... 4,712 N
Stroke	10 ... 2,000 mm	10 ... 2,000 mm
Cushioning	P: elastic cushioning rings/pads at both ends, PPV: pneumatic cushioning, adjustable at both ends	PPV: pneumatic cushioning, adjustable at both ends
Description	<ul style="list-style-type: none"> • Piston rod can be held or clamped in any position • Piston rod can be held in position for long periods even with alternating loads, fluctuating operating pressure or leaks in the system • Mounting hole pattern to ISO 15552 • For position sensing • Wide range of variants • Piston rod with female or male thread 	<ul style="list-style-type: none"> • Cylinder for holding, clamping and braking • Mounting hole pattern to ISO 15552 • Variant DNCKE-...-S approved for use in safety-oriented parts of control systems • Piston rod can be clamped in any position • For position sensing • Piston rod with male thread
→ Page/online	dnc-kp	dncke

Software tool



<p>Calculation guide for pneumatic linear drives</p>		<p>Festo's linear drives are known for delivering maximum force in minimum space. By specifying the project parameters such as mass or force, mounting position and travel, the software tool determines the optimum drive configuration for you.</p>	<p>This tool can be found</p> <ul style="list-style-type: none"> • in the electronic catalogue via the blue icons in the product tree underneath the search field, or • on the website under Support in the Engineering software area, or • on the DVD under Selection and sizing.
--	--	---	---

Rodless cylinders

1

Type	 Linear drive DGC-K	 Linear drive DGC-G, DGC-GF, DGC-KF	 Linear drive with heavy-duty guide DGC-HD	 Linear drive DGP, DGPL
Piston diameter	18 mm, 25 mm, 32 mm, 40 mm, 50 mm, 63 mm, 80 mm	8 mm, 12 mm, 18 mm, 25 mm, 32 mm, 40 mm, 50 mm, 63 mm	18 mm, 25 mm, 40 mm	18 mm, 25 mm, 32 mm, 40 mm, 50 mm, 63 mm, 80 mm
Theoretical force at 6 bar, advancing	153 ... 3,016 N	30 ... 1,870 N	153 ... 754 N	153 ... 3,016 N
Stroke	1 ... 8,500 mm	1 ... 8,500 mm	1 ... 5,000 mm	10 ... 3,000 mm
Cushioning	PPV: pneumatic cushioning, adjustable at both ends	P: elastic cushioning rings/pads at both ends, PPV: pneumatic cushioning, adjustable at both ends, YSR: shock absorber, hard characteristic curve, YSRW: shock absorber, soft characteristic curve	YSR: shock absorber, hard characteristic curve, YSRW: shock absorber, soft characteristic curve	PPV: pneumatic cushioning, adjustable at both ends, YSR: shock absorber, hard characteristic curve
Position sensing	Via proximity sensor	Via proximity sensor	Via proximity sensor	Via proximity sensor, with attached displacement encoder, with integrated displacement encoder
Description	<ul style="list-style-type: none"> • Compact design: 30% narrower than the basic design DGC-G • Low moving dead weight • Without external guide, for simple drive functions • Easy assembly and installation • Fully interchangeable with the linear drive DGP 	<ul style="list-style-type: none"> • Basic design, plain or recirculating ball bearing guide • Optimised mounting options • High-precision guide • Optimised sealing system • All settings accessible from one side • Available with variable end stops and intermediate position module • Exchangeable with DGPL thanks to foot mountings • Software tool available for bearing calculation • Optional: NSF-H1 lubricant for the food industry • Optional: clamping unit for holding loads 	<ul style="list-style-type: none"> • For maximum loads and torques thanks to duo rail guide • Very good operating behaviour under torque load • Long service life • Ideal as a basic axis for linear gantries and cantilever axes • Excellent price/performance ratio • Wide range of options for mounting on drives 	<ul style="list-style-type: none"> • Little space required • High precision and load capacity • Basic design, plain, recirculating ball bearing or heavy-duty guide • Wide range of variants
→ Page/online	dgc	143	143	dgp

Rodless cylinders



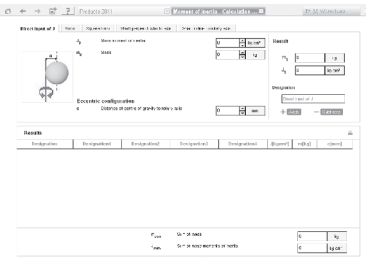

Type	 Linear drive SLG	 Linear drive DGO	 Linear drive SLM
Piston diameter	8 mm, 12 mm, 18 mm	12 mm, 16 mm, 20 mm, 25 mm, 32 mm, 40 mm	12 mm, 16 mm, 20 mm, 25 mm, 32 mm, 40 mm
Theoretical force at 6 bar, advancing	30 ... 153 N	68 ... 754 N	68 ... 754 N
Stroke	100 ... 900 mm	10 ... 4,000 mm	10 ... 1,500 mm
Cushioning	P: elastic cushioning rings/pads at both ends, YSR: shock absorber, hard characteristic curve	P: elastic cushioning rings/pads at both ends, PPV: pneumatic cushioning, adjustable at both ends	P: elastic cushioning rings/pads at both ends, YSR: shock absorber, hard characteristic curve
Position sensing	Via proximity sensor	Via proximity sensor	Via proximity sensor, via inductive sensor
Description	<ul style="list-style-type: none"> • Extremely flat design • Integrated precision guide • Adjustable end stops • Choice of supply ports • Available with intermediate position module 	<ul style="list-style-type: none"> • Magnetic force transmission • Pressure-tight and zero leakage • Dirt-proof and dust-proof 	<ul style="list-style-type: none"> • Recirculating ball bearing guide • Magnetic force transmission • Individual choice of end-position cushioning and sensing
→ Page/online	slg	dgo	slm

Software tool



1

Mass moment of inertia 	<p>Juggling pencils and pocket calculators is now a thing of the past. No matter whether you have discs, blocks, push-on flanges, grippers, etc., this tool does the job of calculating all the mass moments of inertia. Just save, send or print and you're finished.</p>	<p>This tool can be found</p> <ul style="list-style-type: none"> • in the electronic catalogue via the blue icons in the product tree underneath the search field, or • on the website under Support in the Engineering software area, or • on the DVD under Selection and sizing.
--	--	---

Semi-rotary drives



Type	 Semi-rotary drive DRRD	 Swivel module DSM, DSM-B, DSM-HD-B	 Semi-rotary drive DSR, DSRL	 Semi-rotary drive DRQ
Size	16, 20, 25, 32, 35, 40	6, 8, 10, 12, 16, 25, 32, 40, 63	10, 12, 16, 25, 32, 40	16, 20, 25, 32, 40, 50, 63, 80, 100
Torque at 6 bar	1.6 ... 24.1 Nm	0.15 ... 80 Nm	0.5 ... 20 Nm	0.5 ... 150 Nm
Swivel angle	180°	0 ... 270°	0 ... 180°	90 ... 360°
Permissible mass moment of inertia	0.0175 ... 42 kgcm ²	6.5 ... 5,000 kgcm ²	0 .. 150 kgcm ²	2 ... 2,000 kgcm ²
Position sensing	Via proximity sensor	Via proximity sensor, none	None	Via proximity sensor
Description	<ul style="list-style-type: none"> • With twin pistons based on the rack and pinion principle • Very high accuracy in the end positions • Very high bearing load capacity • Very good axial run-out at the flanged shaft 	<ul style="list-style-type: none"> • Force transmitted directly to the drive shaft via a rotary vane • With spigot shaft, hollow flanged shaft, tandem rotary vane and spigot shaft, tandem rotary vane and flanged shaft or heavy-duty bearing (HD) 	<ul style="list-style-type: none"> • Force transmitted directly to the drive shaft via a rotary vane • With spigot or hollow flanged shaft 	<ul style="list-style-type: none"> • Conversion of linear motion into rotary motion via a backlash-compensating gear unit • High precision thanks to backlash-free transmission of force from the gear rack to the pinion
→ Page/online	181	193	dsr	drq

Semi-rotary drives

Type	 Semi-rotary drive DRQD, DRQD-B	 Swivel/linear drive unit DSL-B
Size	6, 8, 12, 16, 20, 25, 32, 40, 50	16, 20, 25, 32, 40
Torque at 6 bar	0.16 ... 78.6 Nm	1.25 ... 20 Nm
Swivel angle	0 ... 360°	0 ... 272°
Permissible mass moment of inertia	0.075 ... 11,000 kgcm ²	0.35 ... 40 kgcm ²
Position sensing	Via proximity sensor	Via proximity sensor
Description	<ul style="list-style-type: none"> • With twin pistons based on the rack and pinion principle • High accuracy • Extremely good rigidity • Wide range of variants • With spigot or flanged shaft 	<ul style="list-style-type: none"> • Rotary and linear motion can be controlled individually or simultaneously • High repetition accuracy • With plain or recirculating ball bearing guide • Through piston rod
→ Page/online	224	dsl

1





Tandem and high-force cylinders

		
Type	High-force cylinder ADNH	Tandem cylinder DNCT
Piston diameter	25 mm, 40 mm, 63 mm, 100 mm	32 mm, 40 mm, 50 mm, 63 mm, 80 mm, 100 mm, 125 mm
Theoretical force at 6 bar, advancing	1,036 ... 18,281 N	898 ... 14,244 N
Stroke	1 ... 150 mm	2 ... 500 mm
Description	<ul style="list-style-type: none"> • Mounting hole pattern to ISO 21287 • Max. 4 cylinders can be combined • Thrust increase • Only 2 connections are required to pressurise all cylinders • For position sensing • Piston rod with female or male thread 	<ul style="list-style-type: none"> • Mounting hole pattern to ISO 15552 • Max. 2 cylinders can be combined • Thrust and return force increase • For position sensing • Piston rod with male thread
→ Page/online	adnh	dnct



Multi-position cylinders

	
Type	Multi-position cylinder ADNMM
Piston diameter	25 mm, 40 mm, 63 mm, 100 mm
Theoretical force at 6 bar, advancing	295 ... 4,712 N
Max. total of all individual strokes	1,000 ... 2,000 mm
Description	<ul style="list-style-type: none"> • Mounting hole pattern to ISO 21287 • Piston rod with female or male thread • 2 ... 5 cylinders can be combined • Max. 5 positions can be approached • Piston rod with female or male thread • For position sensing
→ Page/online	adnm





Drives with slides

Type	 Mini slide DGSC	 Mini slide DGSL	 Mini slide SLF	 Mini slide SLS
Piston diameter	6 mm	6 mm, 8 mm, 10 mm, 12 mm, 16 mm, 20 mm, 25 mm, 32 mm	6 mm, 10 mm, 16 mm	6 mm, 10 mm, 16 mm
Theoretical force at 6 bar, advancing	17 N	17 ... 483 N	17 ... 121 N	17 ... 121 N
Stroke	10 mm	10 ... 200 mm	10 ... 80 mm	5 ... 30 mm
Cushioning	P: elastic cushioning rings/pads at both ends	E: short elastic cushioning rings/pads at both ends, P1: elastic cushioning rings/pads at both ends with fixed stop, P: elastic cushioning rings/pads at both ends, Y3: progressive shock absorber at both ends	P: elastic cushioning rings/pads at both ends	P: elastic cushioning rings/pads at both ends
Position sensing	None	Via proximity sensor	Via proximity sensor	Via proximity sensor
Description	<ul style="list-style-type: none"> • Smallest guided slide unit on the market • Precision ball bearing cage guide: reliable and high-quality process • Long service life thanks to housing made from high-alloy steel • Low break-away pressure and uniform movement thanks to minimal friction from guide and seal 	<ul style="list-style-type: none"> • High load capacity and positioning accuracy • Maximum movement precision thanks to ground-in ball bearing cage guide • Maximum flexibility thanks to eight sizes • Reliable in the event of pressure drop thanks to clamping cartridge or end-position locking • Versatile mounting options thanks to piggy-back • Compact 	<ul style="list-style-type: none"> • Flat design • Ball bearing guide • Versatile mounting options • Easy adjustment of end positions 	<ul style="list-style-type: none"> • Slim design • Ball bearing guide • Versatile mounting options
→ Page/online	dgsc	250	slf	sls





Drives with slides

Type	 Mini slide SLT	 Slide unit SPZ
Piston diameter	6 mm, 10 mm, 16 mm, 20 mm, 25 mm	10 mm, 16 mm, 20 mm, 25 mm, 32 mm
Theoretical force at 6 bar, advancing	34 ... 590 N	60 ... 724 N
Stroke	10 ... 200 mm	10 ... 100 mm
Cushioning	CC: shock absorber at both ends, P: elastic cushioning rings/pads at both ends	P: elastic cushioning rings/pads at both ends
Position sensing	Via proximity sensor	Via proximity sensor
Description	<ul style="list-style-type: none"> • Powerful twin piston drive • Ball bearing guide • Versatile mounting options • Easy adjustment of end positions 	<ul style="list-style-type: none"> • Twin piston • High force with excellent protection against rotation • Widely spaced piston rods for high load capacity • Plain or recirculating ball bearing guide
→ Page/online	slt	spz

1 Drives with guide rods

Type	 Guided drive DGRF	 Guided drive DFP	 Compact cylinder ADNGF	 Compact cylinder ADVUL
Piston diameter	20 mm, 25 mm, 32 mm, 40 mm, 50 mm, 63 mm	10 mm, 16 mm, 25 mm, 32 mm, 50 mm, 80 mm	12 mm, 16 mm, 20 mm, 25 mm, 32 mm, 40 mm, 50 mm, 63 mm, 80 mm, 100 mm	12 mm, 16 mm, 20 mm, 25 mm, 32 mm, 40 mm, 50 mm, 63 mm, 80 mm, 100 mm
Theoretical force at 6 bar, advancing	189 ... 1,870 N	31 ... 3,016 N	68 ... 4,712 N	51 ... 4,712 N
Stroke	10 ... 400 mm	25 ... 500 mm	1 ... 400 mm	1 ... 400 mm
Cushioning	P: elastic cushioning rings/pads at both ends, PPV: pneumatic cushioning, adjustable at both ends	P: elastic cushioning rings/pads at both ends, PPV: pneumatic cushioning, adjustable at both ends	P: elastic cushioning rings/pads at both ends, PPS: self-adjusting pneumatic end-position cushioning	P: elastic cushioning rings/pads at both ends
Position sensing	Via proximity sensor	Via proximity sensor	Via proximity sensor	Via proximity sensor
Description	<ul style="list-style-type: none"> Designed completely according to Clean Design criteria Long service life thanks to optional seal for unlubricated operation FDA-approved lubrication and sealing on the basic design Good corrosion resistance and smooth surfaces for easy cleaning Hygienic mounting of the sensors possible Compact design with high guidance accuracy and load capacity 	<ul style="list-style-type: none"> High-precision guiding thanks to recirculating ball bearing guide on piston rod Able to absorb high torques Saves space in comparison with standard cylinders 	<ul style="list-style-type: none"> Mounting hole pattern to ISO 21287 Piston rod secured against rotation by means of guide rod and yoke plate Plain-bearing guide Available with through piston rod 	<ul style="list-style-type: none"> Piston rod secured against rotation by means of guide rod and yoke plate For position sensing Plain-bearing guide Available with through piston rod
→ Page/online	dgrf	dfp	adngf	advul

Drives with guide rods

Type	 Mini guided drive DFC	 Guided drive DFM, DFM-B	 Twin-piston cylinder DPZ	 Twin-piston cylinder DPZJ
Piston diameter	4 mm, 6 mm, 10 mm	12 mm, 16 mm, 20 mm, 25 mm, 32 mm, 40 mm, 50 mm, 63 mm, 80 mm, 100 mm	10 mm, 16 mm, 20 mm, 25 mm, 32 mm	10 mm, 16 mm, 20 mm, 25 mm, 32 mm
Theoretical force at 6 bar, advancing	7.5 ... 47 N	51 ... 4,712 N	94 ... 966 N	60 ... 724 N
Stroke	5 ... 30 mm	10 ... 400 mm	10 ... 100 mm	10 ... 100 mm
Cushioning	P: elastic cushioning rings/pads at both ends	P: elastic cushioning rings/pads at both ends, PPV: pneumatic cushioning, adjustable at both ends, YSRW: shock absorber, soft characteristic curve	P: elastic cushioning rings/pads at both ends	P: elastic cushioning rings/pads at both ends
Position sensing	Via proximity sensor, none	Via proximity sensor	Via proximity sensor	Via proximity sensor
Description	<ul style="list-style-type: none"> Smallest guided drive High precision and load capacity Minimal space requirement Drive and guide unit in a single housing Plain or recirculating ball bearing guide 	<ul style="list-style-type: none"> Drive and guide unit in a single housing Plain or recirculating ball bearing guide High resistance to torques and lateral forces Wide range of mounting options Wide range of variants 	<ul style="list-style-type: none"> Twin pistons provide twice the force in half the space Plain or recirculating ball bearing guide Precision stroke adjustment in the end position 	<ul style="list-style-type: none"> With yoke plate on rear of cylinder for higher lateral forces and precision Twin pistons provide twice the force in half the space Plain or recirculating ball bearing guide Precision stroke adjustment in the end position
→ Page/online	dfc	271	dpz	dpzj



Drives with guide rods

	
Type	Linear unit SLE
Piston diameter	10 mm, 16 mm, 20 mm, 25 mm, 32 mm, 40 mm, 50 mm
Theoretical force at 6 bar, advancing	47 ... 1,178 N
Stroke	10 ... 500 mm
Cushioning	YSR: shock absorber, hard characteristic curve
Position sensing	Via proximity sensor, via inductive sensor
Description	<ul style="list-style-type: none"> • Combination of guide unit and standard cylinder • Multi-axis and drive combinations • Recirculating ball bearing guide
→ Page/online	sle

Linear modules

	
Type	Linear module HMP
Mode of operation	Double-acting
Piston diameter	16 mm, 20 mm, 25 mm, 32 mm
Stroke	50 ... 400 mm
Theoretical force at 6 bar, advancing	121 ... 483 N
Position sensing	Via proximity sensor
Description	<ul style="list-style-type: none"> • Precision, backlash-free guidance • High rigidity with a long stroke • Infinitely adjustable end stops • Flexible thanks to intermediate position • Adjustable end-position cushioning
→ Page/online	hmp

Stopper cylinders

		
Type	Stopper cylinder DFST	Stopper cylinder STA, STAF
Piston diameter	50 mm, 63 mm, 80 mm	20 mm, 32 mm, 50 mm, 80 mm
Permissible impact force on the advanced piston rod	3,000 ... 6,000 N	170 ... 14,600 N
Stroke	30 ... 40 mm	15 ... 40 mm
Position sensing	Via proximity sensor	Via proximity sensor
Toggle lever position sensing	Via inductive sensor	
Description	<ul style="list-style-type: none"> • Toggle lever design • Integrated adjustable shock absorber for smooth and adapted stopping • Up to 800 kg impact load • For position sensing on the piston • For position sensing on the toggle lever by inductive sensor • Lever locking mechanism • Toggle lever deactivator 	<ul style="list-style-type: none"> • Trunnion and roller version • Absorption of high lateral forces • Direct mounting of solenoid valves on flange plate
→ Page/online	dfst	sta

1

Clamping cylinders

	
Type	Clamping module EV
Clamping area	10x30, 15x40, 15x63, 20x120, 20x180, 20x75, Ø 12, Ø 16, Ø 20, Ø 25, Ø 32, Ø 40, Ø 50, Ø 63
Stroke	3 ... 5 mm
Description	<ul style="list-style-type: none"> • Single-acting, with reset function • Clamping force 55 ... 1,690 N • Compact cylinders without piston rod, with diaphragm • Flat, space-saving design • Hermetically sealed • Pressure plates and foot mounting as accessories
→ Page/online	ev

Linear/swivel clamps

	
Type	Linear/swivel clamp CLR
Piston diameter	12 mm, 16 mm, 20 mm, 25 mm, 32 mm, 40 mm, 50 mm, 63 mm
Theoretical clamping force at 6 bar	51 ... 1,682 N
Clamping stroke	10 ... 50 mm
Swivel angle	90°+/- 2°, 90°+/- 3°, 90°+/- 4°
Description	<ul style="list-style-type: none"> • Double-acting • Swivelling and clamping in one step • Swivel direction adjustable • Compact • Clamping fingers as accessories • Available with dust and welding spatter protection • For position sensing
→ Page/online	clr

Hinge cylinders

	
Type	Hinge cylinder DW, DWA, DWB, DWC
Piston diameter	50 mm, 63 mm, 80 mm
Stroke	10 ... 200 mm
Theoretical force at 6 bar, advancing	1,178 ... 3,016 N
Position sensing	Via proximity sensor, none
Cushioning	PPV: pneumatic cushioning, adjustable at both ends
Description	<ul style="list-style-type: none"> • Hinge cylinder for clamping components during the welding process • Easy assembly thanks to swivel bearing on the bearing cap • Integrated flow control • Integrated end-position cushioning
→ Page/online	dw

Bellows actuators

	
Type	Bellows actuator EB
Size	145, 165, 215, 250, 325, 385
Stroke	60 ... 230 mm
Description	<ul style="list-style-type: none"> • Use as a spring element or for reducing oscillations • Single-bellows or double-bellows actuator • High forces with a short stroke • Uniform movement: no stick-slip effect • Use in dusty environments or in water • Maintenance-free
→ Page/online	eb

Fluidic muscle

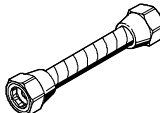
		
Type	Fluidic muscle DMSP	Fluidic muscle MAS
Size	10, 20, 40	10, 20, 40
Theoretical force at 6 bar	480 ... 6,000 N	480 ... 6,000 N
Nominal length	40 ... 9,000 mm	40 ... 9,000 mm
Max. contraction	25% of nominal length	25% of nominal length
Description	<ul style="list-style-type: none"> • With press-fitted connection • Up to 30% less weight: superb force/weight ratio • Single-acting, pulling • Three integrated adapter variants • Ten times the initial force of a comparable pneumatic cylinder • Judder-free movements • Hermetically sealed design offers protection against dust, dirt and moisture 	<ul style="list-style-type: none"> • With screwed connection • Available with force retention • Single-acting, pulling • Use of customised mounting options • Ten times the initial force of a comparable pneumatic cylinder • Judder-free movements • Hermetically sealed design offers protection against dust, dirt and moisture
→ Page/online	dmsp	mas

1

Software tool

<p>Rotary indexing table selection</p>		<p>This tool helps you to select the right rotary indexing table of the type DHTG from Festo for your application. Let yourself be guided by the program – enter the general parameters and you will receive at least one suggestion for the product best suited to your application.</p>
		<p>This tool can be found</p> <ul style="list-style-type: none"> • in the electronic catalogue via the blue icons in the product tree underneath the search field, or • on the website under Support in the Engineering software area, or • on the DVD under Selection and sizing.



Rotary indexing tables

Type	Rotary indexing table DHTG	
Size	65, 90, 140, 220	
Torque at 6 bar	2.1 ... 58.9 Nm	
Indexing stations	2 ... 24	
Description	<ul style="list-style-type: none"> • Sturdy mechanical system • Easy planning and commissioning • Rotary table diameters: 65, 90, 140, 220 mm • Various directions of rotation possible 	
→ Page/online	dhtg	



Pneumatic feed units

Type	Pneumatic feed unit BV	
Size	50 mm, 100 mm, 200 mm	
Working stroke	0 ... 350 mm	
Theoretical force at 6 bar, advancing	240 ... 800 N	
Theoretical force at 6 bar, retracting	180 ... 640 N	
Mounting position	Any	
Description	<ul style="list-style-type: none"> • Compact units for stepped feeding of belts, strips, rods, profiles and tubes • Infinitely adjustable feed force, feed length, clamping and feed force 	
→ Page/online	bv	



Linear actuators for process automation

		
Type	Linear actuator with displacement encoder DFPI	Linear actuator Copac DLP
Piston diameter	100 mm, 125 mm, 160 mm, 200 mm, 250 mm, 320 mm	80 mm, 100 mm, 125 mm, 160 mm, 200 mm, 250 mm, 320 mm
Theoretical force at 6 bar, advancing	4,712 ... 48,255 N	3,016 ... 48,255 N
Stroke	40 ... 990 mm	40 ... 600 mm
Description	<ul style="list-style-type: none"> • Actuation of linear process valves in process engineering systems • With integrated displacement encoder (potentiometer) • Available with integrated positioning controller and valve manifold • Sturdy and compact housing with high degree of protection • Ideal for outdoor use thanks to high corrosion resistance • Suitable for use in water, industrial process water and sewage technology, as well as the silage and bulk goods industry • Easy integration into an existing control architecture 	<ul style="list-style-type: none"> • Approved in accordance with Directive 94/9/EC (ATEX) • Port pattern as per NAMUR for solenoid valves to VDI/VDE 3845 • Mounting hole pattern to ISO 5210 • Piston rod with male thread • For position sensing
→ Page/online	dfpi	dtp

Quarter turn actuators for process automation

			
Type	Quarter turn actuator Sypar DAPS	Quarter turn actuator DFPB	Quarter turn actuator Copar DRD, DRE
Torque at nominal operating pressure and 0° swivel angle	8 ... 8,000 Nm	7 ... 945 Nm	
Torque at 6 bar			53.5 ... 8,814 Nm
Swivel angle	90°	90°	90°
Description	<ul style="list-style-type: none"> • High break-away torques • Approved in accordance with Directive 94/9/EC (ATEX) • Flange hole pattern to ISO 5211 • Mounting hole pattern to VDI/VDE 3845 • Port pattern as per NAMUR for solenoid valves to VDI/VDE 3845 • Available with handwheel as a manual emergency override • Corrosion-resistant variant made from stainless steel 	<ul style="list-style-type: none"> • Identical torque characteristic across the entire rotation angle range of 90° • Process valve connection to ISO 5211 on both sides • Can be mounted on all process valves using pressure relief slot • Mounting hole pattern to VDI/VDE 3845 • Sturdy, non-slip and easy-to-clean aluminium housing • Long service life, low wear • Increased corrosion protection 	<ul style="list-style-type: none"> • For automating swivel valves in the process industry • Sturdy and precise • For highly accurate advancing to various positions • Flange hole pattern to ISO 5211 • Mounting hole pattern to VDI/VDE 3845 • Port pattern as per NAMUR for solenoid valves to VDI/VDE 3845
→ Page/online	daps	dfpb	drd

Accessories for actuators for process automation

		
Type	Measuring unit ASDLP	Positioner CMSX
Description	<ul style="list-style-type: none"> • For linear actuators DLP for mechanical, infinite sensing of movement • For closed-loop and open-loop control of gate slides, flat slide valves and weirs particularly in the area of water and sewage technology and the bulk goods industry • Interface to the positioners to VDI/VDE 3845 (NAMUR) 	<ul style="list-style-type: none"> • For position control of double-acting pneumatic quarter turn actuators in process automation systems • Simple and efficient position control based on the PID control algorithm • Suitable for operation with quarter turn actuators with a swivel angle of approx. 90° and a mechanical interface in accordance with VDI/VDE Directive 3845
→ Page/online	asdlp	cmsx

1





Cylinder/valve combinations

Type	 Standard cylinder DNC-V
Mode of operation	Double-acting
Piston diameter	32 mm, 40 mm, 50 mm, 63 mm, 80 mm, 100 mm
Theoretical force at 6 bar, advancing	415 ... 4,712 N
Stroke	100... 2,000 mm
Cushioning	P: elastic cushioning rings/pads at both ends, PPV: pneumatic cushioning, adjustable at both ends
Description	<ul style="list-style-type: none"> • Standard hole pattern • Assembled and fitted with tubing ready for connection • Particularly suitable for decentralised use in larger systems • Valve variants: single or double solenoid valves, assembled on the right or left • For position sensing • Wide range of variants
→ Page/online	dnc-v





Software tool

Shock absorber selection		Whether diagonal or vertical, curved or straight, lever or disc, all types of cushioned movements are taken into account. The software tool always recommends the best shock absorber.	This tool can be found <ul style="list-style-type: none"> • in the electronic catalogue via the blue icons in the product tree underneath the search field, or • on the website under Support in the Engineering software area, or • on the DVD under Selection and sizing.
---------------------------------	--	--	--

Shock absorbers

Type	 Shock absorber DYSR	 Shock absorber YSR-C	 Shock absorber YSRW	 Shock absorber YSRWJ
Stroke	8 ... 60 mm	4 ... 60 mm	8 ... 34 mm	8 ... 14 mm
Max. energy absorption per stroke	4 ... 384 J	0.6 ... 380 J	1.3 ... 70 J	1 ... 3 J
Cushioning	Adjustable	Self-adjusting	Self-adjusting, soft characteristic curve	Self-adjusting, soft characteristic curve
Description	<ul style="list-style-type: none"> • Hydraulic shock absorber with spring return • Adjustable cushioning hardness 	<ul style="list-style-type: none"> • Hydraulic shock absorber with path-controlled flow control function • Rapidly increasing cushioning force curve • Short cushioning stroke • Suitable for rotary drives 	<ul style="list-style-type: none"> • Hydraulic shock absorber with path-controlled flow control function • Gently increasing cushioning force curve • Long cushioning stroke • Suitable for low-vibration operation • Short cycle times possible 	<ul style="list-style-type: none"> • Cushioning with self-adjusting, progressive hydraulic shock absorber • Gently increasing cushioning force curve • Adjustable cushioning stroke • End-position sensing with proximity sensor SME/SMT-8 • Precision end-precision adjustment
→ Page/online	dysr	ysr-c	ysrw	ysrwj

Shock absorbers

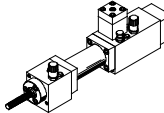

				
Type	Shock absorber DYEY-Y1, DYEY-Y1F	Shock absorber DYSC	Shock absorber DYSW	Hydraulic cushioning cylinder DYHR
Stroke	0.9 ... 7 mm	4 ... 18 mm	6 ... 20 mm	20 ... 60 mm
Max. energy absorption per stroke	0.005 ... 1.2 J	0.6 ... 25 J	0.8 ... 12 J	32 ... 384 J
Cushioning	P cushioning with metal fixed stop, P cushioning without metal fixed stop	Self-adjusting	Self-adjusting, soft characteristic curve	Adjustable
Description	<ul style="list-style-type: none"> • Mechanical shock absorber with flexible rubber buffer • Flexible rubber buffer allows a defined metal end position • Adjustable cushioning hardness • Ideal for cushioning low energy • With precise metal end position 	<ul style="list-style-type: none"> • Hydraulic shock absorber with path-controlled flow control function • Rapidly increasing cushioning force curve • Short cushioning stroke • Suitable for rotary drives • With metal fixed stop 	<ul style="list-style-type: none"> • Hydraulic shock absorber with path-controlled flow control function • Gently increasing cushioning force curve • Long cushioning stroke • Suitable for low-vibration operation • Short cycle times possible • With metal fixed stop 	<ul style="list-style-type: none"> • Hydraulic cushioning cylinder for constant, slow braking speeds across the entire stroke • Braking speed can be precisely adjusted • A built-in compression spring returns the piston rod to the initial position • Suitable for slow feed speeds in the range up to 0.1 m/s
→ Page/online	dyef	dysc	dysw	dyhr

Shock absorbers

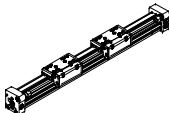
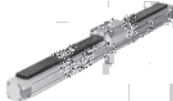

		
Type	Hydraulic cushioning cylinder YD	Hydraulic cushioning cylinder YZL
Stroke	70 ... 250 mm	80 ... 250 mm
Max. energy absorption per stroke	80 N with flow control valve open ... 4,000 N	220 N retracting, 150 N advancing ... 4,000 N
Cushioning	Adjustable	Adjustable
Description	<ul style="list-style-type: none"> • With speed regulation in one direction (piston rod retracting) and rapid traverse (piston rod advancing) • Infinitely adjustable, slow constant speed 	<ul style="list-style-type: none"> • With speed regulation in both directions and pneumatic actuator for intermediate rapid traverse during advance and return • Infinitely adjustable, slow constant speed
→ Page/online	yd	yzl

1

Accessories for pneumatic drives

Type	 Guide unit FEN, FENG	 Passive guide axis DGC-FA	 Passive guide axis FDG	 Clamping cartridge KP
Size	8, 12, 20, 25, 32, 40, 50, 63, 80, 100	8, 12, 18, 25, 32, 40, 50, 63	18, 25, 32, 40, 50, 63	
Stroke	1 ... 500 mm	1 ... 8,500 mm	1 ... 5,100 mm	
Round material to be clamped				4 ... 32 mm
Static holding force				80 ... 7,500 N
Description	<ul style="list-style-type: none"> For protecting standard cylinders against rotation at high torque loads High guide precision for workpiece handling Plain or recirculating ball bearing guide 	<ul style="list-style-type: none"> Without drive With protected recirculating ball bearing guide With guide and freely movable slide Various cushioning options For supporting force and torque capacity in multi-axis applications Increased torsional resistance Reduced vibrations with dynamic loads Available with additional slide 	<ul style="list-style-type: none"> Without drive With recirculating ball bearing guide With guide and freely movable slide For supporting force and torque capacity in multi-axis applications Increased torsional resistance Reduced vibrations with dynamic loads 	<ul style="list-style-type: none"> For in-house assembly of clamping units Not certified for use in safety-relevant control systems
→ Page/online	fen	dgc-fa	fdg	kp

Accessories for pneumatic drives

Type	 Clamping unit KPE, KEC, KEC-S	 Mounting components	 Piston rod attachments
Size			
Stroke			
Round material to be clamped	4 ... 32 mm		
Static holding force	80 ... 8,000 N		
Description	<ul style="list-style-type: none"> KPE: ready-to-install combination of clamping cartridge KP and housing KEC: for use as a holding device (static application) KEC-S: for safety-related applications 	<ul style="list-style-type: none"> Clevis feet LNG Trunnion supports LNZ Slot nuts NST/NSTL Centring pins/sleeves NSTH 	<ul style="list-style-type: none"> Rod eyes SGS Rod clevises SG, CRSG Self-aligning rod couplers FK Adapters AD Coupling pieces KSG
→ Page/online	kpe	n_015001	n__03150

Customised components – for your specific requirements



Drives with customised designs

Can't find the pneumatic drive you need in our catalogue? We can offer you customised components that are tailored to your specific requirements – from minor product modifications to complete new product developments.

Common product modifications:

- Materials for special ambient conditions
- Customised dimensions
- Special strokes
- Customised mounting options
- Implementation of special cylinder functions (cylinder/valve combinations, single-acting principle, etc.)

Many additional variants are possible. Ask your Festo sales engineer, who will be happy to help. Further information on customised components can be found on your local website at www.festo.com.



- Strokes of up to 2,800 mm
- PPS cushioning with ample cushioning capacity
- Wide range of variants for customised applications
- Comprehensive range of mounting accessories for just about every type of installation
- Spare parts service
- ★ Quick ordering of basic designs → 38

→ www.festo.com/catalogue/dsbc

Product range overview

Type/function	Piston Ø [mm]	Stroke [mm]	Force [N]	Product options											
				Q	T	F	P	PPS	PPV	A	N3	T1	T4	A3	...E
DSBC															
Double-acting	32, 40, 50, 63, 80, 100, 125	1 ... 2,800	483 ... 7,363	■	■	■	■	■	■	■	■	■	■	■	■

Product options

Q	With protection against rotation	D3	Sensor slot on 3 sides	R3	High corrosion protection	A3	Suitable for unlubricated operation
L	Low friction	P	Elastic cushioning rings/pads at both ends	T1	Heat-resistant seals up to max. 120 °C	E	Piston rod extension
U	Uniformly slow movement	PPS	Pneumatic cushioning, self-adjusting at both ends	T3	Low temperature	L	Piston rod thread extension
C	Clamping unit attached	PPV	Pneumatic cushioning, adjustable at both ends	T4	Heat-resistant seals up to max. 150 °C		
T	Through piston rod	A	Position sensing	P2	Bellows on bearing cap		
F	Female piston rod thread	N3	Standard conforms to ISO 15552	A2	Hard scraper		

Standard cylinders DSBC, to ISO 15552

1 Technical data

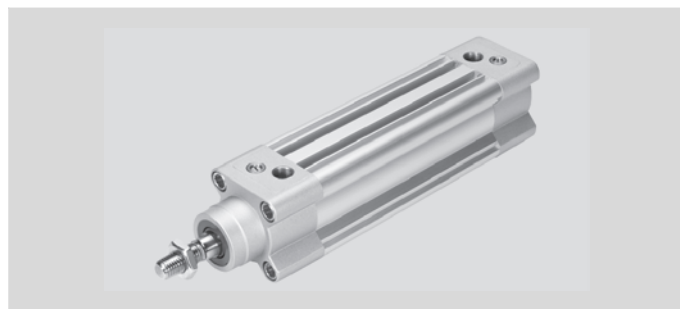
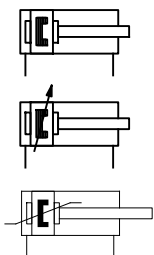

Technical data		Dimensions → 44						
Piston Ø		32	40	50	63	80	100	125
Pneumatic connection		G $\frac{1}{8}$	G $\frac{1}{4}$	G $\frac{1}{4}$	G $\frac{3}{8}$	G $\frac{3}{8}$	G $\frac{1}{2}$	G $\frac{1}{2}$
Piston rod thread		M10x1.25	M12x1.25	M16x1.5	M16x1.5	M20x1.5	M20x1.5	M27x2
Cushioning	P	Elastic cushioning rings/pads at both ends						
	PPV	Pneumatic cushioning, adjustable at both ends						
	PPS	Pneumatic cushioning, self-adjusting at both ends						
Cushioning length	[mm]	20	20	22	22	32	32	46
Theoretical force at 6 bar, advancing	[N]	483	754	1,178	1,870	3,016	4,712	7,363
Theoretical force at 6 bar, retracting	[N]	415	633	990	1,682	2,721	4,418	6,881
Max. impact energy in the end positions	[J]	0.4	0.7	1.0	1.3	1.8	2.5	3.3
	T1 [J]	0.2	0.35	0.5	0.65	0.9	1.25	1.65

Operating conditions		Dimensions → 44						
Piston Ø		32	40	50	63	80	100	125
Operating pressure	[bar]	0.6 ... 12			0.4 ... 12			0.2 ... 10
	A3 [bar]	1.5 ... 12			1 ... 12	0.6 ... 12		0.6 ... 10
Ambient temperature ¹⁾	[°C]	-20 ... +80						
	T1 [°C]	0 ... +120						
	T4 [°C]	0 ... +150						

1) Note operating range of proximity sensors.

Materials	
Piston rod	High-alloy stainless steel
Bearing cap	Coated die-cast aluminium
Cylinder barrel	Smooth anodised wrought aluminium alloy
End cap	Coated die-cast aluminium
Seals	TPE-U (PU)

Ordering – Product options

Configurable product

This product and all its options can be ordered using the configurator.

The configurator can be found under Products on the DVD or
[→ www.festo.com/catalogue/...](http://www.festo.com/catalogue/...)

Enter the type code in the search field.

Standard cylinders DSBC, to ISO 15552

★ Quick ordering

1

PPS – Pneumatic cushioning, self-adjusting at both ends

Part No.	Type
Piston Ø 32 mm	
2123085	DSBC-32-20-PPSA-N3
1376467	DSBC-32-25-PPSA-N3
2123086	DSBC-32-30-PPSA-N3
1376468	DSBC-32-40-PPSA-N3
1376469	DSBC-32-50-PPSA-N3
2123087	DSBC-32-60-PPSA-N3
2123088	DSBC-32-70-PPSA-N3
1376470	DSBC-32-80-PPSA-N3
1376471	DSBC-32-100-PPSA-N3
1376472	DSBC-32-125-PPSA-N3
2123089	DSBC-32-150-PPSA-N3
1376473	DSBC-32-160-PPSA-N3
1376474	DSBC-32-200-PPSA-N3
1376475	DSBC-32-250-PPSA-N3
2123090	DSBC-32-300-PPSA-N3
1376476	DSBC-32-320-PPSA-N3
1376477	DSBC-32-400-PPSA-N3
1376478	DSBC-32-500-PPSA-N3
Piston Ø 40 mm	
2123780	DSBC-40-20-PPSA-N3
1376903	DSBC-40-25-PPSA-N3
2123781	DSBC-40-30-PPSA-N3
1376904	DSBC-40-40-PPSA-N3
1376905	DSBC-40-50-PPSA-N3
2123782	DSBC-40-60-PPSA-N3
2123783	DSBC-40-70-PPSA-N3
1376906	DSBC-40-80-PPSA-N3
1376907	DSBC-40-100-PPSA-N3
1376908	DSBC-40-125-PPSA-N3
2123784	DSBC-40-150-PPSA-N3
1376909	DSBC-40-160-PPSA-N3
1376910	DSBC-40-200-PPSA-N3
1376911	DSBC-40-250-PPSA-N3
2123785	DSBC-40-300-PPSA-N3
1376912	DSBC-40-320-PPSA-N3
1376913	DSBC-40-400-PPSA-N3
1376914	DSBC-40-500-PPSA-N3

Part No.	Type
Piston Ø 50 mm	
2102628	DSBC-50-20-PPSA-N3
1376301	DSBC-50-25-PPSA-N3
2102629	DSBC-50-30-PPSA-N3
1376304	DSBC-50-40-PPSA-N3
1376305	DSBC-50-50-PPSA-N3
2102630	DSBC-50-60-PPSA-N3
2102631	DSBC-50-70-PPSA-N3
1376306	DSBC-50-80-PPSA-N3
1376307	DSBC-50-100-PPSA-N3
1376308	DSBC-50-125-PPSA-N3
2102632	DSBC-50-150-PPSA-N3
1376309	DSBC-50-160-PPSA-N3
1376310	DSBC-50-200-PPSA-N3
1376311	DSBC-50-250-PPSA-N3
2102633	DSBC-50-300-PPSA-N3
1376312	DSBC-50-320-PPSA-N3
1376313	DSBC-50-400-PPSA-N3
1376314	DSBC-50-500-PPSA-N3

Part No.	Type
Piston Ø 63 mm	
2126684	DSBC-63-20-PPSA-N3
1383632	DSBC-63-25-PPSA-N3
2126685	DSBC-63-30-PPSA-N3
1383633	DSBC-63-40-PPSA-N3
1383634	DSBC-63-50-PPSA-N3
2126686	DSBC-63-60-PPSA-N3
2126687	DSBC-63-70-PPSA-N3
1383635	DSBC-63-80-PPSA-N3
1383636	DSBC-63-100-PPSA-N3
1383637	DSBC-63-125-PPSA-N3
2126688	DSBC-63-150-PPSA-N3
1383638	DSBC-63-160-PPSA-N3
1383639	DSBC-63-200-PPSA-N3
1383640	DSBC-63-250-PPSA-N3
2126689	DSBC-63-300-PPSA-N3
1383641	DSBC-63-320-PPSA-N3
1383642	DSBC-63-400-PPSA-N3
1383643	DSBC-63-500-PPSA-N3

★ Quick ordering

PPV – Pneumatic cushioning, adjustable at both ends

Part No.	Type
Piston Ø 32 mm	
2123069	DSBC-32-20-PPVA-N3
1376422	DSBC-32-25-PPVA-N3
2123070	DSBC-32-30-PPVA-N3
1376423	DSBC-32-40-PPVA-N3
1376424	DSBC-32-50-PPVA-N3
2123071	DSBC-32-60-PPVA-N3
2123072	DSBC-32-70-PPVA-N3
1376425	DSBC-32-80-PPVA-N3
1376426	DSBC-32-100-PPVA-N3
1376427	DSBC-32-125-PPVA-N3
2123073	DSBC-32-150-PPVA-N3
1376428	DSBC-32-160-PPVA-N3
1376429	DSBC-32-200-PPVA-N3
1376430	DSBC-32-250-PPVA-N3
2123074	DSBC-32-300-PPVA-N3
1376431	DSBC-32-320-PPVA-N3
1376432	DSBC-32-400-PPVA-N3
1376433	DSBC-32-500-PPVA-N3
Piston Ø 40 mm	
2123166	DSBC-40-20-PPVA-N3
1376656	DSBC-40-25-PPVA-N3
2123167	DSBC-40-30-PPVA-N3
1376657	DSBC-40-40-PPVA-N3
1376658	DSBC-40-50-PPVA-N3
2123224	DSBC-40-60-PPVA-N3
2123225	DSBC-40-70-PPVA-N3
1376659	DSBC-40-80-PPVA-N3
1376660	DSBC-40-100-PPVA-N3
1376661	DSBC-40-125-PPVA-N3
2123226	DSBC-40-150-PPVA-N3
1376662	DSBC-40-160-PPVA-N3
1376663	DSBC-40-200-PPVA-N3
1376664	DSBC-40-250-PPVA-N3
2123227	DSBC-40-300-PPVA-N3
1376665	DSBC-40-320-PPVA-N3
1376666	DSBC-40-400-PPVA-N3
1376667	DSBC-40-500-PPVA-N3

Part No.	Type
Piston Ø 50 mm	
2098969	DSBC-50-20-PPVA-N3
1366948	DSBC-50-25-PPVA-N3
2098970	DSBC-50-30-PPVA-N3
1366949	DSBC-50-40-PPVA-N3
1366950	DSBC-50-50-PPVA-N3
2098972	DSBC-50-60-PPVA-N3
2098973	DSBC-50-70-PPVA-N3
1366951	DSBC-50-80-PPVA-N3
1366952	DSBC-50-100-PPVA-N3
1366953	DSBC-50-125-PPVA-N3
2098974	DSBC-50-150-PPVA-N3
1366954	DSBC-50-160-PPVA-N3
1366955	DSBC-50-200-PPVA-N3
1366956	DSBC-50-250-PPVA-N3
2098975	DSBC-50-300-PPVA-N3
1366957	DSBC-50-320-PPVA-N3
1366958	DSBC-50-400-PPVA-N3
1366959	DSBC-50-500-PPVA-N3

Part No.	Type
Piston Ø 63 mm	
2125490	DSBC-63-20-PPVA-N3
1383578	DSBC-63-25-PPVA-N3
2125491	DSBC-63-30-PPVA-N3
1383579	DSBC-63-40-PPVA-N3
1383580	DSBC-63-50-PPVA-N3
2125492	DSBC-63-60-PPVA-N3
2125493	DSBC-63-70-PPVA-N3
1383581	DSBC-63-80-PPVA-N3
1383582	DSBC-63-100-PPVA-N3
1383583	DSBC-63-125-PPVA-N3
2125494	DSBC-63-150-PPVA-N3
1383584	DSBC-63-160-PPVA-N3
1383585	DSBC-63-200-PPVA-N3
1383586	DSBC-63-250-PPVA-N3
2125495	DSBC-63-300-PPVA-N3
1383587	DSBC-63-320-PPVA-N3
1383588	DSBC-63-400-PPVA-N3
1383589	DSBC-63-500-PPVA-N3

Standard cylinders DSBC, to ISO 15552

Accessories

1

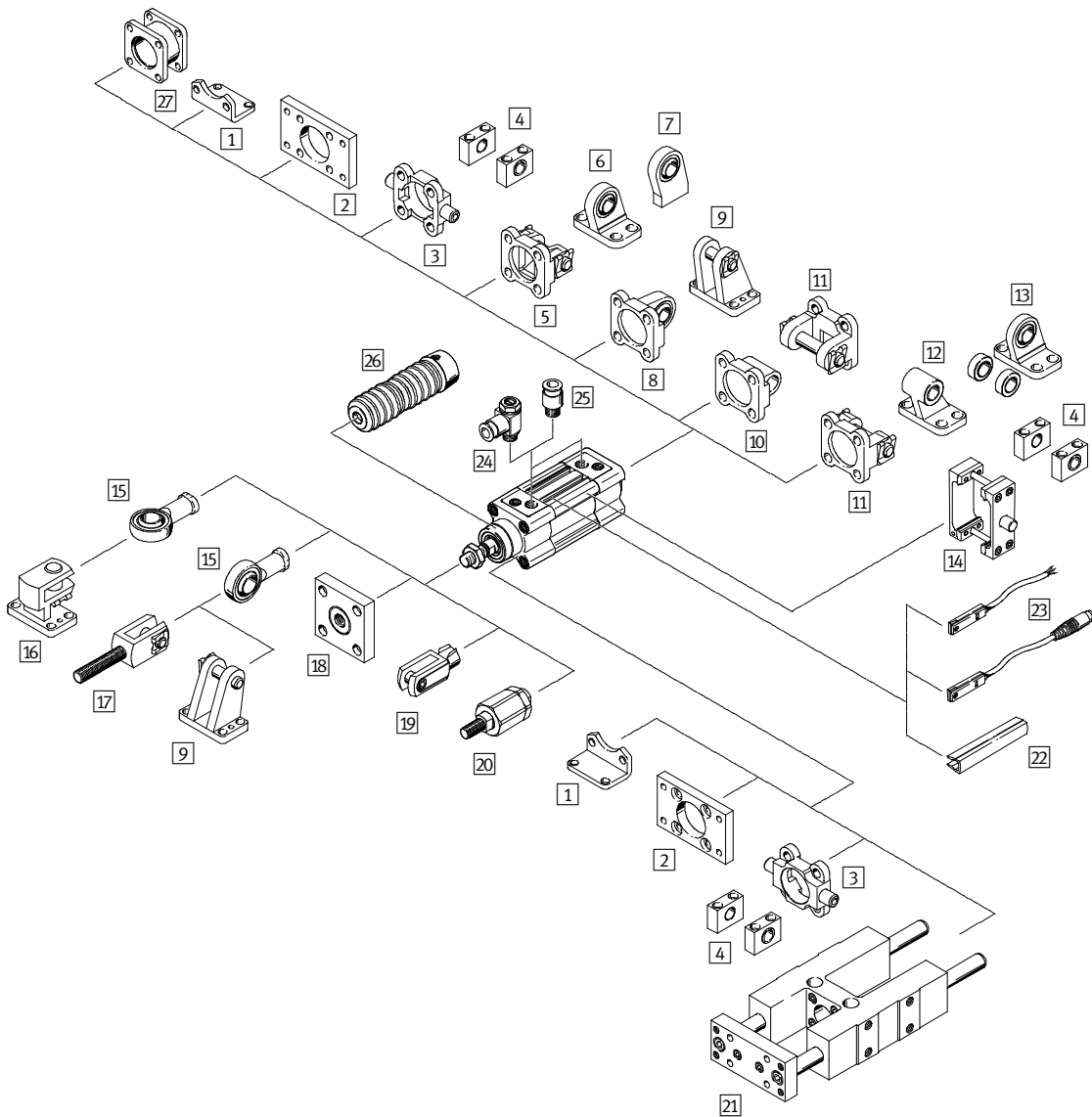

		→ Page/online
1	Foot mounting HNC Foot mounting CRHNC	41 dsbc
2	Flange mounting FNC Flange mounting CRFNG	41 dsbc
3	Trunnion flange ZNCF Trunnion flange CRZNG	41 dsbc
4	Trunnion support LNZG Trunnion support CRLNZG	41 dsbc
5	Swivel flange SNC	41
6	Clevis foot LSNG	41
7	Clevis foot LSNSG	41
8	Swivel flange SNCS	41
9	Clevis foot LBG	41
10	Swivel flange SNCL	41
11	Swivel flange SNCB	41
12	Clevis foot LNG	41
13	Clevis foot LSN	41

		→ Page/online
14	Trunnion mounting kit DAMT	42
15	Rod eye SGS/CRSGS	42
16	Right-angle clevis foot LQG	42
17	Rod clevis SGA	42
18	Coupling piece KSG	42
18	Coupling piece KSZ	42
19	Rod clevis SG Rod clevis CRSG	42 dsbc
20	Self-aligning rod coupler FK	42
21	Guide unit FENG	42
22	Slot cover ABP-5-S	42
23	Proximity sensor SME/SMT-8M and connecting cable NEBU	43
24	One-way flow control valve GRLA	43
25	Push-in fitting QS	908
26	Protective bellows kit DADB	dsbc
27	Multi-position kit DPNC	43

Accessories – Ordering data

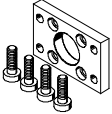
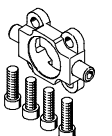
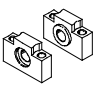
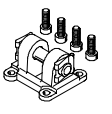
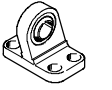
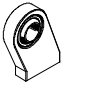

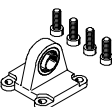
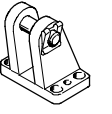
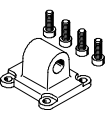
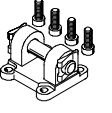
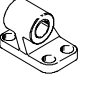
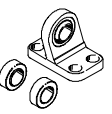



	For Ø		Part No.	Type
1	Foot mounting		Dimensions online: → ddbc	
	32	★	174369	HNC-32
	40	★	174370	HNC-40
	50		174371	HNC-50
	63	★	174372	HNC-63
	80		174373	HNC-80
	100		174374	HNC-100
	125		174375	HNC-125
2	Flange mounting		Dimensions online: → ddbc	
	32	★	174376	FNC-32
	40	★	174377	FNC-40
	50		174378	FNC-50
	63	★	174379	FNC-63
	80		174380	FNC-80
	100		174381	FNC-100
	125		174382	FNC-125
3	Trunnion flange		Dimensions online: → ddbc	
	32		174411	ZNCF-32
	40		174412	ZNCF-40
	50		174413	ZNCF-50
	63		174414	ZNCF-63
	80		174415	ZNCF-80
	100		174416	ZNCF-100
	125		174417	ZNCF-125
4	Trunnion support		Dimensions online: → ddbc	
	32		32959	LNZG-32
	40, 50		32960	LNZG-40/50
	63, 80		32961	LNZG-63/80
	100, 125		32962	LNZG-100/125
5	Swivel flange		Dimensions online: → ddbc	
	32	★	174383	SNC-32
	40	★	174384	SNC-40
	50	★	174385	SNC-50
	63	★	174386	SNC-63
	80		174387	SNC-80
	100		174388	SNC-100
	125		174389	SNC-125
6	Clevis foot		Technical data online: → lsng	
	32		31740	LSNG-32
	40		31741	LSNG-40
	50		31742	LSNG-50
	63		31743	LSNG-63
	80		31744	LSNG-80
	100		31745	LSNG-100
	125		31746	LSNG-125
7	Clevis foot		Technical data online: → lsng	
	32		31747	LSNSG-32
	40		31748	LSNSG-40
	50		31749	LSNSG-50
	63		31750	LSNSG-63
	80		31751	LSNSG-80
	100		31752	LSNSG-100
	125		31753	LSNSG-125

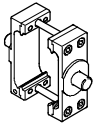

	For Ø		Part No.	Type
8	Swivel flange		Dimensions online: → ddbc	
	32	★	174397	SNCS-32
	40	★	174398	SNCS-40
	50	★	174399	SNCS-50
	63	★	174400	SNCS-63
	80		174401	SNCS-80
	100		174402	SNCS-100
	125		174403	SNCS-125
9	Clevis foot		Technical data online: → lbg	
	32		31761	LBG-32
	40		31762	LBG-40
	50		31763	LBG-50
	63		31764	LBG-63
	80		31765	LBG-80
	100		31766	LBG-100
	125		31767	LBG-125
10	Swivel flange		Dimensions online: → ddbc	
	32	★	174404	SNCL-32
	40	★	174405	SNCL-40
	50		174406	SNCL-50
	63	★	174407	SNCL-63
	80		174408	SNCL-80
	100		174409	SNCL-100
	125		174410	SNCL-125
11	Swivel flange		Dimensions online: → ddbc	
	32	★	174390	SNCB-32
	40	★	174391	SNCB-40
	50	★	174392	SNCB-50
	63	★	174393	SNCB-63
	80		174394	SNCB-80
	100		174395	SNCB-100
	125		174396	SNCB-125
12	Clevis foot		Technical data online: → lng	
	32	★	33890	LNG-32
	40	★	33891	LNG-40
	50	★	33892	LNG-50
	63	★	33893	LNG-63
	80		33894	LNG-80
	100		33895	LNG-100
	125		33896	LNG-125
13	Clevis foot		Technical data online: → lsn	
	32		5561	LSN-32
	40		5562	LSN-40
	50		5563	LSN-50
	63		5564	LSN-63
	80		5565	LSN-80
	100		5566	LSN-100
	125		6987	LSN-125

Standard cylinders DSBC, to ISO 15552

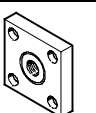
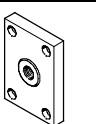
Accessories – Ordering data



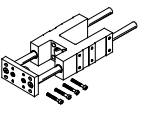
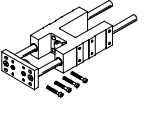



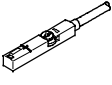
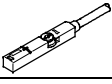
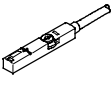

1

	For Ø	Part No.	Type
14 Trunnion mounting kit Dimensions online: → dsbc			
	32	2213233	DAMT-V1-32-A
	40	2214899	DAMT-V1-40-A
	50	2214909	DAMT-V1-50-A
	63	2214971	DAMT-V1-63-A
	80	163529	DAMT-V1-80-A
	100	163530	DAMT-V1-100-A
	125	1812524	DAMT-V8-125-A
15 Rod eye Technical data online: → sgs			
	32	★ 9261	SGS-M10x1,25
	40	★ 9262	SGS-M12x1,25
	50, 63	★ 9263	SGS-M16x1,5
	80, 100	9264	SGS-M20x1,5
	125	10774	SGS-M27x2
16 Right-angle clevis foot Technical data online: → lqg			
	32	31768	LQG-32
	40	31769	LQG-40
	50	31770	LQG-50
	63	31771	LQG-63
	80	31772	LQG-80
	100	31773	LQG-100
	125	31774	LQG-125
17 Rod clevis Technical data online: → sga			
	32	32954	SGA-M10x1,25
	40	10767	SGA-M12x1,25
	50, 63	10768	SGA-M16x1,5
	80, 100	10769	SGA-M20x1,5
	125	10770	SGA-M27x2
18 Coupling piece Technical data online: → ksg			
	32	32963	KSG-M10x1,25
	40	32964	KSG-M12x1,25
	50, 63	32965	KSG-M16x1,5
	80, 100	32966	KSG-M20x1,5
	125	32967	KSG-M20x1,5
18 Coupling piece Technical data online: → ksz			
	32	36125	KSZ-M10x1,25
	40	36126	KSZ-M12x1,25
	50, 63	36127	KSZ-M16x1,5
	80, 100	36128	KSZ-M20x1,5
19 Rod clevis Technical data online: → sg			
	32	★ 6144	SG-M10x1,25
	40	★ 6145	SG-M12x1,25
	50, 63	★ 6146	SG-M16x1,5
	80, 100	6147	SG-M20x1,5
	125	14987	SG-M27x2-B
20 Self-aligning rod coupler Technical data online: → fk			
	32	★ 6140	FK-M10x1,25
	40	★ 6141	FK-M12x1,25
	50, 63	★ 6142	FK-M16x1,5
	80, 100	6143	FK-M20x1,5
	125	10485	FK-M27x2

	For Ø	Part No.	Type
21 Guide unit for variable strokes from 10 ... 500 mm, with recirculating ball bearing guide Technical data online: → feng			
	32	34487	FENG-32-...-KF ¹⁾
	40	34488	FENG-40-...-KF ¹⁾
	50	34489	FENG-50-...-KF ¹⁾
	63	34490	FENG-63-...-KF ¹⁾
	80	34491	FENG-80-...-KF ¹⁾
	100	34492	FENG-100-...-KF ¹⁾
	21 Guide unit for variable strokes from 10 ... 500 mm, with plain-bearing guide Technical data online: → feng		
	32	34481	FENG-32-... ¹⁾
	40	34482	FENG-40-... ¹⁾
	50	34483	FENG-50-... ¹⁾
	63	34484	FENG-63-... ¹⁾
	80	34485	FENG-80-... ¹⁾
	100	34486	FENG-100-... ¹⁾
22 Slot cover²⁾			
		151680	ABP-5-S

- 1) Enter required stroke. Order example: the order code for an appropriate guide unit for the standard cylinder DSBC-40-250 is FENG-40-250-KF (guide unit FENG - piston diameter 40 mm - stroke 250 mm - with recirculating ball bearing guide).
- 2) Packaging unit 2x 0.5 m.

Accessories – Ordering data

	For Ø		Part No.	Type	
23 Proximity sensor for T-slot, magneto-resistive – N/O contact Technical data → 737					
	PNP, cable	★	574335	SMT-8M-A-PS-24V-E-2,5-OE	
	PNP, plug	★	574334	SMT-8M-A-PS-24V-E-0,3-M8D	
	PNP, plug	★	574337	SMT-8M-A-PS-24V-E-0,3-M12	
	NPN, cable	★	574338	SMT-8M-A-NS-24V-E-2,5-OE	
	NPN, plug	★	574339	SMT-8M-A-NS-24V-E-0,3-M8D	
Magneto-resistive – N/C contact Technical data → 737					
	PNP, cable	★	574340	SMT-8M-A-PO-24V-E-7,5-OE	
23 Proximity sensor for T-slot, magnetic reed – N/O contact Technical data → 732					
	Cable	★	543862	SME-8M-DS-24V-K-2,5-OE	
	Cable	★	543863	SME-8M-DS-24V-K-5,0-OE	
	Cable	★	543872	SME-8M-ZS-24V-K-2,5-OE	
	Plug	★	543861	SME-8M-DS-24V-K-0,3-M8D	
Technical data → 734					
	Cable	★	150855	SME-8-K-LED-24	
	Plug		150857	SME-8-S-LED-24	
Magnetic reed – N/C contact Technical data → 734					
	Cable		160251	SME-8-O-K-LED-24	
23 Connecting cable, straight socket Technical data → 949					
	2.5 m	★	541333	NEBU-M8G3-K-2.5-LE3	
	5 m	★	541334	NEBU-M8G3-K-5-LE3	
	2.5 m		541363	NEBU-M12G5-K-2.5-LE3	
	5 m		541364	NEBU-M12G5-K-5-LE3	
Angled socket Technical data → 949					
	2.5 m	★	541338	NEBU-M8W3-K-2.5-LE3	
	5 m	★	541341	NEBU-M8W3-K-5-LE3	
	2.5 m		541367	NEBU-M12W5-K-2.5-LE3	
	5 m		541370	NEBU-M12W5-K-5-LE3	
27 Multi-position kit Technical data online: → dsbc					
	32		174418	DPNC-32	
	40		174419	DPNC-40	
	50		174420	DPNC-50	
	63		174421	DPNC-63	
	80		174422	DPNC-80	
	100		174423	DPNC-100	

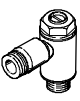
Function	For Ø	Connection		Part No.	Type	
		Thread	O.D.			
24 One-way flow control valve for exhaust air flow control¹⁾ with slotted head screw, metal Technical data → 609						
	32	G $\frac{1}{8}$	4	★	193143	GRLA- $\frac{1}{8}$ -QS-4-D
	40, 50		6	★	193144	GRLA- $\frac{1}{8}$ -QS-6-D
	63, 80	G $\frac{3}{8}$	8	★	193150	GRLA- $\frac{3}{8}$ -QS-8-D
	100, 125	G $\frac{1}{2}$	12	★	193152	GRLA- $\frac{1}{2}$ -QS-12-D

1) The recommended flow control valves are based on a tubing length to the valve of 1 m. For deviations of ±50%, flow control valves with a bigger or smaller flow rate must be selected to guarantee the optimum flow control function and cylinder speed.

Standard cylinders DSBC, to ISO 15552

Dimensions

1 Basic design and A3 – Unlubricated operation

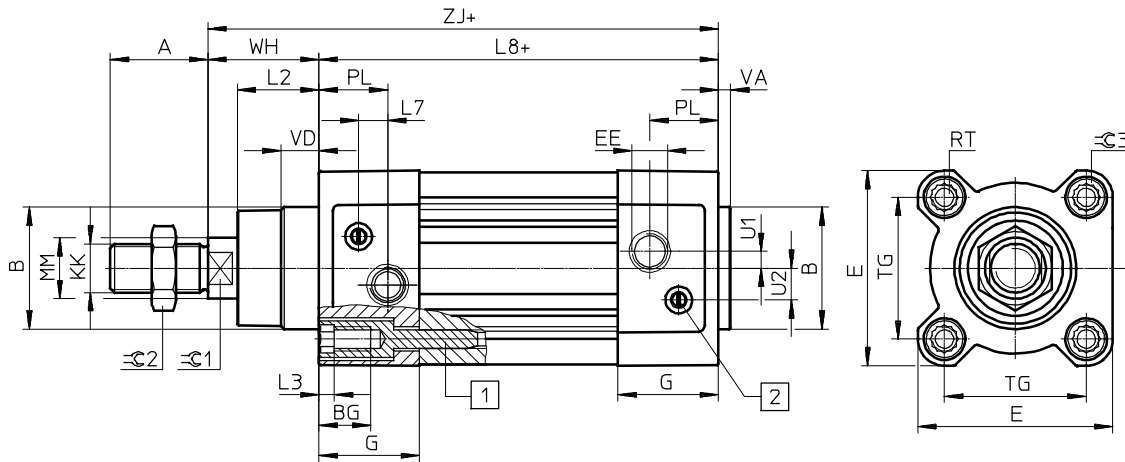

∅ 125

∅ 80/100

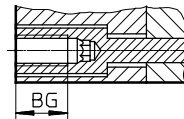
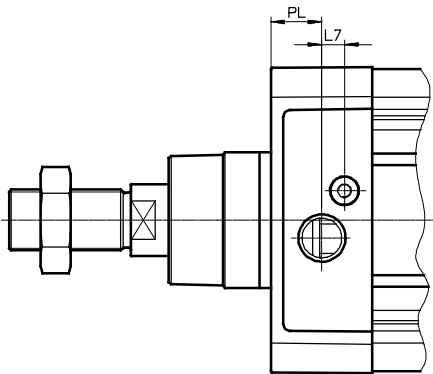

- 1 Socket head screw with female thread for mounting attachments
- 2 Regulating screw for adjustable end-position cushioning

∅	A	B	BG	E	EE	G	U2	U1	KK	L2	L3	L7	L8
[mm]	-0.5	∅ d11	min.	+0.5		-0.2	±0.1	±0.1		-0.2	max.		±0.4
32	22	30	16	45	G ³ / ₈	28	5.7	5.25	M10x1.25	18	5	6.5	94
40	24	35	16	54	G ¹ / ₄	33	8	4	M12x1.25	21.3	5	7.5	105
50	32	40	17	64	G ¹ / ₄	33	10.4	5.5	M16x1.5	26.8	5	9.5	106
63	32	45	17	75	G ³ / ₈	40.5	12.75	6.25	M16x1.5	27	5	9	121
80	40	45	17	93	G ³ / ₈	43	12.5	8	M20x1.5	34.2	-	11	128
100	40	55	17	110	G ¹ / ₂	48	13.5	10	M20x1.5	38	-	7.5	138
125	54	60	20	136	G ¹ / ₂	44.7	13	8	M27x2	45.5	-	10	160

∅	MM ∅	PL	RT	TG	VA	VD	WH	ZJ	∅C1	∅C2	∅C3
[mm]		±0.1		±0.3	-0.2	+0.5	+2.2	+1.8			
32	12	19.5	M6	32.5	4	10	26	119.1	10	16	6
40	16	22.5	M6	38	4	10.5	28.7	133.9	13	18	6
50	20	22.5	M8	46.5	4	11.5	35.6	141.8	17	24	8
63	20	27.5	M8	56.5	4	15	35.9	157.1	17	24	8
80	25	30	M10	72	4	15.7	45.4	173.6	22	30	6
100	25	31.5	M10	89	4	19.2	49.3	187.5	22	30	6
125	32	22.5	M12	110	6	20.5	65	225	27	41	8

Dimensions

Variant

T – Through piston rod

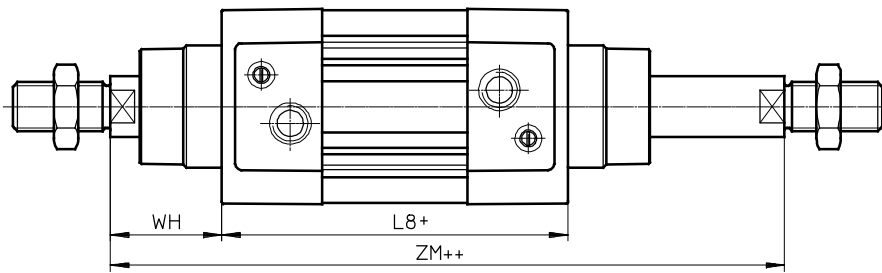

+ = plus stroke length
++ = plus 2x stroke length

Q – With protection against rotation

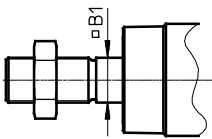

Note
Protection against rotation at one end in combination with the variant T.

F – Female thread

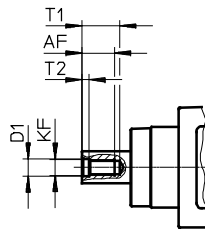

Note
Female thread at both ends in combination with the variant T.

...E – Piston rod extension

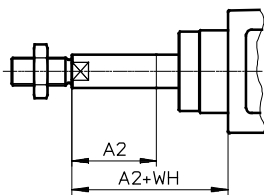

Note
Piston rod extension only at the square piston rod in combination with the variant T and Q.

+ = plus stroke length

∅ [mm]	A	A1		A2		AF min.
		min.	max.	min.	max.	
32	22	1	35	1	500	12
40	24	1	35	1	500	12
50	32	1	70	1	500	16
63	32	1	70	1	500	16
80	40	1	70	1	500	20
100	40	1	70	1	500	20
125	54	1	70	1	500	32

∅ [mm]	B1	D1	KF	L8 ±0.4	T1 max.	T2	WH +2.2	ZM +1
32	10	6.4	M6	94	16	2.6	26	146.1
40	12	8.4	M8	105	16	3.3	28.7	164.8
50	16	10.5	M10	106	21	4.7	35.6	179.8
63	16	10.5	M10	121	21	4.7	35.9	195.4
80	20	13	M12	128	26.5	6.1	45.4	221
100	20	13	M12	138	26.5	6.1	49.3	238.8
125	–	17	M16	160	40	8	65	290

Standard cylinders DSBG, to ISO 15552

1



- Sturdy tie rod design
- Strokes of up to 2,800 mm
- PPS cushioning with ample cushioning capacity
- Wide range of variants for customised applications
- Comprehensive range of mounting accessories for just about every type of installation
- Spare parts service

→ www.festo.com/catalogue/dsbg

Product range overview

Type/function	Piston Ø [mm]	Stroke [mm]	Force [N]	Product options												
				Q	T	F	P	PPS	PPV	A	N3	T1	T4	A3	V	...E
DSBG																
Double-acting	32, 40, 50, 63, 80, 100, 125	1 ... 2,800	483 ... 7,363	■	■	■	■	■	■	■	■	■	■	■	■	■

Product options

Q	With protection against rotation	P	Elastic cushioning rings/pads at both ends	R3	High corrosion protection	A3	Suitable for unlubricated operation
L	Low friction	PPS	Pneumatic cushioning, self-adjusting at both ends	T1	Heat-resistant seals up to max. 120 °C	V	Swivel mounting position
U	Uniformly slow movement	PPV	Pneumatic cushioning, adjustable at both ends	T3	Low temperature	E	Piston rod extension
T	Through piston rod	A	Position sensing	T4	Heat-resistant seals up to max. 150 °C	L	Piston rod thread extension
F	Female piston rod thread	N3	Standard conforms to ISO 15552	P2	Bellows on bearing cap		
				A2	Hard scraper		

Technical data

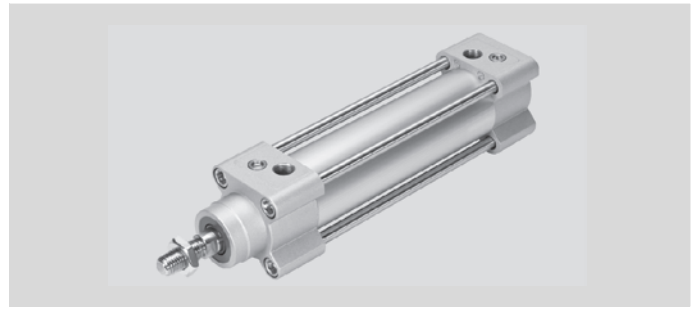
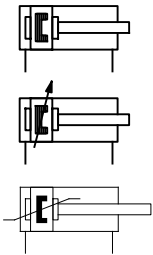

Technical data		Dimensions → 54						
Piston Ø		32	40	50	63	80	100	125
Pneumatic connection		G $\frac{1}{8}$	G $\frac{1}{4}$	G $\frac{1}{4}$	G $\frac{3}{8}$	G $\frac{3}{8}$	G $\frac{1}{2}$	G $\frac{1}{2}$
Piston rod thread		M10x1.25	M12x1.25	M16x1.5	M16x1.5	M20x1.5	M20x1.5	M27x2
Cushioning	P	Elastic cushioning rings/pads at both ends						
	PPV	Pneumatic cushioning, adjustable at both ends						
	PPS	Pneumatic cushioning, self-adjusting at both ends						
Cushioning length	[mm]	20	20	22	22	32	32	46
Theoretical force at 6 bar, advancing	[N]	483	754	1,178	1,870	3,016	4,712	7,363
Theoretical force at 6 bar, retracting	[N]	415	633	990	1,682	2,721	4,418	6,881
Max. impact energy in the end positions		0.4	0.7	1.0	1.3	1.8	2.5	3.3
	T1	0.2	0.35	0.5	0.65	0.9	1.25	1.65

Operating conditions		Dimensions → 54						
Piston Ø		32	40	50	63	80	100	125
Operating pressure	[bar]	0.6 ... 12			0.4 ... 12			0.2 ... 10
	A3	1.5 ... 12			1 ... 12	0.6 ... 12		0.6 ... 10
Ambient temperature ¹⁾	[°C]	-20 ... +80						
	T1	0 ... +120						
	T4	0 ... +150						

1) Note operating range of proximity sensors.

Materials	
Piston rod	High-alloy steel
Bearing cap	Coated die-cast aluminium
Cylinder barrel	Anodised wrought aluminium alloy
End cap	Coated die-cast aluminium
Seals	TPE-U (PU), NBR

Ordering – Product options

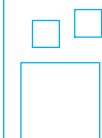

Configurable product

This product and all its options can be ordered using the configurator.

The configurator can be found under Products on the DVD or

→ www.festo.com/catalogue/...

Enter the type code in the search field.

Accessories

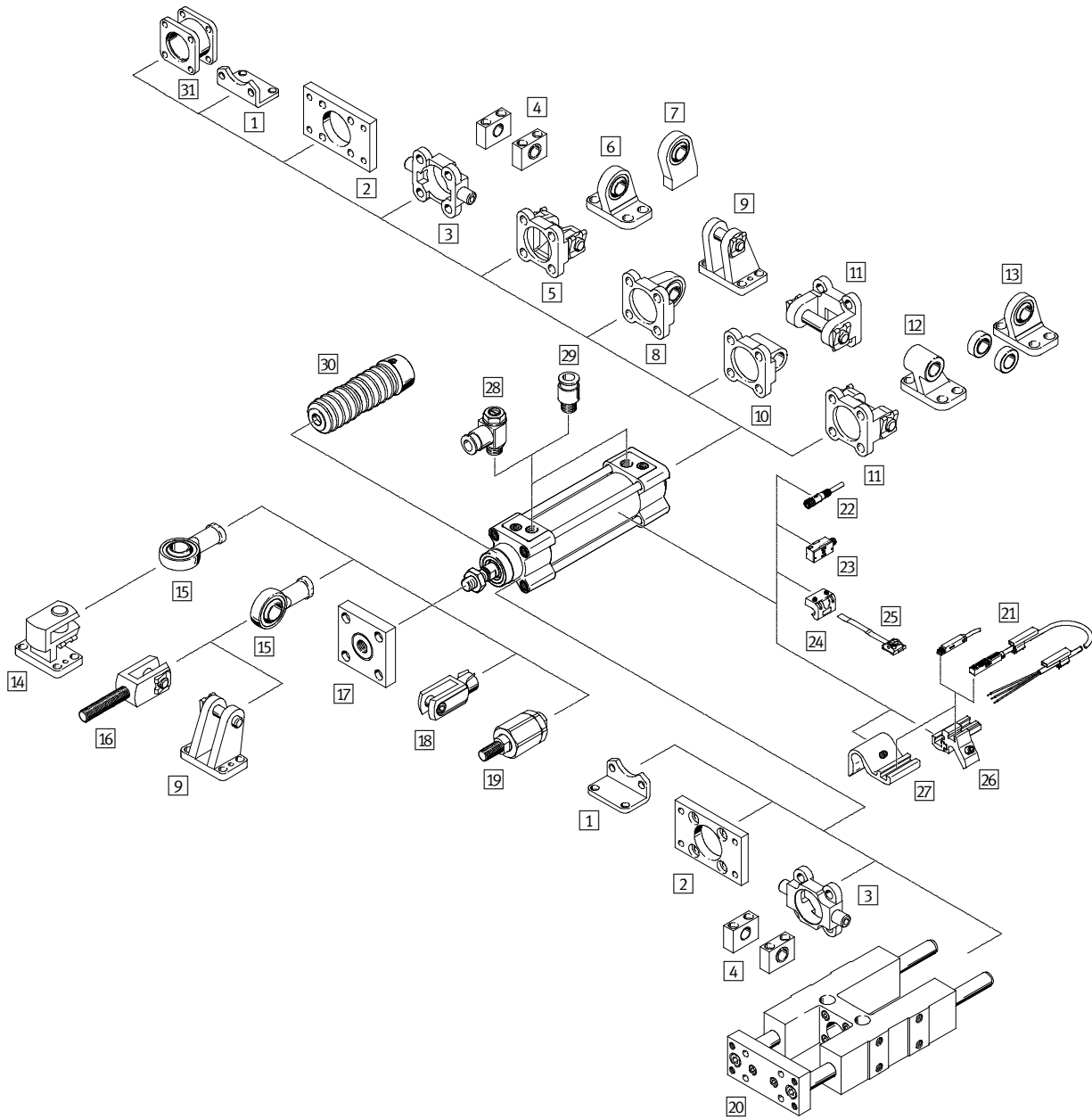



		→ Page/online
1	Foot mounting HNC Foot mounting CRHNC	50 dsbg
2	Flange mounting FNC Flange mounting CRFNG	50 dsbg
3	Trunnion flange ZNCF Trunnion flange CRZNG	50 dsbg
4	Trunnion support LNZG Trunnion support CRLNZG	50 dsbg
5	Swivel flange SNC	50
6	Clevis foot LSNG	50
7	Clevis foot LSNSG	50
8	Swivel flange SNCS	50
9	Clevis foot LBG	50
10	Swivel flange SNCL	50
11	Swivel flange SNCB	50
12	Clevis foot LNG	50
13	Clevis foot LSN	50
14	Right-angle clevis foot LQG	51
15	Rod eye SGS/CRSGS	51

		→ Page/online
16	Rod clevis SGA	51
17	Coupling piece KSG Coupling piece KSZ	51 51
18	Rod clevis SG Rod clevis CRSG	51 dsbg
19	Self-aligning rod coupler FK	51
20	Guide unit FENG	51
21	Proximity sensor SME/SMT-8M	51
22	Connecting cable NEBU	52
23	Proximity sensor SMEO-1/SMT0-1/SMPO-1	52
24	Mounting kit SMB	52
25	Mounting kit SMBS	52
26	Mounting kit SMBZ	53
27	Mounting kit DASP	53
28	One-way flow control valve GRLA	53
29	Push-in fitting QS	908
30	Protective bellows kit DADB	dsbg
31	Multi-position kit DPNC	53

Standard cylinders DSBG, to ISO 15552

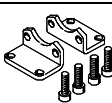
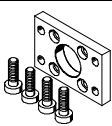
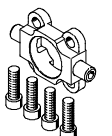
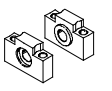
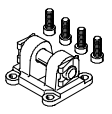
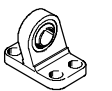

Accessories – Ordering data

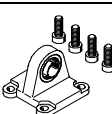
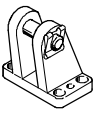
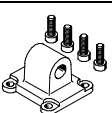
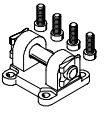
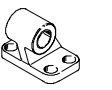
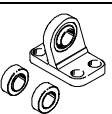

1

	For Ø		Part No.	Type
1 Foot mounting Dimensions online: → dsbg				
	32	★	174369	HNC-32
	40	★	174370	HNC-40
	50		174371	HNC-50
	63	★	174372	HNC-63
	80		174373	HNC-80
	100		174374	HNC-100
	125		174375	HNC-125
2 Flange mounting Dimensions online: → dsbg				
	32	★	174376	FNC-32
	40	★	174377	FNC-40
	50		174378	FNC-50
	63	★	174379	FNC-63
	80		174380	FNC-80
	100		174381	FNC-100
	125		174382	FNC-125
3 Trunnion flange Dimensions online: → dsbg				
	32		174411	ZNCF-32
	40		174412	ZNCF-40
	50		174413	ZNCF-50
	63		174414	ZNCF-63
	80		174415	ZNCF-80
	100		174416	ZNCF-100
	125		174417	ZNCF-125
4 Trunnion support Dimensions online: → dsbg				
	32		32959	LNZG-32
	40, 50		32960	LNZG-40/50
	63, 80		32961	LNZG-63/80
	100, 125		32962	LNZG-100/125
5 Swivel flange Dimensions online: → dsbg				
	32	★	174383	SNC-32
	40	★	174384	SNC-40
	50	★	174385	SNC-50
	63	★	174386	SNC-63
	80		174387	SNC-80
	100		174388	SNC-100
	125		174389	SNC-125
6 Clevis foot Technical data online: → lsng				
	32		31740	LSNG-32
	40		31741	LSNG-40
	50		31742	LSNG-50
	63		31743	LSNG-63
	80		31744	LSNG-80
	100		31745	LSNG-100
	125		31746	LSNG-125
7 Clevis foot Technical data online: → lsnsg				
	32		31747	LSNSG-32
	40		31748	LSNSG-40
	50		31749	LSNSG-50
	63		31750	LSNSG-63
	80		31751	LSNSG-80
	100		31752	LSNSG-100
	125		31753	LSNSG-125

	For Ø		Part No.	Type
8 Swivel flange Dimensions online: → dsbg				
	32	★	174397	SNCS-32
	40	★	174398	SNCS-40
	50	★	174399	SNCS-50
	63	★	174400	SNCS-63
	80		174401	SNCS-80
	100		174402	SNCS-100
	125		174403	SNCS-125
	9 Clevis foot Technical data online: → lbg			
	32		31761	LBG-32
	40		31762	LBG-40
	50		31763	LBG-50
	63		31764	LBG-63
	80		31765	LBG-80
	100		31766	LBG-100
	125		31767	LBG-125
	10 Swivel flange Dimensions online: → dsbg			
	32	★	174404	SNCL-32
	40	★	174405	SNCL-40
	50		174406	SNCL-50
	63	★	174407	SNCL-63
	80		174408	SNCL-80
	100		174409	SNCL-100
	125		174410	SNCL-125
	11 Swivel flange Dimensions online: → dsbg			
	32	★	174390	SNCB-32
	40	★	174391	SNCB-40
	50	★	174392	SNCB-50
	63	★	174393	SNCB-63
	80		174394	SNCB-80
	100		174395	SNCB-100
	125		174396	SNCB-125
	12 Clevis foot Technical data online: → lng			
	32	★	33890	LNG-32
	40	★	33891	LNG-40
	50	★	33892	LNG-50
	63	★	33893	LNG-63
	80		33894	LNG-80
	100		33895	LNG-100
	125		33896	LNG-125
	13 Clevis foot Technical data online: → lsn			
	32		5561	LSN-32
	40		5562	LSN-40
	50		5563	LSN-50
	63		5564	LSN-63
	80		5565	LSN-80
	100		5566	LSN-100
	125		6987	LSN-125

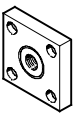
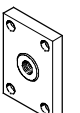
Accessories – Ordering data

	For Ø	Part No.	Type
14 Right-angle clevis foot Technical data online: → lqg			
	32	31768	LQG-32
	40	31769	LQG-40
	50	31770	LQG-50
	63	31771	LQG-63
	80	31772	LQG-80
	100	31773	LQG-100
	125	31774	LQG-125
15 Rod eye Technical data online: → sgs			
	32	★ 9261	SGS-M10x1,25
	40	★ 9262	SGS-M12x1,25
	50, 63	★ 9263	SGS-M16x1,5
	80, 100	9264	SGS-M20x1,5
	125	10774	SGS-M27x2
	16 Rod clevis Technical data online: → sga		
	32	32954	SGA-M10x1,25
	40	10767	SGA-M12x1,25
	50, 63	10768	SGA-M16x1,5
	80, 100	10769	SGA-M20x1,5
	125	10770	SGA-M27x2
	17 Coupling piece Technical data online: → ksg		
	32	32963	KSG-M10x1,25
	40	32964	KSG-M12x1,25
	50, 63	32965	KSG-M16x1,5
	80, 100	32966	KSG-M20x1,5
	125	32967	KSG-M27x2
17 Coupling piece Technical data online: → ksz			
	32	36125	KSZ-M10x1,25
	40	36126	KSZ-M12x1,25
	50, 63	36127	KSZ-M16x1,5
	80, 100	36128	KSZ-M20x1,5

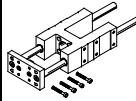
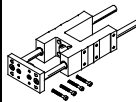
	For Ø	Part No.	Type
18 Rod clevis Technical data online: → sg			
	32	★ 6144	SG-M10x1,25
	40	★ 6145	SG-M12x1,25
	50, 63	★ 6146	SG-M16x1,5
	80, 100	6147	SG-M20x1,5
	125	14987	SG-M27x2-B
	19 Self-aligning rod coupler Technical data online: → fk		
	32	★ 6140	FK-M10x1,25
	40	★ 6141	FK-M12x1,25
	50, 63	★ 6142	FK-M16x1,5
	80, 100	6143	FK-M20x1,5
	125	10485	FK-M27x2
20 Guide unit for variable strokes from 10 ... 500 mm, with recirculating ball bearing guide Technical data online: → feng			
	32	34487	FENG-32-...-KF ¹⁾
	40	34488	FENG-40-...-KF ¹⁾
	50	34489	FENG-50-...-KF ¹⁾
	63	34490	FENG-63-...-KF ¹⁾
	80	34491	FENG-80-...-KF ¹⁾
	100	34492	FENG-100-...-KF ¹⁾
	20 Guide unit for variable strokes from 10 ... 500 mm, with plain-bearing guide Technical data online: → feng		
	32	34481	FENG-32-... ¹⁾
	40	34482	FENG-40-... ¹⁾
	50	34483	FENG-50-... ¹⁾
	63	34484	FENG-63-... ¹⁾
	80	34485	FENG-80-... ¹⁾
	100	34486	FENG-100-... ¹⁾



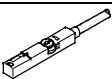
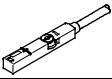





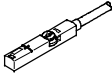

1) Enter required stroke. Order example: the order code for an appropriate guide unit for the standard cylinder DSBG-40-250 is FENG-40-250-KF (guide unit FENG - piston diameter 40 mm - stroke 250 mm - with recirculating ball bearing guide).

	For Ø	Part No.	Type
21 Proximity sensor for T-slot, magneto-resistive – N/O contact Technical data → 737			
	PNP, cable	★ 574335	SMT-8M-A-PS-24V-E-2,5-OE
	PNP, plug	★ 574334	SMT-8M-A-PS-24V-E-0,3-M8D
	PNP, plug	★ 574337	SMT-8M-A-PS-24V-E-0,3-M12
	NPN, cable	★ 574338	SMT-8M-A-NS-24V-E-2,5-OE
	NPN, plug	★ 574339	SMT-8M-A-NS-24V-E-0,3-M8D
Magneto-resistive – N/C contact Technical data → 737			
	PNP, cable	★ 574340	SMT-8M-A-PO-24V-E-7,5-OE



Standard cylinders DSBG, to ISO 15552

Accessories – Ordering data

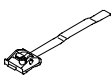
1

	For Ø		Part No.	Type	
21	Proximity sensor for T-slot, magnetic reed – N/O contact				Technical data → 732
	Cable	★	543862	SME-8M-DS-24V-K-2,5-OE	
	Cable	★	543863	SME-8M-DS-24V-K-5,0-OE	
	Cable	★	543872	SME-8M-ZS-24V-K-2,5-OE	
	Plug	★	543861	SME-8M-DS-24V-K-0,3-M8D	
					Technical data → 734
	Cable	★	150855	SME-8-K-LED-24	
	Plug		150857	SME-8-S-LED-24	
Magnetic reed – N/C contact					Technical data → 734
	Cable		160251	SME-8-O-K-LED-24	
22	Connecting cable, straight socket				Technical data → 949
	2.5 m	★	541333	NEBU-M8G3-K-2.5-LE3	
	5 m	★	541334	NEBU-M8G3-K-5-LE3	
	2.5 m		541363	NEBU-M12G5-K-2.5-LE3	
	5 m		541364	NEBU-M12G5-K-5-LE3	
Connecting cable, angled socket					Technical data → 949
	2.5 m	★	541338	NEBU-M8W3-K-2.5-LE3	
	5 m	★	541341	NEBU-M8W3-K-5-LE3	
	2.5 m		541367	NEBU-M12W5-K-2.5-LE3	
	5 m		541370	NEBU-M12W5-K-5-LE3	
23	Proximity sensor in block design, magnetic reed – N/O contact				Technical data online: → smeo
	Cable		30459	SMEO-1-LED-24-B	
	Cable		151672	SMEO-1-LED-24-K5-B	
	Plug		150848	SMEO-1-S-LED-24-B	
Magneto-resistive – N/O contact					Technical data online: → smto
	Cable		151683	SMT0-1-PS-K-LED-24-C	
	Plug		151685	SMT0-1-PS-S-LED-24-C	
	Cable		151684	SMT0-1-NS-K-LED-24-C	
	Plug		151686	SMT0-1-NS-S-LED-24-C	
Pneumatic					Technical data online: → smpo
	–		31008	SMPO-1-H-B	
24	Mounting kit for proximity sensor SMEO/SMT0-1				
	32, 40, 50		36162	SMB-2-B	
	63, 80, 100		36163	SMB-3-B	
	125		11886	SMB-1	
25	Mounting kit for proximity sensor SMPO-1				
	32, 40, 50, 63, 80, 100		151226	SMBS-2	

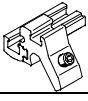
Accessories – Ordering data

	For Ø	Part No.	Type
26 Mounting kit for proximity sensor SME/SMT-8			
	32, 40, 50, 63, 80, 100	537806	SMBZ-8-32/100
	32, 40, 50, 63, 80, 100	★ 538937	SMBR-8-8/100-S6
27 Mounting kit for proximity sensor SME/SMT-8			
	125	1451483	DASP-M4-125-A

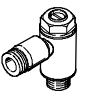
Function	For Ø	Connection		Part No.	Type
		Thread	O.D.		
28 One-way flow control valve for exhaust air flow control¹⁾ with slotted head screw, metal Technical data → 609					
	32	G $\frac{1}{8}$	4	★ 193143	GRLA- $\frac{1}{8}$ -QS-4-D
	40, 50		6	★ 193144	GRLA- $\frac{1}{8}$ -QS-6-D
	63, 80	G $\frac{3}{8}$	8	★ 193150	GRLA- $\frac{3}{8}$ -QS-8-D
	100, 125	G $\frac{1}{2}$	12	★ 193152	GRLA- $\frac{1}{2}$ -QS-12-D

1) The recommended flow control valves are based on a tubing length to the valve of 1 m. For deviations of $\pm 50\%$, flow control valves with a bigger or smaller flow rate must be selected to guarantee the optimum flow control function and cylinder speed.

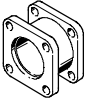
	For Ø	Part No.	Type
31 Multi-position kit Technical data online: → dsbg			
	32	174418	DPNC-32
	40	174419	DPNC-40
	50	174420	DPNC-50
	63	174421	DPNC-63
	80	174422	DPNC-80
	100	174423	DPNC-100

Standard cylinders DSBG, to ISO 15552

Dimensions

1 Basic design and A3 – Unlubricated operation

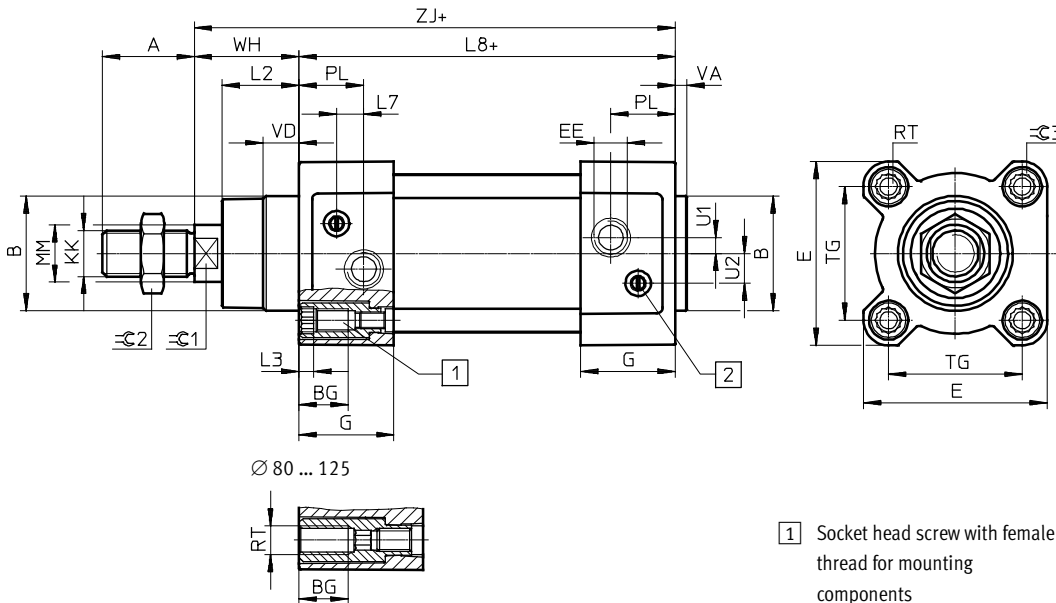

- 1 Socket head screw with female thread for mounting components
- 2 Regulating screw for adjustable end-position cushioning

Variant T – Through piston rod

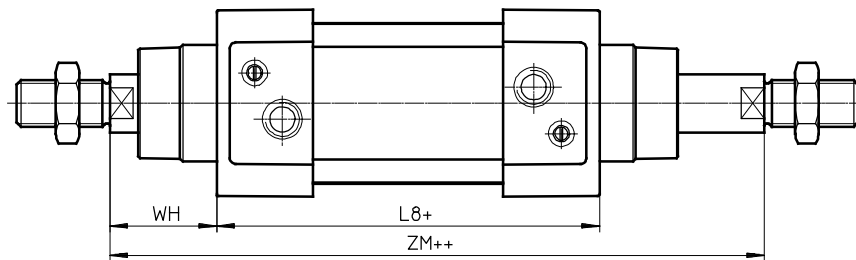

- + = plus stroke length
- ++ = plus 2x stroke length

\varnothing [mm]	A	B \varnothing d11	BG min.	E +0.5	EE	G -0.2	U2 ± 0.1	U1 ± 0.1	KK	L2	L3 max.	L7	L8 ± 0.4
32	22	30	16	45	G $\frac{1}{8}$	28	5.7	5.25	M10x1.25	18 $_{-0.2}$	5	6.5	94
40	24	35	16	54	G $\frac{1}{4}$	33	8	4	M12x1.25	21.3 $_{-0.2}$	5	7.5	105
50	32	40	17	64	G $\frac{1}{4}$	33	10.4	5.5	M16x1.5	26.8 $_{-0.2}$	5	9.5	106
63	32	45	17	75	G $\frac{3}{8}$	40.5	12.75	6.25	M16x1.5	27 $_{-0.2}$	5	9	121
80	40	45	17	93	G $\frac{3}{8}$	43	12.5	8	M20x1.5	34.2 $_{-0.2}$	-	11	128
100	40	55	17	110	G $\frac{1}{2}$	48	13.5	10	M20x1.5	38 $_{-0.2}$	-	7.5	138
125	54	60	20	136	G $\frac{1}{2}$	44.7	13	8	M27x2	45 $_{-0.3}$	-	10	160

\varnothing [mm]	MM \varnothing	PL ± 0.1	RT	TG ± 0.3	VA ± 0.5	VD +0.5	WH +2.2	ZJ +1.8	ZM +1	$\approx \varnothing 1$	$\approx \varnothing 2$	$\approx \varnothing 3$
32	12	19.5	M6	32.5	4 $_{-0.2}$	10	25	119.1	146.1	10	16	6
40	16	22.5	M6	38	4 $_{-0.2}$	10.5	28.7	133.9	164.8	13	18	6
50	20	22.5	M8	46.5	4 $_{-0.2}$	11.5	35.6	141.8	179.8	17	24	8
63	20	27.5	M8	56.5	4 $_{-0.2}$	15	35.9	157.1	195.4	17	24	8
80	25	30	M10	72	4 $_{-0.2}$	15.7	45.4	173.6	221	22	30	6
100	25	31.5	M10	89	4 $_{-0.2}$	19.2	49.3	187.5	238.8	22	30	6
125	32	22.5	M12	110	6 $_{-0.3}$	20.5	64.1	225	290	27	41	8

Dimensions

Q – With protection against rotation

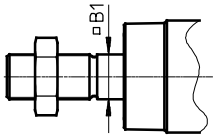

Note
Protection against rotation at one end in combination with the variant T.

F – Female thread

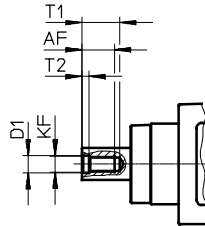

Note
Female thread at both ends in combination with the variant T.

...E – Piston rod extension

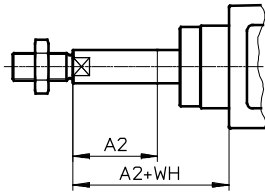

Note
Piston rod extension at one end in combination with the variant T.

...V – Swivel mounting position

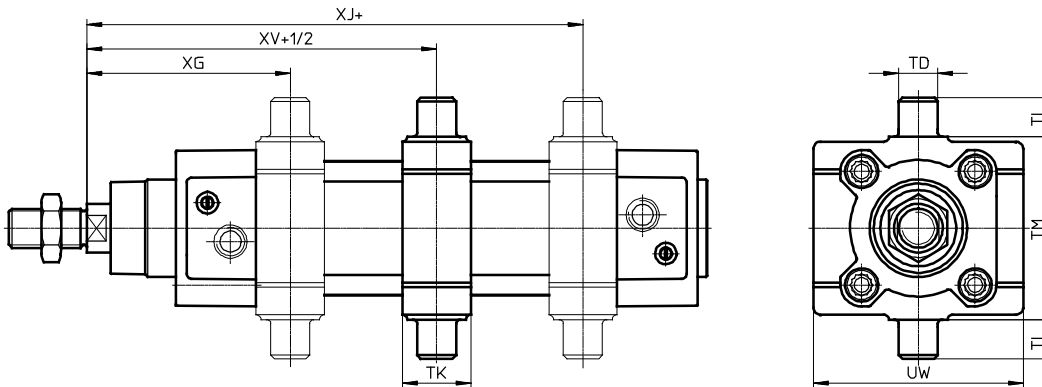

Note
The dimensions for the swivel mounting position (...V) refer to the basic design without piston rod extension. The swivel mounting can be moved at any time.

+ = plus stroke length
+1/2 = plus half stroke length

∅ [mm]	A	A1		A2		AF min.	B1	D1	KF	T1 max.
		min.	max.	min.	max.					
32	22	1	35	1	500	12	10	6.4	M6	16
40	24	1	35	1	500	12	12	8.4	M8	16
50	32	1	70	1	500	16	16	10.5	M10	21
63	32	1	70	1	500	16	16	10.5	M10	21
80	40	1	70	1	500	20	20	13	M12	26.5
100	40	1	70	1	500	20	20	13	M12	26.5
125	54	1	70	1	500	32	–	17	M16	40

∅ [mm]	T2	WH	TD ∅ e9	TK	TL h14	TM h14	UW	XG min.	XJ max.	XV
40	3.3	28.7	16	25	16	63	72	74.2±1.4	88.4±1.4	81.2±1.4
50	4.7	35.6	16	28	16	75	86	82.6±1.4	94.8±1.4	88.6±1.4
63	4.7	35.9	20	30	20	90	98	91.4±1.8	101.6±1.8	96.4±1.8
80	6.1	45.4	20	32	20	110	110	104.4±1.8	114.6±1.8	109.4±1.8
100	6.1	49.3	25	38	25	132	136	116.3±1.8	120.5±1.8	118.3±1.8
125	8	65	25	44	25	160	160	131.7±1.8	158.3±1.8	145±1.8

Standard cylinders DSBF-C, to ISO 15552, Clean Design

1



- Standard cylinder with increased corrosion protection
- Resistant to conventional cleaning agents
- Long service life thanks to optional seal for unlubricated operation
- Hygienic mounting of the proximity sensors possible
- Strokes of up to 2,800 mm
- Comprehensive range of mounting accessories for just about every type of installation
- Spare parts service

→ www.festo.com/catalogue/dsbf

Product range overview

Type/function	Piston Ø [mm]	Stroke [mm]	Force [N]	Product options									
				T	F	PPV	PPS	N3	T1	T3	A3	E	R
DSBF-C													
Double-acting	32, 40, 50, 63, 80, 100	1 ... 2,800	483 ... 4,712	■	■	■	■	■	■	■	■	■	■

Product options

T	Through piston rod	PPS	Pneumatic cushioning, self-adjusting at both ends	T1	Heat-resistant seals up to max. 120 °C	L	Piston rod thread extension
F	Female piston rod thread	A	Position sensing	T3	Low temperature	R	Mounting rail for sensors
PPV	Pneumatic cushioning, adjustable at both ends	N3	Standard conforms to ISO 15552	A3	Suitable for unlubricated operation		
				E	Piston rod extension		

Technical data

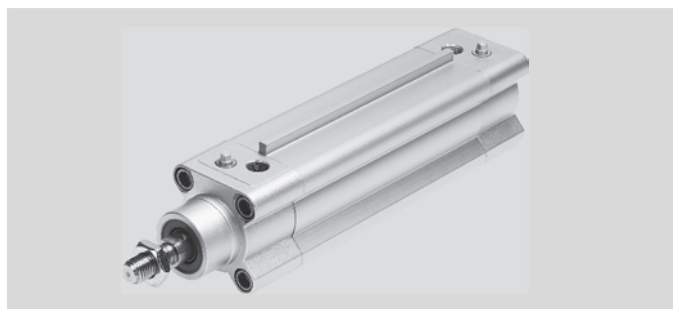
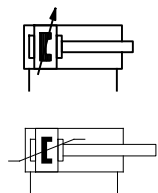

1

Technical data							Dimensions → 61
Piston Ø		32	40	50	63	80	100
Pneumatic connection		G $\frac{1}{8}$	G $\frac{1}{4}$	G $\frac{1}{4}$	G $\frac{3}{8}$	G $\frac{3}{8}$	G $\frac{1}{2}$
Piston rod thread		M10x1.25	M12x1.25	M16x1.5	M16x1.5	M20x1.5	M20x1.5
Cushioning	PPV	Pneumatic cushioning, adjustable at both ends					
	PPS	Pneumatic cushioning, self-adjusting at both ends					
Cushioning length	[mm]	20	20	22	22	32	32
Min. stroke with position sensing	[mm]	18	17	13	10	10	10
Theoretical force at 6 bar, advancing	[N]	483	754	1,178	1,870	3,016	4,712
Theoretical force at 6 bar, retracting	[N]	415	633	990	1,682	2,721	4,418
Max. impact energy in the end positions	[J]	0.4	0.7	1.0	1.3	1.8	2.5
	T1 [J]	0.2	0.35	0.5	0.65	0.9	1.25
	T3 [J]	0.2	0.35	0.5	0.65	0.9	1.25

Operating conditions							
Piston Ø		32	40	50	63	80	100
Operating pressure	[bar]	0.6 ... 12					
	T3 [bar]	1 ... 12					
	A3 [bar]	1.5 ... 12			1 ... 12		0.6 ... 12
Ambient temperature ¹⁾	[°C]	-20 ... +80					
	T1 [°C]	0 ... +120					
	T3 [°C]	-40 ... +80					

1) Note operating range of proximity sensors.

Materials	
Piston rod	High-alloy stainless steel
Bearing cap	Coated die-cast aluminium
Cylinder barrel	Anodised wrought aluminium alloy
End cap	Coated die-cast aluminium
Seals	NBR, PUR

Product options

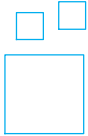

Configurable product

This product and all its options can be ordered using the configurator.

The configurator can be found under Products on the DVD or
[→ www.festo.com/catalogue/...](http://www.festo.com/catalogue/...)

Enter the type code in the search field.

Accessories

1

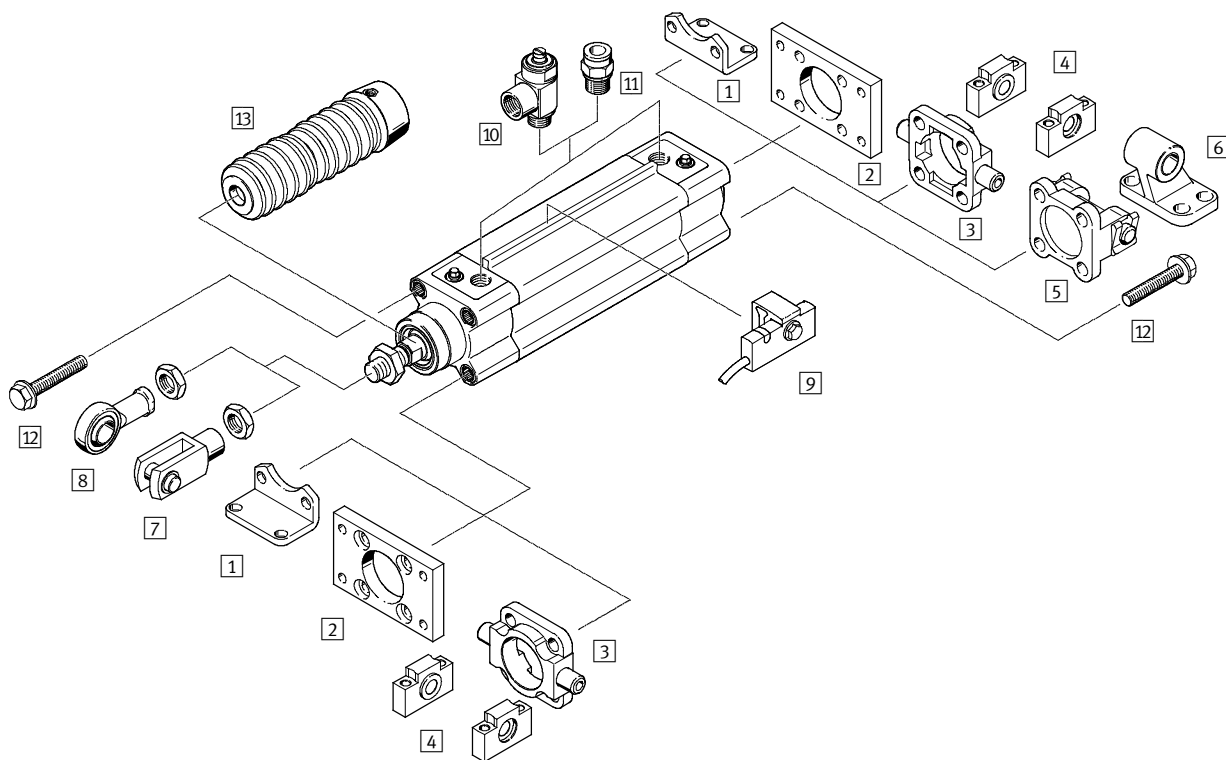



		→ Page/online
1	Foot mounting CRHNC	60
2	Flange mounting CRFNG	60
3	Trunnion flange CRZNG	60
4	Trunnion support CRLNZG	60
5	Swivel flange SNCB- ... -R3	60
6	Clevis foot CRLNG	60
7	Rod clevis CRSG	60
8	Rod eye CRSGS	60
9	Proximity sensor SMT-C1	60
10	One-way flow control valve CRGRLA	60
11	Push-in fitting QS-F/QL-F/CRQS/CRQSL	dsbf
12	Blanking screw DAMD	60
13	Protective bellows kit DADB	dsbf

Standard cylinders DSBF-C, to ISO 1552, Clean Design

Accessories – Ordering data

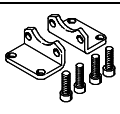
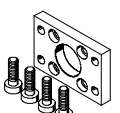
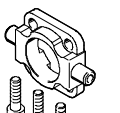
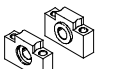

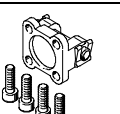
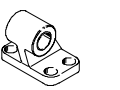
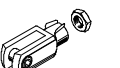
1

	For Ø	Part No.	Type
1 Foot mounting Dimensions online: → dsbf			
	32	176937	CRHNC-32
	40	176938	CRHNC-40
	50	176939	CRHNC-50
	63	176940	CRHNC-63
	80	176941	CRHNC-80
	100	176942	CRHNC-100
2 Flange mounting Dimensions online: → dsbf			
	32	161846	CRFNG-32
	40	161847	CRFNG-40
	50	161848	CRFNG-50
	63	161849	CRFNG-63
	80	161850	CRFNG-80
	100	161851	CRFNG-100
3 Trunnion flange Dimensions online: → dsbf			
	32	161852	CRZNG-32
	40	161853	CRZNG-40
	50	161854	CRZNG-50
	63	161855	CRZNG-63
	80	161856	CRZNG-80
	100	161857	CRZNG-100
4 Trunnion support Dimensions online: → dsbf			
	32	161874	CRLNZG-32
	40, 50	161875	CRLNZG-40/50
	63, 80	161876	CRLNZG-63/80
	100	161877	CRLNZG-100

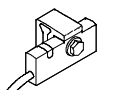
	For Ø	Part No.	Type
5 Swivel flange Dimensions online: → dsbf			
	32	176944	SNCB-32-R3
	40	176945	SNCB-40-R3
	50	176946	SNCB-50-R3
	63	176947	SNCB-63-R3
	80	176948	SNCB-80-R3
	100	176949	SNCB-100-R3
6 Clevis foot Technical data online: → crlng			
	32	161840	CRLNG-32
	40	161841	CRLNG-40
	50	161842	CRLNG-50
	63	161843	CRLNG-63
	80	161844	CRLNG-80
	100	161845	CRLNG-100
7 Rod clevis Technical data online: → crrsg			
	32	13569	CRSG-M10x1,25
	40	13570	CRSG-M12x1,25
	50, 63	13571	CRSG-M16x1,5
	80, 100	13572	CRSG-M20x1,5
8 Rod eye Technical data online: → crrsgs			
	32	195582	CRSGS-M10x1,25
	40	195583	CRSGS-M12x1,25
	50, 63	195584	CRSGS-M16x1,5
	80, 100	195585	CRSGS-M20x1,5

	For Ø	Part No.	Type
9 Proximity sensor, magneto-resistive – N/O contact Technical data online: → smt			
	PNP, cable	571339	SMT-C1-PS-24V-K-5,0-OE
	PNP, plug	571342	SMT-C1-PS-24V-K-0,3-M8D
	PNP, plug	571341	SMT-C1-PS-24V-K-0,3-M12

	For Ø	Connection	Part No.	Type
		Thread		
10 One-way flow control valve with slotted head screw, stainless steel for exhaust air flow control Technical data online: → grla				
	32	G $\frac{1}{8}$	161404	CRGRLA- $\frac{1}{8}$ -B
	40, 50	G $\frac{1}{4}$	161405	CRGRLA- $\frac{1}{4}$ -B
	63, 80	G $\frac{3}{8}$	161406	CRGRLA- $\frac{3}{8}$ -B
	100	G $\frac{1}{2}$	161407	CRGRLA- $\frac{1}{2}$ -B

	For Ø	Part No.	Type
12 Blanking screw¹⁾			
	32, 40	1355016	DAMD-PS-M6-12-R1
	50, 63	650121	DAMD-PS-M8-16-R1
	80, 100	1355026	DAMD-PS-M10-16-R1
Plastic tubing Technical data online: → pln			
	32, 40, 50, 63, 80, 100	–	PLN
		–	PFAN
		–	PUN-H

1) Packaging unit 4 pieces.

Standard cylinders DSBF-C, to ISO 15552, Clean Design

Dimensions

Basic design and A3 – Unlubricated operation

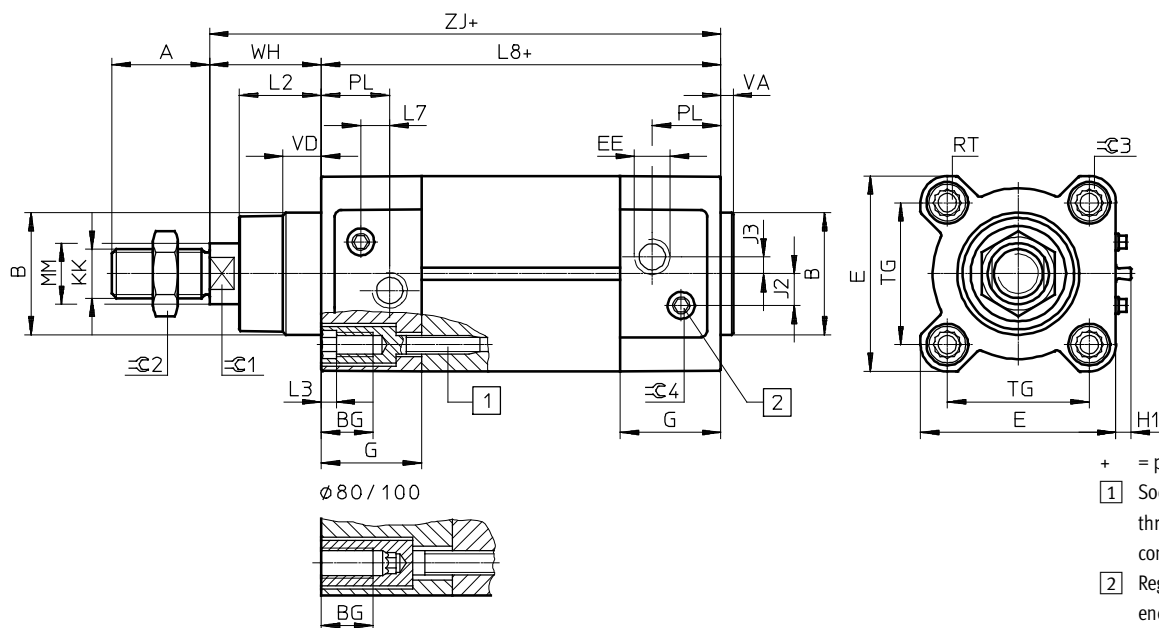

- + = plus stroke length
- 1 Socket head screw with female thread for mounting components
- 2 Regulating screw for adjustable end-position cushioning

∅	A	B	BG	E	EE	G	H1	J2	J3
[mm]	-0.5	∅ d11	min.	+0.5		-0.2	±0.2	±0.1	±0.1
32	22	30	16	45	G ¹ / ₈	28	5	5.7	5.25
40	24	35	16	54	G ¹ / ₄	33	5	8	4
50	32	40	16	64	G ¹ / ₄	33	5	10.4	5.5
63	32	45	16	75	G ³ / ₈	40.5	5	12.75	6.25
80	40	45	17	93	G ³ / ₈	43	5	12.5	8
100	40	55	17	110	G ¹ / ₂	48	5	13.5	10

∅	KK	L2	L3	L7	L8	MM	PL	RT	TG
[mm]		-0.2			±0.4	∅	±0.1		±0.3
32	M10x1.25	18	max. 5	6.5	94	12	19.5	M6	32.5
40	M12x1.25	21.3	max. 5	7.5	105	16	22.5	M6	38
50	M16x1.5	26.8	max. 5	9.5	106	20	22.5	M8	46.5
63	M16x1.5	27	max. 5	9	121	20	27.5	M8	56.5
80	M20x1.5	34.2	-	11	128	25	30	M10	72
100	M20x1.5	38	-	7.5	138	25	31.5	M10	89

∅	VA	VD	WH	ZJ	∅C1	∅C2	∅C3	∅C4
[mm]	-0.2	+0.5	+2.2	+1.8				
32	4	10	26	119.1	10	16	6	4
40	4	10.5	28.7	133.9	13	18	6	4
50	4	11.5	35.6	141.8	17	24	8	4
63	4	15	35.9	157.1	17	24	8	4
80	4	15.7	45.4	173.6	22	30	6	4
100	4	19.2	49.3	187.5	22	30	6	5

Standard cylinders DSBF-C, to ISO 1552, Clean Design

Dimensions

1 F – Piston rod with female thread

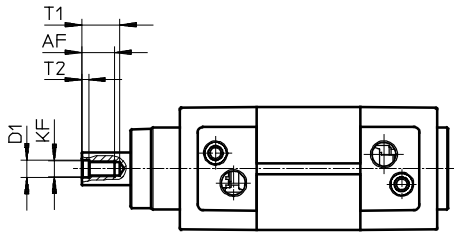

E – Piston rod extension

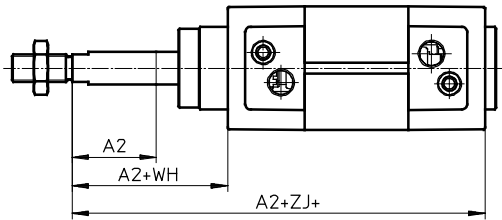

Note
Piston rod extension at one end in combination with the variant T.

+ = plus stroke length

T – Through piston rod

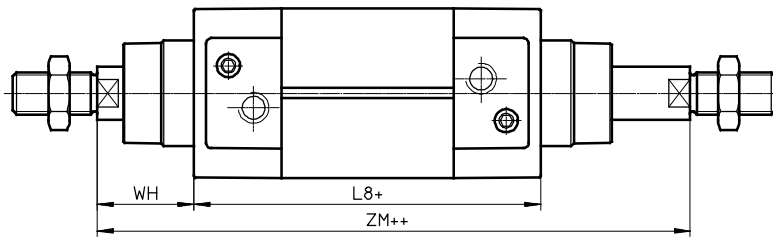

+ = plus stroke length
++ = plus 2x stroke length

∅ [mm]	A1 max.	A2 max.	AM	AF	D1	KF
32	35	500	22	12	6.4	M6
40	70		24	12	8.4	M8
50			32	16	10.5	M10
63			32	16	10.5	M10
80			40	20	13	M12
100			40	20	13	M12

∅ [mm]	KK	L8 ±0.4	T1	T2	WH +2.2	ZJ +1.8	ZM +1
32	M10x1.25	94	16	2.6	26	119.1	146.1
40	M12x1.25	105	16	3.3	28.7	133.9	164.8
50	M16x1.5	106	21	4.7	35.6	141.8	179.8
63	M16x1.5	121	21	4.7	35.9	157.1	195.4
80	M20x1.5	128	26.5	6.1	45.4	173.6	221
100	M20x1.5	138	26.5	6.1	49.3	187.5	238.8

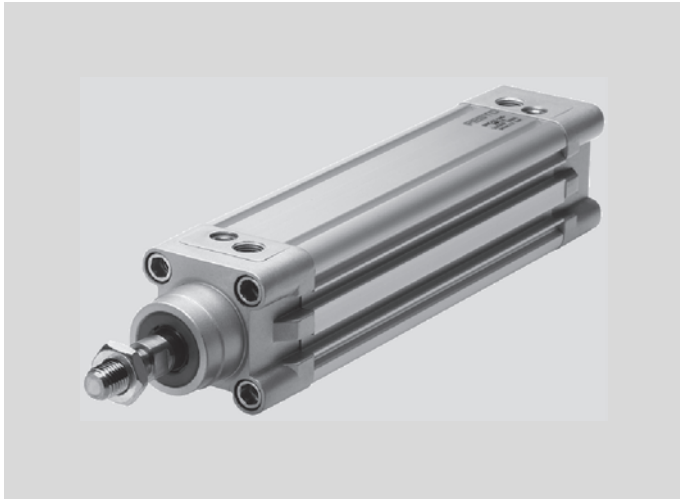

- Strokes of up to 2,000 mm
- Profile slot for proximity sensors on 3 sides
- Wide range of variants for customised applications
- Spare parts service
- Selected types in accordance with the ATEX Directive for explosive atmospheres → www.festo.com/catalogue/ex

→ www.festo.com/catalogue/dnc

Product range overview

Type/function	Piston Ø [mm]	Stroke [mm]	Force [N]	Product options							→ Page/online
				P	PPV	A	Q	S2	S6	TT	
Double-acting	DNC – Basic design										
	32, 40, 50, 63, 80, 100, 125	10 ... 2,000	415 ... 7,363	■	■	■	■	■	■	■	64
	DNC-...-KP – With clamping unit										
	32, 40, 50, 63, 80, 100, 125	10 ... 2,000	415 ... 7,363	■	■	■	■	■	-	-	dnc-kp
	DNC-...-EL – With end-position locking										
	32, 40, 50, 63, 80, 100	10 ... 2,000	415 ... 4,712	-	■	■	-	■	-	-	dnc-el
DNC-...-V1 ... V6 – Cylinder/valve combination											
32, 40, 50, 63, 80, 100	10 ... 2,000	415 ... 4,712	■	■	■	■	■	■	-	-	dnc-v

Product options

P	Elastic cushioning rings/pads at both ends	S20	Through, hollow piston rod	K7	Piston rod with external hexagon	TT	Low temperature
PPV	Pneumatic cushioning, adjustable at both ends	K2	Extended male piston rod thread	K8	Extended piston rod	S10	Slow speed
A	Position sensing	K3	Female piston rod thread	K10	Smooth anodised aluminium piston rod	S11	Low friction
Q	Square piston rod	K5	Special piston rod thread	S6	Heat-resistant seals up to max. 120 °C	R3	High corrosion protection
S2	Through piston rod					R8	Dust protection

Standard cylinders DNC, to ISO 15552

FESTO

1 Technical data

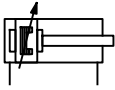
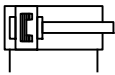

Technical data							Dimensions → 70	
Piston Ø		32	40	50	63	80	100	125
Pneumatic connection		G $\frac{1}{8}$	G $\frac{1}{4}$	G $\frac{1}{4}$	G $\frac{3}{8}$	G $\frac{3}{8}$	G $\frac{1}{2}$	G $\frac{1}{2}$
End of piston rod		Male thread						
Piston rod thread		M10x1.25	M12x1.25	M16x1.5	M16x1.5	M20x1.5	M20x1.5	M27x2
Cushioning		Elastic cushioning rings/pads at both ends						
		Pneumatic cushioning, adjustable at both ends						
Cushioning length	[mm]	20	20	22	22	32	32	42
Theoretical force at 6 bar, advancing	[N]	483	754	1,178	1,870	3,016	4,712	7,363
	S2 [N]	415	633	990	1,682	2,721	4,418	6,881
Theoretical force at 6 bar, retracting	[N]	415	633	990	1,682	2,721	4,418	6,881
Max. torque at the piston rod	Q [Nm]	0.8	1.1	1.5	1.5	3	3	–

Operating conditions				
Piston Ø		Basic design, product options		S6
		32 ... 100		125
Operating pressure	[bar]	0.6 ... 12		0.6 ... 10
Ambient temperature ¹⁾	[°C]	–20 ... +80		0 ... 120

1) Note operating range of proximity sensors.

Materials	
Piston rod	High-alloy steel
Bearing cap	Coated die-cast aluminium
Cylinder barrel	Smooth anodised aluminium
End cap	Coated die-cast aluminium
Seals	TPE-U (PU)

Order code

1

Type		DNC	-	-	-	-	-	-	-	
DNC	Double-acting standard cylinder									
Piston Ø [mm]										
	Stroke [mm]									
32, 40, 50, 63, 80, 100, 125	25, 40, 50, 80, 100, 125, 160, 200, 250, 320, 400, 500	10 ... 2,000								
32, 40, 50, 63, 80, 100, 125	20, 30, 60, 70, 150, 300	1								
Cushioning										
P	Elastic cushioning rings/pads at both ends									
PPV	Pneumatic cushioning, adjustable at both ends									
Position sensing										
-	None									
A	Via proximity sensor									
Protection against rotation										
-	None									
Q	Square piston rod 2									
Piston rod										
-	Piston rod at one end									
S2	Through piston rod									
Temperature resistance										
S6	Heat-resistant seals up to max. 120 °C									

- 1 Only with position sensing A.
 2 Not with piston Ø 125 mm.
 Max. stroke: 10 ... 1,500 mm.

Ordering – Product options

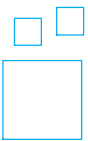

Configurable product

This product and all its options can be ordered using the configurator.

The configurator can be found under Products on the DVD or
 → www.festo.com/catalogue/...

Enter the type code in the search field.

Standard cylinders DNC, to ISO 15552

Accessories

1

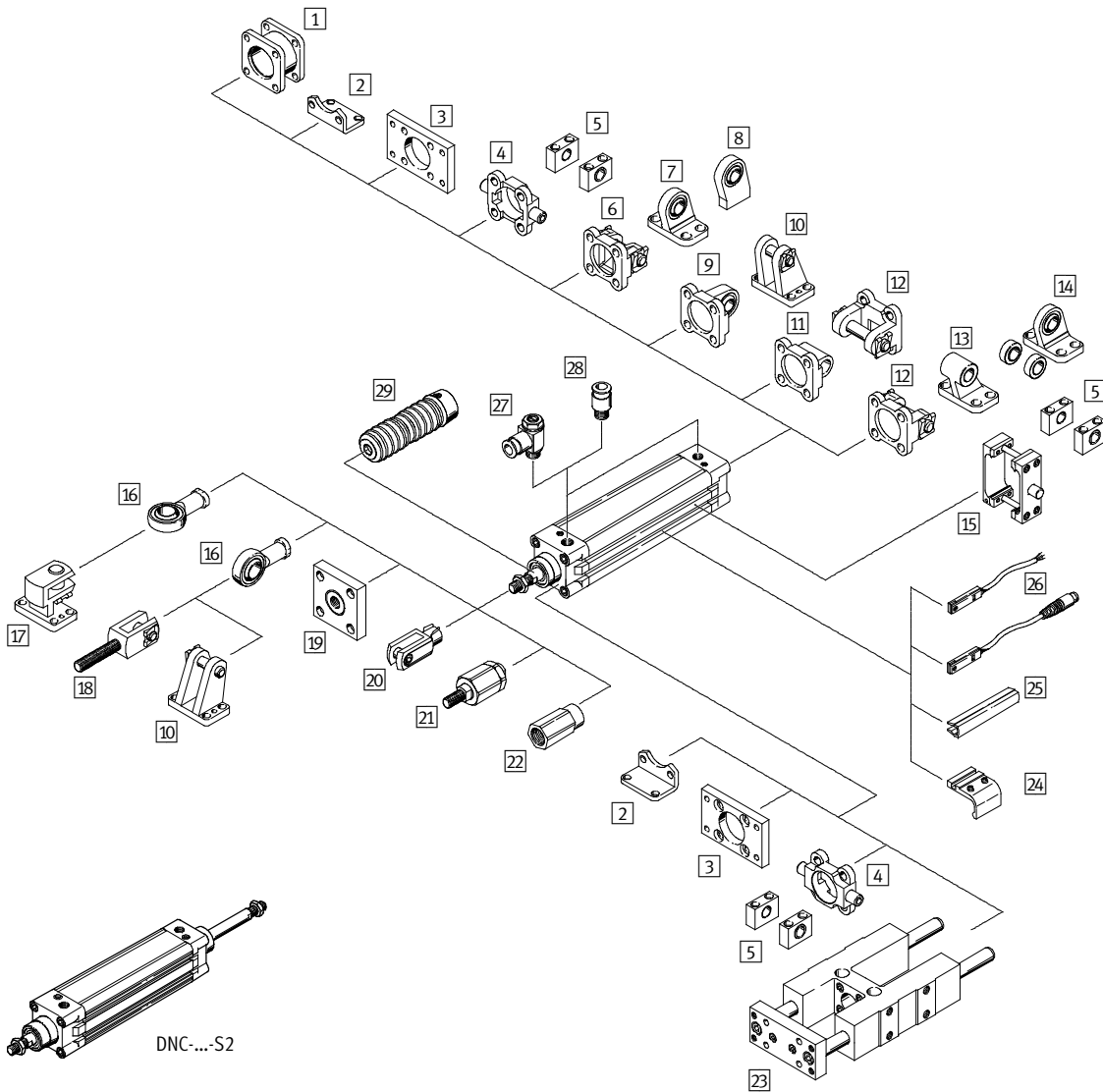





DNC-...S2

		→ Page/ online
1	Multi-position kit DPNC	67
2	Foot mounting HNC	67
	Foot mounting CRHNC	dnc
3	Flange mounting FNC	67
	Flange mounting CRFNG	dnc
4	Trunnion flange ZNCF	67
	Trunnion flange CRZNG	dnc
5	Trunnion support LNZG	67
	Trunnion support CRLNZG	dnc
6	Swivel flange SNC	67
7	Clevis foot LSNG	67
8	Clevis foot LSNSG	67
9	Swivel flange SNCS	67
10	Clevis foot LBG	67
11	Swivel flange SNCL	67
12	Swivel flange SNCB	67
	Swivel flange SNCB-R3	dnc
13	Clevis foot LNG	67
	Clevis foot CRLNG	dnc

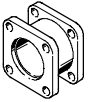
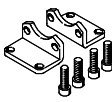
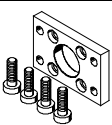
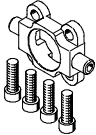
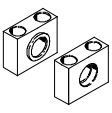
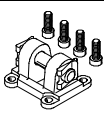
		→ Page/ online
14	Clevis foot LSN	68
15	Trunnion mounting kit DAMT	68
16	Rod eye SGS	68
	Rod eye CRSGS	dnc
17	Right-angle clevis foot LQG	68
18	Rod clevis SGA	68
19	Coupling piece KSG/KSZ	68
20	Rod clevis SG	68
	Rod clevis CRSG	dnc
21	Self-aligning rod coupler FK	68
22	Adapter AD	68
23	Guide unit FENG	68
24	Mounting kit SMB-8-FENG	68
25	Slot cover ABP-5-S	68
26	Proximity sensor SME/SMT and connecting cable NEBU	69
27	One-way flow control valve GRLA	69
28	Push-in fitting QS	908
29	Protective bellows kit DADB	dnc

Accessories – Ordering data

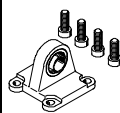
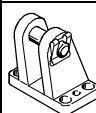
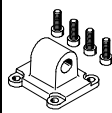
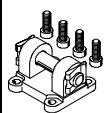



	For Ø	Part No.	Type
1 Multi-position kit Dimensions online: → dnc			
	32	174418	DPNC-32
	40	174419	DPNC-40
	50	174420	DPNC-50
	63	174421	DPNC-63
	80	174422	DPNC-80
	100	174423	DPNC-100
	125	174424	DPNC-125
2 Foot mounting Dimensions online: → dnc			
	32	★ 174369	HNC-32
	40	★ 174370	HNC-40
	50	174371	HNC-50
	63	★ 174372	HNC-63
	80	174373	HNC-80
	100	174374	HNC-100
	125	174375	HNC-125
3 Flange mounting Dimensions online: → dnc			
	32	★ 174376	FNC-32
	40	★ 174377	FNC-40
	50	174378	FNC-50
	63	★ 174379	FNC-63
	80	174380	FNC-80
	100	174381	FNC-100
	125	174382	FNC-125
4 Trunnion flange Dimensions online: → dnc			
	32	174411	ZNCF-32
	40	174412	ZNCF-40
	50	174413	ZNCF-50
	63	174414	ZNCF-63
	80	174415	ZNCF-80
	100	174416	ZNCF-100
	125	174417	ZNCF-125
5 Trunnion support Dimensions online: → dnc			
	32	32959	LNZG-32
	40, 50	32960	LNZG-40/50
	63, 80	32961	LNZG-63/80
	100, 125	32962	LNZG-100/125
6 Swivel flange Dimensions online: → dnc			
	32	★ 174383	SNC-32
	40	★ 174384	SNC-40
	50	★ 174385	SNC-50
	63	★ 174386	SNC-63
	80	174387	SNC-80
	100	174388	SNC-100
	125	174389	SNC-125
7 Clevis foot Technical data online: → lsng			
	32	31740	LSNG-32
	40	31741	LSNG-40
	50	31742	LSNG-50
	63	31743	LSNG-63
	80	31744	LSNG-80
	100	31745	LSNG-100
	125	31746	LSNG-125



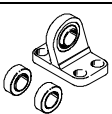
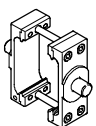

	For Ø	Part No.	Type
8 Clevis foot Technical data online: → lsnsg			
	32	31747	LSNSG-32
	40	31748	LSNSG-40
	50	31749	LSNSG-50
	63	31750	LSNSG-63
	80	31751	LSNSG-80
	100	31752	LSNSG-100
	125	31753	LSNSG-125
9 Swivel flange Dimensions online: → dnc			
	32	★ 174397	SNCS-32
	40	★ 174398	SNCS-40
	50	★ 174399	SNCS-50
	63	★ 174400	SNCS-63
	80	174401	SNCS-80
	100	174402	SNCS-100
	125	174403	SNCS-125
10 Clevis foot Technical data online: → lbg			
	32	31761	LBG-32
	40	31762	LBG-40
	50	31763	LBG-50
	63	31764	LBG-63
	80	31765	LBG-80
	100	31766	LBG-100
	125	31767	LBG-125
11 Swivel flange Dimensions online: → dnc			
	32	★ 174404	SNCL-32
	40	★ 174405	SNCL-40
	50	174406	SNCL-50
	63	★ 174407	SNCL-63
	80	174408	SNCL-80
	100	174409	SNCL-100
	125	174410	SNCL-125
12 Swivel flange Dimensions online: → dnc			
	32	★ 174390	SNCB-32
	40	★ 174391	SNCB-40
	50	★ 174392	SNCB-50
	63	★ 174393	SNCB-63
	80	174394	SNCB-80
	100	174395	SNCB-100
	125	174396	SNCB-125
13 Clevis foot Technical data online: → lng			
	32	★ 33890	LNG-32
	40	★ 33891	LNG-40
	50	★ 33892	LNG-50
	63	★ 33893	LNG-63
	80	33894	LNG-80
	100	33895	LNG-100
	125	33896	LNG-125

Standard cylinders DNC, to ISO 15552

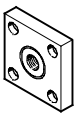
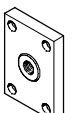
Accessories – Ordering data

1

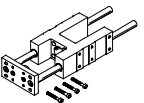
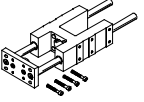





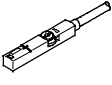
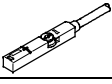
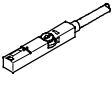

	For Ø	Part No.	Type
14 Clevis foot Technical data online: → lsn			
	32	5561	LSN-32
	40	5562	LSN-40
	50	5563	LSN-50
	63	5564	LSN-63
	80	5565	LSN-80
	100	5566	LSN-100
	125	6987	LSN-125
15 Trunnion mounting kit Dimensions online: → dnc			
	32	2213233	DAMT-V1-32-A
	40	2214899	DAMT-V1-40-A
	50	2214909	DAMT-V1-50-A
	63	2214971	DAMT-V1-63-A
	80	163529	DAMT-V1-80-A
	100	163530	DAMT-V1-100-A
	125	163531	DAMT-V7-125-A
16 Rod eye Technical data online: → sgs			
	32	★ 9261	SGS-M10x1,25
	40	★ 9262	SGS-M12x1,25
	50, 63	★ 9263	SGS-M16x1,5
	80, 100	9264	SGS-M20x1,5
	125	10774	SGS-M27x2
17 Clevis foot Technical data online: → lqg			
	32	31768	LQG-32
	40	31769	LQG-40
	50	31770	LQG-50
	63	31771	LQG-63
	80	31772	LQG-80
	100	31773	LQG-100
	125	31774	LQG-125
18 Rod clevis Technical data online: → sga			
	32	32954	SGA-M10x1,25
	40	10767	SGA-M12x1,25
	50, 63	10768	SGA-M16x1,5
	80, 100	10769	SGA-M20x1,5
	125	10770	SGA-M27x2
	19 Coupling piece Technical data online: → ksg		
	32	32963	KSG-M10x1,25
	40	32964	KSG-M12x1,25
	50, 63	32965	KSG-M16x1,5
	80, 100	32966	KSG-M20x1,5
	125	32967	KSG-M27x2
19 Coupling piece Technical data online: → ksz			
	32	36125	KSZ-M10x1,25
	40	32126	KSZ-M12x1,25
	50, 63	36127	KSZ-M16x1,5
	80, 100	36128	KSZ-M20x1,5

	For Ø	Part No.	Type
20 Rod clevis Technical data online: → sg			
	32	★ 6144	SG-M10x1,25
	40	★ 6145	SG-M12x1,25
	50, 63	★ 6146	SG-M16x1,5
	80, 100	6147	SG-M20x1,5
	125	14987	SG-M27x2-B
	21 Self-aligning rod coupler Technical data online: → fk		
	32	★ 6140	FK-M10x1,25
	40	★ 6141	FK-M12x1,25
	50, 63	★ 6142	FK-M16x1,5
	80, 100	6143	FK-M20x1,5
	125	10485	FK-M27x2
22 Adapter Technical data online: → ad			
	32	157333	AD-M10x1,25-1/8
		157334	AD-M10x1,25-1/4
	40	160256	AD-M12x1,25-1/4
		160257	AD-M12x1,25-3/8
23 Guide unit for variable strokes from 10 ... 500 mm, with recirculating ball bearing guide Technical data online: → feng			
	32	34487	FENG-32-...-KF ¹⁾
	40	34488	FENG-40-...-KF ¹⁾
	50	34489	FENG-50-...-KF ¹⁾
	63	34490	FENG-63-...-KF ¹⁾
	80	34491	FENG-80-...-KF ¹⁾
	100	34492	FENG-100-...-KF ¹⁾
23 Guide unit for variable strokes from 10 ... 500 mm, with plain-bearing guide Technical data online: → feng			
	32	34481	FENG-32-... ¹⁾
	40	34482	FENG-40-... ¹⁾
	50	34483	FENG-50-... ¹⁾
	63	34484	FENG-63-... ¹⁾
	80	34485	FENG-80-... ¹⁾
	100	34486	FENG-100-... ¹⁾
24 Mounting kit for proximity sensor, for SMT-/SME-8 in combination with guide unit FENG			
	32, 40	175705	SMB-8-FENG-32/40
	50, 63	175706	SMB-8-FENG-50/63
	80, 100	175707	SMB-8-FENG-80/100
25 Slot cover²⁾			
		151680	ABP-5-S

1) Enter required stroke. Order example: the order code for an appropriate guide unit for the standard cylinder DNC-40-250 is FENG-40-250-KF (guide unit FENG - piston diameter 40 mm - stroke 250 mm - with recirculating ball bearing guide).

2) Packaging unit 2x 0.5 m.

Accessories – Ordering data

	For Ø		Part No.	Type	
26 Proximity sensor for T-slot, magneto-resistive – N/O contact Technical data → 737					
	PNP, cable	★	574335	SMT-8M-A-PS-24V-E-2,5-OE	
	PNP, plug	★	574334	SMT-8M-A-PS-24V-E-0,3-M8D	
	PNP, plug	★	574337	SMT-8M-A-PS-24V-E-0,3-M12	
	NPN, cable	★	574338	SMT-8M-A-NS-24V-E-2,5-OE	
	NPN, plug	★	574339	SMT-8M-A-NS-24V-E-0,3-M8D	
Magneto-resistive – N/C contact Technical data → 737					
	PNP, cable	★	574340	SMT-8M-A-PO-24V-E-7,5-OE	
26 Proximity sensor for T-slot, magnetic reed – N/O contact Technical data → 732					
	Cable	★	543862	SME-8M-DS-24V-K-2,5-OE	
	Cable	★	543863	SME-8M-DS-24V-K-5,0-OE	
	Cable	★	543872	SME-8M-ZS-24V-K-2,5-OE	
	Plug	★	543861	SME-8M-DS-24V-K-0,3-M8D	
Technical data → 734					
	Cable	★	150855	SME-8-K-LED-24	
	Plug		150857	SME-8-S-LED-24	
Magnetic reed – N/C contact Technical data → 734					
	Cable		160251	SME-8-O-K-LED-24	
26 Connecting cable, straight socket Technical data → 949					
	2.5 m	★	541333	NEBU-M8G3-K-2.5-LE3	
	5 m	★	541334	NEBU-M8G3-K-5-LE3	
	2.5 m		541363	NEBU-M12G5-K-2.5-LE3	
	5 m		541364	NEBU-M12G5-K-5-LE3	
Angled socket Technical data → 949					
	2.5 m	★	541338	NEBU-M8W3-K-2.5-LE3	
	5 m	★	541341	NEBU-M8W3-K-5-LE3	
	2.5 m		541367	NEBU-M12W5-K-2.5-LE3	
	5 m		541370	NEBU-M12W5-K-5-LE3	
Function	For Ø	Connection		Part No.	Type
		Thread	O.D.		
27 One-way flow control valve for exhaust air flow control¹⁾ with slotted head screw, metal Technical data → 611					
	32	G $\frac{1}{8}$	4	★	193143 GRLA- $\frac{1}{8}$ -QS-4-D
	40, 50		6	★	193144 GRLA- $\frac{1}{8}$ -QS-6-D
	63, 80	G $\frac{3}{8}$	8	★	193150 GRLA- $\frac{3}{8}$ -QS-8-D
	100, 125	G $\frac{1}{2}$	12	★	193152 GRLA- $\frac{1}{2}$ -QS-12-D

1) The recommended flow control valves are based on a tubing length to the valve of 1 m. For deviations of ±50%, flow control valves with a bigger or smaller flow rate must be selected to guarantee the optimum flow control function and cylinder speed.

Standard cylinders DNC, to ISO 15552

Dimensions

1

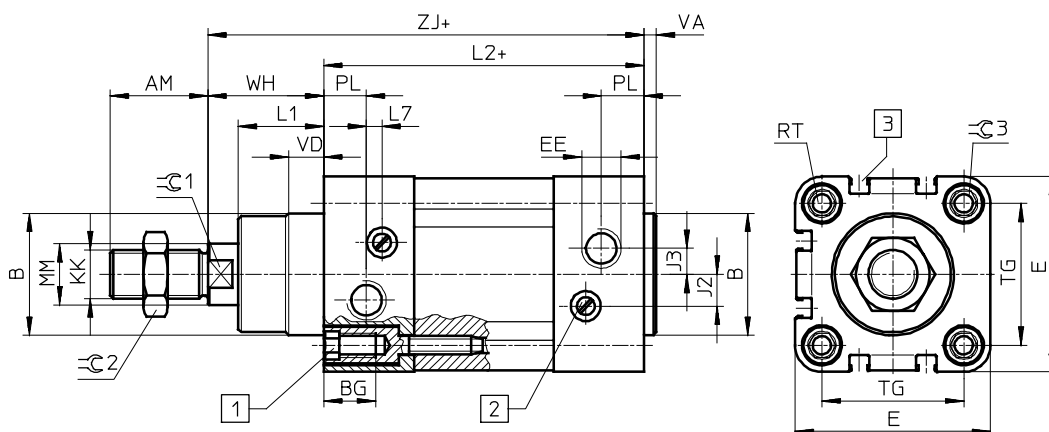

- 1 Socket head screw with female thread for mounting attachments
 - 2 Regulating screw for adjustable end-position cushioning
 - 3 Slot for proximity sensor SME/SMT-8
- + = plus stroke length

S2 – Through piston rod

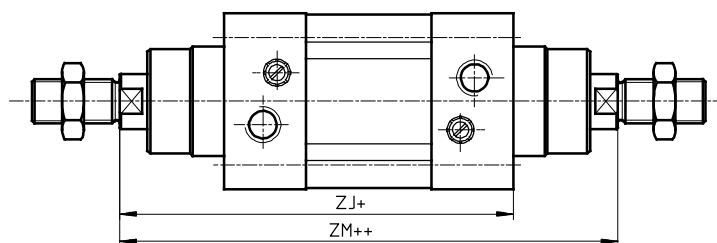

Q – Square piston rod

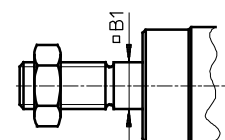

Note
 The thread types at both piston rod ends are identical. In combination with variant Q, the left-hand piston rod end is square, the right-hand piston rod end is round.
 + = plus stroke length
 ++ = plus 2x stroke length

∅	AM	B ∅ d11	B1 □	BG	E	EE	J2	J3	KK	L1	L2	L7
32	22	30	10	16	45	G ³ / ₈	6	5.2	M10x1.25	18	94	3.3
40	24	35	12	16	54	G ¹ / ₄	8	6	M12x1.25	21.5	105	3.6
50	32	40	16	17	64	G ¹ / ₄	10.4	8.5	M16x1.5	28	106	5.1
63	32	45	16	17	75	G ³ / ₈	12.4	10	M16x1.5	28.5	121	6.6
80	40	45	20	17	93	G ³ / ₈	12.5	8	M20x1.5	34.7	128	10.5
100	40	55	20	17	110	G ¹ / ₂	12	10	M20x1.5	38.2	138	8
125	54	60	-	22	134	G ¹ / ₂	13	8	M27x2	46	160	14

∅	MM ∅	PL	RT	TG	VA	VD	WH	ZJ	ZM	∅C1	∅C2	∅C3
32	12	15.6	M6	32.5	4	10	26	120	148	10	16	6
40	16	14	M6	38	4	10.5	30	135	167	13	18	6
50	20	14	M8	46.5	4	11.5	37	143	183	17	24	8
63	20	17	M8	56.5	4	15	37	158	199	17	24	8
80	25	16.4	M10	72	4	15.7	46	174	222	22	30	6
100	25	18.8	M10	89	4	19.2	51	189	240	22	30	6
125	32	18	M12	110	6	20.5	65	225	291	27	36	8

Standard cylinders DSNU/DSNUP/DSN/ESNU/ESN, to ISO 6432



- For the highest requirements for running characteristics, service life and load carrying ability
- Universal use thanks to individual product options
- Wide range of accessories
- Selected types in accordance with the ATEX Directive for explosive atmospheres → www.festo.com/catalogue/ex
- ★ Quick ordering of basic designs → 75

→ www.festo.com/catalogue/dsnu

Product range overview

Type/function	Version	Piston Ø [mm]	Stroke [mm]	Force [N]	Product options										→ Page/online
					P	PPV	PPS	A	Q	S2	KP	K8	S6		
Double-acting	DSNU – Cylinder barrel: Stainless steel; End caps: Wrought aluminium alloy														
	Basic design	8, 10, 12, 16, 20, 25	1 ... 500	30 ... 295	■	■	■	■	■	■	■	■	■	■	72
	MQ – Plain end cap, lateral connection				■	■	■	■	■	-	■	■	■		
	MA – Plain end cap, axial connection				■	-	-	■	■	-	■	■	■	dsnu	
	MH – Direct mounting				■	■	-	■	■	-	-	■	■		
	DSNU – Round cylinder with piston Ø 32 ... 63														
	91														
Double-acting	DSNUP – Cylinder barrel: Wrought aluminium alloy; End caps: Polyamide														
	Basic design	16, 20, 25	25 ... 100	121 ... 295	■	-	-	■	-	-	-	-	-	77	
	DSN														
	Basic design	8, 10, 12, 16, 20, 25	1 ... 500	30 ... 295	■	■	-	-	-	■	-	-	-	80	
	ESNU														
Single-acting	Basic design	8, 10, 12, 16, 20, 25	1 ... 50	24 ... 270	■	-	-	■	-	-	-	■	-	82	
	MA – Plain end cap, axial connection				■	-	-	■	-	-	-	■	-	esnu	
	ESNU – Round cylinder with piston Ø 32 ... 63														
	91														
	ESN														
Basic design	8, 10, 12, 16, 20, 25	1 ... 50	24 ... 270	24 ... 270	■	-	-	-	-	-	-	-	-	83	

Product options

P	Elastic cushioning rings/pads at both ends	MQ	Alternative plain end cap, lateral connection	Q	With protection against rotation	K3	Female piston rod thread
PPV	Pneumatic cushioning, adjustable at both ends	MA	Alternative plain end cap, axial connection	S2	Through piston rod	K5	Special piston rod thread
PPS	Pneumatic cushioning, self-adjusting at both ends	MH	Alternative end cap, direct mounting	KP	With clamping unit	K6	Shortened male piston rod thread
A	Position sensing			K8	Extended piston rod	S10	Slow speed
				S6	Heat-resistant seals up to max. 120 °C	S11	Low friction
				K2	Extended male piston rod thread	R3	High corrosion protection

Standard cylinders DSNU, to ISO 6432

1 Technical data – Double-acting

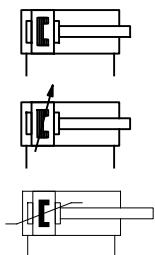

Technical data		Dimensions → 88						
Piston Ø		8	10	12	16	20	25	
Pneumatic connection		M5	M5	M5	M5	G1/8	G1/8	
End of piston rod		Male thread						
Piston rod thread		M4	M4	M6	M6	M8	M10x1.25	
Cushioning	P	Elastic cushioning rings/pads at both ends						
	PPV	–			Pneumatic cushioning, adjustable at both ends			
	PPS	–			Pneumatic cushioning, self-adjusting at both ends			
Cushioning length	PPV [mm]	–		9	12	15	17	
	PPS [mm]	–			12	15	17	
Theoretical force at 6 bar, advancing	[N]	30	47	68	121	189	295	
Theoretical force at 6 bar, retracting	[N]	23	40	51	104	158	247	
Max. torque at the piston rod ¹⁾	[Nm]	–	–	0.10	0.10	0.20	0.45	

1) Only applies to variants with protection against rotation Q.

Operating conditions		Basic design, product options		S6	
Piston Ø		8 ... 12		16 ... 25	
Operating pressure	[bar]	1.5 ... 10 ²⁾		1 ... 10	
Ambient temperature ³⁾	[°C]	–20 ... +80		0 ... +120	

2) Piston-Ø 12 mm, PPV – pneumatic cushioning, adjustable at both ends 2 ... 10 bar.

3) Note operating range of proximity sensors.

Materials	
Piston rod	High-alloy stainless steel
Bearing cap	Colourless anodised wrought aluminium alloy
Cylinder barrel	High-alloy stainless steel
End cap	Colourless anodised wrought aluminium alloy
Seals	NBR, TPE-U (PU)

Order code – Double-acting

1

Type		DSNU	-	-	-	-	A	-	-	-	-
DSNU	Double-acting standard cylinder										
Piston Ø [mm]											
	Stroke [mm]										
8, 10	10, 15, 20, 25, 30, 40, 50, 60, 80, 100	1 ... 100									
12	10, 15, 20, 25, 30, 40, 50, 60, 80, 100, 125, 160, 200	1 ... 200									
16	10, 15, 20, 25, 30, 35, 40, 50, 60, 70, 80, 100, 125, 150, 160, 200	1 ... 200									
20	10, 15, 20, 25, 30, 35, 40, 50, 60, 70, 80, 100, 125, 150, 160, 200, 250, 300, 320	1 ... 320									
25	10, 15, 20, 25, 30, 35, 40, 50, 60, 70, 80, 100, 125, 150, 160, 200, 250, 300, 320, 400, 500	1 ... 500									
Cushioning											
P	Elastic cushioning rings/pads at both ends										
PPV	Pneumatic cushioning, adjustable at both ends										1
PPS	Pneumatic cushioning, self-adjusting at both ends										2
Position sensing											
A	Via proximity sensor										3
Alternative end cap											
MQ	Plain end cap, lateral connection										4
Piston rod											
-	Piston rod at one end										
S2	Through piston rod										
Extended piston rod [mm]											
... K8	1 ... 150										5
Temperature resistance											
S6	Heat-resistant seals up to max. 120 °C										6

- 1 Not with piston Ø 8, 10 mm.
- 2 Not with piston Ø 8, 10, 12 mm.
- 3 Minimum stroke: 10 mm.
- 4 Not with piston rod S2.
- 5 Piston Ø 8/10: 1 ... 50 mm.
Piston Ø 12/16: 1 ... 100 mm.
Piston Ø 20: 1 ... 110 mm.
Piston Ø 25: 1 ... 150 mm.
- 6 Not for DSNU-12-...-PPV.

Ordering – Product options

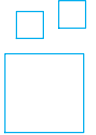

Configurable product

This product and all its options can be ordered using the configurator.

The configurator can be found under Products on the DVD or
[→ www.festo.com/catalogue/...](http://www.festo.com/catalogue/...)

Enter the type code in the search field.

Standard cylinders DSNU, to ISO 6432

1

Order code – Double-acting with protection against rotation

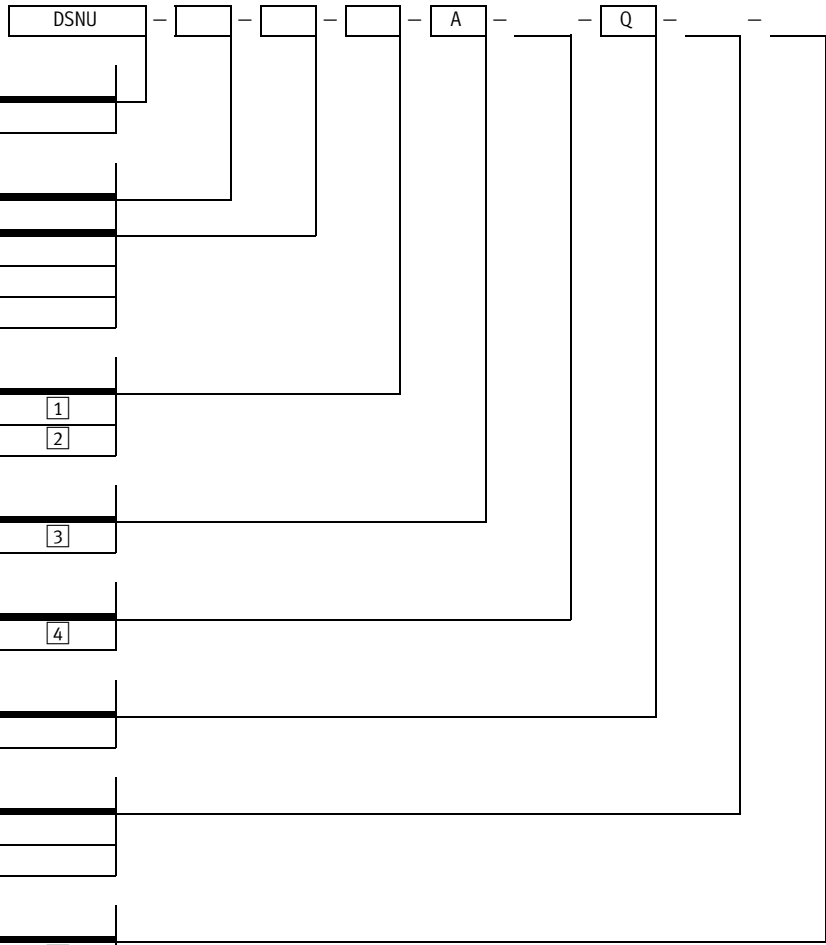

Type	
DSNU	Double-acting standard cylinder

Piston Ø [mm]	
	Stroke [mm]
12, 16	5 ... 160
20	5 ... 200
25	5 ... 250

Cushioning	
P	Elastic cushioning rings/pads at both ends 1
PPV	Pneumatic cushioning, adjustable at both ends 2

Position sensing	
A	Via proximity sensor 3

Alternative end cap	
MQ	Plain end cap, lateral connection 4

Protection against rotation	
Q	Square piston rod

Piston rod	
-	Piston rod at one end
S2	Through piston rod

Extended piston rod [mm]	
... K8	1 ... 150 5

- 1 Only with piston Ø 12 mm.
- 2 Only with piston Ø 16, 20, 25 mm.
- 3 Minimum stroke: 10 mm.
- 4 Not with piston rod S2.
- 5 Piston Ø 12/16: 1 ... 100 mm.
Piston Ø 20: 1 ... 110 mm.
Piston Ø 25: 1 ... 150 mm.

Ordering – Product options

Configurable product

This product and all its options can be ordered using the configurator.

The configurator can be found under Products on the DVD or
[→ www.festo.com/catalogue/...](http://www.festo.com/catalogue/...)

Enter the type code in the search field.

74

→ www.festo.com/catalogue/...

Subject to change – 2013/11

★ Quick ordering

P – Elastic cushioning rings/pads at both ends

Part No.	Type
Piston Ø 12 mm	
19189	DSNU-12-10-P-A
1908255	DSNU-12-15-P-A
1908256	DSNU-12-20-P-A
19190	DSNU-12-25-P-A
1908257	DSNU-12-30-P-A
19191	DSNU-12-40-P-A
19192	DSNU-12-50-P-A
1908258	DSNU-12-60-P-A
19193	DSNU-12-80-P-A
19194	DSNU-12-100-P-A
19195	DSNU-12-125-P-A
19196	DSNU-12-160-P-A
19197	DSNU-12-200-P-A
Piston Ø 16 mm	
19198	DSNU-16-10-P-A
1908259	DSNU-16-15-P-A
1908260	DSNU-16-20-P-A
19199	DSNU-16-25-P-A
1908261	DSNU-16-30-P-A
1908262	DSNU-16-35-P-A
19200	DSNU-16-40-P-A
19201	DSNU-16-50-P-A
1908263	DSNU-16-60-P-A
1908264	DSNU-16-70-P-A
19202	DSNU-16-80-P-A
19203	DSNU-16-100-P-A
19204	DSNU-16-125-P-A
19205	DSNU-16-160-P-A
1908265	DSNU-16-150-P-A
19206	DSNU-16-200-P-A

Part No.	Type
Piston Ø 20 mm	
19207	DSNU-20-10-P-A
1908282	DSNU-20-15-P-A
1908283	DSNU-20-20-P-A
19208	DSNU-20-25-P-A
1908284	DSNU-20-30-P-A
1908285	DSNU-20-35-P-A
19209	DSNU-20-40-P-A
19210	DSNU-20-50-P-A
1908286	DSNU-20-60-P-A
1908287	DSNU-20-70-P-A
19211	DSNU-20-80-P-A
19212	DSNU-20-100-P-A
19213	DSNU-20-125-P-A
1908311	DSNU-25-150-P-A
19214	DSNU-20-160-P-A
19215	DSNU-20-200-P-A
19216	DSNU-20-250-P-A
19217	DSNU-20-300-P-A
34718	DSNU-20-320-P-A

Part No.	Type
Piston Ø 25 mm	
19218	DSNU-25-10-P-A
1908305	DSNU-25-15-P-A
1908306	DSNU-25-20-P-A
19219	DSNU-25-25-P-A
1908307	DSNU-25-30-P-A
1908308	DSNU-25-35-P-A
19220	DSNU-25-40-P-A
19221	DSNU-25-50-P-A
1908309	DSNU-25-60-P-A
1908310	DSNU-25-70-P-A
19222	DSNU-25-80-P-A
19223	DSNU-25-100-P-A
19224	DSNU-25-125-P-A
1908288	DSNU-20-150-P-A
19225	DSNU-25-160-P-A
19226	DSNU-25-200-P-A
19227	DSNU-25-250-P-A
19228	DSNU-25-300-P-A
34719	DSNU-25-320-P-A

Standard cylinders DSNU, to ISO 6432

★ Quick ordering

1

PPV – Pneumatic cushioning, adjustable at both ends

Part No.	Type
Piston Ø 16 mm	
1908266	DSNU-16-10-PPV-A
1908267	DSNU-16-15-PPV-A
1908268	DSNU-16-20-PPV-A
33973	DSNU-16-25-PPV-A
1908269	DSNU-16-30-PPV-A
1908270	DSNU-16-35-PPV-A
19229	DSNU-16-40-PPV-A
19230	DSNU-16-50-PPV-A
1908271	DSNU-16-60-PPV-A
1908272	DSNU-16-70-PPV-A
19231	DSNU-16-80-PPV-A
19232	DSNU-16-100-PPV-A
19233	DSNU-16-125-PPV-A
1908273	DSNU-16-150-PPV-A
19234	DSNU-16-160-PPV-A
19235	DSNU-16-200-PPV-A

Part No.	Type
Piston Ø 20 mm	
1908289	DSNU-20-10-PPV-A
1908290	DSNU-20-15-PPV-A
1908291	DSNU-20-20-PPV-A
33974	DSNU-20-25-PPV-A
1908292	DSNU-20-30-PPV-A
1908293	DSNU-20-35-PPV-A
19236	DSNU-20-40-PPV-A
19237	DSNU-20-50-PPV-A
1908294	DSNU-20-60-PPV-A
1908295	DSNU-20-70-PPV-A
19238	DSNU-20-80-PPV-A
19239	DSNU-20-100-PPV-A
19240	DSNU-20-125-PPV-A
1908296	DSNU-20-150-PPV-A
19241	DSNU-20-160-PPV-A
19242	DSNU-20-200-PPV-A
19243	DSNU-20-250-PPV-A
19244	DSNU-20-300-PPV-A
34720	DSNU-20-320-PPV-A

Part No.	Type
Piston Ø 25 mm	
1908312	DSNU-25-10-PPV-A
1908313	DSNU-25-15-PPV-A
1908314	DSNU-25-20-PPV-A
33975	DSNU-25-25-PPV-A
1908315	DSNU-25-30-PPV-A
1908316	DSNU-25-35-PPV-A
19245	DSNU-25-40-PPV-A
19246	DSNU-25-50-PPV-A
1908317	DSNU-25-60-PPV-A
1908318	DSNU-25-70-PPV-A
19247	DSNU-25-80-PPV-A
19248	DSNU-25-100-PPV-A
19249	DSNU-25-125-PPV-A
1908319	DSNU-25-150-PPV-A
19250	DSNU-25-160-PPV-A
19251	DSNU-25-200-PPV-A
19252	DSNU-25-250-PPV-A
19253	DSNU-25-300-PPV-A
34721	DSNU-25-320-PPV-A

PPS – Pneumatic cushioning, self-adjusting at both ends

Part No.	Type
Piston Ø 16 mm	
1908274	DSNU-16-10-PPS-A
1908275	DSNU-16-15-PPS-A
1908276	DSNU-16-20-PPS-A
559263	DSNU-16-25-PPS-A
1908277	DSNU-16-30-PPS-A
1908278	DSNU-16-35-PPS-A
559264	DSNU-16-40-PPS-A
559265	DSNU-16-50-PPS-A
1908279	DSNU-16-60-PPS-A
1908280	DSNU-16-70-PPS-A
559266	DSNU-16-80-PPS-A
559267	DSNU-16-100-PPS-A
559268	DSNU-16-125-PPS-A
1908281	DSNU-16-150-PPS-A
559269	DSNU-16-160-PPS-A
559270	DSNU-16-200-PPS-A

Part No.	Type
Piston Ø 20 mm	
1908297	DSNU-20-10-PPS-A
1908298	DSNU-20-15-PPS-A
1908299	DSNU-20-20-PPS-A
559271	DSNU-20-25-PPS-A
1908300	DSNU-20-30-PPS-A
1908301	DSNU-20-35-PPS-A
559272	DSNU-20-40-PPS-A
559273	DSNU-20-50-PPS-A
1908302	DSNU-20-60-PPS-A
1908303	DSNU-20-70-PPS-A
559274	DSNU-20-80-PPS-A
559275	DSNU-20-100-PPS-A
559276	DSNU-20-125-PPS-A
1908304	DSNU-20-150-PPS-A
559277	DSNU-20-160-PPS-A
559278	DSNU-20-200-PPS-A
559279	DSNU-20-250-PPS-A
559280	DSNU-20-300-PPS-A
559281	DSNU-20-320-PPS-A

Part No.	Type
Piston Ø 25 mm	
1908320	DSNU-25-10-PPS-A
1908321	DSNU-25-15-PPS-A
1908322	DSNU-25-20-PPS-A
559282	DSNU-25-25-PPS-A
1908323	DSNU-25-30-PPS-A
1908324	DSNU-25-35-PPS-A
559283	DSNU-25-40-PPS-A
559284	DSNU-25-50-PPS-A
1908325	DSNU-25-60-PPS-A
1908326	DSNU-25-70-PPS-A
559285	DSNU-25-80-PPS-A
559286	DSNU-25-100-PPS-A
559287	DSNU-25-125-PPS-A
1908327	DSNU-25-150-PPS-A
559288	DSNU-25-160-PPS-A
559289	DSNU-25-200-PPS-A
559290	DSNU-25-250-PPS-A
559291	DSNU-25-300-PPS-A
559292	DSNU-25-320-PPS-A

Technical data – Double-acting

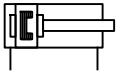

1

Technical data		Dimensions → 90		
Piston Ø		16	20	25
Pneumatic connection		M5	G $\frac{1}{8}$	G $\frac{1}{8}$
End of piston rod		Male thread		
Piston rod thread		M6	M8	M10x1.25
Cushioning		Elastic cushioning rings/pads at both ends		
Theoretical force at 6 bar, advancing	[N]	121	189	295
Theoretical force at 6 bar, retracting	[N]	104	158	247

Operating conditions	
Operating pressure	[bar] 1 ... 8
Ambient temperature ¹⁾	[°C] -10 ... +60

1) Note operating range of proximity sensors.

Materials	
Piston rod	High-alloy steel
Bearing cap	PA reinforced
Cylinder barrel	Anodised wrought aluminium alloy
End cap	PA reinforced
Seals	NBR, TPE-U (PU)

Order code – Double-acting

		DSNUP	-		-		-	P	-	A
Type										
DSNUP	Double-acting standard cylinder									
Piston Ø [mm]										
	Stroke [mm]									
16, 20, 25	25, 50, 100									
Cushioning										
P	Elastic cushioning rings/pads at both ends									
Position sensing										
A	Via proximity sensor									

Ordering – Product options

Configurable product

This product and all its options can be ordered using the configurator.

The configurator can be found under Products on the DVD or
[→ www.festo.com/catalogue/...](http://www.festo.com/catalogue/...)

Enter the type code in the search field.

Standard cylinders DSNU-...-KP, with clamping unit

FESTO

1 Technical data – Double-acting with clamping unit

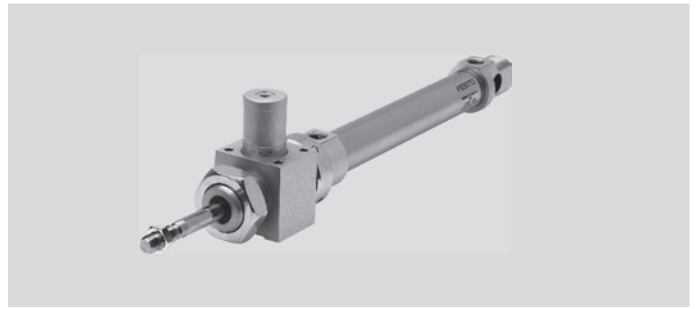
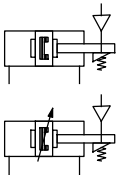

Technical data		Dimensions → 89						
Piston Ø		8	10	12	16	20	25	
Pneumatic connection		M5	M5	M5	M5	G $\frac{1}{8}$	G $\frac{1}{8}$	
Release connection		M5	M5	M5	M5	M5	M5	
End of piston rod		Male thread						
Piston rod thread		M4	M4	M6	M6	M8	M10x1.25	
Cushioning	P	Elastic cushioning rings/pads at both ends						
	PPV	-			Pneumatic cushioning, adjustable at both ends			
	PPS	-			Pneumatic cushioning, self-adjusting at both ends			
Cushioning length	PPV [mm]	-		9	12	15	17	
	PPS [mm]	-			12	15	17	
Theoretical force at 6 bar, advancing	[N]	30	47	68	121	189	295	
Theoretical force at 6 bar, retracting	[N]	23	40	51	104	158	247	
Holding force of the clamping unit	[N]	80	80	180	180	350	350	
Max. axial backlash with clamped piston rod without load	[mm]	0.2	0.2	0.3	0.3	0.3	0.5	

Operating conditions

Operating pressure	[bar]	3 ... 10
Ambient temperature ¹⁾	[°C]	-10 ... +80

1) Note operating range of proximity sensors.

Materials

Piston rod	High-alloy stainless steel
Bearing cap	Colourless anodised wrought aluminium alloy
Cylinder barrel	High-alloy stainless steel
End cap	Colourless anodised wrought aluminium alloy
Seals	NBR, TPE-U (PU)

Order code – Double-acting with clamping unit

1

Type		DSNU	-		-		-		-	A	-		-		-	KP	
DSNU	Double-acting standard cylinder																
Piston Ø [mm]																	
	Stroke [mm]																
8, 10	10, 25, 40, 50, 80, 100	1 ... 100															
12, 16	10, 25, 40, 50, 80, 100, 125, 160, 200	1 ... 200															
20	10, 25, 40, 50, 80, 100, 125, 160, 200, 250, 300, 320	1 ... 320															
25	10, 25, 40, 50, 80, 100, 125, 160, 200, 250, 300, 320, 400, 500	1 ... 500															
Cushioning																	
P	Elastic cushioning rings/pads at both ends																
PPV	Pneumatic cushioning, adjustable at both ends																1
PPS	Pneumatic cushioning, self-adjusting at both ends																2
Position sensing																	
A	Via proximity sensor																3
Alternative end cap																	
MQ	Plain end cap, lateral connection																4
Piston rod																	
-	Single-ended piston rod																
S2	Through piston rod																
Clamping unit																	
KP	Attached																
Temperature resistance																	
S6	Heat-resistant seals up to max. 120 °C																

1 Not with piston Ø 8 and 10 mm.

2 Not with piston Ø 8, 10, 12 mm.

3 Minimum stroke: 10 mm.

4 Not with piston rod S2.

Ordering – Product options

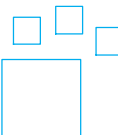

Configurable product

This product and all its options can be ordered using the configurator.

The configurator can be found under Products on the DVD or

→ www.festo.com/catalogue/...

Enter the type code in the search field.

Standard cylinders DSN, to ISO 6432

1 Technical data – Double-acting

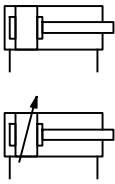

Technical data			Dimensions → 88					
Piston Ø			8	10	12	16	20	25
Pneumatic connection			M5	M5	M5	M5	G1/8	G1/8
End of piston rod			Male thread					
Piston rod thread			M4	M4	M6	M6	M8	M10x1.25
Cushioning	P		Elastic cushioning rings/pads at both ends					
	PPV		–			Pneumatic cushioning, adjustable at both ends		
Cushioning length	PPV	[mm]	–			14	17	17
Theoretical force at 6 bar, advancing		[N]	30	47	68	121	189	295
Theoretical force at 6 bar, retracting		[N]	23	40	51	104	158	247

Operating conditions			Dimensions → 88					
Piston Ø			8	10	12	16	20	25
Operating pressure	[bar]		1.5 ... 10			1 ... 10		
Ambient temperature	[°C]		–20 ... +80					

Materials	
Piston rod	High-alloy stainless steel
Bearing cap	Colourless anodised wrought aluminium alloy
Cylinder barrel	High-alloy stainless steel
End cap	Colourless anodised wrought aluminium alloy
Seals	NBR, TPE-U (PU)

Order code – Double-acting

DSN	–		–		–		–	
-----	---	--	---	--	---	--	---	--

Type	Double-acting standard cylinder
DSN	

Piston Ø [mm]	Stroke [mm]	
8, 10	10, 25, 40, 50, 80, 100	1 ... 100
12, 16	10, 25, 40, 50, 80, 100, 125, 160, 200	1 ... 200
20	10, 25, 40, 50, 80, 100, 125, 160, 200, 250, 300, 320	1 ... 320
25	10, 25, 40, 50, 80, 100, 125, 160, 200, 250, 300, 320, 400, 500	1 ... 500

Cushioning	
P	Elastic cushioning rings/pads at both ends
PPV	Pneumatic cushioning, adjustable at both ends ¹

¹ Not with piston Ø 8, 10, 12.

Ordering – Product options

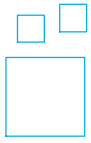

Configurable
product

This product and all its options can
be ordered using the configurator.

The configurator can be found under
Products on the DVD or

→ www.festo.com/catalogue/...

Enter the type code in the search field.

1

★ Quick ordering

P – Elastic cushioning rings/pads at both ends

Part No.	Type
Piston Ø 12 mm	
5047	DSN-12-10-P
5048	DSN-12-25-P
5049	DSN-12-40-P
5050	DSN-12-50-P
5051	DSN-12-80-P
5052	DSN-12-100-P
8519	DSN-12-125-P
5053	DSN-12-160-P
5054	DSN-12-200-P
Piston Ø 16 mm	
5056	DSN-16-10-P
5057	DSN-16-25-P
5058	DSN-16-40-P
5059	DSN-16-50-P
5060	DSN-16-80-P
5061	DSN-16-100-P
8520	DSN-16-125-P
5062	DSN-16-160-P
5063	DSN-16-200-P

Part No.	Type
Piston Ø 20 mm	
5065	DSN-20-10-P
5066	DSN-20-25-P
5067	DSN-20-40-P
5068	DSN-20-50-P
5069	DSN-20-80-P
5070	DSN-20-100-P
8521	DSN-20-125-P
5071	DSN-20-160-P
5072	DSN-20-200-P
8522	DSN-20-250-P
5073	DSN-20-300-P
34710	DSN-20-320-P

Part No.	Type
Piston Ø 25 mm	
5075	DSN-25-10-P
5076	DSN-25-25-P
5077	DSN-25-40-P
5078	DSN-25-50-P
5079	DSN-25-80-P
5080	DSN-25-100-P
8523	DSN-25-125-P
5081	DSN-25-160-P
5082	DSN-25-200-P
8524	DSN-25-250-P
5083	DSN-25-300-P
34711	DSN-25-320-P

Standard cylinders ESNU, to ISO 6432

1 Technical data – Single-acting



Technical data		Dimensions → 88					
Piston Ø		8	10	12	16	20	25
Pneumatic connection		M5	M5	M5	M5	G1/8	G1/8
End of piston rod		Male thread					
Piston rod thread		M4	M4	M6	M6	M8	M10x1.25
Cushioning		Elastic cushioning rings/pads at both ends					
Theoretical force at 6 bar, advancing	[N]	24	41	61	107	169	270
Theoretical spring return force	10 mm stroke [N]	4.9	4.9	6.3	13.2	18.3	22.9
	25 mm stroke [N]	4.1	4.1	5.4	11.9	16.5	21.2
	50 mm stroke [N]	2.8	4.8	3.9	9.8	13.6	18.5

Operating conditions		Dimensions → 88					
Piston Ø		8	10	12	16	20	25
Operating pressure	[bar]	1.5 ... 10			1.2 ... 10		
Ambient temperature ¹⁾	[°C]	-20 ... +80					

1) Note operating range of proximity sensors.

Materials	
Piston rod	High-alloy stainless steel
Bearing cap	Colourless anodised wrought aluminium alloy
Cylinder barrel	High-alloy stainless steel
End cap	Colourless anodised wrought aluminium alloy
Seals	NBR, TPE-U (PU)

Order code – Single acting

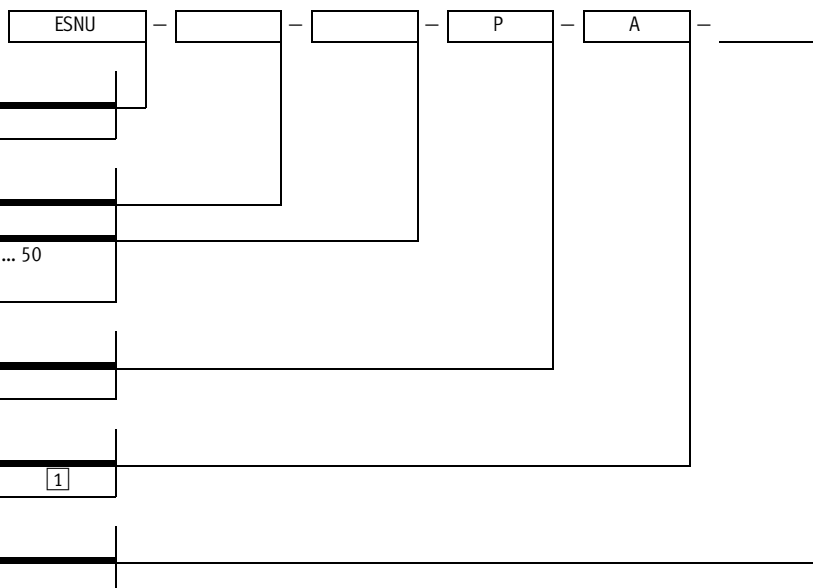

1) Minimum stroke: 10 mm.

Technical data – Single-acting

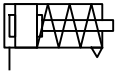

Technical data		Dimensions → 88					
Piston Ø		8	10	12	16	20	25
Pneumatic connection		M5	M5	M5	M5	G $\frac{1}{8}$	G $\frac{1}{8}$
End of piston rod		Male thread					
Piston rod thread		M4	M4	M6	M6	M8	M10x1.25
Cushioning		Elastic cushioning rings/pads at both ends					
Theoretical force at 6 bar, advancing	[N]	24	41	61	107	169	270
Theoretical spring return force	10 mm stroke [N]	4.9	4.9	6.3	13.2	18.3	22.9
	25 mm stroke [N]	4.1	4.1	5.4	11.9	16.5	21.2
	50 mm stroke [N]	2.8	4.8	3.9	9.8	13.6	18.5

Operating conditions		Dimensions → 88					
Piston Ø		8	10	12	16	20	25
Operating pressure	[bar]	1.5 ... 10			1.2 ... 10		
Ambient temperature	[°C]	-20 ... +80					

Materials	
Piston rod	High-alloy stainless steel
Bearing cap	Colourless anodised wrought aluminium alloy
Cylinder barrel	High-alloy stainless steel
End cap	Colourless anodised wrought aluminium alloy
Seals	NBR, TPE-U (PU)
Spring	Spring steel

Order code – Single acting

ESN		–		–		–	
Type							
ESN	Single-acting standard cylinder						
Piston Ø [mm]							
	Stroke [mm]						
8, 10, 12, 16, 20, 25	10, 25, 50	1 ... 50					
Cushioning							
P	Elastic cushioning rings/pads at both ends						

Ordering – Product options

Configurable product

This product and all its options can be ordered using the configurator.

The configurator can be found under Products on the DVD or
[→ www.festo.com/catalogue/...](http://www.festo.com/catalogue/...)

Enter the type code in the search field.

Standard cylinders DSNU/DSNUP/DSN/ESNU/ESN, to ISO 6432

Accessories

1

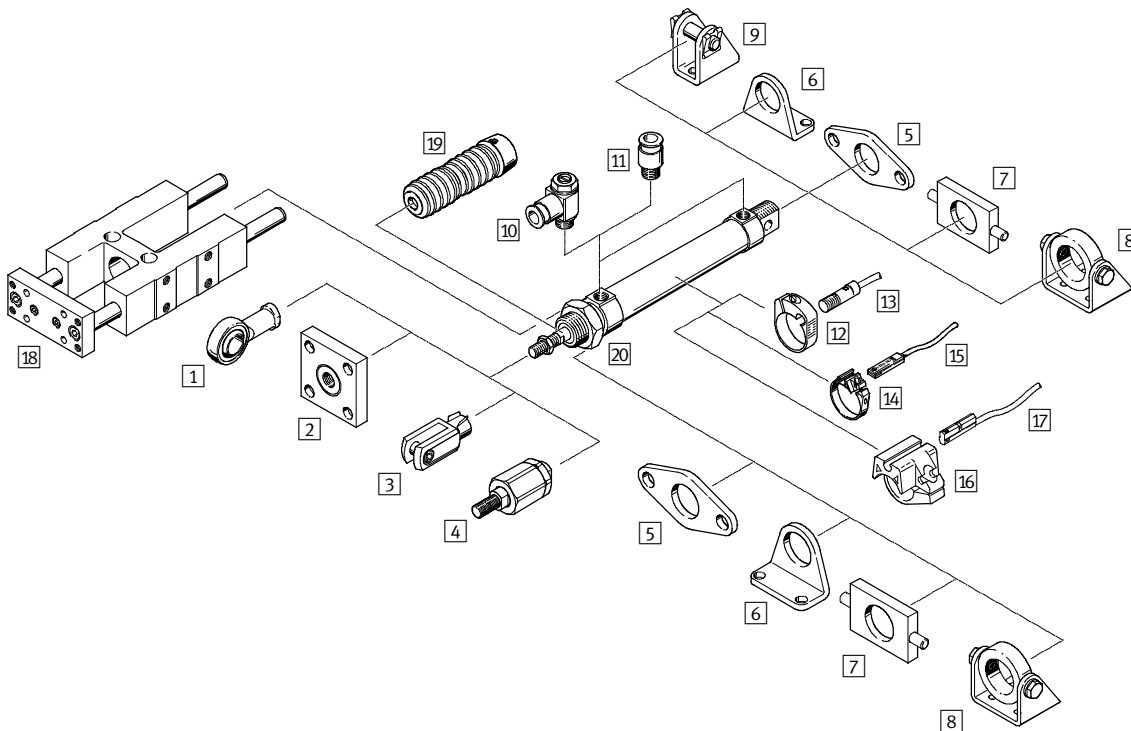









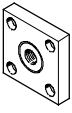
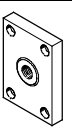

		DSNU/ESNU					DSNUP	DSN/ESN	→ Page/online
		MQ	Q	S2	KP				
1	Rod eye SGS Rod eye CRSGS	■	■	■	■	■	■	■	85 dsnu
2	Coupling piece KSG/KSZ	■	■	■	■	■	■	■	85
3	Rod clevis SG Rod clevis CRSG	■	■	■	■	■	■	■	85 dsnu
4	Self-aligning rod coupler FK	■	■	■	■	■	■	■	85
5	Flange mounting FBN Flange mounting CRFBN	■	■	■	■	■	■	■	85 dsnu
6	Foot mounting HBN Foot mounting CRHBN	■	■	■	■	■	■	■	85 dsnu
7	Swivel mounting WBN	■	■	■	■	■	■	■	85
8	Swivel mounting SBN	■	■	■	■	-	■	■	85
9	Clevis foot LBN Clevis foot CRLBN	■	-	■	-	■	■	■	85 dsnu
10	One-way flow control valve GRLA/GRLZ ¹⁾ One-way flow control valve CRGRLA ¹⁾	■	■	■	■	■	■	■	85 dsnu
11	Push-in fitting QS	■	■	■	■	■	■	■	908
12	Mounting kit SMBR Mounting kit CRSMBR	■	■	■	■	-	-	-	85 dsnu
13	Proximity sensor SMEO/SMT0-4 Proximity sensor CRSMEO-4	■	■	■	■	-	-	-	86 dsnu
14	Mounting kit SMBR-8	■	■	■	■	■	-	-	85
15	Proximity sensor SME/SMT-8	■	■	■	■	■	-	-	86
16	Mounting kit SMBR-10	■	■	■	■	-	-	-	85
17	Proximity sensor SME/SMT-10	■	■	■	■	-	-	-	86
18	Guide unit FEN	■	■	-	■	-	■	■	87
19	Protective bellows kit DADB	■	■	-	■	-	-	-	dsnu
20	Hex nut MSK	■	■	■	■	-	■	■	87

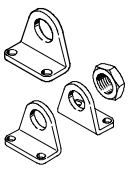
1) Only push-in fittings or one-way flow control valves with cylindrical connecting thread (M or G thread) should be used for the supply ports in combination with DSNUP.

Standard cylinders DSNU/DSNUP/DSN/ESNU/ESN, to ISO 6432

Accessories – Ordering data

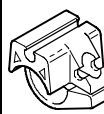
	For Ø	Part No.	Type
1 Rod eye Technical data online: → sgs			
	8, 10	9253	SGS-M4
	12, 16	★ 9254	SGS-M6
	20	★ 9255	SGS-M8
	25	★ 9261	SGS-M10x1,25
2 Coupling piece Technical data online: → ksg			
	25	32963	KSG-M10x1,25
2 Coupling piece Technical data online: → ksz			
	12, 16	36123	KSZ-M6
	20	36124	KSZ-M8
	25	36125	KSZ-M10x1,25
3 Rod clevis Technical data online: → sg			
	8, 10	6532	SG-M4
	12, 16	★ 3110	SG-M6
	20	★ 3111	SG-M8
	25	★ 6144	SG-M10x1,25
4 Self-aligning rod coupler Technical data online: → fk			
	8, 10	6528	FK-M4
	12, 16	★ 2061	FK-M6
	20	★ 2062	FK-M8
	25	★ 6140	FK-M10x1,25
5 Flange mounting Dimensions online: → dsnu			
	8, 10	5129	FBN-8/10
	12, 16	5130	FBN-12/16
	20, 25	5131	FBN-20/25
6 Foot mounting Dimensions online: → dsnu			
	8, 10	5123	HBN-8/10x1
		5124	HBN-8/10x2
	12, 16	★ 5125	HBN-12/16x1
		★ 5126	HBN-12/16x2
	20, 25	★ 5127	HBN-20/25x1
		★ 5128	HBN-20/25x2



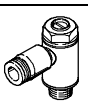
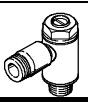





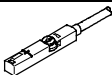
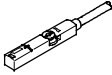
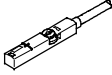

	For Ø	Part No.	Type
7 Swivel mounting Dimensions online: → dsnu			
	8, 10	8608	WBN-8/10x1
	12, 16	8609	WBN-12/16
	20, 25	8610	WBN-20/25
8 Swivel mounting Dimensions online: → dsnu			
	20, 25	539927	SBN-20/25
9 Clevis foot Technical data online: → lbn			
	8, 10	6057	LBN-8/10
	12, 16	★ 6058	LBN-12/16
	20, 25	★ 6059	LBN-20/25
12/14/16 Mounting kit for proximity sensor			
	8	★ 175091	SMBR-8-8
	10	★ 175092	SMBR-8-10
	12	★ 175093	SMBR-8-12
	16	★ 175094	SMBR-8-16
	20	★ 175095	SMBR-8-20
	25	★ 175096	SMBR-8-25
SMT/SME-10			
	8	175101	SMBR-10-8
	10	173227	SMBR-10-10
	12	175102	SMBR-10-12
	16	173228	SMBR-10-16
	20	175103	SMBR-10-20
	25	175104	SMBR-10-25
Round design SMTO/SMEO-4			
	8	19272	SMBR-8
	10	19273	SMBR-10
	12	19274	SMBR-12
	16	19275	SMBR-16
	20	19276	SMBR-20
	25	19277	SMBR-25

Function	For Ø	Connection		Part No.	Type
		Thread	O.D.		
10 One-way flow control valve with slotted head screw, metal¹⁾ for exhaust air flow control Technical data → 611					
	12, 16	M5	3	★ 193137	GRLA-M5-QS-3-D
	20, 25	G½	4	★ 193143	GRLA-1/8-QS-4-D
For supply air flow control Technical data → 611					
	12, 16	M5	3	★ 193153	GRLZ-M5-QS-3-D
	20, 25	G½	4	★ 193157	GRLZ-1/8-QS-4-D



1) The recommended flow control valves are based on a tubing length to the valve of 1 m. For deviations of ±50%, flow control valves with a bigger or smaller flow rate must be selected to guarantee the optimum flow control function and cylinder speed.

Accessories – Ordering data

1

	Description	Part No.	Type
13 Proximity sensor, round design, magneto-resistive – N/O contact			
	PNP, cable	152836	SMT0-4U-PS-K-LED-24
	PNP, plug	152742	SMT0-4U-PS-S-LED-24
	NPN, cable	152837	SMT0-4U-NS-K-LED-24
	NPN, plug	152743	SMT0-4U-NS-S-LED-24
Magnetic reed – N/O contact			
	Cable	36198	SME0-4U-K-LED-24
	Cable	175401	SME0-4U-K5-LED-24
	Plug	151526	SME0-4U-S-LED-24-B
15 Proximity sensor for T-slot, magneto-resistive – N/O contact Technical data → 737			
	PNP, cable	★ 574335	SMT-8M-A-PS-24V-E-2,5-OE
	PNP, plug	★ 574334	SMT-8M-A-PS-24V-E-0,3-M8D
	PNP, plug	★ 574337	SMT-8M-A-PS-24V-E-0,3-M12
	NPN, cable	★ 574338	SMT-8M-A-NS-24V-E-2,5-OE
	NPN, plug	★ 574339	SMT-8M-A-NS-24V-E-0,3-M8D
Magneto-resistive – N/C contact Technical data → 737			
	PNP, cable	★ 574340	SMT-8M-A-PO-24V-E-7,5-OE
Magnetic reed – N/O contact Technical data → 732			
	Cable	★ 543862	SME-8M-DS-24V-K-2,5-OE
	Cable	★ 543863	SME-8M-DS-24V-K-5,0-OE
	Cable	★ 543872	SME-8M-ZS-24V-K-2,5-OE
	Plug	★ 543861	SME-8M-DS-24V-K-0,3-M8D
Technical data → 734			
	Cable	★ 150855	SME-8-K-LED-24
	Plug	150857	SME-8-S-LED-24
Magnetic reed – N/C contact Technical data → 734			
	Cable	160251	SME-8-O-K-LED-24
17 Proximity sensor for C-slot, magneto-resistive – N/O contact Technical data → 749			
	PNP, cable	★ 551373	SMT-10M-PS-24V-E-2,5-L-OE
	PNP, plug	★ 551375	SMT-10M-PS-24V-E-0,3-L-M8D
Magnetic reed – N/O contact Technical data → 749			
	Plug	★ 551367	SME-10M-DS-24V-E-0,3-L-M8D
	Cable	★ 551365	SME-10M-DS-24V-E-2,5-L-OE
	Cable	★ 551369	SME-10M-ZS-24V-E-2,5-L-OE
13/15/17 Connecting cable, straight socket Technical data → 949			
	2.5 m	★ 541333	NEBU-M8G3-K-2.5-LE3
	5 m	★ 541334	NEBU-M8G3-K-5-LE3
	2.5 m	541363	NEBU-M12G5-K-2.5-LE3
	5 m	541364	NEBU-M12G5-K-5-LE3
Angled socket Technical data → 949			
	2.5 m	★ 541338	NEBU-M8W3-K-2.5-LE3
	5 m	★ 541341	NEBU-M8W3-K-5-LE3
	2.5 m	541367	NEBU-M12W5-K-2.5-LE3
	5 m	541370	NEBU-M12W5-K-5-LE3

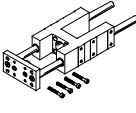
Accessories – Ordering data

	For Ø	Stroke	Part No.	Type	
18	Guide unit for variable strokes				
	With recirculating ball bearing guide			Technical data online: → fen	
	8, 10	1 ... 100	35197	FEN-8/10-...-KF	
	12, 16	1 ... 200	33481	FEN-12/16-...-KF	
	20	2 ... 250	33482	FEN-20-...-KF	
	25	2 ... 250	33483	FEN-25-...-KF	
	With plain-bearing guide			Technical data online: → fen	
	8, 10	1 ... 100	35196	FEN-8/10-...	
	12, 16	1 ... 200	19168	FEN-12/16-...	
	20	2 ... 250	19169	FEN-20-...	
	25	2 ... 250	19170	FEN-25-...	
20	Hex nut				
	16		★ 189007	MSK-M16X1,5	
	20, 25		★ 189009	MSK-M22X1,5	

Standard cylinders DSNU/DSNUP/DSN/ESNU/ESN, to ISO 6432

Dimensions

1 Basic design

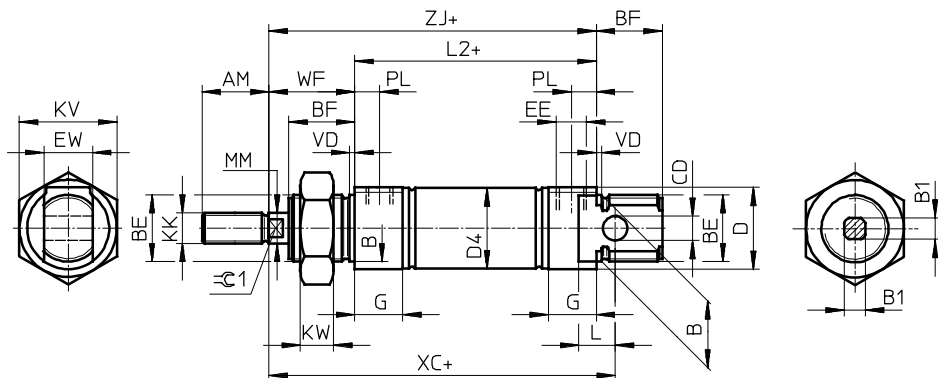

Note
Piston rod nut is not included in the scope of delivery with $\varnothing 8 \dots 20$.

MQ – Lateral air connection

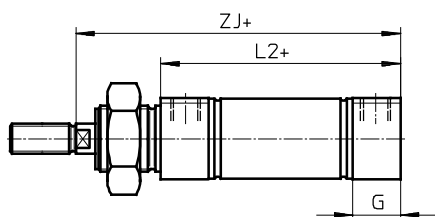

S2 – Through piston rod

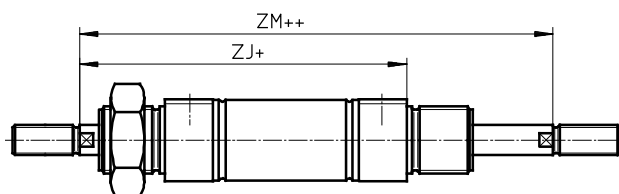

Note
The thread types at both piston rod ends are identical. In combination with variant Q, the left-hand piston rod end is square, the right-hand piston rod end round.

K8 – Extended piston rod

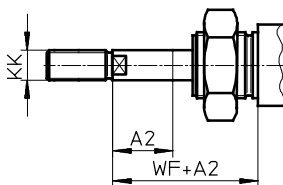

Note
If variant K8 is required in combination with S2, the piston rod will only be extended on one side.

+ = plus stroke length
++ = plus 2x stroke length

\varnothing [mm]	A2 max.	AM	B \varnothing h9	B1 \square	BE	BF	CD \varnothing H9	D \varnothing	D4 \varnothing	EE	EW	G	KK
8	50	12	12	-	M12x1.25	12	4	15	9.3	M5	8	10	M4
10				11.3									
12	100	16	16	5.5	M16x1.5	17	6	20	13.3	G $\frac{1}{8}$	12	16	M6
16				17.3									
20	110	20	22	7	M22x1.5	20	8	27	21.3	G $\frac{1}{8}$	16	16	M8
25	150	22		9		22			26.5				M10x1.25

\varnothing [mm]	KV	KW	L	L2	MM \varnothing	PL	VD	WF	XC ± 1	ZM	ZJ	$\approx \text{C1}$
8	19	6	6	46	4	6	2	16	64	78.4	62	-
10				50								
12	24	8	9	56	6	8.2	22	75	82	100	72	5
16				56								
20	32	11	12	68	8	8.2	24	95	104	116	92	7
25				68				28				

Standard cylinders DSNU/DSNUP/DSN/ESNU/ESN, to ISO 6432

Dimensions

1 DSNUP...

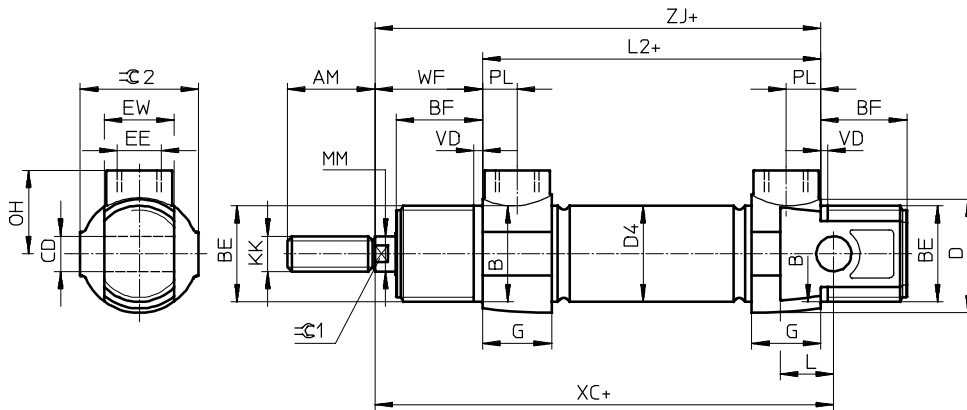

Note
 Only push-in fittings or one-way flow control valves with cylindrical connecting thread (M or G thread) should be used for the supply ports. Piston rod nut is not included in the scope of delivery with Ø 16/20.

+ = plus stroke length

Ø	AM	B	BE	BF	CD	D	D4	EE
[mm]		Ø h9			Ø H9	Ø	Ø	
16	16	16	M16x1.5	17	6	20	18	M5
20	20	22	M22x1.5	20	8	27	22	G $\frac{1}{8}$
25	22	22	M22x1.5	22	8	27	27	G $\frac{1}{8}$

Ø	EW	G	KK	L	L2	MM	OH	PL	VD
[mm]						Ø			
16	12	10	M6	8	56	6	14	4.9	2
20	16	16	M8	12	68	8	19	7.9	2
25	16	16	M10x1.25	12	70	10	19	7.9	2

Ø	WF	XC	ZJ	Ø 1	Ø 2	Max. tightening torque of thread	
						BE ¹⁾	EE
[mm]		±1					
16	22	82	78	5	19	12/8	1.5
20	24	95	92	7	27	22/15	10
25	28	104	98	9	27	22/15	10

1) Bearing cap/end cap.



- For the highest requirements for running characteristics, service life and load carrying ability
- Universal use thanks to individual variants
- Comprehensive range of accessories
- Selected types in accordance with the ATEX Directive for explosive atmospheres → www.festo.com/catalogue/ex

→ www.festo.com/catalogue/dsnu

Product range overview

Type/function	Version	Piston Ø [mm]	Stroke [mm]	Force [N]	Product options										→ Page/ online
					P	PPV	PPS	A	Q	S2	KP	K8	S6		
Double-acting	DSNU														
	Basic design	32, 40, 50, 63	1 ... 500	483 ... 1,870	■	■	■	■	■	■	■	■	■	■	92
	MQ – Plain end cap, lateral connection				■	■	■	■	■	-	■	■	■		
	MA – Plain end cap, axial connection				■	-	-	■	■	-	■	■	■	dsnu	
	MH – Direct mounting				■	■	-	■	■	-	-	■	■		
DSNU – Standard cylinder with piston Ø 8 ... 25													71		
Single-acting	ESNU														
	Basic design	32, 40, 50, 63	1 ... 50	442 ... 1,763	■	-	-	■	-	-	-	■	-	97	
	MA – Plain end cap, axial connection				■	-	-	■	-	-	-	■	-	esnu	
	ESNU – Standard cylinder with piston Ø 8 ... 25													71	

Product options

P	Elastic cushioning rings/pads at both ends	MQ	Alternative plain end cap, lateral connection	S2	Through piston rod	K3	Female piston rod thread
PPV	Pneumatic cushioning, adjustable at both ends	MA	Alternative plain end cap, axial connection	KP	With clamping unit	K5	Special piston rod thread
PPS	Pneumatic cushioning, self-adjusting at both ends	MH	Alternative end cap, direct mounting	K8	Extended piston rod	K6	Shortened male piston rod thread
A	Position sensing	Q	With protection against rotation	S6	Heat-resistant seals up to max. 120 °C	S10	Slow speed
				K2	Extended male piston rod thread	S11	Low friction
						R3	High corrosion protection
						R8	Wiper seal

Round cylinders DSNU

1 Technical data – Double-acting

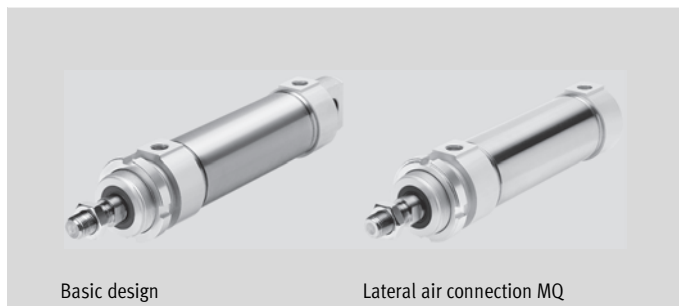
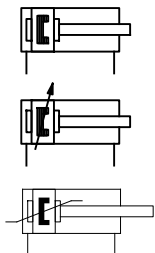

Technical data		Dimensions → 102			
Piston Ø		32	40	50	63
Pneumatic connection		G1/8	G1/4	G1/4	G3/8
End of piston rod		Male thread			
Piston rod thread		M10x1.25	M12x1.25	M16x1.5	M16x1.5
Cushioning	P	Elastic cushioning rings/pads at both ends			
	PPV	Pneumatic cushioning, adjustable at both ends			
	PPS	Pneumatic cushioning, self-adjusting at both ends			
Cushioning length	PPV [mm]	14	18	20	21
	PPS [mm]	14	18	20	21
Theoretical force at 6 bar, advancing	[N]	483	753	1,178	1,870
Theoretical force at 6 bar, retracting	[N]	415	633	990	1,682
Max. torque at the piston rod ¹⁾	[Nm]	0.8	1.1	1.5	1.5

1) Only applies to variants with protection against rotation Q.

Operating conditions		Basic design, product options		S6
Operating pressure	[bar]	1 ... 10		
Ambient temperature ²⁾	[°C]	-20 ... +80		0 ... +120

2) Note operating range of proximity sensors.

Materials	
Piston rod	High-alloy steel
Bearing cap	Wrought aluminium alloy
Cylinder barrel	High-alloy stainless steel
End cap	Wrought aluminium alloy
Seals	NBR, TPE-U (PU)

Order code – Double-acting

		DSNU	-		-		-		-	A	-		-		-		-		
Type																			
DSNU	Double-acting round cylinder																		
Piston Ø [mm]																			
	Stroke [mm]																		
32, 40, 50, 63	25, 40, 50, 80, 100, 125, 160, 200, 250, 320	1 ... 500																	
Cushioning																			
P	Elastic cushioning rings/pads at both ends																		
PPV	Pneumatic cushioning, adjustable at both ends																		
PPS	Pneumatic cushioning, self-adjusting at both ends																		
Position sensing																			
A	Via proximity sensor																1		
Alternative end cap																			
MQ	Plain end cap, lateral connection																2		
Piston rod																			
-	Piston rod at one end																		
S2	Through piston rod																		
Extended piston rod [mm]																			
... K8	1 ... 500																		
Temperature resistance																			
S6	Heat-resistant seals up to max. 120 °C																		

1 Minimum stroke: 10 mm.

2 Not with piston rod S2.

Ordering – Product options

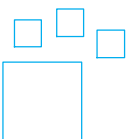

Configurable product

This product and all its options can be ordered using the configurator.

The configurator can be found under Products on the DVD or

→ www.festo.com/catalogue/...

Enter the type code in the search field.

Round cylinders DSNU

1

Order code – Double-acting with protection against rotation

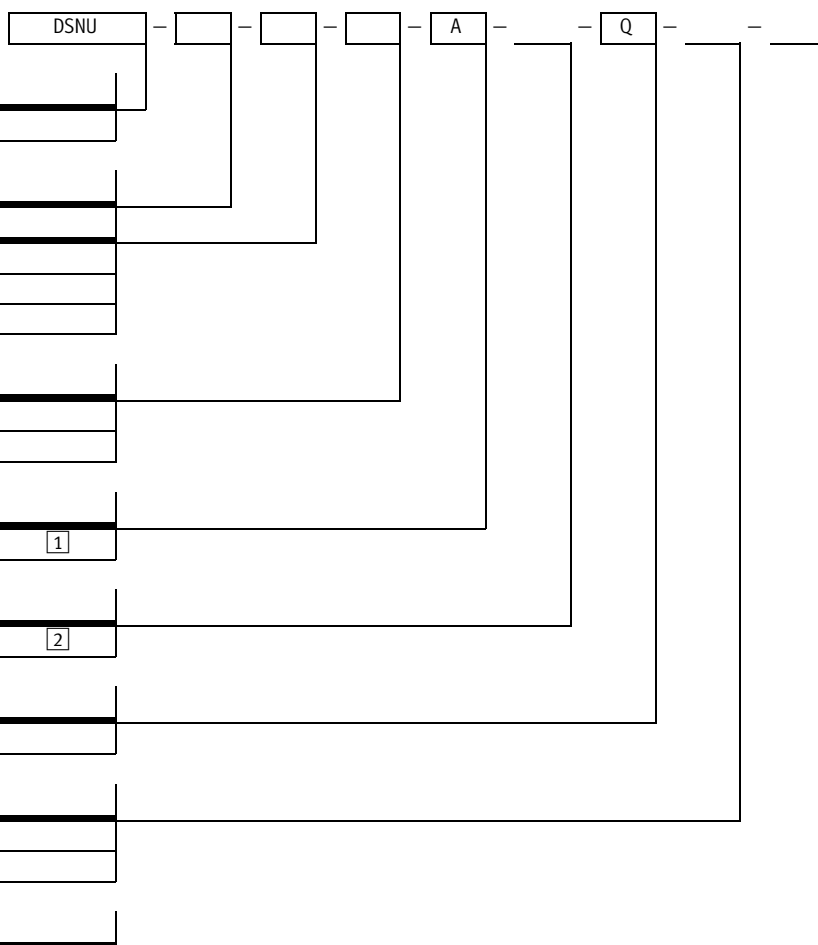

Type	
DSNU	Double-acting round cylinder
Piston Ø [mm]	
	Stroke [mm]
32	5 ... 300
40, 50	5 ... 400
63	5 ... 500
Cushioning	
P	Elastic cushioning rings/pads at both ends
PPV	Pneumatic cushioning, adjustable at both ends
Position sensing	
A	Via proximity sensor 1
Alternative end cap	
MQ	Plain end cap, lateral connection 2
Protection against rotation	
Q	Square piston rod
Piston rod	
-	Piston rod at one end
S2	Through piston rod
Extended piston rod [mm]	
... K8	1 ... 500

- 1 Minimum stroke: 10 mm.
- 2 Not with piston rod S2.

Ordering – Product options



Configurable product

This product and all its options can be ordered using the configurator.

The configurator can be found under Products on the DVD or
[→ www.festo.com/catalogue/...](http://www.festo.com/catalogue/...)

Enter the type code in the search field.

Technical data – Double-acting with clamping unit

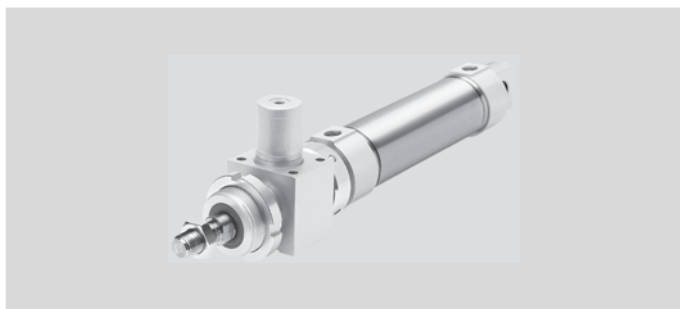
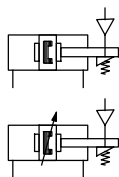

1

Technical data		Dimensions → 103			
Piston Ø		32	40	50	63
Pneumatic connection		G1/8	G1/4	G1/4	G3/8
Release connection		M5	G1/8	G1/8	G1/8
End of piston rod		Male thread			
Piston rod thread		M10x1.25	M12x1.25	M16x1.5	M16x1.5
Cushioning	P	Elastic cushioning rings/pads at both ends			
	PPV	Pneumatic cushioning, adjustable at both ends			
	PPS	Pneumatic cushioning, self-adjusting at both ends			
Cushioning length	PPV [mm]	14	18	20	21
	PPS [mm]	14	18	20	21
Theoretical force at 6 bar, advancing	[N]	483	753	1,178	1,870
Theoretical force at 6 bar, retracting	[N]	415	633	990	1,682
Holding force of the clamping unit	[N]	600	1,000	1,400	2,000
Max. axial backlash with clamped piston rod without load	[mm]	0.5	0.5	0.7	0.7

Operating conditions	
Operating pressure	[bar] 3 ... 10
Ambient temperature ¹⁾	[°C] -10 ... +80

1) Note operating range of proximity sensors.

Materials	
Piston rod	High-alloy steel
Bearing cap	Wrought aluminium alloy
Cylinder barrel	High-alloy stainless steel
End cap	Wrought aluminium alloy
Seals	NBR, TPE-U (PU)

Round cylinders DSNU-...-KP, with clamping unit

1

Order code – Double-acting with clamping unit

		DSNU	-		-		-		-	A	-		-		-	KP	-		
Type																			
DSNU	Double-acting round cylinder																		
Piston Ø [mm]																			
	Stroke [mm]																		
32, 40, 50, 63	25, 40, 50, 80, 100, 125, 160, 200, 250, 320	1 ... 500																	
Cushioning																			
P	Elastic cushioning rings/pads at both ends																		
PPV	Pneumatic cushioning, adjustable at both ends																		
PPS	Pneumatic cushioning, self-adjusting at both ends																		
Position sensing																			
A	Via proximity sensor																	1	
Alternative cylinder end cap																			
MQ	Plain end cap, lateral connection																	2	
Piston rod type																			
-	Single-ended piston rod																		
S2	Through piston rod																		
Clamping unit																			
KP	Attached																		
Temperature resistance																			
S6	Heat-resistant seals up to max. 120 °C																		

- 1 Minimum stroke: 10 mm.
- 2 Not with piston rod type S2.

Ordering – Product options

	<p>Configurable product</p>	<p>This product and all its options can be ordered using the configurator.</p>	<p>The configurator can be found under Products on the DVD or → www.festo.com/catalogue/...</p>	<p>Enter the type code in the search field.</p>
---	------------------------------------	---	---	---

Technical data – Single-acting

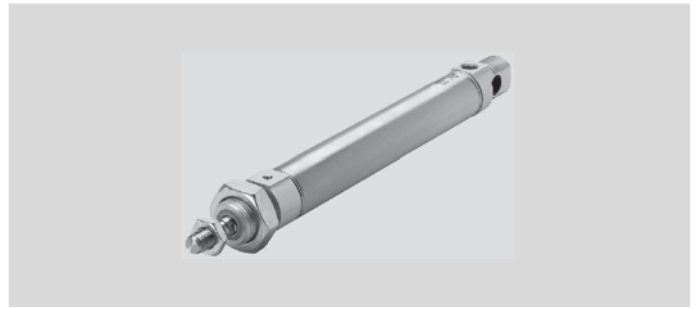

1

Technical data		Dimensions → 102			
Piston Ø		32	40	50	63
Pneumatic connection		G $\frac{1}{8}$	G $\frac{1}{4}$	G $\frac{1}{4}$	G $\frac{3}{8}$
End of piston rod		Male thread			
Piston rod thread		M10x1.25	M12x1.25	M16x1.5	M16x1.5
Cushioning		Elastic cushioning rings/pads at both ends			
Theoretical force at 6 bar, advancing	[N]	442	688	1,071	1,763
Max. spring return force	10 mm stroke [N]	36	60	95	95
Max. spring return force	25 mm stroke [N]	30	50	82	82
Max. spring return force	50 mm stroke [N]	20	30	60	60

Operating conditions

Operating pressure	[bar]	1.2 ... 10
Ambient temperature ¹⁾	[°C]	-20 ... +80

1) Note operating range of proximity sensors.

Materials

Piston rod	High-alloy steel
Bearing cap	Wrought aluminium alloy
Cylinder barrel	High-alloy stainless steel
End cap	Wrought aluminium alloy
Seals	NBR, TPE-U (PU)

Order code – Single acting

ESNU		-		-		-	P	-	A	-	
Type											
ESNU	Single-acting round cylinder										
Piston Ø [mm]											
	Stroke [mm]										
32, 40, 50, 63	10, 25, 50	1 ... 50									
Cushioning											
P	Elastic cushioning rings/pads at both ends										
Position sensing											
A	Via proximity sensor 1										
Extended piston rod [mm]											
... K8	1 ... 50										

1 Minimum stroke: 10 mm.

Round cylinders DSNU/ESNU

Ordering – Product options

1



Configurable product

This product and all its options can be ordered using the configurator.

The configurator can be found under Products on the DVD or
www.festo.com/catalogue/...

Enter the type code in the search field.

Accessories

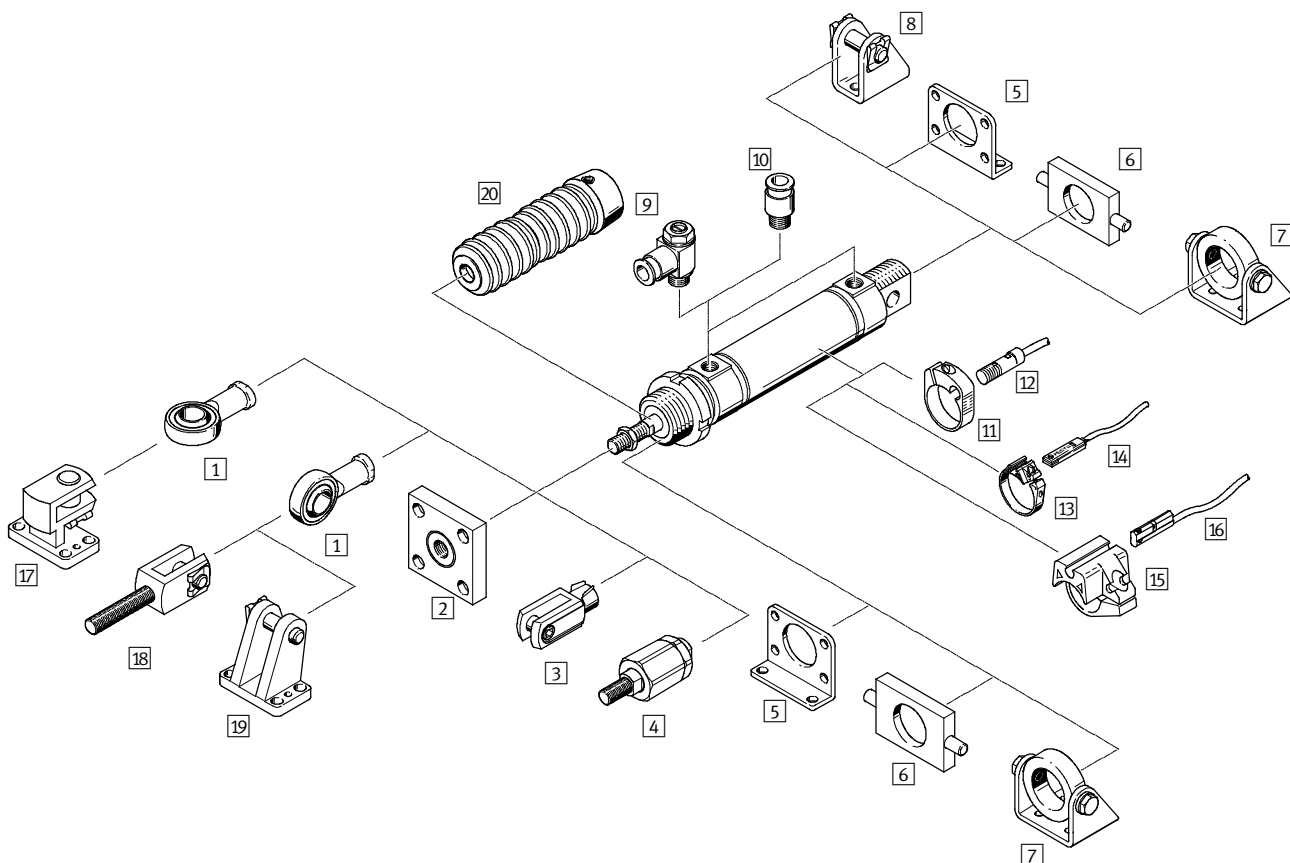





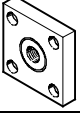
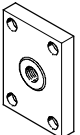

	DSNU/ESNU	DSNU-				→ Page/ online
		MQ	Q	S2	KP	
1 Rod eye SGS	■	■	■	■	■	99
Rod eye CRSGS	■	■	■	■	■	dsnu
2 Coupling piece KSG/KSZ	■	■	■	■	■	99
3 Rod clevis SG	■	■	■	■	■	99
Rod clevis CRSG	■	■	■	■	■	dsnu
4 Self-aligning rod coupler FK	■	■	■	■	■	99
5 Flange mounting FBN	■	■	■	■	■	99
Flange mounting CRFV	■	■	■	■	■	dsnu
Foot mounting HBN	■	■	■	■	–	99
Foot mounting CRH	■	■	■	■	–	dsnu
6 Swivel mounting WBN	■	■	■	■	■	99
7 Swivel mounting SBN	■	■	■	■	■	99

Accessories

	DSNU/ESNU	DSNU-				→ Page/ online	
		MQ	Q	S2	KP		
8	Clevis foot LBN	■	–	■	–	■	99
	Clevis foot CRLBN	■	–	■	–	■	dsnu
9	One-way flow control valve GRLA/GRLZ	■	■	■	■	■	100
	One-way flow control valve CRGRLA	■	■	■	■	■	dsnu
10	Push-in fitting QS	■	■	■	■	■	908
11	Mounting kit CRSMBR	■	■	■	■	■	100
12	Proximity sensor SMEO/SMT0-4	■	■	■	■	■	100
	Proximity sensor CRSME0-4	■	■	■	■	■	dsnu
13	Mounting kit SMBR-8	■	■	■	■	■	100
14	Proximity sensor SME/SMT-8	■	■	■	■	■	100
15	Mounting kit SMBR-10	■	■	■	■	■	100
16	Proximity sensor SME/SMT-10	■	■	■	■	■	101
17	Right-angle clevis foot LQG	■	■	■	■	■	101
18	Rod clevis SGA	■	■	■	■	■	101
19	Clevis foot LBG	■	■	■	■	■	101
20	Protective bellows kit DADB	■	■	–	■	–	dsnu

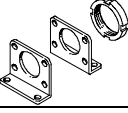
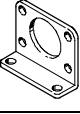
Accessories – Ordering data



	For Ø	Part No.	Type
1 Rod eye			Technical data online: → sgs
	32	★ 9261	SGS-M10x1,25
	40	★ 9262	SGS-M12x1,25
	50, 63	★ 9263	SGS-M16x1,5
2 Coupling piece			Technical data online: → ksg
	32	32963	KSG-M10x1,25
	40	32964	KSG-M12x1,25
	50, 63	32965	KSG-M16x1,5
2 Coupling piece			Technical data online: → ksz
	32	36125	KSZ-M10x1,25
	40	36126	KSZ-M12x1,25
	50, 63	36127	KSZ-M16x1,5
3 Rod clevis			Technical data online: → sg
	32	★ 6144	SG-M10x1,25
	40	★ 6145	SG-M12x1,25
	50, 63	★ 6146	SG-M16x1,5
4 Self-aligning rod coupler			Technical data online: → fk
	32	★ 6140	FK-M10x1,25
	40	★ 6141	FK-M12x1,25
	50, 63	★ 6142	FK-M16x1,5

	For Ø	Part No.	Type
5 Foot mounting			Dimensions online: → dsnu
	32	195851	HBN-32x2
	40	195852	HBN-40x2
	50	195853	HBN-50x2
	63	195854	HBN-63x2
5 Flange mounting			Dimensions online: → dsnu
	32	195855	FBN-32
	40	195856	FBN-40
	50	195857	FBN-50
	63	195858	FBN-63
6 Swivel mounting			Dimensions online: → dsnu
	32	195863	WBN-32
	40	195864	WBN-40
	50, 63	195865	WBN-50/63
7 Swivel mounting			Dimensions online: → dsnu
	32	539924	SBN-32
	40	539925	SBN-40
	50, 63	539926	SBN-50/63
8 Clevis foot			Technical data online: → lbn
	32	195860	LBN-32
	40	195861	LBN-40
	50, 63	195862	LBN-50/63





Round cylinders DSNU/ESNU

Accessories – Ordering data



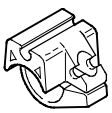

1

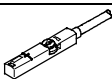
	For Ø	Connection		Part No.	Type
		Thread	O.D.		
9 One-way flow control valve with slotted head screw, metal¹⁾					
for exhaust air flow control Technical data → 611					
	32	G1/8	6	★ 193144	GRLA-1/8-QS-6-D
	40	G1/4	6	★ 193146	GRLA-1/4-QS-6-D
	50		8	★ 193147	GRLA-1/4-QS-8-D
	63	G3/8	8	★ 193150	GRLA-3/8-QS-8-D
For supply air flow control Technical data → 611					
	32	G1/8	6	★ 193158	GRLZ-1/8-QS-6-D

1) The recommended flow control valves are based on a tubing length to the valve of 1 m. For deviations of ±50%, flow control valves with a bigger or smaller flow rate must be selected to guarantee the optimum flow control function and cylinder speed.

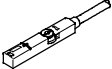
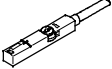
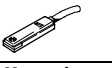
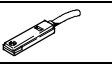
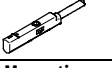
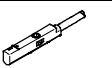
	For Ø	Part No.	Type
11/13/15 Mounting kit for proximity sensor, round design SMTO/SMEO-4			
	32	163888	CRSMBR-32
	40	163889	CRSMBR-40
	50	163890	CRSMBR-50
	63	163891	CRSMBR-63
SMT/SME-8			
	32	★ 175097	SMBR-8-32
	40	★ 175098	SMBR-8-40
	50	★ 175099	SMBR-8-50
	63	★ 175100	SMBR-8-63
SMT/SME-10			
	32	175105	SMBR-10-32
	40	175106	SMBR-10-40
	50	175107	SMBR-10-50
	63	175108	SMBR-10-63
12 Proximity sensor, round design, magneto-resistive – N/O contact			
	PNP, cable	152836	SMTO-4U-PS-K-LED-24
	PNP, plug	152742	SMTO-4U-PS-S-LED-24
	NPN, cable	152837	SMTO-4U-NS-K-LED-24
	NPN, plug	152743	SMTO-4U-NS-S-LED-24
Magnetic reed – N/O contact			
	Cable	36198	SMEO-4U-K-LED-24
	Cable	175401	SMEO-4U-K5-LED-24
	Plug	151526	SMEO-4U-S-LED-24-B
14 Proximity sensor for T-slot, magneto-resistive – N/O contact Technical data → 737			
	PNP, cable	★ 574335	SMT-8M-A-PS-24V-E-2,5-OE
	PNP, plug	★ 574334	SMT-8M-A-PS-24V-E-0,3-M8D
	PNP, plug	★ 574337	SMT-8M-A-PS-24V-E-0,3-M12
	NPN, cable	★ 574338	SMT-8M-A-NS-24V-E-2,5-OE
	NPN, plug	★ 574339	SMT-8M-A-NS-24V-E-0,3-M8D

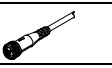
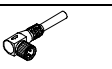
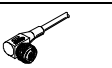
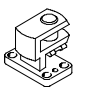
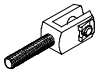
Accessories – Ordering data

	For Ø		Part No.	Type	
14 Proximity sensor for T-slot, magnetic reed – N/C contact					Technical data → 732
	PNP, cable	★	574340	SMT-8M-A-PO-24V-E-7,5-OE	
Magnetic reed – N/O contact					Technical data → 732
	Cable	★	543862	SME-8M-DS-24V-K-2,5-OE	
	Cable	★	543863	SME-8M-DS-24V-K-5,0-OE	
	Cable	★	543872	SME-8M-ZS-24V-K-2,5-OE	
	Plug	★	543861	SME-8M-DS-24V-K-0,3-M8D	
					Technical data → 734
	Cable	★	150855	SME-8-K-LED-24	
	Plug		150857	SME-8-S-LED-24	
Magnetic reed – N/C contact					Technical data → 734
	Cable		160251	SME-8-O-K-LED-24	
16 Proximity sensor for C-slot, magneto-resistive – N/O contact					Technical data → 749
	PNP, cable	★	551373	SMT-10M-PS-24V-E-2,5-L-OE	
	PNP, plug	★	551375	SMT-10M-PS-24V-E-0,3-L-M8D	
Magnetic reed – N/O contact					Technical data → 745
	Plug	★	551367	SME-10M-DS-24V-E-0,3-L-M8D	
	Cable	★	551365	SME-10M-DS-24V-E-2,5-L-OE	
	Cable	★	551369	SME-10M-ZS-24V-E-2,5-L-OE	
12/14/16 Connecting cable, straight socket					Technical data → 949
	2.5 m	★	541333	NEBU-M8G3-K-2.5-LE3	
	5 m	★	541334	NEBU-M8G3-K-5-LE3	
	2.5 m		541363	NEBU-M12G5-K-2.5-LE3	
	5 m		541364	NEBU-M12G5-K-5-LE3	
Angled socket					Technical data → 949
	2.5 m	★	541338	NEBU-M8W3-K-2.5-LE3	
	5 m	★	541341	NEBU-M8W3-K-5-LE3	
	2.5 m		541367	NEBU-M12W5-K-2.5-LE3	
	5 m		541370	NEBU-M12W5-K-5-LE3	
17 Right-angle clevis foot					Technical data online: → lqg
	32		31768	LQG-32	
	40		31769	LQG-40	
	50		31770	LQG-50	
	63		31771	LQG-63	
18 Rod clevis					Technical data online: → sga
	32		32954	SGA-M10x1,25	
	40		10767	SGA-M12x1,25	
	50, 63		10768	SGA-M16x1,5	
19 Clevis foot					Technical data online: → lbg
	32		31761	LBG-32	
	40		31762	LBG-40	
	50		31763	LBG-50	
	63		31764	LBG-63	

Round cylinders DSNU/ESNU

Download CAD data → www.festo.com

1 Basic design

Dimensions

Q – Square piston rod

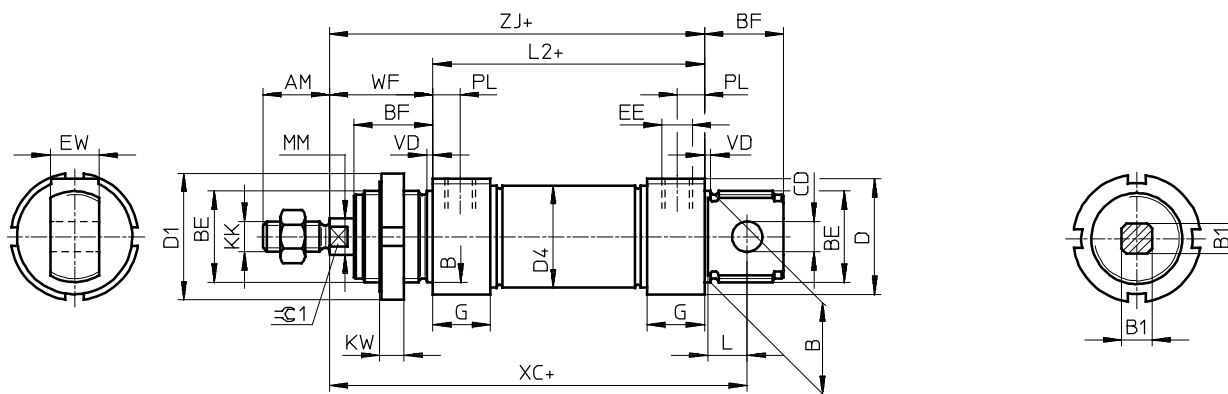

MQ – Lateral supply port

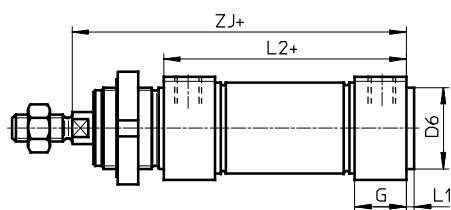

S2 – Through piston rod

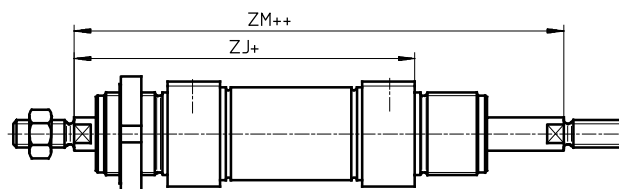

Note

The thread types at both piston rod ends are identical. In combination with variant Q, the left-hand piston rod end is square, the right-hand piston rod end is round.

+ = plus stroke length
++ = plus 2x stroke length

∅	AM	B	B1	BE	BF	CD	D	D1	D4	EE	EW	G
[mm]		∅ h9	□			∅ E10	∅	∅	∅			
32	22	30	10	M30x1.5	26	10	38	42	33.6	G ¹ / ₈	16	19
40	24	38	12	M38x1.5	30	12	46	50	41.6	G ¹ / ₄	18	25
50	32	45	16	M45x1.5	33	16	57	60	52.4	G ³ / ₈	21	28
63							70		65.4			

∅	KK	KW	L	L2	MM	PL	VD	WF	XC	ZJ	ZM	≈C1
[mm]					∅				±1			
32	M10x1.25	8	13	69.5	12	9	2	34	117.5	103.5	137.5	10
40	M12x1.25		15	84.6	16			12	39	139.6	123.6	162.6
50	M16x1.5	10	16	86.2	20	13	3	44	147.2	130.2	174.2	17
63				94.2				45	156.2	139.2	184.2	

Dimensions

Basic design KP – With clamping unit

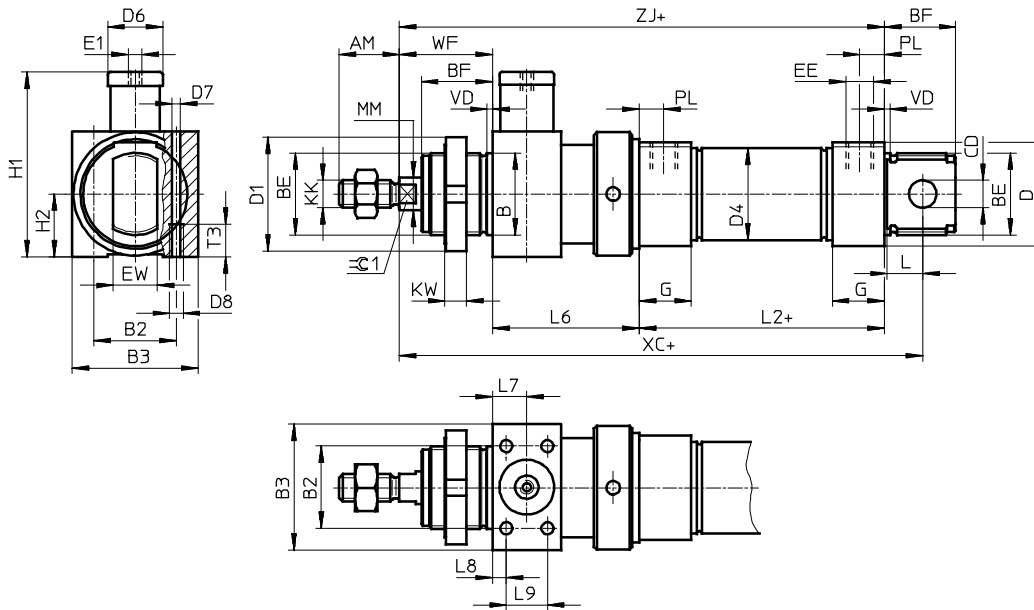

S2 – Through piston rod

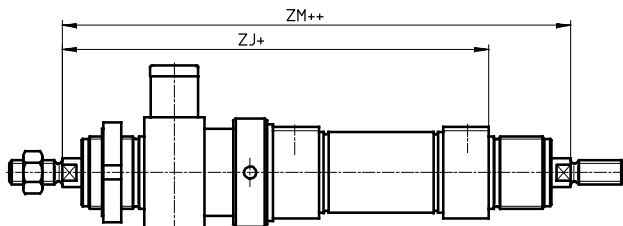

Note

The thread types at both piston rod ends are identical. The clamping unit is mounted on only one side. In combination with variant Q, the right-hand piston rod is square, the left-hand piston rod round. The clamping unit is mounted on the left-hand, round piston rod.

+ = plus stroke length
++ = plus 2x stroke length

∅	AM	B	B2	B3	BE	BF	CD	D	D1	D4	D6	D7	D8	E1	EE	EW	G	H1
[mm]		∅ h9					∅ E10	∅	∅	∅								
32	22	30	30	46	M30x1.5	26	10	38	42	33.6	20	4.4	M5	M5	G ¹ / ₈	16	19	67.5
40	24	38	36	56	M38x1.5	30	12	46	50	41.6	24	6.8	M8	G ¹ / ₈	G ¹ / ₄	18	25	89
50	32	45	50	65	M45x1.5	33	16	57	60	52.4	30	8.5	M10	G ¹ / ₈		21		28
63			54	72	M45x1.5			70						65.4	38		121.5	

∅	H2	KK	KW	MM	L	L2	L6	L7	L8	L9	T3	PL	VD	WF	XC	ZJ	ZM	≈C1
[mm]				∅			±0.75								±1			
32	23	M10x1.25	8	12	13	69.5	55	12.5	5	15	12	9	2	34.5	173	159	191	10
40	28	M12x1.25	10	16	15	84.6	69	17	7	20	18	12	3	40.5	210.1	194.1	230.1	13
50	32.5	M16x1.5		20	16	86.2	78	20						26	20	45.5	226.7	209.7
63	36			20	16	94.2	86	24	8	32	21	46.5		243.7	226.7	268.7		

Compact cylinders ADN/AEN, to ISO 21287

1

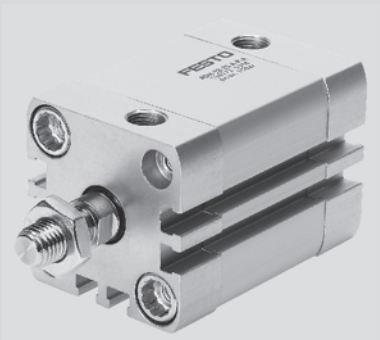

- Compact cylinders with standard dimensions
- More than the standard: Ø 12 to 125 mm
- Innovative technology for maximum speeds
- Flexible in use thanks to customisable variants
- Spare parts service
- Selected types in accordance with the ATEX Directive for explosive atmospheres → www.festo.com/catalogue/ex
- ★ Quick ordering of basic designs → 107

→ www.festo.com/catalogue/adn

Product range overview

Type/function	Piston Ø [mm]	Stroke [mm]	Force [N]	Product options										→ Page/online
				A	I	P	PPS	A	Q	S2	S6	TT		
Double-acting	ADN – Basic design													
	12, 16, 20, 25, 32, 40, 50, 63, 80, 100, 125	1 ... 500	68 ... 7,363	■	■	■	■	■	■	■	■	■	■	105
	ADN- ... -KP – With clamping unit													
Single-acting	20, 25, 32, 40, 50, 63, 80, 100	10 ... 500	20 ... 100	■	■	■	-	■	-	-	-	-	109	
	ADN- ... -EL – With end-position locking													
	20, 25, 32, 40, 50, 63, 80, 100	10 ... 500	20 ... 100	■	■	■	-	■	-	-	-	-	-	adn
Single-acting	AEN – Pushing													
	12, 16, 20, 25, 32, 40, 50, 63, 80, 100	1 ... 25	59 ... 4,510	■	■	■	-	■	-	-	■	-	111	
	AEN-...-Z – Pulling													
Single-acting	12, 16, 20, 25, 32, 40, 50, 63, 80, 100	1 ... 25	59 ... 4,510	■	■	■	-	■	-	-	■	-	aen	
	AEN-...-Q – Protected against rotation with square piston rod													
	16, 20, 25, 32, 40, 50, 63, 80, 100	1 ... 25	59 ... 4,510	■	■	■	-	■	-	-	■	-	111	
Double-acting	ADNP – With polymer end cap													
	20, 25, 32, 40, 50	5 ... 80	141 ... 1,178	■	■	■	-	■	-	-	-	-	adnp	
	ADNH – High-force cylinder													
	25, 40, 63, 100	1 ... 150	542 ... 18,281	■	■	■	-	■	-	-	■	-	adnh	
	ADNM – Multi-position cylinder													
25, 40, 63, 100	1 ... 150	295 ... 4,712	■	■	■	-	■	-	-	■	-	adnm		
ADNGF – Non-rotating with yoke														
12, 16, 20, 25, 32, 40, 50, 63, 80, 100	1 ... 400	68 ... 4,712	-	-	■	■	■	-	■	■	-	-	adngf	

Product options

A	Male thread	Q	Square piston rod	K5	Special piston rod thread	S10	Slow speed
I	Female thread	S1	Reinforced piston rod	K8	Extended piston rod	S11	Low friction
P	Elastic cushioning rings/pads at both ends	S2	Through piston rod	K10	Smooth anodised aluminium piston rod	R3	High corrosion protection
PPS	Pneumatic cushioning, self-adjusting at both ends	S20	Through, hollow piston rod	S6	Heat-resistant seals up to max. 120 °C	R8	Dust protection
A	Position sensing	K2	Extended male piston rod thread			TL	Laser etched rating plate
						TT	Low temperature

Technical data – Double-acting

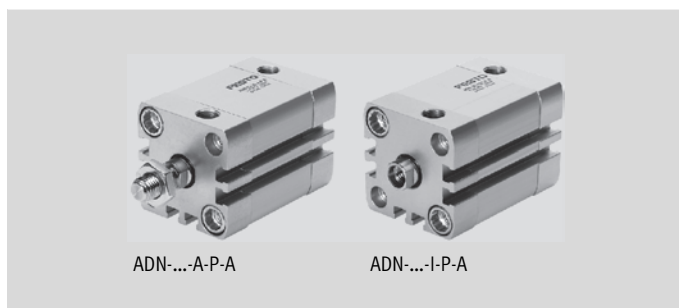
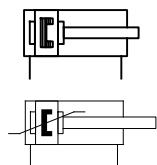

Technical data							Dimensions → 117	
Piston Ø		12	16	20	25	32	40	
Pneumatic connection		M5	M5	M5	M5	G $\frac{1}{8}$	G $\frac{1}{8}$	
Piston rod thread	Female	M3	M4	M6	M6	M8	M8	
	Male	M5	M6	M8	M8	M10x1.25	M10x1.25	
Cushioning	P	Elastic cushioning rings/pads at both ends						
	PPS	–					Pneumatic cushioning, self-adjusting at both ends	
Cushioning length	PPS [mm]	–					4	5
Theoretical force at 6 bar, advancing	[N]	68	121	188	295	483	754	
	S2 [N]	51	90	141	247	415	686	
Theoretical force at 6 bar, retracting	[N]	51	90	141	247	415	686	
	S2 [N]	51	90	141	247	415	686	

Piston Ø		50	63	80	100	125		
Pneumatic connection		G $\frac{1}{8}$	G $\frac{1}{8}$	G $\frac{1}{8}$	G $\frac{1}{8}$	G $\frac{1}{4}$		
Piston rod thread	Female	M10	M10	M12	M12	M16		
	Male	M12x1.25	M12x1.25	M16x1.5	M16x1.5	M20x1.5		
Cushioning	P	Elastic cushioning rings/pads at both ends						
	PPS	Pneumatic cushioning, self-adjusting at both ends					–	
Cushioning length	PPS [mm]	6	7	7.5	–			
Theoretical force at 6 bar, advancing	[N]	1,178	1,870	3,016	4,712	7,363		
	S2 [N]	1,057	1,750	2,827	4,524	7,069		
Theoretical force at 6 bar, retracting	[N]	1,057	1,750	2,827	4,524	7,069		
	S2 [N]	1,057	1,750	2,827	4,524	7,069		

Operating conditions		12	16	20	25	32	40	50	63	80	100	125
Operating pressure	[bar]	1 ... 10		0.6 ... 10								
	PPS [bar]	–				1.5 ... 10		1 ... 10		–		
	Q [bar]	1.3 ... 10		1 ... 10		0.8 ... 10			0.6 ... 10			
	S2 [bar]	1.5 ... 10		1.3 ... 10		1.2 ... 10		1 ... 10		0.8 ... 10		
	TT [bar]	–			1.5 ... 10			1 ... 10			–	
Ambient temperature ¹⁾	[°C]	–20 ... +80										
	S6 [°C]	0 ... +120										
	TT [°C]	–			–40 ... +80						–	

1) Note operating range of proximity sensors.

Materials	
Piston rod	High-alloy steel
Bearing cap	Anodised wrought aluminium alloy
Cylinder barrel	Smooth anodised wrought aluminium alloy
End cap	Anodised wrought aluminium alloy
Seals	TPE-U (PUR)

★ Quick ordering

P – Elastic cushioning rings/pads at both ends

Part No.	Type
Piston Ø 12 mm	
536204	ADN-12-5-A-P-A
536205	ADN-12-10-A-P-A
536206	ADN-12-15-A-P-A
536207	ADN-12-20-A-P-A
536208	ADN-12-25-A-P-A
536209	ADN-12-30-A-P-A
536210	ADN-12-40-A-P-A
536211	ADN-12-5-I-P-A
536212	ADN-12-10-I-P-A
536213	ADN-12-15-I-P-A
536214	ADN-12-20-I-P-A
536215	ADN-12-25-I-P-A
536216	ADN-12-30-I-P-A
536217	ADN-12-40-I-P-A
Piston Ø 16 mm	
536219	ADN-16-5-A-P-A
536220	ADN-16-10-A-P-A
536221	ADN-16-15-A-P-A
536222	ADN-16-20-A-P-A
536223	ADN-16-25-A-P-A
536224	ADN-16-30-A-P-A
536225	ADN-16-40-A-P-A
536331	ADN-16-50-A-P-A
536226	ADN-16-5-I-P-A
536227	ADN-16-10-I-P-A
536228	ADN-16-15-I-P-A
536229	ADN-16-20-I-P-A
536230	ADN-16-25-I-P-A
536231	ADN-16-30-I-P-A
536232	ADN-16-40-I-P-A
536341	ADN-16-50-I-P-A
Piston Ø 20 mm	
536234	ADN-20-5-A-P-A
536235	ADN-20-10-A-P-A
536236	ADN-20-15-A-P-A
536237	ADN-20-20-A-P-A
536238	ADN-20-25-A-P-A
536239	ADN-20-30-A-P-A
536240	ADN-20-40-A-P-A
536241	ADN-20-50-A-P-A
536352	ADN-20-60-A-P-A
536242	ADN-20-5-I-P-A
536243	ADN-20-10-I-P-A
536244	ADN-20-15-I-P-A
536245	ADN-20-20-I-P-A
536246	ADN-20-25-I-P-A
536247	ADN-20-30-I-P-A
536248	ADN-20-40-I-P-A
536249	ADN-20-50-I-P-A
536362	ADN-20-60-I-P-A

Part No.	Type
Piston Ø 25 mm	
536251	ADN-25-5-A-P-A
536252	ADN-25-10-A-P-A
536253	ADN-25-15-A-P-A
536254	ADN-25-20-A-P-A
536255	ADN-25-25-A-P-A
536256	ADN-25-30-A-P-A
536257	ADN-25-40-A-P-A
536258	ADN-25-50-A-P-A
536373	ADN-25-60-A-P-A
536259	ADN-25-5-I-P-A
536260	ADN-25-10-I-P-A
536261	ADN-25-15-I-P-A
536262	ADN-25-20-I-P-A
536263	ADN-25-25-I-P-A
536264	ADN-25-30-I-P-A
536265	ADN-25-40-I-P-A
536366	ADN-25-50-I-P-A
536383	ADN-25-60-I-P-A
Piston Ø 32 mm	
536268	ADN-32-5-A-P-A
536269	ADN-32-10-A-P-A
536270	ADN-32-15-A-P-A
536271	ADN-32-20-A-P-A
536272	ADN-32-25-A-P-A
536273	ADN-32-30-A-P-A
536274	ADN-32-40-A-P-A
536275	ADN-32-50-A-P-A
536276	ADN-32-60-A-P-A
536277	ADN-32-80-A-P-A
536278	ADN-32-5-I-P-A
536279	ADN-32-10-I-P-A
536280	ADN-32-15-I-P-A
536281	ADN-32-20-I-P-A
536282	ADN-32-25-I-P-A
536283	ADN-32-30-I-P-A
536284	ADN-32-40-I-P-A
536285	ADN-32-50-I-P-A
536286	ADN-32-60-I-P-A
536287	ADN-32-80-I-P-A
Piston Ø 40 mm	
536289	ADN-40-5-A-P-A
536290	ADN-40-10-A-P-A
536291	ADN-40-15-A-P-A
536292	ADN-40-20-A-P-A
536293	ADN-40-25-A-P-A
536294	ADN-40-30-A-P-A
536295	ADN-40-40-A-P-A
536296	ADN-40-50-A-P-A
536297	ADN-40-60-A-P-A
536298	ADN-40-80-A-P-A

Part No.	Type
Piston Ø 40 mm	
536299	ADN-40-5-I-P-A
536300	ADN-40-10-I-P-A
536301	ADN-40-15-I-P-A
536302	ADN-40-20-I-P-A
536303	ADN-40-25-I-P-A
536304	ADN-40-30-I-P-A
536305	ADN-40-40-I-P-A
536306	ADN-40-50-I-P-A
536307	ADN-40-60-I-P-A
536308	ADN-40-80-I-P-A
Piston Ø 50 mm	
536310	ADN-50-5-A-P-A
536311	ADN-50-10-A-P-A
536312	ADN-50-15-A-P-A
536313	ADN-50-20-A-P-A
536314	ADN-50-25-A-P-A
536315	ADN-50-30-A-P-A
536316	ADN-50-40-A-P-A
536317	ADN-50-50-A-P-A
536318	ADN-50-60-A-P-A
536319	ADN-50-80-A-P-A
536320	ADN-50-5-I-P-A
536321	ADN-50-10-I-P-A
536322	ADN-50-15-I-P-A
536323	ADN-50-20-I-P-A
536324	ADN-50-25-I-P-A
536325	ADN-50-30-I-P-A
536326	ADN-50-40-I-P-A
536327	ADN-50-50-I-P-A
536328	ADN-50-60-I-P-A
536329	ADN-50-80-I-P-A
Piston Ø 63 mm	
536332	ADN-63-10-A-P-A
536333	ADN-63-15-A-P-A
536334	ADN-63-20-A-P-A
536335	ADN-63-25-A-P-A
536336	ADN-63-30-A-P-A
536337	ADN-63-40-A-P-A
536338	ADN-63-50-A-P-A
536339	ADN-63-60-A-P-A
536340	ADN-63-80-A-P-A
536342	ADN-63-10-I-P-A
536343	ADN-63-15-I-P-A
536344	ADN-63-20-I-P-A
536345	ADN-63-25-I-P-A
536346	ADN-63-30-I-P-A
536347	ADN-63-40-I-P-A
536348	ADN-63-50-I-P-A
536349	ADN-63-60-I-P-A
536350	ADN-63-80-I-P-A

Compact cylinders ADN, to ISO 21287

★ Quick ordering

1 PPS – Pneumatic cushioning, self-adjusting at both ends

Part No.	Type
Piston Ø 32 mm	
572655	ADN-32-10-A-PPS-A
572656	ADN-32-15-A-PPS-A
572657	ADN-32-20-A-PPS-A
572658	ADN-32-25-A-PPS-A
572659	ADN-32-30-A-PPS-A
572660	ADN-32-40-A-PPS-A
572661	ADN-32-50-A-PPS-A
572662	ADN-32-60-A-PPS-A
572663	ADN-32-80-A-PPS-A
572646	ADN-32-10-I-PPS-A
572647	ADN-32-15-I-PPS-A
572648	ADN-32-20-I-PPS-A
572649	ADN-32-25-I-PPS-A
572650	ADN-32-30-I-PPS-A
572651	ADN-32-40-I-PPS-A
572652	ADN-32-50-I-PPS-A
572653	ADN-32-60-I-PPS-A
572654	ADN-32-80-I-PPS-A
Piston Ø 40 mm	
572673	ADN-40-10-A-PPS-A
572674	ADN-40-15-A-PPS-A
572675	ADN-40-20-A-PPS-A
572676	ADN-40-25-A-PPS-A
572677	ADN-40-30-A-PPS-A
572678	ADN-40-40-A-PPS-A
572679	ADN-40-50-A-PPS-A
572680	ADN-40-60-A-PPS-A
572681	ADN-40-80-A-PPS-A
572664	ADN-40-10-I-PPS-A
572665	ADN-40-15-I-PPS-A
572666	ADN-40-20-I-PPS-A
572667	ADN-40-25-I-PPS-A
572668	ADN-40-30-I-PPS-A
572669	ADN-40-40-I-PPS-A
572670	ADN-40-50-I-PPS-A
572671	ADN-40-60-I-PPS-A
572672	ADN-40-80-I-PPS-A

Part No.	Type
Piston Ø 50 mm	
572691	ADN-50-10-A-PPS-A
572692	ADN-50-15-A-PPS-A
572693	ADN-50-20-A-PPS-A
572694	ADN-50-25-A-PPS-A
572695	ADN-50-30-A-PPS-A
572696	ADN-50-40-A-PPS-A
572697	ADN-50-50-A-PPS-A
572698	ADN-50-60-A-PPS-A
572699	ADN-50-80-A-PPS-A
572682	ADN-50-10-I-PPS-A
572683	ADN-50-15-I-PPS-A
572684	ADN-50-20-I-PPS-A
572685	ADN-50-25-I-PPS-A
572686	ADN-50-30-I-PPS-A
572687	ADN-50-40-I-PPS-A
572688	ADN-50-50-I-PPS-A
572689	ADN-50-60-I-PPS-A
572690	ADN-50-80-I-PPS-A

Part No.	Type
Piston Ø 63 mm	
572709	ADN-63-10-A-PPS-A
572710	ADN-63-15-A-PPS-A
572711	ADN-63-20-A-PPS-A
572712	ADN-63-25-A-PPS-A
572713	ADN-63-30-A-PPS-A
572714	ADN-63-40-A-PPS-A
572715	ADN-63-50-A-PPS-A
572716	ADN-63-60-A-PPS-A
572717	ADN-63-80-A-PPS-A
572700	ADN-63-10-I-PPS-A
572701	ADN-63-15-I-PPS-A
572702	ADN-63-20-I-PPS-A
572703	ADN-63-25-I-PPS-A
572704	ADN-63-30-I-PPS-A
572705	ADN-63-40-I-PPS-A
572706	ADN-63-50-I-PPS-A
572707	ADN-63-60-I-PPS-A
572708	ADN-63-80-I-PPS-A

Compact cylinders ADN-...-KP, standard hole pattern, with clamping unit

FESTO

Technical data – Double-acting with clamping unit

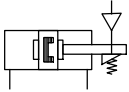

1

Technical data		Dimensions → 120							
Piston Ø		20	25	32	40	50	63	80	100
Pneumatic connection		M5	M5	G $\frac{1}{8}$	G $\frac{1}{8}$	G $\frac{1}{8}$	G $\frac{1}{8}$	G $\frac{1}{8}$	G $\frac{1}{8}$
Release connection		M5	M5	M5	G $\frac{1}{8}$	G $\frac{1}{8}$	G $\frac{1}{8}$	G $\frac{1}{8}$	G $\frac{1}{8}$
Female piston rod thread		M6		M8		M10		M12	
Male piston rod thread		M8		M10x1.25		M12x1.25		M16x1.5	
Cushioning		Elastic cushioning rings/pads at both ends							
Theoretical force at 6 bar, advancing	[N]	188	295	483	754	1,178	1,870	3,016	4,712
Theoretical force at 6 bar, retracting	[N]	141	247	415	633	990	1,682	2,721	4,418
Holding force of the clamping unit	[N]	350	350	600	1,000	1,400	2,000	5,000	5,000
Max. axial backlash with clamped piston rod without load	[mm]	0.5				0.7			

Operating conditions

Operating pressure	[bar]	1.5 ... 10
Min. release pressure	[bar]	3
Ambient temperature ¹⁾	[°C]	-10 ... +80

1) Note operating range of proximity sensors.

Materials

Piston rod	High-alloy steel
Bearing cap	Anodised wrought aluminium alloy
Cylinder barrel	Smooth anodised wrought aluminium alloy
End cap	Anodised wrought aluminium alloy
Seals	NBR, TPE-U (PUR)

Compact cylinders ADN-...-KP, standard hole pattern, with clamping unit

1

Order code – Double-acting with clamping unit

		ADN	-		-		-	KP	-		-	P	-		-	A
Type																
ADN	Double-acting compact cylinder															
Piston Ø [mm]																
	Stroke [mm]															
20, 25	-	10 ... 300														
32, 40, 50, 63	-	10 ... 400														
80, 100	-	10 ... 500														
Clamping unit																
KP	Attached															
Piston rod thread																
A	Male thread															
I	Female thread															
Cushioning																
P	Elastic cushioning rings/pads at both ends															
Position sensing																
A	Via proximity sensor															

Ordering – Product options

<input type="checkbox"/> <input type="checkbox"/> <input type="checkbox"/> <input type="checkbox"/>	Configurable product	This product and all its options can be ordered using the configurator.	The configurator can be found under Products on the DVD or → www.festo.com/catalogue/...	Enter the type code in the search field.
--	-----------------------------	--	--	--

Technical data – Single-acting, pushing



1

Technical data		Dimensions → 117				
Piston Ø		12	16	20	25	32
Pneumatic connection		M5	M5	M5	M5	G $\frac{1}{8}$
Piston rod thread	Female	M3	M4	M6	M6	M8
	Male	M5	M6	M8	M8	M10x1.25
Cushioning		Elastic cushioning rings/pads at both ends				
Theoretical force at 6 bar, advancing	[N]	59	95	161	260	440

Piston Ø		40	50	63	80	100
Pneumatic connection		G $\frac{1}{8}$	G $\frac{1}{8}$	G $\frac{1}{8}$	G $\frac{1}{8}$	G $\frac{1}{8}$
Piston rod thread	Female	M8	M10	M10	M12	M12
	Male	M10x1.25	M12x1.25	M12x1.25	M16x1.5	M16x1.5
Cushioning		Elastic cushioning rings/pads at both ends				
Theoretical force at 6 bar, advancing	[N]	700	1,100	1,780	2,870	4,510

Operating conditions		12	16	20	25	32	40	50	63	80	100	
Operating pressure	[bar]	1.5 ... 10		1 ... 10								
Ambient temperature ¹⁾	°C	-20 ... +80										
	S6 °C	0 ... +120										

1) Note operating range of proximity sensors.

Materials	
Piston rod	High-alloy steel
Bearing cap	Anodised wrought aluminium alloy
Cylinder barrel	Smooth anodised wrought aluminium alloy
End cap	Anodised wrought aluminium alloy
Seals	TPE-U (PUR)

Compact cylinders AEN, to ISO 21287

1 Order code – Single acting, pushing

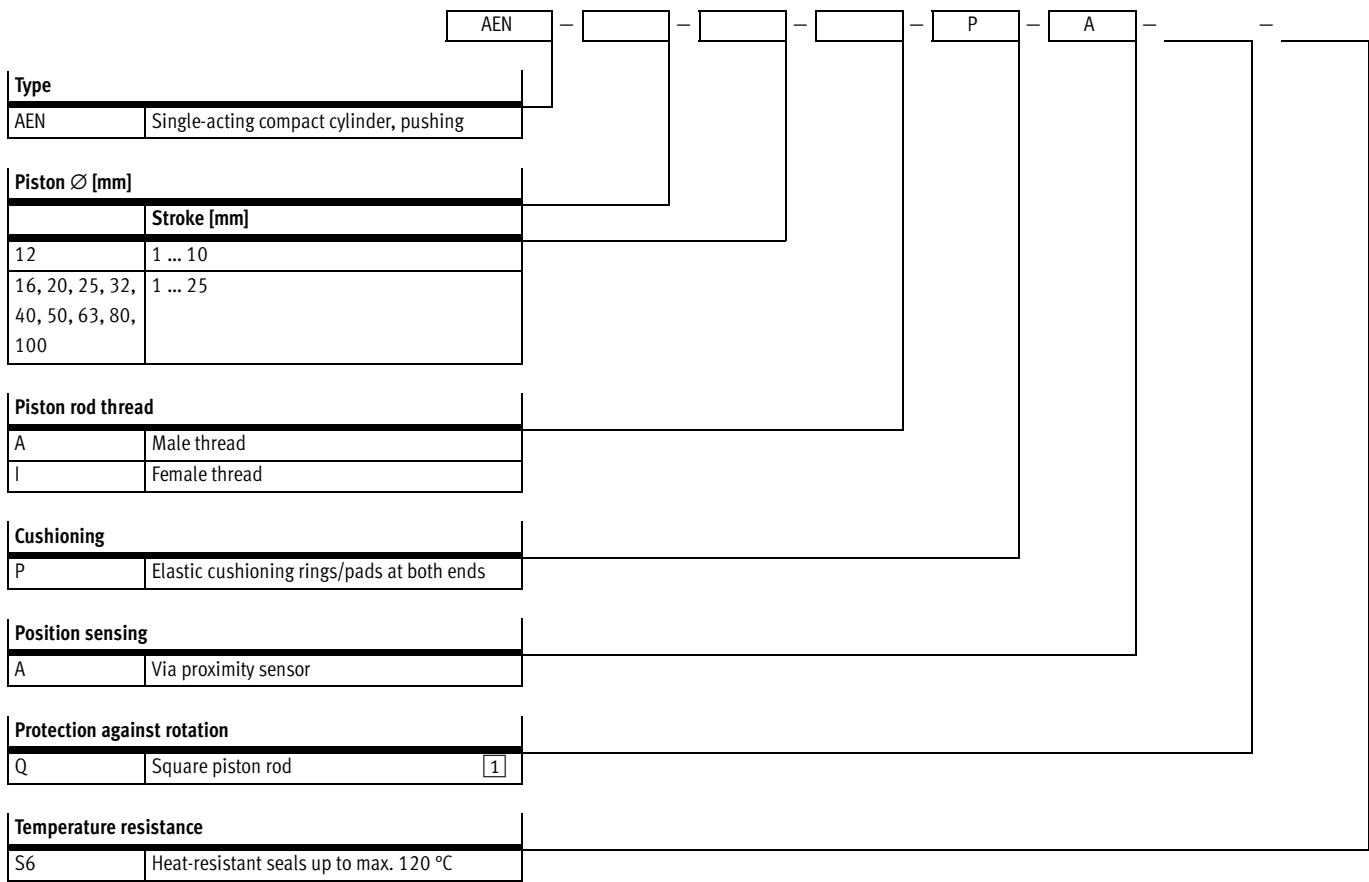

¹ Not with piston Ø 12 mm.

Ordering – Product options

Configurable product

This product and all its options can be ordered using the configurator.

The configurator can be found under Products on the DVD or
[→ www.festo.com/catalogue/...](http://www.festo.com/catalogue/...)

Enter the type code in the search field.

Accessories

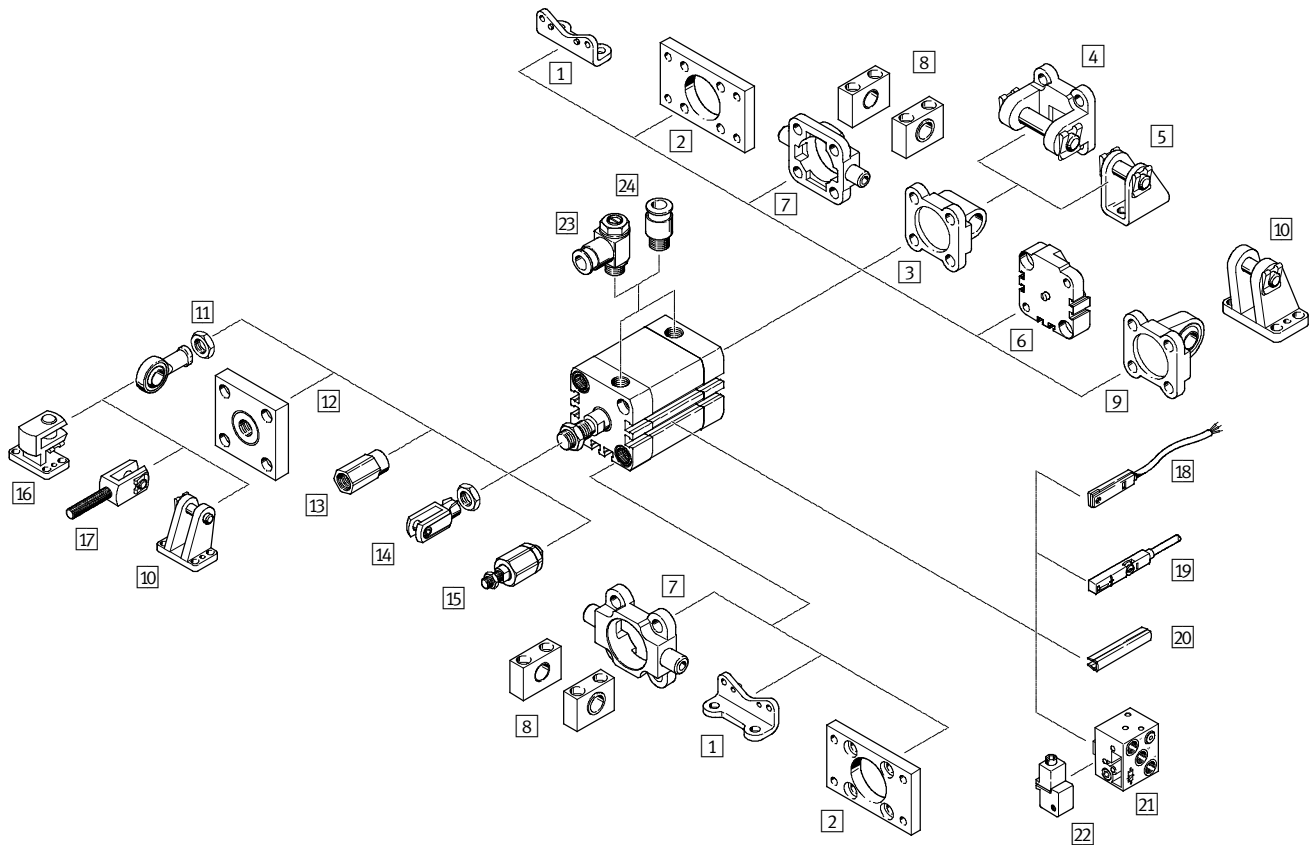





	Basic design	Q	S2	→ Page/online
1	Foot mounting HNA	■	■	114
2	Flange mounting FNC	■	■	114
3	Swivel flange SNCL	■	■	114
4	Swivel flange SNCB	■	■	114
5	Clevis foot LBN	■	■	114
	Clevis foot CRLBN	■	■	adn
6	Multi-position kit DPNA	■	■	114
7	Trunnion flange ZNCF	■	■	114
	Trunnion flange CRZNG	■	■	adn
8	Trunnion support LNZG	■	■	114
9	Swivel flange SNCS	■	-	114
10	Clevis foot LBG	■	-	114
11	Rod eye SGS	■	-	114
	Rod eye CRSGS	■	■	adn
12	Coupling piece KSG/KSZ	■	■	115
13	Adapter AD	■	-	115
14	Rod clevis SG	■	■	115
	Rod clevis CRSG	■	■	adn
15	Self-aligning rod coupler FK	■	-	115
16	Right-angle clevis foot LQG	■	-	115
17	Rod clevis SGA	■	-	115
18	Proximity sensor SME-/SMT-8 and connecting cable NEBU	■	■	116
19	Proximity sensor SME-/SMT-8M and connecting cable NEBU	■	■	116
20	Slot cover ABP-5-S	■	■	116
21	Proximity sensor SMPO-8E	■	■	adn
22	Mounting kit SMB-8E	■	■	adn
23	One-way flow control valve GRLA/GRLZ	■	■	116
24	Push-in fitting QS	■	■	908

Compact cylinders ADN/AEN, to ISO 21287

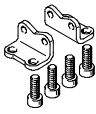
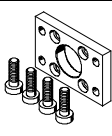
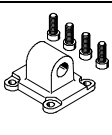
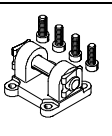

Accessories – Ordering data

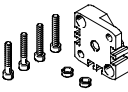
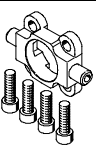
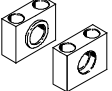
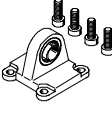
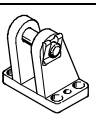
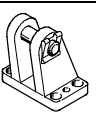

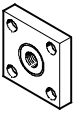
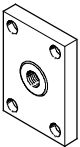

1

	For Ø	Part No.	Type
1 Foot mounting Dimensions online: → adn			
	12	537237	HNA-12
	16	537238	HNA-16
	20	537239	HNA-20
	25	537240	HNA-25
	32	537241	HNA-32
	40	537242	HNA-40
	50	537243	HNA-50
	63	537244	HNA-63
	80	537249	HNA-80
	100	537250	HNA-100
2 Flange mounting Dimensions online: → adn			
	12	537245	FNC-12
	16	537246	FNC-16
	20	537247	FNC-20
	25	537248	FNC-25
	32	★ 174376	FNC-32
	40	★ 174377	FNC-40
	50	174378	FNC-50
	63	★ 174379	FNC-63
	80	174380	FNC-80
	100	174381	FNC-100
	125	174382	FNC-125
	3 Swivel flange Dimensions online: → adn		
	12	537790	SNCL-12
	16	537791	SNCL-16
	20	537792	SNCL-20
	25	537793	SNCL-25
	32	★ 174404	SNCL-32
	40	★ 174405	SNCL-40
	50	174406	SNCL-50
	63	★ 174407	SNCL-63
	80	174408	SNCL-80
	100	174409	SNCL-100
	125	174410	SNCL-125
	4 Swivel flange Dimensions online: → adn		
	32	★ 174390	SNCB-32
	40	★ 174391	SNCB-40
	50	★ 174392	SNCB-50
	63	★ 174393	SNCB-63
	80	174394	SNCB-80
	100	174395	SNCB-100
	125	174396	SNCB-125
	5 Clevis foot Technical data online: → lbn		
	12, 16	★ 6058	LBN-12/16
	20, 25	★ 6059	LBN-20/25

	For Ø	Part No.	Type
6 Multi-position kit Dimensions online: → adn			
	12	537263	DPNA-12
	16	537264	DPNA-16
	20	537265	DPNA-20
	25	537266	DPNA-25
	32	537267	DPNA-32
	40	537268	DPNA-40
	50	537269	DPNA-50
	63	532270	DPNA-63
	80	537271	DPNA-80
	100	537272	DPNA-100
7 Trunnion flange Dimensions online: → adn			
	32	174411	ZNCF-32
	40	174412	ZNCF-40
	50	174413	ZNCF-50
	63	174414	ZNCF-63
	80	174415	ZNCF-80
	100	174416	ZNCF-100
	125	174417	ZNCF-125
8 Trunnion support Dimensions online: → adn			
	32	32959	LNZG-32
	40, 50	32960	LNZG-40/50
	63, 80	32961	LNZG-63/80
	100, 125	32962	LNZG-100/125
9 Swivel flange Dimensions online: → adn			
	32	★ 174397	SNCS-32
	40	★ 174398	SNCS-40
	50	★ 174399	SNCS-50
	63	★ 174400	SNCS-63
	80	174401	SNCS-80
	100	174402	SNCS-100
	125	174403	SNCS-125
	10 Clevis foot Technical data online: → lbg		
	32	31761	LBG-32
	40	31762	LBG-40
	50	31763	LBG-50
	63	31764	LBG-63
	80	31765	LBG-80
	100	31766	LBG-100
	125	31767	LBG-125
Clevis foot used with rod eye SGS Technical data online: → lbg			
	32, 40	31761	LBG-32
	50, 63	31762	LBG-40
	80, 100	31763	LBG-50
	80, 100	31764	LBG-63
	125	31765	LBG-80
	125	31766	LBG-100
11 Rod eye Technical data online: → sgs			
	16	★ 9254	SGS-M6
	20, 25	★ 9255	SGS-M8
	32, 40	★ 9261	SGS-M10x1,25
	50, 63	★ 9262	SGS-M12x1,25
	80, 100	★ 9263	SGS-M16x1,5
	125	9264	SGS-M20x1,5

Accessories – Ordering data

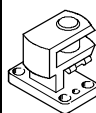
	For Ø	Part No.	Type
12 Coupling piece Technical data online: → ksg			
	32	32963	KSG-M10x1,25
	40	32963	KSG-M10x1,25
	50, 63	32964	KSG-M12x1,25
	80, 100	32965	KSG-M16x1,5
	125	32966	KSG-M20x1,5
12 Coupling piece Technical data online: → ksz			
	16	36123	KSZ-M6
	20, 25	36124	KSZ-M8
	32, 40	36125	KSZ-M10x1,25
	50, 63	36126	KSZ-M12x1,25
	80, 100	36127	KSZ-M16x1,5
	125	36128	KSZ-M20x1,5
13 Adapter Technical data online: → ad			
	16	157328	AD-M6-M5
		157329	AD-M6-1/8
		157330	AD-M6-1/4
	20, 25	157331	AD-M8-1/8
		157332	AD-M8-1/4
	32	157333	AD-M10x1,25-1/8
	40	157334	AD-M10x1,25-1/4
	50	160256	AD-M12x1,25-1/4
	63	160257	AD-M12x1,25-3/8

	For Ø	Part No.	Type
14 Rod clevis Technical data online: → sg			
	16	★ 3110	SG-M6
	20, 25	★ 3111	SG-M8
	32, 40	★ 6144	SG-M10x1,25
	50, 63	★ 6145	SG-M12x1,25
	80, 100	★ 6146	SG-M16x1,5
	125	6147	SG-M20x1,5
	15 Self-aligning rod coupler Technical data online: → fk		
	12	30184	FK-M5
	16	★ 2061	FK-M6
	20, 25	★ 2062	FK-M8
	32, 40	★ 6140	FK-M10x1,25
	50, 63	★ 6141	FK-M12x1,25
	80, 100	★ 6142	FK-M16x1,5
	125	6143	FK-M20x1,5
16 Clevis foot used with rod eye SGS Technical data online: → lqg			
	32, 40	31768	LQG-32
	50, 63	31769	LQG-40
	80, 100	31770	LQG-50
		31771	LQG-63
	125	31772	LQG-80
		31773	LQG-100
17 Rod clevis Technical data online: → sga			
	32, 40	32954	SGA-M10x1,25
	50, 63	10767	SGA-M12x1,25
	80, 100	10768	SGA-M16x1,25
	125	10769	SGA-M20x1,5

Compact cylinders ADN/AEN, to ISO 21287

Accessories – Ordering data

1

	For Ø		Part No.	Type	
18/19 Proximity sensor for T-slot, magneto-resistive – N/O contact Technical data → 737					
	PNP, cable	★	574335	SMT-8M-A-PS-24V-E-2,5-OE	
	PNP, plug	★	574334	SMT-8M-A-PS-24V-E-0,3-M8D	
	PNP, plug	★	574337	SMT-8M-A-PS-24V-E-0,3-M12	
	NPN, cable	★	574338	SMT-8M-A-NS-24V-E-2,5-OE	
	NPN, plug	★	574339	SMT-8M-A-NS-24V-E-0,3-M8D	
18/19 Proximity sensor for T-slot, magneto-resistive – N/C contact Technical data → 737					
	PNP, cable	★	574340	SMT-8M-A-PO-24V-E-7,5-OE	
Magnetic reed – N/O contact Technical data → 732					
	Cable	★	543862	SME-8M-DS-24V-K-2,5-OE	
	Cable	★	543863	SME-8M-DS-24V-K-5,0-OE	
	Cable	★	543872	SME-8M-ZS-24V-K-2,5-OE	
	Plug	★	543861	SME-8M-DS-24V-K-0,3-M8D	
Magnetic reed – N/C contact Technical data → 734					
	Cable	★	150855	SME-8-K-LED-24	
	Plug		150857	SME-8-S-LED-24	
Magnetic reed – N/C contact Technical data → 734					
	Cable		160251	SME-8-O-K-LED-24	
18/19 Connecting cable, straight socket Technical data → 949					
	2.5 m	★	541333	NEBU-M8G3-K-2.5-LE3	
	5 m	★	541334	NEBU-M8G3-K-5-LE3	
	2.5 m		541363	NEBU-M12G5-K-2.5-LE3	
	5 m		541364	NEBU-M12G5-K-5-LE3	
Angled socket Technical data → 949					
	2.5 m	★	541338	NEBU-M8W3-K-2.5-LE3	
	5 m	★	541341	NEBU-M8W3-K-5-LE3	
	2.5 m		541367	NEBU-M12W5-K-2.5-LE3	
	5 m		541370	NEBU-M12W5-K-5-LE3	
20 Slot cover¹⁾					
			151681	ABP-5-S	

1) Packaging unit 2x 0.5 m.

	For Ø	Connection		Part No.	Type
		Thread	O.D.		
23 One-way flow control valve with slotted head screw, metal²⁾ for exhaust air flow control Technical data → 611					
	12, 16, 20, 25	M5	3	★ 193137	GRLA-M5-QS-3-D
	32	G ¹ / ₈	4	★ 193143	GRLA-1/8-QS-4-D
	40, 50, 63		6	★ 193144	GRLA-1/8-QS-6-D
For supply air flow control Technical data → 611					
	12, 16, 20, 25	M5	3	★ 193153	GRLZ-M5-QS-3-D
	32	G ¹ / ₈	4	★ 193157	GRLZ-1/8-QS-4-D
	40, 50, 63		6	★ 193158	GRLZ-1/8-QS-6-D

2) The recommended flow control valves are based on a tubing length to the valve of 1 m. For deviations of ±50%, flow control valves with a bigger or smaller flow rate must be selected to guarantee the optimum flow control function and cylinder speed.

Dimensions

Basic design – Ø 12 ... 63 mm

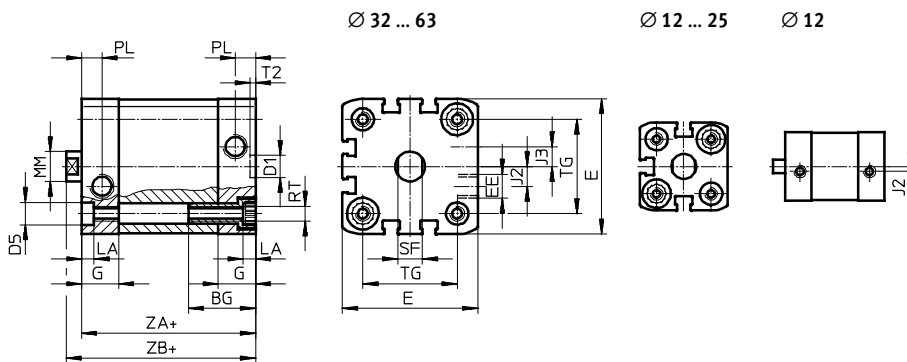

Basic design – Ø 80 ... 125 mm

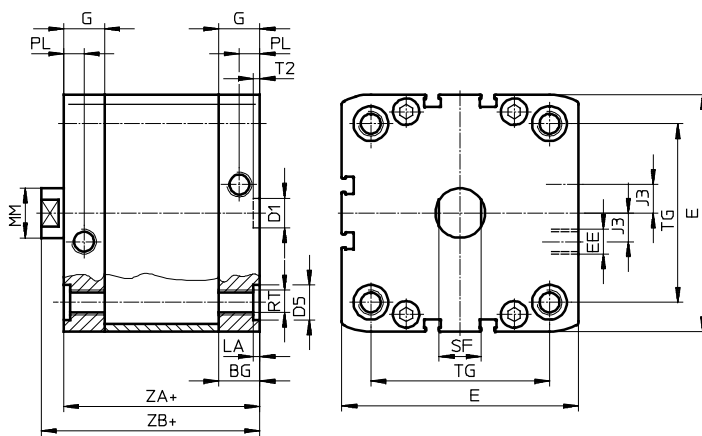

+ = plus stroke length

Ø	BG	D1	D5	E	EE	G	J2	J3	LA	MM	PL	RT	SF	T2	TG	ZA	ZB	
[mm]	min.	Ø H9	Ø F9						+0.2	Ø h8	+0.2		h13	+0.1	±0.2	±0.3	+1.2	
12	17	9	6	27.5 ^{+0.3}	M5	10.5	2	-	3.5	6	6	M4	5	2.1	16	35	39.2	
16				29 ^{+0.3}		11	2.6	8		7			18		39.7			
20	19.5		9	35.5 ^{+0.3}		12		5	10	M5		9	22		37	42.5		
25				39.5 ^{+0.3}			26						39		44.5			
32	26	12	9	47 ^{+0.3}	G ¹ / ₈	15	6	8	5	12	8.2	M6	10	32.5	44	50		
40				54.5 ^{+0.3}										16	38	45	51.1	
50	27		12	65.5 ^{+0.3}		16.5	11.5	2.6		20		10.5	M8		13	2.6	46.5	49
63				75.5 ^{+0.3}										72			54	62.9
80	17	12	15	95.5 ^{+0.6}	21.5	20	2.6	20	10.5	M10	17	2.6	89	67	76			
100	21.5			113.5 ^{+0.6}									110	81	92			
125	20	-	-	134.6 ^{+0.3}	G ¹ / ₄	20	21.15	-	25	M12	21	2.6	110	81	92			

Dimensions

1 Basic design

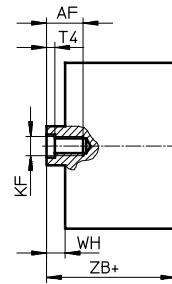
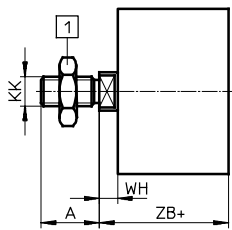

1 Hex nut DIN 439-B
only with $\varnothing 32 \dots 125$

+ = plus stroke length

S2 – Through piston rod

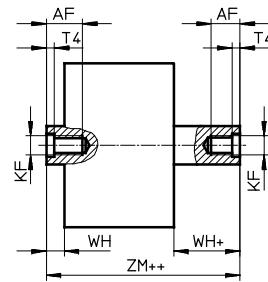
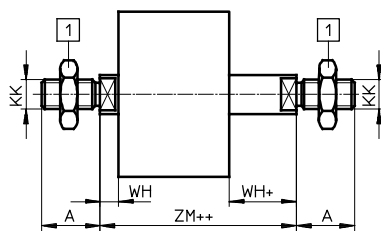

1 Hex nut DIN 439-B
only with $\varnothing 32 \dots 125$

+ = plus stroke length

++ = plus 2x stroke length

Q – Square piston rod

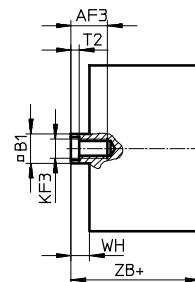
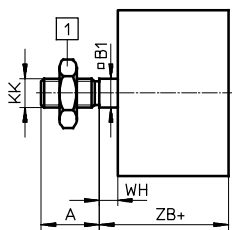

1 Hex nut DIN 439-B
only with $\varnothing 32 \dots 125$

+ = plus stroke length

Q-S2 – Square, through piston rod

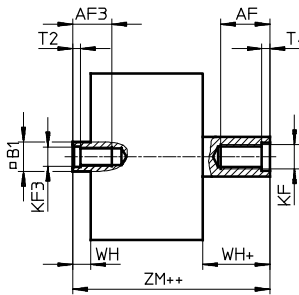
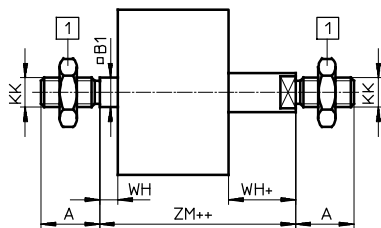

Note

The left-hand piston rod is square, the right-hand piston rod round.

+ = plus stroke length

++ = plus 2x stroke length

TT – Low temperature

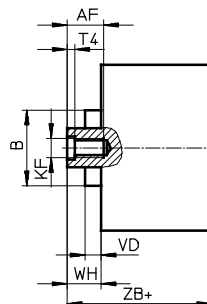
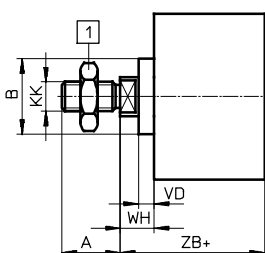

1 Hex nut DIN 439-B
only with $\varnothing 32 \dots 125$

+ = plus stroke length

Dimensions

Download CAD data → www.festo.com

1

∅ [mm]	A -0.5	A1	A2	AF min.	AF3 min.	B ∅	B1 □	D7 ∅	D8	D9 ∅	L5	KF
12	10	1 ... 10	1 ... 300	8	8	-	5.5	-	-	-	-	M3
16	12			10	10		7	4.5		3.2	3	M4
20	16	1 ... 20		14	12	18	9	6		3.8	2	M6
25			16	14	27	10	8	4.5	3	M8		
32	19		20	20	16	16	31	12	10	6	3.5	M10
40					22	20	20	35	16	-	G $\frac{1}{8}$	8
50	28	1 ... 30	1 ... 500	20	20	35	16	-	G $\frac{1}{8}$	8	-	M12
63												
80	40	1 ... 40		20	25	24	-	20	-	G $\frac{1}{4}$	11.7	-
100			28									
125	40	1 ... 40	20	25	24	-	20	-	G $\frac{1}{4}$	11.7	-	M16

∅ [mm]	KF3	KK	T2	T3	T4	VD	WH +1.3		ZB +1.2		ZM
								TT		TT	
12	M3	M5	1.5	-	1.5	-	4.2	-	39.2	-	44.5 ^{+0.5}
16	M4	M6					4.7		39.7		45.7 ^{+0.5}
20	M5	M8	2	2	2.6	5.2	5.5	10.5	42.5	47.5	49.5 ^{+0.5}
25									44.5	49.5	51.5 ^{+0.5}
32	M6	M10x1.25	2.6	2.6	3.3	6.4	6	12.5	50	56.5	57.5 ^{+0.5}
40							6.1		51.1	57.5	58.6 ^{+0.6}
50	M8	M12x1.25	3.3	3.3	4.7	6.4	8.2	14.7	53.2	59.7	62.8 ^{+0.6}
63							8.1	14.6	57.1	63.6	66.6 ^{+0.6}
80	M10	M16x1.5	4.7	4.7	6.1	6.4	8.9	15.4	62.9	69.4	73.2 ^{+0.6}
100							9	15.5	76	82.5	86.4 ^{+0.6}
125	M12	M20x1.5	6.1	-	7	-	11	-	92	-	104.4 ^{+0.6}

Compact cylinders ADN-...-KP, standard hole pattern, with clamping unit

Dimensions

1 Basic design – Ø 20 ... 63 mm

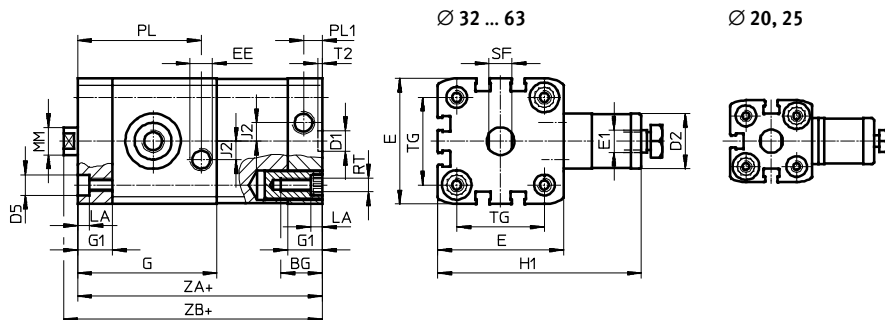

Only direct mounting is permitted with this variant.

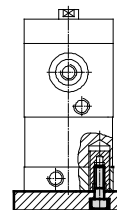

+ = plus stroke length

Basic design – Ø 80, 100 mm

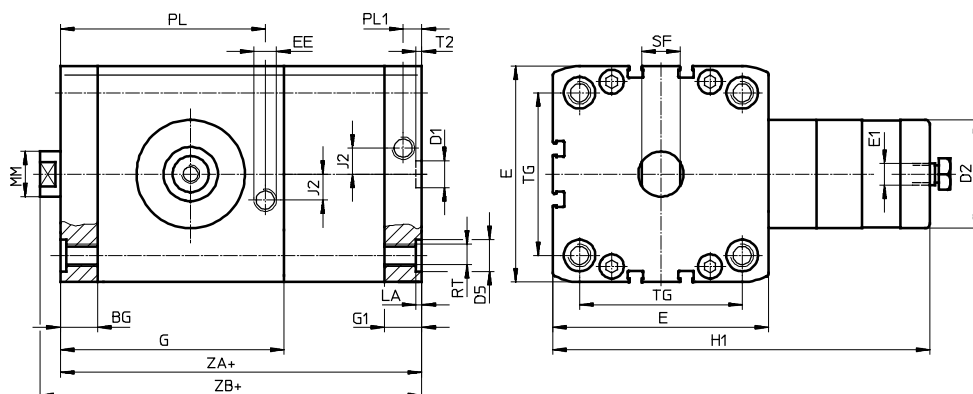

Ø	BG	D1	D2	D5	E	E1	EE	G	G1	H1	J2
[mm]	min.	Ø H9	Ø	Ø F9							
20	19.5	9	20	9	35.5 ^{+0.3}	M5	M5	49.8	12	63	2.6
25					39.5 ^{+0.3}			50.6		65	
32					47 ^{+0.3}			56.4		68	
40	26	9	24	9	54.5 ^{+0.3}	G ¹ / ₈	G ¹ / ₈	60.4	15	89	8
50					65.5 ^{+0.3}			67.4		108	
63	27	12	38	12	75.5 ^{+0.3}			76.8		76.8	120
80	17	12	48	15	95.5 ^{+0.6}	G ¹ / ₈	G ¹ / ₈	99	16.5	167	11.5
100	21.5				113.5 ^{+0.6}			99.6	21.5	176	

Ø	LA	MM	PL	PL1	RT	SF	T2	TG	ZA	ZB	
[mm]	+0.2	Ø h8	+0.2	+0.2		h13	+0.2	±0.2	±0.3	+1.2	
20	5	10	42.8	6	M5	9	2.1	22	74.8	80.8	
25			44.6					26	77.6	83.1	
32			49.6					32.5	85.4	91.4	
40		53.6	38	90.4	96.5						
50		60.6	20	70	8.2	M8	17	2.6	46.5	97.4	105.6
63		70							56.5	110.8	118.9
80	2.6	25	90.7	10.5	M10	21	2.6	72	136.5	145.4	
100			88.6					89	145.1	154.1	

Compact cylinders ADN-...-KP, standard hole pattern, with clamping unit

Dimensions

Basic design

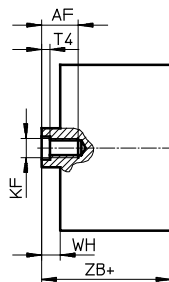
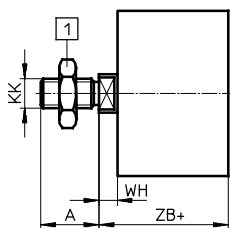

1 Hex nut DIN 439-B
only with Ø 32 ... 100

+ = plus stroke length

Ø	A	AF	KF	KK	T4	WH	ZB
[mm]	-0.5	min.				+1.3	+1.2
20	16	14	M6	M8	2.6	5.5	80.8
25						83.1	
32	19	16	M8	M10x1.25	3.3	6	91.4
40						96.5	
50	22	20	M10	M12x1.25	4.7	8.2	105.6
63						118.9	
80						145.4	
100	28		M12	M16x1.5	6.1	9	154.1

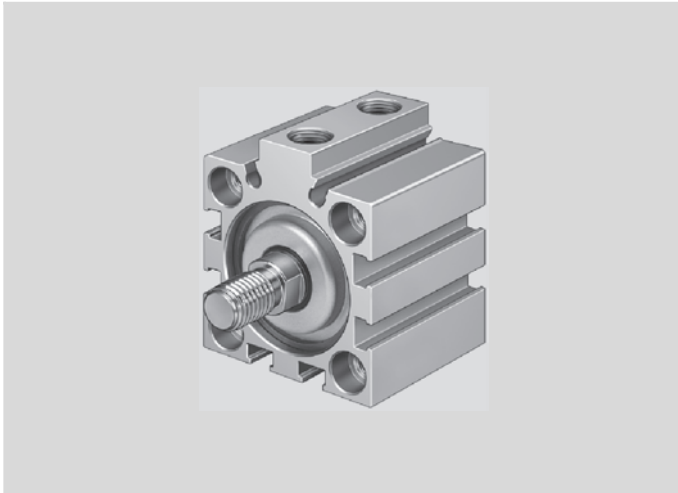

- Compact cylinders for short strokes and tight fitting spaces
- Mounting hole pattern to ISO 15552 from \varnothing 32 mm
- Application-oriented housing and piston rod options
- Supply ports and profile slot for proximity sensors on one side
- ★ Quick ordering of basic designs → 126

→ www.festo.com/catalogue/advc

Product range overview

Type/function	Piston \varnothing [mm]	Stroke [mm]	Force [N]	Product options					→ Page/ online
				Piston rod thread			P	A	
A	I	-							
Double-acting	ADVC								
	4	2.5, 5	7.5	■	-	■	■	-	124
	6, 10	5, 10	17 ... 47	■	-	■	■	■	
	12	5, 10	68	■	■	■	■	■	
	16, 20, 25	5, 10, 15, 20, 25	121 ... 295	■	■	-	■	■	
	32, 40	5, 10, 15, 20, 25	483, 754	■	■	-	■	■	
50, 63, 80, 100	10, 15, 20, 25	1,178 ... 4,712	■	■	-	■	■		
Single-acting	AEVC								
	4	2.5, 5	5	■	-	■	■	-	128
	6, 10	5, 10	11 ... 41	■	-	■	■	■	
	12	5, 10	59	■	■	■	■	■	
	16, 20, 25	5, 10, 25	105 ... 270	■	■	-	■	■	
	32	5, 10, 25	450	■	■	-	■	■	
40, 50, 63, 80, 100	10, 25	700 ... 4,500	■	■	-	■	■		

Product options

A	Male thread	P	Elastic cushioning rings/pads at both ends
I	Female thread	A	Position sensing
-	Without thread		

Short-stroke cylinders ADVC

Technical data – Double-acting

1

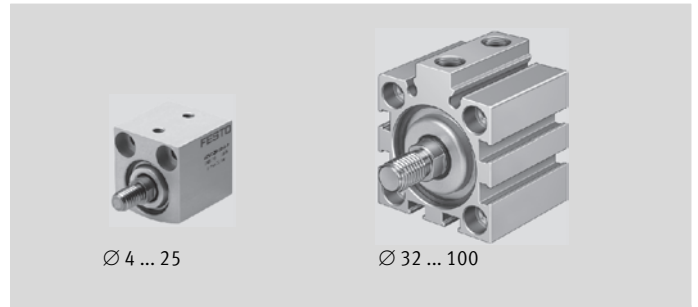
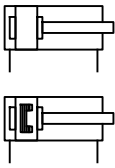

Ø 4 ... 25

Ø 32 ... 100

Technical data								Dimensions → 134
Piston Ø		4	6	10	12	16	20	25
Pneumatic connection		M3	M3	M5	M5	M5	M5	M5
Female piston rod thread		–	–	–	M3	M4	M5	M5
Male piston rod thread		M2	M3	M4	M5	M6	M8	M8
Cushioning		Elastic cushioning rings/pads at both ends						
Theoretical force at 6 bar, advancing	[N]	7.5	17	47	68	121	189	295
Theoretical force at 6 bar, retracting	[N]	5.7	13	40	51	91	141	247
Piston Ø		32	40	50	63	80	100	
Pneumatic connection		G1/8	G1/8	G1/8	G1/8	G1/8	G1/4	
Female piston rod thread		M6	M6	M8	M8	M10	M12	
Male piston rod thread		M10x1.25	M10x1.25	M12x1.25	M12x1.25	M16x1.5	M20x1.5	
Cushioning		Elastic cushioning rings/pads at both ends						
Theoretical force at 6 bar, advancing	[N]	483	754	1,178	1,870	3,016	4,712	
Theoretical force at 6 bar, retracting	[N]	415	686	1,056	1,750	2,847	4,418	

Operating conditions														
Piston Ø		4	6	10	12	16	20	25	32	40	50	63	80	100
Operating pressure	[bar]	2 ... 8	1.5 ... 8	1 ... 8	1 ... 10				0.6 ... 10					
Ambient temperature ¹⁾	[°C]	–20 ... +80												

1) Note operating range of proximity sensors.

Materials														
Piston Ø		4											6 ... 100	
Piston rod		Anodised wrought aluminium alloy							High-alloy steel					
Bearing cap		Anodised wrought aluminium alloy												
Cylinder barrel		Anodised wrought aluminium alloy												
End cap		Anodised wrought aluminium alloy												
Seals		HNBR, NBR							HNBR, TPE-U (PU)					

Order code – Double-acting

		ADVC	–		–		–		–	P	–	
Type												
ADVC	Double-acting short-stroke cylinder											
Piston Ø [mm]												
	Stroke [mm]											
4	2,5, 5											
6, 10, 12	5, 10											
16, 20, 25	5, 10, 15, 20, 25											
32, 40	5, 10, 15, 20, 25											
50, 63, 80, 100	10, 15, 20, 25											
Piston rod thread												
A	Male thread											
I	Female thread 1											
–	Without thread 2											
Cushioning												
P	Elastic cushioning rings/pads at both ends											
Position sensing												
–	None											
A	Via proximity sensor 3											

1 Not with piston Ø 4, 6 and 10 mm.

2 Only for piston Ø 4, 6, 10 and 12 mm.

3 From piston Ø 6 mm.

Ordering – Product options

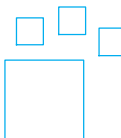

Configurable product

This product and all its options can be ordered using the configurator.

The configurator can be found under Products on the DVD or

→ www.festo.com/catalogue/...

Enter the type code in the search field.

Short-stroke cylinders ADVC

★ Quick ordering

1

Male thread

Part No.	Type
Piston Ø 12 mm	
188094	ADVC-12-5-A-P
188095	ADVC-12-10-A-P
188092	ADVC-12-5-A-P-A
188093	ADVC-12-10-A-P-A
Piston Ø 16 mm	
188123	ADVC-16-5-A-P
188124	ADVC-16-10-A-P
188125	ADVC-16-15-A-P
188126	ADVC-16-20-A-P
188127	ADVC-16-25-A-P
188118	ADVC-16-5-A-P-A
188119	ADVC-16-10-A-P-A
188120	ADVC-16-15-A-P-A
188121	ADVC-16-20-A-P-A
188122	ADVC-16-25-A-P-A
Piston Ø 20 mm	
188155	ADVC-20-5-A-P
188156	ADVC-20-10-A-P
188157	ADVC-20-15-A-P
188158	ADVC-20-20-A-P
188159	ADVC-20-25-A-P
188150	ADVC-20-5-A-P-A
188151	ADVC-20-10-A-P-A
188152	ADVC-20-15-A-P-A
188153	ADVC-20-20-A-P-A
188154	ADVC-20-25-A-P-A

Part No.	Type
Piston Ø 25 mm	
188187	ADVC-25-5-A-P
188188	ADVC-25-10-A-P
188189	ADVC-25-15-A-P
188190	ADVC-25-20-A-P
188191	ADVC-25-25-A-P
188182	ADVC-25-5-A-P-A
188183	ADVC-25-10-A-P-A
188184	ADVC-25-15-A-P-A
188185	ADVC-25-20-A-P-A
188186	ADVC-25-25-A-P-A
Piston Ø 32 mm	
188219	ADVC-32-5-A-P
188220	ADVC-32-10-A-P
188221	ADVC-32-15-A-P
188222	ADVC-32-20-A-P
188223	ADVC-32-25-A-P
188214	ADVC-32-5-A-P-A
188215	ADVC-32-10-A-P-A
188216	ADVC-32-15-A-P-A
188217	ADVC-32-20-A-P-A
188218	ADVC-32-25-A-P-A

Part No.	Type
Piston Ø 40 mm	
188247	ADVC-40-5-A-P
188248	ADVC-40-10-A-P
188249	ADVC-40-15-A-P
188250	ADVC-40-20-A-P
188251	ADVC-40-25-A-P
188242	ADVC-40-5-A-P-A
188243	ADVC-40-10-A-P-A
188244	ADVC-40-15-A-P-A
188245	ADVC-40-20-A-P-A
188246	ADVC-40-25-A-P-A
Piston Ø 50 mm	
188272	ADVC-50-10-A-P
188273	ADVC-50-15-A-P
188274	ADVC-50-20-A-P
188275	ADVC-50-25-A-P
188268	ADVC-50-10-A-P-A
188269	ADVC-50-15-A-P-A
188270	ADVC-50-20-A-P-A
188271	ADVC-50-25-A-P-A
Piston Ø 63 mm	
188296	ADVC-63-10-A-P
188297	ADVC-63-15-A-P
188298	ADVC-63-20-A-P
188299	ADVC-63-25-A-P
188292	ADVC-63-10-A-P-A
188293	ADVC-63-15-A-P-A
188294	ADVC-63-20-A-P-A
188295	ADVC-63-25-A-P-A

★ Quick ordering

Female thread

Part No.	Type
Piston Ø 12 mm	
188090	ADVC-12-5-I-P
188091	ADVC-12-10-I-P
188088	ADVC-12-5-I-P-A
188089	ADVC-12-10-I-P-A
Piston Ø 16 mm	
188113	ADVC-16-5-I-P
188114	ADVC-16-10-I-P
188115	ADVC-16-15-I-P
188116	ADVC-16-20-I-P
188117	ADVC-16-25-I-P
188108	ADVC-16-5-I-P-A
188109	ADVC-16-10-I-P-A
188110	ADVC-16-15-I-P-A
188111	ADVC-16-20-I-P-A
188112	ADVC-16-25-I-P-A
Piston Ø 20 mm	
188145	ADVC-20-5-I-P
188146	ADVC-20-10-I-P
188147	ADVC-20-15-I-P
188148	ADVC-20-20-I-P
188149	ADVC-20-25-I-P
188140	ADVC-20-5-I-P-A
188141	ADVC-20-10-I-P-A
188142	ADVC-20-15-I-P-A
188143	ADVC-20-20-I-P-A
188144	ADVC-20-25-I-P-A

Part No.	Type
Piston Ø 25 mm	
188177	ADVC-25-5-I-P
188178	ADVC-25-10-I-P
188179	ADVC-25-15-I-P
188180	ADVC-25-20-I-P
188181	ADVC-25-25-I-P
188172	ADVC-25-5-I-P-A
188173	ADVC-25-10-I-P-A
188174	ADVC-25-15-I-P-A
188175	ADVC-25-20-I-P-A
188176	ADVC-25-25-I-P-A
Piston Ø 32 mm	
188209	ADVC-32-5-I-P
188210	ADVC-32-10-I-P
188211	ADVC-32-15-I-P
188212	ADVC-32-20-I-P
188213	ADVC-32-25-I-P
188204	ADVC-32-5-I-P-A
188205	ADVC-32-10-I-P-A
188206	ADVC-32-15-I-P-A
188207	ADVC-32-20-I-P-A
188208	ADVC-32-25-I-P-A

Part No.	Type
Piston Ø 40 mm	
188237	ADVC-40-5-I-P
188238	ADVC-40-10-I-P
188239	ADVC-40-15-I-P
188240	ADVC-40-20-I-P
188241	ADVC-40-25-I-P
188232	ADVC-40-5-I-P-A
188233	ADVC-40-10-I-P-A
188234	ADVC-40-15-I-P-A
188235	ADVC-40-20-I-P-A
188236	ADVC-40-25-I-P-A
Piston Ø 50 mm	
188264	ADVC-50-10-I-P
188265	ADVC-50-15-I-P
188266	ADVC-50-20-I-P
188267	ADVC-50-25-I-P
188260	ADVC-50-10-I-P-A
188261	ADVC-50-15-I-P-A
188262	ADVC-50-20-I-P-A
188263	ADVC-50-25-I-P-A
Piston Ø 63 mm	
188288	ADVC-63-10-I-P
188289	ADVC-63-15-I-P
188290	ADVC-63-20-I-P
188291	ADVC-63-25-I-P
188284	ADVC-63-10-I-P-A
188285	ADVC-63-15-I-P-A
188286	ADVC-63-20-I-P-A
188287	ADVC-63-25-I-P-A

Short-stroke cylinders AEVC

1 Technical data – Single-acting

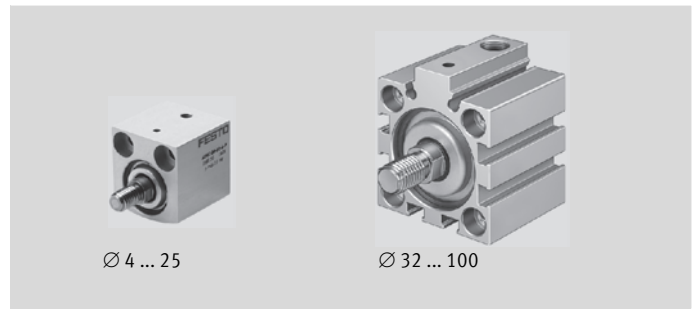
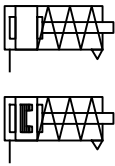

Technical data		Dimensions → 141						
Piston Ø		4	6	10	12	16	20	25
Pneumatic connection		M3	M3	M5	M5	M5	M5	M5
Female piston rod thread		–	–	–	M3	M4	M5	M5
Male piston rod thread		M2	M3	M4	M5	M6	M8	M8
Cushioning		Elastic cushioning rings/pads at both ends						
Theoretical force at 6 bar, advancing	[N]	5	11	41	59	105	170	270
Theoretical force at 6 bar, retracting	[N]	1	3	3	4	5	10 ¹⁾	15
Piston Ø		32	40	50	63	80	100	
Pneumatic connection		G1/8	G1/8	G1/8	G1/8	G1/8	G1/4	
Female piston rod thread		M6	M6	M8	M8	M10	M12	
Male piston rod thread		M10x1.25	M10x1.25	M12x1.25	M12x1.25	M16x1.5	M20x1.5	
Cushioning		Elastic cushioning rings/pads at both ends						
Theoretical force at 6 bar, advancing	[N]	450	700	1,120	1,800	2,900	4,500	
Theoretical force at 6 bar, retracting	[N]	22	28	40	50	85	140	

1) AEVC-63-5 = 5 N.

Operating conditions		4	6	10	12	16	20	25	32	40	50	63	80	100
Operating pressure	[bar]	2.5 ... 8	2 ... 8	1.5 ... 8	1.5 ... 10				1 ... 10					
Ambient temperature ²⁾	[°C]	–20 ... +80												

2) Note operating range of proximity sensors.

Materials		4	6 ... 100
Piston rod		Anodised wrought aluminium alloy	High-alloy steel
Bearing cap		Anodised wrought aluminium alloy	
Cylinder barrel		Anodised wrought aluminium alloy	
End cap		Anodised wrought aluminium alloy	
Seals		HNBR, NBR	HNBR, TPE-U (PU)

Ordering – Product options

Configurable product

This product and all its options can be ordered using the configurator.

The configurator can be found under Products on the DVD or www.festo.com/catalogue/...

Enter the type code in the search field.

Order code – Single acting

AEVC						P	
Type							
AEVC	Single-acting short-stroke cylinder						
Piston Ø [mm]							
	Stroke [mm]						
4	2.5, 5						
6, 10, 12	5, 10						
16, 20, 25	5, 10, 25						
32	5, 10, 25						
40, 50, 63, 80, 100	10, 25						
Piston rod thread							
A	Male thread						
I	Female thread						1
-	Without thread						2
Cushioning							
P	Elastic cushioning rings/pads at both ends						
Position sensing							
-	None						
A	Via proximity sensor						3

1 Not with piston Ø 4, 6 and 10 mm.

2 Only with piston Ø 4, 6, 10 and 12 mm.

3 From piston Ø 6 mm.

★ Quick ordering

Male thread

Part No.	Type
Piston Ø 12 mm	
188086	AEVC-12-5-A-P
188087	AEVC-12-10-A-P
Piston Ø 16 mm	
188105	AEVC-16-5-A-P
188106	AEVC-16-10-A-P
188107	AEVC-16-25-A-P
Piston Ø 20 mm	
188137	AEVC-20-5-A-P
188138	AEVC-20-10-A-P
188139	AEVC-20-25-A-P

Part No.	Type
Piston Ø 25 mm	
188169	AEVC-25-5-A-P
188170	AEVC-25-10-A-P
188171	AEVC-25-25-A-P
Piston Ø 32 mm	
188201	AEVC-32-5-A-P
188202	AEVC-32-10-A-P
188203	AEVC-32-25-A-P
Piston Ø 40 mm	
188230	AEVC-40-10-A-P
188231	AEVC-40-25-A-P

Part No.	Type
Piston Ø 50 mm	
188258	AEVC-50-10-A-P
188259	AEVC-50-25-A-P
Piston Ø 63 mm	
188282	AEVC-63-10-A-P
188283	AEVC-63-25-A-P

Female thread

Part No.	Type
Piston Ø 12 mm	
188082	AEVC-12-5-I-P
188083	AEVC-12-10-I-P
Piston Ø 16 mm	
188099	AEVC-16-5-I-P
188100	AEVC-16-10-I-P
188101	AEVC-16-25-I-P
Piston Ø 20 mm	
188131	AEVC-20-5-I-P
188132	AEVC-20-10-I-P
188133	AEVC-20-25-I-P

Part No.	Type
Piston Ø 25 mm	
188163	AEVC-25-5-I-P
188164	AEVC-25-10-I-P
188165	AEVC-25-25-I-P
Piston Ø 32 mm	
188195	AEVC-32-5-I-P
188196	AEVC-32-10-I-P
188197	AEVC-32-25-I-P

Part No.	Type
Piston Ø 40 mm	
188226	AEVC-40-10-I-P
188227	AEVC-40-25-I-P
Piston Ø 50 mm	
188254	AEVC-50-10-I-P
188255	AEVC-50-25-I-P
Piston Ø 63 mm	
188278	AEVC-63-10-I-P
188279	AEVC-63-25-I-P

Short-stroke cylinders ADVC/AEVC

Accessories

1 Ø 32 ... 100 mm

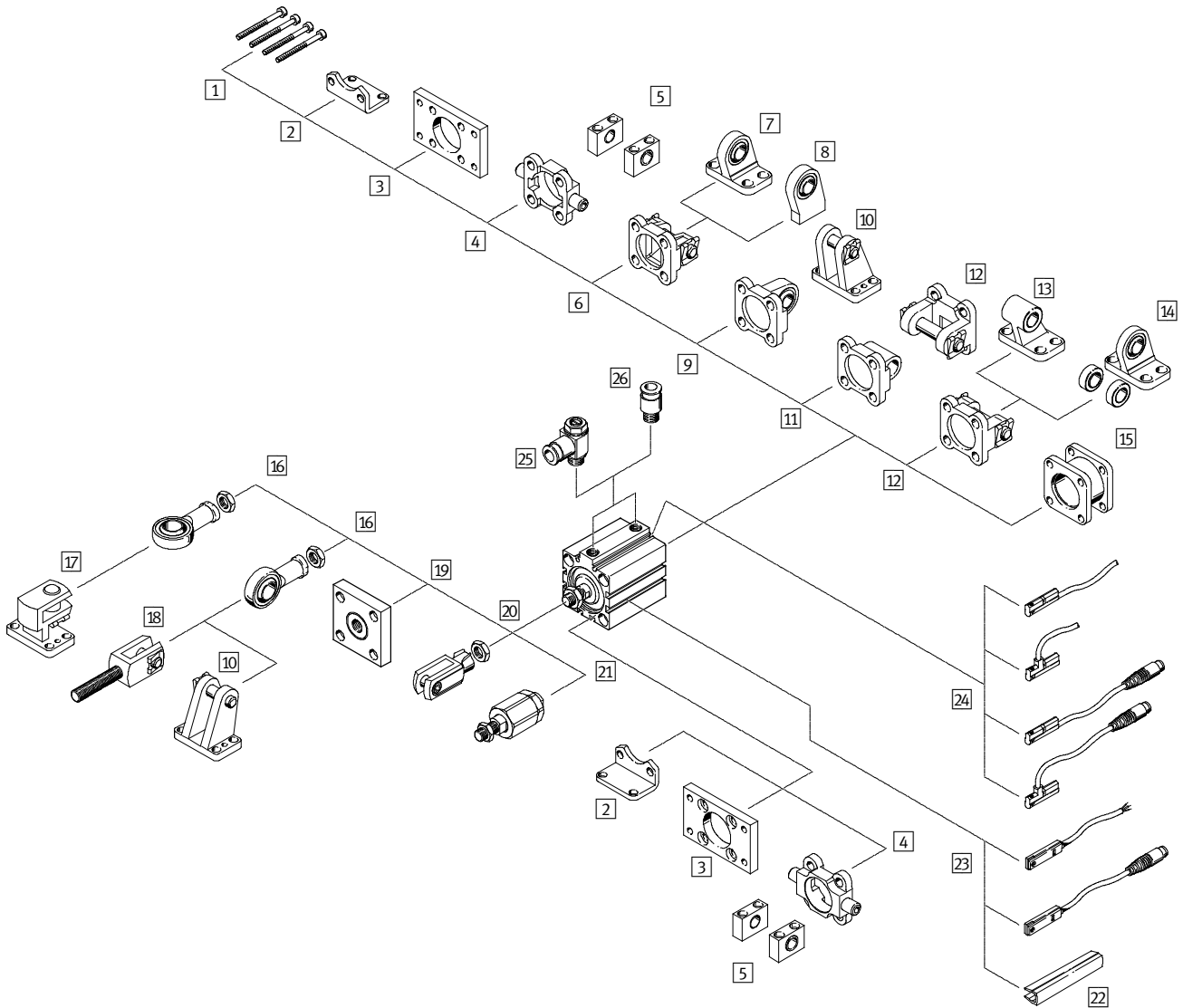

Ø 4 ... 25 mm

Without position sensing

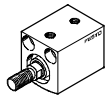

Ø 6 ... 25 mm

With position sensing

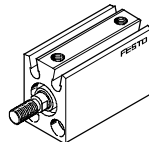

Accessories

		Piston Ø			→ Page/online
		4, 6, 12	10, 16 ... 25	32 ... 100	
1	Mounting screws (not included in the scope of delivery)	■ DIN 84	■ DIN 912	■ DIN 912	–
1	Mounting screws for Ø 80, 100 (not included in the scope of delivery)	–	–	■	131
2	Foot mounting HNC	–	–	■	131
3	Flange mounting FNC	–	–	■	131
4	Trunnion flange ZNCF	–	–	■	131
5	Trunnion support LNZG	–	–	■	131
6	Swivel flange SNC	–	–	■	131
7	Clevis foot LSNG	–	–	■	132
8	Clevis foot LSNSG	–	–	■	132
9	Swivel flange SNCS	–	–	■	132
10	Clevis foot LBG	–	–	■	132
11	Swivel flange SNCL	–	–	■	132
12	Swivel flange SNCB	–	–	■	132
13	Clevis foot LNG	–	–	■	132
14	Clevis foot LSN	–	–	■	132
15	Multi-position kit DPNC	–	–	■	132
16	Rod eye SGS	–	■	■	132
17	Right-angle clevis foot LQG	–	■	■	132
18	Rod clevis SGA	–	–	■	132
19	Coupling piece KSG	–	–	■	132
20	Rod clevis SG	–	■	■	132
21	Self-aligning rod coupler FK	■ Ø 12	■	■	133
22	Slot cover ABP-5-S	–	–	■	133
23	Proximity sensor SMT-/SME-8 and connecting cable NEBU	–	–	■	133
24	Proximity sensor SMT-/SME-10 and connecting cable NEBU	–	■	■	133
25	One-way flow control valve GRLA	■	■	■	133
26	Push-in fitting QS	■	■	■	908

Accessories – Ordering data

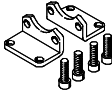
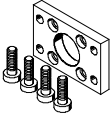
	For Ø	Part No.	Type
1 Screw¹⁾			
	80, 100		HNC, FNC, SNC, SNCS, SNCL, SNCB M10x30
	80		ZNCF M10x40
	100		ZNCF M10x50
2 Foot mounting			Dimensions online: → advc
	32	★ 174369	HNC-32
	40	★ 174370	HNC-40
	50	174371	HNC-50
	63	★ 174372	HNC-63
	80	174373	HNC-80
	100	174374	HNC-100
3 Flange mounting			Dimensions online: → advc
	32	★ 174376	FNC-32
	40	★ 174377	FNC-40
	50	174378	FNC-50
	63	★ 174379	FNC-63
	80	174380	FNC-80
	100	174381	FNC-100

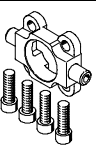
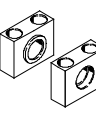
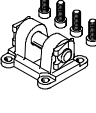

	For Ø	Part No.	Type
4 Trunnion flange			Dimensions online: → advc
	32	174411	ZNCF-32
	40	174412	ZNCF-40
	50	174413	ZNCF-50
	63	174414	ZNCF-63
	80	174415	ZNCF-80
	100	174416	ZNCF-100
5 Trunnion support			Dimensions online: → advc
	32	32959	LNZG-32
	40, 50	32960	LNZG-40/50
	63, 80	32961	LNZG-63/80
	100	32962	LNZG-100/125
6 Swivel flange			Dimensions online: → advc
	32	★ 174383	SNC-32
	40	★ 174384	SNC-40
	50	★ 174385	SNC-50
	63	★ 174386	SNC-63
	80	174387	SNC-80
	100	174388	SNC-100





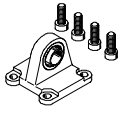
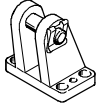
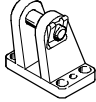
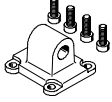
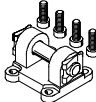

1) Packaging unit 1 piece.

Short-stroke cylinders ADVC/AEVC

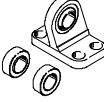







Accessories – Ordering data

1

	For Ø	Part No.	Type	
7 Clevis foot Technical data online: → lsng				
	32	31740	LSNG-32	
	40	31741	LSNG-40	
	50	31742	LSNG-50	
	63	31743	LSNG-63	
	80	31744	LSNG-80	
	100	31745	LSNG-100	
8 Clevis foot Technical data online: → lsnsg				
	32	31747	LSNSG-32	
	40	31748	LSNSG-40	
	50	31749	LSNSG-50	
	63	31750	LSNSG-63	
	80	31751	LSNSG-80	
	100	31752	LSNSG-100	
9 Swivel flange Dimensions online: → advc				
	32	★ 174397	SNCS-32	
	40	★ 174398	SNCS-40	
	50	★ 174399	SNCS-50	
	63	★ 174400	SNCS-63	
	80		174401 SNCS-80	
	100		174402 SNCS-100	
10 Clevis foot used with swivel flange SNCS Technical data online: → lbg				
	32	31761	LBG-32	
	40	31762	LBG-40	
	50	31763	LBG-50	
	63	31764	LBG-63	
	80	31765	LBG-80	
	100	31766	LBG-100	
10 Clevis foot used with rod eye SGS Technical data online: → lbg				
	32, 40	31761	LBG-32	
	50, 63	31762	LBG-40	
	80		31763	LBG-50
			31764	LBG-63
	100		31765	LBG-80
			31766	LBG-100
11 Swivel flange Dimensions online: → advc				
	32	★ 174404	SNCL-32	
	40	★ 174405	SNCL-40	
	50		174406 SNCL-50	
	63	★ 174407	SNCL-63	
	80		174408 SNCL-80	
	100		174409 SNCL-100	
12 Swivel flange Dimensions online: → advc				
	32	★ 174390	SNCB-32	
	40	★ 174391	SNCB-40	
	50	★ 174392	SNCB-50	
	63	★ 174393	SNCB-63	
	80		174394 SNCB-80	
	100		174395 SNCB-100	

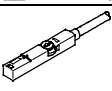
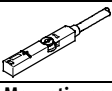
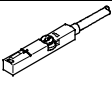
	For Ø	Part No.	Type	
13 Clevis foot Technical data online: → lng				
	32	★ 33890	LNG-32	
	40	★ 33891	LNG-40	
	50	★ 33892	LNG-50	
	63	★ 33893	LNG-63	
	80		33894 LNG-80	
	100		33895 LNG-100	
14 Clevis foot Technical data online: → lsn				
	32		5561 LSN-32	
	40		5562 LSN-40	
	50		5563 LSN-50	
	63		5564 LSN-63	
	80		5565 LSN-80	
	100		5566 LSN-100	
15 Multi-position kit Dimensions online: → advc				
	32		174418 DPNC-32	
	40		174419 DPNC-40	
	50		174420 DPNC-50	
	63		174421 DPNC-63	
	80		174422 DPNC-80	
	100		174423 DPNC-100	
16 Rod eye Technical data online: → sgs				
	10		9253 SGS-M4	
	16	★	9254 SGS-M6	
	20, 25	★	9255 SGS-M8	
	32, 40	★	9261 SGS-M10x1,25	
	50, 63	★	9262 SGS-M12x1,25	
	80	★	9263 SGS-M16x1,5	
	100		9264 SGS-M20x1,5	
	17 Right-angle clevis foot Technical data online: → lqg			
	32, 40		31768 LQG-32	
	50, 63		31769 LQG-40	
	80		31770	LQG-50
			31771	LQG-63
	100		31772	LQG-80
			31773	LQG-100
18 Rod clevis Technical data online: → sga				
	32, 40		32954 SGA-M10x1,25	
	50, 63		10767 SGA-M12x1,25	
	80		10768 SGA-M16x1,5	
	100		10769 SGA-M20x1,5	
	19 Coupling piece Technical data online: → ksg			
	32, 40		32963 KSG-M10x1,25	
	50, 63		32964 KSG-M12x1,25	
	80		32965 KSG-M16x1,5	
	100		32966 KSG-M20x1,5	
20 Rod clevis Technical data online: → sg				
	10		6532 SG-M4	
	16	★	3110 SG-M6	
	20, 25	★	3111 SG-M8	
	32, 40	★	6144 SG-M10x1,25	
	50, 63	★	6145 SG-M12x1,25	
	80	★	6146 SG-M16x1,5	
	100		6147 SG-M20x1,5	

Accessories – Ordering data

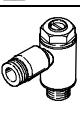
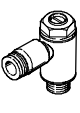
	For Ø	Part No.	Type		For Ø	Part No.	Type	
21 Self-aligning rod coupler				Technical data online: → fk				
	10	6528	FK-M4		2.5 m	★ 541333	NEBU-M8G3-K-2.5-LE3	
	12	30984	FK-M5		5.0 m	★ 541334	NEBU-M8G3-K-5-LE3	
	16	★ 2061	FK-M6			2.5 m	541363	NEBU-M12G5-K-2.5-LE3
	20, 25	★ 2062	FK-M8			5.0 m	541364	NEBU-M12G5-K-5-LE3
	32, 40	★ 6140	FK-M10x1,25		Angled socket			
	50, 63	★ 6141	FK-M12x1,25		2.5 m	★ 541338	NEBU-M8W3-K-2.5-LE3	
	80	★ 6142	FK-M16x1,5		5.0 m	★ 541341	NEBU-M8W3-K-5-LE3	
	100	6143	FK-M20x1,5		2.5 m	541367	NEBU-M12W5-K-2.5-LE3	
5.0 m			5.0 m	541370	NEBU-M12W5-K-5-LE3			
22 Slot cover¹⁾				1) Packaging unit 2x 0.5 m.				
	32, 40, 50, 63,	151680	ABP-5-S					
	80, 100							
23 Proximity sensor for T-slot, magneto-resistive – N/O contact				Technical data → 737				
	PNP, cable	★ 574335	SMT-8M-A-PS-24V-E-2,5-OE					
	PNP, plug	★ 574334	SMT-8M-A-PS-24V-E-0,3-M8D					
	PNP, plug	★ 574337	SMT-8M-A-PS-24V-E-0,3-M12					
	NPN, cable	★ 574338	SMT-8M-A-NS-24V-E-2,5-OE					
	NPN, plug	★ 574339	SMT-8M-A-NS-24V-E-0,3-M8D					
Magneto-resistive – N/C contact				Technical data → 737				
	PNP, cable	★ 574340	SMT-8M-A-PO-24V-E-7,5-OE					
Magnetic reed – N/O contact				Technical data → 732				
	Cable	★ 543862	SME-8M-DS-24V-K-2,5-OE					
	Cable	★ 543863	SME-8M-DS-24V-K-5,0-OE					
	Cable	★ 543872	SME-8M-ZS-24V-K-2,5-OE					
	Plug	★ 543861	SME-8M-DS-24V-K-0,3-M8D					
				Technical data → 734				
	Cable	★ 150855	SME-8-K-LED-24					
	Plug	150857	SME-8-S-LED-24					
Magnetic reed – N/C contact				Technical data → 734				
	Cable	160251	SME-8-O-K-LED-24					
24 Proximity sensor for C-slot, magneto-resistive – N/O contact				Technical data → 749				
	PNP, plug	★ 551375	SMT-10M-PS-24V-E-0,3-L-M8D					
	PNP, cable	★ 551373	SMT-10M-PS-24V-E-2,5-L-OE					
Magnetic reed – N/O contact				Technical data → 747				
	Plug	173212	SME-10-SL-LED-24					
	Cable	173210	SME-10-KL-LED-24					
				Technical data → 747				
				Technical data → 749				
Function	For Ø	Connection		Part No.	Type			
		Thread	O.D.					
25 One-way flow control valve with slotted head screw, metal¹⁾ for exhaust air flow control				Technical data → 609				
	10, 12, 16, 20	M5	3	★ 193137	GRLA-M5-QS-3-D			
	25		4	★ 193138	GRLA-M5-QS-4-D			
	32	G $\frac{1}{8}$	6	★ 193144	GRLA- $\frac{1}{8}$ -QS-6-D			
	40, 50, 63, 80		8	★ 193145	GRLA- $\frac{1}{8}$ -QS-8-D			
	100		8	★ 193147	GRLA- $\frac{1}{4}$ -QS-8-D			
For supply air flow control				Technical data → 609				
	10, 12, 16, 20	M5	3	★ 193153	GRLZ-M5-QS-3-D			
	25		4	★ 193154	GRLZ-M5-QS-4-D			
	32	G $\frac{1}{8}$	6	★ 193158	GRLZ- $\frac{1}{8}$ -QS-6-D			
	40, 50, 63, 80		8	★ 193159	GRLZ- $\frac{1}{8}$ -QS-8-D			

1) The recommended flow control valves are based on a tubing length to the valve of 1 m. For deviations of ±50%, flow control valves with a bigger or smaller flow rate must be selected to guarantee the optimum flow control function and cylinder speed.

Short-stroke cylinders ADVC

Dimensions

1 Without position sensing – Ø 4 ... 25 mm

ADVC-...-I-P – With female thread

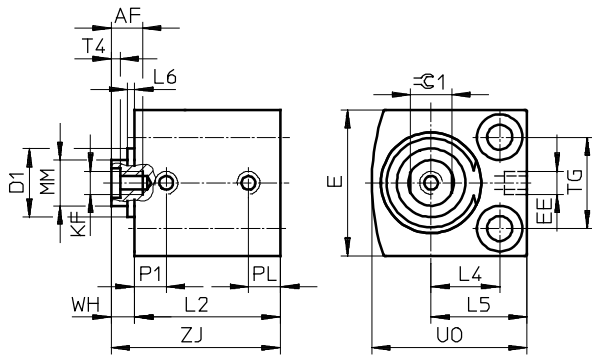

ADVC-...-A-P – With male thread

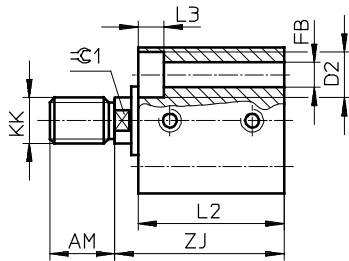

ADVC-...-P – Without thread

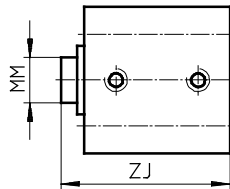

Note

Ø 4

Do not exceed the maximum screw-in depth of 3 mm and maximum tightening torque of 0.7 Nm.

Ø 10

The bearing cap can protrude up to 0.65 mm depending on the tolerance position.

Ø 12

The bearing cap can protrude up to 0.35 mm depending on the tolerance position.

Ø	Stroke	AF	AM	D1	D2	E	EE	FB	KF	KK	L2	L3
[mm]	[mm]	min.	-0.5	Ø max.	Ø	max.		Ø			+0.2	
4	2.5	-	6	-	3.3 ^{+0.1}	10	M3	1.8	-	M2	13	1.8
	5										15.5	
6	5	-	6	-	5 ^{+0.1}	13	M3	2.9	-	M3	16	2.9
	10										21	
10	5	-	8	7.5	5.8 ^{+0.1}	18	M5	3.4	-	M4	21	3.4
	10										24	
12	5	8	8	10.7	6 ^{H13}	20	M5	3.4	M3	M5	23	3.4
	10										28	
16	5	10	12	-	8 ^{H13}	25	M5	4.5	M4	M6	23	4.6
	10										28	
	15										33	
	20										38	
	25										43	
20	5	12	12	-	10 ^{H13}	32	M5	5.5	M5	M8	27	5.7
	10										32	
	15										37	
	20										42	
	25										47	
25	5	12	12	-	10 ^{H13}	38	M5	5.5	M5	M8	27.5	5.7
	10										32.5	
	15										37.5	
	20										42.5	
	25										47.5	

Dimensions

Download CAD data → www.festo.com

1

∅	Stroke	L4	L5	L6	MM	P1	PL	T4	TG	UO	WH	ZJ	≅C1
[mm]	[mm]			max.	∅				±0.1	max.		±0.8	
4	2.5	4	6.5	-	2	3.7	3.2	-	5.8	10	1	14	-
	5											16.5	
6	5	6	9	-	3	4.7	3	-	7	14	1	17	-
	10											22	
10	5	8	11.5	0.7	4	5.2	5.2	-	11	19	1.5	22.5	-
	10					6	5.5					25.5	
12	5	9	13	0.4	6	5.75	5.75	1.5	13	22	4	27	5
	10					9	6					32	
16	5	11.5	16.5	-	8	6	6	2	15	27	4	27	7
	10					32							
	15					37							
	20					42							
	25					47							
20	5	15	21	-	10	7.5	7	2	20	34	5	32	9
	10											37	
	15											42	
	20											47	
	25											52	
25	5	15.5	21.5	-	10	8	6.5	2	26	37	5	32.5	9
	10											37.5	
	15											42.5	
	20											47.5	
	25											52.5	

Short-stroke cylinders ADVC

Dimensions

1 Without position sensing – Ø 32 ... 100 mm

ADVC-...-I-P – With female thread

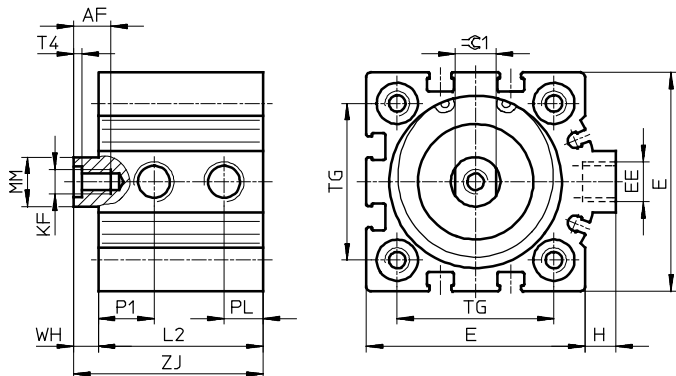

ADVC-...-A-P – With male thread

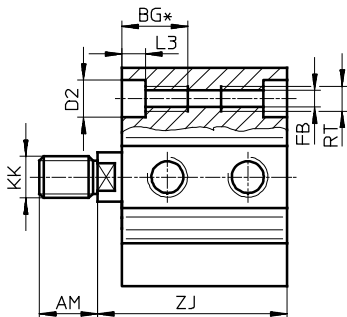

Ø	AF	AM	BG*	D2	E	EE	FB	H	KF	KK**
[mm]	min.	-0.5	min.	Ø F9	max.		Ø			
32	12	14	21.7	9	45	G1/8	5.2	7	M6	M10x1.25
40	12	14	21.7	9	53.5	G1/8	5.2	7	M6	M10x1.25
50	16	16	22.8	11	63.5	G1/8	6.8	7	M8	M12x1.25
63	16	16	22.8	11	75	G1/8	6.8	7.5	M8	M12x1.25
80	20	22	25	14	93	G1/8	8.5	7	M10	M16x1.5
100	24	28	25	14	113	G1/4	8.5	13	M12	M20x1.5

* Continuous thread with shorter sizes.
 ** Nut for piston rod thread included in the scope of delivery.

Dimensions

Download CAD data → www.festo.com

∅	Stroke	L2	L3	MM ∅	P1	PL	RT	T4	TG	WH	ZJ	⊖1
[mm]	[mm]	+0.2							±0.1		±0.8	
32	5	34	5.7	12	9	8.5	M6	2.6	32.5	6	40	10
	10	39									45	
	15	44									50	
	20	49									55	
	25	54									60	
40	5	34.5	5.7	12	11	9	M6	2.6	38	6	40.5	10
	10	39.5									45.5	
	15	44.5									50.5	
	20	49.5									55.5	
	25	54.5									60.5	
50	10	38	6.8	16	11.3	9.5	M8	3.3	46.5	8	46	13
	15	43									51	
	20	48									56	
	25	53									61	
63	10	45	6.8	16	12.5	11.5	M8	3.3	56.5	8	53	13
	15	50									58	
	20	55									63	
	25	60									68	
80	10	50	9	20	15	15	M10	4.7	72	8	58	17
	15	55									63	
	20	60									68	
	25	65									73	
100	10	59	9	25	16.5	19	M10	6.1	89	10	69	22
	15	64									74	
	20	69									79	
	25	74									84	

Short-stroke cylinders ADVC

Dimensions

1 With position sensing – Ø 6 ... 25 mm

ADVC-...-I-P-A – With female thread

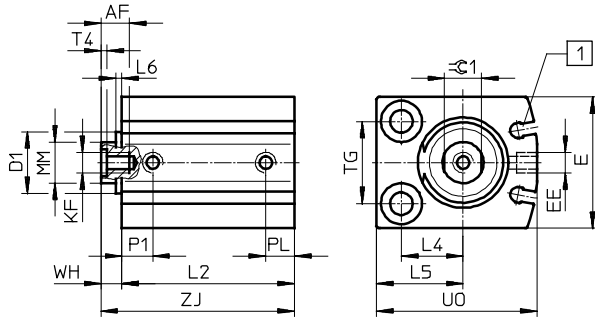

Note

Ø 10

The bearing cap can protrude up to 0.65 mm depending on the tolerance position.

Ø 12

The bearing cap can protrude up to 0.35 mm depending on the tolerance position.

1 Slot for proximity sensor
SME/SMT-10

ADVC-...-A-P-A – With male thread

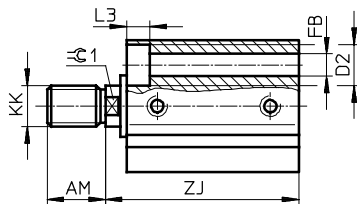

ADVC-...-P-A – Without thread

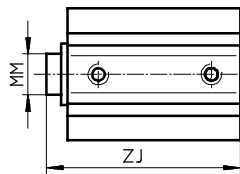

Ø [mm]	Stroke [mm]	AF min.	AM -0.5	D1 Ø max.	D2 Ø	E max.	EE	FB Ø	KF	KK	L2 +0.2	L3
6	5	-	6	-	5 +0.1	16	M3	2.9	-	M3	25.5	2.9
	10										30.5	
10	5	-	8	7.5	5.8 +0.1	21	M5	3.4	-	M4	27	3.4
	10										32	
12	5	8	8	10.7	6 H13	24	M5	3.4	M3	M5	36	3.4
	10										41	
16	5	10	12	-	8 H13	28	M5	4.5	M4	M6	35	4.6
	10										40	
	15										45	
	20										50	
	25										55	
20	5	12	12	-	10 H13	32	M5	5.5	M5	M8	37	5.7
	10										42	
	15										47	
	20										52	
	25										57	
25	5	12	12	-	10 H13	38	M5	5.5	M5	M8	37	5.7
	10										42	
	15										47	
	20										52	
	25										57	

Dimensions

Download CAD data → www.festo.com

∅ [mm]	Stroke [mm]	L4	L5	L6 max.	MM ∅	P1	PL	T4	TG ±0.1	UO max.	WH	ZJ ±0.8	≅1
6	5	5	8	-	3	5.2	3	-	10	16	1	26.5	-
	10											31.5	
10	5	7	10.5	0.7	4	6	6	-	14	22	1.5	28.5	-
	10											33.5	
12	5	8	12	0.4	6	7	6	1.5	16	26	4	40	5
	10											45	
16	5	12	17	-	8	8	6	2	18	32	4	39	7
	10											44	
	15											49	
	20											54	
	25											59	
20	5	15	21	-	10	7.5	7	2	20	39	5	42	9
	10											47	
	15											52	
	20											57	
	25											62	
25	5	15.5	21.5	-	10	10	6	2	26	42	5	42	9
	10											47	
	15											52	
	20											57	
	25											62	

Short-stroke cylinders ADVC

Dimensions

1 With position sensing – Ø 32 ... 100 mm

ADVC-...-I-P-A – With female thread

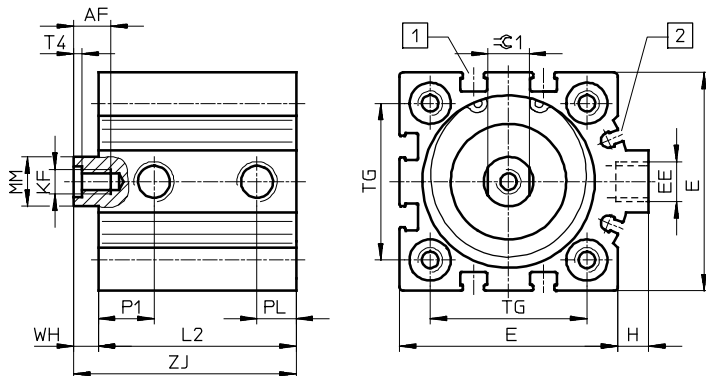

ADVC-...-A-P-A – With male thread

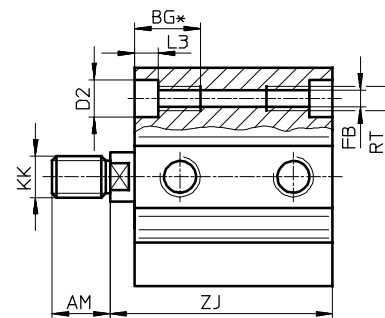

- 1 Slot for proximity sensor SME/SMT-8
- 2 Slot for proximity sensor SME/SMT-10

Ø [mm]	AF min.	AM -0.5	BG* min.	D2 Ø F9	E max.	EE	FB Ø	H	KF	KK**
32	12	14	21.7	9	45	G1/8	5.2	7	M6	M10x1.25
40	12	14	21.7	9	53.5	G1/8	5.2	7	M6	M10x1.25
50	16	16	22.8	11	63.5	G1/8	6.8	7	M8	M12x1.25
63	16	16	22.8	11	75	G1/8	6.8	7.5	M8	M12x1.25
80	20	22	25	14	93	G1/8	8.5	7	M10	M16x1.5
100	24	28	25	14	113	G1/4	8.5	13	M12	M20x1.5

* Continuous thread with shorter sizes.
 ** Nut for piston rod thread included in the scope of delivery.

Ø [mm]	Stroke [mm]	L2 +0.2	L3	MM Ø	P1	PL	RT	T4	TG ±0.1	WH	ZJ ±0.8	⊙1
32	5	38	5.7	12	9	8.5	M6	2.6	32.5	6	44	10
	10	43									49	
	15	48									54	
	20	53									59	
	25	58									64	
40	5	43	5.7	12	13.5	9.5	M6	2.6	38	6	49	10
	10	48									54	
	15	53									59	
	20	58									64	
	25	63									69	
50	10	48	6.8	16	11.3	9.5	M8	3.3	46.5	8	56	13
	15	53									61	
	20	58									66	
	25	63									71	
63	10	51	6.8	16	12.5	10.5	M8	3.3	56.5	8	59	13
	15	56									64	
	20	61									69	
	25	66									74	
80	10	59	9	20	15	8.5	M10	4.7	72	8	67	17
	15	64									72	
	20	69									77	
	25	74									82	
100	10	68	9	25	16.5	10.5	M10	6.1	89	10	78	22
	15	73									83	
	20	78									88	
	25	83									93	

Dimensions

Without position sensing – Ø 4 ... 25 mm

AEVC-...-I-P – With female thread

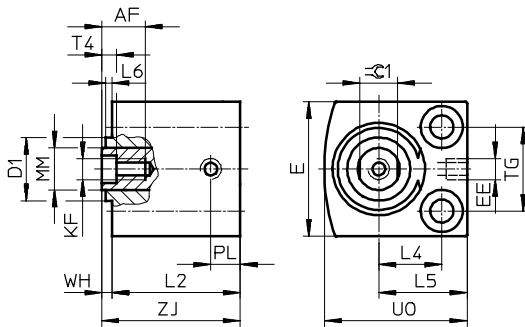

AEVC-...-A-P – With male thread

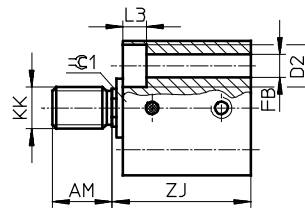

AEVC-...-P – Without thread

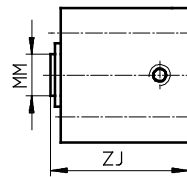

Note

Ø 10

The bearing cap can protrude up to 0.65 mm depending on the tolerance position.

Ø 12

The bearing cap can protrude up to 0.35 mm depending on the tolerance position.

Ø [mm]	Stroke [mm]	AF min.	AM -0.5	D1 Ø max.	D2 Ø	E max.	EE	FB Ø	KF	KK	L2 +0.2	L3
4	2.5	-	6	-	3.3 ^{+0.1}	10	M3	1.8	-	M2	13	1.8
	5										15.5	
6	5	-	6	-	5 ^{+0.1}	13	M3	2.9	-	M3	16	2.9
	10										23.4	
10	5	-	8	7.5	5.8 ^{+0.1}	18	M5	3.4	-	M4	16	3.4
	10										23	
12	5	8	8	10.7	6 H ¹³	20	M5	3.4	M3	M5	16	3.4
	10										27.5	
16	5	10	12	-	8 H ¹³	25	M5	4.5	M4	M6	20	4.6
	10										27.5	
	25										47	
20	5	8	12	-	10 H ¹³	32	M5	5.5	M5	M8	20	5.7
	10	12									30.5	
	25	12									48.5	
25	5	12	12	-	10 H ¹³	38	M5	5.5	M5	M8	26.1	5.7
	10										31.1	
	25										50.2	

Ø [mm]	Stroke [mm]	L4	L5	L6 max.	MM Ø	PL	T4	TG ±0.1	UO max.	WH	ZJ ±0.8	≈C1
4	2.5	4	6.5	-	2	3.2	-	5.8	10	1	14	-
	5										16.5	
6	5	6	9	-	3	3	-	7	14	1	17	-
	10										24.4	
10	5	8	11.5	0.7	4	5.5	-	11	19	1	17	-
	10										24	
12	5	9	13	0.4	6	6	1.5	13	22	1	17	-
	10										28.5	
16	5	11.5	16.5	-	8	6	2	15	27	1	21	7
	10										28.5	
	25										48	
20	5	15	21	-	10	7	2	20	34	1	21	9
	10										31.5	
	25										49.5	
25	5	15.5	21.5	-	10	6.5	2	26	37	1	27.1	9
	10										32.1	
	25										51.2	

Short-stroke cylinders AEVC

Dimensions

1 Without position sensing – Ø 32 ... 100 mm

AEVC-...-I-P – With female thread

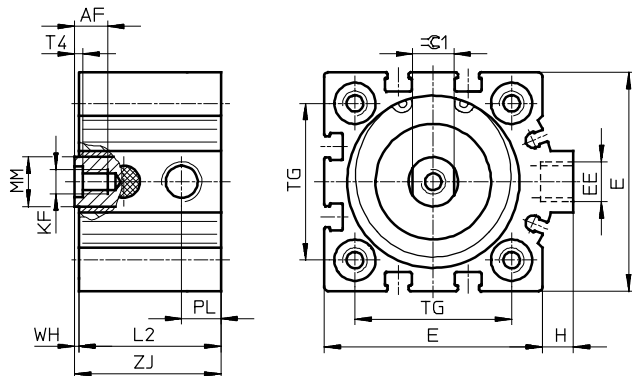

AEVC-...-A-P – With male thread

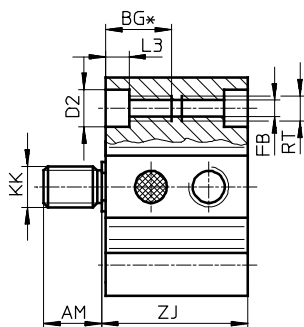

Ø	Stroke	AF	AM	BG*	D2	E	EE	FB	H	KF	KK**	L2	L3	MM	PL	RT	T4	TG	WH	ZJ	≈C1
[mm]	[mm]	min.	-0.5	min.	Ø F9	max.		Ø				+0.2		Ø				±0.1		±0.8	
32	5											26								27	10
	10	12	14	21.7	9	45	G $\frac{1}{8}$	5.2	7	M6	M10x1.25	35	5.7	12	9.5	M6	2.6	32.5	1	36	
	25											50								51	
40	10	12	14	21.7	9	53.5	G $\frac{1}{8}$	5.2	7	M6	M10x1.25	34.5	5.7	12	9.5	M6	2.6	38	1	35.5	10
	25											54.5								55.5	
50	10	16	16	22.8	11	63.5	G $\frac{1}{8}$	6.8	7	M8	M12x1.25	30.6	6.8	16	9.5	M8	3.3	46.5	0.5	31.1	13
	25											53								53.5	
63	10	16	16	22.8	11	75	G $\frac{1}{8}$	6.8	7.5	M8	M12x1.25	35	6.8	16	11.5	M8	3.3	56.5	1	36	13
	25											57								58	
80	10	20	22	25	14	93	G $\frac{1}{8}$	8.5	7	M10	M16x1.5	52	9	20	15	M10	4.7	72	1	53	17
	25											67								68	
100	10	24	28	25	14	113	G $\frac{1}{4}$	8.5	13	M12	M20x1.5	59	9	25	19	M10	6.1	89	1	60	22
	25											74								75	

* Continuous thread with shorter sizes.
 ** Nut for piston rod thread included in the scope of delivery.

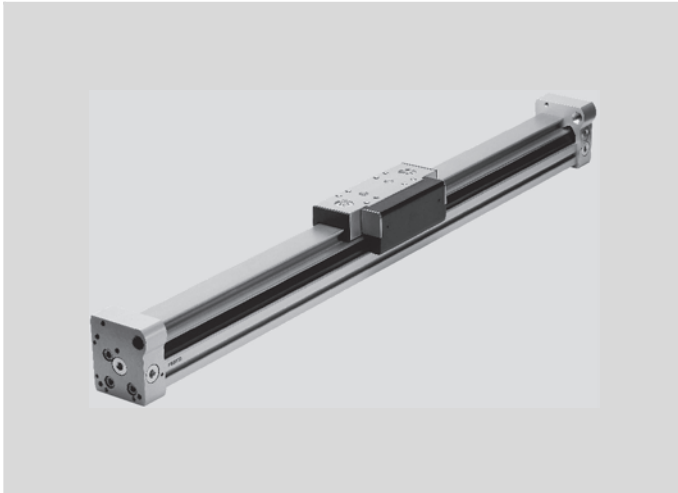

- Compact dimensions
- Quick and sturdy installation and mounting
- High precision and load carrying ability
- Excellent running characteristics and low air consumption
- Precision interfaces
- Many additional features
- Spare parts service

→ www.festo.com/catalogue/dgc

Product range overview

Type/function	Piston Ø [mm]	Stroke [mm]	Force [N]	Product options					→ Page/ online
				P	PPV	YSR	YSRW	A	
Double-acting	DGC-...-K – Compact design								
	18, 25, 32, 40, 50, 63, 80	1 ... 8,500	153 ... 3,016	–	■	–	–	■	dgc-k
	DGC-...-G – Basic design								
	8, 12, 18, 25, 32, 40, 50, 63	1 ... 8,500	30 ... 1,870	■	■	■	■	■	144
	DGC-...-GF – Plain-bearing guide								
	18, 25, 32, 40, 50, 63	1 ... 8,500	153 ... 1,870	–	■	■	■	■	147
DGC-...-KF – Recirculating ball bearing guide									
8, 12, 18, 25, 32, 40, 50, 63	1 ... 8,500	30 ... 1,870	■	■	■	■	■	150	
DGC-...-HD – Heavy-duty design									
18, 25, 40	10 ... 5,000	153 ... 754	–	–	■	■	■	172	
Without drive	DGC-FA – Passive guide axis								
	8, 12, 18, 25, 32, 40, 50, 63	1 ... 5,000	–	■	–	■	■	–	dgc-fa

Product options

N	NPT thread	YSRW	Self-adjusting shock absorber, progressive	H1	Lubrication approved for use in food applications	1H	Clamping unit
P	Elastic cushioning rings/pads at both ends	A	Position sensing	C	Lubrication adapter	PN	Pneumatically actuated clamping unit
PPV	Pneumatic cushioning, adjustable at both ends	DL	Supply port at the left end or at both ends	KL	Additional slide on left		
YSR	Self-adjusting shock absorber	GP	Protected recirculating ball bearing guide	KR	Additional slide on right		

Linear drives DGC-G, basic design

1 Technical data

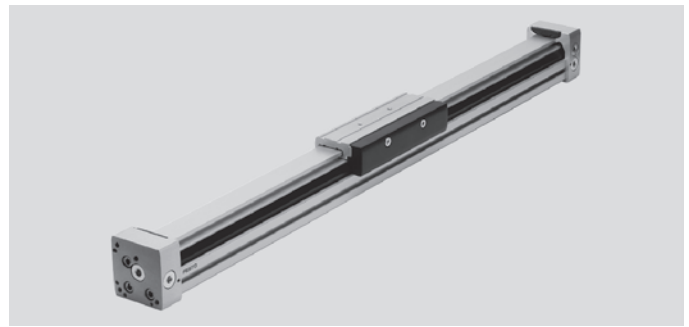
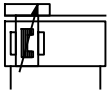

Technical data

Dimensions → 155

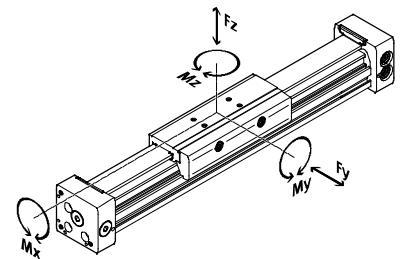

Piston Ø		8	12	18	25	32	40	50	63
Pneumatic connection		M5			G1/8		G1/4		G3/8
Stroke	[mm]	1 ... 1,500	1 ... 2,000	1 ... 3,000	1 ... 8,500			1 ... 5,000	
Cushioning	P	Elastic cushioning rings/pads at both ends			-				
	PPV	-			Pneumatic cushioning, adjustable at both ends				
	YSR...	Self-adjusting shock absorber at both ends			-				
Cushioning length ¹⁾	[mm]	-		16.5	15.5	17.5	29.5	29.8	31.1
Theoretical force at 6 bar	[N]	30	68	153	295	483	754	1,178	1,870
Max. permissible force F_y	[N]	150	300	70	180	250	370	480	650
Max. permissible force F_z	[N]	150	300	340	540	800	1,100	1,600	2,000
Max. permissible torque M_x	[Nm]	0.5	1.3	1.9	4	9	12	20	26
Max. permissible torque M_y	[Nm]	2	5	12	20	40	60	150	150
Max. permissible torque M_z	[Nm]	2	5	4	5	12	25	37	48

1) With PPV cushioning.

Operating conditions

Piston Ø		8	12	18	25	32	40	50	63
Operating pressure	[bar]	2.5 ... 8			2 ... 8		1.5 ... 8		
Ambient temperature ²⁾	[°C]	+5 ... +60		-10 ... +60					

2) Note operating range of proximity sensors.

Materials

Guide rail	Anodised aluminium
Slide	Anodised aluminium
End cap	Wrought aluminium alloy
Cylinder barrel	Anodised aluminium
Piston seal	TPE-U (PU)
Sealing band/cover strip:	TPE-U (PU)
Slide elements	PA

Order code

		DGC	-		-		-	G	-		-	A
Type												
DGC	Linear drive											
Piston Ø [mm]												
	Stroke [mm]											
8	1 ... 1,500											
12	1 ... 2,000											
18	1 ... 3,000											
25, 32, 40	1 ... 8,500											
50, 63	1 ... 5,000											
Guide												
G	Basic design											
Cushioning												
P	Elastic cushioning rings/ pads at both ends	1										
PPV	Pneumatic cushioning, adjustable at both ends	2										
YSR	Self-adjusting shock absorber at both ends	1										
YSRW	Self-adjusting, progressive shock absorber at both ends	1										
Position sensing												
A	Via proximity sensor											

1 Only with piston Ø 8 and 12 mm.

2 Not with piston Ø 8 and 12 mm.

Ordering – Product options

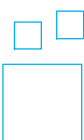
Configurable
productThis product and all its options can
be ordered using the configurator.The configurator can be found under
Products on the DVD or
→ www.festo.com/catalogue/...

Enter the type code in the search field.

Linear drives DGC-G, basic design

Accessories

1 DGC-8/-12

Note

1) Operation without cushioning components is not permitted.

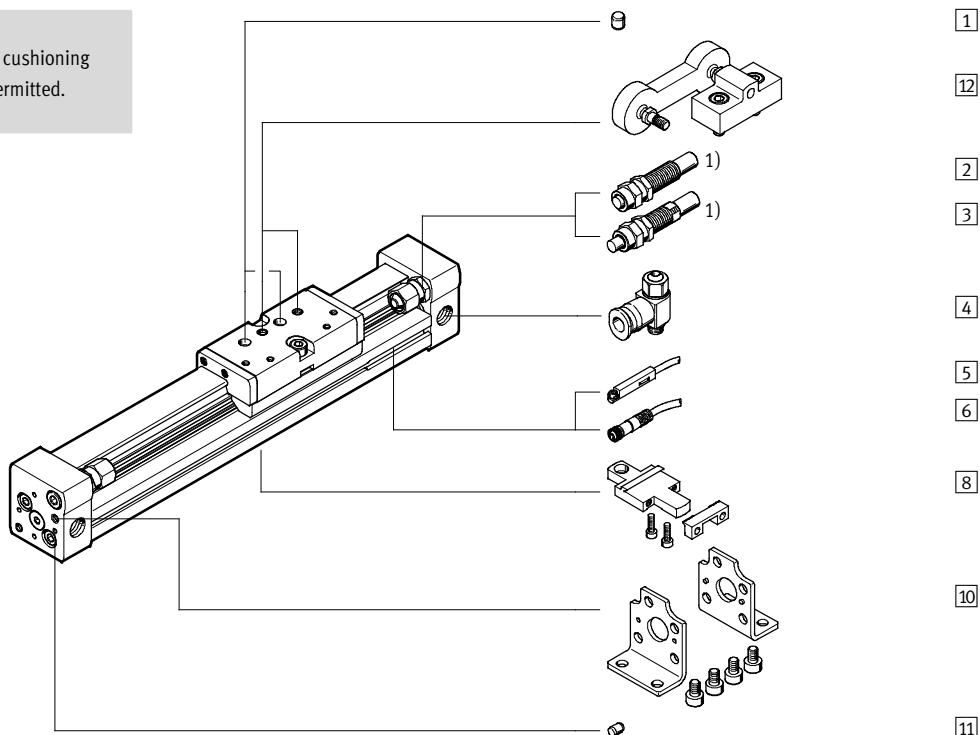

DGC-18 ... 63

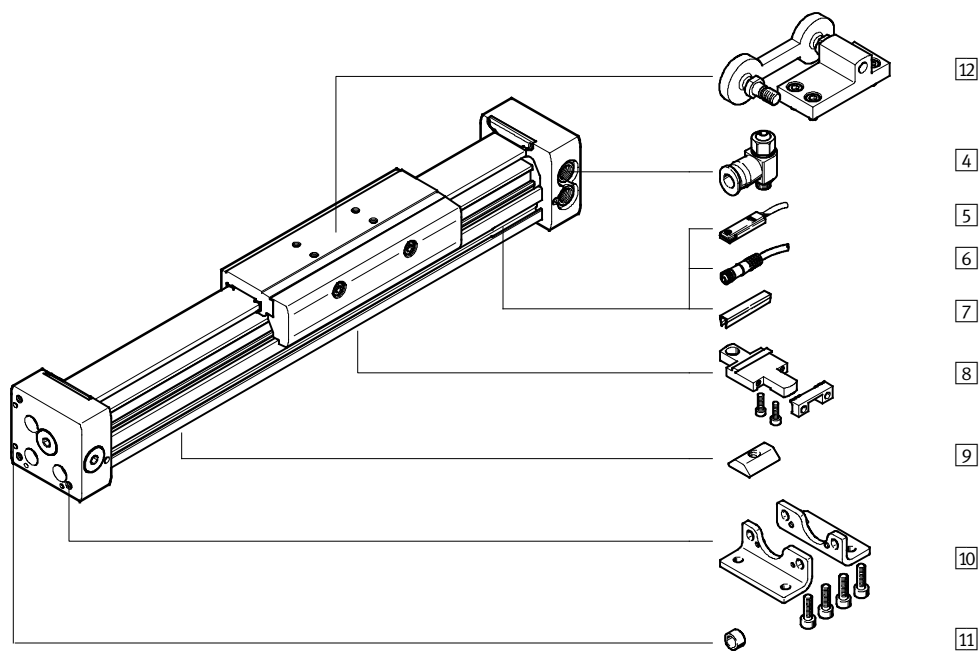

	→ Page/online
1 Centring pin ZBS ¹⁾	153
2 Shock absorber YSR	145
3 Shock absorber YSRW-DGC	153
4 One-way flow control valve GRLA	153
5 Proximity sensor SME/SMT	153
6 Connecting cable NEBU	154

	→ Page/online
7 Slot cover ABP-S	154
8 Profile mounting MUC	154
9 Slot nut HMBN	154
10 Foot mounting HPC	154
11 Centring pin/sleeve ZBS/ZBH	153
12 Moment compensator FKC	154

1) Included in the scope of delivery of the drive.

Technical data

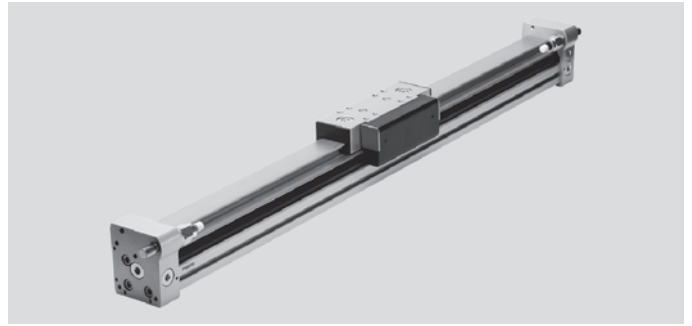
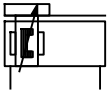

1

Technical data

Dimensions → 160

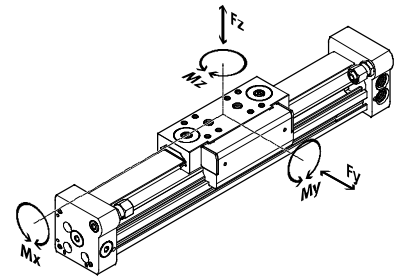

Piston Ø	18	25	32	40	50	63
Pneumatic connection	M5	G $\frac{1}{8}$		G $\frac{1}{4}$		G $\frac{3}{8}$
Stroke [mm]	1 ... 3,000		1 ... 8,500			1 ... 5,000
Cushioning	PPV	Pneumatic cushioning, adjustable at both ends				
	YSR...	Self-adjusting shock absorbers at both ends				
Cushioning length ¹⁾ [mm]	16.5	15.5	17.5	29.5	29.8	31.1
Theoretical force at 6 bar [N]	153	295	483	754	1,178	1,870
Max. permissible force F_y [N]	440	640	900	1,380	1,500	2,300
Max. permissible force F_z [N]	540	1,300	1,800	2,000	2,870	4,460
Max. permissible torque M_x [Nm]	3.4	8.5	15	28	54	96
Max. permissible torque M_y [Nm]	20	40	70	110	270	450
Max. permissible torque M_z [Nm]	8.5	20	33	54	103	187

1) With PPV cushioning.

Operating conditions						
Piston Ø	18	25	32	40	50	63
Operating pressure [bar]	2 ... 8			1.5 ... 8		
Ambient temperature ²⁾ [°C]	-10 ... +60					

2) Note operating range of proximity sensors.

Materials	
Guide rail	Anodised aluminium
Slide	Anodised aluminium
End cap	Anodised aluminium
Cylinder barrel	Anodised aluminium
Piston seal	TPE-U (PU)
Sealing band/cover strip:	TPE-U (PU)
Slide elements	PA

Linear drives DGC-GF, with plain-bearing guide

Order code

1

DGC		-		-		-	GF	-		-	A
Type											
DGC	Linear drive										
Piston Ø [mm]											
	Stroke [mm]										
18	1 ... 3,000										
25, 32, 40	1 ... 8,500										
50, 63	1 ... 5,000										
Guide											
GF	Plain-bearing guide										
Cushioning											
PPV	Pneumatic cushioning, adjustable at both ends										
YSR	Self-adjusting shock absorbers at both ends										
YSRW	Self-adjusting progressive shock absorbers at both ends										
Position sensing											
A	Via proximity sensor										

Ordering – Product options

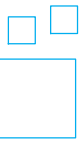

Configurable product

This product and all its options can be ordered using the configurator.

The configurator can be found under Products on the DVD or
 → www.festo.com/catalogue/...

Enter the type code in the search field.

Accessories

Note

1) Operation without cushioning components is not permitted.

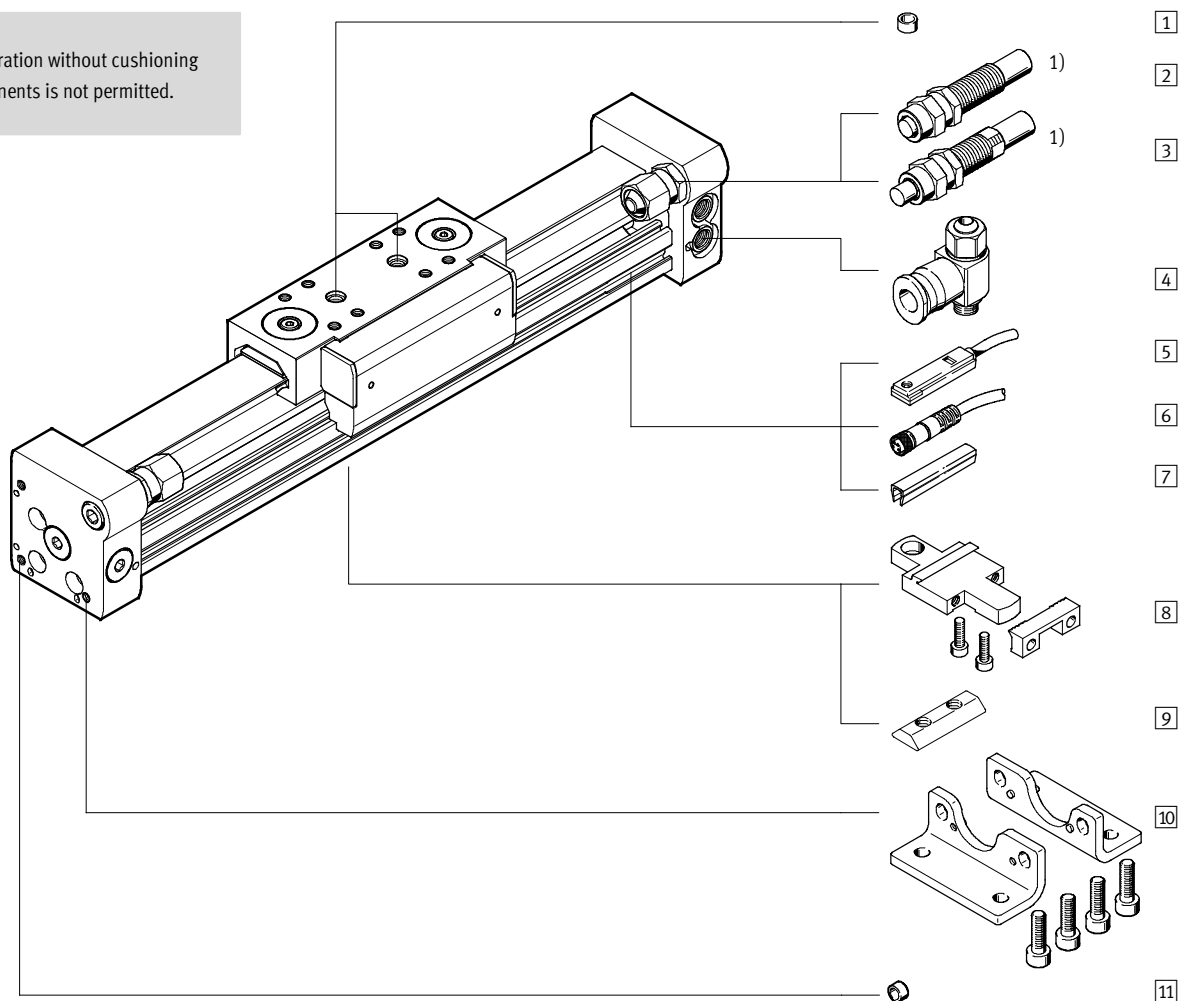

		→ Page/online
1	Centring pin/sleeve ZBS/ZBH ¹⁾	153
2	Shock absorber YSR	148
3	Shock absorber YSRW-DGC	153
4	One-way flow control valve GRLA	153
5	Proximity sensor SME-/SMT-8	154
6	Connecting cable NEBU	154
7	Slot cover ABP-S	154
8	Profile mounting MUC	154
9	Slot nut HMBN	154
10	Foot mounting HPC	154
11	Centring sleeve ZBH	153

1) Included in the scope of delivery of the axis.

Linear drives DGC-KF, with recirculating ball bearing guide

Technical data

1

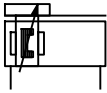

Technical data

Dimensions → 165

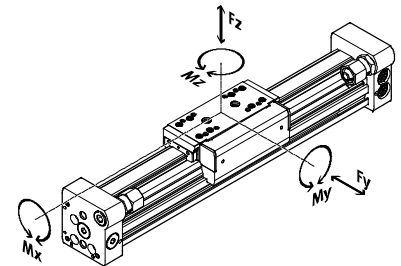

Piston Ø	8	12	18	25	32	40	50	63
Pneumatic connection	M5			G1/8		G1/4		G3/8
Stroke [mm]	1 ... 1,300	1 ... 1,900	1 ... 3,000	1 ... 8,500				
Cushioning	P	Elastic cushioning rings/pads at both ends		-				
	PPV	-		Pneumatic cushioning, adjustable at both ends				
	YSR...	Self-adjusting shock absorbers at both ends						
Cushioning length ¹⁾ [mm]	-		16.5	15.5	17.5	29.5	29.8	31.1
Theoretical force at 6 bar [N]	30	68	153	295	483	754	1,178	1,870
Max. permissible force F_y [N]	300	650	1,850	3,050	3,310	6,890	6,890	15,200
Max. permissible force F_z [N]	300	650	1,850	3,050	3,310	6,890	6,890	15,200
Max. permissible torque M_x [Nm]	1.7	3.5	16	36	54	144	144	529
Max. permissible torque M_y [Nm]	4.5	10	51	97	150	380	634	1,157
Max. permissible torque M_z [Nm]	4.5	10	51	97	150	380	634	1,157

1) With PPV cushioning.

Operating conditions

Piston Ø	8	15	18	25	32	40	50	63
Operating pressure [bar]	2.5 ... 8		2 ... 8			1.5 ... 8		
Ambient temperature ²⁾ [°C]	-10 ... +60							

2) Note operating range of proximity sensors.

Materials

Guide rail	High-alloy steel
Slide	High-alloy steel
End cap	Anodised aluminium
Cylinder barrel	Anodised aluminium
Piston seal	TPE-U (PU)
Sealing band/cover strip	TPE-U (PU)
Slide elements	PA

Order code

		DGC	-		-		-	KF	-		-	A
Type												
DGC	Linear drive											
Piston Ø [mm]												
	Stroke [mm]											
8	1 ... 1,300											
12	1 ... 1,900											
18	1 ... 3,000											
25, 32, 40	1 ... 8,500											
50, 63	1 ... 5,000											
Guide												
KF	Recirculating ball bearing guide											
Cushioning												
P	Elastic cushioning rings/ pads at both ends	1										
PPV	Pneumatic cushioning, adjustable at both ends	2										
YSR	Self-adjusting shock absorbers at both ends											
YSRW	Self-adjusting progressive shock absorbers at both ends											
Position sensing												
A	Via proximity sensor											

1 Only with piston Ø 8 and 12 mm.

2 Not with piston Ø 8 and 12 mm.

Ordering – Product options

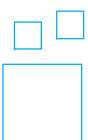
Configurable
productThis product and all its options can
be ordered using the configurator.The configurator can be found under
Products on the DVD or
→ www.festo.com/catalogue/...

Enter the type code in the search field.

Linear drives DGC-KF, with recirculating ball bearing guide

Accessories

1

Note

1) Operation without cushioning components is not permitted.

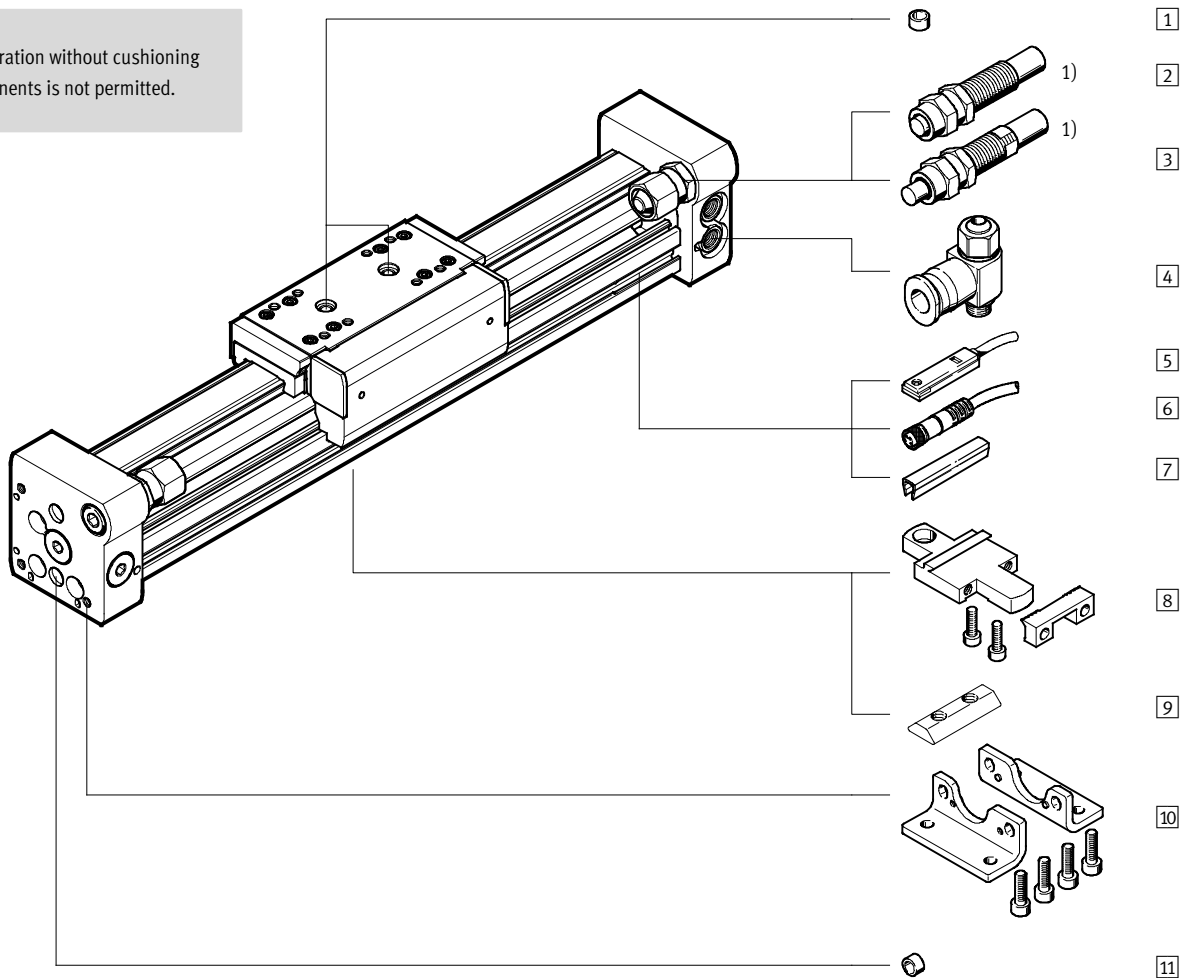

		→ Page/online
1	Centring pin/sleeve ZBS/ZBH ¹⁾	153
2	Shock absorber YSR	151
3	Shock absorber YSRW-DGC	153
4	One-way flow control valve GRLA	153
5	Proximity sensor SME-/SMT-8	154
6	Connecting cable NEBU	154
7	Slot cover ABP-S	154
8	Profile mounting MUC	154
9	Slot nut HMBN	154
10	Foot mounting HPC	154
11	Centring pin/sleeve ZBS/ZBH	153

1) Included in the scope of delivery of the axis.

Accessories – Ordering data

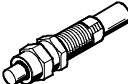

1

	For Ø	Description	Part No.	Type	
1	Centring pin/sleeve¹⁾				Technical data online: → zbh
	For DGC-G				
	8, 12	For slide	150928	ZBS-5	
	8, 12	For end cap	525273	ZBS-2	
	50, 63		150927	ZBH-9	
	For DGC-GF				
	18	For slide	150928	ZBS-5	
	25 ... 63		150927	ZBH-9	
	50, 63	For end cap	150927	ZBH-9	
	For DGC-KF				
	8, 12, 18	For slide	150928	ZBS-5	
	25 ... 63		150927	ZBH-9	
	8, 12	For end cap	525273	ZBS-2	
	18		150928	ZBS-5	
	25 ... 63		150927	ZBH-9	
	3	Shock absorber			
	For DGC-G				
	8		540344	YSRW-DGC-8	
	12		540345	YSRW-DGC-12	
	For DGC-GF				
	18		540346	YSRW-DGC-18-GF	
	25		540348	YSRW-DGC-25-GF	
	32		540350	YSRW-DGC-32-GF	
	40		540352	YSRW-DGC-40-GF	
	50		1232870	YSRW-DGC-40/50-B	
	63		543069	YSRW-DGC-63	
	For DGC-KF				
	18		540347	YSRW-DGC-18-KF	
	25		540349	YSRW-DGC-25-KF	
	32		540351	YSRW-DGC-32-KF	
	40		1232870	YSRW-DGC-40/50-B	
50		1232870	YSRW-DGC-40/50-B		
63		543069	YSRW-DGC-63		

1) Packaging unit 10 pieces.

	For Ø	Connection		Part No.	Type	
		Thread	O.D.			
4	One-way flow control valve with slotted head screw, metal²⁾				Technical data → 609	
	8, 12	M5	3	★ 193137	GRLA-M5-QS-3-D	
	18		6	★ 193139	GRLA-M5-QS-6-D	
	25, 32	G $\frac{1}{8}$	8	162966	GRLA- $\frac{1}{8}$ -QS-8-RS-B	
	40, 50			162968	GRLA- $\frac{1}{4}$ -QS-8-RS-B	
	63			162970	GRLA- $\frac{3}{8}$ -QS-8-RS-B	

2) The recommended flow control valves are based on a tubing length to the valve of 1 m. For deviations of ±50%, flow control valves with a bigger or smaller flow rate must be selected to guarantee the optimum flow control function and cylinder speed.

	For Ø		Part No.	Type	
5	Proximity sensor for C-slot for piston Ø 8/12, magneto-resistive – N/O contact				Technical data → 749
	PNP, cable	★	551373	SMT-10M-PS-24V-E-2,5-L-OE	
	PNP, plug	★	551375	SMT-10M-PS-24V-E-0,3-L-M8D	
Magnetic reed – N/O contact					Technical data → 747
	Cable		173210	SME-10-KL-LED-24	
	Plug		173212	SME-10-SL-LED-24	

Accessories – Ordering data

1

	For Ø		Part No.	Type	
5 Proximity sensor for T-slot for piston Ø 18 ... 63, magneto-resistive – N/O contact Technical data → 737					
	PNP, cable	★	574335	SMT-8M-A-PS-24V-E-2,5-OE	
	PNP, plug	★	574334	SMT-8M-A-PS-24V-E-0,3-M8D	
	PNP, plug	★	574337	SMT-8M-A-PS-24V-E-0,3-M12	
	NPN, cable	★	574338	SMT-8M-A-NS-24V-E-2,5-OE	
	NPN, plug	★	574339	SMT-8M-A-NS-24V-E-0,3-M8D	
Magneto-resistive – N/C contact Technical data → 737					
	PNP, cable	★	574340	SMT-8M-A-PO-24V-E-7,5-OE	
Magnetic reed – N/O contact Technical data → 732					
	Cable	★	543862	SME-8M-DS-24V-K-2,5-OE	
	Cable	★	543863	SME-8M-DS-24V-K-5,0-OE	
	Cable	★	543872	SME-8M-ZS-24V-K-2,5-OE	
	Plug	★	543861	SME-8M-DS-24V-K-0,3-M8D	
Technical data → 734					
	Cable	★	150855	SME-8-K-LED-24	
	Plug		150857	SME-8-S-LED-24	
Magnetic reed – N/C contact Technical data → 734					
	Cable		160251	SME-8-O-K-LED-24	
6 Connecting cable, straight socket Technical data → 949					
	2.5 m	★	541333	NEBU-M8G3-K-2.5-LE3	
	5.0 m	★	541334	NEBU-M8G3-K-5-LE3	
	2.5 m		541363	NEBU-M12G5-K-2.5-LE3	
	5.0 m		541364	NEBU-M12G5-K-5-LE3	
Angled socket Technical data → 949					
	2.5 m	★	541338	NEBU-M8W3-K-2.5-LE3	
	5.0 m	★	541341	NEBU-M8W3-K-5-LE3	
	2.5 m		541367	NEBU-M12W5-K-2.5-LE3	
	5.0 m		541370	NEBU-M12W5-K-5-LE3	

	For Ø		Part No.	Type
7 Slot cover¹⁾				
	18, 25, 32, 40, 50, 63		151680	ABP-5-S
8 Profile mounting Dimensions online: → dgc				
	8		526384	MUC-8
	12		526387	MUC-12
	18		531752	MUC-18
	25		531753	MUC-25
	32		531754	MUC-32
	40		531755	MUC-40
	50		531756	MUC-50
63		531757	MUC-63	
9 Slot nut²⁾ Dimensions online: → dgc				
	25, 32, 40		547264	HMBN-5-1M5
	50, 63		186566	HMBN-5-2M5

	For Ø		Part No.	Type
10 Foot mounting Dimensions online: → dgc				
	8		526385	HPC-8
	12		526388	HPC-12
	18		533667	HPC-18
	25		533668	HPC-25
	32		533669	HPC-32
	40		533670	HPC-40
	50		545236	HPC-50
63		545237	HPC-63	
12 Moment compensator Dimensions online: → dgc				
	8		529350	FKC-8/12
	12		529350	FKC-8/12
	18		538714	FKC-18
	25		538715	FKC-25
	32		538961	FKC-32
	40		538962	FKC-40
	50		545240	FKC-50/63
63		545240	FKC-50/63	

1) Packaging unit 2x 0.5 m.
2) Packaging unit 10 pieces.

Dimensions

Ø 8 ... 12

1

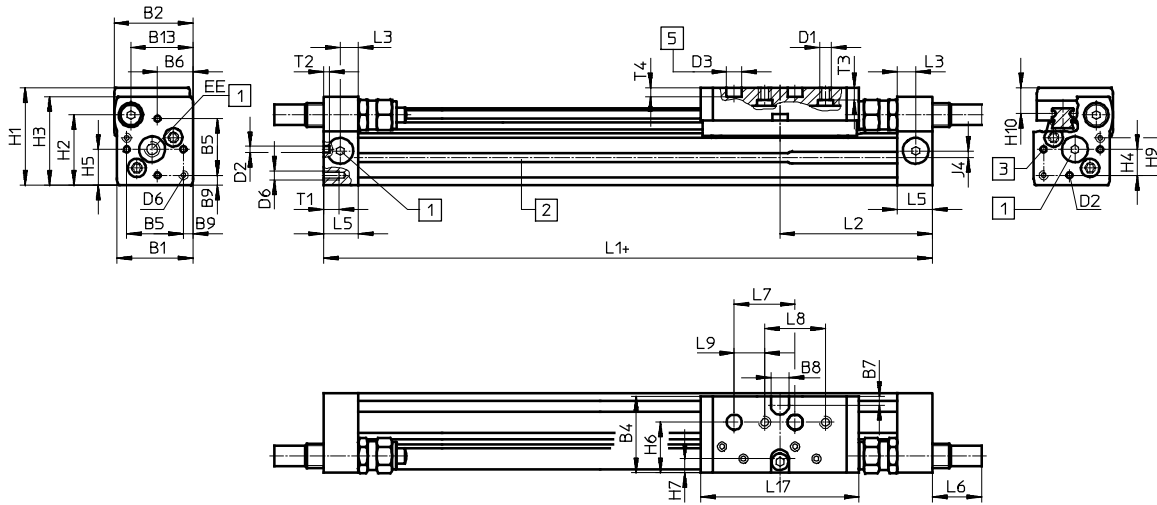

- 1 Supply port options on 3 sides
- 2 Slot for proximity sensor
- 3 Mounting hole for foot mounting or centring pin
- 5 Hole for centring pin ZBS + plus stroke length

Ø	B1	B2	B4	B5	B6	B7	B8	B9	B13	D1	D2	D3	D6
[mm]							±0.05	±0.1			Ø H8	Ø H7	
8	25	26	25.5	18.6	11.7	3	6	3.2	20.5	M4	2	5	M3
12	30.2	31	30.5	20.6	13.5	3	8	4.8	25	M4	2	5	M4

Ø	EE	H1	H2	H3	H4	H5	H6	H7	H9	H10	J4	L1	L2
[mm]													
8	M5	32	23	29	8.5	11.7	16.5	4.5	12.3	8.7	2.2	100	50.1
12	M5	37.5	28.5	34.5	8.7	13.5	20.5	5	14.7	9.8	3	125	62.1

Ø	L3	L5	L6			L7	L8	L9	L17	T1	T2	T3	T4	Stroke tolerance
			P	YSR	YSRW									
[mm]						±0.03	±0.1	±0.1					+0.2	
8	6	11.5	0	16	16.2	20	20	10	52	5	2	4	3	0 ... 1.7
12	8	16	0	11.3	12.3	20	20	10	65	6	2	5	3	

Profile

Ø 8

Ø 12

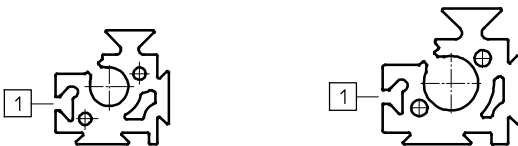

- 1 Slot for proximity sensor

Linear drives DGC-G, basic design

1 Ø 18 ... 40

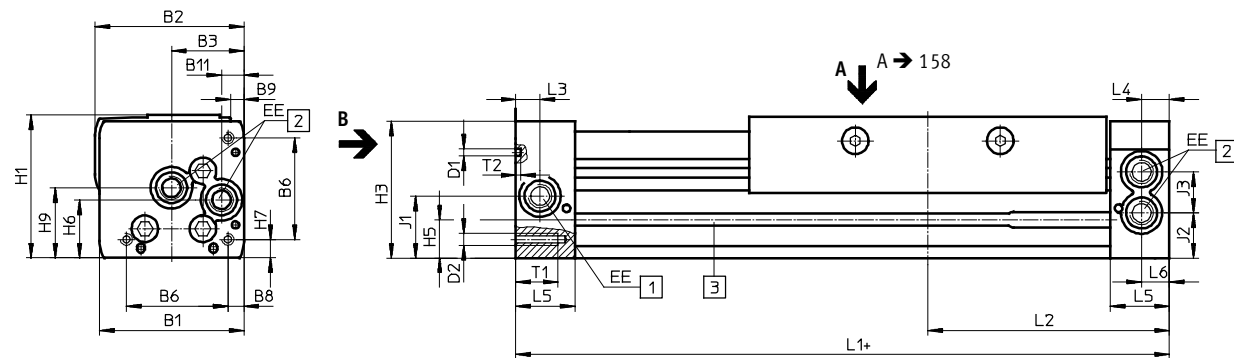

View B
Ø 18

Ø 25 ... 40

Ø 18 ... 40

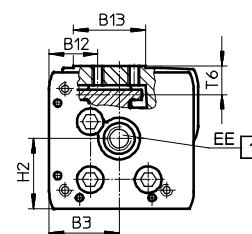
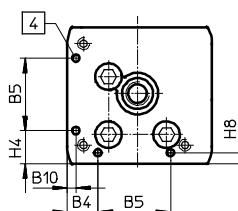
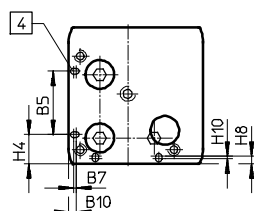

Ø 50/63

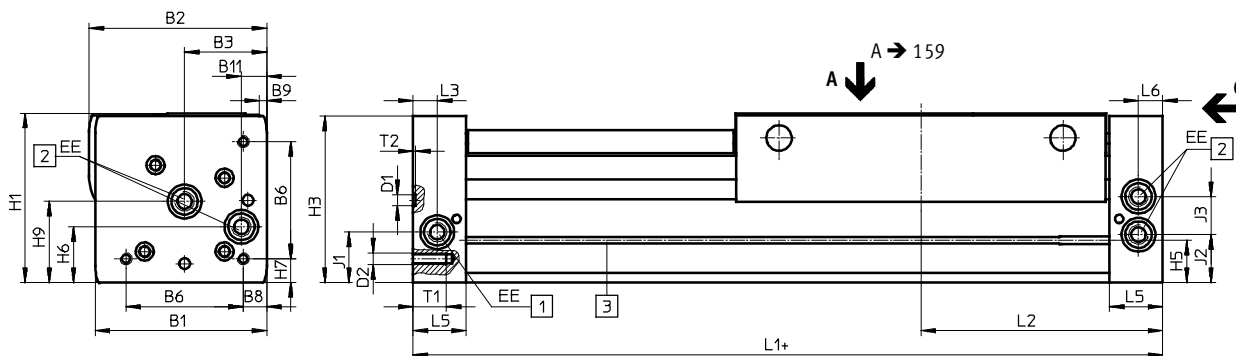

View C

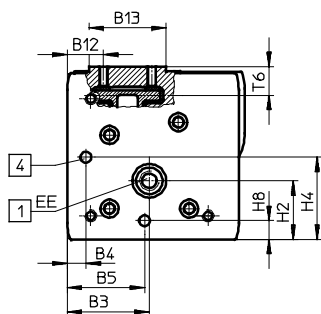

- + plus stroke length
- 1 Supply port options on 2 sides
- 2 Supply port options on 2 sides, for supply port at one end
- 3 Slot for proximity sensor
- 4 Mounting hole for foot mounting HPC

Dimensions

Download CAD data → www.festo.com

1

∅	B1	B2	B3	B4	B5	B6	B7	B8	B9	B10
[mm]					±0.05					
18	44.5	46.3	19.5	8.8	21	31	0.3	3.8	3.3	2.4
25	59.8	61.6	30	12.65	30	42		6.65	5.6	3.5
32	73	75.5	38.5	5.7	63.1	57.5		8.5	5	14
40	91	94.5	45	17.2	55	65		12.2	5.3	8
50	113	122	60	8	52.8	81.6	–	12	0	–
63	142	147	68	15.5	68	97	–	19.5	6	–

∅	B11	B12	B13	D1	D2	EE	H1	H2	H3	H4
[mm]				∅						±0.2
18	5.5	19.3	20	2±0.05	M4	M5	49.8	23.1	48.3	10.3
25	9.3	20.15	30	3±0.05	M5	G $\frac{1}{8}$	58.5	29	56.5	13
32	14.9	20.5	35	3±0.05	M6	G $\frac{1}{8}$	73	30	71.5	5.7
40	16.5	19.8	45	4±0.05	M6	G $\frac{1}{4}$	88	41.5	85	17.2
50	21	24	64	9 ^{H7}	M8	G $\frac{1}{4}$	120	38.5	116	52.8
63	21	30	64	9 ^{H7}	M10	G $\frac{3}{8}$	140	48.5	137.5	68

∅	H5	H6	H7	H8	H9	H10	J1	J2	J3	L1
[mm]										
18	13.4	20	5.3	2.4	25.2	0.4	20	16.5	11	150
25	15.8	24	7	4.5	29		26.1	18.6	17	200
32	17	27.7	8.5	14	35.2		30	22	18.5	250
40	25	36.5	12.2	8	44		35	26	26	300
50	29.3	36	12	8	53	–	30.5	30.5	28	350
63	34.8	46	19.5	15.5	67	–	41.5	39.5	31.5	400

∅	L2	L3	L4	L5	L6	T1	T2	T6	Stroke tolerance
[mm]									
18	74.5	5.7	5.8	15	5.5	9	2	10.7	0 ... 2.5
25	100	10.5	10.6	24.5	10.6	17.5	2	12	
32	124.8	14.5	14.5	30.5	14.5	15	2	13.8	
40	150	14.6	14.6	33.5	14.6	20	3	16.8	
50	175	17	–	41	17	24	2.1 ^{+0.2}	20.75	
63	200	20	–	44	20	27.5	2.1 ^{+0.2}	20.75	

• Note: This product conforms to ISO 1179-1 and ISO 228-1.

Linear drives DGC-G, basic design

1 Dimensions

Slide – View A

Ø 18

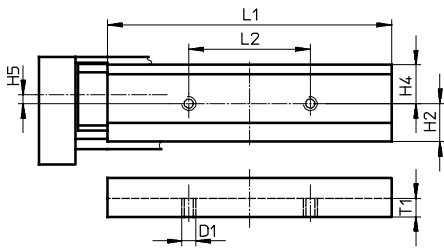

Ø 25

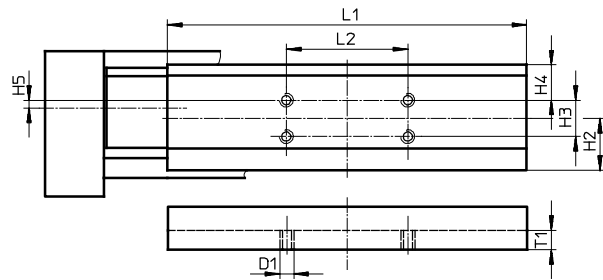

Ø 32

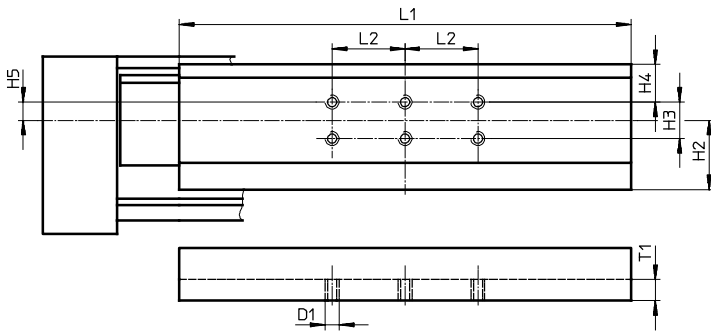

Ø 40

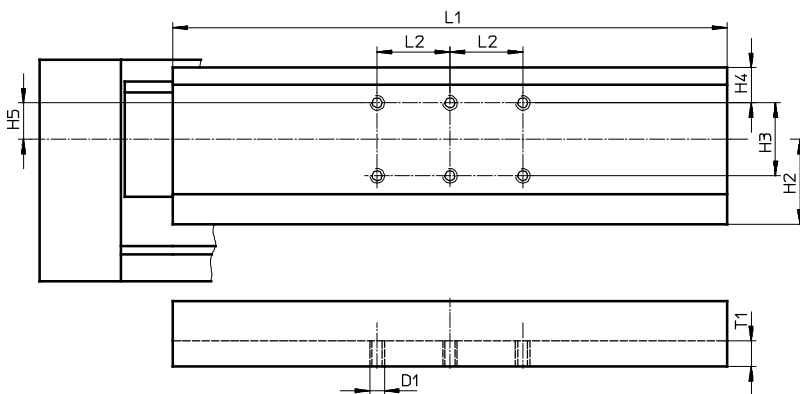

Ø 50

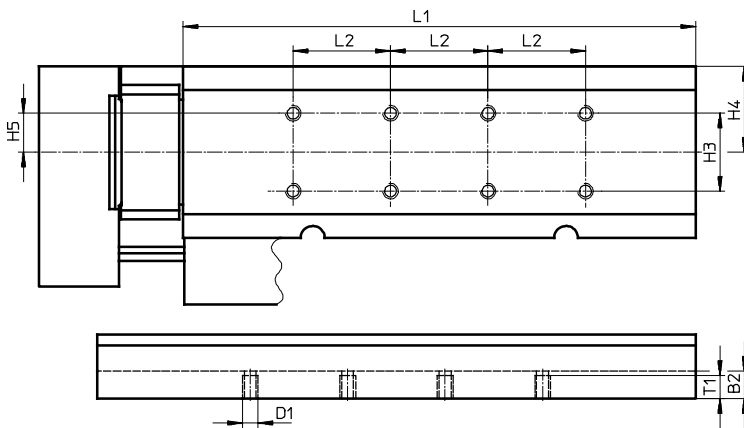

Dimensions

Slide – View A

∅ 63

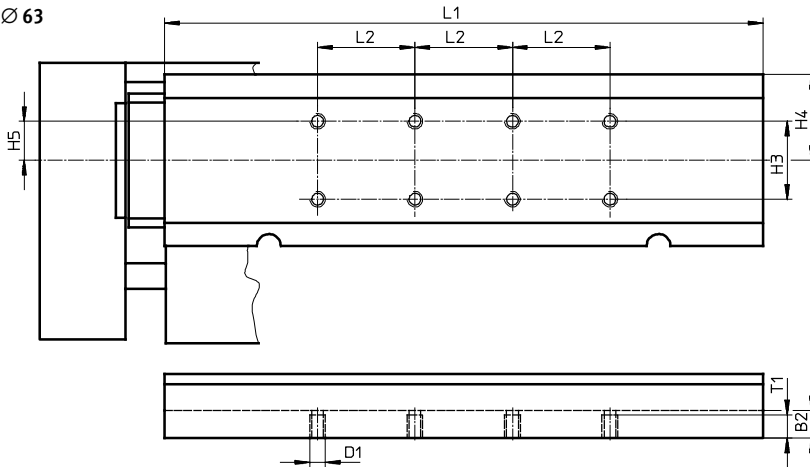

∅	B2	D1	H2	H3	H4	H5	L1	L2	T1
[mm]			±0.1	±0.1				±0.1	
18	-	M5	15.6	-	16	2	117±0.05	50	7
25	-	M5	21.35	15	14.55	4.85	148±0.05	50	8
32	-	M5	28.5	15	15.5	7.5	186±0.05	30	8.6
40	-	M6	35	30	14.5	15	228±0.05	30	10.5
50	14	M8	-	40	44	20	263±0.1	50	13
63	14	M8	-	40	44	20	307±0.1	50	13

Profile barrel

∅ 18

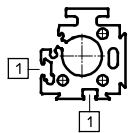

∅ 25

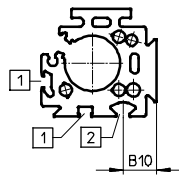

∅ 32

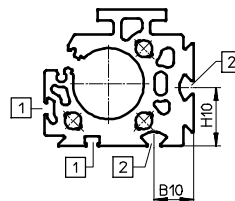

∅ 40

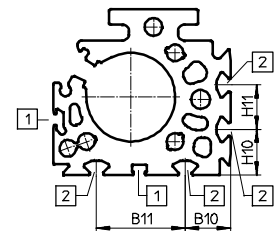

∅ 50

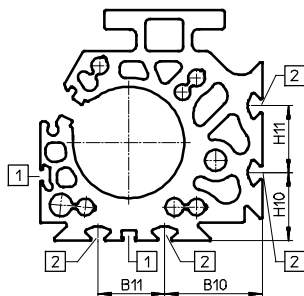

∅ 63

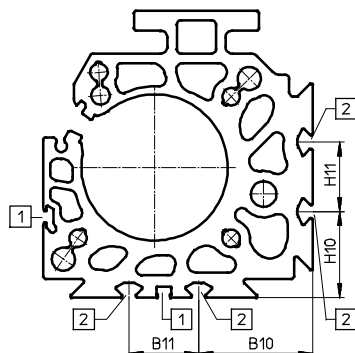

- 1 Slot for proximity sensor
- 2 Mounting slot for slot nut

∅	B10	B11	H10	H11
[mm]				
25	15.23	-	-	-
32	18	-	26.5	-
40	20.5	40	20.5	20
50	43.8	30	30.5	30
63	49	30	37	30

Linear drives DGC-GF, with plain-bearing guide

Dimensions

1 Ø 18 ... 40

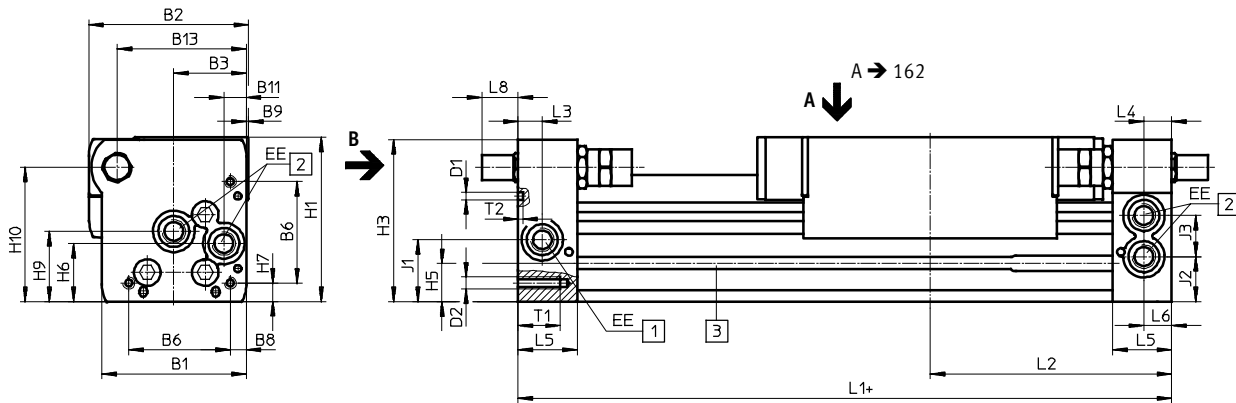

View B
Ø 18

Ø 25 ... 40

Ø 18 ... 40

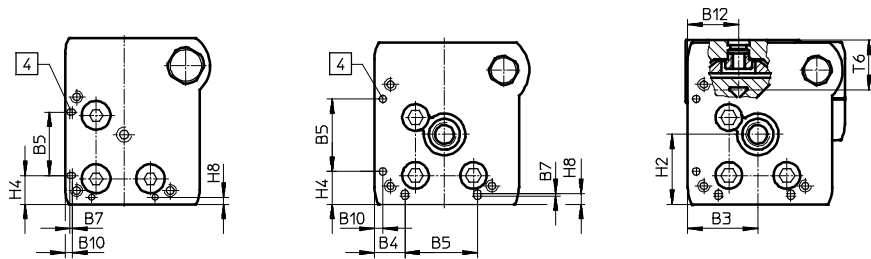

- + = plus stroke length
- 1 Supply port options on 2 sides
- 2 Supply port options on 2 sides, for supply port at one end
- 3 Slot for proximity sensor
- 4 Mounting hole for foot mounting HPC

Ø	B1	B2	B3	B4	B5	B6	B7	B8	B9	B10	B11
[mm]					±0.05						
18	44.5	49.9	19.5	8.8	21	31	0.8	3.8	1	2.4	5.5
25	59.8	66	30	12.65	30	42	1	6.65	1	3.5	9.3
32	73	79	38.5	5.7	63.1	57.5	-	8.5	1.5	14	14.9
40	91	98.5	45	17.2	55	65	-	12.2	2	8	16.5

Ø	B12	B13	D1	D2	EE	H1	H2	H3	H4	H5	H6
[mm]			±0.05						±0.2		
18	15.5	39	2	M4	M5	56.3	23.1	55	9.6	13.4	20
25	21	53.5	3	M5	G1/8	68	29	67	13.65	15.8	24
32	18	66.5	3	M6	G1/8	78.5	30	77	5.7	17	27.7
40	24.8	80.5	4	M6	G1/4	99.5	41.5	97.5	17.2	25	36.5

Ø	H7	H8	H9	H10	J1	J2	J3	L1	L2	L3	L4
[mm]											
18	4.6	2.4	25.2	46	20	16.5	11	150	74.5	5.7	5.8
25	7.65	4.5	29	55.5	26.1	18.6	17	200	100	10.5	10.6
32	8.5	14	35.2	63.8	30	22	18.5	250	124.8	14.5	14.5
40	12.2	8	44	81.5	35	26	26	300	150	14.6	14.6

Ø	L5	L6	L8			T1	T2	T6	Stroke tolerance
			PPV	YSR	YSRW				
[mm]									
18	15	5.5	0	15.9	19.4	9	2	17.1	0 ... 2.5
25	24.5	10.6	0	12.5	15	17.5	2	20.5	
32	30.5	14.5	0	8.5	15.5	15	2	21.3	
40	33.5	14.6	0	12.8	21	20	3	30.7	

Dimensions

∅ 50/63

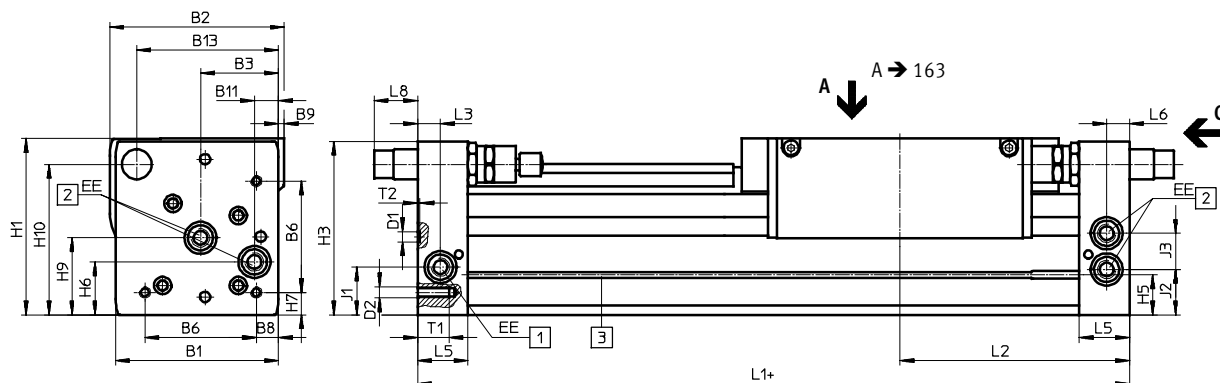

View C

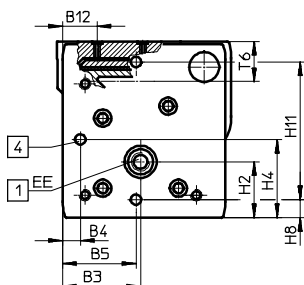

- + plus stroke length
- 1 Supply port options on 2 sides
- 2 Supply port options on 2 sides, for supply port at one end
- 3 Slot for proximity sensor
- 4 Mounting hole for foot mounting HPC

∅	B1	B2	B3	B4	B5	B6	B8	B9	B11	B12	B13	D1	D2
[mm]					±0.05							∅ H7	
50	113	126.5	60	8	52.8	81.6	12	–	21	24	97	9	M8
63	142	149	68	15.5	68	97	19.5	5	21	30	123.5	9	M10

∅	EE	H1	H2	H3	H4	H5	H6	H7	H8	H9	H10	H11	J1
[mm]												±0.05	
50	G1/4	124.5	38.5	122.5	52.8	29.3	36	12	8	53	104.5	100	30.5
63	G3/8	153.5	48.5	151	68	34.8	46	19.5	15.5	67	131	120	41.5

∅	J2	J3	L1	L2	L3	L5	L6	L8			T1	T2	T6	Stroke tolerance
								PPV	YSR	YSRW				
[mm]												+0.2		
50	30.5	28	350	175	17	41	17	0	31	36.3	24	2.1	30.4	0 ... 2.5
63	39.5	31.5	400	200	20	44	20	0	38.3	48.3	27.5	2.1	36.2	

Note: This product conforms to ISO 1179-1 and ISO 228-1.

Linear drives DGC-GF, with plain-bearing guide

1

Dimensions

Slide

Ø 18

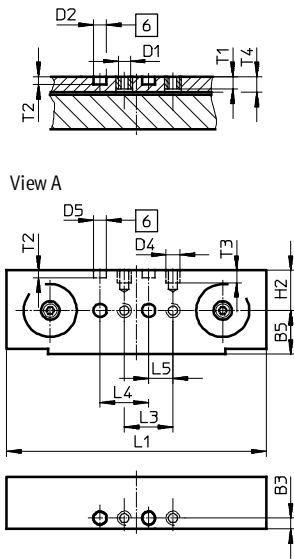

Ø 25

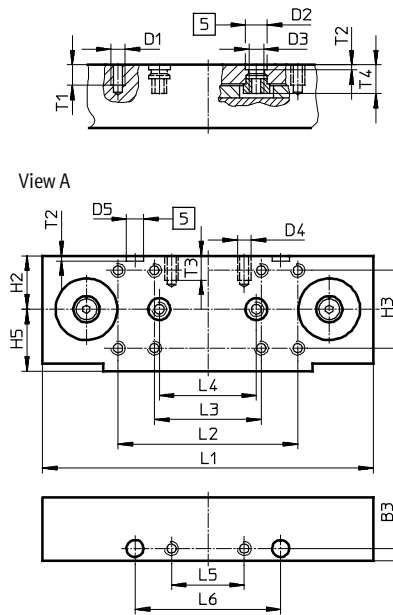

Ø 32

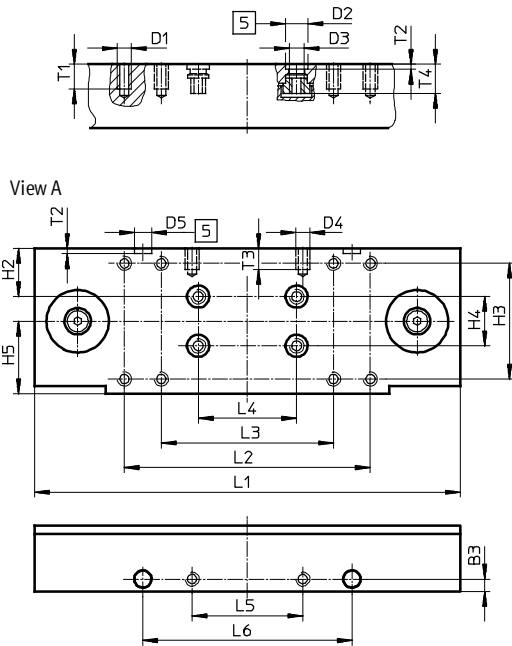

Ø 40

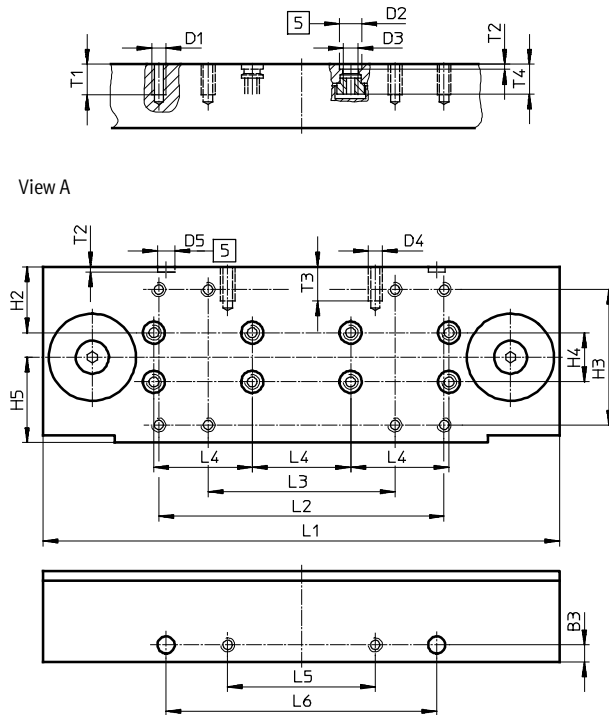

- 5 Hole for centring sleeve ZBH
- 6 Hole for centring pin ZBS

Dimensions

Slide

Ø 50

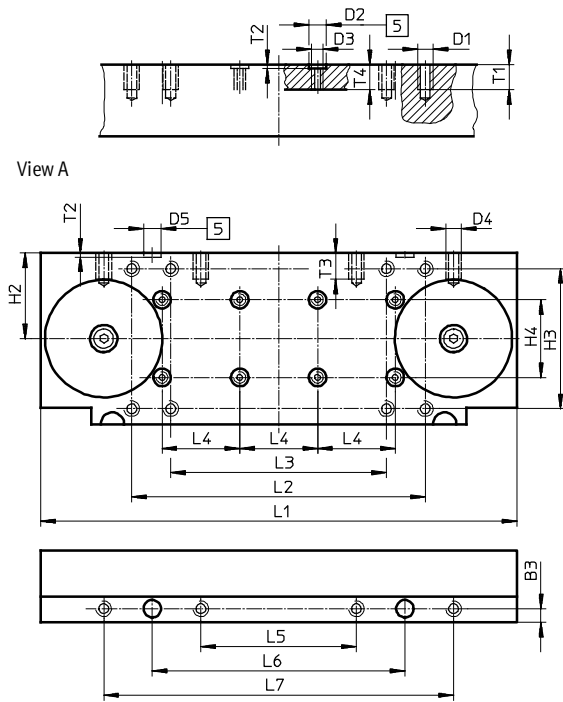

Ø 63

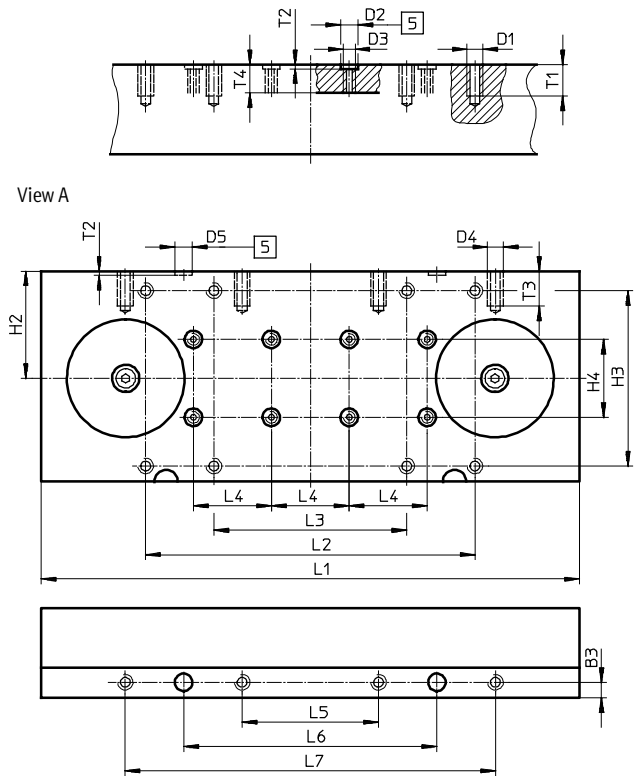

5 Hole for centring sleeve ZBH

Ø	B3	D1	D2	D3	D4	D5	H2	H3	H4	H5	L1
[mm]	±0.05		Ø H7			Ø H7			±0.03	±0.1	±0.1
18	4.5	M5	5	-	M5	5	16.5	-	-	18	107
25	5	M5	9	M6	M5	7	22	32±0.2	-	25.5	136
32	5	M5	9	M6	M5	7	19.5	47±0.2	20	29.5	173
40	7	M5	9	M6	M6	7	26.8	55±0.2	20	34.7	210
50	7	M8	9	M6	M8	9	44	72±0.3	40	-	245
63	8	M8	9	M6	M8	9	55	90±0.3	40	-	276

Ø	L2	L3	L4	L5	L6	L7	T1	T2	T3	T4
[mm]	±0.1		±0.03	±0.1	±0.05	±0.1				
18	-	20±0.1	20	10	-	-	5	3.1±0.1	5	6.3
25	74	44±0.2	40	30	60	-	8.5	2.1±0.2	10	11.8
32	100	70±0.2	40	45	85	-	10	2.1±0.2	8.5	11.8
40	116	76±0.2	40	60	110	-	12.5	2.1±0.2	14	12.1
50	151	111±0.2	40	80	130	180	13	2.1±0.2	13.5	13
63	169	99±0.2	40	70	130	190	16	2.1±0.2	18	14.5

Linear drives DGC-GF, with plain-bearing guide

Dimensions

1 Profile barrel

Ø 18

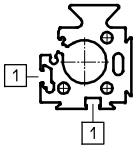

Ø 25

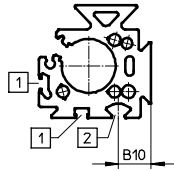

Ø 32

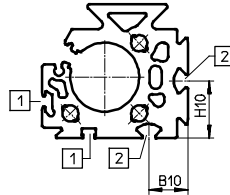

Ø 40

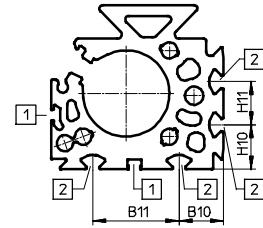

Ø 50

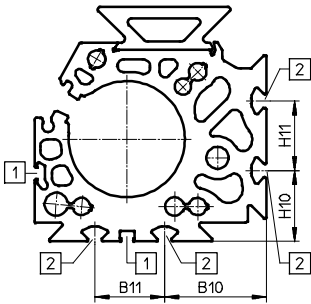

Ø 63

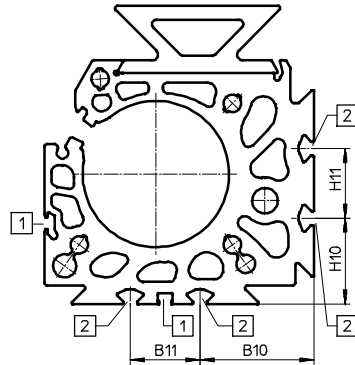

- 1 Slot for proximity sensor
- 2 Mounting slot for slot nut

Ø	B10	B11	H10	H11
25	15.23	-	-	-
32	18	-	26.5	-
40	20.5	40	20.5	20
50	43.8	30	30.5	30
63	49	30	37	30

Linear drives DGC-KF, with recirculating ball bearing guide

Dimensions

Ø 8 ... 12

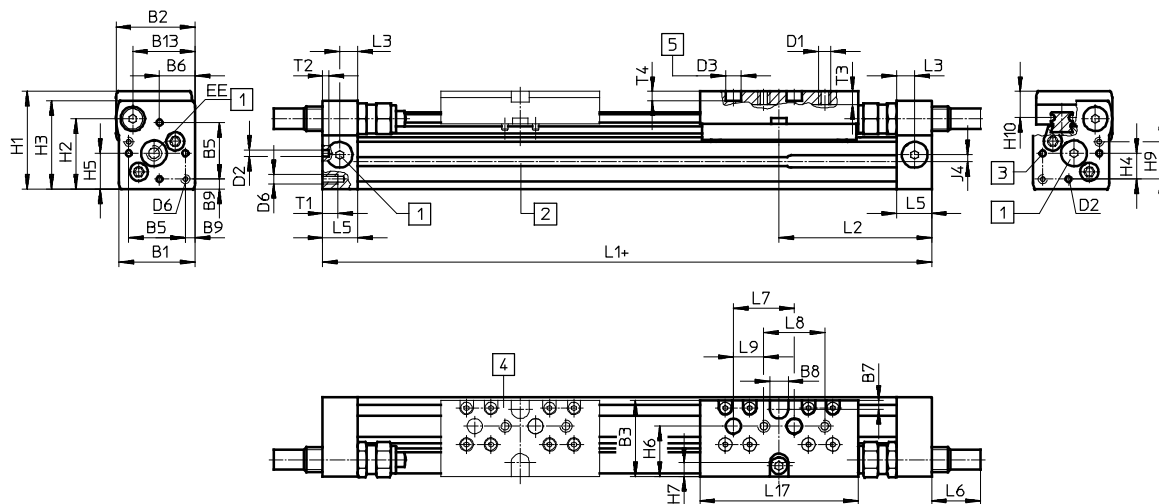

- 1 Supply port options on 3 sides
- 2 Slot for proximity sensor
- 3 Mounting hole for foot mounting or centring pin
- 4 Additional slide KL
- 5 Hole for centring pin ZBS
- + plus stroke length

Ø	B1	B2	B3	B5	B6	B7	B8	B9	B13	D1	D2	D3	D6
[mm]							±0.05	±0.1			Ø H8	Ø H7	
8	25	26	25	18.6	11.7	3	6	3.2	20.5	M4	2	5	M3
12	30.2	31	31	20.6	13.5	3	8	4.8	25	M4	2	5	M4

Ø	EE	H1	H2	H3	H4	H5	H6	H7	H9	H10	J4	L1	L2
[mm]													
8	M5	32	23	29	8.5	11.7	16.5	4.5	12.3	8.7	2.2	100	50.1
12	M5	37.5	28.5	34.5	8.7	13.5	20.5	5	14.7	9.8	3	125	62.1

Ø	L3	L5	L6			L7	L8	L9	L17	T1	T2	T3	T4	Stroke tolerance
			P	YSR	YSRW									
[mm]						±0.03	±0.1	±0.1					+0.2	
8	6	11.5	0	16	16.2	20	20	10	52	5	2	4.3	3	0 ... 1.7
12	8	16	0	11.3	12.3	20	20	10	65	6	2	5	3	

Profile barrel

Ø 8

Ø 12

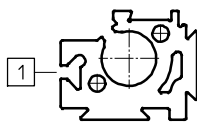
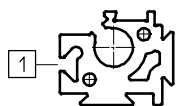

- 1 Slot for proximity sensor

Linear drives DGC-KF, with recirculating ball bearing guide

1 Dimensions

Ø 18 ... 40

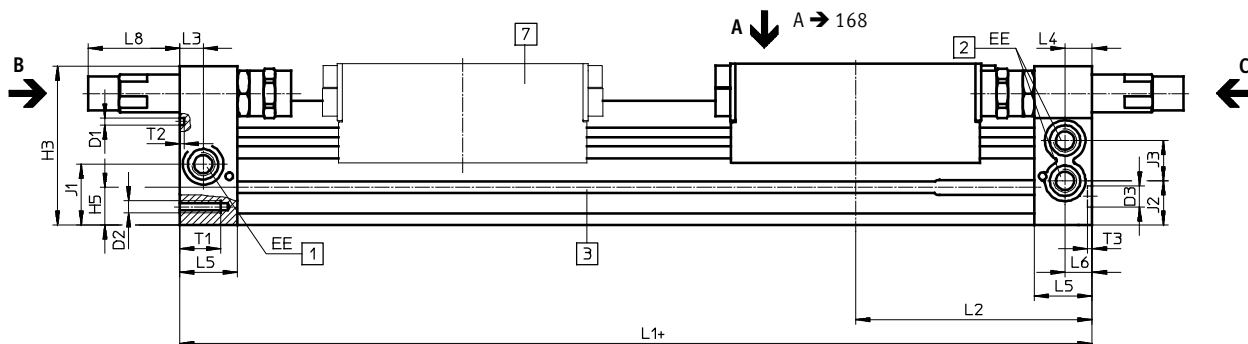

View C

Ø 18 ... 40

View B

Ø 18

Ø 25 ... 40

Ø 18 ... 40

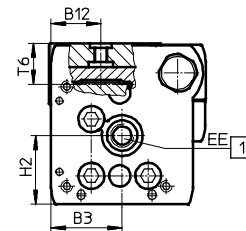
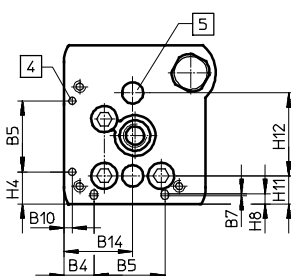
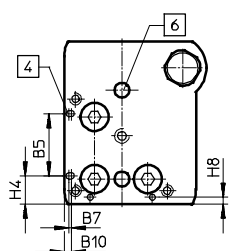
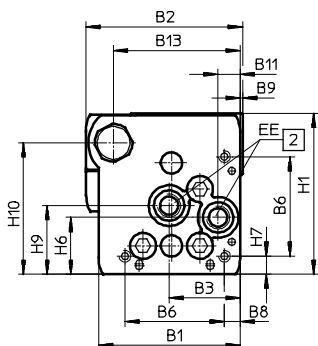

Ø 50/63

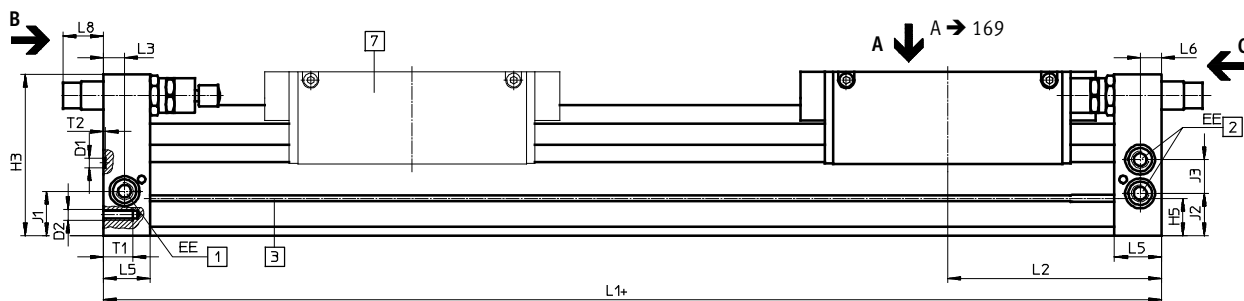

View C

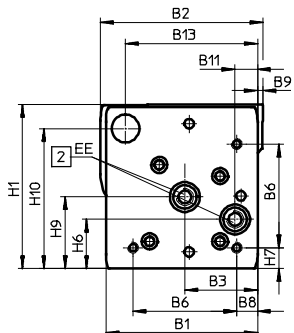

View B

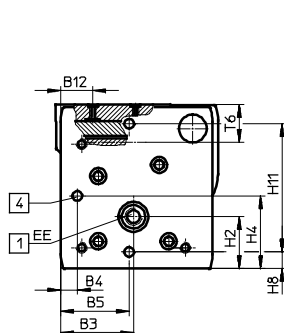

- + = plus stroke length
- 1 Supply port options on 2 sides
- 2 Supply port options on 2 sides, for supply port at one end
- 3 Slot for proximity sensor
- 4 Mounting hole for foot mounting HPC
- 5 Hole for centring sleeve ZBH
- 6 Hole for centring pin ZBS
- 7 Additional slide

Linear drives DGC-KF, with recirculating ball bearing guide

FESTO

Dimensions

Download CAD data → www.festo.com

1

∅	B1	B2	B3	B4	B5	B6	B7	B8	B9	B10	B11	B12
[mm]					±0.05							
18	44.5	49.9	19.5	8.8	21	31	0.8	3.8	1	2.4	5.5	15.5
25	59.8	66	30	12.65	30	42	1	6.65	1	3.5	9.3	21
32	73	79	38.5	5.7	63.1	57.5	–	8.5	1.5	14	14.9	18
40	91	98.5	45	17.2	55	65	–	12.2	2	8	16.5	24.8
50	113	126.5	60	8	52.8	81.6	–	12	–	–	21	24
63	142	149	68	15.5	68	97	–	19.5	5	–	21	30

∅	B13	B14	D1	D2	D3	EE	H1	H2	H3	H4	H5	H6
[mm]			∅		∅					±0.2		
18	39	19.5	2±0.05	M4	5	M5	56.3	23.1	55	9.6	13.4	20
25	53	29	3±0.05	M5	9	G1/8	68	29	67	13.65	15.8	24
32	65	38.5	3±0.05	M6	9	G1/8	78.5	30	77	5.7	17	27.7
40	80.5	45	4±0.05	M6	9	G1/4	99.5	41.5	97.5	17.2	25	36.5
50	97	–	9H7	M8	–	G1/4	124.5	38.5	122.5	52.8	29.3	36
63	123.5	–	9H7	M10	–	G3/8	153.5	48.5	151	68	34.8	46

∅	H7	H8	H9	H10	H11	H12	J1	J2	J3	L1
[mm]						±0.05				
18	4.6	2.4	25.2	46	8.5±0.15	30	20	16.5	11	150
25	7.65	4.5	29	55.5	12±0.15	35	26.1	18.6	17	200
32	8.5	14	35.2	63.8	11.45±0.15	50	30	22	18.5	250
40	12.2	8	44	81.5	15±0.15	60	35	26	26	300
50	12	8	53	104.5	100±0.05	–	30.5	30.5	28	350
63	19.5	15.5	67	131	120±0.05	–	41.5	39.5	31.5	400

∅	L2	L3	L4	L5	L6	L8			T1	T2	T3	T6	Stroke tolerance
						PPV	YSR	YSRW					
[mm]											+0.2		
18	74.5	5.7	5.8	15	5.5	0	29.9	32.4	9	2	3.1	15	0 ... 2.5
25	100	10.5	10.6	24.5	10.6	0	35.6	38.6	17.5	2	2.1	17.3	
32	124.8	14.5	14.5	30.5	14.5	0	19.5	28	15	2	2.1	20	
40	150	14.6	14.6	33.5	14.6	0	38.5	43.5	20	3	2.1	25.7	
50	175	17	–	41	17	0	31	36.3	24	2.1 ^{+0.2}	–	28.75	
63	200	20	–	44	20	0	38.3	48.3	27.5	2.1 ^{+0.2}	–	36.1	

Linear drives DGC-KF, with recirculating ball bearing guide

1

Dimensions

Slide

Ø 18

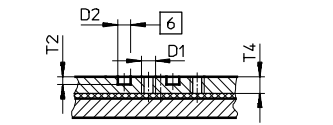

View A

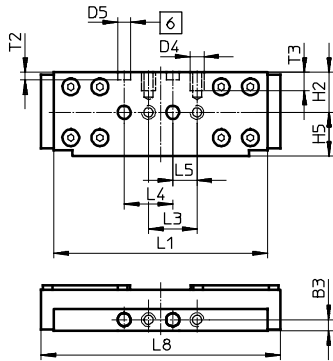

Ø 32

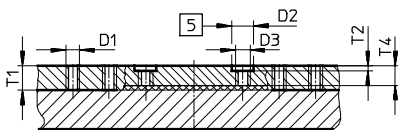

View A

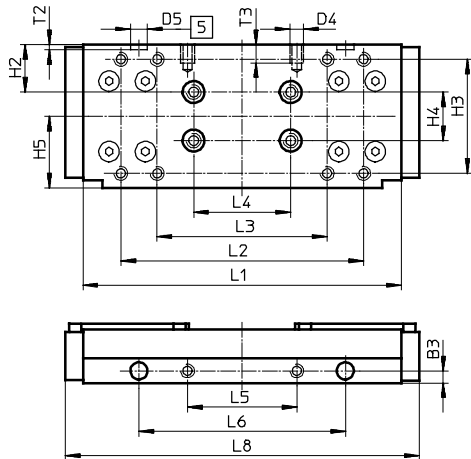

- 5 Hole for centring sleeve ZBH
- 6 Hole for centring pin ZBS

Ø 25

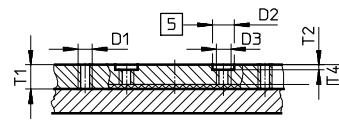

View A

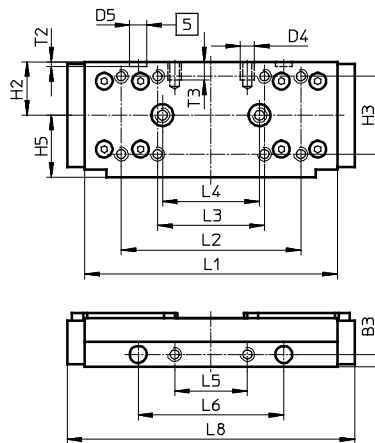

Ø 40

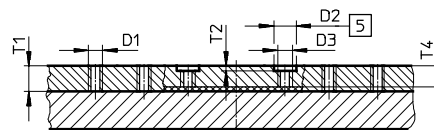

View A

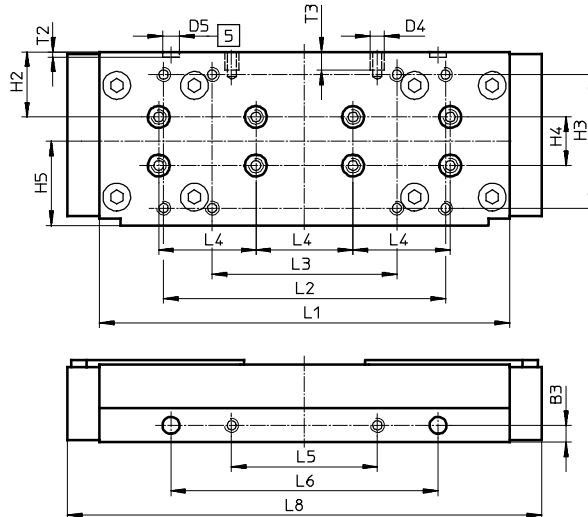

Linear drives DGC-KF, with recirculating ball bearing guide

Dimensions

Slide

Ø 50

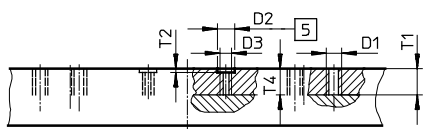

Ø 63

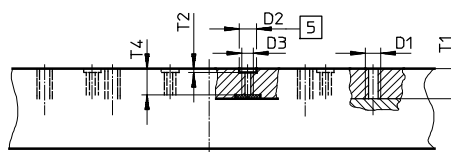

View A

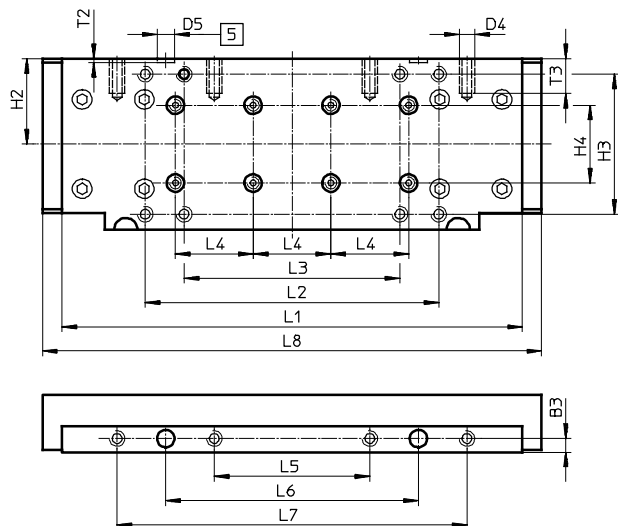

View A

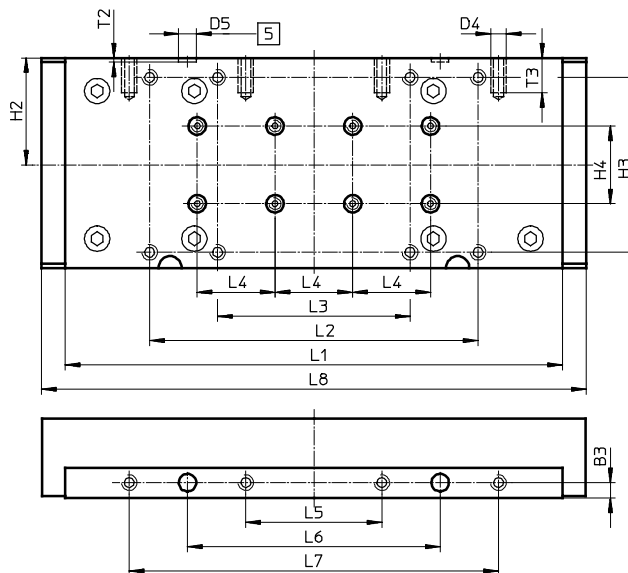

5 Hole for centring sleeve ZBH

Ø	B3	D1	D2	D3	D4	D5	H2	H3	H4	H5	L1
[mm]	±0.05		Ø H7			Ø H7			±0.03	±0.1	
18	4.5	M5	5	-	M5	5	16.5	-	-	18	88±0.1
25	5	M5	9	M6	M5	7	22	32±0.2	-	25.5	104±0.2
32	5	M5	9	M6	M5	7	19.5	47±0.2	20	29.5	131±0.2
40	7	M5	9	M6	M6	7	26.8	55±0.2	20	34.7	169±0.2
50	7	M8	9	M6	M8	9	44	72±0.3	40	-	237±0.1
63	8	M8	9	M6	M8	9	55	90±0.3	40	-	256±0.1

Ø	L2	L3	L4	L5	L6	L7	L8	T1	T2	T3	T4
[mm]	±0.1		±0.03	±0.1	±0.05	±0.1					
18	-	20±0.1	20	10	-	-	99	-	3.1±0.1	7.5	6.7
25	74	44±0.2	40	30	60	-	118.5	10	2.1±0.2	7.5	8
32	100	70±0.2	40	45	85	-	145.7	10	2.1±0.2	7.5	8
40	116	76±0.2	40	60	110	-	195.4	10.5	2.1±0.2	7.5	8.5
50	151	111±0.2	40	80	130	180	256.8	13.5	2.1±0.2	18	13.5
63	169	99±0.2	40	70	130	190	280	15.5	2.1±0.2	18	13.6

Linear drives DGC-KF, with recirculating ball bearing guide

Download CAD data → www.festo.com

1 Dimensions

Profile barrel

Ø 18

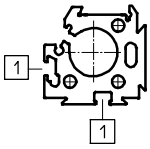

Ø 25

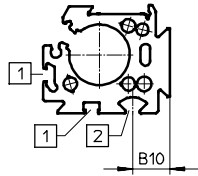

Ø 32

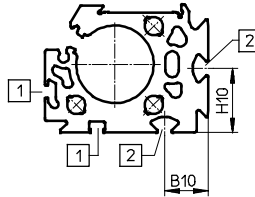

Ø 40

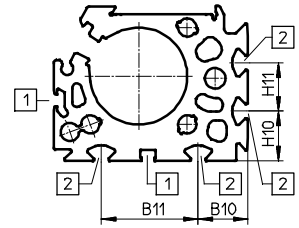

Ø 50

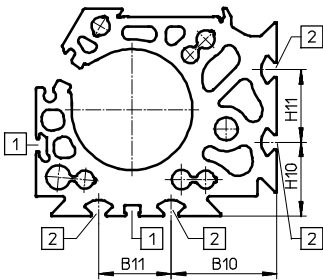

Ø 63

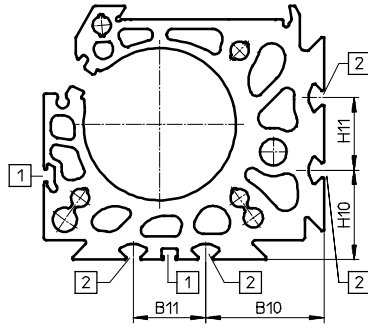

- 1 Slot for proximity sensor
- 2 Mounting slot for slot nut

Ø	B10	B11	H10	H11
25	15.23	-	-	-
32	18	-	26.5	-
40	20.5	40	20.5	20
50	43.8	30	30.5	30
63	49	30	37	30

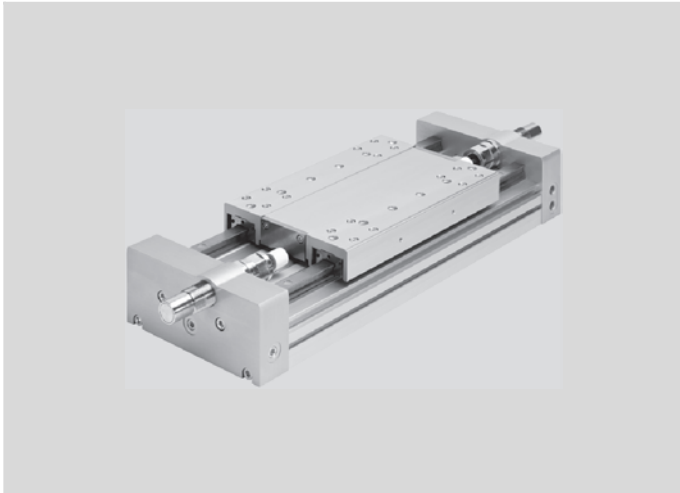

- Maximum loads and torques
- Long service life
- Ideal as a basic axis for linear gantries and cantilever axes
- Spare parts service

→ www.festo.com/catalogue/dgc-hd

Product range overview

Type/function	Piston Ø [mm]	Stroke [mm]	Force [N]	Product options		→ Page/online
				YSR	YSRW	
Double-acting	DGC-...-K – Compact design					
	18, 25, 32, 40, 50, 63, 80	1 ... 8,500	153 ... 3,016	-	-	dgc-k
	DGC-...-G – Basic design					
	8, 12, 18, 25, 32, 40, 50, 63	1 ... 8,500	30 ... 1,870	■	■	144
	DGC-...-GF – Plain-bearing guide					
	18, 25, 32, 40, 50, 63	1 ... 8,500	153 ... 1,870	■	■	147
DGC-...-KF – Recirculating ball bearing guide						
	8, 12, 18, 25, 32, 40, 50, 63	1 ... 8,500	30 ... 1,870	■	■	150
DGC-...-HD – Heavy-duty design						
	18, 25, 40	10 ... 5,000	153 ... 754	■	■	172
Without drive	DGC-FA – Passive guide axis					
	8, 12, 18, 25, 32, 40, 50, 63	1 ... 5,000	-	■	■	dgc-fa

Product options

YSR Linear shock absorber, self-adjusting

YSRW Progressive shock absorber, self-adjusting

GP Standard slide, protected
 KL Standard slide, left

KR Standard slide, right

Linear drives DGC-HD, with heavy-duty guide

FESTO

1 Technical data

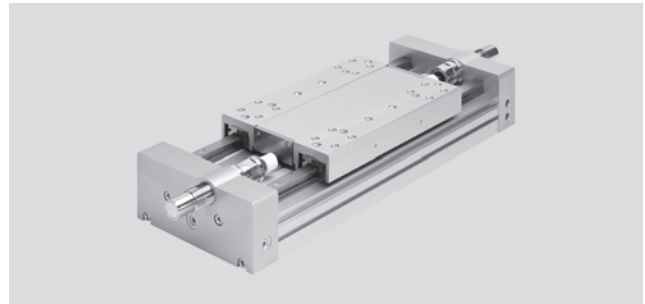

Technical data

Dimensions → 177

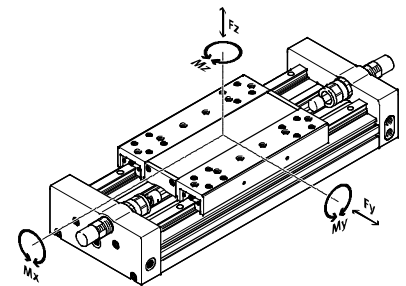

Technical data				
Piston Ø		18	25	40
Pneumatic connection		M5	G $\frac{1}{8}$	G $\frac{1}{4}$
Stroke	[mm]	10 ... 3,000	10 ... 5,000	10 ... 3,500
Cushioning				
DGC-...-YSR		Linear shock absorber, self-adjusting		
DGC-...-YSRW		Progressive shock absorber, self-adjusting		
Theoretical force at 6 bar	[N]	153	295	754
Max. permissible force F_y	[N]	3,650	5,600	13,000
Max. permissible force F_z	[N]	3,650	5,600	13,000
Max. permissible torque M_x	[Nm]	140	300	900
Max. permissible torque M_y	[Nm]	275	500	1,450
Max. permissible torque M_z	[Nm]	275	500	1,450

Operating conditions				
Piston Ø		18	25	40
Operating pressure	[bar]	2.5 ... 8	1.5 ... 8	
Ambient temperature ¹⁾	[°C]	-10 ... +60		

1) Note operating range of proximity sensors.

Materials	
End cap	Anodised aluminium
Slide	Anodised aluminium
Cylinder barrel	Anodised aluminium
Seals	NBR, TPE-U (PU)
Sealing band/cover strip:	PU/steel

Order code

1

		DGC	-		-		-	HD	-	
Type										
DGC	Linear drive									
Piston Ø [mm]										
	Stroke [mm]									
18	10 ... 3,000									
25	10 ... 5,000									
40	10 ... 3,500									
Guide										
HD	Heavy-duty guide									
Cushioning										
YSR	Linear shock absorber, self-adjusting									
YSRW	Progressive shock absorber, self-adjusting									

Ordering – Product options

	<p>Configurable product</p>	<p>This product and all its options can be ordered using the configurator.</p>	<p>The configurator can be found under Products on the DVD or → www.festo.com/catalogue/...</p>	<p>Enter the type code in the search field.</p>
--	------------------------------------	---	---	---

Linear drives DGC-HD, with heavy-duty guide

FESTO

Accessories

1

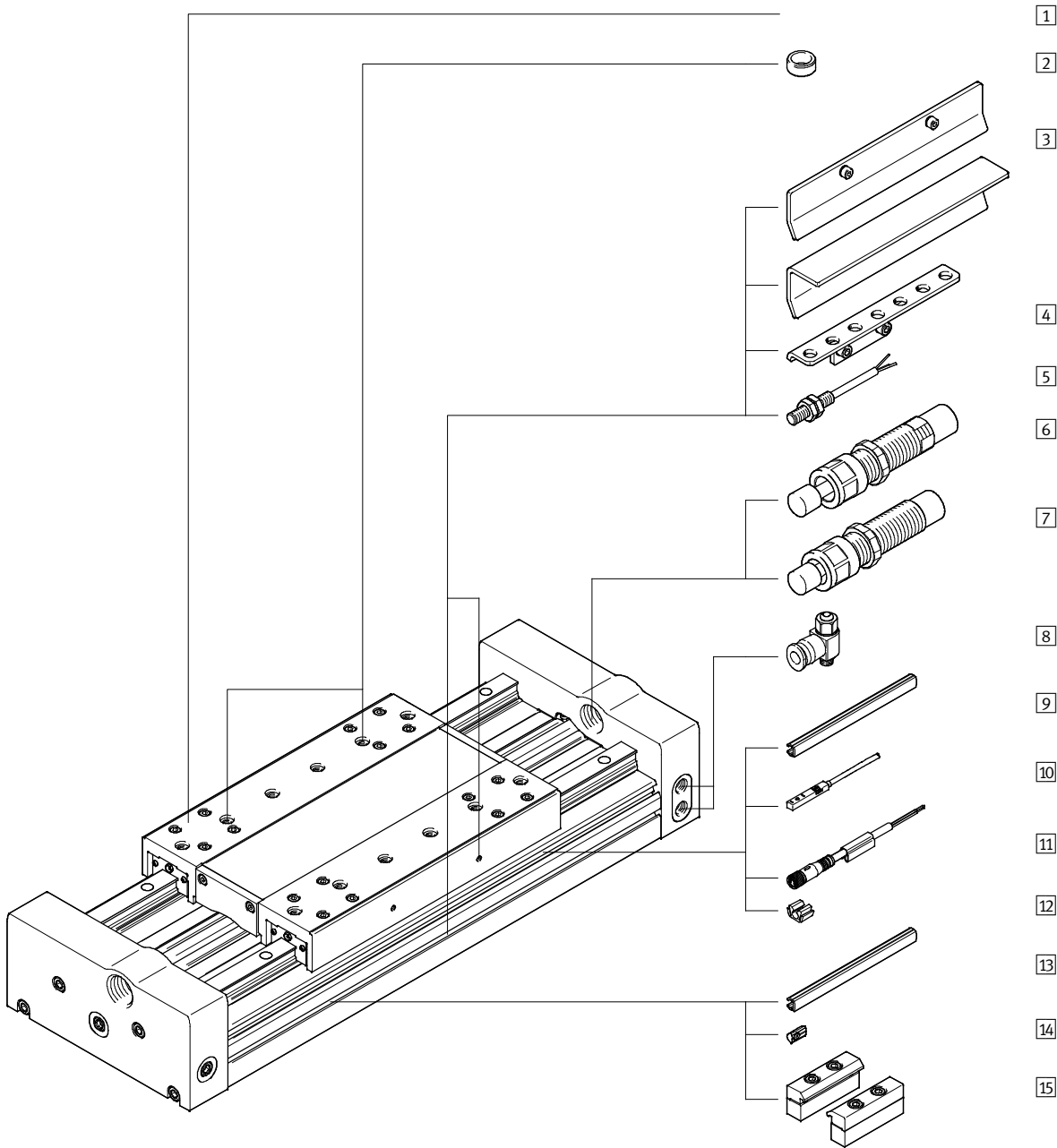



- 1
- 2
- 3
- 4
- 5
- 6
- 7
- 8
- 9
- 10
- 11
- 12
- 13
- 14
- 15

		→ Page/online
1	Linear drive DGC-HD	172
2	Centring sleeve ZBH	175
3	Switch lug SF-EGC-HD	175
4	Sensor bracket HWS-EGC	175
5	Proximity sensor, M8 SIEN	175
6	Shock absorber YSR	-
7	Shock absorber YSRW	175
8	One-way flow control valve GRLA	175

		→ Page/online
9	Slot cover ABP-S	175
10	Proximity sensor, T-slot SIES	176
10	Proximity sensor, T-slot SMT/SME-8	176
11	Connecting cable NEBU	176
12	Clip SMBK	176
13	Slot cover ABP	176
14	Slot nut NST	176
15	Profile mounting MUE	176

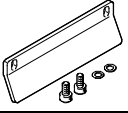
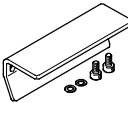
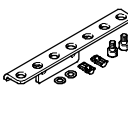
Accessories – Ordering data

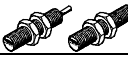
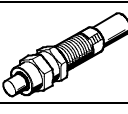
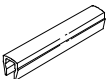
	For Ø	Part No.	Type	
[2] Centring pin/sleeve¹⁾²⁾				Technical data online: → zbh
	18	150928	ZBS-5	
	25, 40	150927	ZBH-9	
[3] Switch lug³⁾				Dimensions online: → dgc-hd
	18	570027	SF-EGC-HD-1-125	
	25	1645872	SF-EGC-HD-1-160	
	40	1645866	SF-EGC-HD-1-220	
[3] Switch lug⁴⁾				Dimensions online: → dgc-hd
	18	570030	SF-EGC-HD-2-125	
	25	1645865	SF-EGC-HD-2-160	
	40	1645868	SF-EGC-HD-2-220	
[4] Sensor bracket⁵⁾				Dimensions online: → dgc-hd
	18	558057	HWS-EGC-M5	
	25	558057	HWS-EGC-M5	
	40	570365	HWS-EGC-M8-B	
[5] Inductive proximity sensor, N/O contact, M8				Technical data → 755
	PNP, cable	★	150386	SIEN-M8B-PS-K-L
	PNP, plug	★	150387	SIEN-M8B-PS-S-L
N/C contact, M8				Technical data → 755
	PNP, cable		150390	SIEN-M8B-PO-K-L
	PNP, plug		150391	SIEN-M8B-PO-S-L
[7] Shock absorber				
	18	540351	YSRW-DGC-32-KF	
	25	1232870	YSRW-DGC-40/50-B	
	40	543069	YSRW-DGC-63	
[9] Slot cover⁶⁾				
	18, 25, 40	563360	ABP-5-S1	

- 1) Packaging unit 10 pieces.
- 2) 2 centring pins/sleeves included in the scope of delivery of the axis.
- 3) For sensing via proximity sensor SIES-8M.
- 4) For sensing via proximity sensor SIEN-M8B or SIES-8M.
- 5) For proximity sensor SIEN-M8B.
- 6) Packaging unit 2x 0.5 m.

Function	For Ø	Connection		Part No.	Type	
		Thread	O.D.			
[8] One-way flow control valve with slotted head screw, metal⁷⁾						
	8, 12	M5	3	★	193137	GRLA-M5-QS-3-D
	18		6	★	193139	GRLA-M5-QS-6-D
	25, 32	G1/8	8		162966	GRLA-1/8-QS-8-RS-B
	40, 50	G1/4			162968	GRLA-1/4-QS-8-RS-B
	63	G3/8			162970	GRLA-3/8-QS-8-RS-B



7) The recommended flow control valves are based on a tubing length to the valve of 1 m. For deviations of ±50%, flow control valves with a bigger or smaller flow rate must be selected to guarantee the optimum flow control function and cylinder speed.

Linear drives DGC-HD, with heavy-duty guide

FESTO

Accessories – Ordering data

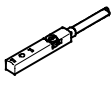
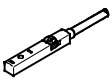
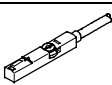
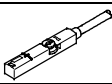
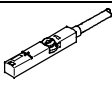
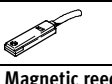
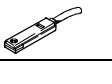
1

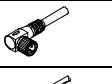
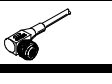
	For Ø	Part No.	Type	
10 Proximity sensor for T-slot, inductive, N/O contact				Technical data → 759
	PNP, cable	551386	SIES-8M-PS-24V-K-7,5-OE	
	PNP, plug	551387	SIES-8M-PS-24V-K-0,3-M8D	
	NPN, cable	551396	SIES-8M-NS-24V-K-7,5-OE	
	NPN, plug	551397	SIES-8M-NS-24V-K-0,3-M8D	
N/C contact				Technical data → 759
	PNP, cable	551391	SIES-8M-PO-24V-K-7,5-OE	
	PNP, plug	551392	SIES-8M-PO-24V-K-0,3-M8D	
	NPN, cable	551401	SIES-8M-NO-24V-K-7,5-OE	
	NPN, plug	551402	SIES-8M-NO-24V-K-0,3-M8D	
Proximity sensor for T-slot, magneto-resistive – N/O contact				Technical data → 737
	PNP, cable	★ 574335	SMT-8M-A-PS-24V-E-2,5-OE	
	PNP, plug	★ 574334	SMT-8M-A-PS-24V-E-0,3-M8D	
	PNP, plug	★ 574337	SMT-8M-A-PS-24V-E-0,3-M12	
	NPN, cable	★ 574338	SMT-8M-A-NS-24V-E-2,5-OE	
	NPN, plug	★ 574339	SMT-8M-A-NS-24V-E-0,3-M8D	
Magneto-resistive – N/C contact				Technical data → 737
	PNP, cable	★ 574340	SMT-8M-A-PO-24V-E-7,5-OE	
Magnetic reed – N/O contact				Technical data → 732
	Cable	★ 543862	SME-8M-DS-24V-K-2,5-OE	
	Cable	★ 543863	SME-8M-DS-24V-K-5,0-OE	
	Cable	★ 543872	SME-8M-ZS-24V-K-2,5-OE	
	Plug	★ 543861	SME-8M-DS-24V-K-0,3-M8D	
				Technical data → 734
	Cable	★ 150855	SME-8-K-LED-24	
	Plug	150857	SME-8-S-LED-24	
Magnetic reed – N/C contact				Technical data → 734
	Cable	160251	SME-8-O-K-LED-24	
11 Connecting cable, straight socket				Technical data → 949
	2.5 m	★ 541333	NEBU-M8G3-K-2.5-LE3	
	5.0 m	★ 541334	NEBU-M8G3-K-5-LE3	
	2.5 m	541363	NEBU-M12G5-K-2.5-LE3	
	5.0 m	541364	NEBU-M12G5-K-5-LE3	
Angled socket				Technical data → 949
	2.5 m	★ 541338	NEBU-M8W3-K-2.5-LE3	
	5.0 m	★ 541341	NEBU-M8W3-K-5-LE3	
	2.5 m	541367	NEBU-M12W5-K-2.5-LE3	
	5.0 m	541370	NEBU-M12W5-K-5-LE3	

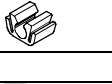
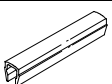
	For Ø	Part No.	Type
12 Clip			
	18, 25, 40	534254	SMBK-8
13 Slot cover¹⁾			
	18	151681	ABP-5
	25	151680	ABP-5-S
	40	151682	ABP-8

1) Packaging unit 2x 0.5 m.

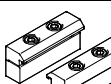
	For Ø	Part No.	Type
14 Slot nut			
	18, 25 ²⁾	150914	NST-5-M5
	25 ³⁾ , 40	150915	NST-5-M6
15 Profile mounting Dimensions online: → dgc-hd			
	18, 25	★ 558043	MUE-70/80
	40	558044	MUE-120/185

2) For mounting slot at side.
3) For mounting slot underneath.

Dimensions

Download CAD data → www.festo.com

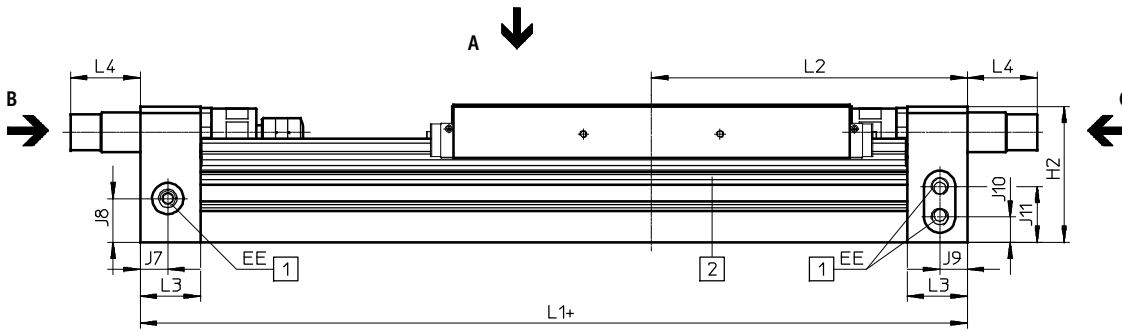

View C

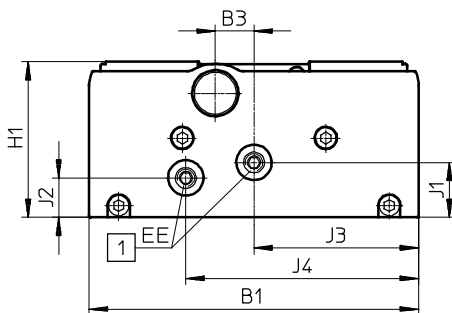

View B

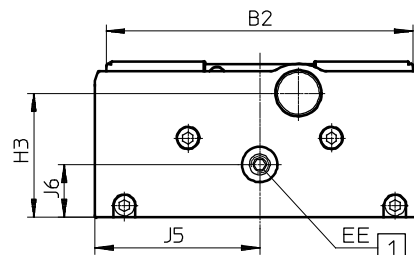

- + plus stroke length
- 1 Supply port
- 2 Sensor slot for proximity sensor

∅	B1	B2	B3	EE	H1	H2	H3	J1	J2	J3	J4
[mm]											
18	124	120	7	M5	64	63.1	51.7	25.5	15	59	88
25	162	150.7	19	G1/8	76.5	75.5	61	27	19.4	81	114.5
40	222	204	12	G1/4	111.5	109.5	91	43	25	105	157

∅	J5	J6	J7	J8	J9	J10	J11	L1	L2	L3	L4	
[mm]											YSR	YSRW
18	59	25.5	14.9	21.6	14.9	15	25.6	306.5	153	24.5	34	20.5
25	81	26	15.4	24.3	15.4	14	31	351.5	175.5	33.5	43.8	38.8
40	111	37	25.1	31	25.1	23	45	472.5	236	44	48.3	38.3

Profile barrel

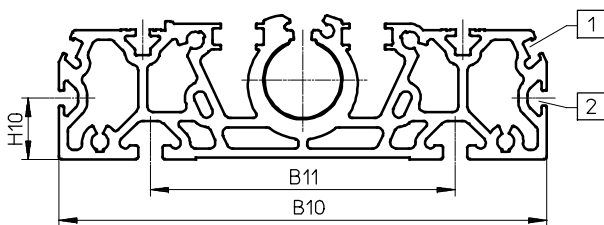

- 1 Sensor slot for proximity sensor
- 2 Mounting slot for slot nut

∅	B10	B11	H10
[mm]			
18	122	80	20
25	160	100	20
40	220	140	20

Linear drives DGC-HD, with heavy-duty guide

FESTO

Download CAD data → www.festo.com

Dimensions

1

∅ 18

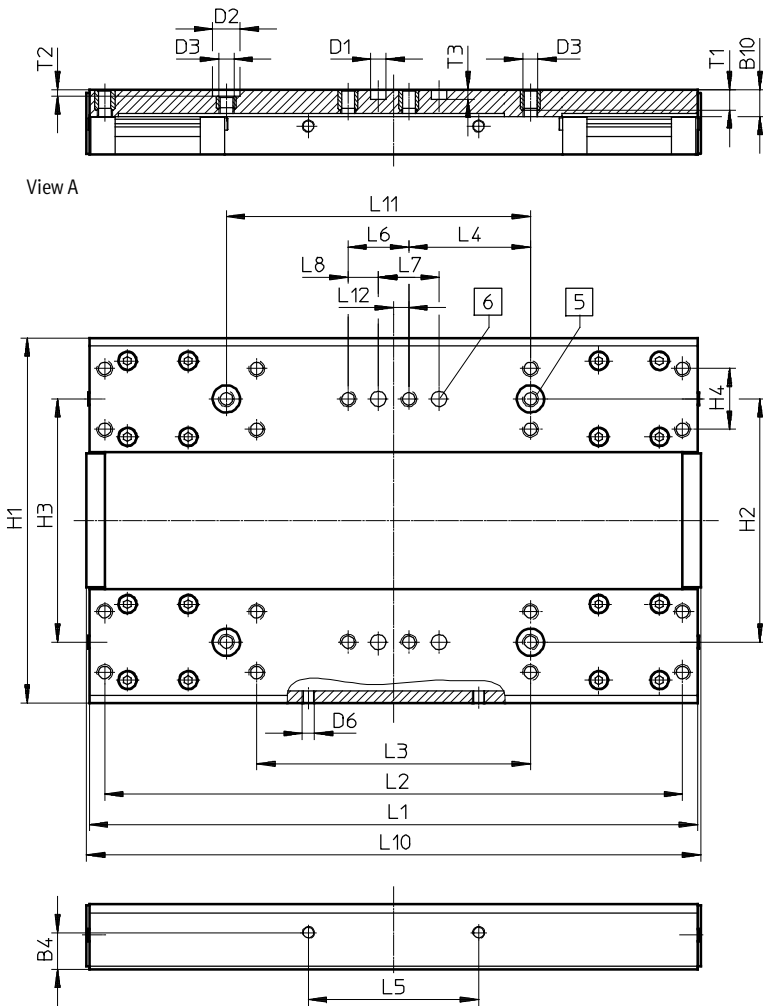

- 5 Hole for centring sleeve ZBH
- 6 Hole for centring pin ZBS

∅	B4	B10	D1	D2	D3	D6	H1	H2	H3	H4	L1	L2
[mm]	±0.1		∅ H7	∅ H7			±0.3	±0.05		±0.1	±0.1	±0.2
18	12	8.8	5	9	M5	M4	120	80	80	20	200	190

∅	L3	L4	L5	L6	L7	L8	L10	L11	L12	T1	T2	T3
[mm]	±0.2	±0.1	±0.2	±0.1	±0.03	±0.1		±0.03			+0.1	+0.1
18	90	40	56	20	20	10	202	100	5	7.8	2.1	3.1

Dimensions

∅ 25

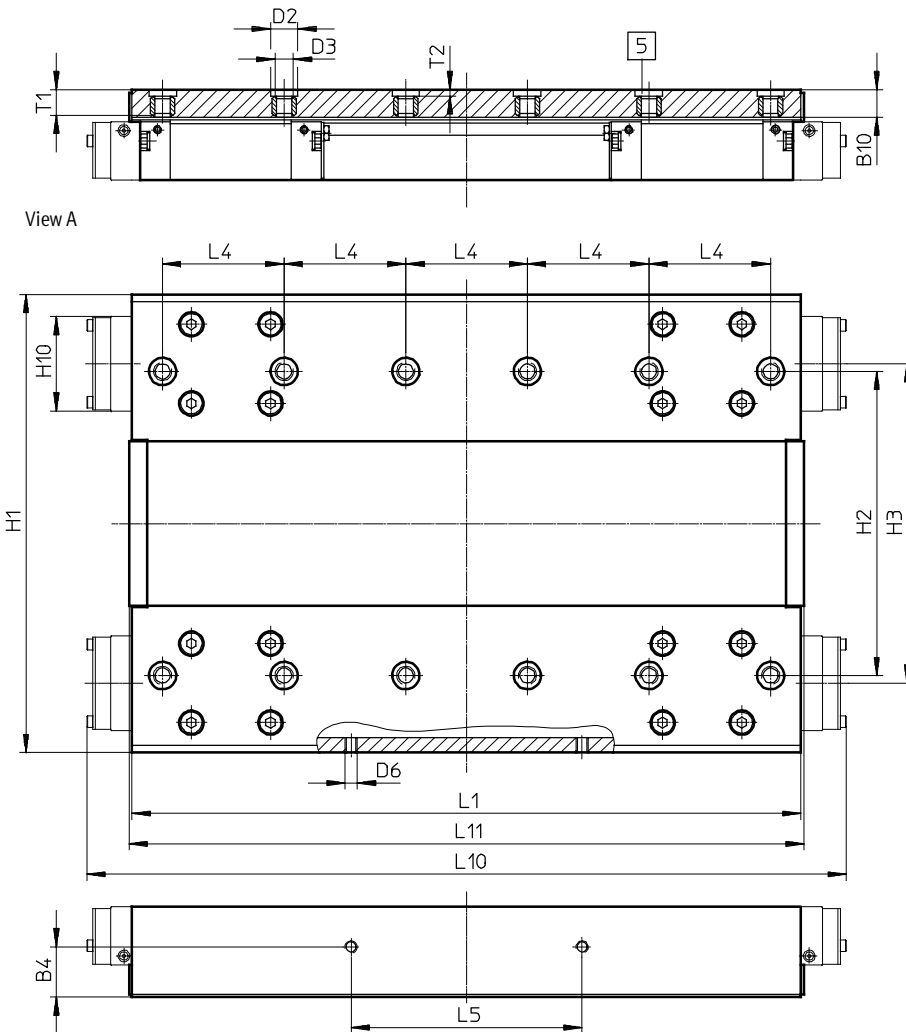

5 Hole for centring sleeve ZBH

∅	B4	B10*	D2	D3	D6	H1	H2	H3
[mm]	±0.1		∅ H7			±0.3	±0.05	
25	16.5	10	9	M6	M4	150.7	100	105

∅	H10*	L1	L4	L5	L10*	L11	T1	T2
[mm]		±0.1	±0.03	±0.1				+0.1
25	31	220	40	76	249.8	222	9	2.1

* Protected version

Linear drives DGC-HD, with heavy-duty guide

FESTO

Download CAD data → www.festo.com

Dimensions

1

∅ 40

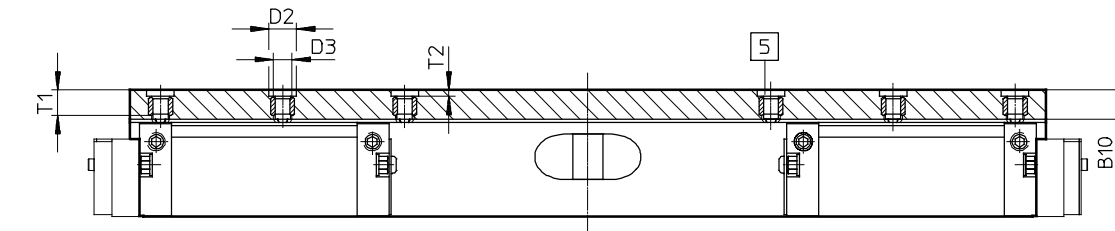

View A

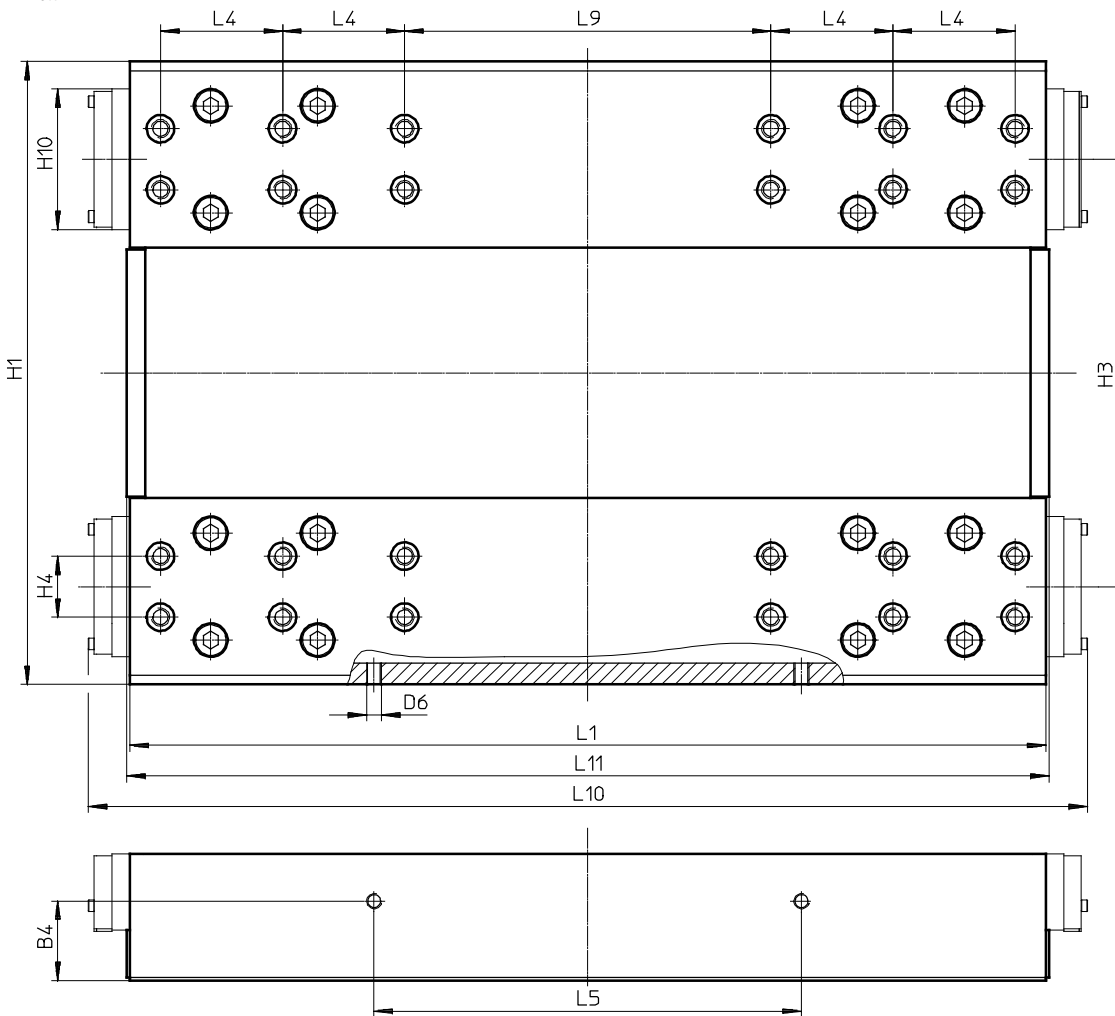

5 Hole for centring sleeve ZBH

∅	B4	B10*	D2	D3	D6	H1	H3	H4
[mm]	±0.1		∅ H7			±0.3		±0.05
40	26	10.5	9	M6	M5	204	140	20

∅	H10*	L1	L4	L5	L9	L10*	L11	T1	T2
[mm]		±0.1	±0.05	±0.1	±0.05				+0.1
40	46	300	40	140	120	327.3	302	9.5	2.1

* Protected version



- Very high accuracy in the end positions
 - Very high load bearing capacity
 - Very good axial run-out at the flanged shaft
 - High mass moments of inertia
 - Low-backlash and dynamic
- ★ Quick ordering of basic designs → 187

→ www.festo.com/catalogue/drrd

Product range overview

Type/function	Version	Size	Swivel angle [°]	Torque [Nm]	Product options																	
					FH	P	Y9	Y10	Y12	A	E1	R	SG	DN								
DRRD																						
Double-acting	Basic design	16, 20, 25, 32, 35, 40	180	1.6 ... 24.1	■	■	■	■	■	■	■	■	■	■	■							

Product options

FH	Hollow flanged shaft	Y10	Linear shock absorber, self-adjusting at both ends, hard	A	Position sensing	R	Sensor mounting, external
P	Elastic cushioning rings/pads at both ends	Y12	Linear shock absorber, self-adjusting at both ends, external	EX4	EU certification (II 2 GD)	SG	Splash-proof
Y9	Linear shock absorber, self-adjusting at both ends			E1	End-position locking at both ends	DN	Without operating instructions

Technical data



Technical data		Dimensions → 190						
Size		16	20	25	32	35	40	
Pneumatic connection		M5			G1/8			
Type of mounting		Via female thread						
Swivel angle	[°]	180						
Cushioning with fixed stop								
DRRD-...-P		Elastic cushioning rings/pads at both ends						
DRRD-...-Y9		Linear shock absorber, self-adjusting at both ends						
DRRD-...-Y10		–		Linear shock absorber, self-adjusting at both ends, hard	–	Linear shock absorber, self-adjusting at both ends, hard		
DRRD-...-Y12		Linear shock absorber, self-adjusting at both ends, external						
Theoretical torque at 6 bar	[Nm]	1.6	2.4	5.1	10.1	15.8	24.1	
Max. permissible mass moment of inertia								
DRRD-...-P	[kgcm ²]	180	400	900	1,500	2,500	6,700	
DRRD-...-Y9	[kgcm ²]	700	1,300	1,500	8,000	15,000	23,000	
DRRD-...-Y10	[kgcm ²]	–	–	5,500	–	45,000	67,000	
DRRD-...-Y12	[kgcm ²]	900	1,500	5,500	26,000	45,000	67,000	
Max. axial load (static)	[N]	1,500	2,400	2,400	3,750	6,100	6,100	

Semi-rotary drives DRRD, twin pistons

FESTO

Technical data

1 Axial run-out in new condition < 0.05 mm

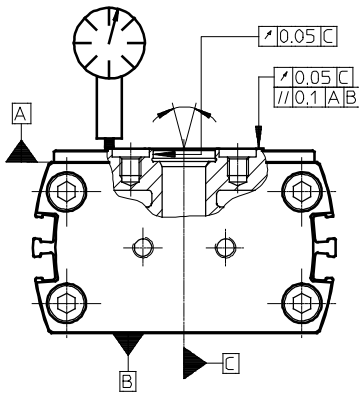

Operating conditions

Operating medium	Compressed air to ISO 8573-1:2010 [7:4:4]	
Operating pressure		
DRRD-...-P	[bar]	3 ... 8
DRRD-...-Y9/-Y10/-Y12	[bar]	2 ... 10
Ambient temperature	[°C]	-10 ... +60
Storage temperature	[°C]	-20 ... +60
Protection class based on EN 60529		
DRRD-...-SG	IP65	

Materials

Drive shaft	Tempered steel
End cap	Anodised wrought aluminium alloy
Housing	Smooth anodised wrought aluminium alloy
Piston	Stainless steel
Seals	TPE-U (PU), NBR

Technical data

Max. permissible mass moment of inertia J at the flanged shaft as a function of swivel time s

(at room temperature and operating pressure of 6 bar)

With cushioning P

Size 16

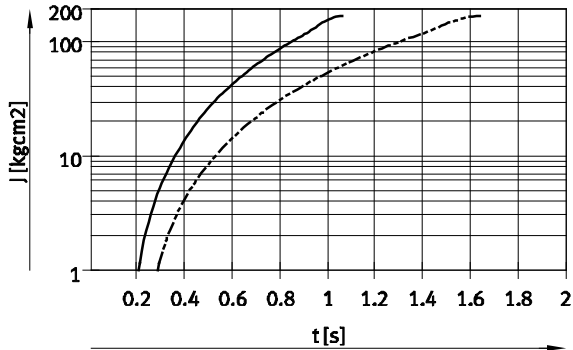

— DRRD-16-...-P (90°) Ranges → 1 ... 175 kgcm²
 - - - DRRD-16-...-P (180°) Ranges → 1 ... 175 kgcm²

Size 20

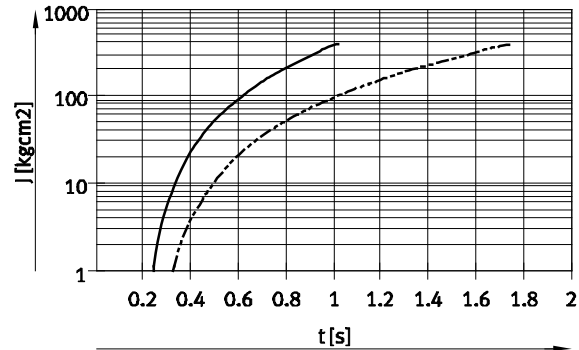

— DRRD-20-...-P (90°) Ranges → 1 ... 400 kgcm²
 - - - DRRD-20-...-P (180°) Ranges → 1 ... 400 kgcm²

Size 25

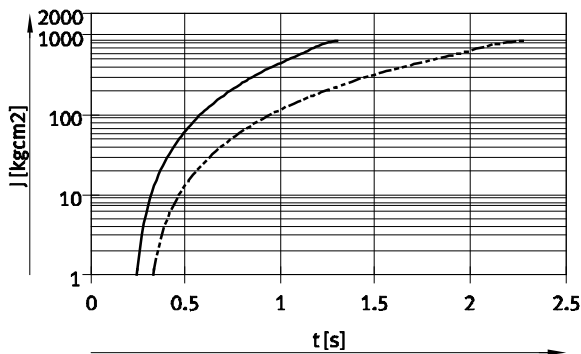

— DRRD-25-...-P (90°) Ranges → 1 ... 900 kgcm²
 - - - DRRD-25-...-P (180°) Ranges → 1 ... 900 kgcm²

Size 32

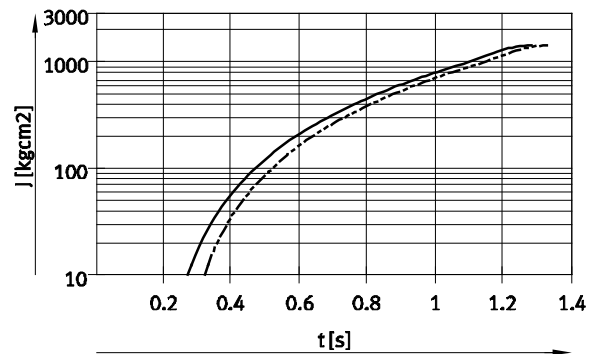

— DRRD-32-...-P (90°) Ranges → 10 ... 1,500 kgcm²
 - - - DRRD-32-...-P (180°) Ranges → 10 ... 1,500 kgcm²

Size 35

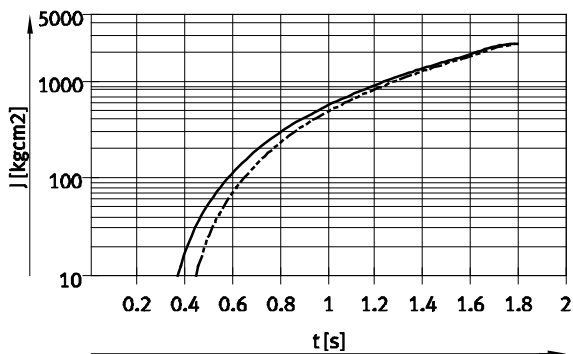

— DRRD-35-...-P (90°) Ranges → 10 ... 2,500 kgcm²
 - - - DRRD-35-...-P (180°) Ranges → 10 ... 2,500 kgcm²

Size 40

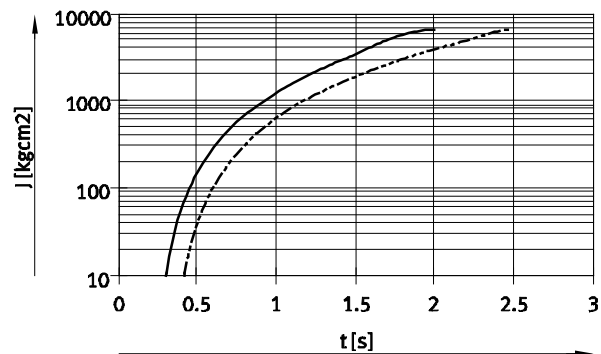

— DRRD-40-...-P (90°) Ranges → 10 ... 6,700 kgcm²
 - - - DRRD-40-...-P (180°) Ranges → 10 ... 6,700 kgcm²

Semi-rotary drives DRRD, twin pistons

FESTO

Technical data

1

Max. permissible mass moment of inertia J at the flanged shaft as a function of swivel time s

(at room temperature and operating pressure of 6 bar)

With cushioning Y9/Y10

Size 16

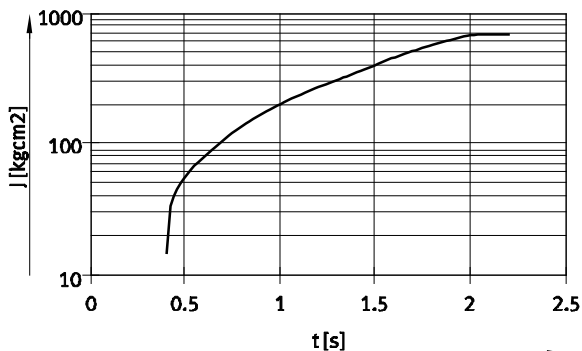

— DRRD-16-180-...-Y9 (180°) → 15 ... 700 kgcm²

Size 20

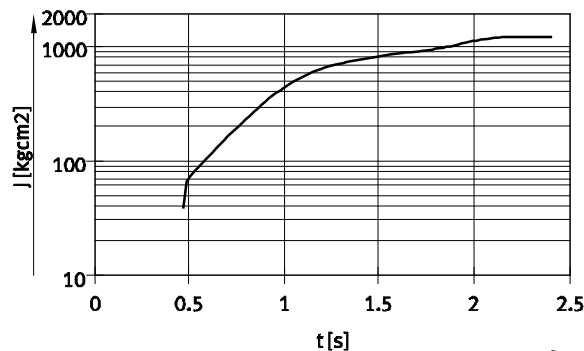

— DRRD-20-180-...-Y9 (180°) → 40 ... 1,250 kgcm²

Size 25

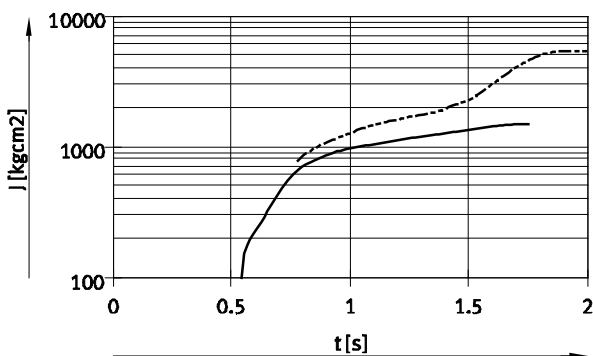

— DRRD-25-180-...-Y9 (180°) → 100 ... 1,500 kgcm²
 - - - DRRD-25-180-...-Y10 (180°) → 800 ... 5,500 kgcm²

Size 32

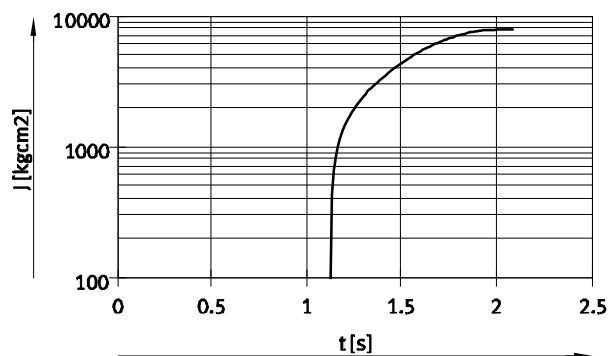

— DRRD-32-180-...-Y9 (180°) → 100 ... 8,000 kgcm²

Size 35

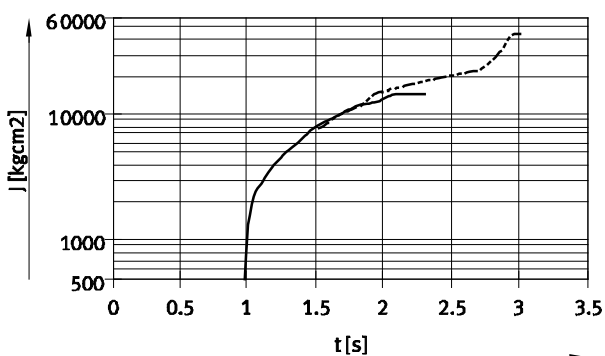

— DRRD-35-180-...-Y9 (180°) → 500 ... 15,000 kgcm²
 - - - DRRD-35-180-...-Y10 (180°) → 8,000 ... 45,000 kgcm²

Size 40

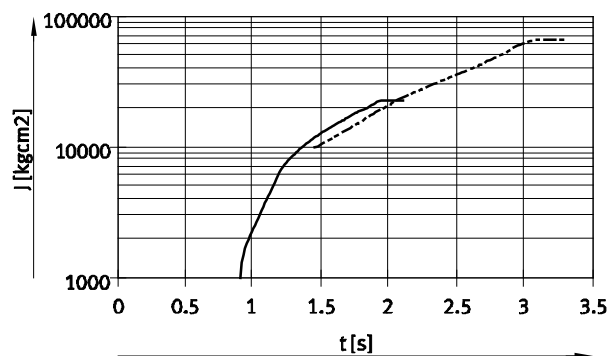

— DRRD-40-180-...-Y9 (180°) → 1,000 ... 23,000 kgcm²
 - - - DRRD-40-180-...-Y10 (180°) → 10,000 ... 67,000 kgcm²

Technical data

Max. permissible mass moment of inertia J at the flanged shaft as a function of swivel time t

(at room temperature and operating pressure of 6 bar)

With cushioning Y12

Size 16

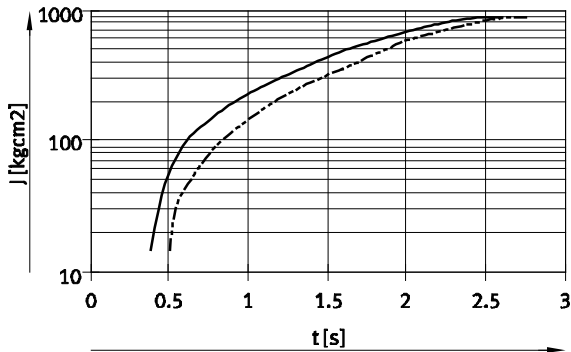

—	DRRD-16-...-Y12 (90°)	Ranges	→ 15 ... 900 kgcm ²
- - -	DRRD-16-...-Y12 (180°)		→ 15 ... 900 kgcm ²

Size 20

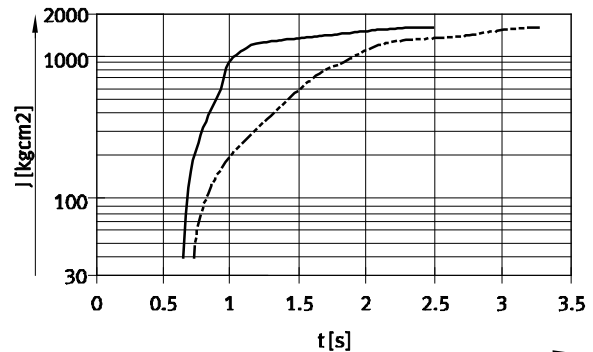

—	DRRD-20-...-Y12 (90°)	Ranges	→ 40 ... 1,500 kgcm ²
- - -	DRRD-20-...-Y12 (180°)		→ 40 ... 1,500 kgcm ²

Size 25

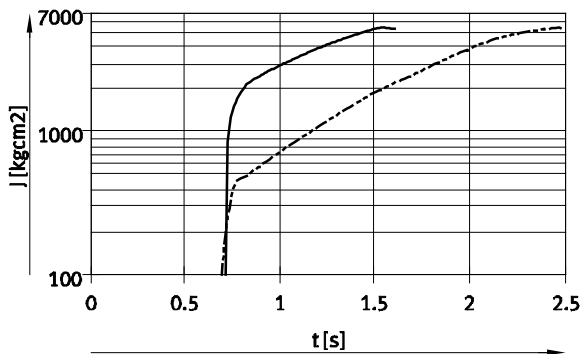

—	DRRD-25-...-Y12 (90°)	Ranges	→ 100 ... 5,500 kgcm ²
- - -	DRRD-25-...-Y12 (180°)		→ 100 ... 5,500 kgcm ²

Size 32

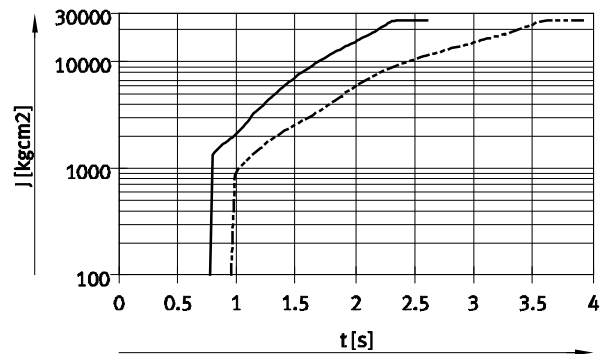

—	DRRD-32-...-Y12 (90°)	Ranges	→ 100 ... 26,000 kgcm ²
- - -	DRRD-32-...-Y12 (180°)		→ 100 ... 26,000 kgcm ²

Size 35

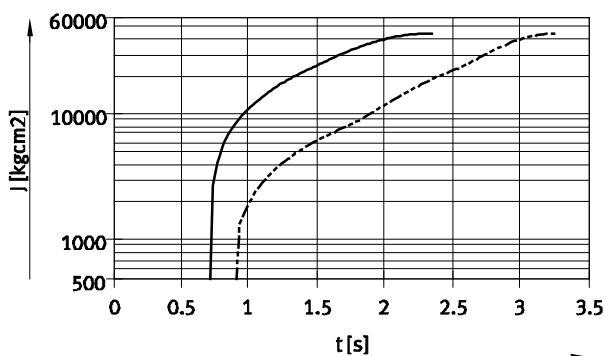

—	DRRD-35-...-Y12 (90°)	Ranges	→ 500 ... 45,000 kgcm ²
- - -	DRRD-35-...-Y12 (180°)		→ 500 ... 45,000 kgcm ²

Size 40

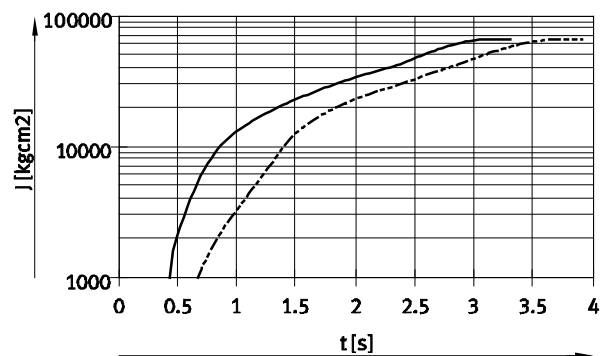

—	DRRD-40-...-Y12 (90°)	Ranges	→ 1,000 ... 67,000 kgcm ²
- - -	DRRD-40-...-Y12 (180°)		→ 1,000 ... 67,000 kgcm ²

★ Quick ordering

P – Elastic cushioning rings/pads at both ends			
Piston Ø	Swivel angle	Part No.	Type
16	180°	1577238	DRRD-16-180-FH-PA
20		1395606	DRRD-20-180-FH-PA
25		1359980	DRRD-25-180-FH-PA
32		1578512	DRRD-32-180-FH-PA
35		1526825	DRRD-35-180-FH-PA
40		1503269	DRRD-40-180-FH-PA

Y9 – Linear shock absorber, self-adjusting at both ends			
Piston Ø	Swivel angle	Part No.	Type
16	180°	1644389	DRRD-16-180-FH-Y9A
20		1427379	DRRD-20-180-FH-Y9A
25		1360248	DRRD-25-180-FH-Y9A
32		1578518	DRRD-32-180-FH-Y9A
35		1547102	DRRD-35-180-FH-Y9A
40		1526986	DRRD-40-180-FH-Y9A

Accessories

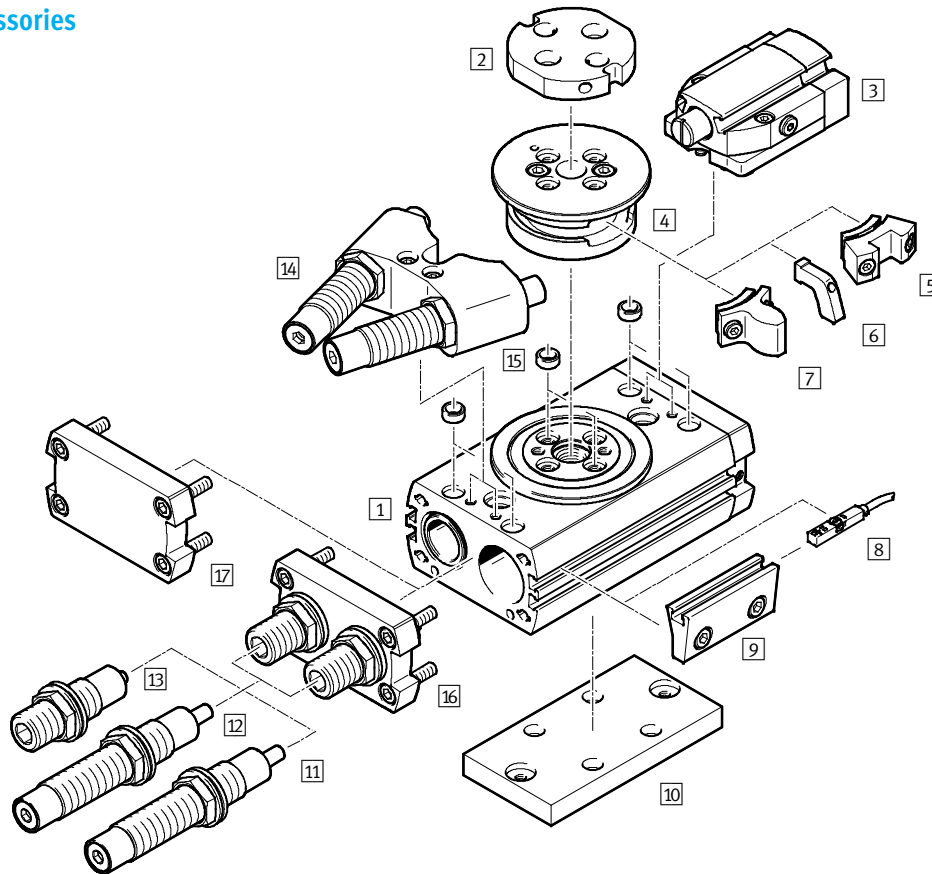



		→ Page/ online
1	Semi-rotary drive DRRD	181
2	Adapter kit DHAA	Included in the scope of delivery: 2 centring sleeves and screws kit
3	End-position lock E1 (clamping unit DADL-...-EL as an accessory)	Included in the scope of delivery: 3, 4, 2x 5 188
4	Flange assembly	Required to mount components 5, 6 and 7 188
5	Clamping component (type: DADL-EC)	Secures the semi-rotary drive when the cylinder is advanced 188
6	Switch lug DASI-Q11-...-SL	Two switch lugs are included in the scope of delivery of the sensor mounting kit (R) 188
7	Stop element	Two stop elements are included in the scope of delivery of external shock absorbers (Y12) –
8	Proximity sensor SMT-/SME-8	For sensing the piston position 189
9	Sensor mounting kit R (sensing kit DASI-...-KT as an accessory)	Included in the scope of delivery: 4, 2x 6, 2x 9 188
10	Adapter kit DHAA	Connecting plate between semi-rotary drive and drive adapter
11	Shock absorber Y9	Linear shock absorber, self-adjusting at both ends 186
12	Shock absorber, hard Y10	Linear shock absorber, self-adjusting at both ends, hard 186
13	Shock absorber P	Elastic cushioning with metal end position, both ends 186
14	Shock absorber, external Y12	Linear shock absorber, self-adjusting at both ends, external, included in the scope of delivery: 4, 2x 7, 14 186
15	Centring sleeve ZBH	2 centring sleeves included in the scope of delivery of the drive 188
16	End cap	In combination with elastic cushioning P or shock absorber Y9, Y10 –
17	End cap	In combination with external shock absorber Y12 –

Semi-rotary drives DRRD, twin pistons

FESTO

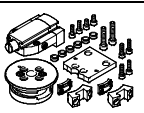

Accessories – Ordering data

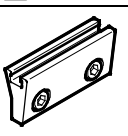
1



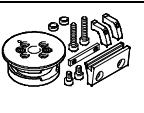
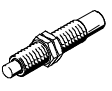

	For Ø	Part No.	Type
3 Clamping unit DADL-EL Technical data online: → drrd			
	16	1692770	DADL-EL-Q11-16
	20	1579786	DADL-EL-Q11-20
	25	1568183	DADL-EL-Q11-25
	32	1631139	DADL-EL-Q11-32
	35	1544900	DADL-EL-Q11-35/40
	40	1544900	DADL-EL-Q11-35/40
5 Clamping component DADL-EC Technical data online: → drrd			
	16	1692496	DADL-EC-Q11-16
	20, 25	1435411	DADL-EC-Q11-20/25
	32	1631170	DADL-EC-Q11-32
	35, 40	1535091	DADL-EC-Q11-35/40
6 Switch lug DASI-...-SL Technical data online: → drrd			
	16	1692969	DASI-Q11-16-A-SL
	20, 25	1568436	DASI-Q11-20/25-A-SL
	32	1631824	DASI-Q11-32-A-SL
	35, 40	1548155	DASI-Q11-35/40-A-SL
6 Sensor bracket DASI-...-SR¹⁾ Technical data online: → drrd			
	16	1692983	DASI-Q11-16-A-SR
	20	1581420	DASI-Q11-20-A-SR
	25	1568451	DASI-Q11-25-A-SR
	32	1631997	DASI-Q11-32-A-SR
	35	1550870	DASI-Q11-35-A-SR
	40	1548054	DASI-Q11-40-A-SR

1) Packaging unit 2 pieces.

2) Packaging 10 pieces.

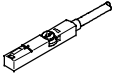
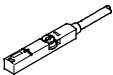
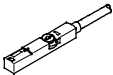
	For Ø	Part No.	Type
9 Sensing kit DASI-...-KT Technical data online: → drrd			
	16	1693008	DASI-Q11-16-A-KT
	20	1580899	DASI-Q11-20-A-KT
	25	1568461	DASI-Q11-25-A-KT
	32	1632097	DASI-Q11-32-A-KT
	35	1551144	DASI-Q11-35-A-KT
	40	1550027	DASI-Q11-40-A-KT
14 Shock absorber DYSC Technical data online: → drrd			
	16	548012	DYSC-7-5-Y1F
	20	548013	DYSC-8-8-Y1F
	25	548014	DYSC-12-12-Y1F
	32, 35, 40	553593	DYSC-16-18-Y1F
15 Centring sleeve²⁾ Technical data online: → drrd			
For housing			
	16, 20	150927	ZBH-9
	25	189653	ZBH-12
	32 ... 40	191409	ZBH-15
For flanged shaft			
	16, 20	186717	ZBH-7
	25 ... 40	150927	ZBH-9

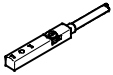
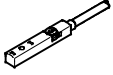
Accessories – Ordering data

	For Ø		Part No.	Type	
8] Proximity sensor for T-slot, magneto-resistive – N/O contact					Technical data → 737
	PNP, cable	★	574335	SMT-8M-A-PS-24V-K-2,5-OE	
	PNP, plug	★	574334	SMT-8M-A-PS-24V-K-0,3-M8D	
	PNP, plug	★	574337	SMT-8M-A-PS-24V-K-0,3-M12	
	NPN, cable	★	574338	SMT-8M-A-NS-24V-K-2,5-OE	
	NPN, plug	★	574339	SMT-8M-A-NS-24V-K-0,3-M8D	
Magneto-resistive – N/C contact					Technical data → 737
	PNP, cable	★	574340	SMT-8M-A-PO-24V-E-7,5-OE	
Magnetic reed – N/O contact					Technical data → 732
	Cable	★	543862	SME-8M-DS-24V-K-2,5-OE	
	Cable	★	543863	SME-8M-DS-24V-K-5,0-OE	
	Cable	★	543872	SME-8M-ZS-24V-K-2,5-OE	
	Plug	★	543861	SME-8M-DS-24V-K-0,3-M8D	
					Technical data → 734
	Cable	★	150855	SME-8-K-LED-24	
	Plug		150857	SME-8-S-LED-24	
8] Proximity sensor, for T-slot, inductive – N/O contact					Technical data → 759
	PNP, M8, cable		551386	SIES-8M-PS-24V-K-7,5-OE	
	PNP, M8, plug		551387	SIES-8M-PS-24V-K-0,3-M8D	
	NPN, M8, cable		551396	SIES-8M-NS-24V-K-7,5-OE	
	NPN, M8, plug		551397	SIES-8M-NS-24V-K-0,3-M8D	
Inductive – N/C contact					Technical data → 759
	PNP, M8, cable		551391	SIES-8M-PO-24V-K-7,5-OE	
	PNP, M8, plug		551392	SIES-8M-PO-24V-K-0,3-M8D	
	NPN, M8, cable		551401	SIES-8M-NO-24V-K-7,5-OE	
	NPN, M8, plug		551402	SIES-8M-NO-24V-K-0,3-M8D	
Connecting cable, straight socket					Technical data → 949
	2.5 m	★	541333	NEBU-M8G3-K-2.5-LE3	
	5 m	★	541334	NEBU-M8G3-K-5-LE3	
Angled socket					Technical data → 949
	2.5 m	★	541338	NEBU-M8W3-K-2.5-LE3	
	5 m	★	541341	NEBU-M8W3-K-5-LE3	

Note

The inductive proximity sensors SIES can only be used in combination with the sensing kit DASI-...-KT.

Semi-rotary drives DRRD, twin pistons

FESTO

Download CAD data → www.festo.com

Dimensions

1

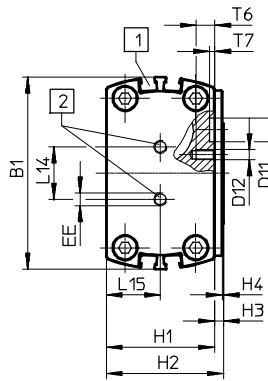
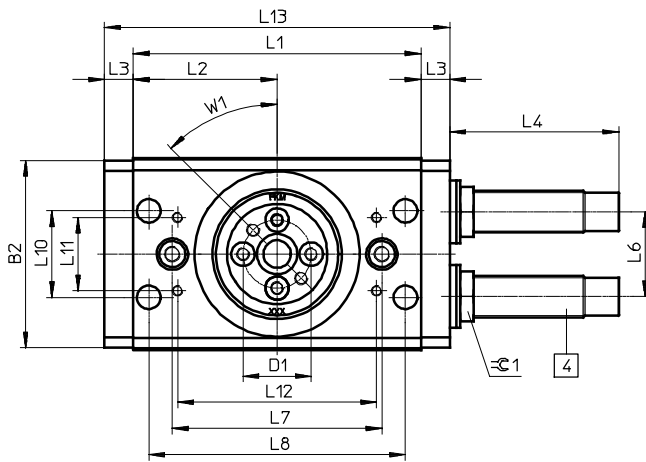
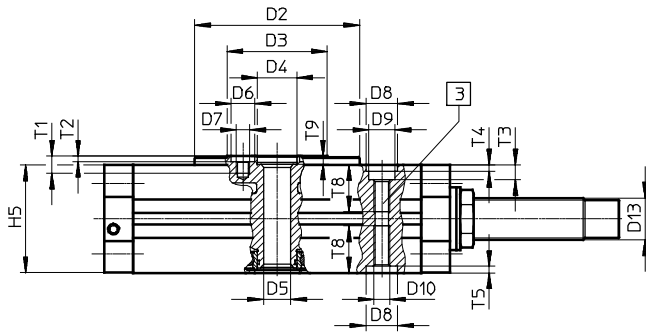

DRRD-32 ... 40

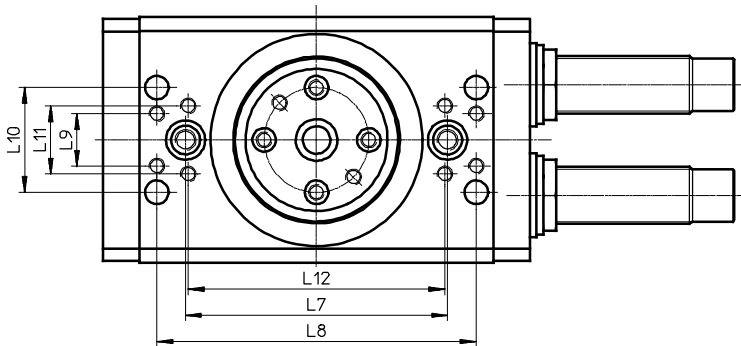

DRRD-...-P

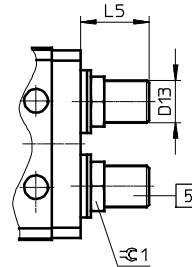

- 1 Sensor slot for proximity sensor
- 2 Supply ports
- 3 Mounting thread
- 4 Shock absorber (DRRD-...-Y9/-Y10)
- 5 Cushioning component (DRRD-...-P)

Dimensions

Download CAD data → www.festo.com

1

Size	B1 ±0.25	B2	D1 ∅ ±0.025	D2 ∅ h7	D3 ∅	D4 ∅	D5 ∅ +0.15/-0.05	D6 ∅ H7	D7	D8 ∅ H7	D9 ∅
16	58	56.2	21	50	32	12	8	7	M4	9	8
20	65	63.4	24	56	34.9	12	8	7	M4	9	8
25	73.2	71.5	26	63	38.3	15	10.5	9	M5	12	10
32	94	92.6	40	81	54.2	15	10.5	9	M6	15	11
35	106	104	45	91	59.9	25	10.5	9	M6	15	11
40	113	111	45	91	59.9	25	21	9	M6	15	14

Size	D10	D11 ∅ H7	D12	D13	H1 ±0.1	H2 +0.2/-0.1	H3 +0.3/-0.2	H4	H5	L1 ±0.1	L2
16	M5	7	M3	M10x1	33	35.6	2.6	0.5	32.6	84	42
20	M5	9	M4	M12x1	36	39.6	3.6	0.5	35.6	86	43
25	M6	9	M4	M16x1	41.4	44.7	3.3	0.5	41	110	55
32	M8	9	M6	M22x1.5	50	55.5	5.5	1	49.6	135	67.5
35	M8	9	M6	M26x1.5	63	67	4	1	62.2	148	74
40	M10	9	M6	M26x1.5	68	72	4	1	67.2	199	99.5

Size	L3 ±0.1	L6	L7 ±0.02	L8 ±0.2	L9 ±0.15	L10 ±0.02	L11 ±0.15	L12 ±0.2	L13	L14	L15 -0.1
16	10.5	23.2	64	74	-	26	22	61	105	20	16.3
20	11	26	70	74	-	33	14	80	108	20	17.8
25	11	32.4	80	98	-	33	14	98	132	20	20.5
32	14	42.2	100	122	20	40	26	98	163	30	24.8
35	15	49.6	120	130	44	26	44	105	178	42	31.1
40	15	56	120	130	44	26	44	105	229	42	33.6

Size	T1	T2 +0.1	T3	T4 +0.1	T5 +0.3/-0.2	T6	T7 +0.1	T8	T9	EE	W1	≈ 1
16	5.6	1.6	4.7	2.1	2.1	6.3	1.6	15	2.6	M5	45°	13
20	6	1.6	4.7	2.1	2.1	6.3	2.1	15	2.6	M5	45°	15
25	6.6	2.1	5.7	2.6	2.6	7	2.1	18	3.1	M5	45°	19
32	8	2.1	6.5	3.1	3.1	7.8	2.1	23.1	3.1	G $\frac{1}{8}$	45°	27
35	8	2.1	6.5	3.1	3.1	8.5	2.1	22.6	3.5	G $\frac{1}{8}$	45°	32
40	8	2.1	8.6	3.1	3.1	9	2.1	32	3.5	G $\frac{1}{8}$	45°	32

Size	Dimension with 180° swivel angle		Swivel angle adjustment range		
	L4	L5	L4 min./max.	L5 min./max.	1 mm = ...°
16	37	17.6	-20/+1.5	-12/+1.4	8.7
20	41.8	18	-21.1/+1.5	-11/+1.4	9
25	63	24.3	-28.9/+1.9	-15/+1.8	6.6
32	78.3	29.5	-34.7/+2.4	-19/+2.3	5.6
35	97.5	40.9	-34.7/+2.4	-27/+2.3	5.6
40	98.2	41.6	-53/+3.2	-28/+3.1	3.6

Semi-rotary drives DRRD, twin pistons

FESTO

Download CAD data → www.festo.com

Dimensions

1

Y12 – With external shock absorber

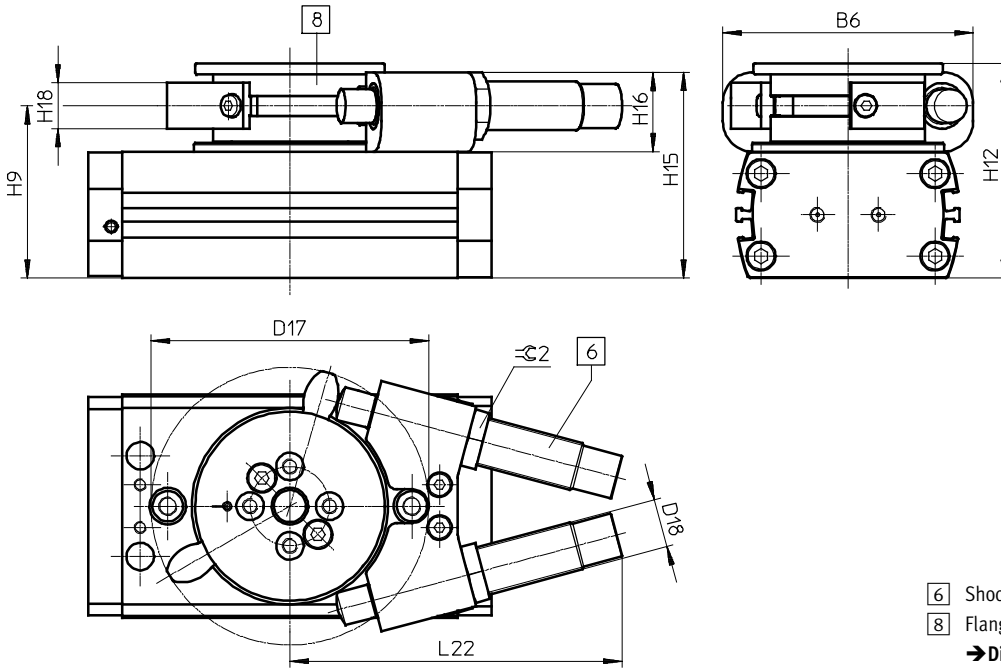

- 6 Shock absorber
- 8 Flange assembly:

→ Dimensions online: → [drdd](#)

Size	B6	D17	D18	H9	H12	H15	H16	H18	L22	±0.2
					+0.3/-0.2					
16	58	69.4	M10x1	43.1	52.6	51	18	10	65.2	13
20	75	91	M12x1	51.2	65.2	59.5	23.5	15	85.3	15
25	82	91	M16x1	56.5	70.3	67.4	26	15	108.9	19
32	120	126.2	M22x1.5	68.5	87	85	35	22	149.7	27
35	133	146.7	M26x1.5	83	101	99	36	21	155.5	27
40	133	146.7	M30x1.5	88	106	104	36	21	155.5	27



- Compact swivel modules with adjustable swivel angles up to 240°
- Flexible cushioning rings in the end positions
- With mounting flange
- Spare parts service
- Selected types in accordance with the ATEX Directive for explosive atmospheres → www.festo.com/catalogue/ex

→ www.festo.com/catalogue/dsm

Product range overview

Type/function	Version	Size	Swivel angle [°]	Torque [Nm]	Product options			
					P	A	FF	FW
Double-acting	DSM							
	With fixed swivel angle	6, 8	90, 180	0.15 ... 0.35	■	■	-	■
		10	90, 180, 240	0.85	■	■	-	■
	DSM-...-FF							
	With adjustable swivel angle	6, 8	180	0.15 ... 0.35	■	■	■	■
		10	200	0.85	■	■	■	■
	DSM-T-...							
	With tandem rotary vanes	6, 8	90, 180	0.3 ... 0.7	■	■	■	■
10		90, 180, 240	1.7	■	■	■	■	

Product options

P	Elastic cushioning components at both ends	A	Position sensing	FF	Adjustable swivel angle	FW	Flanged shaft
---	--	---	------------------	----	-------------------------	----	---------------

Swivel modules DSM-6 ... 10

Technical data

1

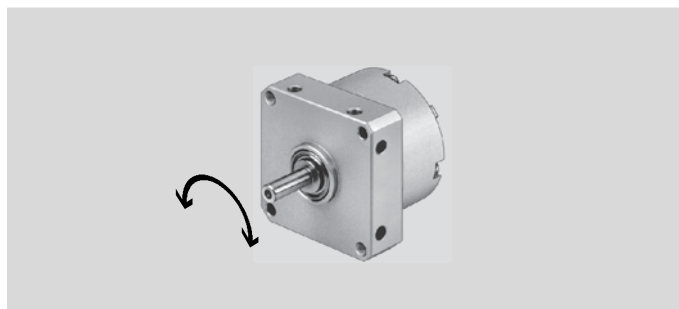

Technical data			Dimensions → 199		
Size			6	8	10
Pneumatic connection			M3		
Cushioning			Elastic cushioning components at both ends		
Swivel angle	Fixed	[°]	90 or 180	90 or 180	90, 180 or 240
	Adjustable	[°]	0 ... 180		0 ... 200
Torque at 6 bar		[Nm]	0.15	0.35	0.85
Max. perm. swivel frequency		[Hz]	3		3 (at 240°: 2 Hz)
Max. perm. radial force ¹⁾		[N]	15	20	30
Max. perm. axial force ¹⁾		[N]	10		
Max. cushioning angle		[°]	0.5		
Max. perm. mass moment of inertia ²⁾		[kgm ²]	0.00065	0.0013	0.0026

1) On the drive shaft.
 2) Maximum value → Graphs.

Operating conditions					
Size			6	8	10
Operating pressure		[bar]	3.5 ... 8		2.5 ... 8
Temperature range ³⁾		[°C]	0 ... +60		

3) Note operating range of proximity sensors.

Materials		
Drive shaft		High-alloy stainless steel
End cap		Aluminium
Housing		Anodised aluminium
Rotary vane		Glass fibre-reinforced plastic
Screws		Galvanised steel
Seals		NBR, TPE-U (PUR)

Technical data

Mass moment of inertia J on the drive shaft as a function of swivel time t

DSM-6

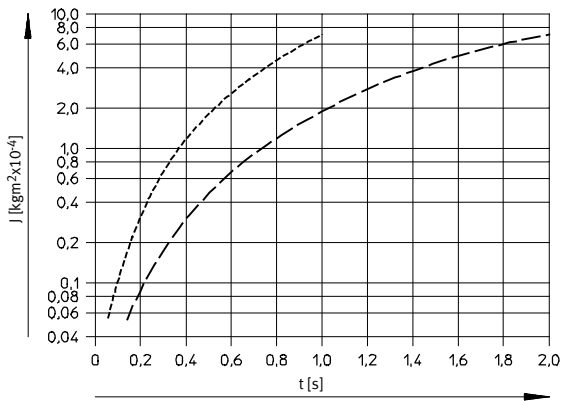

DSM-8

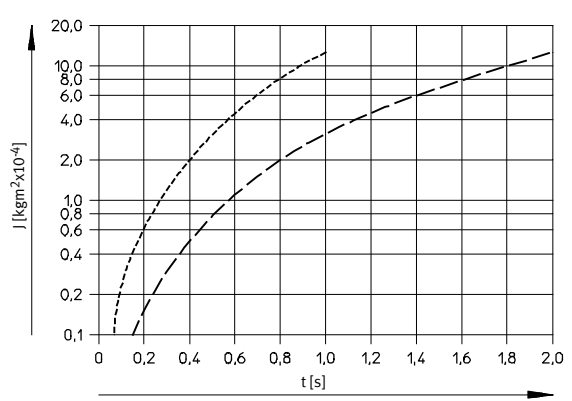

DSM-10

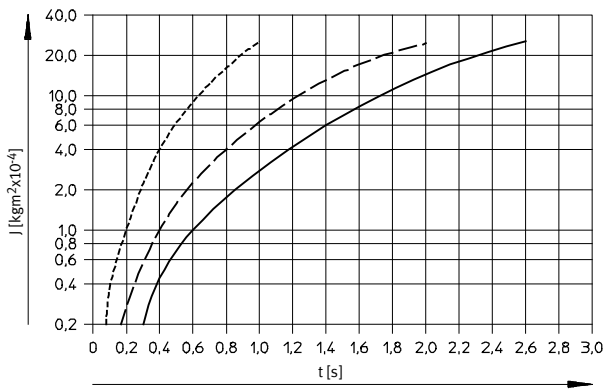

- - - 90°
- - - 180°
- 240°

Swivel modules DSM-6 ... 10

1

Order code

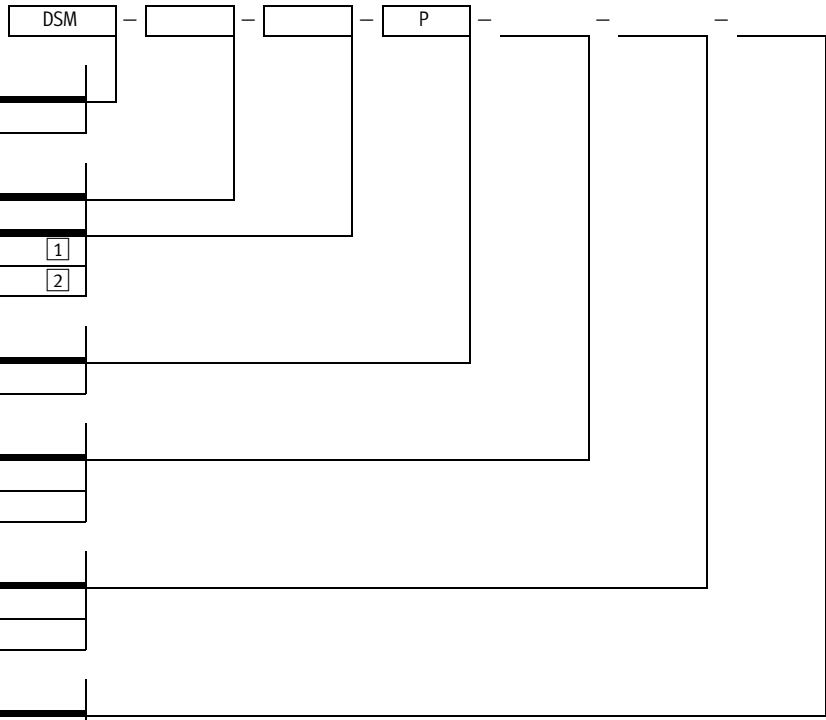

Type	
DSM	Swivel module
Size	
	Max. swivel angle [°]
6, 8	90, 180 1
10	90, 180, 240 2
Cushioning	
P	Elastic cushioning components at both ends
Position sensing	
-	None
A	Via proximity sensor
Swivel angle	
-	Fixed
FF	Adjustable
Shaft	
-	Spigot shaft
FW	Flanged shaft

- 1 With adjustable swivel angle only 180°.
- 2 With adjustable swivel angle only 200°.

Ordering – Product options

Configurable product

This product and all its options can be ordered using the configurator.

The configurator can be found under Products on the DVD or
[→ www.festo.com/catalogue/...](http://www.festo.com/catalogue/...)

Enter the type code in the search field.

Accessories

1

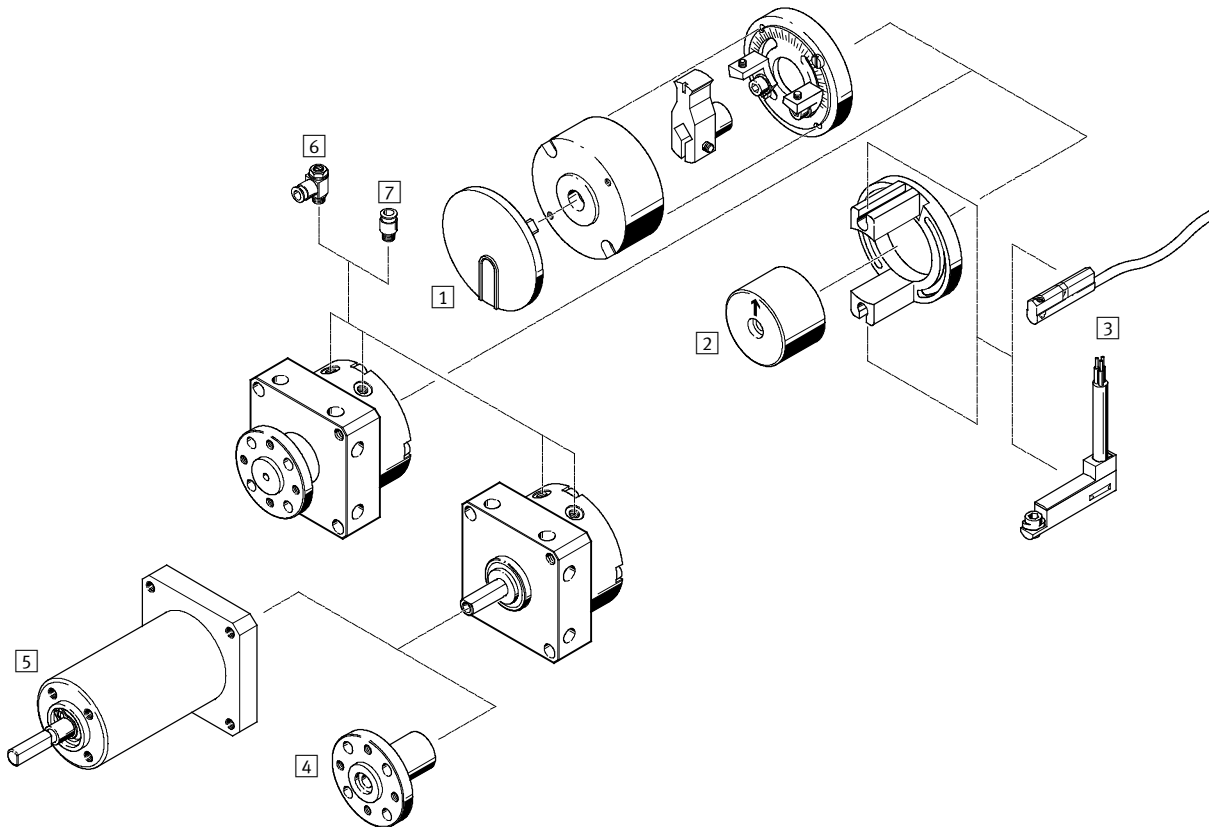



		→ Page/online
1	Stop kit KSM	198
2	Mounting kit WSM-...-SME-10	198
3	Proximity sensor SME-/SMT-10	198
4	Push-on flange FWSR	198
5	Freewheel unit FLSM	198
6	One-way flow control valve GRLA	198
-	Drive/gripper connections	adapter kit
-	Kit accessories DSM	198

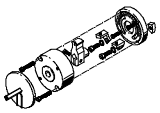

Swivel modules DSM-6 ... 10

1

Accessories – Ordering data

	For size	Part No.	Type
1 Stop kit			
	6	175833	KSM-6
	8	175834	KSM-8
	10	175835	KSM-10

	For size	Part No.	Type
2 Mounting kit for proximity sensor			
	6	173505	WSM-6-SME-10
	8	173606	WSM-8-SME-10
	10	173206	WSM-10-SME-10

	For size	Part No.	Type	
3 Proximity sensor for C-slot, magneto-resistive – N/O contact				Technical data → 749
	PNP, cable	★ 551373	SMT-10M-PS-24V-E-2,5-L-OE	
	PNP, plug	★ 551375	SMT-10M-PS-24V-E-0,3-L-M8D	
Magnetic reed – N/O contact				Technical data → 745
	Plug	★ 551367	SME-10M-DS-24V-E-0,3-L-M8D	
	Cable	★ 551365	SME-10M-DS-24V-E-2,5-L-OE	
	Cable	★ 551369	SME-10M-ZS-24V-E-2,5-L-OE	
				Technical data → 747
	Cable	173210	SME-10-KL-LED-24	
	Cable	173211	SME-10-KQ-LED-24	
	Plug	173212	SME-10-SL-LED-24	
	Plug	773213	SME-10-SQ-LED-24	

	For size	Part No.	Type	
4 Push-on flange				Dimensions online: → dsm
	6	185948	FWSR-6	
	8	32798	FWSR-8	
	10	185949	FWSR-10	

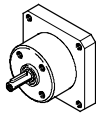
	For size	Direction of rotation ¹⁾	Part No.	Type	
5 Freewheel unit					Dimensions online: → dsm
	6	Anti-clockwise rotation	188253	FLSM-6-L	
		Clockwise rotation	188522	FLSM-6-R	
	8	Anti-clockwise rotation	188525	FLSM-8-L	
		Clockwise rotation	188524	FLSM-8-R	
	10	Anti-clockwise rotation	188527	FLSM-10-L	
		Clockwise rotation	188526	FLSM-10-R	

1) Viewed towards drive shaft side.

Function	For size	Connection	Part No.	Type
		Thread	O.D.	
6 One-way flow control valve with slotted head screw, metal²⁾ for exhaust air flow control				
	6, 8, 10	M3	3	175041 GRLA-M3-QS-3

2) The recommended flow control valves are based on a tubing length to the valve of 1 m. For deviations of ±50%, flow control valves with a bigger or smaller flow rate must be selected to guarantee the optimum flow control function and cylinder speed.

For size	Comment	Part No.	Type
Kit accessories			
6	Adapter for attaching the stop kit	175830	DSM-6-180-P-A-FF
8	KSM or mounting kit	175831	DSM-8-180-P-A-FF
10	WSM-....-SME-10	175832	DSM-10-240-P-A-FF
6	Socket head screw for attaching the stop kit KSM or mounting kit	–	DIN 84-M2x25-4.8
8		–	DIN 84-M2x30-4.8
10	WSM-....-SME-10	–	M2.5x32 ³⁾

3) Screw similar to DIN 84.

Dimensions

With spigot shaft and fixed stop – Size 6 ... 10

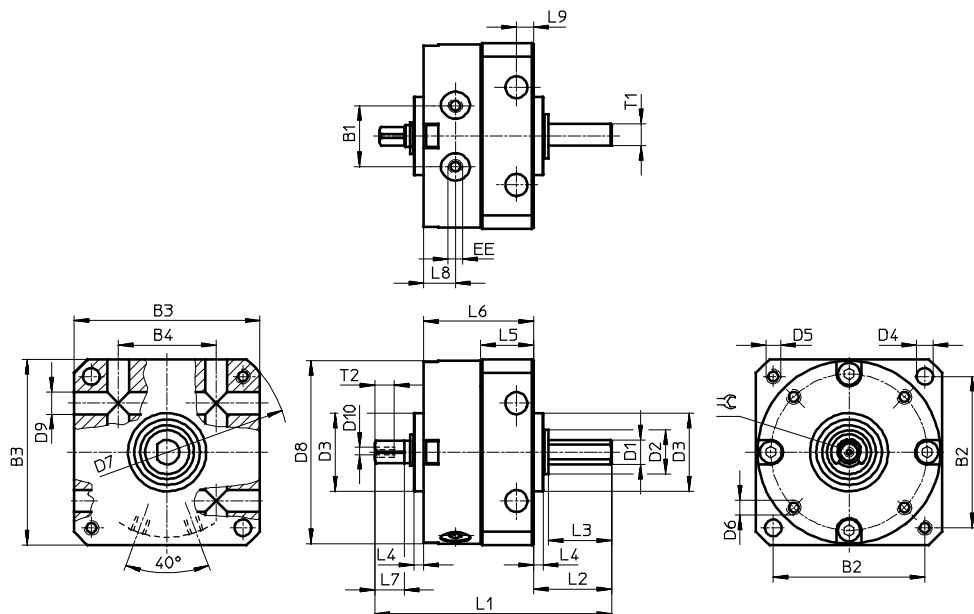

Ø 10

Shaft position

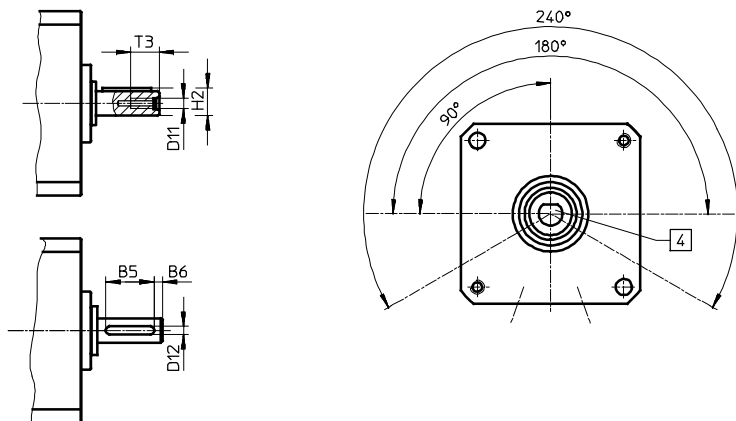

Note
For swivel angle tolerance → table below. The supply ports are at the bottom in this drawing.

Size	B1	B2	B3	B4	B5	B6	D1 ∅ g7	D2 ∅	D3 ∅ f8	D4 ∅ H12	D5	D6	D7 ∅ H12	D8 ∅	D9 ∅ H12	D10	D11	D12 h9
6	10	25	30	17	–	–	4	8	14	3.2	M3	M2	40	29.4	3.5	M2	–	–
8	12.8	31	38	20	–	–	5	9	16	3.2	M3	M2.5	50	37.4	3.5	M2	–	–
10	15.9	38	47	26	12	2	6	12	19	4.3	M4	M3	62	46.4	4.5	M2.5	M2.5	2

Size	EE	H2 max.	L1	L2	L3	L4	L5	L6	L7	L8	L9	T1	T2 h12	T3	∠	Swivel angle tolerance
6	M3	–	43	13	10	2	9.8	21	5	6	3	3.5	4	–	3	0/+5°
8	M3	–	50	16	13	2	11.3	23	6	6.5	3	4.5	4.3	–	3.5	0/+5°
10	M3	6.8	61	19.6	16	2	14.3	28.4	8	7.5	4	–	5	7	4.5	0/+5°

Swivel modules DSM-6 ... 10

Dimensions

1 With spigot shaft, fixed stop and position sensing – Size 6 ... 10

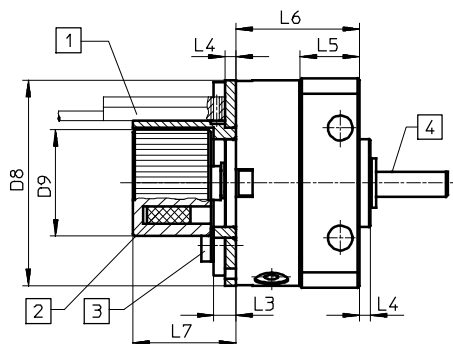

- 1 Proximity sensor not included in the scope of delivery. Observe fitting space for proximity sensor and cable
- 2 Magnet position
- 3 Max. tightening torque for sensor bracket screws → table below
- 4 The flat or the feather key on the shaft indicates the position of the rotary vane

Size	D8 ∅	D9 ∅	L3	L4	L5	L6	L7	Tightening torque [Nm]
6	29.4	17.3	4	2	9.8	21	19.5	0.19
8	37.4	19.3	4	2	11.3	23	19.5	0.32
10	46.4	22.3	4	2	14.3	28	19.5	0.44

Dimensions

Download CAD data → www.festo.com

With spigot shaft, fixed stop and adjustable swivel angle – Size 6 ... 10

Note
The swivel angle is infinitely adjustable over the entire swivel range.
Size 6 can only be adjusted symmetrically around the centre position.

- 1 Supply ports
- 2 Locking screw for clamping the stop
- 3 End-position adjustment
- 4 Lock nut for end-position adjustment
- 5 Infinitely adjustable stops

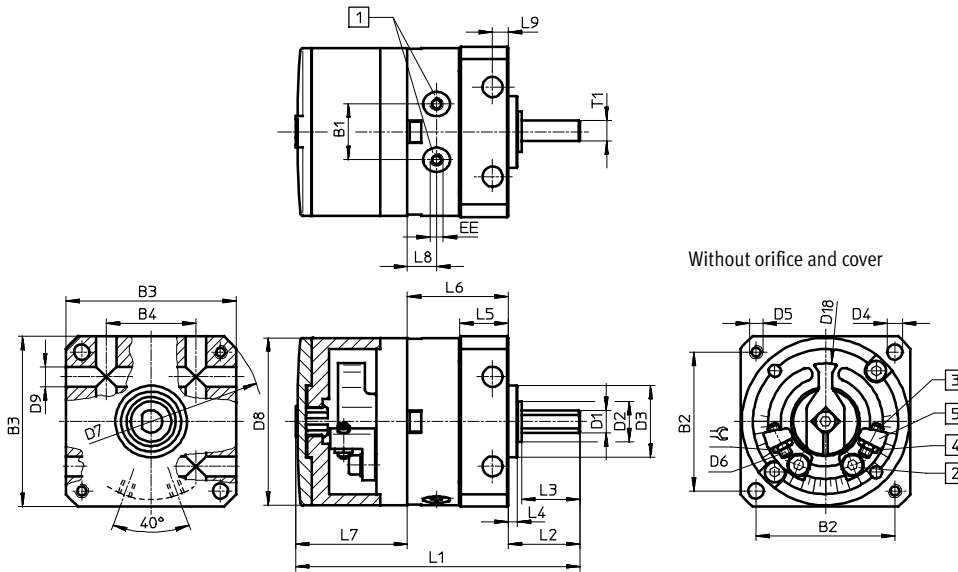

Size	B1	B2	B3	B4	D1 Ø g7	D2 Ø	D3 Ø f8	D4 Ø H12	D5	D6	D7 Ø H12	D8 Ø	D9 Ø H12	D18 Ø	EE
6	10	25	30	17	4	8	14	3.2	M3	M2	40	29.4	3.5	22	M3
8	12.8	31	38	20	5	9	16	3.2	M3	M2.5	50	37.4	3.5	26	M3
10	15.9	38	47	26	6	12	19	4.3	M4	M3	62	46.4	4.5	35.8	M3

Size	L1	L2	L3	L4	L5	L6	L7	L8	L9	T1	≈	Max. swivel angle	Precision adjustment per end
6	52	13	10	2	9.8	21	17.8	6	3	3.5	4	180°+5°	+1°/-5°
8	64	16	13	2	11.3	23	24.9	6.5	3	4.5	5	180°+5°	+1°/-5°
10	76	19.6	16	2	14.3	28.4	28.2	7.5	4	-	5.5	200°+5°	+1°/-5°

With spigot shaft, fixed stop, adjustable swivel angle and position sensing – Size 6 ... 10

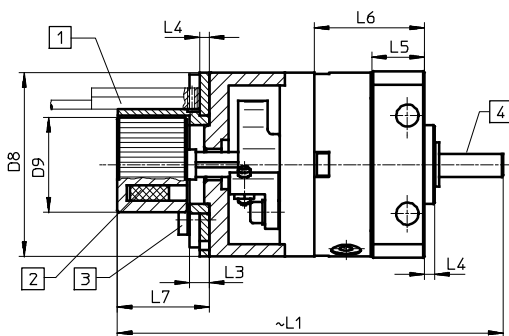

- 1 Sensor not included in the scope of delivery. Observe fitting space for proximity sensor and cable
- 2 Magnet position
- 3 Max. tightening torque for sensor bracket screw → table below
- 4 The flat or the feather key on the shaft indicates the position of the rotary vane

Size	D8 Ø	D9	L1	L3	L4	L5	L6	L7	Tightening torque [Nm]
6	29.4	17.3	68.5	4	2	9.8	21	19.5	0.19
8	37.4	19.3	80	4	2	11.3	23	19.5	0.32
10	46.4	22.3	91.5	4	2	14.3	28.4	19.5	0.44

Swivel modules DSM-6 ... 10

Dimensions

1 With flanged shaft and fixed stop – Size 6 ... 10

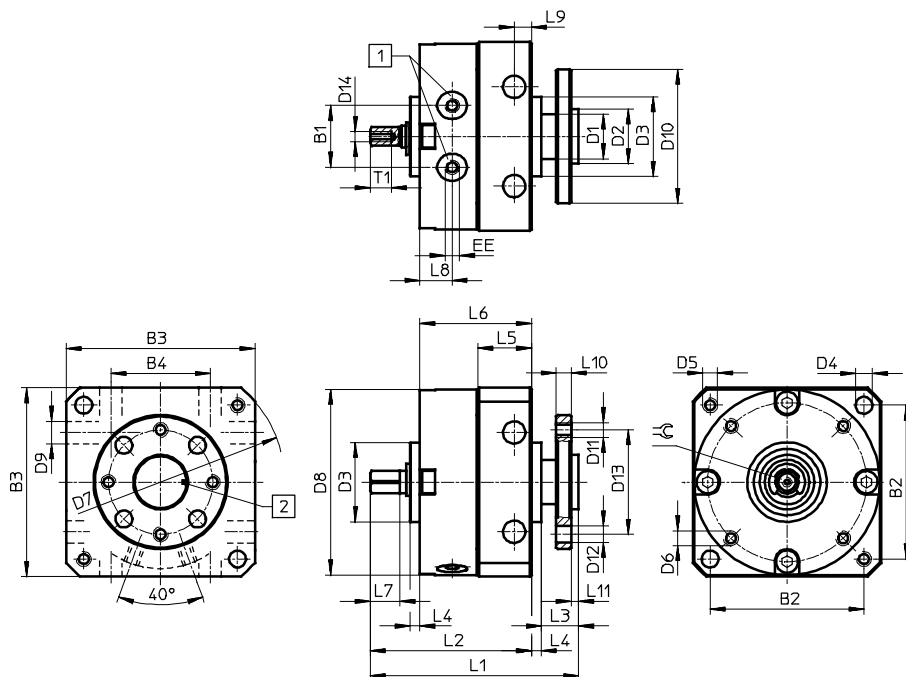

- 1 Supply ports
- 2 Mark indicating rotary vane position

Size	B1	B2	B3	B4	D1 ∅	D2 ∅ g7	D3 ∅ f8	D4 ∅	D5	D6	D7 ∅ H12	D8 ∅	D9 ∅ H12	D10 ∅	D11	D12 ∅ H13	D13 ∅
6	10	25	30	17	8	8	14	3.2	M3	M2	40	29.4	3.5	23	M3	3.4	16
8	12.8	31	38	20	9	11	16	3.2	M3	M2.5	50	37.4	3.5	27	M3	3.4	21
10	15.9	38	47	26	10	11	19	4.3	M4	M3	62	46.4	4.5	30	M3	3.4	21

Size	D14	EE	L1	L2	L3	L4	L5	L6	L7	L8	L9	L10	L11	T1	≈	Swivel angle tolerance
6	M2	M3	39.5	30	7.5	2	9.8	21	5	6	3	3	1.5	4	3	0/+5°
8	M2	M3	43.5	34	7.5	2	11.3	23	6	6.5	3	3	1.5	4.3	3.5	0/+5°
10	M2.5	M3	53	41.4	9.6	2	14.3	28.4	8	7.5	4	3	1.6	5	4.5	0/+5°

With flanged shaft, fixed stop and position sensing – Size 6 ... 10

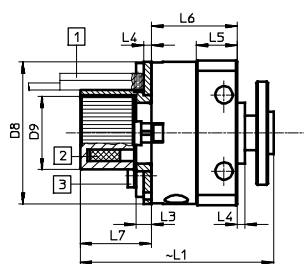

- 1 Proximity sensor not included in the scope of delivery. Observe fitting space for proximity sensor and cable
- 2 Magnet position
- 3 Max. tightening torque for sensor bracket screw → table below

Size	D8 ∅	D9 ∅	L1	L3	L4	L5	L6	L7	Tightening torque [Nm]
6	29.4	17.3	50	4	2	9.8	21	19.5	0.19
8	37.4	19.3	52	4	2	11.3	23	19.5	0.32
10	46.4	22.3	59.5	4	2	14.3	28.4	19.5	0.44

Dimensions

With flanged shaft, fixed stop and adjustable swivel angle – Size 6 ... 10

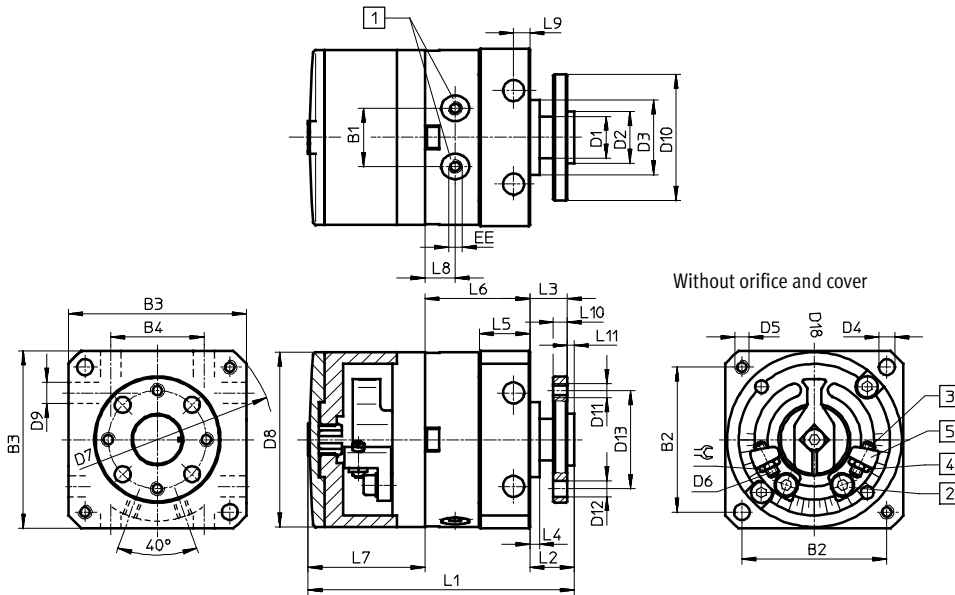

Note

The swivel angle is infinitely adjustable over the entire swivel range. Size 6 can only be adjusted symmetrically around the centre position.

- 1 Supply ports
- 2 Locking screw for clamping the stop
- 3 End-position adjustment
- 4 Lock nut for end-position adjustment
- 5 Infinitely adjustable stops

Size	B1	B2	B3	B4	D1 ∅	D2 ∅ g7	D3 ∅ f8	D4 ∅ H12	D5	D6	D7 ∅ H12	D8 ∅
6	10	25	30	17	8	8	14	3.2	M3	M2	40	29.4
8	12.8	31	38	20	9	11	16	3.2	M3	M2.5	50	37.4
10	15.9	38	47	26	10	11	19	4.3	M4	M3	62	46.4

Size	D9 ∅ H12	D10 ∅	D11	D12 ∅ H13	D13 ∅	D18 ∅	EE	L1	L2	L3	L4
6	3.5	23	M3	3.4	16	22	M3	48	9.5	8	2
8	3.5	27	M3	3.4	21	26	M3	58	9.5	8	2
10	4.5	30	M3	3.4	21	35.8	M3	68	11.6	10	2

Size	L5	L6	L7	L8	L9	L10	L11	⊕	Max. swivel angle	Precision adjustment per end
6	9.8	21	17.8	6	3	3	1.5	4	180° +5°	+1°/-5°
8	11.3	23	24.9	6.5	3	3	1.5	5	180° +5°	+1°/-5°
10	14.3	28.4	28.2	7.5	4	3	1.6	5.5	200° +5°	+1°/-5°

Swivel modules DSM-6 ... 10

Dimensions

1 With flanged shaft, fixed stop, adjustable swivel angle and position sensing – Size 6 ... 10

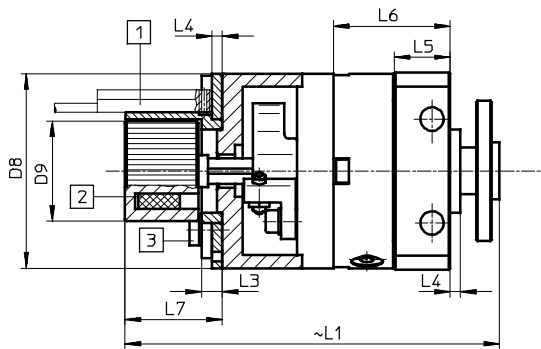

Note

The swivel angle is infinitely adjustable over the entire swivel range. Size 6 can only be adjusted symmetrically around the centre position.

- 1 Proximity sensor not included in the scope of delivery. Observe fitting space for proximity sensor and cable
- 2 Magnet position
- 3 Max. tightening torque for sensor bracket screws → table below

Size	D8 Ø	D9 Ø	L1	L3	L4	L5	L6	L7	Tightening torque [Nm]
6	29.4	17.3	65	4	2	9.8	21	19.5	0.19
8	37.4	19.3	73.5	4	2	11.3	23	19.5	0.32
10	46.4	22.3	83	4	2	14.3	28.4	19.5	0.44



- Swivel modules with minimum space requirement
- Swivel modules with tandem rotary vanes
- Simple basic and precision adjustment of the swivel angle
- High-performance cushioning
- Compact, low-cost sensing
- ★ Quick ordering of basic designs → 211

→ www.festo.com/catalogue/dsm

Product range overview

Type/function	Version	Size	Swivel angle [°]	Torque [Nm]	Product options					
					P	P1	CC	–	FW	A
Double-acting	DSM- ... -B									
	Basic design	12, 16, 25, 32, 40, 63	270	1.25 ... 40	■	–	–	■	■	■
		12, 16, 25, 32	246	1.25 ... 10	–	■	■	■	■	■
		40, 63	240	20 ... 40	–	■	■	■	■	■
	DSM-T- ... -B									
	Tandem rotary vanes	12, 16, 25, 32, 40, 63	270	2.5 ... 80	■	–	–	■	■	■
		12, 16, 25, 32	246	2.5 ... 20	–	–	■	■	■	■
		40, 63	240	40 ... 80	–	–	■	■	■	■
	DSM- ... -HD- ... -B									
	Heavy-duty bearing	12, 16, 25, 32, 40, 63	270	1.25 ... 40	–	–	–	–	–	■
		12, 16, 25, 32	246	1.25 ... 10	–	■	■	–	–	■
		40, 63	240	20 ... 40	–	■	■	–	–	■

Product options

P	Elastic cushioning components at both ends, with fixed stop	P1	Adjustable elastic cushioning components at both ends, with fixed stop	CC	Self-adjusting shock absorber at both ends, with fixed stop	FW	Flanged shaft
				–	Shaft with feather key	HD	Heavy-duty bearing
						A	Position sensing
						B	B series

Swivel modules DSM-12 ... 63-B

FESTO

1 Technical data

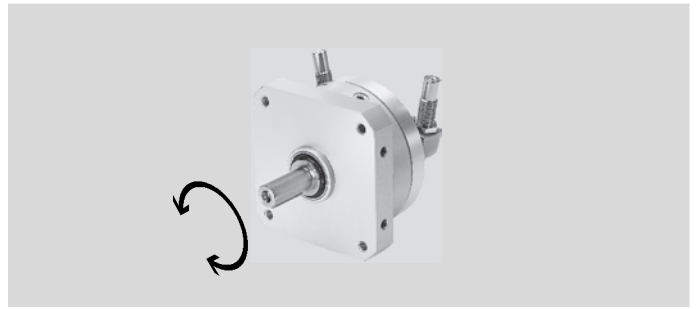

Technical data							Dimensions → 216
Size		12	16	25	32	40	63
Pneumatic connection		M5			G1/8		G1/4
Cushioning							
DSM-...-P		Elastic cushioning components at both ends					
DSM-...-P1		Adjustable elastic cushioning components at both ends					
DSM-...-CC		Self-adjusting shock absorber at both ends					
Torque at 6 bar							
DSM-...	[Nm]	1.25	2.5	5	10	20	40
DSM-...-T	[Nm]	2.5	5	10	20	40	80
Swivel angle							
DSM-...-P	[°]	270/262 ¹⁾		270			
DSM-...-P1	[°]	246				240	
DSM-...-CC	[°]	246				240	
Swivel frequency (at max. swivel angle)							
DSM-...-P	[Hz]	2					1.6
DSM-...-P1	[Hz]	2					1.6
DSM-...-CC	[Hz]	1.5	1		0.7		0.6
Max. perm. radial load ²⁾	[N]	45	75	120	200	350	500
Max. perm. axial load ²⁾	[N]	18	30	50	75	120	500
Max. cushioning angle							
DSM-...-P1	[°]	10	9	7.5	6.5	6.5	6
DSM-...-CC	[°]	15	12	10	12	16	17.5
Max. perm. mass moment of inertia	[kgm ²]	→ 207					

1) Restricted swivel angle in combination with sensor bracket SL-DSM-S-...

2) On the drive shaft.

Operating conditions							
Size		12	16	25	32	40	63
Operating pressure							
DSM-...	[bar]	2 ... 10	1.8 ... 10		1.5 ... 10		
DSM-...-T	[bar]	2.5 ... 10		2 ... 10			
Ambient temperature ³⁾	[°C]	-10 ... +60					

3) Note operating range of proximity sensors.

Materials	
Drive shaft	Nickel-plated steel
Housing	Anodised aluminium
Flange	Anodised aluminium
Stop lever	Anodised aluminium
Rotary vane	Glass fibre-reinforced plastic
Fixed stops	Galvanised steel
Seals	TPE-U (PUR)

Technical data

Mass moment of inertia J on the drive shaft as a function of swivel time t
 With elastic cushioning components (P)

DSM-12-270-P-...

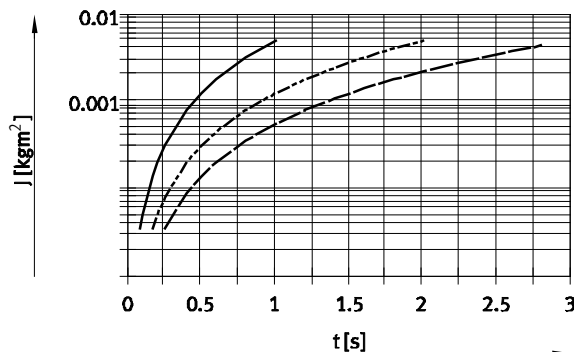

DSM-16-270-P-...

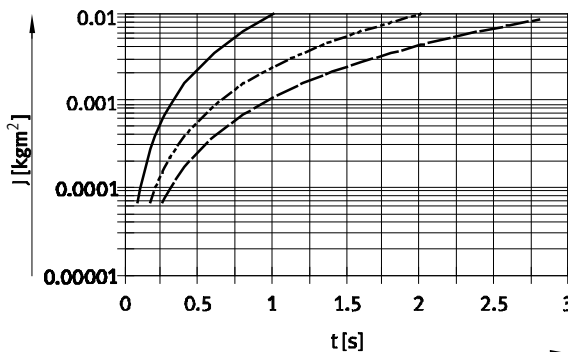

DSM-25-270-P-...

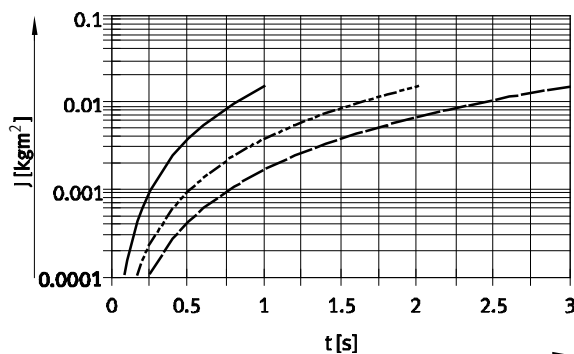

DSM-32-270-P-...

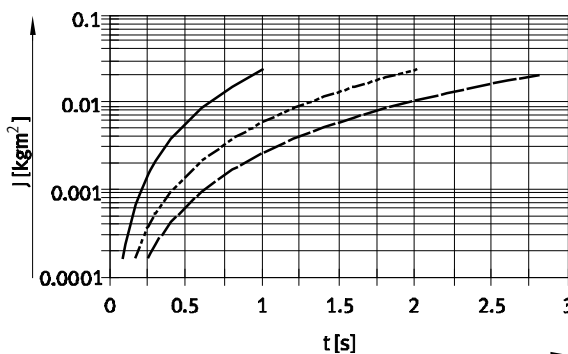

DSM-40-270-P-...

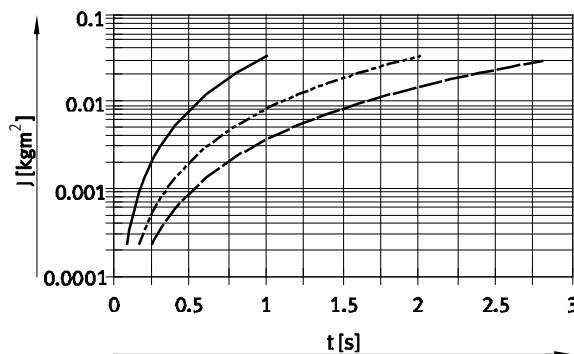

DSM-63-270-P-...

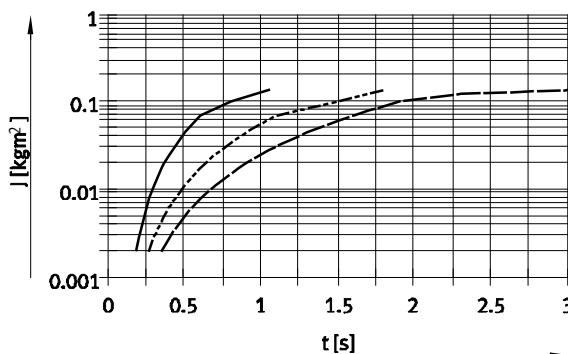

- 90°
- - - 180°
- · - 270°

Note
 Sizing software for calculating mass moment of inertia
 → www.festo.com

Swivel modules DSM-12 ... 63-B

Technical data

1

Mass moment of inertia J on the drive shaft as a function of swivel time t

With adjustable, elastic cushioning components (P1)

DSM-12-270-P1-...

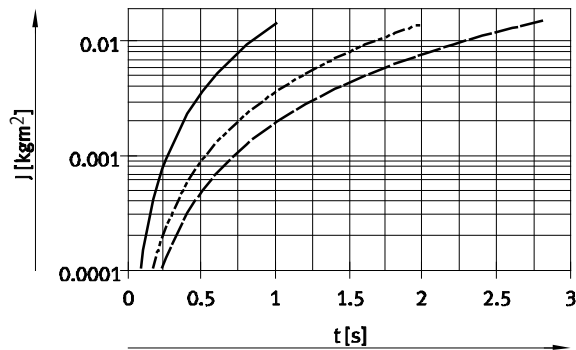

DSM-16-270-P1-...

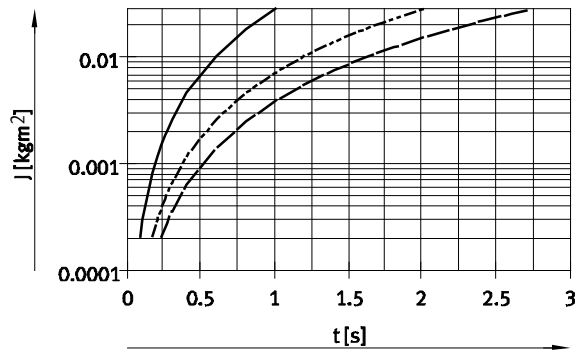

DSM-25-270-P1-...

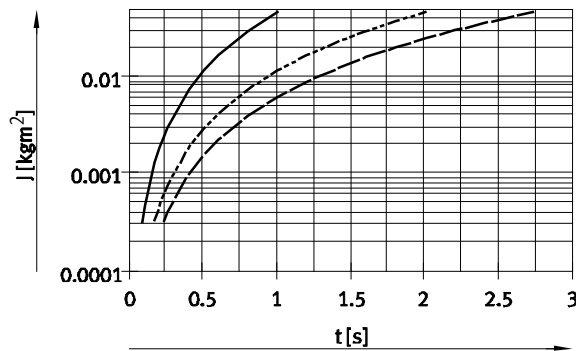

DSM-32-270-P1-...

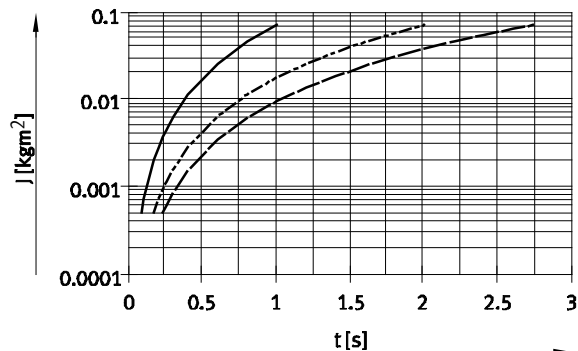

DSM-40-270-P1-...

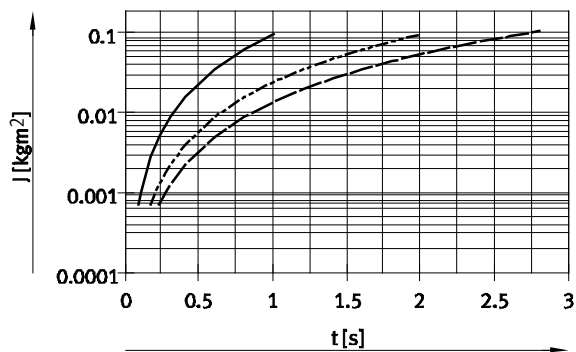

DSM-63-270-P1-...

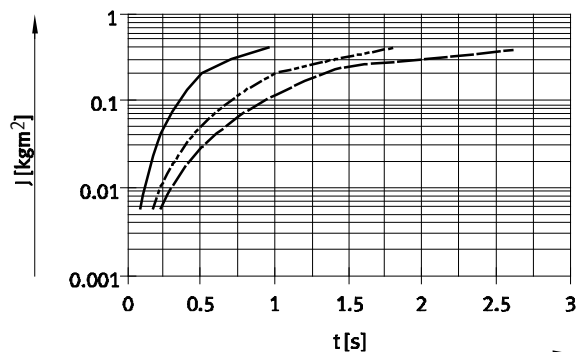

- 90°
- - - 180°
- · - 240°

Technical data

Mass moment of inertia J on the drive shaft as a function of swivel time t
With shock absorbers (CC)

DSM-12-270-CC-...

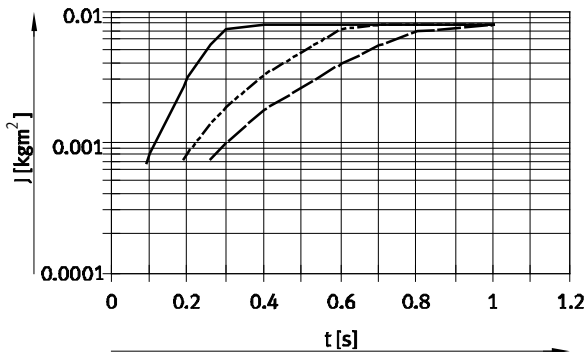

DSM-16-270-CC-...

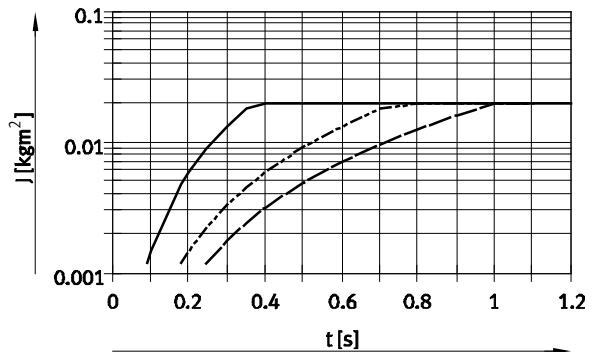

DSM-25-270-CC-...

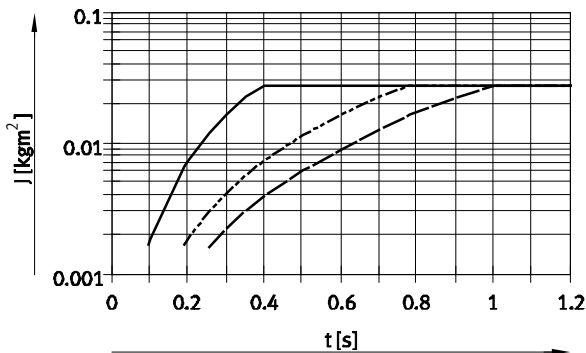

DSM-32-270-CC-...

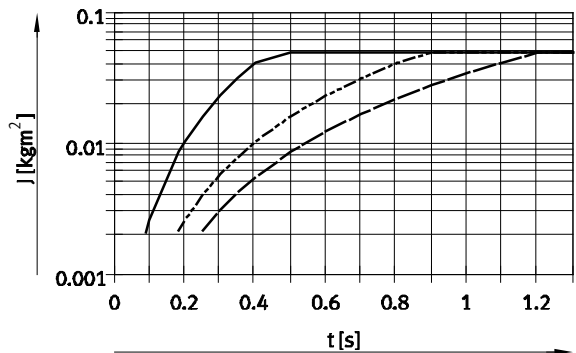

DSM-40-270-CC-...

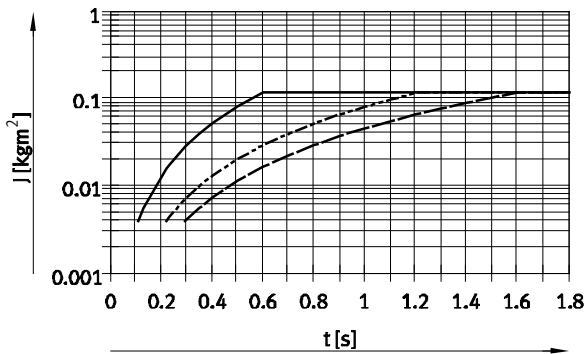

DSM-63-270-CC-...

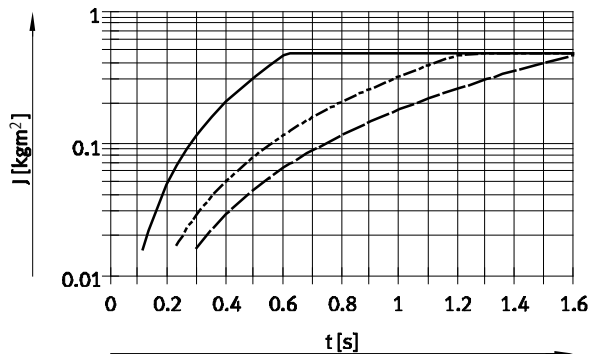

- 90°
- - - 180°
- · - 240°

The graphs for the DSM-...-CC show the swivel time up to the point where the stop lever meets the shock absorber. The cushioning time of the shock absorber must be added in order to obtain the total swivel time.

Cushioning time of the shock absorber

Size	12/16/25	32	40	63
Cushioning time [s]	0.1	0.25	0.3	0.4

Swivel modules DSM-12 ... 63-B

1

Order code

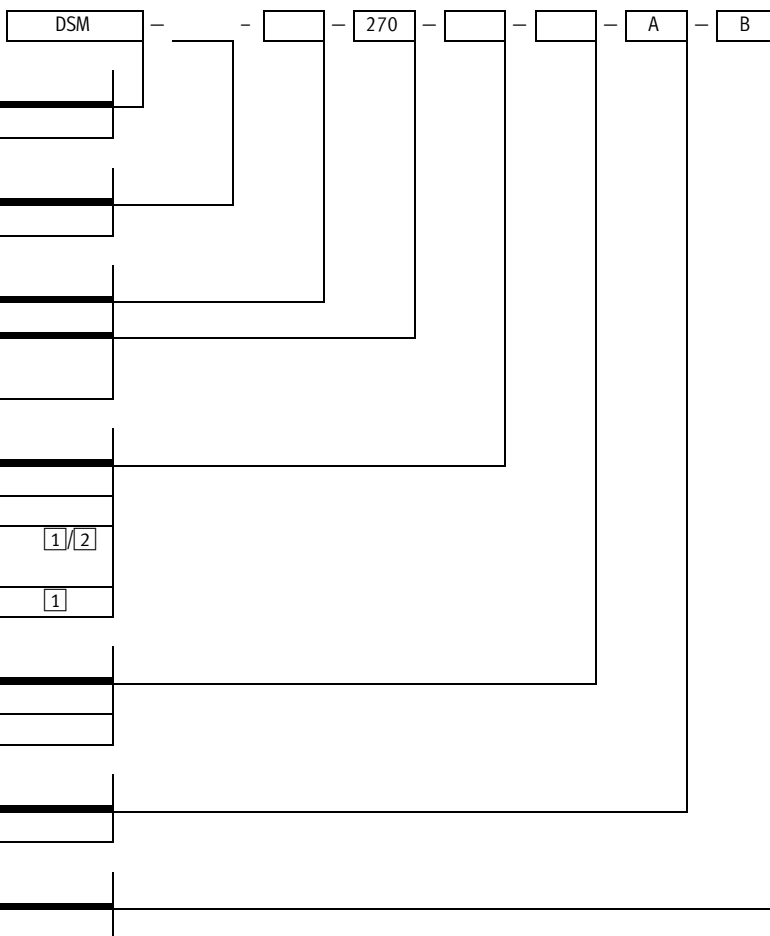

1 Max. swivel angle 246° with size 12 ... 32.
Max. swivel angle 240° with size 40, 63.

2 Not with tandem rotary vanes T.

Ordering – Product options

	<p>Configurable product</p>	<p>This product and all its options can be ordered using the configurator.</p>	<p>The configurator can be found under Products on the DVD or → www.festo.com/catalogue/...</p>	<p>Enter the type code in the search field.</p>
--	------------------------------------	---	---	---

★ Quick ordering

Spigot shaft			
Piston Ø	Swivel angle	Part No.	Type
Without cushioning components			
12	270°	547591	DSM-12-270-A-B
16		547592	DSM-16-270-A-B
25		547593	DSM-25-270-A-B
32		547594	DSM-32-270-A-B
40		547595	DSM-40-270-A-B
P – Elastic cushioning components at both ends			
12	270°	547570	DSM-12-270-P-A-B
16		547574	DSM-16-270-P-A-B
25		547578	DSM-25-270-P-A-B
32		547582	DSM-32-270-P-A-B
40		547586	DSM-40-270-P-A-B
P1 – Adjustable elastic cushioning components at both ends			
12	246°	566203	DSM-12-270-P1-A-B
16		566205	DSM-16-270-P1-A-B
25		566207	DSM-25-270-P1-A-B
32		566209	DSM-32-270-P1-A-B
40	240°	566211	DSM-40-270-P1-A-B
CC – Shock absorber at both ends			
12	246°	547572	DSM-12-270-CC-A-B
16		547576	DSM-16-270-CC-A-B
25		547580	DSM-25-270-CC-A-B
32		547584	DSM-32-270-CC-A-B
40	240°	547588	DSM-40-270-CC-A-B

Flanged shaft			
Piston Ø	Swivel angle	Part No.	Type
Without cushioning components			
12	270°	547596	DSM-12-270-FW-A-B
16		547597	DSM-16-270-FW-A-B
25		545598	DSM-25-270-FW-A-B
32		545599	DSM-32-270-FW-A-B
40		545600	DSM-40-270-FW-A-B
P-FW – Elastic cushioning components at both ends			
12	270°	547571	DSM-12-270-P-FW-A-B
16		547575	DSM-16-270-P-FW-A-B
25		547579	DSM-25-270-P-FW-A-B
32		547583	DSM-32-270-P-FW-A-B
40		547587	DSM-40-270-P-FW-A-B
P1-FW – Adjustable elastic cushioning components at both ends			
12	246°	566204	DSM-12-270-P1-FW-A-B
16		566206	DSM-16-270-P1-FW-A-B
25		566208	DSM-25-270-P1-FW-A-B
32		556210	DSM-32-270-P1-FW-A-B
40	240°	556212	DSM-40-270-P1-FW-A-B
CC-FW – Shock absorber at both ends			
12	246°	547573	DSM-12-270-CC-FW-A-B
16		547577	DSM-16-270-CC-FW-A-B
25		547581	DSM-25-270-CC-FW-A-B
32		547585	DSM-32-270-CC-FW-A-B
40	240°	547589	DSM-40-270-CC-FW-A-B

Swivel modules DSM-12 ... 63-B

Accessories

1

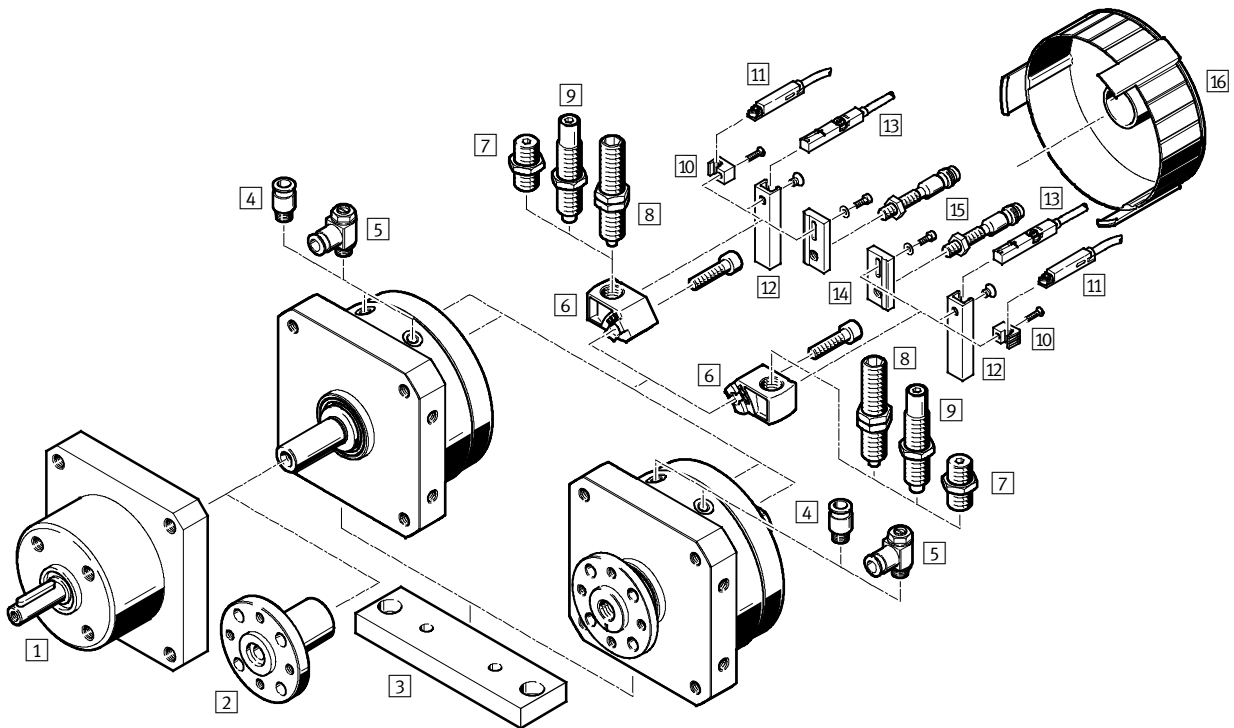

		→ Page/online
1	Freewheel unit FLSM	213
2	Push-on flange FWSR	213
3	Mounting plate HSM	213
4	Push-in fitting QS	908
5	One-way flow control valve GRLA	213
6	Cushioning mount DSM-...-B	213
7	Cushioning kit DSM-...-P-B (P cushioning)	213
8	Shock absorber DYEF (P1 cushioning)	213
9	Shock absorber DYSC (CC cushioning)	213
10	Sensor bracket SL-DSM-B	213
11	Proximity sensor SME-/SMT-10 for size 12 ... 40	214
12	Sensor bracket SL-DSM-63-B	213
13	Proximity sensor SME-/SMT-8 for size 63	214
14	Sensor bracket SL-DSM-S	213
15	Inductive proximity sensor SIEN	215
16	Cover cap AKM	215
-	Connecting cable NEBU	215
-	Drive/gripper connections	adapter kit

Accessories – Ordering data

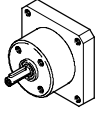

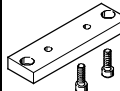
	For size	Direction of rotation ¹⁾	Part No.	Type
1 Freewheel unit	Dimensions online: → dsm			
	12	Anti-clockwise rotation	164229	FLSM-12-L
		Clockwise rotation	164234	FLSM-12-R
	16	Anti-clockwise rotation	164230	FLSM-16-L
		Clockwise rotation	164235	FLSM-16-R
	25	Anti-clockwise rotation	164231	FLSM-25-L
		Clockwise rotation	164236	FLSM-25-R
	32	Anti-clockwise rotation	164232	FLSM-32-L
		Clockwise rotation	164237	FLSM-32-R
	40	Anti-clockwise rotation	164233	FLSM-40-L
		Clockwise rotation	164238	FLSM-40-R



	For size	Part No.	Type
2 Push-on flange	Dimensions online: → dsm		
	12	14659	FWSR-12
	16	13239	FWSR-16
	25	13240	FWSR-25
	32	13241	FWSR-32
	40	14656	FWSR-40
3 Mounting plate	Dimensions online: → dsm		
	12	165571	HSM-12
	16	165572	HSM-16
	25	165573	HSM-25
	32	165574	HSM-32
	40	165575	HSM-40

1) Viewed towards drive shaft side.

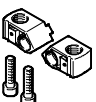
Function	For size	Connection		Part No.	Type	
		Thread	O.D.			
5 One-way flow control valve with slotted head screw, metal²⁾ for exhaust air flow control					Technical data → 609	
	12, 16	M5	3	★	193137	GRLA-M5-QS-3-D
	25		4	★	193138	GRLA-M5-QS-4-D
	32, 40	G $\frac{1}{8}$	6	★	193144	GRLA- $\frac{1}{8}$ -QS-6-D
	63		8	★	193147	GRLA- $\frac{1}{4}$ -QS-8-D
	63		10	★	193148	GRLA- $\frac{1}{4}$ -QS-10-D

2) The recommended flow control valves are based on a tubing length to the valve of 1 m. For deviations of ±50%, flow control valves with a bigger or smaller flow rate must be selected to guarantee the optimum flow control function and cylinder speed.

	For size	Part No.	Type
6 Cushioning mount³⁾			
	12	547900	DSM-12-B
	16	547901	DSM-16-B
	25	547902	DSM-25-B
	32	547903	DSM-32-B
	40	547904	DSM-40-B
	63	552085	DSM-63-B
7 Cushioning kit³⁾, P cushioning			
	12	550657	DSM-12-P-B
	16, 25	550658	DSM-16/25-P-B
	32	550659	DSM-32-P-B
	40	550060	DSM-40-P-B
	63	552086	DSM-63-P-B
8 Shock absorber⁴⁾, P1 cushioning	Technical data online: → dye		
	12	548373	DYEF-M8-Y1F
	16, 25	548374	DYEF-M10-Y1F
	32	548375	DYEF-M12-Y1F
	40	548377	DYEF-M16-Y1F
	63	1113706	DYEF-M22-Y1F

	For size	Part No.	Type	
9 Shock absorber⁴⁾, CC cushioning	Technical data online: → dysc			
	12	548011	DYSC-5-5-Y1F	
	16/25	548012	DYSC-7-5-Y1F	
	32	548013	DYSC-8-8-Y1F	
	40	548014	DYSC-12-12-Y1F	
	63	553593	DYSC-16-18-Y1F	
	10/12/14 Sensor bracket			
	12, 16, 25, 32, 40	★	550661	SL-DSM-B ⁵⁾
	63		552088	SL-DSM-63-B ⁶⁾
	12, 16, 25, 32, 40	★	1130882	SL-DSM-S-M5-B ⁷⁾
		★	1132360	SL-DSM-S-M8-B ⁸⁾

3) Packaging unit 2 pieces.

4) Packaging unit 1 piece.

5) For proximity sensor SME-/SMT-10.

6) For proximity sensor SME-/SMT-8.







7) For inductive proximity sensor SIEN-M5.

8) For inductive proximity sensor SIEN-M8.





Swivel modules DSM-12 ... 63-B

Accessories – Ordering data

1

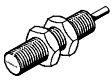
	For size	Part No.	Type	
	PNP, cable	551373	SMT-10M-PS-24V-E-2,5-L-OE	Technical data → 749
	PNP, plug	551375	SMT-10M-PS-24V-E-0,3-L-M8D	
Magnetic reed – N/O contact				Technical data → 745
	Cable	★ 551365	SME-10M-DS-24V-E-2,5-L-OE	Technical data → 747
	Plug	★ 551367	SME-10M-DS-24V-E-0,3-L-M8D	
	Cable	173210	SME-10-KL-LED-24	Technical data → 747
	Plug	173212	SME-10-SL-LED-24	
Proximity sensor for T-slot, for size 63, magneto-resistive – N/O contact				Technical data → 737
	PNP, cable	★ 574335	SMT-8M-A-PS-24V-E-2,5-OE	Technical data → 732
	PNP, plug	★ 574334	SMT-8M-A-PS-24V-E-0,3-M8D	
	PNP, plug	★ 574337	SMT-8M-A-PS-24V-E-0,3-M12	
	NPN, cable	★ 574338	SMT-8M-A-NS-24V-E-2,5-OE	
	NPN, plug	★ 574339	SMT-8M-A-NS-24V-E-0,3-M8D	
	Cable	★ 543862	SME-8M-DS-24V-K-2,5-OE	Technical data → 734
	Cable	★ 543863	SME-8M-DS-24V-K-5,0-OE	
	Cable	★ 543872	SME-8M-ZS-24V-K-2,5-OE	
	Plug	★ 543861	SME-8M-DS-24V-K-0,3-M8D	
	Cable	★ 150855	SME-8-K-LED-24	Technical data → 734
	Plug	150857	SME-8-S-LED-24	

Accessories – Ordering data

	For size		Part No.	Type	
15	Inductive proximity sensor, for size 12 ... 40				Technical data → 755
	M5, cable	★	150370	SIEN-M5B-PS-K-L	
	M5, plug	★	150371	SIEN-M5B-PS-S-L	
	M8, cable	★	150386	SIEN-M8B-PS-K-L	
	M8, plug	★	150387	SIEN-M8B-PS-S-L	
11/13/15	Connecting cable, straight socket				Technical data → 949
	2.5 m	★	541333	NEBU-M8G3-K-2.5-LE3	
	5 m	★	541334	NEBU-M8G3-K-5-LE3	
	Angled socket				Technical data → 949
	2.5 m	★	541338	NEBU-M8W3-K-2.5-LE3	
	5 m	★	541341	NEBU-M8W3-K-5-LE3	
16	Cover cap				Dimensions online: → dsm
	12	★	549194	AKM-12	
	16	★	549195	AKM-16	
	25	★	549196	AKM-25	
	32	★	549197	AKM-32	
	40	★	549198	AKM-40	

Dimensions

Download CAD data → www.festo.com

1

Size	B1 ±0.5	B2	B3	B4	D1 ∅ g7	D2 ∅	D3 ∅ f8	D4
12	19.8	48±0.3	59±0.3	30±0.2	8	15±0.2	24	M3
16	23.5	57±0.3	70±0.3	40±0.2	10	18 _{-0.3}	28	M3
25	28	65±0.3	83±0.3	40±0.2	12	20 _{-0.3}	30	M4
32	35.5	85±0.3	105±0.3	60±0.3	16	27 _{-0.4}	42	M5
40	43.8	105±0.3	130±0.5	80±0.3	20	36 _{-0.4}	52	M6
63	50.3	125±0.5	152 ^{+0.2}	80±0.3	25	40±0.3	70	M10

Size	D5	D6	D7 ∅	D8	D9	D10	EE
12	M4	M2	78±0.3	M8x1	M4	M4	M5
16	M5	M2	91±0.3	M10x1	M5	M5	M5
25	M6	M2	106±0.3	M10x1	M6	M5	M5
32	M8	M2	135±0.3	M12x1	M8	M5	G1/8
40	M10	M2	168±0.5	M16x1	M10	M6	G1/8
63	M10	M3	200±0.5	M22x1.5	M12	M6	G1/4

Size	H1 ±0.2	L1	L2 +0.6 -0.7	L3	L4 ±0.4	L5	L6	L7
12	29.5	68.3±0.3	24.5	20±0.2	3	10.3±0.2/-0.3	55.5±0.8	5±0.1
16	35	82.7±1	28	23±0.2	2.6	13±0.2/-0.4	67.1±0.9	6.5±0.2
25	41.5	97.5±0.5	36.5	30±0.2	4	15.2±0.2/-0.4	81±1	7.5±0.2
32	52.5	127.1±0.5	51	40±0.2	8	19.2±0.2/-0.4	107±1.1	9.5±0.2
40	65	155.5±0.6	62	50±0.3	8	23.7±0.2/-0.4	131±1.2	12±0.2
63	76	197±0.4/-0.55	75.5	60±0.3	10.5	28.5±0.3/-0.5	159.5±1.2	14±0.2

Size	L8	L9	L10	L13	L14 max.	T1 max.	T2 +2	T3 +0.2
12	16.5	3	22.7	6.5	21.2	8.8	9	8
16	20.2	7.2	26.1	6.5	22	11.2	9	8
25	23.5	2.9	20.7	6.5	17	13.5	10	10
32	30.5	3.8	29.1	6.5	23	18	12.5	12
40	36	3.4	43.5	6.5	36.5	22.5	16	15
63	45	10	72.5	4.5	-	28	22	16

Size	⊕ 1	⊕ 2	⊕ 3	⊕ 4	⊕ 5	⊕ 6	Feather key to DIN 6885 ¹⁾
12	10	6	2.5	2.5	2.5	2.5	A2x2x16
16	13	8	3	3	3	5	A3x3x18
25	13	8	4	3	3	6	A4x4x25
32	15	10	5	4	4	8	A5x5x36
40	19	10	6	5	5	10	A6x6x45
63	27	10	8	5	-	-	A8x7x50

1) Included in the scope of delivery.

Note: This product conforms to ISO 1179-1 and ISO 228-1.

Swivel modules DSM-12 ... 63-B

Dimensions

1 DSM- ... -B – With flanged shaft

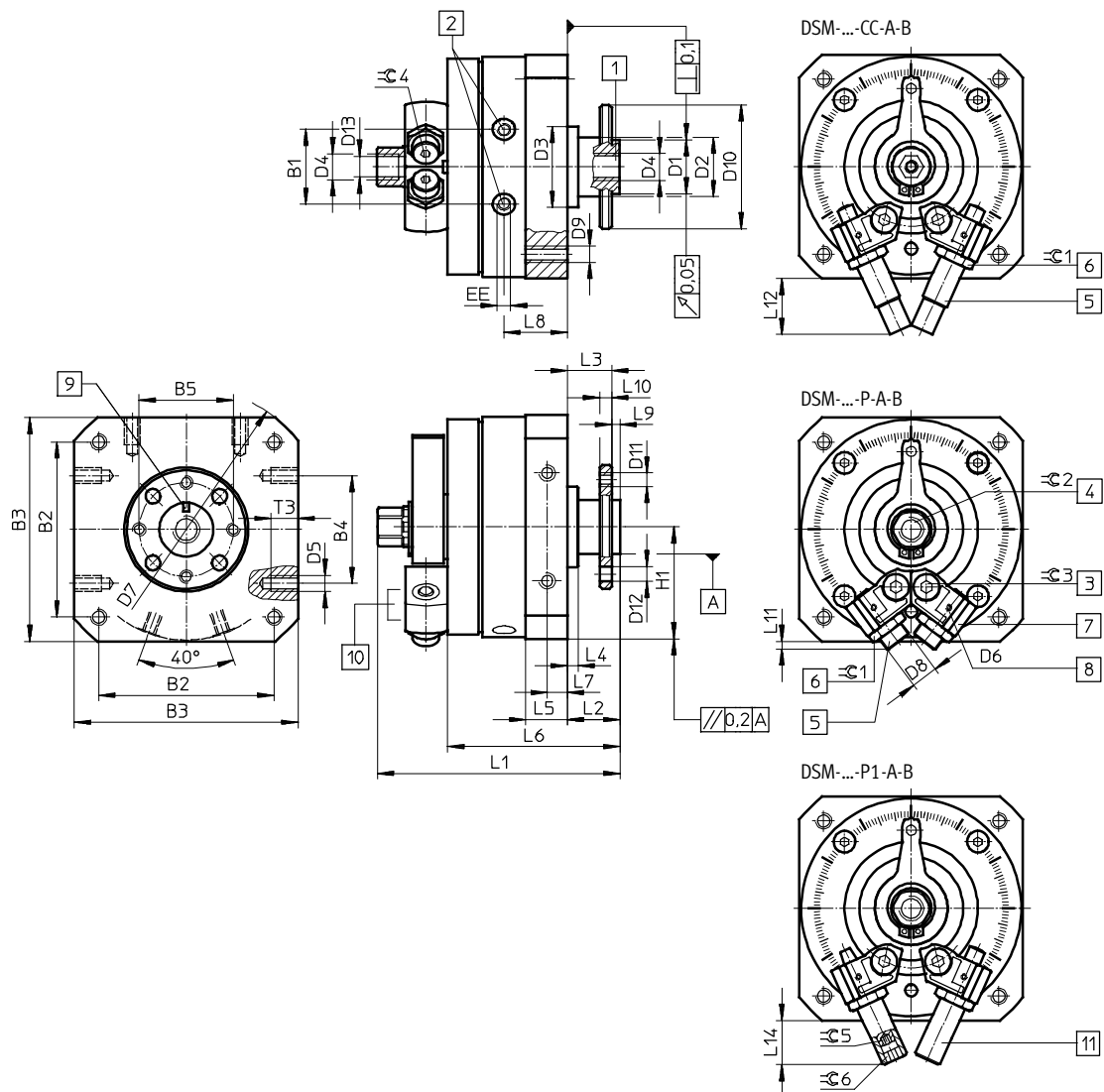

- | | | | |
|---|---|--|--|
| <ul style="list-style-type: none"> 1 Flanged shaft with through-hole 2 Supply ports | <ul style="list-style-type: none"> 3 Locking screw for clamping the stop 4 Manual override (internal hex) | <ul style="list-style-type: none"> 5 End-position adjustment 6 Lock nut for end-position adjustment 7 Infinitely adjustable stops | <ul style="list-style-type: none"> 8 Mounting thread for sensor bracket 9 The position of the marking corresponds to the position of the stop 10 Sensor bracket 11 End-position adjustment |
|---|---|--|--|

Dimensions

Download CAD data → www.festo.com

1

Size	B1 ±0.5	B2	B3	B4	B5	D1 ∅ f8	D2 ∅	D3 ∅ f8	D4	D5
12	19.8	48±0.3	59±0.3	30±0.2	25	14	15±0.2	24	M5	M4
16	23.5	57±0.3	70±0.3	40±0.2	28	16	18 _{-0.3}	28	M5	M5
25	28	65±0.3	83±0.3	40±0.2	35	20	20 _{-0.3}	30	G $\frac{1}{8}$	M6
32	35.5	85±0.3	105±0.3	60±0.3	45	28	27 _{-0.4}	42	G $\frac{1}{8}$	M8
40	43.8	105±0.3	130±0.5	80±0.3	54	36	36 _{-0.4}	52	G $\frac{1}{4}$	M10
63	50.3	125±0.5	152±0.2	80±0.3	64	38	40±0.3	70	G $\frac{1}{4}$	M10

Size	D6	D7 ∅	D8	D9	D10 ∅	D11	D12 H13	D13	EE	H1 ±0.2
12	M2	78±0.3	M8x1	M4	33	M3	3.4	4.2	M5	29.5
16	M2	91±0.3	M10x1	M5	38	M4	4.5	4.2	M5	35
25	M2	106±0.3	M10x1	M6	46	M5	5.5	8.6	M5	41.5
32	M2	135±0.3	M12x1	M8	60	M6	6.5	8.6	G $\frac{1}{8}$	52.5
40	M2	168±0.5	M16x1	M10	70	M8	9	11.5	G $\frac{1}{8}$	65
63	M3	200±0.5	M22x1.5	M12	88	M8	12	11.5	G $\frac{1}{4}$	76

Size	L1	L2 +0.5 -0.85	L3 +0.5 -0.62	L4 ±0.4	L5	L6 ±1	L7	L8	L9 -0.2	L10
12	67.3 _{+0.4/-0.65}	13	11	3	10.3 _{+0.2/-0.3}	44	5±0.1	16.5	2	3±0.1
16	79 _{+0.4/-0.65}	15	13	2.6	13 _{+0.2/-0.4}	54.1	6.5±0.2	20.2	2	4±0.1
25	90 _{+0.4/-0.65}	19.5	16.5	4	15.2 _{+0.2/-0.4}	64	7.5±0.2	23.5	3	4.5±0.1
32	115.8 _{+0.4/-0.65}	27	23	8	19.2 _{+0.2/-0.4}	83	9.5±0.2	30.5	4	6±0.1
40	143.8 _{+0.4/-0.7}	33	28	8	23.7 _{+0.2/-0.4}	102	12±0.2	36	5	7.5±0.1
63	177.4 _{+0.2/-0.55}	37.5	31.5	10.5	28.5 _{+0.3/-0.5}	121.5	14±0.2	45	6	9±0.2

Size	L11	L12	L14 max.	T3 +0.2	∅ 1	∅ 2	∅ 3	∅ 4	∅ 5	∅ 6
12	3	22.7	21.2	8	10	8	2.5	2.5	2.5	2.5
16	7.2	26.1	22	8	13	11	3	3	3	5
25	2.9	20.7	17	10	13	13	4	3	3	6
32	3.8	29.1	23	12	15	13	5	4	4	8
40	3.4	43.5	36.5	15	19	19	6	5	5	10
63	10	72.5	-	16	27	22	8	5	-	-

• Note: This product conforms to ISO 1179-1 and ISO 228-1.

Swivel modules DSM-12 ... 63-B

Dimensions

1 DSM-T- ... -B – With tandem rotary vanes and spigot shaft

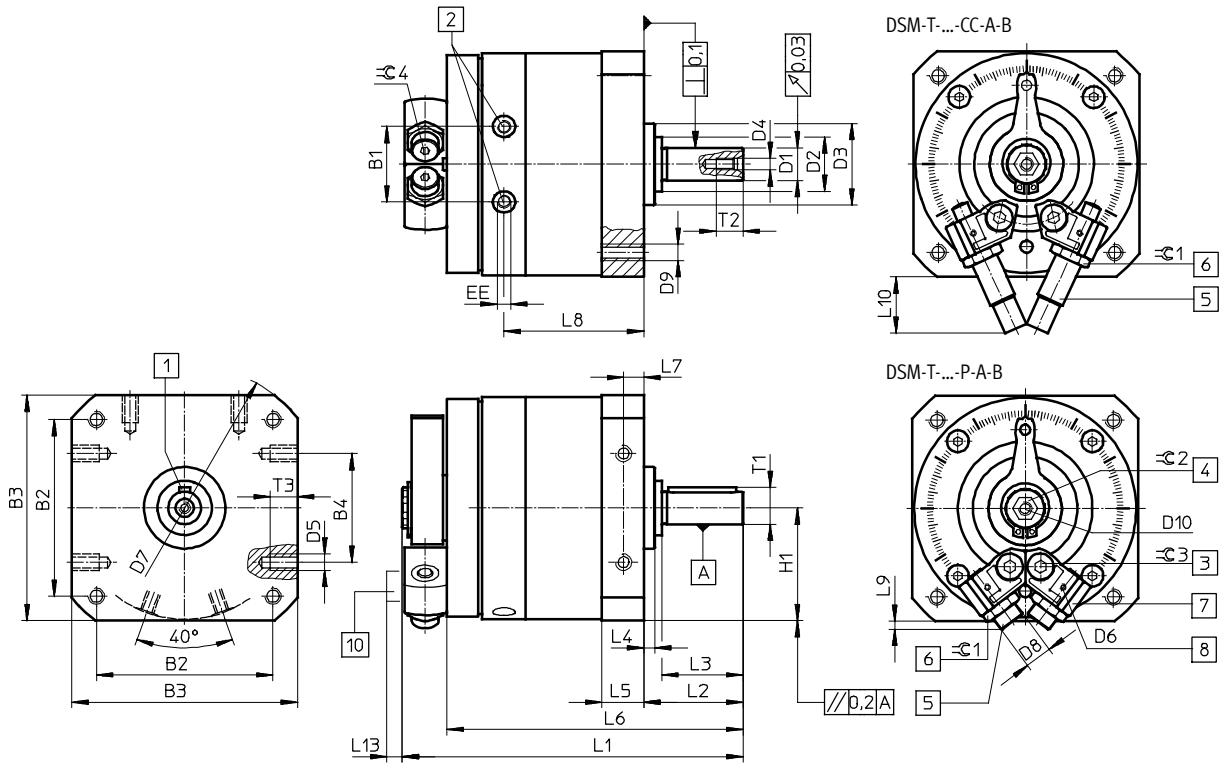

- 1 Feather key position at 0°
- 2 Supply ports

- 3 Locking screw for clamping the stop
- 4 Manual override (internal hex)

- 5 End-position adjustment
- 6 Lock nut for end-position adjustment
- 7 Infinitely adjustable stops

- 8 Mounting thread for sensor bracket
- 10 Sensor bracket

Dimensions

Download CAD data → www.festo.com

1

Size	B1 ±0.5	B2	B3	B4	D1 ∅ g7	D2 ∅	D3 ∅ f8
12	19.8	48±0.3	59±0.3	30±0.2	8	15±0.2	24
16	23.5	57±0.3	70±0.3	40±0.2	10	18 _{-0.3}	28
25	28	65±0.3	83±0.3	40±0.2	12	20 _{-0.3}	30
32	35.5	85±0.3	105±0.3	60±0.3	16	27 _{-0.4}	42
40	43.8	105±0.3	130±0.5	80±0.3	20	36 _{-0.4}	52
63	50.3	125±0.5	152 ^{+0.2}	80±0.3	25	40±0.3	70

Size	D4	D5	D6	D7 ∅	D8	D9	D10
12	M3	M4	M2	78±0.3	M8x1	M4	M4
16	M3	M5	M2	91±0.3	M10x1	M5	M5
25	M4	M6	M2	106±0.3	M10x1	M6	M5
32	M5	M8	M2	135±0.3	M12x1	M8	M5
40	M6	M10	M2	168±0.5	M16x1	M10	M6
63	M10	M10	M3	200±0.5	M22x1.5	M12	M6

Size	EE	H1 ±0.2	L1	L2 +0.6 -0.7	L3	L4 ±0.4	L5
12	M5	29.5	87.3±0.3	24.5	20±0.2	3	10.3 ^{+0.2/-0.3}
16	M5	35	106.6 ⁺¹	28	23±0.2	2.6	13 ^{+0.2/-0.4}
25	M5	41.5	125.5±0.5	36.5	30±0.2	4	15.2 ^{+0.2/-0.4}
32	G ¹ / ₈	52.5	164±0.5	51	40±0.2	8	19.2 ^{+0.2/-0.4}
40	G ¹ / ₈	65	200.5±0.6	62	50±0.3	8	23.7 ^{+0.2/-0.4}
63	G ¹ / ₄	76	254.4 ^{+0.4/-0.55}	75.5	60±0.3	10.5	28.5 ^{+0.3/-0.5}

Size	L6	L7	L8	L9	L10	L13	T1 max.
12	74.5±0.8	5±0.1	35.5	3	22.7	6.5	8.8
16	91±0.9	6.5±0.2	44.1	7.2	26.1	6.5	11.2
25	109±1	7.5±0.2	51.5	2.9	20.7	6.5	13.5
32	144±1.1	9.5±0.2	67.4	3.8	29.1	6.5	18
40	176±1.2	12±0.2	81	3.4	43.5	6.5	22.5
63	216.5±1.2	14±0.2	99	10	72.5	4.5	28

Size	T2 +2	T3 +0.2	≈∅ 1	≈∅ 2	≈∅ 3	≈∅ 4	Feather key to DIN 6885 ¹⁾
12	9	8	10	6	2.5	2.5	A2x2x16
16	9	8	13	8	3	3	A3x3x18
25	10	10	13	8	4	3	A4x4x25
32	12.5	12	15	10	5	4	A5x5x36
40	16	15	19	10	6	5	A6x6x45
63	22	16	27	10	8	5	A8x7x50

1) Included in the scope of delivery.

Note: This product conforms to ISO 1179-1 and ISO 228-1.

Swivel modules DSM-12 ... 63-B

Dimensions

1 DSM-T... -B – With tandem rotary vanes and flanged shaft

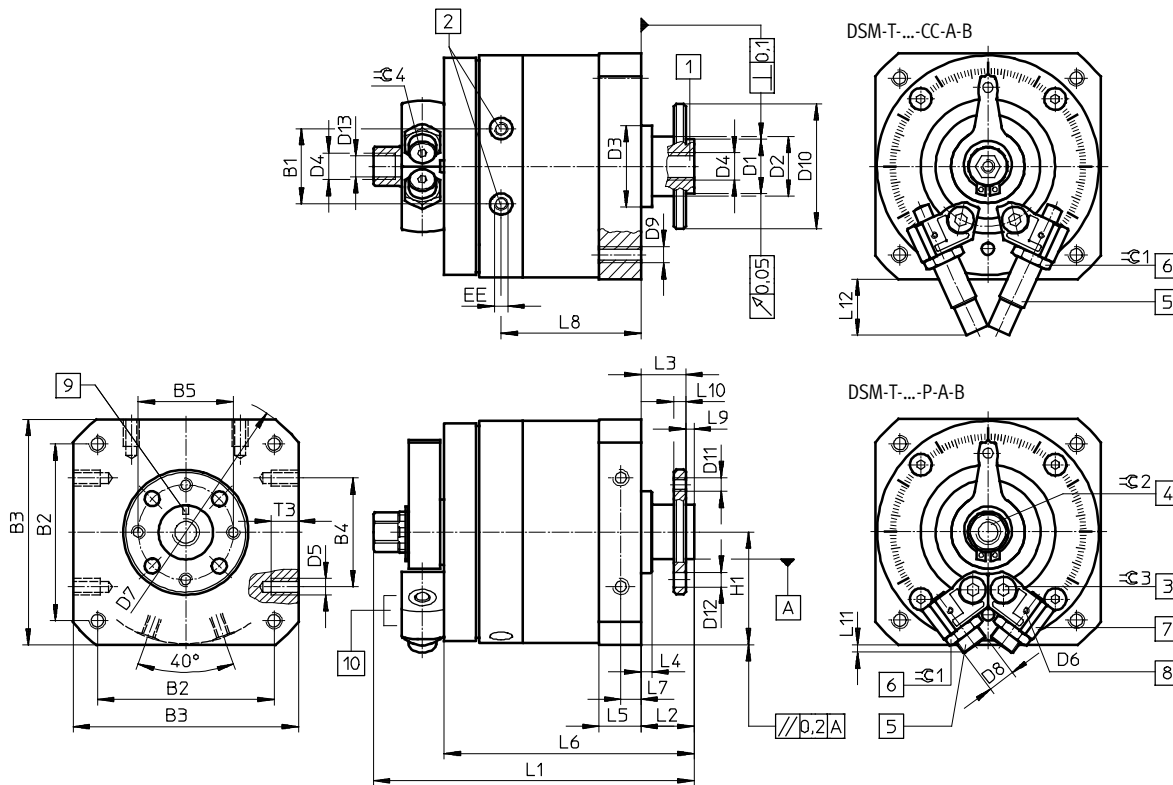

- 1 Flanged shaft with through-hole
- 2 Supply ports

- 3 Locking screw for clamping the stop
- 4 Manual override (internal hex)

- 5 End-position adjustment
- 6 Lock nut for end-position adjustment
- 7 Infinitely adjustable stops

- 8 Mounting thread for sensor bracket
- 9 The position of the marking corresponds to the position of the stop
- 10 Sensor bracket

Dimensions

Download CAD data → www.festo.com

1

Size	B1 ±0.5	B2	B3	B4	B5	D1 ∅ f8	D2 ∅	D3 ∅ f8	D4
12	19.8	48±0.3	59±0.3	30±0.2	25	14	15±0.2	24	M5
16	23.5	57±0.3	70±0.3	40±0.2	28	16	18 _{-0.3}	28	M5
25	28	65±0.3	83±0.3	40±0.2	35	20	20 _{-0.3}	30	G1/8
32	35.5	85±0.3	105±0.3	60±0.3	45	28	27 _{-0.4}	42	G1/8
40	43.8	105±0.3	130±0.5	80±0.3	54	36	36 _{-0.4}	52	G1/4
63	50.3	125±0.5	152±0.2	80±0.3	64	38	40±0.3	70	G1/4

Size	D5	D6	D7 ∅	D8	D9	D10 ∅	D11	D12 H13	D13
12	M4	M2	78±0.3	M8x1	M4	33	M3	3.4	4.2
16	M5	M2	91±0.3	M10x1	M5	38	M4	4.5	4.2
25	M6	M2	106±0.3	M10x1	M6	46	M5	5.5	8.6
32	M8	M2	135±0.3	M12x1	M8	60	M6	6.5	8.6
40	M10	M2	168±0.5	M16x1	M10	70	M8	9	11.5
63	M10	M3	200±0.5	M22x1.5	M12	88	M8	12	11.5

Size	EE	H1 ±0.2	L1	L2 +0.5 -0.85	L3 +0.5 -0.62	L4 ±0.4	L5	L6 ±1	L7
12	M5	29.5	86.3 _{+0.4/-0.65}	13	11	3	10.3 _{+0.2/-0.3}	63	5±0.1
16	M5	35	103 _{+0.4/-0.65}	15	13	2.6	13 _{+0.2/-0.4}	78	6.5±0.2
25	M5	41.5	118 _{+0.4/-0.65}	19.5	16.5	4	15.2 _{+0.2/-0.4}	92	7.5±0.2
32	G1/8	52.5	152.8 _{+0.4/-0.65}	27	23	8	19.2 _{+0.2/-0.4}	120	9.5±0.2
40	G1/8	65	188.8 _{+0.4/-0.7}	33	28	8	23.7 _{+0.2/-0.4}	147	12±0.2
63	G1/4	76	234.4 _{+0.2/-0.55}	37.5	31.5	10.5	28.5 _{+0.3/-0.5}	178.5	14±0.2

Size	L8	L9 -0.2	L10	L11	L12	T3 +0.2	∅ 1	∅ 2	∅ 3	∅ 4
12	35.5	2	3±0.1	3	22.7	8	10	8	2.5	2.5
16	44.1	2	4±0.1	7.2	26.1	8	13	11	3	3
25	51.5	3	4.5±0.1	2.9	20.7	10	13	13	4	3
32	67.4	4	6±0.1	3.8	29.1	12	15	13	5	4
40	81	5	7.5±0.1	3.4	43.5	15	19	19	6	5
63	99	6	9±0.2	10	72.5	16	27	22	8	5

⌋ Note: This product conforms to ISO 1179-1 and ISO 228-1.

Semi-rotary drives DRQD/DRQD-B, twin pistons

1



- Modular structure with a variety of functions
- Sturdy and precise with high torque resistance
- Spare parts service
- Selected types in accordance with the ATEX Directive for explosive atmospheres → www.festo.com/catalogue/ex

→ www.festo.com/catalogue/drqd

Product range overview

Type/function	Piston Ø [mm]	Swivel angle [°]	Torque [Nm]	Product options												→ Page/ online
				B	J20	J60	PPVJ	P1J	YSRJ	A	AL	AR	ZW	FW	Z1	
DRQD																
Double-acting	6, 8, 12	0 ... 180	0.16 ... 0.76	-	■	■	-	-	-	■	-	-	■	■	-	225
	16, 20, 25, 32	0 ... 360	1.7 ... 13.5	■	-	-	■	■	■	■	■	■	■	■	■	228
	40, 50	0 ... 360	25 ... 50	-	-	-	■	-	■	■	■	■	■	■	■	228

Product options

B	Function-optimised design	AR	Supply port on right	SD42	Flanged shaft with energy through-feed, 2 tubes, tubing O.D. 4 mm	E422	2 tubes with 4 mm O.D. and 1x 4-pin cable to 2x 3-pin cables
J20	End-position adjustment, adjustment range +6°/-20°	ZW	Spigot type output shaft	SD48	Flanged shaft with energy through-feed, 8 tubes, tubing O.D. 4 mm	E444	4 tubes with 4 mm O.D. and 2x 4-pin cables to 4x 3-pin cables
J60	End-position adjustment, adjustment range +6°/-60°	FW	Flanged type output shaft	SD62	Flanged shaft with energy through-feed, 2 tubes, tubing O.D. 6 mm	E644	Flanged shaft with energy through-feed, 4 tubes, tubing O.D. 6 mm, 4 electrical cables
PPVJ	Pneumatic cushioning, adjustable at both ends	Z1	1 intermediate position	SD64	Flanged shaft with energy through-feed, 4 tubes, tubing O.D. 6 mm	ZS	Socket head screw
P1J	Elastic cushioning components, adjustable at both ends	A08	Adapter for HGPM-08/HGWM-08			HS	Hollow bolt
YSRJ	Shock absorbers, self-adjusting at both ends	A12	Adapter for HGPM-12/HGWM-12			B1	Mounting type 1
A	Position sensing	AS1	Adapter for DHWS/DHRS-10, DHPS-06			B2	Mounting type 2
AL	Supply port on left	AS2	Adapter for DHDS-16			B3	Mounting type 3
		SD32	Flanged shaft with energy through-feed, 2 tubes, tubing O.D. 3 mm				

Technical data

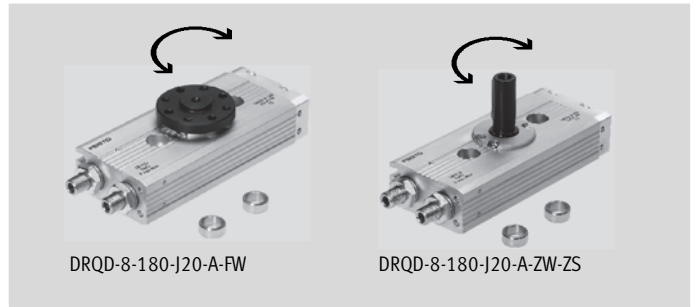

Technical data		Dimensions → 235		
Piston Ø		6	8	12
Pneumatic connection		M3		
Cushioning		Elastic cushioning rings/pads at both ends		
Theoretical torque at 6 bar ¹⁾	[Nm]	0.16	0.33	0.76
Max. perm. swivel frequency at 6 bar	[Hz]			
	90°	5	4	3
	180°	3.5	2.5	2
Adjustable end-position range per end position	[°]			
	J20	-20 ... +6		
	J60	-60 ... +6		
Repetition accuracy	[°]	< 0.2		
Max. perm. mass moment of inertia ²⁾	[kgm ²]	0.075 x 10 ⁻⁴	0.25x 10 ⁻⁴	0.7x 10 ⁻⁴

- 1) If torque acts against the direction of rotation in the end position, a drive with a rating of twice the maximum theoretical torque should be selected.
 2) The data applies to the variants ZW, FW, A... without grippers, unthrottled.

Operating conditions		
Operating pressure	[bar]	1 ... 8
Ambient temperature ³⁾	[°C]	-10 ... +60

- 3) Note operating range of proximity sensors.

Materials	
Drive shaft	Aluminium
Cylinder barrel	Anodised aluminium
Connection cap	Anodised aluminium
Gear rack	Anodised aluminium
Piston	Anodised aluminium
Housing	Aluminium
Pinion	Stainless steel
Seals	NBR, TPE-U (PUR)

Semi-rotary drives DRQD-6 ... 12, twin pistons

1

Order code

DRQD		-		-		-		-	A	-	
Type											
DRQD	Semi-rotary drive										
Piston Ø [mm]											
	Swivel angle [°]										
6, 8, 12	90, 180										
End-position adjustment [°]											
J20	-20 ... +6										
J60	-60 ... +6										
Position sensing											
A	Via proximity sensor										
Output shaft											
ZW	Spigot shaft										
FW	Flanged shaft										

Ordering – Product options

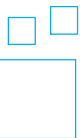

Configurable product

This product and all its options can be ordered using the configurator.

The configurator can be found under Products on the DVD or
 → www.festo.com/catalogue/...

Enter the type code in the search field.

Accessories

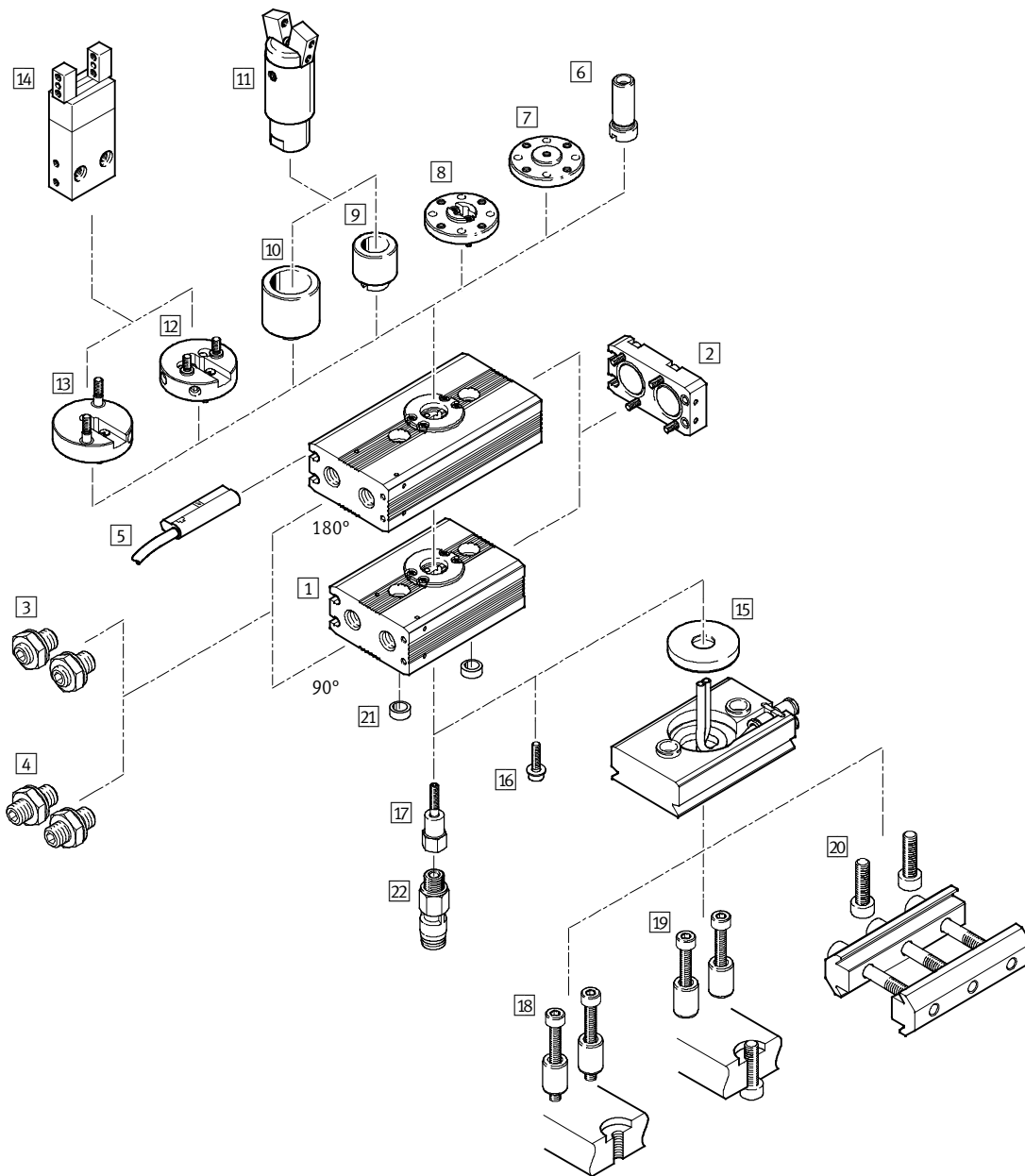

	→ Page/online
1 Centre section	226
2 Connection cap	226
3 End-position adjustment J20	226
4 End-position adjustment J60	226
5 Position sensing A	226
6 Spigot shaft ZW	226
7 Flanged shaft FW	226
8 Flanged shaft FW-SD32	drqd
9 Adapter A08	drqd
10 Adapter A12	drqd
11 Parallel/angle gripper (micro)	gripper
12 Adapter AS1	drqd
13 Adapter AS2	drqd
14 Parallel/angle/radial/three-point gripper	488

	→ Page/online
15 Flanged shaft with energy through-feed SD32	drqd
16 Socket head screw ZS	drqd
17 Hollow bolt HS	drqd
18 Mounting type B1	drqd
19 Mounting type B2	drqd
20 Mounting type B3	drqd
21 Centring sleeve ZBH	233
22 Rotary push-in fitting	233
- Connecting cable NEBU	234
- One-way flow control valve GRLA	234
- Slot cover ABP-5-S	234
- Drive/drive connections	adapter kit
- Drive/gripper connections	adapter kit

Semi-rotary drives DRQD-B-16 ... 32, DRQD-40 ... 50, twin pistons

FESTO

1 Technical data

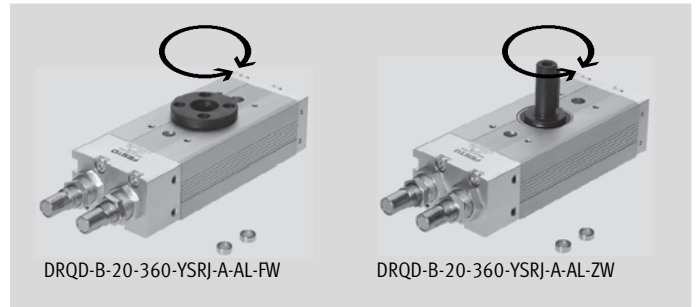

DRQD-B-20-360-YSRJ-A-AL-FW

DRQD-B-20-360-YSRJ-A-AL-ZW

Technical data		Dimensions → 235						
Piston Ø		16	20	25	32	40	50	
Pneumatic connection		M5			G $\frac{1}{8}$		G $\frac{1}{4}$	
Cushioning	PPVJ	Pneumatic cushioning, adjustable at both ends						
	P1J	Elastic cushioning components, adjustable at both ends					–	
	YSRJ	Self-adjusting shock absorbers at both ends						
Theoretical torque at 6 bar ¹⁾	[Nm]							
	PPVJ	1.6	3.1	6.1	12.5	25	50	
	P1J	1.6	3.1	6.1	12.5	–	–	
	YSRJ	1.6	3.1	6.1	12.5	25	50	
Max. perm. swivel frequency at 6 bar	PPVJ	90°	4	3	2	1.2	1.2	1.2
		180°	3	2.2	1.3	0.8	0.9	0.9
		360°	1.5	1.2	0.8	0.5	0.5	0.5
	P1J	90°	3.6	3	2.5	2.2	–	–
		180°	2.5	2.2	1.9	1.6	–	–
		360°	1.5	1.2	1	0.8	–	–
	YSRJ ²⁾	90°	2	2	1.5	1.2	1	0.9
		180°	1.8	1.8	1.5	1.2	1	0.8
		360°	1	1	0.9	0.8	0.7	0.6
	Adjustable end-position range for each end position	[°]						
PPVJ		–20 ... +6						
P1J		–270 ... +6	–320 ... +6	–280 ... +6	–210 ... +6	–	–	
Repetition accuracy (approached from both ends)	[°]	≤ 0.05						
	Z1	≤ 0.15			≤ 0.25	≤ 0.20	≤ 0.30	
Max. perm. mass moment of inertia ³⁾	[kgm ²]							
	PPVJ	5x 10 ^{–4}	10x 10 ^{–4}	20x 10 ^{–4}	40x 10 ^{–4}	200x 10 ^{–4}	500x 10 ^{–4}	
	P1J	→ 229						
YSRJ	→ 230							

1) If torque acts against the direction of rotation in the end position, a drive with a rating of twice the maximum theoretical torque should be selected.

2) At temperatures <0 °C, a max. frequency of 1 Hz applies.

3) The data applies to the variants ZW, FW, A... without grippers, unthrottled.

Operating conditions

Operating pressure	[bar]					
	PPVJ	1 ... 10				
	P1J	3 ... 10				
	YSRJ	2 ... 10				
Ambient temperature ⁴⁾	[°C]					
	Z1	1 ... 10				
		–10 ... +60				

4) Note operating range of proximity sensors.

Semi-rotary drives DRQD-B-16 ... 32, DRQD-40 ... 50, twin pistons

Technical data

Materials	16 ... 32	40 ... 50
Drive shaft	Tempered steel	Tempered steel
Cylinder barrel	Anodised aluminium	Wrought aluminium alloy
Connection cap	Anodised aluminium	Anodised aluminium
Piston	Anodised aluminium	Anodised aluminium
End cap	Aluminium	Anodised wrought aluminium alloy
Housing	Aluminium	Smooth anodised wrought aluminium alloy
Gear rack	High-alloy steel	High-alloy steel
Pinion	Tempered steel	Tempered steel
Seals	NBR, TPE-U (PUR)	NBR, TPE-U (PUR)

Maximum permissible mass moment of inertia J on the drive shaft as a function of swivel time t

DRQD-B-16-...-P1J

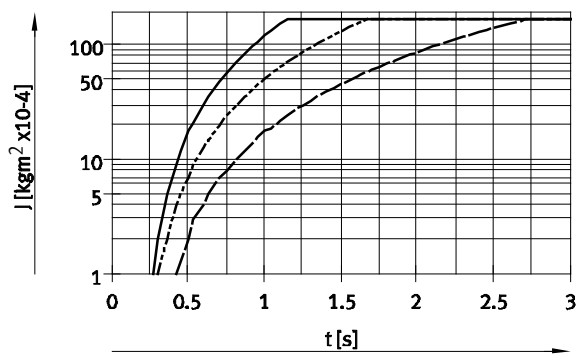

Max. mass moment of inertia = $175 \text{ kgm}^2 \times 10^{-4}$

DRQD-B-20-...-P1J

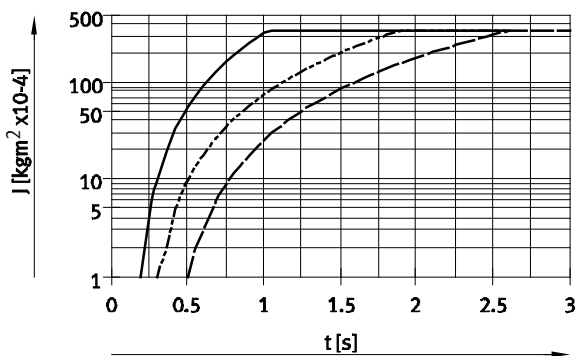

Max. mass moment of inertia = $350 \text{ kgm}^2 \times 10^{-4}$

DRQD-B-25-...-P1J

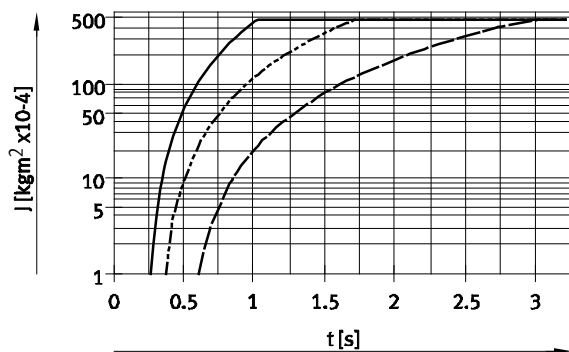

Max. mass moment of inertia = $500 \text{ kgm}^2 \times 10^{-4}$

DRQD-B-32-...-P1J

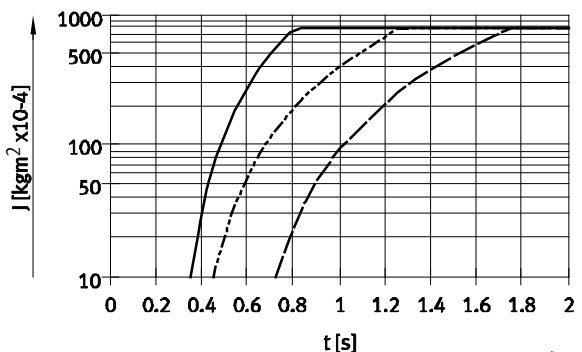

Max. mass moment of inertia = $800 \text{ kgm}^2 \times 10^{-4}$

- 90°
- - - 180°
- · - · 360°

Semi-rotary drives DRQD-B-16 ... 32, DRQD-40 ... 50, twin pistons

Technical data

1

Maximum permissible mass moment of inertia J on the drive shaft as a function of swivel time t

DRQD-B-16-...-YSRJ

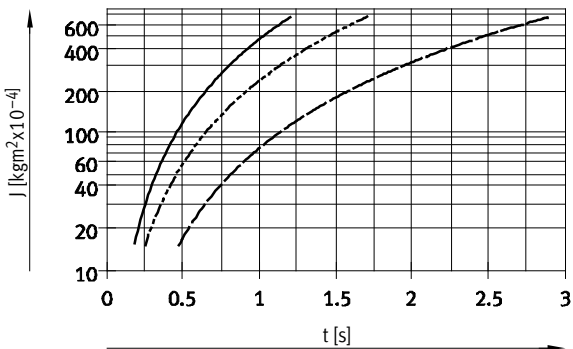

Max. mass moment of inertia = $700 \text{ kgm}^2 \times 10^{-4}$

DRQD-B-20-...-YSRJ

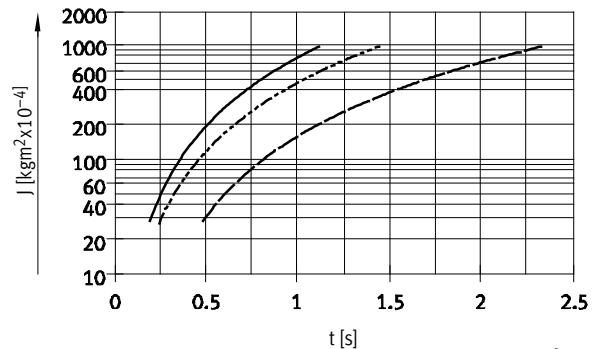

Max. mass moment of inertia = $1,000 \text{ kgm}^2 \times 10^{-4}$

DRQD-B-25-...-YSRJ

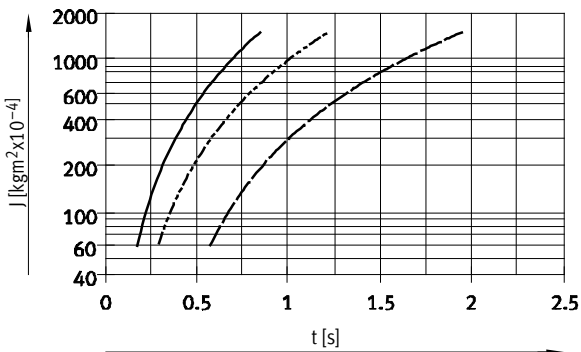

Max. mass moment of inertia = $1,500 \text{ kgm}^2 \times 10^{-4}$

DRQD-B-32-...-YSRJ

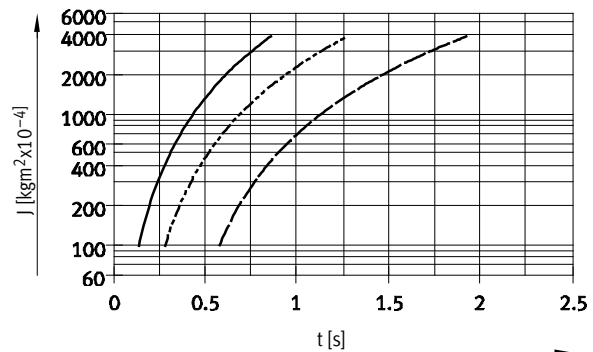

Max. mass moment of inertia = $4,000 \text{ kgm}^2 \times 10^{-4}$

DRQD-40-...-YSRJ

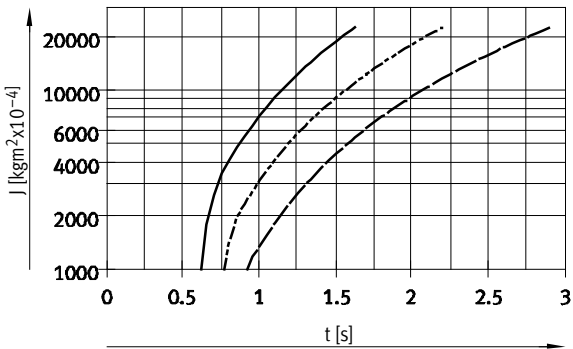

Max. mass moment of inertia = $23,000 \text{ kgm}^2 \times 10^{-4}$

DRQD-50-...-YSRJ

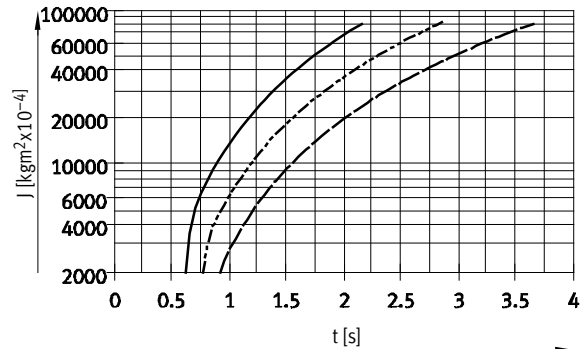

Max. mass moment of inertia = $83,000 \text{ kgm}^2 \times 10^{-4}$

- 90°
- - - 180°
- · — 360°

Order code

DRQD						A		
Type								
DRQD	Semi-rotary drive							
Product version								
B	Function-optimised						1	
Piston Ø [mm]								
		Swivel angle [°]						
16, 20, 25, 32, 40, 50	90, 180, 360		0 ... 340					
Type of cushioning								
PPVJ	Pneumatic cushioning, adjustable at both ends							
P1J	Elastic cushioning components, adjustable at both ends						2	
YSRJ	Self-adjusting shock absorbers at both ends							
Position sensing								
A	Via proximity sensor							
Pneumatic connection								
AL	Supply port on left							
AR	Supply port on right							
Output shaft								
ZW	Spigot shaft							
FW	Flanged shaft							
Intermediate position								
Z1	1 intermediate position (mid-position)							

1 Only with piston Ø 16 ... 32 mm.

2 Only with piston Ø 16 ... 32 mm.

Not with Z1, only with swivel angle 90°, 180°, 360°.

Ordering – Product options

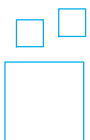

Configurable product

This product and all its options can be ordered using the configurator.

The configurator can be found under Products on the DVD or

→ www.festo.com/catalogue/...

Enter the type code in the search field.

Semi-rotary drives DRQD-B-16 ... 32, DRQD-40 ... 50, twin pistons

Accessories

1

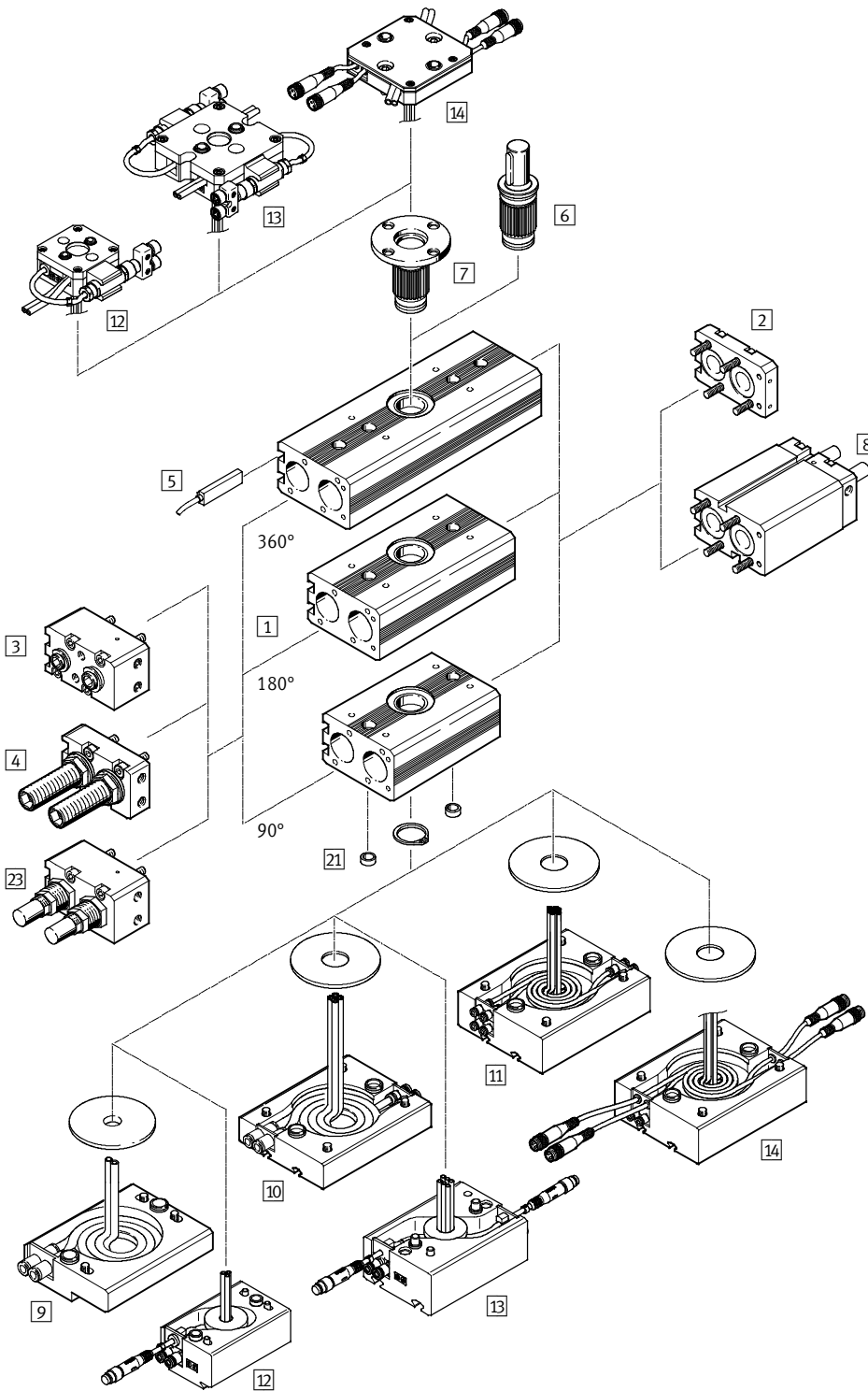

		→ Page/online
1	Centre section	228
2	End cap	228
3	Connection cap PPVJ	228
4	Connection cap YSRJ	228
5	Position sensor A	228
6	Spigot shaft ZW	228
7	Flanged shaft FW	228
8	Intermediate position Z1	231
9	Flanged shaft with energy through-feed SD32, SD42, SD62	drqd
10	Flanged shaft with energy through-feed SD64	drqd
11	Flanged shaft with energy through-feed SD48	drqd

		→ Page/online
12	Flanged shaft with energy through-feed E422	drqd
13	Flanged shaft with energy through-feed E444	drqd
14	Flanged shaft with energy through-feed E644	drqd
21	Centring sleeve ZBH	233
23	Connection cap P1J	228
-	Connecting cable NEBU	234
-	One-way flow control valve GRLA	234
-	Slot cover ABP-5-S	234
-	Drive/drive connections	adapter kit
-	Drive/gripper connections	adapter kit

Accessories – Ordering data

	For Ø		Part No.	Type	
[5] Proximity sensor for T-slot, for Ø 6 ... 12, magneto-resistive – N/O contact Technical data → 737					
	PNP, cable	★	574335	SMT-8M-A-PS-24V-E-2,5-OE	
	PNP, plug	★	574334	SMT-8M-A-PS-24V-E-0,3-M8D	
	PNP, plug	★	574337	SMT-8M-A-PS-24V-E-0,3-M12	
	NPN, cable	★	574338	SMT-8M-A-NS-24V-E-2,5-OE	
	NPN, plug	★	574339	SMT-8M-A-NS-24V-E-0,3-M8D	
Magneto-resistive – N/C contact Technical data → 737					
	PNP, cable	★	574340	SMT-8M-A-PO-24V-E-7,5-OE	
Magnetic reed – N/O contact Technical data → 732					
	Cable	★	543862	SME-8M-DS-24V-K-2,5-OE	
	Cable	★	543863	SME-8M-DS-24V-K-5,0-OE	
	Cable	★	543872	SME-8M-ZS-24V-K-2,5-OE	
	Plug	★	543861	SME-8M-DS-24V-K-0,3-M8D	
Technical data → 734					
	Cable	★	150855	SME-8-K-LED-24	
	Plug		150857	SME-8-S-LED-24	
Magnetic reed – N/C contact Technical data → 734					
	Cable		160251	SME-8-O-K-LED-24	
[5] Proximity sensor for C-slot, for Ø 16 ... 50, magneto-resistive – N/O contact Technical data → 749					
	PNP, cable	★	551373	SMT-10M-PS-24V-E-2,5-L-OE	
	PNP, plug	★	551375	SMT-10M-PS-24V-E-0,3-L-M8D	
Magnetic reed – N/O contact Technical data → 745					
	Plug	★	551367	SME-10M-DS-24V-E-0,3-L-M8D	
	Cable	★	551365	SME-10M-DS-24V-E-2,5-L-OE	
	Cable	★	551369	SME-10M-ZS-24V-E-2,5-L-OE	
Technical data → 747					
	Plug		173212	SME-10-SL-LED-24	
	Cable		173210	SME-10-KL-LED-24	

	For Ø	Description	Part No.	Type	
[21] Centring sleeve¹⁾ Technical data online: → zbh					
	6	For centring the drive on attachments	186717	ZBH-7	
	8 ... 32		150927	ZBH-9	
	40, 50		191409	ZBH-15	
	16, 20	For centring attachments on the flanged shaft FW	186717	ZBH-7	
	25, 32		150927	ZBH-9	
	40, 50		191409	ZBH-12	

1) Packaging unit 10 pieces.





	For Ø	Description	Part No.	Type	
[22] Rotary push-in fitting²⁾					
	6 ... 12	Straight	153526	QSR-M5-4	
		L-shape	153529	QSRL-M5-4	

2) In combination with hollow bolt HS.

Semi-rotary drives DRQD/DRQD-B, twin pistons

Accessories – Ordering data

1

	For Ø		Part No.	Type	
Connecting cable, straight socket					Technical data → 949
	2.5 m	★	541333	NEBU-M8G3-K-2.5-LE3	
	5 m	★	541334	NEBU-M8G3-K-5-LE3	
	2.5 m		541363	NEBU-M12G5-K-2.5-LE3	
	5 m		541364	NEBU-M12G5-K-5-LE3	
Angled socket					Technical data → 949
	2.5 m	★	541338	NEBU-M8W3-K-2.5-LE3	
	5 m	★	541341	NEBU-M8W3-K-5-LE3	
	2.5 m		541367	NEBU-M12W5-K-2.5-LE3	
	5 m		541370	NEBU-M12W5-K-5-LE3	

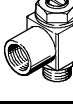
Function	For Ø	Connection		Part No.	Type
		Thread	O.D.		
One-way flow control valve with slotted head screw, metal¹⁾ for exhaust air flow control					
	6, 8, 12	M3	3	175041	GRLA-M3-QS-3
	16	M5	3	★ 193137	GRLA-M5-QS-3-D
	20, 25		6	★ 193139	GRLA-M5-QS-6-D
	32, 40	G $\frac{1}{8}$	–	151165	GRLA- $\frac{1}{8}$ -B
	50	G $\frac{1}{4}$	–	151172	GRLA- $\frac{1}{4}$ -B

1) The recommended flow control valves are based on a tubing length to the valve of 1 m. For deviations of ±50%, flow control valves with a bigger or smaller flow rate must be selected to guarantee the optimum flow control function and cylinder speed.

	For Ø	Part No.	Type
Slot cover²⁾			
	16 ... 50	151680	ABP-5-S

2) Packaging unit 2x 0.5 m.

Semi-rotary drives DRQD-6 ... 12, twin pistons

Dimensions

1 FW – With flanged shaft

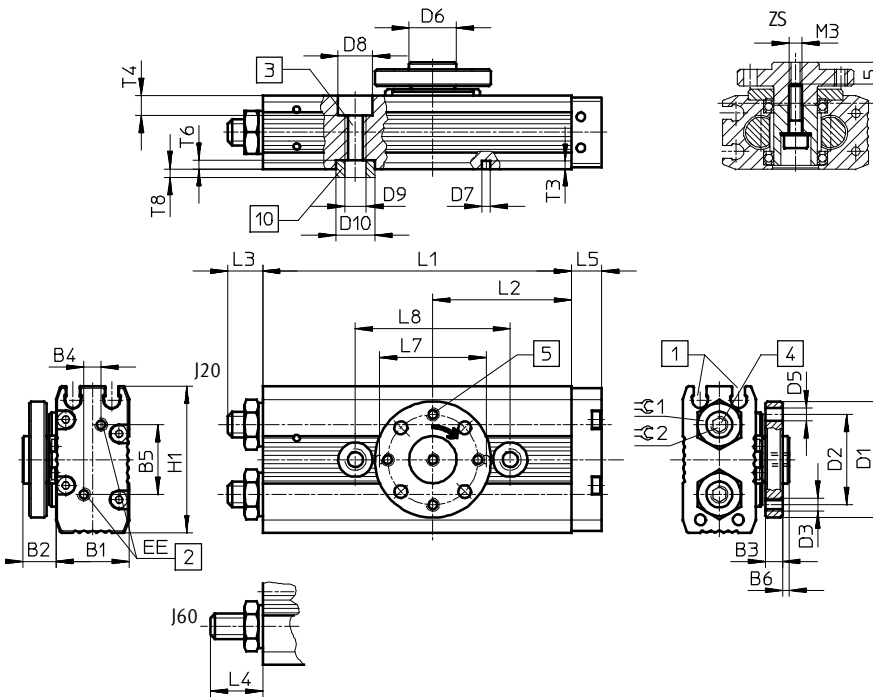

- | | | |
|---|---|--|
| <p>1 Slots for proximity sensor
SME-/SMT-10</p> <p>2 Supply ports</p> | <p>3 Mounting thread</p> <p>4 Socket head screw for
end-position adjustment</p> | <p>5 Position of designated thread
hole at 0°</p> <p>10 Centring sleeves (2 included in
the scope of delivery)</p> |
|---|---|--|

Dimensions

Download CAD data → www.festo.com

1

∅ [mm]	Swivel angle [°]	B1	B2	B3	B4	B5	B6	D1 ∅	D2 ∅	D3	D5 ∅ H7
6	90	15.4	7.7	4	2	13.6	1.5	23	16	M3	3
	180										
8	90	17	7.7	4	4	16.2	1.5	27	21	M3	3
	180										
12	90	21	7.7	4	6	18.2	1.5	27	21	M3	3
	180										

∅ [mm]	Swivel angle [°]	D6 ∅ g7	D7 ∅ H8	D8 ∅ H8	D9	D10 ∅ H7	EE	H1	L1	L2	L3 max.
6	90	8	2	6	M4	7	M3	31	46.7	20.20	7.1
	180								61.8	27.75	
8	90	11	-	8	M5	9	M3	34	54.2	23.45	8.1
	180								71.8	32.25	
12	90	11	-	8	M5	9	M3	41	59.2	25.95	9.1
	180								76.8	34.75	

∅ [mm]	Swivel angle [°]	L4 max.	L5	L7 ±0.03	L8 ±0.03	T3	T4	T6	T8	≈C1	≈C2
6	90	11.1	7.5	20	30	1.8	3.4	1.6	1.4	8	2.5
	180										
8	90	12.1	7	-	36	-	4.6	2	2	10	3
	180										
12	90	13.1	8	-	36	-	4.6	2	2	13	4
	180										

Semi-rotary drives DRQD-B-16 ... 32, twin pistons

Dimensions

1 ZW – With spigot shaft

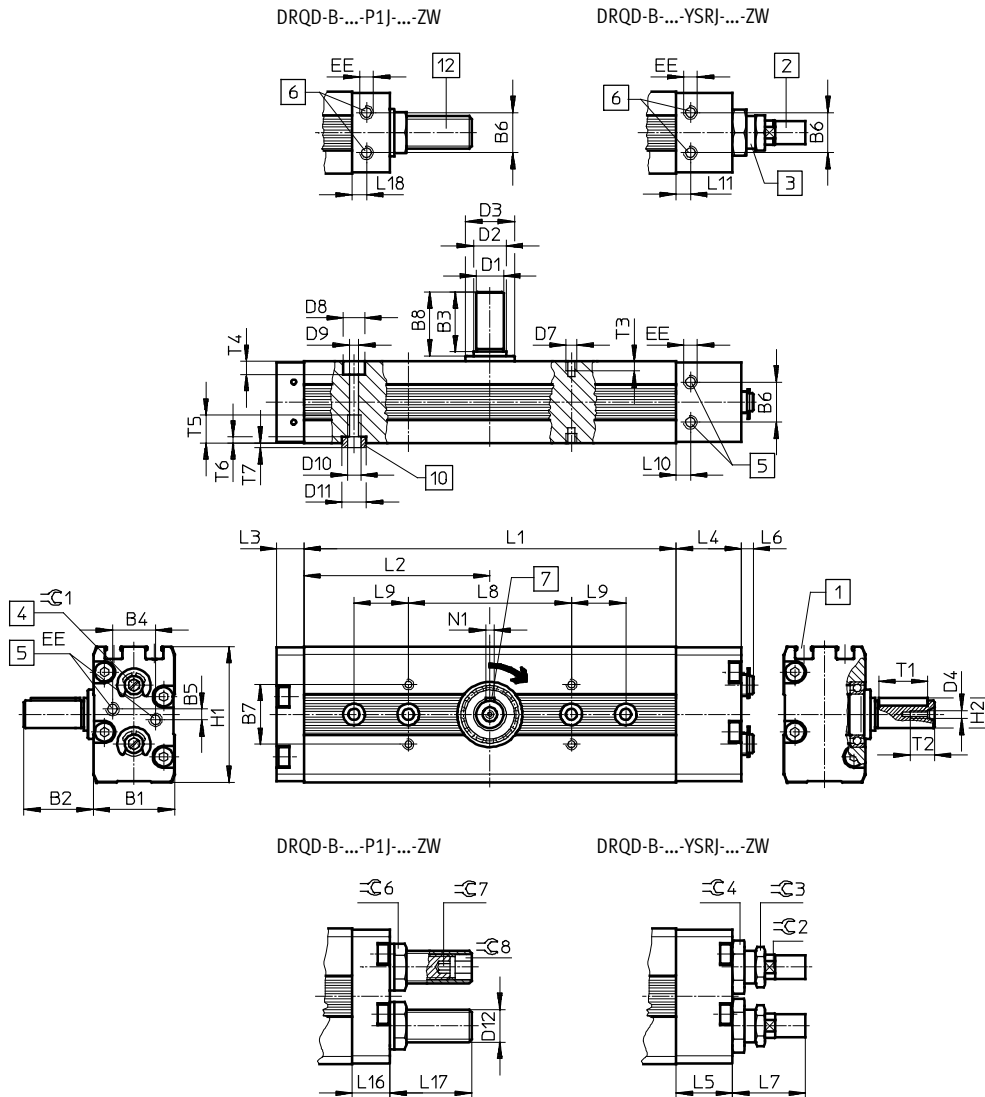

- 1 Slots for proximity sensor SME/SMT-8
- 2 Self-adjusting shock absorber for end-position cushioning
- 3 Adjustment sleeve for end-position adjustment with DRQD-B-...-YSRJ
- 4 Socket head screw for end-position adjustment with integrated regulating screw for end-position cushioning
- 5 Variant PPVJ: both supply ports on one end cap, optionally on front or side
- 6 Variant YSRJ: both supply ports on one end cap, on side only
- 7 Feather key position at 0°
- 10 Centring sleeves (2 included in the scope of delivery)
- 12 Adjustable cushioning component for end-position cushioning

Semi-rotary drives DRQD-B-16 ... 32, twin pistons

FESTO

Dimensions

Download CAD data → www.festo.com

1

∅ [mm]	Swivel angle [°]	B1	B2	B3	B4	B5	B6	B7	B8	D1 ∅ g6	D2 ∅	D3 ∅	D4	D7	D8 ∅ H13	D9 ∅	D10	D11 ∅ H7	D12
16	90	30	25.5	23	17.8	4	14.8	22	23.5	10	12	18	M3	M4	8	4.2	M5	9	M12
	180																		
	360																		
20	90	36	32.5	30	21.8	4	19.8	26	30.5	12	15	24	M4	M4	8	4.2	M5	9	M14
	180																		
	360																		
25	90	42	42.5	40	24.8	4	24.8	30	40.5	16	20	30	M5	M5	10	5.3	M6	9	M16
	180																		
	360																		
32	90	51	52.5	50	29.8	2	29.8	36	50.5	20	25	35	M6	M5	10	5.3	M6	9	M22
	180																		
	360																		

∅ [mm]	Swivel angle [°]	EE	H1	H2	L1	L2	L3	L4	L5	L6		L7		L8 ±0.03	L9 ±0.03	L10	L11	L16
										min.	max.	min.	max.					
16	90	M5	50	11.2	71	35.5	10	24	20.8	1.7	5.7	23.4	28.2	60	-	7.6	5.3	14
	180				93	46.5									-			
	360				137	68.5									20			
20	90	M5	56	13.5	78.4	39.2	10	31.5	27	2.4	7	28.6	35.9	60	-	8	5	13.5
	180				104.8	52.4									-			
	360				157.6	78.8									20			
25	90	M5	67	18	91.2	45.6	11	36.5	33	2.6	8.9	42	50.2	60	-	11	5	15
	180				124	62									-			
	360				189.2	94.6									20			
32	90	G $\frac{1}{8}$	79	22.5	114.8	57.4	13	39	39	4.3	11.8	59.4	70.1	80	-	13.1	8	20
	180				155.6	77.8									20			
	360				237.4	118.7									20			

∅ [mm]	Swivel angle [°]	L17		L18	N1 P9	T1	T2	T3	T4	T5	T6	T7	≈C1	≈C2	≈C3	≈C4	≈C6	≈C7	≈C8
		min.	max.																
16	90	6.7	41	5.8	3	18.1	9	3.5	5	10	2	2	4	9	13	17	15	4	8
	180																		
	360																		
20	90	8.5	59.5	5	4	25.1	10	3.5	5	12	2	2	7	11	15	19	17	4	8
	180																		
	360																		
25	90	9	61.4	5	5	36.1	12.5	5	6	12	2	2	7	15	19	24	19	5	10
	180																		
	360																		
32	90	10	60	8	6	45.1	16	5	6	14	2	2	8	20	27	32	27	5	10
	180																		
	360																		

Semi-rotary drives DRQD-40 ... 50, twin pistons

Dimensions

1 ZW – With spigot shaft

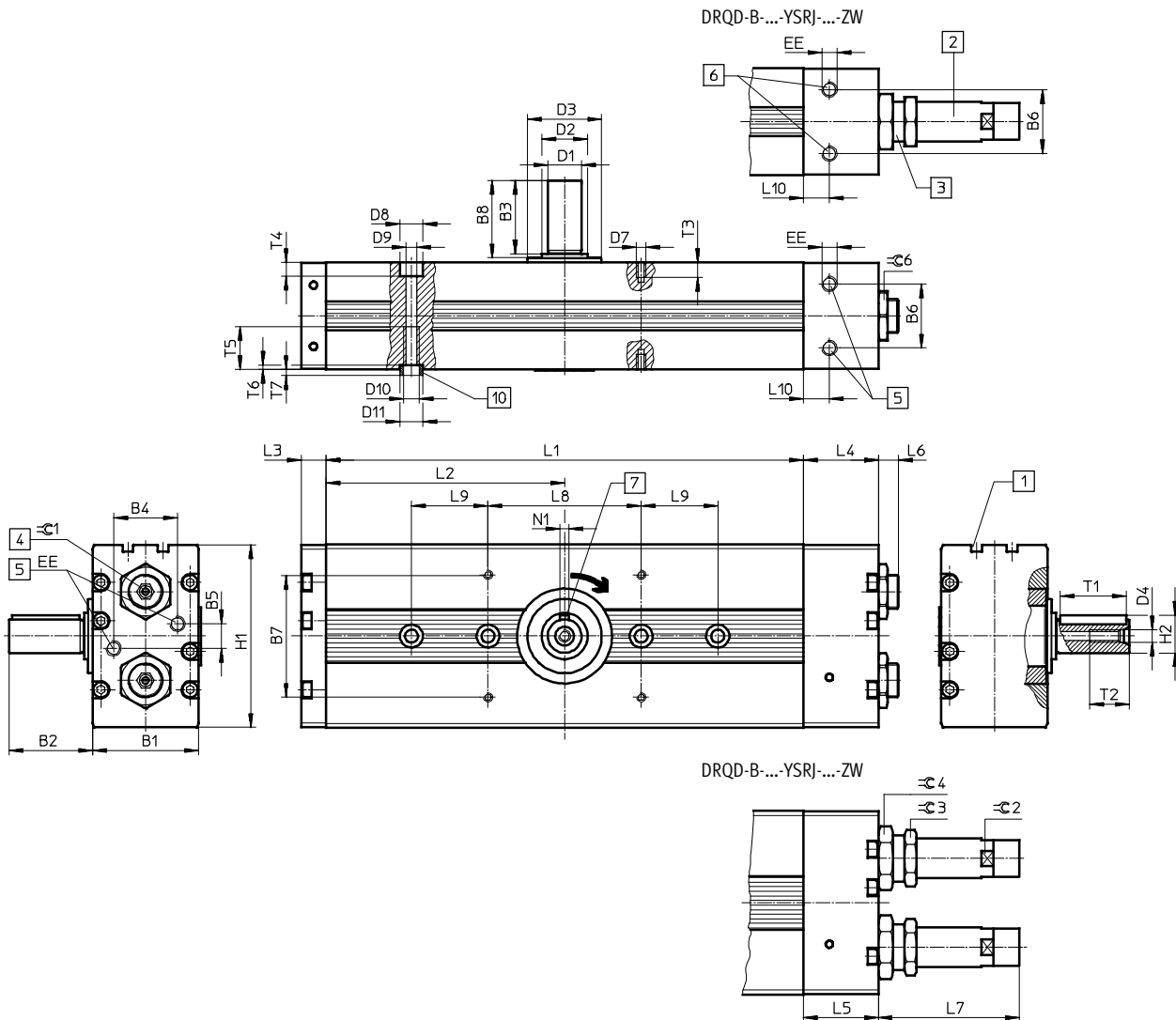

- | | | | |
|---|---|--|--|
| <p>1 Slots for proximity sensor SME-/SMT-8</p> <p>2 Self-adjusting shock absorber for end-position cushioning</p> | <p>3 Adjustment sleeve for end-position adjustment with DRQD-...-YSRJ</p> <p>4 Socket head screw for end-position adjustment with integrated regulating screw for end-position cushioning</p> | <p>5 Variant PPVJ: both supply ports on one end cap, optionally on front or side</p> <p>6 Variant YSRJ: both supply ports on one end cap, on side only</p> | <p>7 Feather key position at 0°</p> <p>10 Centring sleeves (2 included in the scope of delivery)</p> |
|---|---|--|--|

Dimensions

Download CAD data → www.festo.com

1

∅ [mm]	Swivel angle [°]	B1	B2	B3	B4	B5	B6	B7	B8	D1 ∅ g6	D2 ∅	D3 ∅	D4	D7	D8 ∅ H13	D9 ∅
40	90	70	53.5	50	42	4	42	80	50.5	22	30	48.5	M8	M6	15	8.5
	180															
	360															
50	90	86	63.5	60	50	16	50	80	60.9	28	38	58.5	M12	M6	15	8.5
	180															
	360															

∅ [mm]	Swivel angle [°]	D10	D11 ∅ H7	EE	H1	H2	L1	L2	L3	L4	L5	L6		L7		L8 ±0.03
												min.	max.	min.	max.	
40	90	M10	15	G1/8	120	24.5	146.8	73.4	16	49	41.5	5	14.6	85.1	96.4	100
	180						201.8	100.9								
	360						311.8	155.9								
50	90	M10	15	G1/4	144	31	191.4	95.7	18	64	55	8	20.7	107.8	120.6	100
	180						262.8	131.4								
	360						405.8	202.9								

∅ [mm]	Swivel angle [°]	L9 ±0.03	L10	N1 P9	T1	T2 +2	T3	T4	T5	T6	T7	≈C1	≈C2	≈C3	≈C4	≈C6
40	90	–	17	6	45.1	26	10	10	28	3	3	10	24	32	36	27
	180	–														
	360	50														
50	90	–	21.2	8	56.1	28	10	11	28	3	3	14	28	36	46	41
	180	50														
	360	100														

Semi-rotary drives DRQD-B-16 ... 32, twin pistons

Dimensions

1 FW – With flanged shaft

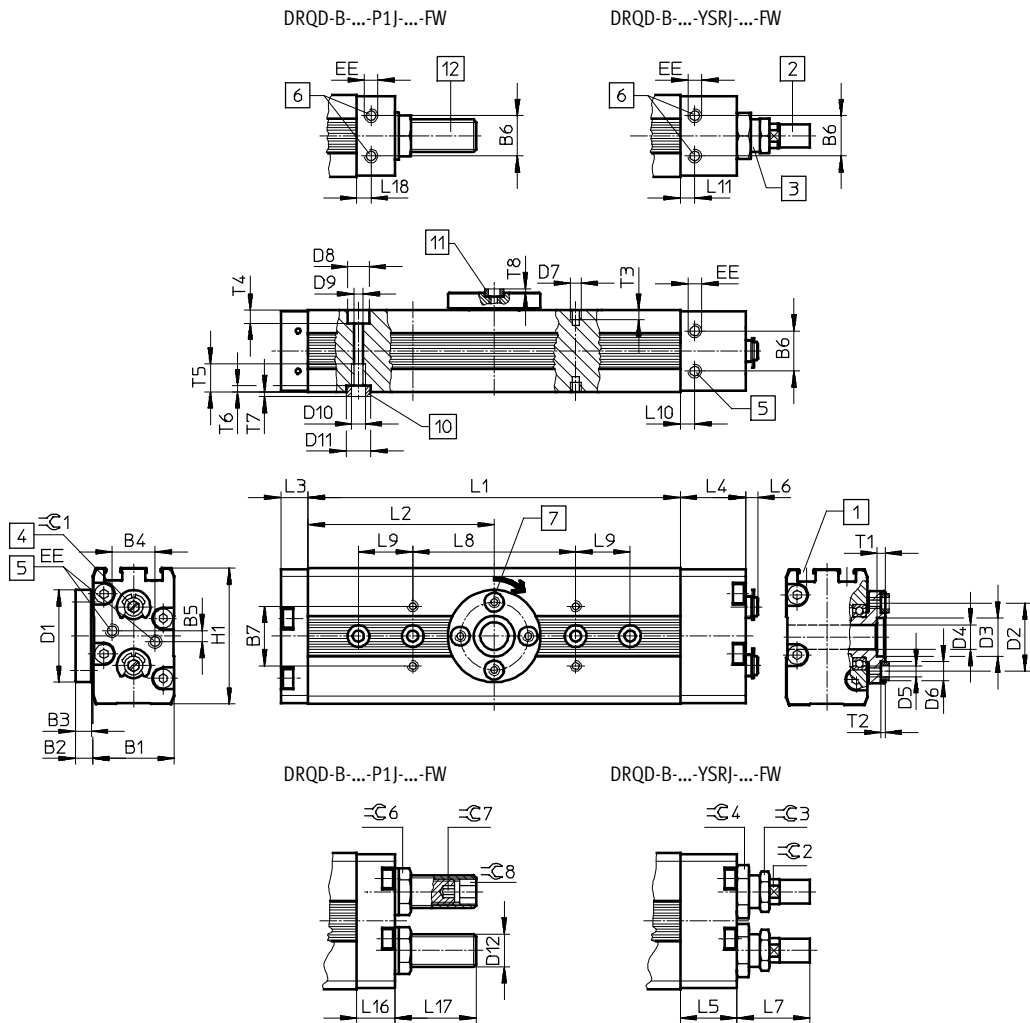

- 1 Slots for proximity sensor SME/SMT-8
- 2 Self-adjusting shock absorber for end-position cushioning
- 3 Adjustment sleeve for end-position adjustment with DRQD-B-...-YSRJ
- 4 Socket head screw for end-position adjustment with integrated regulating screw for end-position cushioning
- 5 Variant PPVJ: both supply ports on one end cap, optionally on front or side
- 6 Variant YSRJ: both supply ports on one end cap, on side only
- 7 Position of centring hole at 0°
- 10 Centring sleeves (2 included in the scope of delivery)
- 11 Centring sleeves (not included in the scope of delivery)
- 12 Adjustable cushioning component for end-position cushioning

Semi-rotary drives DRQD-B-16 ... 32, twin pistons

FESTO

Dimensions

Download CAD data → www.festo.com

1

∅ [mm]	Swivel angle [°]	B1	B2	B3	B4	B5	B6	B7	D1 ∅	D2 ∅ ±0.025	D3 ∅ H8	D4 ∅	D5	D6 ∅ H7	D7	D8 ∅ H13	D9 ∅	D10	D11 ∅ H7
16	90	30	6.5	6	17.8	4	14.8	22	34	25	14	9	M4	7	M4	8	4.2	M5	9
	180																		
	360																		
20	90	36	6.5	6	21.8	4	19.8	26	38	28	16	11	M4	7	M4	8	4.2	M5	9
	180																		
	360																		
25	90	42	9.5	9	24.8	4	24.8	30	48	34	16	12	M6	9	M5	10	5.3	M6	9
	180																		
	360																		
32	90	51	9.5	9	29.8	2	29.8	36	58	45	19	14	M6	9	M5	10	5.3	M6	9
	180																		
	360																		

∅ [mm]	Swivel angle [°]	D12	EE	H1	L1	L2	L3	L4	L5	L6		L7		L8	L9	L10	L11	L16
										min.	max.	min.	max.					
16	90	M12	M5	50	71	35.5	10	24	20.8	1.7	5.7	23.4	28.2	60	-	7.6	5.3	14
	180				93	46.5									-			
	360				137	68.5									20			
20	90	M14	M5	56	78.4	39.2	10	31.5	27	2.4	7	28.6	35.9	60	-	8	5	13.5
	180				104.8	52.4									-			
	360				157.6	78.8									20			
25	90	M16	M5	67	91.2	45.6	11	36.5	33	2.6	8.9	42	50.2	60	-	11	5	15
	180				124	62									-			
	360				189.2	94.6									20			
32	90	M22	G1/8	79	114.8	57.4	13	39	39	4.3	11.8	59.4	70.1	80	-	13.1	8	20
	180				155.6	77.8									20			
	360				237.4	118.7									20			

∅ [mm]	Swivel angle [°]	L17		L18	T1	T2	T3	T4	T5	T6	T7	T8	≈C1	≈C2	≈C3	≈C4	≈C6	≈C7	≈C8
		min.	max.																
16	90	6.7	41	5.8	3	1.6	3.5	5	10	2	2	1.4	4	9	13	17	15	4	8
	180																		
	360																		
20	90	8.5	59.5	5	3	1.6	3.5	5	12	2	2	1.4	7	11	15	19	17	4	8
	180																		
	360																		
25	90	9	61.4	5	3	2	5	6	12	2	2	2	7	15	19	24	19	5	10
	180																		
	360																		
32	90	10	60	8	3	2	5	6	14	2	2	2	8	20	27	32	27	5	10
	180																		
	360																		

Semi-rotary drives DRQD-40 ... 50, twin pistons

Dimensions

1 FW – With flanged shaft

DRQD-...-YSRJ-...-FW

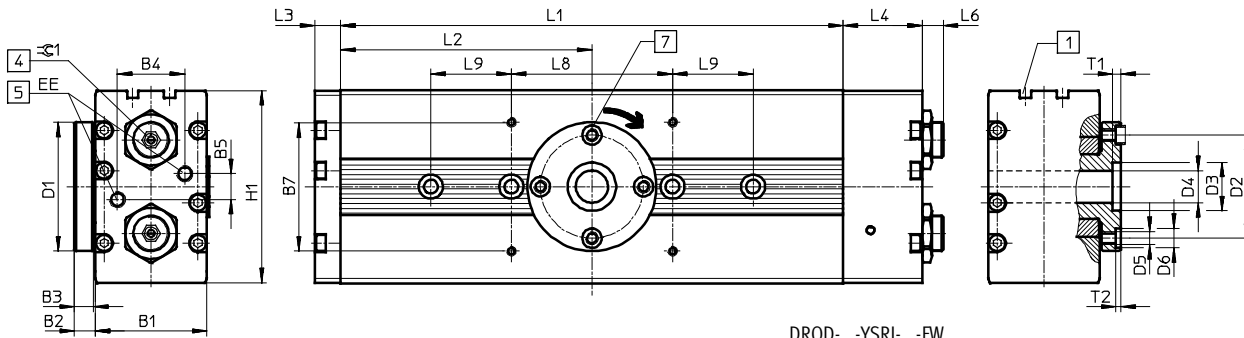
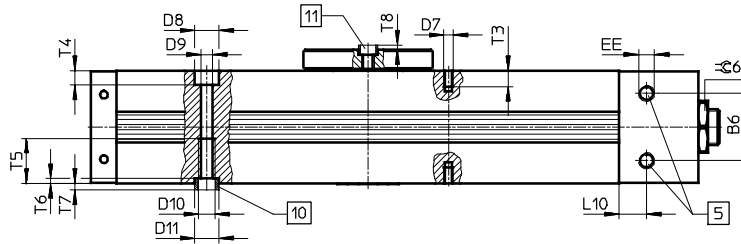
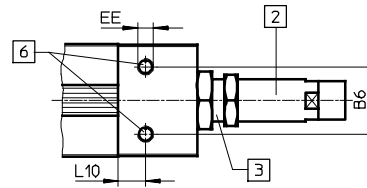

DRQD-...-YSRJ-...-FW

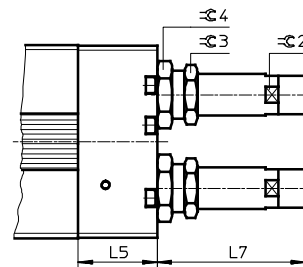

- | | | | |
|---|---|--|---|
| <p>1 Slots for proximity sensor SME-/SMT-8</p> <p>2 Self-adjusting shock absorber for end-position cushioning</p> | <p>3 Adjustment sleeve for end-position adjustment with DRQD-...-YSRJ</p> <p>4 Socket head screw for end-position adjustment with integrated regulating screw for end-position cushioning</p> | <p>5 Variant PPVJ: both supply ports on one end cap, optionally on front or side</p> <p>6 Variant YSRJ: both supply ports on one end cap, on side only</p> | <p>7 Feather key position at 0°</p> <p>10 Centring sleeves (2 included in the scope of delivery)</p> <p>11 Centring sleeves (not included in the scope of delivery)</p> |
|---|---|--|---|

Dimensions

Download CAD data → www.festo.com

1

∅ [mm]	Swivel angle [°]	B1	B2	B3	B4	B5	B6	B7	D1 ∅	D2 ∅ ±0.025	D3 ∅ H7	D4	D5	D6 ∅ H7	D7	D8 ∅ H13
40	90	70	13	12	42	4	42	80	80	64	30	20	M8	12	M6	15
	180															
	360															
50	90	86	13	12	50	16	50	80	85	64	30	24	M8	12	M6	15
	180															
	360															

∅ [mm]	Swivel angle [°]	D9 ∅	D10	D11 ∅ H7	EE	H1	L1		L2	L3	L4	L5	L6		L7	
							min.	max.					min.	max.		
40	90	8.5	M10	15	G $\frac{1}{8}$	120	146.8	73.4	16	49	41.5	5	14.6	85.1	96.4	
	180						201.8	100.9								
	360						311.8	155.9								
50	90	8.5	M10	15	G $\frac{1}{4}$	144	191.4	95.7	18	64	55	8	20.7	107.8	120.6	
	180						262.8	131.4								
	360						405.8	202.9								

∅ [mm]	Swivel angle [°]	L8 ±0.03	L9 ±0.03	L10	T1	T2	T3	T4	T5	T6	T7	≈C1	≈C2	≈C3	≈C4	≈C6
40	90	100	–	17	4	2.7	10	10	28	3	3	10	24	32	36	27
	180		–													
	360		50													
50	90	100	–	21.2	4	2.7	10	11	28	3	3	14	28	36	46	41
	180		50													
	360		100													

Semi-rotary drives DRQD-B-16 ... 32, twin pistons

Dimensions

1 Z1 – With intermediate position

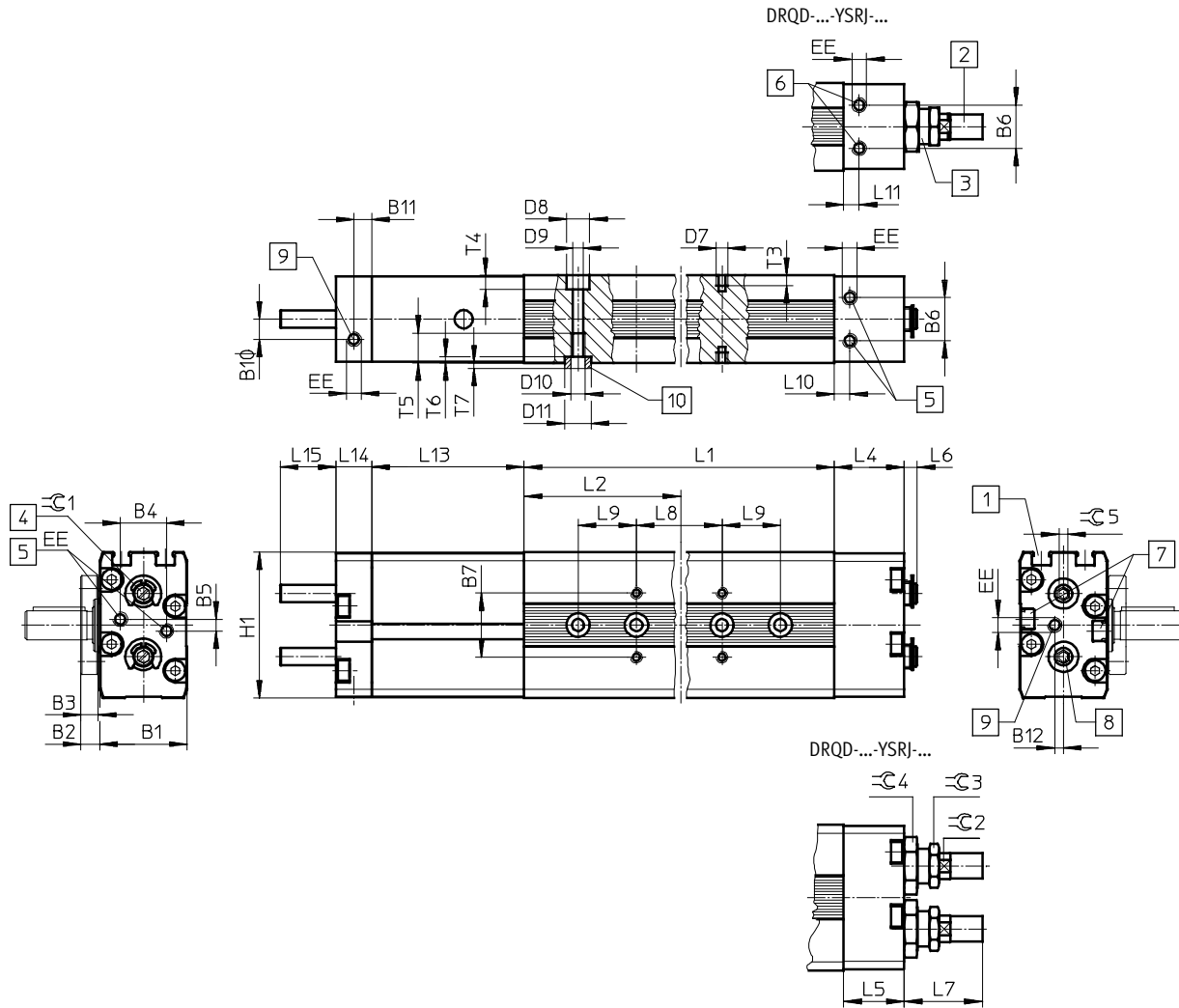

- | | | | |
|--|--|---|---|
| <p>1 Slots for proximity sensor SME-/SMT-8 for end-position sensing</p> <p>2 Self-adjusting shock absorber for end-position cushioning</p> <p>3 Adjustment sleeve for end-position adjustment with DRQD-...-YSRJ</p> | <p>4 Socket head screw for end-position adjustment with integrated regulating screw for end-position cushioning</p> <p>5 Variant PPVJ: both supply ports on one end cap, optionally on front or side</p> | <p>6 Variant YSRJ: both supply ports on one end cap, on side only</p> <p>7 Slots for proximity sensor SME-/SMT-8 for end-position sensing</p> <p>8 Socket head screw for intermediate-position adjustment (slightly recessed)</p> | <p>9 Supply port for intermediate position on end cap, optionally on side or front</p> <p>10 Centring sleeves (2 included in the scope of delivery)</p> |
|--|--|---|---|

Semi-rotary drives DRQD-B-16 ... 32, twin pistons

FESTO

Dimensions

Download CAD data → www.festo.com

1

∅ [mm]	Swivel angle [°]	B1	B2	B3	B4	B5	B6	B7	B10	B11	B12	D7	D8 ∅ H13	D9 ∅	D10	D11 ∅ H7
16	90	30	6.5	6	17.8	4	14.8	22	6.4	4.5	3	M4	8	4.2	M5	9
	180															
20	90	36	6.5	6	21.8	4	19.8	26	6.5	4.5	5.6	M4	8	4.2	M5	9
	180															
25	90	42	9.5	9	24.8	4	24.8	30	9.1	6.9	8.2	M5	10	5.3	M6	9
	180															
32	90	51	9.5	9	29.8	2	29.8	36	9	8	9	M5	10	5.3	M6	9
	180															

∅ [mm]	Swivel angle [°]	EE	H1	L1	L2	L4	L5	L6		L7		L8 ±0.03	L9 ±0.03	L10	L11
								min.	max.	min.	max.				
16	90	M5	50	71	35.5	24	20.8	1.7	5.7	23.4	28.2	60	-	7.6	5.3
	180			93	46.5								-		
20	90	M5	56	78.4	39.2	31.5	27	2.4	7	28.6	35.9	60	-	8	5
	180			104.8	52.4								-		
25	90	M5	67	91.2	45.6	36.5	33	2.6	8.9	42	50.2	60	-	11	5
	180			124	62								-		
32	90	G $\frac{1}{8}$	79	114.8	57.4	39	39	4.3	11.8	59.4	70.1	80	-	13.1	8
	180			155.6	77.8								20		

∅ [mm]	Swivel angle [°]	L13	L14	L15		T3	T4	T5	T6	T7	≈C1	≈C2	≈C3	≈C4	≈C5
				min.	max.										
16	90	52.2	12.3	0	19.1	3.5	5	10	2	2	4	9	13	17	3
	180														
20	90	55.4	12.3	0	21.8	3.5	5	12	2	2	7	11	15	19	3
	180														
25	90	62.1	15	0	26	5	6	12	2	2	7	15	19	24	4
	180														
32	90	68.2	15.5	0	31.5	5	6	14	2	2	8	20	27	32	4
	180														

Semi-rotary drives DRQD-40 ... 50, twin pistons

Dimensions

1 Z1 – With intermediate position

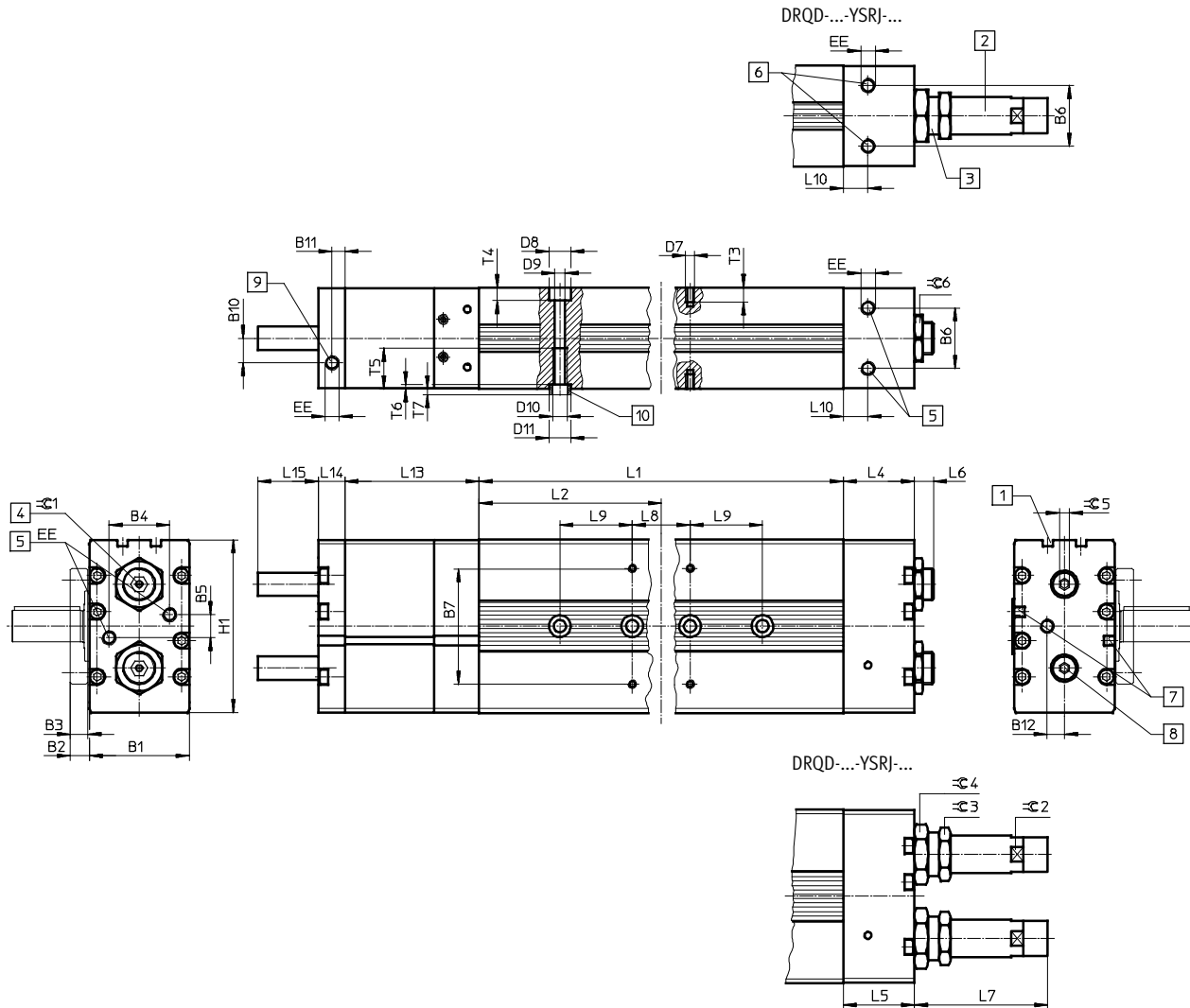

- | | | | |
|--|--|---|---|
| <p>1 Slots for proximity sensor SME-/SMT-8 for end-position sensing</p> <p>2 Self-adjusting shock absorber for end-position cushioning</p> <p>3 Adjustment sleeve for end-position adjustment with DRQD-...-YSRJ</p> | <p>4 Socket head screw for end-position adjustment with integrated regulating screw for end-position cushioning</p> <p>5 Variant PPVJ: both supply ports on one end cap, optionally on front or side</p> | <p>6 Variant YSRJ: both supply ports on one end cap, on side only</p> <p>7 Slots for proximity sensor SME-/SMT-8 for end-position sensing</p> <p>8 Socket head screw for intermediate-position adjustment (slightly recessed)</p> | <p>9 Supply port for intermediate position on end cap, optionally on side or front</p> <p>10 Centring sleeves (2 included in the scope of delivery)</p> |
|--|--|---|---|

Semi-rotary drives DRQD-40 ... 50, twin pistons

FESTO

Dimensions

Download CAD data → www.festo.com

1

∅ [mm]	Swivel angle [°]	B1	B2	B3	B4	B5	B6	B7	B10	B11	B12	D7	D8 ∅ H13	D9 ∅	D10
40	90	70	13	12	42	4	42	80	92.5	9	12	M6	15	8.5	M10
	180														
	360														
50	90	86	13	12	50	16	50	80	105.7	9	14	M6	15	8.5	M10
	180														
	360														

∅ [mm]	Swivel angle [°]	D11 ∅ H7	EE	H1	L1		L2	L4	L5	L6		L7		L8 ±0.03	L9 ±0.03	L10
					min.	max.				min.	max.					
40	90	15	G $\frac{1}{8}$	120	146.8	73.4	49	41.5	5	14.6	85.1	96.4	100	-	17	
	180				201.8	100.9								-		
	360				311.8	155.9								50		
50	90	15	G $\frac{1}{4}$	144	191.4	95.7	64	55	8	20.7	107.8	120.6	100	-	21.2	
	180				262.8	131.4								50		
	360				405.8	202.9								100		

∅ [mm]	Swivel angle [°]	L13	L14	L15		T3	T4	T5	T6	T7	≈C1	≈C2	≈C3	≈C4	≈C5	≈C6
				min.	max.											
40	90	92.5	18.5	0	41.95	10	10	28	3	3	10	24	32	36	7	27
	180															
	360															
50	90	105.7	20.5	0	52.95	10	11	28	3	3	14	28	36	46	7	41
	180															
	360															

Mini slides DGSL

1



- High load capacity and positioning accuracy
- Maximum flexibility thanks to 8 sizes
- Guide unit with very precise linearity and parallelism
- Simple basic setting plus precision final adjustment of the end positions
- ★ Quick ordering of basic designs → 253

→ www.festo.com/catalogue/dgsl

Product range overview

Type/function	Size	Stroke [mm]	Force [N]	Product options								
				C	E3	P	P1	Y3	E	Y11	N	A
DGSL												
Double-acting	4, 6, 8, 10, 12, 16, 20, 25	10 ... 200	17 ... 483	■	■	■	■	■	■	■	■	■

Product options

N	NPT thread	P	Elastic cushioning without metal end position, adjustable	Y3	Progressive shock absorber, at both ends	Y11	Progressive shock absorber with reducing sleeve, at both ends
C	Clamping unit	P1	Elastic cushioning with metal end position, adjustable	E	Elastic cushioning without metal end position, adjustable, short design	N	No cushioning
E3	End-position locking					A	Position sensing

Technical data

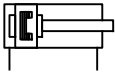

1

Technical data		Dimensions → 258							
Size		4	6	8	10	12	16	20	25
Pneumatic connection		M3			M5			G1/8	
Cushioning	P	Elastic cushioning without metal end position, adjustable							
	E	Elastic cushioning without metal end position, adjustable, short design							
	P1	Elastic cushioning with metal end position, adjustable							
	Y3	–			Progressive shock absorber, at both ends				
	Y11	–			Progressive shock absorber with reducing sleeve, at both ends				
	N	–			No cushioning				
Theoretical force at 6 bar, advancing	[N]	17	30	47	68	121	188	295	483
Theoretical force at 6 bar, retracting	[N]	13	23	40	51	104	158	247	415

Technical data – Clamping unit		Dimensions → 258						
Size		6	8	10	12	16	20	25
Clamping type with effective direction		At both ends						
		Clamping via spring force, air to release						
Static holding force	[N]	80	80	180	180	350	350	600

Technical data – End-position locking		Dimensions → 258						
Size		6	8	10	12	16	20	25
Clamping type with effective direction		At both ends						
		Clamping via spring force, air to unlock						
Static holding force	[N]	60	60	160	160	250	380	640

Operating conditions		Dimensions → 258							
Size		4	6	8	10	12	16	20	25
Min. operating pressure	[bar]	2.5	1.5				1		
Max. operating pressure	[bar]	8							
Ambient temperature ¹⁾	[°]	0 ... +60							

1) Note operating range of proximity sensors.

Materials	
Housing	Wrought aluminium alloy
End cap	Wrought aluminium alloy
Guide rail	Tempered steel
Piston rod	High-alloy stainless steel
Seals	HNBR

Mini slides DGSL

1

Order code

Type		DGSL	-		-		-		-		-		A
DGSL	Mini slide												
Size													
	Stroke [mm]												
4	10, 20, 30												
6	10, 20, 30, 40, 50												
8	10, 20, 30, 40, 50, 80												
10	10, 20, 30, 40, 50, 80, 100												
12	10, 20, 30, 40, 50, 80, 100, 150												
16	10, 20, 30, 40, 50, 80, 100, 150												
20	10, 20, 30, 40, 50, 80, 100, 150, 200												
25	10, 20, 30, 40, 50, 80, 100, 150, 200												
Clamping unit													
C	Attached											1	
End-position locking													
E3	With piston rod in retracted position											1/2	
Cushioning													
P	Elastic cushioning without metal end position, adjustable												
P1	Elastic cushioning with metal end position, adjustable												
Y3	Progressive shock absorber, at both ends											3	
E	Elastic cushioning without metal end position, adjustable, short design												
Y11	Progressive shock absorber with reducing sleeve, at both ends											4	
N	No cushioning											3	
Position sensing													
A	Via proximity sensor												

- 1 Not with size 4.
- 2 Not with clamping unit C.
- 3 Not with size 4 and 6, minimum stroke 30 mm.
- 4 Not with size 4 ... 8, minimum stroke 30 mm.

Note
Operation without cushioning components is not permitted.

Ordering – Product options

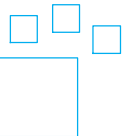

Configurable product

This product and all its options can be ordered using the configurator.

The configurator can be found under Products on the DVD or
[→ www.festo.com/catalogue/...](http://www.festo.com/catalogue/...)

Enter the type code in the search field.

★ Quick ordering

PA – Elastic cushioning without metal end position, adjustable

Part No.	Type
Piston Ø 12 mm	
543961	DGSL-12-10-PA
543962	DGSL-12-20-PA
543963	DGSL-12-30-PA
543964	DGSL-12-40-PA
543965	DGSL-12-50-PA
543966	DGSL-12-80-PA
543967	DGSL-12-100-PA
543968	DGSL-12-150-PA
Piston Ø 16 mm	
543983	DGSL-16-10-PA
543984	DGSL-16-20-PA
543985	DGSL-16-30-PA
543986	DGSL-16-40-PA
543987	DGSL-16-50-PA
543988	DGSL-16-80-PA
543989	DGSL-16-100-PA
543990	DGSL-16-150-PA

Part No.	Type
Piston Ø 20 mm	
544005	DGSL-20-10-PA
544006	DGSL-20-20-PA
544007	DGSL-20-30-PA
544008	DGSL-20-40-PA
544009	DGSL-20-50-PA
544010	DGSL-20-80-PA
544011	DGSL-20-100-PA
544012	DGSL-20-150-PA
544013	DGSL-20-200-PA

Part No.	Type
Piston Ø 25 mm	
544030	DGSL-25-10-PA
544031	DGSL-25-20-PA
544032	DGSL-25-30-PA
544033	DGSL-25-40-PA
544034	DGSL-25-50-PA
544035	DGSL-25-80-PA
544036	DGSL-25-100-PA
544037	DGSL-25-150-PA
544038	DGSL-25-200-PA

EA – Elastic cushioning without metal end position, adjustable, short design

Part No.	Type
Piston Ø 12 mm	
570179	DGSL-12-10-EA
570180	DGSL-12-20-EA
570181	DGSL-12-30-EA
570182	DGSL-12-40-EA
570183	DGSL-12-50-EA
570184	DGSL-12-80-EA
570185	DGSL-12-100-EA
570186	DGSL-12-150-EA
Piston Ø 16 mm	
570187	DGSL-16-10-EA
570188	DGSL-16-20-EA
570189	DGSL-16-30-EA
570190	DGSL-16-40-EA
570191	DGSL-16-50-EA
570192	DGSL-16-80-EA
570193	DGSL-16-100-EA
570194	DGSL-16-150-EA

Part No.	Type
Piston Ø 20 mm	
570195	DGSL-20-10-EA
570196	DGSL-20-20-EA
570197	DGSL-20-30-EA
570198	DGSL-20-40-EA
570199	DGSL-20-50-EA
570200	DGSL-20-80-EA
570201	DGSL-20-100-EA
570202	DGSL-20-150-EA
570203	DGSL-20-200-EA

Part No.	Type
Piston Ø 25 mm	
570204	DGSL-25-10-EA
570205	DGSL-25-20-EA
570206	DGSL-25-30-EA
570207	DGSL-25-40-EA
570208	DGSL-25-50-EA
570209	DGSL-25-80-EA
570210	DGSL-25-100-EA
570211	DGSL-25-150-EA
570212	DGSL-25-200-EA

★ Quick ordering

1

P1A – Elastic cushioning with metal end position, adjustable

Part No.	Type
Piston Ø 12 mm	
543969	DGSL-12-10-P1A
543970	DGSL-12-20-P1A
543971	DGSL-12-30-P1A
543972	DGSL-12-40-P1A
543973	DGSL-12-50-P1A
543974	DGSL-12-80-P1A
543975	DGSL-12-100-P1A
543976	DGSL-12-150-P1A
Piston Ø 16 mm	
543991	DGSL-16-10-P1A
543992	DGSL-16-20-P1A
543993	DGSL-16-30-P1A
543994	DGSL-16-40-P1A
543995	DGSL-16-50-P1A
543996	DGSL-16-80-P1A
543997	DGSL-16-100-P1A
543998	DGSL-16-150-P1A

Part No.	Type
Piston Ø 20 mm	
544014	DGSL-20-10-P1A
544015	DGSL-20-20-P1A
544016	DGSL-20-30-P1A
544017	DGSL-20-40-P1A
544018	DGSL-20-50-P1A
544019	DGSL-20-80-P1A
544020	DGSL-20-100-P1A
544021	DGSL-20-150-P1A
544022	DGSL-20-200-P1A

Part No.	Type
Piston Ø 25 mm	
544039	DGSL-25-10-P1A
544040	DGSL-25-20-P1A
544041	DGSL-25-30-P1A
544042	DGSL-25-40-P1A
544043	DGSL-25-50-P1A
544044	DGSL-25-80-P1A
544045	DGSL-25-100-P1A
544046	DGSL-25-150-P1A
544047	DGSL-25-200-P1A

Y3A – Progressive shock absorber, at both ends

Part No.	Type
Piston Ø 12 mm	
543977	DGSL-12-30-Y3A
543978	DGSL-12-40-Y3A
543979	DGSL-12-50-Y3A
543980	DGSL-12-80-Y3A
543981	DGSL-12-100-Y3A
543982	DGSL-12-150-Y3A
Piston Ø 16 mm	
543999	DGSL-16-30-Y3A
544000	DGSL-16-40-Y3A
544001	DGSL-16-50-Y3A
544002	DGSL-16-80-Y3A
544003	DGSL-16-100-Y3A
544004	DGSL-16-150-Y3A

Part No.	Type
Piston Ø 20 mm	
544023	DGSL-20-30-Y3A
544024	DGSL-20-40-Y3A
544025	DGSL-20-50-Y3A
544026	DGSL-20-80-Y3A
544027	DGSL-20-100-Y3A
544028	DGSL-20-150-Y3A
544029	DGSL-20-200-Y3A

Part No.	Type
Piston Ø 25 mm	
544048	DGSL-25-30-Y3A
544049	DGSL-25-40-Y3A
544050	DGSL-25-50-Y3A
544051	DGSL-25-80-Y3A
544052	DGSL-25-100-Y3A
544053	DGSL-25-150-Y3A
544054	DGSL-25-200-Y3A

Accessories

1

Note
End stops must not be removed.

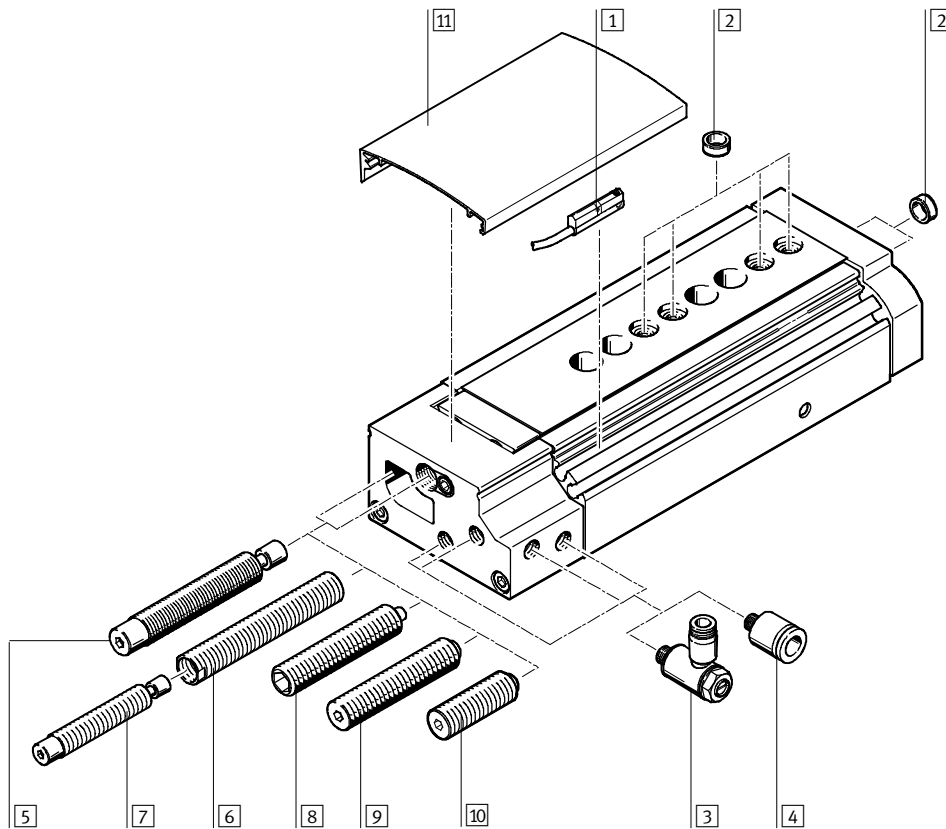

- | | | |
|-----------------------------------|------------------------|-----------------|
| 1 Proximity sensor SME-/SMT-10 | 4 Push-in fitting QS | 8 Cushioning P1 |
| 2 Centring sleeve ZBH | 5 Cushioning Y3 | 9 Cushioning P |
| 3 One-way flow control valve GRLA | 6 Reducing sleeve DAYH | 10 Cushioning E |
| | 7 Shock absorber DYSW | 11 Cover DADS |

		→ Page/online
1	Proximity sensor SME-/SMT-10	256
2	Centring sleeve ZBH	256
3	One-way flow control valve GRLA	256
4	Push-in fitting QS	908
5	Cushioning Y3	256
6	Reducing sleeve DAYH	256
7	Shock absorber DYSW	256
8	Cushioning P1	256

		→ Page/online
9	Cushioning P	256
10	Cushioning E	256
11	Cover DADS	257
-	Connector sleeve ZBV	257
-	Connecting cable NEBU	257
-	Drive/drive connections	adapter kit
-	Drive/gripper connections	adapter kit

Shock absorber selection

Depending on the effective load, the mini slide DGSL offers the opportunity to replace the shock absorbers and therefore influence the cushioning behaviour.

This is done by removing the existing shock absorbers on the DGSL and replacing them with a smaller shock absorber as appropriate to the application.

With smaller loads, the next smaller shock absorber DYSW can be installed with the help of the reducing sleeve DAYH.

With very small loads, the shock absorber DYEF can be installed.

Accessories – Ordering data

1

	For size		Part No.	Type
1 Proximity sensor for C-slot, magneto-resistive – N/O contact				
	PNP, cable	★	551373	SMT-10M-PS-24V-E-2,5-L-OE
	PNP, plug	★	551375	SMT-10M-PS-24V-E-0,3-L-M8D
Magnetic reed – N/O contact				
	Plug	★	551367	SME-10M-DS-24V-E-0,3-L-M8D
	Cable	★	551365	SME-10M-DS-24V-E-2,5-L-OE
	Cable	★	551369	SME-10M-ZS-24V-E-2,5-L-OE

	For size		Part No.	Type
2 Centring sleeve¹⁾				
	4, 6		189652	ZBH-5
	8, 10, 12, 16		186717	ZBH-7
	20, 25		150927	ZBH-9

1) Packaging unit 10 pieces.

Note

Proximity sensors SME are not permitted with size 4.

Function	For size	Connection		Part No.	Type
		Thread	O.D.		
3 One-way flow control valve with slotted head screw, metal²⁾ for exhaust air flow control					
	4, 6, 8	M3	3	175041	GRLA-M3-QS-3 ³⁾
			–	175038	GRLA-M3
	10, 12, 16	M5	4	★ 193138	GRLA-M5-QS-4-D
			6	★ 193144	GRLA-1/8-QS-6-D
20, 25	G1/8	6	162965	GRLA-1/8-QS-6-RS-B	
		8	162966	GRLA-1/8-QS-8-RS-B	

Technical data → 609

2) The recommended flow control valves are based on a tubing length to the valve of 1 m. For deviations of ±50%, flow control valves with a bigger or smaller flow rate must be selected to guarantee the optimum flow control function and cylinder speed.



3) Only one GRLA-M3-QS-3 can be mounted on the front with size 4.

	For size		Part No.	Type
5/7 Shock absorber Y3				
	8		548070	DYSW-4-6-Y1F
	10		548071	DYSW-5-8-Y1F
	12		548072	DYSW-7-10-Y1F
	16		548073	DYSW-8-14-Y1F
	20		548074	DYSW-10-17-Y1F
	25		548075	DYSW-12-20-Y1F
6 Reducing sleeve DAYH				
	10		1165476	DAYH-4
	12		1165480	DAYH-5
	16		1165484	DAYH-7
	20		1165488	DAYH-8
	25		1165491	DAYH-10
8 Shock absorber P1				
	4		548370	DYEF-M4-Y1F
	6		548371	DYEF-M5-Y1F
	8		548372	DYEF-M6-Y1F
	10		548373	DYEF-M8-Y1F
	12		548374	DYEF-M10-Y1F
	16		548375	DYEF-M12-Y1F
	20		548376	DYEF-M14-Y1F
	25		548377	DYEF-M16-Y1F

	For size		Part No.	Type	
9 Shock absorber P					
	4		1152500	DYEF-M4-Y1	
	6		1152507	DYEF-M5-Y1	
	8		1152524	DYEF-M6-Y1	
	10		1152536	DYEF-M8-Y1	
	12		1179837	DYEF-M10-Y1	
	16		1179840	DYEF-M12-Y1	
	20		1179863	DYEF-M14-Y1	
	25		1179879	DYEF-M16-Y1	
	10 Shock absorber E				
		4		1152500	DYEF-S-M4-Y1
6			1152507	DYEF-S-M5-Y1	
8			1152524	DYEF-S-M6-Y1	
10			1152536	DYEF-S-M8-Y1	
12			1152959	DYEF-S-M10-Y1	
16			1153004	DYEF-S-M12-Y1	
20			1153017	DYEF-S-M14-Y1	
25			1153023	DYEF-S-M16-Y1	

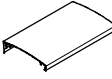
Accessories – Ordering data

	For size	Length [mm]	Part No.	Type
11 Cover				Dimensions online: → dgs
	4	30	1086663	DADS-AB-G6-4-30
		500	1212468	DADS-AB-G6-4-500
	6	50	1066625	DADS-AB-G6-6-50
		500	1212476	DADS-AB-G6-6-500
	8	80	1087413	DADS-AB-G6-8-80
		500	1212478	DADS-AB-G6-8-500
	10	50	1162400	DADS-AB-G6-10-50
		100	1090689	DADS-AB-G6-10-100
		500	1212479	DADS-AB-G6-10-500
	12	50	1162406	DADS-AB-G6-12-50
		150	1090732	DADS-AB-G6-12-150
		500	1212480	DADS-AB-G6-12-500
	16	50	1162410	DADS-AB-G6-16-50
		150	1066591	DADS-AB-G6-16-150
		500	1212503	DADS-AB-G6-16-500
	20	50	1162412	DADS-AB-G6-20-50
		100	1162415	DADS-AB-G6-20-100
		200	1090823	DADS-AB-G6-20-200
		500	1212521	DADS-AB-G6-20-500
	25	50	1162417	DADS-AB-G6-25-50
100		1162419	DADS-AB-G6-25-100	
200		1090895	DADS-AB-G6-25-200	
500		1212523	DADS-AB-G6-25-500	

	For size		Part No.	Type
Connector sleeve¹⁾				
	8, 10		189652	ZBV-M4-7
	12, 16		186717	ZBV-M5-7
	20, 25		150927	ZBV-M6-9
Connecting cable, straight socket				Technical data → 949
	2.5 m	★	541333	NEBU-M8G3-K-2.5-LE3
	5.0 m	★	541334	NEBU-M8G3-K-5-LE3
Angled socket				Technical data → 949
	2.5 m	★	541338	NEBU-M8W3-K-2.5-LE3
	5.0 m	★	541341	NEBU-M8W3-K-5-LE3

1) Packaging unit 3 pieces.

Mini slides DGSL

Dimensions

1 Size 4 ... 10

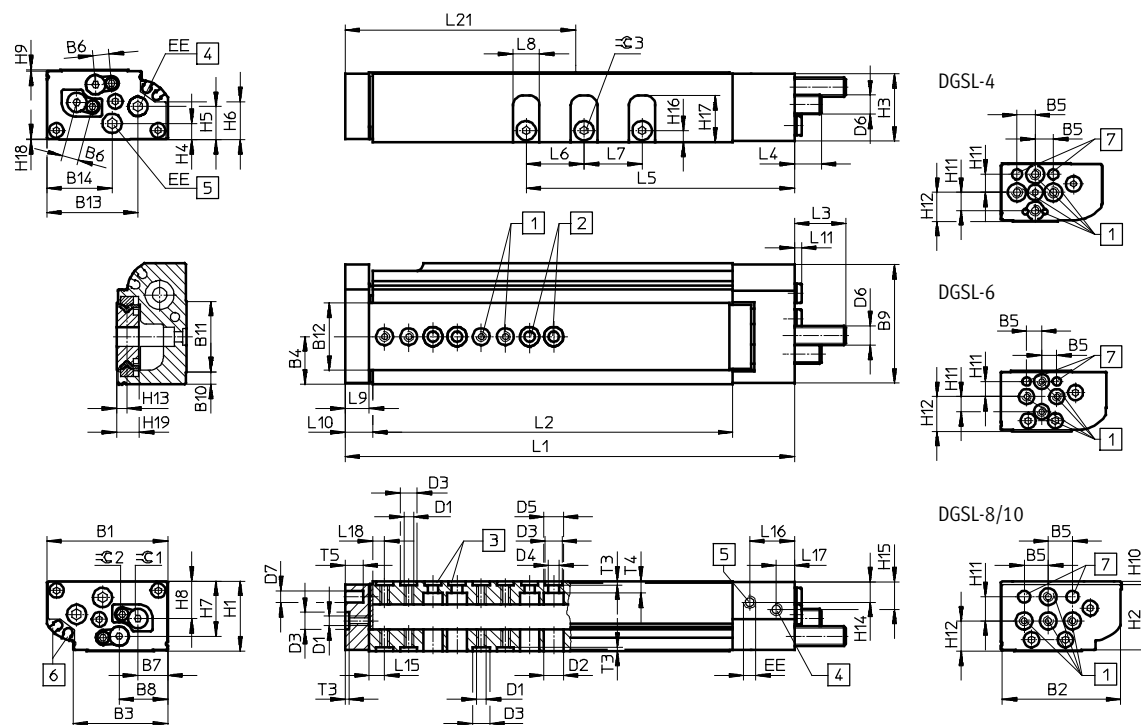

- 1 Mounting thread (centring sleeves included in the scope of delivery)
- 2 Through-holes for mounting the drive
- 3 Centring holes (centring sleeves included in the scope of delivery)
- 4 Supply port, advancing
- 5 Supply port, retracting
- 6 Slots for proximity sensor SME/SMT-10
- 7 Centring hole
- L10 Distance between outer edge of yoke plate and housing
- L15 Distance between centre of centring hole and outer edge of slide
- L18 Distance between centre of centring hole and outer edge of housing

General dimensions

Size	B1	B2	B3	B4	B5	B6	B7	B8	B9	B10	B11	B12	B13	B14	D1
4	28	27.4	18.1	9.4	5	3.55	6.3	11.95	27.5	2	17.2	12.4	23.15	16.15	M3
6	35	34.5	26	13.5	5	5	8.2	13.5	34.5	3.5	19.9	20	28.1	18.9	M3
8	42	41.3	31.2	16.6	10	6	10.3	16.25	41.5	4.5	24	24.1	33	24.4	M4
10	50	49	39.2	19.65	10	6.8	12.35	20.1	49	5	29.2	28	37.7	27	M4

Size	D2	D3	D4	D5	D6	D7	EE	H1	H2	H3	H4	H5	H6	H7	H8
	∅	∅	∅	∅		∅		±0.08							
4	6.2	5 ^{H7}	3.3	6	M4x0.5	3 ^{H7}	M3	16	15.4	15.1	3.85	6.3	8.6	8.4	8.1
6	6.2	5 ^{H7}	3.3	6	M5x0.5	3 ^{H7}	M3	20	19	19.25	4.7	7.8	10.2	16	10.55
8	8	7 ^{H7}	4.3	8	M6x0.5	5 ^{H7}	M3	24	22.7	23	6.5	10.6	14	18.9	13.3
10	8	7 ^{H7}	4.3	8	M8x1	5 ^{H7}	M5	29	27.1	28	6.8	13.8	15.8	22.8	15.5

Size	H9	H10	H11	H12	H13	H14	H15	H16	H17	H18	H19	T3	T4	T5	≈∅ 2	≈∅ 3
												+0.1				
4	0.65	0.3	5	8	2.7	5.35	5.85	3	10.6	0.25	5.3	1.3	2.3	4	1.3	2
6	0.5	0.5	5	11.5	3.4	6.5	7.2	3.7	13.1	0.27	6.5	1.3	3.3	6	1.5	2.5
8	0.6	0.9	10	8.7	3.25	7.8	10.5	4.1	16.8	0.35	6.6	1.6	3.8	7.5	2	2.5
10	0.6	1.4	10	12.5	4.2	8.75	11.75	4.8	19.25	0.4	9	1.6	5	7.5	2.5	3

Dimensions

Download CAD data → www.festo.com

1

Stroke-dependent dimensions															
Size	Stroke	L1	L2	L5	L6	L7	L8	L9	L10	L11	L15 ±0.05	L16	L17	L18 ±0.05	L21
4	10	72.1	48	36.35	–	–	6.5	5.5	6.6	2.5	4	13.25	4.25	3	31
	20	81.2	57.1	37.95	10										36
	30	91.2	67.1	47.95	11										42
6	10	81.1	54	33.1	–	14	8	8	9.6	2.5	5.1	13.25	4.25	3.5	37
	20	91.1	64	43.1	42										
	30	101.1	74	53.1	47										
	40	111.1	84	63.1	52										
	50	121.1	94	73.1	57										
8	10	90.2	59.6	34.6	–	–	8	10	11.6	2.5	7	14.65	4.35	5.5	41
	20	100.2	69.6	44.6	10										46
	30	110.2	79.6	54.6	16										51
	40	120.2	89.6	64.6	56										
	50	142.2	111.6	74.6	67										
	80	172.2	141.6	104.6	10										82
	100	206.2	169.1	131	24										24
10	10	103.1	66	41.3	–	–	11	10	11.6	2.5	6.4	18.5	7	5	43
	20	112.8	75.7	51	46										
	30	122.8	85.7	61	51										
	40	132.8	95.7	71	56										
	50	142.8	105.7	81	61										
	80	186.2	149.1	111	24										83
	100	206.2	169.1	131	24										24

Cushioning-dependent dimensions					
Size	Cushioning	L3 max.	L4 max.	≈ 1	
				For adjusting the cushioning stroke	For adjusting the end position
4	P	15.2	7.8	–	1.3
	E	5.7	0	–	1.3
	P1	14	6	1.3	2.5
6	P	17.6	8.1	–	1.5
	E	6.6	0	–	1.5
	P1	15.5	5.8	1.5	3
8	P	21.1	10.7	–	2
	E	6.6	0	–	2
	P1	19	9.1	2	4
	Y3	24.3	23.9	–	2
10	P	22.8	12.5	–	2.5
	E	8.8	0	–	2.5
	P1	20.5	10.2	2.5	5
	Y3	25.5	14.9	–	2.5
	Y11	30.4	19.9	–	2

Mini slides DGSL

Dimensions

1 Hole pattern for mounting threads and centring holes

DGSL-4-10

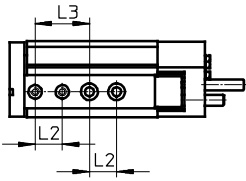

DGSL-4-20

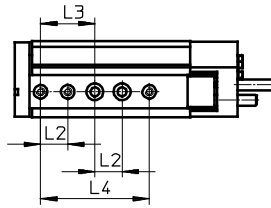

DGSL-4-30

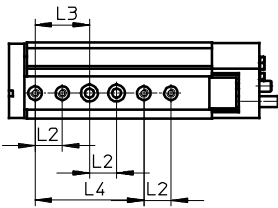

DGSL-6-10

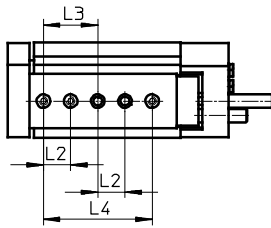

DGSL-6-20

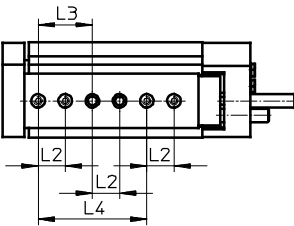

DGSL-6-30

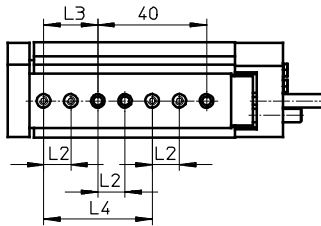

DGSL-6-40/50

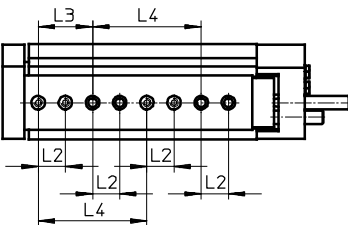

DGSL-8-10

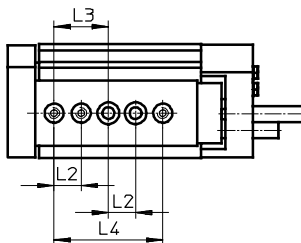

DGSL-8-20

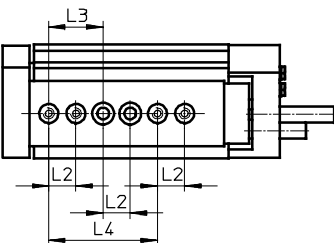

DGSL-8-30

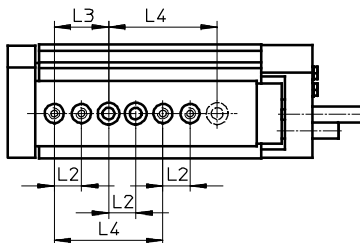

Dimensions

Hole pattern for mounting threads and centring holes

DGSL-8-40

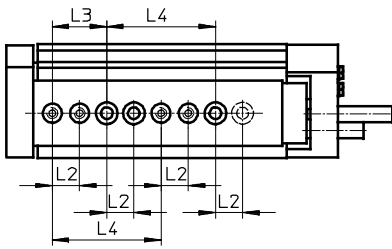

DGSL-8-50/80

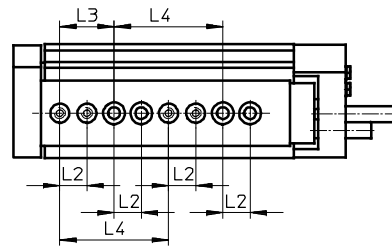

DGSL-10-10

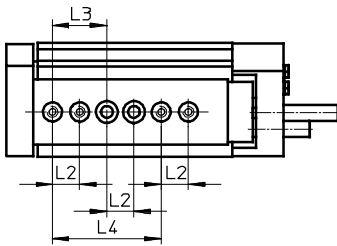

DGSL-10-20

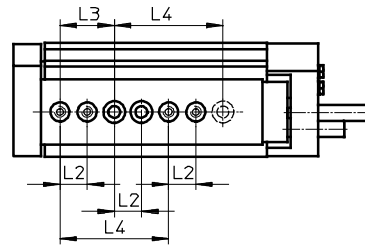

DGSL-10-30

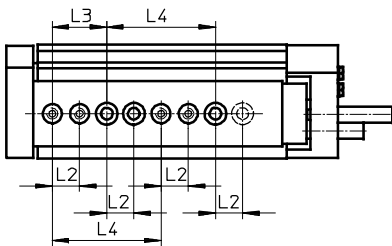

DGSL-10-40 ... 100

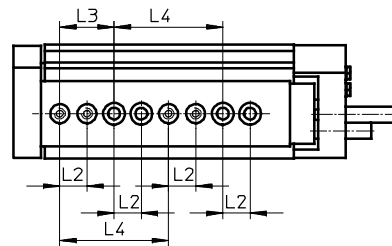

Distances from the yoke plate to the mounting threads and centring holes

DGSL-4 ... 10

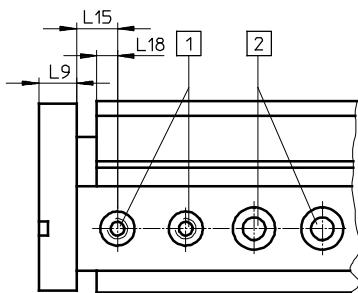

- 1 Centring holes with thread
- 2 Through-holes for mounting the drive

Size	L2 ¹⁾	L3 ¹⁾	L4 ¹⁾	L9	L15 ±0.05	L18
4	10	20	40	5.5	4	3
6				8	5.1	3.5
8				10	7	5.5
10				10	6.4	5

1) Tolerance for centring hole ±0.02.
Tolerance for through-hole ±0.1.

Mini slides DGSL

Dimensions

1 Size 12/16

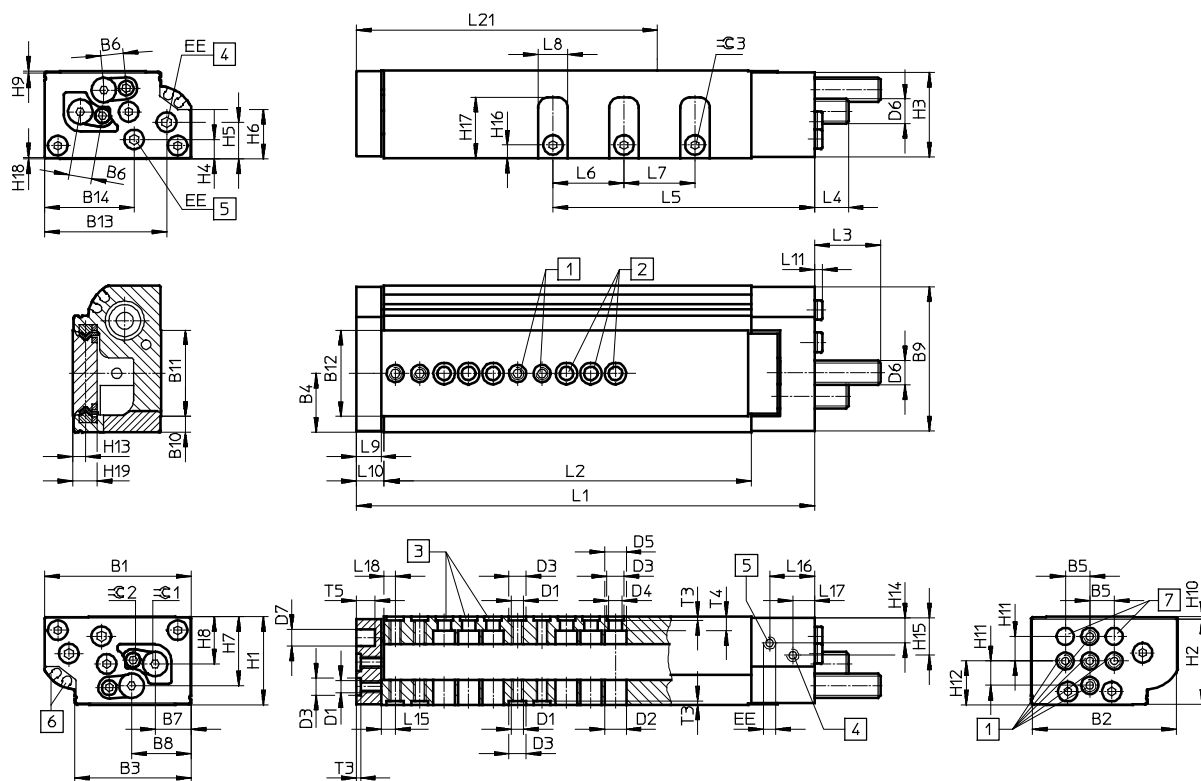

- 1 Mounting thread (centring sleeves included in the scope of delivery)
- 2 Through-holes for mounting the drive
- 3 Centring holes (centring sleeves included in the scope of delivery)
- 4 Supply port, advancing
- 5 Supply port, retracting
- 6 Slots for proximity sensor SME/SMT-10
- 7 Centring hole
- L10 Distance between outer edge of yoke plate and housing
- L15 Distance between centre of centring hole and outer edge of slide
- L18 Distance between centre of centring hole and outer edge of housing

General dimensions

Size	B1	B2	B3	B4	B5	B6	B7	B8	B9	B10	B11	B12	B13	B14	D1
12	60	59	47.6	24	10	9.2	14.7	24.3	59	6.4	35.35	35.2	50	36.7	M5
16	66	65	53.5	26.7	10	11.1	16.7	27.5	65	7.75	37.9	38	50.4	36.7	M5

Size	D2	D3	D4	D5	D6	D7	EE	H1	H2	H3	H4	H5	H6	H7	H8
12	8.8	7 ^{H7}	5.5	8.8	M10x1	8 ^{H7}	M5	36 ±0.08	34.8	34.7	8	15.1	20.35	28.2	19.3
16	8.8	7 ^{H7}	5.5	9.2	M12x1	8 ^{H7}	M5	40	38	39	8.5	16.7	20.6	31.7	20.8

Size	H9	H10	H11	H12	H13	H14	H15	H16	H17	H18	H19	T3	T4	T5	≙ 2	≙ 3
12	0.8	0.95	10	17.9	5.2	10.75	15.75	5.5	24.9	0.5	10	1.6 +0.1	5.6	7.5	3	3
16	0.5	1.5	10	20	6.4	10.5	16.7	7	26.6	0.5	12.4	1.6	6.1	9	4	4

Dimensions

1

Stroke-dependent dimensions															
Size	Stroke	L1	L2	L5	L6	L7	L8	L9	L10	L11	L15 ±0.05	L16	L17	L18 ±0.05	L21
12	10	106.2	68.6	42.4	-	-	12	10	11.6	2.5	5.8	18.5	7.5	4.5	44
	20	116.2	78.6	52.4											49
	30	126.2	88.6	62.4											54
	40	136.2	98.6	72.4											59
	50	146.2	108.6	82.4	29										64
	80	197.6	160	112.4											88
	100	217.6	180	132.4											98
	150	267.6	230	182.4											29
16	10	124.1	82.5	45	-	-	14	12	13.6	2.5	6.8	21	7	5.5	54
	20	134.6	93	54.6											59
	30	144.6	103	64.6											64
	40	154.6	113	74.6											69
	50	164.6	123	84.6	35										74
	80	194.6	153	114.6											89
	100	243.6	202	134.6											113
	150	293.6	252	184.6											138

Cushioning-dependent dimensions					
Size	Cushioning	L3 max.	L4 max.	≈ 1	
				For adjusting the cushioning stroke	For adjusting the end position
12	P	28.1	14.9	-	3
	E	8.8	0	-	3
	P1	26	12.8	3	6
	Y3	36.9	23.7	-	3
	Y11	42.2	18.7	-	2.5
16	P	42.3	26.1	-	4
	E	8.8	0	-	4
	P1	40	23.8	4	8
	Y3	51.9	35.7	-	4
	Y11	55.4	38.9	-	3

Mini slides DGSL

Dimensions

1 Hole pattern for mounting threads and centring holes

DGSL-12-10

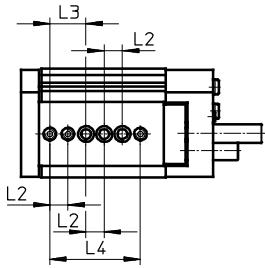

DGSL-12-20

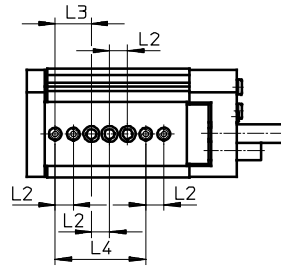

DGSL-12-30

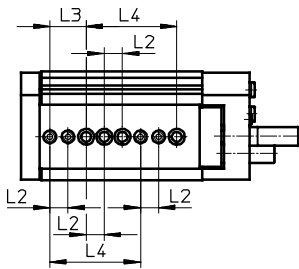

DGSL-12-40

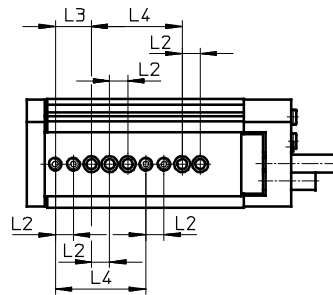

DGSL-12-50 ... 100

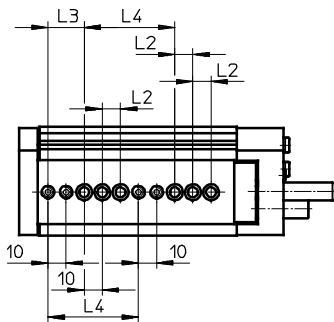

DGSL-12-150

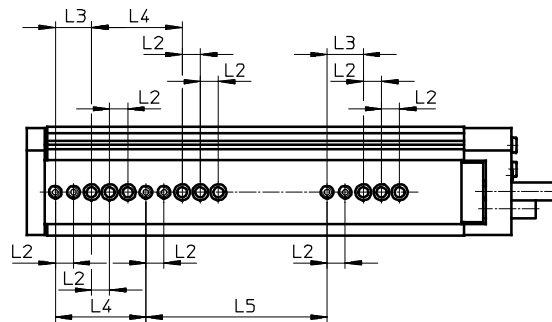

DGSL-16-10

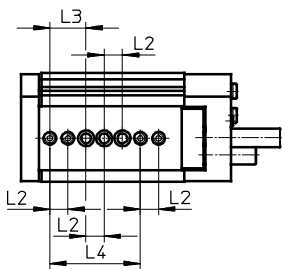

DGSL-16-20

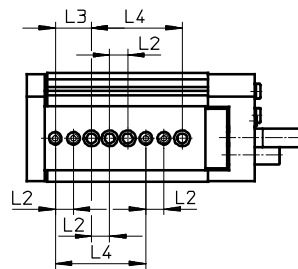

Dimensions

Hole pattern for mounting threads and centring holes

DGSL-16-30

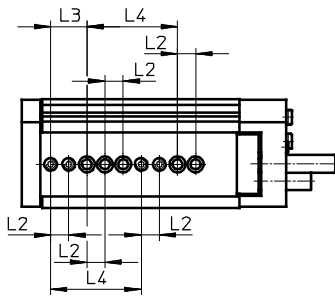

DGSL-16-40 ... 100

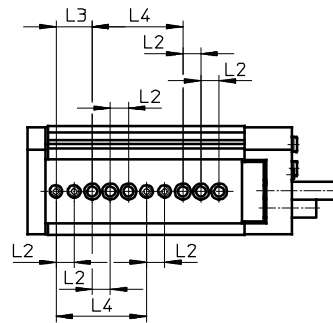

DGSL-16-150

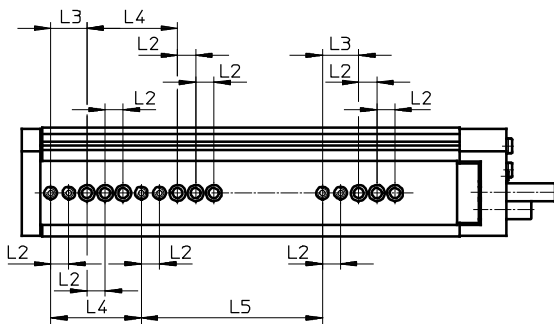

Distances from the yoke plate to the mounting threads and centring holes

DGSL-12/16

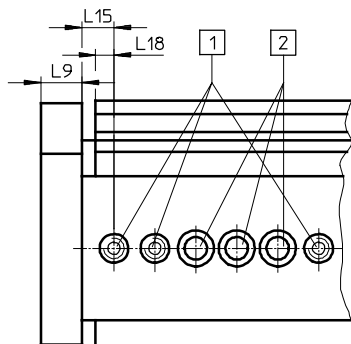

- 1 Centring holes with thread
- 2 Through-holes for mounting the drive

Size	L2 ¹⁾	L3 ¹⁾	L4 ¹⁾	L5 ¹⁾	L9	L15 ±0.05	L18
12	10	20	50	100	10	5.8	4.5
16					12	6.8	5.5

1) Tolerance for centring hole ±0.02.
Tolerance for through-hole ±0.1.

Mini slides DGSL

Dimensions

1 Size 20/25

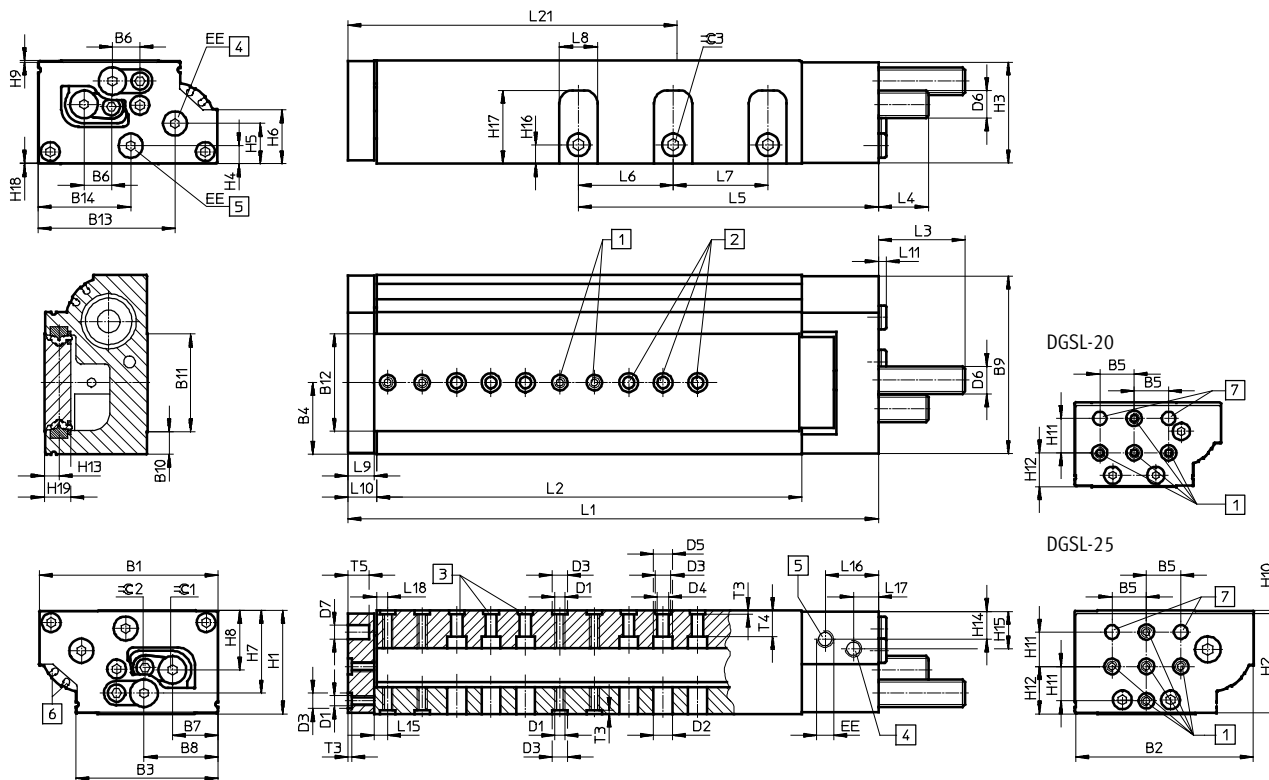

- 1 Mounting thread (centring sleeves included in the scope of delivery)
- 2 Through-holes for mounting the drive
- 3 Centring holes (centring sleeves included in the scope of delivery)
- 4 Supply port, advancing
- 5 Supply port, retracting
- 6 Slots for proximity sensor SME/SMT-10
- 7 Centring hole
- L10 Distance between outer edge of yoke plate and housing
- L15 Distance between centre of centring hole and outer edge of slide
- L18 Distance between centre of centring hole and outer edge of housing

General dimensions

Size	B1	B2	B3	B4	B5	B6	B7	B8	B9	B10	B11	B12	B13	B14	D1
20	85	84	68.85	34.5	20	14	21.4	36.35	83.4	10	48.9	49.2	64.1	48.6	M6
25	104	103	82.6	41.6	20	16.2	26.4	43.1	103	13.25	56.5	56.7	79.4	53.7	M6

Size	D2	D3	D4	D5	D6	D7	EE	H1	H2	H3	H4	H5	H6	H7	H8
	∅	∅	∅	∅		∅		±0.08							
20	11	9 ^{H7}	6.6	11	M14x1	8 ^{H7}	G ¹ / ₈	49	46.5	47.7	10.3	20.6	23.2	38.2	26.1
25	11	9 ^{H7}	6.6	11	M16x1	8 ^{H7}	G ¹ / ₈	60	57.5	58.5	10.5	23.4	31.2	48	34.5

Size	H9	H10	H11	H12	H13	H14	H15	H16	H17	H18	H19	T3	T4	T5	∅ 2	∅ 3
20	0.5	2	20	19.6	7.55	14.7	14.7	10	33.3	0.8	14.5	2.1	8.8	10	4	5
25	1	2	20	27.5	8.55	16.6	22.2	11	42.7	0.5	15.5	2.1	15.1	12	5	6

Dimensions

Download CAD data → www.festo.com

1

Stroke-dependent dimensions																
Size	Stroke	L1	L2	L5	L6	L7	L8	L9	L10	L11	L15 ±0.05	L16	L17	L18 ±0.05	L21	
20	10	141.2	84.6	59.1	-	-	17	14	15.6	4.6	7.8	29.3	10.5	6.5	56	
	20	151.2	94.6	69.1											61	
	30	161.2	104.6	79.1											66	
	40	171.2	114.6	89.1											71	
	50	183.2	126.6	99.1											76	
	80	211.2	154.6	129.1											91	
	100	270.2	213.6	149.1											44	121
	150	333.2	276.6	199.1											44	152
	200	383.2	326.6	252.1											44	177
25	10	157.1	96	63.7	-	-	22	15	16.6	4.6	8	30.9	12.2	6.5	64	
	20	167.1	106	72.2											69	
	30	177.1	116	82.2											74	
	40	187.1	126	92.2											79	
	50	197.1	136	102.2											84	
	80	253.1	192	132.2											55	112
	100	286.1	225	152.2											129	
	150	338.1	277	202.2											154	
	200	388.1	327	254.2											179	

Cushioning-dependent dimensions					
Size	Cushioning	L3 max.	L4 max.	≈ 1	
				For adjusting the cushioning stroke	For adjusting the end position
20	P	52.4	31.2	-	4
	E	8.8	0	-	4
	P1	50.1	28.9	4	8
	Y3	55.5	34.3	-	4
	Y11	67.4	45.9	-	4
25	P	51.9	30.5	-	5
	E	8.8	0	-	5
	P1	49.6	28.2	5	10
	Y3	65.2	43.8	-	5
	Y11	78.4	56.9	-	4

Mini slides DGSL

Dimensions

1 Hole pattern for mounting threads and centring holes

DGSL-20-10/20

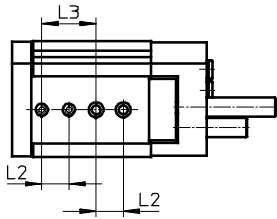

DGSL-20-30/40

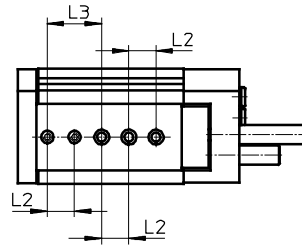

DGSL-20-50

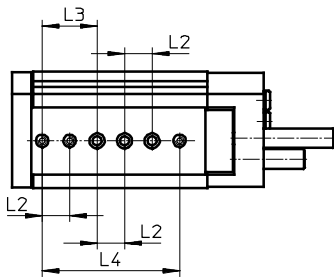

DGSL-20-80

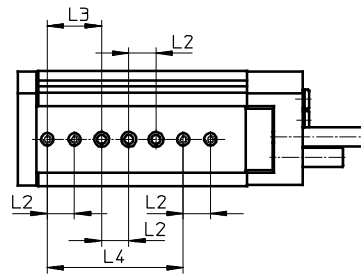

DGSL-20-100 ... 200

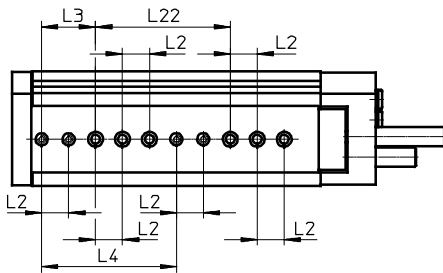

DGSL-25-10

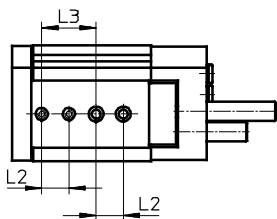

DGSL-25-20

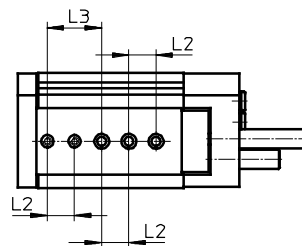

Dimensions

Hole pattern for mounting threads and centring holes

DGSL-25-30/40

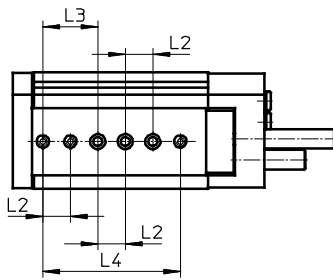

DGSL-25-50

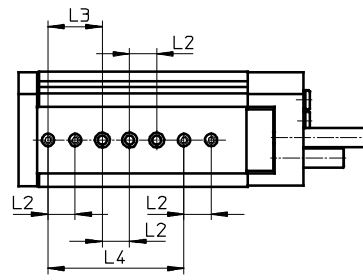

DGSL-25-80

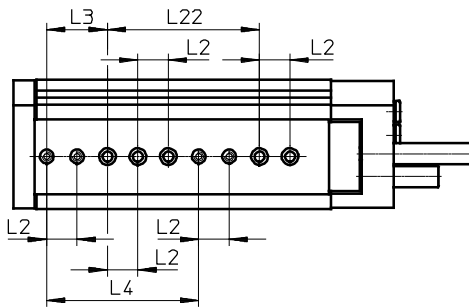

DGSL-25-100 ... 200

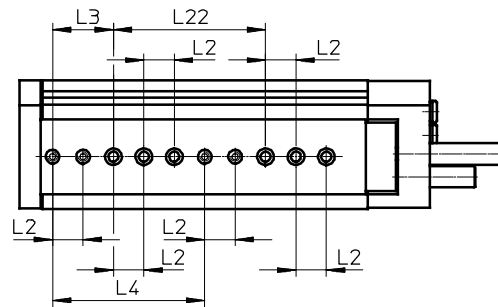

Distances from the yoke plate to the mounting threads and centring holes

DGSL-20/25

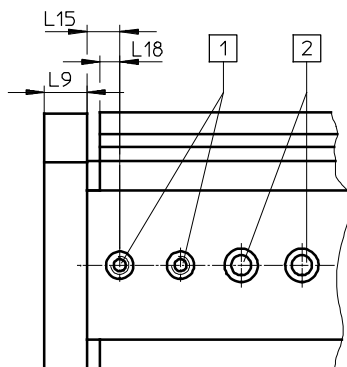

- 1 Centring holes with thread
- 2 Through-holes for mounting the drive

Size	L2 ¹⁾	L3 ¹⁾	L4	L9	L15 ±0.05	L18	L22
20	20	40	100 ¹⁾	14	7.8	6.5	100±0.03
25	20	40	100±0.03	15	8	6.5	100 ¹⁾

1) Tolerance for centring hole ±0.02.
Tolerance for through-hole ±0.1.

Mini slides DGSL

Download CAD data → www.festo.com

Dimensions

1 C – Clamping unit/E3 – End-position locking

4 Supply port

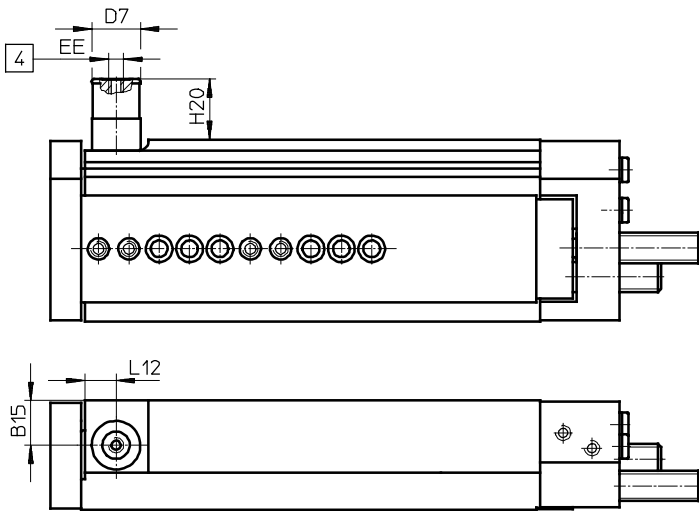

Size	B15	D7 Ø	EE	H20		L12
				C	E3	
6	7.2	12	M5	10.7	21.2	7.3
8	9.9	12		10.5	21	7.3
10	11.2	16		11.8	21.2	10.5
12	14.8	16		10.5	19.9	10.3
16	14	20		27.5	30.5	13
20	17	20		21.3	24.3	14
25	22.55	20		17.75	20.65	14



- Sturdy and precise
- With plain-bearing or recirculating ball bearing guide
- High resistance to torques and lateral forces
- Wide range of applications
- Spare parts service
- ★ Quick ordering of basic designs → 273

→ www.festo.com/catalogue/dfm

Product range overview

Type/function	Piston Ø [mm]	Stroke [mm]	Force [N]	Product options	
				P	A
Double-acting	DFM-...-GF – Plain-bearing guide				
	12, 16, 20, 25, 32, 40, 50, 63, 80, 100	10 ... 200	68 ... 4,712	■	■
Double-acting	DFM-...-KF – Recirculating ball bearing guide				
	12, 16, 20, 25, 32, 40, 50, 63, 80, 100	10 ... 200	68 ... 4,712	■	■

Product options

P Elastic cushioning rings/pads at both ends A Position sensing

Technical data

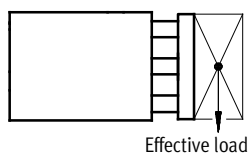
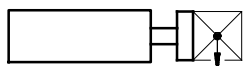
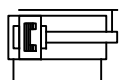

Effective load

Technical data						Dimensions → 276
Piston Ø	12	16	20	25	32	
Pneumatic connection	M5	M5	M5	G1/8	G1/8	
Cushioning	Elastic cushioning rings/pads at both ends					
Theoretical force at 6 bar, advancing	[N]	68	121	188	295	482
Theoretical force at 6 bar, retracting	[N]	51	90	141	247	415
Max. effective load ¹⁾	[N]	19 ... 28	24 ... 73	35 ... 110	84 ... 123	112 ... 188
Torque load ¹⁾	[Nm]	0.38 ... 0.65	0.55 ... 1.68	1.01 ... 3	2.85 ... 4.2	4.25 ... 7.3
Protection against rotation	Guide rod with yoke, with plain-bearing or recirculating ball bearing guide					

Piston Ø	40	50	63	80	100	
Pneumatic connection	G1/8	G1/4	G1/4	G3/8	G3/8	
Cushioning	Flexible cushioning rings/pads at both ends					
Theoretical force at 6 bar, advancing	[N]	754	1,178	1,870	3,016	4,712
Theoretical force at 6 bar, retracting	[N]	686	1,057	1,750	2,827	4,418
Max. effective load ¹⁾	[N]	109 ... 180	168 ... 257	168 ... 257	220 ... 352	332 ... 568
Torque load ¹⁾	[Nm]	4.80 ... 7.90	9.30 ... 14.15	10.50 ... 15.90	17.10 ... 27.20	25.70 ... 53.40
Protection against rotation	Guide rod with yoke, with plain-bearing or recirculating ball bearing guide					

1) Dependent on stroke.

Guided drives DFM

1

Technical data

Operating conditions			12	16	20	25	32	40	50	63	80	100		
Piston Ø														
Operating pressure	[bar]		2 ... 10				1.5 ... 10			1 ... 10			0.5 ... 10	
Ambient temperature ²⁾	GF	[°C]	-20 ... +80											
	KF	[°C]	-5 ... +60											

2) Note operating range of proximity sensors.

Materials	
Piston rod	High-alloy stainless steel
Housing	Wrought aluminium alloy
End cap	Wrought aluminium alloy
Yoke plate	Galvanised steel
Seals	NBR

Order code

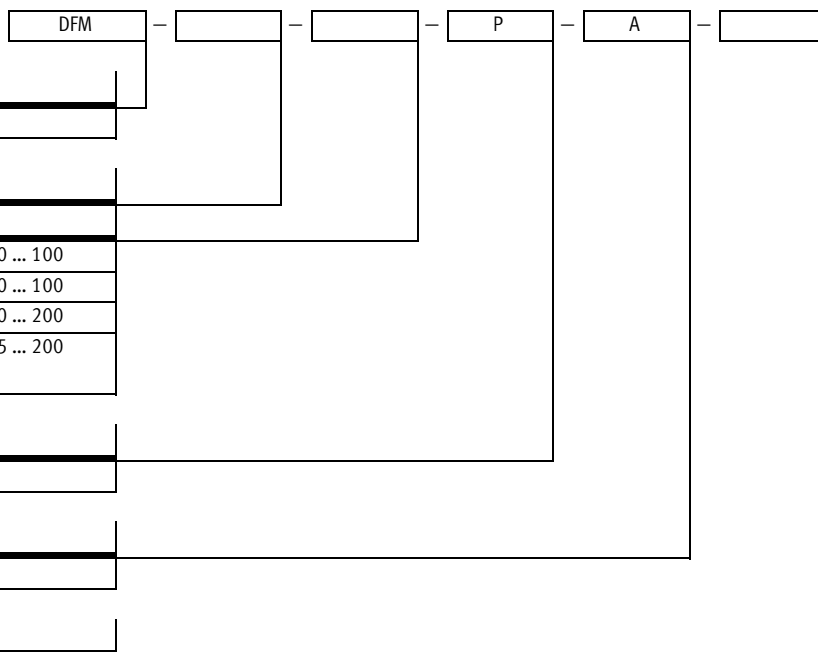

Type	
DFM	Guided drive

Piston Ø [mm]	
	Stroke [mm]
12, 16	10, 20, 25, 30, 40, 50, 80, 100 10 ... 100
20, 25	20, 25, 30, 40, 50, 80, 100 20 ... 100
32	20, 25, 30, 40, 50, 80, 100, 125, 160, 200 20 ... 200
40, 50, 63, 80, 100	25, 50, 80, 100, 125, 160, 200 25 ... 200

Cushioning	
P	Elastic cushioning rings/pads at both ends

Position sensing	
A	Via proximity sensor

Guide	
GF	Plain-bearing guide
KF	Recirculating ball bearing guide

Ordering – Product options



Configurable product

This product and all its options can be ordered using the configurator.

The configurator can be found under Products on the DVD or
[→ www.festo.com/catalogue/...](http://www.festo.com/catalogue/...)

Enter the type code in the search field.

★ Quick ordering

GF – Plain-bearing guide

Part No.	Type
Piston Ø 12 mm	
170824	DFM-12-10-P-A-GF
170825	DFM-12-20-P-A-GF
170826	DFM-12-25-P-A-GF
170827	DFM-12-30-P-A-GF
170828	DFM-12-40-P-A-GF
170829	DFM-12-50-P-A-GF
170830	DFM-12-80-P-A-GF
170831	DFM-12-100-P-A-GF
Piston Ø 16 mm	
170832	DFM-16-10-P-A-GF
170833	DFM-16-20-P-A-GF
170834	DFM-16-25-P-A-GF
170835	DFM-16-30-P-A-GF
170836	DFM-16-40-P-A-GF
170837	DFM-16-50-P-A-GF
170838	DFM-16-80-P-A-GF
170839	DFM-16-100-P-A-GF
Piston Ø 20 mm	
170840	DFM-20-20-P-A-GF
170841	DFM-20-25-P-A-GF
170842	DFM-20-30-P-A-GF
170843	DFM-20-40-P-A-GF
170844	DFM-20-50-P-A-GF
170845	DFM-20-80-P-A-GF
170846	DFM-20-100-P-A-GF

Part No.	Type
Piston Ø 25 mm	
170847	DFM-25-20-P-A-GF
170848	DFM-25-25-P-A-GF
170849	DFM-25-30-P-A-GF
170850	DFM-25-40-P-A-GF
170851	DFM-25-50-P-A-GF
170852	DFM-25-80-P-A-GF
170853	DFM-25-100-P-A-GF
Piston Ø 32 mm	
170854	DFM-32-20-P-A-GF
170855	DFM-32-25-P-A-GF
170856	DFM-32-30-P-A-GF
170857	DFM-32-40-P-A-GF
170858	DFM-32-50-P-A-GF
170859	DFM-32-80-P-A-GF
170860	DFM-32-100-P-A-GF
170861	DFM-32-125-P-A-GF
170862	DFM-32-160-P-A-GF
170863	DFM-32-200-P-A-GF

Part No.	Type
Piston Ø 40 mm	
170864	DFM-40-25-P-A-GF
170865	DFM-40-50-P-A-GF
170866	DFM-40-80-P-A-GF
170867	DFM-40-100-P-A-GF
170868	DFM-40-125-P-A-GF
170869	DFM-40-160-P-A-GF
170870	DFM-40-200-P-A-GF
Piston Ø 50 mm	
170871	DFM-50-25-P-A-GF
170872	DFM-50-50-P-A-GF
170873	DFM-50-80-P-A-GF
170874	DFM-50-100-P-A-GF
170875	DFM-50-125-P-A-GF
170876	DFM-50-160-P-A-GF
170877	DFM-50-200-P-A-GF
Piston Ø 63 mm	
170878	DFM-63-25-P-A-GF
170879	DFM-63-50-P-A-GF
170880	DFM-63-80-P-A-GF
170881	DFM-63-100-P-A-GF
170882	DFM-63-125-P-A-GF
170883	DFM-63-160-P-A-GF
170884	DFM-63-200-P-A-GF

KF – Recirculating ball bearing guide

Part No.	Type
Piston Ø 12 mm	
170899	DFM-12-10-P-A-KF
170900	DFM-12-20-P-A-KF
170901	DFM-12-25-P-A-KF
170902	DFM-12-30-P-A-KF
170903	DFM-12-40-P-A-KF
170904	DFM-12-50-P-A-KF
170905	DFM-12-80-P-A-KF
170906	DFM-12-100-P-A-KF
Piston Ø 16 mm	
170907	DFM-16-10-P-A-KF
170908	DFM-16-20-P-A-KF
170909	DFM-16-25-P-A-KF
170910	DFM-16-30-P-A-KF
170911	DFM-16-40-P-A-KF
170912	DFM-16-50-P-A-KF
170913	DFM-16-80-P-A-KF
170914	DFM-16-100-P-A-KF
Piston Ø 20 mm	
170915	DFM-20-20-P-A-KF
170916	DFM-20-25-P-A-KF
170917	DFM-20-30-P-A-KF
170918	DFM-20-40-P-A-KF
170919	DFM-20-50-P-A-KF
170920	DFM-20-80-P-A-KF
170921	DFM-20-100-P-A-KF

Part No.	Type
Piston Ø 25 mm	
170922	DFM-25-20-P-A-KF
170923	DFM-25-25-P-A-KF
170924	DFM-25-30-P-A-KF
170925	DFM-25-40-P-A-KF
170926	DFM-25-50-P-A-KF
170927	DFM-25-80-P-A-KF
170928	DFM-25-100-P-A-KF
Piston Ø 32 mm	
170929	DFM-32-20-P-A-KF
170930	DFM-32-25-P-A-KF
170931	DFM-32-30-P-A-KF
170932	DFM-32-40-P-A-KF
170933	DFM-32-50-P-A-KF
170934	DFM-32-80-P-A-KF
170935	DFM-32-100-P-A-KF
170936	DFM-32-125-P-A-KF
170937	DFM-32-160-P-A-KF
170938	DFM-32-200-P-A-KF

Part No.	Type
Piston Ø 40 mm	
170939	DFM-40-25-P-A-KF
170940	DFM-40-50-P-A-KF
170941	DFM-40-80-P-A-KF
170942	DFM-40-100-P-A-KF
170943	DFM-40-125-P-A-KF
170944	DFM-40-160-P-A-KF
170945	DFM-40-200-P-A-KF
Piston Ø 50 mm	
170946	DFM-50-25-P-A-KF
170947	DFM-50-50-P-A-KF
170948	DFM-50-80-P-A-KF
170949	DFM-50-100-P-A-KF
170950	DFM-50-125-P-A-KF
170951	DFM-50-160-P-A-KF
170952	DFM-50-200-P-A-KF

Guided drives DFM

Accessories

1

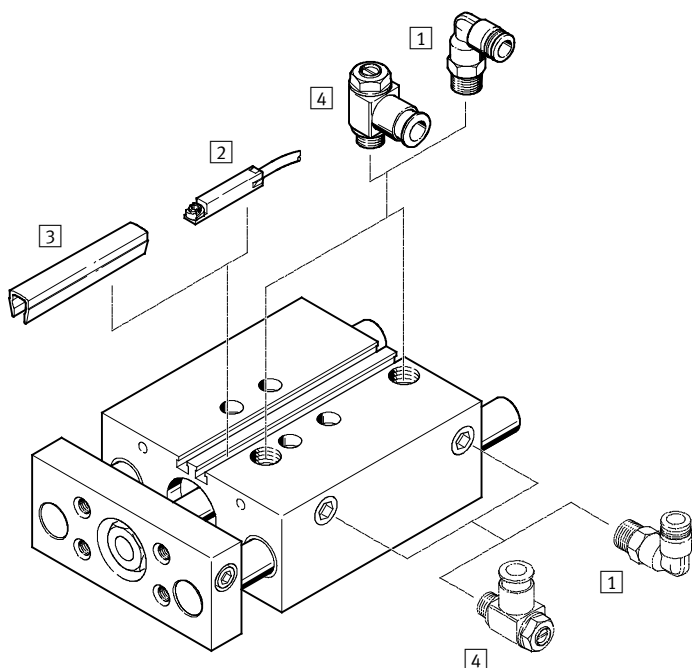

		→ Page/online
1	Push-in fitting QS	908
2	Proximity sensor SME-/SMT-8	274
3	Slot cover ABP-5-S	274
4	One-way flow control valve GRLA	275
-	Centring sleeve ZBH	275
-	Connecting cable NEBU	275
-	Drive/drive connections	adapter kit

Accessories – Ordering data

	For Ø		Part No.	Type	
2 Proximity sensor for T-slot, magneto-resistive – N/O contact Technical data → 737					
		PNP, cable	★ 574335	SMT-8M-A-PS-24V-E-2,5-OE	
		PNP, plug	★ 574334	SMT-8M-A-PS-24V-E-0,3-M8D	
		PNP, plug	★ 574337	SMT-8M-A-PS-24V-E-0,3-M12	
		NPN, cable	★ 574338	SMT-8M-A-NS-24V-E-2,5-OE	
		NPN, plug	★ 574339	SMT-8M-A-NS-24V-E-0,3-M8D	
Magneto-resistive – N/C contact Technical data → 737					
		PNP, cable	★ 574340	SMT-8M-A-PO-24V-E-7,5-OE	
Magnetic reed – N/O contact Technical data → 732					
		Cable	★ 543862	SME-8M-DS-24V-K-2,5-OE	
		Cable	★ 543863	SME-8M-DS-24V-K-5,0-OE	
		Cable	★ 543872	SME-8M-ZS-24V-K-2,5-OE	
		Plug	★ 543861	SME-8M-DS-24V-K-0,3-M8D	
Technical data → 734					
		Cable	★ 150855	SME-8-K-LED-24	
		Plug	150857	SME-8-S-LED-24	
Magnetic reed – N/C contact Technical data → 734					
		Cable	160251	SME-8-O-K-LED-24	
3 Slot cover¹⁾					
			151680	ABP-5-S	

1) Packaging unit 2x 0.5 m.

Accessories – Ordering data





Function	For Ø	Connection		Part No.	Type
		Thread	O.D.		
4 One-way flow control valve with slotted head screw, metal²⁾ for exhaust air flow control Technical data → 609					
	12, 16, 20	M5	3	★ 193137	GRLA-M5-QS-3-D
	25	G $\frac{1}{8}$	3	★ 193142	GRLA- $\frac{1}{8}$ -QS-3-D
	32	G $\frac{1}{8}$	4	★ 193143	GRLA- $\frac{1}{8}$ -QS-4-D
	40	G $\frac{1}{8}$	6	★ 193144	GRLA- $\frac{1}{8}$ -QS-6-D
	50, 63	G $\frac{1}{4}$	6	★ 193146	GRLA- $\frac{1}{4}$ -QS-6-D
	80, 100	G $\frac{3}{8}$	8	★ 193145	GRLA- $\frac{3}{8}$ -QS-8-D

2) The recommended flow control valves are based on a tubing length to the valve of 1 m. For deviations of $\pm 50\%$, flow control valves with a bigger or smaller flow rate must be selected to guarantee the optimum flow control function and cylinder speed.

Centring sleeves¹⁾

	For Ø	For housing		For yoke plate	
		Part No.	Type	Part No.	Type
	12	150928	ZBH-5	150928	ZBH-5
		150927	ZBH-9		
	16	150927	ZBH-9	150928	ZBH-5
		186717	ZBH-7		
	20	150927	ZBH-9	150927	ZBH-9
		186717	ZBH-7		
	25	150927	ZBH-9	150927	ZBH-9
		186717	ZBH-7		
	32	150927	ZBH-9	150927	ZBH-9
		189653	ZBH-12		
	40	150927	ZBH-9	150927	ZBH-9
		189653	ZBH-12		
	50	189653	ZBH-12	189653	ZBH-12
63	189653	ZBH-12	189653	ZBH-12	
80	189653	ZBH-12	189653	ZBH-12	
100	191409	ZBH-15	191409	ZBH-15	

1) 2 included in the scope of delivery in each case. Supplied in packs of 10 for repeat orders.

	For Ø		Part No.	Type
Connecting cable, straight socket Technical data → 949				
	2.5 m	★	541333	NEBU-M8G3-K-2.5-LE3
	5.0 m	★	541334	NEBU-M8G3-K-5-LE3
	2.5 m		541363	NEBU-M12G5-K-2.5-LE3
	5.0 m		541364	NEBU-M12G5-K-5-LE3
Angled socket Technical data → 949				
	2.5 m	★	541338	NEBU-M8W3-K-2.5-LE3
	5.0 m	★	541341	NEBU-M8W3-K-5-LE3
	2.5 m		541367	NEBU-M12W5-K-2.5-LE3
	5.0 m		541370	NEBU-M12W5-K-5-LE3

Guided drives DFM

Dimensions

1 Ø 12 ... 16 mm

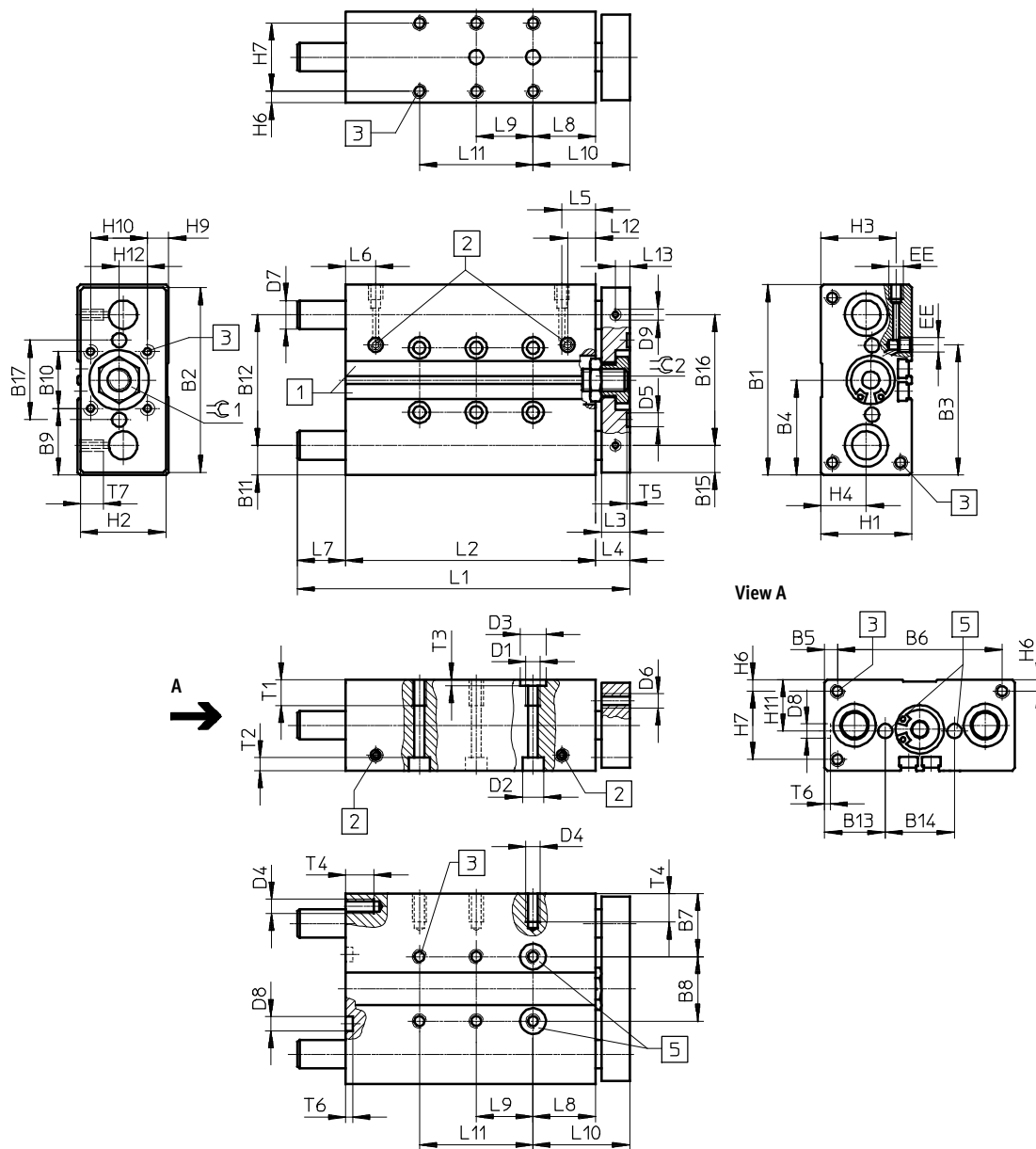

- 1 Mounting slot for proximity sensor SME/SMT-8
- 2 Supply port options on side or top
- 3 Mounting thread
- 5 Tolerance between the centring holes ±0.02 mm

Note
 If the guide rods project beyond the contour of the housing in the retracted position (→ dimension L7) when the unit is mounted on its end cap, an appropriate recess must be provided in the mounting surface so that the guide rods can move freely.

Dimensions

Download CAD data → www.festo.com

1

∅	B1	B2	B3	B4	B5	B6	B7	B8	B9	B10	B11	B12	B13	B14	B15	B16	B17	D1	D2	D3
[mm]																			∅	∅
12	60	58	42.4	30	4.5	51	20.5	19	20	20	9.5	41	19.5	21	8.5	41	25	M5	8	9
16	67	65	45.9	33.5	4.5	58	22	23	23.5	20	10.5	46	21.3	24.4	–	–	28	M5	7.5	9

∅	D4	D5 ∅ H7	D6	D7 ∅		D8 ∅ H7	D9	EE	H1	H2	H3	H4	H6	H7	H9	H10	H11	H12
				GF	KF													
12	M4	5	M4	10 _{h8}	8 _{h6}	5	M4	M5	28	26	24	14	4	20	4	20	14	10
16	M5	5	M5	12 _{h8}	10 _{h6}	5	–	M5	32	30	26.5	16	4	24	7.4	20	16	10

∅	Stroke [mm]	L1	L2	L3	L4	L5	L6	L7	L8	L9	L10	L11
12	10	59	46	10	13	11.4	9.5	–	21	–	34	–
	20	69	56									–
	25	74	61									20
	30	79	66									20
	40	95	76									20
	50	105	86									40
	80	135	116									40
	100	155	136									40
16	10	60	48	10	12	11.9	10.6	–	22	–	34	–
	20	70	58									–
	25	75	63									20
	30	80	68									20
	40	107	78									20
	50	117	88									40
	80	147	118									40
	100	167	138									40

∅	Stroke [mm]	L12	L13	T1	T2	T3	T4	T5	T6	T7	≈C1	≈C2
12	10	11.4	5	9	9.4	2.1	8	1.2	1	8	10	10
	20											
	25											
	30											
	40											
	50											
	80											
16	10	11.9	–	9	4.6	2.1	10	1.2	1	–	14	14
	20											
	25											
	30											
	40											
	50											
	80											

Guided drives DFM

Dimensions

1 Ø 20 ... 25 mm

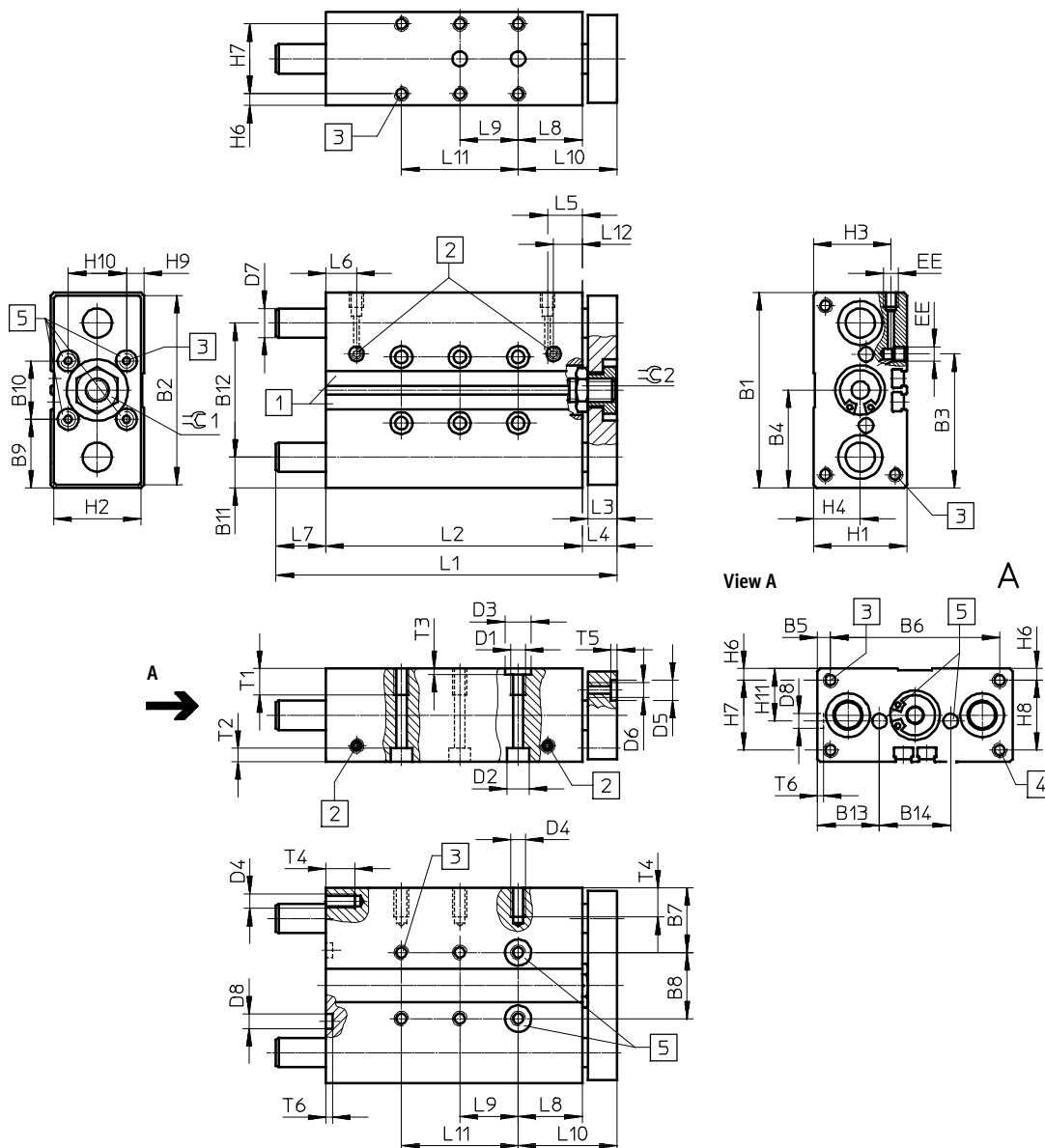

- 1 Mounting slot for proximity sensor SME-/SMT-8
- 2 Supply port options on side or top
- 3 Mounting thread
- 4 Mounting thread (not with Ø20)
- 5 Tolerance between the centring holes ±0.02 mm

Note
 If the guide rods project beyond the contour of the housing in the retracted position (→ dimension L7) when the unit is mounted on its end cap, an appropriate recess must be provided in the mounting surface so that the guide rods can move freely.

Dimensions

Download CAD data → www.festo.com

1

∅ [mm]	B1	B2	B3	B4	B5	B6	B7	B8	B9	B10	B11	B12	B13	B14	D1	D2 ∅	D3 ∅ H7	D4
20	83	81	53.6	41.5	6.5	70	26.5	30	26.5	30	12.5	58	26	31	M6	9	9	M5
25	95	93	70	47.5	15.5	64	30	35	27.5	40	13.5	68	29	37	M6	9	9	M6

∅ [mm]	D5 ∅ H7	D6	D7 ∅		D8 ∅ H7	EE	H1	H2	H3	H4	H6	H7	H8	H9	H10	H11
			GF	KF												
20	9	M5	14 _{h8}	12 _{h6}	7	M5	36	34	29.5	17	4.5	27	–	7	20	18
25	9	M6	16 _{h8}	14 _{h6}	7	G ¹ / ₈	44	42	34.8	19	4.5	35	35	12	20	22

∅ [mm]	Stroke [mm]	L1	L2	L3	L4	L5	L6	L7	L8	L9	L10 ±0.1
20	20	75	61	12	14	14	10.5	–	26	–	40
	25	80	66					20			
	30	85	71					20			
	40	121	81					20			
	50	131	91					40			
	80	161	121					40			
	100	181	141					40			
25	20	93	65.6	12	14	17.5	9.5	13.4	26	–	40
	25	98	70.6					20			
	30	103	75.6					20			
	40	123	85.6					20			
	50	133	95.6					40			
	80	163	125.6					40			
	100	183	145.6					40			

∅ [mm]	Stroke [mm]	L11	L12	T1	T2	T3	T4	T5	T6	≈C1	≈C2
20	20	–	14	12	5.7	2.1	10	2.1	1.6	17	17
	25	–									
	30	–									
	40	–									
	50	–									
	80	–									
	100	80									
25	20	–	15	14	5.7	2.1	12	2.1	1.6	17	17
	25	–									
	30	–									
	40	–									
	50	–									
	80	–									
	100	80									

Guided drives DFM

Dimensions

1 Ø 32 ... 63 mm

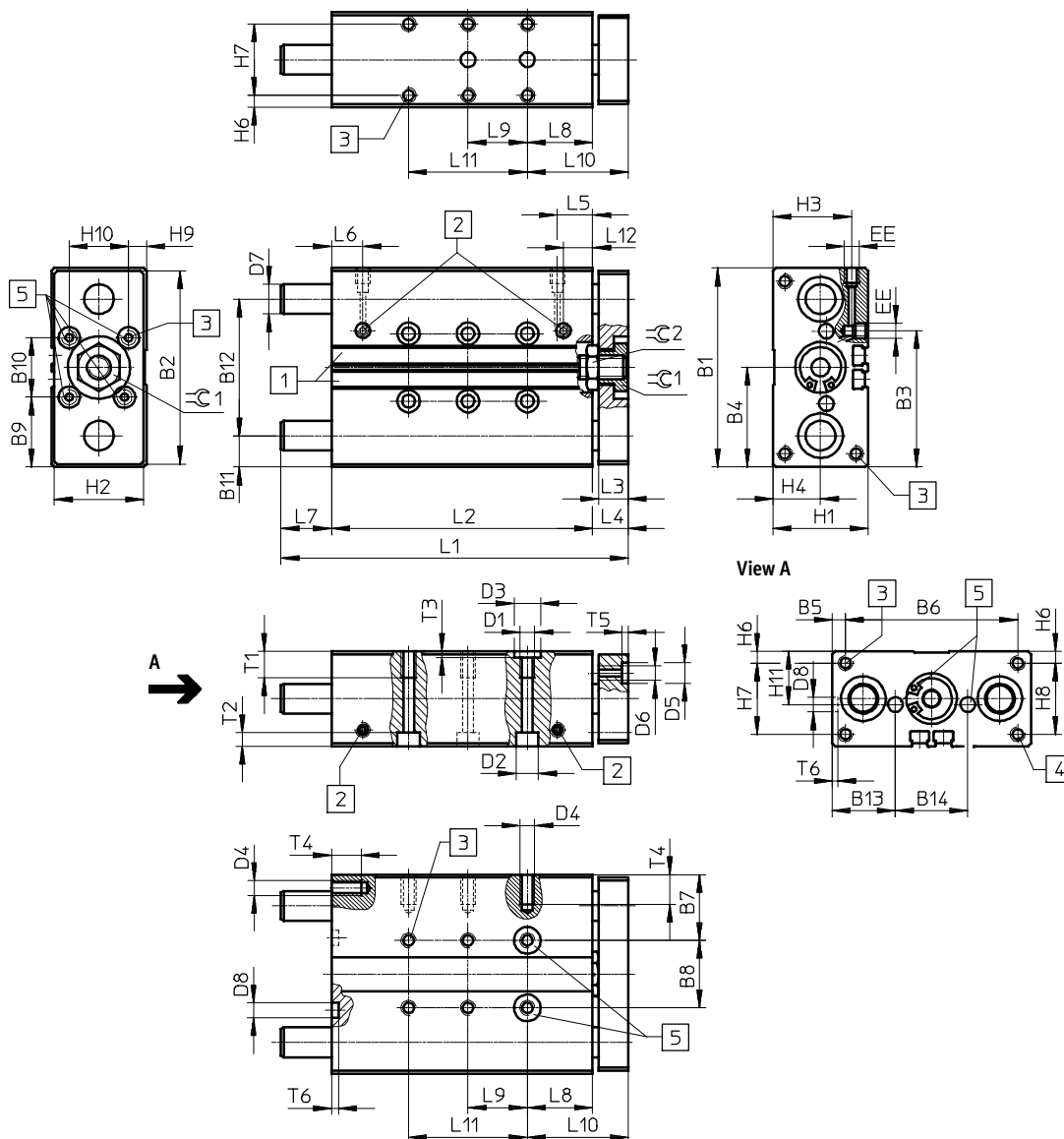

- 1 Mounting slot for proximity sensor SME-/SMT-8
- 2 Supply port options on side or top
- 3 Mounting thread
- 4 Tolerance between the centring holes ±0.02 mm
- 5 Tolerance between the centring holes ±0.02 mm

Note
 Since the guide rods project beyond the contour of the housing in the retracted position (→ dimension L7) when the unit is mounted on its end cap, an appropriate recess must be provided in the mounting surface so that the guide rods can move freely.

Dimensions

Download CAD data → www.festo.com

∅ [mm]	B1	B2	B3	B4	B5	B6	B7	B8	B9	B10	B11	B12	B13	B14	D1	D2 ∅	D3 ∅ H7	D4
32	110	108	81	55	20	70	33.5	43	35	40	16	78	32.5	45	M8	11	12	M6
40	120	118	94	60	15	90	34.5	51	35	50	16	88	32.5	55	M8	11	12	M8
50	148	146	116.5	74	19	110	42	64	44	60	19	110	40	68	M8	11	12	M8
63	162	160	139	81	9	144	41	80	41	80	18.4	125	39.5	83	M10	15	12	M10

∅ [mm]	D5 ∅ H7	D6	D7 ∅		D8 ∅ H7	EE	H1	H2	H3	H4	H6	H7	H8	H9	H10	H11
			GF	KF												
32	9	M6	20 _{h8}	16 _{h6}	9	G $\frac{1}{8}$	49	47	38.5	22	6	37	37	8.5	30	24.5
40	9	M6	20 _{h8}	16 _{h6}	9	G $\frac{1}{8}$	54	52	40.5	24	6	42	42	10	30	27
50	12	M8	25 _{h8}	20 _{h6}	12	G $\frac{1}{4}$	64	62	50.5	29.5	7	50	50	12	40	32
63	12	M8	25 _{h8}	20 _{h6}	12	G $\frac{1}{4}$	78	76	55	32	9	60	60	19	40	39

∅ [mm]	Stroke [mm]	L1	L2	L3	L4	L5	L6	L7	L8	L9	L10 ±0.1	L11	L12	T1	T2	T3	T4	T5	T6	≈C1	≈C2
25	106	73	17	20	80																
30	111	78	17	20	80																
40	121	88	17	20	80																
50	131	98	17	40	120																
80	179	128	35	40	160																
100	199	148	35	40	160																
125	244	173	55	40	160																
160	279	208	55	40	160																
200	319	248	55	40	160																
40	25	106	76	14	16	17.8	13.1	14	29	45	17.8	15	6.8	2.6	16	2.1	2.1	17	22		
50	131	101	14																	40	80
80	179	131	32																	40	80
100	199	151	32																	40	120
125	244	176	52																	40	160
160	279	211	52																	40	160
200	319	251	52	40	160																
50	25	118	77	16	18	17.8	14.2	23	32	50	17.8	15	6.8	2.6	16	2.6	2.6	19	24		
50	143	102	23																	40	80
80	194	132	44																	40	80
100	214	152	44																	40	120
125	259	177	64																	40	160
160	294	212	64																	40	160
200	334	252	64																	40	160
63	25	118	83	16	18	18.5	14.8	17	32	50	18.5	20	9	2.6	20	2.6	2.6	19	24		
50	143	108	17																	40	80
80	194	138	17																	40	80
100	214	158	38																	40	120
125	259	183	38																	40	160
160	294	218	58																	40	160
200	334	258	58																	40	200

Guided drives DFM

Dimensions

1 Ø 80 ... 100 mm

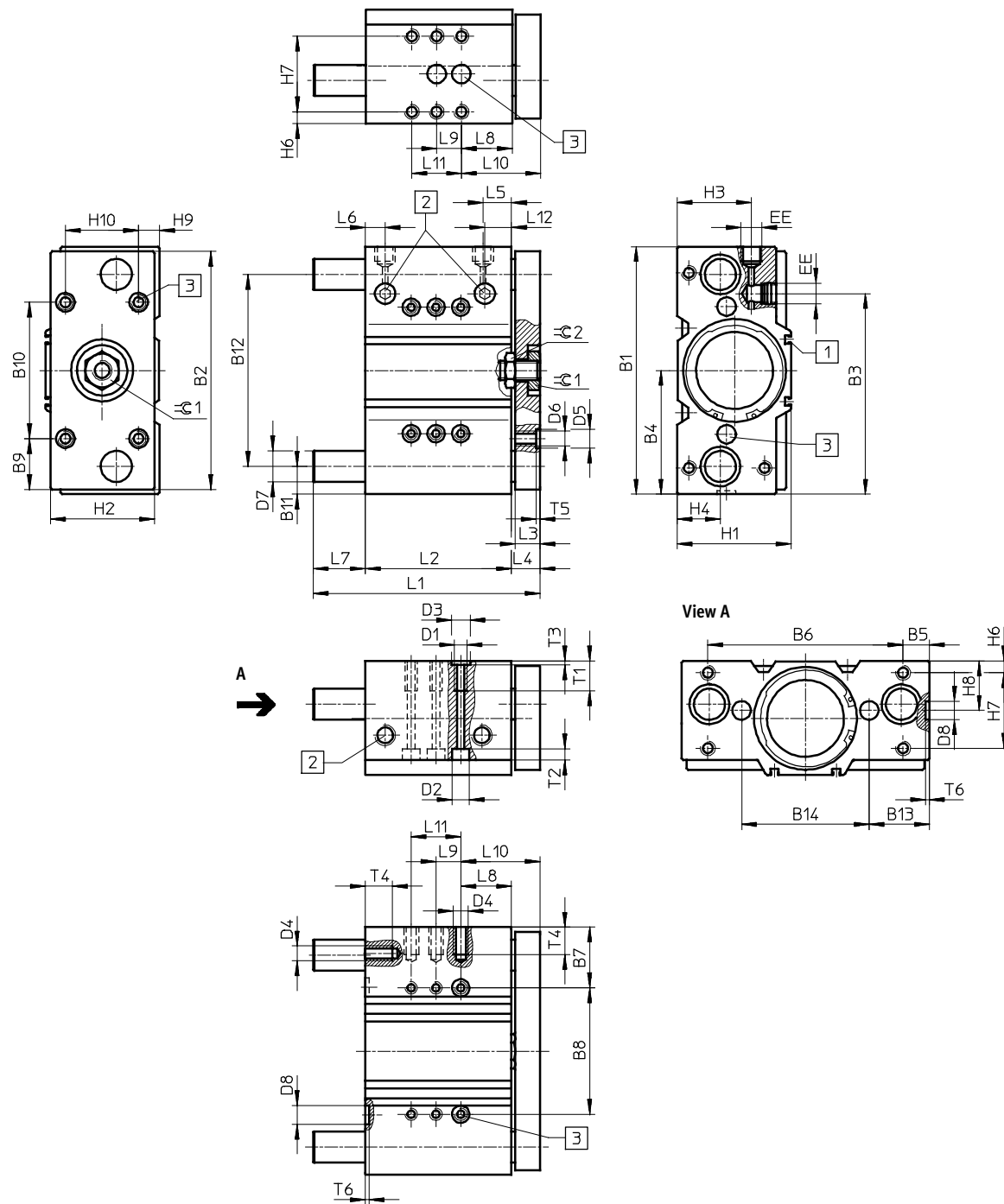

1 Mounting slot for proximity sensor SME-/SMT-8

2 Supply port options on side or top

3 Tolerance between the centring holes ±0.02 mm

Note

Since the guide rods project beyond the contour of the housing in the retracted position (→ dimension L7) when the unit is mounted on its end cap, an

appropriate recess must be provided in the mounting surface so that the guide rods can move freely.

Dimensions

Download CAD data → www.festo.com

1

∅	B1	B2	B3	B4	B5	B6	B7	B8	B9	B10	B11	B12	B13	B14	D1	D2 ∅	D3 ∅ H7
[mm]																	
80	200	192	162.5	100	21.5	157	48.5	103	41	110	22.5	155	48.5	103	M10	15	12
100	240	232	201	120	21	198	54	132	56	120	26	188	57	126	M12	18	15

∅	D4	D5 ∅ H7	D6	D7 ∅		D8 ∅ H7	EE	H1	H2	H3	H4	H6	H7	H8	H9	H10
				GF	KF											
[mm]																
80	M10	12	M10	30 _{h8}	25 _{h6}	12	G ³ / ₈	92	84	61	35	9	62	40	16	60
100	M12	15	M12	35 _{h8}	30 _{h6}	15	G ³ / ₈	112	104	66	39.5	10	68	44	16	80

∅	Stroke [mm]	L1	L2	L3	L4	L5	L6	L7	L8	L9	L10 ±0.1	L11	L12	T1	T2	T3	T4	T5	T6	≈C1	≈C2
80	25	137	93	20	23	23	16	21	41	20	64	-	23	20	9	2.6	20	2.6	2.6	27	30
	50	183	118					42		40		-									
	80	243	148					72		40		-									
	100	263	168					72		40		80									
	125	288	193					72		40		80									
	160	323	228					72		40		120									
	200	363	268					72		40		160									
100	25	150	109	20	23	29	20	18	13	40	36	-	29	25	11	3.1	24	3.1	3.1	32	30
	50	197	134					40		40		80									
	80	257	164					70		40		80									
	100	277	184					70		40		120									
	125	302	209					70		40		160									
	160	337	244					70		40		160									
	200	377	284					70		40		200									

2 Servopneumatic positioning systems

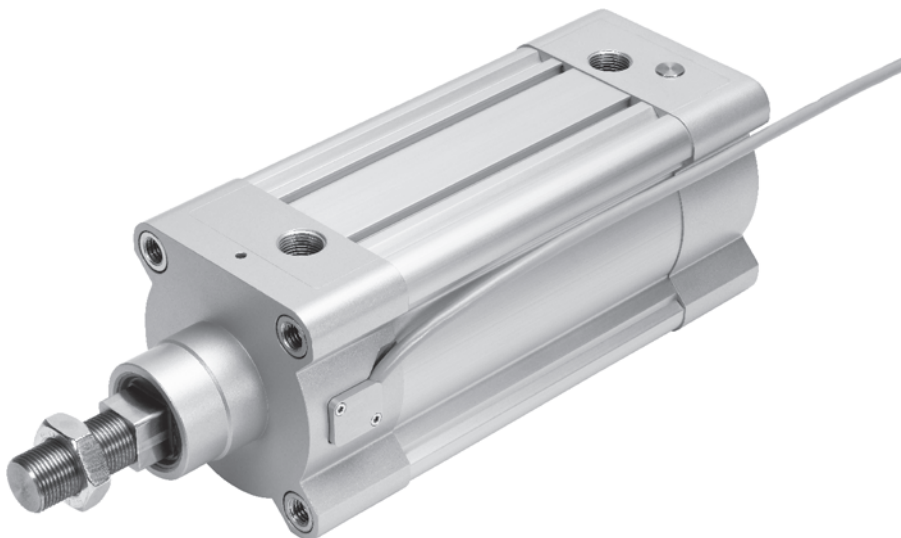





Software tool

2

Soft Stop		Soft Stop virtually makes the impossible possible. Travel times are reduced by as much as 30% for pneumatic drives and vibration is also greatly reduced. The selection program performs all of the necessary calculations.	This tool can be found <ul style="list-style-type: none"> • in the electronic catalogue via the blue icons in the product tree underneath the search field, or • on the website under Support in the Engineering software area, or • on the DVD under Selection and sizing.
------------------	---	---	--

Linear drives with displacement encoder

Type				
Piston diameter	100 mm, 80 mm	32 mm, 40 mm, 50 mm, 63 mm	25 mm, 32 mm, 40 mm	18 mm, 25 mm, 32 mm, 40 mm, 63 mm
Theoretical force at 6 bar, advancing	3,016 ... 4,712 N	415 ... 1,870 N	153 ... 483 N	153 ... 1,870 N
Max. load, horizontal	300 ... 450 kg	45 ... 180 kg	100 ... 2,000 mm	1 ... 180 kg
Max. load, vertical	100 ... 150 kg	15 ... 60 kg		1 ... 60 kg
Stroke	10 ... 2,000 mm	10 ... 2,000 mm		100 ... 2,000 mm
Description	<ul style="list-style-type: none"> • Standard cylinder to ISO 15552 • With contactless displacement encoder • Can be used as a measuring cylinder • With axis controller CPX-CMAX, SPC200 suitable for positioning • With end-position controller CPX-CMPX, SPC11 suitable for end-position control • Piston rod variants • Fixed cushioning 	<ul style="list-style-type: none"> • Standard cylinder to ISO 15552 • With integrated displacement encoder for relative analogue, contactless measuring • Suitable for servopneumatic applications with axis controller CPX-CMAX, SPC200, end-position controller CPX-CMPX, SPC11 and measuring module CPX-CMIX • Piston rod variants • Male piston rod thread 	<ul style="list-style-type: none"> • Without guide • With contactless displacement encoder • Based on linear drive DGC-K • Supply ports on end face • Can be used as a measuring cylinder • With axis controller CPX-CMAX, SPC200 suitable for positioning • With end-position controller CPX-CMPX, SPC11 suitable for end-position control 	<ul style="list-style-type: none"> • With displacement encoder for absolute and contactless measuring • Suitable for servopneumatic applications with axis controller CPX-CMAX, SPC200, end-position controller CPX-CMPX, SPC11 and measuring module CPX-CMIX • With guide • Supply ports optionally on end face or front
→ Page/online	ddpc	dnci	ddli	dgci





Linear drives with displacement encoder

Type	
Piston diameter	25 mm, 32 mm, 40 mm, 50 mm, 63 mm
Theoretical force at 6 bar, advancing	295 ... 1,870 N
Max. load, horizontal	2 ... 180 kg
Max. load, vertical	10 ... 60 kg
Stroke	225 ... 2,000 mm
Description	<ul style="list-style-type: none"> • With integrated displacement encoder for absolute and contactless measuring • Suitable for servopneumatic applications with axis controller CPX-CMAX, SPC200, end-position controller CPX-CMPX, SPC11 and measuring module CPX-CMIX • Available with or without guide
→ Page/online	dgpi

Swivel modules with displacement encoder

	
Type	Swivel module with angular displacement encoder DSMI-B
Piston diameter	25 mm, 40 mm, 63 mm
Torque at 6 bar	5 ... 40 Nm
Max. mass moment of inertia, horizontal	0.03 ... 0.6 kgm ²
Max. mass moment of inertia, vertical	0.03 ... 0.6 kgm ²
Swivel angle	0 ... 272°
Description	<ul style="list-style-type: none"> • Integrated rotary encoder • Suitable for servopneumatic applications with CPX-CMAX, CPX-CMPX, CPX-CMIX, SPC200 and SPC11 • With rotary vane • Compact design
→ Page/online	dsmi

Axis controllers

				
Type	Axis controller CPX-CMAX	Axis controller SPC200	End-position controller CPX-CMPX	End-position controller SPC11
No. of axis strings	1	2	1	1
Axes per string	1	2	1	1
Description	<ul style="list-style-type: none"> • Axis controller as CPX module, supports pneumatic drives with piston rod, rodless drives and semi-rotary drives • Force and position control • Use with all fieldbus/Ethernet and CEC controllers available in CPX • Easy commissioning thanks to auto identification function • Rapid commissioning and comprehensive diagnostics with the parameterisation software FCT 	<ul style="list-style-type: none"> • Position controller in modular design with I/O or fieldbus interface • Supports pneumatic drives with piston rod, rodless drives and semi-rotary drives as well as stepper motor drives • Commissioning software: WinPISA • For dynamic positioning applications • Programming language to DIN 66025 	<ul style="list-style-type: none"> • Electronic end-position control for pneumatic drives • Soft Stop for smooth braking and quick acceleration • Use with all fieldbus/Ethernet available in CPX • Easy commissioning, Festo plug and work • Approx. 30% shorter travel times and 30% less air consumption than with comparable standard pneumatics 	<ul style="list-style-type: none"> • Quickly and smoothly into the end position with two additional intermediate positions • Electronic end-position cushioning • Quick and easy commissioning: configure, teach, done • Supports pneumatic drives with piston rod, rodless drives and semi-rotary drives
→ Page/online	cpx-cmax	spc200	cpx-cmpx	spc11

Axis controllers

	
Type	Measuring module CPX-CMIX
No. of axis strings	1
Axes per string	1
Description	<ul style="list-style-type: none"> • Movement and measurement with measuring module CPX-CMIX • Records the position and speed of a drive with displacement encoder • Standardised digital signal processing • Use with all fieldbus/Ethernet and CEC controllers available in CPX • Measurement accuracy ±0.01 ... 0.02 mm • Quick and easy commissioning
→ Page/online	cpx-cmix



Displacement encoders

Type	Displacement encoder MLO-POT-TLF	Displacement encoder MLO-POT-LWG	Displacement encoder MME-MTS-TLF
Stroke	225 ... 2,000 mm	100 ... 750 mm	225 ... 2,000 mm
Measuring principle of displacement encoder	Analogue	Analogue	Digital
Output signal	Analogue	Analogue	CAN protocol type SPC-AIF
Displacement resolution	0.01 mm	0.01 mm	0 ... 0.01 mm
Description	<ul style="list-style-type: none"> Conductive plastic potentiometer Absolute measurement with high resolution High travel speed and long service life Several mounting options on pneumatic linear drives DGPL Plug-in connections 	<ul style="list-style-type: none"> Connecting rod potentiometer Absolute measurement with high resolution Long service life High protection class Plug-in connections 	<ul style="list-style-type: none"> Measuring principle: magnetostrictive Contactless with absolute measurement High travel speed System product for servopneumatic Positioning technology and Soft Stop
→ Page/online	mlo	mlo	mme

Proportional valves

Type	Proportional directional control valve VPWP	Proportional directional control valve MPYE
Valve function	5/3-way proportional directional control valve, closed	5/3-way, closed
Pneumatic connection 1	G1/8, G1/4, G3/8	G1/8, G1/4, G3/8, M5
Operating pressure	0 ... 10 bar	0 ... 10 bar
Standard nominal flow rate	350 ... 2,000 l/min	100 ... 2,000 l/min
Description	<ul style="list-style-type: none"> Controlled piston spool valve Digital actuation Integrated pressure sensors for monitoring function and force control With auto identification Diagnostic function Integrated digital output, e.g. for a clamping/brake unit Suitable for servopneumatic applications with CPX-CMAX and CPX-CPMX 	<ul style="list-style-type: none"> Controlled piston spool valve Analogue actuation Setpoint value input as voltage signal (0 ... 10 V) Suitable for servopneumatic applications with SPC200 and SPC11
→ Page/online	vpwp	mpye

Sensor interfaces

Type	 Sensor interface CASM	 Measured-value transducer DADE	 Axis interface SPC-AIF
Diagnostic function	Display via LED	Display via LED	Display via LED
Electrical connection, displacement encoder	5-pin, 8-pin, socket, M12	8-pin, socket, M12	Cable with plug, 8-pin socket, M12, 5-pin socket, M9
Electrical connection, control interface	5-pin, M9, plug		5-pin, 7-pin, M9, socket and plug
Control interface	CAN Bus with Festo protocol, digital, without terminating resistor		CAN Bus with Festo protocol, digital, without terminating resistor
Description	<ul style="list-style-type: none"> • For actuating pneumatic positioning drives with the latest servopneumatic systems such as CPX-CMAX, CPX-CMPX and CPX-CMIX • Short cables for analogue signals, secure digitised bus transmission • Convenient plug and work concept with auto identification and comprehensive diagnostics • High protection class IP67 	<ul style="list-style-type: none"> • For standard cylinder DNCI • Converts sensor signals into voltage or current signals • Mounting via through-holes • Diagnostic display via LED 	<ul style="list-style-type: none"> • Interface for signal distribution of the control signal from the SPC200 to the drive/displacement encoder and proportional valve MPYE • Transmission of control signals to a second axis interface for a second positioning axis • High protection class IP65 • Short cables for analogue signals • Pre-assembled cables
→ Page/online	casm	dade	spc-aif

3 Electromechanical drives

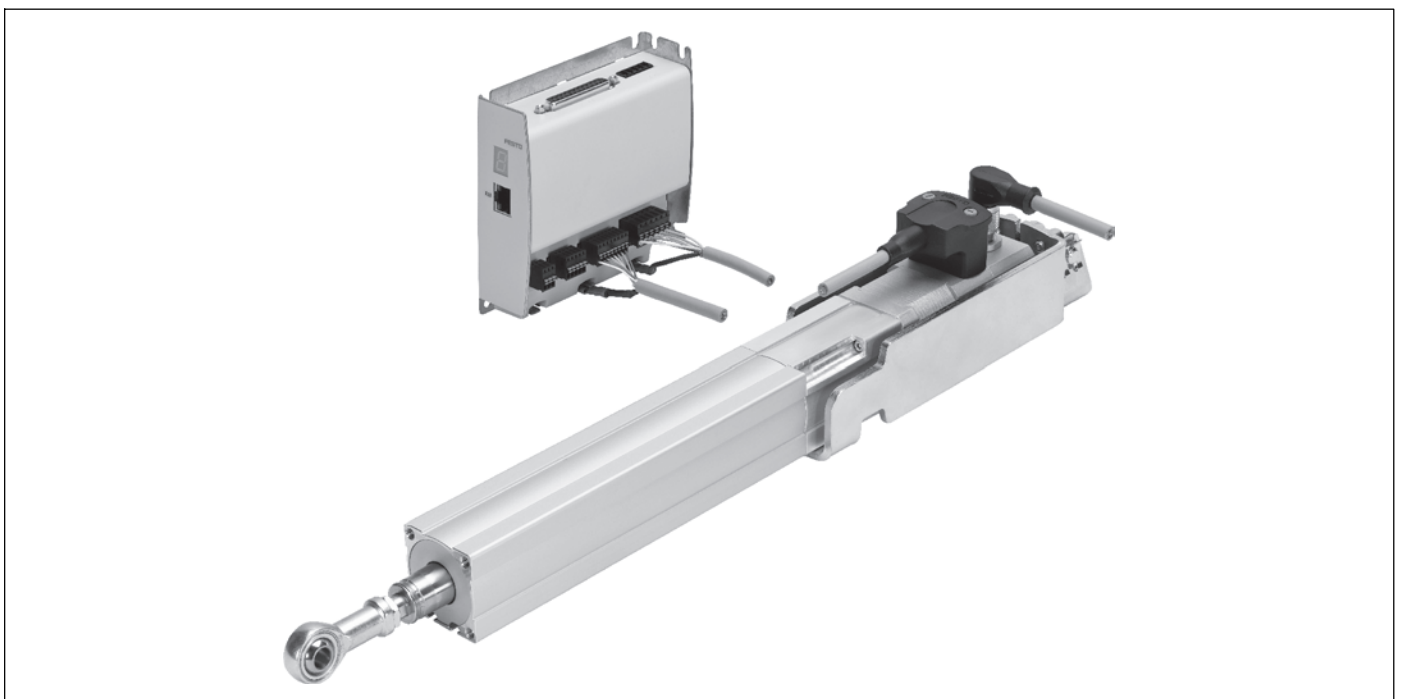





Software tool





PositioningDrives		<p>Which electromechanical linear drive best meets your needs? Enter the data for your application, such as position values, effective loads and mounting position, and the software suggests a number of solutions.</p>	<p>This tool can be found</p> <ul style="list-style-type: none"> • in the electronic catalogue via the blue icons in the product tree underneath the search field, or • on the website under Support in the Engineering software area, or • on the DVD under Selection and sizing.
--------------------------	--	--	---

3





Linear drives and slide units

Type	 Electric cylinder EPCO	 Electric cylinder ESBF	 Electric cylinder DNCE	 Spindle axis EGC-BS-KF
Size	16, 25, 40	63, 80, 100	32, 40, 63	50, 70, 80, 120, 185
Max. feed force Fx	50 ... 650 N	6,000 ... 17,000 N	300 ... 2,500 N	300 ... 3,000 N
Repetition accuracy	+/-0.02 mm	+/-0.01 mm, +/-0.015 mm	+/-0.02 +/-0.03 mm, +/-0.02 mm, +/-0.07 mm	+/-0.02 mm
Working stroke	50 ... 400 mm	100 ... 400 mm	100 ... 800 mm	50 ... 3,000 mm
Description	<ul style="list-style-type: none"> • Linear drive with permanently attached motor • With recirculating ball spindle • Available with female thread • Available with holding brake • Protection class IP40 • Compact dimensions • Extensive mounting accessories for various installation situations • Suitable for simple applications in factory automation that in the past were mostly carried out using pneumatic solutions 	<ul style="list-style-type: none"> • With spindle drive • Optional: high corrosion protection, protection class IP65, suitable for use in the food industry, piston rod extension • Wide range of accessories 	<ul style="list-style-type: none"> • Lead screw or ball screw • Standard hole pattern to ISO 15552 • Available with high corrosion protection • Available with lubrication approved for food use • Axial or parallel motor mounting • Integrated reference switch • Freely positionable • Non-rotating piston rod • Larger strokes available on request 	<ul style="list-style-type: none"> • Recirculating ball bearing guide for high loads and torques • Available with clamping unit, at one or both ends • Profile with optimised rigidity • High dynamic response and minimum vibration • Various spindle pitches • Reference switch optional • Freely positionable
→ Page/online	297	306	314	324

Linear drives and slide units





Type	 Spindle axis EGC-HD-BS	 Toothed belt axis EGC-TB-KF	 Toothed belt axis EGC-HD-TB	 Mini slide EGSL
Size	125, 160, 220	50, 70, 80, 120, 185	125, 160, 220	35, 45, 55, 75
Max. feed force Fx	300 ... 1,300 N	50 ... 2,500 N	450 ... 1,800 N	75 ... 450 N
Repetition accuracy	+/-0.02 mm	+/-0.08 mm, +/-0.1 mm	+/-0.08 mm, +/-0.1 mm	+/-0.015 mm
Working stroke	50 ... 2,400 mm	50 ... 8,500 mm	50 ... 5,000 mm	50 ... 300 mm
Description	<ul style="list-style-type: none"> • With heavy-duty guide • With integrated ball screw • For maximum loads and torques, high feed forces and speeds and long service life • Precise and resilient duo rail guide • Excellent price/performance ratio • Flexible motor mounting 	<ul style="list-style-type: none"> • Recirculating ball bearing guide for high loads and torques • Available with clamping unit, at one or both ends • Profile with optimised rigidity • High dynamic response and minimum vibration • Small toothed disc diameter • Reference switch optional • Freely positionable 	<ul style="list-style-type: none"> • With heavy-duty guide • For maximum loads and torques, high feed forces and speeds and long service life • Precise and resilient duo rail guide • Excellent price/performance ratio • Flexible motor mounting 	<ul style="list-style-type: none"> • Very high rated slide loads, ideal for vertical applications such as press-fitting or joining • Reliable: the completely closed spindle stops dirt or stray small parts getting into the guide area • Flexible: motor can be attached laterally or axially, in this case turned by 4 x 90° • Matching software tools in the FCT software package from Festo
→ Page/online	334	344	354	364

Linear drives and slide units



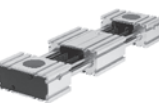

Type	 Mini slide SLTE	 Electric slide EGSK	 Electric slide EGSP	 Toothed belt axis ELGA-TB-G
Size	10, 16	15, 20, 26, 33, 46	20, 26, 33, 46	70, 80, 120
Max. feed force F _x		19 ... 392 N	69 ... 466 N	350 ... 1,300 N
Repetition accuracy	+/-100,000 µm	+/-0.003, +/-0.004 mm, +/-0.003 +/-0.01 mm, +/-0.01 mm	+/-0.003, +/-0.01 mm	+/-0.08 mm
Working stroke	50 ... 150 mm	25 ... 840 mm	25 ... 840 mm	50 ... 8,500 mm
Description	<ul style="list-style-type: none"> • Electromechanical linear axis with lead screw spindle • With DC servo motor • Easy actuation via I/O interface, PROFIBUS, CANopen, DeviceNet • Precise and rigid guide • Freely positionable • Fast positioning times 	<ul style="list-style-type: none"> • Electromechanical linear axis with recirculating ball bearing spindle • Recirculating ball bearing guide and ball screw without caged ball bearings • Standardised mounting interfaces • Compact design • High rigidity • Long service life 	<ul style="list-style-type: none"> • Electromechanical linear axis with recirculating ball bearing spindle • Recirculating ball bearing guide with caged ball bearings • Size 33, 46 features a ball screw with caged ball bearings • Low-maintenance • Uniform operating behaviour with very low noise levels • Standardised mounting interfaces • Compact design • High rigidity • Long service life 	<ul style="list-style-type: none"> • Integrated plain-bearing guide • For small and medium loads • Low guide backlash • Actuator for external guides • Speeds up to 5 m/s with high acceleration up to 50 m/s² • Flexible motor mounting
→ Page/online	slte	egsk	egsp	375

3

Linear drives and slide units

Type	 Toothed belt axis ELGA-TB-RF	 Toothed belt axis ELGG	 Toothed belt axis ELGR	 Cantilever axis EGSA
Size	70, 80, 120	35, 45, 55	35, 45, 55	50, 60
Max. feed force F _x	350 ... 1,300 N	50 ... 350 N	50 ... 350 N	100 ... 200 N
Repetition accuracy	+/-0.08 mm	+/-0.1 mm	+/-0.1 mm	+/-0.01 mm
Working stroke	50 ... 7,400 mm	50 ... 1,200 mm	50 ... 1,500 mm	100 ... 300 mm
Description	<ul style="list-style-type: none"> • Integrated roller bearing guide • High speeds up to 10 m/s with high acceleration up to 50 m/s² • Guide backlash = 0 mm • Very good operating behaviour under torque load • Sturdy alternative to the recirculating ball bearing guide • Actuator for external guides, especially at high speeds 	<ul style="list-style-type: none"> • For universal use with opposing movement • The different guide variants, the optional long slide and the central support enable solutions that are technically appropriate, reliable and at the same time economical • Long service life of over 2,500 km per slide • Easy and reliable sizing with PositioningDrives • Fast and user-friendly commissioning with the Festo Configuration Tool (FCT) 	<ul style="list-style-type: none"> • Optimum price/performance ratio • Ready-to-install unit for quick and easy design • High reliability thanks to tested service life of 5,000 km • Motor can be mounted on any one of 4 sides • With plain or recirculating ball bearing guide • Kit for easy and space-saving end-position sensing • Quick commissioning following easy sizing using the PositioningDrives software as well as predefined parameter sets in the parameterisation software FCT 	<ul style="list-style-type: none"> • Electromechanical cantilever axis with recirculating ball bearing spindle • High rigidity • Maximum precision • High dynamic response • Freely positionable • Integrated reference switch
→ Page/online	elga	elgg	384	egsa

Linear drives and slide units

Type	 Cantilever axis DGEA-ZR	 Toothed belt axis DGE-ZR, DGE-ZR-KF, DGE-ZR-HD	 Linear drive DGE-ZR-RF	 Spindle axis DGE-SP
Size	18, 25, 40	8, 12, 18, 25, 40, 63	25, 40, 63	18, 25, 40, 63
Max. feed force F _x	230 ... 1,000 N	15 ... 1,500 N	260... 1,500 N	140 ... 1,600 N
Repetition accuracy	+/-0.05 mm	+/-0.08 mm, +/-0.1 mm	+/-0.1 mm	+/-0.02 mm
Working stroke	1 ... 1,000 mm	1 ... 4,500 mm	1 ... 5,000 mm	100 ... 2,000 mm
Description	<ul style="list-style-type: none"> • Toothed belt drive with recirculating ball bearing guide • Dynamic cantilever operation • Stationary drive head • Reference switch optional • Freely positionable 	<ul style="list-style-type: none"> • Electromechanical axis with toothed belt DGE-ZR: without guide; DGE-ZR-KF: with recirculating ball bearing guide; DGE-ZRHD: with heavy-duty guide, recirculating ball bearing guide • Highly adaptable thanks to wide choice of mounting and attachment options • Wide range of options for mounting on drives • Comprehensive range of mounting accessories for multi-axis combinations • Optional protected version 	<ul style="list-style-type: none"> • Electromechanical axis with toothed belt and internal roller bearing guide • High speeds possible • Highly adaptable thanks to wide choice of mounting and attachment options • Wide range of options for mounting on drives • Comprehensive range of mounting accessories for multi-axis combinations 	<ul style="list-style-type: none"> • Without guide, recirculating ball bearing guide or heavy-duty guide • Optional protected version • Compact dimensions • Reference switch optional • Freely positionable
→ Page/online	dgea	dge-zr	dge-zr	dge-sp

Linear drives and slide units

Type	 Positioning axis DMES
Size	18, 25, 40, 63
Max. feed force F _x	240 ... 3,000 N
Repetition accuracy	+/-0.05 mm, +/-0.07 mm
Working stroke	50 ... 1,800 mm
Description	<ul style="list-style-type: none"> • Mechanical linear drive • Without guide, plain guide or recirculating ball bearing guide • High mechanical torques • High feed forces of up to 3,000 N • Compact dimensions • Reference switch optional • Freely positionable
→ Page/online	dmes

Semi-rotary drives





Type	 Rotary module ERMB
Size	20, 25, 32
Max. driving torque	0.7 ... 8.5 Nm
Max. input speed	900 ... 1,350 rpm
Rotation angle	Infinite
Description	<ul style="list-style-type: none"> • Electromechanical rotary module with toothed belt • Compact design • Mounting interfaces on all sides • Stable arrangement of the output shaft bearings • Unlimited and flexible rotation angle
→ Page/online	389

Electric handling modules

	
Type	Rotary/lifting module EHMB
Size	20, 25, 32
Max. driving torque	0.7 ... 6.7 Nm
Max. input speed	900 ... 1,350 rpm
Rotation angle	Infinite
Description	<ul style="list-style-type: none"> • Complete module with combined and configurable rotary/lifting movement • Dynamic, flexible, economical thanks to the modular drive concept for the linear movement • Hollow axis with large internal diameter makes laying power supply lines easy, convenient and safe • Extremely short positioning times thanks to high dynamic response during rotation, e.g. 0.25 s when swivelling a 1 kg load by 180°
→ Page/online	396

3

Direct drives

				
Type	Short-stroke cylinder ADNE-LAS	Guided drive DFME-LAS	Electric cylinder DNCE-LAS	Linear drive ELGL-LAS
Size	32, 40	32, 40	32, 40	30, 64, 120
Max. feed force Fx	8 ... 55 N	94 ... 202 N	93.7 ... 202 N	56 ... 475 N
Repetition accuracy	+/-0.01 mm	+/-0.015 mm	+/-0.02, +/-0.03 mm, +/-0.02 mm, +/-0.07 mm	+/-0.01 mm
Working stroke	15 ... 45 mm	100 ... 400 mm	100 ... 400 mm	1 ... 5,750 mm
Description	<ul style="list-style-type: none"> • Electric short-stroke cylinder with integrated linear motor • Highly dynamic movement between two end positions • Electronic end-position cushioning • Easy commissioning, Festo plug and work • Also for harsh ambient conditions 	<ul style="list-style-type: none"> • Recirculating ball bearing guide • Consisting of freely positionable linear motor, integrated displacement encoder and reference switch • Enables positioning with very high dynamic response for small loads • Long service life and maintenance-free operation • Easy actuation via I/O interface, PROFIBUS, CANopen including interpolated position mode, DeviceNet • Configuration and commissioning with the parameterisation software FCT • Festo plug and work for smooth logistics and assembly 	<ul style="list-style-type: none"> • Linear motor axis with piston rod • Consisting of freely positionable linear motor, integrated displacement encoder, reference switch and plain bearings • Positioning with very high dynamic response for small loads • Easy actuation via I/O interface, PROFIBUS, CANopen including interpolated position mode, DeviceNet • Festo plug and work for clear logistics and rapid assembly • Configuration and commissioning with the parameterisation software FCT 	<ul style="list-style-type: none"> • Electric linear drive with linear motor, air cushion bearing and displacement encoder • Ready-to-install system offering greater flexibility, precision and dynamic response • Air cushion bearing provides high precision, high linearity and wear-free characteristics • Actuation via motor controller CMMP-AS
→ Page/online	adne	dfme	dnce	elgl

Linear guides

Type	Guide unit EAGF	Passive guide axis ELFR	Passive guide axis EGC-FA	Passive guide axis FDG-ZR-RF
Size	63, 80, 100	35, 45, 55	70, 80, 120, 185	25, 40, 63
Stroke	1 ... 500 mm	50 ... 1,500 mm	50 ... 8,500 mm	1 ... 5,000 mm
Guide	Recirculating ball bearing guide	Plain-bearing guide, recirculating ball bearing guide	Recirculating ball bearing guide	Internal roller guide
Description	<ul style="list-style-type: none"> For protecting electric cylinder ESBF against rotation at high torques High guide precision 	<ul style="list-style-type: none"> Driveless guide unit with guide and freely movable slide For supporting force and torque capacity in multi-axis applications Increased torsional resistance Reduced vibrations with dynamic loads 	<ul style="list-style-type: none"> Driveless guide unit with guide and freely movable slide For supporting force and torque capacity in multi-axis applications Increased torsional resistance Reduced vibrations with dynamic loads 	<ul style="list-style-type: none"> Driveless linear guide unit with guide and freely movable slide For supporting force and torque capacity in multi-axis applications Increased torsional resistance Reduced vibrations with dynamic loads
→ Page/online	eagf	elfr	egc	fdg

Accessories for electromechanical drives

Type	Bellows and gear coupling EAMC/EAMD	Connecting shaft KSK
Description	<ul style="list-style-type: none"> System product for positioning technology For force-locked and backlash-free transmission of small and medium torques between electric motors and axes 	<ul style="list-style-type: none"> For synchronising toothed belt axes DGE and EGC For torsion-resistant transmission of the necessary torque For slip-free transmission of the feed speed
→ Page/online	eamc	ksk

Customised components – for your specific requirements

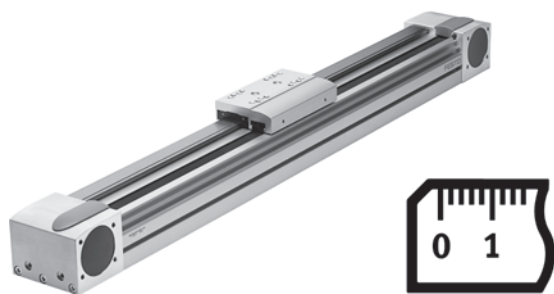

Drives with customised designs

Can't find the electromechanical drive you need in our catalogue?
We can offer you customised components that are tailored to your specific requirements – from minor product modifications to complete new product developments.

Common product modifications:

- Special strokes
- Design for special ambient conditions
- Design optimised for the fitting space
- Design with opposing carriages
- Design with absolute encoder

Many additional variants are possible. Ask your Festo sales engineer, who will be happy to help. Further information on customised components can be found on your local website at www.festo.com.



- Electromechanical linear axis with piston rod and permanently attached motor
- Recirculating ball spindle
- Axial motor mounting
- Easy commissioning and operation
- Wide range of accessories for various installation situations
- Spare parts service
- ★ Quick ordering of basic designs → 299

→ www.festo.com/catalogue/epco

Product range overview

Type/version	Size	Stroke [mm]	Feed force [N]	Spindle pitch [mm]	Product options									
					A	E	B	D	L	R	C5	DIO	N	P
EPCO														
Recirculating ball spindle	16, 25, 40	50 ... 400	50 ... 650	3 ... 12.7	■	■	■	■	■	■	■	■	■	■

Product options

- | | | | |
|----------------------------|--------------------|-----------------------------|------------------------------|
| F Female piston rod thread | A Position sensing | D Cable outlet underneath | C5 Controller type |
| E Piston rod extension | E With encoder | L Cable outlet to the left | DIO Actuation |
| | B With brake | R Cable outlet to the right | N Switching input/output NPN |
| | | | P Switching input/output PNP |

Motor mounting variants

EPCO-16

Standard

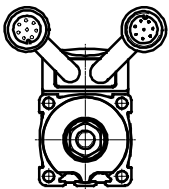

Underneath (feature D)

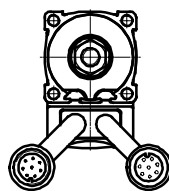

Left (feature L)

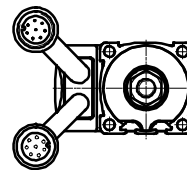

Right (feature R)

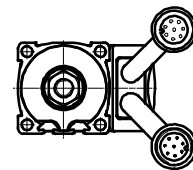

EPCO-25/-40

Standard

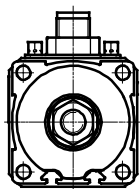

Underneath (feature D)

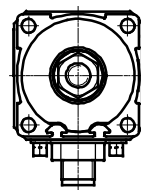

Left (feature L)

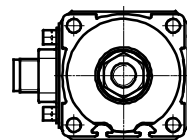

Right (feature R)

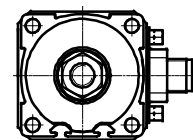

Electric cylinders EPCO, with spindle drive

FESTO

Technical data

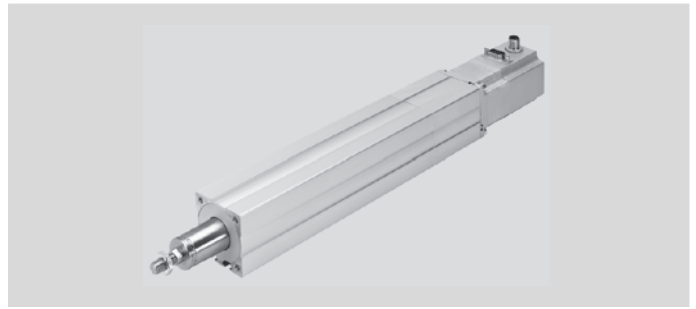
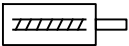

Dimensions → 305

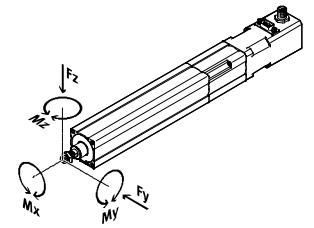

Technical data

Note

PositioningDrives
sizing software
→ www.festo.com

Size	16		25		40	
Spindle design	3P	8P	3P	10P	5P	12.7P
Working stroke [mm]	50 ... 200		50 ... 300		50 ... 400	
Spindle pitch ¹⁾ [mm/rev.]	3	8	3	10	5	12.7
Spindle diameter [mm]	8	8	10	10	12	12.7
Max. effective load						
Horizontal ²⁾ [kg]	24	8	60	20	120	40
Vertical [kg]	12	4	30	10	60	20
Max. feed force F_x [N]	125	50	350	105	650	250
Max. speed [mm/s]	125	300	150	500	180	460
Max. acceleration [m/s ²]	10					
Reversing backlash ³⁾ [mm]	≤ 0.1					
Repetition accuracy [mm]	±0.02					
Nominal voltage [V DC]	24					
Nominal current [A]	1.4		3		4.2	
Encoder						
Pulses/revolution	500					
Zero pulse	Yes					
Line driver	RS422 protocol					
Operating voltage of encoder [V]	5					
F_{xmax} (static) [N]	125	50	350	105	650	250
M_{xmax} [Nm]	0		0		0	
M_{ymax}, M_{zmax} [Nm]	0.6		1.0		3.3	

1) Nominal value varies due to component tolerances.
2) Note max. lateral force.
3) In new condition.

Mass moment of inertia

Size	16		25		40	
Spindle design	3P	8P	3P	10P	5P	12.7P
J_0 with 0 mm stroke						
EPCO-...-ST [kg mm ²]	2.28	2.29	9.33	9.40	33.25	33.75
EPCO-...-ST-B [kg mm ²]	2.97	2.98	10.63	10.70	34.55	35.05
j_S per meter stroke [kg mm ² /m]	2.53	2.65	4.87	5.78	11.66	16.70
j_L per kg effective load [kg mm ² /kg]	0.23	1.62	0.23	2.54	0.64	4.09

The mass moment of inertia J_A of the electric cylinder is calculated as follows:

$$J_A = J_0 + j_S \times \text{working stroke [m]} + j_L \times m_{\text{moving effective load [kg]}}$$

Technical data

Maximum permissible lateral forces $F_{y_{max}}$ and $F_{z_{max}}$ on the piston rod as a function of projection l

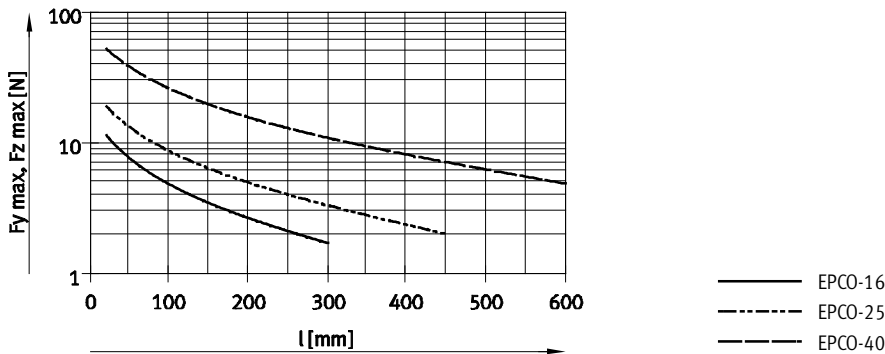

Operating conditions

Ambient temperature ⁴⁾	[°C]	0 ... +50
Protection class		IP40

4) Note operating range of proximity sensors and motors.

Materials

Bearing cap	Smooth anodised wrought aluminium alloy
Cylinder barrel	Smooth anodised wrought aluminium alloy
Piston rod	High-alloy stainless steel
Spindle	Rolled steel
Spindle nut	Steel
Drive cover	Smooth anodised wrought aluminium alloy

Ordering – Product options

Configurable product

This product and all its options can be ordered using the configurator.

The configurator can be found under Products on the DVD or
www.festo.com/catalogue/...

Enter the type code in the search field.

★ Quick ordering

EPCO-16		
Stroke [mm]	Part No.	Type
Spindle pitch 3 mm, with encoder		
50	1476415	EPCO-16-50-3P-ST-E
100	1476417	EPCO-16-100-3P-ST-E
150	1476419	EPCO-16-150-3P-ST-E
200	1476421	EPCO-16-200-3P-ST-E
Spindle pitch 8 mm, with encoder		
50	1476522	EPCO-16-50-8P-ST-E
100	1476524	EPCO-16-100-8P-ST-E
150	1476526	EPCO-16-150-8P-ST-E
200	1476528	EPCO-16-200-8P-ST-E

EPCO-25		
Stroke [mm]	Part No.	Type
Spindle pitch 3 mm, with encoder		
50	1470698	EPCO-25-50-3P-ST-E
100	1470700	EPCO-25-100-3P-ST-E
150	1470702	EPCO-25-150-3P-ST-E
200	1470704	EPCO-25-200-3P-ST-E
300	1470706	EPCO-25-300-3P-ST-E
Spindle pitch 10 mm, with encoder		
50	1470769	EPCO-25-50-10P-ST-E
100	1470771	EPCO-25-100-10P-ST-E
150	1470773	EPCO-25-150-10P-ST-E
200	1470775	EPCO-25-200-10P-ST-E
300	1470777	EPCO-25-300-10P-ST-E

EPCO-40		
Stroke [mm]	Part No.	Type
Spindle pitch 5 mm, with encoder		
50	1472501	EPCO-40-50-5P-ST-E
100	1472503	EPCO-40-100-5P-ST-E
150	1472505	EPCO-40-150-5P-ST-E
200	1472507	EPCO-40-200-5P-ST-E
300	1472509	EPCO-40-300-5P-ST-E
Spindle pitch 12.7 mm, with encoder		
50	1472617	EPCO-40-50-12.7P-ST-E
100	1472619	EPCO-40-100-12.7P-ST-E
150	1472621	EPCO-40-150-12.7P-ST-E
200	1472623	EPCO-40-200-12.7P-ST-E
300	1472625	EPCO-40-300-12.7P-ST-E

Accessories

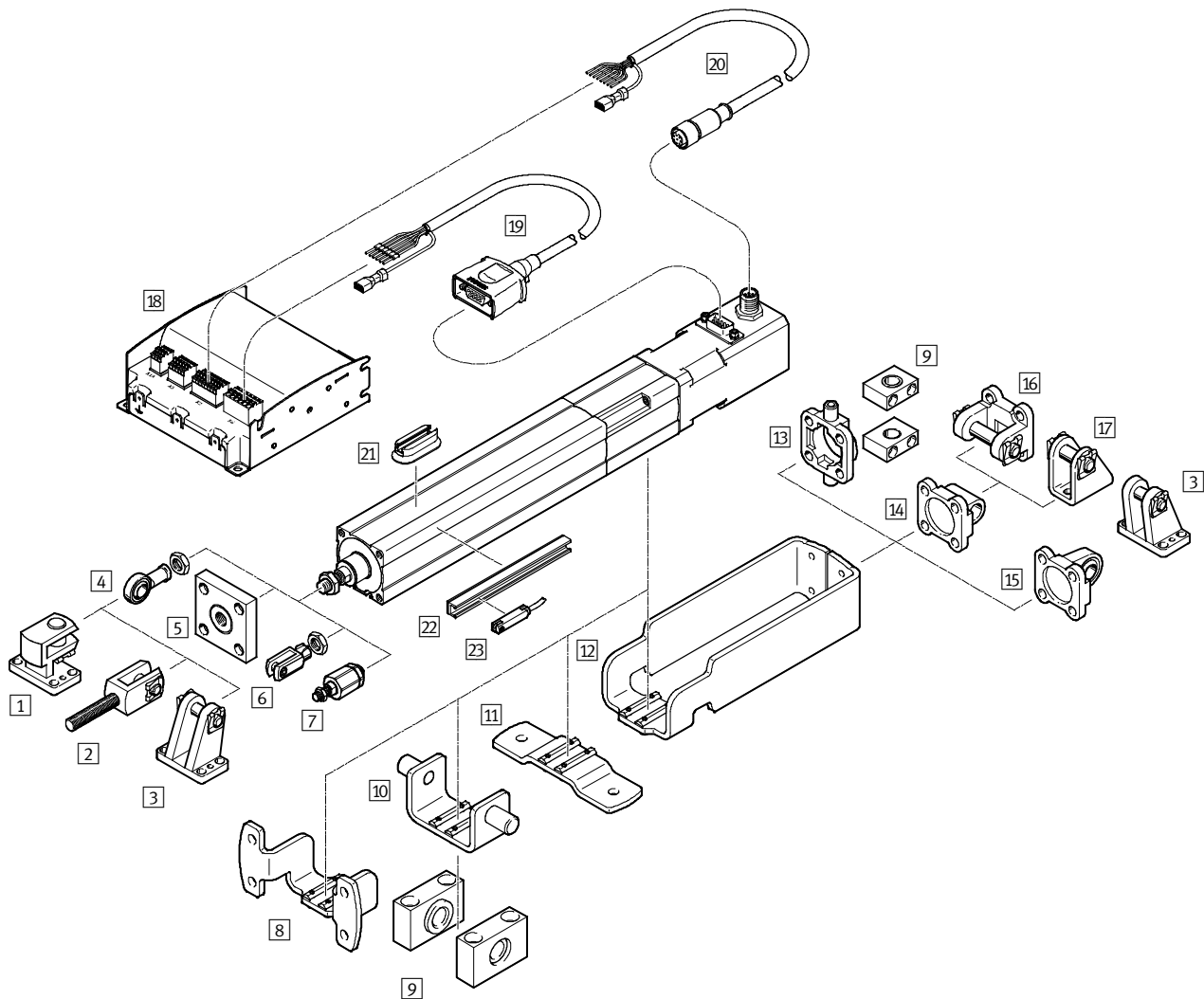

		For size			→ Page/online
		16	25	40	
1	Right-angle clevis foot LQG	-	-	■	302
2	Rod clevis SGA	-	-	■	302
3	Clevis foot LBG	-	-	■	302
4	Rod eye SGS	■	■	■	302
5	Coupling piece KSG	-	-	■	302
6	Rod clevis SG	■	■	■	302
7	Self-aligning rod coupler FK	■	■	■	302
8	Flange mounting EAHH	■	■	■	302
9	Trunnion support LNZG	■	■	■	302
10	Swivel mounting EAHS	■	■	■	302
11	Foot mounting EAHF	■	■	■	302
12	Adapter kit EAHA	■	■	■	302
13	Trunnion flange ZNCF	-	-	■	302

		For size			→ Page/online
		16	25	40	
14	Swivel flange SNCL	■	■	■	302
15	Swivel flange SNCS	-	-	■	302
16	Swivel flange SNCB	-	-	■	302
17	Clevis foot LBN	■	■	■	302
18	Controller CMMO	■	■	■	460
19	Motor cable NEBM	■	■	■	304
20	Encoder cable NEBM	■	■	■	304
21	Mounting kit CRSMB	■	■	■	303
22	Sensor rail SAMH	■	■	■	303
23	Proximity sensor SME/SMT-8	■	■	■	303

Note









For applications involving high loads, the cylinder must not be mounted exclusively via the mounting thread on the front.









The mass of the motor can be amplified by the lever effect, which can result in the mounting thread being torn out.

Electric cylinders EPCO, with spindle drive

FESTO





Accessories – Ordering data

	For size	Part No.	Type
1 Right-angle clevis foot Technical data online: → lqg			
	40	31769	LQG-40
2 Rod clevis Technical data online: → sga			
	40	32954	SGA-M10X1,25
3 Clevis foot Technical data online: → lbg			
	40	31762	LBG-40
4 Rod eye Technical data online: → sgs			
	16	★ 9254	SGS-M6
	25	★ 9255	SGS-M8
	40	★ 9261	SGS-M10X1,25
5 Coupling piece Technical data online: → ksg			
	40	32963	KSG-M10X1,25
6 Rod clevis Technical data online: → sg			
	16	★ 3110	SG-M6
	25	★ 3111	SG-M8
	40	★ 6144	SG-M10X1,25
7 Self-aligning rod coupler Technical data online: → fk			
	16	★ 2061	FK-M6
	25	★ 2062	FK-M8
	40	★ 6140	FK-M10X1,25
8 Flange mounting Dimensions online: → epco			
	16	★ 1434906	EAHH-P1-16
	25	★ 1434907	EAHH-P1-25
	40	★ 1434908	EAHH-P1-40
9 Trunnion support Technical data online: → lnzg			
	16	1434912	LNZG-16
	25	32959	LNZG-32
	40	★ 32960	LNZG-40/50

	For size	Part No.	Type
10 Swivel mounting Dimensions online: → epco			
	16	★ 1434909	EAHS-P1-16
	25	★ 1434910	EAHS-P1-25
	40	★ 1434911	EAHS-P1-40
11 Foot mounting EAHF Dimensions online: → epco			
	16	★ 1434903	EAHF-P1-16
	25	★ 1434904	EAHF-P1-25
	40	★ 1434905	EAHF-P1-40
12 Adapter kit EAHA Dimensions online: → epco			
	16	★ 1434900	EAHA-P1-16
	25	★ 1434901	EAHA-P1-25
	40	★ 1434902	EAHA-P1-40
13 Trunnion flange ZNCF Dimensions online: → epco			
	40	174412	ZNCF-40
14 Swivel flange SNCL Dimensions online: → epco			
	16	537791	SNCL-16
	25	537793	SNCL-25
	40	★ 174405	SNCL-40
15 Swivel flange SNCS Dimensions online: → epco			
	40	★ 174398	SNCS-40
16 Swivel flange SNCB Dimensions online: → epco			
	40	★ 174391	SNCB-40
17 Clevis foot Technical data online: → lbn			
	16	★ 6058	LBN-12/16
	25	★ 6059	LBN-20/25
	40	195861	LBN-40

3

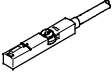
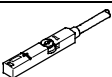
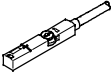
Accessories – Ordering data

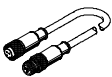
	For size	Part No.	Type
21 Mounting kit for proximity sensor			
	16, 25, 40	525565	CRSMB-8-32/100 ¹⁾
22 Sensor rail⁴⁾ for proximity sensor			
	16, 25, 40	1600093	SAMH-N8-SR-50 ²⁾
		1600118	SAMH-N8-SR-100 ³⁾
23 Proximity sensor for T-slot, magneto-resistive – N/O contact Technical data → 737			
	PNP, cable	★	574335 SMT-8M-A-PS-24V-E-2,5-OE
	PNP, plug	★	574334 SMT-8M-A-PS-24V-E-0,3-M8D
	PNP, plug	★	574337 SMT-8M-A-PS-24V-E-0,3-M12
	NPN, cable	★	574338 SMT-8M-A-NS-24V-E-2,5-OE
	NPN, plug	★	574339 SMT-8M-A-NS-24V-E-0,3-M8D
Magneto-resistive – N/C contact Technical data → 737			
	PNP, cable	★	574340 SMT-8M-A-PO-24V-E-7,5-OE
23 Proximity sensor for T-slot, magnetic reed – N/O contact Technical data → 732			
	Cable	★	543862 SME-8M-DS-24V-K-2,5-OE
	Cable	★	543863 SME-8M-DS-24V-K-5,0-OE
	Cable	★	543872 SME-8M-ZS-24V-K-2,5-OE
	Plug	★	543861 SME-8M-DS-24V-K-0,3-M8D
Magnetic reed – N/C contact Technical data → 734			
	Cable	★	150855 SME-8-K-LED-24
	Plug		150857 SME-8-S-LED-24
Magnetic reed – N/C contact Technical data → 734			
	Cable		160251 SME-8-O-K-LED-24
Connecting cable			
	0.5 m		175488 KM8-M8-GSGD-0,5
	1 m		175489 KM8-M8-GSGD-1
	2.5 m		165610 KM8-M8-GSGD-2,5
	5 m		165611 KM8-M8-GSGD-5

1) Length: 35 mm.
 2) Length: 50 mm.
 3) Length: 100 mm.
 4) Size 25 can only be used with proximity sensor SMT-8 (magneto-resistive).



Electric cylinders EPCO, with spindle drive

FESTO

Accessories – Ordering data

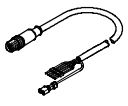
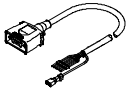
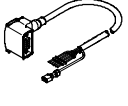
3

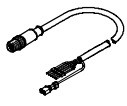
	Cable length		Part No.	Type
19 Motor cable¹⁾				
for EPCO-16				
Straight plug				
	1.5 m	★	1449600	NEBM-M12G8-E-1.5-Q5-LE6
	2.5 m	★	1449601	NEBM-M12G8-E-2.5-Q5-LE6
	5 m	★	1449602	NEBM-M12G8-E-5-Q5-LE6
	7 m	★	1449603	NEBM-M12G8-E-7-Q5-LE6
	10 m	★	1449604	NEBM-M12G8-E-10-Q5-LE6
For EPCO-25/-40				
Straight plug				
	1.5 m		1450368	NEBM-S1G9-E-1.5-Q5-LE6
	2.5 m		1450369	NEBM-S1G9-E-2.5-Q5-LE6
	5 m		1450370	NEBM-S1G9-E-5-Q5-LE6
	7 m		1450371	NEBM-S1G9-E-7-Q5-LE6
	10 m		1450372	NEBM-S1G9-E-10-Q5-LE6
Angled plug				
	1.5 m	★	1450736	NEBM-S1W9-E-1.5-Q5-LE6
	2.5 m	★	1450737	NEBM-S1W9-E-2.5-Q5-LE6
	5 m	★	1450738	NEBM-S1W9-E-5-Q5-LE6
	7 m	★	1450739	NEBM-S1W9-E-7-Q5-LE6
	10 m	★	1450740	NEBM-S1W9-E-10-Q5-LE6

	Cable length		Part No.	Type
20 Encoder cable¹⁾				
for EPCO-16/-25/-40				
Straight plug				
	1.5 m	★	1451586	NEBM-M12G8-E-1.5-LE8
	2.5 m	★	1451587	NEBM-M12G8-E-2.5-LE8
	5 m	★	1451588	NEBM-M12G8-E-5-LE8
	7 m	★	1451589	NEBM-M12G8-E-7-LE8
	10 m	★	1451590	NEBM-M12G8-E-10-LE8
For EPCO-25/-40				
Angled plug				
	1.5 m	★	1451674	NEBM-M12W8-E-1.5-LE8
	2.5 m	★	1451675	NEBM-M12W8-E-2.5-LE8
	5 m	★	1451676	NEBM-M12W8-E-5-LE8
	7 m	★	1451677	NEBM-M12W8-E-7-LE8
	10 m	★	1451678	NEBM-M12W8-E-10-LE8

1) Other cable lengths on request.

Sensor mounting

The sensor mountings can only be attached within the highlighted area due to the asymmetry of the internal magnets.

The proximity sensors may not switch reliably if they are mounted outside of this area.

The overall length of the sensor rail SAMH corresponds to the length of the sensing range plus approx. 10 mm adjustment range on either side for the proximity sensors.

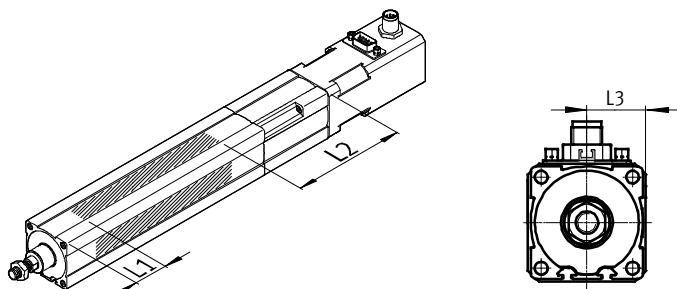

Size	L1	L2	L3
16	29	95	15
25	33	121	20
40	40	150	27.5

Dimensions

EPCO-16

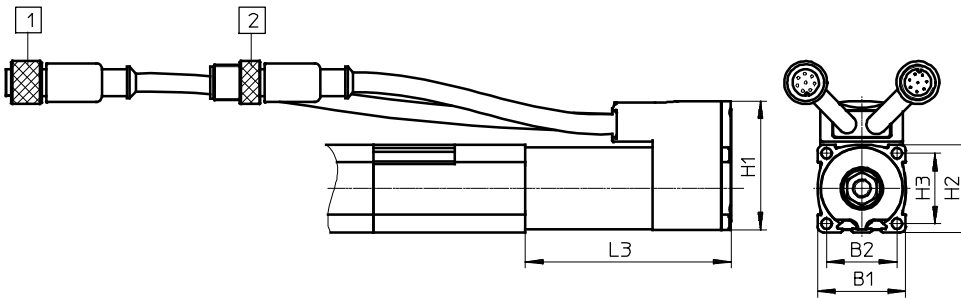

- 1 Motor connection:
Round plug M12, 8-pin, socket
Cable length: 350 mm
- 2 Encoder connection:
Round plug M12, 8-pin, pins
Cable length: 250 mm

EPCO-25/-40

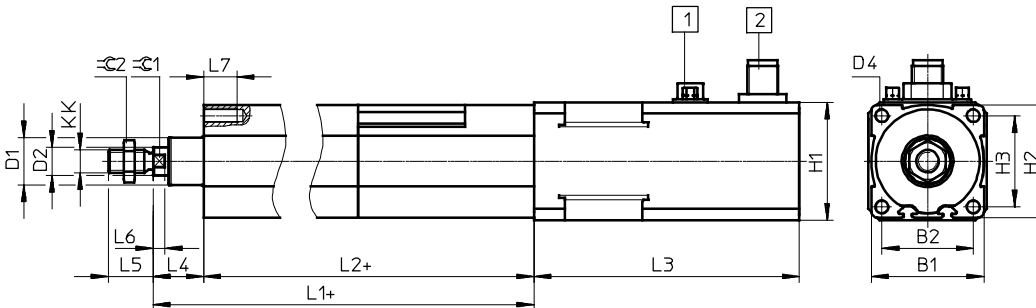

- 1 Motor connection:
Sub-D plug, 9-pin, pins
 - 2 Encoder connection:
Round plug M12, 8-pin, pins
- + = plus stroke length

Size	B1	B2	D1 ∅ ±0.05	D4	H1	H2	H3	KK	L1	L2 ±1
16	30	24	13.27	M4	44	30	24	M6	143	127
25	40	32.5	17.27	M5	42 ^{+0.3}	40	32.5	M8	174.6	156.6
40	55	42	26.52	M6	56.4	55	42	M10x1.25	214.2	192.7

Size	L3				L4	L5	L6	L7	MM	⌀C1	⌀C2
	-E	-B	-EB								
16	70±1	70±1	96±1.5	96±1.5	16	12	3.7	10	8	7	10
25	66±1	94.4±1.2	114.4±1.3	127.4±1.3	18	16	4.2	12	10	9	13
40	73.5±0.8	102.5±1.1	123.5±1.1	138±1.1	21.5	19	4.7	14	12	10	17

Electric cylinders ESBF, with spindle drive

3



- Electromechanical linear axis with piston rod based on ISO 15552
- Ball screw spindle
- Axial or parallel (U-shaped) motor mounting
- Comprehensive range of accessories
- Spare parts service
- ★ Quick ordering of basic designs → 308

→ www.festo.com/catalogue/esbf

Product range overview

Type/version	Size	Stroke [mm]	Feed force [kN]	Spindle pitch [mm/rev.]						
				5	10	15	20	25	32	40
ESBF										
Ball screw spindle	63	1 ... 1,200	7	■	■	-	-	■	-	-
	80	1 ... 1,500	12	■	-	■	-	-	■	-
	100	1 ... 1,500	17	■	-	-	■	-	-	■

Product options

F	Female piston rod thread	S1	Protection class IP65	F1	Lubrication approved for use in food applications	...E	Piston rod extension
		R3	High corrosion protection				

Technical data

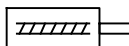

Technical data		Dimensions → 313								
Size		63			80			100		
Spindle pitch	[mm/rev.]	5	10	25	5	15	32	5	20	40
Spindle diameter	[mm]	25			32			40		
Max. force of the cylinder ¹⁾	[kN]	7	7	6	12	12	10	17	17	14.5
Max. driving torque	[Nm]	7	13.1	26.5	11.9	33.7	56.6	16.9	63.7	102.6
Max. radial force ²⁾	[N]	700			1,100			1,100		
Max. speed	[m/s]	0.27	0.53	1.35	0.21	0.62	1.34	0.16	0.67	1.34
Max. rotational speed	[rpm]	3,250	3,220	3,260	2,530	2,515	2,515	2,010	2,010	2,010
Max. acceleration	[m/s ²]	5	15	25	5	15	25	5	15	25
Max. angle of rotation at the piston rod	[°]	±0.4			±0.5			±0.5		
Reversing backlash ³⁾	[mm]	< 0.03	< 0.03	< 0.04	< 0.03	< 0.03	< 0.04	< 0.03	< 0.03	< 0.04
Repetition accuracy	[mm]	±0.015		±0.01						
No-load driving torque ⁴⁾	[Nm]	0.3	0.3	0.4	0.9	1.1	1.3	1.3	1.1	1.5

- 1) The feed force is dependent on the stroke.
- 2) At the drive shaft.
- 3) In new condition.
- 4) At a spindle speed of 200 rpm.

Note

PositioningDrives
sizing software
→ www.festo.com

Mass moment of inertia		63			80			100		
Size		5	10	25	5	15	32	5	20	40
Spindle pitch	[mm/rev.]	5	10	25	5	15	32	5	20	40
J_0 with 0 mm stroke	[kg cm ²]	0.491	0.486	0.65	1.529	1.648	2.119	4.696	5.050	6.17
j_S per meter stroke	[kg cm ² /m]	2.832	2.859	3.053	7.699	7.815	8.277	18.978	19.31	20.372
j_L per kg effective load	[kg cm ² /kg]	0.006	0.025	0.158	0.006	0.057	0.259	0.006	0.101	0.405

The mass moment of inertia J_A of the electric cylinder is calculated as follows:

$$J_A = J_0 + j_S \times \text{working stroke [m]} + j_L \times m_{\text{moving effective load [kg]}}$$

Operating conditions

Ambient temperature ⁵⁾	[°C]	0 ... +50
Protection class		IP40

- 5) Note operating range of proximity sensors and motors.

Materials

Bearing cap	Coated gravity die-cast aluminium
Cylinder barrel	Smooth anodised wrought aluminium alloy
Piston rod	High-alloy stainless steel
Spindle	Rolled steel
Spindle nut	Rolled steel
Drive cover	Coated die-cast aluminium

Electric cylinders ESBF, with spindle drive

Order code

Type

ESBF	Electric cylinder
------	-------------------

Drive type

BS	Ball screw spindle
----	--------------------

Size

	Stroke [mm]	Spindle pitch [mm]
63	1 ... 1,200	5P, 10P, 25P
80	1 ... 1,500	5P, 15P, 32P
100	1 ... 1,500	5P, 20P, 40P

ESBF

BS

Ordering – Product options

Configurable product

This product and all its options can be ordered using the configurator.

The configurator can be found under Products on the DVD or

→ www.festo.com/catalogue/...

Enter the type code in the search field.

★ Quick ordering

ESBF-63		
Stroke [mm]	Part No.	Type
Spindle pitch 5 mm		
100	574093	ESBF-BS-63-100-5P
200	1347390	ESBF-BS-63-200-5P
300	574094	ESBF-BS-63-300-5P
400	574095	ESBF-BS-63-400-5P
Spindle pitch 10 mm		
100	574096	ESBF-BS-63-100-10P
200	574097	ESBF-BS-63-200-10P
300	574098	ESBF-BS-63-300-10P
400	574099	ESBF-BS-63-400-10P
Spindle pitch 25 mm		
100	574100	ESBF-BS-63-100-25P
200	574101	ESBF-BS-63-200-25P
300	574102	ESBF-BS-63-300-25P
400	574103	ESBF-BS-63-400-25P

ESBF-80		
Stroke [mm]	Part No.	Type
Spindle pitch 5 mm		
100	574104	ESBF-BS-80-100-5P
200	1347391	ESBF-BS-80-200-5P
300	574105	ESBF-BS-80-300-5P
400	574106	ESBF-BS-80-400-5P
Spindle pitch 15 mm		
100	574107	ESBF-BS-80-100-15P
200	574108	ESBF-BS-80-200-15P
300	574109	ESBF-BS-80-300-15P
400	574110	ESBF-BS-80-400-15P
Spindle pitch 32 mm		
100	574111	ESBF-BS-80-100-32P
200	574112	ESBF-BS-80-200-32P
300	574113	ESBF-BS-80-300-32P
400	574114	ESBF-BS-80-400-32P

ESBF-100		
Stroke [mm]	Part No.	Type
Spindle pitch 5 mm		
100	574115	ESBF-BS-100-100-5P
200	1347393	ESBF-BS-100-200-5P
300	574116	ESBF-BS-100-300-5P
400	574117	ESBF-BS-100-300-5P
Spindle pitch 20 mm		
100	574118	ESBF-BS-100-100-20P
200	574119	ESBF-BS-100-200-20P
300	574120	ESBF-BS-100-300-20P
400	574121	ESBF-BS-100-400-20P
Spindle pitch 40 mm		
100	574122	ESBF-BS-100-100-40P
200	574123	ESBF-BS-100-200-40P
300	574124	ESBF-BS-100-300-40P
400	574125	ESBF-BS-100-400-40P

Accessories

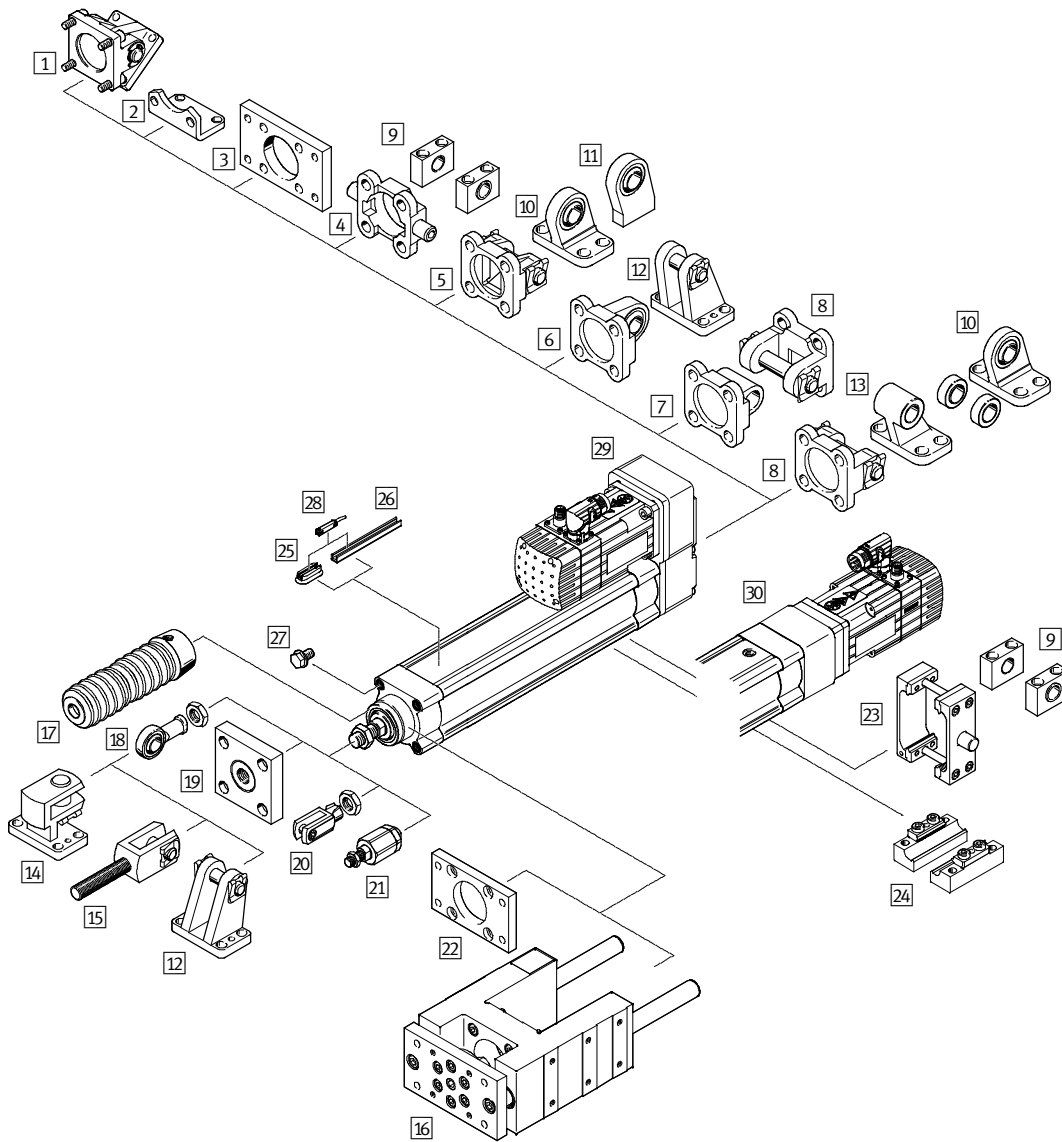

3

		Suitable for high forces ¹⁾	→ Page/online
1	Swivel flange DAMS	■	310
2	Foot mounting HNC/CRHNC	–	310
3	Flange mounting FNC/CRFNG	–	310
4	Trunnion flange ZNCF/CRZNG	–	310
5	Swivel flange SNC	–	310
6	Swivel flange SNCS	–	310
7	Swivel flange SNCL	–	310
8	Swivel flange SNCB/SNCB-... R3	–	310
9	Trunnion support LNZG/CRLNZG	–	310
10	Clevis foot LSNG	–	310
11	Clevis foot LSNSG	–	310
12	Clevis foot LBG	–	310
13	Clevis foot LNG/CRLNG	–	310
14	Right-angle clevis foot LQG	–	310
15	Rod clevis SGA	■	310

		Suitable for high forces ¹⁾	→ Page/online
16	Guide unit EAGF	–	310
17	Protective bellows kit EADB	■	esbf
18	Rod eye SGS/CRSGS	■	311
19	Coupling piece KSZ	–	311
20	Rod clevis SG/CRSG	■	311
21	Self-aligning rod coupler FK	–	311
22	Flange mounting EAAH	■	311
23	Trunnion mounting kit DAMT	–	311
24	Profile mounting EAHF-...-P	■	311
25	Mounting kit CRSMB	■	311
26	Sensor rail SAMH	■	311
27	Blanking screw DAMD-PS	■	311
28	Proximity sensor SME/SMT-8 and connecting cable NEBU	■	311
29	Parallel kit EAMM-U	■	312
30	Axial kit EAMM-A	■	312



1) Shows which accessories can be used within the entire force range. For restricted force ranges see the relevant accessory part, from page 310.

Electric cylinders ESBF, with spindle drive

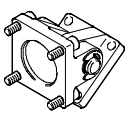
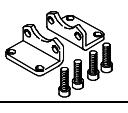
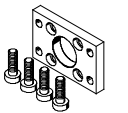
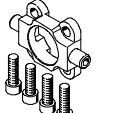
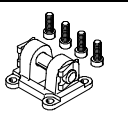
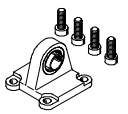
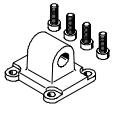
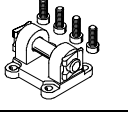
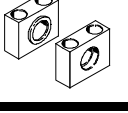
Accessories – Ordering data

	For size	1) [kN]	Part No.	Type
1 Swivel flange Dimensions online: → esbf				
	63	7	★ 1555443	DAMS-K-V1-63-V-R3
	80	12	★ 1556588	DAMS-K-V1-80-V-R3
	100	17	★ 1560237	DAMS-K-V1-100-V-R3
2 Foot mounting Dimensions online: → esbf				
	63	4	★ 174372	HNC-63
	80	6	174373	HNC-80
	100	9	174374	HNC-100
3 Flange mounting Dimensions online: → esbf				
	63	7	★ 174379	FNC-63
	80	12	174380	FNC-80
	100	17	174381	FNC-100
4 Trunnion flange Dimensions online: → esbf				
	63	4	174414	ZNCF-63
	80	6	174415	ZNCF-80
	100	9	174416	ZNCF-100
5 Swivel flange Technical data online: → snc				
	63	4	★ 174386	SNC-63
	80	6	174387	SNC-80
	100	9	174388	SNC-100
6 Swivel flange Technical data online: → snsc				
	63	4	★ 174400	SNCS-63
	80	6	174401	SNCS-80
	100	9	174402	SNCS-100
7 Swivel flange Dimensions online: → sncl				
	63	4	★ 174407	SNCL-63
	80	6	174408	SNCL-80
	100	9	174409	SNCL-100
8 Swivel flange Dimensions online: → sncb				
	63	4	★ 174393	SNCB-63
	80	6	174394	SNCB-80
	100	9	174395	SNCB-100
9 Trunnion support Dimensions online: → esbf				
	63, 80	–	32961	LNZG-63/80
	100	–	32962	LNZG-100/125

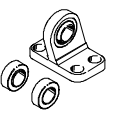
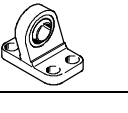

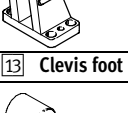
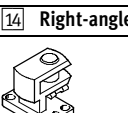
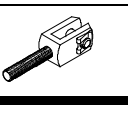
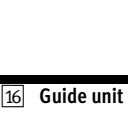
1) Max. load capacity.

	For size	1) [kN]	Part No.	Type
10 Clevis foot Technical data online: → lsn				
	63	–	5564	LSN-63
	80	–	5565	LSN-80
	100	–	5566	LSN-100
10 Clevis foot Technical data online: → lsng				
	63	–	31743	LSNG-63
	80	–	31744	LSNG-80
	100	–	31745	LSNG-100
11 Clevis foot Technical data online: → lsng				
	63	–	31750	LSNSG-63
	80	–	31751	LSNSG-80
	100	–	31752	LSNSG-100
12 Clevis foot Technical data online: → lbg				
	63	–	31764	LBG-63
	80	–	31765	LBG-80
	100	–	31766	LBG-100
13 Clevis foot Technical data online: → lng				
	63	–	★ 33893	LNG-63
	80	–	33894	LNG-80
	100	–	33895	LNG-100
14 Right-angle clevis foot Technical data online: → lqg				
	63	–	31771	LQG-63
	80	–	31772	LQG-80
	100	–	31773	LQG-100
15 Rod clevis Technical data online: → sga				
	63	10	10768	SGA-M16x1,5
	80, 100	10	10769	SGA-M20x1,5

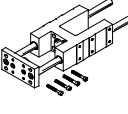

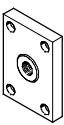

1) Max. load capacity.

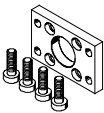
	Stroke [mm]	Part No.	Type
16 Guide unit for fixed strokes, with recirculating ball bearing guide Technical data online: → eagf			
	For size 63		
	100	1725842	EAGF-V2-KF-63-100
	200	1725843	EAGF-V2-KF-63-200
	320	1725844	EAGF-V2-KF-63-320
	400	1725845	EAGF-V2-KF-63-400
	For size 80		
	100	1725846	EAGF-V2-KF-80-100
	200	1725847	EAGF-V2-KF-80-200
	320	1725848	EAGF-V2-KF-80-320
	400	1725849	EAGF-V2-KF-80-400
	For size 100		
	100	1725850	EAGF-V2-KF-100-100
	200	1725851	EAGF-V2-KF-100-200
320	1725852	EAGF-V2-KF-100-320	
400	1725853	EAGF-V2-KF-100-400	

Accessories – Ordering data

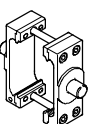
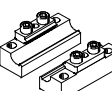
	For size	1) [kN]	Part No.	Type
18 Rod eye Technical data online: → sgs				
	63	10	★ 9263	SGS-M16x1,5
	80, 100	10	9264	SGS-M20x1,5
19 Coupling piece Technical data online: → ksz				
	63	10	36127	KSZ-M16x1,5
	80, 100	10	36128	KSZ-M20x1,5
20 Rod clevis Technical data online: → sg				
	63	10	★ 6146	SG-M16x1,5
	80, 100	10	6147	SG-M20x1,5
21 Self-aligning rod coupler Technical data online: → fk				
	63	10	★ 6142	FK-M16x1,5
	80, 100	10	6143	FK-M20x1,5
22 Flange mounting Dimensions online: → esbf				
	63	7	★ 1502305	EAHH-V2-63-R1
	80	12	★ 1502306	EAHH-V2-80-R1
	100	17	★ 1502307	EAHH-V2-100-R1



1) Max. load capacity.

	For size	1) [kN]	Part No.	Type
23 Trunnion mounting kit Dimensions online: → esbf				
	63	4	2214971	DAMT-V1-63-A
	80	6	163529	DAMT-V1-80-A
	100	9	163530	DAMT-V1-100-A
24 Profile mounting Dimensions online: → esbf				
	63	3.5	★ 1547781	EAHF-V2-50/63-P
	80, 100	6	★ 1547780	EAHF-V2-80/100-P
25 Mounting kit Dimensions online: → esbf				
	63, 80, 100	-	525565	CRSMB-8-32/100
26 Sensor rail²⁾ Dimensions online: → esbf				
	63, 80, 100	-	1600118	SAMH-N8-SR-100
27 Blanking screw³⁾ Dimensions online: → esbf				
	63	-	650121	DAMD-PS-M8-16-R1
	80, 100	-	1355026	DAMD-PS-M10-16-R1

1) Max. load capacity.



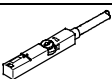
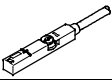
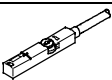

2) Length = 100 mm.

3) Packaging unit 4 pieces.

	Part No.	Type
28 Proximity sensor for T-slot, magneto-resistive – N/O contact Technical data → 737		
	PNP, cable	★ 574335 SMT-8M-A-PS-24V-E-2,5-OE
	PNP, plug	★ 574334 SMT-8M-A-PS-24V-E-0,3-M8D
	PNP, plug	★ 574337 SMT-8M-A-PS-24V-E-0,3-M12
	NPN, cable	★ 574338 SMT-8M-A-NS-24V-E-2,5-OE
	NPN, plug	★ 574339 SMT-8M-A-NS-24V-E-0,3-M8D
Magneto-resistive – N/C contact Technical data → 737		
	PNP, cable	★ 574340 SMT-8M-A-PO-24V-E-7,5-OE
28 Proximity sensor for T-slot, magnetic reed – N/O contact Technical data → 732		
	Cable	★ 543862 SME-8M-DS-24V-K-2,5-OE
	Cable	★ 543863 SME-8M-DS-24V-K-5,0-OE
	Cable	★ 543872 SME-8M-ZS-24V-K-2,5-OE
	Plug	★ 543861 SME-8M-DS-24V-K-0,3-M8D
Magnetic reed – N/C contact Technical data → 734		
	Cable	160251 SME-8-O-K-LED-24

Electric cylinders ESBF, with spindle drive

Accessories – Ordering data

	Cable length		Part No.	Type	
28 Connecting cable, straight socket					Technical data → 949
	2.5 m	★	541333	NEBU-M8G3-K-2.5-LE3	
	5.0 m	★	541334	NEBU-M8G3-K-5-LE3	
	2.5 m		541363	NEBU-M12G5-K-2.5-LE3	
	5.0 m		541364	NEBU-M12G5-K-5-LE3	
Angled socket					Technical data → 949
	2.5 m	★	541338	NEBU-M8W3-K-2.5-LE3	
	5.0 m	★	541341	NEBU-M8W3-K-5-LE3	
	2.5 m		541367	NEBU-M12W5-K-2.5-LE3	
	5.0 m		541370	NEBU-M12W5-K-5-LE3	

3

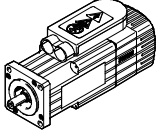
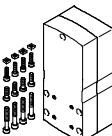
Motor	Parallel kit	
		
	Part No.	Type
29 Permissible axis/motor combination with parallel kit –		
Technical data online: → eamm-u		
ESBF-63		
With servo motor		
EMMS-AS-70-...	★ 1212477	EAMM-U-86-D60-70A-102
	★ 1212835	EAMM-U-86-D60-70A-102-S1 ¹⁾
EMMS-AS-100-...	★ 1202436	EAMM-U-110-D60-100A-120
	★ 1203112	EAMM-U-110-D60-100A-120-S1 ¹⁾
With gear unit		
EMGA-60-P-...	1586347	EAMM-U-86-D60-60G-102
	1437163	EAMM-U-86-D60-60G-102-S1 ¹⁾
EMGA-60-P-...	1543240	EAMM-U-110-D60-60G-120
	1436183	EAMM-U-110-D60-60G-120-S1 ¹⁾
EMGA-80-P-...	1532949	EAMM-U-110-D60-80G-120
	1530875	EAMM-U-110-D60-80G-120-S1 ¹⁾
ESBF-80		
With servo motor		
EMMS-AS-100-...	★ 1465438	EAMM-U-110-D80-100A-120
	★ 1433650	EAMM-U-110-D80-100A-120-S1 ¹⁾
EMMS-AS-140-...	★ 1465530	EAMM-U-145-D80-140A-188
	★ 1433709	EAMM-U-145-D80-140A-188-S1 ¹⁾
With gear unit		
EMGA-80-P-...	1589614	EAMM-U-110-D80-80G-120
	1589706	EAMM-U-110-D80-80G-120-S1 ¹⁾
ESBF-100		
With servo motor		
EMMS-AS-140-...	★ 1465541	EAMM-U-145-D100-140A-188
	★ 1433852	EAMM-U-145-D100-140A-188-S1 ¹⁾

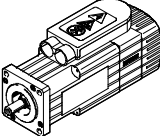
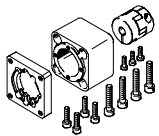
Motor	Axial kit	
		
	Part No.	Type
30 Permissible axis/motor combination with axial kit –		
Technical data online: → eamm-a		
ESBF-63		
With servo motor		
EMMS-AS-70-...	★ 543161	EAMM-A-D60-70A
	★ 1679566	EAMM-A-D60B-70A-S1 ¹⁾
EMMS-AS-100-...	★ 550983	EAMM-A-D60-100A
	★ 1679518	EAMM-A-D60B-100A-S1 ¹⁾
With servo motor and gear unit		
EMMS-AS-55-...	560283	EAMM-A-D60-60G
EMGA-60-P-G...-SAS-55		
EMMS-AS-70-...	560283	EAMM-A-D60-60G
EMGA-60-P-G...-SAS-70		
With stepper motor and gear unit		
EMMS-ST-57-...	560283	EAMM-A-D60-60G
EMGA-60-P-G...-SST-57		
ESBF-80		
With servo motor		
EMMS-AS-100-...	★ 1589665	EAMM-A-D80-100A
	★ 1600673	EAMM-A-D80B-100A-S1 ¹⁾
EMMS-AS-140-...	★ 1588299	EAMM-A-D80-140A
	★ 1600674	EAMM-A-D80B-140A-S1 ¹⁾
ESBF-100		
With servo motor		
EMMS-AS-140-...	★ 1588349	EAMM-A-D100-140A
	★ 1600675	EAMM-A-D100B-140A-S1 ¹⁾

1) With protection class IP65.

1) With protection class IP65.

Note

The clamping component EADT is required to adjust the toothed belt pretension with EAMM-U-110 and EAMM-U-145.

The motor and/or axis shaft can optionally be supported with a counter bearing EAMG.
More information → eamm-u

Dimensions

Download CAD data → www.festo.com

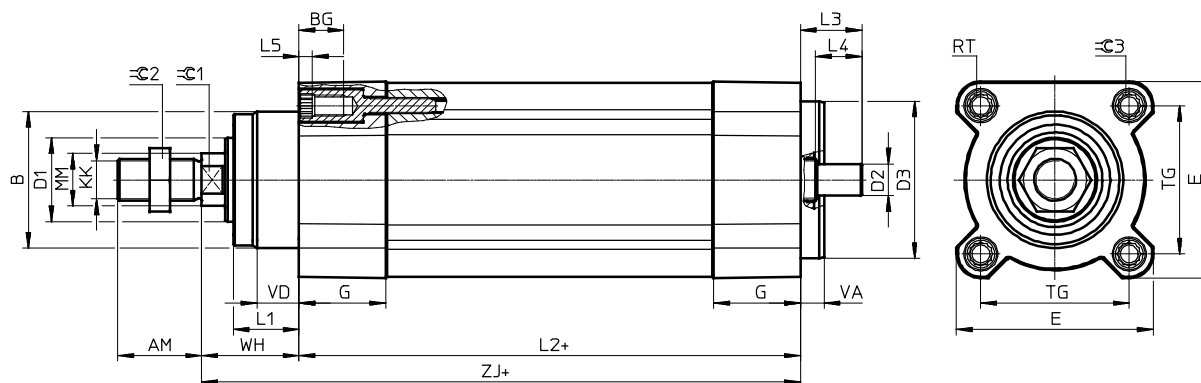

+ = plus stroke length

Size	AM	B	BG	D1	D2	D3	E	G	L1	L2	L3	L4
[mm]	-0.5	\varnothing 11	min.	\varnothing h9	\varnothing h6	\varnothing f7	+0.5/-0.1	\pm 0.1	-0.5	+0.7/-1.2	\pm 0.5	\pm 0.2
63	32	52	17	32	12	60	75	33	25	171	23.5	17
80	40	60	17	40	19	80	93	39	31	204	33.5	26
100	40	70	17	50	24	100	110	39	34	224	39.5	30

Size	L5	KK	MM	RT	TG	VA	VD	WH	ZJ	\varnothing C1	\varnothing C2	\varnothing C3
[mm]	max.		\varnothing -0.1		\pm 0.5	\pm 0.2	\pm 0.2	+1.8/-1.7				
63	5	M16x1.5	20	M8	56.5	9	16	37	208	17	24	8
80	25.9	M20x1.5	25	M10	72	10	18	46	250	22	30	6
100	25.9	M20x1.5	25	M10	89	12	20	51	275	22	30	6

Sensor mounting

The sensor mountings can only be attached within the highlighted area due to the asymmetry of the internal magnets.

The proximity sensors may not switch reliably if they are mounted outside of this area.

The overall length of the sensor rail SAMH corresponds to the length of the sensing range plus approx. 10 mm adjustment range on either side for the proximity sensors.

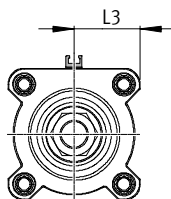
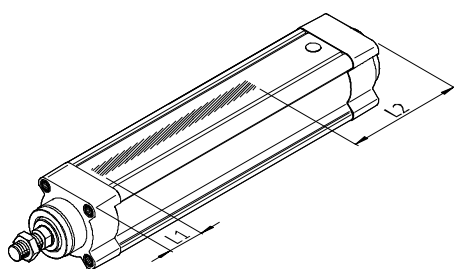

Size	L1	L2	L3
63	40	129	37
80	40	156	46
100	46	176	54.5

Electric cylinders DNCE, with spindle drive

3



- Electromechanical linear axis with piston rod based on standard ISO 15552
- Lead screw spindle and ball screw spindle
- Axial or parallel (U-shaped) motor mounting
- Comprehensive range of accessories from the DNC modular system
- Spare parts service
- ★ Quick ordering of basic designs → 316

→ www.festo.com/catalogue/dnce

Product range overview

Type/version	Size	Stroke [mm]	Feed force [N]	Spindle pitch [mm/rev.]								Product options
				1.5	2.5	3	4	5	10	12.7	20	
DNCE												
LS – Lead screw spindle	32, 40, 63	100 ... 800	300 ... 2,500	■	■	–	■	–	–	–	–	■
BS – Ball screw spindle				–	–	■	–	■	■	■	■	■

Product options

Q	Square piston rod	K3	Female piston rod thread	P5	Protection class IP65	FG	Lubrication approved for use in food applications
K8	Extended piston rod			R3	High corrosion protection		

Technical data

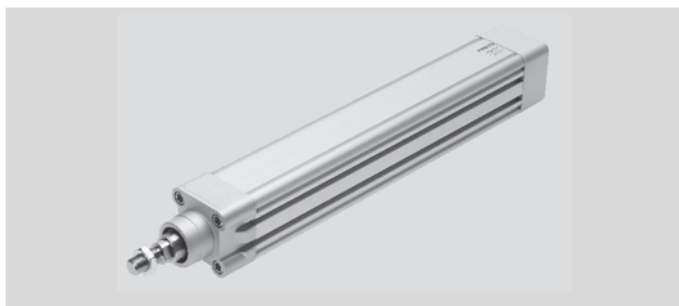
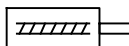

Technical data

Note

PositioningDrives
sizing software
→ www.festo.com

Dimensions → 323

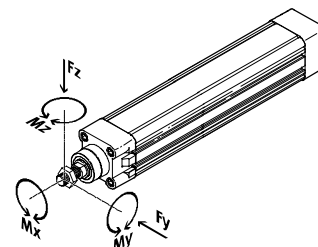

Size	32			40			63		
	LS-"1,5"	BS-"3"	BS-"10"	LS-"2,5"	BS-"5"	BS-"12,7"	LS-"4"	BS-"10"	BS-"20"
Working stroke [mm]	100 ... 400			100 ... 600			100 ... 800		
Guide value for effective load, horizontal [kg]	30	30	36	60	50	80	100	240	160
Guide value for effective load, vertical [kg]	15	15	18	30	25	40	50	120	80
Max. feed force $F_x^{1)}$ [N]	300	300	350	600	525	800	1,000	2,500	1,625
No-load driving torque with axial kit ³⁾ [Nm]	0.08	0.08	0.08	0.12	0.12	0.12	0.3	0.2	0.2
No-load driving torque with parallel kit ³⁾ [Nm]	0.13	0.13	0.13	0.22	0.22	0.22	0.6	0.5	0.5
Max. speed ¹⁾ [m/s]	0.06	0.15	0.5	0.07	0.25	0.64	0.07	0.5	1.0
Max. acceleration ¹⁾ [m/s ²]	1	6	6	1	6	6	1	6	6
Repetition accuracy [mm]	±0.07	±0.02	±0.02	±0.07	±0.02	±0.02	±0.07	±0.02	±0.02
Max. permissible force $F_y^{2)}$ [N]	105			250			310		
Max. permissible force $F_z^{2)}$ [N]	105			250			310		
Max. permissible torque M_x [Nm]	1			1			1.5		
Max. permissible torque M_y [Nm]	8			20			27		
Max. permissible torque M_z [Nm]	8			20			27		
Max. driving torque ⁴⁾ [Nm]	0.4	0.4	0.8	1.15	0.9	1.9	3.0	4.9	5.9

- 1) The values represent maximum values and are dependent on the motor variant used.
- 2) The forces are dependent on the position of the piston rod → online: dnce.
- 3) Measured at a speed of 200 rpm.
- 4) For the variant with lead screw spindle (LS), the values are dependent on the speed → online: dnce.

Operating conditions

Ambient temperature ⁵⁾ [°C]	0 ... +50
Protection class	IP40

5) Note operating range of proximity sensors and motors.

Materials

	Lead screw spindle	Ball screw spindle
End cap	Painted die-cast aluminium	Painted die-cast aluminium
Housing	Smooth anodised wrought aluminium alloy	Smooth anodised wrought aluminium alloy
Cylinder barrel	Smooth anodised wrought aluminium alloy	Smooth anodised wrought aluminium alloy
Piston rod	High-alloy stainless steel	High-alloy stainless steel
Spindle	Steel	Rolled steel
Spindle nut	POM	Rolled steel
Seals	NBR	NBR

Electric cylinders DNCE, with spindle drive

Order code

DNCE										Q	
Type											
DNCE		Electromechanical linear axis									
Size											
		Stroke [mm]									
32		100, 200, 300, 400									
40		100, 200, 300, 400, 600									
63		100, 200, 300, 400, 600, 800									
Drive function											
		Spindle pitch [mm]									
LS		"1.5"P 1									
		"2.5"P 2									
		"4"P 3									
BS		"3"P, "10"P 1									
		"5"P, "12.7"P 2									
		"10"P, "20"P 3									
Protection against rotation											
Q		Square piston rod									

3

1 Only with size 32.

2 Only with size 40.

3 Only with size 63.

Ordering – Product options



Configurable product

This product and all its options can be ordered using the configurator.

The configurator can be found under Products on the DVD or
www.festo.com/catalogue/...

Enter the type code in the search field.

★ Quick ordering

DNCE-32		
Stroke [mm]	Part No.	Type
Spindle pitch 3 mm		
100	543115	DNCE-32-100-BS-"3"P-Q
200	543116	DNCE-32-200-BS-"3"P-Q
300	543117	DNCE-32-300-BS-"3"P-Q
400	543118	DNCE-32-400-BS-"3"P-Q
Spindle pitch 10 mm		
100	543119	DNCE-32-100-BS-"10"P-Q
200	543120	DNCE-32-200-BS-"10"P-Q
300	543121	DNCE-32-300-BS-"10"P-Q
400	543122	DNCE-32-400-BS-"10"P-Q

DNCE-40		
Stroke [mm]	Part No.	Type
Spindle pitch 5 mm		
100	543127	DNCE-40-100-BS-"5"P-Q
200	543128	DNCE-40-200-BS-"5"P-Q
300	555466	DNCE-40-300-BS-"5"P-Q
400	543129	DNCE-40-400-BS-"5"P-Q
600	543130	DNCE-40-600-BS-"5"P-Q
Spindle pitch 12.7 mm		
100	543131	DNCE-40-100-BS-"12.7"P-Q
200	543132	DNCE-40-200-BS-"12.7"P-Q
300	555467	DNCE-40-300-BS-"12.7"P-Q
600	543134	DNCE-40-600-BS-"12.7"P-Q

DNCE-63		
Stroke [mm]	Part No.	Type
Spindle pitch 10 mm		
100	555470	DNCE-63-100-BS-"10"P-Q
200	543139	DNCE-63-200-BS-"10"P-Q
300	555471	DNCE-63-300-BS-"10"P-Q
400	543140	DNCE-63-400-BS-"10"P-Q
600	543141	DNCE-63-600-BS-"10"P-Q
800	543142	DNCE-63-800-BS-"10"P-Q
Spindle pitch 20 mm		
100	555472	DNCE-63-100-BS-"20"P-Q
200	543143	DNCE-63-200-BS-"20"P-Q
300	555473	DNCE-63-300-BS-"20"P-Q
400	543144	DNCE-63-400-BS-"20"P-Q
600	543145	DNCE-63-600-BS-"20"P-Q
800	543146	DNCE-63-800-BS-"20"P-Q

Accessories

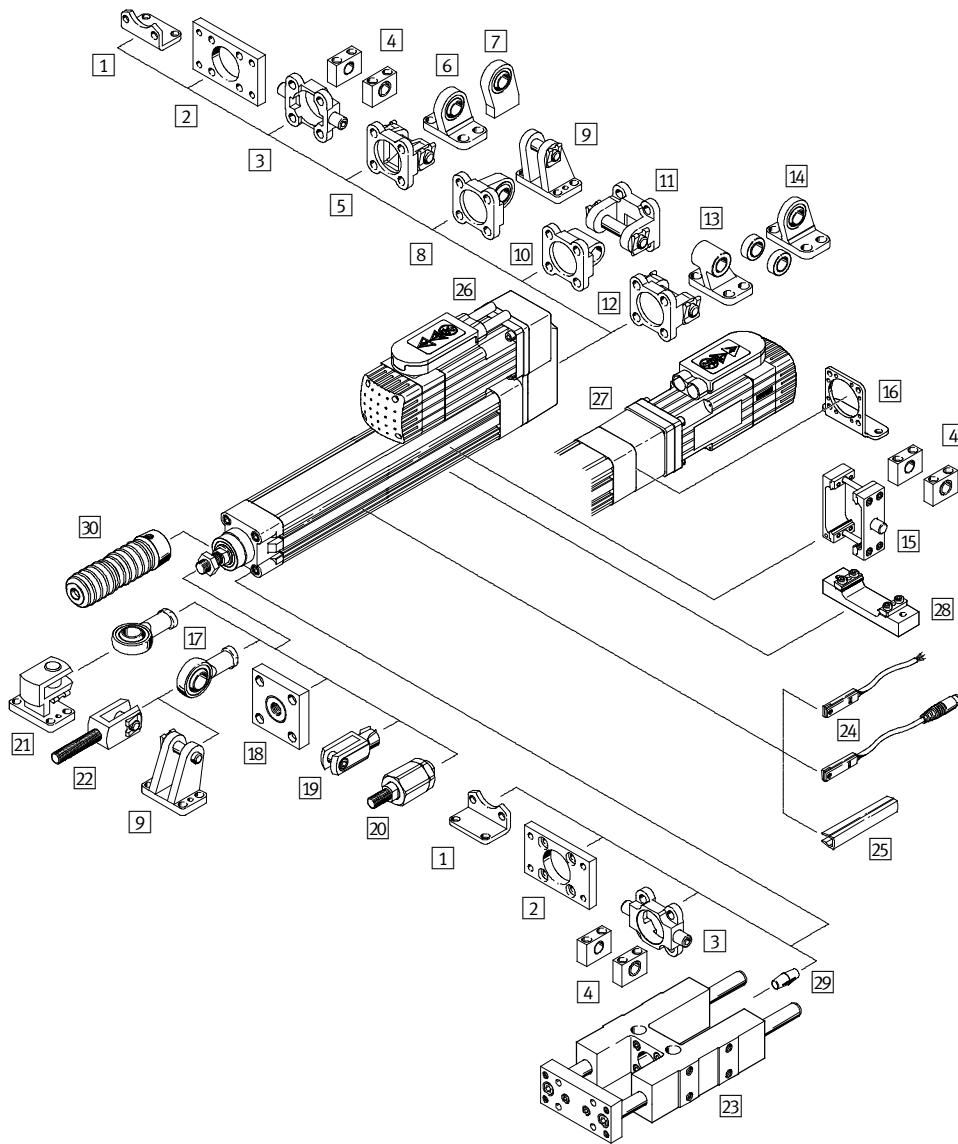



3



		→ Page/online
1	Foot mounting HNC	318
	Foot mounting CRHNC	dnce
2	Flange mounting FNC	318
	Flange mounting CRFNG	dnce
3	Trunnion flange ZNCF	318
	Trunnion flange CRZNG	dnce
4	Trunnion support LNZG	318
	Trunnion support CRLNZG	dnce
5	Swivel flange SNC	318
6	Clevis foot LSNG	318
7	Clevis foot LSNSG	318
8	Swivel flange SNCS	318
9	Clevis foot LBG	318
10	Swivel flange SNCL	318
11	Swivel flange SNCB	318
	Swivel flange SNCB-...-R3	dnce
12	Swivel flange SNCB	318
	Swivel flange SNCB-...-R3	dnce
13	Clevis foot LNG	318
	Clevis foot CRLNG	dnce

		→ Page/online
14	Clevis foot LSN	318
15	Trunnion mounting kit DAMT	318
16	Foot mounting HNCE	318
17	Rod eye SGS	318
	Rod eye CRSGS	dnce
18	Coupling piece KSZ	318
19	Rod clevis SG	318
	Rod clevis CRSG	dnce
20	Self-aligning rod coupler FK	318
21	Right-angle clevis foot LQG	318
22	Rod clevis SGA	318
23	Guide unit FENG	319
24	Proximity sensor SME-/SMT-8	319
	Connecting cable NEBU	
25	Slot cover ABP-5-S	319
26	Parallel kit EAMM-U	320
27	Axial kit EAMM-A	322
28	Profile mounting EAHF	319
29	Compensating component EADC	319
30	Protective bellows kit EADB	dnce

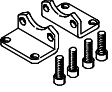
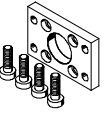
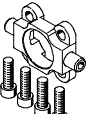
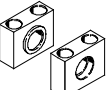
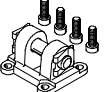
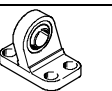
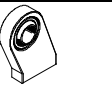
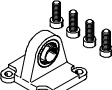
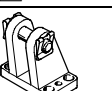
Electric cylinders DNCE, with spindle drive

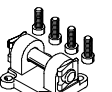
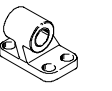

Accessories – Ordering data

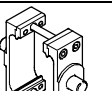
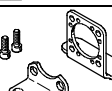
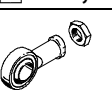
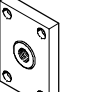
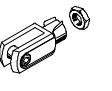
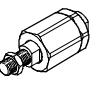
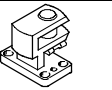
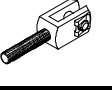
	For size		Part No.	Type
1 Foot mounting Dimensions online: → dnce				
	32	★	174369	HNC-32
	40	★	174370	HNC-40
	63	★	174372	HNC-63
2 Flange mounting Dimensions online: → dnce				
	32	★	174376	FNC-32
	40	★	174377	FNC-40
	63	★	174379	FNC-63
3 Trunnion flange Dimensions online: → dnce				
	32		174411	ZNCF-32
	40		174412	ZNCF-40
	63		174414	ZNCF-63
4 Trunnion support Dimensions online: → dnce				
	32		32959	LNZG-32
	40		32960	LNZG-40/50
	63		32961	LNZG-63/80
5 Swivel flange Technical data online: → snc				
	32	★	174383	SNC-32
	40	★	174384	SNC-40
	63	★	174386	SNC-63
6 Clevis foot Technical data online: → lsng				
	32		31740	LSNG-32
	40		31741	LSNG-40
	63		31743	LSNG-63
7 Clevis foot Technical data online: → lsng				
	32		31747	LSNSG-32
	40		31748	LSNSG-40
	63		31750	LSNSG-63
8 Swivel flange Technical data online: → snsc				
	32	★	174397	SNCS-32
	40	★	174398	SNCS-40
	63	★	174400	SNCS-63
9 Clevis foot Technical data online: → lbg				
	32		31761	LBG-32
	40		31762	LBG-40
	63		31764	LBG-63
10 Swivel flange Dimensions online: → sncl				
	32	★	174404	SNCL-32
	40	★	174405	SNCL-40
	63	★	174407	SNCL-63



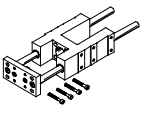

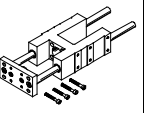
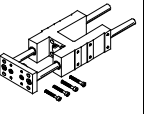
	For size		Part No.	Type
11/12 Swivel flange Dimensions online: → sncl				
	32	★	174390	SNCB-32
	40	★	174391	SNCB-40
	63	★	174393	SNCB-63
13 Clevis foot Technical data online: → lng				
	32	★	33890	LNG-32
	40	★	33891	LNG-40
	63	★	33893	LNG-63
14 Clevis foot Technical data online: → lsn				
	32		5561	LSN-32
	40		5562	LSN-40
	63		5564	LSN-63
15 Trunnion mounting kit Dimensions online: → dnce				
	32		2213233	DAMT-V1-32-A
	40		2214889	DAMT-V1-40-A
	63		2214971	DAMT-V1-63-A
16 Foot mounting Dimensions online: → dnce				
	32		547949	HNCE-32-AX
	40		547950	HNCE-40-AX
	63		547951	HNCE-63-AX
17 Rod eye Technical data online: → sgs				
	32	★	9261	SGS-M10x1,25
	40	★	9262	SGS-M12x1,25
	63	★	9263	SGS-M16x1,5
18 Coupling piece Technical data online: → ksz				
	32		36125	KSZ-M10x1,25
	40		36126	KSZ-M12x1,25
	63		36127	KSZ-M16x1,5
19 Rod clevis Technical data online: → sg				
	32	★	6144	SG-M10x1,25
	40	★	6145	SG-M12x1,25
	63	★	6146	SG-M16x1,5
20 Self-aligning rod coupler Technical data online: → fk				
	32	★	6140	FK-M10x1,25
	40	★	6141	FK-M12x1,25
	63	★	6142	FK-M16x1,5
21 Right-angle clevis foot Technical data online: → lqg				
	32		31768	LQG-32
	40		31769	LQG-40
	63		31771	LQG-63
22 Rod clevis Technical data online: → sga				
	32		32954	SGA-M10x1,25
	40		10767	SGA-M12x1,25
	63		10768	SGA-M16x1,5



Accessories – Ordering data

	For size	Stroke [mm]	Part No.	Type
23 Guide unit for fixed strokes, with recirculating ball bearing guide Technical data online: → feng				
	32	100	34494	FENG-32-100-KF
		200	34496	FENG-32-200-KF
		320	34497	FENG-32-320-KF
		400	150290	FENG-32-400-KF
		500	34498	FENG-32-500-KF
	40	100	34500	FENG-40-100-KF
		200	34502	FENG-40-200-KF
		320	34504	FENG-40-320-KF
		400	150291	FENG-40-400-KF
		500	34505	FENG-40-500-KF
	63	100	34514	FENG-63-100-KF
		200	34516	FENG-63-200-KF
		320	34518	FENG-63-320-KF
		400	34519	FENG-63-400-KF
		500	34520	FENG-63-500-KF

	For size	Stroke [mm]	Part No.	Type
23 Guide unit for variable strokes, with recirculating ball bearing guide Technical data online: → feng				
	32	10 ... 500	34487	FENG-32-...-KF
	40	10 ... 500	34488	FENG-40-...-KF
	63	10 ... 500	34490	FENG-63-...-KF
With plain-bearing guide Technical data online: → feng				
	32	10 ... 500	34481	FENG-32-...
	40	10 ... 500	34482	FENG-40-...
	63	10 ... 500	34484	FENG-63-...
23 Mounting kit for SMT-/SME-8, in combination with guide unit FENG Technical data online: → smb				
	32, 40		175705	SMB-8-FENG-32/40
	63		175706	SMB-8-FENG-50/63

3

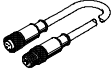
	Part No.	Type
24 Proximity sensor for T-slot, in combination with motor unit MTR-DCI		
	Magneto-resistive – N/O contact Technical data → 737	
	PNP, plug	★ 574334 SMT-8M-A-PS-24V-E-0,3-M8D
In combination with servo motor EMMS-AS, stepper motor EMMS-ST or guide unit FENG		
	Magneto-resistive – N/O contact Technical data → 737	
	PNP, cable	★ 574335 SMT-8M-A-PS-24V-E-2,5-OE
	Magnetic reed – N/O contact Technical data → 732	
	Cable	★ 543862 SME-8M-DS-24V-K-2,5-OE
	Cable	★ 543863 SME-8M-DS-24V-K-5,0-OE
	Technical data → 734	
	Cable	★ 150855 SME-8-K-LED-24

	For size	Part No.	Type
24 Connecting cable, straight socket Technical data → 949			
	0.5 m	★ 541346	NEBU-M8G3-K-0.5-M8G3
	1 m	★ 541347	NEBU-M8G3-K-1-M8G3
	2.5 m	★ 541348	NEBU-M8G3-K-2.5-M8G3
	5 m	★ 541349	NEBU-M8G3-K-5-M8G3
25 Slot cover¹⁾			
	32, 40, 63	151681	ABP-5-S

1) Packaging unit 2x 0.5 m.

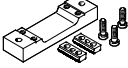
	For size	Part No.	Type
28 Profile mounting Dimensions online: → dnce			
	32	★ 1098473	EAHF-V1-32-P
	40	★ 1098478	EAHF-V1-40-P
	63	★ 1098481	EAHF-V1-63-P

	For size	Part No.	Type
29 Compensating component			
	32	570305	EADC-V1-32
	40	570306	EADC-V1-40
	63	570307	EADC-V1-50/63

Electric cylinders DNCE, with spindle drive

Accessories – Ordering data

3

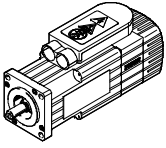
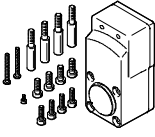
Motor/motor unit	Parallel kit	
		
	<ul style="list-style-type: none"> Space-saving gravity die-cast housing 	
	Part No.	Type
26 Permissible axis/motor combination with parallel kit – Technical data online: → eamm-u		
DNCE-32		
With servo motor		
EMMS-AS-40-...	★ 543150	EAMM-U-D32-40A
With motor unit²⁾		
MTR-DCI-32S-...	543152	EAMM-U-D32-32B
DNCE-40		
With servo motor		
EMMS-AS-55-...	★ 543157	EAMM-U-D40-55A
With motor unit²⁾		
MTR-DCI-42S-...-G7	543159	EAMM-U-D40-42B
MTR-DCI-42S-...-G14	543160	EAMM-U-D40-42C
DNCE-63		
With servo motor		
EMMS-AS-70-...	★ 543165	EAMM-U-D60-70A
With motor unit²⁾		
MTR-DCI-52S-...-G7	543167	EAMM-U-D60-52B
MTR-DCI-52S-...-G14	543168	EAMM-U-D60-52C

2) Order code for motor unit → .435

Note

Depending on the combination of motor/motor unit and electric cylinder, it may not be possible to reach the maximum feed force of the cylinder. The respective no-load driving torque of the kit must be taken into consideration when using parallel kits.

The following tool is available for sizing:
 PositioningDrives
 sizing software
 → www.festo.com

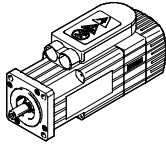
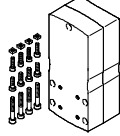
Motor/motor unit	Parallel kit	
		
	<ul style="list-style-type: none"> Increased housing rigidity More flexible motor mounting possible Optionally with protection class IP65 Use in combination with third-party motors on request 	
	Part No.	Type
26 Permissible axis/motor combination with parallel kit – Technical data online: → eamm-u		
DNCE-32		
With servo motor		
EMMS-AS-40-...	★ 1201591	EAMM-U-50-D32-40A-78
	★ 1202302	EAMM-U-50-D32-40A-78-S1 ¹⁾
EMMS-AS-55-...	★ 1210126	EAMM-U-60-D32-55A-91
	★ 1210450	EAMM-U-60-D32-55A-91-S1 ¹⁾
With stepper motor		
EMMS-ST-42-...	★ 1201607	EAMM-U-50-D32-42A-78
	★ 1202312	EAMM-U-50-D32-42A-78-S1 ¹⁾
EMMS-ST-57-...	★ 1210419	EAMM-U-60-D32-57A-91
	★ 1210453	EAMM-U-60-D32-57A-91-S1 ¹⁾
With motor unit²⁾		
MTR-DCI-32S-...	1570862	EAMM-U-50-D32-32B-78
MTR-DCI-42S-...	1577393	EAMM-U-60-D32-42B/C-91
	1577380	EAMM-U-60-D32-42B/C-91-S1 ¹⁾
With gear unit		
EMGA-40-P-...	1577358	EAMM-U-60-D32-40G-91
	1577346	EAMM-U-60-D32-40G-91-S1 ¹⁾

1) With protection class IP65.

2) Order code for motor unit → .435

Accessories – Ordering data

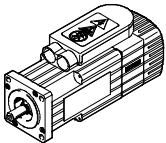
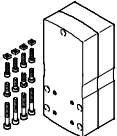
Motor/motor unit	Parallel kit	
		
	Part No.	Type
DNCE-40		
With servo motor		
EMMS-AS-55-...	★ 1210438	EAMM-U-60-D40-55A-91
	★ 1210458	EAMM-U-60-D40-55A-91-S1 ¹⁾
EMMS-AS-70-...	★ 1212826	EAMM-U-86-D40-70A-102
	★ 1212854	EAMM-U-86-D40-70A-102-S1 ¹⁾
With stepper motor		
EMMS-ST-57-...	★ 1210442	EAMM-U-60-D40-57A-91
	★ 1210462	EAMM-U-60-D40-57A-91-S1 ¹⁾
EMMS-ST-87-...	★ 1215802	EAMM-U-86-D40-87A-102
	★ 1215814	EAMM-U-86-D40-87A-102-S1 ¹⁾
With motor unit²⁾		
MTR-DCI-42S-...	1570950	EAMM-U-60-D40-42B/C-91
	1430735	EAMM-U-60-D40-42B/C-91-S1 ¹⁾
MTR-DCI-52S-...	1537046	EAMM-U-86-D40-52B/C-102
	1537011	EAMM-U-86-D40-52B/C-102-S1 ¹⁾
With gear unit		
EMGA-40-P-...	1577165	EAMM-U-60-D40-40G-91
	1435968	EAMM-U-60-D40-40G-91-S1 ¹⁾
EMGA-60-P-...	1586445	EAMM-U-86-D40-60G-102
	1586429	EAMM-U-86-D40-60G-102-S1 ¹⁾
EMGC-60-P-...	1586496	EAMM-U-86-D40-60H-102
	1586372	EAMM-U-86-D40-60H-102-S1 ¹⁾

1) With protection class IP65.

2) Order code for motor unit → 435

Note

Depending on the combination of motor/motor unit and electric cylinder, it may not be possible to reach the maximum feed force of the cylinder.

The respective no-load driving torque of the kit must be taken into consideration when using parallel kits.

The following tool is available for sizing:

PositioningDrives

sizing software

→ www.festo.com

The clamping component EADT is required to adjust the toothed belt pretension with EAMM-U-110.

The motor and/or axis shaft can optionally be supported with a counter bearing EAMG.

More information → [eamm-u](#)

	Part No.	Type
DNCE-63		
With servo motor		
EMMS-AS-70-...	★ 1212477	EAMM-U-86-D60-70A-102
	★ 1212835	EAMM-U-86-D60-70A-102-S1 ¹⁾
EMMS-AS-100-...	★ 1202436	EAMM-U-110-D60-100A-120
	★ 1203112	EAMM-U-110-D60-100A-120-S1 ¹⁾
With stepper motor		
EMMS-ST-87-...	★ 1215784	EAMM-U-86-D60-87A-102
	★ 1215810	EAMM-U-86-D60-87A-102-S1 ¹⁾
With motor unit²⁾		
MTR-DCI-52S-...	1537000	EAMM-U-86-D60-52B/C-102
	1431381	EAMM-U-86-D60-52B/C-102-S1 ¹⁾
MTR-DCI-62S-...	1536988	EAMM-U-110-D60-62B-120
	1431443	EAMM-U-110-D60-62B-120-S1 ¹⁾
With gear unit		
EMGA-60-P-...	1586347	EAMM-U-86-D60-60G-102
	1437163	EAMM-U-86-D60-60G-102-S1 ¹⁾
EMGC-60-P-...	1586276	EAMM-U-86-D60-60H-102
	1530837	EAMM-U-86-D60-60H-102-S1 ¹⁾
EMGA-60-P-...	1543240	EAMM-U-110-D60-60G-120
	1436183	EAMM-U-110-D60-60G-120-S1 ¹⁾
EMGC-60-P-...	1542264	EAMM-U-110-D60-60H-120
	1530621	EAMM-U-110-D60-60H-120-S1 ¹⁾
EMGA-80-P-...	1532949	EAMM-U-110-D60-80G-120
	1530875	EAMM-U-110-D60-80G-120-S1 ¹⁾

1) With protection class IP65.

2) Order code for motor unit → 435

Electric cylinders DNCE, with spindle drive

Accessories – Ordering data

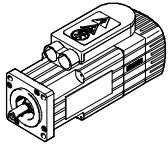
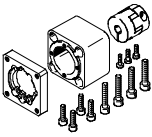
Motor/motor unit	Axial kit	
		
	Part No.	Type
27 Permissible axis/motor combination with axial kit – Technical data online: → eamm-a		
DNCE-32		
With servo motor		
EMMS-AS-40-...	★	543147 EAMM-A-D32-40A
	★	1322178 EAMM-A-D32A-40A-S1 ¹⁾
EMMS-AS-55-...	★	550979 EAMM-A-D32-55A
	★	1322180 EAMM-A-D32A-55A-S1 ¹⁾
With stepper motor		
EMMS-ST-42-...	★	543148 EAMM-A-D32-42A
	★	1322179 EAMM-A-D32A-42A-S1 ¹⁾
EMMS-ST-57-...	★	550980 EAMM-A-D32-57A
	★	1322181 EAMM-A-D32A-57A-S1 ¹⁾
With motor unit²⁾		
MTR-DCI-32S-... ³⁾	★	543149 EAMM-A-D32-32B
DNCE-40		
With servo motor		
EMMS-AS-55-...	★	543153 EAMM-A-D40-55A
	★	1322182 EAMM-A-D40A-55A-S1 ¹⁾
EMMS-AS-70-...	★	550981 EAMM-A-D40-70A
	★	1322185 EAMM-A-D40A-70A-S1 ¹⁾
With servo motor and gear unit		
EMMS-AS-40-...		560282 EAMM-A-D40-40G
EMGA-40-P-G...-SAS-40		
With stepper motor		
EMMS-ST-57-...	★	543154 EAMM-A-D40-57A
	★	1322183 EAMM-A-D40A-57A-S1 ¹⁾
EMMS-ST-87-...	★	550982 EAMM-A-D40-87A
	★	1322186 EAMM-A-D40A-87A-S1 ¹⁾
With motor unit²⁾		
MTR-DCI-42S-...-G7 ³⁾	★	543155 EAMM-A-D40-42B
MTR-DCI-42S-...-G14 ³⁾	★	543156 EAMM-A-D40-42C

1) With protection class IP65.
 2) Order code for motor unit →.435
 3) Only in combination with DNCE-...-LS.

	Part No.	Type
DNCE-63		
With servo motor		
EMMS-AS-70-...	★	543161 EAMM-A-D60-70A
	★	1322187 EAMM-A-D60A-70A-S1 ¹⁾
EMMS-AS-100-...	★	550983 EAMM-A-D60-100A
	★	1322190 EAMM-A-D60A-100A-S1 ¹⁾
With servo motor and gear unit		
EMMS-AS-55-...		560283 EAMM-A-D60-60G
EMGA-60-P-G...-SAS-55		
EMMS-AS-70-...		560283 EAMM-A-D60-60G
EMGA-60-P-G...-SAS-70		
With stepper motor		
EMMS-ST-87-...	★	543162 EAMM-A-D60-87A
	★	1322188 EAMM-A-D60A-87A-S1 ¹⁾
With stepper motor and gear unit		
EMMS-ST-57-...		560283 EAMM-A-D60-60G
EMGA-60-P-G...-SST-57		
With motor unit²⁾		
MTR-DCI-52S-...-G7 ³⁾	★	543163 EAMM-A-D60-52B
MTR-DCI-52S-...-G14 ³⁾	★	543164 EAMM-A-D60-52C

1) With protection class IP65.
 2) Order code for motor unit →.435
 3) Only in combination with DNCE-...-LS.

Note

Depending on the combination of motor/motor unit and electric cylinder, it may not be possible to reach the maximum feed force of the cylinder.

The following tool is available for sizing:
 PositioningDrives
 sizing software
 → www.festo.com

Dimensions

Download CAD data → www.festo.com

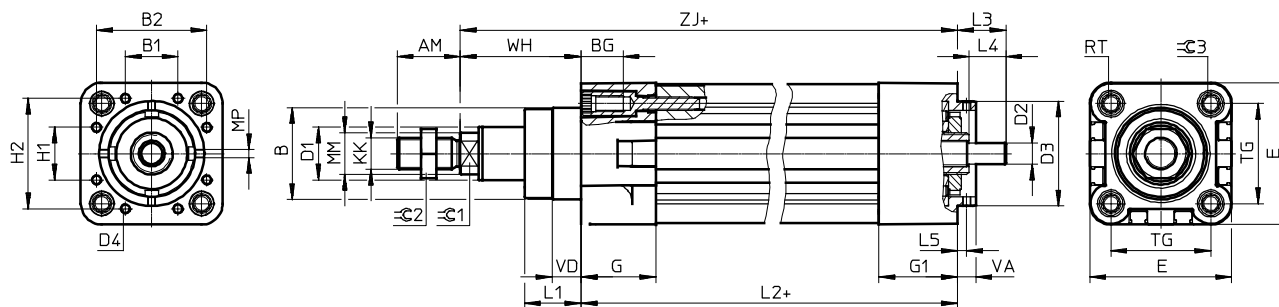

+ = plus stroke length

Size	AM	B ∅ d11	B1	B2	BG	D1 ∅ h9	D2 ∅ h6	D3 ∅ f7	D4	E	G	G1	H1	H2	KK
32	22	30	19	32	16	16	6	32	M3	45.5	24	26	19	32	M10x1.25
40	24	35	20	42	16	20	8	40	M4	54	28.5	30	20	42	M12x1.25
63	32	45	31	62	17	28	12	60	M5	75.5	34	36	31	62	M16x1.5

Size	L1	L2	L3	∅CL4	L5	MM	MP	RT	TG	VA	VD +1/-0.7	WH	ZJ ±1	∅C1	∅C2	∅C3
32	18	122	15.9	8	3.5	12	M3	M6	32.5	7	10	26	148	10	17	6
40	21.5	146.5	18.4	14	3.5	16	M3	M6	38	7	10.5	30	176.5	13	19	6
63	28.5	177	23.5	17	4.5	20	M4	M8	56.5	9	15	37	214	17	24	8

Spindle axes EGC-BS-KF, with recirculating ball bearing guide

3



- High speeds and feed forces
- Recirculating ball bearing guide and rigid profile
- Large loads and torques
- Spare parts service

→ www.festo.com/catalogue/egc-bs

Product range overview

Type/version	Size	Stroke [mm]	Feed force [N]	Product options				→ Page/online
				S	ML	MR	GK	
EGC-BS								
KF – Recirculating ball bearing guide	70, 80, 120, 185	50 ... 3,000	300 ... 3,000	■	■	■	■	325
EGC-FA								
Passive guide axis	70, 80, 120, 185	50 ... 8,500	–	–	–	–	■	egc-fa

Product options

S Spindle support	GQ Extended slide, protected	M1 Displacement encoder (resolution: 2.5 µm)	1HR Clamping unit, 1-channel, on right
ML Motor on left	KL Additional slide on left	M2 Displacement encoder (resolution: 10 µm)	2H Clamping unit, 2-channel
MR Motor on right	KR Additional slide on right	1HL Clamping unit, 1-channel, on left	PN Pneumatically actuated clamping unit
GK Standard slide	C Lubrication adapter		
GV Extended slide			
GP Standard slide, protected			

At a glance

- | | | | |
|--|---|--|---|
| <p>Powerful</p> <ul style="list-style-type: none"> • Generously sized profiles with an optimised cross section afford maximum rigidity and load capacity • Speed, acceleration and torque resistance set a new standard | <p>Economical</p> <ul style="list-style-type: none"> • In addition to its technical data, the spindle axis also offers an excellent price/performance ratio • Due to the EGC's high performance it is often possible to use a smaller size | <p>Versatile</p> <ul style="list-style-type: none"> • Different spindle pitches, numerous sizes and variants such as protected guides open up a broad range of applications • Space-saving position sensing with proximity sensor in the profile slot is possible | <ul style="list-style-type: none"> • Wide range of options for mounting on drives • Comprehensive range of mounting accessories for multi-axis combinations • Spindle support enables maximum travel speed with all stroke lengths |
|--|---|--|---|

Spindle axes EGC-BS-KF, with recirculating ball bearing guide

FESTO

Technical data

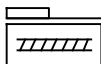

3

Technical data

Dimensions → 330

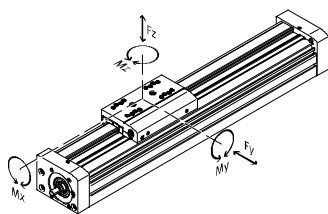

Note

PositioningDrives
sizing software→ www.festo.com

Size	70	80	120	185
Spindle pitch	[mm/rev.]	10	10 20	10 25 40
Working stroke ¹⁾	[mm]	50 ... 1,000	50 ... 2,000	50 ... 2,500 50 ... 3,000
Max. feed force F_x	[N]	300	600	1,300 3,000
No-load torque	[Nm]	0.3	0.5 0.5	1.5 1.5 3.0
at min. travel speed	[m/s]	0.05	0.1 0.1	0.2 0.2 0.2
No-load torque	[Nm]	0.45	0.75 0.75	2.25 2.25 6.5
at max. travel speed	[m/s]	0.5	0.5 1	0.6 1.5 2
Max. radial force ²⁾	[N]	220	250	500 4,000
Max. rotational speed ³⁾	[rpm]	3,000	3,000	3,600 3,000
Max. acceleration	[m/s ²]	15		
Repetition accuracy	[mm]	±0.02		
Max. permissible force F_y	[N]	1,850	3,050	6,890 15,200
Max. permissible force F_z	[N]	1,850	3,050	6,890 15,200
Max. permissible torque M_x	[Nm]	16	36	144 529
Max. permissible torque M_y	[Nm]	51	97	380 1,157
Max. permissible torque M_z	[Nm]	51	97	380 1,157

- 1) Total stroke = working stroke + 2x stroke reserve.
- 2) At the drive shaft.
- 3) Rotational speed and speed are stroke-dependent.

Operating conditions

Ambient temperature ⁴⁾	[°C]	-10 ... +60
Protection class		IP40

4) Note operating range of proximity sensors.

Spindle

Size	70	80	120	185
Diameter	[mm]	12	15	25 40
Pitch	[mm/rev.]	10	10 20	10 25 40

Mass moment of inertia

Size	70	80	120	185
Spindle pitch		10	10 20	10 25 40
J_0	[kg mm ²]	1.99	5.2 5.2	64.46 64.46 594
J_S per metre stroke	[kg mm ² /m]	14.2	34.6 34.6	275.6 275.6 1803.1
J_L per kg effective load	[kg mm ² /kg]	2.53	2.53 10.13	2.53 15.83 40.53
J_W Slide	[kg mm ²]	1.04	1.86 7.46	6.09 38.06 348.87

The mass moment of inertia J_A of the entire axis is calculated as follows:

$$J_A = J_0 + J_W + J_S \times \text{working stroke [m]} + J_L \times m_{\text{effective load [kg]}}$$

Spindle axes EGC-BS-KF, with recirculating ball bearing guide

Technical data

Materials	
End cap	Anodised wrought aluminium alloy
Moment compensator	Anodised wrought aluminium alloy
Profile	Anodised wrought aluminium alloy
Slide	Anodised wrought aluminium alloy
Spindle	Steel
Guide rail	High-alloy steel
Cover strip	Polyurethane

Order code

Type		Size		Drive function		Spindle pitch		Spindle support		Guide		Stroke reserve		Motor attachment position		Slide	
EGC	Electromechanical linear axis			BS	Ball screw			-	None	KF	Recirculating ball bearing guide	...H	0 ... 999 (0 = no stroke reserve)	ML	Left	GK	Standard slide
		Stroke [mm]				10P	10 mm/rev	1						MR	Right		
		70	100; 200; 300; 400; 500; 600; 700; 800; 1,000	50 ... 1,000		20P	20 mm/rev	2	S	With spindle support							
		80	100; 200; 300; 500; 600; 800; 1,000; 1,400; 1,500; 1,800; 2,000	50 ... 2,000		25P	25 mm/rev	3									
		120	200; 300; 500; 600; 800; 1,000; 1,400; 1,500; 2,000; 2,500	50 ... 2,500		40P	40 mm/rev	4									
		185	300; 500; 600; 1,000; 1,500; 2,000; 2,500; 3,000	50 ... 3,000													

1 Only with size 70, 80, 120.

2 Only with size 80.

3 Only with size 120.

4 Only with size 185.

5 Only above stroke 705 mm with size 70, only above stroke 780 mm with size 80, only above stroke 883 mm with size 120, only above stroke 1,224 mm with size 185

6 The sum of the stroke length and 2x stroke reserve must not exceed the maximum working stroke.

Spindle axes EGC-BS-KF, with recirculating ball bearing guide

Ordering – Product options

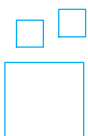

Configurable product

This product and all its options can be ordered using the configurator.

The configurator can be found under Products on the DVD or
www.festo.com/catalogue/...

Enter the type code in the search field.

Accessories

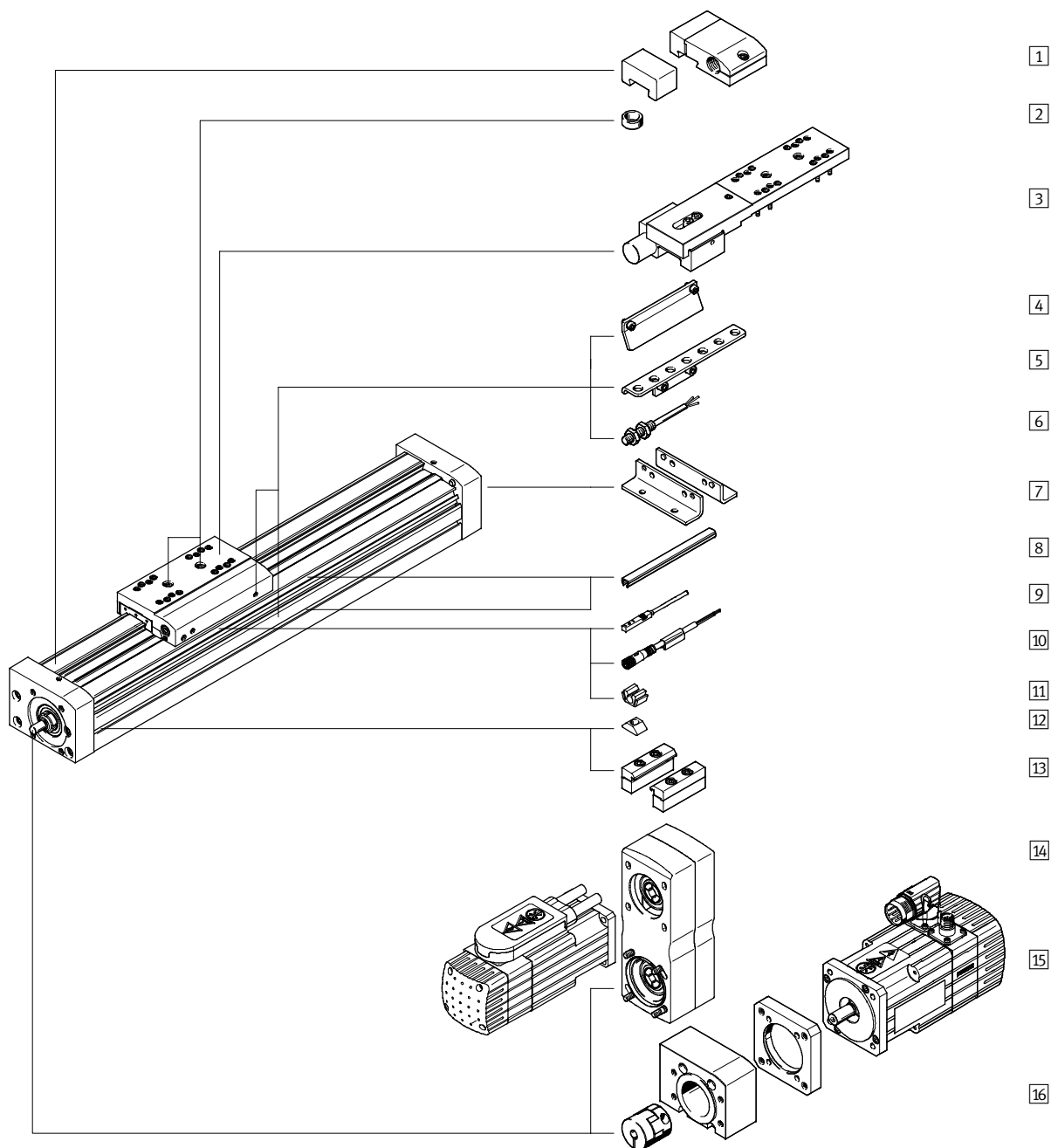





		→ Page/online
1	Emergency buffer NPE/shock absorber retainer KYE	328
2	Centring pin ZBS/centring sleeve ZBH	328
3	Clamping unit 1H...-PN, 2H-PN	egc-bs
4	Switch lug SF-EGC	328
5	Sensor bracket HWS-EGC	328
6	Inductive proximity sensor SIEN	328
7	Foot mounting HPE	328
8	Slot cover ABP/ABP-S	328

		→ Page/online
9	Inductive proximity sensor SIES	328
10	Connecting cable NEBU	328
11	Clip SMBK	328
12	Slot nut NST	328
13	Profile mounting MUE	328
14	Parallel kit EAMM-U	329
15	Motor EMMS	329
16	Axial kit EAMM-A	329

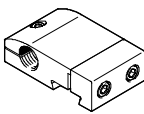
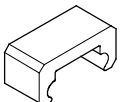
Spindle axes EGC-BS-KF, with recirculating ball bearing guide

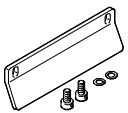
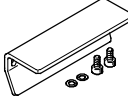

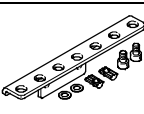
Accessories – Ordering data

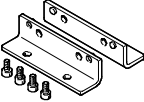
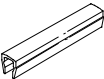
	For size	Part No.	Type
1 Shock absorber retainer Dimensions online: → egc-bs			
	70	557584	KYE-70
	80	557585	KYE-80
	120	557586	KYE-120
	185	557587	KYE-185
1 Emergency buffer			
	70	562581	NPE-70
	80	562582	NPE-80
	120	562583	NPE-120
	185	562584	NPE-185
2 Centring pin¹⁾²⁾ Technical data online: → zbs			
	70	150928	ZBS-5
2 Centring sleeve¹⁾²⁾ Technical data online: → zbh			
	80, 120, 185	150927	ZBH-9
4 Switch lug³⁾ Dimensions online: → egc-bs			
	70	558047	SF-EGC-1-70
	80	558048	SF-EGC-1-80
	120	558049	SF-EGC-1-120
	185	558051	SF-EGC-1-185
4 Switch lug⁴⁾ Dimensions online: → egc-bs			
	70	558052	SF-EGC-2-70
	80	558053	SF-EGC-2-80
	120	558054	SF-EGC-2-120
	185	558056	SF-EGC-2-185

	For size	Part No.	Type
5 Sensor bracket⁵⁾ Dimensions online: → egc-bs			
	70	558057	HWS-EGC-M5
	80	558057	HWS-EGC-M5
	120	570365	HWS-EGC-M8-B
	185	560517	HWS-EGC-M8-KURZ
6 Inductive proximity sensor, N/O contact, M8 Technical data → 755			
	PNP, cable	★ 150386	SIEN-M8B-PS-K-L
	PNP, plug	★ 150387	SIEN-M8B-PS-S-L
N/C contact, M8 Technical data → 755			
	PNP, cable	150390	SIEN-M8B-PO-K-L
	PNP, plug	150391	SIEN-M8B-PO-S-L
7 Foot mounting Dimensions online: → egc-bs			
	70	558321	HPE-70
	80	558322	HPE-80
	120	558323	HPE-120
	185	558325	HPE-185
8 Slot cover⁶⁾			
	For mounting slot		
	70, 80	151681	ABP-5
	120, 185	151682	ABP-8
	For sensor slot		
	70 ... 185	563360	ABP-5-S1

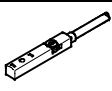
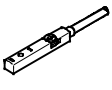
- 1) Packaging unit 10 pieces.
- 2) 2 centring pins/sleeves included in the scope of delivery of the axis.
- 3) For sensing via proximity sensor SIES-8M.
- 4) For sensing via proximity sensor SIEN-M8B or SIES-8M.
- 5) For proximity sensor SIEN-M8B.
- 6) Packaging unit 2x 0.5 m.

	Part No.	Type
9 Proximity sensor for T-slot, inductive, N/O contact Technical data → 759		
	PNP, cable	551386 SIES-8M-PS-24V-K-7,5-OE
	PNP, plug	551387 SIES-8M-PS-24V-K-0,3-M8D
	NPN, cable	551396 SIES-8M-NS-24V-K-7,5-OE
	NPN, plug	551397 SIES-8M-NS-24V-K-0,3-M8D
N/C contact Technical data → 759		
	PNP, cable	551391 SIES-8M-PO-24V-K-7,5-OE
	PNP, plug	551392 SIES-8M-PO-24V-K-0,3-M8D
	NPN, cable	551401 SIES-8M-NO-24V-K-7,5-OE
	NPN, plug	551402 SIES-8M-NO-24V-K-0,3-M8D

	For size	Part No.	Type
10 Connecting cable, straight socket Technical data → 949			
	2.5 m	★ 541333	NEBU-M8G3-K-2.5-LE3
	5 m	★ 541334	NEBU-M8G3-K-5-LE3
Angled socket Technical data → 949			
	2.5 m	★ 541338	NEBU-M8W3-K-2.5-LE3
	5 m	★ 541341	NEBU-M8W3-K-5-LE3
11 Clip			
	70 ... 185	534254	SMBK-8

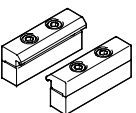
	For size	Part No.	Type
12 Slot nut Dimensions online: → nst			
	70, 80	150914	NST-5-M5
	120, 185	150915	NST-8-M6
13 Profile mounting Dimensions online: → egc-bs			
	70	★ 558043	MUE-70/80
	80	★ 558043	MUE-70/80
	120	558044	MUE-120/185
	185	558044	MUE-120/185

Accessories – Ordering data

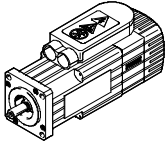
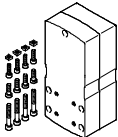
Motor	Parallel kit	
		
	Part No.	Type
[14]/[15] Permissible axis/motor combination with parallel kit –		
Technical data online: → eamm-u		
EGC-70		
With servo motor		
EMMS-AS-40-...	1217708	EAMM-U-50-S38-40A-78
EMMS-AS-55-...	1218538	EAMM-U-60-S38-55A-91
With stepper motor		
EMMS-ST-42-...	1217945	EAMM-U-50-S38-42A-78
EMMS-ST-57-...	1218568	EAMM-U-60-S38-57A-91
EGC-80		
With servo motor		
EMMS-AS-55-...	1219370	EAMM-U-60-S48-55A-91 ¹⁾
EMMS-AS-70-...	1217689	EAMM-U-86-S48-70A-102 ¹⁾
With stepper motor		
EMMS-ST-57-...	1219379	EAMM-U-60-S48-57A-91 ¹⁾
EMMS-ST-87-...	1217604	EAMM-U-86-S48-87A-177 ¹⁾
With gear unit		
EMGA-60-P-...	1587251	EAMM-U-86-S48-60G-102 ¹⁾
EMGC-60-P-...	1587338	EAMM-U-86-S48-60H-102 ¹⁾
EGC-120		
With servo motor		
EMMS-AS-70-...	1217543	EAMM-U-86-S62-70A-177 ¹⁾
EMMS-AS-100-...	1217381	EAMM-U-110-S62-100A-207 ¹⁾
EMMS-AS-140-...	1219440	EAMM-U-145-S62-140A-288 ¹⁾
With stepper motor		
EMMS-ST-87-...	1217373	EAMM-U-86-S62-87A-177 ¹⁾
With gear unit		
EMGA-60-P-...	1587411	EAMM-U-86-S62-60G-177 ¹⁾
EMGC-60-P-...	1587453	EAMM-U-86-S62-60H-177 ¹⁾
EGC-185		
With servo motor		
EMMS-AS-100-...	1220656	EAMM-U-110-S95-100A-207 ¹⁾
EMMS-AS-140-...	1220582	EAMM-U-145-S95-140A-288 ¹⁾
With gear unit		
EMGA-80-P-...	1589544	EAMM-U-110-S95-80G-207 ¹⁾

Note

1) These parallel kits include a counter bearing EAMG for supporting the axis shaft. More information → [eamm-u](#)

Note

The clamping component EADT is required to adjust the toothed belt pretension with EAMM-U-110 and EAMM-U-145.

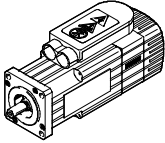
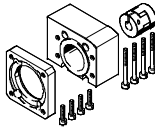
Motor	Axial kit	
		
	Part No.	Type
[15]/[16] Permissible axis/motor combination with axial kit –		
Technical data online: → eamm-a		
EGC-70		
With servo motor		
EMMS-AS-40-...	558162	EAMM-A-S38-40A
EMMS-AS-55-...	558163	EAMM-A-S38-55A
With stepper motor		
EMMS-ST-42-...	560685	EAMM-A-S38-42A
EMMS-ST-57-...	560686	EAMM-A-S38-57A
EGC-80		
With servo motor		
EMMS-AS-55-...	558164	EAMM-A-S48-55A
EMMS-AS-70-...	558165	EAMM-A-S48-70A
With stepper motor		
EMMS-ST-57-...	560687	EAMM-A-S48-57A
EMMS-ST-87-...	560688	EAMM-A-S48-87A
EGC-120		
With servo motor		
EMMS-AS-70-...	558166	EAMM-A-S62-70A
EMMS-AS-100-...	558167	EAMM-A-S62-100A
EMMS-AS-140-...	558168	EAMM-A-S62-140A
With stepper motor		
EMMS-ST-87-...	560689	EAMM-A-S62-87A
EGC-185		
With servo motor		
EMMS-AS-100-...	558169	EAMM-A-S95-100A
EMMS-AS-140-...	558170	EAMM-A-S95-140A

The motor and/or axis shaft can optionally be supported with a counter bearing EAMG. More information → [eamm-u](#)

Spindle axes EGC-BS-KF, with recirculating ball bearing guide

Dimensions

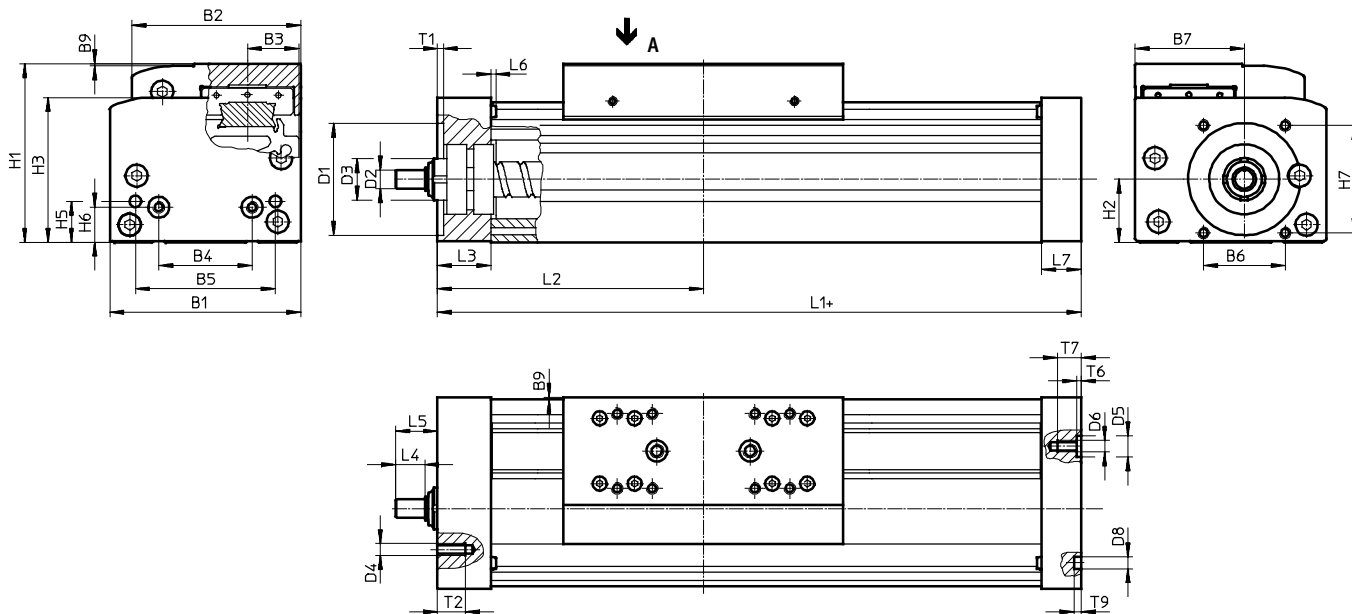

+ = plus stroke length + 2x stroke reserve

Note
To avoid distortion in the slide, the bearing surfaces of the attachments must maintain a minimum flatness of 0.01 mm.

Size	Stroke	B1	B2	B3	B4	B5	B6	B7	B9	D1 ∅ H7	D2 ∅ h7	D3
70	50 ... 1,000	69	58.6	16.5	30	45	29	39	1	38	6	≈C13
80	< 1,477	82	72.6	22	40	60	35	46.75	1	48	8	∅18
	> 1,477											
120	< 1,704	120	107	33	80	40	64	78	1	62	12	∅28
	> 1,704											
185	< 2,361	186	169	53	120	80	80	114	1	95	25	∅44
	> 2,361											

Size	Stroke	D4	D5 ∅ H7	D6	D8 ∅ H7	H1	H2	H3	H5	H6	H7	L1
70	50 ... 1,000	M5	–	M5	5	64	22.5	50.5	13	13	36	168
80	< 1,477	M5	9	M5	5	76.5	27	62	17.5	15	46	196
	> 1,477											236
120	< 1,704	M6	–	M8	9	111.5	42.5	89.5	22	22	54	309
	> 1,704											369
185	< 2,361	M8	–	M10	9	172.5	65.2	141.5	25	25	80	412
	> 2,361											512

Size	Stroke	L2	L3	L4	L5	L6	L7	T1	T2	T6	T7	T9
70	50 ... 1,000	86.5	21	8	14	1.8	16	2.5	12	–	10	3.1
80	< 1,477	101	23	12.5	18	2	17	2.5	12	2.1	10	3.1
	> 1,477	121										
120	< 1,704	156	33	17.5	25.5	2	30	3	15	–	16	2.1
	> 1,704	186										
185	< 2,361	209	43	23	30.5	2	37	3	20	–	20	2.1
	> 2,361	259										

Spindle axes EGC-BS-KF, with recirculating ball bearing guide

Dimensions

GK – Standard slide

Size 70

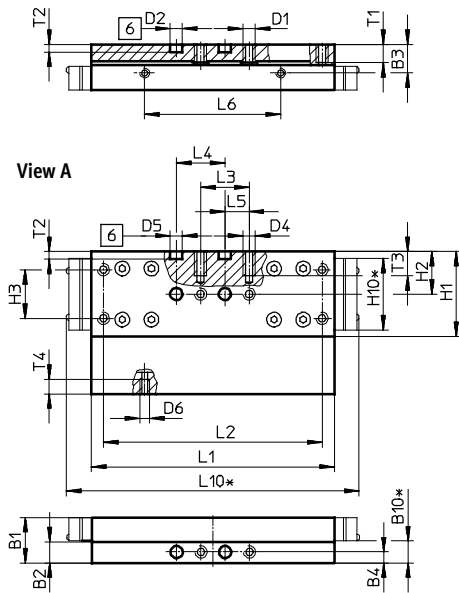

Size 80

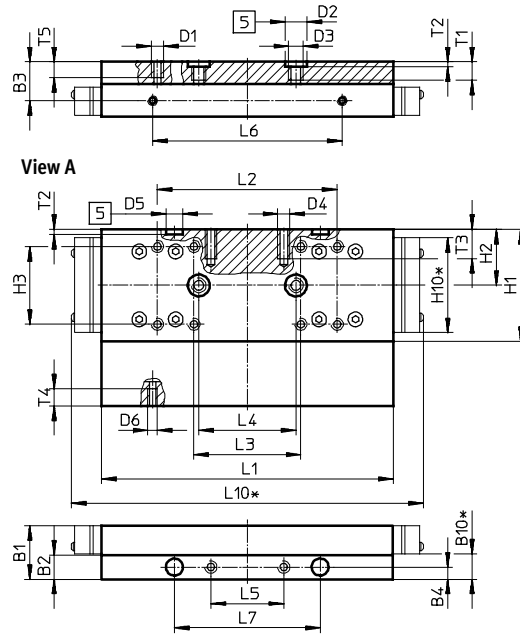

- 5 Hole for centring sleeve
- 6 Hole for centring pin
- * Protected version

Size	B1	B2	B3	B4	B10*	D1	D2 ∅ H7	D3	D4	D5 ∅ H7
70	18.7	8.7	11.7	4.5	9	M5	5	–	M5	5
80	22	10	16	5	10.4	M5	9	M6	M5	7

Size	D6	H1	H2	H3	H10*	L1 ±0.1	L2	L3	L4 ±0.03
70	M4	35	17.5	20 ±0.1	29.4	100	90 ±0.1	20 ±0.1	20
80	M4	46	23	32 ±0.2	39	120	74 ±0.2	44 ±0.2	40

Size	L5	L6 ±0.1	L7 ±0.05	L10*	T1	T2 ±0.01	T3	T4	T5
70	10 ±0.1	56	–	121	7.5	3.1	10	6	–
80	30 ±0.1	78	60	145	8.6	2.1	12	7	7.5

* Protected version

Spindle axes EGC-BS-KF, with recirculating ball bearing guide

Dimensions

GK – Standard slide

Size 120

3

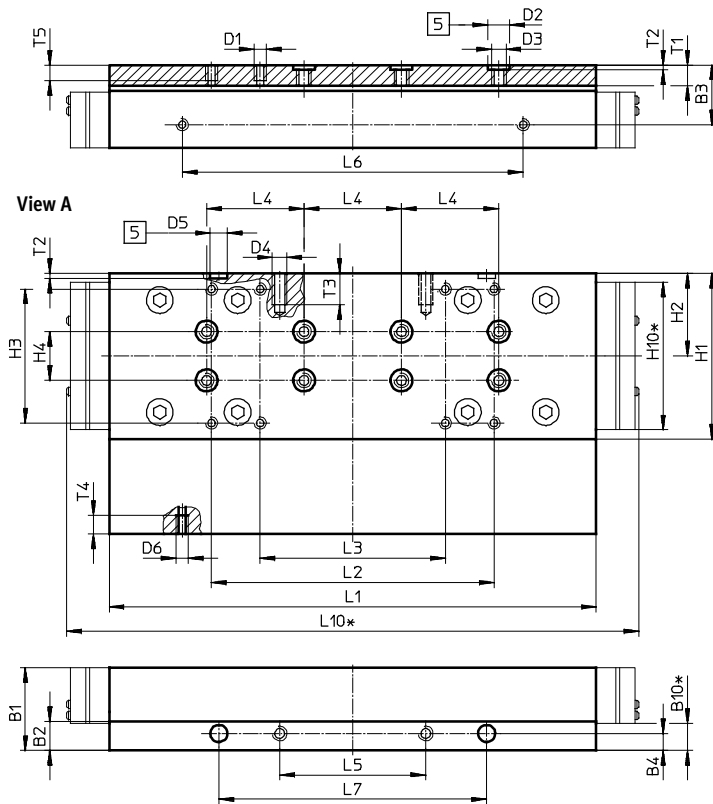

5 Hole for centring sleeve
* Protected version

Size	B1	B2	B3	B4	B10*	D1	D2 ∅ H7	D3	D4	D5 ∅ H7
120	34	12	24.5	7	11.2	M5	9	M6	M6	7

Size	D6	H1	H2	H3	H4	H10*	L1	L2	L3	L4
120	M5	68	34	55 ±0.2	20	60.6	203.3	116 ±0.2	76 ±0.2	40

Size	L5	L6	L7	L10*	T1	T2	T3	T4	T5
120	60 ±0.1	140	110	235	8.6	2.1	13	7.5	7.5

* Protected version

Spindle axes EGC-BS-KF, with recirculating ball bearing guide

Dimensions

GK – Standard slide

Size 185

3

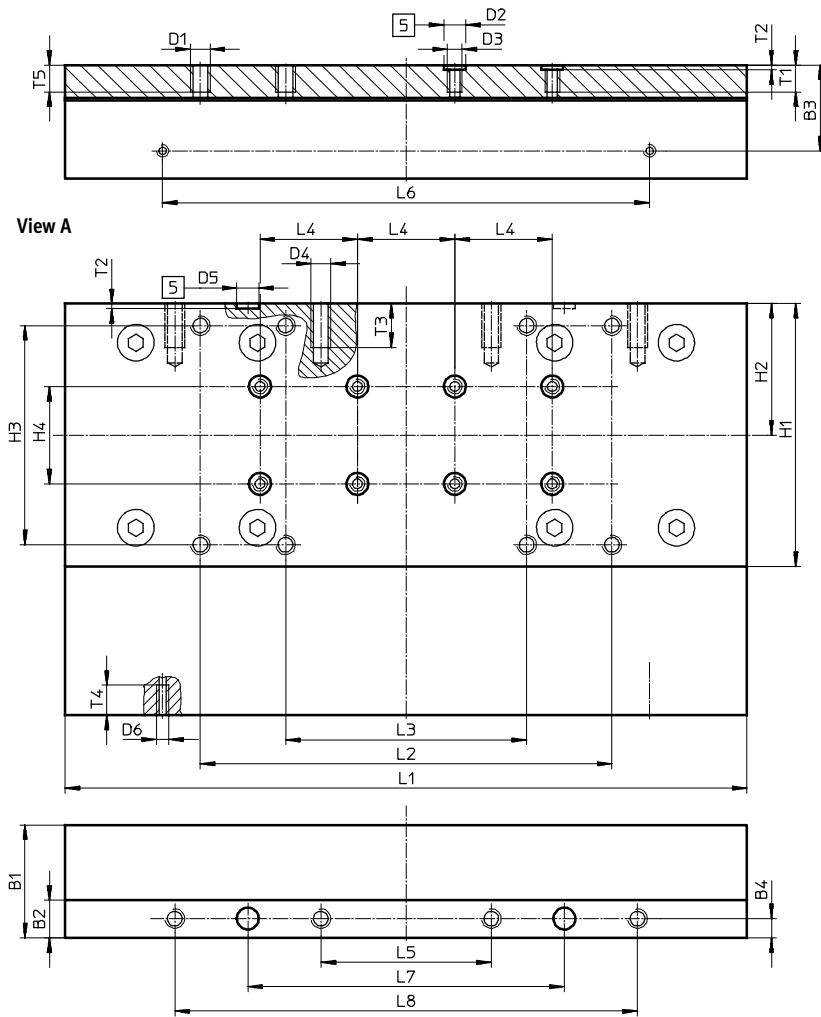

5 Hole for centring sleeve

Size	B1	B2	B3	B4	D1	D2 ∅ H7	D3	D4	D5 ∅ H7
185	46.5	15.5	35.2	8	M8	9	M6	M8	9

Size	D6	H1	H2	H3	H4	L1	L2	L3	L4
185	M5	108	54	90 ±0.2	40	282.8	169 ±0.2	99 ±0.2	40

Size	L5	L6	L7	L8	T1	T2	T3	T4	T5
185	70 ±0.2	200	130	190	11	2.1	18	12.3	12

Spindle axes EGC-HD-BS, with heavy-duty guide

3



- High speeds and feed forces
- Recirculating ball bearing guide and rigid profile
- Maximum loads and torques
- Ideal as a basic axis for linear gantries and cantilever axes
- Spare parts service

→ www.festo.com/catalogue/egc-hd-bs

Product range overview

Type/version	Size	Stroke [mm]	Feed force [N]	Product options	
				S	GK
EGC-HD-BS					
HD – Heavy-duty guide	125, 160, 220	50 ... 2,400	300 ... 1,300	■	■

Product options

- | | | | |
|----|---------------------------|----|---------------------------|
| S | Spindle support | KL | Additional slide on left |
| GK | Standard slide | KR | Additional slide on right |
| GP | Standard slide, protected | | |

At a glance

- | | | | |
|--|--|--|--|
| <p>Powerful</p> <ul style="list-style-type: none"> • New heavy-duty design for: <ul style="list-style-type: none"> – Maximum loads and torques – High feed forces and speeds – Long service life | <p>Economical</p> <ul style="list-style-type: none"> • In addition to its technical data, the spindle axis also offers an excellent price/performance ratio • Space-saving position sensing with proximity sensor in the profile slot is possible | <p>Versatile</p> <ul style="list-style-type: none"> • Precision, resilient DUO guide rail • Ideal as a basic axis for linear gantries and cantilever axes • The spindle axis with integrated ball screw combines high precision and flexible spindle pitches | <ul style="list-style-type: none"> • Wide range of options for mounting on drives • Spindle support enables maximum travel speed with all stroke lengths |
|--|--|--|--|

Technical data

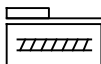

3

Technical data

Dimensions → 340

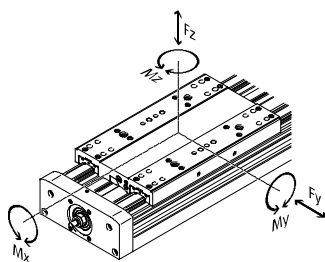

Note

PositioningDrives
sizing software

→ www.festo.com

Size	125	160	220	
Spindle pitch	[mm/rev.]	10	10 20	10 25
Working stroke ¹⁾	[mm]	50 ... 900	50 ... 1,900	50 ... 2,400
Max. feed force F_x	[N]	300	600	1,300
No-load torque	[Nm]	0.3	0.5 0.5	1.5 1.5
at min. travel speed	[m/s]	0.05	0.1 0.1	0.2 0.2
No-load torque	[Nm]	0.45	0.75 0.75	2.25 2.25
at max. travel speed	[m/s]	0.5	0.5 1	0.6 1.5
Max. radial force ²⁾	[N]	220	250	500
Max. rotational speed ³⁾	[rpm]	3,000	3,000	3,600
Max. acceleration	[m/s ²]	15		
Repetition accuracy	[mm]	±0.02		
Max. permissible force F_y	[N]	3,650	5,600	13,000
Max. permissible force F_z	[N]	3,650	5,600	13,000
Max. permissible torque M_x	[Nm]	140	300	900
Max. permissible torque M_y	[Nm]	275	500	1,450
Max. permissible torque M_z	[Nm]	275	500	1,450

- 1) Total stroke = working stroke + 2x stroke reserve.
- 2) At the drive shaft.
- 3) Rotational speed and speed are stroke-dependent.

Operating conditions

Ambient temperature ⁴⁾	[°C]	-10 ... +60
Protection class		IP40

4) Note operating range of proximity sensors.

Spindle

Size	125	160	220	
Diameter	[mm]	12	15	25
Pitch	[mm/rev.]	10	10 20	10 25

Mass moment of inertia

Size	125	160	220			
Spindle pitch		10	10 20	10 25		
J_0	[kg mm ²]	6.06	13.94	29.74	106.78	184.26
J_S per metre stroke	[kg mm ² /m]	14.2	34.6	34.6	275.6	275.6
J_L per kg effective load	[kg mm ² /kg]	2.53	2.53	10.13	2.53	15.83

The mass moment of inertia J_A of the entire axis is calculated as follows:

$$J_A = J_0 + J_S \times \text{working stroke [m]} + J_L \times m_{\text{effective load [kg]}}$$

Spindle axes EGC-HD-BS, with heavy-duty guide

Technical data

Materials	
End cap	Anodised wrought aluminium alloy
Slide	Anodised wrought aluminium alloy
Guide rail	Coated and corrosion-resistant steel
Spindle	Steel
Cover strip	Polyurethane

3

Order code

		EGC	-	HD	-		-		-	BS	-		-		-		-	GK	
Type																			
EGC	Electromechanical linear axis																		
Guide																			
HD	Heavy-duty guide																		
Size																			
	Stroke [mm]																		
125	100, 200, 300, 400, 500, 600, 700, 900	50 ... 900																	
160	100; 200; 400; 500; 700; 900; 1,300; 1,400; 1,700; 1,900	50 ... 1,900																	
220	100; 200; 400; 500; 700; 900; 1,300; 1,400; 1,900; 2,400	50 ... 2,400																	
Drive function																			
BS	Ball screw spindle																		
Spindle pitch																			
10P	10 mm/rev																		
20P	20 mm/rev	1																	
25P	25 mm/rev	2																	
Spindle support																			
S	With spindle support	3																	
Stroke reserve																			
...H	0 ... 999 (0 = no stroke reserve)	4																	
Slide																			
GK	Standard slide																		

- 1 Only with size 160.
- 2 Only with size 220.
- 3 Only above stroke 605 mm with size 125, only above stroke 680 mm with size 160, only above stroke 783 mm with size 220.
- 4 The sum of the stroke length and 2x stroke reserve must not exceed the maximum working stroke.

Ordering – Product options

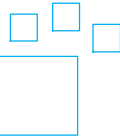
	<p>Configurable product</p>	<p>This product and all its options can be ordered using the configurator.</p>	<p>The configurator can be found under Products on the DVD or → www.festo.com/catalogue/...</p>
<p>Enter the type code in the search field.</p>			

Accessories

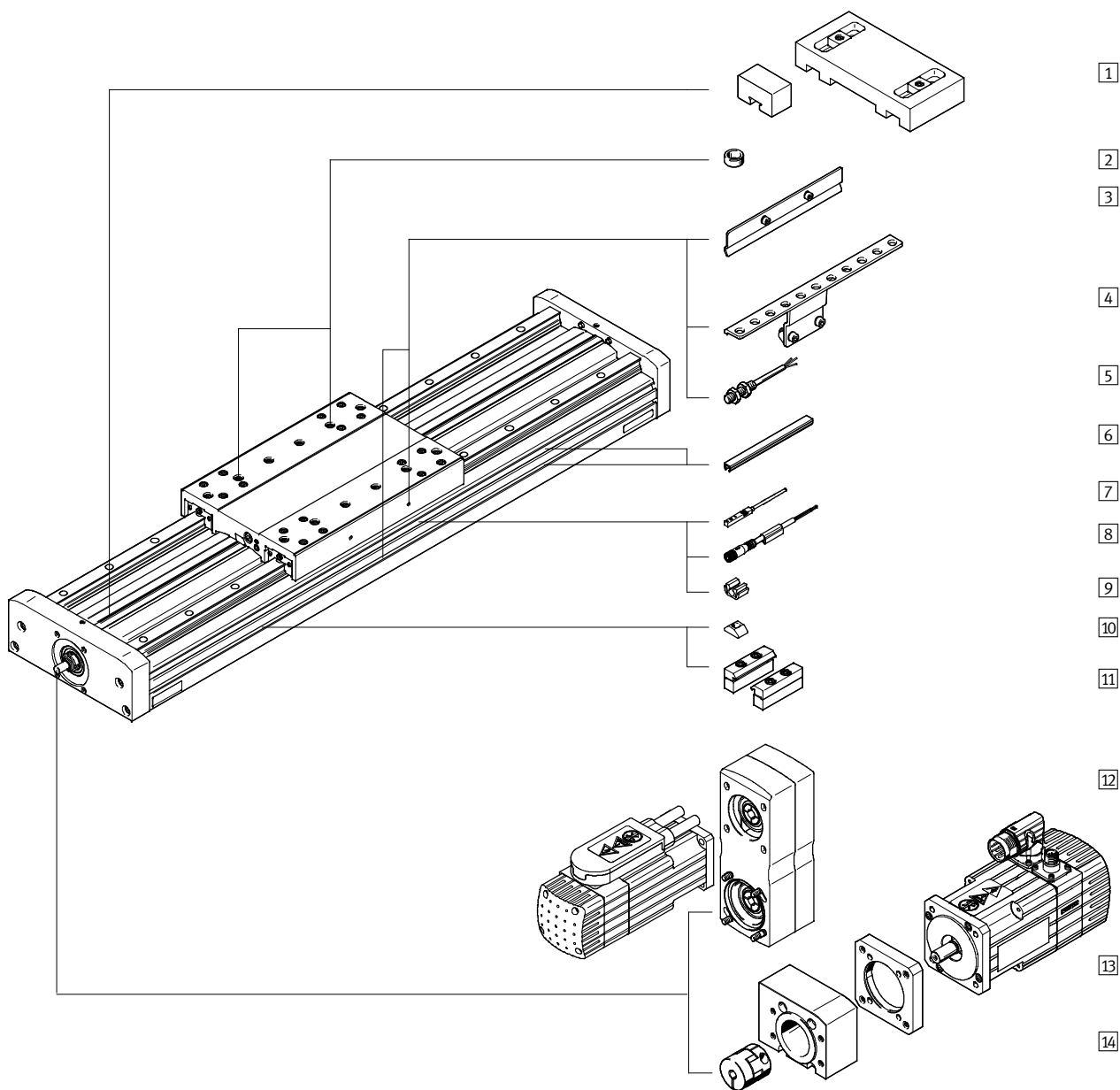







3

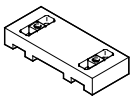

		→ Page/online
1	Emergency buffer NPE/retainer EAYH	338
2	Centring pin ZBS/centring sleeve ZBH	338
3	Switch lug SF-EGC	338
4	Sensor bracket HWS-EGC	338
5	Inductive proximity sensor SIEN	338
6	Slot cover ABP/ABP-S	338
7	Inductive proximity sensor SIES	338

		→ Page/online
8	Connecting cable NEBU	338
9	Clip SMBK	338
10	Slot nut NST	338
11	Profile mounting MUE	338
12	Parallel kit EAMM-U	339
13	Motor EMMS	339
14	Axial kit EAMM-A	339

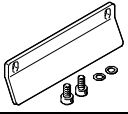
Spindle axes EGC-HD-BS, with heavy-duty guide

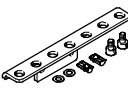
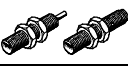

Accessories – Ordering data

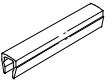
	For size	Part No.	Type
1 Retainer EAYH	Dimensions online: → egc-hd-bs		
	125	1662803	EAYH-L2-125-N
	160	1669259	EAYH-L2-160-N
	220	1669260	EAYH-L2-220-N
1 Emergency buffer	Technical data online: → zbs		
	125	1662475	NPE-125
	160	1672593	NPE-160
	220	1672598	NPE-220
2 Centring pin¹⁾²⁾	Technical data online: → zbs		
	125	150928	ZBS-5
2 Centring sleeve¹⁾²⁾	Technical data online: → zbs		
	125 ... 220	150927	ZBH-9
3 Switch lug³⁾	Dimensions online: → egc-hd-bs		
	125	570027	SF-EGC-HD-1-125
	160	1645872	SF-EGC-HD-1-160
	220	1645866	SF-EGC-HD-1-220
3 Switch lug⁴⁾	Dimensions online: → egc-hd-bs		
	125	570030	SF-EGC-HD-2-125
	160	1645865	SF-EGC-HD-2-160
	220	1645868	SF-EGC-HD-2-220

	For size	Part No.	Type
4 Sensor bracket⁵⁾	Dimensions online: → egc-hd-bs		
	125	558057	HWS-EGC-M5
	160	558057	HWS-EGC-M5
	220	570365	HWS-EGC-M8-B
5 Inductive proximity sensor, N/O contact, M8	Technical data → 755		
	PNP, cable	★ 150386	SIEN-M8B-PS-K-L
	PNP, plug	★ 150387	SIEN-M8B-PS-S-L
N/C contact, M8	Technical data → 755		
	PNP, cable	150390	SIEN-M8B-PO-K-L
	PNP, plug	150391	SIEN-M8B-PO-S-L
6 Slot cover⁶⁾	Technical data → 755		
	For mounting slot		
	125, 160 ⁷⁾	151681	ABP-5
	160 ⁸⁾ , 220	151682	ABP-8
	For sensor slot		
125 ... 220	563360	ABP-5-S1	

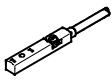
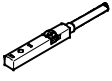
- 1) Packaging unit 10 pieces.
- 2) 2 centring pins/sleeves included in the scope of delivery of the axis.
- 3) For sensing via proximity sensor SIES-8M.
- 4) For sensing via proximity sensor SIEN-M8B or SIES-8M.
- 5) For proximity sensor SIEN-M8B.
- 6) Packaging unit 2x 0.5 m.
- 7) For mounting slot at side.
- 8) For mounting slot underneath.

	Part No.	Type
7 Proximity sensor for T-slot, inductive, N/O contact	Technical data → 759	
	PNP, cable	551386 SIES-8M-PS-24V-K-7,5-OE
	PNP, plug	551387 SIES-8M-PS-24V-K-0,3-M8D
	NPN, cable	551396 SIES-8M-NS-24V-K-7,5-OE
	NPN, plug	551397 SIES-8M-NS-24V-K-0,3-M8D
N/C contact	Technical data → 759	
	PNP, cable	551391 SIES-8M-PO-24V-K-7,5-OE
	PNP, plug	551392 SIES-8M-PO-24V-K-0,3-M8D
	NPN, cable	551401 SIES-8M-NO-24V-K-7,5-OE
	NPN, plug	551402 SIES-8M-NO-24V-K-0,3-M8D

	For size	Part No.	Type
8 Connecting cable, straight socket	Technical data → 949		
	2.5 m	★ 541333	NEBU-M8G3-K-2.5-LE3
	5 m	★ 541334	NEBU-M8G3-K-5-LE3
Angled socket	Technical data → 949		
	2.5 m	★ 541338	NEBU-M8W3-K-2.5-LE3
	5 m	★ 541341	NEBU-M8W3-K-5-LE3
9 Clip	Technical data → 949		
	125 ... 220	534254	SMBK-8

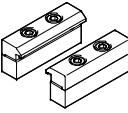
	For size	Part No.	Type
10 Slot nut	Technical data online: → nst		
	125, 160 ¹⁾	150914	NST-5-M5
	160 ²⁾ , 220	150915	NST-8-M6
11 Profile mounting	Dimensions online: → egc-hd-bs		
	125	★ 558043	MUE-70/80
	160	★ 558043	MUE-70/80
	220	558044	MUE-120/185

- 1) For mounting slot at side.
- 2) For mounting slot underneath.

Accessories – Ordering data

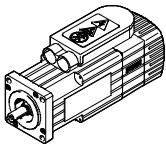
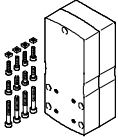
Motor	Parallel kit	
		
	Part No.	Type
12/13 Permissible axis/motor combination with parallel kit Technical data online: → eamm-u		
EGC-HD-125		
With servo motor		
EMMS-AS-40-...	1217708	EAMM-U-50-S38-40A-78
EMMS-AS-55-...	1218538	EAMM-U-60-S38-55A-91
With stepper motor		
EMMS-ST-42-...	1217945	EAMM-U-50-S38-42A-78
EMMS-ST-57-...	1218568	EAMM-U-60-S38-57A-91
EGC-HD-160		
With servo motor		
EMMS-AS-55-...	1219370	EAMM-U-60-S48-55A-91 ¹⁾
EMMS-AS-70-...	1217689	EAMM-U-86-S48-70A-102 ¹⁾
With stepper motor		
EMMS-ST-57-...	1219379	EAMM-U-60-S48-57A-91 ¹⁾
EMMS-ST-87-...	1217604	EAMM-U-86-S48-87A-177 ¹⁾
EGC-HD-220		
With servo motor		
EMMS-AS-70-...	1217543	EAMM-U-86-S62-70A-177 ¹⁾
EMMS-AS-100-...	1217381	EAMM-U-110-S62-100A-207 ¹⁾
EMMS-AS-140-...	1219440	EAMM-U-145-S62-140A-288 ¹⁾
With stepper motor		
EMMS-ST-87-...	1217373	EAMM-U-86-S62-87A-177 ¹⁾

Note

1) These parallel kits include a counter bearing EAMG for supporting the axis shaft.
More information → [eamm-u](#)

Note

The clamping component EADT is required to adjust the toothed belt pretension with EAMM-U-110 and EAMM-U-145.

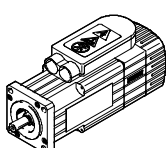
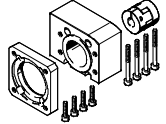
Motor	Axial kit	
		
	Part No.	Type
13/14 Permissible axis/motor combination with axial kit – Technical data online: → eamm-a		
EGC-HD-125		
With servo motor		
EMMS-AS-40-...	558162	EAMM-A-S38-40A
EMMS-AS-55-...	558163	EAMM-A-S38-55A
With stepper motor		
EMMS-ST-42-...	560685	EAMM-A-S38-42A
EMMS-ST-57-...	560686	EAMM-A-S38-57A
EGC-HD-160		
With servo motor		
EMMS-AS-55-...	558164	EAMM-A-S48-55A
EMMS-AS-70-...	558165	EAMM-A-S48-70A
With stepper motor		
EMMS-ST-57-...	560687	EAMM-A-S48-57A
EMMS-ST-87-...	560688	EAMM-A-S48-87A
EGC-HD-220		
With servo motor		
EMMS-AS-70-...	558166	EAMM-A-S62-70A
EMMS-AS-100-...	558167	EAMM-A-S62-100A
EMMS-AS-140-...	558168	EAMM-A-S62-140A
With stepper motor		
EMMS-ST-87-...	560689	EAMM-A-S62-87A

The motor and/or axis shaft can optionally be supported with a counter bearing EAMG.
More information → [eamm-u](#)

Spindle axes EGC-HD-BS, with heavy-duty guide

Dimensions

3

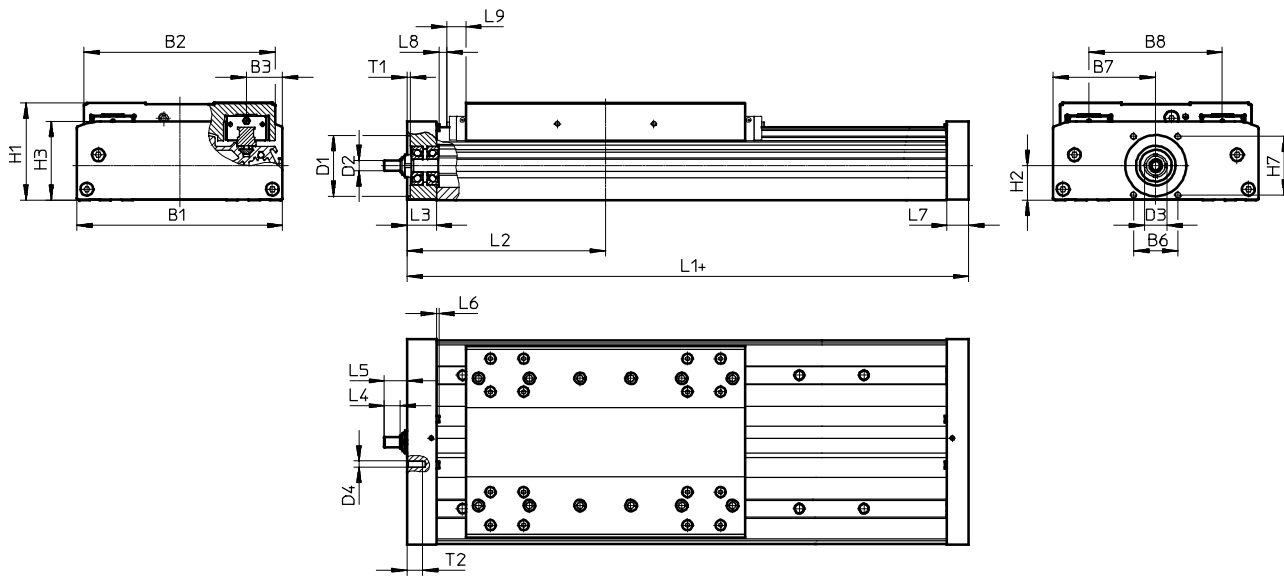

+ = plus stroke length + 2x stroke reserve

Size	B1	B2	B3	B6	B7	B8	D1 ∅ H7	D2 ∅ h6
125	124	120	21	29	62	80	38	6
160	162	150.7	27.5	35	81	105	48	8
220	224	204.2	40	64	112	140	62	12

Size	D3	D4	H1	H2	H3	H7	L3	L4
125	15	M5	64	22.5	50.5	36	21	8
160	18	M5	76.5	27	62	46	23	12.5
220	28	M6	111.5	42.5	89.5	54	33	17.5

Size	L5	L6	L7	L8	L9	T1	T2
125	14	1.8	16	2	–	2.5	12
160	18	2	17	0.55	14.9	2.5	12
220	25.5	2	30	2	18	3	15

Size	Stroke	L1	L2 min.
125	≤900	268	136.5
160	<1,377	296	151.3
	≥1,377	336	171
220	<1,604	409	206
	≥1,604	469	236

Dimensions

GK – Standard slide

Size 125

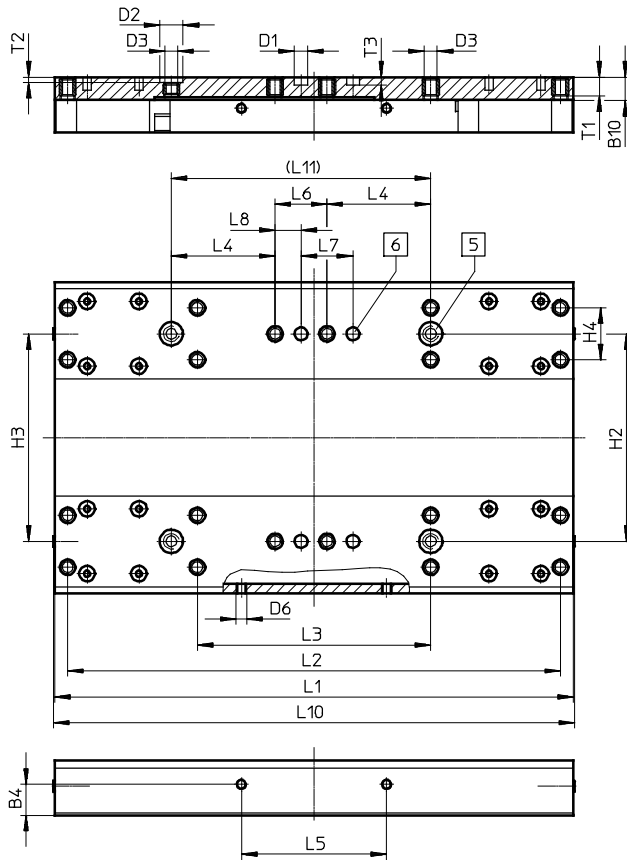

- 5 Hole for centring sleeve ZBH
- 6 Hole for centring pin ZBS

Size	B4	B10	D1 ∅	D2 ∅	D3	D6	H2	H3	H4	L1	L2	L3
	±0.1		H7	H7			±0.03	±0.05	±0.1	±0.1	±0.2	±0.1
125	12	9	5	9	M5	M4	80	80	20	200	190	90

Size	L4	L5	L6	L7	L8	L10	L11	T1	T2	T3
	±0.1	±0.2	±0.1	±0.03	±0.1		±0.03		+0.1	+0.1
125	40	56	20	20	10	202	100	7.8	2.1	3.1

Spindle axes EGC-HD-BS, with heavy-duty guide

Dimensions

GK – Standard slide

Size 160

3

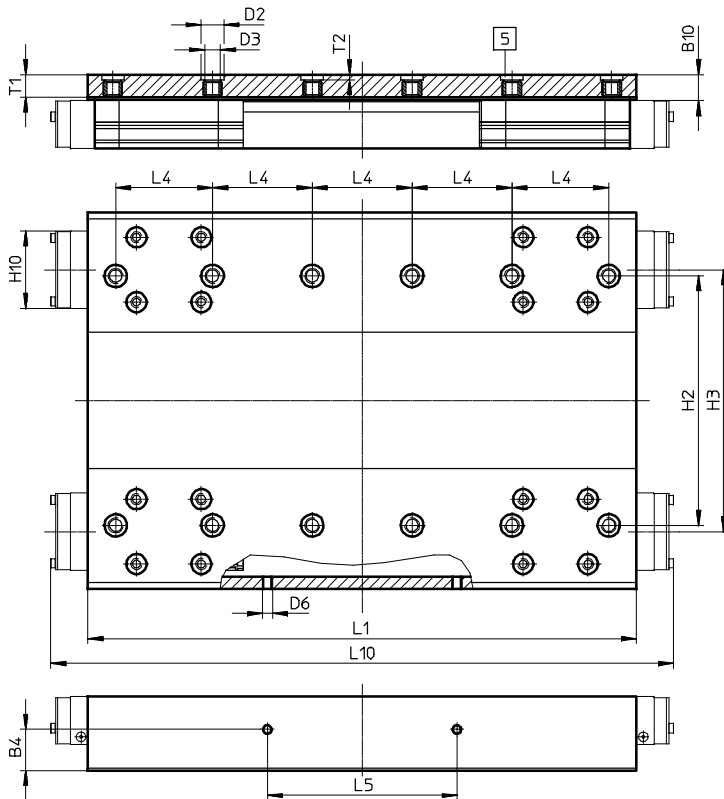

5 Hole for centring sleeve ZBH

Size	B4	B10*	D2 ∅ H7	D3	D6	H2 ±0.03	H3 ±0.05
160	16.5	10.5	9	M6	M4	100	105

Size	H10*	L1 ±0.1	L4 ±0.03	L5 ±0.1	L10*	T1	T2 +0.1
160	31	220	40	76	250	9	2.1

* Protected version

Dimensions

GK – Standard slide

Size 220

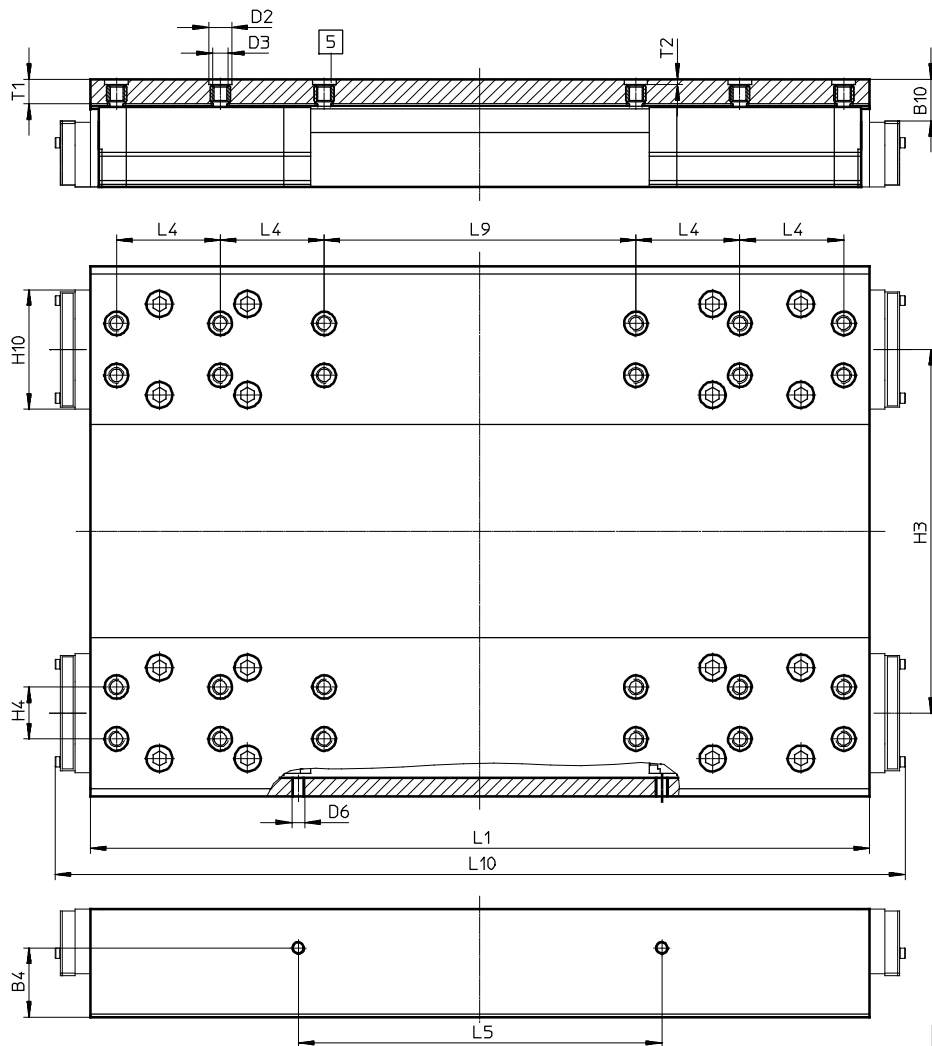

5 Hole for centring sleeve ZBH

Size	B4	B10*	D2 ∅ H7	D3	D6	H3	H4	H10*
220	±0.1 26.6	16	9	M6	M5	±0.05 140	±0.03 20	45.95

Size	L1	L4	L5	L9	L10*	T1	T2
220	±0.1 302	±0.03 40	±0.1 140	±0.03 120	328	9.5	+0.1 2.1

* Protected version

Toothed belt axes EGC-TB-KF, with recirculating ball bearing guide

3



- High speeds and feed forces
- Recirculating ball bearing guide and rigid profile
- Large loads and torques
- Free choice of motor assembly
- Spare parts service

→ www.festo.com/catalogue/egc-tb

Product range overview

Type/version	Size	Stroke [mm]	Feed force [N]	Product options GK	→ Page/online
EGC-TB					
KF – Recirculating ball bearing guide	50, 70, 80, 120, 185	50 ... 8,500	50 ... 2,500	■	345
EGC-FA					
Passive guide axis	70, 80, 120, 185	50 ... 8,500	–	■	egc-fa

Product options

GK Standard slide	KL Additional slide on left	M2 Displacement encoder (resolution: 10 µm)	1HR Clamping unit, 1-channel, on right
GV Extended slide	KR Additional slide on right	1HL Clamping unit, 1-channel, on left	2H Clamping unit, 2-channel
GP Standard slide, protected	C Lubrication adapter		PN Pneumatically actuated clamping unit
GQ Extended slide, protected	M1 Displacement encoder (resolution: 2.5 µm)		

At a glance

- | | | | |
|--|--|---|---|
| <p>Powerful</p> <ul style="list-style-type: none"> • Generously sized profiles with an optimised cross section afford maximum rigidity and load capacity • Speed, acceleration and torque resistance set a new standard | <p>Economical</p> <ul style="list-style-type: none"> • In addition to the technical data, the toothed belt axis impresses with its excellent price/performance ratio • Due to the EGC's high performance it is often possible to use a smaller size | <p>Versatile</p> <ul style="list-style-type: none"> • Numerous sizes and variants such as protected guides open up a broad range of applications • Space-saving position sensing with proximity sensor in the profile slot is possible | <ul style="list-style-type: none"> • Wide range of options for mounting on drives • Comprehensive range of mounting accessories for multi-axis combinations |
|--|--|---|---|

Flexible motor mounting

The motor position can be freely selected on 4 sides and can be changed at any time.

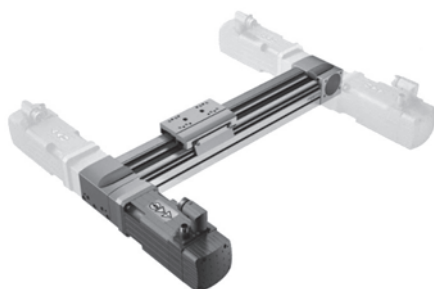

Toothed belt axes EGC-TB-KF, with recirculating ball bearing guide

FESTO

Technical data

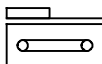

3

Technical data

Dimensions → 351

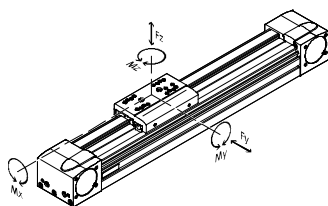

Note

PositioningDrives
sizing software→ www.festo.com

Size		50	70	80	120	185
Working stroke ¹⁾	[mm]	50 ... 1,900	50 ... 5,000	50 ... 8,500	50 ... 8,500	50 ... 8,500
Max. feed force F_x	[N]	50	100	350	800	2,500
Max. no-load torque ²⁾	[Nm]	0.072	0.18	0.4	1.4	4.05
Max. no-load resistance to shifting ¹⁾	[N]	8	14.5	28	70	110
Max. driving torque	[Nm]	0.46	1.24	5	16	93
Max. speed	[m/s]	3	5			
Max. acceleration	[m/s ²]	50				
Repetition accuracy	[mm]	±0.08				±0.1
Max. permissible force F_y	[N]	650	1,850	3,050	6,890	15,200
Max. permissible force F_z	[N]	650	1,850	3,050	6,890	15,200
Max. permissible torque M_x	[Nm]	3.5	16	36	144	529
Max. permissible torque M_y	[Nm]	10	51	97	380	1,157
Max. permissible torque M_z	[Nm]	10	51	97	380	1,157

1) Total stroke = working stroke + 2x stroke reserve.

2) At 0.2 m/s, with variant GK.

Operating conditions

Ambient temperature ³⁾	[°C]	-10 ... +60
Protection class		IP40

3) Note operating range of proximity sensors.

Toothed belt

Size		50	70	80	120	185
Pitch	[mm]	2	3	3	5	8
Expansion ⁴⁾	[%]	0.094	0.08	0.24	0.13	0.29
Width	[mm]	10	15	19.3	30.3	50.5
Effective diameter	[mm]	18.46	24.83	28.65	39.79	73.85
Feed constant	[mm/rev.]	58	78	90	125	232

4) At max. feed force.

Mass moment of inertia

Size		50	70	80	120	185
J_0	[kg mm ²]	16.94	83.34	205.9	1,241	17,976
J_S per metre stroke	[kg mm ² /m]	2.6	10.6	18.8	93	760
J_L per kg effective load	[kg mm ² /kg]	85	154	205	396	1,363.5

The mass moment of inertia J_A of the entire axis is calculated as follows:

$$J_A = J_0 + J_S \times \text{working stroke [m]} + J_L \times m_{\text{effective load [kg]}}$$

Toothed belt axes EGC-TB-KF, with recirculating ball bearing guide

Technical data

Materials	
End cap	Anodised wrought aluminium alloy
Profile	Anodised wrought aluminium alloy
Guide rail	High-alloy steel
Pulleys	Stainless steel
Slide	Anodised wrought aluminium alloy
Toothed belt seals	Polychloroprene with glass cord and nylon coating

3

Order code

		EGC	-		-		-	TB	-	KF	-		-	GK
Type														
EGC	Electromechanical linear axis													
Size														
	Stroke [mm]													
50	50 ... 1,900													
70	50 ... 5,000													
80	50 ... 8,500													
120	50 ... 8,500													
185	50 ... 8,500													
Drive function														
TB	Toothed belt drive													
Guide														
KF	Recirculating ball bearing guide													
Stroke reserve														
...H	0 ... 999 (0 = no stroke reserve)	1												
Slide														
GK	Standard slide													

1 The sum of the stroke length and 2x stroke reserve must not exceed the maximum working stroke.

Ordering – Product options

<input type="checkbox"/> <input type="checkbox"/> <input type="checkbox"/>	Configurable product	This product and all its options can be ordered using the configurator.	The configurator can be found under Products on the DVD or → www.festo.com/catalogue/...	Enter the type code in the search field.
--	-----------------------------	--	--	--

Accessories

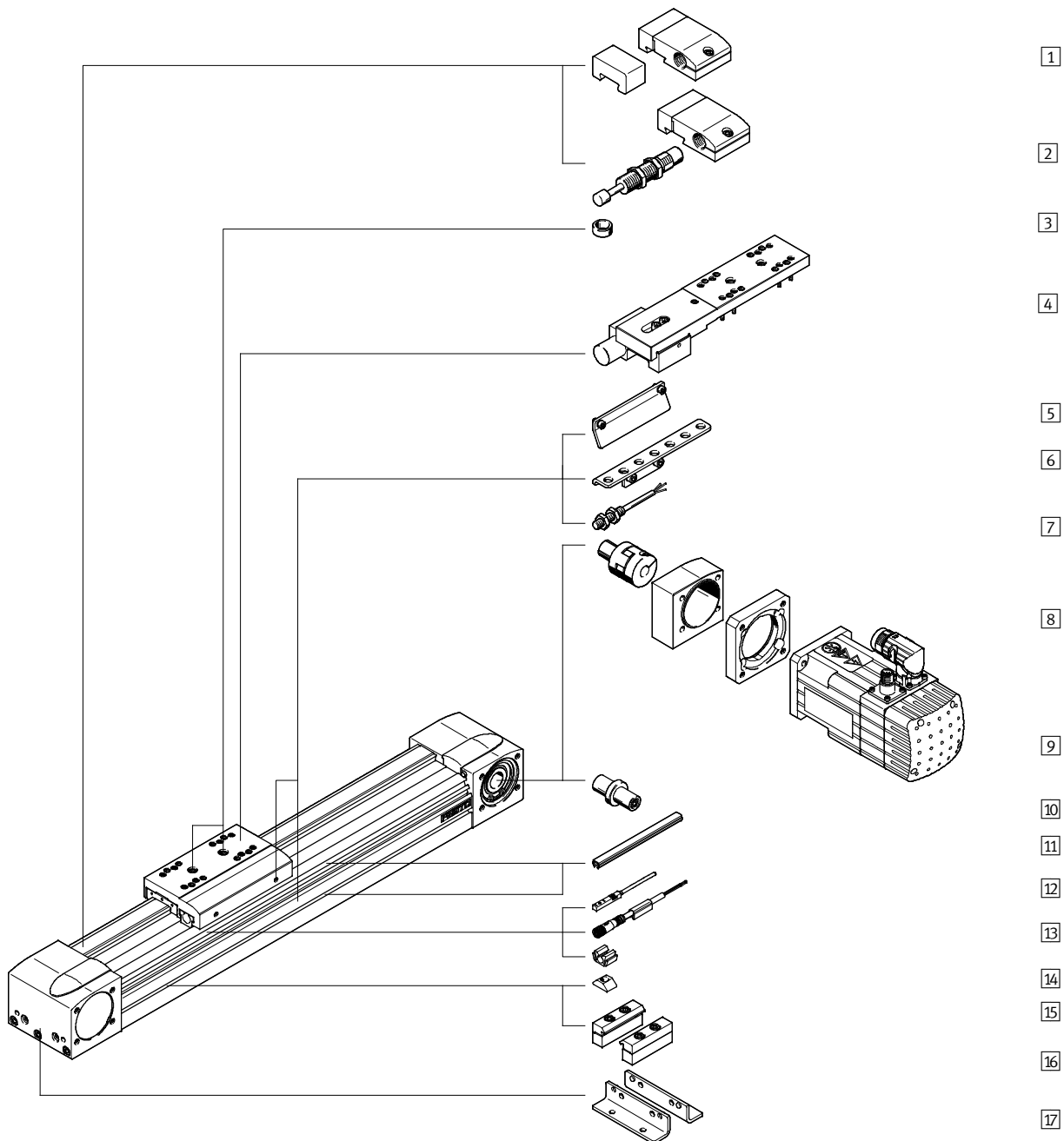



		→ Page/online
1	Emergency buffer NPE/shock absorber retainer KYE	348
2	Shock absorber YSRW/shock absorber retainer KYE	348
3	Centring pin ZBS/centring sleeve ZBH	348
4	Clamping unit 1H...-PN, 2H-PN	egc-tb
5	Switch lug SF-EGC	348
6	Sensor bracket HWS-EGC	348
7	Inductive proximity sensor SIEN	348
8	Axial kit EAMM-A	348
9	Motor EMMS	348

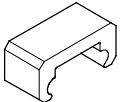
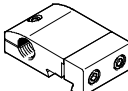
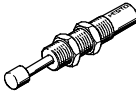

		→ Page/online
10	Drive shaft EAMB	349
11	Slot cover ABP/ABP-S	349
12	Inductive proximity sensor SIES	349
13	Connecting cable NEBU	350
14	Clip SMBK	350
15	Slot nut NST	350
16	Profile mounting MUE	350
17	Foot mounting HPE	350

Toothed belt axes EGC-TB-KF, with recirculating ball bearing guide

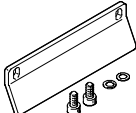
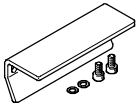
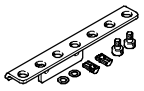
Accessories – Ordering data

	For size	Part No.	Type
1 Emergency buffer			
	50	564897	NPE-50
	70	562581	NPE-70
	80	562582	NPE-80
	120	562583	NPE-120
	185	562584	NPE-185
1 Shock absorber retainer Dimensions online: → egc-tb			
	50	557583	KYE-50
	70	557584	KYE-70
	80	557585	KYE-80
	120	557586	KYE-120
	185	557587	KYE-185
2 Shock absorber Technical data online: → ysrw			
	50	191192	YSRW-5-8
	70	191194	YSRW-8-14
	80	191196	YSRW-12-20
	120	191197	YSRW-16-26
	185	191198	YSRW-20-34
3 Centring pin¹⁾²⁾ Technical data online: → zbs			
	50, 70	150928	ZBS-5
3 Centring sleeve¹⁾²⁾ Technical data online: → zbh			
	80, 120, 185	150927	ZBH-9
5 Switch lug³⁾ Dimensions online: → egc-tb			
	50	558046	SF-EGC-1-50
	70	558047	SF-EGC-1-70
	80	558048	SF-EGC-1-80
	120	558049	SF-EGC-1-120
	185	558051	SF-EGC-1-185
5 Switch lug⁴⁾ Dimensions online: → egc-tb			
	70	558052	SF-EGC-2-70
	80	558353	SF-EGC-2-80
	120	558054	SF-EGC-2-120
	185	558056	SF-EGC-2-185
6 Sensor bracket⁵⁾ Dimensions online: → egc-tb			
	70	558057	HWS-EGC-M5
	80	558057	HWS-EGC-M5
	120	570365	HWS-EGC-M8-B
	185	560517	HWS-EGC-M8:KURZ

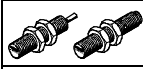
- 1) Packaging unit 10 pieces.
- 2) 2 centring pins/sleeves included in the scope of delivery of the axis.
- 3) For sensing via proximity sensor SIES-8M.
- 4) For sensing via proximity sensor SIEN-M8B or SIES-8M.
- 5) For proximity sensor SIEN-M8B.

	For size	Part No.	Type
7 Inductive proximity sensor, N/O contact, M8 Technical data → 755			
	PNP, cable	★ 150386	SIEN-M8B-PS-K-L
	PNP, plug	★ 150387	SIEN-M8B-PS-S-L
N/C contact, M8 Technical data → 755			
	PNP, cable	150390	SIEN-M8B-PO-K-L
	PNP, plug	150391	SIEN-M8B-PO-S-L

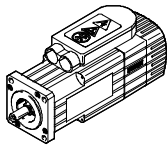
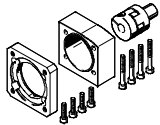
Motor	Axial kit
	
	Part No. Type

8/9 Permissible axis/motor combination with axial kit – Technical data online: → eamm-a		
EGC-50		
With servo motor		
EMMS-AS-55-...	557975	EAMM-A-L27-55A
With stepper motor		
EMMS-ST-57-...	560678	EAMM-A-L27-57A
EGC-70		
With servo motor		
EMMS-AS-70-...	557979	EAMM-A-L38-70A
With stepper motor		
EMMS-ST-57-...	560679	EAMM-A-L38-57A
EMMS-ST-87-...	560680	EAMM-A-L38-87A
EGC-80		
With servo motor		
EMMS-AS-70-...	557982	EAMM-A-L48-70A
EMMS-AS-100-...	557984	EAMM-A-L48-100A
With stepper motor		
EMMS-ST-87-...	560683	EAMM-A-L48-87A
EGC-120		
With servo motor		
EMMS-AS-100-...	557988	EAMM-A-L62-100A
EMMS-AS-140-...	557990	EAMM-A-L62-140A
EGC-185		
With servo motor		
EMMS-AS-140-...	557994	EAMM-A-L95-140A
EMMS-AS-190-...	1378474	EAMM-A-L95-190A

Toothed belt axes EGC-TB-KF, with recirculating ball bearing guide

FESTO



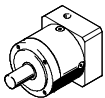
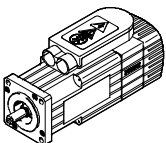
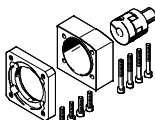

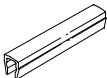
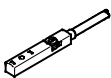
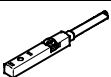
Accessories – Ordering data

Gear unit	Motor	Axial kit	
			
		Part No.	Type
8/9 Permissible axis/motor combination with axial kit –			Technical data online: → eamm-a
EGC-50			
With servo motor			
EMGA-40-P-G3-SAS-40	EMMS-AS-40-...	557974	EAMM-A-L27-40G
EGC-70			
With servo motor			
EMGA-60-P-G3-SAS-55	EMMS-AS-55-...	557978	EAMM-A-L38-60G
EGC-80			
With servo motor			
EMGA-60-P-G3-SAS-70	EMMS-AS-70-...	557983	EAMM-A-L48-60G
EGC-120			
With servo motor			
EMGA-80-P-G3-SAS-100	EMMS-AS-100-...	557989	EAMM-A-L62-80G
EGC-185			
With servo motor			
EMGA-120-P-G3-SAS-140	EMMS-AS-140-...	557995	EAMM-A-L95-120G

	For size	Part No.	Type
10 Drive shaft			
	50	558034	EAMB-16-7-8X15-8X10
	70	558035	EAMB-18-9-8X16-10X12
	80	558036	EAMB-24-6-15X21-16X20
	120	558037	EAMB-34-6-25X26-23X27
	185	558038	EAMB-44-7-35X30-32X32
11 Slot cover¹⁾			
	For mounting slot		
	70, 80	151681	ABP-5
	120, 185	151682	ABP-8
	For sensor slot		
50 ... 185	563360	ABP-5-S1	
12 Proximity sensor for T-slot, inductive, N/O contact			
			Technical data → 759
	PNP, cable	551386	SIES-8M-PS-24V-K-7,5-OE
	PNP, plug	551387	SIES-8M-PS-24V-K-0,3-M8D
	NPN, cable	551396	SIES-8M-NS-24V-K-7,5-OE
	NPN, plug	551397	SIES-8M-NS-24V-K-0,3-M8D
N/C contact			
			Technical data → 759
	PNP, cable	551391	SIES-8M-PO-24V-K-7,5-OE
	PNP, plug	551392	SIES-8M-PO-24V-K-0,3-M8D
	NPN, cable	551401	SIES-8M-NO-24V-K-7,5-OE
	NPN, plug	551402	SIES-8M-NO-24V-K-0,3-M8D

1) Packaging unit 2x 0.5 m.

Accessories – Ordering data

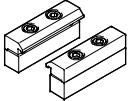
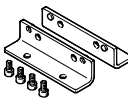
	For size		Part No.	Type	
13 Connecting cable, straight socket					Technical data → 949
	2.5 m	★	541333	NEBU-M8G3-K-2.5-LE3	
	5 m	★	551334	NEBU-M8G3-K-5-LE3	
Angled socket					Technical data → 949
	2.5 m	★	541338	NEBU-M8W3-K-2.5-LE3	
	5 m	★	511341	NEBU-M8W3-K-5-LE3	
14 Clip					
	50 ... 185		534254	SMBK-8	
15 Slot nut					Technical data online: → nst
	50		558045	NST-3-M3	
	70, 80		150914	NST-5-M5	
	120, 185		150915	NST-8-M6	
16 Profile mounting					Dimensions online: → egc-tb
	50		558042	MUE-50	
	70	★	558043	MUE-70/80	
	80	★	558043	MUE-70/80	
	120		558044	MUE-120/185	
	185		558044	MUE-120/185	
17 Foot mounting					Dimensions online: → egc-tb
	50		558320	HPE-50	
	70		558321	HPE-70	
	80		558322	HPE-80	
	120		558323	HPE-120	
	185		558325	HPE-185	

Toothed belt axes EGC-TB-KF, with recirculating ball bearing guide

Dimensions

Download CAD data → www.festo.com

3

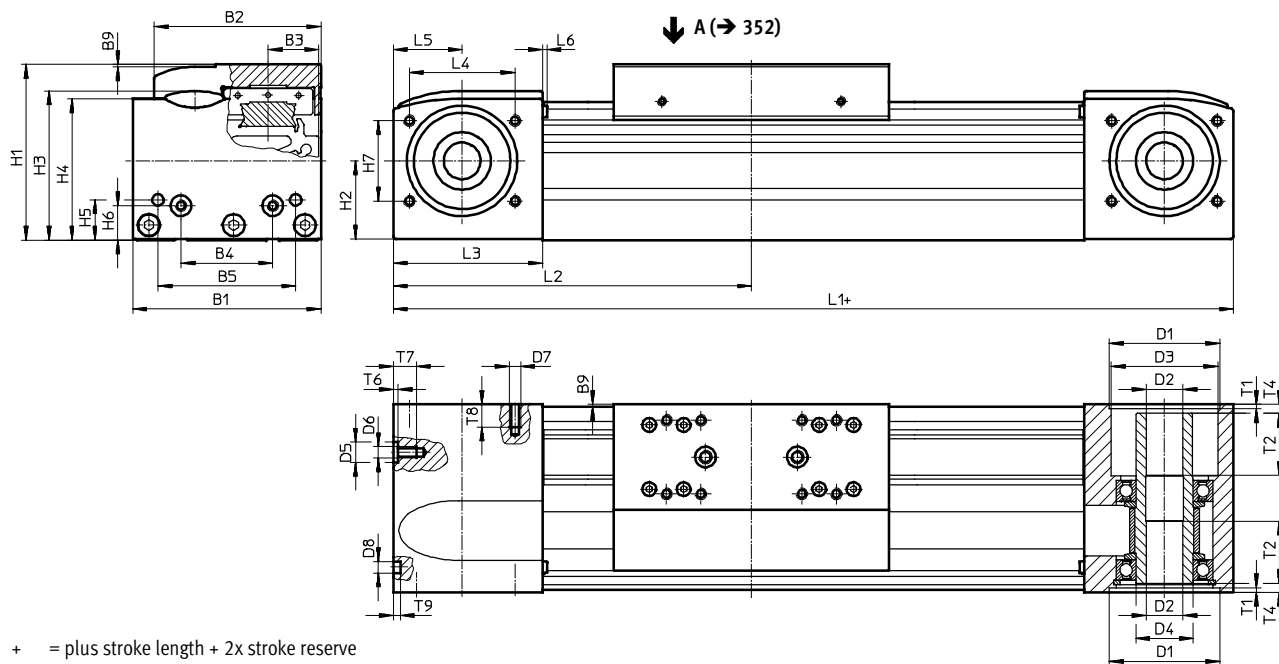

+ = plus stroke length + 2x stroke reserve

Note

To avoid distortion in the slide, the bearing surfaces of the attachments must maintain a minimum flatness of 0.01 mm.

Size	B1	B2	B3	B4	B5	B9	D1	D2	D3	D4	D5	D6
							H7	∅	∅	∅	∅	H7
50	48	39	11.5	20	35	1	27	8	20	15	-	M4
70	69	58.6	16.5	30	45	1	38	10	28	20	-	M5
80	82	72.6	22	40	60	1	48	16	46.5	25	9	M5
120	120	107	33	80	40	1	62	23	59	35	-	M8
185	186	169	53	120	80	1	95	32	90	60	-	M10

Size	D7	D8	H1	H2	H3	H4	H5	H6	H7	L1	L2
		∅									
		H7									
50	M3	5	42.5	16.5	37.6	35.5	10.5	10.5	18	155	77.5
70	M5	5	64	28	53.7	50.8	13	13	29	246	123
80	M5	5	76.5	34.5	65	61.5	17.5	15	35	286	143
120	M6	9	111.5	51.6	95.9	91.1	22	22	54	446	223
185	M8	9	172.5	80.5	152.6	143	25	25	80	612	306

Size	L3	L4	L5	L6	L8	L9	T1	T2	T4	T6	T7	T8	T9
50	40	26	20	1.8	3	-	1.5	-	5.9	-	7	8	3.1
70	57.5	36	27.5	1.8	3	10.5	2.1	18	7.15	-	10	12	3.1
80	65	46	30	2	3	13	2.1	27	4	2.1	10	10	3.1
120	100	64	50	2	3	18	3.1	29.5	4	-	16	14	2.1
185	140	80	70	2	3	21	2.8	34.5	4	-	20	17	2.1

Toothed belt axes EGC-TB-KF, with recirculating ball bearing guide

Dimensions

GK – Standard slide

Size 50

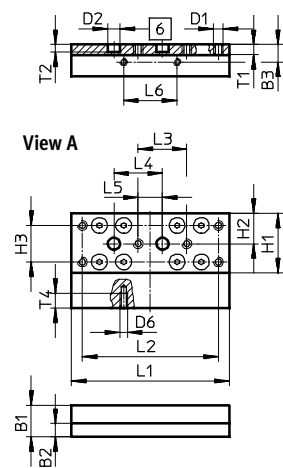

Size 70

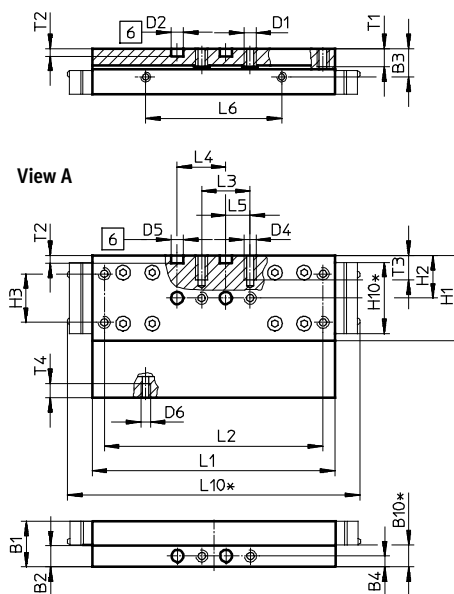

Size 80

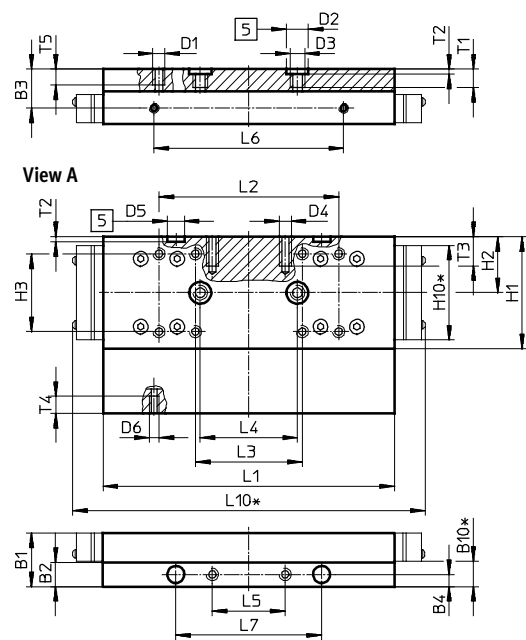

Size 120

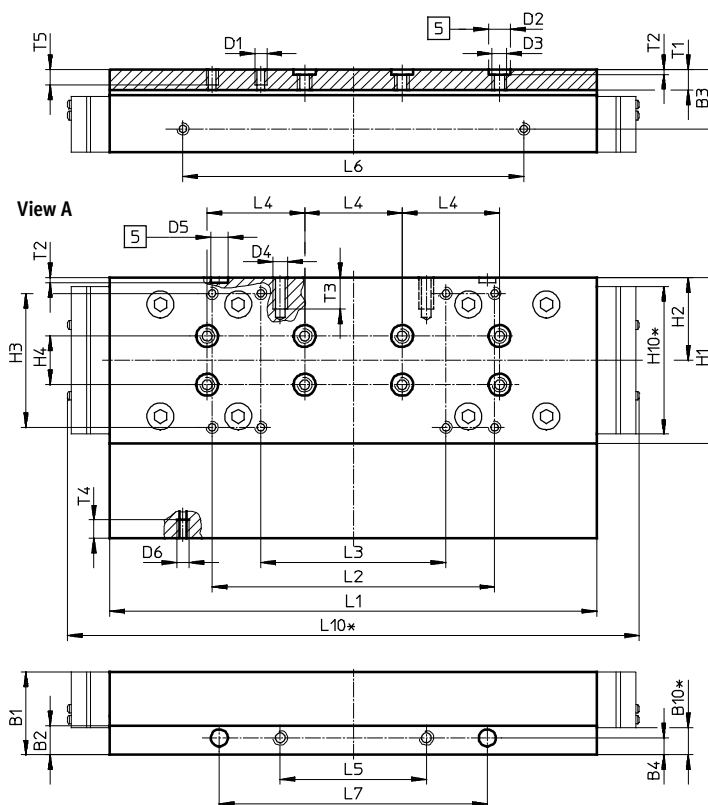

- 5 Hole for centring sleeve
- 6 Hole for centring pin
- * Protected version

Toothed belt axes EGC-TB-KF, with recirculating ball bearing guide

Dimensions

GK – Standard slide

Size 185

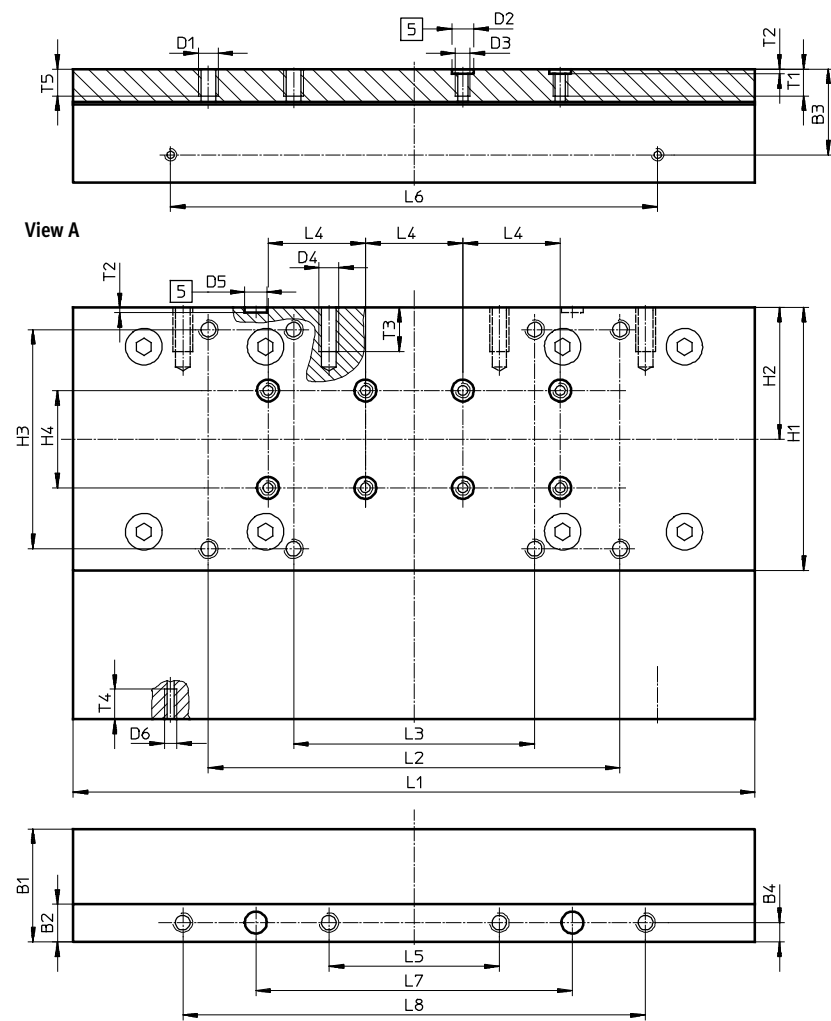

5 Hole for centring sleeve

Size	B1	B2	B3	B4	B10*	D1	D2 ∅ H7	D3	D4	D5 ∅ H7	D6	H1	H2	H3	H4 ±0.03
50	13	5.5	7.2	–	–	M4	5	–	–	–	M3	24.5	12.5	15 ±0.1	–
70	18.7	8.7	11.7	4.5	9	M5	5	–	M5	5	M4	35	17.5	20 ±0.1	–
80	22	10	16	5	10.4	M5	9	M6	M5	7	M4	46	23	32 ±0.2	–
120	34	12	24.5	7	11.2	M5	9	M6	M6	7	M5	68	34	55 ±0.2	20
185	46.5	15.5	35.2	8	–	M8	9	M6	M8	9	M5	108	54	90 ±0.2	40

Size	H10*	L1 ±0.1	L2	L3	L4 ±0.03	L5	L6 ±0.1	L7 ±0.05	L8 ±0.2	L10*	T1	T2 ±0.01	T3	T4	T5
50	–	65	56 ±0.1	20 ±0.1	20	10 ±0.1	22	–	–	–	4.2	3.1	–	6	–
70	29.4	100	90 ±0.1	20 ±0.1	20	10 ±0.1	56	–	–	121	7.5	3.1	10	6	–
80	39	120	74 ±0.2	44 ±0.2	40	30 ±0.1	78	60	–	145	8.6	2.1	12	7	7.5
120	60.6	203.3	116 ±0.2	76 ±0.2	40	60 ±0.1	140	110	–	235	8.6	2.1	13	7.5	7.5
185	–	282.8	169 ±0.2	99 ±0.2	40	70 ±0.2	200	130	190	–	11	2.1	18	12.3	12

* Protected version

Toothed belt axes EGC-HD-TB, with heavy-duty guide

3



- High speeds and feed forces
- Recirculating ball bearing guide and rigid profile
- Maximum loads and torques
- Ideal as a basic axis for linear gantries and cantilever axes
- Spare parts service

→ www.festo.com/catalogue/egc-hd-tb

Product range overview

Type/version	Size	Stroke [mm]	Feed force [N]	Product options GK
EGC-HD-TB				
HD – Heavy-duty guide	125, 160, 220	50 ... 5,000	450 ... 1,800	■

Product options

- | | | | |
|----|---------------------------|----|---------------------------|
| GK | Standard slide | KL | Additional slide on left |
| GP | Standard slide, protected | KR | Additional slide on right |

At a glance

Powerful

- New heavy-duty design for:
 - Maximum loads and torques
 - High feed forces and speeds
 - Long service life

Economical

- In addition to the technical data, the toothed belt axis is a winner with its excellent price/performance ratio
- Space-saving position sensing with proximity sensor in the profile slot is possible

Versatile

- Precision, resilient DUO guide rail
- Ideal as a basic axis for linear gantries and cantilever axes
- Wide range of options for mounting on drives

Flexible motor mounting

The motor position can be freely selected on 4 sides and can be changed at any time.

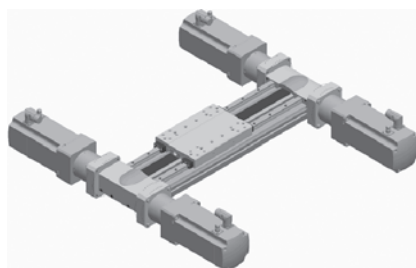

Technical data

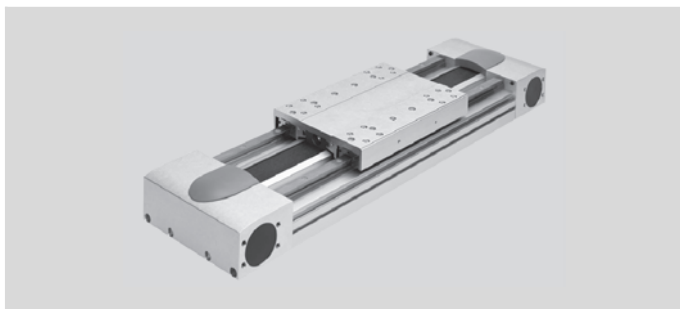
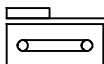

3

Technical data

Dimensions → 360

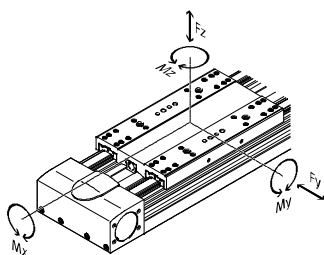

Note

PositioningDrives
sizing software

→ www.festo.com

Size		125	160	220
Working stroke ¹⁾	[mm]	50 ... 3,000	50 ... 5,000	50 ... 4,750
Max. feed force F_x	[N]	450	1,000	1,800
No-load torque ²⁾	[Nm]	0.5	2.1	4.1
Max. no-load resistance to shifting ²⁾	[N]	30.79	105.5	123.8
Max. driving torque	[Nm]	7.2	20	59.58
Max. speed	[m/s]	3	5	
Max. acceleration	[m/s ²]	40	50	
Repetition accuracy	[mm]	±0.08		±0.1
Max. permissible force F_y	[N]	3,650	5,600	13,000
Max. permissible force F_z	[N]	3,650	5,600	13,000
Max. permissible torque M_x	[Nm]	140	300	900
Max. permissible torque M_y	[Nm]	275	500	1,450
Max. permissible torque M_z	[Nm]	275	500	1,450

1) Total stroke = working stroke + 2x stroke reserve.

2) At 0.2 m/s.

Operating conditions

Ambient temperature ³⁾	[°C]	-10 ... +60
Protection class		IP40

3) Note operating range of proximity sensors.

Toothed belt

Size		125	160	220
Pitch	[mm]	3	5	8
Width	[mm]	30.3	40.0	50.5
Expansion ⁴⁾	[%]	0.31	0.23	0.29
Effective diameter	[mm]	32.47	39.79	66.21
Feed constant	[mm/rev.]	102	125	208

4) At max. feed force.

Mass moment of inertia

Size		125	160	220
J_0	[kg cm ²]	4.639	14.49	108.99
J_S per metre stroke	[kg cm ² /m]	0.38	1.267	6.269
J_L per kg effective load	[kg cm ² /kg]	2.635	3.96	10.96

The mass moment of inertia J_A of the entire axis is calculated as follows:

$$J_A = J_0 + J_S \times \text{working stroke [m]} + J_L \times m_{\text{effective load [kg]}}$$

Materials

End cap	Anodised wrought aluminium alloy
Slide	Anodised wrought aluminium alloy
Guide rail	Coated and corrosion-resistant steel
Pulleys	High-alloy stainless steel
Toothed belt	Polychloroprene with glass cord and nylon coating

Toothed belt axes EGC-HD-TB, with heavy-duty guide

Order code

3

		EGC	-	HD	-		-		-	TB	-		-	GK
Type														
EGC	Electromechanical linear axis													
Guide														
HD	Heavy-duty guide													
Size														
	Stroke [mm]													
125	50 ... 3,000													
160	50 ... 5,000													
220	50 ... 4,750													
Drive function														
TB	Toothed belt													
Stroke reserve														
...H	0 ... 999 (0 = no stroke reserve)												1	
Slide														
GK	Standard slide													

1 The sum of the stroke length and 2x stroke reserve must not exceed the maximum working stroke.

Ordering – Product options

<input type="checkbox"/> <input type="checkbox"/> <input type="checkbox"/>	<p>Configurable product</p>	<p>This product and all its options can be ordered using the configurator.</p>	<p>The configurator can be found under Products on the DVD or → www.festo.com/catalogue/...</p>	<p>Enter the type code in the search field.</p>
--	------------------------------------	---	---	---

Accessories

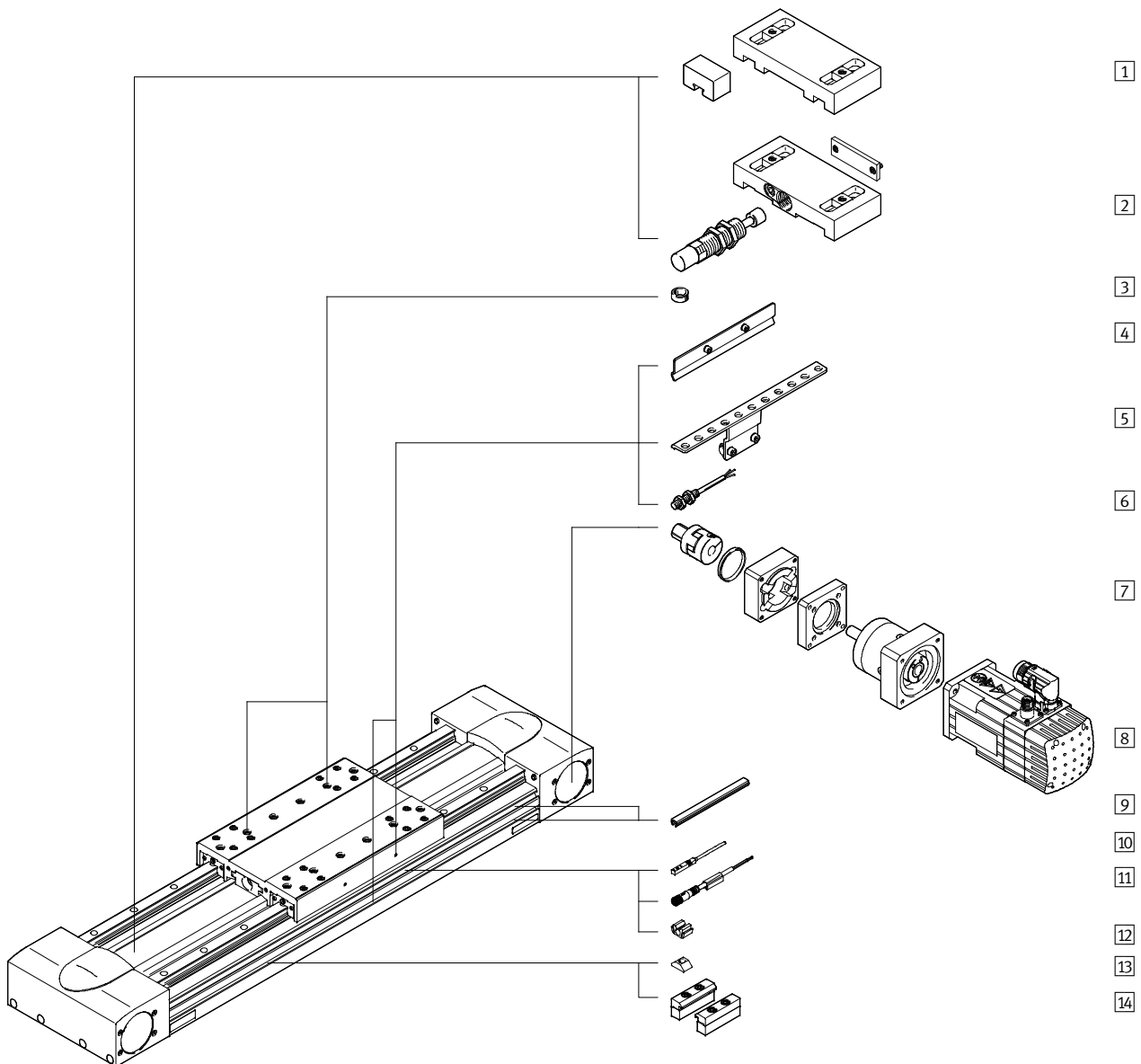





3

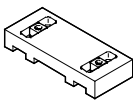

		→ Page/online
1	Emergency buffer NPE/retainer EAYH	358
2	Shock absorber YSRW/shock absorber retainer EAYH	358
3	Centring pin ZBS/centring sleeve ZBH	358
4	Switch lug SF-EGC	358
5	Sensor bracket HWS-EGC	358
6	Inductive proximity sensor SIEN	358
7	Axial kit EAMM-A	358

		→ Page/online
8	Motor EMMS	358
9	Slot cover ABP/ABP-S	359
10	Inductive proximity sensor SIES	359
11	Connecting cable NEBU	359
12	Clip SMBK	359
13	Slot nut NST	359
14	Profile mounting MUE	359

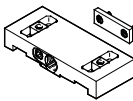
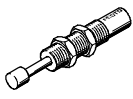
Toothed belt axes EGC-HD-TB, with heavy-duty guide

Accessories – Ordering data

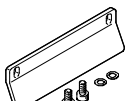
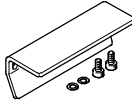
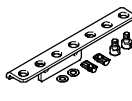

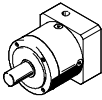
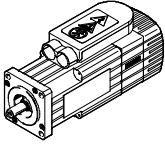
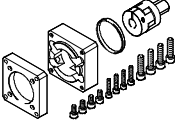

	For size	Part No.	Type
1 Retainer EAYH	Dimensions online: → egc-hd-tb		
	125	1662803	EAYH-L2-125-N
	160	1669259	EAYH-L2-160-N
	220	1669260	EAYH-L2-220-N
1 Emergency buffer	Dimensions online: → egc-hd-tb		
	125	1662475	NPE-125
	160	1672593	NPE-160
	220	1672598	NPE-220
2 Shock absorber retainer EAYH	Dimensions online: → egc-hd-tb		
	125	1653251	EAYH-L2-125
	160	1653250	EAYH-L2-160
	220	1653253	EAYH-L2-220
2 Shock absorber YSRW	Technical data online: → egc-hd-tb		
	125	191196	YSRW-12-20
	160	191197	YSRW-16-26
	220	191198	YSRW-20-34
3 Centring pin¹⁾²⁾	Technical data online: → zbs		
	125	150928	ZBS-5
3 Centring sleeve¹⁾²⁾	Technical data online: → zbh		
	125 ... 220	150927	ZBH-9

	For size	Part No.	Type
4 Switch lug³⁾	Dimensions online: → egc-hd-tb		
	125	570027	SF-EGC-HD-1-125
	160	1645872	SF-EGC-HD-1-160
	220	1645866	SF-EGC-HD-1-220
4 Switch lug⁴⁾	Dimensions online: → egc-hd-tb		
	125	570030	SF-EGC-HD-2-125
	160	1645865	SF-EGC-HD-2-160
	220	1645868	SF-EGC-HD-2-220
5 Sensor bracket⁵⁾	Dimensions online: → egc-hd-tb		
	125	558057	HWS-EGC-M5
	160	558057	HWS-EGC-M5
	220	570365	HWS-EGC-M8-B
6 Inductive proximity sensor,	Technical data → 755		
N/O contact, M8	Technical data → 755		
	PNP, cable	★ 150386	SIEN-M8B-PS-K-L
	PNP, plug	★ 150387	SIEN-M8B-PS-S-L
N/C contact, M8	Technical data → 755		
	PNP, cable	150390	SIEN-M8B-PO-K-L
	PNP, plug	150391	SIEN-M8B-PO-S-L

- 1) Packaging unit 10 pieces.
- 2) 2 centring pins/sleeves included in the scope of delivery of the axis.
- 3) For sensing via proximity sensor SIES-8M.
- 4) For sensing via proximity sensor SIEN-M8B or SIES-8M.
- 5) For proximity sensor SIEN-M8B.

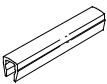
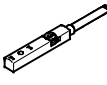
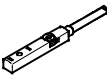
Gear unit	Motor	Axial kit	
			
		Part No.	Type
7/8 Permissible axis/motor combination with axial kit –			
Technical data online: → eamm-a			
EGC-HD-125			
With servo motor			
EMGA-60-P-G...-SAS-70	EMMS-AS-70-...	1190076	EAMM-A-M43-60G
EGC-HD-160			
With servo motor			
EMGA-80-P-G...-SAS-100	EMMS-AS-100-...	1190421	EAMM-A-M48-80G
EGC-HD-220			
With servo motor			
EMGA-120-P-G...-SAS-140	EMMS-AS-140-...	1190774	EAMM-A-M80-120G

Accessories – Ordering data

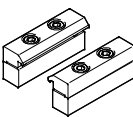
	For size	Part No.	Type	
9 Slot cover¹⁾				
	For mounting slot			
	125, 160 ²⁾	151681	ABP-5	
	160 ³⁾ , 220	151682	ABP-8	
	For sensor slot			
	125 ... 220	563360	ABP-5-S1	
10 Proximity sensor for T-slot, inductive, N/O contact Technical data → 759				
	PNP, cable	551386	SIES-8M-PS-24V-K-7,5-OE	
	PNP, plug	551387	SIES-8M-PS-24V-K-0,3-M8D	
	NPN, cable	551396	SIES-8M-NS-24V-K-7,5-OE	
	NPN, plug	551397	SIES-8M-NS-24V-K-0,3-M8D	
N/C contact Technical data → 759				
	PNP, cable	551391	SIES-8M-PO-24V-K-7,5-OE	
	PNP, plug	551392	SIES-8M-PO-24V-K-0,3-M8D	
	NPN, cable	551401	SIES-8M-NO-24V-K-7,5-OE	
	NPN, plug	551402	SIES-8M-NO-24V-K-0,3-M8D	
11 Connecting cable, straight socket Technical data → 949				
	2.5 m	★	541333	NEBU-M8G3-K-2.5-LE3
	5 m	★	541334	NEBU-M8G3-K-5-LE3
Angled socket Technical data → 949				
	2.5 m	★	541338	NEBU-M8W3-K-2.5-LE3
	5 m	★	541341	NEBU-M8W3-K-5-LE3
12 Clip				
	125 ... 220		534254	SMBK-8
13 Slot nut Technical data online: → nst				
	125, 160 ²⁾		150914	NST-5-M5
	160 ³⁾ , 220		150915	NST-8-M6
14 Profile mounting Dimensions online: → egc-hd-tb				
	125	★	558043	MUE-70/80
	160	★	558043	MUE-70/80
	220		558044	MUE-120/185

1) Packaging unit 2x 0.5 m.

2) For mounting slot at side.

3) For mounting slot underneath.

Toothed belt axes EGC-HD-TB, with heavy-duty guide

Dimensions

3

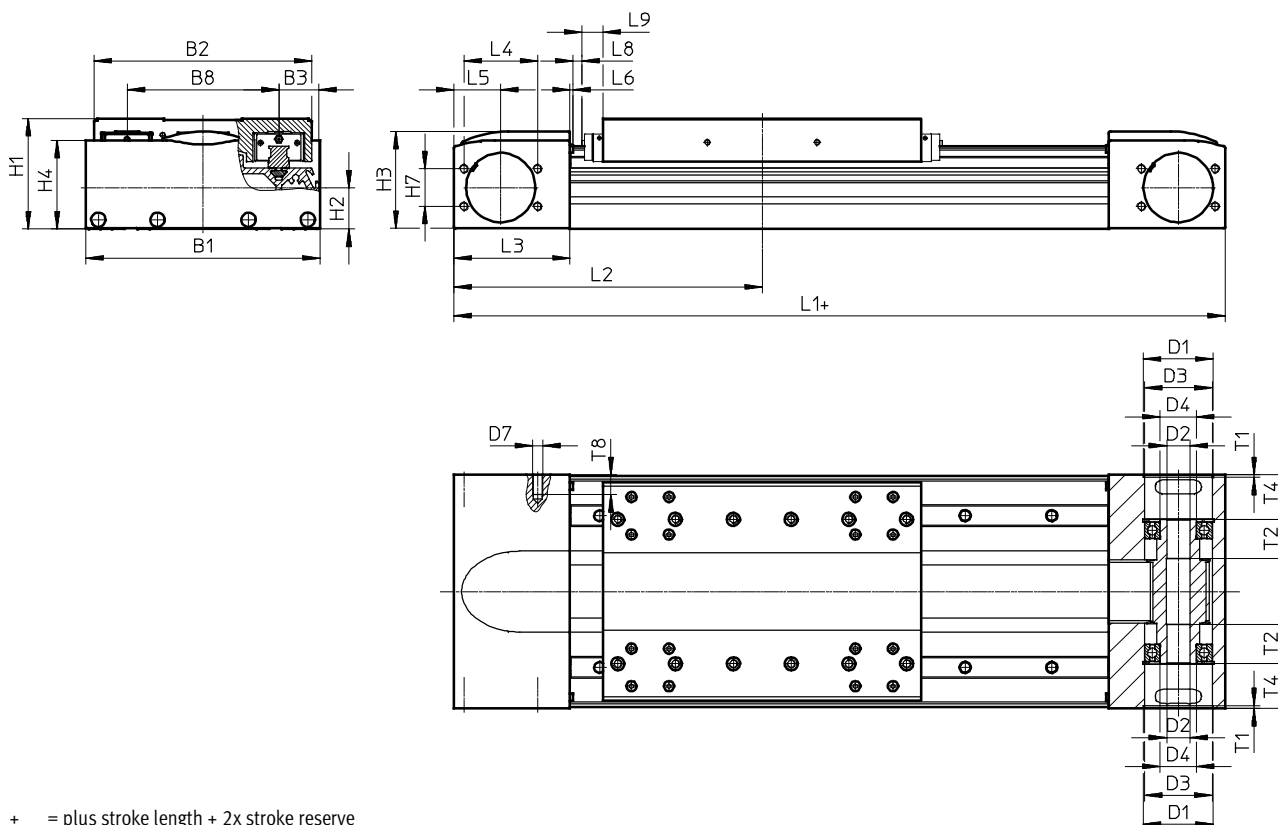

+ = plus stroke length + 2x stroke reserve

Size	B1	B2	B3	B8	D1 ∅ H7	D2 ∅ H7	D3 ∅	D4 ∅	D7
125	124	120	21	80	43	16	42	25	M6
160	162	156	27.5	105	48	16	47	25	M6
220	224	216	40	140	80	23	75	45	M8

Size	H1	H2	H3	H4	H7	L1	L2 min.	L3	L4
125	64	26.1	55.8	50.8	24	346	173	57.5	46
160	76.5	28.7	67.5	61.5	26	417	208.5	80.5	51
220	111.5	45.2	98	91.1	59	576	288	115	76

Size	L5	L6	L8	L9	T1	T2	T4	T8
125	27.5	1.8	2	-	2.1	27	23.65	13
160	32.5	2	0.55	14.9	3.1	27	31.1	14
220	50	2	2	18	3.1	29.5	47.5	16

Dimensions

GK – Standard slide

Size 125

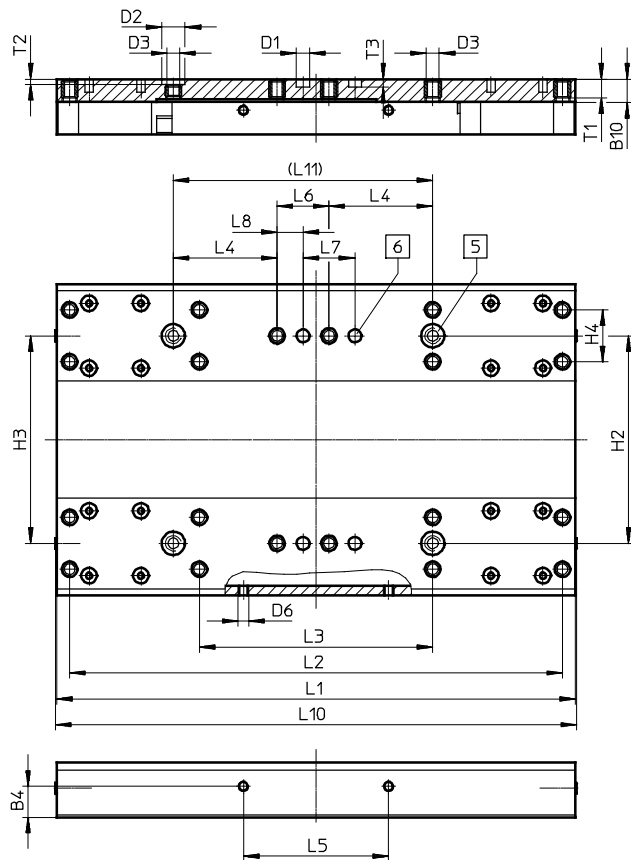

- 5 Hole for centring sleeve ZBH
- 6 Hole for centring pin ZBS

Size	B4	B10	D1 ∅	D2 ∅	D3	D6	H2	H3	H4	L1	L2	L3
	±0.1		H7	H7			±0.03	±0.05	±0.1	±0.1	±0.2	±0.1
125	12	9	5	9	M5	M4	80	80	20	200	190	90

Size	L4	L5	L6	L7	L8	L10	L11	T1	T2	T3
	±0.1	±0.2	±0.1	±0.03	±0.1		±0.03		+0.1	+0.1
125	40	56	20	20	10	202	100	7.8	2.1	3.1

Toothed belt axes EGC-HD-TB, with heavy-duty guide

Dimensions

GK – Standard slide

Size 160

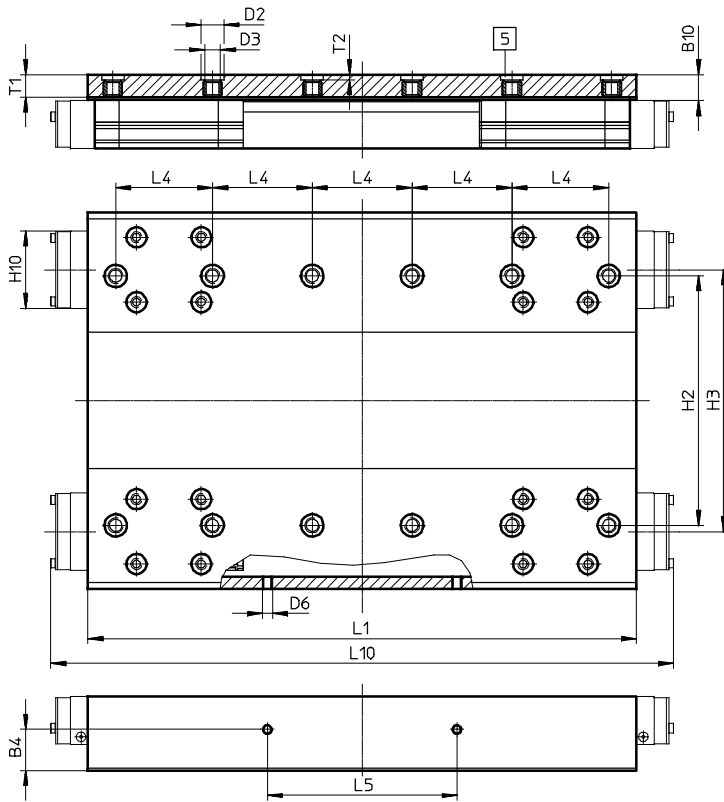

5 Hole for centring sleeve ZBH

Size	B4	B10*	D2 ∅ H7	D3	D6	H2	H3
160	±0.1 16.5	10.5	9	M6	M4	±0.03 100	±0.05 105

Size	H10*	L1	L4	L5	L10*	T1	T2
160	31	±0.1 220	±0.03 40	±0.1 76	250	9	+0.1 2.1

* Protected version

Toothed belt axes EGC-HD-TB, with heavy-duty guide

Dimensions

GK – Standard slide

Size 220

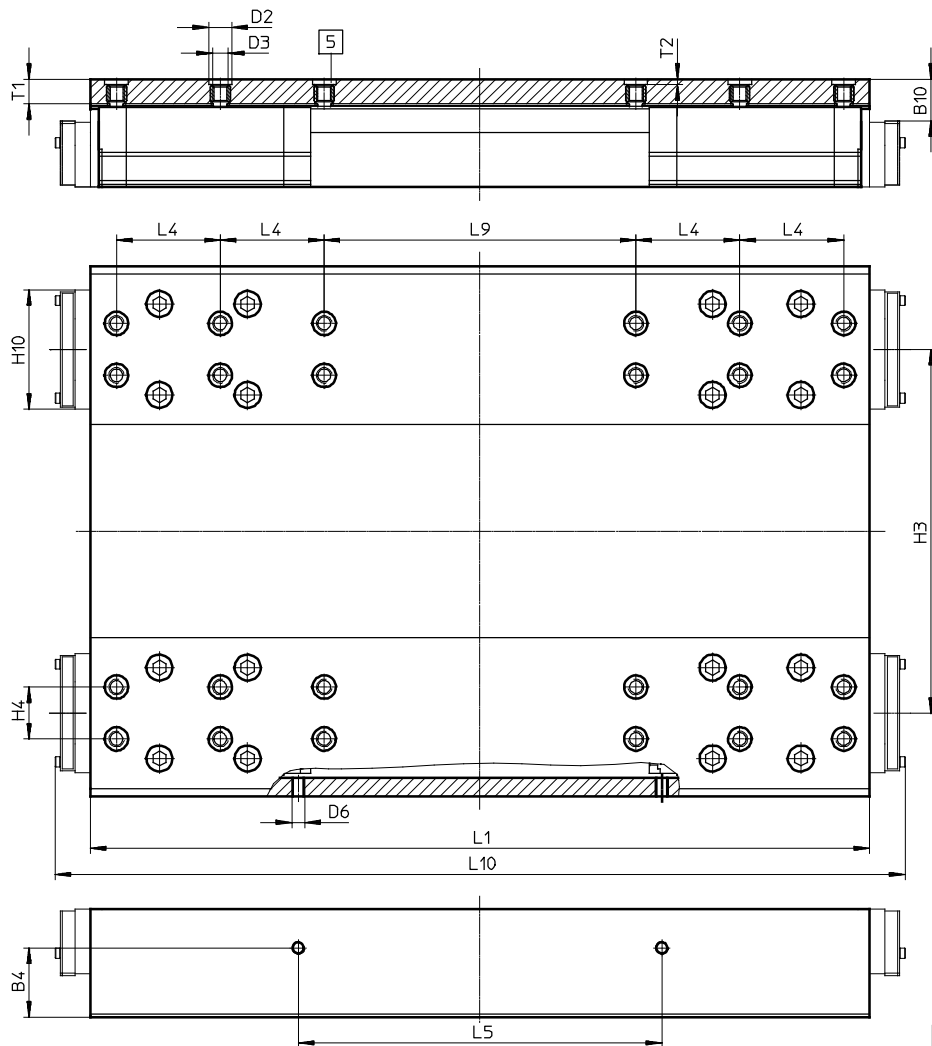

5 Hole for centring sleeve ZBH

Size	B4	B10*	D2 ∅ H7	D3	D6	H3	H4	H10*
220	±0.1 26.6	16	9	M6	M5	±0.05 140	±0.03 20	45.95

Size	L1	L4	L5	L9	L10*	T1	T2
220	±0.1 302	±0.03 40	±0.1 140	±0.03 120	328	9.5	+0.1 2.1

* Protected version

Mini slides EGSL, electric

3



- For vertical applications with variable positioning
- Slides can withstand very high rated loads, ideal for applications such as press-fitting or joining
- Enclosed spindle prevents the ingress of dirt or disruptive small parts in the guide area
- Motor can be turned laterally or axially for attachment
- ★ Quick ordering of basic designs → 366

→ www.festo.com/catalogue/egsl

Product range overview

Type/version	Size	Stroke [mm]	Feed force [N]	Speed [m/s]
EGSL				
Electric	35, 45, 55, 75	50 ... 300	75 ... 450	0.5 ... 1.3

Technical data

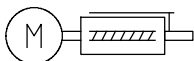

Technical data	Dimensions → 370								
	Size	35		45		55		75	
Spindle pitch [mm]		8	3	10	5	12.7	10	20	
Working stroke [mm]		50	100, 200		100, 200, 250		100, 200, 300		
Guide value for effective load, horizontal [kg]		2	6		10		14		
Guide value for effective load, vertical [kg]		2	6		10		14		
Continuous feed force F_x [N]		50	100		200		300		
Max. feed force F_x [N]		75	150		300		450		
Max. no-load driving torque [Nm]		0.015	0.055	0.050	0.10	0.135	0.265	0.165	
Max. driving torque ¹⁾ [Nm]		0.2	0.45	0.51	0.9	1.25	3.25	3.25	
Max. radial force ²⁾ [N]		20	120		260		300		
Max. speed [m/s]		0.5	0.3	1.0	0.4	1.0	0.65	1.3	
Nominal acceleration [m/s ²]		15							
Max. acceleration ³⁾ [m/s ²]		25							
Repetition accuracy [mm]		±0.015							
Max. reversing backlash ⁴⁾ [µm]		≤50							

1) Friction and torque due to acceleration of the rotating load taken into consideration.
 2) At the drive shaft.
 3) The max. acceleration is dependent on the moving load, the driving torque and the max. feed force.
 4) In new condition.

Note

All values are based on a room temperature of 20 °C.

Technical data

Permissible forces and torques/geometric characteristics

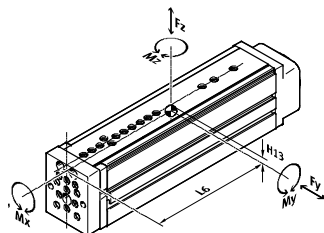

Note

PositioningDrives
sizing software

→ www.festo.com

Size	Stroke [mm]	Fy _{max} [N]	Fz _{max} [N]	Mx _{max} [Nm]	My _{max} , Mz _{max} [Nm]	H13 [mm]	L6 [mm]
35							
	50	512	512	6.2	6.0	4.2	106
45							
	100	631	631	18.6	16.3	6.4	162
	200	291	291	14.3	12.3	6.4	262
55							
	100	1,047	1,047	33.1	31.0	6.4	180
	200	490	490	24.2	22.6	6.4	280
	250	563	563	27.0	33.3	6.4	344
75							
	100	1,539	1,539	67.4	47.1	7.6	187
	200	714	714	48.5	33.8	7.6	287
	300	555	555	46.4	36.5	7.6	389

3

Operating conditions		35	45	55	75
Size					
Ambient temperature	[°C]	0 ... +60			
Protection class		IP40			

Materials	
Yoke plate	Anodised wrought aluminium alloy
Guide rail	Rolled steel
Housing	Anodised wrought aluminium alloy
Spindle	Rolled steel
Spindle nut	Rolled steel
End cap	Painted die-cast aluminium

Order code

EGSL

-

BS

-

-

-

Type	
EGSL	Mini slide

Drive function	
BS	Ball screw spindle

Size		
	Stroke [mm]	Spindle pitch [mm]
35	50	8P
45	100, 200	3P, 10P
55	100, 200, 250	5P, 12.7P
75	100, 200, 300	10P, 20P

Ordering – Product options

Configurable product

This product and all its options can be ordered using the configurator.

The configurator can be found under Products on the DVD or
→ www.festo.com/catalogue/...

Enter the type code in the search field.

Mini slides EGSL, electric

★ Quick ordering

Stroke [mm]	Part No.	Type
EGSL-35		
Spindle pitch 8 mm		
50	562160	EGSL-BS-35-50-8P
EGSL-45		
Spindle pitch 3 mm		
100	562225	EGSL-BS-45-100-3P
200	562226	EGSL-BS-45-200-3P
Spindle pitch 10 mm		
100	559335	EGSL-BS-45-100-10P
200	559336	EGSL-BS-45-200-10P
EGSL-55		
Spindle pitch 5 mm		
100	562227	EGSL-BS-55-100-5P
200	562228	EGSL-BS-55-200-5P
250	562229	EGSL-BS-55-250-5P

Stroke [mm]	Part No.	Type
EGSL-55		
Spindle pitch 12.7 mm		
100	559337	EGSL-BS-55-100-12.7P
200	559338	EGSL-BS-55-200-12.7P
250	559339	EGSL-BS-55-250-12.7P
EGSL-75		
Spindle pitch 10 mm		
100	562230	EGSL-BS-75-100-10P
200	562231	EGSL-BS-75-200-10P
300	562232	EGSL-BS-75-300-10P
Spindle pitch 20 mm		
100	559340	EGSL-BS-75-100-20P
200	559341	EGSL-BS-75-200-20P
300	559342	EGSL-BS-75-300-20P

3

Accessories

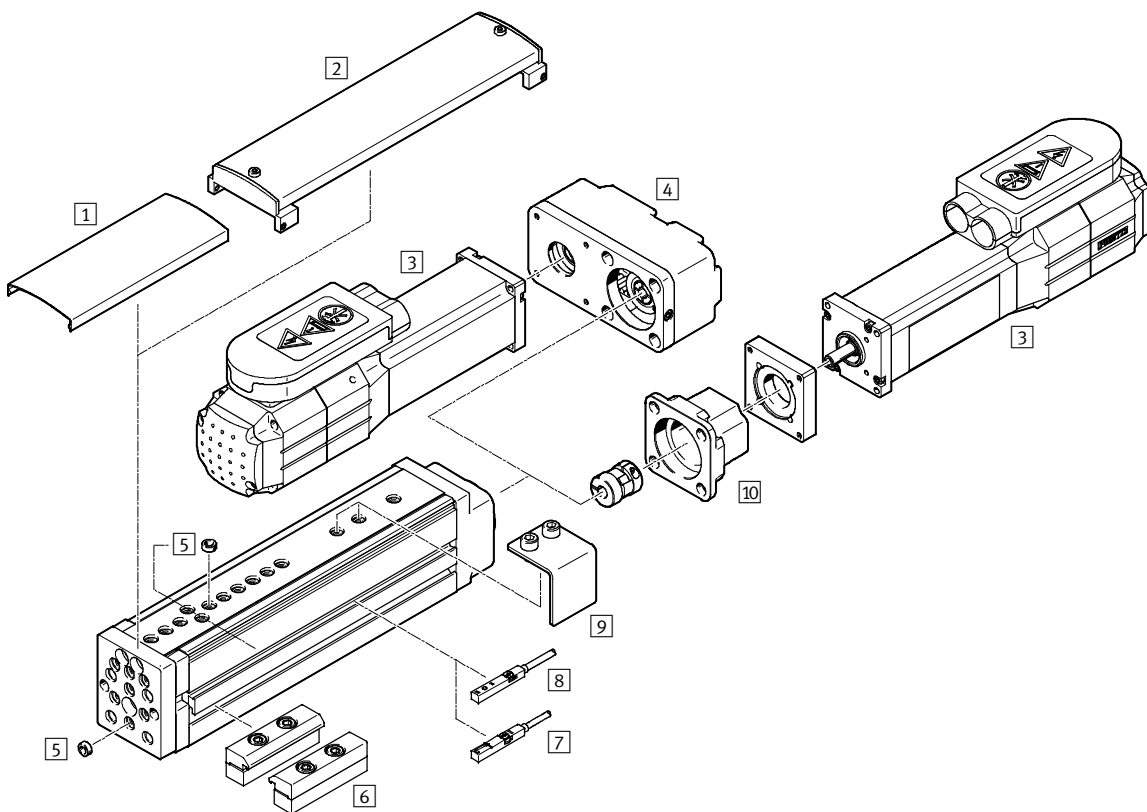

		→ Page/online
1	Cover EASC	367
2	Cover EASC-...-F	367
3	Motor EMMS	367
4	Parallel kit EAMM-U	367
5	Centring sleeve ZBH	368
6	Profile mounting EAHF, MUE	368

		→ Page/online
7	Proximity sensor SIES	369
8	Proximity sensor SMT-8-...-B	369
9	Switch lug EAPM	369
10	Axial kit EAMM-A	367
-	Connecting cable NEBU	369
-	Connector sleeve ZBV	369

Accessories – Ordering data

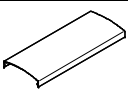
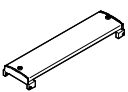
	For size	Length [mm]	Part No.	Type
1 Cover for use without switch lug Dimensions online: → egsl				
	35	50	570819	EASC-G1-35-50
		500 ¹⁾	570874	EASC-G1-35-500
	45	100	570822	EASC-G1-45-100
		200	570823	EASC-G1-45-200
		500 ¹⁾	570875	EASC-G1-45-500
	55	100	570824	EASC-G1-55-100
		200	570825	EASC-G1-55-200
		250	570826	EASC-G1-55-250
		500 ¹⁾	570876	EASC-G1-55-500
	75	100	570827	EASC-G1-75-100
		200	570828	EASC-G1-75-200
		300	570829	EASC-G1-75-300
500 ¹⁾		570877	EASC-G1-75-500	
2 Cover for use with switch lug Dimensions online: → egsl				
	35	50	570830	EASC-G1-35-50-F
		500 ¹⁾	570831	EASC-G1-35-500-F
	45	100	570833	EASC-G1-45-100-F
		200	570834	EASC-G1-45-200-F
	55	100	570835	EASC-G1-55-100-F
		200	570836	EASC-G1-55-200-F
		250	570837	EASC-G1-55-250-F
	75	100	570838	EASC-G1-75-100-F
		200	570839	EASC-G1-75-200-F
		300	570840	EASC-G1-75-300-F

1) The cover can be shortened by the customer as required.

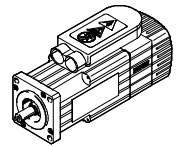
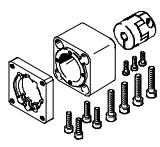
Motor/motor unit	Axial kit
	
	Part No. Type

3/10 Permissible axis/motor combination with axial kit –			
Technical data online: → eamm-a			
EGSL-35			
With servo motor			
EMMS-AS-40-...	★	1199152	EAMM-A-D19-40A
With stepper motor			
EMMS-ST-28-...		1081659	EAMM-A-D19-28A
EMMS-ST-42-...	★	1087642	EAMM-A-D19-42A
EGSL-45			
With servo motor			
EMMS-AS-40-...	★	543147	EAMM-A-D32-40A
EMMS-AS-55-...	★	550979	EAMM-A-D32-55A
With stepper motor			
EMMS-ST-42-...	★	543148	EAMM-A-D32-42A
EMMS-ST-57-...	★	550980	EAMM-A-D32-57A

	Part No.	Type
EGSL-55		
With servo motor		
EMMS-AS-55-...	★	543153 EAMM-A-D40-55A
EMMS-AS-70-...	★	550981 EAMM-A-D40-70A
With stepper motor		
EMMS-ST-57-...	★	543154 EAMM-A-D40-57A
EMMS-ST-87-...	★	550982 EAMM-A-D40-87A
EGSL-75		
With servo motor		
EMMS-AS-70-...	★	543161 EAMM-A-D60-70A
EMMS-AS-100-...	★	550983 EAMM-A-D60-100A
With stepper motor		
EMMS-ST-87-...	★	543162 EAMM-A-D60-87A

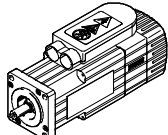
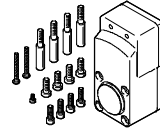
Motor/motor unit	Parallel kit
	
	<ul style="list-style-type: none"> Space-saving gravity die-cast housing
	Part No. Type

3/4 Permissible axis/motor combination with parallel kit –			
Technical data online: → eamm-u			
EGSL-45			
With servo motor			
EMMS-AS-40-...	★	543150	EAMM-U-D32-40A
EGSL-55			
With servo motor			
EMMS-AS-55-...	★	543157	EAMM-U-D40-55A
EGSL-75			
With servo motor			
EMMS-AS-70-...	★	543165	EAMM-U-D60-70A

3

Mini slides EGSL, electric

Accessories – Ordering data

3

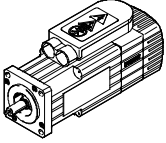
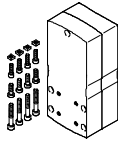
Motor/motor unit	Parallel kit	
		
	<ul style="list-style-type: none"> • Increased housing rigidity • More flexible motor mounting possible • Optionally with protection class IP65 • Use in combination with third-party motors on request 	
	Part No.	Type
3/4 Permissible axis/motor combination with parallel kit –		
Technical data online: → eamm-u		
EGSL-45		
With servo motor		
EMMS-AS-40-...	★	1201591 EAMM-U-50-D32-40A-78
EMMS-AS-55-...	★	1210126 EAMM-U-60-D32-55A-91
With stepper motor		
EMMS-ST-42-...	★	1201607 EAMM-U-50-D32-42A-78
EMMS-ST-57-...	★	1210419 EAMM-U-60-D32-57A-91
With motor unit		
MTR-DCI-32S-...		1570862 EAMM-U-50-D32-32B-78
MTR-DCI-42S-...		1577393 EAMM-U-60-D32-42B/C-91
With gear unit		
EMGA-40-P-...		1577358 EAMM-U-60-D32-40G-91
EGSL-55		
With servo motor		
EMMS-AS-55-...	★	1210438 EAMM-U-60-D40-55A-91
EMMS-AS-70-...	★	1212826 EAMM-U-86-D40-70A-102
With stepper motor		
EMMS-ST-57-...	★	1210442 EAMM-U-60-D40-57A-91
EMMS-ST-87-...	★	1215802 EAMM-U-86-D40-87A-102
With motor unit		
MTR-DCI-42S-...		1570950 EAMM-U-60-D40-42B/C-91
MTR-DCI-52S-...		1537046 EAMM-U-86-D40-52B/C-102
With gear unit		
EMGA-40-P-...		1577165 EAMM-U-60-D40-40G-91
EMGA-60-P-...		1586445 EAMM-U-86-D40-60G-102
EMGC-60-P-...		1586496 EAMM-U-86-D40-60H-102

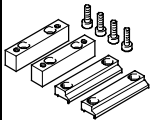

	Part No.	Type
EGSL-75		
With servo motor		
EMMS-AS-70-...	★ 1212477	EAMM-U-86-D60-70A-102
EMMS-AS-100-...	★ 1202436	EAMM-U-110-D60-100A-120
With stepper motor		
EMMS-ST-87-...	★ 1215784	EAMM-U-86-D60-87A-102
With motor unit		
MTR-DCI-52S-...	1537000	EAMM-U-86-D60-52B/C-102
MTR-DCI-62S-...	1536988	EAMM-U-110-D60-62B-120
With gear unit		
EMGA-60-P-...	1586347	EAMM-U-86-D60-60G-102
EMGC-60-P-...	1586276	EAMM-U-86-D60-60H-102
EMGA-60-P-...	1543240	EAMM-U-110-D60-60G-120
EMGC-60-P-...	1543264	EAMM-U-110-D60-60H-120
EMGA-80-P-...	1532949	EAMM-U-110-D60-80G-120

Note
 The clamping component EADT is required to adjust the toothed belt pretension with EAMM-U-110.
 The motor and/or axis shaft can optionally be supported with a counter bearing EAMG.
 More information → [eamm-u](#)

	For size	Part No.	Type
5 Centring sleeve¹⁾			
	35, 45, 55	186717	ZBH-7
	75	150927	ZBH-9
6 Profile mounting			
	35	★ 1170211	EAHF-G1-35-P
	45	★ 1168859	EAHF-G1-45-P
	55	★ 558043	MUE-70/80
	75	★ 558043	MUE-70/80

1) Packaging unit 10 pieces.

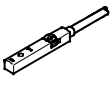
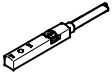
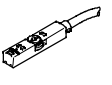
Accessories – Ordering data

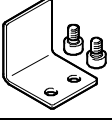
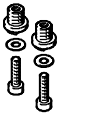
	For size	Part No.	Type	
7	Proximity sensor for T-slot, inductive, N/O contact			Technical data → 759
	PNP, cable	551386	SIES-8M-PS-24V-K-7,5-OE	
	PNP, plug	551387	SIES-8M-PS-24V-K-0,3-M8D	
	NPN, cable	551396	SIES-8M-NS-24V-K-7,5-OE	
	NPN, plug	551397	SIES-8M-NS-24V-K-0,3-M8D	
N/C contact				Technical data → 759
	PNP, cable	551391	SIES-8M-PO-24V-K-7,5-OE	
	PNP, plug	551392	SIES-8M-PO-24V-K-0,3-M8D	
	NPN, cable	551401	SIES-8M-NO-24V-K-7,5-OE	
	NPN, plug	551402	SIES-8M-NO-24V-K-0,3-M8D	
8	Proximity sensor for T-slot, magneto-resistive – N/O contact			Technical data → 737
	PNP, cable	★ 574335	SMT-8M-A-PS-24V-E-2,5-OE	
	PNP, plug	★ 574334	SMT-8M-A-PS-24V-E-0,3-M8D	
Connecting cable, straight socket				Technical data → 949
	2.5 m	★ 541333	NEBU-M8G3-K-2.5-LE3	
	5 m	★ 541334	NEBU-M8G3-K-5-LE3	
Angled socket				Technical data → 949
	2.5 m	★ 541338	NEBU-M8W3-K-2.5-LE3	
	5 m	★ 541341	NEBU-M8W3-K-5-LE3	
9	Switch lug			Dimensions online: → egsl
	35	★ 1235029	EAPM-G1-35-SLS	
	45	★ 1235033	EAPM-G1-45-SLS	
	55	★ 1235035	EAPM-G1-55-SLS	
	75	★ 1235036	EAPM-G1-75-SLS	
Connector sleeve¹⁾				
	45, 55	548803	ZBV-M5-7	
	75	548804	ZBV-M6-9	

1) Packaging unit 3 pieces.

Mini slides EGSL, electric

Dimensions

Size 35

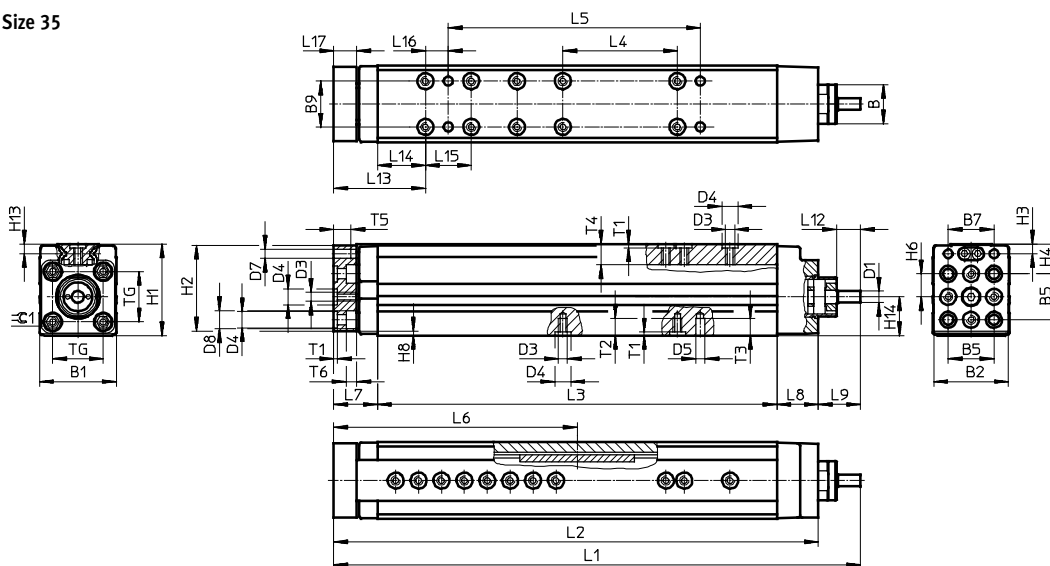

Size 45/55/75

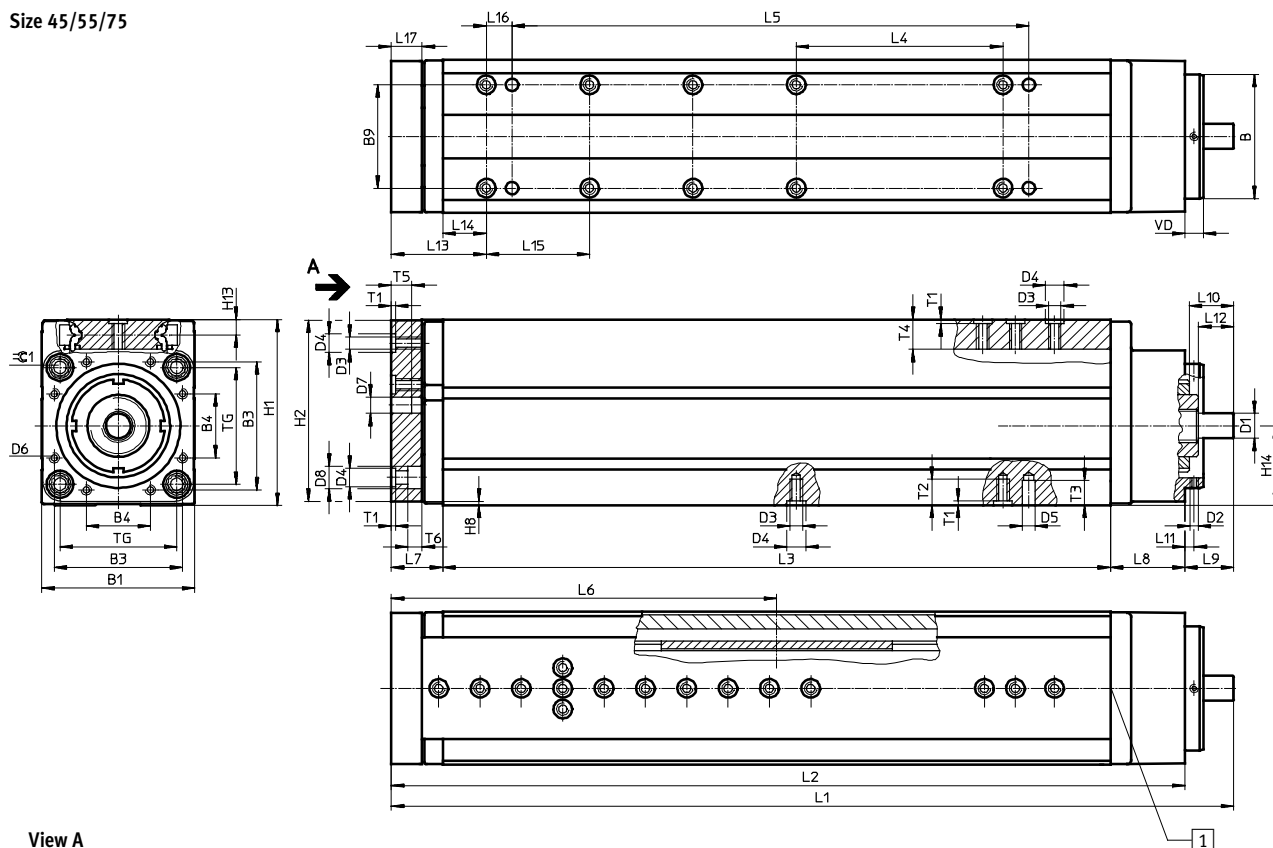

View A
Size 45

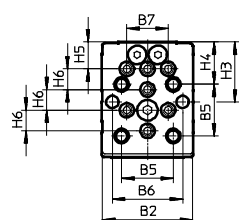

Size 55

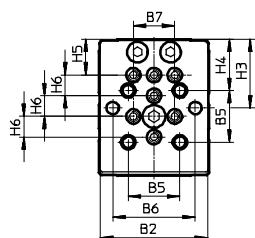

Size 75

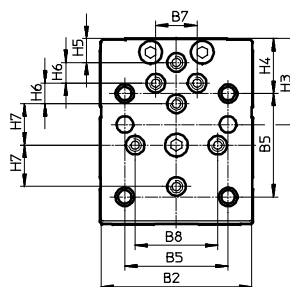

1 Rubber buffer integrated in the slide. Can be removed when homing to fixed stop.

Dimensions

Download CAD data → www.festo.com

Size	B ∅ g7	B1	B2	B3	B4	B5	B6	B7	B8	B9 ±0.5
35	19	33.5	33	–	–	20	–	20	–	20
45	32	44.5	43.5	32	19	25	34	20	–	25
55	40	53	52	42	20	25	40	20	–	25
75	60	74	73	62	31	50	–	20	40	50

Size	D1 ∅	D2	D3	D4 ∅ H7	D5 ∅ H7	D6	D7 ∅	D8 ∅	H1	H2
35	5	–	M4	7	4	–	4	8	40	37.5
45	6	M3	M5	7	6	M3	6	10	56	43.5
55	8	M3	M5	7	6	M4	6	10	66	63.5
75	12	M4	M6	9	6	M5	8	11	90	87.5

Size	H3	H4	H5	H6	H7	H8	H13	H14	L7	
									2) ±1	3) ±1
35	4.2	13	–	10	–	2	4.2	17+0.09/-0.07	21	19
45	29	20.5	13	10	–	2	6.4	23±0.08	22	20
55	33.3	24.8	17.3	10	–	2	6.4	28.7±0.08	27	25
75	41.5	26.5	11.5	10	20	2	7.6	38.5±0.08	27	25

Size	L8	L9 ±1	L10	L11	L12 ±0.2	L13		L14 ¹⁾	L15 ¹⁾	L16 ±0.1
						2)	3)			
35	18	18.5	–	–	10.5	42	40	21	20	10
45	26	16	16.9	3.5	8	43	41	21	25	12.5
55	30	18.5	14.9	3.5	14	48	46	21	25	12.5
75	36	23.6	21.5	4.5	17	48	46	21	50	12.5

Size	L17	T1 ±0.1	T2	T3	T4	T5	T6	TG	VD	≈±1
35	10	1.6	7.6	7.5	9	7.5	4.6	22	–	5
45	10	1.6	8.1	7.5	12.4	7.5	5.7	32.5	7	6
55	15	1.6	8.6	8.5	12.4	10	8.7	38	7	6
75	15	2.1	12.6	12	14.5	10	6.8	56.5	9	8

Size	Stroke [mm]	L1		L2		L3 -0.2	L4 ¹⁾	L5 ¹⁾ ±0.05	L6	
		2) ±1.5	3) ±1.5	2) ±1	3) ±1				2)	3)
		35	50	182	180				163.5	161.5
45	100	248	246	232	230	184	75	125	114	112
	200	348	346	332	330	284	100	175	164	162
55	100	284.5	282.5	266	264	209	100	150	132	130
	200	384.5	382.5	366	364	309	100	175	182	180
	250	463.5	461.5	445	443	388	100	175	221	219
75	100	309.6	307.6	286	284	223	–	150	139	137
	200	409.6	407.6	386	384	323	100	250	189	187
	300	514.6	512.6	491	489	428	150	350	241	239

1) Tolerance for centring hole ±0.02 mm.
Tolerance for thread ±0.1 mm.

2) With rubber buffer.

3) Without rubber buffer: when homing to fixed stop.

Mini slides EGSL, electric

Dimensions

Hole pattern for mounting threads and centring holes

EGSL-35-50

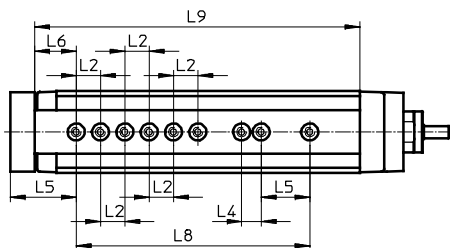

EGSL-45-100

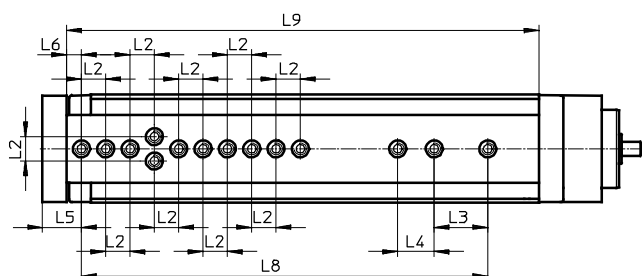

EGSL-45-200

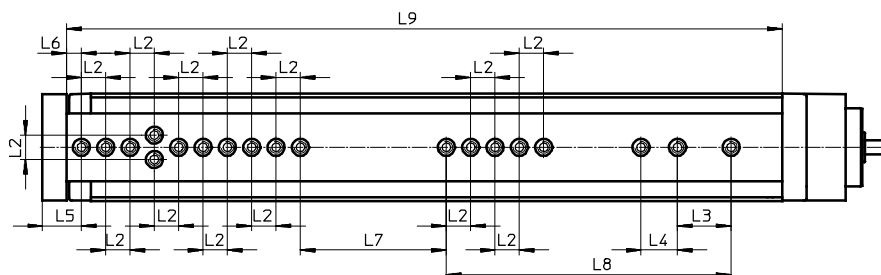

Size	Stroke [mm]	L2 ¹⁾	L3 ¹⁾	L4 ¹⁾	L5	L6	L7 ¹⁾	L8 ¹⁾	L9
35	50	10	20	8	27	17	–	96	133.5
45	100	10	22	15	16	6	–	167	194
	200						60	117	294

1) Tolerance for centring hole ±0.02 mm.
Tolerance for thread ±0.1 mm.

Dimensions

Hole pattern for mounting threads and centring holes

EGSL-55-100

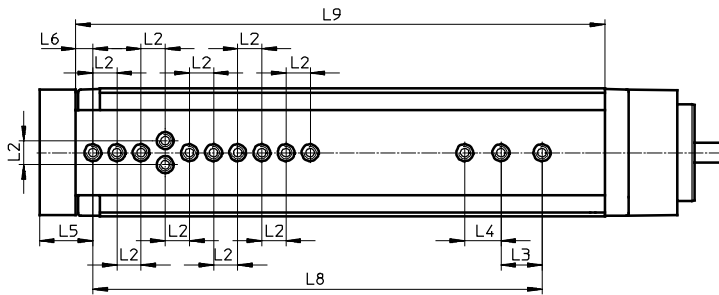

EGSL-55-200

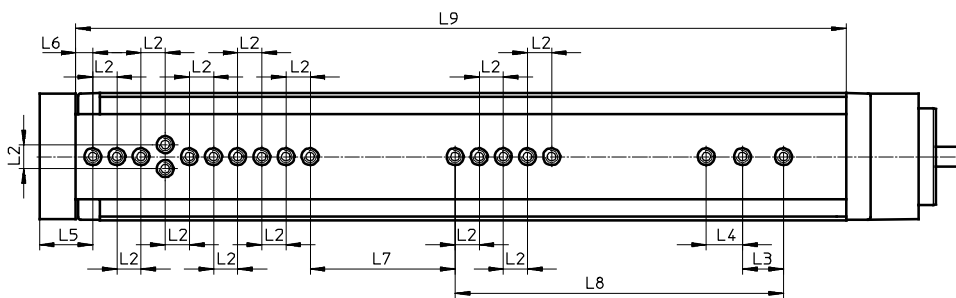

EGSL-55-250

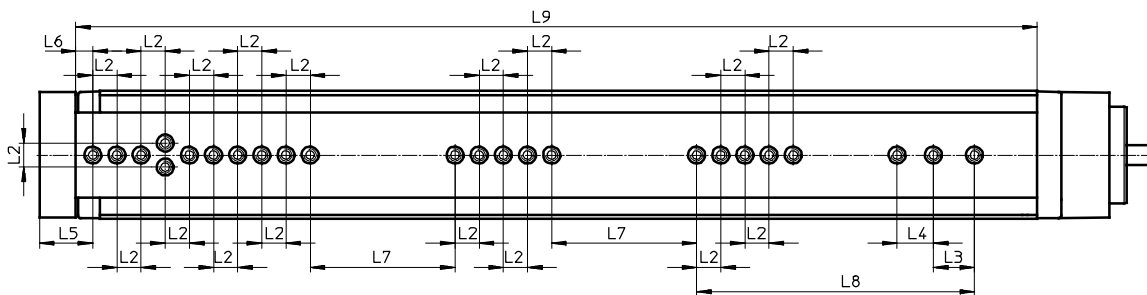

Size	Stroke [mm]	L2 ¹⁾	L3 ¹⁾	L4 ¹⁾	L5	L6	L7 ¹⁾	L8 ¹⁾	L9
55	100	10	17	15	22	7	-	186	219
	200						60	136	319
	250						60	115	398

1) Tolerance for centring hole ±0.02 mm.
Tolerance for thread ±0.1 mm.

Mini slides EGSL, electric

Dimensions

Hole pattern for mounting threads and centring holes

EGSL-75-100

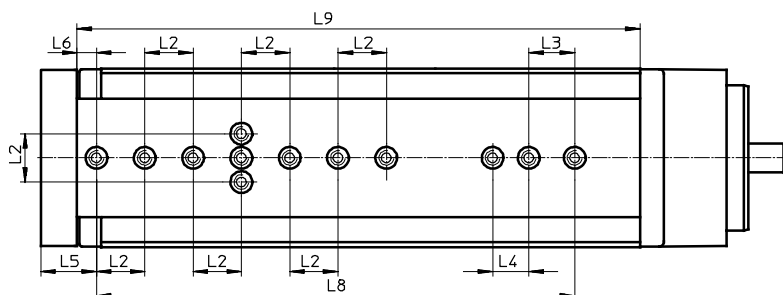

EGSL-75-200

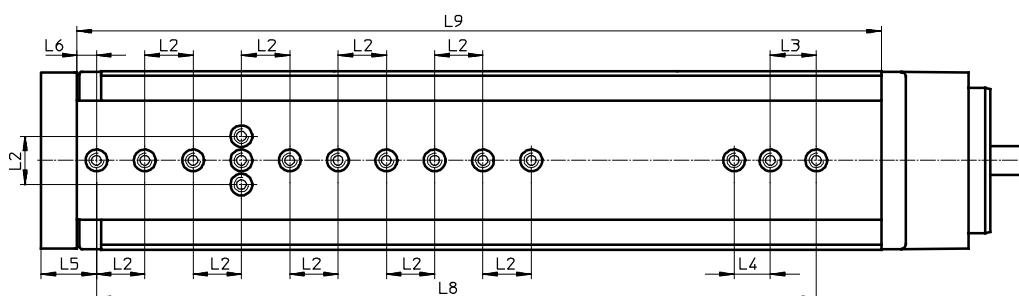

EGSL-75-300

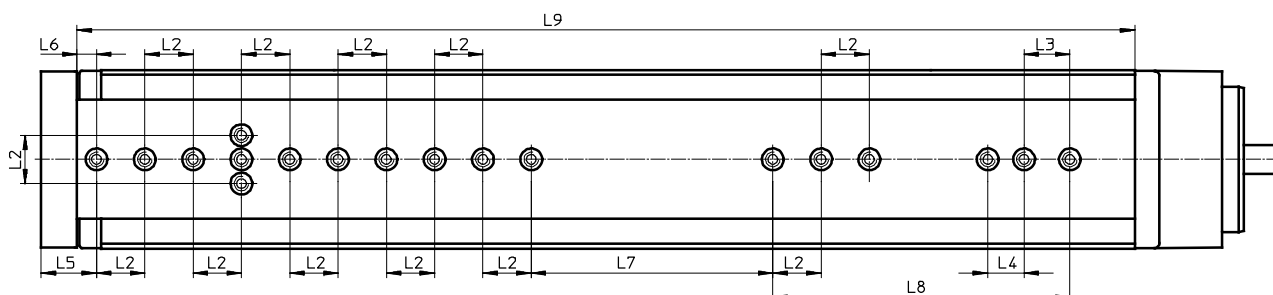

Size	Stroke [mm]	L2 ¹⁾	L3 ¹⁾	L4 ¹⁾	L5	L6	L7 ¹⁾	L8 ¹⁾	L9
75	100	20	19	15	23	8	–	198	233
	200						–	298	333
	300						100	123	438

1) Tolerance for centring hole ±0.02 mm.
Tolerance for thread ±0.1 mm.



- Toothed belt axis with high feed forces
- Free choice of motor assembly
- Spare parts service

3

→ www.festo.com/catalogue/elga

Product range overview

Type/version	Size	Stroke [mm]	Feed force F_x [N]	Product options PO
ELGA-TB				
G – Plain-bearing guide	70, 80, 120	50 ... 8,500	350 ... 1,300	■
RF – Roller bearing guide	70, 80, 120	50 ... 7,400	350 ... 1,300	■

Product options

- With strip cover
- PO Without strip cover

Flexible motor mounting

The motor position can be freely selected on 4 sides and can be changed at any time.

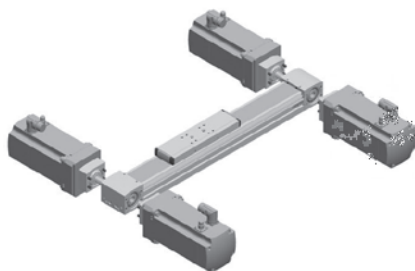

Toothed belt axes ELGA-TB

Technical data

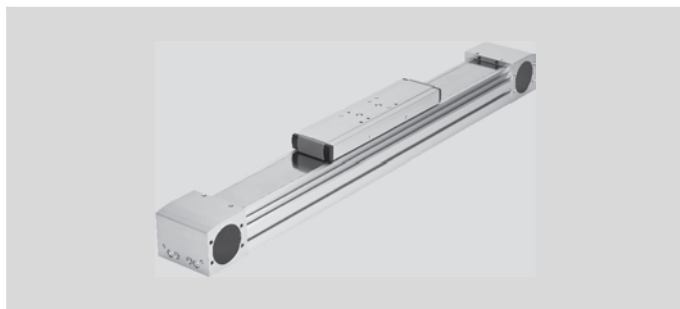
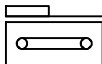

Dimensions → 381

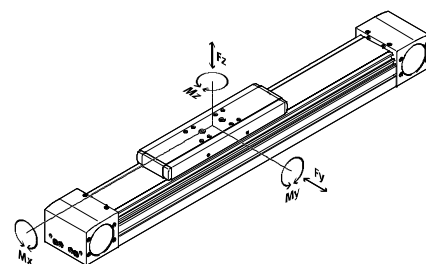

Technical data

Note

PositioningDrives
sizing software

→ www.festo.com

Size		70	80	120
Working stroke	[mm]	50 ... 8,500	50 ... 8,500	50 ... 8,500
Max. feed force F_x	[N]	350	800	1,300
Max. no-load torque ¹⁾	[Nm]	0.5	1	3
Max. driving torque	[Nm]	5	15.9	34.2
Max. no-load resistance to shifting ¹⁾	[N]	35	50	114
Max. speed	[m/s]	5		
Max. acceleration	[m/s ²]	50		
Repetition accuracy	[mm]	±0.08		
Max. permissible force F_y	[N]	80	200	380
Max. permissible force F_z	[N]	400	800	1,600
Max. permissible torque M_x	[Nm]	5	10	20
Max. permissible torque M_y	[Nm]	30	60	120
Max. permissible torque M_z	[Nm]	10	20	40

1) At 0.2 m/s.

Operating conditions

Ambient temperature	[°C]	-10 ... +60
Protection class		IP40

Toothed belt

Size		70	80	120
Pitch	[mm]	3	5	5
Expansion ²⁾	[%]	0.31	0.19	0.23
Effective diameter	[mm]	28.65	39.79	52.52
Feed constant	[mm/ rev.]	90	125	165

2) At max. feed force.

Mass moment of inertia

Size		70	80	120
J_0	[kg mm ²]	175	666	3,201
J_S per metre stroke	[kg mm ² /m]	19	93	215
J_L per kg effective load	[kg mm ² /kg]	205	396	690

The mass moment of inertia J_A of the entire axis is calculated as follows:

$$J_A = J_0 + J_S \times \text{working stroke [m]} + J_L \times m_{\text{effective load [kg]}}$$

Technical data

Materials	
End cap	Anodised wrought aluminium alloy
Profile	Anodised wrought aluminium alloy
Drive cover	Anodised wrought aluminium alloy
Slide guide	POM
Guide rail	Anodised wrought aluminium alloy
Pulleys	High-alloy stainless steel
Slide	Anodised wrought aluminium alloy
Toothed belt clamping component	Stainless steel casting
Toothed belt	Polychloroprene with glass cord and nylon coating

3

Order code

		ELGA	-	TB	-	G	-		-		-		-		
Type															
ELGA	Linear axis														
Drive function															
TB	Toothed belt														
Guide															
G	Plain-bearing guide														
Size															
	Stroke [mm]														
70	1 ... 8,500														
80	1 ... 8,500														
120	1 ... 8,500														
Stroke reserve															
...H	0 ... 999 (0 = no stroke reserve)	1													
Particle protection															
-	Standard														
PO	Without strip cover														

1 The sum of the stroke length and 2x stroke reserve must be at least 50 mm and must not exceed the maximum stroke length.

Ordering – Product options

<input type="checkbox"/> <input type="checkbox"/> <input type="checkbox"/> <input type="checkbox"/>	Configurable product	This product and all its options can be ordered using the configurator.	The configurator can be found under Products on the DVD or → www.festo.com/catalogue/...	Enter the type code in the search field.
---	-----------------------------	--	--	--

Toothed belt axes ELGA-TB

Accessories

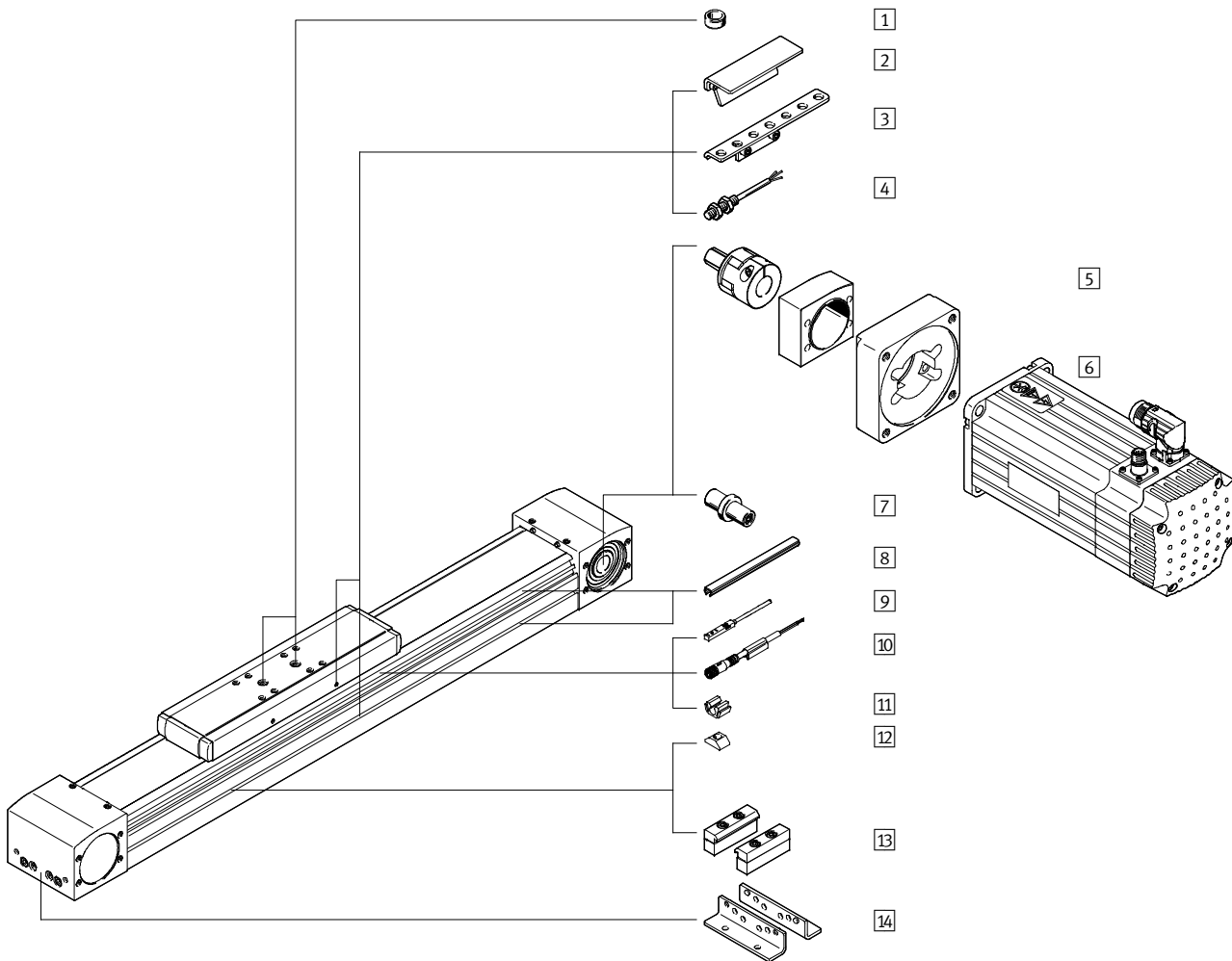

3





		→ Page/online
1	Centring pin ZBS/centring sleeve ZBH	379
2	Switch lug SF-EGC	379
3	Sensor bracket HWS-EGC	379
4	Inductive proximity sensor SIEN	379
5	Axial kit EAMM-A	379
6	Motor EMMS	379
7	Drive shaft EAMB	380

		→ Page/online
8	Slot cover ABP	380
9	Inductive proximity sensor SIES	380
10	Connecting cable NEBU	380
11	Clip SMBK	380
12	Slot nut NST	380
13	Profile mounting MUE	380
14	Foot mounting HPE	380

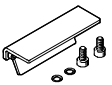
Accessories – Ordering data

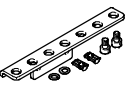
	For size	Part No.	Type
1 Centring pin/sleeve¹⁾²⁾ Technical data online: → zbh			
	70	150928	ZBS-5
	80, 120	150927	ZBH-9
2 Switch lug for sensing with proximity sensor SIES Dimensions online: → elga			
	70	558047	SF-EGC-1-70
	80	558048	SF-EGC-1-80
	120	558049	SF-EGC-1-120
2 Switch lug for sensing with proximity sensor SIEN Dimensions online: → elga			
	70	558052	SF-EGC-2-70
	80	558053	SF-EGC-2-80
	120	558054	SF-EGC-2-120

	For size	Part No.	Type
3 Sensor bracket Dimensions online: → elga			
	70	558057	HWS-EGC-M5
	80	558057	HWS-EGC-M5
	120	570365	HWS-EGC-M8
4 Inductive proximity sensor, N/O contact, M8 Technical data → 755			
	PNP, cable	★ 150386	SIEN-M8B-PS-K-L
	PNP, plug	★ 150387	SIEN-M8B-PS-S-L
N/C contact, M8 Technical data → 755			
	PNP, cable	150390	SIEN-M8B-PO-K-L
	PNP, plug	150391	SIEN-M8B-PO-S-L





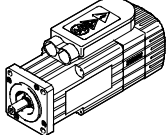
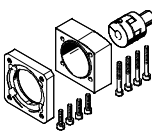

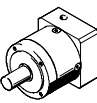
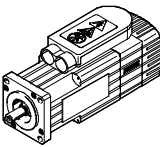
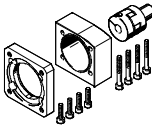
1) Packaging unit 10 pieces.
2) 2 centring sleeves included in the scope of delivery of the axis.

3

Motor	Axial kit
	
	Part No. Type
5/6 Permissible axis/motor combination with axial kit – Technical data online: → eamm-a	
ELGA-TB-...-70	
With servo motor	
EMMS-AS-70-...	1202331 EAMM-A-N38-70A
ELGA-TB-...-80	
With servo motor	
EMMS-AS-100-...	1201894 EAMM-A-N48-100A
ELGA-TB-...-120	
With servo motor	
EMMS-AS-140-...	1201691 EAMM-A-N80-140A

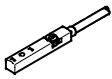
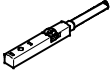
Gear unit	Motor	Axial kit
		
		Part No. Type
5/6 Permissible axis/motor combination with axial kit – Technical data online: → eamm-a		
ELGA-TB-...-70		
With servo motor		
EMGA-60-P-G3-SAS-70	EMMS-AS-70-...	1202253 EAMM-A-N38-60G
ELGA-TB-...-80		
With servo motor		
EMGA-80-P-G3-SAS-70	EMMS-AS-70-...	1258793 EAMM-A-N48-80G
EMGA-80-P-G3-SAS-100	EMMS-AS-100-...	1258793 EAMM-A-N48-80G
ELGA-TB-...-120		
With servo motor		
EMGA-120-P-G3-SAS-140	EMMS-AS-140-...	1201695 EAMM-A-N80-120G

Accessories – Ordering data

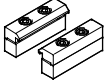
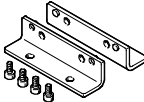
	For size	Part No.	Type	
7 Drive shaft				
	70	1344642	EAMB-24-9-15X21-16X20	
	80	558036	EAMB-24-6-15X21-16X20	
	120	558037	EAMB-34-6-25X26-23X27	
8 Slot cover¹⁾				
	70, 80	151681	ABP-5	
	120	151682	ABP-8	
9 Proximity sensor for T-slot, inductive				
N/O contact				Technical data → 759
	PNP, cable	551386	SIES-8M-PS-24V-K-7,5-OE	
	PNP, plug	551387	SIES-8M-PS-24V-K-0,3-M8D	
	NPN, cable	551396	SIES-8M-NS-24V-K-7,5-OE	
	NPN, plug	551397	SIES-8M-NS-24V-K-0,3-M8D	
N/C contact				Technical data → 759
	PNP, cable	551391	SIES-8M-PO-24V-K-7,5-OE	
	PNP, plug	551392	SIES-8M-PO-24V-K-0,3-M8D	
	NPN, cable	551401	SIES-8M-NO-24V-K-7,5-OE	
	NPN, plug	551402	SIES-8M-NO-24V-K-0,3-M8D	
10 Connecting cable				
Straight socket				Technical data → 949
	2.5 m	★	541333	NEBU-M8G3-K-2.5-LE3
	5 m	★	541334	NEBU-M8G3-K-5-LE3
Angled socket				Technical data → 949
	2.5 m	★	541338	NEBU-M8W3-K-2.5-LE3
	5 m	★	541341	NEBU-M8W3-K-5-LE3
11 Clip				
	70 ... 120		534254	SMBK-8
12 Slot nut				
	70, 80		150914	NST-5-M5
	120		150915	NST-8-M6
13 Profile mounting				
				Dimensions online: → elga
	70	★	558043	MUE-70/80
	80	★	558043	MUE-70/80
	120		558044	MUE-120/185
14 Foot mounting				
				Dimensions online: → elga
	70		558321	HPE-70
	80		558322	HPE-80
	120		558323	HPE-120

1) Packaging unit 2x 0.5 m.

Dimensions

Download CAD data → www.festo.com

3

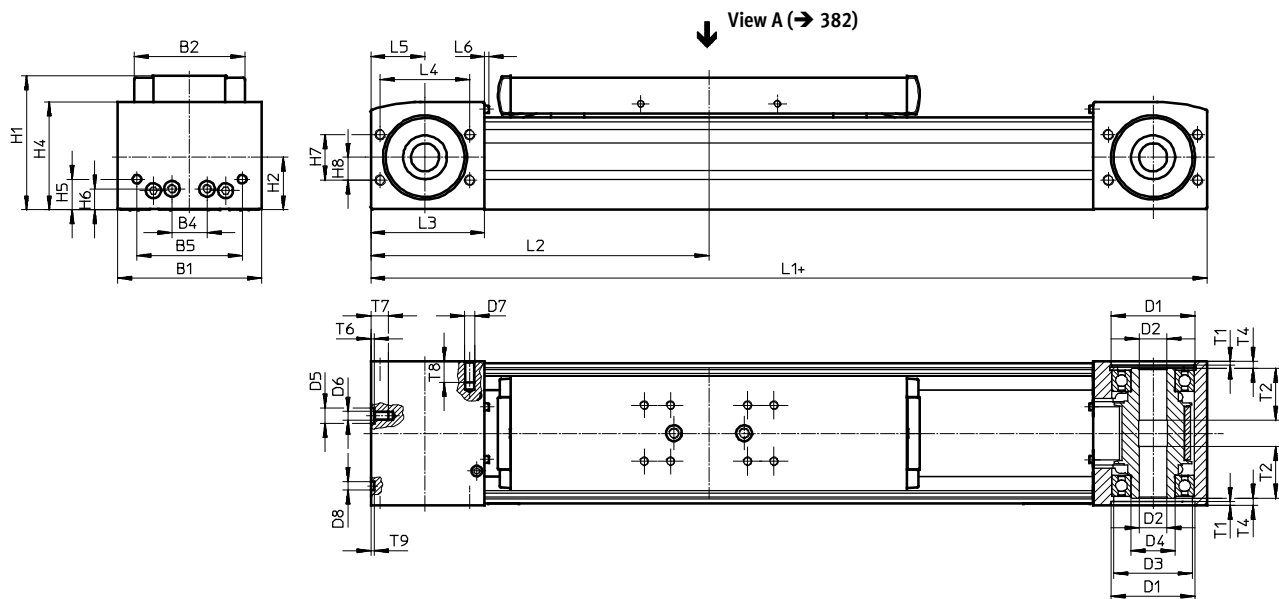

+ = plus stroke length + 2x stroke reserve

Size	B1	B2	B4	B5	D1	D2	D3	D4	D5	D6	D7
					H7	∅ H7	∅	∅	∅ H7		
70	69	48.2	30	45	38	16	34	25	–	M5	M6
80	82	63.2	20	60	48	16	45	25	9	M5	M6
120	120	95	80	40	80	23	72	45	–	M8	M8

Size	D8	H1	H2	H4	H5	H6	H7	H8	L1	L2	L3
	∅ H7									min.	
70	5	64	26.5	50.8	13	13	24	12	346	173	57.5
80	5	76.5	30	61.5	17.5	12	26	13	386	193	65
120	9	111.5	45	91	22	22	59	32	546	273	100

Size	L4	L5	L6	T1	T2	T4	T6	T7	T8	T9
70	42	27.5	2.3	2.1	18	7.15	–	10	12	3.1
80	51	31	2.3	2.1	29.5	4	2.1	10	12	2
120	76	50	2.5	3.1	29.5	4	–	16	16	2.1

Toothed belt axes ELGA-TB

Dimensions

Slide

Size 70

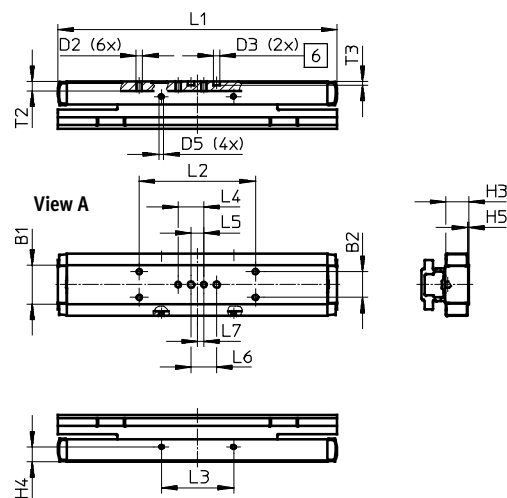

Size 80

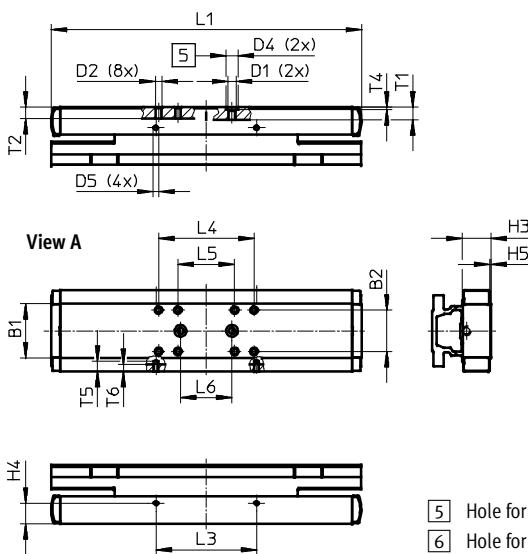

- 5 Hole for centring sleeve
- 6 Hole for centring pin

Size	B1	B2	B3	D1	D2	D3 ∅	D4 ∅	D5
70	30	20±0.1	-	-	M5	5 ^{H7}	-	M4
80	42	32±0.2	-	M6	M5	-	9 ^{H7}	M4

Size	H3	H4	H5	L1	L2	L3	L4	L5
		±0.1			±0.1	±0.1		
70	17.7	11.7	1	216.6	90	56	20±0.1	10±0.1
80	22.2	16	1	240.6	-	78	74±0.2	44±0.2

Size	L6	L7	T1	T2	T3	T4	T5	T6
	±0.03				+0.1	+0.1		
70	20	5	-	7.5	3.1	-	-	-
80	40	-	9.7	9	-	2.1	8	6

Dimensions

Slide

Size 120

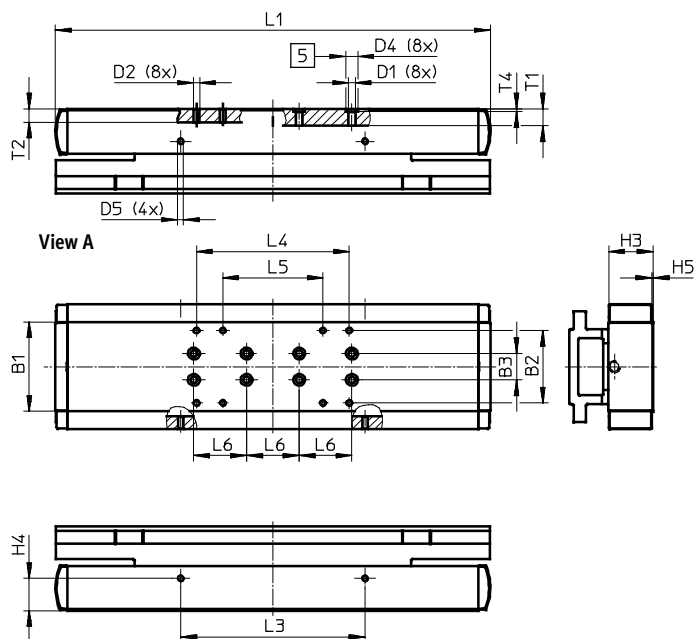

5 Hole for centring sleeve

Size	B1	B2	B3	D1	D2	D3 ∅	D4 ∅	D5
120	68	55±0.2	20±0.03	M6	M5	–	9H7	M5

Size	H3	H4	H5	L1	L2	L3	L4	L5
120	33.8	±0.1 24.5	1	330.4	±0.1 –	±0.1 140	116±0.2	76±0.2

Size	L6	L7	T1	T2	T3	T4	T5	T6
120	±0.03 40	–	12.8	10	+0.1 –	+0.1 2.1	–	–

3

Toothed belt axes ELGR

3

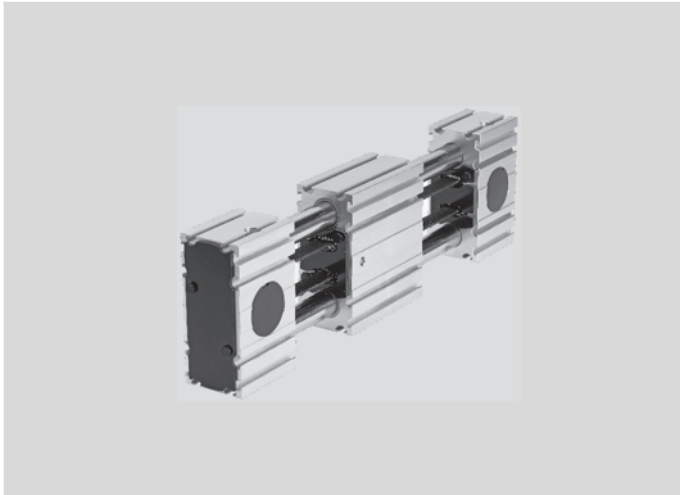

- Ready-to-install unit for quick and easy design
- Motor can be mounted on any of four sides – for every installation situation
- Highly reliable
- Kit for easy and space-saving position sensing
- Spare parts service

→ www.festo.com/catalogue/elgr

Product range overview

Type/version	Size	Stroke [mm]	Feed force [N]
ELGR			
Recirculating ball bearing guide	35, 45, 55	50 ... 1,500	50 ... 350
GF – Plain-bearing guide	35, 45, 55	50 ... 1,500	50 ... 350
ELFR			
Passive guide axis	35, 45, 55	50 ... 1,500	–

Product options

L Long slide

ZR 1 slide on right

ZL 1 slide on left

ZB 1 slide on right, 1 slide on left

Technical data

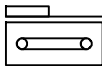

Technical data

Dimensions → 388

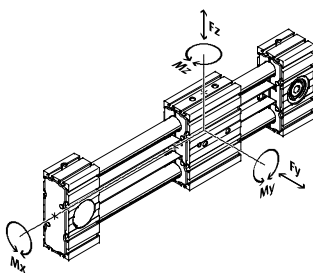

Guide	Plain-bearing guide			Recirculating ball bearing guide			
	Size	35	45	55	35	45	55
Working stroke ¹⁾	[mm]	50 ... 800	50 ... 1,000	50 ... 1,500	50 ... 800	50 ... 1,000	50 ... 1,500
Max. feed force F_x	[N]	50	100	350	50	100	350
Max. no-load torque	[Nm]	0.1	0.2	0.4	0.1	0.2	0.4
Max. driving torque	[Nm]	0.46	1.24	5	0.46	1.24	5
Max. no-load resistance to shifting	[N]	10.8	16.1	27.9	10.8	16.1	27.9
Max. speed	[m/s]	1			3		
Max. acceleration ²⁾	[m/s ²]	50			50		
Repetition accuracy	[mm]	±0.1			±0.1		
Max. permissible force F_y	[N]	50	100	300	50	100	300
Max. permissible force F_z	[N]	50	100	300	50	100	300
Max. permissible torque M_x	[Nm]	1	2.5	5	2.5	5	15
Max. permissible torque M_y	[Nm]	4	8	16	8	16	48
Max. permissible torque M_z	[Nm]	4	8	16	8	16	48

Note
PositioningDrives
sizing software
→ www.festo.com

1) Total stroke = working stroke + 2x stroke reserve.
2) The max. acceleration is dependent on the moving load, the driving torque and the max. feed force.

Operating conditions

Ambient temperature		
Recirculating ball bearing guide	[°C]	–10 ... +50
Plain-bearing guide	[°C]	0 ... +40
Protection class		IP20

Technical data

Toothed belt		35	45	55
Size		35	45	55
Pitch	[mm]	2	3	3
Expansion ¹⁾	[%]	0.094	0.08	0.21
Width	[mm]	10	15	19.3
Effective diameter	[mm]	18.46	24.83	28.65
Feed constant	[mm/ rev.]	58	78	90

1) At max. feed force.

Mass moment of inertia		35	45	55
Size		35	45	55
J_0				
Standard slide	[kg mm ²]	40.26	155.13	360.48
J_S per metre stroke	[kg mm ² /m]	0.26	1.06	1.88
J_L per kg effective load	[kg mm ² /kg]	85.19	154.13	205.21

The mass moment of inertia J_A of the entire axis is calculated as follows:

$$J_A = J_0 + J_S \times \text{working stroke [m]} + J_L \times m_{\text{effective load [kg]}}$$

Materials	
Drive cover	Anodised wrought aluminium alloy
Profile	Anodised wrought aluminium alloy
Slide	Anodised wrought aluminium alloy
Pulleys	High-alloy stainless steel
Toothed belt clamping component	Beryllium bronze
Toothed belt	Polychloroprene with glass cord and nylon coating

Order code

		ELGR	-	TB	-		-		-		-	
Type												
ELGR	Linear axis											
Drive function												
TB	Toothed belt											
Guide												
-	Recirculating ball bearing guide											
GF	Plain-bearing guide											
Size												
	Stroke [mm]											
35	50 ... 800											
45	50 ... 1,000											
55	50 ... 1,500											
Stroke reserve												
...H	0 ... 999 (0 = no stroke reserve)	1										

1) The sum of the nominal stroke and 2x stroke reserve must be at least 50 mm and must not exceed the maximum stroke length.

Toothed belt axes ELGR

Ordering – Product options

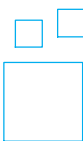

Configurable product

This product and all its options can be ordered using the configurator.

The configurator can be found under Products on the DVD or
 → www.festo.com/catalogue/...

Enter the type code in the search field.

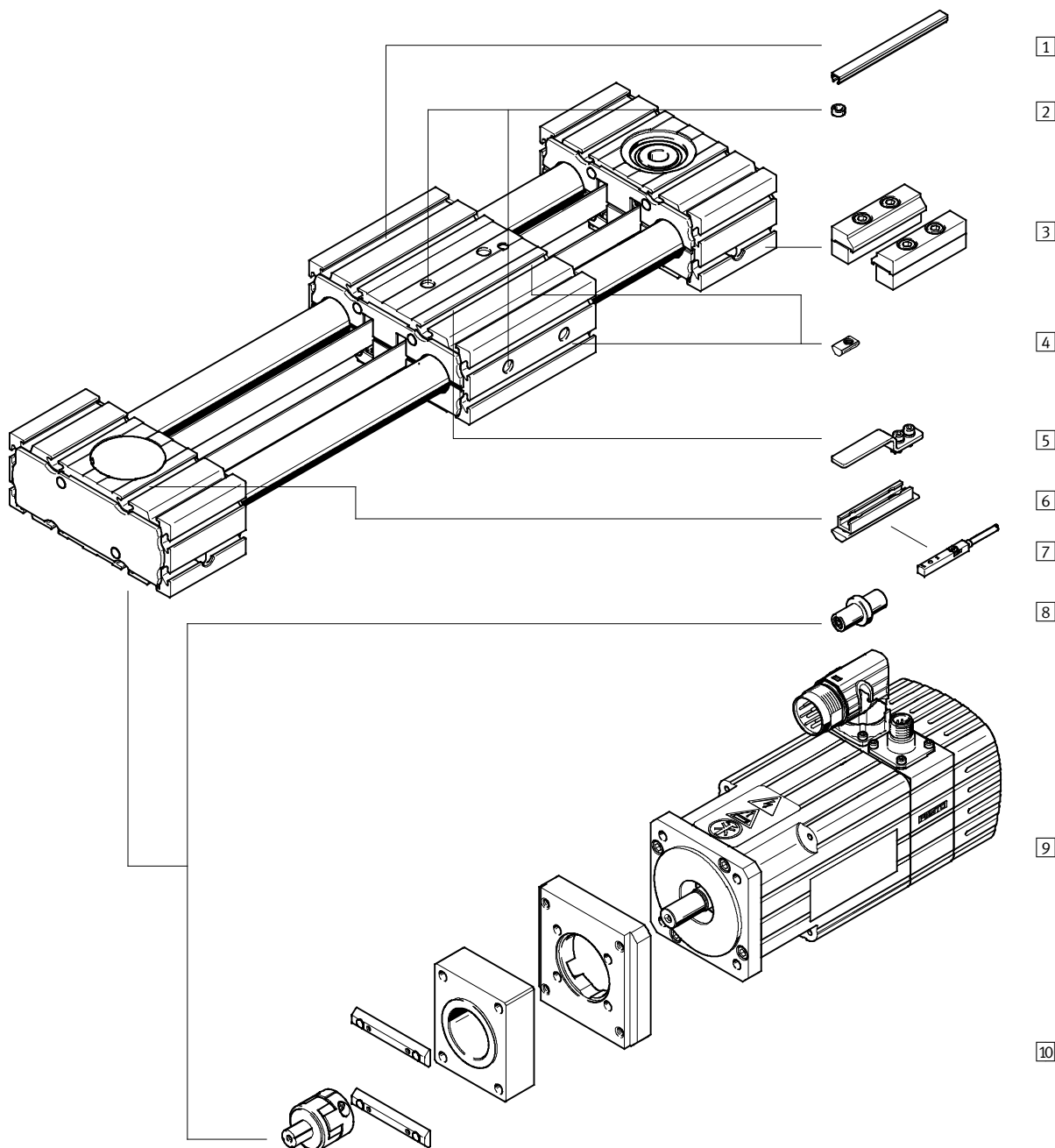

3 Accessories





		→ Page/online
1	Slot cover ABP	387
2	Centring sleeve ZBH	387
3	Profile mounting MUE	387
4	Slot nut NST	387
5	Switch lug EAPM	387
6	Sensor bracket EAPM	387

		→ Page/online
7	Inductive proximity sensor SIES	387
8	Drive shaft EAMB	387
9	Motor EMMS	387
10	Axial kit EAMM	387
-	Connecting cable NEBU	387

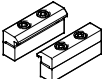
Accessories – Ordering data

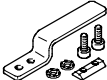
	For size	Part No.	Type
1 Slot cover¹⁾			
	45, 55	151681	ABP-5
2 Centring sleeve²⁾³⁾ Technical data online: → zbh			
	35, 45, 55	186717	ZBH-7
3 Profile mounting Dimensions online: → elgr			
	35	558042	MUE-50
	45, 55	562238	MUE-45

	For size	Part No.	Type
4 Slot nut			
	35	558045	NST-3-M3
	45, 55	150914	NST-5-M5
5 Switch lug Dimensions online: → elgr			
	35, 45, 55	567538	EAPM-L4-SLS
6 Sensor bracket Dimensions online: → elgr			
	35, 45, 55	567537	EAPM-L4-SHS

- 1) Packaging unit 2x 0.5 m.
- 2) Packaging unit 10 pieces.
- 3) 2 centring sleeves included in the scope of delivery of the axis.

	For size	Part No.	Type
7 Proximity sensor for T-slot, inductive, N/O contact Technical data → 759			
	PNP, cable	551386	SIES-8M-PS-24V-K-7,5-OE
	PNP, plug	551387	SIES-8M-PS-24V-K-0,3-M8D
	NPN, cable	551396	SIES-8M-NS-24V-K-7,5-OE
	NPN, plug	551397	SIES-8M-NS-24V-K-0,3-M8D
N/C contact Technical data → 759			
	PNP, cable	551391	SIES-8M-PO-24V-K-7,5-OE
	PNP, plug	551392	SIES-8M-PO-24V-K-0,3-M8D
	NPN, cable	551401	SIES-8M-NO-24V-K-7,5-OE
	NPN, plug	551402	SIES-8M-NO-24V-K-0,3-M8D
8 Drive shaft			
	35	558034	EAMB-16-7-8X15-8X10
	45	558035	EAMB-18-9-8X16-10X12
	55	558036	EAMB-24-6-15X21-16X20
Connecting cable, straight socket Technical data → 949			
	2.5 m	★ 541333	NEBU-M8G3-K-2.5-LE3
	5 m	★ 541334	NEBU-M8G3-K-5-LE3
Angled socket Technical data → 949			
	2.5 m	★ 541338	NEBU-M8W3-K-2.5-LE3
	5 m	★ 541341	NEBU-M8W3-K-5-LE3

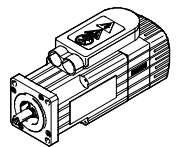
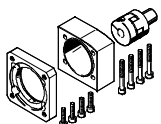
Motor	Axial kit	Part No.	Type
			
9/10 Permissible axis/motor combination with axial kit – Technical data online: → eamm-a			
ELGR-35			
With servo motor			
EMMS-AS-55-...	1133400	EAMM-A-R27-55A	
With stepper motor			
EMMS-ST-57-...	1133403	EAMM-A-R27-57A	

	Part No.	Type
ELGR-45		
With servo motor		
EMMS-AS-70-...	1133401	EAMM-A-R38-70A
With stepper motor		
EMMS-ST-57-...	1578138	EAMM-A-R38-57A
EMMS-ST-87-...	1133404	EAMM-A-R38-87A
ELGR-55		
With servo motor		
EMMS-AS-70-...	1578139	EAMM-A-R48-70A
EMMS-AS-100-...	1133402	EAMM-A-R48-100A
With stepper motor		
EMMS-ST-87-...	1133405	EAMM-A-R48-87A

Toothed belt axes ELGR

Dimensions

Download CAD data → www.festo.com

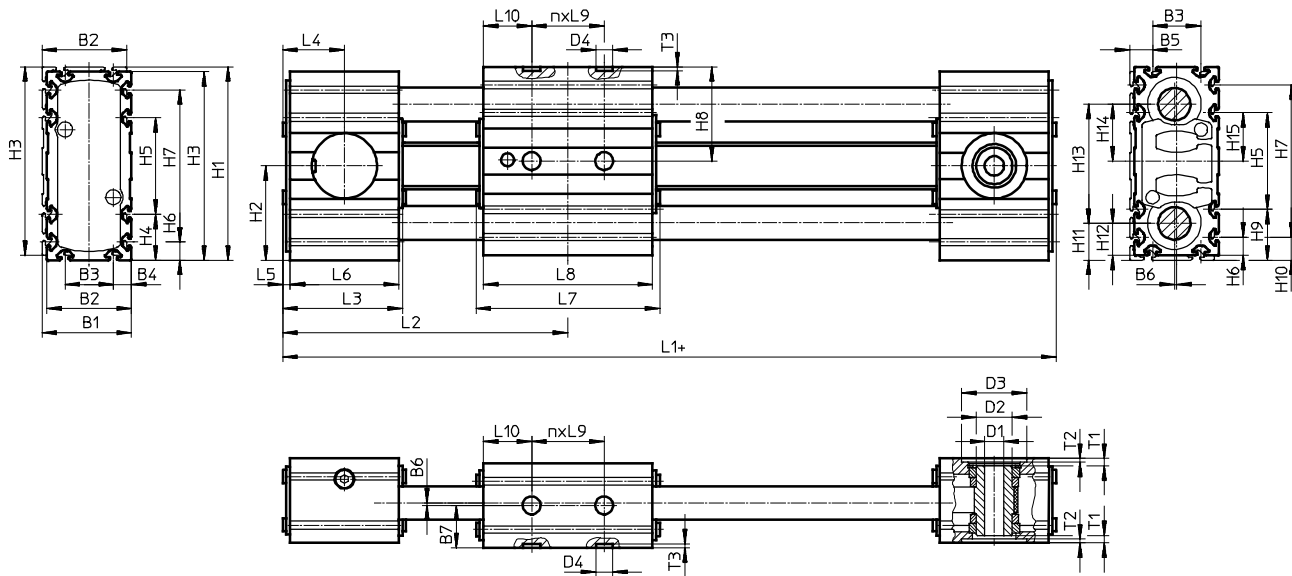

+ plus stroke + 2x stroke reserve

Type	B1	B2	B3	B4	B5	B6	B7	D1 ∅ H7	D2 ∅	D3 ∅ H7
ELGR-35	37	35	20	7.5	9.5	1	17.5	8	15	27
ELGR-45	47	45	20	12.5	14.5		22.5	10	20	38
ELGR-55	57	55	30	12.5	14.5		27.5	16	25	48

Type	D4 ∅ H7	H1	H2	H3	H4	H5	H6	H7	H8	H9
ELGR-35	7	80	39	78	19	40	7.5	63	39	21
ELGR-45		117	57.5	115	32.5	50	12.5	90	57.5	34.5
ELGR-55		137	67.5	135	32.5	70	12.5	110	67.5	34.5

Type	H10	H11	H12	H13	H14	H15	L1	L2	L3	L4
ELGR-35	9.5	15.5	13.5	49	23.5	20	178	89	51	25.5
ELGR-45	14.5	23	21	71	34.5	25	219	108	60	30
ELGR-55	14.5	25.5	23.5	86	42	35	243	120	62	31

Type	L5	L6	L7	L8	L9	L10	n	T1	T2	T3
ELGR-35	3	45	76	70	30	20	1	3.1	1.6	+0.1
ELGR-45		54	96	90	40	25	1	3	1.7	1.6
ELGR-55		56	116	110	40	35	1	4.5	2	1.6



- Freely positionable
- Any rotation angle
- Position sensing with inductive proximity sensors
- Definition of non-operational areas with sensing module
- Spare parts service

3

→ www.festo.com/catalogue/ermb

Product range overview

Type/version	Size	Rotation angle [°]	Driving torque [Nm]	Output torque [Nm]
ERMB				
Rotary module	20, 25, 32	Infinite	0.7 ... 8.5	3.15 ... 25.5

Technical data

Technical data				Dimensions → 393
Size		20	25	32
Drive shaft Ø	[mm]	6	8	12
Rotation angle		Infinite		
Repetition accuracy ¹⁾				
With servo motor EMMS-AS	[°]	±0.03		
With stepper motor EMMS-ST ²⁾	[°]	±0.08		
With motor unit MTR-DCI	[°]	±0.05		
Gear ratio		4.5:1	4:1	3:1
Max. driving torque	[Nm]	0.7	2.2	8.5
Max. output torque ³⁾	[Nm]	3.15	8.8	25.5
No-load driving torque ⁴⁾	[Nm]	< 0.07	< 0.18	≤ 0.5
Max. input speed	[rpm]	1,350	1,200	900
Max. output speed	[rpm]	300	300	300
Max. mass moment of inertia ⁵⁾				
With servo motor EMMS-AS	[kgcm ²]	50	200	1,000
With stepper motor EMMS-ST	[kgcm ²]	30	100	500
With motor unit MTR-DCI-...-G7	[kgcm ²]	50	300	1,000
With motor unit MTR-DCI-...-G14	[kgcm ²]	200	1,200	3,700

1) As per FN 942 027.

2) Dependent on the encoder resolution.

3) Output torque minus friction dependent on speed.

4) At maximum speed.

5) Dependent on the size of the motor. Suitable motors → 392.

Note

Note the maximum permissible driving torque of the rotary module ERMB. The motor current may need to be limited.

Operating conditions

Ambient temperature ⁶⁾	[°C]	-10 ... +60
Protection class		IP20

6) Note operating range of proximity sensors.

Technical data

Materials	
End cap	Anodised wrought aluminium alloy
Output shaft	Anodised wrought aluminium alloy
Housing	Anodised wrought aluminium alloy
Drive shaft	High-alloy stainless steel
Toothed belt	Polychloroprene with glass fibres

3

Order code

ERMB	

Type	
ERMB	Rotary module

Size	
20	Size 20
25	Size 25
32	Size 32

Ordering – Product options

Configurable product

This product and all its options can be ordered using the configurator.

The configurator can be found under Products on the DVD or
[→ www.festo.com/catalogue/...](http://www.festo.com/catalogue/...)



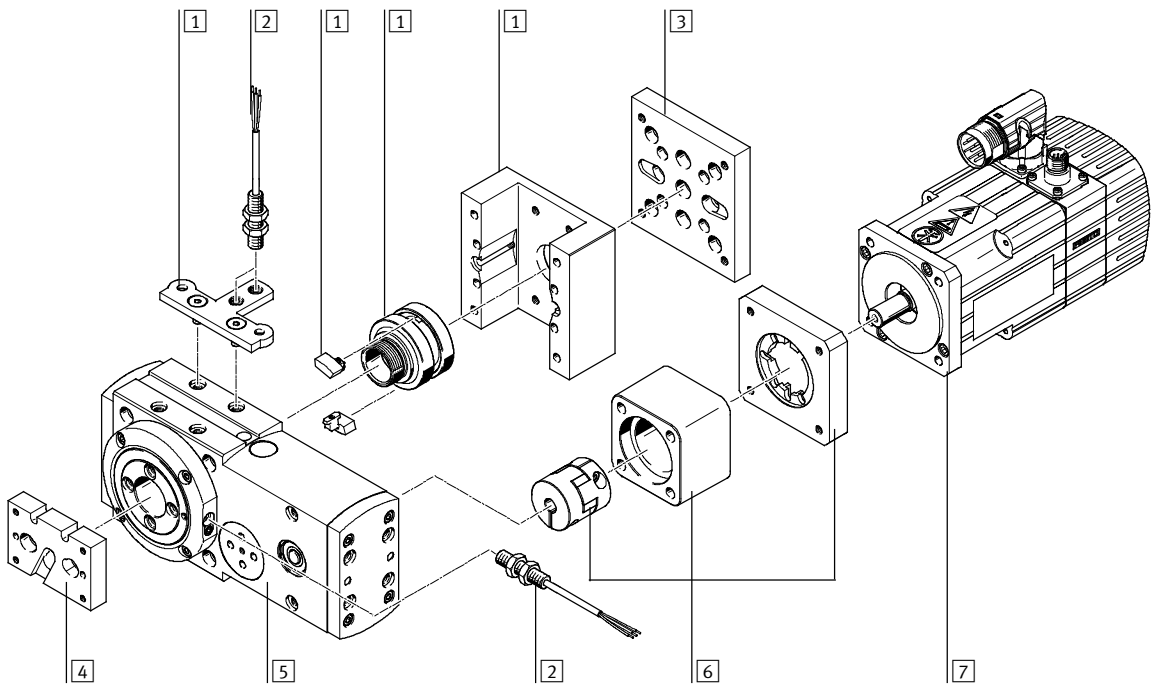

Enter the type code in the search field.



Accessories

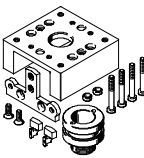

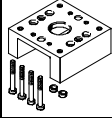

		→ Page/online
1	Sensing kit EAPS	391
2	Inductive proximity sensor SIEN	391
3	Drive/drive connections	adapter kit
4	Drive/gripper connections	adapter kit
5	Rotary module ERMB	389
6	Axial kit EAMM-A	392
7	Motor EMMS/motor unit MTR-DCI	392

Accessories – Ordering data

	For size	Part No.	Type
1 Sensing kit Technical data online: → eamm-a			
	20	558392	EAPS-R1-20-S
	25	558393	EAPS-R1-25-S
	32	558394	EAPS-R1-32-S
Sensing kit without housing			
	20	558395	EAPS-R1-20-S-WH
	25	558396	EAPS-R1-25-S-WH
	32	558397	EAPS-R1-32-S-WH
Cam			
	20, 25, 32	558398	EAPS-R1-CK
Sensor bracket			
	20, 25	558399	EAPS-R1-20-SH
	32	558400	EAPS-R1-32-SH

	For size	Part No.	Type
Housing			
	20	560673	EAPS-R1-20-H
	25	560674	EAPS-R1-25-H
	32	560675	EAPS-R1-32-H
Centring sleeve¹⁾ Technical data online: → zbh			
	20	186717	ZBH-7
	25, 32	150927	ZBH-9
2 Connecting cable, straight socket Technical data → 949			
	2.5 m	★ 541333	NEBU-M8G3-K-2.5-LE3
	5 m	★ 541334	NEBU-M8G3-K-5-LE3

1) Packaging unit 10 pieces.

	For size	Connection	Part No.	Type
	20, 25, 32	Cable	★ 150386	SIEN-M8B-PS-K-L
		Plug	★ 150387	SIEN-M8B-PS-S-L
	20, 25, 32	Cable	150390	SIEN-M8B-PO-K-L
		Plug	150391	SIEN-M8B-PO-S-L

3

Accessories – Ordering data

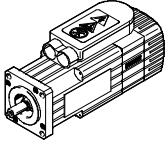
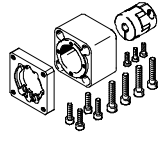
Motor/motor unit	Axial kit	
		
	Part No.	Type
[6/7] Permissible axis/motor combinations with axial kit –		
Technical data online: → eamm-a		
ERMB-20		
With servo motor		
EMMS-AS-40-...	560281	EAMM-A-D32-35A-40A
With stepper motor		
EMMS-ST-42-...	★ 543148	EAMM-A-D32-42A
EMMS-ST-57-...	★ 550980	EAMM-A-D32-57A
With motor unit		
MTR-DCI-32S-...	★ 543149	EAMM-A-D32-32B
ERMB-25		
With servo motor		
EMMS-AS-55-...	★ 543153	EAMM-A-D40-55A
EMMS-AS-70-...	★ 550981	EAMM-A-D40-70A
With stepper motor		
EMMS-ST-57-...	★ 543154	EAMM-A-D40-57A
With motor unit		
MTR-DCI-42S-...-G7	★ 543155	EAMM-A-D40-42B
MTR-DCI-42S-...-G14	★ 543156	EAMM-A-D40-42C
ERMB-32		
With servo motor		
EMMS-AS-70-...	★ 543161	EAMM-A-D60-70A
EMMS-AS-100-...	★ 550983	EAMM-A-D60-100A
With stepper motor		
EMMS-ST-87-...	★ 543162	EAMM-A-D60-87A
With motor unit		
MTR-DCI-52S-...-G7	★ 543163	EAMM-A-D60-52B
MTR-DCI-52S-...-G14	★ 543164	EAMM-A-D60-52C

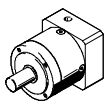
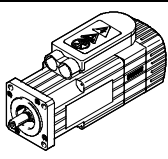
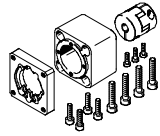
Gear unit	Motor	Axial kit	
			
		Part No.	Type
[6/7] Permissible axis/motor combinations with axial kit –			
Technical data online: → eamm-a			
ERMB-25			
With servo motor			
EMGA-40-P-G3-SAS-40	EMMS-AS-40-...	560282	EAMM-A-D40-40G
ERMB-32			
With servo motor			
EMGA-60-P-G...-SAS-55	EMMS-AS-55-...	560283	EAMM-A-D60-60G
EMGA-60-P-G3-SAS-70	EMMS-AS-70-...	560283	EAMM-A-D60-60G
With stepper motor			
EMGA-60-P-G...-SST-57	EMMS-ST-57-...	560283	EAMM-A-D60-60G

Dimensions

Basic design – Size 20

3

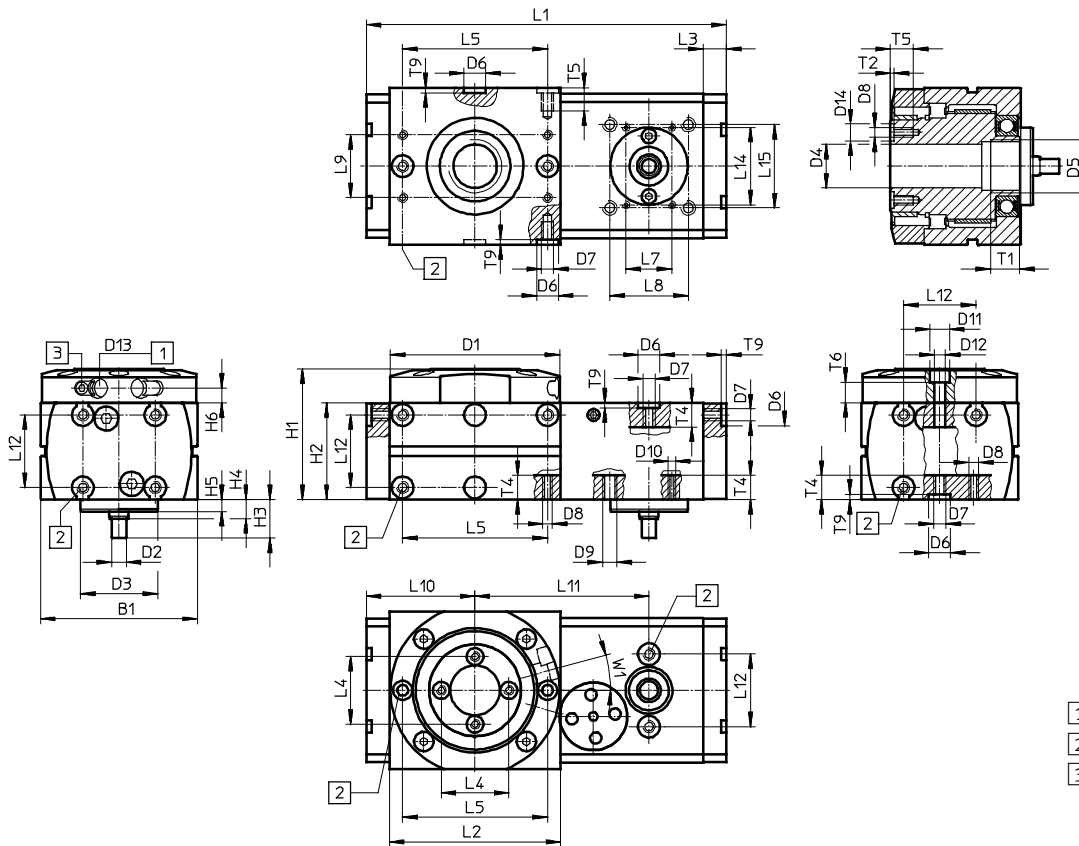

- 1 Thread for reference switch
- 2 Mounting options
- 3 Clamping component, width across flats 2.5 (enclosed separately)

Size	B1	D1	D2	D3	D4	D5	D6	D7	D8	D9	D10	D11	D12	D13
	±0.2	∅ f9	∅ h6	∅ g7	H7		∅ H7					∅	∅	
20	65	70	6	32	20	M22x1	9	M5	M4	M6	M3	8	4.5	M8x1

Size	D14	H1	H2	H3	H4	H5	H6	L1	L2	L3	L4 ¹⁾	L5 ¹⁾	L7	L8
	∅ H7	±0.5	±0.1					±0.5	±0.2	±0.1			±0.15	±0.15
20	7	54	40	15.9	7.9	5	6.15	149	71	9.5	28	60	19	32.5

Size	L9 ¹⁾	L10	L11	L12 ¹⁾	L14	L15	T1	T2	T4	T5	T6	T9	W1
			±0.05		±0.15	±0.15		+0.1		min.		+0.2	
20	26	45	72	30	32	32.5	12	1.6	10	9.6	8.4	2.1	15°

1) Tolerance for centring hole ±0.02 mm.
 Tolerance for thread ±0.1 mm.

Rotary modules ERMB, electric

Dimensions

Basic design – Size 25/32

Size 32

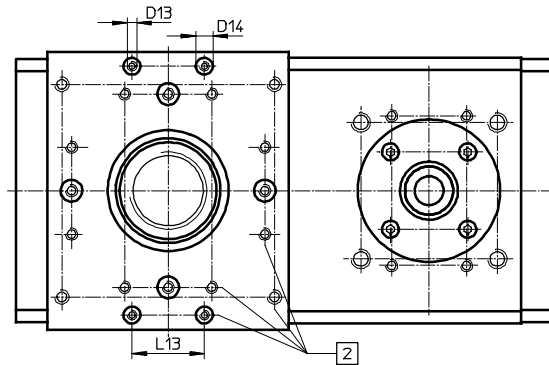

Size 25/32

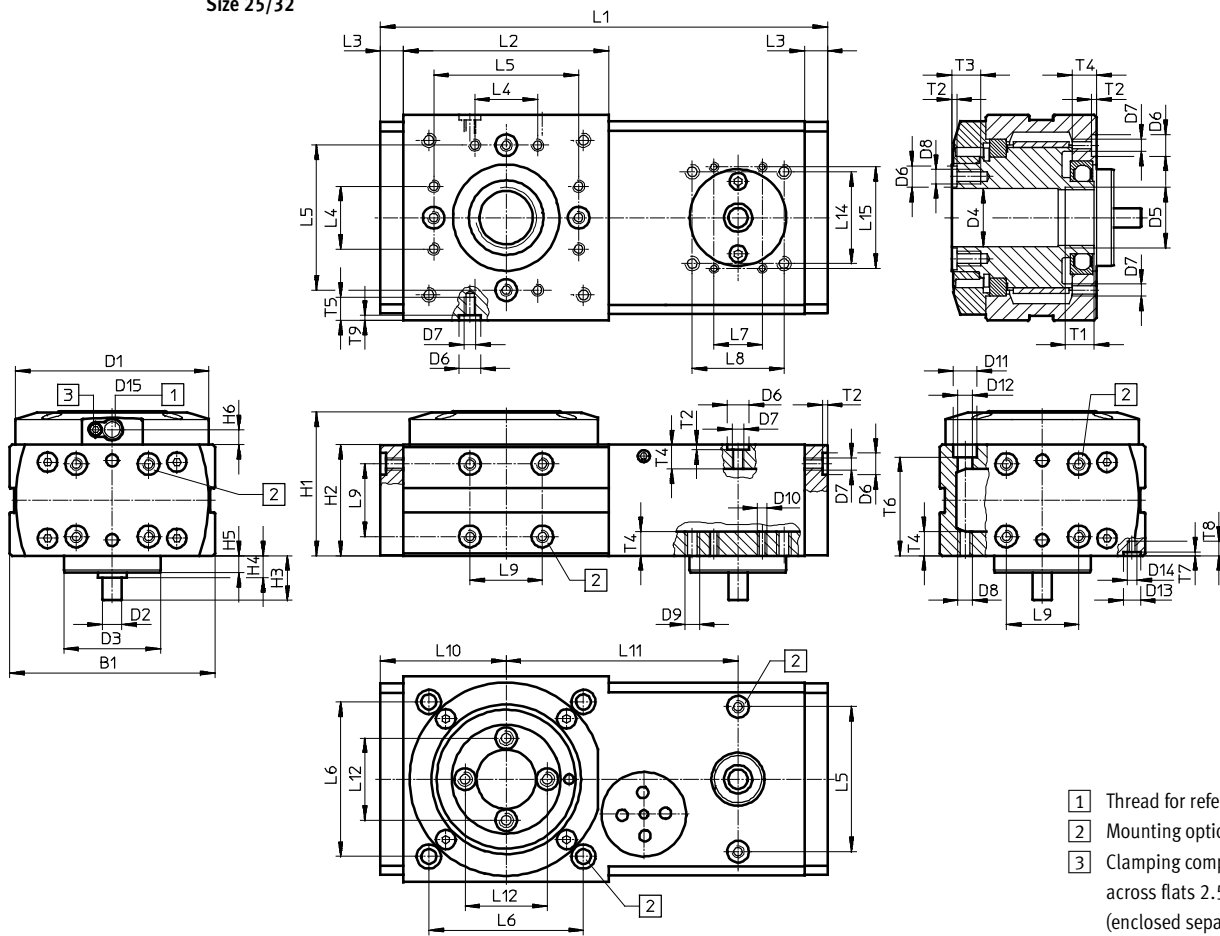

- 1 Thread for reference switch
- 2 Mounting options
- 3 Clamping component, width across flats 2.5 (enclosed separately)

Dimensions

Download CAD data → www.festo.com

Size	B1 ±0.2	D1 ∅ f9	D2 ∅ h6	D3 ∅ g7	D4 ∅ H7	D5	D6 ∅ H7	D7	D8	D9	D10
25	85	80	8	40	24	M25x1	9	M5	M6	M6	M4
32	115	112	12	60	28	M32x1.5	9	M5	M6	M8	M5

Size	D11 ∅	D12 ∅	D13 ∅ H7	D14	D15	H1 ±0.5	H2 ±0.1	H3	H4	H5	H6	L1 ±0.5
25	10	6.2	–	–	M8x1	60	46	18.45	–	7	6.3	185
32	10	6.2	7	M4	M8x1	76.05	60	23.5	6.5	6	9.4	222

Size	L2 ±0.2	L3 ±0.1	L4 ±0.1	L5 ¹⁾	L6	L7 ±0.15	L8 ±0.15	L9 ¹⁾	L10	L11 ±0.05	L12 ¹⁾	L13 ¹⁾
25	85	9.5	26	60	64 ±0.15	20	38	30	52	96	34	–
32	100	13	36	80	88 ±0.1	31	56.5	40	63	108	45	30

Size	L14 ±0.15	L15 ±0.15	T1	T2 +0.1	T3 min.	T4	T5 min.	T6	T7 +0.1	T8 min.	T9 +0.2
25	38	42	12	2.1	12	10	9.6	40.8±0.2	–	–	2.1
32	56.5	62	12	2.1	12	10	10	54.3	1.6	7.6	2.1

1) Tolerance for centring hole ±0.02 mm.
Tolerance for thread ±0.1 mm.

Rotary lifting modules EHMB, electric

3

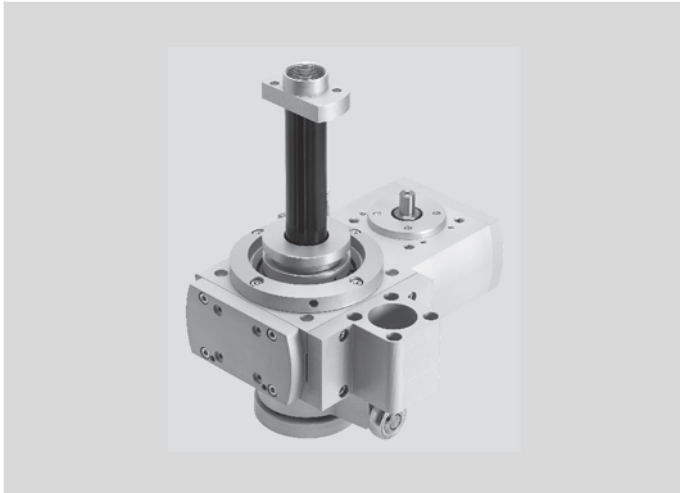

- Combined and configurable rotary lifting movement
- Linear and rotary movements can be set independently of each other
- Modular drive concept for linear motion
- Simple and convenient laying of energy cables by means of hollow shaft with large internal diameter

→ www.festo.com/catalogue/ehmb

Product range overview

Type/version	Size	Drive shaft Ø	Stroke [mm]	Rotation angle	Output torque [Nm]	Effective load [kg]
EHMB						
Rotary lifting module	20, 25, 32	6, 8, 12	100, 200	Infinite	3.15 ... 20	3 ... 15

Complete system consisting of rotary lifting module, motor and axial kit

Rotary lifting module

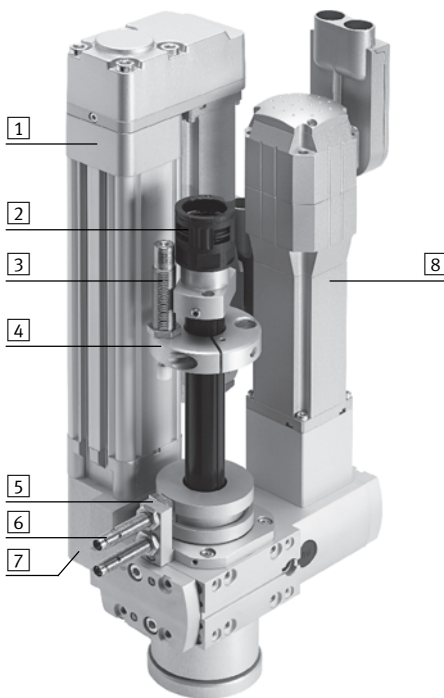

- 1) Electric cylinder DNCE, alternatively standard cylinder DNC¹⁾
- 2) Protective conduit fitting¹⁾
- 3) Shock absorber¹⁾
- 4) Shock absorber retainer¹⁾
- 5) Sensor bracket
- 6) Proximity sensor SIEN¹⁾
- 7) Cylinder retainer
- 8) Motor for rotary movement¹⁾

1) These parts must be ordered separately as accessories.

Technical data

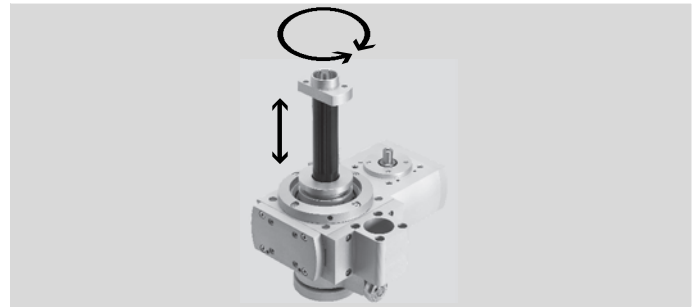

3

Technical data		Dimensions → 406		
Size		20	25	32
Drive shaft Ø	[mm]	6	8	12
Rotation angle		Infinite (→ 397)		
Stroke, linear	[mm]	100, 200		
Repetition accuracy, rotary ¹⁾				
With servo motor EMMS-AS	[°]	±0.03		
With stepper motor EMMS-ST ²⁾	[°]	±0.08		
With motor unit MTR-DCI	[°]	±0.05		
Repetition accuracy, linear ¹⁾	[mm]	±0.02		
Max. speed, linear				
With standard cylinder DNC	[m/s]	1.5		
With electric cylinder DNCE	[m/s]	0.5		0.64
Gear ratio		4.5:1	4:1	3:1
Max. driving torque	[Nm]	0.7	2.2	6.7
Max. output torque ³⁾	[Nm]	3.15	8.8	20
No-load driving torque ⁴⁾	[Nm]	< 0.07	< 0.18	< 0.5
Max. input speed	[rpm]	1,350	1,200	900
Max. output speed	[rpm]	300	300	300
Max. effective load, horizontal	[kg]	3	5	8
Max. effective load, vertical	[kg]	3	5	15 ⁵⁾
Max. mass moment of inertia ⁶⁾				
With servo motor EMMS-AS	[kgcm ²]	50	200	1,000
With stepper motor EMMS-ST	[kgcm ²]	30	100	500
With motor unit MTR-DCI-...-G7	[kgcm ²]	50	300	1,000
With motor unit MTR-DCI-...-G14	[kgcm ²]	200	1,200	3,700
Toothed belt pitch		2	3	5

- 1) As per FN 942 027, with electric cylinder DNCE.
- 2) Dependent on the encoder resolution.
- 3) Output torque minus friction dependent on speed.
- 4) At maximum speed.
- 5) With symmetrical and non-eccentric arrangement.
- 6) Dependent on the size of the motor. Suitable motors → 403

Note

When laying electrical cables or compressed air tubing through the hollow shaft of the grooved-shaft guide, the

rotation angle of the EHMB must be limited to a rotation angle appropriate to the cables or compressed air tubing.

Endless rotation damages cables and tubing.

All values are based on a room temperature of 23 °C.

Rotary lifting modules EHMB, electric

Technical data

Operating conditions				
Size		20	25	32
Ambient temperature ¹⁾	[°C]	-10 ... +60		

1) Note operating range of proximity sensors.

3

Materials	
Flange	Anodised aluminium
Retainer	Anodised aluminium
Holder	Anodised wrought aluminium alloy
End cap	Anodised wrought aluminium alloy
Output shaft	Steel
Housing	Anodised wrought aluminium alloy
Drive shaft	High-alloy stainless steel
Toothed belt	Polychloroprene with glass fibres

Order code

EHMB	-		-	
------	---	--	---	--

Type
EHMB Rotary lifting module, electric

Size
20, 25, 32

Stroke [mm]
100, 200

Ordering – Product options



Configurable product



This product and all its options can be ordered using the configurator.

The configurator can be found under Products on the DVD or
[→ www.festo.com/catalogue/...](http://www.festo.com/catalogue/...)

Enter the type code in the search field.

Accessories

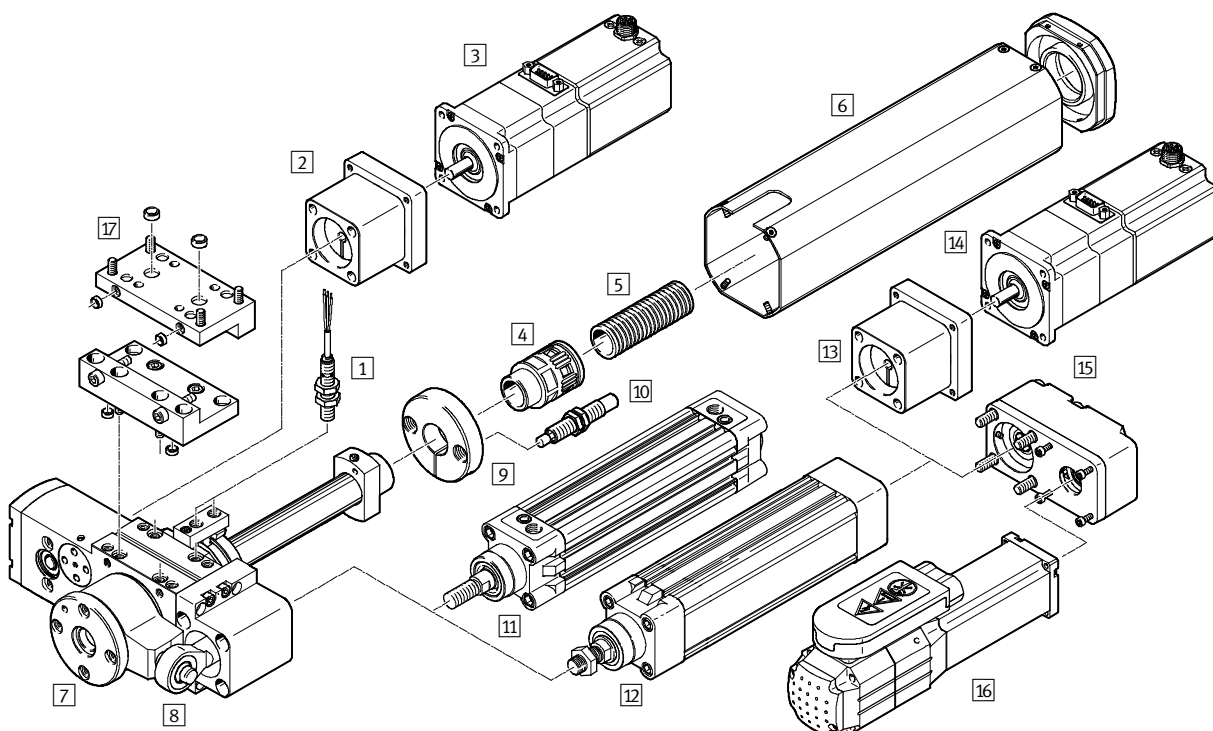

3

		→ Page/online
1	Proximity sensor SIEN	405
2	Axial kit EAMM-A, for the rotary movement of the rotary/lifting module	403
3	Motor EMMS, MTR-DCI, for the rotary movement of the rotary/lifting module	403
4	Protective conduit fitting EASA	405
5	Protective conduit MKR	405
6	Cover EASC	405
7	Rotary/lifting module EHMB	396
8	Rod eye SGS	405
9	Shock absorber retainer EAYH	405
10	Shock absorber DYSW	405
11	Standard cylinder DNC, pneumatic drive for the linear movement of the rotary/lifting module	400

		→ Page/online
12	Electric cylinder DNCE, electric drive for the linear movement of the rotary/lifting module	400
13	Axial kit EAMM-A, for the linear movement of the rotary/lifting module	400
14	Motor EMMS, MTR-DCI, for the linear movement of the rotary/lifting module	400
15	Parallel kit EAMM-U, for the linear movement of the rotary/lifting module	401
16	Motor EMMS, MTR-DCI, for the linear movement of the rotary/lifting module	400
17	Adapter plate kit EHAM	405
-	Connecting cable NEBU	405
-	Centring sleeve ZBH	405
-	Cam EAPS	405

Accessories – Ordering data

Cylinder connection for linear movement

11 in combination with pneumatic standard cylinder DNC

Technical data online: → [dnc](#)

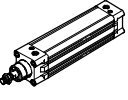
	For rotary/lifting module	Standard cylinder DNC	
		Part No.	Type
	EHMB-20-100	163309	DNC-32-100-PPV-A
	EHMB-20-200	163312	DNC-32-200-PPV-A
	EHMB-25-100	163309	DNC-32-100-PPV-A
	EHMB-25-200	163312	DNC-32-200-PPV-A
	EHMB-32-100	163341	DNC-40-100-PPV-A
	EHMB-32-200	163344	DNC-40-200-PPV-A

12 in combination with electric cylinder DNCE

Technical data → 314

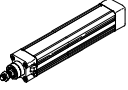
	For rotary/lifting module	Electric cylinder DNCE	
		Part No.	Type
	EHMB-20-100	★ 543115	DNCE-32-100-BS-”3”P-Q ¹⁾
	EHMB-20-200	★ 543116	DNCE-32-200-BS-”3”P-Q ¹⁾
	EHMB-25-100	★ 543115	DNCE-32-100-BS-”3”P-Q ¹⁾
	EHMB-25-200	★ 543116	DNCE-32-200-BS-”3”P-Q ¹⁾
	EHMB-32-100	★ 543127	DNCE-40-100-BS-”5”P-Q ²⁾
	EHMB-32-200	★ 543128	DNCE-40-200-BS-”5”P-Q ²⁾

12 in combination with electric cylinder DNCE

Technical data → 314

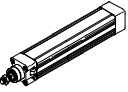
	For rotary/lifting module	Electric cylinder DNCE	
		Part No.	Type
	EHMB-20-100	★ 543119	DNCE-32-100-BS-”10”P-Q ³⁾
	EHMB-20-200	★ 543120	DNCE-32-200-BS-”10”P-Q ³⁾
	EHMB-25-100	★ 543119	DNCE-32-100-BS-”10”P-Q ³⁾
	EHMB-25-200	★ 543120	DNCE-32-200-BS-”10”P-Q ³⁾
	EHMB-32-100	★ 543131	DNCE-40-100-BS-”12,7”P-Q ⁴⁾
	EHMB-32-200	★ 543132	DNCE-40-200-BS-”12,7”P-Q ⁴⁾

- 1) Ball screw with spindle pitch 3 mm, with reduced dynamic response.
- 2) Ball screw with spindle pitch 5 mm, with reduced dynamic response.
- 3) Ball screw with spindle pitch 10 mm.
- 4) Ball screw with spindle pitch 12.7 mm.

Motor mounting for linear movement

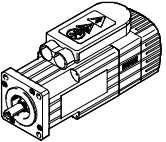
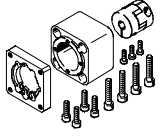
Motor	Axial kit
	
	Part No. Type

13/14 Permissible axis/motor combination with axial kit

Technical data online: → [eammm-a](#)

DNC-32			
With servo motor			
EMMS-AS-40-...	★	543147	EAMM-A-D32-40A
EMMS-AS-55-...	★	550979	EAMM-A-D32-55A
With stepper motor			
EMMS-ST-42-...	★	543148	EAMM-A-D32-42A
EMMS-ST-57-...	★	550980	EAMM-A-D32-57A
With motor unit			
MTR-DCI-32S-... ¹⁾	★	543149	EAMM-A-D32-32B

- 1) Only in combination with DNC-...-LS.

Accessories – Ordering data

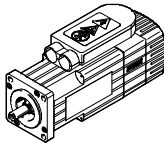
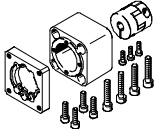
Motor mounting for linear movement		Axial kit	
Motor/motor unit		Axial kit	
			
Type		Part No.	Type
DNCE-40			
With servo motor			
EMMS-AS-55-...	★	543153	EAMM-A-D40-55A
EMMS-AS-70-...	★	550981	EAMM-A-D40-70A
With stepper motor			
EMMS-ST-57-...	★	543154	EAMM-A-D40-57A
EMMS-ST-87-...	★	550982	EAMM-A-D40-87A
With motor unit			
MTR-DCI-42S-...-G7 ¹⁾	★	543155	EAMM-A-D40-42B
MTR-DCI-42S-...-G14 ¹⁾	★	543156	EAMM-A-D40-42C

1) Only in combination with DNCE-...-LS.

Note

Depending on the combination of motor/ motor unit and rotary/lifting module, it may not be possible to reach the maximum feed force of the cylinder.

The following tool is available for sizing:
 PositioningDrives sizing software
 → www.festo.com

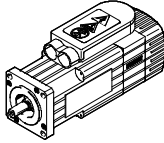
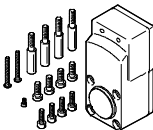
Motor mounting for linear movement		Parallel kit	
Motor/motor unit		Parallel kit	
			
Type		Part No.	Type
15/16 Permissible axis/motor combination with parallel kit			
Technical data online: → eamm-u			
DNCE-32			
With servo motor			
EMMS-AS-40-...	★	543150	EAMM-U-D32-40A
With motor unit			
MTR-DCI-32S-...		543152	EAMM-U-D32-32B
DNCE-40			
With servo motor			
EMMS-AS-55-...	★	543157	EAMM-U-D40-55A
With motor unit			
MTR-DCI-42S-...-G7		543159	EAMM-U-D40-42B
MTR-DCI-42S-...-G14		543160	EAMM-U-D40-42C

Note

Depending on the combination of motor/ motor unit and rotary/lifting module, it may not be possible to reach the maximum feed force of the cylinder. The

respective no-load driving torque of the kit must be taken into consideration when using parallel kits.

The following tool is available for sizing:
 PositioningDrives sizing software
 → www.festo.com

Accessories – Ordering data

Motor mounting for linear movement

Permissible axis/motor combination with parallel kit

Motor/motor unit

Parallel kit

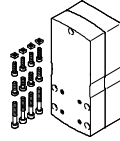
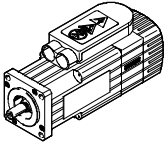

- Increased housing rigidity
- More flexible motor mounting possible
- Optionally with protection class IP65
- Use in combination with third-party motors on request

Part No. Type

DNCE-32**With servo motor**EMMS-AS-40-... ★ 1201591 EAMM-U-50-D32-40A-78¹⁾EMMS-AS-55-... ★ 1210126 EAMM-U-60-D32-55A-91²⁾**With stepper motor**EMMS-ST-42-... ★ 1201607 EAMM-U-50-D32-42A-78¹⁾EMMS-ST-57-... ★ 1210419 EAMM-U-60-D32-57A-91²⁾**With motor unit**MTR-DCI-32S-... 1570862 EAMM-U-50-D32-32B-78¹⁾**DNCE-40****With servo motor**

EMMS-AS-55-... ★ 1210438 EAMM-U-60-D40-55A-91

EMMS-AS-70-... ★ 1212826 EAMM-U-86-D40-70A-102³⁾**With stepper motor**

EMMS-ST-57-... ★ 1210442 EAMM-U-60-D40-57A-91

EMMS-ST-87-... ★ 1215802 EAMM-U-86-D40-87A-102³⁾**With motor unit**

MTR-DCI-42S-... 1570950 EAMM-U-60-D40-42B/C-91

1) The EAMM-U-50-... cannot be operated in combination with the cover EASC-H1 in all attachment positions.

2) The EAMM-U-60-... cannot be operated in combination with the cover EASC-H1 in all attachment positions.

3) The EAMM-U86-... cannot be operated in combination with the cover EASC-H1 in all attachment positions.

Note

The motor and/or axis shaft can optionally be supported with a counter bearing EAMG. [More information → eamm-u](#)

Accessories – Ordering data

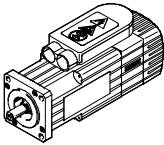
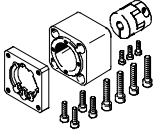
Motor mounting for rotary movement		Axial kit	
Motor/motor unit			
			
	Part No.	Type	
2/3 Permissible axis/motor combination with axial kit – Without gear unit			Technical data online: → eamm-a
EHMB-20			
With servo motor			
EMMS-AS-40-...	560281	EAMM-A-D32-35A-40A	
With stepper motor			
EMMS-ST-42-...	★ 543148	EAMM-A-D32-42A	
EMMS-ST-57-S-...	★ 550980	EAMM-A-D32-57A	
With motor unit			
MTR-DCI-32S-...	★ 543149	EAMM-A-D32-32B	
EHMB-25			
With servo motor			
EMMS-AS-55-...	★ 543153	EAMM-A-D40-55A	
EMMS-AS-70-S-...	★ 550981	EAMM-A-D40-70A	
With stepper motor			
EMMS-ST-57-...	★ 543154	EAMM-A-D40-57A	
With motor unit			
MTR-DCI-42S-...-G7	★ 543155	EAMM-A-D40-42B	
MTR-DCI-42S-...-G14	★ 543156	EAMM-A-D40-42C	
EHMB-32			
With servo motor			
EMMS-AS-70-...-	★ 543161	EAMM-A-D60-70A	
EMMS-AS-100-...-	★ 550983	EAMM-A-D60-100A	
With stepper motor			
EMMS-ST-87-...-	★ 543162	EAMM-A-D60-87A	
With motor unit			
MTR-DCI-52S-...-G7	★ 543163	EAMM-A-D60-52B	
MTR-DCI-52S-...-G14	★ 543164	EAMM-A-D60-52C	

3

Note

Note the maximum permissible driving torque of the EHMB. The motor current

may need to be limited.

The following tool is available for sizing:

PositioningDrives sizing software

[→ www.festo.com](http://www.festo.com)

Accessories – Ordering data

Motor mounting for rotary movement

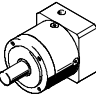
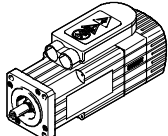
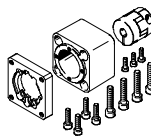
Gear unit	Motor	Axial kit	
			
Type		Part No.	Type
2/3 Permissible axis/motor combination with axial kit – With gear unit			Technical data online: → eamm-a
EHMB-25			
With servo motor			
EMGA-40-P-G3-SAS-40	EMMS-AS-40-...	560282	EAMM-A-D40-40G
EHMB-32			
With servo motor			
EMGA-60-P-G...-SAS-55	EMMS-AS-55-...	560283	EAMM-A-D60-60G
EMGA-60-P-G3-SAS-70	EMMS-AS-70-...	560283	EAMM-A-D60-60G

Note







Note the maximum permissible driving torque of the EHMB. The motor current may need to be limited.



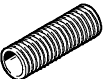

The following tool is available for sizing:

PositioningDrives sizing software → www.festo.com

3

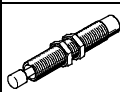
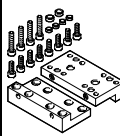
Accessories – Ordering data

	For size	Part No.	Type
1 Inductive proximity sensor, N/O contact, M8 Technical data → 755			
	PNP, cable	★ 150386	SIEN-M8B-PS-K-L
	PNP, plug	★ 150387	SIEN-M8B-PS-S-L
N/C contact, M8 Technical data → 755			
	PNP, cable	150390	SIEN-M8B-PO-K-L
	PNP, plug	150391	SIEN-M8B-PO-S-L
4 Protective conduit fitting¹⁾			
	20	1157774	EASA-H1-20-PG16
	25, 32	1096549	EASA-H1-22-PG21
5 Protective conduit			
	20	177566	MKR-16,5-PG-16
	25, 32	177567	MKR-23-PG-21
6 Cover¹⁾			
	20	1099901	EASC-H1-20-100
		1099902	EASC-H1-20-200
	25	1096387	EASC-H1-25-100
		1096388	EASC-H1-25-200
	32	1107235	EASC-H1-32-100
		1107236	EASC-H1-32-200
8 Rod eye Technical data online: → sgs			
	20	★ 9261	SGS-M10x1,25
	25, 32	★ 9262	SGS-M12x1,25
9 Shock absorber retainer¹⁾			
	20	1153896	EAYH-H1-20
	25, 32	1153905	EAYH-H1-25

	For size	Part No.	Type
10 Shock absorber¹⁾ Technical data online: → dysw			
	20	548073	DYSW-8-14-Y1F
	25, 32	548074	DYSW-10-17-Y1F
17 Adapter plate kit¹⁾			
	20	1132369	EHAM-H1-20-L2-80
	25	1132402	EHAM-H1-25-L2-80
	32	1132529	EHAM-H1-32-L2-120
Connecting cable, straight socket Technical data → 949			
	2.5 m	★ 541333	NEBU-M8G3-K-2.5-LE3
	5 m	★ 541334	NEBU-M8G3-K-5-LE3
Centring sleeve²⁾ Technical data online: → zbh			
	– ³⁾	186717	ZBH-7
		150927	ZBH-9
		189653	ZBH-12
Cam⁴⁾			
	20	1234887	EAPS-H1-20-CK
	25, 32	1234888	EAPS-H1-25-CK

- 1) Packaging unit 1 piece.
- 2) Packaging unit 10 pieces.
- 3) → Dimensional drawing 406
- 4) 2 included in the scope of delivery of the rotary/lifting module EHMB.

Note

The bracket for the proximity sensor SIEN of the rotary/lifting module. is included in the scope of delivery

3

Dimensions

Download CAD data → www.festo.com

Size	B1 ±0.5	B2 ±0.2	B3 ¹⁾	B4 ¹⁾	B5 ±0.15	B6 ±0.15	B7 ¹⁾	B8 ±0.15	D1 ∅ g7	D2 ∅ h6	D3 ∅	D4 ∅ ±0.05
20	110	65	54	34	32	32.5	30	52	32	6	58	45
25	130	85	53.5	30	42	38	60	64	40	8	80	64
32	169.5	115	70	40	62	56.5	80	88	60	12	80	64

Size	D5	D6 ∅	D7 ∅ H8	D8 ∅ H7	D9	D10 ∅ H7	D11	D12	D13	D14 ∅ H7	D15	D16 ∅ H7
20	Pg16	14	30	9	M5	7	M4	M3	M6	9	M6	4
25	Pg21	21	30	9	M5	7	M4	M4	M6	12	M8	4
32	Pg21	21	35	9	M5	–	M5	M5	M8	12	M8	4

Size	D17	D18 ∅	D19 ∅	D20	D21 ∅	D22 ∅	D23 ∅	H1 ±0.5	H2 ±0.05	H3	H4	H5 ±0.15
20	M5	–	–	M8x1	6.6	11	19 ^{H8}	149	72	45	9.5	32.5
25	M6	5.5	10	M8x1	6.6	11	30 ^{H7}	185	96	52	9.5	38
32	M6	6.2	10	M8x1	6.6	11	30 ^{H7}	229.5	108	70.5	13	56.5

Size	H6 ±0.15	H7 ±0.15	H8	L1	L2 min.	L3 ±0.1	L4 ±0.1	L5 ¹⁾	L6 ¹⁾	L7	L8	L9	L10	L11 ±0.1
20	19	44	32.5	147.5	40.5	52	40	30	30	15.8	5	7.8	9	15
25	20	64	32.5	173	58.6	46	46	30	31.5	18.35	7	–	14	15
32	31	88	38	183	61.4	60	60	40	47	23.3	6	–	14	15

Size	L12	T1	T2 +0.1	T3	T4	T5 +0.2	T6	T7 +0.1	T8	T9	T10 ±0.2	T11	T12 ±0.5	W1
20	12	14	2.1	10	9	1.6	9.5	2.1	6	8.5	–	11	3	45°
25	12	15	2.1	10	9.6	1.6	9.5	2.7	6	10	40.8	8	4	45°
32	12	15	2.1	10	9	–	9.5	2.7	6	10	54.3	15	4	45°

1) Tolerance for centring hole ±0.02 mm.
Tolerance for thread ±0.1 mm.

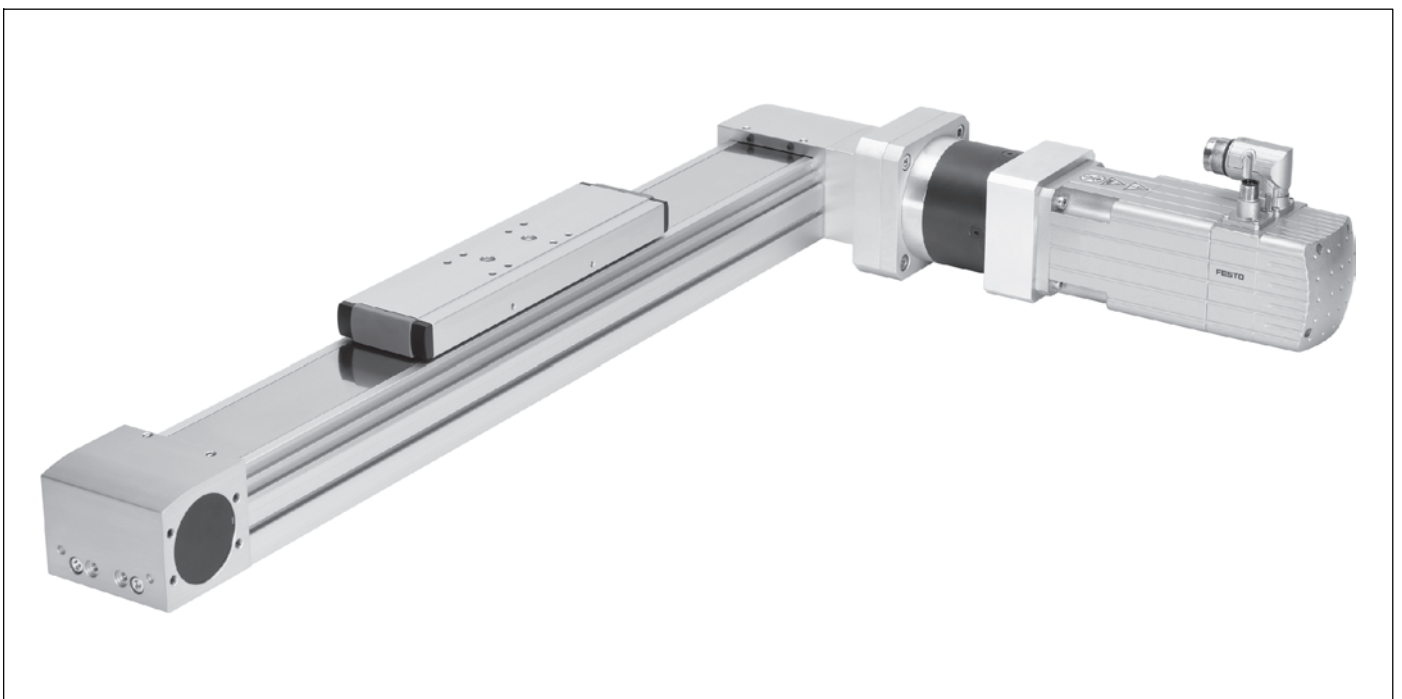

4 Motors and controllers



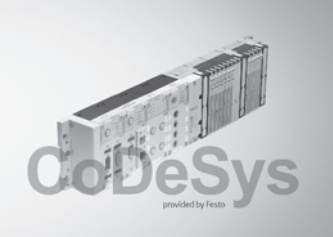

Software tool

Festo Configuration Tool (FCT)		<p>FCT is a configuration and parameterisation software program that supports all Festo devices, in particular motor controllers.</p> <p>It is extremely flexible, provides full support for the device properties and is simple and intuitive to operate. The user is guided step-by-step through the commissioning process while each individual step is checked.</p>	<p>The FCT parameterisation software can be found on the website under Support in the Support and Downloads area. Enter FCT as a search term to retrieve it.</p>
CoDeSys		<p>CoDeSys for standardised programming of embedded devices to IEC 61131-3. It makes your life easier with simple commissioning, fast programming and parameterisation.</p> <p>Advantages</p> <ul style="list-style-type: none"> • Hardware-neutral software platform for quick and easy configuration, programming and commissioning of pneumatic and electrical automation solutions • Extensive module libraries for single or multi-axis positioning motions 	<ul style="list-style-type: none"> • The IEC 61131-3 standard means that CoDeSys is flexible and open for all types of control tasks • Modular: offline and online functions as well as components for hardware configuration and visualisation • User-friendly IEC function block extension • Re-use of existing application parts <p>The CoDeSys parameterisation software can be found on the website under Support > Support Portal > enter search term.</p>



Servo motors

Type	 <p>Servo motor EMME-AS</p>	 <p>Servo motor EMMS-AS</p>	 <p>Motor unit MTR-DCI</p>
Nominal torque	0.12 ... 6.4 Nm	0.14 ... 22.63 Nm	
Nominal rotational speed	3,000 ... 9,000 rpm	2,000 ... 10,300 rpm	3,000 ... 3,400 rpm
Peak torque	0.7 ... 30 Nm	0.5 ... 120 Nm	
Max. rotational speed	3,910 ... 10,000 rpm	2,210 ... 23,040 rpm	3,000 ... 3,400 rpm
Description	<ul style="list-style-type: none"> • Brushless, permanently excited synchronous servo motor • Reliable, dynamic, precise • Choice of feedback systems: digital absolute displacement encoder in single-turn or multi-turn version • Optimised connection technology 	<ul style="list-style-type: none"> • Permanently excited, electrodynamic, brushless servo motor • Digital absolute displacement encoder in single-turn or multi-turn version • Optionally with holding brake • Optimised connection technology 	<ul style="list-style-type: none"> • DC motor with encoder • Gear unit, controller, power electronics integrated • RS232 parameterisation interface • I/O, PROFIBUS, CANopen, PROFIBUS DP, DeviceNet interface • Control panel with display, optional • Gear ratio: 7:1, 14:1, 22:1
→ Page/online	emme	415	434



Stepper motors

Type	 <p>Stepper motor EMMS-ST</p>	 <p>Stepper motor MTR-ST</p>
Max. rotational speed	430 ... 2,720 rpm	
Motor holding torque	0.5 ... 9.3 Nm	0.34 Nm
Description	<ul style="list-style-type: none"> • 2-phase hybrid technology • Stepper angle 1.8° • Standard industrial connection technology • Optional: encoder, brake 	<ul style="list-style-type: none"> • With integrated controller • Optional: brake • Step-accurate positioning through specification of the number of control pulses • Stepper angle (full step) 1.8°
→ Page/online	439	mitre



Controllers for AC servo motors

Type	 Motor controller CMMD-AS	 Motor controller CMMS-AS	 Motor controller CMMP-AS, CMMP-AS-M3
Nominal current	8 ... 10 A	4 ... 5 A	2 ... 20 A
Nominal operating voltage AC	230 V	230 V	230 ... 400 V
Nominal operating voltage phases	1-phase	1-phase	1-phase, 3-phase
Rated output of controller	1,200 VA	600 VA	500 ... 12,000 VA
Fieldbus coupling	CANopen, DeviceNet, PROFIBUS DP	CANopen, DeviceNet, PROFIBUS DP	CANopen, DeviceNet, Ethernet, EtherNet/IP, PROFIBUS DP, PROFINET, Sercos
Description	<ul style="list-style-type: none"> • Only one piece of controller hardware required to move two servo motors independently of each other • The motor current of 2x 4 A can be distributed between both controllers with a ratio of 2 A:6 A • Easy and user-friendly: commissioning and firmware updates via SD card slot • Programming and parameterisation via software tools • Jerk-free and infinite positioning by means of closed-loop operation • Reliable restart blocking for safety-relevant applications 	<ul style="list-style-type: none"> • Digital absolute angle encoder in single-turn and multi-turn versions • Can be operated as a torque, speed or position controller • Position controller, integrated brake chopper • I/O coupling • Electronic gear unit 	<ul style="list-style-type: none"> • Flying saw • For cam disk controllers and highly dynamic movements • Standardised interfaces allow seamless integration in mechatronic multi-axis modular systems • Reliable and convenient commissioning, programming and parameterisation via software tools • Optionally with 3 slots for switch or safety module, for extension module
→ Page/online	446	450	454

Controllers for DC servo motors

Type	 Motor controller SFC-LACI	 Motor controller SFC-DC	 End-position controller CMFL
Nominal current, load supply	100	30	30
Nominal voltage, load supply DC	48 V	24 V	24 V or 48 V
Rated output of controller	480 VA	75 VA	
Fieldbus coupling	CANopen, PROFIBUS DP	CANopen, DeviceNet, PROFIBUS DP	
Description	<ul style="list-style-type: none"> • High degree of protection IP54 • Open-loop and closed-loop position controller • Easy actuation via I/O interface, PROFIBUS, CANopen including interpolated position mode • With or without control panel • Parameterisation via control panel or parameterisation software FCT • For actuating electric cylinders • DNCE-LAS and guided drive DFME-LAS 	<ul style="list-style-type: none"> • High degree of protection IP54 • Easy actuation via I/O interface, PROFIBUS, CANopen, DeviceNet • With or without control panel • Parameterisation via control panel or parameterisation software FCT • For actuating mini slide SLTE, parallel gripper HGPLE 	<ul style="list-style-type: none"> • For force-controlled positioning of short-stroke cylinder ADNE-LAS • Realisation of dynamic movement with continuous monitoring, including "Motion Complete" • High dynamic response
→ Page/online	sfc-laci	sfc-dc	cmfl





Controllers for stepper motors

Type	 Motor controller CMMO-ST	 Motor controller CMMS-ST	 Motor controller SEC-ST
Nominal current	5 A		1.25 ... 6 A
Nominal current, load supply	6 A	8 A	
Max. step frequency		4 kHz	40 kHz
Controller operating mode	Cascade controller with PI speed controller, PI current controller, P position controller, PWM MOSFET power end stage	PWM MOSFET power end stage	Bipolar chopper driver
Fieldbus coupling		CANopen, PROFIBUS DP	
Description	<ul style="list-style-type: none"> As open-loop and closed-loop position controller Separate load and logic supply Supports the "Safe Torque Off" (STO) safety function Easy actuation via I/O interface Monitoring of freely definable position zones Backup file enables seamless device replacement 	<ul style="list-style-type: none"> Can be operated as a torque, speed or position controller Position controller, integrated brake chopper I/O coupling Electronic gear unit 	<ul style="list-style-type: none"> Compact unit, ready for installation Current reduction Pre-assembled, electrical connection accessories
→ Page/online	460	463	sec-st



Safety systems

Type	 Safety system CMGA-B1, CMGA-E1
Safety function	Encoder Supervisor (ECS), Safe Torque Off (STO), Safely Limited Acceleration (SLA), Safely Limited Speed (SLS), Safely Limited Position (SLP), Safely Limited Increment (SLI), Safe Emergency Limit (SEL), Safe Direction (SDI), Safe Brake Control (SBC), Safe Acceleration Range (SAR), Safe Operating Stop (SOS), Safe Cam (SCA), Safe Stop 1 (SS1), Safe Stop 2 (SS2), Position Deviation Muting (PDM), safe encoder evaluation, safe logic functions
Safety integrity level (SIL)	SIL 3
Encoder interface Input, function	1 proximity sensor, 1 SSI, 1 incr.-HTL, 1 incr.-TTL, 1 sin/cos, 2 proximity sensors, 2 SSI, 2 incr.-HTL, 2 incr.-TTL, 2 sin/cos, no
Number of digital logic inputs	12 ... 14
Digital output version	1 safe relay output, 10 safe digital inputs/outputs, 2 signal outputs, 2 pulse outputs, 2 safe digital outputs
Description	<ul style="list-style-type: none"> Basic modules CMGA-B1 and extension modules CMGA-E1: one basic module can actuate max. two extension modules Compact safety system with the option of integrated drive monitoring for one axis For safe processing of emergency stop switches, door monitoring, light curtains, two-hand buttons, enabling buttons, limit switches, displacement encoders Programming software GSPF for creating custom application programs
→ Page/online	467

Multi-axis controllers

Type	 Control block CPX-CMXX	 Control block CPX-CEC-M1	 Controller CECX-X-M1	 Controller CECX-X-C1
Operating voltage		512	19.2 ... 30 V DC	19.2 ... 30 V DC
Operating voltage range DC	18 ... 30 V	512		
Control interface	CAN Bus	1	CAN Bus	CAN Bus
Fieldbus coupling		CoDeSys Level 2, EasyIP, Modbus TCP, TCP/IP	TCP/IP, EasyIP, Modbus TCP	TCP/IP, EasyIP, Modbus TCP
Supported kinematic systems	2-axis gantries X-Z/Y-Z/X-Y, 3-axis gantries X-Y-Z			
Description	<ul style="list-style-type: none"> Intelligent module in the CPX terminal for actuating electric drive units Coordination of the entire motion sequence Actuation of 2 axis groups with max. 4 axes per group Ethernet, CAN Bus interface 	<ul style="list-style-type: none"> Programming with CoDeSys to IEC 61131-3 Easy actuation of valve terminal configurations with MPA, VTSA Connection to all fieldbuses as remote controller and for pre-processing Diagnostics with flexible monitoring options for pressure, flow rate, cylinder operating time, air consumption Actuation of electric drives as individual axes via CANopen SoftMotion functions for coordinated multi-axis movements Fieldbus interface: CAN Bus 	<ul style="list-style-type: none"> Motion controller with CoDeSys and SoftMotion Programming to standard IEC 61131-3 Three plug-in slots for optional modules Optional: communication module for PROFIBUS 	<ul style="list-style-type: none"> Modular master controller with CoDeSys Programming to standard IEC 61131-3 Three plug-in slots for optional modules Optional: communication module for PROFIBUS
→ Page/online	cmxx	cpx-cec-m1	cecx	cecx



Multi-axis controllers

Type	 Controller CMXR-C1	 Controller CMXR-C2
Operating voltage	24 V DC +20%/-15%, 24 V DC +25%/-20%	24 V DC +20%/-15%, 24 V DC +25%/-20%
Operating voltage range DC		
Control interface		
Fieldbus coupling	2 x CANopen masters	2 x CANopen masters
Supported kinematic systems	2-axis gantries X-Z/Y-Z/X-Y, 3-axis gantries X-Y-Z, any interpolation, tripod	2-axis gantries X-Z/Y-Z/X-Y, 3-axis gantries X-Y-Z, any interpolation, tripod
Description	<ul style="list-style-type: none"> Multi-axis control for linear and three-dimensional gantries, tripods Optional teach pendant CDSA Point-to-point and complex path control Ethernet, CAN Bus interface 	<ul style="list-style-type: none"> Individual integration in higher-order controller hierarchies or simple integration of peripheral devices, e.g. tracking function via vision system by means of integrated CoDeSys PLC Ideal for bonding or sealing applications: greater process reliability and quality with defined, speed-independent switching points on the path Increased flexibility: modular control system for digital and analogue I/O optionally expandable
→ Page/online	cmxr-c1	cmxr-c2



Control systems

	
Type	Control system CMCA
Electrical connection	Spring-loaded terminal
Mains voltage AC	230/400 V
Nominal operating voltage phases	3-phase
Mains frequency	50 ... 60 Hz
Safety function	Safe Stop 1 (SS1)
Description	<ul style="list-style-type: none"> Control solution for handling systems from Festo Available as a mounting plate with or without control cabinet housing Includes the multi-axis controller CMXR and the motor controller CMMP required for actuation
→ Page/online	cmca

Gear units

		
Type	Gear unit EMGA-SST	Gear unit EMGA-SAS
Continuous output torque	11 ... 110 Nm	11 ... 450 Nm
Max. drive speed	6,500 ... 18,000 rpm	6,500 ... 18,000 rpm
Torsional rigidity	1 ... 6 Nm/arc	1 ... 38 Nm/arc
Torsional backlash	0.12 ... 0.25°	0.1 ... 0.25°
Mass moment of inertia of gear unit	0.019 ... 0.77 kgcm ²	0.019 ... 12.14 kgcm ²
Max. efficiency	98%	98%
Description	<ul style="list-style-type: none"> Planetary gear unit for stepper motors EMMS-ST Gear reduction $i = 3$ and 5, available ex-stock Life-time lubrication 	<ul style="list-style-type: none"> Planetary gear unit for servo motors EMMS-AS Gear reduction $i = 3$ and 5, available ex-stock Life-time lubrication
→ Page/online	473	475

Power supply units

		
Type	Power supply unit CACN	Power supply unit SVG
Nominal output voltage DC	24 ... 48 V	24 ... 48 V
Nominal output current	5 ... 20 A	4.8 ... 20 A
Input voltage range AC	100 ... 500 V	100 ... 500 V
Input current	0.9 ... 1.65 A, 1.5 ... 3.0 A, 2.2 ... 1.2 A, 2.3 ... 1.9 A, 5.1 ... 2.3 A	1.9 0.8 A, 2.1 1.0 A, 2.2 1.2 A, 2.3 1.9 A, 2.8 1.2 A, 5.1 2.3 A
Power failure buffering	24 ... 110 ms	20 ... 50 ms
Description	<ul style="list-style-type: none"> H-rail mounting Mounting position: free convection 	<ul style="list-style-type: none"> H-rail mounting Mounting position: free convection
→ Page/online	cacn	svg



- Suitable for motor controller CMMS-AS and CMMP-AS
- Digital absolute displacement encoder with single turn (standard), multi-turn (optional)
- No homing after voltage failure
- Matching gear unit
- ★ Quick ordering of basic designs → 428

→ www.festo.com/catalogue/emms-as

Product range overview

Motor flange size	Nominal voltage [V AC]	Nominal torque [Nm]	With gear unit	With brake
40	360	0.14 ... 0.22	■	■
55	360, 565	0.31 ... 0.68	■	■
70	360, 565	1.37 ... 2.29	■	■
100	565	3.24 ... 7.51	■	■
140	565	9.55 ... 21.12	■	■
190	565	17.47 ... 22.63	■	■

Product options

S	Short	LS	Low-voltage, standard	A	Angled plug	S	Absolute encoder, single turn
M	Medium	LV	Low-voltage, speed-optimised	R	Angled plug, rotatable	M	Absolute encoder, multi-turn
L	Long	HS	High-voltage, standard	S	Straight plug	R	Resolver
K	Shaft to DIN 6885 with feather key	HV	High-voltage, speed-optimised	T	Terminal box	B	Brake
						S1	IP65 (with rotary shaft seal)

At a glance

Performance characteristics of the motors in combination with controllers

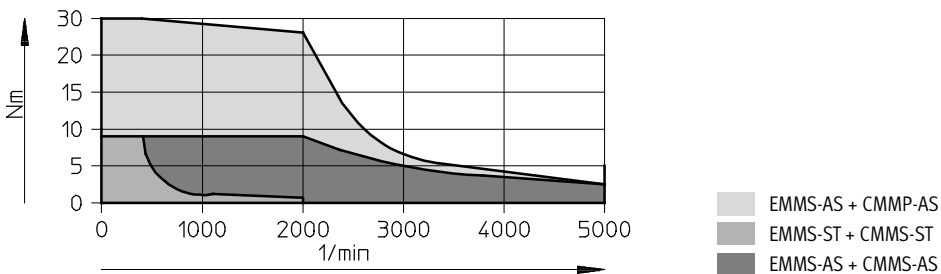

Technical data

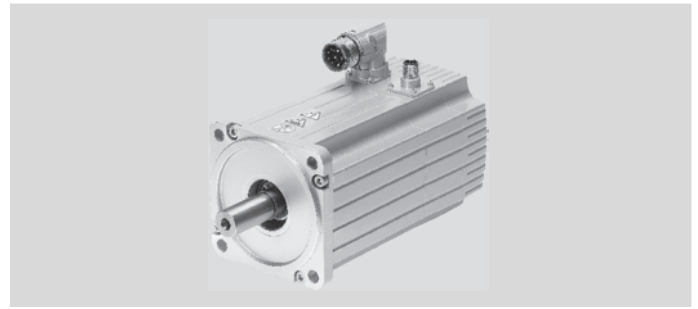

4

Technical data		Dimensions → 430									
Motor flange size		40		55				70			
Length		S	M	S	S	M	M	S	S	S	S
Winding		LS	LS	LS	HS	LS	HS	LS	LV	HS	HV
Nominal voltage	[V AC]	360	360	360	565	360	565	360	360	565	565
Nominal current	[A]	0.83	0.63	0.83	0.49	1.19	0.80	2.20	2.64	1.29	1.60
Peak current	[A]	3.3	3.3	4.30	2.70	5	4.90	5	11	5.90	7.50
Rated output	[W]	135	232	261	246	461	470	866	945	794	992
Nominal torque	[Nm]	0.14	0.22	0.34	0.31	0.67	0.68	1.43	1.37	1.31	1.28
Peak torque	[Nm]	0.5	1	1.65	1.62	2.7	3.8	3.10	5	5.17	5.17
Torque at standstill	[Nm]	0.16	0.26	0.49	0.46	0.97	0.99	1.64	1.64	1.50	1.62
Nominal rotational speed	[rpm]	9,000	10,300	7,400	7,600	6,600	6,600	5,300	6,600	5,800	7,400
Max. rotational speed	[rpm]	23,040	11,520	9,800	9,840	7,330	7,750	6,450	8,070	6,460	8,200
Brake											
Operating voltage	[V DC]	24 +6 ... -10%									
Holding torque	[Nm]	0.4		0.8				2			

Flange size		70				100			
Length		M	M	M	M	S	M	L	L
Winding		LS	LV	HS	HV	HS	HS	HS	HV
Nominal voltage	[V AC]	360	360	565	565	565	565	565	565
Nominal current	[A]	2.60	3.02	1.70	1.84	3.30	3.40	3.80	3.79
Peak current	[A]	10	12.50	7.40	8.30	15	15	24.80	24.80
Rated output	[W]	1,061	1,100	1,044	1,146	1,560	2,000	2,360	2,240
Nominal torque	[Nm]	2.29	2.28	2.26	2.19	3.24	5.63	7.51	6.29
Peak torque	[Nm]	7.75	8.30	8.55	8.55	12.50	22.10	39.80	35.40
Torque at standstill	[Nm]	2.56	2.57	2.53	2.52	4.71	8.01	10.94	10.93
Nominal rotational speed	[rpm]	4,100	4,600	4,400	5,000	4,600	3,400	3,000	3,400
Max. rotational speed	[rpm]	4,880	5,570	4,960	5,560	6,680	4,030	3,360	4,040
Brake									
Operating voltage	[V DC]	24 +6 ... -10%							
Holding torque	[Nm]	2				9			

Flange size		140				190	
Length		S	S	L	L	S	M
Winding		HS	HV	HS	HV	HS	HS
Nominal voltage	[V AC]	565	565	565	565	565	565
Nominal current	[A]	4.40	5.23	7.80	9.96	14.43	14.24
Peak current	[A]	15	24.40	20	51.50	77.20	88.20
Rated output	[W]	2,600	3,140	4,420	5,110	5,490	6,880
Nominal torque	[Nm]	9.55	7.70	21.12	17.41	17.47	22.63
Peak torque	[Nm]	25.60	27	48.80	67.50	80	120
Torque at standstill	[Nm]	11.20	11.08	25.60	25.50	26.20	38.77
Nominal rotational speed	[rpm]	2,600	3,900	2,000	2,800	3,000	2,900
Max. rotational speed	[rpm]	3,060	4,510	2,460	3,830	5,300	4,060
Brake							
Operating voltage	[V DC]	24 +6 ... -10%					
Holding torque	[Nm]	18				30	

Technical data

Technical data – Encoder		
Type	EMMS-AS-...-...S...	EMMS-AS-...-...M...
	Absolute, single turn	Absolute, multi-turn
Operating voltage [V DC]	5	
Protocol	EnDat 2.1, digital channel only, max. cycle rate (CLOCK) 2 MHz	
Position values per revolution	262,144	
Version	Standard	Optional
Resolution	18 bits	
	-	- 4,096 revolutions, 12 bits

Technical data – Resolver		
Version	Transmitter	
Input voltage [V DC]	4	
Input current [mA]	50	
Number of poles	2	
Carrier frequency [kHz]	3.4 ... 8.0	

Operating conditions		
	Encoder	Resolver
Ambient temperature [°C]	-10 ... +40 (up to 100 °C with derating)	-40 ... +40 (up to 130 °C with derating)
Protection class		
Motor shaft	IP54	
Motor housing incl. connection technology	IP65	
With rotary shaft seal	IP65	
Insulation protection class	F	
Rated class to EN 60034-1	S1	
Thermal class to EN 60034-1	F	

Technical data

Torque M as a function of rotational speed n

Flange size 40

Length S

Winding LS

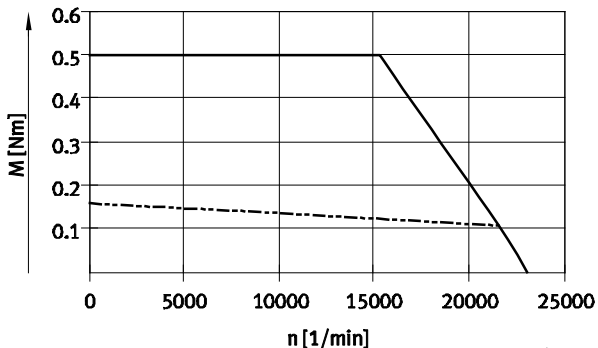

Length M

Winding LS

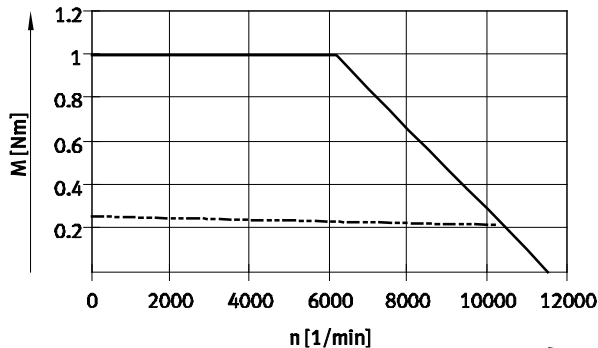

Flange size 55

Length S

Winding LS

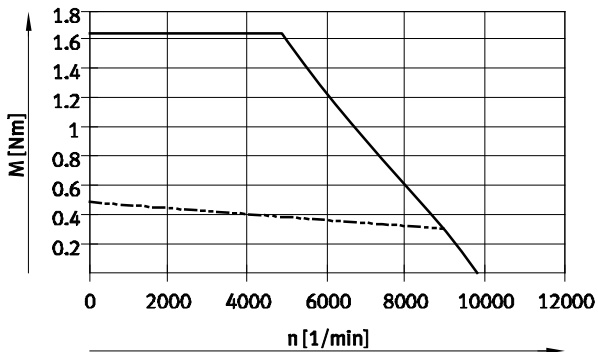

Length S

Winding HS

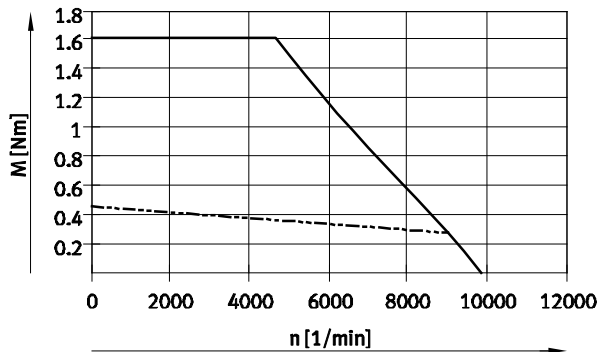

Length M

Winding LS

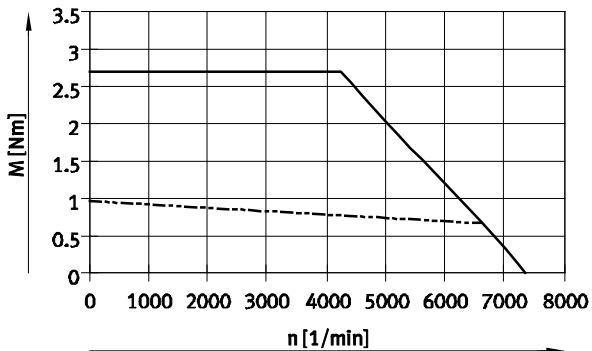

Length M

Winding HS

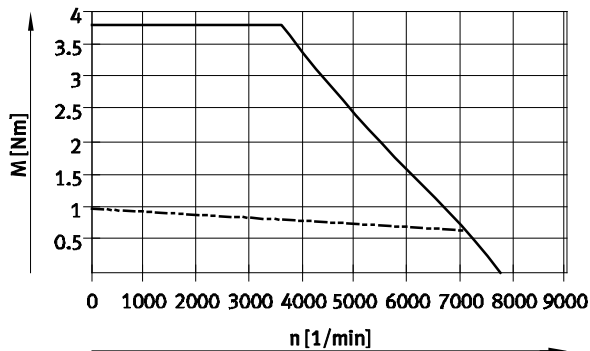

— Peak torque
 - - - Nominal torque

Note

Typical motor characteristic curve with nominal voltage and optimal motor controller.

4

Technical data

Torque M as a function of rotational speed n

Flange size 70

Length S

Winding LS, LV

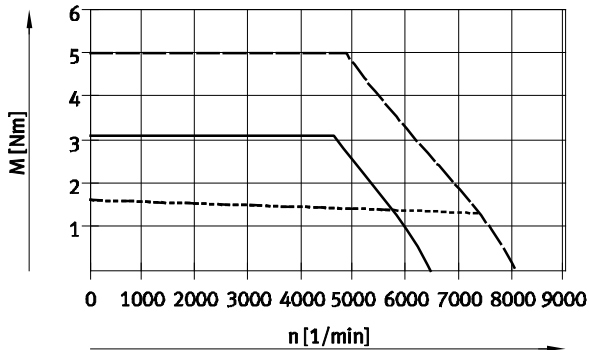

- Peak torque EMMS-AS-...-LS
- - - Nominal torque EMMS-AS-...-LS
- Peak torque EMMS-AS-...-LV
- - - Nominal torque EMMS-AS-...-LV

Length S

Winding HS, HV

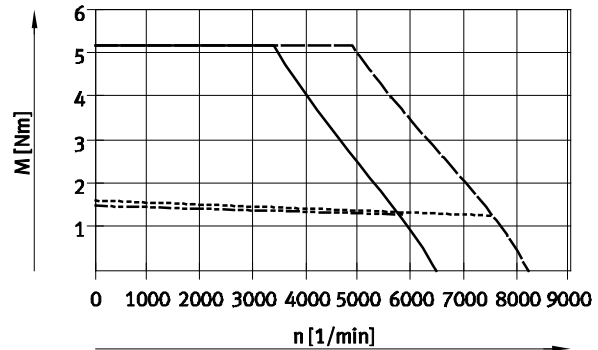

- Peak torque EMMS-AS-...-HS
- - - Nominal torque EMMS-AS-...-HS
- Peak torque EMMS-AS-...-HV
- - - Nominal torque EMMS-AS-...-HV

Length M

Winding LS, LV

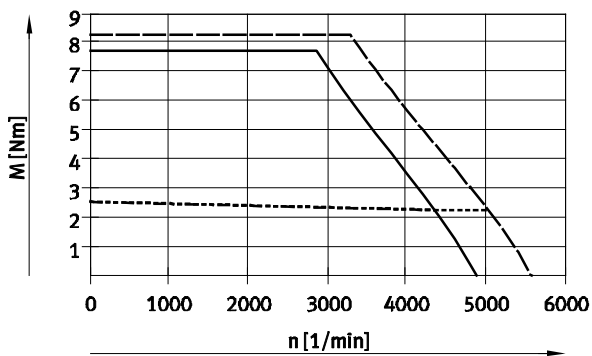

- Peak torque EMMS-AS-...-LS
- - - Nominal torque EMMS-AS-...-LS
- Peak torque EMMS-AS-...-LV
- - - Nominal torque EMMS-AS-...-LV

Length M

Winding HS, HV

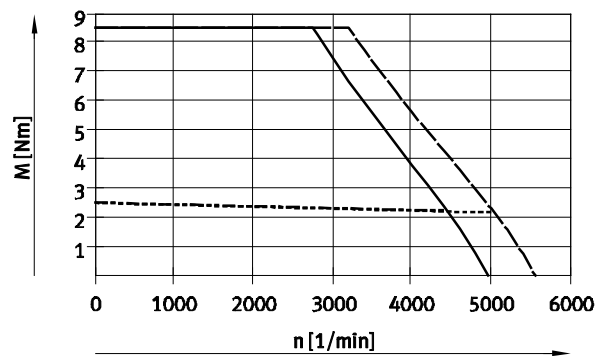

- Peak torque EMMS-AS-...-HS
- - - Nominal torque EMMS-AS-...-HS
- Peak torque EMMS-AS-...-HV
- - - Nominal torque EMMS-AS-...-HV

Note

Typical motor characteristic curve with nominal voltage and optimal motor controller.

Technical data

Torque M as a function of rotational speed n

Flange size 100

Length S

Winding HS

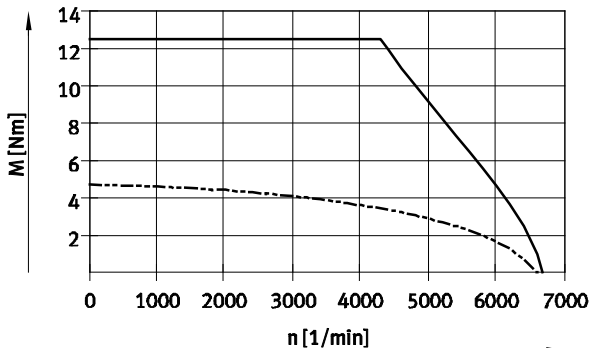

Length M

Winding HS

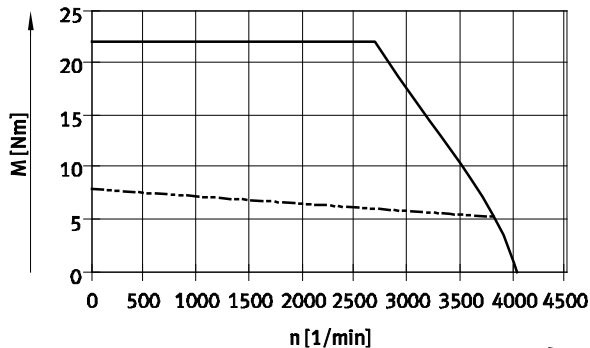

Length L

Winding HS

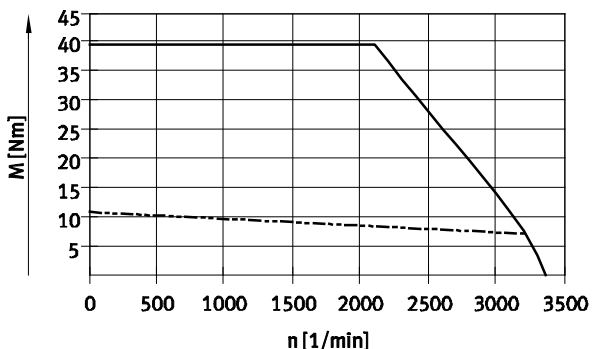

Length L

Winding HV

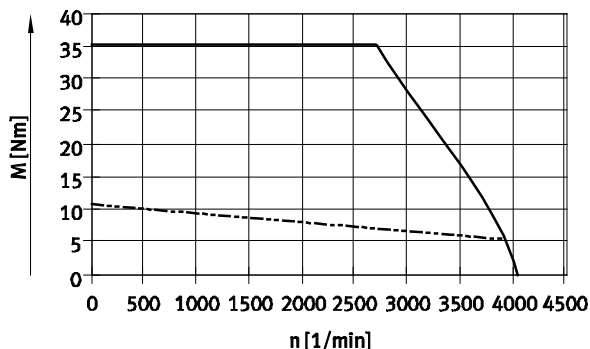

Flange size 140

Length S

Winding HS

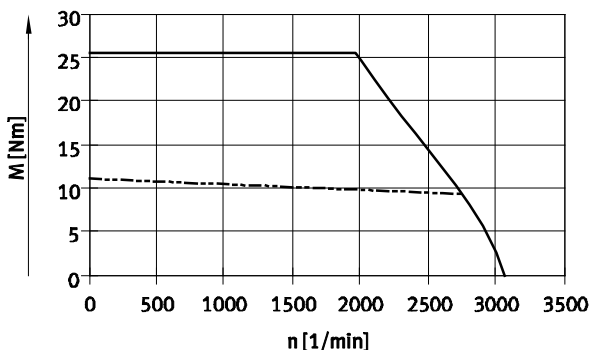

Length S

Winding HV

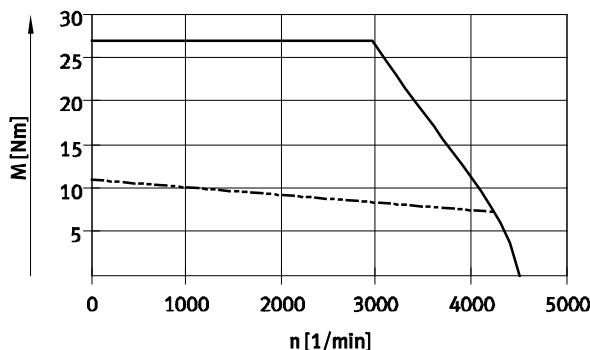

— Peak torque
 - - - - - Nominal torque

Note

Typical motor characteristic curve with nominal voltage and optimal motor controller.

4

Technical data

Torque M as a function of rotational speed n

Flange size 140

Length L

Winding HS

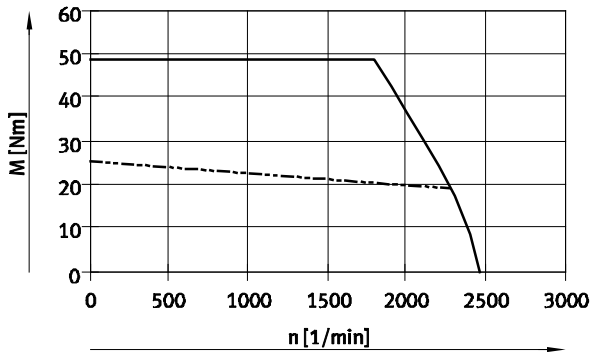

Length L

Winding HV

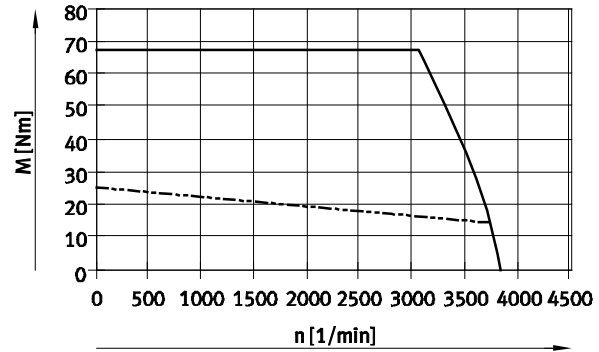

Flange size 190

Length S

Winding HS

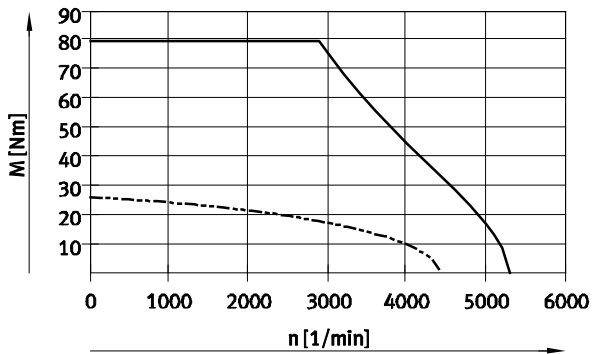

Length M

Winding HS

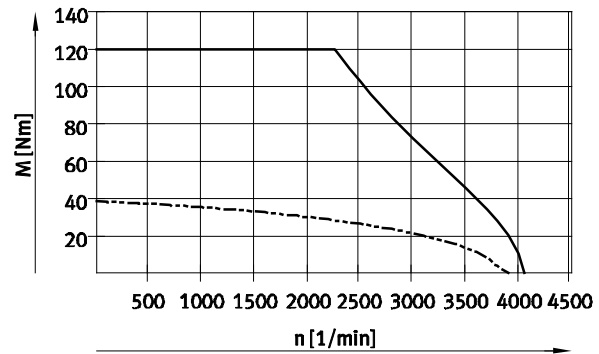

— Peak torque
 - - - Nominal torque

Note

Typical motor characteristic curve with nominal voltage and optimal motor controller.

4

Order code – Size 40

		EMMS	–	AS	–	40	–		–	LS	–	
Type												
EMMS	Motor											
Motor type												
AS	Servo motor											
Motor flange size												
40	40 mm											
Length												
S	Short											
M	Medium											
Output shaft												
–	Smooth shaft											
K	Shaft to DIN 6885 (with feather key)											
Winding												
LS	Low-voltage, standard											
Electrical connection												
S	Straight plug											
T	Terminal box											
Measuring unit												
S	Absolute encoder, single turn		<input type="checkbox"/>	<input type="checkbox"/>	<input type="checkbox"/>	<input type="checkbox"/>	<input type="checkbox"/>	<input type="checkbox"/>	<input type="checkbox"/>	<input type="checkbox"/>	<input type="checkbox"/>	<input type="checkbox"/>
M	Absolute encoder, multi-turn		<input type="checkbox"/>	<input type="checkbox"/>	<input type="checkbox"/>	<input type="checkbox"/>	<input type="checkbox"/>	<input type="checkbox"/>	<input type="checkbox"/>	<input type="checkbox"/>	<input type="checkbox"/>	<input type="checkbox"/>
R	Resolver		<input type="checkbox"/>	<input type="checkbox"/>	<input type="checkbox"/>	<input type="checkbox"/>	<input type="checkbox"/>	<input type="checkbox"/>	<input type="checkbox"/>	<input type="checkbox"/>	<input type="checkbox"/>	<input type="checkbox"/>
Brake												
–	None											
B	With brake											

Only with electrical connection T.

Only with electrical connection S.

Order code – Size 55

EMMS – AS – 55 – [] – [] – [] – []

Type

EMMS	Motor
------	-------

Motor type

AS	Servo motor
----	-------------

Motor flange size

55	55 mm
----	-------

Length

S	Short
M	Medium

Output shaft

–	Smooth shaft
K	Shaft to DIN 6885 (with feather key)

Winding

LS	Low-voltage, standard
HS	High-voltage, standard

Electrical connection

R	Angled plug, rotatable
T	Terminal box

Measuring unit

S	Absolute encoder, single turn	[1]
M	Absolute encoder, multi-turn	[1]
R	Resolver	[2]

Brake

–	None
B	With brake

Protection class

–	Standard
S1	IP65 (with rotary shaft seal)

[1] Only with electrical connection T. [2] Only with electrical connection R.

Order code – Size 70

		EMMS	–	AS	–	70	–		–		–		–	
Type														
EMMS	Motor													
Motor type														
AS	Servo motor													
Motor flange size														
70	70 mm													
Length														
S	Short													
M	Medium													
Output shaft														
–	Smooth shaft													
K	Shaft to DIN 6885 (with feather key)													
Winding														
LS	Low-voltage, standard													
LV	Low-voltage, speed-optimised													
HS	High-voltage, standard													
HV	High-voltage, speed-optimised													
Electrical connection														
R	Angled plug, rotatable													
Measuring unit														
S	Absolute encoder, single turn													
M	Absolute encoder, multi-turn													
R	Resolver													
Brake														
–	None													
B	With brake													
Protection class														
–	Standard													
S1	IP65 (with rotary shaft seal)													

Order code – Size 100

		EMMS	–	AS	–	100	–		–		–		–	
Type														
EMMS	Motor													
Motor type														
AS	Servo motor													
Motor flange size														
100	100 mm													
Length														
S	Short													
M	Medium													
L	Long													
Output shaft														
–	Smooth shaft													
K	Shaft to DIN 6885 (with feather key)													
Winding														
HS	High-voltage, standard													
HV	High-voltage, speed-optimised ¹													
Electrical connection														
R	Angled plug, rotatable													
Measuring unit														
S	Absolute encoder, single turn													
M	Absolute encoder, multi-turn													
R	Resolver													
Brake														
–	None													
B	With brake													
Protection class														
–	Standard													
S1	IP65 (with rotary shaft seal)													

¹ Only with length L.

Order code – Size 140

		EMMS	–	AS	–	140	–		–		–		–	
Type														
EMMS	Motor													
Motor type														
AS	Servo motor													
Motor flange size														
140	140 mm													
Length														
S	Short													
L	Long													
Output shaft														
–	Smooth shaft													
K	Shaft to DIN 6885 (with feather key)													
Winding														
HS	High-voltage, standard													
HV	High-voltage, speed-optimised													
Electrical connection														
R	Angled plug, rotatable													
Measuring unit														
S	Absolute encoder, single turn													
M	Absolute encoder, multi-turn													
R	Resolver													
Brake														
–	None													
B	With brake													
Protection class														
–	Standard													
S1	IP65 (with rotary shaft seal)													

Order code – Size 190

		EMMS	–	AS	–	190	–		–		–		–	
Type														
EMMS	Motor													
Motor type														
AS	Servo motor													
Motor flange size														
190	190 mm													
Length														
S	Short													
M	Medium													
Output shaft														
–	Smooth shaft													
K	Shaft to DIN 6885 (with feather key)													
Winding														
HS	High-voltage, standard													
Electrical connection														
A	Angled plug													
Measuring unit														
S	Absolute encoder, single turn													
M	Absolute encoder, multi-turn													
R	Resolver													
Brake														
–	None													
B	With brake													
Protection class														
–	Standard													
S1	IP65 (with rotary shaft seal)													

4

★ Quick ordering

Part No.	Type
Flange size 40, medium length	
550106	EMMS-AS-40-M-LS-TS
550107	EMMS-AS-40-M-LS-TM
550108	EMMS-AS-40-M-LS-TSB
550109	EMMS-AS-40-M-LS-TMB
Flange size 55, medium length	
550110	EMMS-AS-55-M-LS-TS
550111	EMMS-AS-55-M-LS-TM
550112	EMMS-AS-55-M-LS-TSB
550113	EMMS-AS-55-M-LS-TMB
Flange size 70, short length	
550114	EMMS-AS-70-S-LS-RS
550115	EMMS-AS-70-S-LS-RM
550116	EMMS-AS-70-S-LS-RSB
550117	EMMS-AS-70-S-LS-RMB
Flange size 70, medium length	
550118	EMMS-AS-70-M-LS-RS
550119	EMMS-AS-70-M-LS-RM
550120	EMMS-AS-70-M-LS-RSB
550121	EMMS-AS-70-M-LS-RMB

Part No.	Type
Flange size 100, short length	
550122	EMMS-AS-100-S-HS-RS
550123	EMMS-AS-100-S-HS-RM
550124	EMMS-AS-100-S-HS-RSB
550125	EMMS-AS-100-S-HS-RMB
Flange size 100, medium length	
550127	EMMS-AS-100-M-HS-RS
550128	EMMS-AS-100-M-HS-RM
550129	EMMS-AS-100-M-HS-RSB
550130	EMMS-AS-100-M-HS-RMB

Part No.	Type
Flange size 140, short length	
550131	EMMS-AS-140-S-HS-RS
550132	EMMS-AS-140-S-HS-RM
550133	EMMS-AS-140-S-HS-RSB
550134	EMMS-AS-140-S-HS-RMB
Flange size 140, long length	
550135	EMMS-AS-140-L-HS-RS
550136	EMMS-AS-140-L-HS-RM
550137	EMMS-AS-140-L-HS-RSB
550138	EMMS-AS-140-L-HS-RMB

4

Ordering – Product options

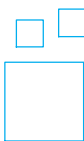

Configurable
product





This product and all its options can
be ordered using the configurator.

The configurator can be found under
Products on the DVD or
→ www.festo.com/catalogue/...

Enter the type code in the search field.

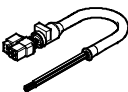
Accessories – Ordering data

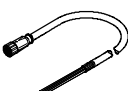
Motor cable

	Cable length		Part No.	Type
For EMMS-AS-40/55 with encoder				
	5 m	★	550306	NEBM-T1G7-E-5-N-LE7
	10 m	★	550307	NEBM-T1G7-E-10-N-LE7
	15 m	★	550308	NEBM-T1G7-E-15-N-LE7
	X length ¹⁾		550309	NEBM-T1G7-E- -N-LE7
For EMMS-AS-70 and EMMS-AS/40/55 with resolver				
	5 m		1732657	NEBM-M23G8-E-5-N-LE8
	10 m		1732658	NEBM-M23G8-E-10-N-LE8
	15 m		1732659	NEBM-M23G8-E-15-N-LE8
	X length ¹⁾		1732660	NEBM-M23G8-E- -N-LE8
For EMMS-AS-70/100/140				
	5 m	★	550310	NEBM-M23G6-E-5-N-LE7
	10 m	★	550311	NEBM-M23G6-E-10-N-LE7
	15 m	★	550312	NEBM-M23G6-E-15-N-LE7
	X length ¹⁾		550313	NEBM-M23G6-E- -N-LE7
For EMMS-AS-190				
	5 m		1750241	NEBM-M40G8-E-5-N-LE7
	10 m		1750242	NEBM-M40G8-E-10-N-LE7
	15 m		1750243	NEBM-M40G8-E-15-N-LE7
	X length ¹⁾		1750244	NEBM-M40G8-E- -N-LE7

1) Max. 25 m. Cable lengths > 25 m possible following technical clarification; up to 100 m on request.
 Available in 0.1 m increments.

Encoder cable

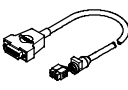
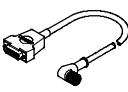
	Cable length		Part No.	Type
For EMMS-AS-40/55				
	5 m	★	550314	NEBM-T1G8-E-5-N-S1G15
	10 m	★	550315	NEBM-T1G8-E-10-N-S1G15
	15 m	★	550316	NEBM-T1G8-E-15-N-S1G15
	X length ¹⁾		550317	NEBM-T1G8-E- -N-S1G15
For EMMS-AS-70/100/140/190				
	5 m	★	550318	NEBM-M12W8-E-5-N-S1G15
	10 m	★	550319	NEBM-M12W8-E-10-N-S1G15
	15 m	★	550320	NEBM-M12W8-E-15-N-S1G15
	X length ¹⁾		550321	NEBM-M12W8-E- -N-S1G15

1) Max. 25 m. Cable lengths > 25 m possible following technical clarification; up to 100 m on request.
 Available in 0.1 m increments.

Resolver cable

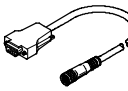
	Cable length		Part No.	Type
For EMMS-AS-40/55/70/100/140/190				
	5 m		1732653	NEBM-M23G12-E-5-N-S1G9
	10 m		1732654	NEBM-M23G12-E-10-N-S1G9
	15 m		1732655	NEBM-M23G12-E-15-N-S1G9
	X length ¹⁾		1732656	NEBM-M23G12-E- -N-S1G9

1) Max. 25 m. Cable lengths > 25 m possible following technical clarification; up to 100 m on request.
 Available in 0.1 m increments.

Dimensions

Flange size 40 – With encoder

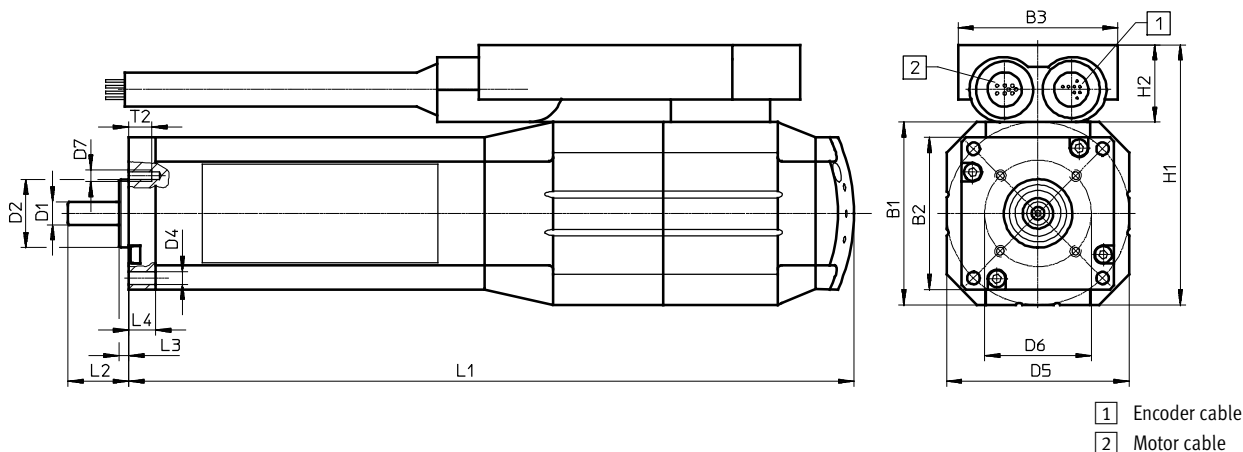

Overall length	B1	B2	B3	D1 Ø +0.009/-0.001	D2 Ø +0.012/-0.006	D4 Ø	D5 Ø	D6 Ø
S	48	40	42	6	18	3.3	48	28
M								

Overall length	D7	H1	H2	L1	L2	L3 -0.1	L4	T2
S	M3	68.3	20.3	170.5	16	2.5	7	6
M				190.5				

Flange size 40 – With resolver

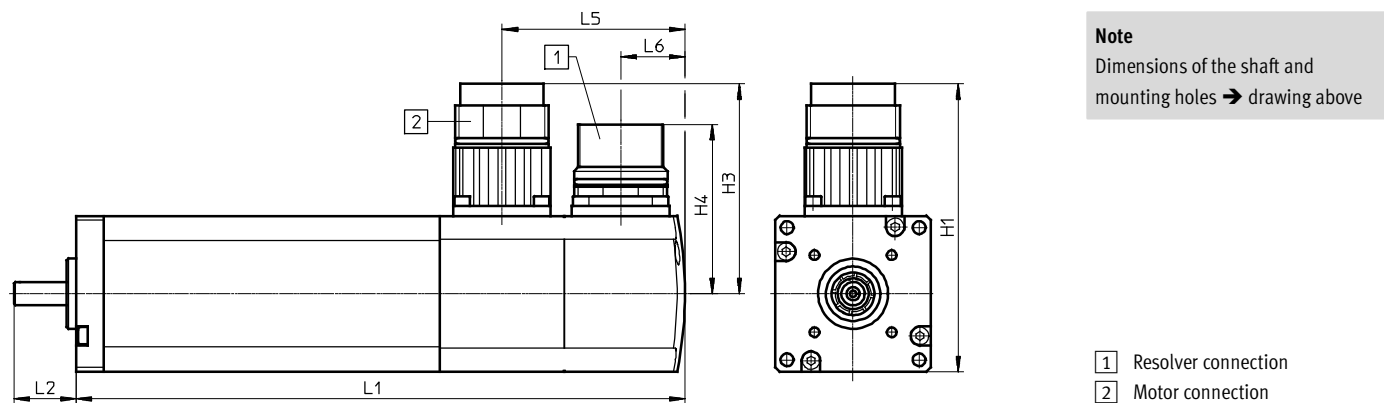

Overall length	H1	H3	H4	L1		L2	L5		L6
					With brake			With brake	
S	74	54	44	134.9	136.4	16	46.5	48	17
M				154.9	156.4				

Dimensions

Flange size 55 – With encoder

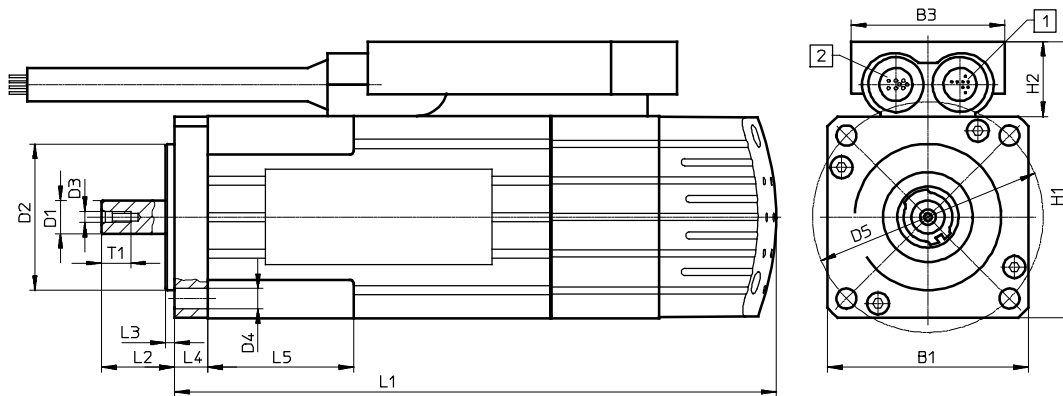

- 1 Encoder cable
- 2 Motor cable

Overall length	B1	B3	D1 ∅ +0.01/-0.001	D2 ∅ +0.11/-0.005	D3	D4 ∅	D5 ∅
S	55	42	9	40	M2.5	5.5	63
M							

Overall length	H1	H2	L1	L2	L3 ±0.05	L4	L5	T1
S	76	20.5	139.4	20	2.5	9	40	8
M			164.4					

Flange size 55 – With resolver

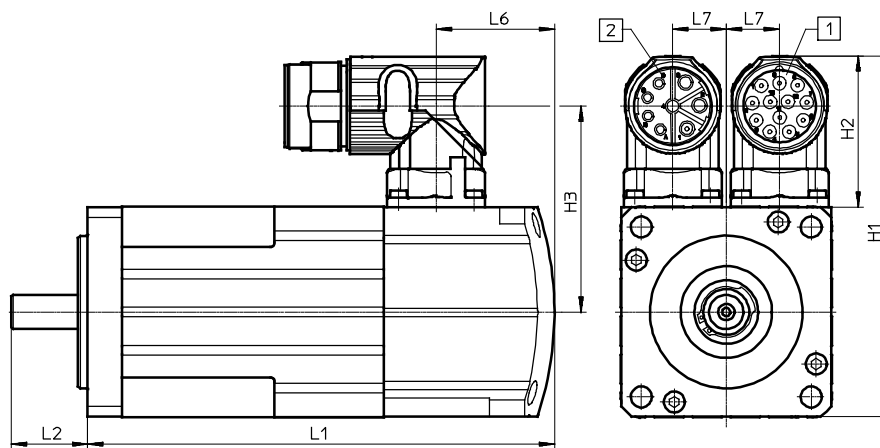

Note
 Dimensions of the shaft and mounting holes → drawing above

- 1 Resolver connection
- 2 Motor connection

Overall length	H1	H2	H3	L1		L2	L6		L7
					With brake			With brake	
S	94.7	39.7	54	122.4	139.4	20	31	48	14
M				147.4	164.4				

Servo motors EMMS-AS

Dimensions

Download CAD data → www.festo.com

Flange size 70, 100, 140, 190 – With encoder

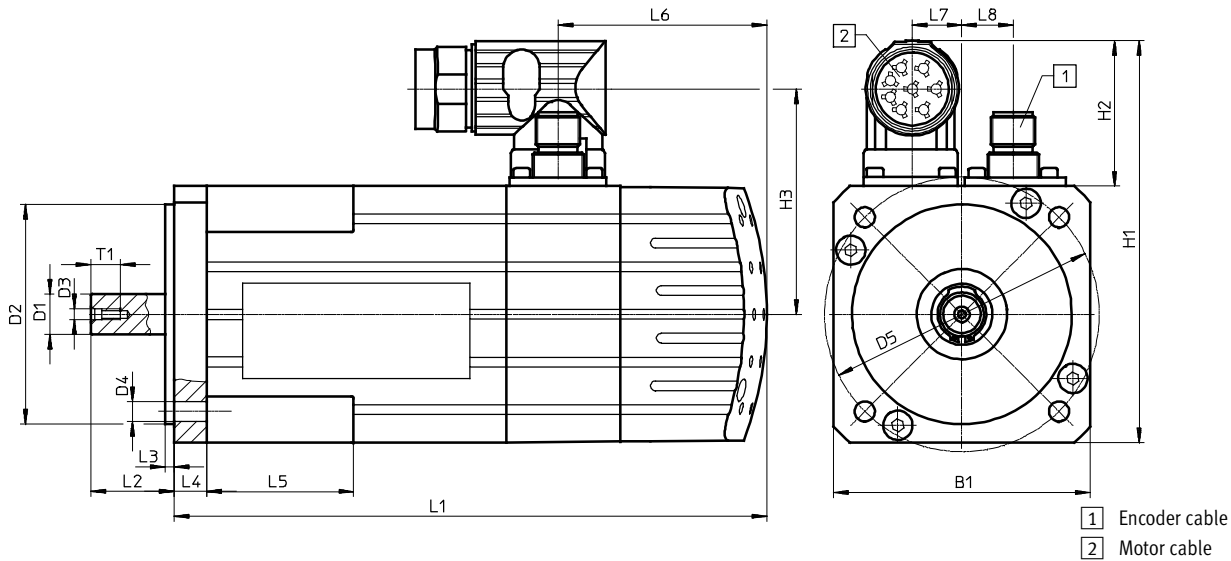

- 1 Encoder cable
- 2 Motor cable

Overall length	B1	D1 ∅	D2 ∅	D3	D4 ∅	D5 ∅	H1	H2	H3
Flange size 70									
S	70	11+0.012/+0.001	60+0.012/-0.007	M2.5	5.5	75	109.7	39.7	61.5
M									
Flange size 100									
S	100.5	19+0.015/+0.002	95+0.013/-0.009	M4	9.2	115	140	39.7	77
M									
L									
Flange size 140									
S	140.5	24+0.015/-0.002	130+0.018/-0.007	M4	11.3	165	181	39.7	97.7
L									
Flange size 190									
S	190	32+0.018/+0.002	180+0.14/-0.011	M4	13.7	215	251	61	136
M									

Overall length	L1	L2	L3	L4	L5	L6	L7	L8	T1
Flange size 70									
S	161.8	22.7	2.5-0.1	9	40	57	14	14	8
M	187.3								
Flange size 100									
S	192.3	40	3	9.8	-	58.9	19	19	16
M	243.3								
L	294.3								
Flange size 140									
S	209	50	3.5	12.2	-	58.6	33.5	33.5	16
L	285.5								
Flange size 190									
S	262	60	4-0.1	11	-	81	25	33	16
M	300								

Dimensions

Flange size 70, 100, 140, 190 – With resolver

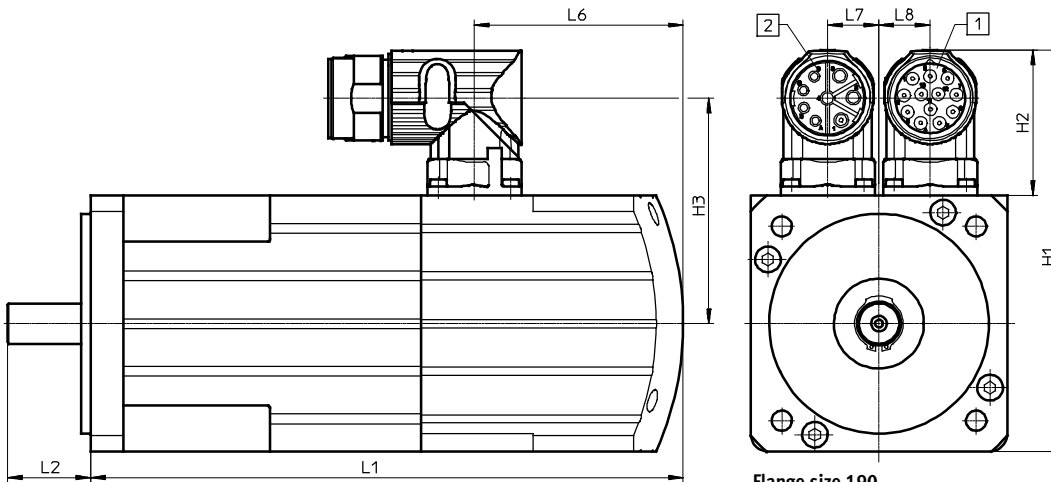

Flange size 190

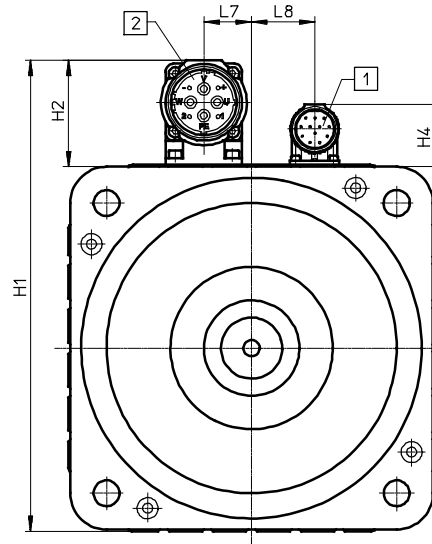

- 1 Resolver connection
- 2 Motor connection

Note
 Dimensions of the shaft and mounting holes → 432

Overall length	H1	H2	H3	H4	L1		L2	L6		L7	L8
						With brake			With brake		
Flange size 70											
S	109.7	39.7	61.5	-	139.8	161.8	22.7	35	57	14	14
M					165.3	187.3					
Flange size 100											
S	140.2	39.7	76.8	-	171.1	192.1	40	37.8	58.9	19	19
M					222.1	243.1					
L					273.1	294.1					
Flange size 140											
S	180.2	39.7	96.8	-	194.6	209	50	44.2	58.6	33.5	33.5
L					271.1	285.5					
Flange size 190											
S	244	54	128.8	33	225	262	60	44	81	25	33
M					263	300					

Note
 Only motors without feather key should be used in combination with parallel and axial kits (EAMM-U/EAMM-A).



- Motor with integrated gear unit, power electronics and position controller for operating mode with closed-loop encoder function
- Compact design
- Actuation via I/O interface and various fieldbuses
- Easy configuration with free FCT software
- Commissioning via control panel and display
- Protection class IP54
- Perfect package solution for positioning axis DMES

→ www.festo.com/catalogue/mtr-dci

Product range overview

Size	Nominal voltage [V DC]	Gear unit output torque [Nm]	Gear ratio			Interfaces			
			7:1	14:1	22:1	I/O interface	CANopen	PROFIBUS	DeviceNet
32	24	0.15/0.7	■	■	–				
42	24	0.59/1.13	■	■	–	■	■	■	■
52	24	1.62/3.08	■	■	–				
62	48	3.78/7.2/11.66	■	■	■				

Technical data

Fieldbus interfaces



CANopen

DeviceNet

Technical data		Dimensions → 438								
Size		32		42		52		62		
Gear ratio		7:1	14:1	7:1	14:1	7:1	14:1	7:1	14:1	22:1
Rotary position encoder		Optical encoder								
Number of increments/revolutions		300 (1,200) ¹⁾			500 (2,000) ¹⁾					
Nominal voltage	[V DC]	24 ±10%					48 –10%/+5%			
Nominal current	[A]	0.73		2		5		6.19		
Peak current	[A]	2.1		3.8		7.7		20		
Rated output (motor)	[W]	17		48		122		316		
Gear unit output torque	[Nm]	0.15	0.7	0.59	1.13	1.62	3.08	3.78	7.2	11.66
Gear unit output speed	[rpm]	481	237	444	218	444	218	504	248	153

1) Internal 4-fold evaluation.

Technical data

Technical data – I/O / fieldbus interface		MTR-DCI-...-IO	MTR-DCI-...-CO	MTR-DCI-...-PB	MTR-DCI-...-DN
Type					
Interface		I/O interface for 15 positioning records and homing	CANopen	PROFIBUS DP	DeviceNet
Number of digital logic inputs		6	–	–	–
Number of digital logic outputs		2	–	–	–
Max. current of digital logic outputs (size)	32/42 52/62	200 60	– –	– –	– –
Bus terminating resistor		–	Not integrated in the device	Not integrated in the device	Not integrated in the device
Communication profile		–	DS301/FHPP	DP-V0/V1 / FHPP	FHPP
		–	DS301, DSP402	Step7 functional modules	Device type 0C _h
Max. fieldbus transmission rate	[kbps]	–	1,000	12,000	500

Operating conditions

Ambient temperature	[°C]	0 ... +50
Protection class		IP54
Insulation protection class		F

Materials

Motor unit housing	Anodised aluminium
Motor unit cover	Aluminium, precision casting, coated (size 62 milled)

Torque M as a function of rotational speed n

Size 32

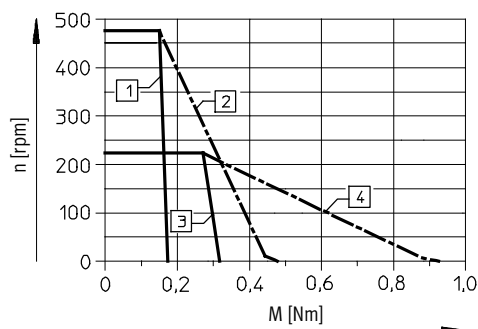

Size 42

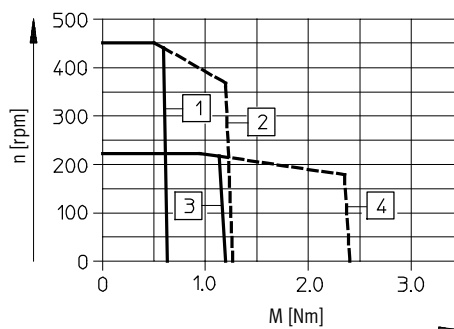

Size 52

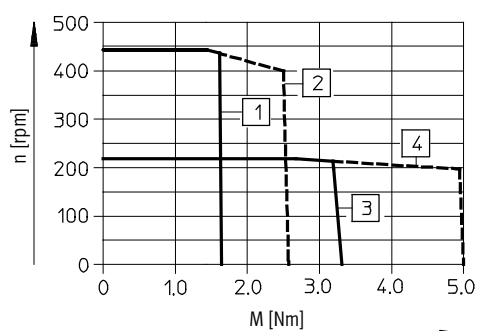

Size 62

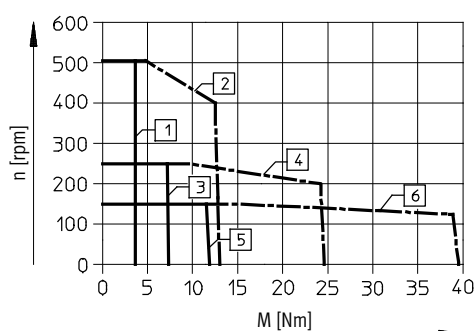

Gear unit ratio 7:1

- 1 Torque, nom.
2 Torque, max.

Gear unit ratio 14:1

- 3 Torque, nom.
4 Torque, max.

Gear unit ratio 22:1

- 5 Torque, nom.
6 Torque, max.

Order code

4

		MTR	-	DCI	-		S	-		SC	-	E	-		
Type															
MTR	Motor unit														
Motor type															
DCI	DC servo motor with integrated controller														
Size															
32	32 mm														
42	42 mm														
52	52 mm														
62	62 mm														
Torque class															
S	Standard														
Nominal voltage															
VC	24 V DC	1													
VD	48 V DC	2													
Plug design															
SC	Straight plug														
Measuring system															
E	Encoder														
Gear unit															
G7	7:1														
G14	14:1														
G22	22:1	2													
Parameterisation interface															
R2	RS232 interface														
H2	RS232 interface with control panel														
Electrical connection technology															
IO	I/O interface														
CO	CANopen interface														
PB	PROFIBUS interface														
DN	DeviceNet interface														

1 Only with size 32, 42, 52.

2 Only with size 62.

Ordering – Product options





Configurable product

This product and all its options can be ordered using the configurator.

The configurator can be found under Products on the DVD or
 → www.festo.com/catalogue/...

Enter the type code in the search field.

Accessories – Ordering data

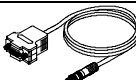
Type	Cable length		Part No.	Type
Power supply cable				
	2.5 m	★	537931	KPWR-MC-1-SUB-9HC-2,5
	5 m	★	537932	KPWR-MC-1-SUB-9HC-5
	10 m	★	537933	KPWR-MC-1-SUB-9HC-10
Control cable				
	2.5 m	★	537923	KES-MC-1-SUB-9-2,5
	5 m	★	537924	KES-MC-1-SUB-9-5
	10 m	★	537925	KES-MC-1-SUB-9-10
Programming cable				
	2.5 m	★	537926	KDI-MC-M8-SUB-9-2,5

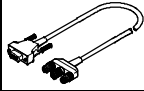
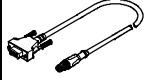
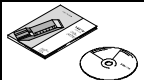
Type	Part No.	Type
Fieldbus adapter for PROFIBUS		
	537934	FBA-PB-SUB-9-3XM12
Fieldbus adapter for CANopen and DeviceNet		
	540324	FBA-CO-SUB-9-M12
Documentation and software		
	Ordering data online: → p.be-mtr-dci	

Dimensions

Size 42

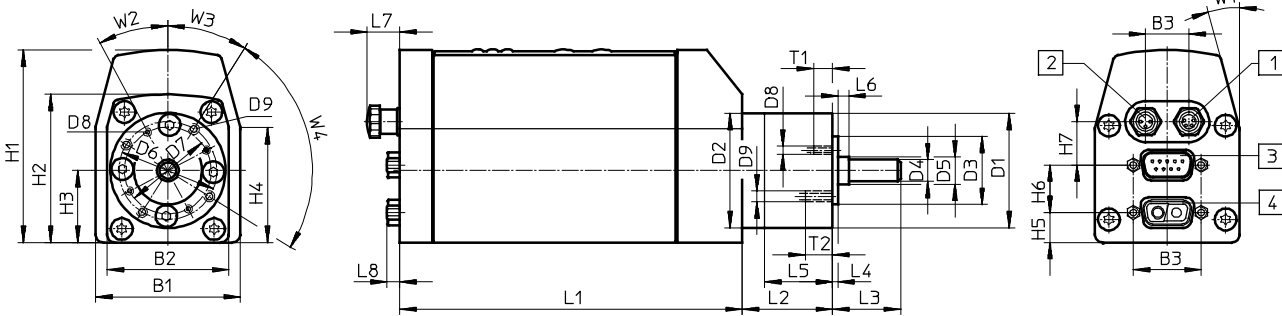

Size 32

Size 52

Size 62

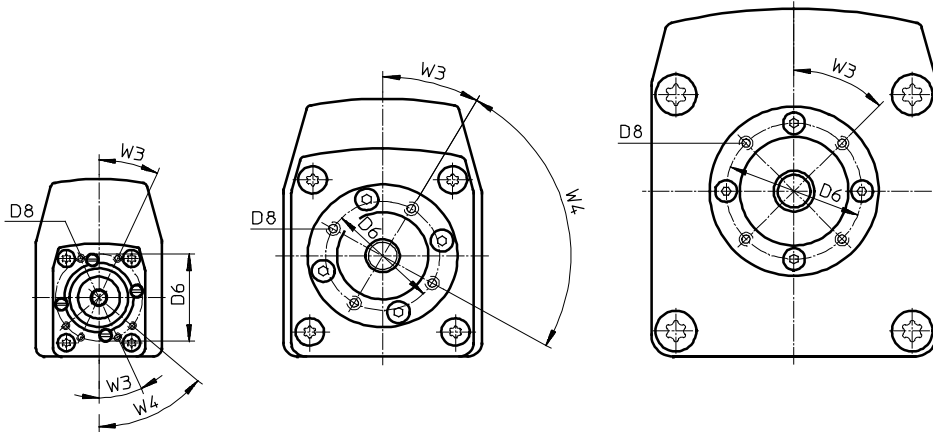

- 1 M8x1, 4-pin
2 M8x1, 3-pin

- 3 Sub-D, 9-pin
4 Sub-D, 2-pin

Type	B1	B2	B3	B4	D1	D2	D3	D4	D5	D6	D7
	±0.4		±0.15		∅ g10	∅ ±0.1	∅ h8	∅ h7	∅	∅	∅
MTR-DCI-32S-...	46.3	33.8±0.3	25	16	-	-	21.5	6	-	32	-
MTR-DCI-42S-...	53.3	44.8±0.4	-	-	42	42	25	8	-	36	32
MTR-DCI-52S-...	69.5	63.8±0.4	-	-	52	52	32	12	-	40	-
MTR-DCI-62S-...	105	-	-	-	62	62	40	14	15	50	-

Type	D8	D9	H1	H2	H3	H4	H5	H6	H7	L1
										±1
MTR-DCI-32S-...	M3	-	65.3±0.4	41.5±0.3	21.6	42.3	13±0.2	17.5	16	175.5
MTR-DCI-42S-...	M3	M4	70.8±0.4	54.5±0.4	26.5	42.3	11	17.5	16	176
MTR-DCI-52S-...	M5	-	94.8±0.4	76.5±0.4	37	60.7	17.3	17.5	16	194
MTR-DCI-62S-...	M5	-	128±0.5	-	60.8	100.8	61.3	17.5	16	270

Type	L2	L3	L4	L5	L6	L7	L8	T1	T2	W1	W2	W3	W4
	±1								+2				
MTR-DCI-32S-...-G7	-	18.7±0.6	2.5±0.3	-	-	13	5	6	-	15°	-	25°	50°
MTR-DCI-32S-...-G14	-	18.7±0.6	2.5±0.3	-	-	13	5	6	-	15°	-	25°	50°
MTR-DCI-42S-...-G7	33.3	25±1	2±0.1	25	-	13	5	7+2	10	15°	28°	32°	90°
MTR-DCI-42S-...-G14	46.3	25±1	2±0.1	25	-	13	5	7+2	10	15°	28°	32°	90°
MTR-DCI-52S-...-G7	39	33±1	3±0.3	31	-	13	5	10	-	15°	-	30°	90°
MTR-DCI-52S-...-G14	53	33±1	3±0.3	31	-	13	5	10	-	15°	-	30°	90°
MTR-DCI-62S-...-G7	47	39±1	5±0.3	31.3	9	13	5	10	-	15°	-	45°	-
MTR-DCI-62S-...-G14	47	39±1	5±0.3	31.3	9	13	5	10	-	15°	-	45°	-
MTR-DCI-62S-...-G22	47	39±1	5±0.3	31.3	9	13	5	10	-	15°	-	45°	-

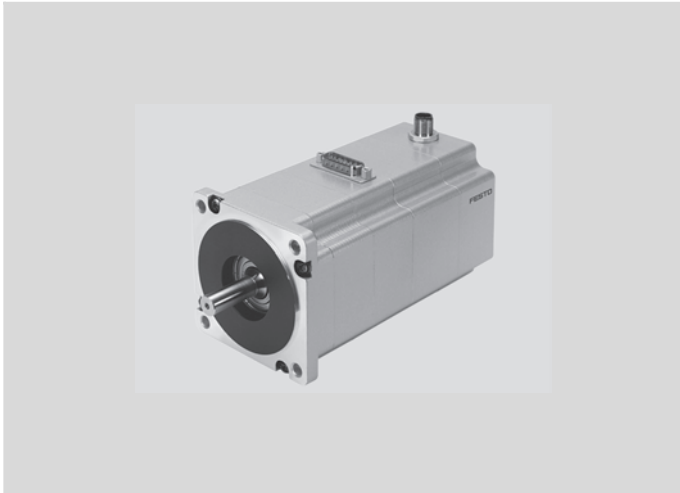

- Suitable for motor controller CMMS-ST
- Optional encoder with full closed-loop functionality
- Matching gear unit
- Protection class IP54
- ★ Quick ordering of basic designs → 442

→ www.festo.com/catalogue/emms-st

Product range overview

Motor flange size	Nominal voltage [V DC]	Holding torque [Nm]	With encoder	With gear unit	With brake
28	48	0.09	■	■	■
42	48	0.5	■	■	■
57	48	0.8 ... 1.4	■	■	■
87	48	2.5 ... 9.3	■	■	■

At a glance

Performance characteristics of the motors in combination with controllers

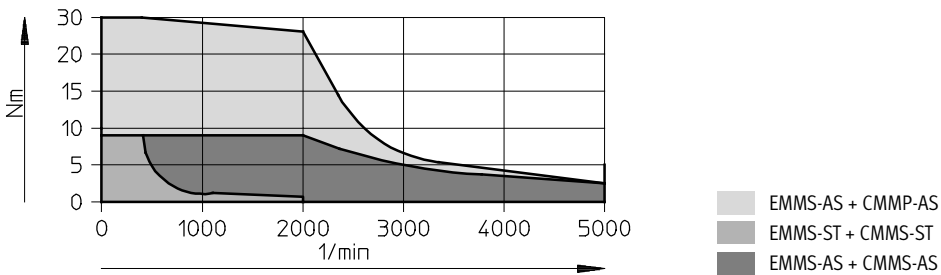

Technical data

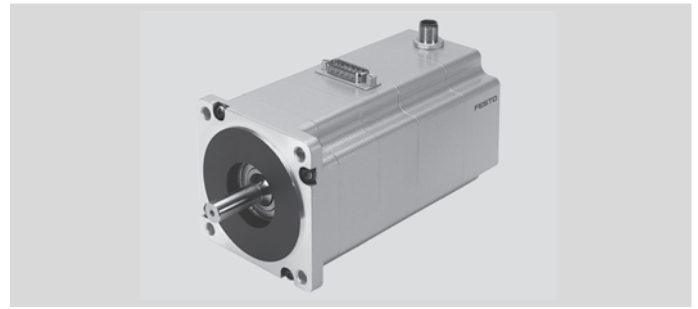

4

Technical data		Dimensions → 444						
Motor flange size		28	42	57-S	57-M	87-S	87-M	87-L
Nominal voltage	[V DC]	48						
Nominal current	[A]	1.4	1.8	5		9.5		
Holding torque	[Nm]	0.09	0.5	0.8	1.4	2.5	5.9	9.3
Step angle	[°]	1.8 +5%						
Brake								
Operating voltage	[V DC]	24 ±10%						
Holding torque	[Nm]	0.2	0.4	0.4	1	2		

Technical data – Encoder

Encoder, optical		
Operating voltage	[V DC]	5
Pulses/revolution	[1/rev]	500
Zero pulse		Yes
Line driver		RS422 protocol

Operating conditions

Motor flange size		28	42	57-S	57-M	87-S	87-M	87-L
Ambient temperature	[°C]	-10 ... +50						
Protection class: Motor shaft		IP54						
Protection class: Motor housing incl. connection technology		IP65	IP54					
Insulation protection class		B						

Technical data

Torque M as a function of rotational speed n

EMMS-ST-28

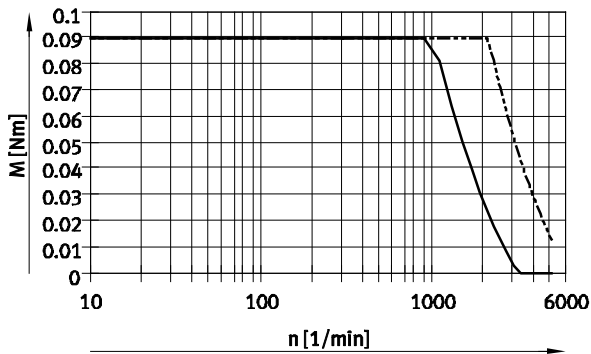

EMMS-ST-42

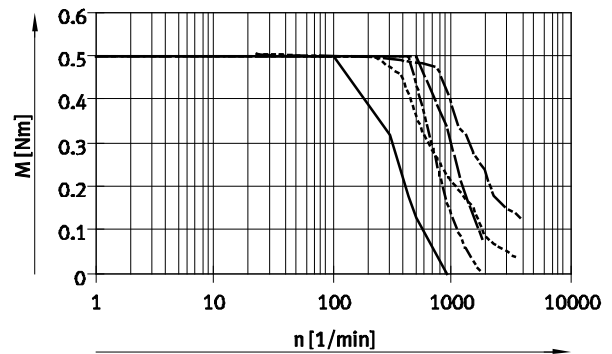

EMMS-ST-57-S

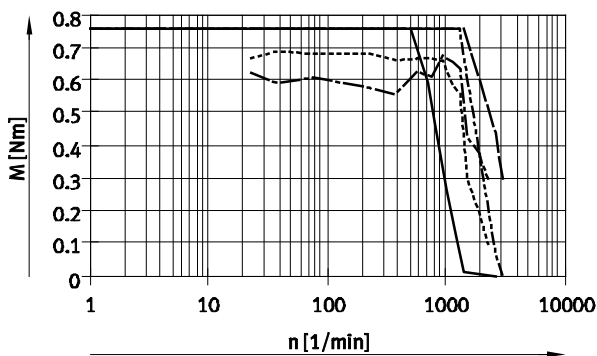

EMMS-ST-57-M

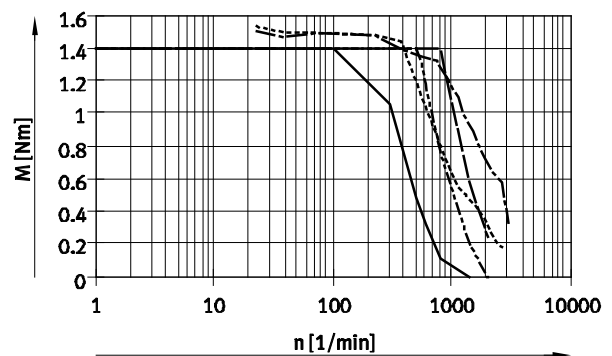

EMMS-ST-87-S

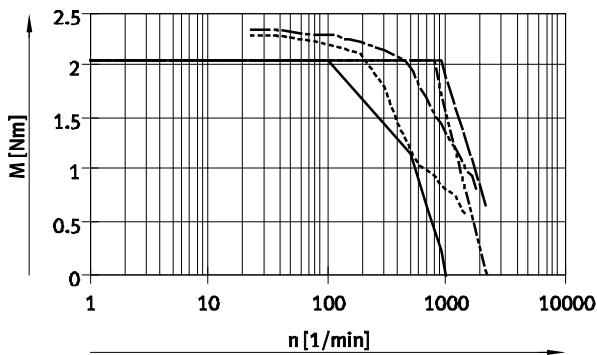

EMMS-ST-87-M

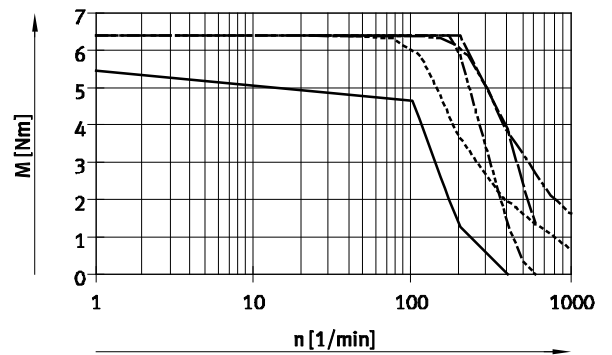

EMMS-ST-87-L

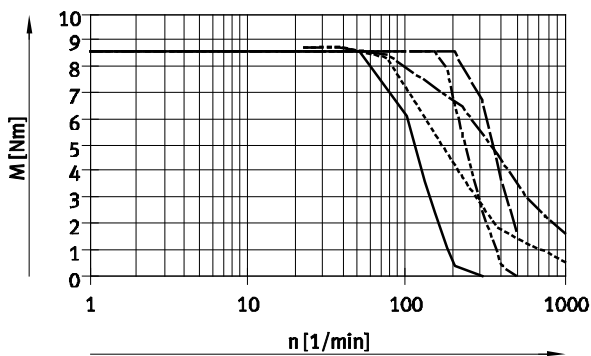

Note

The characteristic curves apply in combination with the motor controller CMMS-ST. The size EMMS-ST-87 is operated with the motor controller CMMS-ST with max. 8 A.

- 24 V DC
- - - 48 V DC
- · - · 72 V DC
- · - · - · 24 V DC 1/4 step
- · - · - · - · 48 V DC 1/4 step

4

Order code

EMMS		ST						S							
Type															
EMMS		Motor													
Motor technology															
ST		Stepper motor													
Motor flange size															
28		Motor size 28										1			
42		Motor size 42										2			
57		Motor size 57										3			
87		Motor size 87													
Length															
S		Short													
M		Medium													
L		Long													
Electrical connection															
S		Straight plug													
Measuring unit															
-		Not specified													
E		Encoder													
Brake															
-		Not specified													
B		Brake													
Generation															
G2		Second generation										4			

1 Only with length L.

3 Only with length S and M.

2 Only with length S.

4 Not with flange size 28.

Ordering – Product options

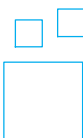

Configurable product

This product and all its options can be ordered using the configurator.

The configurator can be found under Products on the DVD or

→ www.festo.com/catalogue/...

Enter the type code in the search field.

★ Quick ordering

Part No.	Type
Flange size 28, long length	
1451384	EMMS-ST-28-L-S
1430663	EMMS-ST-28-L-SE
1451383	EMMS-ST-28-L-SB
1451382	EMMS-ST-28-L-SEB
Flange size 42, short length	
1370470	EMMS-ST-42-S-S-G2
1370471	EMMS-ST-42-S-SE-G2
1370472	EMMS-ST-42-S-SB-G2
1370473	EMMS-ST-42-S-SEB-G2

Part No.	Type
Flange size 57, short length	
1370474	EMMS-ST-57-S-S-G2
1370475	EMMS-ST-57-S-SE-G2
1370476	EMMS-ST-57-S-SB-G2
1370477	EMMS-ST-57-S-SEB-G2
Flange size 57, medium length	
1370478	EMMS-ST-57-M-S-G2
1370479	EMMS-ST-57-M-SE-G2
1370480	EMMS-ST-57-M-SB-G2
1370481	EMMS-ST-57-M-SEB-G2

Part No.	Type
Flange size 87, short length	
1370482	EMMS-ST-87-S-S-G2
1370483	EMMS-ST-87-S-SE-G2
1370484	EMMS-ST-87-S-SB-G2
1370485	EMMS-ST-87-S-SEB-G2
Flange size 87, medium length	
1370486	EMMS-ST-87-M-S-G2
1370487	EMMS-ST-87-M-SE-G2
1370488	EMMS-ST-87-M-SB-G2
1370489	EMMS-ST-87-M-SEB-G2
Flange size 87, long length	
1370490	EMMS-ST-87-L-S-G2
1370491	EMMS-ST-87-L-SE-G2
1370493	EMMS-ST-87-L-SB-G2
1370494	EMMS-ST-87-L-SEB-G2

Accessories – Ordering data

Motor cable

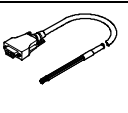
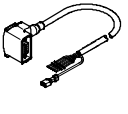
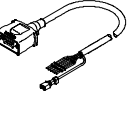
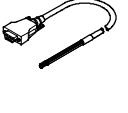
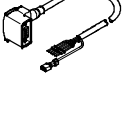
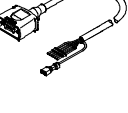
	Cable length		Part No.	Type
For EMMS-ST-28				
and motor controller CMMO-ST				
Straight plug				
	1.5 m	★	1449600	NEBM-M12G8-E-1.5-Q5-LE6
	2.5 m	★	1449601	NEBM-M12G8-E-2.5-Q5-LE6
	5 m	★	1449602	NEBM-M12G8-E-5-Q5-LE6
	7 m	★	1449603	NEBM-M12G8-E-7-Q5-LE6
	10 m	★	1449604	NEBM-M12G8-E-10-Q5-LE6
	X length ¹⁾	★	1449605	NEBM-M12G8-E--Q5-LE6
For EMMS-ST-42/57				
and motor controller CMMS-ST				
Straight plug				
	5 m	★	550740	NEBM-S1G9-E-5-LE6
	10 m	★	550741	NEBM-S1G9-E-10-LE6
	15 m	★	550742	NEBM-S1G9-E-15-LE6
	X length ¹⁾		550743	NEBM-S1G9-E--LE6
And motor controller CMMO-ST				
Angled plug				
	1.5 m	★	1450736	NEBM-S1W9-E-1.5-Q5-LE6
	2.5 m	★	1450737	NEBM-S1W9-E-2.5-Q5-LE6
	5 m	★	1450738	NEBM-S1W9-E-5-Q5-LE6
	7 m	★	1450739	NEBM-S1W9-E-7-Q5-LE6
	10 m	★	1450740	NEBM-S1W9-E-10-Q5-LE6
	X length ¹⁾	★	1450741	NEBM-S1W9-E--Q5-LE6
Straight plug				
	1.5 m		1450368	NEBM-S1G9-E-1.5-Q5-LE6
	2.5 m		1450369	NEBM-S1G9-E-2.5-Q5-LE6
	5 m		1450370	NEBM-S1G9-E-5-Q5-LE6
	7 m		1450371	NEBM-S1G9-E-7-Q5-LE6
	10 m		1450372	NEBM-S1G9-E-10-Q5-LE6
	X length ¹⁾		1450373	NEBM-S1G9-E--Q5-LE6
For EMMS-ST-87				
and motor controller CMMS-ST				
Straight plug				
	5 m	★	550744	NEBM-S1G15-E-5-LE6
	10 m	★	550745	NEBM-S1G15-E-10-LE6
	15 m	★	550746	NEBM-S1G15-E-15-LE6
	X length ¹⁾		550747	NEBM-S1G15-E--LE6
And motor controller CMMO-ST				
Angled plug				
	1.5 m	★	1450943	NEBM-S1W15-E-1.5-Q7-LE6
	2.5 m	★	1450944	NEBM-S1W15-E-2.5-Q7-LE6
	5 m	★	1450945	NEBM-S1W15-E-5-Q7-LE6
	7 m	★	1450946	NEBM-S1W15-E-7-Q7-LE6
	10 m	★	1450947	NEBM-S1W15-E-10-Q7-LE6
	X length ¹⁾	★	1450948	NEBM-S1W15-E--Q7-LE6
Straight plug				
	1.5 m		1450834	NEBM-S1G15-E-1.5-Q7-LE6
	2.5 m		1450835	NEBM-S1G15-E-2.5-Q7-LE6
	5 m		1450836	NEBM-S1G15-E-5-Q7-LE6
	7 m		1450837	NEBM-S1G15-E-7-Q7-LE6
	10 m		1450838	NEBM-S1G15-E-10-Q7-LE6
	X length ¹⁾		1450839	NEBM-S1G15-E--Q7-LE6

Encoder cable

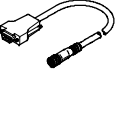
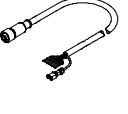
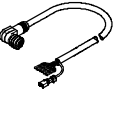
	Cable length		Part No.	Type
Straight plug				
for motor controller CMMS-ST				
	5 m	★	550748	NEBM-M12G8-E-5-S1G9
	10 m	★	550749	NEBM-M12G8-E-10-S1G9
	15 m	★	550750	NEBM-M12G8-E-15-S1G9
	X length ¹⁾		550751	NEBM-M12G8-E--S1G9
For motor controller CMMO-ST				
Straight plug				
	1.5 m	★	1451586	NEBM-M12G8-E-1.5-LE8
	2.5 m	★	1451587	NEBM-M12G8-E-2.5-LE8
	5 m	★	1451588	NEBM-M12G8-E-5-LE8
	7 m	★	1451589	NEBM-M12G8-E-7-LE8
	10 m	★	1451590	NEBM-M12G8-E-10-LE8
X length ¹⁾	★	1451591	NEBM-M12G8-E--LE8	
Angled plug				
	1.5 m	★	1451674	NEBM-M12W8-E-1.5-LE8
	2.5 m	★	1451675	NEBM-M12W8-E-2.5-LE8
	5 m	★	1451676	NEBM-M12W8-E-5-LE8
	7 m	★	1451677	NEBM-M12W8-E-7-LE8
	10 m	★	1451678	NEBM-M12W8-E-10-LE8
X length ¹⁾	★	1451679	NEBM-M12W8-E--LE8	

1) Max. 25 m. Cable lengths > 25 m possible following technical clarification; up to 100 m on request. Available in 0.1 m increments.

Stepper motors EMMS-ST

Dimensions

Size 28

EMMS-ST-...-S/SE

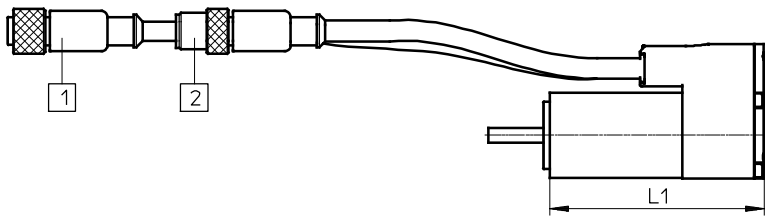

4

EMMS-ST-...-SB/SEB

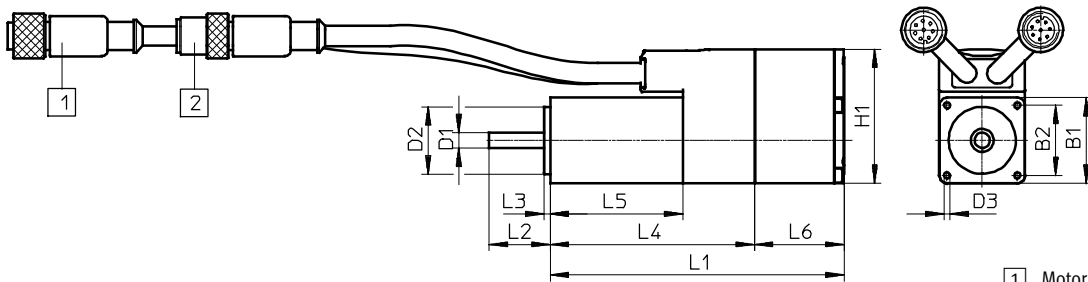

- 1 Motor cable
- 2 Encoder cable

Type	B1	B2	D1 ∅	D2 ∅	D3	H1
	±1	±0.2	-0.013	-0.03		
EMMS-ST-28-L-S	28	23	5	22	M2.5x4.5	44
EMMS-ST-28-L-SE						
EMMS-ST-28-L-SB						
EMMS-ST-28-L-SEB						

Type	L1	L2	L3	L4	L5	L6
		±1		±1	±1	±0.5
EMMS-ST-28-L-S	70±1	20	2	67	43	29
EMMS-ST-28-L-SE						
EMMS-ST-28-L-SB						
EMMS-ST-28-L-SEB						

Dimensions

Size 42, 57, 87

EMMS-ST...-S

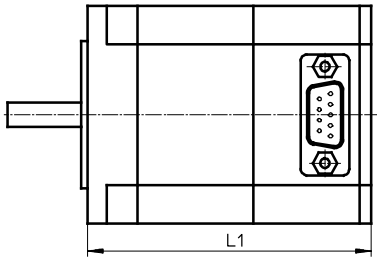

EMMS-ST...-SB

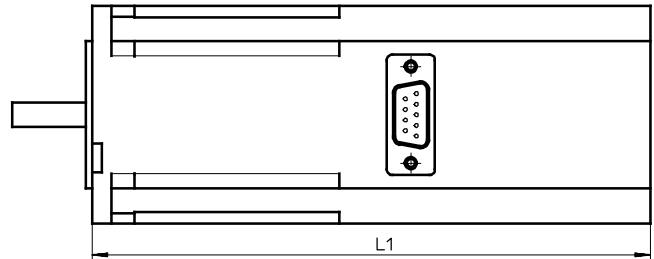

EMMS-ST...-SE/SEB

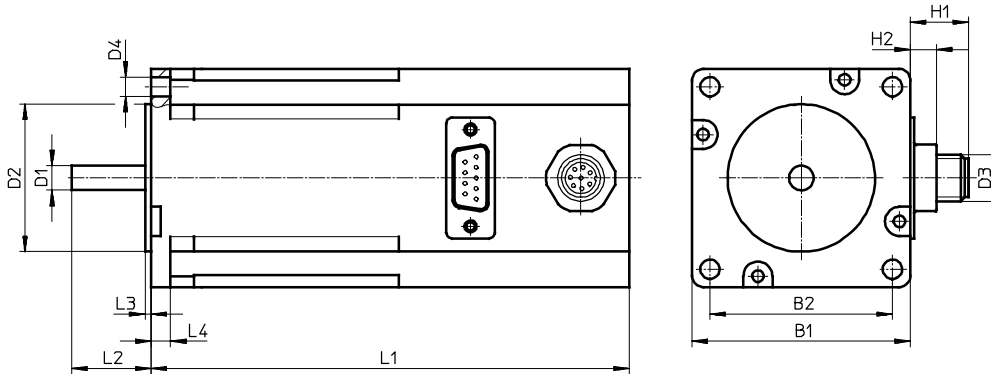

Plug pattern

9-pin Sub-D plug with size 42, 57

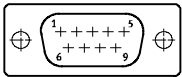

15-pin Sub-D plug with size 87

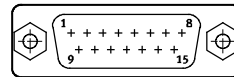

Type	B1	B2	D1 ∅	D2 ∅	D3	D4 ∅	H1	H2	L1	L2	L3	L4
EMMS-ST-42-S-S-G2	42.3	31	5-0.012	22-0.05	-	M3x4.5	-	6.5	66±1	24±1	2	-
EMMS-ST-42-S-SE-G2					M12		13		94±1.2			
EMMS-ST-42-S-SB-G2					-		-		114±1.3			
EMMS-ST-42-S-SEB-G2					M12		13		127±1.3			
EMMS-ST-57-S-S-G2	56.4	47.14	6.35-0.013	38.1±0.025	-	5	-	6.5	73.5±0.8	20.6±0.5	1.6	5
EMMS-ST-57-S-SE-G2					M12		13		102.5±1.1			
EMMS-ST-57-S-SB-G2					-		-		123.5±1.1			
EMMS-ST-57-S-SEB-G2					M12		13		138±1.1			
EMMS-ST-57-M-S-G2					-		-		95±0.8			
EMMS-ST-57-M-SE-G2					M12		13		124±1.1			
EMMS-ST-57-M-SB-G2					-		-		145±1.1			
EMMS-ST-57-M-SEB-G2					M12		13		159.5±1.1			
EMMS-ST-87-S-S-G2	85.85	69.5	11-0.013	73-0.046	-	6.6	-	6.5	82.6±1	27±1	2	8.38
EMMS-ST-87-S-SE-G2					M12		13		112.6±1.3			
EMMS-ST-87-S-SB-G2					-		-		132.6±1.3			
EMMS-ST-87-S-SEB-G2					M12		13		152.6±1.3			
EMMS-ST-87-M-S-G2					-		-		114.9±1			
EMMS-ST-87-M-SE-G2					M12		13		144.9±1.3			
EMMS-ST-87-M-SB-G2					-		-		164.9±1.3			
EMMS-ST-87-M-SEB-G2					M12		13		184.9±1.3			
EMMS-ST-87-L-S-G2					-		-		144.9±1			
EMMS-ST-87-L-SE-G2					M12		13		174.9±1.3			
EMMS-ST-87-L-SB-G2					-		-		194.9±1.3			
EMMS-ST-87-L-SEB-G2					M12		13		214.9±1.3			



- Double controller for actuating two independent servo motors
- Motor current of 2x 4 A can be freely distributed between two controllers (with ratios of up to 2 A/6 A)
- Closed-loop operation with speed, position, current and torque control
- Integrated SD card slot
- Compatible with motor EMMS-AS
- Easy configuration with free FCT software
- ★ Quick ordering of basic designs → 449

→ www.festo.com/catalogue/cmmd-as

Product range overview

Type	Nominal voltage Load [V AC]	Nominal voltage Logic [V DC]	Interfaces			
			I/O interface	CANopen	PROFIBUS	DeviceNet
CMMD-AS-C8-3A	95 ... 255	24	■	■	■	■

Features

Compactness

- The double motor controller CMMD-AS consists of two identical motor controllers CMMS-AS in one housing
- Intermediate circuits are connected internally
- Braking resistors are connected in parallel internally so that twice the continuous braking power is available
- Combined nominal current of 8 A. The nominal current can be flexibly shared between the axes
- Small dimensions
- Full integration of all components for the controller and power section, including RS232 and CANopen interface
- Integrated brake chopper
- Integrated EMC filters
- Automatic actuation for a holding brake
- Complies with the current CE and EN standards without additional external measures (motor cable length of up to 15 m)

Motion control

- Digital absolute angle encoder in single-turn and multi-turn versions
- Can be operated as a torque, speed or position controller
- Integrated position controller
- Time-optimised (trapezoidal) or jerk-free (S-shaped) positioning
- Absolute and relative movements
- Point-to-point positioning with and without motion path smoothing
- Position synchronisation
- Electronic gear unit
- 2x 63 positioning records
- 2x 8 positioning profiles
- Wide range of homing methods

Fieldbus interfaces

Integrated:



Optional:



Input/output

- Freely programmable I/Os
- High-resolution 12-bit analogue input
- Jog/teach mode
- Simple connection to a higher-order controller via I/O or fieldbus
- Synchronous operation
- Master/slave mode
- Additional I/Os with the plug-in card CAMC-D-8E8A

Integrated sequence control

- Automatic sequence of positioning records without a higher-order controller
- Linear and cyclical position sequences
- Adjustable delay times

Integrated safety functions

- The motor controller CMMD-AS supports the "Safe Torque Off (STO)" safety function and, by providing a reliable time delay, also supports "Safe Stop 1 (SS1)" with protection against unexpected start-up in accordance with EN 61800-5-2
- Protection against unexpected start-up
- Two-channel disconnection of the output stage
- Less external circuitry
- Shorter response times in the event of an error
- Faster restart, intermediate circuit remains charged

Interpolating multi-axis movement

- With a suitable controller, the CMMD-AS can perform path movements with interpolation via CANopen. To do this, setpoint position values are specified by the controller in a fixed time slot pattern. In between, the servo position controller independently interpolates the data values between two data points.

Features

Travel program

- Linking of any number of position sets into a travel program
- Step criteria for the travel program possible via digital inputs, for example
MC – motion complete
I/O – digital inputs

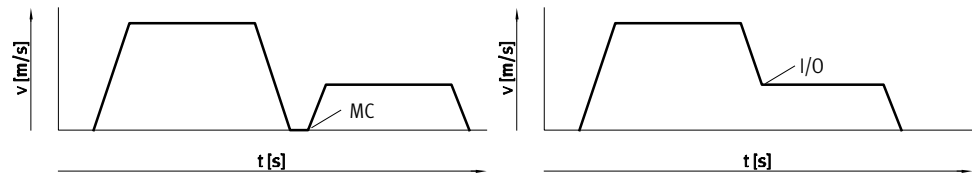

Library for EPLAN



EPLAN macros for fast and reliable planning of electrical projects in combination with motor controllers,

motors and cables. This enables a high level of planning reliability, standardisation of

documentation, no need to create symbols, graphics and master data.

4

System overview

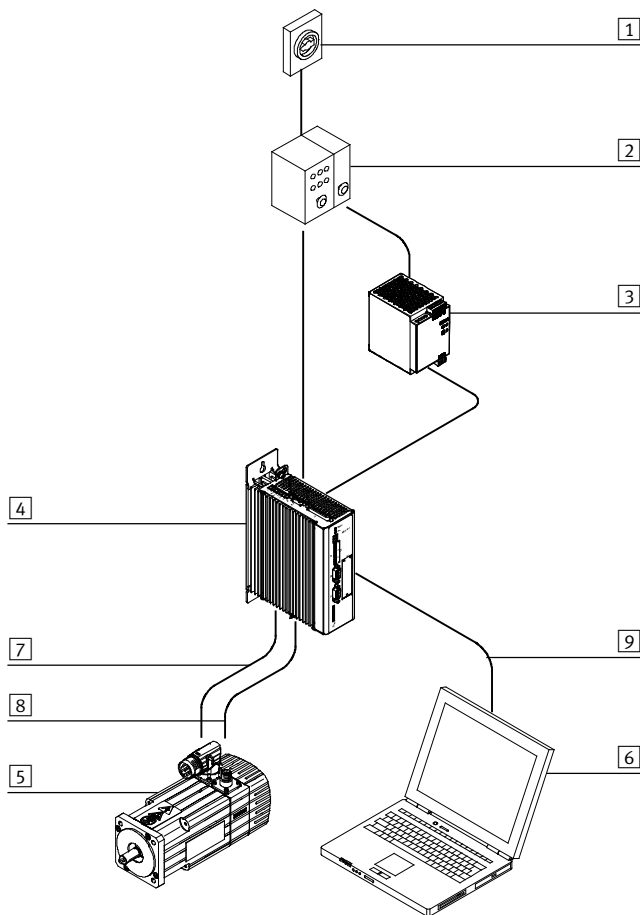

- 1 Power switch
- 2 Circuit breaker
- 3 24 V DC power supply unit
- 4 Motor controller CMMD-AS
- 5 Motor EMMS-AS
- 6 PC
- 7 Encoder cable
- 8 Motor cable
- 9 Programming cable

Technical data

Fieldbus interfaces

CANopen

PROFIBUS DP

DeviceNet



4

Technical data

Download CAD data → www.festo.com

Rotary position encoder		Encoder
Parameterisation interface		RS232 (9,600 ... 115,000 bits/s)
Encoder interface input		Setpoint position value as encoder signal EnDat V2.1 serial/V2.2
Encoder interface output		Actual value feedback via encoder signals in speed control mode Setpoint specification for downstream slave drive Resolution 4,096 ppr
Braking resistor, integrated	[Ω]	115
Pulse power of braking resistor	[kVA]	1.4
Number of analogue outputs		2
Operating range of analogue outputs	[V]	0 ... 10
Resolution of analogue outputs	[bit]	8
Number of analogue inputs		2
Operating range of analogue inputs	[V]	±10
Mains filter		Integrated

Electrical data

Load supply		
Input voltage range	[V AC]	95 ... 255
Max. nominal input current	[A]	10
Rated output	[VA]	1,200
Peak power	[VA]	2,400
Logic supply		
Nominal voltage	[V DC]	24 ±20%
Nominal current	[A]	0.7

Operating conditions

Ambient temperature	[°C]	0 ... +50
Protection class		IP20
Certificate issuing authority		BG MFS 10009
Safety function		Safe Torque Off (STO)
Safety integrity level (SIL)		SIL 2
Performance Level (PL)		Safe Torque Off (STO)/category 3, Performance Level d

Technical data – Fieldbus interface

Interfaces	I/O	CANopen	PROFIBUS DP	DeviceNet
Number of digital logic outputs		10		
Characteristics of digital logic outputs		Freely configurable in some cases		
Number of digital logic inputs		28		
Operating range of logic inputs	[V]	12 ... 30		
Characteristics of logic inputs		Freely configurable		
Process coupling		For 2x 63 position. records	For 2x 63 positioning records	
Communication profile		–	DS301, FHPP	FHPP
		–	DS301, DSP402	
Max. fieldbus transmission rate	[Mbps]	–	1	12
Interface	Integrated	■	■	–
	Optional	–	–	■ → 449

Ordering – Product options

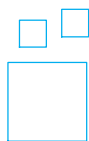

Configurable product

This product and all its options can be ordered using the configurator.

The configurator can be found under Products on the DVD or

→ www.festo.com/catalogue/...

Enter the type code in the search field.

★ Quick ordering

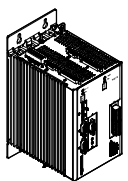
	Description	Part No.	Type
	The plug assortment NEKM (→ 449) is included in the scope of delivery of the motor controller.	561406	CMMD-AS-C8-3A

Accessories – Ordering data

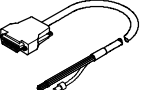
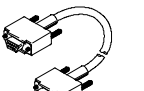
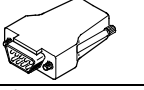
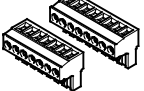
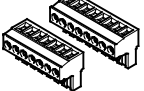
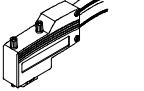
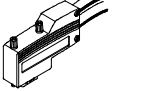
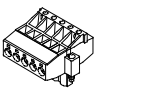
	Part No.	Type
Cable and plug		
Control cable, for I/O interface to any controller		
	552254	NEBC-S1G25-K-2.5N-LE26
Programming cable		
	160786	PS1-ZK11-NULLMODEM-1,5M
Encoder plug		
	564264	NECC-A-S-S1G9-C2M
Plug assortment		
	For CMMD	
	560504	NEKM-C-4 ¹⁾
	For CAMC-D-8E8A	
	569959	NEKM-C-5 ²⁾
Plug		
	For PROFIBUS interface	
	533780	FBS-SUB-9-WS-PB-K
	For CANopen interface	
	533783	FBS-SUB-9-WS-CO-K
Plug, for DeviceNet interface		
	525635	FBSD-KL-2X5POL

1) Plug for power supply and plug for motor connection. Plugs are included in the scope of delivery of the motor controller.

2) Plugs are included in the scope of delivery of the plug-in card CAMC-D-8E8A.

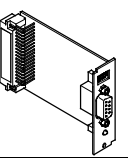
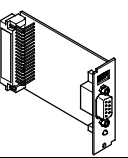
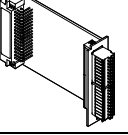
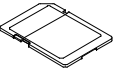
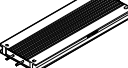
	Part No.	Type
Plug-in card		
	Interface, for PROFIBUS interface	
	★ 547450	CAMC-PB
	Interface, for DeviceNet interface	
	★ 547451	CAMC-DN
Plug-in card³⁾		
Interface, for extending the digital I/Os		
	567855	CAMC-D-8E8A
Memory card for data backup and firmware download		
	1436343	CAMC-M-S-F10-V1
Braking resistor		
	1336611	CACR-LE2-72-W500

3) Plugs are included in the scope of delivery (8 digital inputs/outputs).

	Type
Documentation and software	
	Ordering data → online: cmmd



- Optimised performance for standard applications
- Closed-loop operation with speed, position, current and torque control
- Integrated SD card slot
- Compatible with motor EMMS-AS
- Easy configuration with free FCT software
- ★ Quick ordering of basic designs → 453

→ www.festo.com/catalogue/cmms-as

Product range overview

Type	Nominal voltage Load [V AC]	Nominal voltage Logic [V DC]	Interfaces			
			I/O interface	CANopen	PROFIBUS	DeviceNet
CMMS-AS-C4-3A-G2	95 ... 255	24	■	■	■	■

Features

Compactness

- Small dimensions
- Full integration of all components for the controller and power section, including RS232 and CANopen interface
- Integrated brake chopper
- Integrated EMC filters
- Automatic actuation for a holding brake
- Complies with the current CE and EN standards without additional external measures (motor cable length of up to 15 m)

Motion control

- Digital absolute angle encoder in single-turn and multi-turn versions
- Can be operated as a torque, speed or position controller
- Integrated position controller
- Time-optimised (trapezoidal) or jerk-free (S-shaped) positioning
- Absolute and relative movements
- Point-to-point positioning with and without motion path smoothing
- Position synchronisation
- Electronic gear unit
- 63 positioning records
- 8 positioning profiles
- Wide range of homing methods

Fieldbus interfaces

Integrated:

CANopen

Optional:

PROFI
PROFIBUS

DeviceNet
CONFORMANCE TESTED

Input/output

- Freely programmable I/Os
- High-resolution 12-bit analogue input
- Jog/teach mode
- Simple connection to a higher-order controller via I/O or fieldbus
- Synchronous operation
- Master/slave mode

Integrated sequence control

- Automatic sequence of positioning records without a higher-order controller
- Linear and cyclical position sequences
- Adjustable delay times

Integrated safety functions

- The motor controller CMMS-AS supports the "Safe Torque Off (STO)" safety function and, by providing a reliable time delay, also supports "Safe Stop 1 (SS1)" with protection against unexpected start-up in accordance with EN 61800-5-2
- Protection against unexpected start-up
- Two-channel disconnection of the output stage
- Less external circuitry
- Shorter response times in the event of an error
- Faster restart, intermediate circuit remains charged

Interpolating multi-axis movement

- With a suitable controller, the CMMS-AS can perform path movements with interpolation via CANopen. The controller specifies setpoint position values in a fixed time pattern

to this end. In between, the servo position controller independently interpolates the data values between two data points.

Features

Travel program

- Linking of any number of position sets into a travel program
- Step criteria for the travel program possible via digital inputs, for example
MC – motion complete
I/O – digital inputs

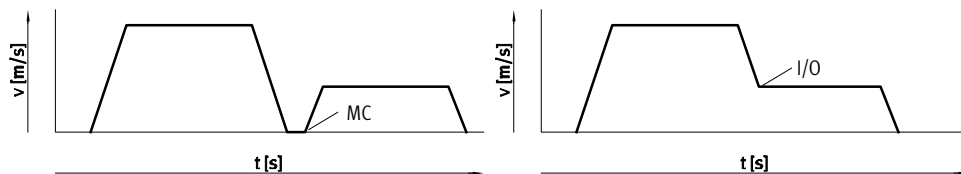

Library for EPLAN



EPLAN macros for fast and reliable planning of electrical projects in combination with motor controllers,

motors and cables. This enables a high level of planning reliability, standardisation of

documentation, no need to create symbols, graphics and master data.

System overview

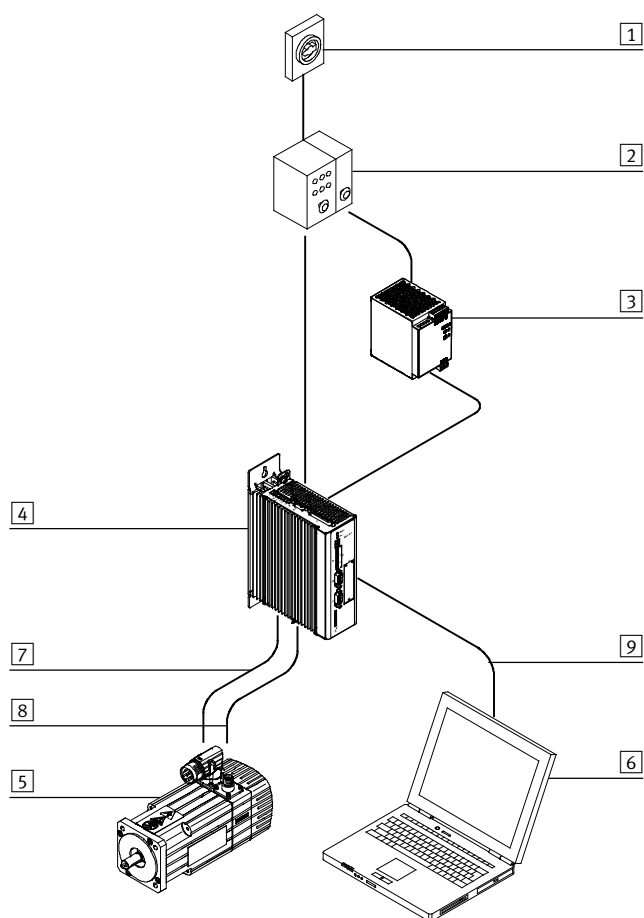

- 1 Power switch
- 2 Circuit breaker
- 3 24 V DC power supply unit
- 4 Motor controller CMMS-AS
- 5 Motor EMMS-AS
- 6 PC
- 7 Encoder cable
- 8 Motor cable
- 9 Programming cable

Technical data

Fieldbus interfaces

CANopen

PROFI[®]
PROCESSING UNITDeviceNet[™]
CONFORMANCE TESTED

4

Technical data

Download CAD data → www.festo.com

Rotary position encoder		Encoder
Parameterisation interface		RS232 (9,600 ... 115,000 bits/s)
Encoder interface input		Setpoint position value as encoder signal EnDat V2.1 serial/V2.2
Encoder interface output		Actual value feedback via encoder signals in speed control mode Setpoint specification for downstream slave drive Resolution 4,096 ppr
Braking resistor, integrated	[Ω]	230
Pulse power of braking resistor	[kVA]	0.7
Number of analogue outputs		1
Operating range of analogue outputs	[V]	0 ... 10
Resolution of analogue outputs	[bit]	8
Number of analogue inputs		1
Operating range of analogue inputs	[V]	±10
Mains filter		Integrated

Electrical data

Load supply		
Input voltage range	[V AC]	95 ... 255
Max. nominal input current	[A]	4
Rated output	[VA]	600
Peak power	[VA]	1,200
Logic supply		
Nominal voltage	[V DC]	24 ±20%
Nominal current	[A]	0.35

Operating conditions

Ambient temperature	[°C]	0 ... +50
Protection class		IP20
Certificate issuing authority		BG MFS 09030
Safety function		Safe Torque Off (STO)
Safety integrity level (SIL)		SIL 2
Performance Level (PL)		Safe Torque Off (STO)/category 3, Performance Level d

Technical data – Fieldbus interface

Interfaces	I/O	CANopen	PROFIBUS DP	DeviceNet
Number of digital logic outputs		5		
Characteristics of digital logic outputs		Freely configurable in some cases		
Number of digital logic inputs		14		
Operating range of logic inputs	[V]	12 ... 30		
Characteristics of logic inputs		Freely configurable		
Process coupling		For 63 positioning records	For 63 positioning records	
Communication profile		–	DS301, FHPP	DP-V0/FHPP
		–	DS301, DSP402	–
Max. fieldbus transmission rate	[Mbps]	–	1	12
Interface	Integrated	■	■	–
	Optional	–	–	■ → 453

Ordering – Product options

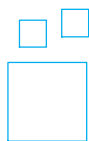

Configurable
product

This product and all its options can
be ordered using the configurator.

The configurator can be found under
Products on the DVD or
→ www.festo.com/catalogue/...

Enter the type code in the search field.

★ Quick ordering

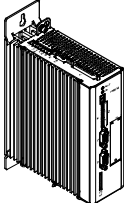
	Description	Part No.	Type
	The plug assortment NEKM (→ 453) is included in the scope of delivery of the motor controller.	572986	CMMS-AS-C4-3A-G2

Accessories – Ordering data

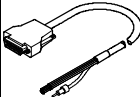
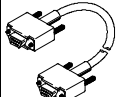
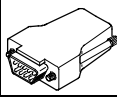
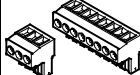
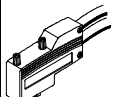
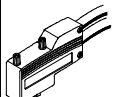
	Part No.	Type
Cable and plug		
Control cable, for I/O interface to any controller		
	552254	NEBC-S1G25-K-2.5N-LE26
Programming cable		
	160786	PS1-ZK11-NULLMODEM-1,5M
Encoder plug		
	564264	NECC-A-S-S1G9-C2M
Plug assortment		
	560504	NEKM-C-4 ¹⁾
Plug		
	For PROFIBUS interface	
	533780	FBS-SUB-9-WS-PB-K
	For CANopen interface	
	533783	FBS-SUB-9-WS-CO-K

1) Comprising plug for power supply and plug for motor connection.
Plugs are included in the scope of delivery of the motor controller.

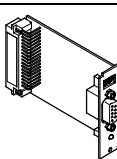
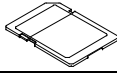
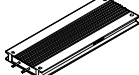
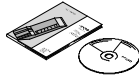
	Part No.	Type
Cable and plug		
Plug, for DeviceNet interface		
	525635	FBSD-KL-2X5POL
Plug-in card		
	Interface, for PROFIBUS interface	
	★ 547450	CAMC-PB
	Interface, for DeviceNet interface	
★ 547451	CAMC-DN	
Memory card for data backup and firmware download		
	1436343	CAMC-M-S-F10-V1
Braking resistor		
	1336615	CACR-LE2-100-W500
Documentation and software		
	Ordering data → online: cmms	



- Closed-loop operation with speed, position, current and torque control
- Optional operation of linear motors
- Compatible with motor EMMS-AS
- Easy configuration with free FCT software
- ★ Quick ordering of basic designs → 458

4

→ www.festo.com/catalogue/cmmp-as

Product range overview

Type	Nominal voltage Load [V AC]	Nominal voltage Logic [V DC]	Interfaces						
			I/O interface	CANopen	PROFIBUS DP	DeviceNet	EtherCAT	EtherNet/IP	PROFINET RT
CMMP-AS-C2-...	100 ... 230	24	■	■	■	■	■	■	■
CMMP-AS-C5-3A-...	100 ... 230	24	■	■	■	■	■	■	■
CMMP-AS-C5-11A-...	3x 230 ... 480	24	■	■	■	■	■	■	■
CMMP-AS-C10-...	3x 230 ... 480	24	■	■	■	■	■	■	■
CMMP-AS-C20-...	3x 230 ... 480	24	■	■	■	■	■	-	-

Features

Compactness

- Small dimensions
- Full integration of all components for the controller and power section, including RS232 and CANopen interface
- Integrated brake chopper
- Integrated EMC filters
- Automatic actuation for a holding brake
- Complies with the current CE and EN standards without additional external measures (motor cable length of up to 25 m)

Fieldbus interfaces

Integrated:



Optional:



Optional:



Integrated safety functions

- The motor controller CMMP-AS supports the "Safe Torque Off (STO)" safety function and, by providing a reliable time delay, also supports "Safe Stop 1 (SS1)" with protection against unexpected start-up in accordance with EN 61800-5-2
- Protection against unexpected start-up
- Two-channel disconnection of the output stage
- Less external circuitry
- Shorter response times in the event of an error
- Faster restart, intermediate circuit remains charged

Motion control

- Evaluation of digital absolute encoder (EnDat/HIPERFACE) in single-turn or multi-turn versions
- Can be operated as a torque, speed or position controller
- Integrated position controller
- Time-optimised (trapezoidal) or jerk-free (S-shaped) positioning
- Absolute and relative movements
- Point-to-point positioning with and without motion path smoothing
- Position synchronisation
- Electronic gear unit
- 255 positioning records
- Wide range of homing methods

Input/output

- Freely programmable I/Os
- High-resolution 16-bit analogue input
- Jog/teach mode
- Simple connection to a higher-order controller via I/O or fieldbus
- Synchronous operation
- Master/slave mode
- Additional I/Os with the plug-in card CAMC-D-8E8A → 459

Integrated sequence control

- Automatic sequence of positioning records without a higher-order controller
- Linear and cyclical position sequences
- Adjustable delay times
- Branches and wait positions
- Overlapping restart possible during the movement

Interpolating multi-axis movement

- With a suitable controller, the CMMP-AS can perform path movements with interpolation via CANopen or Sercos. The controller specifies setpoint position values in a fixed time

pattern to this end. In between, the servo position controller independently interpolates the data values between two data points.

Features

Travel program

- Linking of any number of position sets into a travel program
- Step criteria for the travel program possible via digital inputs, for example
MC – motion complete
I/O – digital inputs

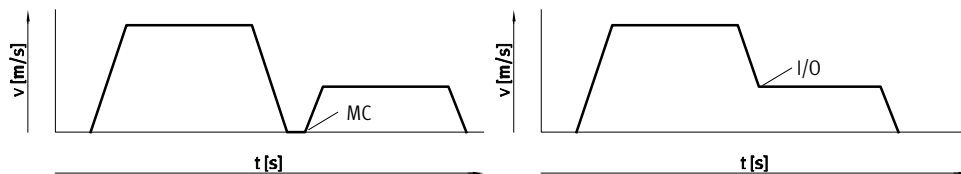

Library for EPLAN



EPLAN macros for fast and reliable planning of electrical projects in combination with motor controllers,

motors and cables. This enables a high level of planning reliability, standardisation of

documentation, no need to create symbols, graphics and master data.

Cam disc functionality

The "electronic cam disc" application type creates optimised motion profiles that generate less vibration and acceleration force at the machine. In addition, the motion of the motor is always synchronous in position with a master axis, which enables easy definition of overlapping, time-optimised motion sequences.

To be able to use the cam disc function, you will need the Festo Configuration Tool (FCT) and also the curve editor
→ online: cmmpp.

Key features:

- High flexibility of the system. The mechanism does not need to be modified if the requirements for the curve shapes change.
- User-friendly motion plan editor. All limits for position, speed and acceleration are immediately displayed in the editor.
- Up to 16 cam discs with a total of up to 2,048 data points can be managed. The data points can be randomly distributed along the cam discs.
- There are four digital trip cams coupled with each cam disc.
- Each cam disc can be offset by a certain amount from the master axis.

System overview

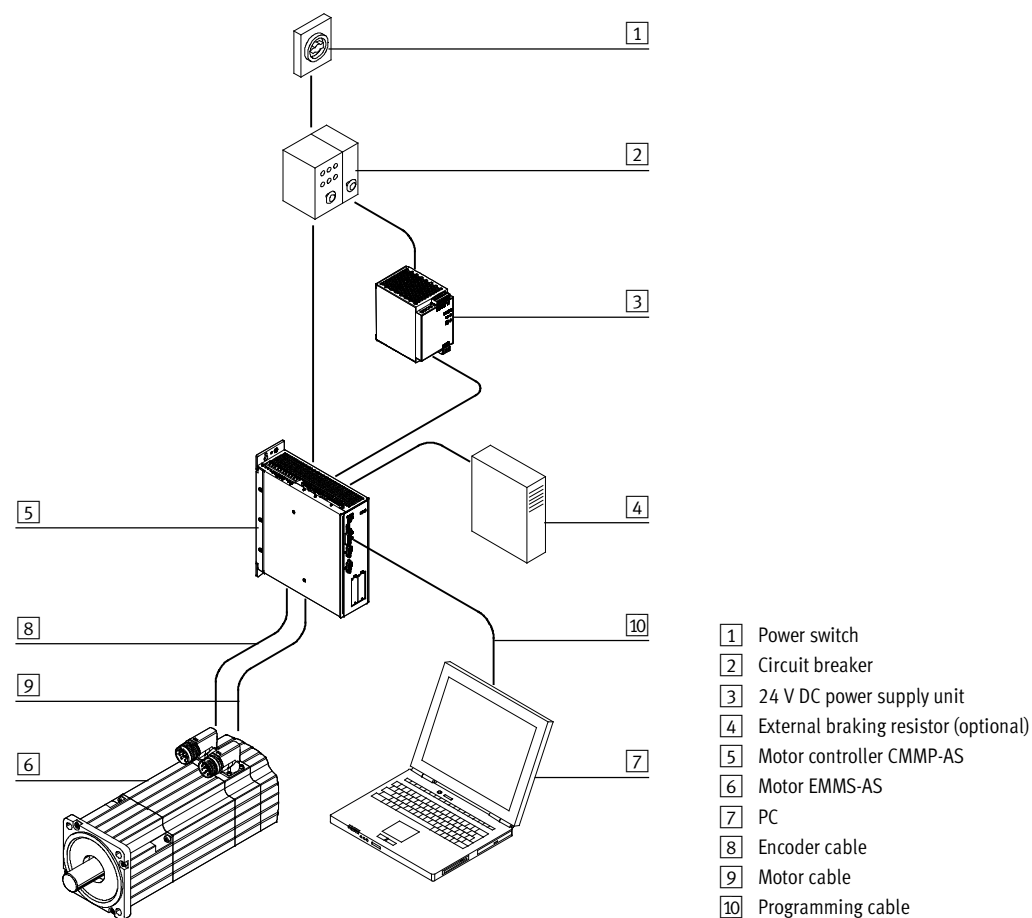

Motor controllers CMMP-AS, for servo motors

FESTO

Technical data

Fieldbus interfaces

CANopen

PROFIBUS

DeviceNet

EtherCAT

PROFINET

EtherNet/IP



4

Technical data		Download CAD data → www.festo.com				
CMMP-AS-		C2-3A-...	C5-3A-...	C5-11A-P3-...	C10-11A-P3-...	C20-11A-P3
Parameterisation interface		USB, Ethernet				RS232
Active PFC		Yes	-			
Encoder interface input		Resolver				
		Incremental encoder with analogue or digital tracking signals				
		Absolute encoder with EnDat V2.1 serial/V2.2				
		Absolute encoder with HIPERFACE				
		Additional input for synchronous/cam disc operation				
Encoder interface output		Actual value feedback via encoder signals in speed control mode				
		Setpoint specification for downstream slave drive				
		Resolution up to 16,384 ppr				
Braking resistor, integrated	[Ω]	60		68		47
Pulse power of braking resistor	[kVA]	2.8		8.5		12
Number of analogue outputs		2				
Operating range of analogue outputs	[V]	±10				
Resolution of analogue outputs		9 bits				
Number of analogue inputs		3				
Operating range of analogue inputs	[V]	±10				
Mains filter		Integrated				
Safety function		Optional → 459				Integrated

Electrical data						
CMMP-AS-		C2-3A-...	C5-3A-...	C5-11A-P3-...	C10-11A-P3-...	C20-11A-P3
Load supply						
Input voltage range	[V AC]	100 ... 230 ±10%		3x 230 ... 480 ±10%		
Max. nominal input current	[A]	3	6	5.5	11	20
Rated output	[VA]	500	1,000	3,000	6,000	12,000
Peak power	[VA]	1,000	2,000	6,000	12,000	25,000
Mains frequency	[Hz]	50 ... 60				
Logic supply						
Nominal voltage	[V DC]	24 ±20%				
Nominal current	[A]	0.55/2.05 ¹⁾	0.65/2.15 ¹⁾	1/3.5 ¹⁾		

1) Max. current with brake and I/Os.

Operating conditions						
CMMP-AS-		C2-3A-...	C5-3A-...	C5-11A-P3-...	C10-11A-P3-...	C20-11A-P3
Ambient temperature	[°C]	0 ... +40				
Protection class		IP20				
Certificate issuing authority		TÜV 01/205/5165/11				DGUV MFS 10027
Safety function		Safe Torque Off (STO)				
Safety integrity level (SIL)		SIL 3/SILCL 3				SIL 2
Performance Level (PL)		Safe Torque Off (STO)/category 4, Performance Level e				Safe Torque off (STO)/Category 3, Performance Level d

Technical data

Technical data – Fieldbus interface		I/O	CANopen	PROFIBUS DP	DeviceNet	EtherCAT	EtherNet/IP	PROFINET RT
Interfaces								
Number of digital logic outputs		5						
Characteristics of digital logic outputs		Freely configurable						
Number of digital logic inputs		10						
Operating range of logic inputs [V]		8 ... 30						
Characteristics of logic inputs		Freely configurable						
Process coupling		16 positioning records	–					
		255 positioning records ¹⁾	250 positioning records					
Communication profile		–	DS301, FHPP+ DS301, DSP402	DP-VO/FHPP+	FHPP+	DS301, FHPP+ CoE: DS301, DSP402	FHPP+	FHPP+
Max. fieldbus transmission rate [Mbps]		–	1	12	0.5	100	100	100
Interface		Integrated	■	■	–	–	–	–
		Optional	–	–	■ → 458	■ → 458	■ → 458	■ → 458

1) With additional I/O plug-in card CAMC-D8E8A → 459.

Order code

		CMMP	–	AS	–		–		–		–	
Type		CMMP	Motor controller, premium									
Motor technology		AS	AC synchronous									
Nominal current		C2	2.5 A									
		C5	5 A									
		C10	10 A									
		C20	20 A									
Input voltage		3A	100 ... 230 V AC [1]									
		11A	3x 230 ... 480 V AC [2]									
Number of phases		–	1-phase [3]									
		P3	3-phase [4]									
Number of slots		–	With 2 slots [5]									
		M3	With 3 slots [6]									

[1] Not with nominal current C10, C20.

[2] Not with nominal current C2.

[3] Not with input voltage 400 V AC.

[4] Not with input voltage 230 V AC.

[5] Only with nominal current C20.

[6] Not with nominal current C20.

Ordering – Product options

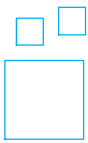

Configurable product

This product and all its options can be ordered using the configurator.

The configurator can be found under Products on the DVD or

→ www.festo.com/catalogue/...

Enter the type code in the search field.

★ Quick ordering

	Description	Part No.	Type
	A plug-in card in slot 1 → 459 is mandatory for operation. Possible plug-in cards: <ul style="list-style-type: none"> • Safety module CAMC-G-S1 • Switch module CAMC-DS-M1 The plug assortment NEKM (→ 458) is included in the scope of delivery of the motor controller.	1501325	CMMP-AS-C2-3A-M3
		1501326	CMMP-AS-C5-3A-M3
		1501327	CMMP-AS-C5-11A-P3-M3
		1501328	CMMP-AS-C10-11A-P3-M3

Accessories – Ordering data

	Part No.	Type
Cable and plug		
Control cable, for I/O interface to any controller		
	552254	NEBC-S1G25-K-2.5N-LE26
Programming cable		
	For CMMP-AS-C2/C5/C10-M3	
	1501332	NEBC-U1G-K-1.8-N-U2G
	For CMMP-AS-C20-11A-P3	
	160786	PS1-ZK11-NULLMODEM-1,5M
Encoder plug		
	564264	NECC-A-S-S1G9-C2M
Plug assortment		
	For CMMP-AS-C2-3A-M3, CMMP-AS-C5-3A-M3	
	1659228	NEKM-C-7 ¹⁾
	For CMMP-AS-C5-11A-P3-M3, CMMP-AS-C10-11A-P3-M3	
	552256	NEKM-C-3 ¹⁾
	For CMMP-AS-C20-11A-P3	
	1425453	NEKM-C-6 ²⁾
	For interface CAMC-D-8E8A	
	569959	NEKM-C-5 ³⁾
For safety module CAMC-G-S1		
1660640	NEKM-C-8 ⁴⁾	

	Part No.	Type
Cable and plug		
Plug		
	For PROFIBUS interface	
	533780	FBS-SUB-9-WS-PB-K
	For CANopen interface	
	533783	FBS-SUB-9-WS-CO-K
Plug, for DeviceNet interface		
	525635	FBSD-KL-2X5POL
Plug-in card		
	For PROFIBUS interface	
	★ 547450	CAMC-PB
	For DeviceNet interface	
	★ 547451	CAMC-DN
	For EtherCAT interface	
	★ 567856	CAMC-EC
	For EtherNet/IP interface	
	★ 1911917	CAMC-F-EP
For PROFINET RT interface		
★ 1911916	CAMC-F-PN	

1) Plugs are included in the scope of delivery of the motor controller CMMP-AS-...-M3.

2) Plugs are included in the scope of delivery of the motor controller CMMP-AS-C20-11A-P3.



3) Plugs are included in the scope of delivery of the plug-in card CAMC-D-8E8A.

4) Plug is included in the scope of delivery of the plug-in card CAMC-G-S1.

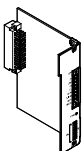
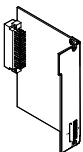
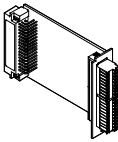
Accessories – Ordering data

	Part No.	Type
Plug-in card¹⁾		
Safety module		
	★ 1501330	CAMC-G-S1
Switch module		
	★ 1501329	CAMC-DS-M1
Interface, for extending the digital I/Os ²⁾		
	★ 567855	CAMC-D-8E8A

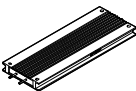
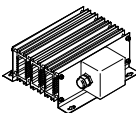
- 1) The plugs are included in the scope of delivery.
- 2) 8 digital input/outputs.

	Part No.	Type
Braking resistor		
	For CMMP-AS-C2-3A, CMMP-AS-C5-3A	
	1336615	CACR-LE2-100-W500
	For CMMP-AS-C5-11A-P3, CMMP-AS-C10-11A-P3	
	1336617	CACR-KL2-67-W1800
	For CMMP-AS-C20-11A-P3	
	1336619	CACR-KL2-33-W2400
Type		
Documentation and software		
	Ordering data → online: cmmmp	

4

Note

Operation of the motor controller CMMP-AS-...-M3 absolutely requires that a plug-in card (CAMC-G-S1 or CAMC-DS-M1) be inserted in slot **1**.

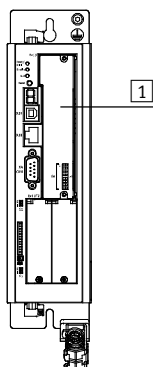

Motor controllers CMMO-ST, for stepper motors

FESTO

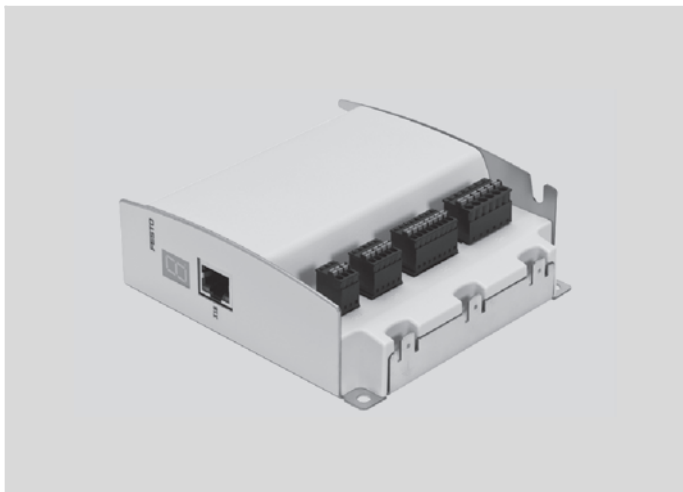

- Position controller for electric cylinder EPCO
- Closed-loop encoder option, therefore no step losses
- Monitoring of freely definable position zones
- Easy actuation via I/O interfaces
- Easy configuration with free FCT software
- ★ Quick ordering of basic designs → 461

→ www.festo.com/catalogue/cmmo-st

Product range overview

Type	Nominal voltage [V DC]	Nominal current [A]	Interfaces I/O interface
CMMO-ST	24 ±15%	6	■

Technical data

Technical data		Download CAD data → www.festo.com
Process coupling	I/O coupling for 32 positioning records	
Operating mode, open-loop control	Micro step, 12,800 steps/revolution	
Operating mode, closed-loop control	Sinusoidal current control, within the cascade controller	
Number of digital logic inputs	11	
Number of digital logic outputs	11	
Parameterisation interface	Ethernet	
Ethernet, supported protocols	TCP/IP	
Encoder interface input	RS422	

Electrical data

Load supply		
Nominal voltage	[V DC]	24 ±15%
Nominal current	[A]	6
Peak current	[A]	8
Logic supply		
Nominal voltage	[V DC]	24 ±15%
Nominal current	[A]	0.3
Max. current per output	[mA]	100

Operating conditions

Ambient temperature	[°C]	0 ... +50
Protection class	IP40	
Safety function	Safe Torque Off (STO)	
Safety integrity level (SIL)	SIL 3	
Performance Level (PL)	Safe Torque Off (STO)/category 3, Performance Level e	

Ordering – Product options

Configurable product

This product and all its options can be ordered using the configurator.

The configurator can be found under Products on the DVD or
www.festo.com/catalogue/...

Enter the type code in the search field.

★ Quick ordering

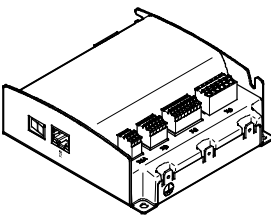
	Description	Part No.	Type
	With I/O interface		
	Switching input/output PNP	1512316	CMMO-ST-C5-1-DIOP
	Switching input/output NPN	1512317	CMMO-ST-C5-1-DION

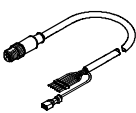
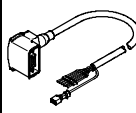
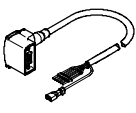
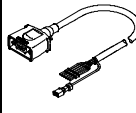
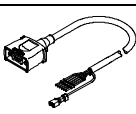

Accessories – Ordering data

	Cable length	Part No.	Type		Cable length	Part No.	Type		
Motor cable for EPCO-16; EMMS-ST-28				Motor cable for EMMS-ST-87					
	Straight plug				Angled plug				
	1.5 m	★	1449600		NEBM-M12G8-E-1.5-Q5-LE6	1.5 m	★	1450943	NEBM-S1W15-E-1.5-Q7-LE6
	2.5 m	★	1449601		NEBM-M12G8-E-2.5-Q5-LE6	2.5 m	★	1450944	NEBM-S1W15-E-2.5-Q7-LE6
	5 m	★	1449602		NEBM-M12G8-E-5-Q5-LE6	5 m	★	1450945	NEBM-S1W15-E-5-Q7-LE6
	7 m	★	1449603		NEBM-M12G8-E-7-Q5-LE6	7 m	★	1450946	NEBM-S1W15-E-7-Q7-LE6
	10 m	★	1449604		NEBM-M12G8-E-10-Q5-LE6	10 m	★	1450947	NEBM-S1W15-E-10-Q7-LE6
Motor cable for EPCO-25/-40; EMMS-ST-42/-57									
	Angled plug				Straight plug				
	1.5 m	★	1450736		NEBM-S1W9-E-1.5-Q5-LE6	1.5 m		1450834	NEBM-S1G15-E-1.5-Q7-LE6
	2.5 m	★	1450737		NEBM-S1W9-E-2.5-Q5-LE6	2.5 m		1450835	NEBM-S1G15-E-2.5-Q7-LE6
	5 m	★	1450738		NEBM-S1W9-E-5-Q5-LE6	5 m		1450836	NEBM-S1G15-E-5-Q7-LE6
	7 m	★	1450739		NEBM-S1W9-E-7-Q5-LE6	7 m		1450837	NEBM-S1G15-E-7-Q7-LE6
	10 m	★	1450740		NEBM-S1W9-E-10-Q5-LE6	10 m		1450838	NEBM-S1G15-E-10-Q7-LE6
	Straight plug								
	1.5 m		1450368	NEBM-S1G9-E-1.5-Q5-LE6					
	2.5 m		1450369	NEBM-S1G9-E-2.5-Q5-LE6					
	5 m		1450370	NEBM-S1G9-E-5-Q5-LE6					
	7 m		1450371	NEBM-S1G9-E-7-Q5-LE6					
	10 m		1450372	NEBM-S1G9-E-10-Q5-LE6					

Motor controllers CMMO-ST, for stepper motors

FESTO

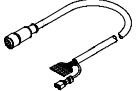
Accessories – Ordering data

	Cable length	Part No.	Type
Encoder cable for EPCO-16/-25/-40; EMMS-ST-28/-42/-57/-87			
	Straight plug		
	1.5 m	★ 1451586	NEBM-M12G8-E-1.5-LE8
	2.5 m	★ 1451587	NEBM-M12G8-E-2.5-LE8
	5 m	★ 1451588	NEBM-M12G8-E-5-LE8
	7 m	★ 1451589	NEBM-M12G8-E-7-LE8
	10 m	★ 1451590	NEBM-M12G8-E-10-LE8
Encoder cable for EPCO-25/-40; EMMS-ST-42/-57/-87			
	Angled plug		
	1.5 m	★ 1451674	NEBM-M12W8-E-1.5-LE8
	2.5 m	★ 1451675	NEBM-M12W8-E-2.5-LE8
	5 m	★ 1451676	NEBM-M12W8-E-5-LE8
	7 m	★ 1451677	NEBM-M12W8-E-7-LE8
	10 m	★ 1451678	NEBM-M12W8-E-10-LE8

	Part No.	Type
Plug assortment		
	★ 576005	NEKM-C-10 ¹⁾

1) Plug for motor cable, encoder cable, power supply, reference switch, STO safety function. Plugs are included in the scope of delivery of the motor controller.

4

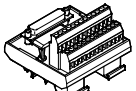
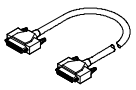
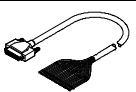
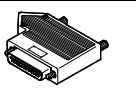
Connection options from I/O interface to controller		Part No.	Type
Connection block			
	Ensures simple and clear wiring. The connection to the motor controller is established via the connecting cable NEBC-S1G25-K-...	8001371	NEFC-S1G25-C2W25-S7
Connecting cable			
	Connects the motor controller to the connection block	8001374	NEBC-S1G25-K-1.0-N-S1G25
		8001375	NEBC-S1G25-K-2.0-N-S1G25
		8001376	NEBC-S1G25-K-5.0-N-S1G25
Control cable			
	Is connected to the motor controller. The other end comprises individual flying leads	★ 8001373	NEBC-S1G25-K-3.2-N-LE25
Plug			
	25-pin sub-D plug. Each wire can be individually assembled using screw terminals	★ 8001372	NEFC-S1G25-C2W25-S6



- Open-loop operation, optional closed-loop operation with encoder
- Integrated SD card slot
- Compatible with motor EMMS-ST
- Easy configuration with free FCT software
- ★ Quick ordering of basic designs → 466

→ www.festo.com/catalogue/cmms-st

Product range overview

Type	Nominal voltage Load [V DC]	Nominal voltage Logic [V DC]	Interfaces			
			I/O interface	CANopen	PROFIBUS	DeviceNet
CMMS-ST-C8-7-G2	24 ... 48	24	■	■	■	■

Features

Compactness

- Small dimensions
- Full integration of all components for the controller and power section, including RS232 and CANopen interface
- Integrated brake chopper
- Integrated EMC filters

- Automatic actuation for a holding brake
- Complies with the current CE and EN standards without additional external measures (motor cable length of up to 15 m)

Motion control

- Can be operated as a torque, speed or position controller
- Integrated position controller
- Time-optimised (trapezoidal) or jerk-free (S-shaped) positioning
- Absolute and relative movements
- Point-to-point positioning with and without motion path smoothing

- Position synchronisation
- Electronic gear unit
- 63 positioning records
- 8 positioning profiles
- Wide range of homing methods

Fieldbus interfaces

Integrated:

CANopen

Optional:

PROFI
PROCESS FIELD BUS

DeviceNet
CONNECTION NETWORK

Input/output

- Freely programmable I/Os
- High-resolution 12-bit analogue input
- Jog/teach mode
- Simple connection to a higher-order controller via I/O or fieldbus
- Synchronous operation
- Master/slave mode

Integrated sequence control

- Automatic sequence of positioning records without a higher-order controller
- Linear and cyclical position sequences
- Adjustable delay times

Safety functions

- The position controller CMMS-ST supports the "Safe Torque Off (STO)" and "Safe Stop 1 (SS1)" safety functions with protection against unexpected start-up in accordance with the requirements of EN 61800-5-2

- Protection against unexpected start-up
- Two-channel disconnection of the output stage
- Shorter response times in the event of an error

Interpolating multi-axis movement

- With a suitable controller, the CMMS-ST can perform path movements with interpolation via CANopen. The controller specifies setpoint position values in a fixed time pattern

to this end. In between, the servo position controller independently interpolates the data values between two data points.

Servo mode

- Encoder option (closed loop), in other words no step losses, following errors are corrected

Motor controllers CMMS-ST, for stepper motors

Features

Travel program

- Linking of any number of position sets into a travel program
- Step criteria for the travel program possible via digital inputs, for example
 MC – motion complete
 I/O – digital inputs

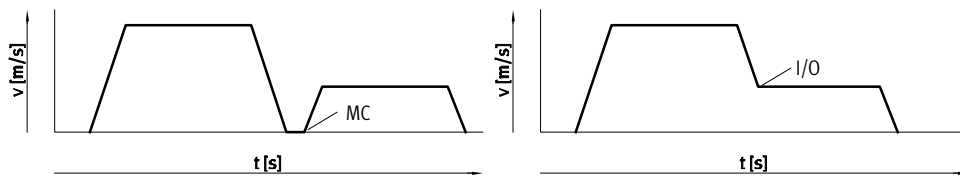

Library for EPLAN



EPLAN macros for fast and reliable planning of electrical projects in combination with motor controllers,

motors and cables. This enables a high level of planning reliability, standardisation of

documentation, no need to create symbols, graphics and master data.

System overview

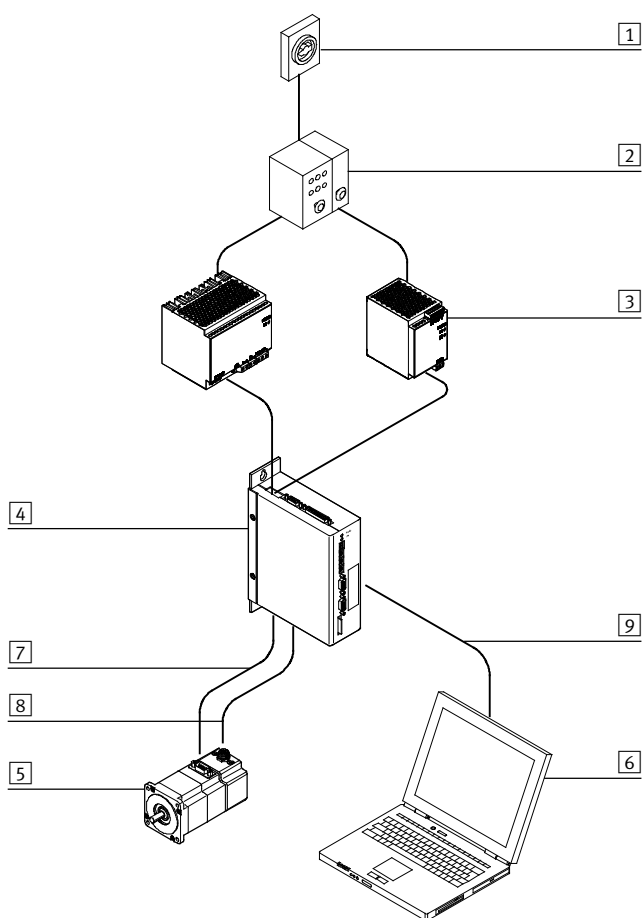

- 1 Power switch
- 2 Circuit breaker
- 3 24 V DC power supply unit
- 4 Motor controller CMMS-ST
- 5 Motor EMMS-ST
- 6 PC
- 7 Motor cable
- 8 Encoder cable
- 9 Programming cable

Technical data

Fieldbus interfaces

CANopen

PROFI
PROFIBUS DP

DeviceNet
CONFORMANCE TESTED



4

Technical data		Download CAD data → www.festo.com
Motor activation	Sinusoidal current impressing	
Rotary position encoder	Encoder	
Parameterisation interface	RS232 (9,600 ... 115,000 bits/s)	
Encoder interface input	As speed/position specification for the slave drive in synchronous mode	
	RS422	
Encoder interface output	Setpoint specification for downstream slave drive	
Braking resistor, integrated	[Ω]	17
Pulse power of braking resistor	[kVA]	0.5
Impedance of setpoint input	[kΩ]	20
Number of analogue outputs	1	
Operating range of analogue outputs	[V]	±10
Number of analogue inputs	1	
Operating range of analogue inputs	[V]	±10
Mains filter	Integrated	

Electrical data		
Load supply		
Nominal voltage	[V DC]	24 ... 48
Nominal current	[A]	8
Peak current	[A]	12
Logic supply		
Nominal voltage	[V DC]	24 ±20%
Nominal current	[A]	0.3

Operating conditions		
Ambient temperature	[°C]	0 ... +50
Protection class	IP20	
Certificate issuing authority	BG MFS 09031	
Safety function	Safe Torque Off (STO)	
Safety integrity level (SIL)	SIL 2	
Performance Level (PL)	Safe Torque Off (STO)/category 3, Performance Level d	

Technical data – Fieldbus interface					
Interfaces		I/O	CANopen	PROFIBUS DP	DeviceNet
Communication profile		–	DS301, FHPP	DP-V0/FHPP	FHPP
		–	DS301, DSP402	–	
Max. fieldbus transmission rate	[Mbps]	–	1	12	0.5
Interface	Integrated	■	■	–	–
	Optional	–	–	■ → 466	■ → 466

Motor controllers CMMS-ST, for stepper motors

Ordering – Product options



Configurable product

This product and all its options can be ordered using the configurator.

The configurator can be found under Products on the DVD or
www.festo.com/catalogue/...

Enter the type code in the search field.

★ Quick ordering

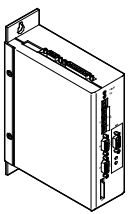
	Description	Part No.	Type
4	 <p>The plug assortment NEKM (→ 466) is included in the scope of delivery of the motor controller.</p>	572211	CMMS-ST-C8-7-G2

Accessories – Ordering data

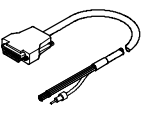
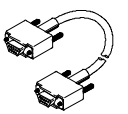
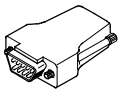
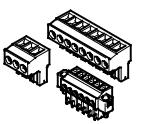
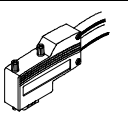
	Part No.	Type
Cable and plug		
Control cable, for I/O interface to any controller		
	552254	NEBC-S1G25-K-2.5N-LE26
Programming cable		
	160786	PS1-ZK11-NULLMODEM-1,5M
Encoder plug		
	564264	NECC-A-S-S1G9-C2M
Plug assortment		
	547452	NEKM-C-1
Plug		
	For PROFIBUS interface	
	533780	FBS-SUB-9-WS-PB-K
	For CANopen interface	
	533783	FBS-SUB-9-WS-CO-K

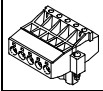
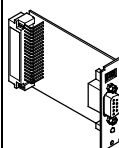
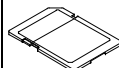
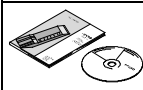
	Part No.	Type
Cable and plug		
Plug, for DeviceNet interface		
	525635	FBSD-KL-2X5POL
Plug-in card		
	Interface, for PROFIBUS interface	
	★ 547450	CAMC-PB
	Interface, for DeviceNet interface	
★ 547451	CAMC-DN	
Memory card for data backup and firmware download		
	1436343	CAMC-M-S-F10-V1
	Type	
Documentation and software		
	Ordering data → online: cmms	

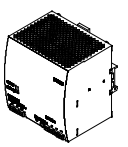
	Nominal output voltage [V DC]	Nominal output current [A]	Part No.	Type
Power supply unit				
Technical data online: → svg				
	24	5	547867	SVG-1/230VAC-24VDC-5A
		10	547868	SVG-1/230VAC-24VDC-10A
	48	5	542403	SVG-1/230VAC-48VDC-5A
		10	542404	SVG-1/230VAC-48VDC-10A
		20	542405	SVG-3/400VAC-48VDC-20A

Note

If a common power supply unit is used to supply the power section and the control section, the voltage tolerances for the supply to the control section cannot be maintained at high braking power. This can result in damage to the control section. Always use separate power supply units to supply the power section and the control section.



- Monitoring of safety command devices (emergency stop switches, safety door switches, light curtains, etc.)
- Reliable speed and positioning functions possible
- Reliable stop functions
- Encoder signals can be evaluated
- Freely programmable, therefore very flexible
- Ready-to-use program examples available

→ www.festo.com/catalogue/cmga

Product range overview

Type	Performance Level (PL)	Safety integrity level (SIL)	Number of encoder interfaces			Communication				
			0	1	2	I/O interface	CANopen	DeviceNet	PROFIBUS	
Basic modules										
CMGA-B1-M0-L0-A0	Cat. 4, PL e	SIL 3	■	-	-	-	-	-	-	
CMGA-B1-M1-L1-A0			-	■	-	-	-	-	-	
CMGA-B1-M2-L2-A0			-	-	■	-	-	-	-	
Extension modules										
CMGA-E1	Cat. 4, PL e	SIL 3	-	-	-	■	-	-	-	
CMGA-E1-CO			-	-	-	-	■	-	-	
CMGA-E1-DN			-	-	-	-	-	-	■	-
CMGA-E1-PB			-	-	-	-	-	-	-	■

At a glance

Basic modules

- CMGA-B1-M0-L0-A0
- CMGA-B1-M1-L1-A0
- CMGA-B1-M2-L2-A0

The CMGA is a compact safety system with the option of integrated drive monitoring for one axis. It can be parameterised using downloadable application programs (→ www.festo.com/net/SupportPortal). An ideal solution for simple applications. The safety system can also be freely programmed for implementing complex applications.

Suitable for safe processing of:

- Emergency stop switches
- Door monitoring
- Light curtains
- Two-hand buttons
- Enabling buttons
- Limit switches
- Measuring systems

There are pre-configured modules available for pre-processing of safety-relevant signals. The same applies to safety functions for drive monitoring.

In its basic design, the device has 14 safe inputs and 3 switch-off channels, which can be extended to max. 65 safe I/Os.

There are modules with encoder interface (incl. TTL/HTL, SIN/COS, proximity switch) available for safe speed and/or position sensing.

Extension modules

- CMGA-E1
- CMGA-E1-CO
- CMGA-E1-DN
- CMGA-E1-PB

Extension modules for I/O:
The extension module has:

- 12 safe inputs
- 10 safe inputs/outputs, can be configured as inputs or outputs
- 2 signal outputs

Extension modules for fieldbus:
Extension modules for transmitting diagnostic and status data to a higher-order controller by means of a standard fieldbus.

A maximum of two extension modules can be operated with one basic module.

Safety systems CMGA

FESTO

Technical data – Basic modules



4

Technical data

Download CAD data → www.festo.com

Type	CMGA-		
	B1-M0-L0-A0	B1-M1-L1-A0	B1-M2-L2-A0
Axis monitoring	–	1 axis	1 axis
Encoder interface input, function	–	1 input: incr. TTL (max. 200 kHz) incr. HTL (max. 200 kHz) sin/cos (max. 200 kHz) SSI (max. 150 kHz)	2 inputs: incr. TTL (max. 200 kHz) incr. HTL (max. 200 kHz) sin/cos (max. 200 kHz) SSI (max. 150 kHz)
	–	1 input: Proximity sensor (max. 10 kHz)	2 inputs: Proximity sensor (max. 10 kHz)
Number of digital logic inputs	14, including 8 OSSD-compatible (24 V DC/20 mA)		
Digital output design	1 safe relay output (24 V DC/2 A or 230 V AC/2 A)		
	2 signal outputs (24 V DC/100 mA)		
	2 pulse outputs (max. 250 mA)		
	2 safe digital outputs (24 V DC/250 mA)		

Safety characteristics

Type	CMGA-		
	B1-M0-L0-A0	B1-M1-L1-A0	B1-M2-L2-A0
Conforms to standard	EN ISO 13849-1		
Safety function	Safe Torque Off (STO)		
	Safe Brake Control (SBC)		
	Safe logic functions		
	Safe Stop 1 (SS1), type 3		
	–	Safe Stop 1 (SS1), type 1, 2	
	–	Safe Operating Stop (SOS)	
	–	Safe Stop 2 (SS2), type 1, 2, 3	
	–	Safely Limited Speed (SLS)	
	–	Safely Limited Position (SLP)	
	–	Safe Direction (SDI)	
	–	Safely Limited Increment (SLI)	
	–	Safely Limited Acceleration (SLA)	
	–	Safe Emergency Limit (SEL)	
–	Safe Cam (SCA)		
–	Position Deviation Muting (PDM)		
–	Encoder Status (ECS)		
Performance Level (PL)	Category 4, Performance Level e		
Safety integrity level (SIL)	SIL 3		
Certificate issuing authority	TÜV Rheinland		
PFH	3.0 x 10 ⁻⁹	2.2 x 10 ⁻⁹	6.2 x 10 ⁻⁹
Proof test interval	20 a		
CE marking (see declaration of conformity)	To EU EMC Directive ¹⁾		
	To EU Machinery Directive		
Shock resistance	As per EN 60068-2-29		
Vibration resistance	As per EN 60068-2-6		

1) For information about the applicability of the component see the manufacturer's EC declaration of conformity at: www.festo.com → Support → User documentation.
If the component is subject to usage restrictions in residential, office or commercial locations or small businesses, further measures for the reduction of the emitted interference may be necessary.

Technical data – Basic modules

Electrical data		
Nominal operating voltage	[V DC]	24 (-15%/+20%)
Nominal current, logic supply	[A]	Max. 2
Operating range of logic input	[V DC]	24 (-15%/+20%)
Logic input specification		Based on IEC 61131-2
Safe digital outputs	[mA]	250
Signal outputs	[mA]	100

Operating conditions		
Ambient temperature	[°C]	0 ... +50
Protection class		IP20

4

Order code – Basic modules

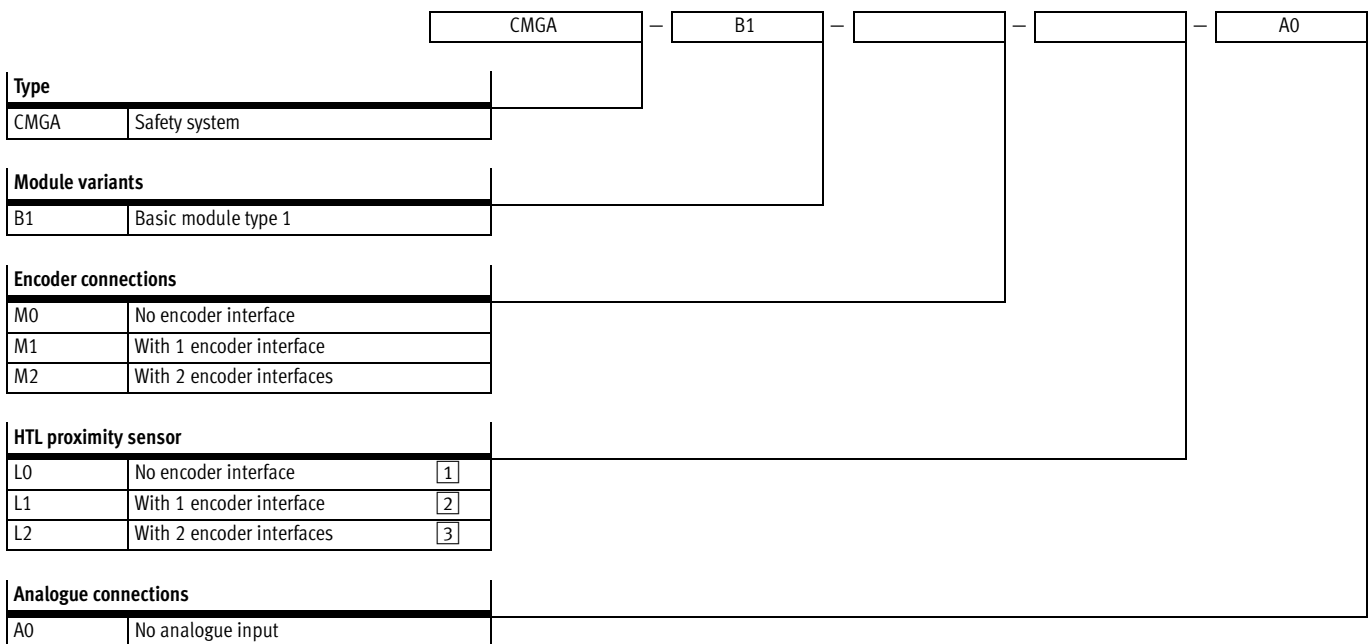

- 1 Only with encoder connection M0.
- 2 Only with encoder connection M1.
- 3 Only with encoder connection M2.

Ordering – Product options

Configurable product

This product and all its options can be ordered using the configurator.

The configurator can be found under Products on the DVD or
[→ www.festo.com/catalogue/...](http://www.festo.com/catalogue/...)

Enter the type code in the search field.

Safety systems CMGA

FESTO

Technical data – Extension modules

Fieldbus interfaces

CANopen

DeviceNet

PROFI[®]
BUS

4

Technical data

Download CAD data → www.festo.com

Type	CMGA-			
	E1	E1-CO	E1-DN	E1-PB
Number of digital logic inputs	12, including 8 OSSD-compatible	–	–	–
Digital output design	10 safe digital inputs/ outputs	–	–	–
	2 signal outputs	–	–	–
	2 pulse outputs	–	–	–

Safety characteristics

Type	CMGA-			
	E1	E1-CO	E1-DN	E1-PB
Conforms to standard	EN ISO 13849-1			
Performance Level (PL)	Cat. 4, PL e			
Safety integrity level (SIL)	SIL 3			
Certificate issuing authority	TÜV Rheinland			
PFH	2.6×10^{-9}			
Proof test interval	20 a			
CE marking (see declaration of conformity)	To EU EMC Directive ¹⁾			
	To EU Machinery Directive			
Shock resistance	As per EN 60068-2-29			
Vibration resistance	As per EN 60068-2-6			

- 1) For information about the applicability of the component see the manufacturer's EC declaration of conformity at: www.festo.com → Support → User documentation.
If the component is subject to usage restrictions in residential, office or commercial locations or small businesses, further measures for the reduction of the emitted interference may be necessary.

Electrical data

Type	CMGA-			
	E1	E1-CO	E1-DN	E1-PB
Nominal operating voltage [V DC]	24 (–15%/+20%)			
Nominal current, logic supply [A]	2	–	–	–
Operating range of logic input [V DC]	24 (–15%/+20%)			
Logic input specification	Based on IEC 61131-2			
Safe digital inputs/outputs [mA]	250			
Signal outputs [mA]	100			

Technical data – Extension modules

Technical data – Fieldbus interface		CMGA-			
Type		E1	E1-CO	E1-DN	E1-PB
Bus connection		–	9-pin, Sub-D	5-pin, Sub-D	9-pin, Sub-D
Fieldbus coupling		–	CANopen	DeviceNet	PROFIBUS DP
Max. fieldbus transmission rate	[Mbps]	–	1	0.5	12

Operating conditions	
Ambient temperature	[°C] 0 ... +50
Protection class	IP20

Order code – Extension modules

		CMGA	–	E1	–	
Type						
CMGA	Extension module					
Module variants						
E1	Extension module for series CMGA-B1					
Communication						
–	I/O					
CO	CANopen					
DN	DeviceNet					
PB	PROFIBUS DP					

Ordering – Product options

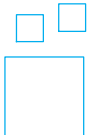

Configurable product

This product and all its options can be ordered using the configurator.

The configurator can be found under Products on the DVD or
[→ www.festo.com/catalogue/...](http://www.festo.com/catalogue/...)

Enter the type code in the search field.

Accessories – Ordering data

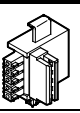
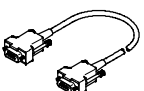
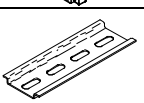
	Description	Part No.	Type
	Plug connector for connecting the modules to one another via a rear wall bus	1680832	NEKM-C-13
	Encoder cable for connection between safety system CMGA and motor controller CMM...	1680830	NEBC-S1G9-K-0.5-N-S-S1G9
	Programming cable for converting the USB interface on the PC for CMGA modules	1680831	NEBC-S1G9-K-2-N-S-S1G9
	Mounting rail for attaching the safety systems	1680835	NEBC-U1G4-K-2-N-R5G4
		35430	NRH-35-2000

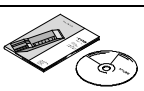
Type
Documentation and software
 Ordering data → online: cmga

Gear units EMGA-SST, for stepper motors

FESTO

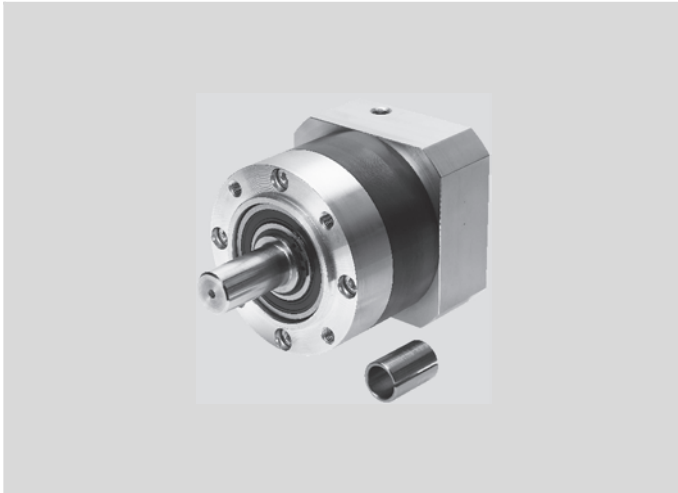

- For force-locked and backlash-free transmission of torques
- Low torsional backlash
- Very smooth running
- Lubricated for life
- Adapted to the Festo range of motors
- ★ Quick ordering of basic designs → 474

→ www.festo.com/catalogue/emga

Product range overview

Flange size	Output torque [Nm]	Gear ratio	
		3	5
40 ... 80	17.6 ... 176	■	■

Technical data

Technical data		Dimensions → 474					
Motor flange size		42		57		87	
Gear unit type		EMGA-40-P-G...		EMGA-60-P-G...		EMGA-80-P-G...	
Gear ratio	[i]	3	5	3	5	3	5
Continuous output torque ¹⁾	[Nm]	11	14	22	22	85	110
Max. output torque	[Nm]	17.6	22	35.2	35.2	136	176
Torsional backlash	[deg]	0.25		0.17		0.12	
Moment of inertia ²⁾	[kgcm ²]	0.031	0.019	0.135	0.078	0.77	0.45
Operating temperature ³⁾	[°C]	-25 ... +90					
Protection class		IP54					

1) At the output shaft.

2) In relation to the drive shaft.

3) Note the temperature range of the motor.

Gear units EMGA-SST, for stepper motors

FESTO

★ Quick ordering

Motor flange size	Part No.	Type
42	549428	EMGA-40-P-G3-SST-42
	549429	EMGA-40-P-G5-SST-42
57	549430	EMGA-60-P-G3-SST-57
	549431	EMGA-60-P-G5-SST-57

Motor flange size	Part No.	Type
87	549432	EMGA-80-P-G3-SST-87
	549433	EMGA-80-P-G5-SST-87

Ordering – Product options



Configurable product

This product and all its options can be ordered using the configurator.

The configurator can be found under Products on the DVD or

→ www.festo.com/catalogue/...

Enter the type code in the search field.

Dimensions

Download CAD data → www.festo.com

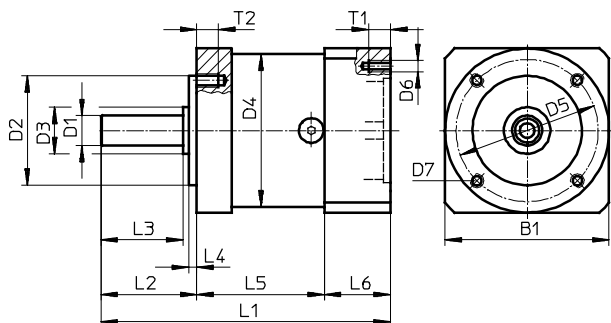

Motor flange size	B1	D1 ∅ h7	D2 ∅ h7	D3 ∅	D4 ∅	D5 ∅	D6	D7
42	40	10	26	12	40	34	∅3.4	M4
57	60	11	40	17	60	52	M4	M5
87	90	20	60	25	80	70	M5	M6

Motor flange size	L1	L2	L3	L4	L5	L6	T1	T2
	±1.5		±0.2	±0.2				
42	92.5	26±0.6	23	2	39	27.5	5	6
57	106	35±0.8	30	3	47	24	8	8
87	135.5	40±0.8	36	3	60	35.5	12	10

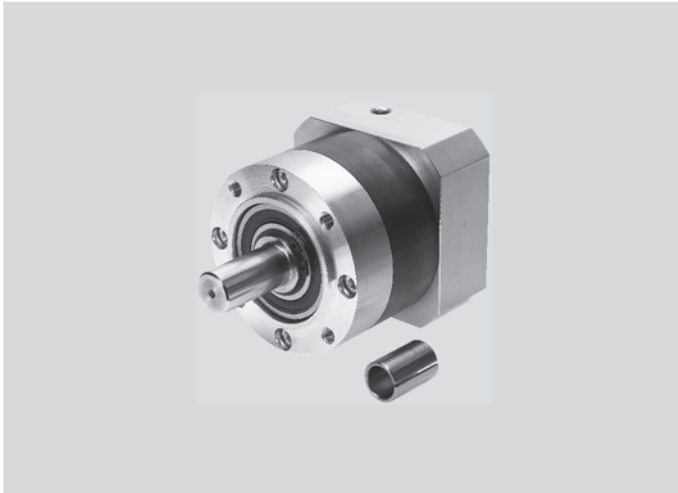

- For force-locked and backlash-free transmission of torques
- Low torsional backlash
- Very smooth running
- Lubricated for life
- Adapted to the Festo range of motors
- ★ Quick ordering of basic designs → 476

→ www.festo.com/catalogue/emga

Product range overview

Flange size	Output torque [Nm]	Gear ratio	
		3	5
40 ... 160	17.6 ... 720	■	■

Technical data

Technical data										Dimensions → 476	
Motor flange size	40			55		70					
Gear unit type	EMGA-40-P-G...-40			EMGA-60-P-G...-55		EMGA-60-P-G...-70		EMGA-80-P-G...-70			
Gear ratio	[i]	3	5	3	5	3	5	3	5		
Continuous output torque ¹⁾	[Nm]	11	14	22	22	22	22	85	110		
Max. output torque ²⁾	[Nm]	17.6	22	35.2	35.2	35.2	35.2	136	176		
Torsional backlash	[deg]	0.25		0.17		0.17		0.12			
Moment of inertia ³⁾	[kgcm ²]	0.031	0.019	0.135	0.078	0.135	0.078	0.77	0.45		
Operating temperature ⁴⁾	[°C]	-25 ... +90									
Protection class		IP54									

Motor flange size	100				140				
Gear unit type	EMGA-80-P-G...-100		EMGA-120-P-G...-100		EMGA-120-P-G...-140		EMGA-160-P-G...-140		
Gear ratio	[i]	3	5	3	5	3	5	3	5
Continuous output torque ¹⁾	[Nm]	85	110	115	195	115	195	400	450
Max. output torque ²⁾	[Nm]	136	176	184	312	184	312	640	720
Torsional backlash	[deg]	0.12		0.12		0.12		0.1	
Moment of inertia ³⁾	[kgcm ²]	0.77	0.45	2.63	1.53	2.63	1.53	12.14	6.07
Operating temperature ⁴⁾	[°C]	-25 ... +90							
Protection class		IP54							

- 1) At the output shaft.
- 2) The specifications refer to an output shaft speed of 100 rpm as well as operating mode S1 and a temperature of 30 °C.
- 3) In relation to the drive shaft.
- 4) Note the temperature range of the motor.

★ Quick ordering

Motor flange size	Part No.	Type
40	552186	EMGA-40-P-G3-SAS-40
	552187	EMGA-40-P-G5-SAS-40
55	552188	EMGA-60-P-G3-SAS-55
	552189	EMGA-60-P-G5-SAS-55
70	552190	EMGA-60-P-G3-SAS-70
	552191	EMGA-60-P-G5-SAS-70
	552192	EMGA-80-P-G3-SAS-70
	552193	EMGA-80-P-G5-SAS-70

Motor flange size	Part No.	Type
100	552194	EMGA-80-P-G3-SAS-100
	552195	EMGA-80-P-G5-SAS-100
	552196	EMGA-120-P-G3-SAS-100
	552197	EMGA-120-P-G5-SAS-100
140	552198	EMGA-120-P-G3-SAS-140
	552199	EMGA-120-P-G5-SAS-140
	552200	EMGA-160-P-G3-SAS-140
	552201	EMGA-160-P-G5-SAS-140

4

Ordering – Product options

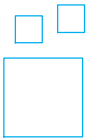

Configurable product

This product and all its options can be ordered using the configurator.

The configurator can be found under Products on the DVD or

→ www.festo.com/catalogue/...

Enter the type code in the search field.

Dimensions

Download CAD data → www.festo.com

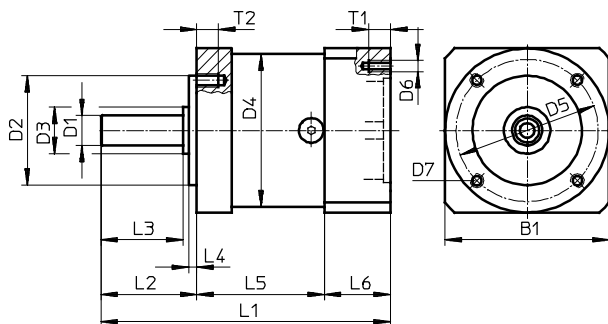

Type	B1	D1 ∅ h7	D2 ∅ h7	D3 ∅	D4 ∅	D5 ∅	D6	D7
EMGA-40-...-40	40	10	26	12	40	34	M3	M4
EMGA-60-...-55	60	11	40	17	60	52	M5	M5
EMGA-60-...-70	70	11	40	17	60	52	M5	M5
EMGA-80-...-70	80	20	60	25	80	70	M5	M6
EMGA-80-...-100	100	20	60	25	80	70	M8	M6
EMGA-120-...-100	115	25	80	35	115	100	M8	M10
EMGA-120-...-140	140	25	80	35	115	100	M10	M10
EMGA-160-...-140	140	40	130	55	160	145	M10	M12

Type	L1	L2	L3 ±0.2	L4 ±0.2	L5	L6	T1	T2
EMGA-40-...-40	88.5±1.5	26±0.6	12	2	39	23.5	6	6
EMGA-60-...-55	106±1.5	35±0.8	30	3	47	24	12	8
EMGA-60-...-70	106±1.5	35±0.8	30	3	47	24	12	8
EMGA-80-...-70	133.5±1.5	40±0.8	36	3	60	33.5	12	10
EMGA-80-...-100	143.5±1.5	40±0.8	36	3	60	43.5	16	10
EMGA-120-...-100	176.5±2	55±0.8	50	4	74	47.5	20	16
EMGA-120-...-140	186±2	55±0.8	50	4	74	57.5	25	16
EMGA-160-...-140	255.5±2	87±0.8	80	5	104	64.5	25	20

5 Grippers



Software tool

Gripper selection





A secure grip is a question of the right calculation. In this case, calculation of weight, direction of movement, distances, etc. The software tool immediately determines which type of gripper – parallel, three-point, angle or swivel/gripper – and which size best matches your requirements.

This tool can be found





- in the electronic catalogue via the blue icons in the product tree underneath the search field, or
- on the website under Support in the Engineering software area, or
- on the DVD under Selection and sizing.

Parallel grippers

5

Type	 Parallel gripper DHPS	 Parallel gripper HGPD	 Parallel gripper HGPLE	 Parallel gripper HGPT-B
Total gripping force at 6 bar, closing	25 ... 910 N	94 ... 3,716 N		106 ... 6,300 N
Stroke per gripper jaw	2 ... 12.5 mm	3 ... 20 mm	40 mm	1.5 ... 25 mm
Position sensing	Via Hall sensor, via proximity sensor	Via proximity sensor	Via integrated angular displacement encoder	Via proximity sensor
Gripping force backup	During closing, during opening	During closing, during opening		During closing, during opening
Description	<ul style="list-style-type: none"> • Sturdy and precise T-slot guidance of the gripper jaws • High gripping force and compact size • Max. repetition accuracy • Wide range of options for mounting on drives 	<ul style="list-style-type: none"> • Ideal for very harsh environments • Precise gripping despite high torque loads • Max. gripping force combined with optimum • installation space/force ratio • 8 sizes with up to 40 mm total stroke • Repetition accuracy of 0 ... 0.05 mm 	<ul style="list-style-type: none"> • Electrically actuated gripper with long stroke • Free, speed-controlled selection of gripping positions • Long stroke allows use with workpieces of different sizes • Adjustable gripping force for highly sensitive and large, heavy workpieces • Very high torque resistance, very high accuracy • Short opening and closing times • Minimal installation costs • See product documentation for gripping force on our website 	<ul style="list-style-type: none"> • Sturdy and powerful • With T-slot guide • Suitable for external and internal gripping • Protection against dust in gripper jaw guide via sealing air • High-force variant (F) available
→ Page/online	483	hgpd	hgple	hgpt



Parallel grippers

Type	 Parallel gripper HGPL	 Parallel gripper HGPP	 Parallel gripper HGPC	 Parallel gripper HGP
Total gripping force at 6 bar, closing	158 ... 2,742 N	80 ... 830 N	44 ... 126 N	160 ... 340 N
Stroke per gripper jaw	20 ... 150 mm	2 ... 12.5 mm	3 ... 7 mm	5 ... 7.5 mm
Position sensing	Via proximity sensor	Via Hall sensor, via inductive sensor	Via proximity sensor	Via proximity sensor
Gripping force backup		During closing, during opening	During closing	
Description	<ul style="list-style-type: none"> Space-saving, high forces and torques Controlled, precise and centred gripping Long stroke: long guide length for the gripper jaws Suitable for external and internal gripping Opening stroke can be adjusted to optimise time 	<ul style="list-style-type: none"> High-precision gripper jaw guide Suitable for external and internal gripping Very flexible thanks to versatile attachment, mounting and application options 	<ul style="list-style-type: none"> Compact, low cost, reliable operation, long service life High force with minimal volume Suitable for external and internal gripping 	<ul style="list-style-type: none"> Double-acting piston drive With protective dust cap for use in dusty environments (protection class IP54) Self-centring Suitable for external and internal gripping High gripping force and compact size Max. repetition accuracy Internal fixed flow control Versatile thanks to externally adaptable gripper fingers Wide range of options for mounting on drive units
→ Page/online	hgpl	hgpp	hgpc	hgp



Parallel grippers

Type	 Parallel gripper HGPM
Total gripping force at 6 bar, closing	16 ... 35 N
Stroke per gripper jaw	2 ... 3 mm
Position sensing	None
Gripping force backup	
Description	<ul style="list-style-type: none"> Micro gripper: compact, handy design Versatile thanks to externally adaptable gripper fingers Mounting options with clamping spigot, with flange mounting, with Z-stroke compensation
→ Page/online	hgpm



Three-point grippers

			
Type	Three-point gripper DHDS	Three-point gripper HGDD	Three-point gripper HGDT
Total gripping force at 6 bar, closing	87 ... 750 N	336 ... 2,745 N	207 ... 2,592 N
Stroke per gripper jaw	2.5 ... 6 mm	4 ... 12 mm	1.5 ... 10 mm
Position sensing	Via Hall sensor, via proximity sensor	Via proximity sensor	Via proximity sensor
Gripping force backup	During closing	During closing, during opening	During closing, during opening
Description	<ul style="list-style-type: none"> Sturdy and precise T-slot guidance of the gripper jaws High gripping force and compact size Max. repetition accuracy Wide range of options for mounting on drives 	<ul style="list-style-type: none"> Ideal for very harsh environments Precise gripping with centric movements despite high torque loads 5 sizes with up to 12 mm stroke/jaw Repetition accuracy of 0 ... 0.05 mm 	<ul style="list-style-type: none"> Synchronous movement of gripper jaws With T-slot guide Suitable for external and internal gripping Dust-proof via sealing air High-force variant (F) available
→ Page/online	488	hgdd	hgdt

Angle grippers

			
Type	Angle gripper DHWS	Angle gripper HGWC	Angle gripper HGWM
Total gripping torque at 6 bar, closing	30 ... 1,362 Ncm	22 ... 144 Ncm	22 ... 64 Ncm
Max. opening angle	40°	30 ... 80°	14 ... 18.5°
Position sensing	Via Hall sensor, via proximity sensor	Via proximity sensor	None
Gripping force backup	During closing		
Description	<ul style="list-style-type: none"> Improved gripper jaw guide Link guided movement Internal fixed flow control Max. repetition accuracy Wide range of options for mounting on drives 	<ul style="list-style-type: none"> Internal fixed flow control, does away with the need for external flow control in 90% of applications High force with minimal volume Suitable for external and internal gripping Repetition accuracy ±0.05 mm Compact and cost-effective 	<ul style="list-style-type: none"> Micro angle gripper: compact, handy design Mounting options with clamping spigot, with flange mounting, with Z-stroke compensation Versatile thanks to externally adaptable gripper fingers
→ Page/online	492	hgwc	hgwm

Radial grippers

Type	 Radial gripper DHRS	 Radial gripper HGRT	 Radial gripper HGRC
Total gripping torque at 6 bar, closing	15 ... 660 Ncm	158 ... 7,754 Ncm	22 ... 144 Ncm
Max. opening angle	180°	180°	180°
Position sensing	Via Hall sensor, via proximity sensor	Via proximity sensor, via inductive sensor	Via proximity sensor
Description	<ul style="list-style-type: none"> • Lateral gripper jaw support for high torque loads • Self-centring • Gripper jaw centring options • Max. repetition accuracy 	<ul style="list-style-type: none"> • Secure gripping thanks to precise, polished plain-bearing guides • Gripping force backup via compression springs holds the gripped workpiece securely in the event of pressure failure • Compression spring also boosts the gripping force for applications involving heavier loads • Optimum cycle times thanks to freely adjustable opening angle of up to max. 90° per gripper finger. This prevents possible collisions due to the gripper jaws opening too wide 	<ul style="list-style-type: none"> • Internal fixed flow control, does away with the need for external flow control in 90% of applications • High force with minimal volume • Suitable for external and internal gripping • Repetition accuracy ±0.05 mm • Compact and cost-effective
→ Page/online	497	hgrt	hgrc

Swivel/gripper units

Type	 Swivel/gripper unit HGDS
Total gripping force at 6 bar, closing	74 ... 168 N
Stroke per gripper jaw	2.5 ... 7 mm
Swivel angle	210°
Position sensing, gripper	Via proximity sensor
Description	<ul style="list-style-type: none"> • Combination of parallel gripper and swivel module • Swivel angle infinitely adjustable • Precise end stop with elastic cushioning or integrated shock absorber
→ Page/online	hgds



Bellows gripper

	
Type	Bellows gripper DHEB
Bellows stroke	3.5 ... 25 mm
Min. diameter to be gripped	8 ... 66 mm
Max. diameter to be gripped	11 ... 85 mm
Max. operating frequency of gripper	0 ... 4 Hz
Description	<ul style="list-style-type: none"> • 11 sizes for gripping diameter from 8 to 85 mm • Upwards or downwards direction of movement of bellows • Different bellows materials (EPDM or silicone) • Air connection on the side or from above • Optimised process sequence with increased quality: prevents the workpieces from being scratched • Additional reliability: optional sensing via proximity or position sensor
→ Page/online	dheb

Software tool

<p>Feed separator</p> 	<p>This tool helps you to select the right separator of the type HPV from Festo for your application. Let yourself be guided by the program and enter the general parameters and you will receive at least one suggestion for the product best suited to your application.</p>	<p>This tool can be found</p> <ul style="list-style-type: none"> • in the electronic catalogue via the blue icons in the product tree underneath the search field, or • on the website under Support in the Engineering software area, or • on the DVD under Selection and sizing.
--	--	---

Feed separators

		
Type	Feed separator HPVS	Feed separator HPV
Mode of operation	Double-acting	Double-acting
Piston Ø	10 mm, 14 mm, 22 mm	10 mm, 14 mm, 22 mm
Stroke	10 ... 60 mm	20 ... 60 mm
Theoretical force at 6 bar, advancing	45 ... 225 N	45 ... 225 N
Description	<ul style="list-style-type: none"> • Version with one plunger • With non-rotating piston rod • Proximity sensors suitable for integration in the housing can be used (type SME/SMT-8) 	<ul style="list-style-type: none"> • Version with two plungers • With twin pistons, piston rods, non-rotating and locking mechanism • Cost-effective: replaces at least two drives in the feed process • Proximity sensors suitable for integration in the housing can be used (type SME/SMT-8)
→ Page/online	hpvs	hpv



- Oval piston for high gripping forces
- Gripping forces of up to 483 N
- With T-slot guide
- Internal fixed flow control
- With gripping force backup
- Spare parts service

→ www.festo.com/catalogue/dhps

Product range overview

Type/function	Size	Stroke per gripper jaw [mm]	Gripping force per gripper jaw [N]	Product options		
				A	NO	NC
DHPS						
Double-acting	6	2	13.5 ... 15	■	–	–
	10, 16, 20, 25, 35	3 ... 12.5	34.5 ... 483	■	■	■

Product options

A Position sensing

NO Opening gripping force backup

NC Closing gripping force backup

Technical data



Technical data		Dimensions → 487					
Size		6	10	16	20	25	35
Pneumatic connection		M3			M5	G1/8	
Stroke per gripper jaw	[mm]	2	3	5	6.5	7.5	12.5
Gripping force per gripper jaw at 6 bar	Opening [N]	15	39	105	162	249	483
	Closing [N]	13.5	34.5	96	147	228	450
Total gripping force at 6 bar	Opening [N]	30	80	210	320	500	970
	Closing [N]	25	70	190	290	450	910
Repetition accuracy ¹⁾	[mm]	≤ 0.02					
Max. operating frequency	[Hz]	4			3	2	

1) End-position drift under constant conditions of use with 100 consecutive strokes in the direction of movement of the gripper jaws.

Forces and torques

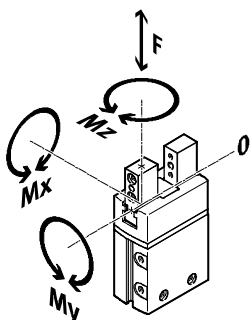

Size		6	10	16	20	25	35
Max. permissible force F_z	[N]	10	60	150	250	350	450
Max. permissible torque M_x	[Nm]	0.5	3	8	14	30	50
Max. permissible torque M_y	[Nm]	0.5	3	8	14	30	50
Max. permissible torque M_z	[Nm]	0.5	3	8	14	30	50

Parallel grippers DHPS

Technical data

Operating conditions		Without gripping force backup	With gripping force backup
Operating pressure	[bar]	2 ... 8	4 ... 8
Ambient temperature ¹⁾	[°C]	+5 ... +60	

1) Note operating range of proximity sensors.

Materials	
Housing	Hard anodised wrought aluminium alloy
Gripper jaw	High-alloy stainless steel
Cover cap	PA
Piston	POM
Piston rod	Tempered steel
Reversing lever	Hardened sintered steel
Seals	NBR

5

Order code

DHPS

A

Type	
DHPS	Parallel gripper

Size	
06, 10, 16, 20, 25, 35	

Position sensing	
A	Via proximity sensor

Gripping force backup	
–	None
NO	Opening 1
NC	Closing 1

1 Not with size 6 mm.

Ordering – Product options

Configurable product

This product and all its options can be ordered using the configurator.

The configurator can be found under Products on the DVD or
[→ www.festo.com/catalogue/...](http://www.festo.com/catalogue/...)

Enter the type code in the search field.

Accessories

DHPS-06

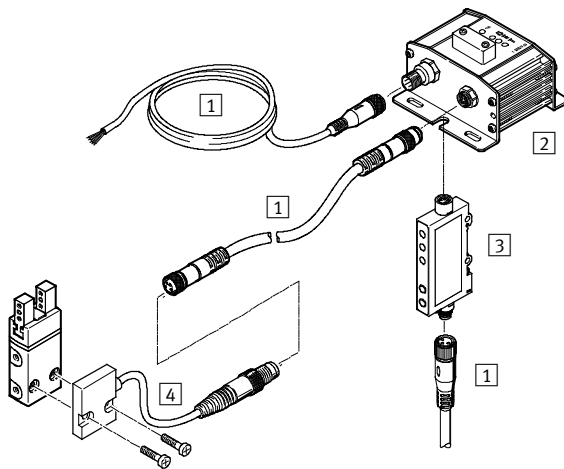

DHPS-10 ... 35

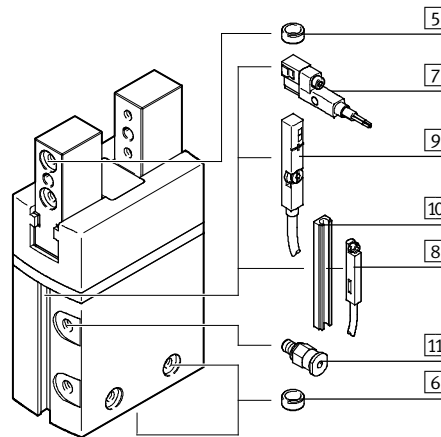







		→ Page/online
1	Connecting cable NEBU	485
2	Evaluation unit SMH-AE1	485
3	Signal converter SVE4	485
4	Position sensor SMH-S1	485

		→ Page/online
5	Centring sleeve ZBH	486
6	Centring sleeve ZBH	486
7	Proximity sensor SMT-8	486
8	Proximity sensor SMT-10	486
9	Position transmitter SMAT-8M	486
10	Bondable sensor rail HGP-SL	486
11	Push-in fitting QS	908
-	Connecting cable NEBU	486
-	One-way flow control valve GRLA	486
-	Drive/gripper connections	dhps

Accessories – Ordering data

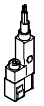
	For size	Part No.	Type	
1	Connecting cable			
	Connection between position sensor and signal converter/evaluation unit			
	2.5 m	554035	NEBU-M8G4-K-2.5-M8G4	
	Connection between evaluation unit and controller			
	2.5 m	541330	NEBU-M12G5-K-2.5-LE5	
	5 m	541331	NEBU-M12G5-K-5-LE5	
	Connection between signal converter and controller			
	2.5 m	541342	NEBU-M8G4-K-2.5-LE4	
	5 m	541343	NEBU-M8G4-K-5-LE4	
2	Evaluation unit, for size 6			Technical data online: → smh-ae
	PNP	175708	SMH-AE1-PS3-M12	
	NPN	175709	SMH-AE1-NS3-M12	
3	Signal converter, for size 6			Technical data online: → sve4
	PNP	544216	SVE4-HS-R-HM8-2P-M8	
	NPN	544219	SVE4-HS-R-HM8-2N-M8	
4	Position sensor, for size 6			Technical data online: → smh-s1
	Plug	175710	SMH-S1-HGP06	

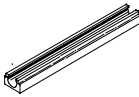
Accessories – Ordering data

	For size	Part No.	Type	
5	Centring sleeve for centring on the gripper jaws¹⁾²⁾			Technical data online: → zbh
	10	189652	ZBH-5	
	16, 20	186717	ZBH-7	
	25, 35	150927	ZBH-9	
6	Centring sleeve for centring the gripper¹⁾³⁾			Technical data online: → zbh
	6, 10	189652	ZBH-5	
	16, 20	186717	ZBH-7	
	25	150927	ZBH-9	
	35	189653	ZBH-12	
7	Proximity sensor for T-slot, for size 10 ... 35, magneto-resistive – N/O contact			Technical data online: → smt
	PNP, cable	547859	SMT-8G-PS-24V-E-2,5Q-OE	
	PNP, plug	547860	SMT-8G-PS-24V-E-0,3Q-M8D	
8	Proximity sensor for C-slot, for size 10 ... 35, magneto-resistive – N/O contact			Technical data online: → smt
	PNP, cable	547862	SMT-10G-PS-24V-E-2,5Q-OE	
	PNP, plug	547863	SMT-10G-PS-24V-E-0,3Q-M8D	
9	Position transmitter for T-slot, for size 10 ... 35			Technical data online: → smat
	Plug	553744	SMAT-8M-U-E-0,3-M8D	
10	Bondable sensor rail			
	10	535582	HGP-SL-10-10	
	16	535583	HGP-SL-10-16	
	20	535584	HGP-SL-10-20	
	25	535585	HGP-SL-10-25	
	35	535586	HGP-SL-10-35	
Connecting cable, straight socket				Technical data → 949
	2.5 m	★ 541333	NEBU-M8G3-K-2.5-LE3	
	5 m	★ 541334	NEBU-M8G3-K-5-LE3	
Angled socket				Technical data → 949
	2.5 m	★ 541338	NEBU-M8W3-K-2.5-LE3	
	5 m	★ 541341	NEBU-M8W3-K-5-LE3	

1) Packaging unit 10 pieces.

2) 4 included in the scope of delivery of the gripper.

3) 2 included in the scope of delivery of the gripper.

Function	For size	Connection		Part No.	Type
		Thread	O.D.		
One-way flow control valve for exhaust air flow control⁴⁾ with slotted head screw, metal					
	6, 10, 16	M3	3	175041	GRLA-M3-QS-3
	20		4	★ 193138	GRLA-M5-QS-4-D
	25, 35	G $\frac{1}{8}$	6	★ 193144	GRLA- $\frac{1}{8}$ -QS-6-D

4) The recommended flow control valves are based on a tubing length to the valve of 1 m. For deviations of $\pm 50\%$, flow control valves with a bigger or smaller flow rate must be selected to guarantee the optimum flow control function and cylinder speed.

Dimensions

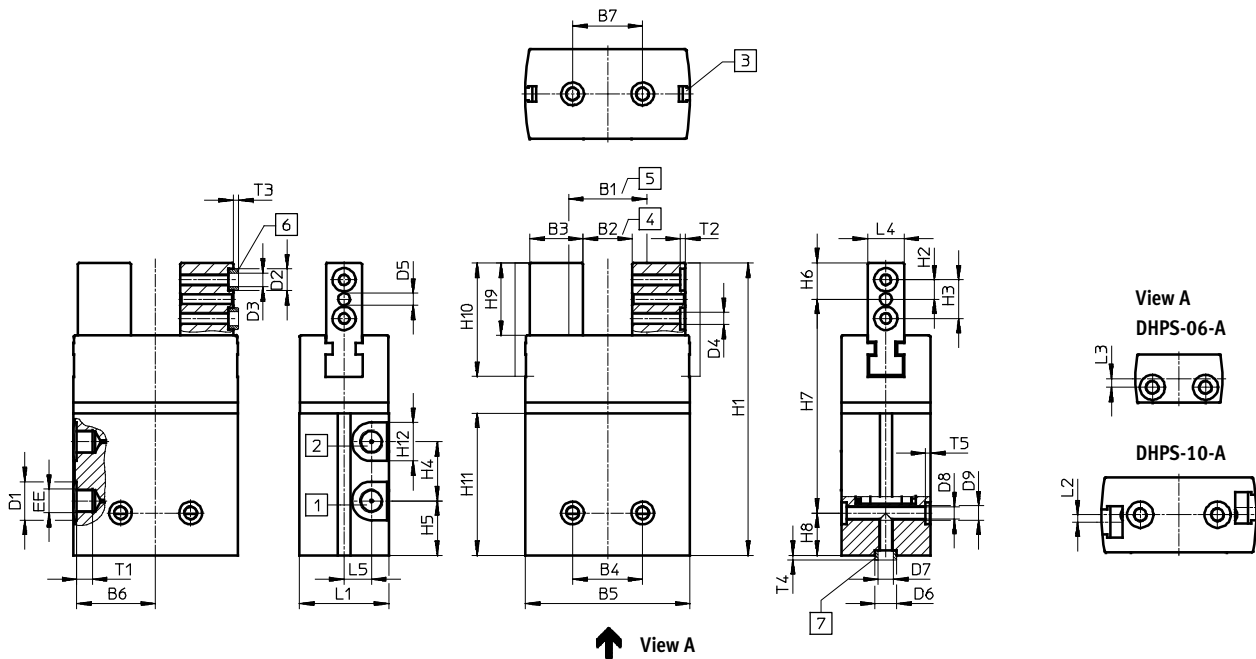

- 1 Supply port, opening
 2 Supply port, closing
 3 Slot for proximity sensor
 4 Normal position for DHPS...-A and DHPS...-A-NC
 5 Normal position for DHPS...-A-NO
 6 Centring sleeves ZBH (size 10 and above: 4 included in the scope of delivery)
 7 Centring sleeves ZBH (2 included in the scope of delivery)

Size	B1 ±0.5	B2 ±0.5	B3 -0.03	B4 ¹⁾	B5 ±0.1	B6	B7 ¹⁾	D1 ∅	D2 ∅ H8/h7	D3 ∅	D4	D5 ∅ H8	D6 ∅ H8/h7
6	10	6	5.5	11	18	8.65	11	7	-	-	M2	1.5	5
10	21.8	15.8	7	16	32	15.4	16	7	5	3.2	M3	2	5
16	27.8	17.8	13	25	47	22.65	25	7	7	5.3	M4	3	7
20	30	17	17.5	25	55.6	26.65	25	10	7	5.3	M4	4	7
25	35.4	20.4	22	29	68.2	32.65	29	16	9	6.4	M5	4	9
35	56	31	27	33	88	42.25	33	16	9	6.4	M6	5	12

Size	D7 ∅	D8 ∅ +0.1	D9	EE	H1	H2	H3 ¹⁾	H4	H5	H6	H7 ±0.2	H8 ²⁾	H9
6	-	2.5	M3	M3	45.5	2.9	5.8	15	4	5	33	7.5	9.55
10	3.2	2.5	M3	M3	66	4	8	15.5	10.5	7.5	51	7.5	15.2
16	5.3	3.3	M4	M3	80	5.5	11	18	11	10	62.5	7.5	20
20	5.3	3.3	M4	M5	101	7	14	23	16	12.5	81	7.5	25
25	6.4	5.1	M6	G1/8	121	8	16	24.5	22.5	15	88.5	17.5	30
35	10.3	6.4	M8	G1/8	142	8.5	17	29	24	16	108.5	17.5	32

Size	H10	H11	H12	L1	L2	L3 ¹⁾	L4 -0.05	L5	T1 +0.5	T2 +0.1	T3 -0.2	T4 -0.2	T5 +0.1
6	15.8	25.3	7	10 ^{+0.1}	-	1.8	5	1.5	3.5	-	-	1.2	1.2
10	23	35	7	15.5 ^{+0.1}	1.5	-	7	5	5	1.2	1.2	1.2	1.2
16	32.5	38.1	7	22 ^{+0.1}	-	-	10	7	6	1.6	1.4	1.4	1.6
20	39.5	50	10	30±0.1	-	-	12	9	6	1.6	1.4	1.4	1.6
25	47	58.8	16	37±0.1	-	-	15	11.3	6.5	2.1	1.9	1.9	2.1
35	53	65.3	16	45 ^{+0.1}	-	-	20	13.5	6.5	2.1	1.9	2.4	2.6

1) Tolerance for centring hole ±0.02 mm, tolerance for thread ±0.1 mm

2) Tolerance for centring hole -0.05 mm, tolerance for thread ±0.1 mm

Three-point grippers DHDS



- High gripping forces
- Gripping forces of up to 280 N
- With T-slot guide
- Internal fixed flow control
- With gripping force backup
- Spare parts service

→ www.festo.com/catalogue/dhds

Product range overview

Type/function	Size	Stroke per gripper jaw [mm]	Gripping force per gripper jaw [N]	Product options	
				A	NC
DHDS					
Double-acting	16, 32, 50	2.5 ... 6	29 ... 280	■	■

Product options

A Position sensing

NC Closing gripping force backup

Technical data

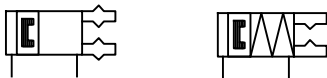

Technical data

Dimensions → 491

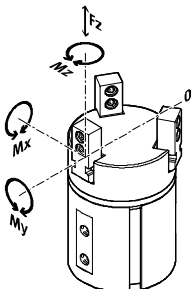

Size	16	32	50
Pneumatic connection	M3	M5	G1/8
Stroke per gripper jaw [mm]	2.5	3.9	6
Gripping force per gripper jaw at 6 bar	Opening [N]	135	280
	Closing [N]	29	115
Total gripping force at 6 bar	Opening [N]	405	840
	Closing [N]	87	345
Repetition accuracy ¹⁾ [mm]	≤ 0.04		
Max. operating frequency [Hz]	4		
Max. permissible force F_z [N]	50	150	250
Max. permissible torque M_x [Nm]	2	9	24
Max. permissible torque M_y [Nm]	2	9	24
Max. permissible torque M_z [Nm]	2	9	24

1) End-position drift under constant conditions of use with 100 consecutive strokes in the direction of movement of the gripper jaws.

Operating conditions

Operating conditions	Without gripping force backup	With gripping force backup
Operating pressure [bar]	2 ... 8	4 ... 8
Ambient temperature ¹⁾ [°C]	+5 ... +60	

1) Note operating range of proximity sensors.

Materials

Housing	Hard anodised wrought aluminium alloy
Gripper jaw	High-alloy stainless steel
Cover cap	PA
Piston	POM
Reversing lever	Hardened sintered steel
Seals	NBR

Order code

DHDS		A																			
<table border="1"> <tr> <td colspan="2">Type</td> </tr> <tr> <td>DHDS</td> <td>Three-point gripper</td> </tr> <tr> <td colspan="2">Size</td> </tr> <tr> <td>16, 32, 50</td> <td></td> </tr> <tr> <td colspan="2">Position sensing</td> </tr> <tr> <td>A</td> <td>Via proximity sensor</td> </tr> <tr> <td colspan="2">Gripping force backup</td> </tr> <tr> <td>-</td> <td>None</td> </tr> <tr> <td>NC</td> <td>Closing</td> </tr> </table>				Type		DHDS	Three-point gripper	Size		16, 32, 50		Position sensing		A	Via proximity sensor	Gripping force backup		-	None	NC	Closing
Type																					
DHDS	Three-point gripper																				
Size																					
16, 32, 50																					
Position sensing																					
A	Via proximity sensor																				
Gripping force backup																					
-	None																				
NC	Closing																				

Ordering – Product options

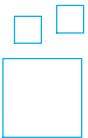

Configurable product

This product and all its options can be ordered using the configurator.

The configurator can be found under Products on the DVD or
 → www.festo.com/catalogue/...

Enter the type code in the search field.

Accessories

DHDS-16

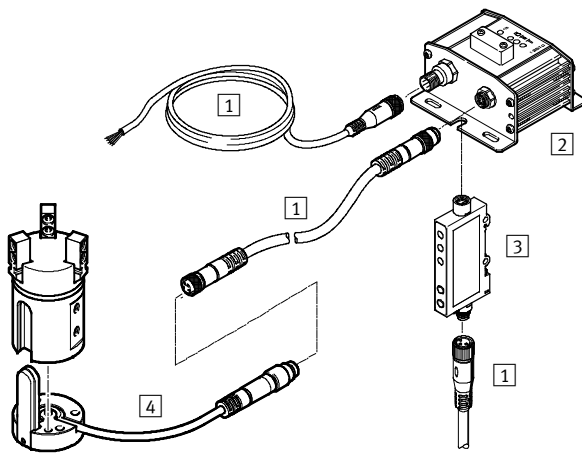

	→ Page/online
1 Connecting cable NEBU	490
2 Evaluation unit SMH-AE1	490
3 Signal converter SVE4	490
4 Position sensor SMH-S1	490
5 Centring sleeve ZBH	490
6 Push-in fitting QS	908



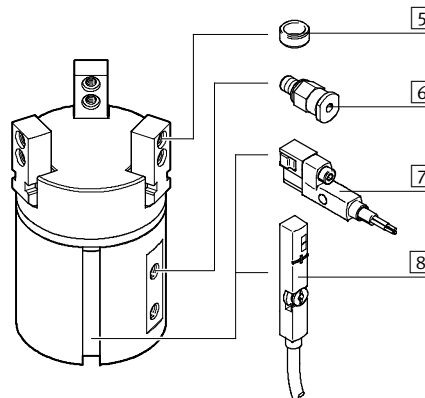



DHDS-32, 50

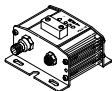
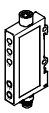
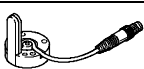

	→ Page/online
7 Proximity sensor SMT-8	490
8 Position transmitter SMAT-8M	490
- Connecting cable NEBU	490
- One-way flow control valve GRLA	490
- Drive/gripper connections	dhds

Three-point grippers DHDS

Accessories – Ordering data

	For size	Part No.	Type	
1 Connecting cable				
	Connection between position sensor and signal converter/evaluation unit			
	2.5 m	554035	NEBU-M8G4-K-2.5-M8G4	
	Connection between evaluation unit and controller			
	2.5 m	541330	NEBU-M12G5-K-2.5-LE5	
	5 m	541331	NEBU-M12G5-K-5-LE5	
	Connection between signal converter and controller			
	2.5 m	541342	NEBU-M8G4-K-2.5-LE4	
	5 m	541343	NEBU-M8G4-K-5-LE4	
2 Evaluation unit, for size 16 Technical data online: → smh-ae				
	PNP	175708	SMH-AE1-PS3-M12	
	NPN	175709	SMH-AE1-NS3-M12	
3 Signal converter, for size 16 Technical data online: → sve4				
	PNP	544216	SVE4-HS-R-HM8-2P-M8	
	NPN	544219	SVE4-HS-R-HM8-2N-M8	
4 Position sensor, for size 16 Technical data online: → smh-s1				
	Plug	175713	SMH-S1-HGD16	
5 Centring sleeve¹⁾²⁾ Technical data online: → zbh				
	16, 32	189652	ZBH-5	
	50	186717	ZBH-7	
7 Proximity sensor for T-slot, for size 32 ... 50, magneto-resistive – N/O contact Technical data online: → smt				
	PNP, cable	547859	SMT-8G-PS-24V-E-2,5Q-OE	
	PNP, plug	547860	SMT-8G-PS-24V-E-0,3Q-M8D	
8 Position transmitter for T-slot, for size 32 ... 50 Technical data online: → smat				
	Plug	553744	SMAT-8M-U-E-0,3-M8D	
Connecting cable, straight socket Technical data → 949				
	2.5 m	★	541333	NEBU-M8G3-K-2.5-LE3
	5 m	★	541334	NEBU-M8G3-K-5-LE3
Angled socket Technical data → 949				
	2.5 m	★	541338	NEBU-M8W3-K-2.5-LE3
	5 m	★	541341	NEBU-M8W3-K-5-LE3

1) Packaging unit 10 pieces.

2) 6 included in the scope of delivery of the gripper.

Function	For size	Connection		Part No.	Type
		Thread	O.D.		
One-way flow control valve for exhaust air flow control³⁾ with slotted head screw, metal Technical data → 609					
	16	M3	3	175041	GRLA-M3-QS-3
	32	M5	4	★	193138 GRLA-M5-QS-4-D
	50	G ¹ / ₈	6	★	193144 GRLA-1/8-QS-6-D

3) The recommended flow control valves are based on a tubing length to the valve of 1 m. For deviations of ±50%, flow control valves with a bigger or smaller flow rate must be selected to guarantee the optimum flow control function and cylinder speed.

Dimensions

Download CAD data → www.festo.com

DHDS-16

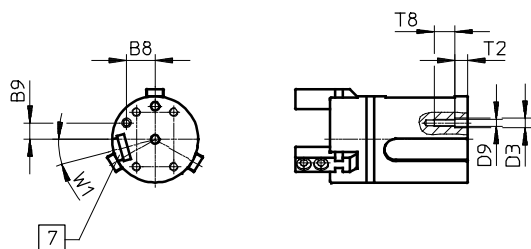

DHDS-32, 50

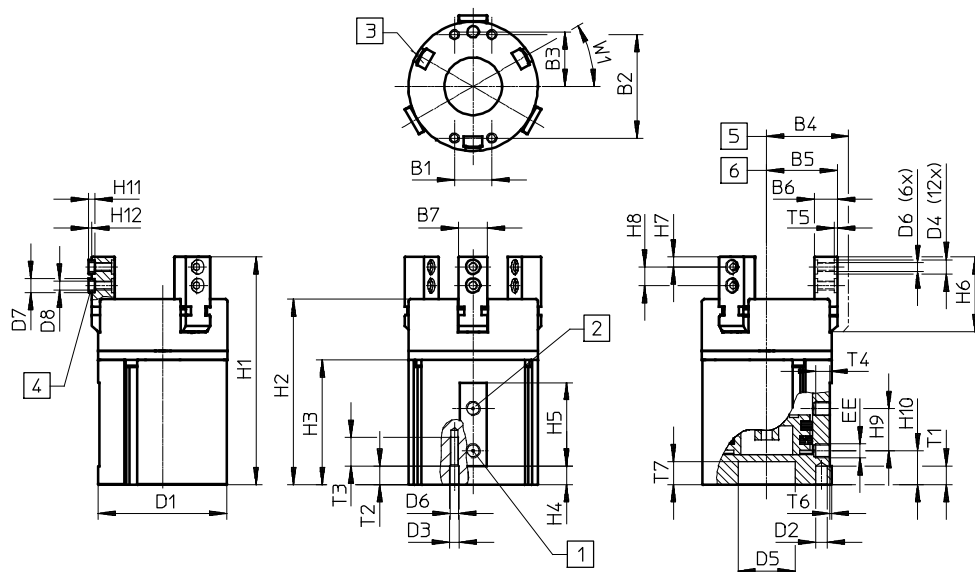

- 1 Supply port, opening
- 2 Supply port, closing
- 3 Slot for proximity sensor
- 4 Centring sleeve ZBH
(6 included in the scope of delivery)
- 5 Gripper jaw open
- 6 Gripper jaw closed
- 7 Slot for position sensor

Size	B1	B2	B3	B4	B5	B6	B7	B8	B9
			±0.02	±0.5	±0.5	-0.02/-0.05	-0.02	-0.1	-0.1
16	13	19	11.5	20	17.5	7	6	9.96	5.75
32	13	36	19	28.5	24.6	8	10	-	-
50	25	54	30	43	37	12	14	-	-

Size	D1	D2	D3	D4	D5	D6	D7	D8	D9
	∅	∅ H8	∅ H8	∅ H8	∅ +0.05/+0.02		∅ h7	∅	
16	30	3	3.2	5	-	M3	5	3.2	M2.5
32	45	4	3.5	5	20	M3	5	3.2	-
50	70	5	6	7	30	M5	7	5.3	-

Size	EE	H1	H2	H3	H4	H5	H6	H7	H8 ¹⁾	H9
16	M3	60	47.9	32.6	4.5	24	21.5	3	6	12
32	M5	78	63.2	42.2	5.2	29	26	3.5	6.5	14.7
50	G1/8	107.5	86.5	56	6.7	40	37	5	10	22

Size	H10	T1	T2	T3	T4	T5	T6	T7	T8	W1
		min.	min.	+1	-0.5	+0.1	±0.2		±1	
16	11	4.5	4.5	8	4	1.2	1	-	7	15°
32	10.5	6.5	6.5	10	4	1.1	0.5	8	-	30°
50	16	7	7	18	6	1.6	1	9	-	30°

1) Tolerance for centring hole ±0.02 mm, tolerance for thread ±0.1 mm



- Link guided movement
- Gripping torques of up to 1,497 Ncm
- Internal fixed flow control
- With gripping force backup
- Spare parts service

→ www.festo.com/catalogue/dhws

5

Product range overview

Type/function	Size	Opening angle [°]	Total gripping torque [Ncm]	Product options	
				A	NC
DHWS					
Double-acting	10	40	30 ... 43	■	–
	16, 25, 32, 40	40	114 ... 1,497	■	■

Product options

A Position sensing NC Closing gripping force backup

Technical data



Technical data						Dimensions → 496				
Size	10		16		25		32		40	
Pneumatic connection	M3		M3		M5		G1/8			
Opening angle per gripper jaw	[°]		20							
Total gripping torque at 6 bar	Opening	[Ncm]	43	129	386	810	1,497			
	Closing	[Ncm]	30	114	356	746	1,362			
Repetition accuracy ¹⁾	[mm]		≤ 0.04							
Max. operating frequency	[Hz]		4		3					

1) End-position drift under constant conditions of use with 100 consecutive strokes in the direction of movement of the gripper jaws.

Forces and torques

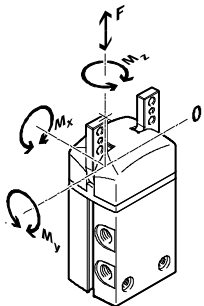

Size	10	16	25	32	40
Max. permissible force F_z [N]	25	50	90	120	200
Max. permissible torque M_x [Nm]	0.6	1.6	3.6	6	13
Max. permissible torque M_y [Nm]	0.6	1.6	3.6	6	13
Max. permissible torque M_z [Nm]	0.6	1.6	3.6	6	13

Technical data

Operating conditions		Without gripping force backup	With gripping force backup
Operating pressure	[bar]	2 ... 8	4 ... 8
Ambient temperature ¹⁾	[°C]	+5 ... +60	

1) Note operating range of proximity sensors.

Materials	
Housing	Hard anodised wrought aluminium alloy
Gripper jaw	High-alloy stainless steel
Cover cap	PA
Piston	POM
Slotted guide plate	Tempered steel
Reversing lever	Hardened sintered steel
Seals	NBR

Order code

DHWS		-		[]		-		A		-		[]	
Type		DHWS		Angle gripper									
Size		10, 16, 25, 32, 40											
Position sensing		A		Via proximity sensor									
Gripping force backup		-		None									
		NC		Closing		1							

1) Not with size 10 mm.

Ordering – Product options

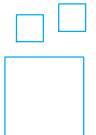
	Configurable product	This product and all its options can be ordered using the configurator.	The configurator can be found under Products on the DVD or www.festo.com/catalogue/...	Enter the type code in the search field.
---	-----------------------------	--	--	--

Accessories

DHWS-10

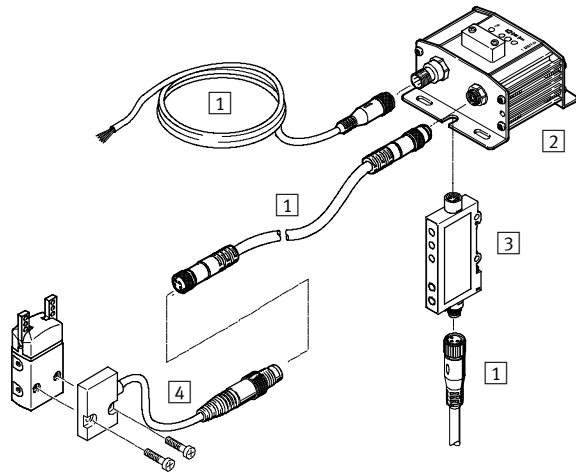

DHWS-16 ... 40

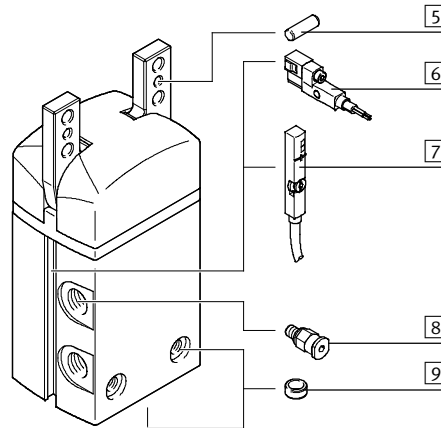

5





		→ Page/online
1	Connecting cable NEBU	494
2	Evaluation unit SMH-AE1	494
3	Signal converter SVE4	494
4	Position sensor SMH-S1	494
5	Centring pin	-
6	Proximity sensor SMT-8	495

		→ Page/online
7	Position transmitter SMAT-8M	495
8	Push-in fitting QS	908
9	Centring sleeve ZBH	495
-	Connecting cable NEBU	495
-	One-way flow control valve GRLA	495
-	Drive/gripper connections	dhws

Accessories – Ordering data

	For size	Part No.	Type	
1 Connecting cable				
	Connection between position sensor and signal converter/evaluation unit			
	2.5 m	554035	NEBU-M8G4-K-2.5-M8G4	
	Connection between evaluation unit and controller			
	2.5 m	541330	NEBU-M12G5-K-2.5-LE5	
	5 m	541331	NEBU-M12G5-K-5-LE5	
	Connection between signal converter and controller			
2.5 m	541342	NEBU-M8G4-K-2.5-LE4		
5 m	541343	NEBU-M8G4-K-5-LE4		
2 Evaluation unit, for size 10				
	PNP	175708	SMH-AE1-PS3-M12	Technical data online: → smh-ae
	NPN	175709	SMH-AE1-NS3-M12	
3 Signal converter, for size 10				
	PNP	544216	SVE4-HS-R-HM8-2P-M8	Technical data online: → sve4
	NPN	544219	SVE4-HS-R-HM8-2N-M8	
4 Position sensor, for size 10				
	Plug	175711	SMH-S1-HGW10	Technical data online: → smh-s1

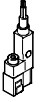
Accessories – Ordering data

	For size		Part No.	Type	
Connecting cable, straight socket					Technical data → 949
	2.5 m	★	541333	NEBU-M8G3-K-2.5-LE3	
	5 m	★	541334	NEBU-M8G3-K-5-LE3	
Angled socket					Technical data → 949
	2.5 m	★	541338	NEBU-M8W3-K-2.5-LE3	
	5 m	★	541341	NEBU-M8W3-K-5-LE3	
6 Proximity sensor for T-slot, for size 16 ... 40, magneto-resistive – N/O contact					Technical data online: → smt
	PNP, cable		547859	SMT-8G-PS-24V-E-2,5Q-OE	
	PNP, plug		547860	SMT-8G-PS-24V-E-0,3Q-M8D	
7 Position transmitter for T-slot, for size 16 ... 40					Technical data online: → smat
	Plug		553744	SMAT-8M-U-E-0,3-M8D	
9 Centring sleeve¹⁾²⁾					Technical data online: → zbh
	10, 16		189652	ZBH-5	
	25		186717	ZBH-7	
	32		150927	ZBH-9	
	40		189653	ZBH-12	

1) Packaging unit 10 pieces.

2) 2 included in the scope of delivery of the gripper.

Function	For size	Connection		Part No.	Type
		Thread	O.D.		
One-way flow control valve for exhaust air flow control³⁾ with slotted head screw, metal					
	10, 16	M3	3	175041	GRLA-M3-QS-3
	25	M5	4	★ 193138	GRLA-M5-QS-4-D
	32, 40	G1/8	6	★ 193144	GRLA-1/8-QS-6-D

3) The recommended flow control valves are based on a tubing length to the valve of 1 m. For deviations of ±50%, flow control valves with a bigger or smaller flow rate must be selected to guarantee the optimum flow control function and cylinder speed.

Angle grippers DHWS

Dimensions

Download CAD data → www.festo.com

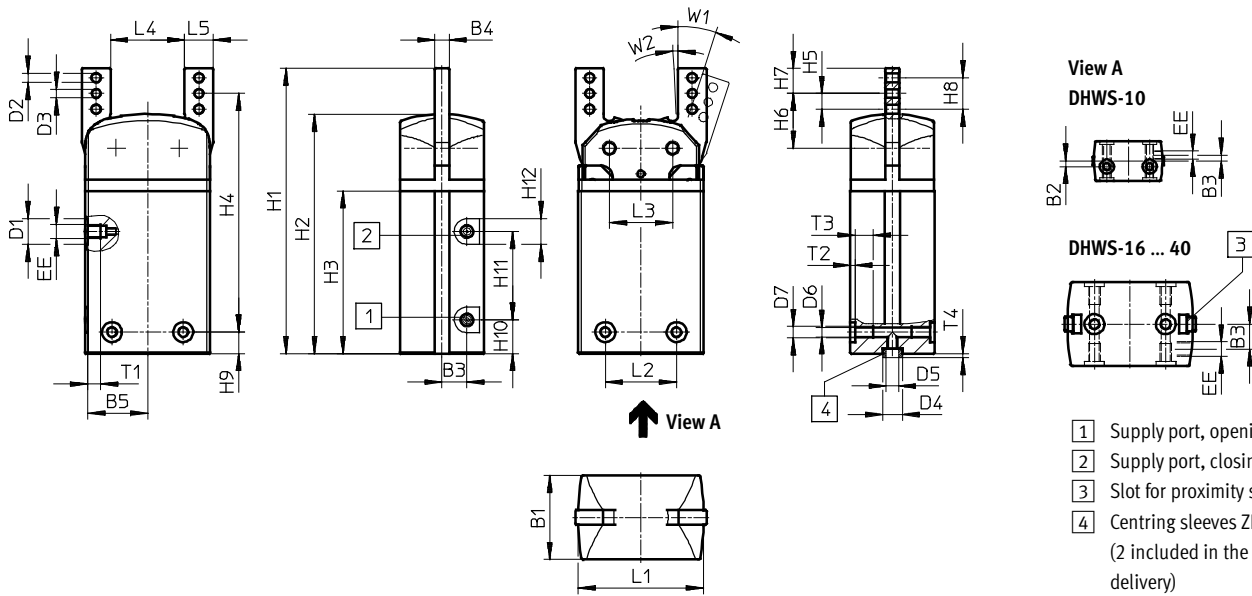

5

Size	B1 ±0.05	B2 ¹⁾	B3	B4 -0.03/-0.05	B5	D1 ∅	D2 ∅ ±0.1	D3 ∅ H8	D4 ∅ H8/h7
10	14	2	2	3	11.6	7	2.2	2	5
16	19	-	5.8	4	16	-	3.2	2.5	5
25	29.5	-	8.75	5	21	9	3.2	3	7
32	38	-	11	6	24	15	4.3	3	9
40	49	-	11	8	28.4	15	5.3	4	12

Size	D5 ∅	D6 +0.1	D7	EE	H1	H2	H3	H4 ±0.2	H5
10	3.2	2.4	M3	M3	56.3	46	30.8	38.25	3.5
16	3.2	2.5	M3	M3	81	67	45.5	66	4.5
25	5.3	3.3	M4	M5	100	84	57	83.7	5.5
32	6.4	5.1	M6	G $\frac{1}{8}$	116	96.2	65	100.5	6.5
40	10.3	6.4	M8	G $\frac{1}{8}$	129	108.4	71.5	99.5	7

Size	H6 ±0.05	H7	H8	H9 ²⁾	H10	H11	H12	L1 ±0.05	L2 ¹⁾
10	10.95	5.75	7	12.3	8.8	16	7	24	15
16	15.5	7.5	9	7.5	12.25	23	7	34	16
25	19.2	8.8	11	7.5	11.8	31	9	44	25
32	22.5	11	13	11	20	25	15	53	29
40	24.5	12	14	17.5	9	46	15	59	33

Size	L3 ±0.02	L4	L5 -0.02/-0.05	T1 +0.5	T2 +0.1	T3 +1	T4 -0.2	W1 +3°/-1°	W2 ±1°
10	12.4	14	5.5	3.5	1.2	through	1.2	18	3
16	17	18	8	4.5	1.2	5.8	1.2	18	3
25	22.2	26	10	4.5	1.6	6.4	1.4	18	3
32	25.8	29	12	7.5	2.1	12.9	1.9	18	3
40	30	32	15	6	2.6	13.4	2.4	18	3

1) Tolerance for centring hole ±0.02 mm, tolerance for thread ±0.1 mm
 2) Tolerance for centring hole -0.05 mm, tolerance for thread ±0.1 mm



- High torque load
- Gripping torques of up to 725 Ncm
- Self-centring
- Internal fixed flow control
- With gripping force backup
- Spare parts service

→ www.festo.com/catalogue/dhrs

Product range overview

Type/function	Size	Opening angle [°]	Total gripping torque [Ncm]	Product overview	
				A	NC
DHRS					
Double-acting	10	180	15 ... 21	■	–
	16, 25, 32, 40	180	55 ... 725	■	■

Product overview

A Position sensing

NC Closing gripping force backup

Technical data



Technical data						Dimensions → 501	
Size	10	16	25	32	40		
Pneumatic connection	M3		M5	G1/8			
Max. opening angle	[°] 180						
Total gripping torque at 6 bar	Opening	[Ncm] 21	62	233	423	725	
	Closing	[Ncm] 15	55	215	390	660	
Repetition accuracy ¹⁾	[mm] ≤ 0.1						
Max. operating frequency	[Hz] 4		3	2			

1) End-position drift under constant conditions of use with 100 consecutive strokes in the direction of movement of the gripper jaws.

Forces and torques

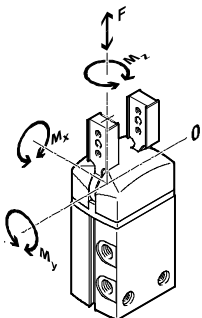

Size	10	16	25	32	40
Max. permissible force F_z	[N] 30	40	75	120	200
Max. permissible torque M_x	[Nm] 0.8	1.3	3.2	6.2	14
Max. permissible torque M_y	[Nm] 0.8	1.3	3.2	6.2	14
Max. permissible torque M_z	[Nm] 0.8	1.3	3.2	6.2	14

Technical data

Operating conditions		Without gripping force backup	With gripping force backup
Operating pressure	[bar]	2 ... 8	4 ... 8
Ambient temperature ¹⁾	[°C]	+5 ... +60	

1) Note operating range of proximity sensors.



Materials	
Housing	Hard anodised wrought aluminium alloy
Gripper jaw	High-alloy stainless steel
Cover cap	PA
Piston	POM
Slotted guide plate	Tempered steel
Seals	NBR

Order code

DHRS		-		[]		-		A		-		[]	
Type		DHRS		Radial gripper									
Size		10, 16, 25, 32, 40											
Position sensing		A		Via proximity sensor									
Gripping force backup		-		None									
		NC		Closing		1							

1) Not with size 10 mm.

Ordering – Product options

 	Configurable product	This product and all its options can be ordered using the configurator.	The configurator can be found under Products on the DVD or → www.festo.com/catalogue/...	Enter the type code in the search field.
--	-----------------------------	--	--	--

Accessories

DHRS-10

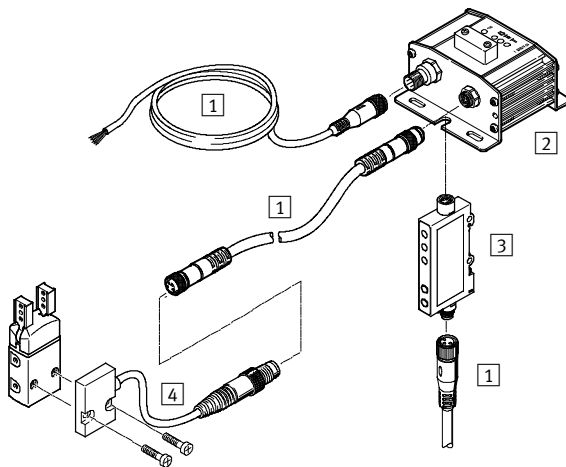

DHRS-16 ... 40

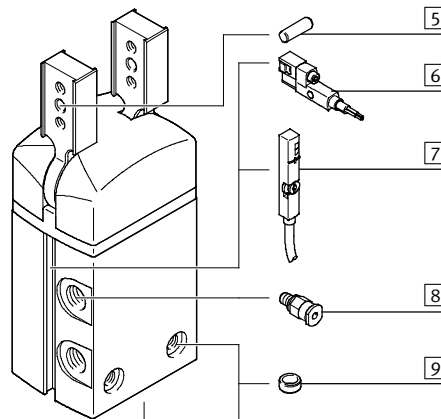





		→ Page/online
1	Connecting cable NEBU	499
2	Evaluation unit SMH-AE1	499
3	Signal converter SVE4	499
4	Position sensor SMH-S1	499
5	Centring pin	-
6	Proximity sensor SMT-8	500

		→ Page/online
7	Position transmitter SMAT-8M	500
8	Push-in fitting QS	908
9	Centring sleeve ZBH	500
-	Connecting cable NEBU	500
-	One-way flow control valve GRLA	500
-	Drive/gripper connections	dhrs

Accessories – Ordering data

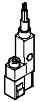
	For size	Part No.	Type	
1 Connecting cable				
	Connection between evaluation unit/signal converter and position sensor			
	2.5 m	554035	NEBU-M8G4-K-2.5-M8G4	
	Connection between evaluation unit and controller			
	2.5 m	541330	NEBU-M12G5-K-2.5-LE5	
	5 m	541331	NEBU-M12G5-K-5-LE5	
	Connection between signal converter and controller			
2.5 m	541342	NEBU-M8G4-K-2.5-LE4		
5 m	541343	NEBU-M8G4-K-5-LE4		
2 Evaluation unit, for size 10				
	PNP	175708	SMH-AE1-PS3-M12	Technical data online: → smh-ae
	NPN	175709	SMH-AE1-NS3-M12	
3 Signal converter, for size 10				
	PNP	544216	SVE4-HS-R-HM8-2P-M8	Technical data online: → sve4
	NPN	544219	SVE4-HS-R-HM8-2N-M8	
4 Position sensor, for size 10				
	Plug	175712	SMH-S1-HGR10	Technical data online: → smh-s1

Accessories – Ordering data

	For size	Part No.	Type	
6 Proximity sensor for T-slot, for size 16 ... 40, magneto-resistive – N/O contact Technical data online: → smt				
	PNP, cable	547859	SMT-8G-PS-24V-E-2,5Q-OE	
	PNP, plug	547860	SMT-8G-PS-24V-E-0,3Q-M8D	
7 Position transmitter for T-slot, for size 16 ... 40 Technical data online: → smat				
	Plug	553744	SMAT-8M-U-E-0,3-M8D	
9 Centring sleeve¹⁾²⁾ Technical data online: → zbh				
	10, 16	189652	ZBH-5	
	25	186717	ZBH-7	
	32	150927	ZBH-9	
	40	189653	ZBH-12	
Connecting cable, straight socket Technical data → 949				
	2.5 m	★ 541333	NEBU-M8G3-K-2.5-LE3	
	5 m	★ 541334	NEBU-M8G3-K-5-LE3	
Angled socket Technical data → 949				
	2.5 m	★ 541338	NEBU-M8W3-K-2.5-LE3	
	5 m	★ 541341	NEBU-M8W3-K-5-LE3	

1) Packaging unit 10 pieces.

2) 2 included in the scope of delivery of the gripper.

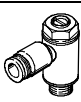
Function	For size	Connection		Part No.	Type
		Thread	O.D.		
One-way flow control valve for exhaust air flow control³⁾ with slotted head screw, metal Technical data → 609					
	10, 16	M3	3	175041	GRLA-M3-QS-3
	25	M5	4	★ 193138	GRLA-M5-QS-4-D
	32, 40	G $\frac{1}{8}$	6	★ 193144	GRLA- $\frac{1}{8}$ -QS-6-D

3) The recommended flow control valves are based on a tubing length to the valve of 1 m. For deviations of ±50%, flow control valves with a bigger or smaller flow rate must be selected to guarantee the optimum flow control function and cylinder speed.

Dimensions

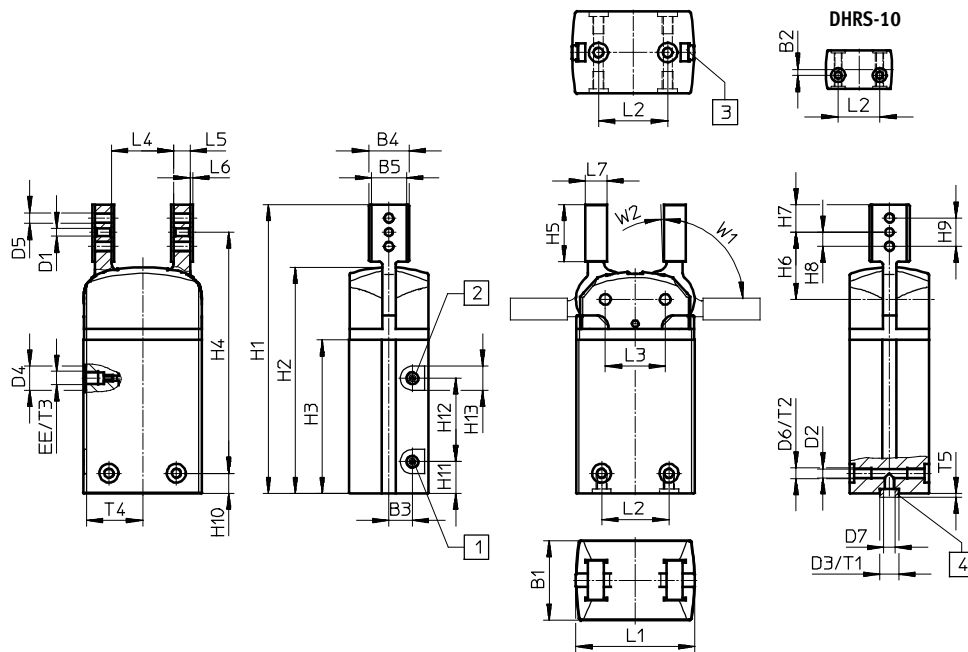
Download CAD data → www.festo.com

- 1) Supply port, opening
 2) Supply port, closing
 3) Slot for proximity sensor
 4) Centring sleeves ZBH
 (2 included in the scope of delivery)

Size	B1	B2 ¹⁾	B3	B4	B5	D1	D2	D3	D4	D5
	±0.05				+0.03/ +0.01	∅ H8	∅ +0.1	∅ H8/h7	∅	
10	14	2	2	8.5	6.5	2	2.4	5	7	M2.5
16	19	–	5.8	14	10	2	2.5	5	–	M3
25	29.5	–	8.75	15	13	3	3.3	7	9	M4
32	38	–	11	16	14	4	5.1	9	15	M5
40	49	–	11	24	20	5	6.4	12	15	M6

Size	D6	D7	EE	H1	H2	H3	H4	H5	H6	H7
		∅					±0.25	±0.2	±0.05	–0.1
10	M3	3.2	M3	60.8	46	30.8	42.25	13.8	14.95	6.25
16	M3	3.2	M3	88.2	70.5	49	73.70	16.5	19.7	7
25	M4	5.3	M5	107.2	84	57	89.45	21.2	24.95	10.25
32	M6	6.4	G $\frac{1}{8}$	128.5	96.2	65	103.5	29.5	32	14
40	M8	10.3	G $\frac{1}{8}$	140	108.4	71.5	108.7	29.5	33.7	13.8

Size	H8	H9	H10 ²⁾	H11	H12	H13	L1	L2 ¹⁾	L3	L4
							±0.05		±0.02	
10	4	8	12.3	8.8	16	7	24	15	12.4	12
16	4	8	7.5	12.25	23	7	33.4	16	17	21
25	5.25	10.5	7.5	11.8	31	9	44	25	22.2	23.2
32	7	14	11	20	25	15	51	29	25.8	24.8
40	8	16	17.5	9	46	15	59	33	30	29.6

Size	L5	L6	L7	T1	T2	T3	T4	T5	W1	W2
	±0.05			+0.1	+1	+0.5		–0.3	±2°	+3°
10	4	0.5	5	1.2	through	3.5	11.6	1.2	90	2
16	4	1	6	1.2	5.8	4.5	16	1.2	90	2
25	6	1	8	1.6	6.4	4.5	21	1.4	90	2
32	8	1	10	2.1	12.9	6.5	24	1.9	90	2
40	10	1	12	2.6	13.4	6	28.4	2.4	90	2

1) Tolerance for centring hole ±0.02 mm, tolerance for thread ±0.1 mm
 2) Tolerance for centring hole –0.05 mm, tolerance for thread ±0.1 mm



6 Handling systems



Software tool

<p>Configurator</p> 	<p>Design a product with numerous features reliably and quickly with the help of the configurator. Select all the required product features step-by-step. The use of logic checks ensures that only correct configurations are available for selection.</p>	<p>The configurator is part of the electronic catalogue and is not available as a separate software program.</p>
--	---	--

Handling modules

<p>Type</p>	 Handling module HSP	 Handling module, pneumatic HSW-AP, HSW-AS	 Handling module, electric HSW-AE
Size	12, 16, 25	10, 12, 16	10, 12, 16
Theoretical force at 6 bar	40 ... 65 N	30 ... 55 N	
Minimum cycle time	0.6 ... 1 s	0.6 ... 1 s	0.8 ... 1.2 s
Y-stroke	52 ... 170 mm		
Z-stroke	20 ... 70 mm	80 ... 100 mm	80 ... 100 mm
Repetition accuracy	+/-0.01 mm, +/-0.02 mm		
Description	<ul style="list-style-type: none"> • Function module for the automatic transfer, feed and removal of small parts in extremely confined spaces • Guided vertical and horizontal motion sequence • High precision and good rigidity • Compact design • Extremely short cycle times • Cost-optimised • Stroke adjustment along Y and Z-axes 	<ul style="list-style-type: none"> • Function module for the automatic transfer, feed and removal of small parts in extremely confined spaces • Guided swivel and linear motion • High precision and good rigidity • HSW-AP: pneumatic, with swivel module DSM; HSW-AS: without drive, with drive shaft • Fast and compact • Low-cost and ideal for universal use 	<ul style="list-style-type: none"> • Function module for the automatic transfer, feed and removal of small parts in extremely confined spaces • Guided swivel and linear motion • High precision and good rigidity • Electric, with motor unit MTR-DCI • Freely positionable, freely selectable speed • Smooth motion sequence • Simple commissioning using teach-in procedure
→ Page/online	hsp	hsw	hsw

Linear gantries

<p>Type</p>	 Linear gantry DHSL
Effective load	0 ... 50 kg
Y-stroke	0 ... 8,500 mm
Z-stroke	0 ... 1,000 mm
Description	<ul style="list-style-type: none"> • Different variants consisting of linear drives and slide drives • Electric and pneumatic actuation • Integrated sensors and shock absorbers • Suitable drive packages (stepper and servo motor technology)
→ Page/online	dhsl

Planar surface gantries

	
Type	Planar surface gantry EXCM
Size	10, 30
Stroke of the X-axis	90 ... 700 mm
Stroke of the Y-axis	110 ... 360 mm
Effective load at max. dynamic response	0.5 kg, 2/3 kg (vertical/horizontal mounting position)
Max. acceleration	3 ... 10 m/s ²
Description	<ul style="list-style-type: none"> • Excellent functionality in a very small fitting space • Small moving loads • Actuation via two stepper motors with integrated optical encoder and two-axis controller • EXCM-30 with flexible motor mounting • With plain or recirculating ball bearing guide
→ Page/online	excm

6

Three-dimensional gantries

	
Type	Three-dimensional gantry DHSR
Effective load	0 ... 50 kg
X-stroke	0 ... 8,500 mm
Y-stroke	0 ... 2,000 mm
Z-stroke	0 ... 1,000 mm
Description	<ul style="list-style-type: none"> • Different variants consisting of linear drives and slide drives • Electric and pneumatic actuation • Integrated sensors • Suitable drive packages (stepper and servo motor technology)
→ Page/online	dhsr

Tripods

	
Type	Tripod EXPT
Max. effective load	5 kg
Working space nominal diameter	450 ... 1,200 mm
Working space nominal height	100 mm
Max. picking rate	150 picks/min in 12" cycle
Description	<ul style="list-style-type: none"> • Low moving mass – ideal for high demands on dynamic response in three dimensions • Great path accuracy with a range of path profiles, even for very dynamic operation
→ Page/online	expt

Note

Control cabinets for controllers in handling systems → Page 1004



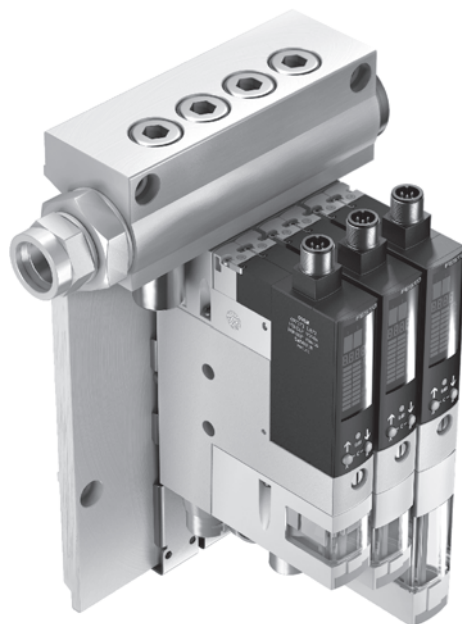

7 Vacuum technology

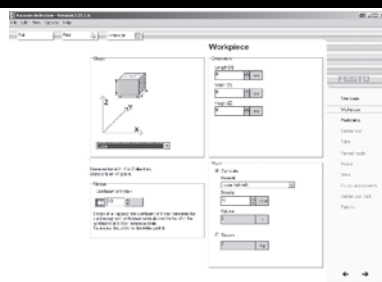

Software tool





<p>Vacuum selection</p> 	<p>Which suction cup for which surface and which movement? Don't experiment – calculate! This software tool even enables a differentiation to be made between linear and rotary movements.</p>	<p>This tool can be found</p> <ul style="list-style-type: none"> • in the electronic catalogue via the blue icons in the product tree underneath the search field, or • on the website under Support in the Engineering software area, or • on the DVD under Selection and sizing.
--	--	---

Vacuum generators

Type	 Vacuum generator, metric OVEM	 Vacuum generator, pneumatic VN, VN-P, VN-A	 Vacuum generator VAD	 Vacuum generator VAK
Nominal size of laval nozzle	0.45 ... 1.4 mm	0.45 ... 3 mm	0.5 ... 1.5 mm	1 mm
Ejector characteristics	Standard, high suction rate, high volume	Inline, standard, high suction rate, high volume	High vacuum	High vacuum
Integrated function	Electric ejector pulse valve, flow control valve, electric on-off valve, filter, electric air economy circuit, non-return valve, open silencer, vacuum switch	Pneumatic ejector pulse, open silencer, vacuum switch		Pneumatic ejector pulse
Max. vacuum	93%	86 ... 93%	80%	80%
Max. suction rate with respect to atmosphere	6 ... 50.5 l/min	6.1 ... 339 l/min		
Description	<ul style="list-style-type: none"> • Compact design • Monitoring and visualisation of the vacuum by means of vacuum sensor with LCD display • Central electrical connection via an M12 plug • Maintenance-free operation and reduced noise level through an integrated, open silencer • Integrated filter with inspection window for maintenance display • Adjustable ejector pulse 	<ul style="list-style-type: none"> • Can be used directly in the work space • Available as straight type (inline: vacuum port in line with supply port) or T-shape (standard: vacuum port at 90° to supply port) • Cost-effective • No wearing parts • Optional with vacuum switch (-P) • Optional with ejector pulse (-A) 	<ul style="list-style-type: none"> • Sturdy aluminium housing • Connection for additional external reservoir • Maintenance-free • See product documentation on our website for max. suction rate 	<ul style="list-style-type: none"> • Sturdy aluminium housing • Connection for additional external reservoir • Built-in reservoir • Reliable setting down of workpieces • See product documentation on our website for max. suction rate
→ Page/online	ovem	vn	vad	vak

7





Vacuum generators

				
Type	Vacuum generator, electro-pneumatic VN-M, VN-B	Vacuum generator VADM, VADMI	Vacuum generator VAD-M, VAD-M-I	Vacuum generator for valve terminal CPV CPV10-M1H, CPV14-M1H, CPV18-M1H
Nominal size of laval nozzle	0.45 ... 3 mm	0.45 ... 3 mm	0.7 ... 2 mm	0.7 ... 1.4 mm
Ejector characteristics	Standard, high suction rate, high volume	High vacuum	High vacuum	High vacuum
Integrated function	Pneumatic ejector pulse, electric on-off valve	Electric ejector pulse valve, flow control valve, electric on-off valve, filter, electric air economy circuit, non-return valve, vacuum switch	Electric ejector pulse valve, electric on-off valve	
Max. vacuum	92 ... 93%	85%	85 ... 90%	85%
Max. suction rate with respect to atmosphere	7.2 ... 186 l/min			
Description	<ul style="list-style-type: none"> • Can be used directly in the work space • Available as straight type (inline: vacuum port in line with supply port) or T-shape (standard: vacuum port at 90° to supply port) • Cost-effective • No wearing parts • With solenoid valve for vacuum ON/OFF • Integrated vacuum switch 	<ul style="list-style-type: none"> • Compact and sturdy design • Integrated solenoid valve (On/off) • Filter with contamination indicator • Available with air economy circuit, vacuum switch • Reliable setting down of workpieces • See product documentation on our website for max. suction rate 	<ul style="list-style-type: none"> • Compact and sturdy design • Integrated solenoid valve (On/off) • Reliable setting down of workpieces • Maintenance-free because there are no moving parts 	<ul style="list-style-type: none"> • Combinations with a number of vacuum generators are possible on the same valve terminal • With solenoid valve for vacuum ON/OFF • With or without ejector pulse
→ Page/online	vn	vadm	vad-m	cpv10-m1h



Vacuum generators

	
Type	Vacuum generator cartridge VN
Nominal size of laval nozzle	0.45 ... 2 mm
Ejector characteristics	Standard, high suction rate, high volume
Integrated function	
Max. vacuum	92... 93%
Max. suction rate with respect to atmosphere	7.2 ... 184 l/min
Description	<ul style="list-style-type: none"> • For fitting into customised housing for decentralised vacuum generation
→ Page/online	vn





Vacuum gripping technology

				
Type	Bernoulli gripper OGGB	Suction gripper ESG	Suction cup holder ESH	Suction cup ESS
Suction cup size		10x30 mm, 15x45 mm, 20x60 mm, 25x75 mm, 30x90 mm, 4x10 mm, 4x20 mm, 6x10 mm, 6x20 mm, 8x20 mm, 8x30 mm		10x30 mm, 15x45 mm, 20x60 mm, 25x75 mm, 30x90 mm, 4x10 mm, 4x20 mm, 6x10 mm, 6x20 mm, 8x20 mm, 8x30 mm
Suction cup diameter	60 mm, 100 mm, 140 mm	2 ... 200 mm		2 ... 200 mm
Breakaway force at 70% vacuum		0.1 ... 1,610 N		0.1 ... 1,610 N
Design		Oval, standard, round, bellows 1.5 convolutions, round, bellows 3.5 convolutions, round, bell-shaped, round, standard, round, extra-deep	Vacuum port on top, vacuum port on side, with height compensator	Bellows, oval, standard, round, bellows 1.5 convolutions, round, bellows 3.5 convolutions, round, bell-shaped, round, standard, round, extra-deep
Information on materials Suction cup	POM, NBR	FPM, NBR, PUR, TPE-U(PU), VMQ (silicone)		FPM, NBR, PUR, TPE-U(PU), VMQ (silic- one)
Description	<ul style="list-style-type: none"> Ideally suited to transporting thin, extremely delicate and brittle workpieces Minimised workpiece contact, gentle workpiece handling Low energy costs thanks to minimised air consumption Minimal assembly and installation 	<ul style="list-style-type: none"> Modular system of suction cup holder and suction cup with over 2,000 variants Available with angle compensator, height compensator, filter 15 suction cup diameters 5 suction cup shapes Suction cup volume: 0.002 ... 245 cm³ Min. workpiece radius: 10 ... 680 mm Vacuum port: push-in connector or barbed fitting for plastic tubing, threaded connection 	<ul style="list-style-type: none"> With or without height compensator 6 holder sizes 8 holder types 3 tubing connections 	<ul style="list-style-type: none"> Suction cup consisting of the suction cup itself, plus the support plate with mounting Suction cup volume: 0.002 ... 245 cm³ Min. workpiece radius: 10 ... 680 mm Mounting for suction cup holder: female thread, male thread, push-in connector
→ Page/online	oggb	esg	esh	ess





Vacuum gripping technology

		
Type	Suction cup ESV	Suction cup VAS, VASB
Suction cup size		
Suction cup diameter	20 ... 200 mm	2 ... 125 mm
Breakaway force at 70% vacuum	9.8 ... 1,610 N	0.14 ... 606 N
Design	Bellows, round, bellows 1.5 convolutions, round, bellows 3.5 convolutions, round, bell-shaped, round, standard, round, extra-deep	Vacuum port on top, vacuum port on side, round, bellows 1.5 convolutions, round, standard
Information on materials Suction cup	FPM, NBR, PUR, TPE-U(PU), VMQ (silicone)	NBR, PUR, TPE-U(PU), VMQ (silicone)
Description	<ul style="list-style-type: none"> Suction cup wearing part Easily interchangeable Suction cup volume: 0.318 ... 245 cm³ Min. workpiece radius: 10 ... 680 mm 	<ul style="list-style-type: none"> Sturdy and reliable Suction cups with fixed connecting thread 11 suction cup diameters Round suction cup shape, bellows Vacuum port on top, at side Free of copper, PTFE and silicone Screw-in thread
→ Page/online	esv	vas

Accessories for vacuum

				
Type	Silencer UO/UOM Silencer extension UOMS	Vacuum security valve ISV	Vacuum gauge VAM/FVAM	Vacuum filter VAF
Description	<ul style="list-style-type: none"> • For vacuum generator VN • Facilitates trouble-free operation of the vacuum generator 	<ul style="list-style-type: none"> • For maintaining the vacuum when using multiple suction cups and one fails • Gripping of randomly placed products 	<ul style="list-style-type: none"> • EN 837-1 • Optionally with red/green range • Analogue display • For front panel mounting 	<ul style="list-style-type: none"> • Vacuum port PK-3, PK-4, PK-6 • Grade of filtration 50 µm
→ Page/online	uo	isv	vam	vaf

Accessories for vacuum

				
Type	Height compensator VAL	Filter ESF	Elbow fitting LJK	Angle compensator ESWA
Description	<ul style="list-style-type: none"> • Vacuum port M5, G1/8, G1/4 	<ul style="list-style-type: none"> • Vacuum port M4x0.7, M6x1 • Grade of filtration 10 µm 	<ul style="list-style-type: none"> • Vacuum port M5, G1/8, G1/4 	<ul style="list-style-type: none"> • Vacuum port M4x0.7, M6x1, M10x1.5
→ Page/online	val	esf	ljk	eswa

Accessories for vacuum



	
Type	Adapter AD
Description	<ul style="list-style-type: none"> • Vacuum port M5, G1/8, G1/4, G3/8
→ Page/online	ad

7

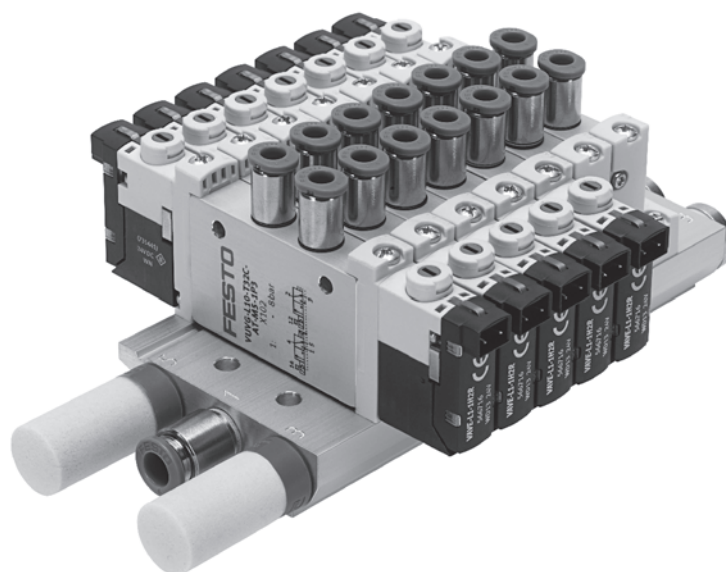

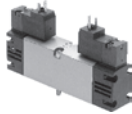

8 Valves







Standard directional control valves

Type	 Standard valve with round plug VSVA-R5, VSVA-R2	 Standard valve with square plug VSVA-C1	 Standard valve for valve terminal VTSA/VTSA-F VSVA-T1	 Pneumatic valve, to ISO 15407-1 VSVA
Actuation type	Electric	Electric	Electric	Pneumatic
Pneumatic connection 1	Sub-base size 1 to ISO 5599-1, G1/4, sub-base size 2 to ISO 5599-1, G3/8 Sub-base size 26 mm to ISO 15407-1, sub-base size 01 to VDMA 24563, G1/4 Sub-base size 18 mm to ISO 15407-1, sub-base size 02 to VDMA 24563	Sub-base size 26 mm to ISO 15407-1, sub-base size 18 mm to ISO 15407-1	Sub-base size 1 to ISO 5599-2, sub-base size 2 to ISO 5599-2, sub-base size 18 mm to ISO 15407-2, sub-base size 26 mm to ISO 15407-2	Sub-base size 18 mm to ISO 15407-1, sub-base size 26 mm to ISO 15407-1
Standard nominal flow rate	400 ... 2,800 l/min	400 ... 1,100 l/min	400 ... 2,900 l/min	400 ... 1,100 l/min
Valve function	5/2-way, double solenoid, 5/2-way, double solenoid, dominant, 5/2-way, single solenoid, 5/3-way, closed, 5/3-way, exhausted, 5/3-way, pressurised, 2x3/2-way, single solenoid, closed, 3/2-way, single solenoid, open/closed, 2x3/2-way, single solenoid, open/closed, 2x3/2-way, single solenoid, open	5/2-way, double solenoid, 5/2-way, double solenoid, dominant, 5/2-way, single solenoid, 5/3-way, closed, 5/3-way, exhausted, 5/3-way, pressurised, 2x3/2-way, single solenoid, closed, 2x3/2-way, single solenoid, open/closed, 2x3/2-way, single solenoid, open	5/2-way, single solenoid, 5/2-way, double solenoid, 5/2-way, double solenoid, dominant, 5/3-way, port 2 pressurised, 4 exhausted, 5/3-way, closed, 5/3-way, exhausted, 5/3-way, pressurised 1 to 2, 4 to 5 closed, 5/3-way, pressurised, 2x2/2-way, single solenoid, closed, 2x3/2-way, single solenoid, closed, 2x3/2-way, single solenoid, open, 2x3/2-way, single solenoid, open/closed	2x3/2-way, monostable, closed, 2x3/2-way, monostable, open, 2x3/2-way, monostable, open/closed, 5/2-way, bistable, 5/2-way, bistable, dominant, 5/2-way, monostable, 5/3-way, pressurised, 5/3-way, exhausted, 5/3-way, closed
Electrical connection	3-pin, 4-pin, M12x1, M8x1, round design, central plug	Type C, with protective earth conductor, to DIN EN 175301-803, to EN 175301-803, without protective earth conductor	2-pin, 4-pin, to ISO 15407-2, to ISO 5599-2, plug	
Description	<ul style="list-style-type: none"> High-performance valves in sturdy metal housing Manifold assembly with mixed sizes possible Wide range of vertical stacking modules: pressure regulator plate, flow control plate, vertical pressure shut-off plate, etc. 	<ul style="list-style-type: none"> High-performance valves in sturdy metal housing Manifold assembly with mixed sizes possible Wide range of vertical stacking modules: pressure regulator plate, flow control plate, vertical pressure shut-off plate, etc. 	<ul style="list-style-type: none"> High-performance valves in sturdy metal housing 	<ul style="list-style-type: none"> Sturdy metal design Manifold assembly with mixed sizes possible Wide range of vertical stacking modules: pressure regulator plate, flow control plate, vertical pressure shut-off plate, etc.
→ Page/online	533	533	vtsa	533





Standard directional control valves

				
Type	Solenoid valve, to ISO 5599-1 MN1H, MFH, MDH, MEBH, MDH, JMN1H, JMN1DH, JMFH, JMFHD, JMDH, JMEBH, JMEBDH, JMDDH	Pneumatic valve, to ISO 5599-1 VL, J, JD	Standard valves to ISO 15218 (CNOMO) MD, MDH, MGXDH, MGXIAH, VSCS	Solenoid valve, to NAMUR (VDI/VDE 3845) NVF3, MFH, MN1H, MGTBH, VSNB
Actuation type	Electric	Pneumatic	Electric	Electric
Pneumatic connection 1	Sub-base, sub-base size 1 to ISO 5599-1, sub-base size 2 to ISO 5599-1, sub-base size 3 to ISO 5599-1, sub-base size 4 to ISO 5599-1	Sub-base size 1 to ISO 5599-1, sub-base size 2 to ISO 5599-1, sub-base size 3 to ISO 5599-1, sub-base size 4 to ISO 5599-1	Sub-base	Sub-base, G1/4
Standard nominal flow rate	1,100 ... 6,000 l/min	1,200 ... 6,000 l/min	13 ... 50 l/min	400 ... 1,000 l/min
Valve function	5/2-way, double solenoid, 5/2-way, double solenoid, dominant, 5/2-way, single solenoid, 5/3-way, pressurised, 5/3-way, exhausted, 5/3-way, closed	5/2-way, bistable, 5/2-way, bistable, dominant, 5/2-way, monostable, 5/3-way, pressurised, 5/3-way, exhausted, 5/3-way, closed	3/2-way, single solenoid, closed	5/2-way, double solenoid, 5/2-way and 3/2-way, single solenoid, 5/2-way, single solenoid, 5/2-way or 3/2-way, single solenoid
Electrical connection	Type A, M12x1, plug, central plug, to DIN 43650, round design, square design		Type A, type C, M12x1, to DIN EN 175301-803, to IEC 61076-2-101	Socket, type A, M20x1.5, to DIN 43650, to DIN EN 175301-803, screw terminal, plug, square design
Description	<ul style="list-style-type: none"> Sturdy metal design ISO size 1, 2, 3 and 4 Manifold assembly with mixture of ISO sizes 1/2/3 possible Extensive range of electrical connection options Wide range of vertical stacking modules: pressure regulator plate, flow control plate, vertical pressure shut-off plate, etc. Also available as a valve terminal 	<ul style="list-style-type: none"> Sturdy metal design ISO size 1, 2, 3 and 4 Individual assembly, manifold assembly 	<ul style="list-style-type: none"> CNOMO port pattern, to ISO 15218 Pilot valve with and without manual override 	<ul style="list-style-type: none"> Port pattern to NAMUR Direct mounting on drives Optional variants for use in Ex zone I Flat design
→ Page/online	549	iso 5599-1	iso 15218	namur

Universal directional control valves



				
Type	Pneumatic valve VUWG	Solenoid valve VUVG	Solenoid valve VUVB	Solenoid valve CPE10, CPE14, CPE18, CPE24
Actuation type	Pneumatic	Electric	Electric	Electric
Pneumatic connection 1	G1/8, M3, M5, M7	G1/4, G1/8, M3, M5, M7	Sub-base, QS4, QS-6, QS-8, QS10	G1/8, G1/4, G3/8, M5, M7, QS-4, QS-6, QS-8, QS-10, QS-12
Standard nominal flow rate	90 ... 780 l/min	80 ... 1,380 l/min	200 ... 1,000 l/min	180 ... 3,200 l/min
Valve function	2x3/2-way, monostable, closed, 2x3/2-way, monostable, open, 2x3/2-way, monostable, open/closed, 5/2-way, bistable, 5/2-way, monostable, 5/3-way, pressurised, 5/3-way, exhausted, 5/3-way, closed	2x3/2-way, single solenoid, closed, 2x3/2-way, single solenoid, open, 2x3/2-way, single solenoid, open/closed, 5/2-way, double solenoid, 5/2-way, single solenoid, 5/3-way, pressurised, 5/3-way, exhausted, 5/3-way, closed	3/2-way, single solenoid, closed, 3/2-way, single solenoid, open, 4/2-way, double solenoid, 4/2-way, single solenoid	3/2-way, single solenoid, closed, 3/2-way, single solenoid, open, 5/2-way, double solenoid, 5/2-way, single solenoid, 5/3-way, pressurised, 5/3-way, exhausted, 5/3-way, closed
Electrical connection		Via sub-base, via E-box	Type C, plug-in for multi-pin plug, plug, to EN 175301-803, via sub-base	2-pin, 4-pin, type C, M8x1
Description	<ul style="list-style-type: none"> Compact universal valve Easy mounting High flow rate relative to its size Can be mounted as an individual valve or sub-base valve on a sturdy aluminium manifold rail Individual valve of the VG series 	<ul style="list-style-type: none"> Compact Easy mounting Wide choice of variants High flow rate relative to its size Individual valve of the VG series 	<ul style="list-style-type: none"> In-line valve Semi in-line valve Sub-bases for individual valves Manifold rail for valve manifold with individual electrical connection or for valve terminal with electrical multi-pin connection 	<ul style="list-style-type: none"> High flow rate relative to its size Wide range of functions Comprehensive valve range
→ Page/online	vuwg	570	vuvb	cpe

Universal directional control valves

				
Type	Solenoid valve VMPA1, VMPA2	Solenoid valve CPASC1, CPPSC1	Solenoid valve, pneumatic valve, Tiger 2000 MFH, MVH, JMFH, JMVH, VL, J	Solenoid valve, pneumatic valve, Tiger Classic MFH, MOFH, JMFH, JMFH, VL/O, VL, JH, JDH
Actuation type	Electric	Electric	Electric, pneumatic	Electric, pneumatic
Pneumatic connection 1	G1/8, M7	Sub-base	Sub-base, G1/4, G1/8, G3/8	Sub-base, G1/2, G1/4, G1/8, G3/4
Standard nominal flow rate	360 ... 700 l/min	100 ... 220 l/min	700 ... 2,600 l/min	500 ... 7,500 l/min
Valve function	2x2/2-way, single solenoid, closed, 2x3/2-way, single solenoid, closed, 2x3/2-way, single solenoid, open, 2x3/2-way, single solenoid, open/ closed, 3/2-way, single solenoid, closed, 3/2-way, single solenoid, open, 5/2-way, double solenoid, 5/2-way, single solenoid, 5/3-way, pressurised, 5/3-way, exhausted, 5/3-way, closed	2x2/2-way, single solenoid, closed, 2x3/2-way, single solenoid, closed, 2x3/2-way, single solenoid, open, 3/2-way, single solenoid, closed, 5/2-way, double solenoid, 5/2-way, single solenoid, 5/3-way, pressurised, 5/3-way, exhausted, 5/3-way, closed	5/2-way, double solenoid/bistable, 5/2-way, single solenoid/monostable, closed, 5/2-way, single solenoid/mono- stable, 5/3-way, pressurised, 5/3-way, exhausted, 5/3-way, closed	3/2-way, single solenoid/monostable, closed, 3/2-way, single solenoid/mono- stable, open, 5/2-way, double solenoid/ bistable, 5/2-way, double solenoid/ bistable, dominant, 5/2-way, single solenoid/monostable, closed, 5/2-way, single solenoid/monostable, 5/3-way, pressurised, 5/3-way, exhausted, 5/3-way, closed
Electrical connection	4-pin, M8x1, plug	3-pin, plug	Type B, to EN 175301-803, via F coil, to be ordered separately	Via F coil, to be ordered separately
Description	<ul style="list-style-type: none"> • Supplements the valve terminals MPA • Mounted on individual sub-base • Comprehensive valve range 	<ul style="list-style-type: none"> • Wide choice of variants • Comprehensive valve range 	<ul style="list-style-type: none"> • Sturdy and reliable • Wide range of voltages 	<ul style="list-style-type: none"> • Sturdy and reliable • Wide range of voltages • All-metal valve
→ Page/online	vmpa1	cpasc1	tiger 2000	596

8





Universal directional control valves

			
Type	Solenoid valve, pneumatic valve, midi pneumatic MEBH, MOEBH, MEH, MOEH, JMEBH, JMEH, VL, J	Cassette valve C, CJ, CJM, CL, CM	Solenoid valves supplementary range BMCH, BMFH, JMC, JMF, MC, MCH, ME, MFH, MLC, MOCH, MOFH
Actuation type	Electric, pneumatic	Electric, pneumatic	Electric
Pneumatic connection 1	Sub-base, G1/8	Sub-base, G1/4, G1/2	Sub-base, M5, G1/8, G1/4, G1/2, G3/8, G3/4
Standard nominal flow rate	200 ... 700 l/min	1,400 l/min	46 ... 7,500 l/min
Valve function	3/2-way, single solenoid/monostable, closed, 3/2-way, single solenoid/monostable, open, 5/2-way, double solenoid/bistable, 5/2-way, single solenoid/ monostable, 5/3-way, pressurised, 5/3-way, exhausted, 5/3-way, closed	5/2-way, double solenoid/bistable, 5/2-way, single solenoid/monostable	2/2-way, single solenoid, closed, 2x3/2-way, single solenoid, closed, 3/2-way, single solenoid, closed, 3/2-way, single solenoid, open, 3x3/2-way, single solenoid, closed, 4/2-way, double solenoid, 4/2-way, single solenoid, 5/2-way, single solenoid, 5/3-way, pressurised, 5/3-way, exhausted, 5/3-way, closed, 5/4-way, closed
Electrical connection	Plug, square design to EN 175301-803, type C		Plug, via F coil, to be ordered separately
Description	<ul style="list-style-type: none"> • Semi in-line valve • Sub-base valve • Midi pneumatic: 18 mm width • Manifold assembly for 2 ... 10 valves or individual mounting • Operating voltage 24 V DC, 110/230 V AC (50 ... 60 Hz) 	<ul style="list-style-type: none"> • Sturdy • For direct mounting on sub-base • With and without manual override 	<ul style="list-style-type: none"> • With and without manual override • Manifold mounting or individual valve • Valves MC are especially suitable for positioning, for stopping in the event of an emergency-stop and for holding double-acting cylinders in any position
→ Page/online	mebh	cm	bmch



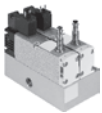

Universal directional control valves

		
Type	Pneumatic valves supplementary range A, VL	Basic valve LC
Actuation type		Pneumatic, electric
Pneumatic connection 1	G1/4, G3/8, PK-3	G1/8, G1/4
Standard nominal flow rate	105 ... 1,800 l/min	80 ... 600 l/min
Valve function	5/2-way, bistable, 5/2-way, monostable, 8/2-way, monostable	3/2-way directly actuated, 5/4-way indirectly actuated
Electrical connection		
Description	<ul style="list-style-type: none"> For actuating cylinders for single stroke and oscillating movements For positioning, for stopping in the event of an emergency-stop and for holding double-acting cylinders in any position For controlling functions of pneumatic feed units such as feed motions and reciprocal clamping Actuation either manually by means of switch lever, mechanically by means of control stem or pneumatically 	<ul style="list-style-type: none"> Screw-in actuator attachments For positioning, for stopping in the event of an emergency-stop and for holding double-acting cylinders in any position
→ Page/online	vl	lc



Application-specific directional control valves

				
Type	Control block VOFA	Solenoid valve VOFD	Solenoid valve VOFC	Solenoid valve VOVG
Actuation type	Electric	Electric	Electric	Electric
Pneumatic connection 1	G1/4	G1/4, NPT1/4-18, NAMUR Port pattern	G1/2, G1/4, NPT1/4-18, NAMUR Port pattern	Sub-base M5, M7
Standard nominal flow rate	950 l/min	450 l/min	450 ... 3,000 l/min	180 ... 200 l/min
Valve function	5/2-way, single solenoid	3/2-way, single solenoid, closed	3/2-way, single solenoid, closed, 5/2-way, double solenoid, 5/2-way, single solenoid	3/2-way, single solenoid, closed, 3/2-way, single solenoid, open, 5/2-way, single solenoid
Electrical connection	Type C, to EN 175301-803, without protective earth conductor	Terminal box, cable entry thread M20x1.5	Terminal box, cable entry thread M20x1.5	2-pin, plug
Description	<ul style="list-style-type: none"> Can be used as a press safety valve for safe reversing of a hazardous movement Can be selected as a decentralised individual connection variant with electrical and pneumatic individual connection or as a feature integrated in the valve terminal VTSA/VTSA-F Sturdy and durable metal design Designed as a purely mechanical solution with regard to safety 	<ul style="list-style-type: none"> Ideally suited to the area of process automation, for use in chemical and petrochemical plants Robust design Excellent corrosion resistance Especially suitable for quarter turn actuators thanks to NAMUR flange pattern 	<ul style="list-style-type: none"> For outdoor use under harsh ambient conditions, e.g. in refineries thanks to sturdy design and high corrosion resistance Piloted piston spool and piston poppet valves In-line valve Variants with TÜV approval up to SIL4 to IEC 61508 Shuttle valve can switch between internal and external pilot air 	<ul style="list-style-type: none"> For compact handling applications or for solutions requiring an extremely high component density For applications in the electronics and light assembly industries In-line valve Semi in-line valve Sub-base valve Direct mounting, manifold assembly Manifold rail for 2 ... 10 valves Width 10, 12, 25 mm Operating voltage 5, 12 or 24 V DC
→ Page/online	vofa	vofd	vofc	vovg



Application-specific directional control valves

				
Type	Solenoid valve MHA1, MHP1	Solenoid valve MHE2, MHP2, MHA2, MHE3, MHP3, MHA3, MHE4, MHP4, MHA4	Solenoid valve CDVI5.0	Solenoid valve MHJ9, MHJ10
Actuation type	Electric	Electric	Electric	Electric
Pneumatic connection 1	Sub-base, QS-3, QS-4, prepared for QSP10	Sub-base, G1/4, G1/8, M7, QS-4, QS-6, QS-8	Sub-base	Sub-base, QS-4, QS-6
Standard nominal flow rate	10 ... 30 l/min	90 ... 400 l/min	300 ... 650 l/min	50 ... 160 l/min
Valve function	2/2-way, single solenoid, closed, 2x2/2-way, single solenoid, closed, 3/2-way, single solenoid, closed, 3/2-way, single solenoid, open	3/2-way, single solenoid, closed, 3/2-way, single solenoid, open, 5/2-way, single solenoid	2/2-way, single solenoid, closed, 2/2-way, single solenoid, open, 2x3/2-way, single solenoid, closed, 2x3/2-way, single solenoid, open, 3/2-way, single solenoid, closed, 3/2-way, single solenoid, open, 5/2-way, double solenoid, 5/2-way, single solenoid, 5/3-way, pressurised, 5/3-way, exhausted, 5/3-way, closed	2/2-way, single solenoid, closed
Electrical connection	Plug	2-pin, cable, plug	10 m cable	2-pin, 3-wire, cable, plug
Description	<ul style="list-style-type: none"> Semi in-line valve Sub-base valve Miniature valve: grid dimension 10 mm Sub-bases Manifold block for 2 ... 10 valves Switching times down to 4 ms Operating voltage 5, 12 or 24 V DC 	<ul style="list-style-type: none"> In-line valve Semi in-line valve Sub-base valve Fast-switching valve: switching times down to 2 ms Direct mounting, individual sub-base, manifold assembly Manifold block for 2 ... 10 valves Grid dimension 14, 19, 24 mm Operating voltage 24 V DC 	<ul style="list-style-type: none"> Sub-base valve Corrosion-resistant Easy-to-clean design Also available as valve terminal CDVI Operating voltage 24 V DC 	<ul style="list-style-type: none"> Sub-base valve Individual valve with integrated QS fitting For very fast sorting applications with up to 1,000 Hz Very long service life > 2 billion switching cycles Outstanding reproducibility
→ Page/online	mh1	mh2	cdvi5.0	Mhj9





Application-specific directional control valves

		
Type	Pneumatic and solenoid valves, M5 Compact System J, JD, JMFH, MFH, MUFH, VD, VL/O, VL	Valve for pneumatic feed unit BV MLC-8, VL-8
Actuation type		Electric, pneumatic
Pneumatic connection 1	PK-3, sub-base	G3/8
Standard nominal flow rate	50 ... 105 l/min	1,800 l/min
Valve function	3/2-way, double solenoid/bistable, 3/2-way, single solenoid/monostable, closed, 3/2-way, single solenoid/monostable, open, 5/2-way, double solenoid/bistable, 5/2-way, double solenoid/bistable, dominant, 5/2-way, single solenoid/ monostable	8/2-way, single solenoid/monostable
Electrical connection		
Description	<ul style="list-style-type: none"> Complete system offering control components with all the functions required for pneumatic sequence controls For control cabinet installation Fast replacement of components 	<ul style="list-style-type: none"> For controlling feed motion and reciprocal clamping in pneumatic feed units
→ Page/online	m5 compact	mlc



Manually actuated directional control valves: Swivel lever valves

		
Type	Hand lever valve VHER	Hand lever valve H-3-1/4-B, H-5-1/4-B
Valve function	4/3-way exhausted, 4/3-way closed	3/2-way monostable, 5/2-way bistable
Type of control	Direct	Direct, piloted
Standard nominal flow rate	170 ... 4,300 l/min	550 ... 600 l/min
Pneumatic working port	G1/2, G1/4, G1/8, M5	G1/4
Operating pressure	-0.95 ... 10 bar	-0.95 ... 10 bar
Description	<ul style="list-style-type: none"> • With lever and detent • Lever in metal or polymer design • Front panel mounting, through or mounting holes • Can also be used as 3/3-way valve by sealing port 2 	<ul style="list-style-type: none"> • With hand lever • Die-cast aluminium design
→ Page/online	vher	n_v14





Manually actuated directional control valves: Pushbutton valves

				
Type	Pushbutton valve VHEM-P	Pushbutton valve K/O-3-PK	Pushbutton valve K-3-M5	Pushbutton valve T-5/3-1/4
Valve function	5/2-way, bistable, 5/2-way, monostable, 3/2-way, bistable, 3/2-way, monostable, closed, 3/2-way, monostable, open	3/2-way, monostable, open/closed	3/2-way, monostable, closed	5/3-way, closed
Type of control	Direct, piloted	Direct	Direct	Piloted
Standard nominal flow rate	500 l/min, 1,000 l/min	80 l/min	80 l/min	680 l/min
Pneumatic working port	G1/8, G1/4	PK-3	M5	G1/4
Operating pressure	-0.95 ... 10 bar	0 ... 8 bar	-0.95 ... 8 bar	2 ... 10 bar
Description	<ul style="list-style-type: none"> • With button switch • Reverse operation possible • Fast assembly 	<ul style="list-style-type: none"> • With button switch • Polymer design • Ducted exhaust air 	<ul style="list-style-type: none"> • With button switch • Suitable for vacuum operation • Sturdy die-cast zinc design 	<ul style="list-style-type: none"> • With pushbutton • For positioning, for stopping in the event of an emergency-stop and for holding a double-acting cylinder in any position • Aluminium design
→ Page/online	vhem-p	n_vpk	k-3	n_msv



Manually actuated directional control valves: Pushbutton valves

		
Type	Heavy-duty palm button valve PV-3-1/8	Pushbutton valve F-3-M5
Valve function	3/2-way, monostable, closed	3/2-way, monostable, closed
Type of control	Direct	Direct
Standard nominal flow rate	80 l/min	80 l/min
Pneumatic working port	G1/8	M5
Operating pressure	-0.95 ... 8 bar	-0.95 ... 10 bar
Description	<ul style="list-style-type: none"> • With large actuating surface • For heavy-duty actuation • Suitable for vacuum operation 	<ul style="list-style-type: none"> • With pedal • Suitable for vacuum operation • Sturdy die-cast zinc design
→ Page/online	pv-3	f-3-m5



Manually actuated directional control valves: Finger lever valves

Type	 Finger lever valve VHEM-L, VHEM-LT	 Finger lever valve TH/O-3-PK-3	 Finger lever valve TH-3-M5, TH-3-1/4-B, TH-5-1/4-B, THO-3-1/4-B	 Finger lever valve H-4/3
Valve function	3/2-way, monostable, closed, 3/2-way, monostable, open, 5/2-way, monostable	3/2-way, monostable, closed	3/2-way, monostable, closed, 3/2-way, monostable, open, 5/2-way, monostable	4/3-way exhausted, 5/3-way closed
Type of control	Direct	Direct	Direct	Piloted
Standard nominal flow rate	500 l/min, 1,000 l/min	80 l/min	80 ... 600 l/min	125 l/min
Pneumatic working port	G1/8, G1/4	PK-3	G1/4, M5	M5
Operating pressure	-0.95 ... 10 bar	0 ... 8 bar	-0.95 ... 10 bar	0 ... 8 bar
Description	<ul style="list-style-type: none"> • With finger lever • Mechanical spring return • Fast assembly 	<ul style="list-style-type: none"> • With finger lever • Polymer design • Ducted exhaust air 	<ul style="list-style-type: none"> • With finger lever • Die-cast zinc or die-cast aluminium design 	<ul style="list-style-type: none"> • With detenting finger lever • Front panel mounting or mounting on sub-base • Aluminium design
→ Page/online	vhem-l	n_vpk	th-3-m5	h-4

Manually actuated directional control valves: Toggle lever valves

Type	 Toggle lever valve KH/O-3-PK-3	 Toggle lever valve H-5/3-1/4
Valve function	3/2-way, monostable, open/closed	5/3-way, closed
Type of control	Direct	Piloted
Standard nominal flow rate	80 l/min	680 l/min
Pneumatic working port	PK-3	G1/4
Operating pressure	0 ... 8 bar	2 ... 10 bar
Description	<ul style="list-style-type: none"> • With toggle lever • Polymer design • Ducted exhaust air 	<ul style="list-style-type: none"> • With toggle lever • For positioning, for stopping in the event of an emergency-stop and for holding a double-acting cylinder in any position • Aluminium design
→ Page/online	n_vpk	n_msv



Manually actuated directional control valves: Foot valves

Type	 Foot valve F-3-1/4-B, FO-3-1/4-B, F-5-1/4-B	 Foot valve with detent FP-3-1/4-B, FPB-3-1/4, FP-5-1/4-B
Valve function	3/2-way, monostable, closed, 3/2-way, monostable, open, 5/2-way, monostable	3/2-way, monostable, closed, 5/2-way, monostable
Type of control	Direct	Direct
Standard nominal flow rate	550 ... 600 l/min	550 ... 600 l/min
Pneumatic working port	G1/4	G1/4
Operating pressure	-0.95 ... 10 bar	-0.95 ... 10 bar
Description	<ul style="list-style-type: none"> • With foot pedal • Sturdy die-cast zinc design 	<ul style="list-style-type: none"> • With foot pedal with detent • Sturdy die-cast zinc design
→ Page/online	fo-3	fpb-3

Manually actuated directional control valves: Selector switches

	
Type	Selector switch HW-6-38
Valve function	8/6-way, monostable
Type of control	Direct
Standard nominal flow rate	180 l/min
Pneumatic working port	M5
Operating pressure	0 ... 8 bar
Description	<ul style="list-style-type: none"> • With rotary knob and arrow • Front panel mounting or mounting on sub-base • With six switching positions
→ Page/online	hw-6



Manually actuated directional control valves: Front panel valves

			
Type	Front panel valve SV/O-3-PK-3x2	Front panel valve SVS-3-1/8, SVS-4-1/8, SVSO-3-1/8	Front panel valve SV-3-M5, SV-5-M5-B
Valve function	2x3/2-way, monostable, closed	3/2-way, monostable, closed, 3/2-way, monostable, open, 4/2-way, monostable	3/2-way, monostable, closed, 5/2-way, monostable
Type of control	Direct	Direct	Direct
Standard nominal flow rate	70 l/min	120 l/min	65 ... 95 l/min
Pneumatic working port	PK-3	G1/8	M5
Operating pressure	0 ... 8 bar	3.5 ... 8 bar	-0.95 ... 8 bar
Description	<ul style="list-style-type: none"> • Basic valve for actuator attachments such as toggle and selector switches • Polymer design • Reliable coupling system for rapid assembly and dismantling 	<ul style="list-style-type: none"> • Basic valve for actuator attachments such as pushbutton actuators, mushroom pushbuttons, mushroom actuators, selector switches, toggle levers, key actuators • Reliable coupling system for rapid assembly and dismantling • Front panel mounting 	<ul style="list-style-type: none"> • Basic valve for actuator attachments such as pushbutton actuators, mushroom pushbuttons, mushroom pushbuttons with detent, selector switches, toggle switches • Front panel mounting • Plastic design • Reliable coupling system for rapid assembly and dismantling
→ Page/online	sv	svos	sv-3



Mechanically actuated directional control valves: Stem actuated valves

				
Type	Stem actuated valve VMEM	Stem actuated valve V/O-3-PK-3, V/O-3-1/8	Stem actuated micro valve S-3-PK-3-B, SO-3-PK-3-B	Stem actuated valve VS-3-1/8, VS-4-1/8, VOS-3-1/8
Valve function	3/2-way, monostable, open/closed, 5/2-way, monostable	3/2-way, monostable, open/closed	3/2-way, monostable, closed, 3/2-way, monostable, open	3/2-way, monostable, closed, 3/2-way, monostable, open, 4/2-way, monostable
Type of control	Direct, piloted	Direct	Direct	Piloted
Standard nominal flow rate	500 l/min, 1,000 l/min	80 ... 140 l/min	60 l/min	120 l/min
Pneumatic working port	G1/8, G1/4	G1/8, PK-3	PK-3	G1/8
Operating pressure	-0.95 ... 10 bar	-0.95 ... 8 bar	-0.95 ... 8 bar	3.5 ... 8 bar
Description	<ul style="list-style-type: none"> • Outstanding pneumatic performance for a wide range of applications • Light weight • Small size • Versions: VMEM-S: stem actuated valve, VMEM-B: ball actuated valve, VMEM-D: roller actuated valve 	<ul style="list-style-type: none"> • With plunger or actuator attachments as required • Through-holes in housing • Polymer or aluminium design 	<ul style="list-style-type: none"> • With plunger for actuator attachments such as pushbutton actuators, toggle levers • Dimensions to DIN 41635, type A • Polymer design 	<ul style="list-style-type: none"> • With plunger • Aluminium design • Minimal actuating force with pilot control • Can also be used as a 2/2-way valve by plugging the exhaust
→ Page/online	vmem	n_v18	s-3-pk	vos



Mechanically actuated directional control valves: Stem actuated valves

			
Type	Stem actuated valve V-3-1/4-B, V-5-1/4-B, VO-3-1/4-B	Limit valve SDK-3-PK-3, SDK-4-PK-3	Limit stop signal generator SDV-2-B, SDV-3
Valve function	3/2-way, monostable, closed, 3/2-way, monostable, open, 5/2-way, monostable	3/2-way, monostable, closed	3/2-way, monostable, closed
Type of control	Direct	Direct	Direct
Standard nominal flow rate	550 ... 600 l/min	16 l/min	16 l/min
Pneumatic working port	G1/4	PK-3	PK-3
Operating pressure	-0.95 ... 10 bar	0 ... 8 bar	0 ... 8 bar
Description	<ul style="list-style-type: none"> • With plunger • Die-cast aluminium design 	<ul style="list-style-type: none"> • Can be used for stroke-dependent signal generation as a limit switch and fixed stop • For end-position sensing and position control • High accuracy • Stainless steel design 	<ul style="list-style-type: none"> • Can be used for stroke-dependent signal generation as a limit switch and fixed stop • For end-position sensing and position control • High precision and low actuating forces • Compact dimensions • Use in contaminated environments
→ Page/online	vo-3	sdk	sdv



Mechanically actuated directional control valves: Roller lever valves

			
Type	Roller lever valve R/O-3-PK-3	Roller lever valve RS-3-1/8, RS-4-1/8, ROS-3-1/8	Roller lever valve R-3-M5, R-3-1/4-B, R-5-1/4-B, RO-3-1/4-B
Valve function	3/2-way, monostable, open/closed	3/2-way, monostable, closed, 3/2-way, monostable, open, 4/2-way, monostable	3/2-way, monostable, closed, 3/2-way, monostable, open, 5/2-way, monostable
Type of control	Direct	Piloted	Direct
Standard nominal flow rate	80 l/min	120 l/min	80 ... 600 l/min
Pneumatic working port	PK-3	G1/8	G1/4, M5
Operating pressure	0 ... 8 bar	3.5 ... 8 bar	-0.95 ... 10 bar
Description	<ul style="list-style-type: none"> • With roller lever • Polymer design • Ducted exhaust air 	<ul style="list-style-type: none"> • With roller lever • Aluminium design • Minimal actuating force with pilot control • Can also be used as a 2/2-way valve by plugging the exhaust 	<ul style="list-style-type: none"> • With roller lever • Die-cast aluminium design
→ Page/online	n_vpk	ros-3	ro-3

Mechanically actuated directional control valves: Roller lever valves with idle return

			
Type	Roller lever valve with idle return L/O-3-PK-3	Roller lever valve with idle return LS-3-1/8, LS-4-1/8, LOS-3-1/8	Roller lever valve with idle return L-3-M5, L-3-1/4-B, L-4-1/4-B, LO-3-1/4-B
Valve function	3/2-way, monostable, open/closed	3/2-way, monostable, closed, 3/2-way, monostable, open, 4/2-way, monostable	3/2-way, monostable, closed, 3/2-way, monostable, open, 5/2-way, monostable
Type of control	Direct	Piloted	Direct
Standard nominal flow rate	80 l/min	120 l/min	80 ... 600 l/min
Pneumatic working port	PK-3	G1/8	G1/4, M5
Operating pressure	0 ... 8 bar	3.5 ... 8 bar	-0.95 ... 10 bar
Description	<ul style="list-style-type: none"> • With roller lever with idle return • Polymer design • Ducted exhaust air 	<ul style="list-style-type: none"> • With toggle lever • Aluminium design • Minimal actuating force with pilot control • Can also be used as a 2/2-way valve by plugging the exhaust 	<ul style="list-style-type: none"> • With roller lever • Die-cast aluminium design
→ Page/online	n_vpk	los-3	lo-3





Mechanically actuated directional control valves: Swivel lever valves

			
Type	Swivel lever valve RW/O-3-1/8	Pneumatic limit valve RWN/O-3-1/8-B	Swivel lever valve RW-3-M5
Valve function	3/2-way, monostable, open/closed	3/2-way, monostable, open/closed	3/2-way, monostable, closed
Type of control	Direct	Direct	Direct
Standard nominal flow rate	140 l/min	120 l/min	80 l/min
Pneumatic working port	G1/8	G1/8	M5
Operating pressure	-0.95 ... 8 bar	-0.95 ... 8 bar	-0.95 ... 8 bar
Description	<ul style="list-style-type: none"> • Basic valve for actuator attachments such as swivel lever short, long, swivel lever rod • Aluminium design 	<ul style="list-style-type: none"> • Directly actuated in one direction • Aluminium design 	<ul style="list-style-type: none"> • With swivel lever • Additional actuator attachments such as swivel lever short, long, swivel lever rod • Sturdy die-cast zinc design
→ Page/online	rw	rwn	rw-3



Mechanically actuated directional control valves: Whisker valves

	
Type	Whisker valve FVS-3-1/8, FVSO-3-1/8
Valve function	3/2-way, monostable, closed, 3/2-way, monostable, open
Type of control	Piloted
Standard nominal flow rate	120 l/min
Pneumatic working port	G1/8
Operating pressure	3.5 ... 8 bar
Description	<ul style="list-style-type: none"> • With whisker • Especially suitable for sensing dissimilar workpieces or workpieces not precisely in position • Aluminium design • Minimal actuating force with pilot control • Can also be used as a 2/2-way valve by plugging the exhaust
→ Page/online	fvs-3





Non-return valves and quick exhaust valves

Type	 Non-return valve VBNF	 Quick exhaust valve VBQF	 Non-return valve H, HA, HB	 Non-return valve, piloted HGL
Pneumatic connection 1	QS-6, QS-8	G1/8, G1/4, QS-6, QS-8	G1/8, G1/4, G3/8, G1/2, G3/4, M5, QS-4, QS-6, QS-8, QS-10, QS-12, R1/8, R1/4, R3/8, R1/2	G1/8, G1/4, G3/8, G1/2, M5, QS-4, QS-6, QS-8, QS-10, QS-12
Standard nominal flow rate			115 ... 2,230 l/min	
Standard flow rate exhaust 6->0 bar		1,300 ... 2,500 l/min		
Standard nominal flow rate pressurisation 6->5 bar		350 ... 960 l/min		
Standard nominal flow rate 1->2 (6-5)	260 ... 620 l/min		1,000 ... 5,900 l/min	130 ... 1,600 l/min
Operating pressure	0.2 ... 10 bar	0.5 ... 10 bar	-1 ... 12 bar	0.5 ... 10 bar
Description	<ul style="list-style-type: none"> Minimal height High flow rate Can be rotated horizontally through 360° in assembled state 	<ul style="list-style-type: none"> Minimal height High flow rate Improved noise emissions Available with and without silencer Available with ducted and unducted exhaust air 	<ul style="list-style-type: none"> Valve function: non-return Screw-in or in-line installation With connecting thread at both ends, push-in connector at both ends, thread/push-in connector 	<ul style="list-style-type: none"> Valve function: piloted non-return function Pneumatically piloted Screw-in with male thread Pilot air connection: M5, G1/8, G1/4, G3/8, QS-4
→ Page/online	vbnf	vbqf	h-qs	608





Non-return valves and quick exhaust valves

Type	 Manual override HAB	 Quick exhaust valve SE, SEU
Pneumatic connection 1	G1/8, G1/4, G3/8, G1/2	G1/8, G1/4, G3/8, G1/2, G3/4
Standard nominal flow rate		
Standard flow rate exhaust 6->0 bar	165 l/min	1,000 ... 6,500 l/min
Standard nominal flow rate pressurisation 6->5 bar		300 ... 4,560 l/min
Standard nominal flow rate 1->2 (6-5)		
Operating pressure	0 ... 10 bar	0.2 ... 10 bar
Description	<ul style="list-style-type: none"> Valve function: exhaust component For non-return valve HGL For manual exhausting of air trapped in a cylinder 	<ul style="list-style-type: none"> Valve function: quick exhaust Shut-off valve, piloted Screw-in With or without silencer
→ Page/online	hab	se



Ball valves and shut-off valves

Type	 Hand slide valve VBOH	 Shut-off valve HE	 Hand slide valve W	 Ball valve QH, QHS
Valve function		2/2-way bistable, 3/2-way bistable	3/2-way, bistable	2/2-way, bistable
Pneumatic connection 1	G1/8, G1/4, G1/2, G3/8, G3/4, M5	QS-6, QS-8, QS-10, QS-12, R1/8, R1/4, R3/8, R1/2	G1/8, G1/4, G3/8, G1/2, G3/4, M5	G1/4, G3/8, G1/2, G3/4, G1, G1 1/2, QS-4, QS-6, R1/8
Standard nominal flow rate	236 ... 7,691 l/min	270 ... 840 l/min	120 ... 6,800 l/min	148 ... 84,000 l/min
Operating pressure	-0.95 ... 12 bar	-0.95 ... 10 bar	-0.95 ... 10 bar	-1 ... 10 bar
Description	<ul style="list-style-type: none"> Used as a shut-off function for pressurising and exhausting compressed air systems, for example upstream of service unit combinations, for air guns and also for exhausting pneumatic cylinders Non-overlapping, so no pressure losses when switching Minimal installation 	<ul style="list-style-type: none"> Shut-off valve, piloted Connection: thread at both ends, push-in connector at both ends, thread/push-in connector 	<ul style="list-style-type: none"> Shut-off valve, manually actuated In-line installation Metal design 	<ul style="list-style-type: none"> Shut-off valve, manually actuated In-line installation, can be screwed in, bulkhead fitting Variants: thread at both ends, push-in connector at both ends, thread/push-in connector
→ Page/online	vboh	he	w-3	qh





Logic valves

Type	 NOT module OS	 Amplifier module VK	 NOT module VLO	 AND module ZK
Valve function	OR function			AND function
Pneumatic connection 1	G1/2, G1/4, G1/8, PK-3, PK-4	PK-4, M5	PK-4, M5	G1/8, PK-3, PK-4
Standard nominal flow rate	100 ... 5,000 l/min	80 l/min	80 l/min	100 ... 550 l/min
Operating pressure	0.001 ... 10 bar	0.1 ... 0.25 bar and 1 ... 7 bar	0.1 ... 0.25 bar and 1 ... 7 bar	0.001 ... 10 bar
Description	<ul style="list-style-type: none"> Valve function: OR function Logic valve Pneumatic control system Mounting via through-holes 	<ul style="list-style-type: none"> For pneumatic sensors 	<ul style="list-style-type: none"> For pneumatic sensors 	<ul style="list-style-type: none"> Valve function: AND function Dual-pressure valve Connects two input signals in the AND function Mounting via through-holes
→ Page/online	os	vk	vlo	zk

Pressure regulators

		
Type	Pressure regulator LR-QS, LRMA-QS	Differential pressure regulator LRL, LRLl
Pressure regulation range	1 ... 8 bar	2 ... 6 bar
Standard nominal flow rate	22 ... 150 l/min	
Nominal flow rate, closed		30 ... 730 l/min
Nominal flow rate, open		30 ... 760 l/min
Pneumatic connection 1	G1/8, G1/4, M5, QS-4, QS-6, QS-8	G1/8, G1/4, G3/8, G1/2, M5
Pneumatic connection 2	QS-4, QS-6, QS-8	QS-4, QS-6, QS-8, QS-10, QS-12
Description	<ul style="list-style-type: none"> • Piston regulator with through pressure supply • Available with pressure gauge • Directly actuated • Connections: push-in connector at both ends, thread/push-in connector • Push-in connector, can be rotated 360° 	<ul style="list-style-type: none"> • Piston regulator with through pressure supply • Without pressure gauge • Connections: thread/push-in connector on top or at side • Push-in connector, can be rotated 360°
→ Page/online	lrma	lrl



One-way flow control valves

				
Type	One-way flow control valve VFOF	One-way flow control valve VFOC	One-way flow control valve GRLA, GRLZ, CRGRLA, GRGA, GRGZ, GRLSA	One-way flow control valve GRXA-HG
Valve function	Exhaust air one-way flow control function	Supply air one-way flow control function	Exhaust air one-way flow control function, one-way flow control function, supply air one-way flow control function	Exhaust air one-way flow control function
Pneumatic connection 1	QS-6, QS-8	QS-4, QS-6	G1/8, G1/4, G1/2, G3/8, G3/4, M3, M5, PK-3, PK-3 with union nut, PK-4, PK-4 with union nut, PK-6 with union nut, QS-3, QS-4, QS-6, QS-8, QS-10, QS-12	QS-4, QS-6, QS-8
Standard nominal flow rate in flow control direction	250 ... 650 l/min	0 ... 270 l/min	0 ... 4,320 l/min	130 ... 280 l/min
Adjusting element	Internal hex	Slotted head screw	Knurled screw, slotted head screw	Slotted head screw
Description	<ul style="list-style-type: none"> • Minimal height • High flow rate • Can be rotated horizontally through 360° in assembled state • Functional combination with one-way flow control valve and piloted non-return valve 	<ul style="list-style-type: none"> • Shut-off valve, flow control at one end • Metal design • Precision adjustment for low and medium speeds • Push-in connector/push-in sleeve 	<ul style="list-style-type: none"> • Flow control valve, flow control at one end • Standard, mini, in-line variants with different flow rates • Functional combination with one-way flow control valve and piloted non-return valve • Polymer, metal or stainless steel design • Connections: thread at both ends, push-in connector at both ends, thread/push-in connector 	<ul style="list-style-type: none"> • Functional combination with one-way flow control valve and piloted non-return valve • Holding function and speed setting in one housing • Additional supply port for holding crossover interlinking
→ Page/online	609	vfoc	609	grxa-hg



One-way flow control valves

				
Type	One-way flow control valve GR, GRA	One-way flow control valve GG, GGO, GRR	Precision one-way flow control valve GRP	One-way flow control valve, M5 Compact System GRF
Valve function	One-way flow control function	One-way flow control function	One-way flow control function	One-way flow control function
Pneumatic connection 1	G1/2, G1/4, G1/8, G3/4, G3/8, M3, M5, QS-3, QS-4, QS-6, QS-8	G1/2, G1/4	G1/8, PK-3, PK-4	PK-3
Standard nominal flow rate in flow control direction	25 ... 3,300 l/min	870 ... 1,300 l/min	3.8 ... 75.8 l/min	45 l/min
Adjusting element	Knurled screw	Roller lever	Rotary knob with scale	Knurled screw
Description	<ul style="list-style-type: none"> Flow control valve In-line installation 	<ul style="list-style-type: none"> Flow control valve With roller lever 	<ul style="list-style-type: none"> Flow control valve Mounting on sub-base or for front panel mounting 	<ul style="list-style-type: none"> Complete system offering control components with all the functions required for pneumatic sequence controls For control cabinet installation Fast replacement of components
→ Page/online	gr	gs	grp	m5 compact



Flow control valves

			
Type	Flow control valve GRLO, GRGO	Flow control valve, barbed Y-connector with restrictor GRO, Y	Precision flow control valve GRPO
Valve function	Flow control function	Flow control function	Flow control function
Pneumatic connection 1	M3, M5	G1/4, G1/8, M5, QS-3, QS-4, QS-6	G1/8, PK-3, PK-4
Standard flow rate in flow control direction 6 → 0 bar	33 ... 169 l/min	25 ... 350 l/min	5.2 ... 129 l/min
Adjusting element	Slotted head screw	Knurled screw	Rotary knob with scale
Description	<ul style="list-style-type: none"> Flow control valve, flow control at both ends Standard or mini flow control valve Metal design Precision adjustment for low and medium speeds Connections: thread at both ends, thread/push-in connector Connections: elbow outlet or parallel outlet 	<ul style="list-style-type: none"> Flow control valve, flow control at both ends In-line flow control valve Polymer design Connections: push-in connector at both ends Connections: in-line, Y-shape 	<ul style="list-style-type: none"> Metal design Connections: threaded connection at both ends, push-in connector at both ends
→ Page/online	grlo	gro	grpo



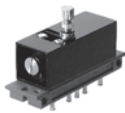

Flow control valves

		
Type	Exhaust air flow control valve, flow control/silencer GRE, GRU	Flow control/silencer VFFK
Valve function	Flow control/silencer function	Flow control/silencer function
Pneumatic connection 1	G1/8, G1/4, G1/2, G3/8, G3/4	M5, M7, R1/8, R1/4
Standard flow rate in flow control direction 6 → 0 bar	0 ... 8,000 l/min	0 ... 420 l/min
Adjusting element	Slotted head screw	Knurled screw
Description	<ul style="list-style-type: none"> Exhaust air flow control valve GRE: sintered metal Flow control/silencer GRU: polymer 	<ul style="list-style-type: none"> With polymer silencer
→ Page/online	gre	615



Time delay valves

		
Type	Time delay valve VZO, VZ, VLK	Time delay valve VZA, VZOA, VZB, VZOB
Pneumatic connection	PK-3	G1/4
Standard nominal flow rate	60 ... 90 l/min	600 l/min
Adjustable delay time	0.25 ... 5 s	0 ... 30 s
Operating pressure	2.5 ... 8 bar	0 ... 10 bar
Type of mounting	Optionally: front panel mounting, on mounting frame	Optionally: 2 through-holes in housing, front panel mounting
Description	<ul style="list-style-type: none"> Complete system offering control components with all the functions required for pneumatic sequence controls For control cabinet installation Fast replacement of components 	<ul style="list-style-type: none"> Time delay infinitely adjustable
→ Page/online	m5 compact	vza





Proportional valves

				
Type	Proportional pressure regulator VPPM	Proportional directional control valve VPWP	Proportional pressure regulator MPPE	Proportional pressure regulator MPPES
Valve function	3-way proportional pressure regulator	5/3-way proportional regulator, closed	3-way proportional pressure regulator, closed	3-way proportional pressure regulator, closed
Pneumatic connection 1	Sub-base, G1/8, G1/4, G1/2, NPT1/8-27, NPT1/4-18, NPT1/2-14	G1/4, G1/8, G3/8	G1/8, G1/4, G1/2	G1/8, G1/4, G1/2
Pressure regulation range	0.02 ... 10 bar	0 ... 10 bar	0 ... 10 bar	0 ... 10 bar
Standard nominal flow rate	380 ... 7,000 l/min	350 ... 2,000 l/min	350 ... 8,800 l/min	230 ... 8,500 l/min
Description	<ul style="list-style-type: none"> In-line valve Sub-base valve, flanged valve Piloted diaphragm regulator Integration in valve terminal MPA via fieldbus Multi-sensor control High repetition accuracy User interface with LED displays, LCD display, adjustment/selection buttons Setpoint value input as analogue voltage or current signal Integrated pressure sensor Electrical connection via plug, round design, 8-pin, M12 or terminal linking 	<ul style="list-style-type: none"> Regulated piston spool valve Digital actuation Integrated pressure sensors for monitoring function and force control With auto identification Diagnostic function Integrated digital output, e.g. for a clamping/brake unit Suitable for servopneumatic applications with CPX-CMAX and CPX-CPMX 	<ul style="list-style-type: none"> Pilot actuated piston regulator Setpoint value input as analogue voltage or current signal Choice of pressure regulation ranges Electrical connection via plug, round design to DIN 45326, M16 x 0.75, 8-pin Available with setpoint module See product documentation on our website for standard nominal flow rate 	<ul style="list-style-type: none"> Directly actuated (G1/8), piloted piston regulator (G1/4, G1/2) Setpoint value input as analogue voltage or current signal Choice of pressure regulation ranges, individual pressure regulation ranges on request Electrical connection via plug, round design to DIN 45326, M16 x 0.75, 8-pin Available with setpoint module See product documentation on our website for standard nominal flow rate
→ Page/online	vppm	vpwp	mppe	mppes





Proportional valves

		
Type	Proportional pressure regulator VPPE	Proportional directional control valve MPYE
Valve function	3-way proportional pressure regulator, 3-way proportional pressure regulator, closed	5/3-way, closed
Pneumatic connection 1	G1/8	G1/8, G1/4, G3/8, M5
Pressure regulation range	0.02 ... 10 bar	0 ... 10 bar
Standard nominal flow rate	310 ... 1,250 l/min	100 ... 2,000 l/min
Description	<ul style="list-style-type: none"> • Piloted diaphragm regulator • Setpoint input as analogue voltage signal (0 ... 10 V) • Electrical connection via plug M12x1, 4-pin • Available with setpoint module 	<ul style="list-style-type: none"> • Regulated piston spool valve • Analogue actuation • Setpoint input as analogue voltage signal (0 ... 10 V) • Suitable for servopneumatic applications with SPC200 and SPC11
→ Page/online	vppe	mpye





Process/media valves

				
Type	Reverse jet pulse valve VZWE-E, VZWE-F	Proportional media valve VZQA	Angle seat valve VZXF	Solenoid valve VZWD
Design	Angled version, straight version with flange, diaphragm valve	Proportional media valve, pneumatically actuated	Poppet valve with spring return	Directly actuated poppet valve
Valve function	2/2-way, single solenoid, closed	2/2-way, monostable, open	2/2-way, monostable, closed	2/2-way, single solenoid, closed
Standard nominal flow rate		12,800 l/min	3,000 ... 50,700 l/min	60 ... 170 l/min
Flow rate Kv	15 ... 210 m³/h		2.8 ... 47.5 m³/h	0.06 ... 0.4 m³/h
Process valve connection	G3/4, G1, G1 1/2, G2, G2 1/2, flange diameter 60 mm, 75 mm, 89 mm	G1/2	G1/2, G3/4, G1, G1 1/4, G1 1/2, G2, NPT1/2, NPT3/4, NPT1, NPT1 1/4, NPT1 1/2, NPT2	G1/8, G1/4
Actuation type	Electric	Pneumatic	Pneumatic	Electric
Description	<ul style="list-style-type: none"> • For mechanically cleaning filters and dust filter systems • High flow rates • Fast opening and closing times • Sturdy pilot system 	<ul style="list-style-type: none"> • The valve can be used to shut off media and mixtures of substances • Easy-to-clean design 	<ul style="list-style-type: none"> • Insensitive to steam or slightly contaminated media • No pressure differential required between the input and output • Low flow resistance • No dead space • Long service life • Low-maintenance 	<ul style="list-style-type: none"> • For applications with high pressure ranges and low flow rates • Use in vacuum technology • For venting gas and tank systems • As safety shut-off in burner controllers
→ Page/online	vzwe	vzqa	vzxf	vzwd



Process/media valves

Type	 Solenoid valve VZWF	 Solenoid valve VZWP	 Ball valve VZBC	 Ball valve actuator unit VZBC
Design	Diaphragm valve, force pilot operated	Piloted piston poppet valve, servo controlled	2-way ball valve	2-way ball valve, semi-rotary actuator
Valve function	2/2-way, single solenoid, closed	2/2-way, single solenoid, closed	2/2-way	2/2-way
Standard nominal flow rate	1,920 ... 29,900 l/min	1,600 ... 12,250 l/min		
Flow rate Kv	1.8 ... 28 m³/h	1.5 ... 11.5 m³/h	19.4 ... 1,414 m³/h	19.4 ... 1,414 m³/h
Process valve connection	G1/4, G3/8, G1/2, G3/4, G1, G1 1/4, G1 1/2, G2	G1/4, G3/8, G1/2, G3/4, G1	Ring housing with threaded flange	Ring housing with threaded flange
Actuation type	Electric	Electric	Mechanical	Pneumatic
Description	<ul style="list-style-type: none"> • Suitable for closed applications such as cooling or filling systems • Liquid gas • Bottling systems 	<ul style="list-style-type: none"> • For all applications with a differential pressure of 0.5 bar • For applications with an open medium circuit 	<ul style="list-style-type: none"> • Stainless steel, corrosion-resistant • Compact design 	<ul style="list-style-type: none"> • Stainless steel, corrosion-resistant • Compact design
→ Page/online	vzwf	vzwp	vzbc	vzbc



Process/media valves

Type	 Ball valve VAPB	 Ball valve VZBA	 Ball valve actuator unit VZBA	 Ball valve actuator unit VZPR
Design	2-way ball valve	2-way ball valve, 3-way ball valve, L-shaped hole, T-shaped hole	2-way ball valve, 3-way ball valve, L-shaped hole, semi-rotary actuator, T-shaped hole	2-way ball valve, semi-rotary actuator
Valve function	2/2-way	2/2-way, 3/2-way	2/2-way, 3/2-way	2/2-way
Standard nominal flow rate	5.9 ... 535 m³/h	7 ... 1,414 m³/h		
Flow rate Kv			7 ... 1,414 m³/h	5.9 ... 535 m³/h
Process valve connection	Rp1/4, Rp3/8, Rp1, Rp1 1/4, Rp1 1/2, Rp1/2, Rp3/4, Rp2, Rp2 1/2, Rp3, Rp4	Rp1/4, Rp3/8, Rp1/2, Rp3/4, Rp1, Rp1 1/4, Rp1 1/2, Rp2, Rp2 1/2, Rp3, Rp4, weld-on ends/weld-on ends	Rp1, Rp1 1/2, Rp1 1/4, Rp1/2, Rp1/4, Rp2, Rp2 1/2, Rp3, Rp3/4, Rp3/8, Rp4, weld-on ends/weld-on ends	Rp1/4, Rp3/8, Rp1/2, Rp3/4, Rp1, Rp1 1/4, Rp1 1/2, Rp2, Rp2 1/2
Actuation type	Mechanical	Mechanical	Pneumatic	Pneumatic
Description	<ul style="list-style-type: none"> • 2-way shut-off valve • Brass design • Actuation via accessories • Connecting thread to DIN 2999 • Mounting flange to ISO 5211 • Centring attachment for easy automation 	<ul style="list-style-type: none"> • 2-way or 3-way shut-off valve • Stainless steel design • Actuation via accessories • Connecting thread to DIN 2999 or DIN ISO 228-1 • Mounting flange to ISO 5211 • Centring attachment for easy automation 	<ul style="list-style-type: none"> • Combination of a pneumatic quarter turn actuator and a ball valve • Stainless steel design • Port pattern to NAMUR VDI/VDE 3845 • Flow is fully opened or closed in both directions • Limit switch attachments for end-position sensing can be flange-mounted directly 	<ul style="list-style-type: none"> • Pneumatic double-acting quarter turn actuator and 2-way ball valve • Flow is fully opened or closed in both directions • Brass or stainless steel design • Port pattern to Namur VDI/VDE3845
→ Page/online	vapb	vzba	vzba	vzpr



Process/media valves

			
Type	Solenoid valve VZWM	Solenoid valve MN1H-2	Pneumatic valve VLX
Design	Poppet valve with diaphragm seal	Diaphragm valve	Diaphragm valve
Valve function	2/2-way, single solenoid, closed	2/2-way, single solenoid, closed	2/2-way, monostable, closed
Standard nominal flow rate	1,400 ... 31,000 l/min	2,000 ... 30,500 l/min	2,400 ... 14,000 l/min
Flow rate Kv	1.6 ... 39 m³/h		
Process valve connection	G1/4, G3/8, G1/2, G3/4, G1, G1 1/4, G1 1/2, G2	G1/4, G3/8, G1/2, G3/4, G1, G1 1/2	G1/4, G3/8, G1/2, G3/4, G2
Actuating type	Electric	Electric	Pneumatic
Description	<ul style="list-style-type: none"> • Diaphragm valve • Indirectly actuated • Brass or stainless steel casting design • Wide range of coils • Electrical connection via solenoid armature tube system 8 or 13 • Voltage 24 V DC, 110/230 V AC 	<ul style="list-style-type: none"> • Poppet valve • Brass design • Adjustable closing cushioning • In-line mounting or via through-holes • Operating voltage 24 V DC, 110/230 V AC • Electrical connection via plug, square design to EN 175301-803, type A 	<ul style="list-style-type: none"> • Poppet valve • Indirectly actuated • Brass design • In-line mounting or via through-holes
→ Page/online	vzwm	mn1h-2	vlx

Pneumatic control systems

			
Type	Quickstepper FSS	Two-hand control block ZSB	Adding counter, M5 Compact System PZA, PZV
Design	Sequencer with 12 switching steps (additive)	Two-hand operation in accordance with EN ISO 12100	Mechanical sequence counter with pneumatic drive
Pneumatic connection	Barbed connector 3 mm, barbed connector 4 mm	G1/8	M5
Operating pressure	2 ... 6 bar	4 ... 8 bar	2 ... 8 bar
Type of mounting	On 2n mounting frame, front panel mounting	Mounting thread, optionally: with through-hole, with female thread	Front panel mounting, with through-hole
Description	<ul style="list-style-type: none"> • Pneumatic/mechanical sequencer with 12 steps and start logic circuits • Ready-to-install sequence controller • Acknowledgement-controlled motion sequences • Fast replacement, tubing can be left in place 	<ul style="list-style-type: none"> • Used wherever manual actuation poses a risk of accident to operating personnel • Safety component according to EU Machinery Directive 	<ul style="list-style-type: none"> • Complete system offering control components with all the functions required for pneumatic sequence controls • For control cabinet installation • Fast replacement of components • Available with protective cap
→ Page/online	fss	zsb	pza

Pneumatic control systems

		
Type	Timer, M5 Compact System PZVT, PZVT-S, PZVT-FR, PZVTAUT	Adding counter CCES
Design	Mechanical sequence counter with pneumatic drive	Electric adding counter with battery
Pneumatic connection	Female thread M5	
Operating pressure	2 ... 6 bar	
Type of mounting	Front panel mounting	Front panel mounting
Description	<ul style="list-style-type: none"> • Complete system offering control components with all the functions required for pneumatic sequence controls • For control cabinet installation • Fast replacement of components • Mechanical sequence counter with pneumatic drive • Adjustable delay time • Available with protective cap 	<ul style="list-style-type: none"> • 8-digit LCD display • Independent power supply • Connection via terminal strip • Reset button
→ Page/online	pzvt	cces

Customised components – for your specific requirements

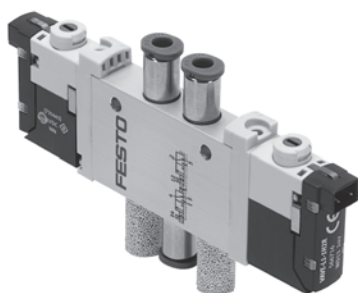

Valves with customised designs

Can't find the valve you need in our catalogue? We can offer you customised components that are tailored to your specific requirements – from minor product modifications to complete new product developments.

Common product modifications:

- Coatings for special ambient conditions
- Customised cables: length, pin allocation, pre-assembled with plug
- Modified actuating elements
- Modified connecting thread
- Modified valve sub-bases

Many additional variants are possible. Ask your Festo sales engineer, who will be happy to help. Further information on customised components can be found on your local website at www.festo.com.



Solenoid/pneumatic valves, to ISO 15407-1

FESTO

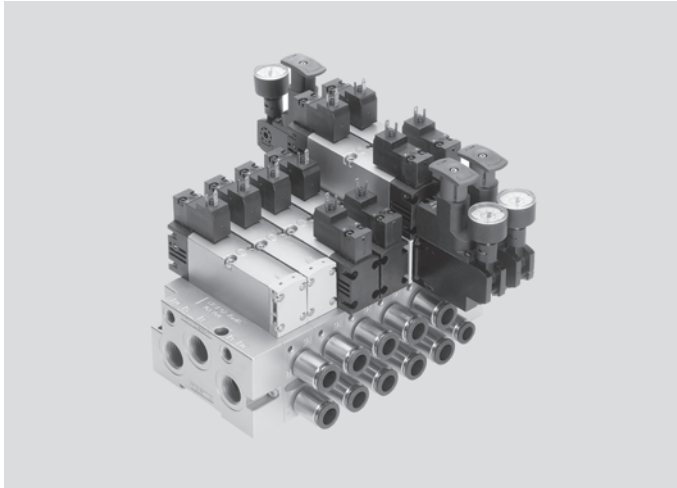

- Standard valve width 18/26 mm, flow rates up to 1,100 l/min
- Manifold assembly with mixed sizes possible
- Electrical connection via round or square plug socket
- Complete and standardised valve range
- Wide range of vertical stacking modules: pressure regulator plate, flow control plate, vertical pressure shut-off plate, etc.
- ★ Quick ordering of basic designs → 538

→ www.festo.com/catalogue/vsva

Product range overview

Type	Actuation type	Valve function	qnN [l/min]		Pilot air supply	→ Page/ online
			Width 18 mm	Width 26 mm		
VSVA-B-T22	Solenoid coil	2x 2/2-way valve, normally closed	500	1,000	Internal/external	vsva
VSVA-B-T32	Pilot interface to ISO 15218 Plug type C 12, 24 V DC	2x 3/2-way valve, normally closed	400	900	Internal/external	535
		2x 3/2-way valve, normally open				
		2x 3/2-way valve, normally closed/open				
VSVA-B-M52	24, 110, 230 V AC	5/2-way valve, single pilot	550	1,100	Internal/external	535
VSVA-B-B52	Plug M12 24 V DC	5/2-way valve, double solenoid	550	1,100	Internal/external	536
VSVA-B-D52		5/2-way valve, double solenoid	550	1,100	Internal/external	vsva
VSVA-B-P53C	Round central plug M8/M12 24 V DC	5/3-way valve, normally closed	450	1,000	Internal/external	536
VSVA-B-P53U		5/3-way valve, normally open	450	1,000	Internal/external	vsva
VSVA-B-P53E		5/3-way valve, normally exhausted	450	1,000	Internal/external	vsva
VSPA-B-T32	Pneumatic	2x 3/2-way valve, normally closed	400	900	-	542
		2x 3/2-way valve, normally open				
		2x 3/2-way valve, normally closed/open				
VSPA-B-M52		5/2-way valve, monostable	550	1,100		542
VSPA-B-B52		5/2-way valve, bistable	550	1,100		543
VSPA-B-D52		5/2-way valve, bistable	550	1,100		vsva
VSPA-B-P53C		5/3-way valve, normally closed	450	1,000		543
VSPA-B-P53U		5/3-way valve, normally open	450	1,000		vsva
VSPA-B-P53E		5/3-way valve, normally exhausted	450	1,000		vsva

Solenoid valves VSVA, to ISO 15407-1

Technical data

Download CAD data → www.festo.com

Technical data		18 mm		26 mm	
Width					
Valve function		2x 3/2-way single solenoid	5/2-way single solenoid	5/2-way double solenoid	5/3-way closed
Sub-base	1, 2, 3, 4, 5	G1/8		G1/4	
Pilot air	12, 14	M5		M5	
Design		Piston spool valve			
Type of mounting		Via through-hole on sub-base			
Electrical data – Valve with central plug M8x1, M12x1					
Operating voltage	[V DC]	24			
Power consumption	DC [W]	High-current phase: 2.4; low-current phase: 1			
Protective circuit and LED		Integrated in the valve			
Electrical connection		Central plug, round design, M8x1 or M12x1			
Protection class to EN 60529		With plug socket to IP65			
Electrical data – Valve with plug type C					
Operating voltage	[V DC]	24			
	[V AC]	24, 110, 230			
Power consumption	DC [W]	1.8			
	AC [VA]	2.1 at 110/230 V 2.3 at 24 V			
Electrical connection		Plug, square design to EN 175301-803, type C			
Protection class to EN 60529		With plug socket to IP65			

8

Operating conditions		
Operating medium		Compressed air to ISO 8573-1:2010 [7:4:4]
Note on operating/pilot medium		Lubricated operation possible (in which case lubricated operation will always be required)
Ambient temperature	[°C]	-5 ... +50
Temperature of medium	[°C]	-5 ... +50

Materials		
Housing		Die cast aluminium
Seals		NBR
Screws		Galvanised steel

Technical data – 2x 3/2-way valve

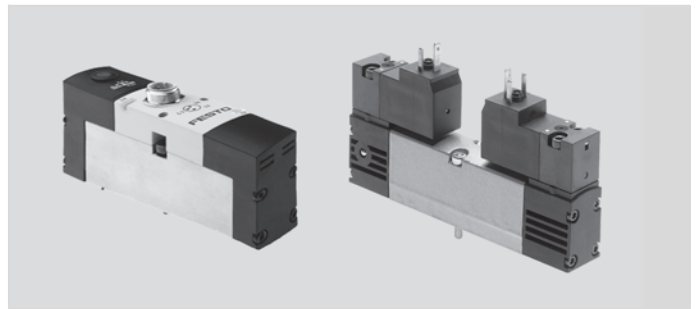
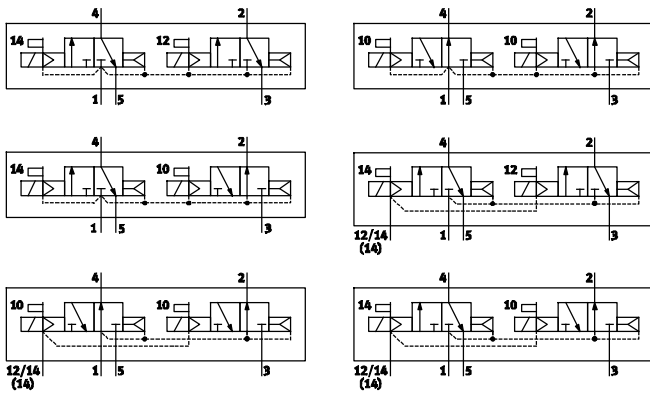

Technical data		Plug M8x1, M12x1		Plug type C	
		Download CAD data → www.festo.com			
Electrical connection		Plug M8x1, M12x1		Plug type C	
Width		18 mm		26 mm	
Operating pressure	Internal pilot air supply	[bar] 3 ... 8		2 ... 10	
	External pilot air supply	[bar] 3 ... 10		2 ... 10	
Pilot pressure		[bar] 3 ... 8		3 ... 10	
Standard nominal flow rate qnN		[l/min] 400		900	
Switching time on/off	Non-reversible types	[ms] 10/22		20/33	
	Reversible types	[ms] –		13/21	
Length/width/height		[mm] 108/18/57		113/27/67	
				108/18/63	
				114/27/72	

Technical data – 5/2-way valve, single solenoid

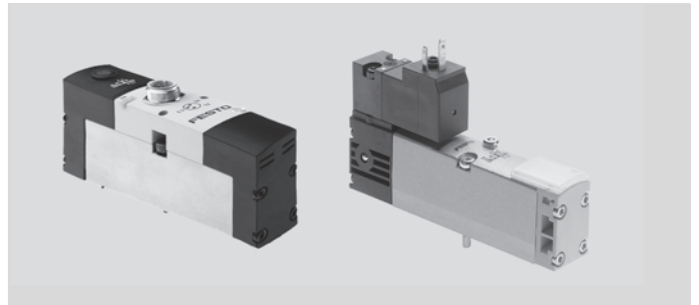
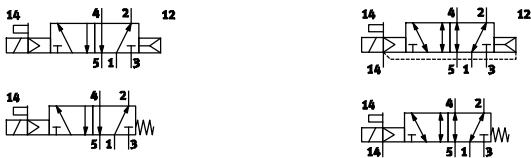

Technical data		Plug M8x1, M12x1		Plug type C	
		Download CAD data → www.festo.com			
Electrical connection		Plug M8x1, M12x1		Plug type C	
Width		18 mm		26 mm	
Reset method		Mechanical	Pneumatic	Mechanical	Pneumatic
Operating pressure	Internal pilot air supply	[bar] 3 ... 8		3 ... 10	
	External pilot air supply	[bar] -0.9 ... +10		-0.9 ... +16	
Pilot pressure		[bar] 3 ... 8		3 ... 10	
Standard nominal flow rate qnN		[l/min] 550		1,100	
Switching time on/off	[ms]	12/34	20/25	20/52	25/40
		17/35	21/19	26/56	35/43
Length/width/height		[mm] 108/18/57		113/27/67	
				96/18/63	
				114/27/72	

Solenoid valves VSVA, to ISO 15407-1

Technical data – 5/2-way valve, double solenoid

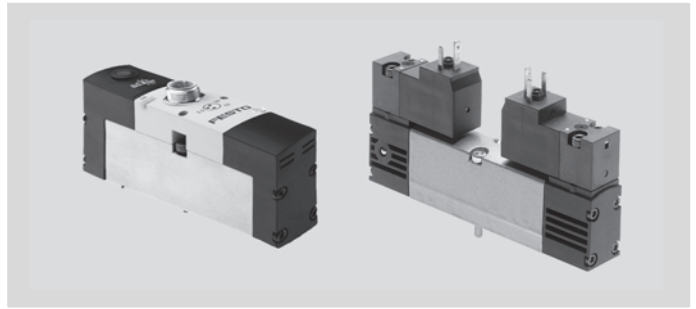

Technical data		Download CAD data → www.festo.com			
Electrical connection		Plug M8x1, M12x1		Plug type C	
Width		18 mm	26 mm	18 mm	26 mm
Operating pressure	Internal pilot air supply [bar]	3 ... 8	3 ... 8	2 ... 10	2 ... 10
	External pilot air supply [bar]	-0.9 ... +10	-0.9 ... +16	-0.9 ... +10	-0.9 ... +16
Pilot pressure [bar]		3 ... 8	3 ... 8	3 ... 10	3 ... 10
Standard nominal flow rate q _N	[l/min]	550	1,100	550	1,100
Changeover time [ms]		10	15	15	18
Length/width/height [mm]		108/18/57	113/27/67	108/18/63	127/27/72

Technical data – 5/3-way valve, normally closed

8

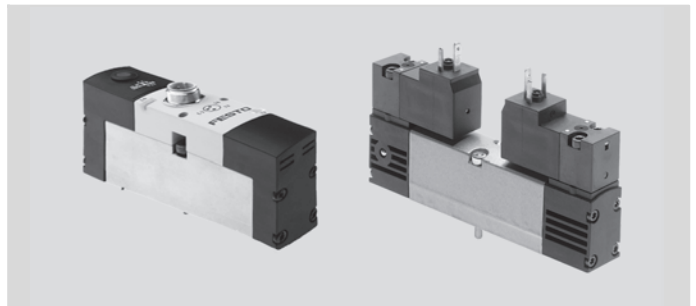
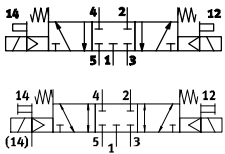

Technical data		Download CAD data → www.festo.com			
Electrical connection		Plug M8x1, M12x1		Plug type C	
Width		18 mm	26 mm	18 mm	26 mm
Operating pressure	Internal pilot air supply [bar]	3 ... 8	3 ... 8	3 ... 10	3 ... 10
	External pilot air supply [bar]	-0.9 ... +10	-0.9 ... +16	-0.9 ... +10	-0.9 ... +16
Pilot pressure [bar]		3 ... 8	3 ... 8	3 ... 10	3 ... 10
Standard nominal flow rate q _N	[l/min]	450	1,000	450	1,000
Switching time on/off [ms]		15/36	20/52	18/30	23/58
Length/width/height [mm]		108/18/57	113/27/67	108/18/63	127/27/72

Solenoid valves VSVA, to ISO 15407-1

FESTO

Ordering – Product options

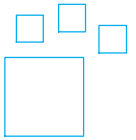

Configurable product

This product and all its options can be ordered using the configurator.

The configurator can be found under Products on the DVD or



[→ www.festo.com/catalogue/...](http://www.festo.com/catalogue/...)

Enter the type code in the search field.

★ Quick ordering

			Part No.	Type
5/2-way valve, single solenoid, ISO size 18 mm				
Without pilot valve	Mechanical spring	Internal pilot air supply	546742	VSVA-B-M52-M-A2-P1
With pilot control with square plug, type C	Pneumatic spring	Internal pilot air supply	546701	VSVA-B-M52-AH-A2-1C1
		External pilot air supply	547079	VSVA-B-M52-AZH-A2-1C1
	Mechanical spring	Internal pilot air supply	546703	VSVA-B-M52-MH-A2-1C1
		External pilot air supply	547081	VSVA-B-M52-MZH-A2-1C1
With pilot control with round plug M8x1	Pneumatic spring	Internal pilot air supply	534774	VSVA-B-M52-AH-A2-1R2L
	Mechanical spring	Internal pilot air supply	534775	VSVA-B-M52-MH-A2-1R2L
With pilot control with round plug M12x1	Pneumatic spring	Internal pilot air supply	546767	VSVA-B-M52-AH-A2-1R5L
		External pilot air supply	546768	VSVA-B-M52-MH-A2-1R5L
	Mechanical spring	Internal pilot air supply	546778	VSVA-B-M52-MZH-A2-1R5L
5/2-way valve, double solenoid, ISO size 18 mm				
Without pilot valves			546736	VSVA-B-B52-A2-P1
With pilot control with square plug, type C			546697	VSVA-B-B52-H-A2-1C1
With pilot control with round plug M8x1			534776	VSVA-B-B52-H-A2-1R2L
With pilot control with round plug M12x1			546769	VSVA-B-B52-H-A2-1R5L
5/2-way valve, single solenoid, ISO size 26 mm				
With pilot control with square plug, type C	Pneumatic spring	Internal pilot air supply	546700	VSVA-B-M52-AH-A1-1C1
		External pilot air supply	547078	VSVA-B-M52-AZH-A1-1C1
	Mechanical spring	Internal pilot air supply	546702	VSVA-B-M52-MH-A1-1C1
		External pilot air supply	547080	VSVA-B-M52-MZH-A1-1C1
With pilot control with round plug M8x1	Pneumatic spring	Internal pilot air supply	534535	VSVA-B-M52-AH-A1-1R2L
		External pilot air supply	534526	VSVA-B-M52-MZH-A1-1R2L
	Mechanical spring	Internal pilot air supply	534536	VSVA-B-M52-MH-A1-1R2L
With pilot control with round plug M12x1	Pneumatic spring	Internal pilot air supply	534555	VSVA-B-M52-AH-A1-1R5L
		External pilot air supply	534545	VSVA-B-M52-AZH-A1-1R5L
	Mechanical spring	Internal pilot air supply	534556	VSVA-B-M52-MH-A1-1R5L
		External pilot air supply	534546	VSVA-B-M52-MZH-A1-1R5L
5/2-way valve, double solenoid, ISO size 26 mm				
With pilot control with square plug, type C	Internal pilot air supply		546696	VSVA-B-B52-H-A1-1C1
	External pilot air supply		547074	VSVA-B-B52-ZH-A1-1C1
With pilot control with round plug M8x1	Internal pilot air supply		534537	VSVA-B-B52-H-A1-1R2L
With pilot control with round plug M12x1	Internal pilot air supply		534557	VSVA-B-B52-H-A1-1R5L
	External pilot air supply		534547	VSVA-B-B52-ZH-A1-1R5L
5/3-way solenoid valve, ISO size 26 mm				
With pilot control with square plug, type C	Internal pilot air supply		546706	VSVA-B-P53E-H-A1-1C1
With pilot control with round plug M12x1	Internal pilot air supply		534560	VSVA-B-P53E-H-A1-1R5L
	External pilot air supply		534550	VSVA-B-P53E-ZH-A1-1R5L

Technical data – Regulator plate VABF-S3

-  - Temperature range
-5 ... +50 °C
-  - Operating pressure range
0.5 ... 6 bar
0.5 ... 10 bar

Materials
Housing: Die-cast aluminium
Control section: Polyamide

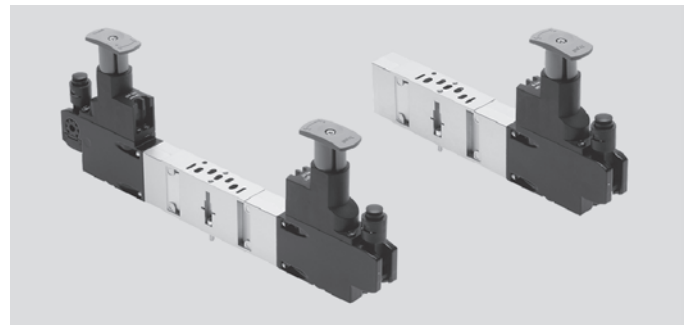

Order code

		VABF-S3	-			C2-C	-	
Type								
VABF-S3	Valve accessories, function plate to ISO 15407-1							
Width								
1	26 mm							
2	18 mm							
Function								
R1	Pressure regulator for port 1							
R2	Pressure regulator for port 2							
R3	Pressure regulator for port 4							
R4	Pressure regulator for port 2 and 4							
R5	Pressure regulator for port 2 and 4, reverse operation							
R6	Pressure regulator for port 2, reverse operation							
R7	Pressure regulator for port 4, reverse operation							
Options								
C2-C	Pressure gauge connection closed							
Pressure regulation range								
6	Up to 6 bar							
10	Up to 10 bar							

Solenoid valves VSVA, to ISO 15407-1

Accessories – Manifold assembly

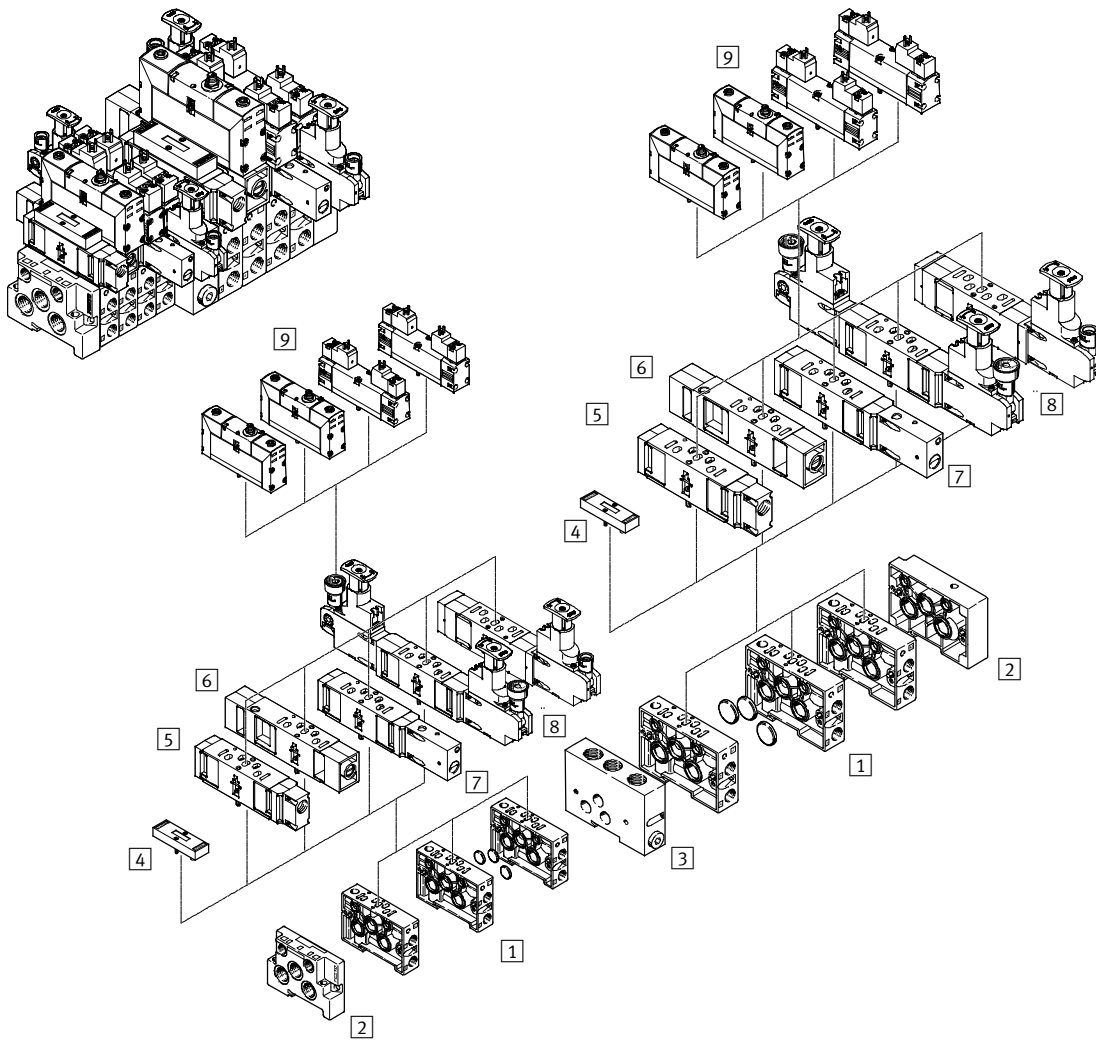

8

Variants and accessories		→ Page/online
1	Manifold sub-base NAW with lateral ports 2 and 4	547
2	End plate kit NEV for sealing the manifold sub-bases	547
3	Intermediate plate NZV for connecting width 18 mm with width 26 mm	547
4	Blanking plate NDV for vacant or spare positions	547
5	Vertical supply plate VABF...P1-A3 for intermediate air supply	547
6	Flow control plate VABF...F1-B1 for flow control in ducts 3 and 5	547
7	Vertical pressure shut-off plate VABF...L1-D1 with switch for manual shut-off of duct 1	547
8	Pressure regulator plate VABF...R...-C2	539
9	Solenoid valve VSVA	533
-	Individual sub-base	547

Accessories – Manifold assembly

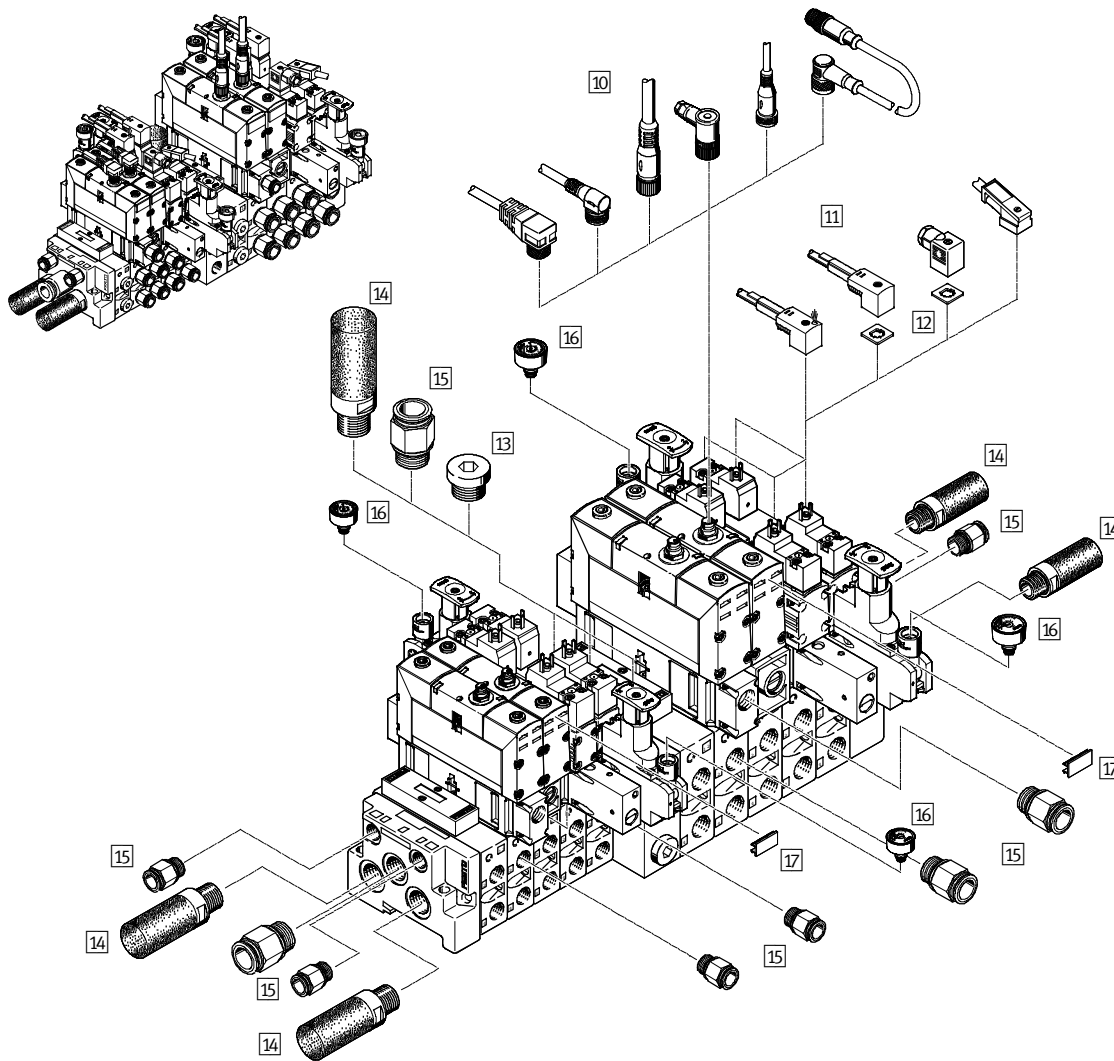

Accessories	→ Page/online
10 Round plug connector NEBU/SEA for connecting cable/plug socket M8/M12	548
11 Square plug, type C, KMEB/MSSD-EB for connecting cable/plug socket	548
12 Illuminating seal MEB-LD for displaying the signal status	548
13 Blanking plug B for sealing unused ports	548
14 Silencer U for fitting in exhaust ports	548
15 Push-in fitting QS for compressed air tubing with standard O.D.	548
16 Pressure gauge PAGN-26-10-P10 for connection to the pressure regulator plate	548
17 Inscription labels IBS-9x20 for identifying the valves VSVA with round plug	548
– Individual sub-base	547

Pneumatic valves VSPA, to ISO 15407-1

Technical data

Technical data		Download CAD data → www.festo.com							
Width		18 mm				26 mm			
Valve function		2x 3/2-way monostable	5/2-way monostable	5/2-way bistable	5/3-way closed	2x 3/2-way monostable	5/2-way monostable	5/2-way bistable	5/3-way closed
Sub-base	1, 2, 3, 4, 5	G1/8				G1/4			
Pilot air	12, 14	M5				M5			
Type of mounting		Via through-hole on sub-base							
Operating medium		Compressed air to ISO 8573-1:2010 [7:4:4]							
Note on operating/pilot medium		Lubricated operation possible (in which case lubricated operation will always be required)							
Ambient temperature	[°C]	-5 ... +60							
Temperature of medium	[°C]	-5 ... +60							

Materials	
Housing	Die-cast aluminium
Seals	NBR
Screws	Galvanised steel

Technical data – 2x 3/2-way valve

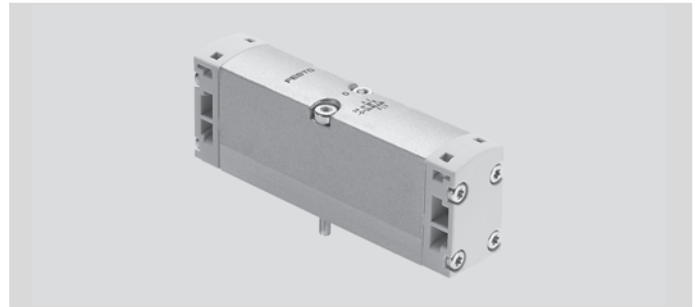
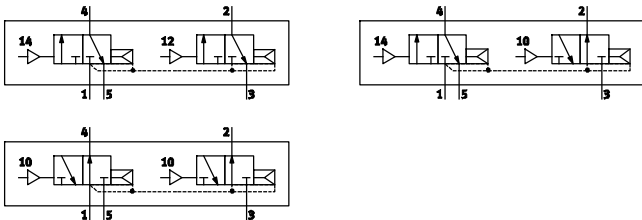

Technical data		Download CAD data → www.festo.com	
Width		18 mm	26 mm
Operating pressure	[bar]	2 ... 10	2 ... 10
Pilot pressure	[bar]	2 ... 10	2 ... 10
Standard nominal flow rate qnN	[l/min]	400	900
Switching time on/off	[ms]	10/22	15/28
Design		Piston spool valve	
Length/width/height	[mm]	83/18/29	100/26/38

Technical data – 5/2-way valve, monostable

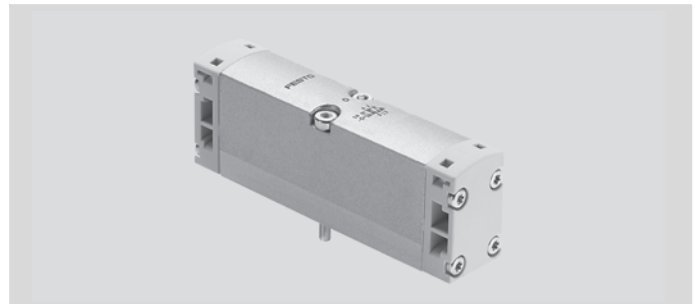
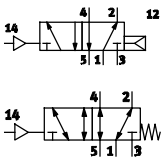

Technical data		Download CAD data → www.festo.com			
Width		18 mm		26 mm	
Reset method		Mechanical	Pneumatic	Mechanical	Pneumatic
Operating pressure	[bar]	-0.9 ... +10		-0.9 ... +10	
Pilot pressure	[bar]	3 ... 10		3 ... 8	
Standard nominal flow rate qnN	[l/min]	550		1,100	
Switching time on/off	[ms]	8/10	11/20	10/35	18/30
Design		Piston spool valve			
Length/width/height	[mm]	83/18/29		100/26/38	

Technical data – 5/2-way valve, bistable

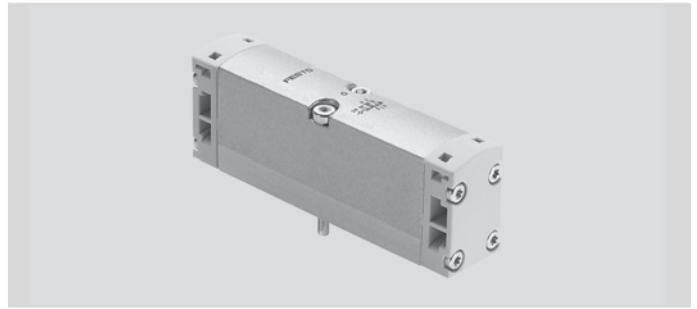
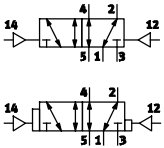

Technical data		Download CAD data → www.festo.com	
Width		18 mm	26 mm
Operating pressure	[bar]	−0.9 ... +10	−0.9 ... +10
Pilot pressure	[bar]	2 ... 10	2 ... 10
Standard nominal flow rate q _N	[l/min]	550	1,100
Changeover time	[ms]	6	10
Design		Piston spool valve	
Length/width/height	[mm]	83/18/29	100/26/38

Technical data – 5/3-way valve, normally closed

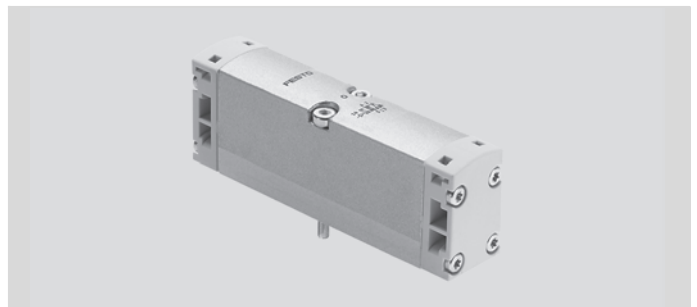
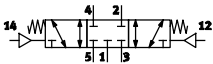

Technical data		Download CAD data → www.festo.com	
Width		18 mm	26 mm
Operating pressure	[bar]	−0.9 ... +10	−0.9 ... +10
Pilot pressure	[bar]	3 ... 10	3 ... 10
Standard nominal flow rate q _N	[l/min]	450	1,000
Switching time on/off	[ms]	9/18	13/32
Design		Piston spool valve	
Length/width/height	[mm]	83/18/29	100/26/38

Pneumatic valves VSPA, to ISO 15407-1

Order code – Pneumatic valve

VSPA		B			
Type					
VSPA	Standard valve to ISO 15407-1/-2				
Version					
B	Sub-base valve				
Valve function					
T32C	2x 3/2-way valve, monostable, normally closed				
T32U	2x 3/2-way valve, monostable, normally open				
T32H	2x 3/2-way valve, monostable, 1x normally closed, 1x open				
M52-A	5/2-way valve, monostable, pneumatic spring return				
M52-M	5/2-way valve, monostable, mechanical spring return				
B52	5/2-way valve, bistable				
D52	5/2-way valve, bistable with dominant signal at 14				
P53C	5/3-way valve, normally closed				
P53U	5/3-way valve, normally open				
P53E	5/3-way valve, normally exhausted				
Pneumatic connection					
A1	Port pattern to ISO size 26 mm (01)				
A2	Port pattern to ISO size 18 mm (02)				

8

Ordering – Product options



Configurable product

This product and all its options can be ordered using the configurator.

The configurator can be found under Products on the DVD or
[→ www.festo.com/catalogue/...](http://www.festo.com/catalogue/...)

Enter the type code in the search field.

★ Quick ordering

		Part No.	Type
ISO size 18 mm			
5/2-way pneumatic valve, monostable	Pneumatic spring	546726	VSPA-B-M52-A-A2
	Mechanical spring	546727	VSPA-B-M52-M-A2
5/2-way pneumatic valve, bistable	Dominant 1st signal	546724	VSPA-B-B52-A2
ISO size 26 mm			
5/2-way pneumatic valve, monostable	Pneumatic spring	546716	VSPA-B-M52-A-A1
	Mechanical spring	546717	VSPA-B-M52-M-A1
5/2-way pneumatic valve, bistable	Dominant 1st signal	546714	VSPA-B-B52-A1

Accessories – Manifold assembly

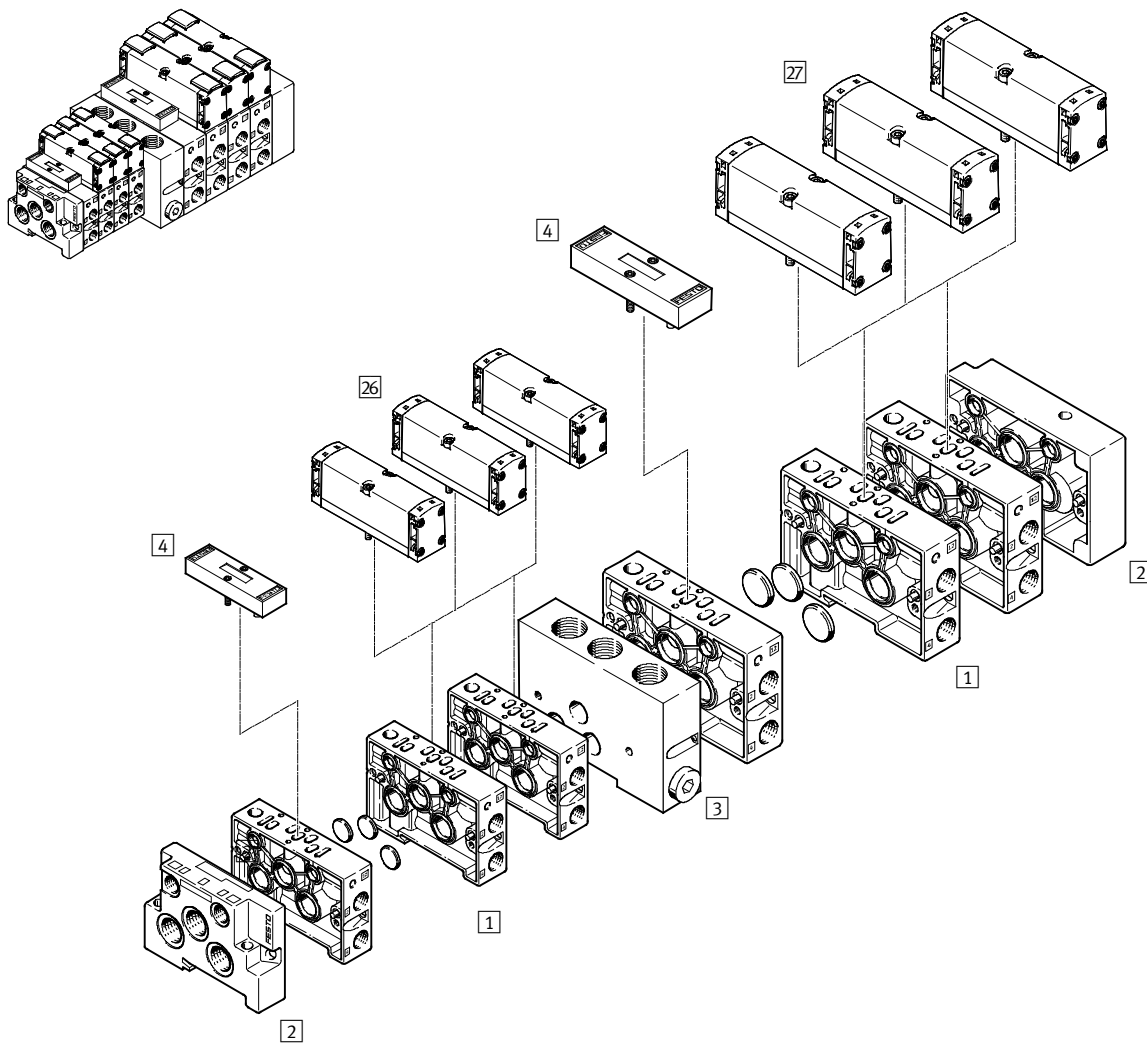

Variants and accessories		→ Page/online
1	Manifold sub-base with lateral ports 2 and 4	547
2	End plate kit NEV for sealing the manifold sub-bases	547
3	Intermediate plate NZV for connecting width 18 mm with width 26 mm	547
4	Blanking plate NDV for vacant or spare positions	547
26	Pneumatic valve VSPA...A2, width 18	537
27	Pneumatic valve VSPA...A1, width 26	537
-	Individual sub-base	547

Accessories – Manifold assembly

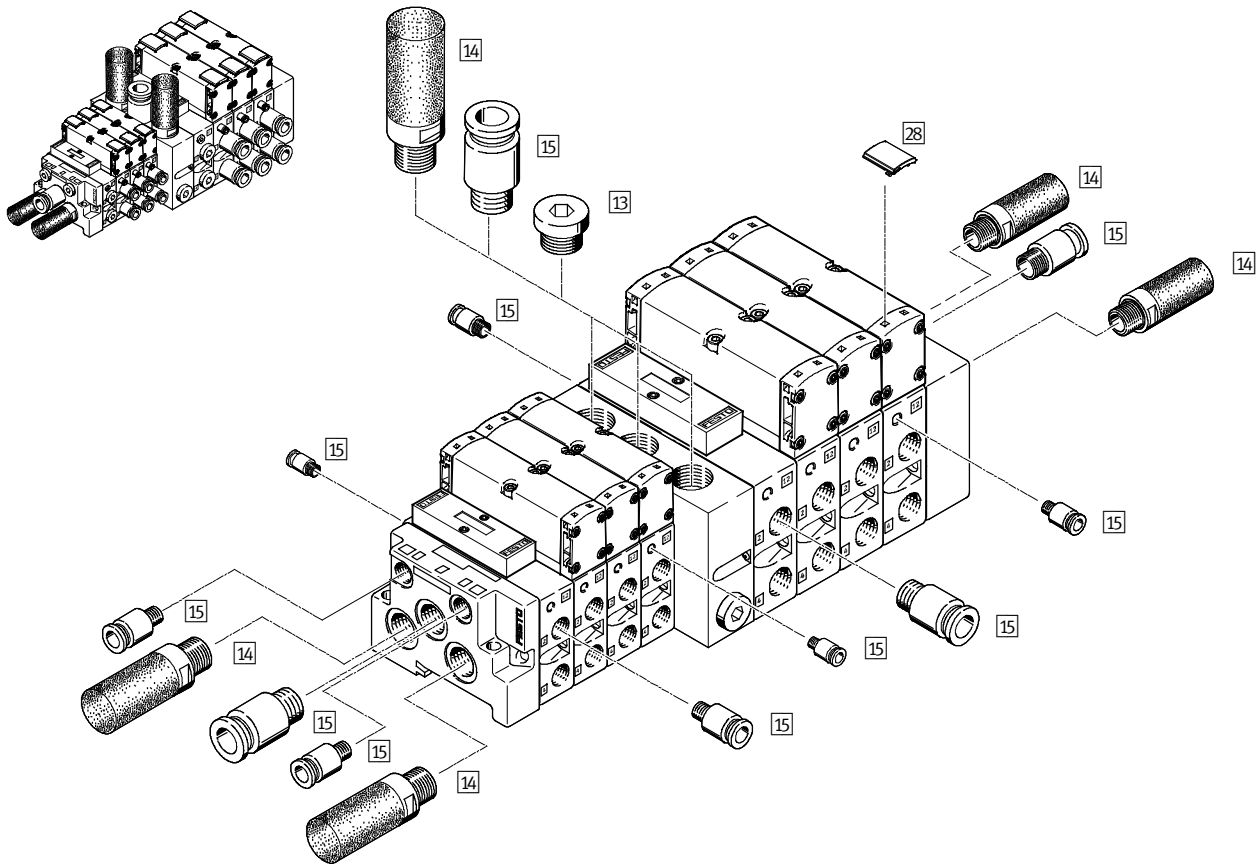

Accessories	→ Page/online
13 Blanking plug B for sealing unused ports	548
14 Silencer U for fitting in exhaust ports	548
15 Push-in fitting QS for compressed air tubing with standard O.D.	548
28 Inscription label holder ASCF for identifying the valves	548
– Individual sub-base	547



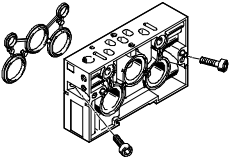
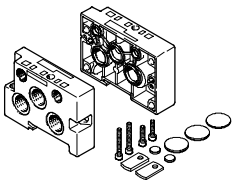
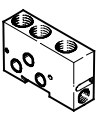
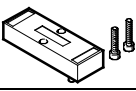
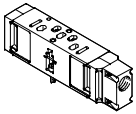
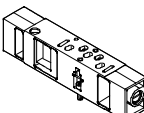
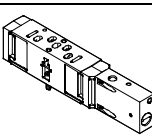
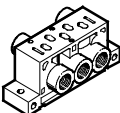



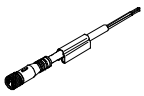
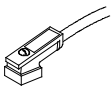

Accessories – Ordering data

	Description		Part No.	Type
1 Manifold sub-base with lateral ports 2 and 4				
	For solenoid valve	18 mm	★ 161110	NAW-1/8-02-VDMA
		26 mm	★ 161102	NAW-1/4-01-VDMA
	For pneumatic valve	18 mm	161111	NAW-1/8-02-VDMA-VL
		26 mm	161103	NAW-1/4-01-VDMA-VL
2 End plate kit				
	Width 18 mm	★	161112	NEV-02-VDMA
	Width 26 mm	★	161104	NEV-01-VDMA
3 Intermediate plate for connecting the sizes 02 and 01				
	Width 18/26 mm		161108	NZV-01/02-VDMA
4 Blanking plate for vacant position				
	Width 18 mm	★	161114	NDV-02-VDMA
	Width 26 mm	★	161107	NDV-01-VDMA
5 Vertical supply plate				
	Width 18 mm		544435	VABF-S3-2-P1A3-G18
	Width 26 mm		544434	VABF-S3-1-P1A3-G14
6 Flow control plate				
	Width 18 mm		543603	VABF-S3-2-F1B1-C
	Width 26 mm		543604	VABF-S3-1-F1B1-C
7 Vertical pressure shut-off plate				
	Width 18 mm		543601	VABF-S3-2-L1D1-C
	Width 26 mm		543602	VABF-S3-1-L1D1-C
Individual sub-base				
	Width 18 mm	★	161115	NAS-1/8-02-VDMA
	Width 26 mm	★	161109	NAS-1/4-01-VDMA

Solenoid/pneumatic valves, to ISO 15407-1

FESTO

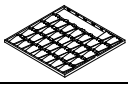
Accessories – Ordering data

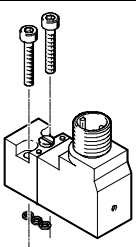
		Description		Part No.	Type	
10		Round plug connector			Technical data → 949	
	Connecting cable M8	Straight socket	2.5 m	541342	NEBU-M8G4-K-2.5-LE4	
			5 m	541343	NEBU-M8G4-K-5-LE4	
		Angled socket	2.5 m	541344	NEBU-M8W4-K-2.5-LE4	
			5 m	541345	NEBU-M8W4-K-5-LE4	
	Connecting cable M12	Straight socket	2.5 m	550326	NEBU-M12G5-K-2,5-LE4	
			5 m	541328	NEBU-M12G5-K-5-LE4	
		Angled socket	5 m	541329	NEBU-M12W5-K-5-LE4	
		Plug socket M12, angled socket, 4-pin, screw terminal		185498	SEA-M12-4WD-PG7	
11		Square plug type C			Technical data online: → kmeb	
	Connecting cable	24 V DC, with LED	2.5 m	174844	KMEB-2-24-2,5-LED	
			5 m	174845	KMEB-2-24-5-LED	
		Up to 230 V AC, without LED	2.5 m	174846	KMEB-2-230-2,5	
			5 m	174847	KMEB-2-230-5	
	Plug socket	Screw terminal connection			151687	MSSD-EB
Insulation displacement connection			192745	MSSD-EB-S-M14		
12		Illuminating seal for plug type C				
	12 ... 24 V DC			151717	MEB-LD-12-24DC	
	230 V AC			151718	MEB-LD-230AC	
13		Blanking plug			Technical data online: → b-1	
	For thread G1/8			3568	B-1/8	
	For thread G3/8			3570	B-3/8	
	For thread G1/2			3571	B-1/2	
14		Silencer			Technical data → 994	
	For thread G1/8		★	6841	U-1/8-B	
	For thread G3/8		★	6843	U-3/8-B	
	For thread G1/2		★	6844	U-1/2-B	
15		Push-in fitting			Technical data → 908	
	For thread G1/8		★	186098	QS-G1/8-8	
	For thread G3/8		★	186103	QS-G3/8-12	
	For thread G1/2		★	186104	QS-G1/2-12	
16		Pressure gauge			Technical data online: → pagn	
	With cartridge fitting connection for regulator, 0 ... 16 bar			543487	PAGN-26-16-P10	
17		Inscription label for valves				
	Scope of delivery 24 labels in frame			18182	IBS-9x20	
28		Inscription label holder				
	Clip-on for valve cap			540888	ASCF-T-S6	
Pilot valve to ISO 15218					Technical data online: → vscs	
	Plug, square design, type C		24 V DC	★	546256	VSCS-B-M32-MH-WA-1C1
	Plug M12		24 V DC		573215	VSCS-B-M32-MD-WA-1R3

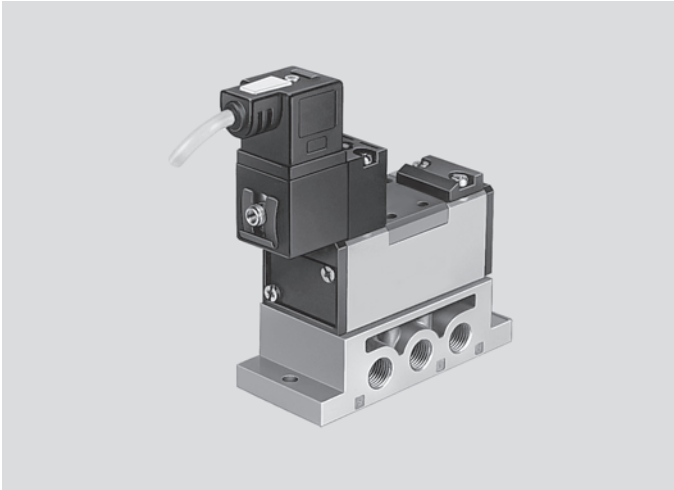

- Standard valve width 42/54/65/76 mm, flow rates up to 6,000 l/min
 - Manifold assembly with mixture of ISO sizes 1/2/3 possible
 - Electrical connection via square plug socket, round plug socket or versatile F coil
 - Wide range of vertical stacking modules: pressure regulator plate, flow control plate, vertical pressure shut-off plate, etc.
- ★ Quick ordering of basic designs → 559

→ www.festo.com/catalogue/5599-1

Product range overview

Type	Actuation type	Valve function	qnN [l/min]				Pilot air supply	→ Page/ online
			ISO size					
			1	2	3	4		
MN1H-5/2	N1 solenoid coil ¹⁾	5/2-way valve, single solenoid	1,200	2,300	4,500	–	Internal/external	551
JMN1H-5/2	12, 24 V DC	5/2-way valve, double solenoid			4,500			551
JMN1DH-5/2	24, 110, 230 V AC	5/2-way valve, double solenoid, dominant signal at 14			4,500			5599-1
MN1H-5/3G		5/3-way valve, normally closed			4,100			551
MN1H-5/3B		5/3-way valve, normally open			4,000			5599-1
MN1H-5/3E		5/3-way valve, normally exhausted			4,600			
MEBH-5/2	EB solenoid coil	5/2-way valve, single solenoid	1,200	2,300	4,500	–	Internal	553
JMEBH-5/2	24 V DC	5/2-way valve, double solenoid			4,500			553
JMEBDH-5/2		5/2-way valve, double solenoid, dominant signal at 14			4,500			5599-1
MEBH-5/3G		5/3-way valve, normally closed			4,100			554
MEBH-5/3B		5/3-way valve, normally open			4,000			5599-1
MEBH-5/3E		5/3-way valve, normally exhausted			4,600			
VSVA-B-T32C	Solenoid coil with central plug M12	2x 3/2-way valve, 2x normally closed	1,100	2,200	–	–	Internal/external	555
VSVA-B-T32U		2x 3/2-way valve, 2x normally open						
VSVA-B-T32H	24 V DC	2x 3/2-way valve, 1x normally open, 1x closed						
VSVA-B-M52		5/2-way valve, single solenoid	1,300	2,800				556
VSVA-B-B52		5/2-way valve, double solenoid						
VSVA-B-D52		5/2-way valve, double solenoid, dominant signal at 14						
VSVA-B-P53C		5/3-way valve, normally closed						557
VSVA-B-P53U		5/3-way valve, normally open						
VSVA-B-P53E		5/3-way valve, normally exhausted						
MFH-5/2	F solenoid coil	5/2-way valve, single solenoid	1,200	2,300	4,500	–	Internal/external	561
JMFH-5/2	12, 24, 42,	5/2-way valve, double solenoid			4,500			562
JMFDH-5/2	48 V DC	5/2-way valve, double solenoid, dominant signal at 14			4,500			5599-1
MFH-5/3G	24, 42, 48, 110,	5/3-way valve, normally closed			4,100			
MFH-5/3B	230 V AC	5/3-way valve, normally open			4,000			
MFH-5/3E		5/3-way valve, normally exhausted			4,600			562
MDH-5/2...-M12	D solenoid coil	5/2-way valve, single solenoid	1,200	2,300	4,500	–	Internal/external	5599-1
JMDH-5/2...-M12	24 V DC	5/2-way valve, double solenoid			4,000		Internal	
JMDDH-5/2...-M12		5/2-way valve, double solenoid, dominant signal at 14			4,000			
MDH-5/3G...-M12		5/3-way valve, normally closed			4,100			
MDH-5/3B...-M12		5/3-way valve, normally open			4,000			
MDH-5/3E...-M12		5/3-way valve, normally exhausted			4,600			

1) The solenoid coil must be ordered separately.

Solenoid valves, to ISO 5599-1

FESTO

Product range overview

Type	Actuation type	Valve function	qnN [l/min]				Pilot air supply	→ Page/online
			ISO size					
			1	2	3	4		
MDH-5/2-3/4	D solenoid coil 24 V DC 42, 110, 230 V AC	5/2-way valve, single solenoid	–	–	–	6,000	Internal	5599-1
JMDH-5/2-3/4		5/2-way valve, double solenoid						
MDH-5/3G-3/4		5/3-way valve, normally closed						
MDH-5/3E-3/4		5/3-way valve, normally exhausted						
VL-5/2	Pneumatic	5/2-way valve, monostable	1,200	2,300	4,500	6,000	None	5599-1
J-5/2		5/2-way valve, bistable						
JD-5/2		5/2-way valve, bistable with dominant signal at 14						
VL-5/3G		5/3-way valve, normally closed						
VL-5/3B		5/3-way valve, normally open						
VL-5/3E		5/3-way valve, normally exhausted						

Technical data

Technical data		Download CAD data → www.festo.com					
ISO size		1			2		
Valve function		5/2-way single solenoid	5/2-way double solenoid	5/3-way closed	5/2-way single solenoid	5/2-way double solenoid	5/3-way closed
Sub-base	1, 2, 3, 4, 5	G1/4			G3/8		
Pilot air	12, 14	G1/8			G1/8		
Type of mounting		Via through-hole on sub-base					
Electrical data – N1 solenoid coil							
Electrical connection		Plug type A					
Operating voltage	[V DC]	12, 24					
	[V AC]	24, 110, 230 (50 ... 60 Hz)					
Power consumption	DC	[W]	2.5				
	AC	[VA]	Pull: 7.5 Hold: 5				
Protection class to EN 60529		With plug socket to IP65					

Operating conditions

Operating medium	Compressed air to ISO 8573-1:2010 [7:4:4]
Note on operating/pilot medium	Lubricated operation possible (in which case lubricated operation will always be required)
Ambient temperature	[°C] -10 ... +50
Temperature of medium	[°C] -10 ... +50

Materials

Housing	Die cast aluminium
Seals	NBR

Solenoid valves MN1H/JMN1H, to ISO 5599-1

Technical data – 5/2-way valve, single solenoid

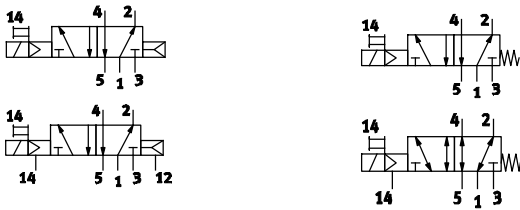

Technical data			Download CAD data → www.festo.com			
ISO size			1		2	
Reset method			Mechanical	Pneumatic	Mechanical	Pneumatic
Operating pressure	Internal pilot air supply	[bar]	3 ... 10	2 ... 10	3 ... 10	2 ... 10
	External pilot air supply	[bar]	-0.9 ... +16			
Pilot pressure		[bar]	3 ... 10	2 ... 10	3 ... 10	2 ... 10
Standard nominal flow rate	qnN	[l/min]	1,200		2,300	
Switching time	On/off	[ms]	17/39	23/32	24/62	46/69
Design	Piston spool valve					
Length/width/height		[mm]	128/42/74	118/42/74	162/54/84	148/54/84

Technical data – 5/2-way valve, double solenoid

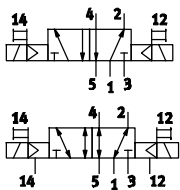

Technical data			Download CAD data → www.festo.com			
ISO size			1		2	
Operating pressure	Internal pilot air supply	[bar]	2 ... 10			
	External pilot air supply	[bar]	-0.9 ... +16			
Pilot pressure		[bar]	2 ... 10			
Standard nominal flow rate	qnN	[l/min]	1,200		2,300	
Switching time	Changeover	[ms]	18		21	
Design	Piston spool valve					
Length/width/height		[mm]	148/42/74		165/54/84	

Technical data – 5/3-way valve, normally closed

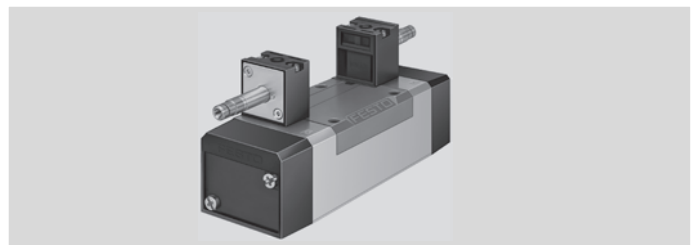
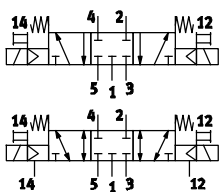

Technical data			Download CAD data → www.festo.com			
ISO size			1		2	
Operating pressure	Internal pilot air supply	[bar]	2 ... 10			
	External pilot air supply	[bar]	-0.9 ... +16			
Pilot pressure		[bar]	2 ... 10			
Standard nominal flow rate	qnN	[l/min]	1,200		2,300	
Switching time	On/off	[ms]	18/44		33/82	
Design	Piston spool valve					
Length/width/height		[mm]	148/42/74		165/54/84	

Technical data

Technical data		Download CAD data → www.festo.com					
ISO size		1		2			
Valve function		5/2-way single solenoid	5/2-way double solenoid	5/3-way closed	5/2-way single solenoid	5/2-way double solenoid	5/3-way closed
Sub-base	1, 2, 3, 4, 5	G $\frac{1}{4}$			G $\frac{3}{8}$		
Type of mounting		Via through-hole on sub-base					
Electrical data – EB solenoid coil							
Electrical connection		Plug M1 2x1					
Operating voltage	[V DC]	24					
Power consumption	DC [W]	2.5					
Protection class to EN 60529		With plug socket to IP65					

Operating conditions

Operating medium		Compressed air to ISO 8573-1:2010 [7:4:4]
Note on operating/pilot medium		Lubricated operat. possible (in which case lubricated operat. will always be required)
Ambient temperature	[°C]	-5 ... +50
Temperature of medium	[°C]	-5 ... +50

Materials

Housing	Die-cast aluminium
Seals	NBR

Technical data – 5/2-way valve, single solenoid

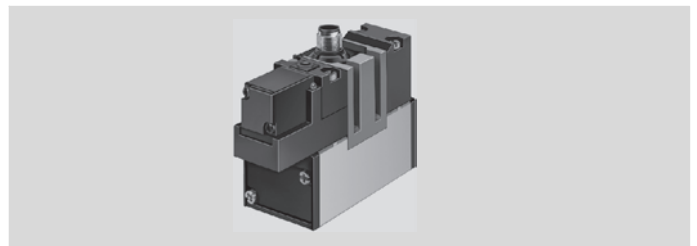
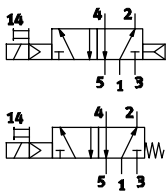

Technical data		Download CAD data → www.festo.com			
ISO size		1		2	
Reset method		Mechanical	Pneumatic	Mechanical	Pneumatic
Operating pressure	[bar]	3 ... 10	2 ... 10	3 ... 10	2 ... 10
Standard nominal flow rate	qnN [l/min]	1,200		2,300	
Switching time	On/off [ms]	15/50	20/33	33/103	50/85
Design		Piston spool valve			
Length/width/height	[mm]	122/42/81	111/42/81	155/54/91	138/54/91

Technical data – 5/2-way valve, double solenoid

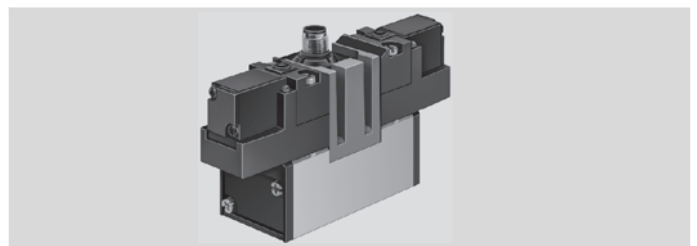
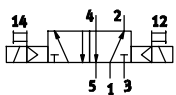

Technical data		Download CAD data → www.festo.com	
ISO size		1	2
Operating pressure	[bar]	2 ... 10	
Standard nominal flow rate	qnN [l/min]	1,200	2,300
Switching time	Changeover [ms]	12	15
Design		Piston spool valve	
Length/width/height	[mm]	134/42/81	152/54/91

Solenoid valves MEBH/JMEBH, to ISO 5599-1

Technical data – 5/3-way valve, normally closed

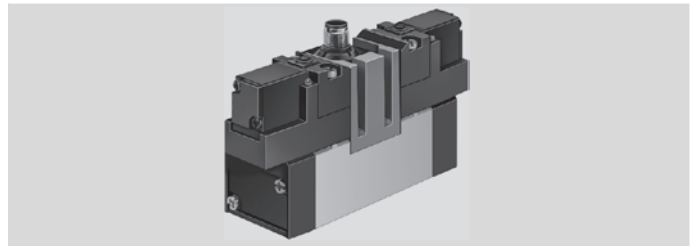
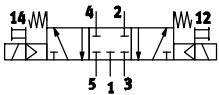

Technical data		Download CAD data → www.festo.com	
ISO size		1	2
Operating pressure	[bar]	2 ... 10	
Pilot pressure	[bar]	2 ... 10	
Standard nominal flow rate	q _{nN} [l/min]	1,200	2,300
Switching time	On/off [ms]	19/68	30/106
Design		Piston spool valve	
Length/width/height	[mm]	134/42/81	152/54/91

Order code

		D		ZSR		C
Solenoid valve						
MEBH	5/2-way valve, single solenoid 5/3-way valve					
JMEBH	5/2-way valve, double solenoid					
Valve function						
5/2	5/2-way valve					
5/3G	5/3-way valve, normally closed					
Standard identification						
D	Standard identification D					
Size						
1	ISO size 1					
2	ISO size 2					
Electrical connection						
ZSR	Round central plug, M12x1, 24 V DC					
Reset method for 5/2-way valve, single solenoid						
-	Pneumatic spring					
FR	Mechanical spring ^[1]					
Generation						
C	C series					

[1] Only for 5/2-way valves, single solenoid.

Ordering – Product options

	<p>Configurable product</p>	<p>This product and all its options can be ordered using the configurator.</p>	<p>The configurator can be found under Products on the DVD or → www.festo.com/catalogue/...</p>	<p>Enter the type code in the search field.</p>
---	------------------------------------	---	--	---

Technical data

Technical data		Download CAD data → www.festo.com							
ISO size		1				2			
Valve function		2x 3/2-way single solenoid	5/2-way single solenoid	5/2-way double solenoid	5/3-way single solenoid	2x 3/2-way single solenoid	5/2-way single solenoid	5/2-way double solenoid	5/3-way single solenoid
Sub-base	1, 2, 3, 4, 5 12, 14	G $\frac{1}{4}$ M5				G $\frac{3}{8}$ G $\frac{1}{8}$			
Type of mounting		On sub-base							
Electrical data – Solenoid coil									
Electrical connection									
Central plug, round design M12x1, 3-pin									
Operating voltage		[V DC]	24						
Power consumption	DC	[W]	1.3	1.6	4.6				
Protection class	With plug socket to IP65 (to EN 60529) and NEMA4								
Protective circuit and LED	Integrated in the valve								

Operating conditions

Operating medium	Compressed air to ISO 8573-1:2010 [7:4:4]								
Note on operating/pilot medium	Lubricated operation possible (in which case lubricated operation will always be required)								
Ambient temperature	[°C]	-5 ... +50							

Materials

Housing	Die-cast aluminium, PA								
Screws	Galvanised steel								
Seals	FPM, HNBR, NBR								

Technical data – 2x 3/2-way valve

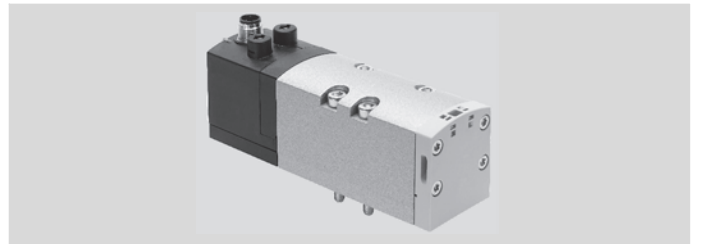
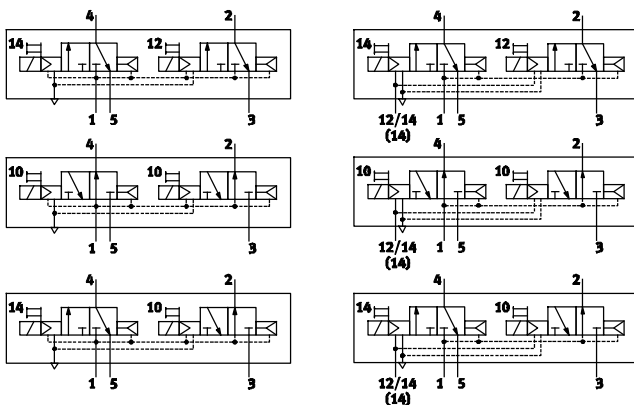

Technical data		Download CAD data → www.festo.com							
ISO size		1				2			
Reset method		Pneumatic							
Operating pressure	Internal pilot air supply	[bar]	3 ... 10						
	External pilot air supply	[bar]	3 ... 10						
Pilot pressure ¹⁾		[bar]	3 ... 10						
Standard nominal flow rate	qnN	[l/min]	1,100				2,200		
Switching time	On/off	[ms]	20/38				20/35		
Design	Piston spool valve								
Length/width/height		[mm]	138/42/59				160/52/60		

1) Minimum pilot pressure 50% of operating pressure

Solenoid valves VSVA, to ISO 5599-1

Technical data – 5/2-way valve, single solenoid

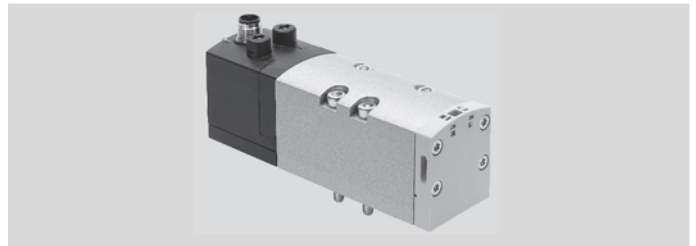
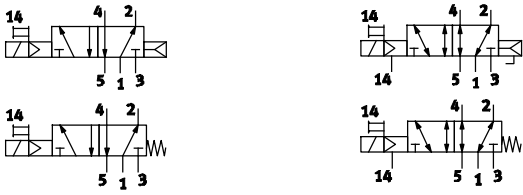

Technical data		Download CAD data → www.festo.com			
ISO size		1			2
Reset method		Mechanical	Pneumatic	Mechanical	Pneumatic
Operating pressure	Internal pilot air supply	[bar]	3 ... 10		
	External pilot air supply	[bar]	-0.9 ... 10		
Pilot pressure ¹⁾		[bar]	3 ... 10		
Standard nominal flow rate	qnN	[l/min]	1,300		2,800
Switching time	On/off	[ms]	22/60	27/45	20/60 40/45
Design		Piston spool valve			
Length/width/height		[mm]	138/42/59		160/52/60

1) Minimum pilot pressure 50% of operating pressure

Technical data – 5/2-way valve, double solenoid

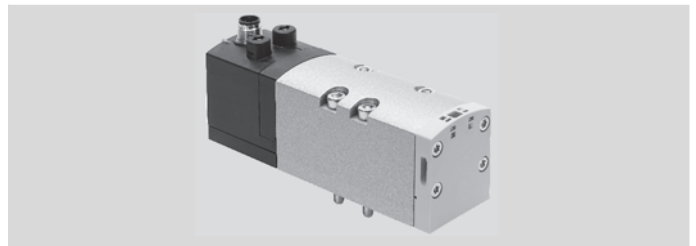
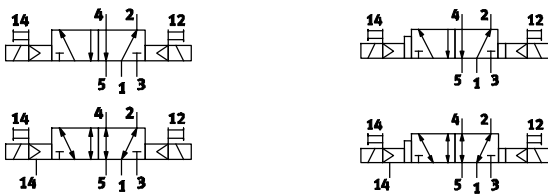

Technical data		Download CAD data → www.festo.com			
ISO size		1			2
Operating pressure	Internal pilot air supply	[bar]	3 ... 10		
	External pilot air supply	[bar]	-0.9 ... 10		
Pilot pressure ¹⁾		[bar]	3 ... 10		
Standard nominal flow rate	qnN	[l/min]	1,300		2,800
Changeover time	Dominance at 1st signal	[ms]	16		18
	Dominant signal at 14		19		18
Design		Piston spool valve			
Length/width/height		[mm]	138/42/59		160/52/60

1) Minimum pilot pressure 50% of operating pressure

Technical data – 5/3-way valve

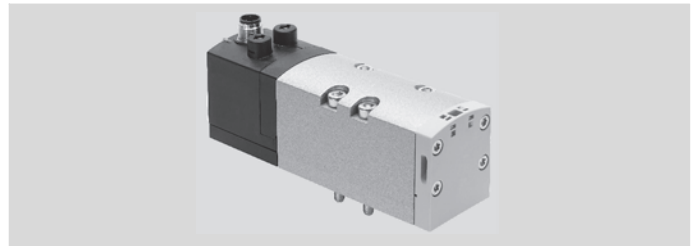
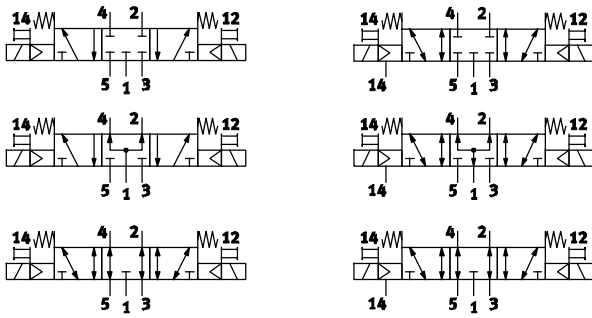

Technical data			Download CAD data → www.festo.com	
ISO size			1	2
Reset method			Mechanical	–
Operating pressure	Internal pilot air supply	[bar]	3 ... 10	
	External pilot air supply	[bar]	–0.9 ... 10	
Pilot pressure ¹⁾		[bar]	3 ... 10	
Standard nominal flow rate	qnN	[l/min]	1,300	2,700
Switching time	On/off	[ms]	22/65	23/60
Design			Piston spool valve	
Length/width/height		[mm]	138/42/59	160/52/60

1) Minimum pilot pressure 50% of operating pressure

Solenoid valves VSVA, to ISO 5599-1

Order code – 2x 3/2-way valve

		V S V A	-	B	-	T	3 2	-	A	D	-	1	R 5	L
Valve series														
VSVA	Standard valve to ISO 5599-1													
Valve type														
B	Sub-base valve													
Valve function														
T	2 single solenoid valves in one housing													
Ports/switching positions														
32	3/2-way valve													
Normal position/additional function														
C	Closed													
U	Open													
H	1x open, 1x closed													
Reset method														
A	Pneumatic spring													
Pilot air supply														
-	Internal													
Z	External													
Manual override														
D	Non-detenting/detenting													
Standard														
D1	ISO size 1, width 42 mm													
D2	ISO size 2, width 52 mm													
Operating voltage														
1	24 V DC													
Electrical connection														
R5	Central plug M12x1													
Signal status display														
L	LED (integrated)													

8

Ordering – Product options

	<p>Configurable product</p>	<p>This product and all its options can be ordered using the configurator.</p>	<p>The configurator can be found under Products on the DVD or www.festo.com/catalogue/...</p>	<p>Enter the type code in the search field.</p>
---	------------------------------------	---	---	---

Order code – 5/2-way valve

VSVA		B	52	D	1	R5	L
Valve series							
VSVA	Standard valve to ISO 5599-1						
Valve type							
B	Sub-base valve						
Valve function							
M	Single solenoid						
B	Double solenoid						
D	Double solenoid with dominant signal at 14						
Ports/switching positions							
52	5/2-way valve						
Reset method							
A	Pneumatic spring						
M	Mechanical spring						
-	Double solenoid valve						
Pilot air supply							
-	Internal						
Z	External						
Manual override							
D	Non-detenting/detenting						
Standard							
D1	ISO size 1, width 42 mm						
D2	ISO size 2, width 52 mm						
Operating voltage							
1	24 V DC						
Electrical connection							
R5	Central plug M12x1						
Signal status display							
L	LED (integrated)						

Ordering – Product options

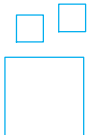

Configurable product

This product and all its options can be ordered using the configurator.

The configurator can be found under Products on the DVD or
[→ www.festo.com/catalogue/...](http://www.festo.com/catalogue/...)

Enter the type code in the search field.

★ Quick ordering

		Part No.	Type
5/2-way single solenoid valve	Pneumatic reset method	561362	VSVA-B-M52-AD-D1-1R5L
	Mechanical spring reset method	561363	VSVA-B-M52-MD-D1-1R5L
5/2-way double solenoid valve	Dominance at 1st signal	561364	VSVA-B-B52-D-D1-1R5L

Solenoid valves VSVA, to ISO 5599-1

Order code – 5/3-way valve

		VSPA	-	B	-	P	53	-	D	-	1	R5	L
Valve series													
VSPA	Standard valve to ISO 5599-1												
Valve type													
B	Sub-base valve												
Valve function													
P	Single solenoid, mid-position												
Ports/switching positions													
53	5/3-way valve												
Normal position/additional function													
C	Closed												
U	Open												
E	Exhausted												
Pilot air supply													
-	Internal												
Z	External												
Manual override													
D	Non-detenting/detenting												
Standard													
D1	ISO size 1, width 42 mm												
D2	ISO size 2, width 52 mm												
Operating voltage													
1	24 V DC												
Electrical connection													
R5	Central plug M12x1												
Signal status display													
L	LED (integrated)												

8

Ordering – Product options

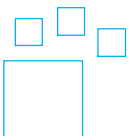

Configurable product

This product and all its options can be ordered using the configurator.

The configurator can be found under Products on the DVD or
 → www.festo.com/catalogue/...

Enter the type code in the search field.

Technical data

Technical data			Download CAD data → www.festo.com			
ISO size	1			2		
Valve function	5/2-way single solenoid	5/2-way double solenoid	5/3-way exhausted	5/2-way single solenoid	5/2-way double solenoid	5/3-way exhausted
Sub-base	1, 2, 3, 4, 5			G $\frac{1}{4}$		G $\frac{3}{8}$
Type of mounting	Via through-hole on sub-base					
Electrical data – F solenoid coil						
Electrical connection	Plug vanes for plug sockets MSSD-F, KMF					
Operating voltage	DC voltage	[V DC]	12, 24, 42, 48			
	AC voltage	[V AC]	24, 42, 48, 110, 230, 240 (50 ... 60 Hz)			
Coil characteristics	DC voltage	[W]	4.5			
	AC voltage	[VA]	Pull: 7.5 Hold: 6			
Protection class to EN 60529	With plug socket to IP65					

Operating conditions

Operating medium	Compressed air to ISO 8573-1:2010 [7:4:4]					
Note on operating/pilot medium	Lubricated operation possible (in which case lubricated operation will always be required)					
Ambient temperature	[°C]	-5 ... +40				
Temperature of medium	[°C]	-10 ... +60				

Materials

Housing	Die cast aluminium					
Seals	NBR					

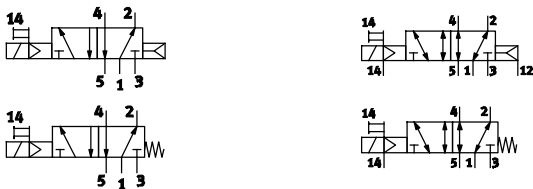
Technical data – 5/2-way valve, single solenoid

Technical data			Download CAD data → www.festo.com			
ISO size	1			2		
Reset method	Mechanical		Pneumatic		Pneumatic	
Operating pressure	Internal pilot air supply	[bar]	3 ... 10		3 ... 10	
	External pilot air supply	[bar]	-0.9 ... 16		-0.9 ... 16	
Standard nominal flow rate	q _{nN}	[l/min]	1,200		2,300	
Switching time	On/off	[ms]	16/45		27/73	
Design	Piston spool valve					
Length/width/height	[mm]	126/42/70	115/42/70	160/54/80	142/54/80	

Solenoid valves MFH/JMFH, to ISO 5599-1

Technical data – 5/2-way valve, double solenoid

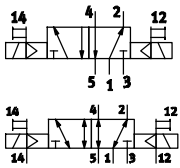

Technical data			Download CAD data → www.festo.com	
ISO size			1	2
Operating pressure	Internal pilot air supply	[bar]	2 ... 10	
	External pilot air supply	[bar]	-0.9 ... 16	
Standard nominal flow rate	qnN	[l/min]	1,200	2,300
Switching time	Changeover	[ms]	16	18
Design	Piston spool valve			
Length/width/height		[mm]	143/42/70	160/54/80

Technical data – 5/3-way valve, normally closed

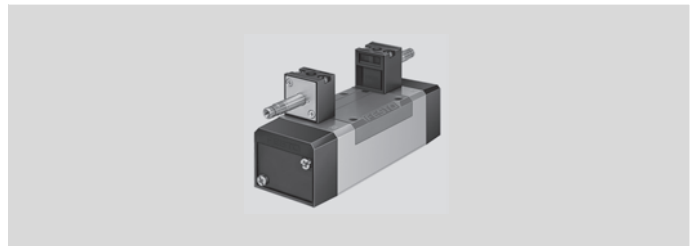
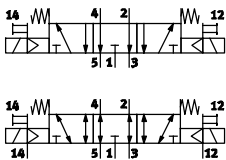

Technical data			Download CAD data → www.festo.com	
ISO size			1	2
Operating pressure	Internal pilot air supply	[bar]	3 ... 10	
	External pilot air supply	[bar]	-0.9 ... 16	
Pilot pressure		[bar]	2 ... 10	
Standard nominal flow rate	qnN	[l/min]	1,200	2,300
Switching time	On/off	[ms]	18/36	35/67
Design	Piston spool valve			
Length/width/height		[mm]	143/42/70	160/54/80

Solenoid valves, to ISO 5599-1

Accessories – Individual mounting

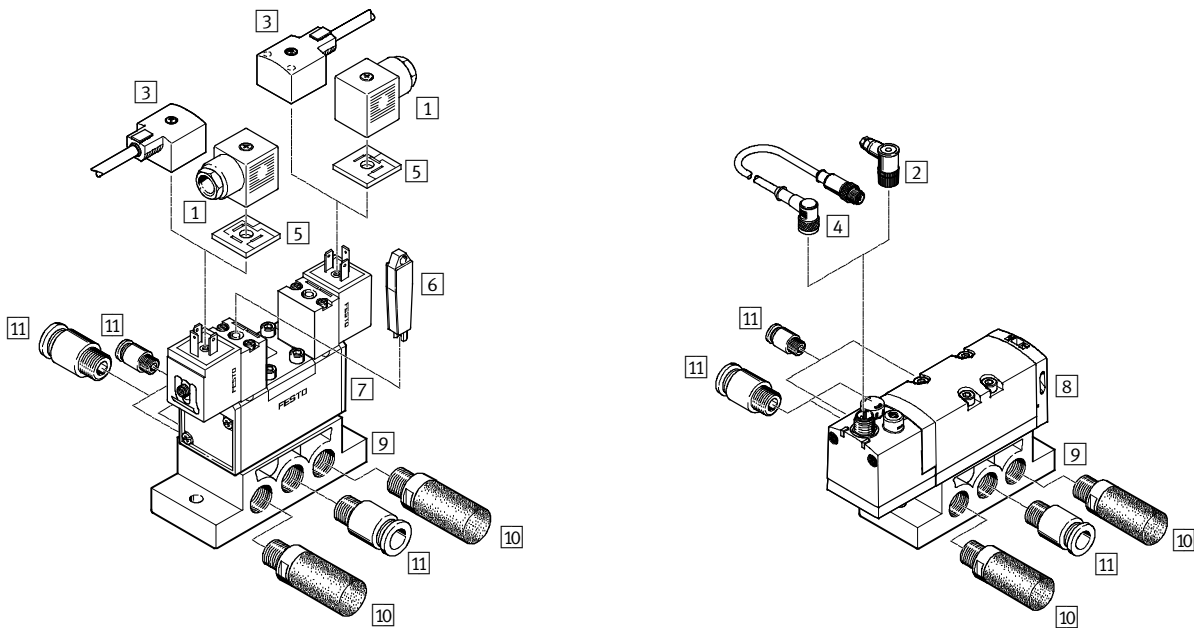

8

		→ Page/online
1	Angled plug socket MSSD, square design	567
2	Plug socket SAE for plug M12x1	567
3	Plug socket with cable KMC for plug type A	567
4	Connecting cable KM12-M12 for plug M12x1	567
5	Illuminating seal M...-LD for N1 solenoid coil	567
6	Manual override AHB	567
7	Solenoid valve MN1H	551
8	Solenoid valve VSVA	555
9	Individual sub-base NAS	567
10	Silencer U	567
11	Push-in fitting QS	568
-	N1 solenoid coil	569
-	F solenoid coil	569
-	Inscription label IBS-9x17	569

Accessories – Manifold assembly

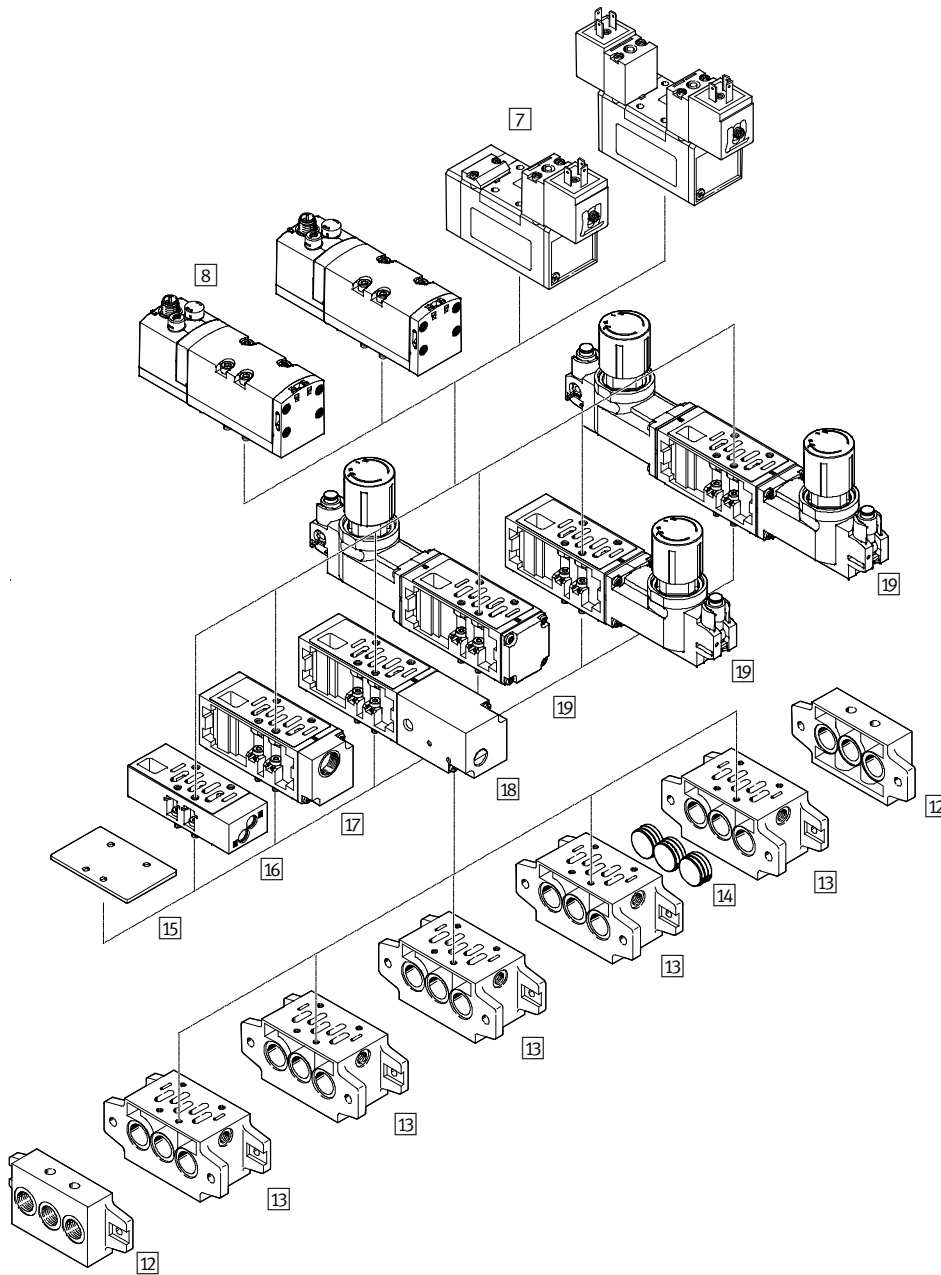

		→ Page/online
7	Solenoid valve MN1H	551
8	Solenoid valve VSVA	555
12	End plate kit NEV	568
13	Manifold sub-base NAV	568
14	Isolating disc NSC	568
15	Blanking plate NDV	568
16	Flow control plate VABF-S1-1-F1B1	568
17	Vertical supply plate VABF-S1-1-P1A3	568
18	Vertical pressure shut-off plate VABF-S1-1-L1D1	568
19	Regulator plate VABF-S1-1-R	569
-	N1 solenoid coil	569
-	F solenoid coil	569
-	Inscription label IBS-9x17	569

Solenoid valves, to ISO 5599-1



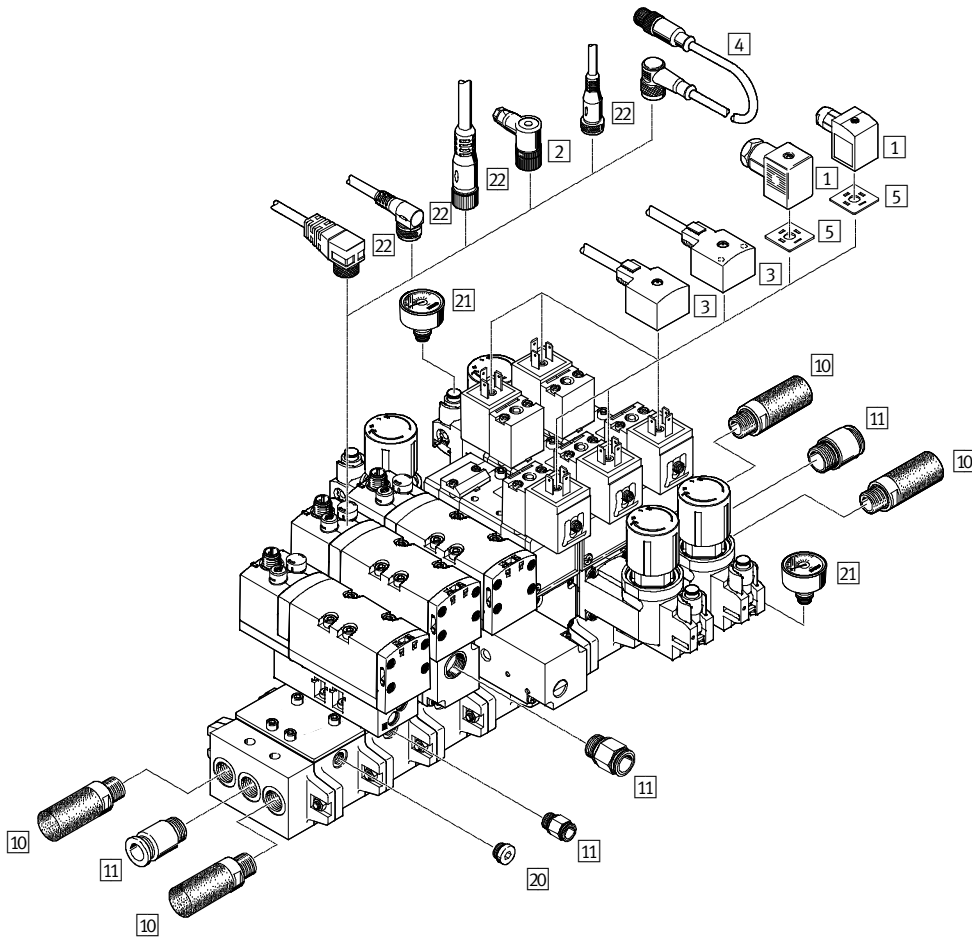



Accessories

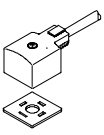
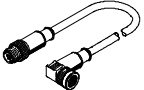

8

	→ Page/online	
1	Angled plug socket MSSD, square design	567
2	Plug socket SAE for plug M12x1	567
3	Plug socket with cable KMC for plug type A	567
4	Connecting cable KM1 2-M12 for plug M12x1	567
5	Illuminating seal M...LD for N1 solenoid coil	567
10	Silencer U	567
11	Push-in fitting QS	568
20	Blanking plug B	569
21	Pressure gauge PAGN-26-10-P10	569
22	Plug socket with cable NEBU-M12 for plug M12x1	569
-	N1 solenoid coil	569
-	F solenoid coil	569
-	Inscription label IBS-9x17	569

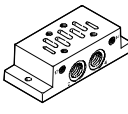

Accessories – Ordering data

	Description		Part No.	Type
1 Angled plug socket Technical data online: → mssd				
	For plug type A	Cable conduit fitting Pg9	Screw terminal	34583 MSSD-C
		Cable conduit fitting M16	Screw terminal	539709 MSSD-C-M16
		–	Insulation displacement connection	192748 MSSD-C-S-M16
	For F solenoid coil	Cable conduit fitting Pg9	Screw terminal	★ 34431 MSSD-F
2 Plug socket for plug M12x1 Technical data online: → sea				
	Angled socket, M12, 4-pin		Screw terminal	185498 SEA-M12-4WD-PG7
3 Plug socket with cable for plug type A Technical data online: → kmc				
	24 V DC	With LED	2.5 m	30931 KMC-1-24DC-2,5-LED
			5 m	30933 KMC-1-24DC-5-LED
			10 m	193459 KMC-1-24DC-10-LED
	Up to 230 V	Without LED	2.5 m	30932 KMC-1-230AC-2,5
			5 m	30934 KMC-1-230AC-5
4 Connecting cable for plug M12x1 Technical data online: → km12				
	Connecting cable, straight plug, angled socket	M12, 4-pin	1.0 m	185499 KM12 M12-GSWD-1-4
5 Illuminating seal for N1 solenoid coil				
	Illuminating seal	For N1 solenoid coils	12 ... 24 V DC	19145 MC-LD-12-24DC
			230 V DC/V AC	19146 MC-LD-230AC
6 Manual override				
	Tool for manual override	Valves MEBH	157601	AHB-MEB
		Valves MN1H/MFH-	157651	AHB-MD/MF/MV
9 Individual sub-base				
	For valves in 42 mm width	Ports at side	★ 9484	NAS-1/4-1A-ISO
		Ports underneath	★ 9485	NAU-1/4-1B-ISO
	For valves in 52 mm width	Ports at side	11310	NAS-3/8-2A-ISO
		Ports underneath	11416	NAU-3/8-2B-ISO
10 Silencer Technical data → 994				
	Silencer for noise reduction at exhaust ports	For thread G1/4	★ 6842	U-1/4-B
		For thread G3/8	★ 6843	U-3/8-B
		For thread G1/2	★ 6844	U-1/2-B



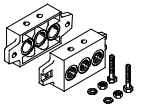
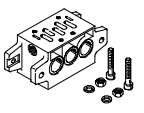

Solenoid valves, to ISO 5599-1

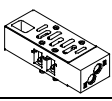
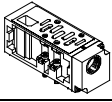
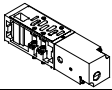
FESTO

Accessories – Ordering data

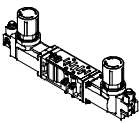
	Description		Part No.	Type	
11 Push-in fitting Technical data → 908					
	Connecting thread G1/8	Tubing O.D. 8 mm	10 pieces	★	186098 QS-G1/8-8
	Connecting thread G1/4	Tubing O.D. 8 mm	10 pieces	★	186099 QS-G1/4-8
	Connecting thread G3/8, plastic releasing ring	Tubing O.D. 10 mm	10 pieces	★	186102 QS-G3/8-10
	Connecting thread G1/2	Tubing O.D. 12 mm	1 piece	★	186104 QS-G1/2-12
12 End plate kit					
	Right-hand and left-hand end plate	For valves in 42 mm width		★	10174 NEV-1DA/DB-ISO
		For valves in 52 mm width		★	11306 NEV-2DA/DB-ISO
13 Manifold sub-base					
	One valve position	For valves in 42 mm width	Ports underneath	★	10173 NAV-1/4-1C-ISO
			Ports at side and underneath	★	152789 NAVW-1/4-1-ISO
		For valves in 52 mm width	Ports underneath		11305 NAV-3/8-2C-ISO
14 Isolating disc					
	For pressure zone separation	For valves in 42 mm width		★	11550 NSC-1/4-1-ISO
		For valves in 52 mm width			11908 NSC-3/8-2-ISO
15 Blanking plate					
	With seal and mounting screws	For valves in 42 mm width		★	9489 NDV-1-ISO
		For valves in 52 mm width			11308 NDV-2-ISO
16 Flow control plate					
	For exhaust air flow control in ports 3 and 5 of the valve	For valves in 52 mm width			555788 VABF-S1-2-F1B1-C
17 Vertical supply plate					
	For independently supplying working air to a valve	For valves in 52 mm width			555785 VABF-S1-2-P1A3-G12
18 Vertical pressure shut-off plate					
	For shutting off a valve from the supply pressure	For valves in 52 mm width			555790 VABF-S1-2-L1D1-C

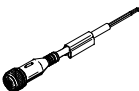
Accessories – Ordering data

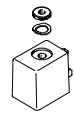
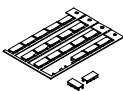
	Description	Part No.	Type			
19 Regulator plate, for valves in 52 mm width						
	For port 1	P	0.5 ... 10 bar	555758	VABF-S1-2-R1C2-C-10	
			0.5 ... 6 bar	555757	VABF-S1-2-R1C2-C-6	
	For port 2	B	0.5 ... 10 bar	555760	VABF-S1-2-R2C2-C-10	
			0.5 ... 6 bar	555759	VABF-S1-2-R2C2-C-6	
	For port 4	A	0.5 ... 10 bar	555762	VABF-S1-2-R3C2-C-10	
			0.5 ... 6 bar	555761	VABF-S1-2-R3C2-C-6	
	For port 2 and 4	AB	0.5 ... 10 bar	555764	VABF-S1-2-R4C2-C-10	
			0.5 ... 6 bar	555763	VABF-S1-2-R4C2-C-6	
	For port 2 and 4, reversible	AB	0.5 ... 10 bar	555766	VABF-S1-2-R5C2-C-10	
			0.5 ... 6 bar	555765	VABF-S1-2-R5C2-C-6	
	For port 2, reversible	B	0.5 ... 10 bar	555768	VABF-S1-2-R6C2-C-10	
			0.5 ... 6 bar	555767	VABF-S1-2-R6C2-C-6	
For port 4, reversible	A	0.5 ... 10 bar	555770	VABF-S1-2-R7C2-C-10		
		0.5 ... 6 bar	555769	VABF-S1-2-R7C2-C-6		
20 Blanking plug Technical data online: → b-1						
	For sealing ports	Connecting thread G1/4	10 pieces	3569	B-1/4	
		Connecting thread G3/8	10 pieces	3570	B-3/8	
21 Pressure gauge Technical data online: → pagn						
	With cartridge fitting connection for regulator plate	0 ... 10 bar	543488	PAGN-26-10-P10		
22 Plug socket with cable for plug M12x1 Technical data online: → nebu						
	Open cable end, 4-wire	Straight socket, 5-pin	2.5 m	550326	NEBU-M12G5-K-2.5-LE4	
			5 m	541328	NEBU-M12G5-K-5-LE4	
		Angled socket, 5-pin	5 m	541329	NEBU-M12W5-K-5-LE4	
N1 solenoid coil for valves MN1H, JMN1H						
	24 V DC			123060	MSN1G-24DC-OD	
	12 V DC and 24 V AC, 50 ... 60 Hz			170152	MSN1W-24AC/12DC	
	110 V AC, 50 ... 60 Hz			123061	MSN1W-110AC-OD	
	230 V AC, 50 ... 60 Hz			123062	MSN1W-230AC-OD	
F solenoid coil for valves MFH, JMFH						
	12 V DC			34410	MSFG-12DC-OD	
	24 V DC and 42 V AC, 50 ... 60 Hz, plug vanes with connection pattern to Festo standard for MSSD-F			★	4527	MSFG-24/42-50/60
				★	34411	MSFG-24/42-50/60-OD
	24 V DC and 42 V AC, 50 ... 60 Hz, electrical connection to DIN EN 175301-803			★	34412	MSFG-24/42-50/60-DS-OD
	42 V DC			34413	MSFG-42DC-OD	
	24 V AC			34415	MSFG-24AC-OD	
	48 V AC, 50 ... 60 Hz			34418	MSFW-48AC-OD	
	110 V AC, 50 ... 60 Hz and 120 V AC, 60 Hz			34420	MSFW-110AC-OD	
	230 V AC, 50 ... 60 Hz and 240 V AC, 60 Hz			34422	MSFW-230AC-OD	
	240 V AC, 50 ... 60 Hz			34424	MSFW-240AC-OD	
	Inscription label					
	Inscription label for valves	24 pieces in frame	161937	IBS-9x17		

Solenoid valves VUVG

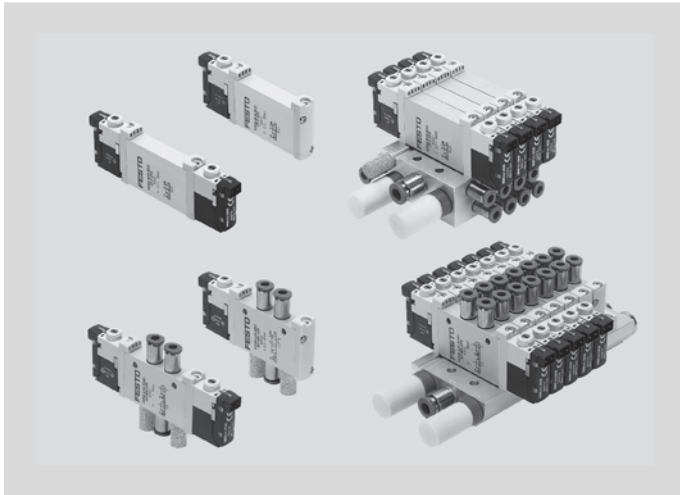

- Universal valve
- Combination of basic valves and connection options
- Width 10 mm and 14 mm
- In-line valves VUVG-L and VUVG-S
- Sub-base valves VUVG-B
- Internal or external pilot air supply
- Can be mounted as individual valve or sub-base valve on sturdy aluminium manifold rail
- ★ Quick ordering of basic designs → 575, 581, 587, 593

→ www.festo.com/catalogue/vuvg

Product range overview

Type	Design	Working port	Valve functions and flow rate [l/min]													→ Page/ online
			T32C-A	T32U-A	T32H-A	T32C-M	T32U-M	T32H-M	M52-A	M52-M	M52-R	B52	P53C	P53U	P53E	
VUVG-L	In-line valve	M3 (10A)	–	–	–	–	–	–	–	80	100	100	90	90	90	vuvg
		M5 (10)	150	150	150	135	125	125	–	190	220	220	210	210	210	575
		M7 (10)	190	190	190	150	140	140	–	320	380	380	320	320	320	575
		G1/8 (14)	650	600	650	550	500	500	780	780	–	780	650	600	600	600
VUVG-S	In-line valve for manifold assembly	M3 (10A)	–	–	–	–	–	–	–	80	100	100	90	90	90	vuvg
		M5 (10)	150	150	150	135	125	125	–	190	220	220	210	210	210	575
		M7 (10)	170	170	170	140	130	130	–	290	340	340	300	300	300	575
		G1/8 (14)	620	580	580	520	480	480	730	730	–	730	620	580	580	580
VUVG-B	Sub-base valve	M3 (10A)	–	–	–	–	–	–	–	80	100	100	90	90	90	vuvg
		M5 (10)	150	150	150	130	120	120	–	180	210	210	200	200	200	587
		M7 (10)	160	160	160	140	130	130	–	230	270	270	250	250	250	587
		G1/8 (14)	540	510	540	430	410	410	580	580	–	580	540	510	510	510

Valve functions:

- T32C-A 2x3/2-way valve, normally closed, pneumatic spring
- T32U-A 2x3/2-way valve, normally open, pneumatic spring
- T32H-A 2x3/2-way valve, 1x normally closed, 1x normally open, pneumatic spring
- T32C-M 2x3/2-way valve, normally closed, mechanical spring
- T32U-M 2x3/2-way valve, normally open, mechanical spring
- T32H-M 2x3/2-way valve, 1x normally closed, 1x normally open, mechanical spring
- M52-A 5/2-way valve, single solenoid, pneumatic spring
- M52-M 5/2-way valve, single solenoid, mechanical spring
- M52-R 5/2-way valve, single solenoid, pneumatic/mechanical spring
- B52 5/2-way valve, double solenoid
- P53C 5/3-way valve, mid-position closed
- P53U 5/3-way valve, mid-position pressurised
- P53E 5/3-way valve, mid-position exhausted

Technical data

Technical data		Download CAD data → www.festo.com									
Valve function		T32-A			T32-M			M52-R	B52	M52-M	P53
Normal position		C ¹⁾	U ²⁾	H ⁴⁾	C ¹⁾	U ²⁾	H ⁴⁾	–	–	–	C ¹⁾ U ²⁾ E ³⁾
Pneumatic spring reset method		Yes			No			Yes ⁵⁾	–	No	No
Mechanical spring reset method		No			Yes			Yes ⁵⁾	–	Yes	Yes
Connection: In-line valve	1, 2, 3, 4, 5 12, 14	M5, M7 M3									
Vacuum operation at port 1		No			Only with external pilot air supply						
Design		Piston spool valve									
Type of mounting		Via through-holes ⁶⁾									
Electrical connection		Via connecting plate									
Nominal operating voltage	[V DC]	5, 12 and 24 ±10%									
Power	[W]	1, reduced to 0.35 with holding current reduction									
Duty cycle	[%]	100									
Protection class to EN 60529		IP40 (with plug socket), IP65 (with M8)									

- 1) C = Normally closed
- 2) U = Normally open
- 3) E = Normally exhausted
- 4) H=2x 3/2-way valve in one housing with 1x normally closed and 1x normally open
- 5) Combined reset method
- 6) If several valves are to be screwed together via the through-holes to form a block, a minimum gap of 0.3 mm must be ensured by placing spacer discs between them.

Operating conditions	
Operating medium	Compressed air to ISO 8573-1:2010 [7:4:4]
Note on operating/pilot medium	Lubricated operation possible (in which case lubricated operation will always be required)
Ambient temperature	[°C] -5 ... +50, -5 ... +60 with holding current reduction
Temperature of medium	[°C] -5 ... +50, -5 ... +60 with holding current reduction

Materials		Download CAD data → www.festo.com
Housing	Wrought aluminium alloy	
Seals	HNBR, NBR	

Technical data – 2x3/2-way valve

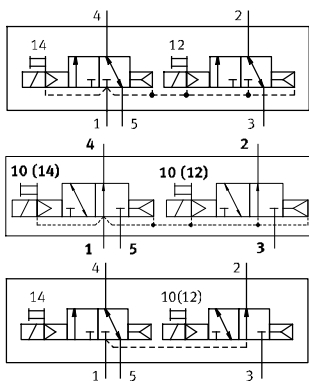

Normally closed, internal or external pilot air supply

Normally open, internal or external pilot air supply

1x normally closed,
1x normally open,
internal or external pilot air supply

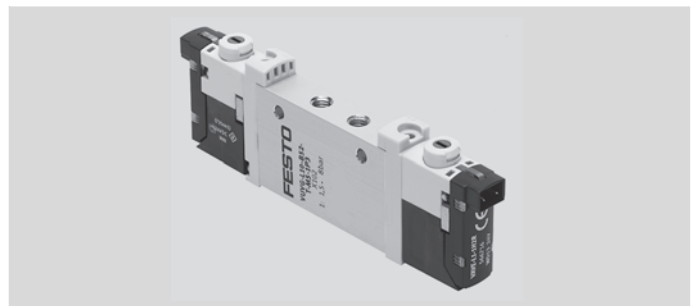

Technical data		Download CAD data → www.festo.com	
Valve function		T32-A	T32-M
Operating pressure	Internal	[bar] 1.5 ... 8	2.5 ... 8
	External	[bar] 1.5 ... 10	-0.9 ... 10
Pilot pressure ⁷⁾	[bar]	1.5 ... 8	2 ... 8
Standard nominal flow rate M5	[l/min]	150	125 ... 135
Flow rate on manifold rail M5	[l/min]	150	125 ... 135
Standard nominal flow rate M7	[l/min]	190	140 ... 150
Flow rate on manifold rail M7	[l/min]	170	130 ... 140
Switching time on/off	[ms]	6/16	8/11

7) Minimum pilot pressure 50% of operating pressure

Solenoid valves VUVG-L10 and VUVG-S10, in-line valves M5/M7

Technical data – 5/2-way valve, single solenoid

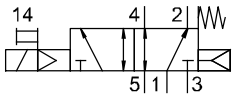

Internal or external pilot air supply

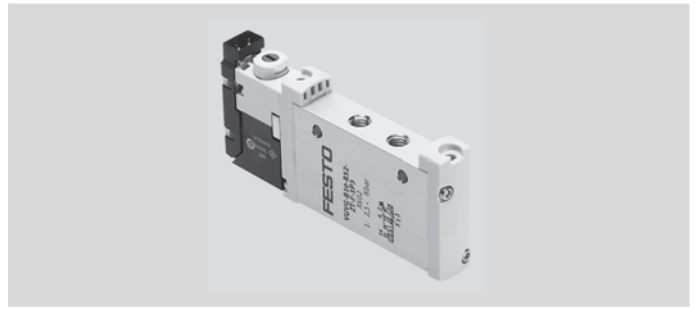

Technical data			Download CAD data → www.festo.com	
Valve function			M52-R	M52-M
Operating pressure	Internal	[bar]	2.5 ... 8	3 ... 8
	External	[bar]	-0.9 ... 10	-0.9 ... 8
Pilot pressure ¹⁾		[bar]	2.5 ... 8	3 ... 8
Standard nominal flow rate M5		[l/min]	220	190
Flow rate on manifold rail M5		[l/min]	220	190
Standard nominal flow rate M7		[l/min]	380	320
Flow rate on manifold rail M7		[l/min]	340	290
Switching time on/off		[ms]	7/19	8/24

1) Minimum pilot pressure 50% of operating pressure

8

Technical data – 5/2-way valve, double solenoid

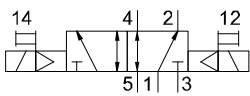

Internal or external pilot air supply

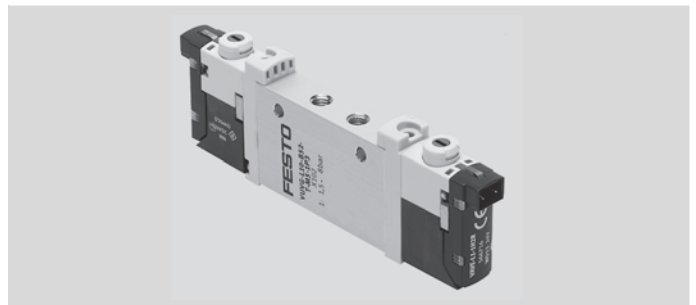

Technical data			Download CAD data → www.festo.com	
Valve function			B52	
Operating pressure	Internal	[bar]	1.5 ... 8	
	External	[bar]	-0.9 ... 10	
Pilot pressure ²⁾		[bar]	1.5 ... 8	
Standard nominal flow rate M5		[l/min]	220	
Flow rate on manifold rail M5		[l/min]	220	
Standard nominal flow rate M7		[l/min]	380	
Flow rate on manifold rail M7		[l/min]	340	
Changeover time		[ms]	7	

2) Minimum pilot pressure 50% of operating pressure

Technical data – 5/3-way valve

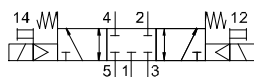

Normally closed,
internal or external pilot air supply

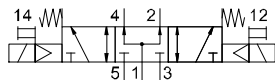

Normally open,
internal or external pilot air supply

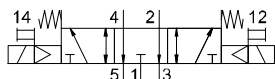

Normally exhausted,
internal or external pilot air supply

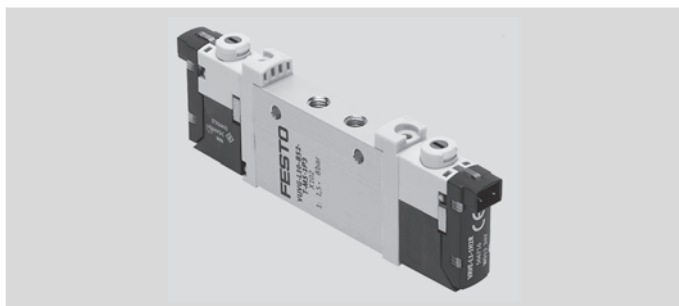

Technical data

Download CAD data → www.festo.com

Valve function		P53
Operating pressure	Internal	[bar] 3 ... 8
	External	[bar] -0.9 ... 10
Pilot pressure ¹⁾		[bar] 3 ... 8
Standard nominal flow rate M5		[l/min] 210
Flow rate on manifold rail M5		[l/min] 210
Standard nominal flow rate M7		[l/min] 320
Flow rate on manifold rail M7		[l/min] 300
Switching time on/off		[ms] 10/30
Changeover time		[ms] 16

1) Minimum pilot pressure 50% of operating pressure

Ordering – Product options



Configurable product

This product and all its options can be ordered using the configurator.

The configurator can be found under Products on the DVD or
[→ www.festo.com/catalogue/...](http://www.festo.com/catalogue/...)

Enter the type code in the search field.

★ Quick ordering

Part No.	Type
In-line valve M5, 3/2-way valve	
566454	VUVG-L10-T32C-AT-M5-1P3
566463	VUVG-L10-T32C-AZT-M5-1P3
In-line valve M5, 5/2-way single solenoid valve	
566457	VUVG-L10-M52-RT-M5-1P3
566466	VUVG-L10-M52-RZT-M5-1P3
574351	VUVG-L10-M52-MT-M5-1P3
In-line valve M5, 5/2-way double solenoid valve	
566458	VUVG-L10-B52-T-M5-1P3
566467	VUVG-L10-B52-ZT-M5-1P3
In-line valve M5, 5/3-way valve	
566459	VUVG-L10-P53C-T-M5-1P3
566468	VUVG-L10-P53C-ZT-M5-1P3

Part No.	Type
In-line valve M7, 3/2-way valve	
566471	VUVG-L10-T32C-AT-M7-1P3
566479	VUVG-L10-T32C-AZT-M7-1P3
In-line valve M7, 5/2-way single solenoid valve	
566474	VUVG-L10-M52-RT-M7-1P3
566482	VUVG-L10-M52-RZT-M7-1P3
In-line valve M7, 5/2-way double solenoid valve	
566475	VUVG-L10-B52-T-M7-1P3
566483	VUVG-L10-B52-ZT-M7-1P3
In-line valve M7, 5/3-way valve	
566476	VUVG-L10-P53C-T-M7-1P3
566484	VUVG-L10-P53C-ZT-M7-1P3

Solenoid valves VUVG-L10 and VUVG-S10, in-line valves M5/M7

Accessories – Ordering data



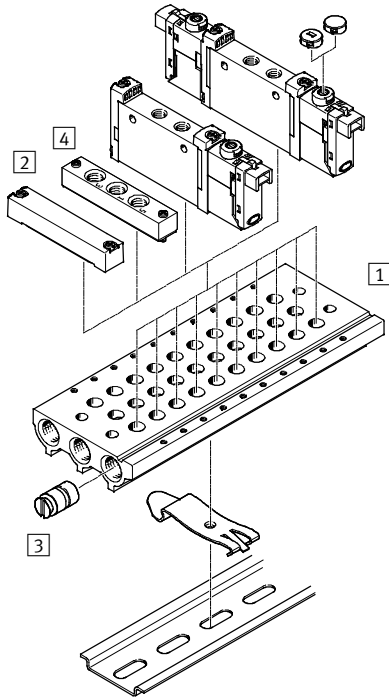

Order code – Manifold rails

VABM	-	L1	-	10	S	-	G18	-
Manifold assembly parts								
Manifold rail	VABM							
Valve series								
VUVG	L1							
Valve width								
10 mm			10					
Manifold rail with ports 1, 3, 5								
For M5 and M7 in-line valves			S					
						Number of valve positions		
						2 to 10, 12, 14 and 16		
						Ports 1, 3, 5		
						G18 G1/8		

Manifold assembly

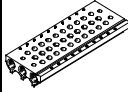

8

		Part No.	Type
1 Manifold rail			
	For M5/M7	★ 566558	VABM-L1-10S-G18-2
		★ 566559	VABM-L1-10S-G18-3
		★ 566560	VABM-L1-10S-G18-4
		★ 566561	VABM-L1-10S-G18-5
		★ 566562	VABM-L1-10S-G18-6
		566563	VABM-L1-10S-G18-7
		★ 566564	VABM-L1-10S-G18-8
		566565	VABM-L1-10S-G18-9
		★ 566566	VABM-L1-10S-G18-10
		★ 566567	VABM-L1-10S-G18-12
	566568	VABM-L1-10S-G18-14	
	566569	VABM-L1-10S-G18-16	
2 Blanking plate			
	For M5/M7	★ 566462	VABB-L1-10S
3 Blanking plug			
	Separator for pressure zones	★ 569995	VABD-8-B
4 Supply plate			
	For M5	★ 569991	VABF-L1-10-P3A4-M5
	For M7	★ 569992	VABF-L1-10-P3A4-M7
Seals for in-line valves (10 pieces incl. 20 screws)			
	For M5	★ 566672	VABD-L1-10X-S-M5
	For M7	★ 566673	VABD-L1-10X-S-M7

Technical data

Technical data		Download CAD data → www.festo.com											
Valve function		T32-A			T32-M			M52-A	B52	M52-M	P53		
Normal position		C ¹⁾	U ²⁾	H ⁴⁾	C ¹⁾	U ²⁾	H ⁴⁾	–	–	–	C ¹⁾	U ²⁾	E ³⁾
Pneumatic spring reset method		Yes			No			Yes	–	No	No		
Mechanical spring reset method		No			Yes			No	–	Yes	Yes		
Connection: In-line valve	1, 2, 3, 4, 5 12, 14	G1/8											
		M5											
Vacuum operation at port 1		No			Only with external pilot air supply								
Design		Piston spool valve											
Type of mounting		Via through-holes ⁵⁾											
Electrical connection		Via connecting plate											
Nominal operating voltage	[V DC]	5, 12 and 24 ±10%											
Power	[W]	1, reduced to 0.35 with holding current reduction											
Duty cycle	[%]	100											
Protection class to EN 60529		IP40 (with plug socket), IP65 (with M8)											

1) C = Normally closed

2) U = Normally open

3) E = Normally exhausted

4) H=2x 3/2-way valve in one housing with 1x normally closed and 1x normally open

5) If several valves are to be screwed together via the through-holes to form a block, a minimum gap of 0.3 mm must be ensured by placing spacer discs between them.

Operating conditions

Operating medium		Compressed air to ISO 8573-1:2010 [7:4:4]
Note on operating/pilot medium		Lubricated operation possible (in which case lubricated operation will always be required)
Ambient temperature	[°C]	–5 ... +50, –5 ... +60 with holding current reduction
Temperature of medium	[°C]	–5 ... +50, –5 ... +60 with holding current reduction

Materials

Download CAD data → www.festo.com

Housing		Wrought aluminium alloy
Seals		HNBR, NBR

Technical data – 2x3/2-way valve

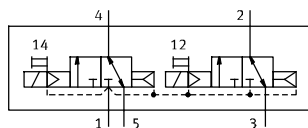
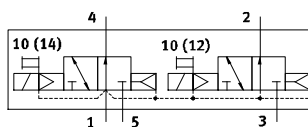
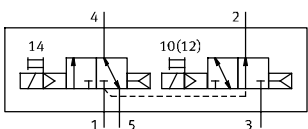
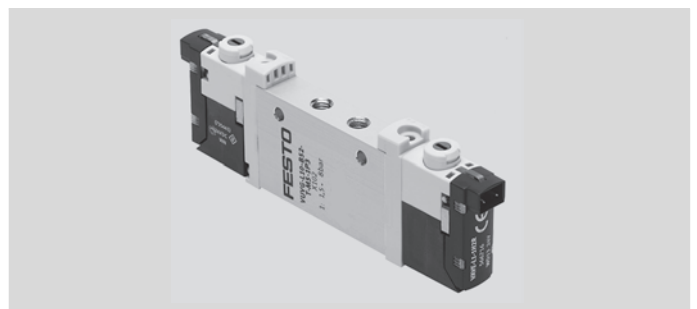
Normally closed (C),
internal or external pilot air supplyNormally open (U),
internal or external pilot air supply1x normally closed,
1x normally open (H),
internal or external pilot air supply

Technical data		Download CAD data → www.festo.com	
Valve function		T32-A	T32-M
Operating pressure	Internal [bar]	1.5 ... 8	3.5 ... 8
	External [bar]	1.5 ... 10	–0.9 ... 10
Pilot pressure ⁶⁾	[bar]	1.5 ... 8	2 ... 8
Standard nominal flow rate	[l/min]	600 ... 650	500 ... 550
Flow rate on manifold rail	[l/min]	580 ... 620	480 ... 520
Switching time on/off	[ms]	8/23	11/15

6) Minimum pilot pressure 50% of operating pressure

Solenoid valves VUVG-L14 and VUVG-S14, in-line valves G¹/₈

Technical data – 5/2-way valve, single solenoid

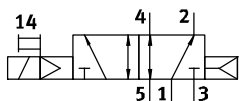

Internal or external pilot air supply



Technical data			Download CAD data → www.festo.com	
Valve function			M52-A	M52-M
Operating pressure	Internal	[bar]	2.5 ... 8	3 ... 8
	External	[bar]	-0.9 ... 10	-0.9 ... 8
Pilot pressure ¹⁾		[bar]	2.5 ... 8	3 ... 8
Standard nominal flow rate		[l/min]	780	780
Flow rate on manifold rail		[l/min]	730	730
Switching time on/off		[ms]	14/28	13/40

1) Minimum pilot pressure 50% of operating pressure

Technical data – 5/2-way valve, double solenoid

8

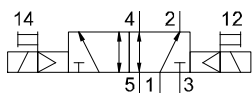

Internal or external pilot air supply

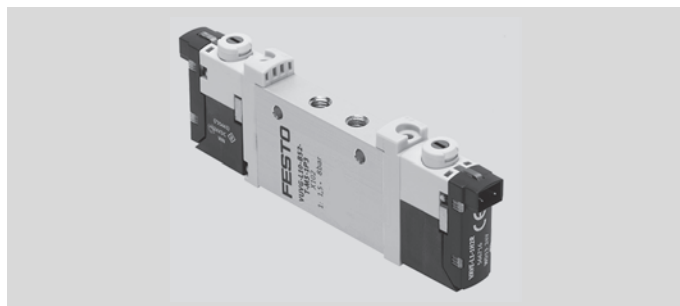

Technical data			Download CAD data → www.festo.com	
Valve function			B52	
Operating pressure	Internal	[bar]	1.5 ... 8	
	External	[bar]	-0.9 ... 10	
Pilot pressure ²⁾		[bar]	1.5 ... 8	
Standard nominal flow rate		[l/min]	780	
Flow rate on manifold rail		[l/min]	730	
Changeover time		[ms]	8	

2) Minimum pilot pressure 50% of operating pressure

Technical data – 5/3-way valve

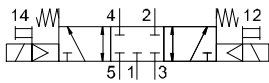

Normally closed (C), internal or external pilot air supply

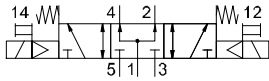

Normally open (U), internal or external pilot air supply

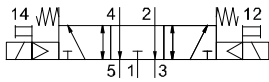

Normally exhausted (E), internal or external pilot air supply

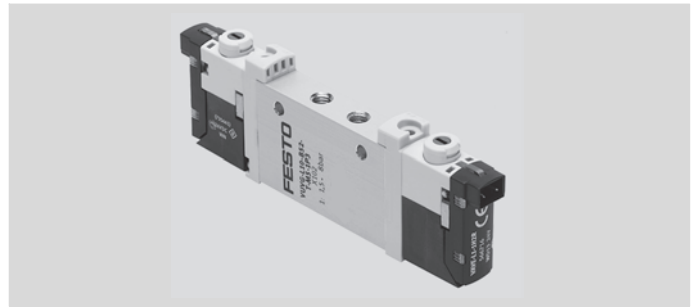

Download CAD data → www.festo.com

Technical data			P53C
Valve function			P53C
Operating pressure	Internal	[bar]	3 ... 8
	External	[bar]	-0.9 ... 10
Pilot pressure ¹⁾		[bar]	3 ... 8
Standard nominal flow rate		[l/min]	600 ... 650
Flow rate on manifold rail		[l/min]	580 ... 620
Switching time on/off		[ms]	12/40
Changeover time		[ms]	20

1) Minimum pilot pressure 50% of operating pressure

Ordering – Product options

Configurable product

This product and all its options can be ordered using the configurator.

The configurator can be found under Products on the DVD or
 → www.festo.com/catalogue/...

Enter the type code in the search field.

★ Quick ordering

Part No.	Type
In-line valve G1/8, 3/2-way valve	
566496	VUVG-L14-T32C-AT-G18-1P3
566505	VUVG-L14-T32C-AZT-G18-1P3
In-line valve G1/8, 5/2-way single solenoid valve	
566499	VUVG-L14-M52-AT-G18-1P3
566508	VUVG-L14-M52-AZT-G18-1P3
574371	VUVG-L14-M52-MT-G18-1P3

Part No.	Type
In-line valve G1/8, 5/2-way double solenoid valve	
566500	VUVG-L14-B52-T-G18-1P3
566509	VUVG-L14-B52-ZT-G18-1P3
In-line valve G1/8, 5/3-way valve	
566501	VUVG-L14-P53C-T-G18-1P3
566510	VUVG-L14-P53C-ZT-G18-1P3

Solenoid valves VUVG-L14 and VUVG-S14, in-line valves G¹/₈

Accessories – Ordering data

Order code – Manifold rails



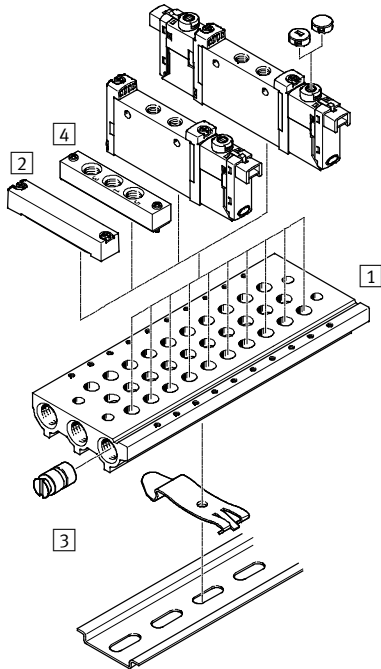

VABM	-	L1	-	14	S	-	G14	-	
Manifold assembly parts									
Manifold rail	VABM								
Valve series	VUVG								
Valve width	14 mm								
Manifold rail with ports 1, 3, 5	For G ¹ / ₈ in-line valves								
									S

Number of valve positions	2 to 10, 12, 14 and 16
Ports 1, 3, 5	G14 G ¹ / ₄

Manifold assembly

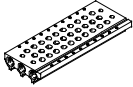

8

		Part No.	Type
1 Manifold rail 	For G ¹ / ₈	★ 566618	VABM-L1-14S-G14-2
		★ 566619	VABM-L1-14S-G14-3
		★ 566620	VABM-L1-14S-G14-4
		★ 566621	VABM-L1-14S-G14-5
		★ 566622	VABM-L1-14S-G14-6
		566623	VABM-L1-14S-G14-7
		★ 566624	VABM-L1-14S-G14-8
		566625	VABM-L1-14S-G14-9
		★ 566626	VABM-L1-14S-G14-10
		★ 566627	VABM-L1-14S-G14-12
		566628	VABM-L1-14S-G14-14
		566629	VABM-L1-14S-G14-16
		2 Blanking plate	
	For G ¹ / ₈	★ 569989	VABB-L1-14
3 Blanking plug			
	Separator for pressure zones	★ 569996	VABD-10-B
4 Supply plate			
	For G ¹ / ₈	★ 569993	VABF-L1-14-P3A4-G18
Seals for in-line valves (10 pieces incl. 20 screws)			
	For G ¹ / ₈	★ 566675	VABD-L1-14X-S-G18

Technical data

Technical data		Download CAD data → www.festo.com											
Valve function		T32-A			T32-M		M52-R	B52	M52-M	P53			
Normal position		C ¹⁾	U ²⁾	H ⁴⁾	C ¹⁾	U ²⁾	H ⁴⁾	–	–	–	C ¹⁾	U ²⁾	E ³⁾
Pneumatic spring reset method		Yes			No		Yes ⁵⁾	–	No	–			
Mechanical spring reset method		No			Yes		Yes ⁵⁾	–	Yes	–			
Connection	1, 3, 5	G1/8 in manifold rail											
	2, 4	M5 or M7 in manifold rail											
	12/14, 82/84	M5 in manifold rail											
Vacuum operation at port 1		No			Only with external pilot air supply								
Design		Piston spool valve											
Type of mounting		On manifold rail											
Electrical connection		Via connecting plate											
Nominal operating voltage	[V DC]	5, 12 and 24 ±10%											
Power	[W]	1, reduced to 0.35 with holding current reduction											
Duty cycle	[%]	100											
Protection class to EN 60529		IP40 (with plug socket)											

- 1) C = Normally closed
 2) U = Normally open
 3) E = Normally exhausted
 4) H=2x 3/2-way valve in one housing with 1x normally closed and 1x normally open
 5) Combined reset method

Operating conditions

Operating medium		Compressed air to ISO 8573-1:2010 [7:4:4]
Note on operating/pilot medium		Lubricated operation possible (in which case lubricated operation will always be required)
Ambient temperature	[°C]	–5 ... +50, –5 ... +60 with holding current reduction
Temperature of medium	[°C]	–5 ... +50, –5 ... +60 with holding current reduction

Materials

Download CAD data → www.festo.com

Housing		Wrought aluminium alloy
Seals		HNBR, NBR

Technical data – 2x3/2-way valve

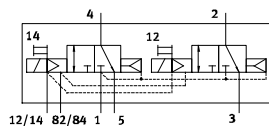

Normally closed,
external pilot air supply⁷⁾

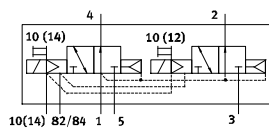

Normally open,
external pilot air supply⁷⁾

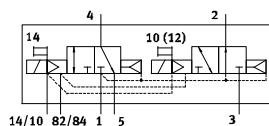

1x normally closed,
1x normally open,
external pilot air supply⁷⁾

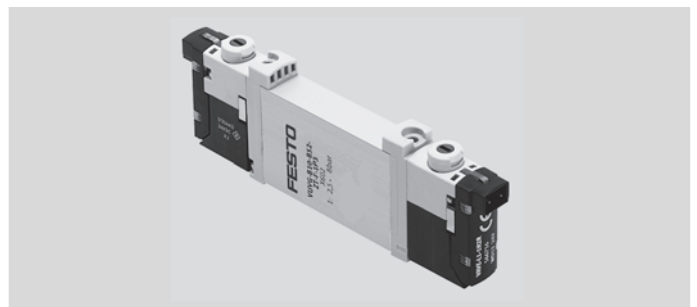

Technical data		Download CAD data → www.festo.com	
Valve function		T32-A	T32-M
Operating pressure	Internal [bar]	1.5 ... 8	3 ... 8
	External [bar]	1.5 ... 10	–0.9 ... 10
Pilot pressure ⁶⁾	[bar]	1.5 ... 8	2 ... 8
Standard nominal flow rate	[l/min]	170	140 ... 150
Flow rate on manifold rail M5	[l/min]	150	120 ... 130
Flow rate on manifold rail M7	[l/min]	160	130 ... 140
Switching time on/off	[ms]	6/16	8/11

- 6) Minimum pilot pressure 50% of operating pressure
 7) Internal pilot air can be selected via sub-base

Solenoid valves VUVG-B10, sub-base valves



Technical data – 5/2-way valve, single solenoid

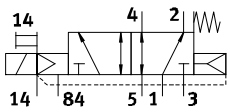

External pilot air supply²⁾

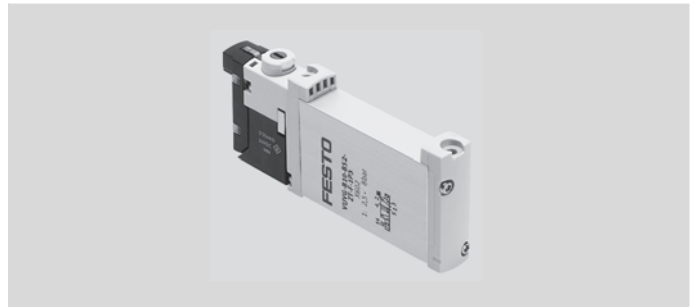

Technical data			Download CAD data → www.festo.com	
Valve function			M52-R	M52-M
Operating pressure	Internal	[bar]	2.5 ... 8	3 ... 8
	External	[bar]	-0.9 ... 10	-0.9 ... 8
Pilot pressure ¹⁾		[bar]	2.5 ... 8	3 ... 8
Standard nominal flow rate		[l/min]	330	285
Flow rate on manifold rail M5		[l/min]	210	180
Flow rate on manifold rail M7		[l/min]	270	230
Switching time on/off		[ms]	7/19	8/24

- 1) Minimum pilot pressure 50% of operating pressure
- 2) Internal pilot air can be selected via sub-base

8

Technical data – 5/2-way valve, double solenoid

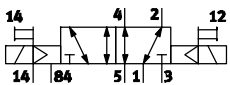

External pilot air supply⁴⁾

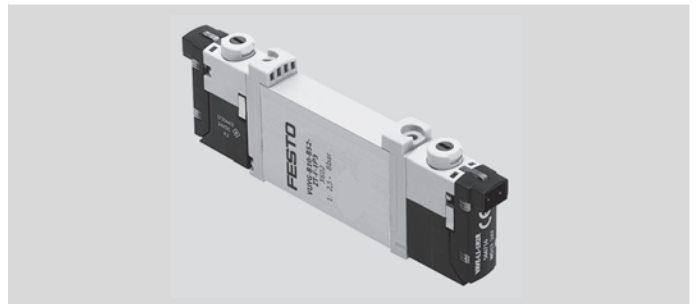

Technical data			Download CAD data → www.festo.com	
Valve function			B52	
Operating pressure	Internal	[bar]	1.5 ... 8	
	External	[bar]	-0.9 ... 10	
Pilot pressure ³⁾		[bar]	1.5 ... 8	
Standard nominal flow rate		[l/min]	330	
Flow rate on manifold rail M5		[l/min]	210	
Flow rate on manifold rail M7		[l/min]	270	
Changeover time		[ms]	7	

- 3) Minimum pilot pressure 50% of operating pressure
- 4) Internal pilot air can be selected via sub-base

Technical data – 5/3-way valve

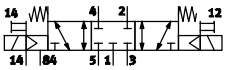

Normally closed,
external pilot air supply²⁾

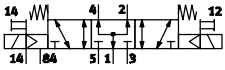

Normally open,
external pilot air supply²⁾

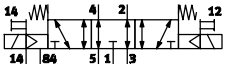

Normally exhausted,
external pilot air supply²⁾

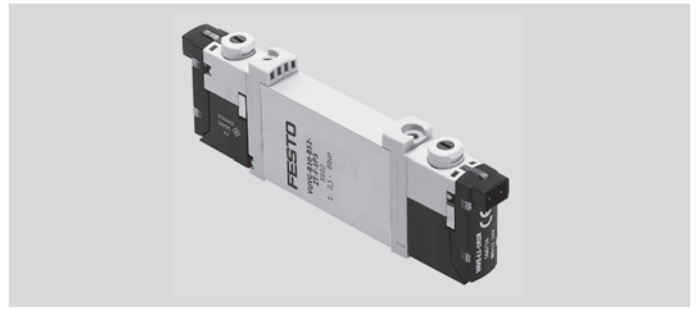











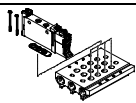
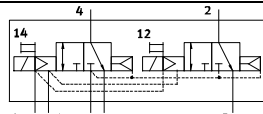
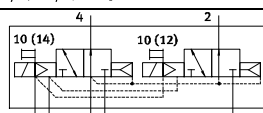
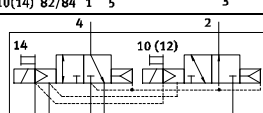
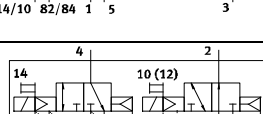
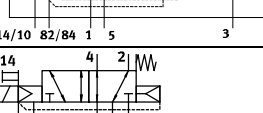
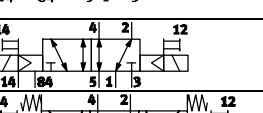

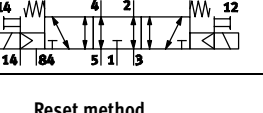
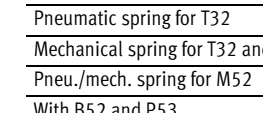
Download CAD data → www.festo.com

Technical data			P53
Valve function			P53
Operating pressure	Internal	[bar]	3 ... 8
	External	[bar]	-0.9 ... 10
Pilot pressure ¹⁾		[bar]	3 ... 8
Standard nominal flow rate		[l/min]	300
Flow rate on manifold rail M5		[l/min]	200
Flow rate on manifold rail M7		[l/min]	250
Switching time on/off		[ms]	10/30
Changeover time		[ms]	16

- 1) Minimum pilot pressure 50% of operating pressure
2) Internal pilot air can be selected via sub-base

Solenoid valves VUVG-B10, sub-base valves

Order code

VUVG	-	B	10	-	-	Z	-	F	-	-	-	-	L	-
Valve design														
 <p>In-line, manifold valve incl. seal and screws</p>														
Width														
10 mm 10														
Valve functions³⁾														
 <p>T32C</p>														
 <p>T32U</p>														
 <p>T32H</p>														
 <p>T32H</p>														
 <p>M52</p>														
 <p>B52</p>														
 <p>P53C</p>														
 <p>P53U</p>														
 <p>P53E</p>														
Reset method														
Pneumatic spring for T32 A														
Mechanical spring for T32 and M52 M														
Pneu./mech. spring for M52 R														
With B52 and P53 -														
Pilot air supply														
External Z														
Manual override														
 Non-detenting H														
 Covered S														
- Non-detenting, detenting T														
Connecting cable														
W1...4 ⁴⁾ Connection pattern H, unsheathed 														
C1...4 ⁴⁾ Connection pattern H, sheathed 														
N1...4 ⁴⁾ M8x1, 3-pin 														
Display														
L LED														
Protective circuit														
- Without holding current reduction (HCR) Power [W] 1														
R ²⁾ With holding current reduction (HCR) 1 to 0.35														
Connecting plate														
H2 Connection pattern H, horizontal plug 														
H3 Connection pattern H, vertical plug 														
L1...4 With 2x flying leads L: 1 = 0.5 m, 2 = 1 m, 3 = 2.5 m, 4 = 5 m 														
R8 Individual plug M8, 3-pin, only without HCR 														
P3 Without connecting plate 														
Nominal operating voltage														
1 24 V DC														
5 12 V DC														
4 5 V DC														
Pneumatic connection														
F In the manifold rail														

8

1) W1/C1 = 0.5 m, W2/C2 = 1 m,
W3/C3 = 2.5 m, W4/C4 = 5 m
2) At 24 V DC

3) Circuit symbol for internal pilot air supply
4) Straight: N1 = 2.5 m, N2 = 5 m
Angled: N3 = 2.5 m, N4 = 5 m

Ordering – Product options

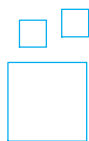

Configurable
product

This product and all its options can
be ordered using the configurator.

The configurator can be found under
Products on the DVD or
→ www.festo.com/catalogue/...

Enter the type code in the search field.

★ Quick ordering

Part No.	Type
Sub-base valve B10, 3/2-way valve	
566487	VUVG-B10-T32C-AZT-F-1P3
574364	VUVG-B10-T32C-MZT-F-1P3
Sub-base valve B10, 5/2-way single solenoid valve	
566490	VUVG-B10-M52-RZT-F-1P3
574367	VUVG-B10-M52-MZT-F-1P3

Part No.	Type
Sub-base valve B10, 5/2-way double solenoid valve	
566491	VUVG-B10-B52-ZT-F-1P3
Sub-base valve B10, 5/3-way valve	
566492	VUVG-B10-P53C-ZT-F-1P3

Solenoid valves VUVG-B10, sub-base valves

Accessories – Ordering data



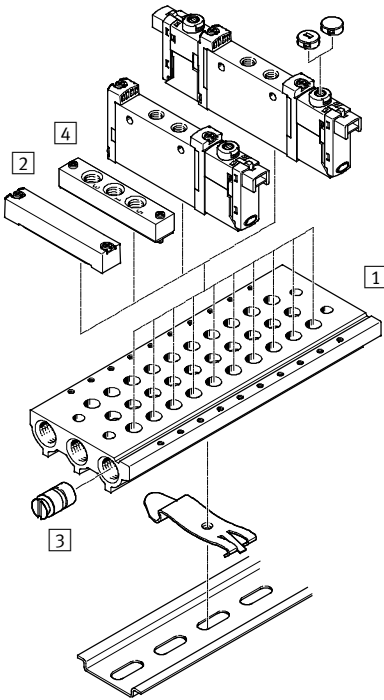

Order code – Manifold rails

VABM	-	L1	-	10	-	G18	-
Manifold assembly parts							
Manifold rail	VABM						
Valve series							
VUVG	L1						
Valve width							
10 mm			10				
Manifold rail with ports 1, 2, 3, 4, 5, 12/14, 82/84							
Port 2 and 4 in M5		W					
Port 2 and 4 in M7		HW					
		Number of valve positions					
		2 to 10, 12, 14 and 16					
		Ports 1, 3, 5					
		G18		G1/8			

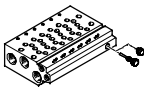
Manifold assembly

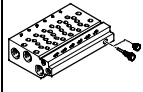

		Part No.	Type
1 Manifold rail 	For 10 W (M5)	566582	VABM-L1-10W-G18-2
		★ 566583	VABM-L1-10W-G18-3
		★ 566584	VABM-L1-10W-G18-4
		566585	VABM-L1-10W-G18-5
		★ 566586	VABM-L1-10W-G18-6
		566587	VABM-L1-10W-G18-7
		★ 566588	VABM-L1-10W-G18-8
		566589	VABM-L1-10W-G18-9
		★ 566590	VABM-L1-10W-G18-10
		★ 566591	VABM-L1-10W-G18-12
		566592	VABM-L1-10W-G18-14
		566593	VABM-L1-10W-G18-16

		Part No.	Type
1 Manifold rail 	For 10 HW (M7)	★ 566606	VABM-L1-10HW-G18-2
		★ 566607	VABM-L1-10HW-G18-3
		★ 566608	VABM-L1-10HW-G18-4
		566609	VABM-L1-10HW-G18-5
		★ 566610	VABM-L1-10HW-G18-6
		566611	VABM-L1-10HW-G18-7
		★ 566612	VABM-L1-10HW-G18-8
		566613	VABM-L1-10HW-G18-9
		566614	VABM-L1-10HW-G18-10
		566615	VABM-L1-10HW-G18-12
		566616	VABM-L1-10HW-G18-14
		566617	VABM-L1-10HW-G18-16
		2 Blanking plate	
	For 10 W/ 10 HW	★ 566495	VABB-L1-10-W
3 Blanking plug			
	Separator for pressure zones	★ 569994	VABD-6-B
4 Supply plate			
	For 10 W	★ 569991	VABF-L1-10-P3A4-M5
	For 10 HW	★ 569992	VABF-L1-10-P3A4-M7
Seals for in-line valves (10 pieces incl. 20 screws)			
	For 10 W/ 10 HW	★ 566674	VABD-L1-10B-S-M7

Technical data

Technical data		Download CAD data → www.festo.com											
Valve function		T32-A			T32-M			M52-A	B52	M52-M	P53		
Normal position		C ¹⁾	U ²⁾	H ⁴⁾	C ¹⁾	U ²⁾	H ⁴⁾	–	–	–	C ¹⁾	U ²⁾	E ³⁾
Pneumatic reset method		Yes			No			Yes	–	No	–		
Mechanical reset method		No			Yes			No	–	Yes	–		
Ports	1, 3, 5	G $\frac{1}{4}$ in manifold rail											
	2, 4	G $\frac{1}{8}$ in manifold rail											
	12/14, 82/84	M5 in manifold rail											
Vacuum operation at port 1		No			Only with external pilot air supply								
Design		Piston spool valve											
Type of mounting		On manifold rail											
Electrical connection		Via connecting plate											
Nominal operating voltage	[V DC]	5, 12 and 24 ±10%											
Power	[W]	1, reduced to 0.35 with holding current reduction											
Duty cycle	[%]	100											
Protection class to EN 60529		IP40 (with plug socket)											

- 1) C = Normally closed
 2) U = Normally open
 3) E = Normally exhausted
 4) H = 2x 3/2-way valve in one housing with 1x normally closed and 1x normally open

Operating conditions

Operating medium		Compressed air to ISO 8573-1:2010 [7:4:4]	
Note on operating/pilot medium		Lubricated operation possible (in which case lubricated operation will always be required)	
Ambient temperature	[°C]	–5 ... +50, –5 ... +60 with holding current reduction	
Temperature of medium	[°C]	–5 ... +50, –5 ... +60 with holding current reduction	

Materials

Download CAD data → www.festo.com

Housing		Wrought aluminium alloy	
Seals		HNBR, NBR	

Technical data – 2x3/2-way valve

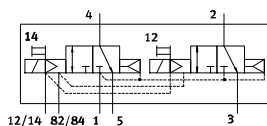

Normally closed (C),
external pilot air supply⁶⁾

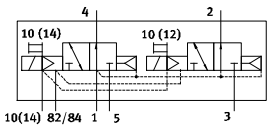

Normally open (U),
external pilot air supply⁶⁾

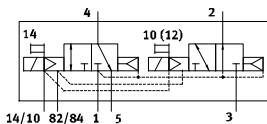

1x normally closed,
1x normally open (H),
external pilot air supply⁶⁾

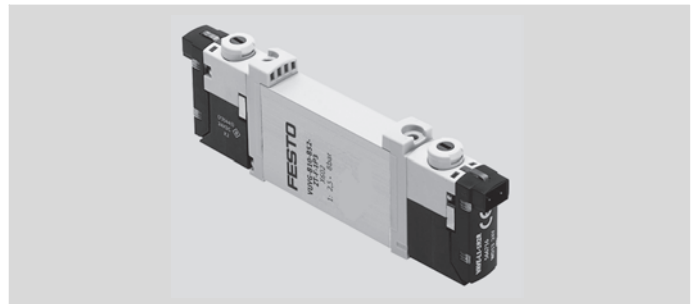

Technical data		Download CAD data → www.festo.com	
Valve function		T32-A	T32-M
Operating pressure	Internal	[bar]	1.5 ... 8
	External	[bar]	–0.9 ... 10
Pilot pressure ⁵⁾		[bar]	1.5 ... 8
Standard nominal flow rate		[l/min]	580 ... 600
Flow rate on manifold rail		[l/min]	410 ... 430
Switching time on/off		[ms]	8/23

- 5) Minimum pilot pressure 50% of operating pressure
 6) Internal pilot air can be selected via sub-base

Solenoid valves VUVG-B14, sub-base valves

Technical data – 5/2-way valve, single solenoid

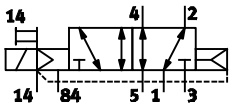

External pilot air supply²⁾

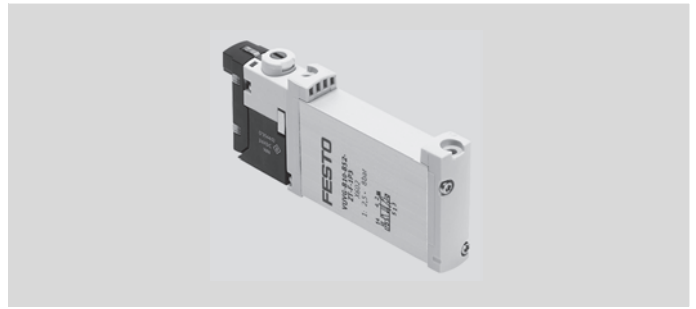

Technical data			Download CAD data → www.festo.com	
Valve function			M52-A	M52-M
Operating pressure	Internal	[bar]	2.5 ... 8	3 ... 8
	External	[bar]	-0.9 ... 10	-0.9 ... 10
Pilot pressure ¹⁾		[bar]	2.5 ... 8	3 ... 8
Standard nominal flow rate		[l/min]	680	680
Flow rate on manifold rail		[l/min]	580	580
Switching time on/off		[ms]	14/28	13/40

- 1) Minimum pilot pressure 50% of operating pressure
- 2) Internal pilot air can be selected via sub-base

8

Technical data – 5/2-way valve, double solenoid

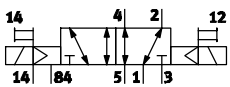

External pilot air supply⁴⁾

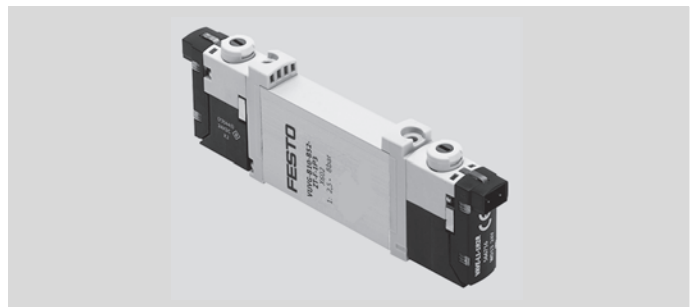

Technical data			Download CAD data → www.festo.com	
Valve function			B52	
Operating pressure	Internal	[bar]	1.5 ... 8	
	External	[bar]	-0.9 ... 10	
Pilot pressure ³⁾		[bar]	1.5 ... 8	
Standard nominal flow rate		[l/min]	680	
Flow rate on manifold rail		[l/min]	580	
Changeover time		[ms]	8	

- 3) Minimum pilot pressure 50% of operating pressure
- 4) Internal pilot air can be selected via sub-base

Technical data – 5/3-way valve

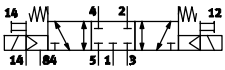

Normally closed (C),
external pilot air supply²⁾

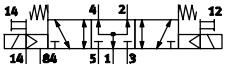

Normally open (U),
external pilot air supply²⁾

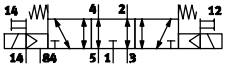

Normally exhausted (E),
external pilot air supply²⁾

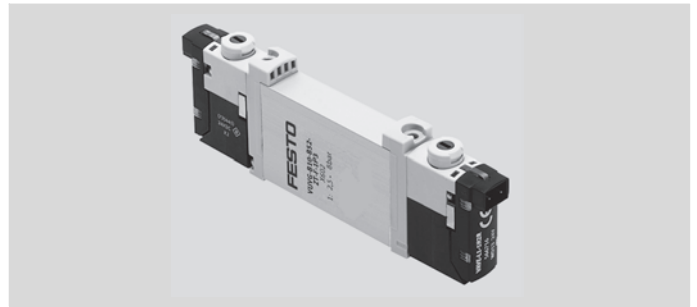











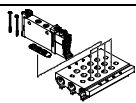
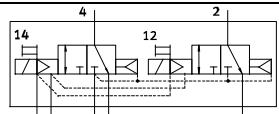
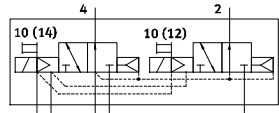
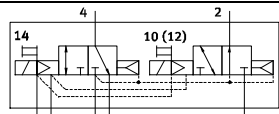
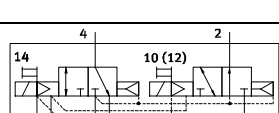
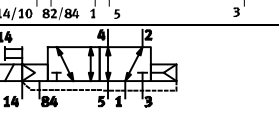
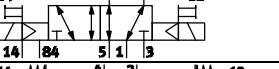
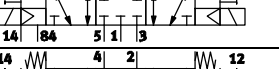

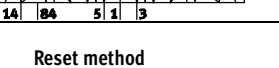

Download CAD data → www.festo.com

Technical data			P53
Valve function			P53
Operating pressure	Internal	[bar]	3 ... 8
	External	[bar]	-0.9 ... 10
Pilot pressure ¹⁾		[bar]	3 ... 8
Standard nominal flow rate		[l/min]	580 ... 600
Flow rate on manifold rail		[l/min]	510 ... 540
Switching time on/off		[ms]	12/40
Changeover time		[ms]	20

- 1) Minimum pilot pressure 50% of operating pressure
 2) Internal pilot air can be selected via sub-base

Solenoid valves VUVG-B14, sub-base valves

Order code

VUVG	-	B	14	-	-	Z	-	F	-	-	-	-	L	-
Valve design														
 <p>In-line, manifold valve incl. seal and screws</p>														
Width														
14 mm 14														
Valve functions³⁾														
 T32C														
 T32U														
 T32H														
 T32H														
 M52														
 B52														
 P53C														
 P53U														
 P53E														
Reset method														
Pneumatic spring for T32 and M52 A														
Mechanical spring for T32 and M52 M														
With B52 and P53 -														
Pilot air supply														
External Z														
Manual override														
 Non-detenting H														
 Covered S														
 Non-detenting, detenting T														
Connecting cable														
W1...4 ⁴⁾ Connection pattern H, unsheathed 														
C1...4 ⁴⁾ Connection pattern H, sheathed 														
N1...4 ⁴⁾ M8x1, 3-pin 														
Display														
L LED														
Protective circuit														
- Without holding current reduction (HCR) Power [W] 1														
R ²⁾ With holding current reduction (HCR) 1 to 0.35														
Connecting plate														
H2 Connection pattern H, horizontal plug 														
H3 Connection pattern H, vertical plug 														
L1...4 With 2x flying leads L: 1 = 0.5 m, 2 = 1 m, 3 = 2.5 m, 4 = 5 m 														
R8 Individual plug M8, 3-pin, only without HCR 														
P3 Without connecting plate 														
Nominal operating voltage														
1 24 V DC														
5 12 V DC														
4 5 V DC														
Pneumatic connection														
F In the manifold rail														

8

1) W1/C1 = 0.5 m, W2/C2 = 1 m,
W3/C3 = 2.5 m, W4/C4 = 5 m
2) At 24 V DC

3) Circuit symbol for internal pilot air supply
4) Straight: N1 = 2.5 m, N2 = 5 m
Angled: N3 = 2.5 m, N4 = 5 m

Ordering – Product options

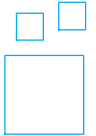

Configurable product

This product and all its options can be ordered using the configurator.

The configurator can be found under Products on the DVD or
 → www.festo.com/catalogue/...

Enter the type code in the search field.

★ Quick delivery

Part No.	Type
Sub-base valve B14, 3/2-way valve	
566513	VUVG-B14-T32C-AZT-F-1P3
566518	VUVG-B14-P53C-ZT-F-1P3
Sub-base valve B14, 5/2-way single solenoid valve	
566516	VUVG-B14-M52-AZT-F-1P3

Part No.	Type
Sub-base valve B14, 5/2-way double solenoid valve	
566517	VUVG-B14-B52-ZT-F-1P3
Sub-base valve B14, 5/3-way valve	
566519	VUVG-B14-P53E-ZT-F-1P3
566520	VUVG-B14-P53U-ZT-F-1P3

Solenoid valves VUVG-B14, sub-base valves

Accessories – Ordering data



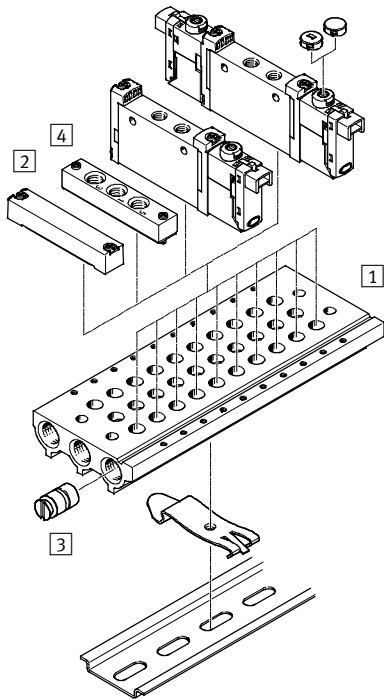

Order code – Manifold rails

VABM	-	L1	-	14	W	-	G14	-
Manifold assembly parts						Number of valve positions		
Manifold rail	VABM					2 to 10, 12, 14 and 16		
Valve series						Port 1, 3, 5		
VUVG	L1					G14 G¼		
Valve width								
14 mm				14				
Manifold rail with port 1, 3, 5								
For G¼ in-line valves						W		

Manifold assembly

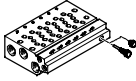

8

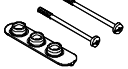
		Part No.	Type
1 Manifold rail			
	For 14 W	★ 566642	VABM-L1-14W-G14-2
		★ 566643	VABM-L1-14W-G14-3
		★ 566644	VABM-L1-14W-G14-4
		★ 566645	VABM-L1-14W-G14-5
		★ 566646	VABM-L1-14W-G14-6
		566647	VABM-L1-14W-G14-7
		★ 566648	VABM-L1-14W-G14-8
		566649	VABM-L1-14W-G14-9
		★ 566650	VABM-L1-14W-G14-10
		★ 566651	VABM-L1-14W-G14-12
		566652	VABM-L1-14W-G14-14
		566653	VABM-L1-14W-G14-16
		2 Blanking plate	
	For 14 W	★ 569989	VABB-L1-14
3 Blanking plug			
	Separator for pressure zones	★ 569996	VABD-10-B
4 Supply plate			
	For 14 W	★ 569993	VABF-L1-14-P3A4-G18
Seals for in-line valves (10 pieces incl. 20 screws)			
	For 14 W	★ 566676	VABD-L1-14B-S-G18

Connecting plates

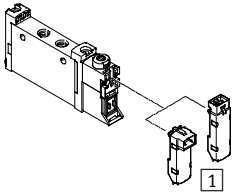

System overview

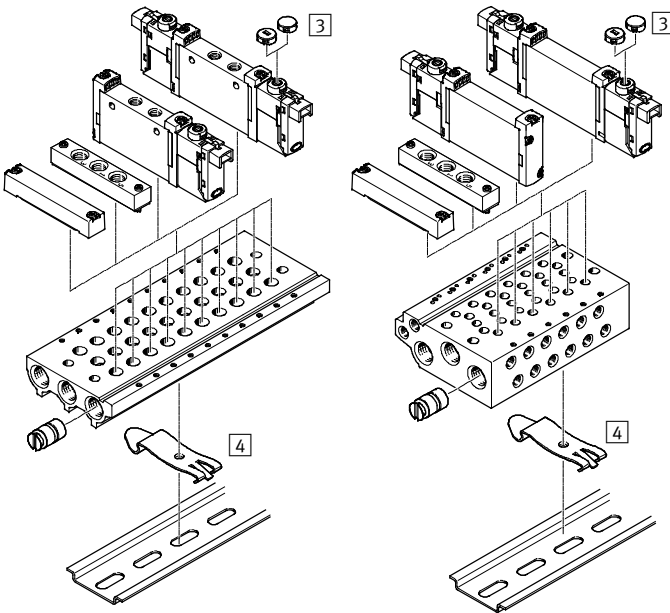

Accessories overview

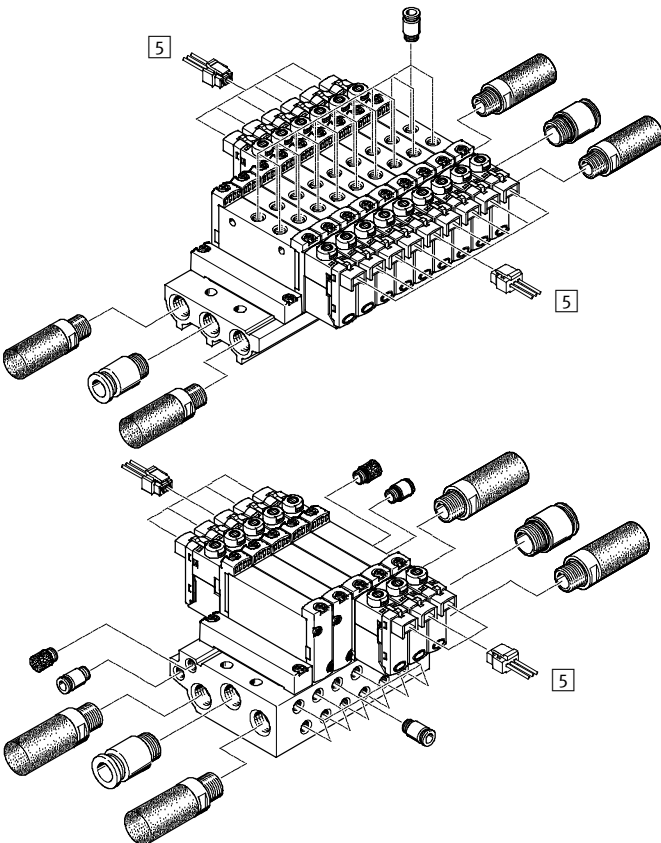

Accessories – Ordering data

		Part No.	Type
1 Connecting plates, connecting plates, H2			
	12/24 V DC	★ 566714	VAVE-L1-1VH2-LP
	24 V DC	★ 566716	VAVE-L1-1H2-LR
Connecting plates, H3			
	12/24 V DC	★ 566715	VAVE-L1-1VH3-LP
	24 V DC	★ 566717	VAVE-L1-1H3-LR
Connecting plates, 1L1 ... 1L4/1VL1 ... 1VL4			
	24 V DC	★ 566726	VAVE-L1-1L1-LR
		★ 566727	VAVE-L1-1L2-LR
		★ 566728	VAVE-L1-1L3-LR
		★ 566729	VAVE-L1-1L4-LR
	12/24 V DC	★ 566722	VAVE-L1-1VL1-LP
		★ 566723	VAVE-L1-1VL2-LP
		★ 566724	VAVE-L1-1VL3-LP
		★ 566725	VAVE-L1-1VL4-LP
Connecting plates, R8/R1			
	12/24 V DC	573919	VAVE-L1-1VR8-LP
	24 V DC	573920	VAVE-L1-1R8-LR
3 Covers for manual override			
	Covered	540898	VMPA-HBV-B
	Non-detenting	540897	VMPA-HBT-B
4 H-rail mounting			
	2 pieces	★ 569998	VAME-T-M4
5 Plug socket with cable, open end			
	0.5 m	★ 566654	NEBV-H1G2-KN-0.5-LE2
	1 m	★ 566655	NEBV-H1G2-KN-1-LE2
	2.5 m	★ 566656	NEBV-H1G2-KN-2.5-LE2
	5 m	★ 566657	NEBV-H1G2-KN-5-LE2
	0.5 m	★ 566658	NEBV-H1G2-P-0.5-N-LE2
	1 m	★ 566659	NEBV-H1G2-P-1-N-LE2
	2.5 m	★ 566660	NEBV-H1G2-P-2.5-N-LE2
	5 m	★ 566661	NEBV-H1G2-P-5-N-LE2
Inscription label holder			
	10 pieces	★ 570818	ASLR-D-L1

Solenoid/pneumatic valves, Tiger Classic

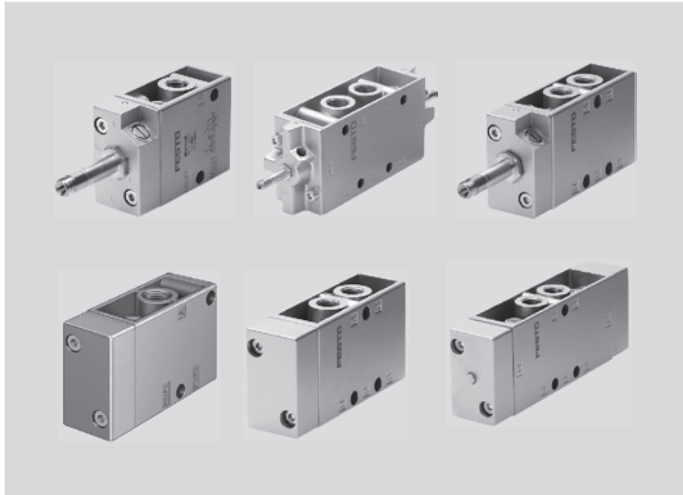

- Electrically or pneumatically actuated valves
- Internal or external pilot air supply
- Sturdy and reliable
- ★ Quick ordering of basic designs → 600, 603

→ www.festo.com/catalogue/tiger classic

Product range overview

Type	Pneumatic connection	Valve function	Operating voltage [V DC]	[V AC]	Normal position	Pilot air supply		→ Page/online
Solenoid valve								
MOFH	G1/8	3/2-way valve	12, 24, 42, 48	24, 42, 48, 110, 230, 240	Closed	Internal	External	597
	G1/4							598
	G1/2							598
	G3/4							599
MFH	G1/8	3/2-way valve	12, 24, 42, 48	24, 42, 48, 110, 230, 240	Open	Internal	-	597
	G1/4							598
	G1/2							598
	G3/4							599
MFH	G1/8	5/2-way valve	12, 24, 42, 48	24, 42, 48, 110, 230, 240	-	Internal	External	597
	G1/4							598
	G1/2							598
Double solenoid valve								
JMFH	G1/8	5/2-way valve	12, 24, 42, 48	24, 42, 48, 110, 230, 240	-	Internal	External	597
	G1/4							598
	G1/2							598
Double solenoid valve with dominant signal								
JMFDH	G1/8	5/2-way valve	12, 24, 42, 48	24, 42, 48, 110, 230, 240	-	-	External	597
	G1/4							598
Pneumatic valve								
VL/O	G1/8	3/2-way valve	-	-	Optionally open or closed	-	-	601
	G1/4							601
	G1/2							602
	G3/4							602
VL	G1/8	5/2-way valve	-	-	-	-	-	601
	G1/4							601
	G1/2							602
Pneumatic double pilot valve								
JH	G1/8	5/2-way valve	-	-	-	-	-	601
	G1/4							601
	G1/2							602
Pneumatic double pilot valve with dominant signal								
JDH	G1/8	5/2-way valve	-	-	-	-	-	601
	G1/4							601

Solenoid valves MFH/MOFH/JMFH/JMFDH, Tiger Classic

Technical data

Technical data		Download CAD data → www.festo.com		
Valve function		3/2-way, single solenoid	5/2-way, single solenoid	5/2-way, double solenoid
Actuation type		Electric		
Reset method		Mechanical spring		–
Type of control		Piloted		
Pilot air supply		Internal or external		
Direction of flow		Non-reversible		

Operating conditions	
Operating medium	Compressed air to ISO 8573-1:2010 [7:4:4]
Note on operating/pilot medium	Lubricated operation possible (in which case lubricated operation will always be required)
Ambient temperature	[°C] –5 ... +40
Temperature of medium	[°C] –10 ... +60

Materials	
Housing	Die cast aluminium
Seals	NBR

Technical data – Pneumatic connection G1/8

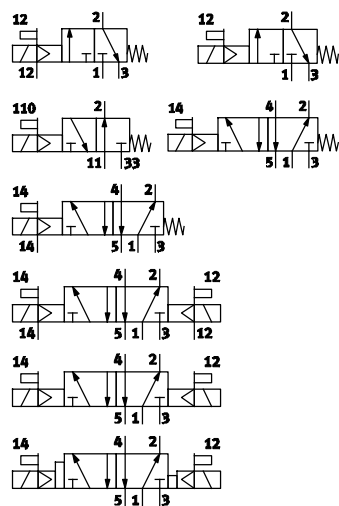

Internal or external pilot air supply

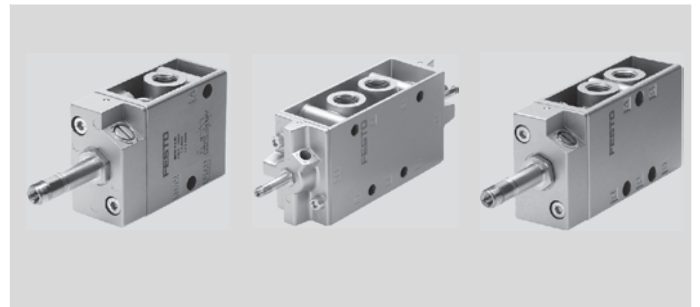

Technical data		Download CAD data → www.festo.com		
Valve function		3/2-way, single solenoid	5/2-way, single solenoid	5/2-way, double solenoid
Nominal size	[mm]	5		
Standard nominal flow rate	[l/min]	500		600
Operating pressure	Internal	[bar] 1.5 ... 8	1.8 ... 8	1.5 ... 8
	External	[bar] –0.95 ... +10	0 ... 10	0 ... 8
	With dominant signal	[bar] –	–	2.5 ... 8
Pilot pressure	[bar]	1 ... 8		1.2 ... 8

Solenoid valves MFH/MOFH/JMFH/JMFDH, Tiger Classic

Technical data – Pneumatic connection G1/4

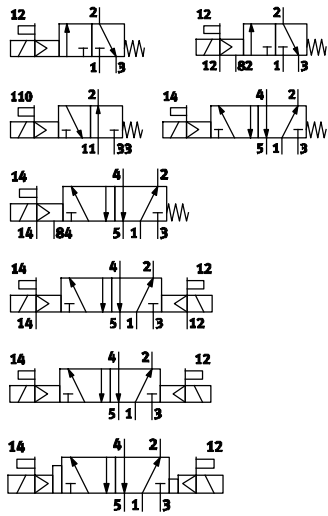

Internal or external pilot air supply

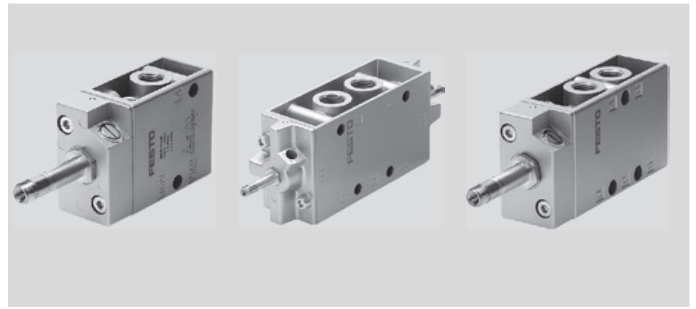

Technical data		Download CAD data → www.festo.com		
Valve function		3/2-way, single solenoid	5/2-way, single solenoid	5/2-way, double solenoid
Nominal size	[mm]	7		
Standard nominal flow rate	[l/min]	800	1,000	1,100
Operating pressure	Internal	[bar] 1.5 ... 8	2.2 ... 8	1.5 ... 8
	External	[bar] -0.95 ... +10	0 ... 8	0 ... 8
	With dominant signal	[bar] -	-	2.5 ... 8
Pilot pressure	[bar]	1 ... 8	1.5 ... 8	1.2 ... 8

Technical data – Pneumatic connection G1/2

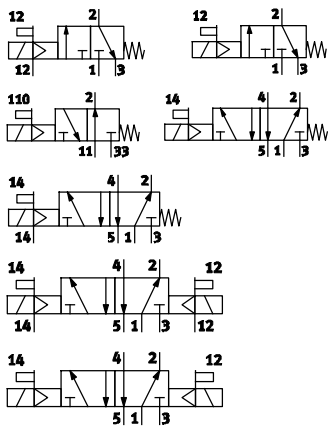

Internal or external pilot air supply

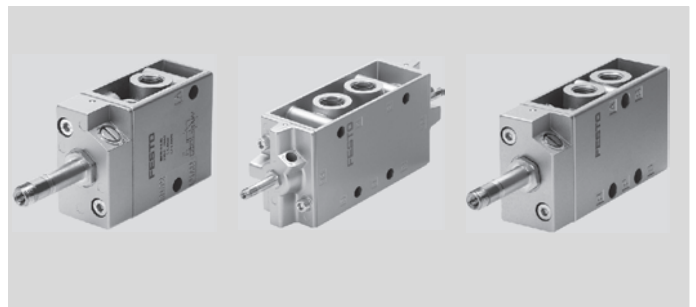

Technical data		Download CAD data → www.festo.com		
Valve function		3/2-way, single solenoid	5/2-way, single solenoid	5/2-way, double solenoid
Nominal size	[mm]	14		
Standard nominal flow rate	[l/min]	3,700	3,700	4,500
Operating pressure	Internal	[bar] 1.5 ... 8	2 ... 8	2 ... 8
	External	[bar] -0.95 ... +10	0 ... 8	0 ... 8
	Pilot pressure	[bar]	1 ... 8	1.5 ... 8

Technical data – Pneumatic connection G3/4

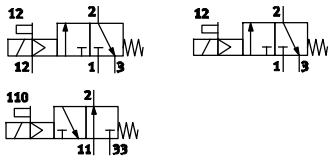

Internal or external pilot air supply

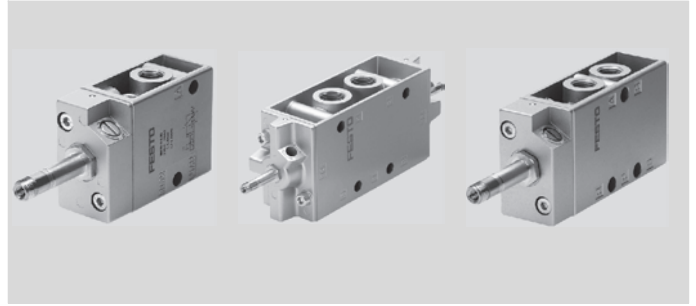

Technical data

Download CAD data → www.festo.com

Valve function		3/2-way, single solenoid
Nominal size	[mm]	19
Standard nominal flow rate	[l/min]	7,500
Operating pressure	Internal	[bar] 2 ... 8
	External	[bar] -0.95 ... +10
Pilot pressure	[bar]	1 ... 8

Solenoid valves MFH/MOFH/JMFH/JMFDH, Tiger Classic

Order code

Type	
MFH	Single solenoid, for F solenoid coil, normally closed
MOFH	Single solenoid, for F solenoid coil, normally open
JMFH	Double solenoid, for F solenoid coil
JMFDH	Double solenoid, for F solenoid coil, with dominant signal 1
Valve function	
3	3/2-way valve
5	5/2-way valve
Pneumatic connections	
1/8	G1/8
1/4	G1/4
1/2	G1/2
3/4	G3/4 2
Pilot air supply	
	Internal
S	External

8

- 1 Only with pneumatic connection G1/8 or G1/4
- 2 Only in combination with 3/2-way valve

Ordering – Product options

Configurable product

This product and all its options can be ordered using the configurator.

The configurator can be found under Products on the DVD or
[→ www.festo.com/catalogue/...](http://www.festo.com/catalogue/...)

Enter the type code in the search field.

★ Quick ordering

Part No.	Type
3/2-way solenoid valve, internal pilot air	
9964	MFH-3-1/4
7802	MFH-3-1/8
7876	MOFH-3-1/4
7877	MOFH-3-1/8
3/2-way solenoid valve, external pilot air	
7959	MFH-3-1/4-S
7958	MFH-3-1/8-S

Part No.	Type
5/2-way solenoid valve, internal pilot air	
6211	MFH-5-1/4
9982	MFH-5-1/8
5/2-way solenoid valve, external pilot air	
10349	MFH-5-1/4-S
10348	MFH-5-1/8-S

Part No.	Type
5/2-way double solenoid valve, internal pilot air	
8820	JMFH-5-1/8
10410	JMFH-5-1/4
5/2-way double solenoid valve, external pilot air	
14008	JMFH-5-1/8-S
14009	JMFH-5-1/4-S
5/2-way double solenoid valve, with dominant signal	
8821	JMFDH-5-1/8
10411	JMFDH-5-1/4

600

→ www.festo.com/catalogue/...

Subject to change – 2013/11

Technical data

Technical data		Download CAD data → www.festo.com		
Valve function		3/2-way, single pilot	5/2-way, single pilot	5/2-way, double pilot
Actuation type	Pneumatic			
Reset method	Mechanical spring			–
Type of control	Direct			
Direction of flow	Reversible	Non-reversible		

Operating conditions

Operating medium	Compressed air to ISO 8573-1:2010 [7:4:4]			
Note on operating/pilot medium	Lubricated operation possible (in which case lubricated operation will always be required)			
Ambient temperature	[°C]	–10 ... +60		

Materials

Housing	Die cast aluminium			
Seals	NBR			

Technical data – Pneumatic connection G1/8

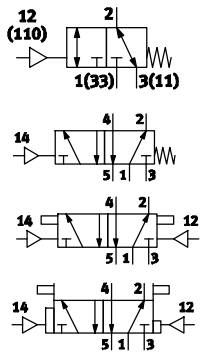

Technical data		Download CAD data → www.festo.com		
Valve function		3/2-way, single pilot	5/2-way, single pilot	5/2-way, double pilot
Nominal size	[mm]	5		
Standard nominal flow rate	[l/min]	500		600
Operating pressure	[bar]	–0.95 ... +10 (normally closed) 0 ... 10 (normally open)	0 ... 10	0 ... 10
Pilot pressure	[bar]	Max. 10		

Technical data – Pneumatic connection G1/4

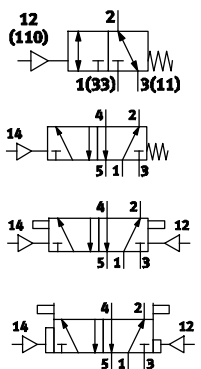

Technical data		Download CAD data → www.festo.com		
Valve function		3/2-way, single pilot	5/2-way, single pilot	5/2-way, double pilot
Nominal size	[mm]	7		

Pneumatic valves VL/O, VL, JH, JDH, Tiger Classic

Technical data – Pneumatic connection G1/4

Technical data		Download CAD data → www.festo.com		
Valve function		3/2-way, single pilot	5/2-way, single pilot	5/2-way, double pilot
Standard nominal flow rate	[l/min]	800	800	1,100
Operating pressure	[bar]	-0.95 ... +10 (normally closed) 0 ... 10 (normally open)	0 ... 8	0 ... 8
Pilot pressure	[bar]	Max. 10		

Technical data – Pneumatic connection G1/2

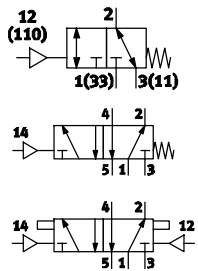

Technical data		Download CAD data → www.festo.com		
Valve function		3/2-way, single pilot	5/2-way, single pilot	5/2-way, double pilot
Nominal size	[mm]	14		
Standard nominal flow rate	[l/min]	3,700	3,700	4,500
Operating pressure	[bar]	-0.95 ... +10 (normally closed) 0 ... 10 (normally open)	0 ... 10	0 ... 10
Pilot pressure	[bar]	Max. 10		

Technical data – Pneumatic connection G3/4

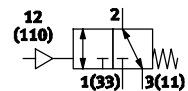

Technical data		Download CAD data → www.festo.com		
Valve function		3/2-way, single pilot		
Nominal size	[mm]	19		
Standard nominal flow rate	[l/min]	7,500		
Operating pressure	[bar]	-0.95 ... +10 (normally closed) 0 ... 10 (normally open)		
Pilot pressure	[bar]	Max. 10		

Order code

VL/O			
Type			
VL/O	Single pilot, normally open or closed		
VL	Single pilot		
JH	Double pilot		
JDH	Double pilot, with dominant signal		<input type="checkbox"/>
Valve function			
3	3/2-way valve		
5	5/2-way valve		
Pneumatic connection			
1/8	G1/8		
1/4	G1/4		
1/2	G1/2		
3/4	G3/4		<input type="checkbox"/>

Only with pneumatic connection G1/8 or G1/4

Only in combination with 3/2-way valve

Ordering – Product options

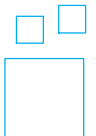

Configurable product

This product and all its options can be ordered using the configurator.

The configurator can be found under Products on the DVD or
[→ www.festo.com/catalogue/...](http://www.festo.com/catalogue/...)

Enter the type code in the search field.

★ Quick ordering

Part No.	Type
3/2-way pneumatic valve	
7803	VL/O-3-1/8-B
9984	VL/O-3-1/4
5/2-way pneumatic valve	
9764	VL-5-1/8
9199	VL-5-1/4

Part No.	Type
5/2-way double pilot valve	
8823	JH-5-1/8
10408	JH-5-1/4
5/2-way double pilot valve with dominant signal	
8824	JDH-5-1/8
10409	JDH-5-1/4

Solenoid valves MFH/MOFH/JMFH/JMFDH, Tiger Classic

Accessories

Mounting on manifold block

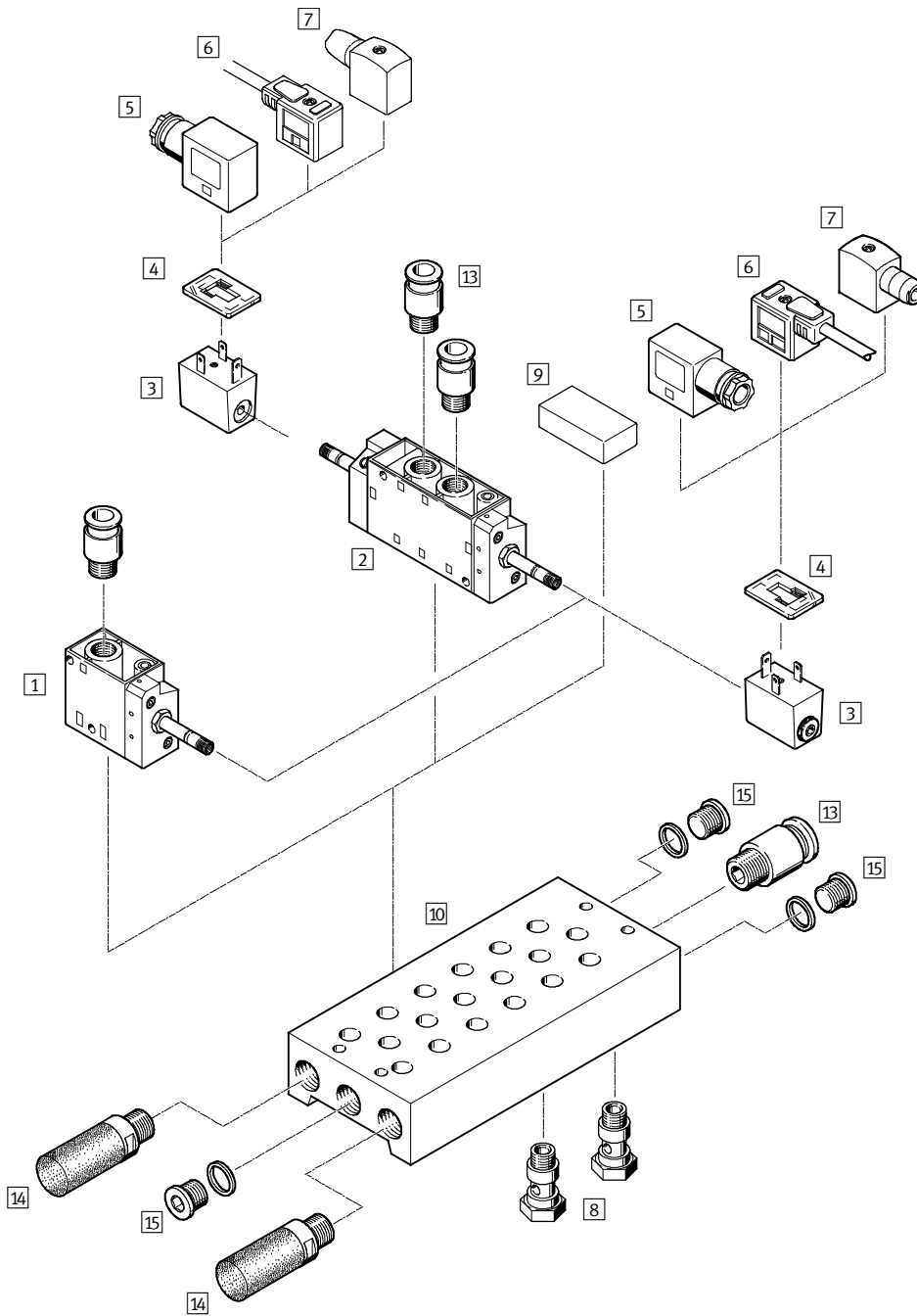

		→ Page/online
1	Solenoid valve MFH	600
2	Solenoid valve JMFH	600
3	F solenoid coil MSFG, MSFW	607
4	Illuminating seal M...LD	607
5	Plug socket MSSD-F-S	607
6	Plug socket with cable KMF	607
7	Plug socket MSSD-F	607
8	Hollow bolt VT	607
9	Blanking plate PRSB	607
10	Manifold block PRS	607
13	Push-in fitting QS	qs
14	Silencer U	u
15	Blanking plug B (3 included in the scope of delivery of the manifold block PRS)	b-1

Accessories

Mounting on manifold rail

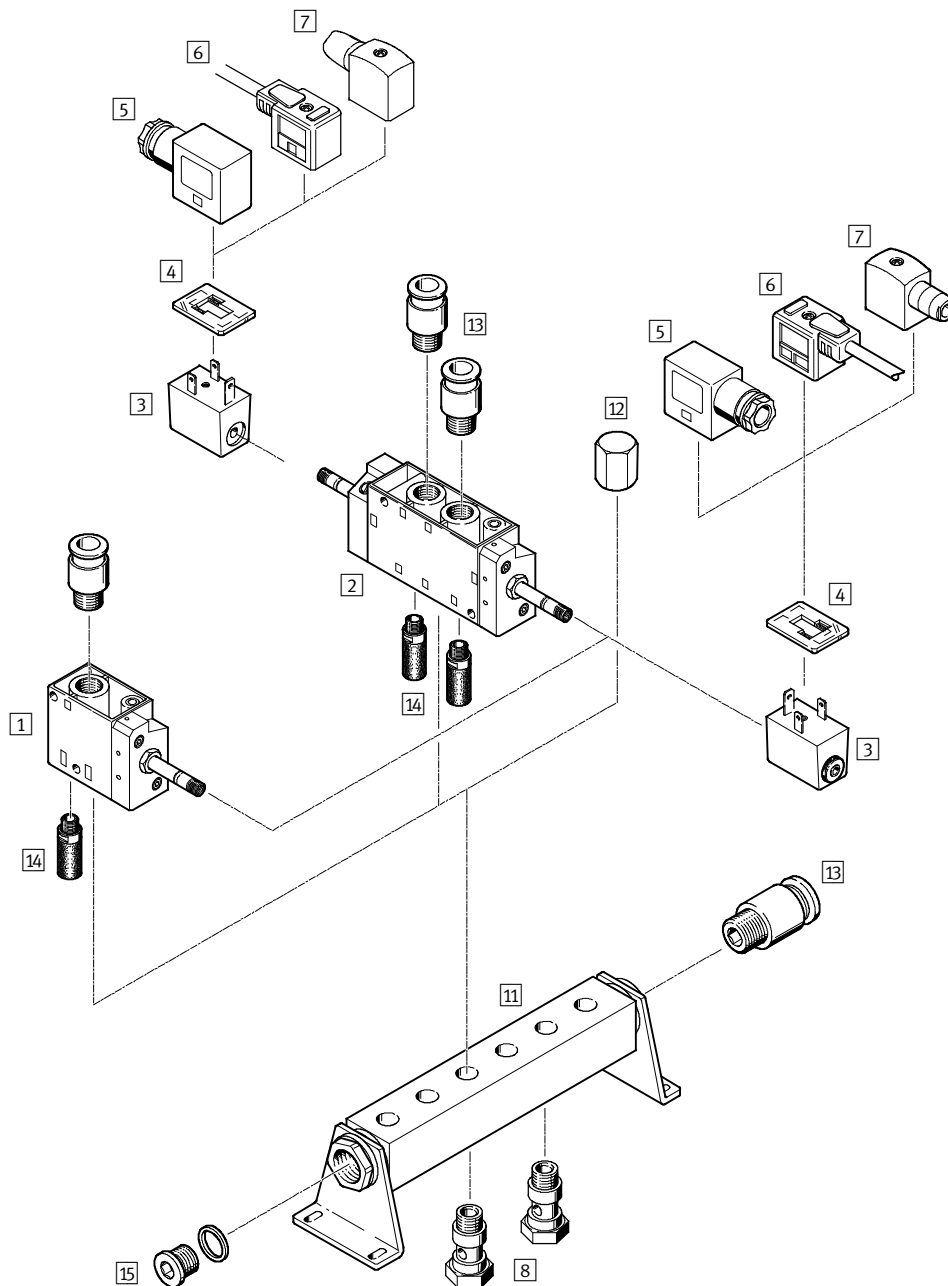

		→ Page/online
1	Solenoid valve JMFH	600
2	Solenoid valve MFH	600
3	F solenoid coil MSFG, MSFW	607
4	Illuminating seal M...-LD	607
5	Plug socket MSSD-F-S	607
6	Plug socket with cable KMF	607
7	Plug socket MSSD-F	607
8	Hollow bolt VT	607
11	Manifold rail PAL	607
12	Cap nut VTM	607
13	Push-in fitting QS	qs
14	Silencer U	u
15	Blanking plug B (1 included in the scope of delivery of the manifold rail PAL)	b-1

Pneumatic valves VL/O, VL, JH, JDH, Tiger Classic

Accessories

Mounting on manifold block

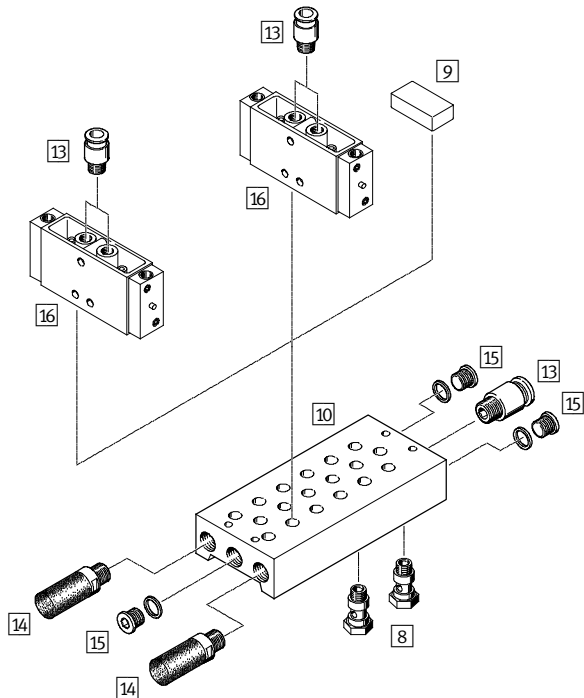



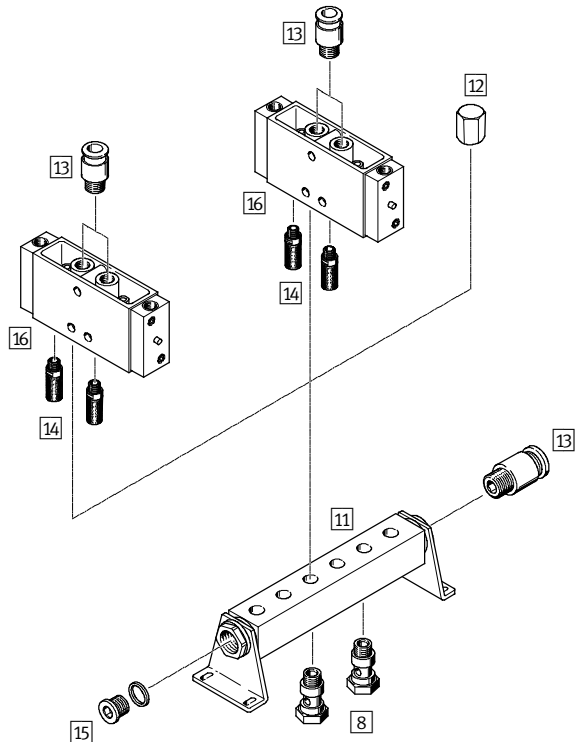

Mounting on manifold rail



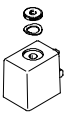

8

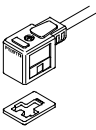
		→ Page/online
8	Hollow bolt VT	607
9	Blanking plate PRSB	607
10	Manifold block PRS	607
11	Manifold rail PAL	607
12	Cap nut VTM	607
13	Push-in fitting QS	qs
14	Silencer	u
15	Blanking plug B	3 included in the scope of delivery of the manifold block PRS 1 included in the scope of delivery of the manifold rail PAL
16	Pneumatic valve VL, JH	603

Accessories – Ordering data

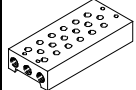
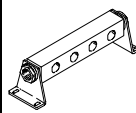
		Part No.	Type
3 F solenoid coil			
	12 V DC	34410	MSFG-12-OD
	24 V DC	★ 34411	MSFG-24/42-50/60-OD
	42 V AC		
	42 V DC	34413	MSFG-42-OD
	24 V AC	34415	MSFW-24-50/60-OD
	48 V AC	34418	MSFW-48-50/60-OD
	110 V AC	34420	MSFW-110-50/60-OD
	120 V AC		
	230 V AC	34422	MSFW-230-50/60-OD
	240 V AC		
	240 V AC	34424	MSFW-240-50/60-OD
	24 V DC	★ 4527	MSFG-24/42-50/60
42 V AC	★ 34412	MSFG-24/42-50/60-DS-OD	
4 Illuminating seal for F solenoid coil			
	-	19143	MF-LD-12-24DC
	-	19144	MF-LD-230AC
5 Plug socket for F solenoid coil, without cable			
	-	★ 34431	MSSD-F
	-	539710	MSSD-F-M16
6 Connecting cable for F solenoid coil			
	24 V DC	30935	KMF-1-24DC-2,5-LED
		30937	KMF-1-24DC-5-LED
		193458	KMF-1-24DC-10-LED
	Up to 240 V	30936	KMF-1-230AC-2,5
		30938	KMF-1-230AC-5
7 Plug socket without cable with insulation displacement technology			
	-	192746	MSSD-F-5-M16
8 Hollow bolt			
	For manifold block PRS		
	G ¹ / ₈	11539	VT- ¹ / ₈ -PRSK
	G ¹ / ₄	9499	VT- ¹ / ₄ -PRS
	For manifold rail PAL		
	G ¹ / ₈	8626	VT- ¹ / ₈
	G ¹ / ₄	206147	VT- ¹ / ₄ -2
G ¹ / ₂	9986	VT- ¹ / ₂	

		Part No.	Type	
9 Blanking plate				
	G ¹ / ₈	11687	PRSB- ¹ / ₈	
	G ¹ / ₄	11688	PRSB- ¹ / ₄	
10 Manifold block				
	Pneumatic connection G ¹ / ₈	11898	PRS- ¹ / ₈ -2	
		11899	PRS- ¹ / ₈ -3	
		11900	PRS- ¹ / ₈ -4	
		11901	PRS- ¹ / ₈ -5	
		11902	PRS- ¹ / ₈ -6	
		Pneumatic connection G ¹ / ₄	10185	PRS- ¹ / ₄ -2
	10186		PRS- ¹ / ₄ -3	
	10187		PRS- ¹ / ₄ -4	
	10188		PRS- ¹ / ₄ -5	
	10189		PRS- ¹ / ₄ -6	
	11 Manifold rail			
		Pneumatic connection G ¹ / ₈	8601	PAL- ¹ / ₈ -2
8602			PAL- ¹ / ₈ -3	
8603			PAL- ¹ / ₈ -4	
8604			PAL- ¹ / ₈ -5	
9767			PAL- ¹ / ₈ -6	
Pneumatic connection G ¹ / ₄			9188	PAL-5- ¹ / ₄ -2
		9189	PAL-5- ¹ / ₄ -3	
		9190	PAL-5- ¹ / ₄ -4	
		9191	PAL-5- ¹ / ₄ -5	
9192		PAL-5- ¹ / ₄ -6		
12 Cap nut				
	G ¹ / ₈	9768	VTM- ¹ / ₈	
	G ¹ / ₄	3099	VTM- ¹ / ₄	
	G ¹ / ₂	9987	VTM- ¹ / ₂	

Non-return valves HGL



- Piloted non-return function
- With push-in connector at one end for tubing O.D. from 4 ... 12 mm
- With connecting thread at one or both ends from M5 ... G1/2
- ★ Quick ordering of basic designs → 608

→ www.festo.com/catalogue/hgl

Technical data

Operating conditions		M5	G1/8	G1/4	G3/8	G1/2
Pneumatic connection 2						
Operating/pilot medium		Compressed air to ISO 8573-1:2010 [7:4:4]				
Note on operating/pilot medium		Lubricated operation possible (in which case lubricated operation will always be required)				
Operating pressure	[bar]	0.5 ... 10				
Pilot pressure	[bar]	2 ... 10			1 ... 10	
Ambient temperature	[°C]	-10 ... +60				

Materials		HGL-...-B with threaded connector at both ends	HGL-...-QS with push-in/threaded connector
Type			
Housing		Anodised wrought aluminium alloy	
Swivel connection		Die-cast zinc	
Releasing ring		-	POM
Non-return collar		NBR	
Seals		NBR	

★ Quick ordering

	Pneumatic connection		Pilot air connection	Standard nominal flow rate qnN in flow direction at 6 bar → 5 bar [l/min]	Standard flow rate qn in flow direction at 6 bar → 0 bar [l/min]		Part No.	Type
	2	1						
Threaded connector at both ends								
	M5	M5	M5	130	200	★	530029	HGL-M5-B
	G1/8	G1/8	M5	300	430	★	530030	HGL-1/8-B
		G1/8	G1/8	300	430		543253	HGL-1/8-1/8-B
	G1/4	G1/4	G1/8	550	680	★	530031	HGL-1/4-B
	G3/8	G3/8	G1/4	1,100	1,500	★	530032	HGL-3/8-B
	G1/2	G1/2	G3/8	1,600	2,100	★	530033	HGL-1/2-B
Push-in/threaded connector								
	M5	QS-4	QS-4	130	200	★	530038	HGL-M5-QS-4
	G1/8	QS-4	M5	200	300	★	530039	HGL-1/8-QS-4
		QS-6	M5	270	400	★	530040	HGL-1/8-QS-6
	G1/4	QS-8	G1/8	390	640	★	530041	HGL-1/4-QS-8
		QS-10	G1/8	400	670	★	530042	HGL-1/4-QS-10
	G3/8	QS-8	G1/4	830	1,200	★	530043	HGL-3/8-QS-8
		QS-10	G1/4	890	1,300	★	530044	HGL-3/8-QS-10
	G1/2	QS-12	G3/8	1,400	2,100	★	530045	HGL-1/2-QS-12



- Flow control valves, flow control at one end
- Exhaust or supply air flow control
- Function combinations consisting of a one-way flow control valve and piloted non-return valve
- With screw-in thread M3 ... G1/2 and push-in connector QS-3 ... QS-12 mm
- Metal and polymer versions
- Can be swivelled 360° around the screw-in axis after mounting
- ★ Quick ordering of basic designs → 612

→ www.festo.com/catalogue/grla

Product range overview

	Valve function	Type	Connection direction	Pneumatic connection 1	Pneumatic connection 2	qnN ¹⁾ [l/min]	Adjusting element	→ Page/online		
Standard										
Metal	Exhaust air one-way flow control function	GRLA	Elbow outlet	QS-3, QS-4, QS-6, QS-8, QS-10, QS-12	M5, G1/8, G1/4, G3/8, G1/2	100 ... 1,580	Slotted head screw	611		
							Knurled screw			
						M5, G1/8, G1/4, G3/8, G1/2, G3/4	M5, G1/8, G1/4, G3/8, G1/2, G3/4	95 ... 4,320	Slotted head screw	grla
						M5, G1/8, G1/4	M5, G1/8, G1/4	95 ... 610	Knurled screw	
			PK-3, PK-4, PK-6	M5, G1/8, G1/4	83 ... 540	Slotted head screw	grla			
		GRLSA	Elbow outlet	QS-6, QS-8	G1/8, G1/4	0 ... 450	Rotary knob with scale, internal hex	grlsa		
	Supply air one-way flow control function	GRLZ	Elbow outlet	QS-3, QS-4, QS-6, QS-8	M5, G1/8	100 ... 215	Slotted head screw	611		
							Slotted head screw			
					PK-3, PK-4, PK-6	M5, G1/8, G1/4	83 ... 540	Slotted head screw	grlz	
		VFOC	Elbow outlet	QS-4, QS-6	Push-in sleeve ²⁾ QS-4, QS-6	100 ... 270	Slotted head screw	vfoc		
Chrome-plated metal	Exhaust air one-way flow control function	GRLA-F	Elbow outlet	QS-4, QS-6, QS-8	G1/8, G1/4	180 ... 530	Slotted head screw	grla		
Polymer	Exhaust air one-way flow control function	GRLA	Elbow outlet	QS-6, QS-8	G1/8, G1/4, G3/8	520 ... 650	Knurled screw	grla		
Flat										
Polymer	Exhaust air one-way flow control function	VFOF	Elbow outlet	QS-6, QS-8	G1/8, G1/4	250 ... 650	Internal hex	613		

1) Standard nominal flow rate in flow control direction at 6 bar → 5 bar.

2) Only suitable for push-in connector QS.

One-way flow control valves

Product range overview

Type	Valve function	Type	Connection direction	Pneumatic connection 1	Pneumatic connection 2	qnN ¹⁾ [l/min]	Adjusting element	→ Page/online
Mini								
Metal	Exhaust air one-way flow control function	GRLA	Elbow outlet	QS-3, QS-4	M3, M5	40 ... 41	Slotted head screw	grla
				M3	M3	0 ... 18	Slotted head screw	grla
		GRGA	Parallel outlet	QS-3	M3	0 ... 41	Slotted head screw	grga
	Supply air one-way flow control function	GRLZ	Elbow outlet	QS-3, QS-4	M3, M5	41 ... 48	Slotted head screw	grlz
				M3	M3	0 ... 18	Slotted head screw	grlz
		GRGZ	Parallel outlet	QS-3	M3	0 ... 41	Slotted head screw	grgz
In-line installation								
Polymer	One-way flow control function	GR	Straight	QS-3, QS-4, QS-6, QS-8	QS-3, QS-4, QS-6, QS-8	25 ... 225	Knurled screw	gr
Metal		GR/GRA		M3, M5, G ¹ / ₈ , G ¹ / ₄ , G ³ / ₈ , G ¹ / ₂ , G ³ / ₄	M3, M5, G ¹ / ₈ , G ¹ / ₄ , G ³ / ₈ , G ¹ / ₂ , G ³ / ₄	29.5 ... 3,300	Knurled screw	gr
Corrosion-resistant								
Stainless steel	Exhaust air one-way flow control function	CRGRLA	Elbow outlet	M5, G ¹ / ₈ , G ¹ / ₄ , G ³ / ₈ , G ¹ / ₂	M5, G ¹ / ₈ , G ¹ / ₄ , G ³ / ₈ , G ¹ / ₂	95 ... 2,100	Slotted head screw	crgrla
Precision one-way flow control valve								
Metal	One-way flow control function	GRP	–	G ¹ / ₈	G ¹ / ₈	40.7 ... 75.8	Rotary knob with scale	grp
				PK-3, PK-4	PK-3, PK-4	3.8 ... 75.8	Rotary knob with scale	grp
M5 Compact System								
Metal	One-way flow control function	GRF	–	PK-3	PK-3	45	Knurled screw	grf
Function combination								
Metal	Exhaust air one-way flow control function	GRXA	Elbow outlet	QS-4, QS-6, QS-8	G ¹ / ₈ , G ¹ / ₄	130 ... 280	Slotted head screw	grxa
Polymer	Exhaust air one-way flow control function	VFOF	Elbow outlet	QS-6, QS-8	G ¹ / ₈ , G ¹ / ₄	240 ... 590	Internal hex	614

1) Standard nominal flow rate in flow control direction at 6 bar → 5 bar.

Technical data

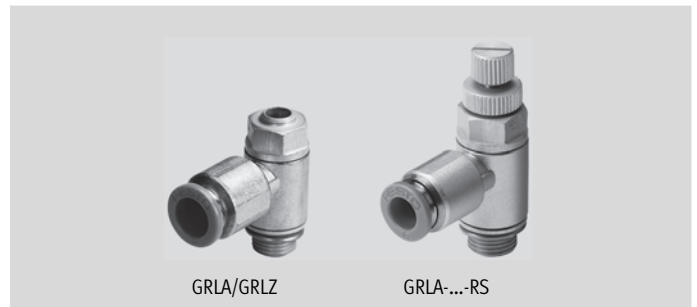
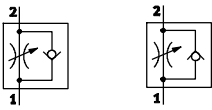

Technical data – GRLA					
Pneumatic connection 2	M5	G $\frac{1}{8}$	G $\frac{1}{4}$	G $\frac{3}{8}$	G $\frac{1}{2}$
Pneumatic connection 1	QS-3, QS-4, QS-6	QS-3, QS-4, QS-6, QS-8	QS-6, QS-8, QS-10	QS-6, QS-8, QS-10	QS-12
Valve function	Exhaust air one-way flow control function				
Adjusting element	Slotted head screw				
	Knurled screw				



Technical data – GRLZ		
Pneumatic connection 2	M5	G $\frac{1}{8}$
Pneumatic connection 1	QS-3, QS-4, QS-6	QS-3, QS-4, QS-6, QS-8
Valve function	Supply air one-way flow control function	
Adjusting element	Slotted head screw	

Operating conditions	
Operating medium	Compressed air to ISO 8573-1:2010 [7:4:4]
Note on operating/pilot medium	Operation with lubricated medium possible (in which case lubricated operation will always be required)
Operating pressure [bar]	0.2 ... 10
Ambient temperature [°C]	-10 ... +60

Materials	
Type	GRLA/GRLZ with slotted head screw GRLA-...-RS with knurled screw
Threaded plug	Wrought aluminium alloy (GRLA/GRLZ-M5: brass)
Swivel connection	Chromated die-cast zinc
Knurled head	- Anodised wrought aluminium alloy
Releasing ring	POM
Regulating screw	Brass High-alloy stainless steel
Seals	NBR

One-way flow control valves GRLA/GRLZ

★ Quick ordering

	Pneumatic connection		Standard nominal flow rate q _{nN} at 6 bar → 5 bar		Standard flow rate q _n at 6 bar → 0 bar		Part No.	Type	
			In direction of flow control	In non-return direction	In direction of flow control	In non-return direction			
	2	1	[l/min]	[l/min]	[l/min]	[l/min]			
Exhaust air one-way flow control function									
GRLA with slotted head screw									
	M5	QS-3	100	60 ... 100	145	150 ... 170	193137	GRLA-M5-QS-3-D	
		QS-4	110	65 ... 110	165	140 ... 160	193138	GRLA-M5-QS-4-D	
		QS-6	115	70 ... 110	185	145 ... 170	193139	GRLA-M5-QS-6-D	
	G1/8	QS-3	130	100 ... 130	180	200 ... 220	193142	GRLA-1/8-QS-3-D	
		QS-4	160	120 ... 190	250	270 ... 300	193143	GRLA-1/8-QS-4-D	
		QS-6	185	160 ... 240	370	330 ... 390	193144	GRLA-1/8-QS-6-D	
			400	290 ... 420	600	570 ... 680	537075	GRLA-1/8-QS-6-MF-D	
		QS-8	215	175 ... 250	400	330 ... 410	193145	GRLA-1/8-QS-8-D	
			475	325 ... 500	720	610 ... 760	537076	GRLA-1/8-QS-8-MF-D	
	G1/4	QS-6	400	290 ... 420	600	570 ... 680	193146	GRLA-1/4-QS-6-D	
		QS-8	475	325 ... 500	720	610 ... 760	193147	GRLA-1/4-QS-8-D	
		QS-10	480	345 ... 500	760	630 ... 790	193148	GRLA-1/4-QS-10-D	
	G3/8	QS-6	495	320 ... 495	740	840 ... 890	193149	GRLA-3/8-QS-6-D	
		QS-8	820	450 ... 850	1,300	1,080 ... 1,420	193150	GRLA-3/8-QS-8-D	
		QS-10	900	540 ... 975	1,400	1,160 ... 1,620	193151	GRLA-3/8-QS-10-D	
	G1/2	QS-12	1,580	925 ... 1,605	2,220	1,910 ... 2,500	193152	GRLA-1/2-QS-12-D	
	GRLA with knurled screw								
		M5	QS-3	100	60 ... 100	145	150 ... 170	197576	GRLA-M5-QS-3-RS-D
QS-4			110	65 ... 110	165	140 ... 160	197577	GRLA-M5-QS-4-RS-D	
QS-6			115	70 ... 110	185	145 ... 170	197578	GRLA-M5-QS-6-RS-D	
G1/8		QS-3	130	100 ... 130	180	200 ... 220	197579	GRLA-1/8-QS-3-RS-D	
		QS-4	160	120 ... 190	250	270 ... 300	197580	GRLA-1/8-QS-4-RS-D	
		QS-6	185	160 ... 240	370	330 ... 390	197581	GRLA-1/8-QS-6-RS-D	
		QS-8	215	175 ... 250	400	330 ... 410	534337	GRLA-1/8-QS-8-RS-D	
G1/4		QS-6	400	290 ... 420	600	570 ... 680	534338	GRLA-1/4-QS-6-RS-D	
		QS-8	475	325 ... 500	720	610 ... 760	534339	GRLA-1/4-QS-8-RS-D	
		QS-10	480	345 ... 500	760	630 ... 790	534340	GRLA-1/4-QS-10-RS-D	
G3/8		QS-6	495	320 ... 495	740	840 ... 890	534341	GRLA-3/8-QS-6-RS-D	
		QS-8	820	450 ... 850	1,300	1,080 ... 1,420	534342	GRLA-3/8-QS-8-RS-D	
		QS-10	900	540 ... 975	1,400	1,160 ... 1,620	534343	GRLA-3/8-QS-10-RS-D	
G1/2		QS-12	1,580	925 ... 1,605	2,220	1,910 ... 2,500	534344	GRLA-1/2-QS-12-RS-D	
Supply air one-way flow control function									
GRLZ with slotted head screw									
		M5	QS-3	100	60 ... 100	135	130 ... 160	193153	GRLZ-M5-QS-3-D
			QS-4	110	65 ... 110	160	150 ... 180	193154	GRLZ-M5-QS-4-D
	QS-6		115	70 ... 110	170	160 ... 200	193155	GRLZ-M5-QS-6-D	
	G1/8	QS-3	130	100 ... 130	200	180 ... 200	193156	GRLZ-1/8-QS-3-D	
		QS-4	160	120 ... 190	300	260 ... 290	193157	GRLZ-1/8-QS-4-D	
		QS-6	185	160 ... 240	340	390 ... 460	193158	GRLZ-1/8-QS-6-D	
		QS-8	215	175 ... 250	370	390 ... 470	193159	GRLZ-1/8-QS-8-D	

Technical data

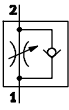

Technical data		
Pneumatic connection 2	G1/8	G1/4
Pneumatic connection 1	QS-6	QS-8
Valve function	Exhaust air one-way flow control function	
Adjusting element	Internal hex	

Operating conditions		
Operating medium	Compressed air to ISO 8573-1:2010 [7:4:4]	
Note on operating/pilot medium	Operation with lubricated medium possible (in which case lubricated operation will always be required)	
Operating pressure [bar]	0.2 ... 10	
Ambient temperature [°C]	-10 ... +60	

Materials	
Housing	PBT
Hollow bolt	Wrought aluminium alloy
Sleeve	Wrought aluminium alloy
Releasing ring	POM
Regulating screw	Brass
Seals	NBR

Ordering data

	Pneumatic connection		Standard nominal flow rate q _N at 6 bar → 5 bar		Standard flow rate q _n at 6 bar → 0 bar		Part No.	Type
			In direction of flow control	In non-return direction	In direction of flow control	In non-return direction		
	2	1	[l/min]	[l/min]	[l/min]	[l/min]		
	G1/8	QS-6	250	150 ... 260	420	460 ... 540	1526931	VFOF-LE-H-G18-Q6
	G1/4	QS-8	650	300 ... 650	1,100	840 ... 1,100	1505391	VFOF-LE-H-G14-Q8

One-way flow control valves VFOF, function combination

FESTO

Technical data

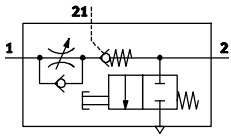

Technical data		
Pneumatic connection 2	G $\frac{1}{8}$	G $\frac{1}{4}$
Pneumatic connection 1	QS-6	QS-8
Pilot air connection 21	QS-6	QS-8
Valve function	Exhaust air one-way flow control function	
Adjusting element	Internal hex	
Actuation type	Manual	
Type of actuation, piloted non-return function	Pneumatic	
Manual exhaust function	Non-detenting	

Operating conditions		
Operating/pilot medium	Compressed air to ISO 8573-1:2010 [7:4:4]	
Note on operating/pilot medium	Operation with lubricated medium possible (in which case lubricated operation will always be required)	
Operating pressure [bar]	0.2 ... 10	
Pilot pressure [bar]	2 ... 10	
Ambient temperature [°C]	-10 ... +60	

Materials	
Housing	PBT
Cap	PBT
Hollow bolt	Wrought aluminium alloy
Sleeve	Wrought aluminium alloy
Releasing ring	POM
Regulating screw	Brass
Cover	ES-BE
Seals	NBR

Ordering data

	Pneumatic connection		Pilot air connection	Standard nominal flow rate q _{nN} at 6 bar → 5 bar		Standard flow rate q _n at 6 bar → 0 bar		Part No.	Type
				In direction of flow control	In non-return direction	In direction of flow control	In non-return direction		
	2	1	21	[l/min]	[l/min]	[l/min]	[l/min]		
	G $\frac{1}{8}$	QS-6	QS-6	240	150 ... 230 120 ... 220 ¹⁾	420	400 ... 460 400 ... 460 ¹⁾	8001459	VFOF-LE-BAH-G18-Q6
	G $\frac{1}{4}$	QS-8	QS-8	590	315 ... 540 310 ... 540 ¹⁾	940	830 ... 1,000 840 ... 1,000 ¹⁾	1927030	VFOF-LE-BAH-G14-Q8

1) Unactuated



- Reduces noise generation
- Can be screwed into the exhaust controls of control valves and drives
- Connecting thread from M5 ... R1/4

→ www.festo.com/catalogue/vffk

Technical data

Technical data	
Pneumatic port 1	M5 M7 R1/8 R1/4
Valve function	Flow control/silencer function
Adjusting element	Knurled screw
Type of seal on threaded plug	Sealing ring Coating

Operating conditions

Operating medium	Compressed air to ISO 8573-1:2010 [7:4:4]
Note on operating/pilot medium	Lubricated operation possible
Operating pressure [bar]	0 ... 10
Ambient temperature [°C]	0 ... +60

Materials

Materials	
Pneumatic port 1	M5 M7 R1/8 R1/4
Silencer insert	PE
Threaded plug	Nickel-plated brass
Regulating screw	Nickel-plated brass
Knurled nut	Aluminium
Seals	NBR -

Ordering data

	Pneumatic connection 1	Standard flow rate qn at 6 bar → 0 bar [l/min]	Part No.	Type
	M5	0 ... 80	133140	VFFK-C-K-M5-P
	M7	0 ... 100	133141	VFFK-C-K-M7-P
	R1/8	0 ... 270	133142	VFFK-C-K-R18-P
	R1/4	0 ... 420	133143	VFFK-C-K-R14-P

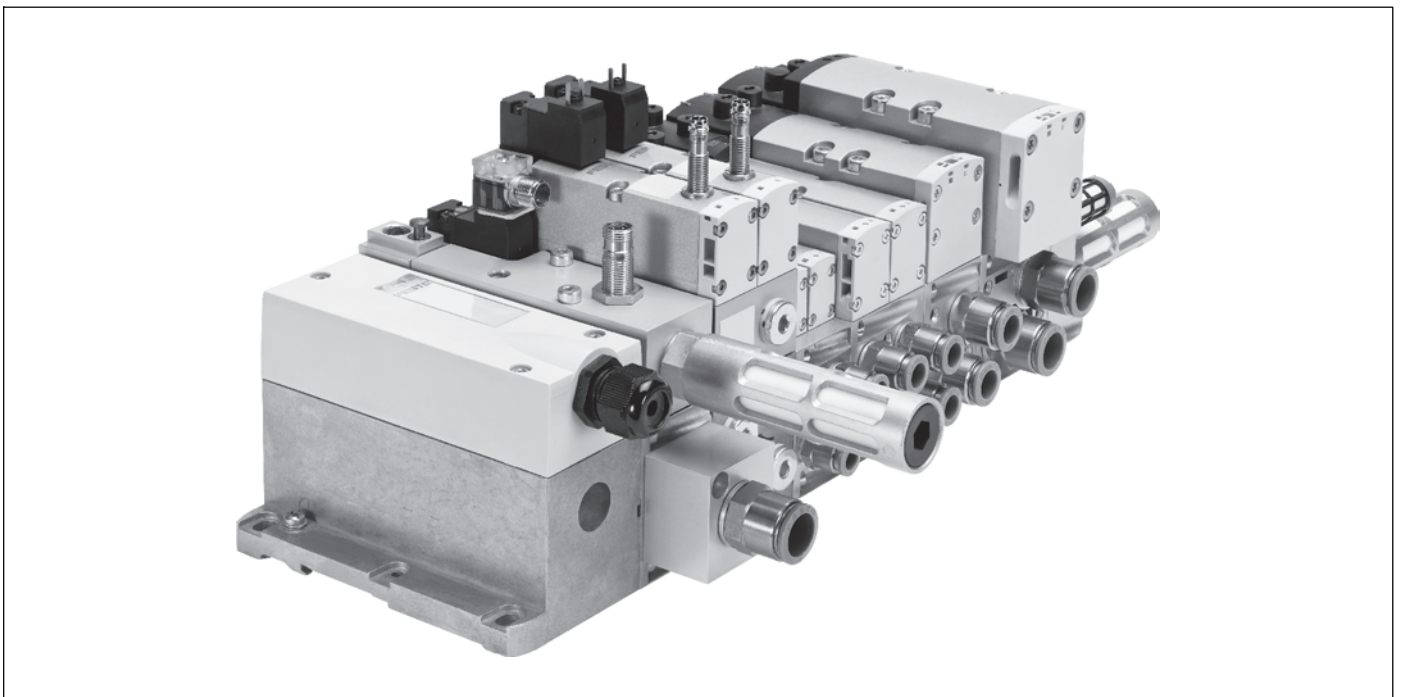

9 Valve terminals



Software tool





<p>Product finder for valve terminals</p>		<p>Find the right valve terminal quickly with the help of the product finder. Start the product finder via the blue icons in the product tree. Select your technical features on the left-hand side step-by-step; the selection of suitable products on the right-hand side is automatically updated to reflect the chosen technical features.</p>	<p>The use of logic checks ensures that only correct configurations are available for selection. The product finder for valve terminals is part of the electronic catalogue and is not available as a separate software program.</p>
--	--	--	--

Standard valve terminals





<p>Type</p>	 <p>Valve terminal, to ISO 15407-1 VTIA</p>	 <p>Valve terminal, to ISO 15407-2/ISO 5599-2 VTSA</p>
Width	18 mm, 26 mm	18 mm, 26 mm, 42 mm, 52 mm, 65 mm
Standard nominal flow rate	400 ... 1,000 l/min	400 ... 4,000 l/min
Max. no of valve positions	16	32
Electrical actuation	Individual connection	Ethernet, fieldbus, multi-pin plug, electrical terminal CPX, integrated controller, individual connection, AS-Interface connection
Valve terminal design	Modular, valve sizes can be mixed	Modular, valve sizes can be mixed
Description	<ul style="list-style-type: none"> Sturdy and flexible valve terminal Two valve sizes can be combined Wide range of individual electrical connections 	<ul style="list-style-type: none"> Sturdy and flexible valve terminal Valve widths 18 mm, 26 mm, 42 mm and 52 mm can be combined on a single valve terminal without an adapter Integrated safety functions
→ Page/online	vtia	622

9

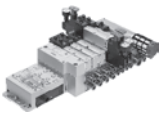

Universal valve terminals

<p>Type</p>	 <p>Valve terminal with individual electrical connection VTUG</p>	 <p>Valve terminal with multi-pin plug or fieldbus connection VTUG</p>	 <p>Valve terminal VTUB</p>	 <p>Valve terminal MPA-L</p>
Width	10 mm, 14 mm	10 mm, 14 mm	20 mm	10 mm, 14 mm, 20 mm
Standard nominal flow rate	80... 780 l/min	130 ... 630 l/min	200 ... 1,000 l/min	0 ... 870 l/min
Max. no of valve positions	16	24	16	32
Electrical actuation	Individual connection	Multi-pin plug, I-Port interface, IO-Link, fieldbus	Multi-pin plug, I-Port interface, IO-Link, fieldbus	Fieldbus, multi-pin plug, control block, electrical terminal CPX, IO-Link, I-Port
Valve terminal design	Fixed grid	Fixed grid	Fixed grid	Modular, valve sizes can be mixed
Description	<ul style="list-style-type: none"> Sturdy and durable metal components Connection technology easy to change via the E-box Wide range of valve functions Connection M3, M5, M7, G1/8 Push-in connector 3, 4, 6, 8 mm Protection class IP40/IP65 	<ul style="list-style-type: none"> Sturdy and durable metal components Excellent price/performance ratio Connection M5, M7, G1/8 Push-in connector 3, 4, 6, 8 mm Protection class IP40/IP67 	<ul style="list-style-type: none"> Outstanding economy Easy to operate Optimised for basic applications 	<ul style="list-style-type: none"> Highly modular and versatile Easily expandable in single steps Plastic sub-bases Protection class IP65
→ Page/online	570	643	vtub	661



Universal valve terminals

Type	 Valve terminal MPA-S	 Valve terminal MPA-F	 Valve terminal VTSA-F	 Valve terminal, Compact Performance CPV
Width	10 mm, 20 mm	10 mm, 20 mm	18 mm, 26 mm, 42 mm, 52 mm, 65 mm	10 mm, 14 mm, 18 mm
Standard nominal flow rate	0 ... 700 l/min	0 ... 900 l/min	700 ... 4,000 l/min	0 ... 1,600 l/min
Max. no of valve positions	64	64	32	8
Electrical actuation	Fieldbus, multi-pin plug, control block, electrical terminal CPX, AS-Interface, CP installation system, individual connection	Fieldbus, multi-pin plug, control block, electrical terminal CPX	Ethernet, fieldbus, multi-pin plug, electrical terminal CPX, integrated controller, individual connection, AS-Interface connection	AS-Interface, CP installation system, individual connection, fieldbus, multi-pin plug, IO-Link, I-Port
Valve terminal design	Modular, valve sizes can be mixed	Modular, valve sizes can be mixed	Modular, valve sizes can be mixed	Fixed grid
Description	<ul style="list-style-type: none"> • Compact dimensions • Two valve sizes can be combined • Excellent communication options thanks to serial linking 	<ul style="list-style-type: none"> • Optimised for high flow rates • Two valve sizes can be combined • Excellent communication options thanks to serial linking 	<ul style="list-style-type: none"> • Sturdy and flexible valve terminal • Valve widths 18 mm, 26 mm, 42 mm and 52 mm can be combined on a single valve terminal without an adapter • Integrated safety functions 	<ul style="list-style-type: none"> • Cubic design: maximum performance in the minimum of space • Three sizes • Wide range of connection and mounting options
→ Page/online	mpa-s	mpa-f	vtsa	cpv

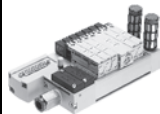



Universal valve terminals

Type	 Valve terminal, Smart Cubic CPV-SC	 Valve terminal, Smart Cubic CPA-SC	 Valve terminal VTUB-12
Width	10 mm	10 mm	12 mm, 24 mm
Standard nominal flow rate	170 l/min	120 ... 180 l/min	230 ... 400 l/min
Max. no of valve positions	16	24	35
Electrical actuation	CP installation system, individual connection, fieldbus, multi-pin plug	Individual connection, fieldbus, multi-pin plug	Multi-pin plug, I-Port interface, IO-Link, fieldbus
Valve terminal design	Fixed grid	Fixed grid	Fixed grid
Description	<ul style="list-style-type: none"> • Compact format • Optimised flow rates • Clear design 	<ul style="list-style-type: none"> • Compact dimensions • Wide range of individual electrical connections • Choice of pneumatic connection directions 	<ul style="list-style-type: none"> • Compact dimensions • Sturdy poppet valve • Flexible and low-cost fieldbus modules
→ Page/online	cpv-sc	cpa-sc	vtub-12





Application-specific valve terminals

Type	 Valve terminal VTOC	 Valve terminal MH1	 Valve terminal CDVI
Width	10 mm	10 mm	24 mm
Standard nominal flow rate	10 l/min	10 l/min	300 ... 650 l/min
Max. no of valve positions	24	24	16
Electrical actuation	Multi-pin plug, I-Port interface, IO-Link, fieldbus	Individual connection, multi-pin plug	Fieldbus, multi-pin plug
Valve terminal design	Fixed grid	Fixed grid	Modular
Description	<ul style="list-style-type: none"> • Compact pilot valves for process valves • Various electrical and pneumatic interfaces • Basis for customised adaptations 	<ul style="list-style-type: none"> • Extremely small valves • Low switching noise • Versatile pneumatic connections 	<ul style="list-style-type: none"> • Hygienic • Corrosion-resistant • Easy to clean (Clean Design)
→ Page/online	vtoc	mh1	cdvi



Electrical peripherals

Type	 Fieldbus module CTEU	 CPI installation system CTEC	 Terminal CPX	 Control block CPX-FEC
Max. no. of inputs	128	128	Digital 512, analogue 32	512
Max. no. of outputs	128	128	Digital 512, analogue 18	512
No. of module positions	32	Max. 4 installation strings, max. 4 CP modules per string	Max. 9 electric input/output modules	1
Electrical actuation	CANopen, DeviceNet, CC-Link, PROFIBUS, EtherCAT, I-Port	Fieldbus, integrated controller	Fieldbus, integrated controller	EasyIP, HTTP, Modbus TCP, TCP/IP
Description	<ul style="list-style-type: none"> For valve terminals VTUB-12, VTUG, MPA-L, CPV For installation system CTEL Versatility thanks to high protection class IP65/67 Fieldbus-typical LEDs, interfaces and switching elements available Isolated power supply for electronics and valves Optional basic diagnostics: undervoltage, short circuit Optionally expandable for low-cost, decentralised installation of two additional valve terminals with I-Port 	<ul style="list-style-type: none"> Complete concept for decentralised machine and system structure Combination of centralised and decentralised installation possible with electrical terminal CPX Decentralised pneumatic components and sensors for fast processes Centralised electrical components for fieldbus and common power supply With valve terminal CPV, MPA, CPV-SC 	<ul style="list-style-type: none"> Centralised, decentralised, hybrid installation system with maximum modularity and flexibility IP65 and IP67 or IP20 Choice of plastic or metal housing with individual linking Open to common fieldbus protocols and Ethernet Integrated diagnostic and service function Operating modes: stand-alone as remote I/O or with valve terminals MPA, VTSA/VTSA-F 	<ul style="list-style-type: none"> Modular I/O system, up to 512 I/Os – full flexibility via CPX Comprehensive solutions for diagnostics and condition monitoring Stand-alone open-loop and closed-loop control Pre-processing with all common fieldbus/Ethernet protocols (remote control) – fast, stand-alone processes on site
→ Page/online	cteu	ctec	677	688

Electrical peripherals

Type	 Control block CPX-CEC	 Control block CPX-CEC-C1	 Control block CPX-CEC-M1	 Input/output module, input module CPX-L-8DE-8DA, CPX-L-16DE
Max. no. of inputs	512	512	512	8, 16
Max. no. of outputs	512	512	512	8
No. of module positions			1	
Electrical actuation	CoDeSys Level 2, EasyIP, Modbus TCP, TCP/IP	CoDeSys Level 2, EasyIP, Modbus TCP, TCP/IP	CoDeSys Level 2, EasyIP, Modbus TCP, TCP/IP	
Description	<ul style="list-style-type: none"> Programming with CoDeSys to IEC 61131-3 Easy actuation of valve terminal configurations with MPA, VTSA Connection to all fieldbuses as a remote controller and for pre-processing Diagnostics with flexible monitoring options for pressure, flow rate, cylinder operating time, air consumption RS232 communication function Data interface: socket, Sub-D, 9-pin 	<ul style="list-style-type: none"> Programming with CoDeSys to IEC 61131-3 Easy actuation of valve terminal configurations with MPA, VTSA Connection to all fieldbuses as a remote controller and for pre-processing Diagnostics with flexible monitoring options for pressure, flow rate, cylinder operating time, air consumption Actuation of electric drives as individual axes via CANopen Motion functions for electric drives Fieldbus interface: CAN Bus; up to 31 CANopen slaves can be connected 	<ul style="list-style-type: none"> Programming with CoDeSys to IEC 61131-3 Easy actuation of valve terminal configurations with MPA, VTSA Connection to all fieldbuses as a remote controller and for pre-processing Diagnostics with flexible monitoring options for pressure, flow rate, cylinder operating time, air consumption Actuation of electric drives as individual axes via CANopen SoftMotion functions for coordinated multi-axis movements Fieldbus interface: CAN Bus 	<ul style="list-style-type: none"> Supports connection blocks with Sub-D, terminal connection and M12 connection Internal electronic fuse per module Includes interlinking block and connection block with spring-loaded terminals Status LEDs for each input signal and fault LED Plastic design
→ Page/online	cpx-cec	689	689	cpx-l

Electrical peripherals

Type	 Output module CPX-FVDA	 Analogue module CPX-4AE-U-I	 AS-i module CESA
Max. no. of inputs		4	992
Max. no. of outputs	2		992
No. of module positions			Slaves, digital: 62, slaves, analogue: 62
Electrical actuation	Can only be used with PROFINET or PROFIBUS bus node		Fieldbus interface: PROFIBUS, CANopen
Description	<ul style="list-style-type: none"> • PROFI-safe shut-off module for interrupting the contact rails of the interlinking block for valves and outputs • Diagnostics: short circuit/overload per channel, undervoltage at valves, cross circuit, wire break per channel 	<ul style="list-style-type: none"> • For actuating devices with a standardised analogue interface such as sensors for pressure, temperature, flow rate, filling level, etc. • Supports connection blocks with M12, Sub-D and terminal connection • Voltage for electronics and sensors supplied via interlinking block 	<ul style="list-style-type: none"> • AS-i master gateway • Duplicate address recognition • Direct operation • Graphical display • Comprehensive diagnostics via LED and display • Specification 3.0
→ Page/online	689	689	cesa

Customised components – for your specific requirements



Valve terminals with customised designs

Can't find the valve terminal you need in our catalogue? We can offer you customised components that are tailored to your specific requirements – from minor product modifications to complete new product developments.

Common product modifications:

- Coatings for special ambient conditions
- Customised cables: length, pin allocation, pre-assembled with plug
- Modified actuating elements
- Modified connecting thread
- Modified valve sub-bases

Many additional variants are possible. Ask your Festo sales engineer, who will be happy to help. Further information on customised components can be found on your local website at www.festo.com.

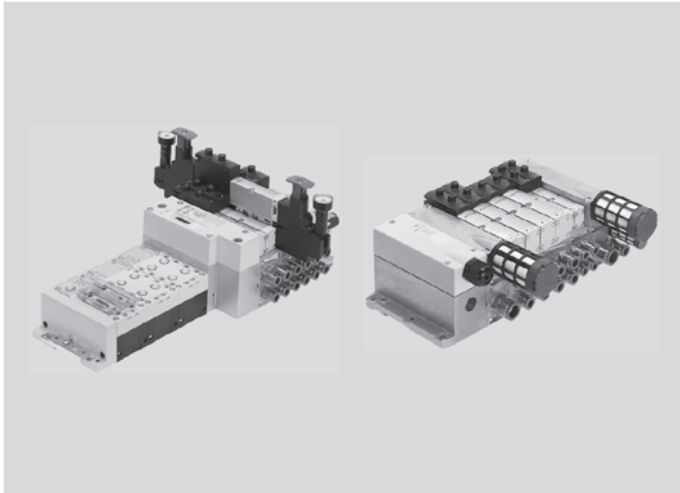

- Standard valve width 18/26/42/52/65 mm, flow rates up to 4,000 l/min
- Combination of valve sizes possible
- Modular valve terminal for up to 32 valves
- Complete and standardised valve range
- Wide range of vertical stacking modules: pressure regulator plate, flow control plate, vertical pressure shut-off plate, etc.
- Sturdy metal design
- Channel-oriented diagnostics down to the individual valve

→ www.festo.com/catalogue/vtasa

Product range overview

Electrical connection	Max. number of valve positions	Size					→ Page/ online
		18 mm (ISO 02)	26 mm (ISO 01)	42 mm (ISO 1)	52 mm (ISO 2)	65 mm (ISO 3)	
Individual electrical connection	2	■	■	■	■	–	vtasa
Electrical multi-pin plug connection, spring-loaded terminal	32	■	■	■	■	■	626
Electrical multi-pin plug connection, Sub-D (37-pin)	32	■	■	■	■	■	626
AS-interface connection	8	■	■	■	■	■	626
Fieldbus connection/control block	32	■	■	■	■	■	626

9

Valve types

VC	2x 2/2-way valve, single solenoid, normally open, pneumatic spring return	O	5/2-way valve, single solenoid, mechanical spring return	SP	5/2-way valve on intermediate plate, with plug type C individual connection and switching position sensing via PNP sensor, M8 plug	PQ	Soft-start valve, with internal pilot air supply, without proximity sensor
VV	2x 2/2-way valve, single solenoid, normally open, pneumatic spring return, vacuum operation possible at 3 and 5	J	5/2-way valve, double solenoid	SN	5/2-way valve on intermediate plate, with plug type C individual connection and switching position sensing via NPN sensor, M8 plug	PP	Soft-start valve, with internal pilot air supply, with proximity sensor PNP
N	2x 3/2-way valve, normally open	D	5/2-way valve, double solenoid, with dominant signal	SO	5/2-way valve, single solenoid, with spring return and switching position sensing via PNP sensor, M8 plug	PQ	Soft-start valve, with internal pilot air supply, with proximity sensor NPN
K	2x 3/2-way valve, normally closed	B	5/3-way valve, mid-position pressurised	SQ	5/2-way valve, single solenoid, with spring return and switching position sensing via NPN sensor, M8 plug	PN	Soft-start valve, with external pilot air supply, without proximity sensor
H	2x 3/2-way valve, 1x normally open, 1x normally closed	G	5/3-way valve, mid-position closed	SS	5/2-way valve, single solenoid, with spring return and switching position sensing via PNP sensor, 0.5 m cable and M12 plug	PM	Soft-start valve, with external pilot air supply, with proximity sensor PNP
P	2x 3/2-way valve, normally open, reverse operation	E	5/3-way valve, mid-position exhausted			PK	Soft-start valve, with external pilot air supply, with proximity sensor NPN
Q	2x 3/2-way valve, normally closed, reverse operation	VG	5/3-way valve, flow from 1 to 2 in mid-position, closed in 4			L	Blanking plate for vacant position
R	2x 3/2-way valve, 1x normally open, 1x normally closed, reverse operation	SA	5/3-way valve, mid-position exhausted, switching position 14 detenting, pneumatic spring return				
M	5/2-way valve, single solenoid, pneumatic spring return	SB	5/3-way valve, mid-position 1x exhausted/1x pressurised, switching position 14 detenting, pneumatic spring return				

Note

Valve terminals can be ordered quickly and easily online. The convenient product configurator can be found at:

→ www.festo.com/catalogue/vtasa

Key features

Innovative

- High-performance valves in a sturdy metal housing
- Five valve sizes on one valve terminal (width 65 mm with adapter)
- Standardised from the multi-pin plug to the fieldbus connection and control block
- Dream team: fieldbus valve terminal suitable for CPX electrical peripherals. This means:
 - Forward-looking internal communication system for actuating the valves and CPX modules
 - Four valve sizes on one valve terminal without adapters
- Valve functions for integration in control architectures of higher categories to EN ISO 13849-1

Versatile

- Modular system offering a range of configuration options
- Expandable with up to 32 solenoid coils
- Conversions and extensions possible at a later date
- Manifold sub-bases can be extended using four screws, sturdy duct separation on metal support
- Integration of innovative function modules possible
- Supply plates enable a flexible air supply and variable pressure zones
- Reverse operation
- High pressure range
 - 0.9 ... 10 bar,
 - flow range 550 ... 4,000 l/min
- Wide range of valve functions
- Valve supply: 24 V DC or 110 V AC

Reliable

- Sturdy and durable metal components
 - Valves
 - Manifold sub-bases
 - Seals
- Fast troubleshooting thanks to LEDs on the valves and diagnostics via fieldbus
- Reliable servicing thanks to valves that can be replaced quickly and easily
- Manual override either non-detenting, non-detenting/detenting, non-detenting/sturdy or covered
- Durable thanks to the use of tried-and-tested piston spool valves
- Large and durable labelling system
- 100% duty cycle

Easy to mount

- Ready-to-install and tested unit
- Lower selection, ordering, installation and commissioning costs
- Secure mounting on wall or H-rail

Electrical connection options

Multi-pin plug connection

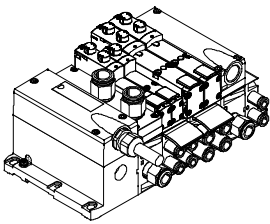

Control signals from the controller to the valve terminal are transmitted via a pre-assembled multi-wire connecting cable or a self-assembled multi-pin plug

connection, which substantially reduces installation time.

The valve terminal can be equipped with max. 32 solenoid coils.

Versions

- Multi-pin plug connection with terminal strip (spring-loaded terminal)
- Connecting cable for multi-pin plug connections, fully assembled (D-Sub)
- Sub-D plug connector for assembly by the user, 37-pin
- Round plug connector M23, 19-pin

AS-interface connection

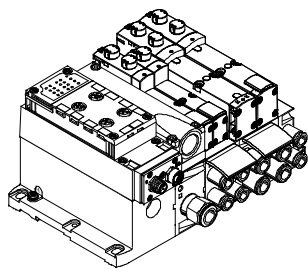

A special feature of the AS-interface is its ability to simultaneously transmit data and supply power via a two-core cable. The encoded cable profile prevents connection with incorrect polarity. The valve terminal with AS-interface is available in the following versions:

- With one to eight modular valve positions (max. 8 solenoid coils). This corresponds to 1 to 8 VTSA valves.
- With all available valve functions.

The connection technology used for the inputs can be selected as with CPX: M8, M12, quick connection, Sub-D, spring-loaded terminal (terminals to IP20).

Key features

Electrical connection options

Fieldbus connection via the CPX system

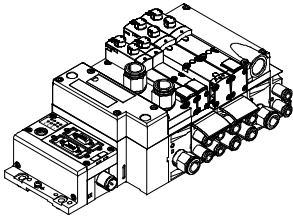

An integrated fieldbus node manages the communication connection with a higher-order PLC. This enables a space-saving pneumatic and electronic solution.

Valve terminals with fieldbus interfaces can be configured with up to 16 manifold sub-bases. With 2 solenoid coils per connection, up to 32 solenoid coils can thus be actuated.

Versions:

- EtherNet/IP
- CANopen
- DeviceNet
- INTERBUS
- CC-LINK
- PROFIBUS DP
- PROFINET
- EtherCAT

Control block connection via the CPX system

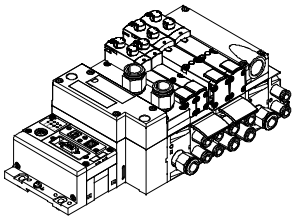

A controller integrated in the Festo valve terminal enables the construction of stand-alone control units with protection to IP65 without a control cabinet thanks to two different operating modes.

In the slave operating mode, these valve terminals can be used for intelligent preprocessing and are therefore ideal modules for designs using decentralised intelligence.

In the master operating mode, terminal groups can be designed with many options and functions that can autonomously control a medium-sized machine/system.

CP string extension

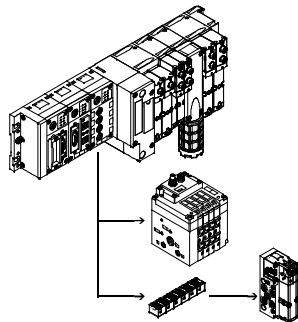

The optional CP string extension enables additional valve terminals and I/O modules to be connected to the fieldbus node of the CPX terminal on up to 4 CP strings. Different input and output modules as well as CPV-SC, CPV and CPA valve terminals can be connected. The maximum length of the CP string

extension is 10 metres, which means that the extension modules can be mounted directly on-site. All the required electrical signals are transmitted via the CP cable, which in turn means that no further installation is needed on the extension module.

One CP string offers:

- 32 input signals
- 32 output signals for output modules 24 V DC or solenoid coils
- Logic and sensor supply for the input modules
- Load voltage supply for the valve terminals
- Logic supply for the output module

Control block with safety function, width 26 mm

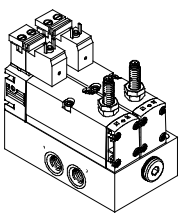

These valves are used for special applications, for example for:

- Protecting against unexpected start-up
- Reversing
- Drives in manually loaded devices

This control block is suitable for use as a press safety valve to EN 962.

This valve is a safety component in accordance with the Machinery Directive 2006/42/EC.

Key features

Modular pneumatic components

The modular design of the VTSA/VTSA-F enables maximum flexibility right from the planning stage and offers maximum ease of service in operation.

The system consists of manifold sub-bases and valves.

The manifold sub-bases are screwed together and thus form the support system for the valves.

Inside the manifold sub-bases are the connection ducts for supplying compressed air to and venting from the

valves on the terminal as well as the working ports for the pneumatic cylinders for each valve.

Each manifold sub-base is connected to the next using four screws.

Individual valve terminal sections can be isolated and further manifold blocks inserted by loosening these screws. This ensures that the valve terminal can be rapidly and reliably extended.

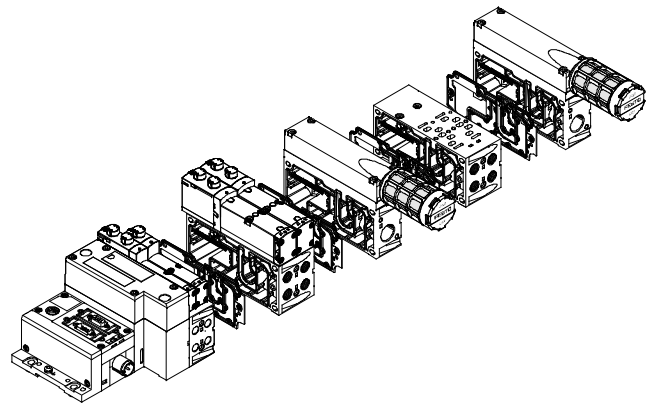
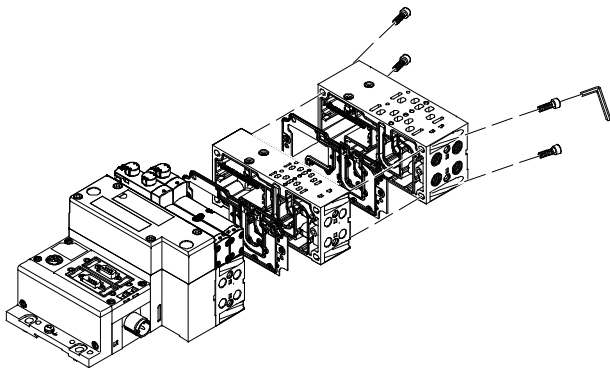

Modular electrical peripherals

The manner in which the valves are actuated differs according to whether you are using a multi-pin terminal or fieldbus terminal.

The VTSA/VTSA-F with CPX interface is based on the internal bus system of the CPX terminal and uses this communication system for all solenoid coils and a range of electrical input and output functions.

Parallel linking enables the following:

- Transmission of switching information
- High valve density
- Compact design
- Position-based diagnostics

- Separate voltage supply for valves
- Flexible conversion without address shifting
- Transmission of status, parameter and diagnostic data

VTSA with electrical peripherals CPX

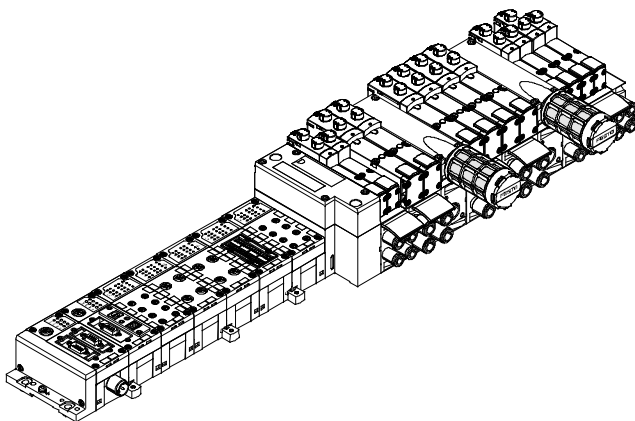

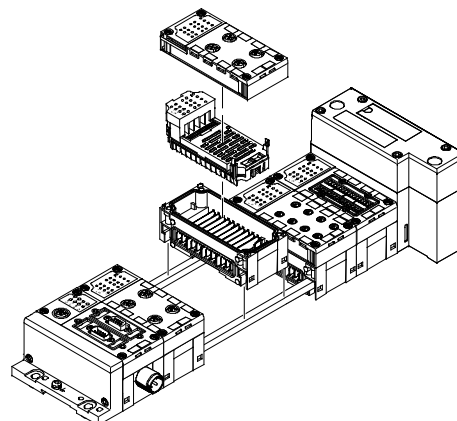

Modularity with electrical peripherals CPX



Valve terminals VTSA, to ISO 15407-2, ISO 5599-2

Technical data

-  - Flow rate
 Width 18 mm:
 Up to 550 (700)¹⁾ l/min
-  - Operating voltage
 24 V DC
 110 V AC
- Width 26 mm:
 Up to 1,100 (1,300)¹⁾ l/min
- Width 42 mm:
 Up to 1,300 l/min
- Width 52 mm:
 Up to 2,900 l/min

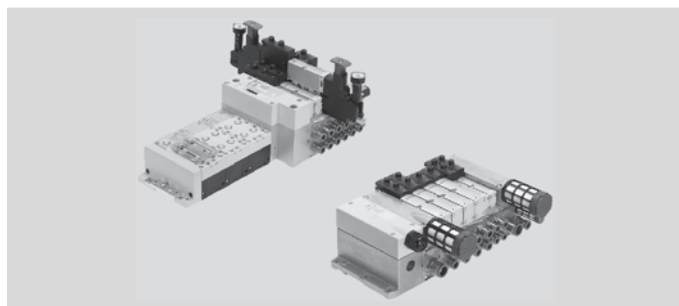

1) Flow rate in brackets applies to VTSA-F

Technical data		Download CAD data → www.festo.com	
Design		Piston spool valve	
Width	[mm]	18/26/42/52	
Lubrication		Life-time lubrication	
Type of mounting		Wall mounting On H-rail to EN 60715	
Manual override		Non-detenting, detenting, covered	
Pneumatic connection		Via manifold sub-base	
Supply port	1	G ¹ / ₂ , QS-G ¹ / ₂ -12, QS-G ¹ / ₂ -16	
Exhaust port	3.5	G ¹ / ₂ , QS-G ¹ / ₂ -12, QS-G ¹ / ₂ -16	
Working ports (dependent on the connection type)	Width 18 mm (ISO 02)	2.4	G ¹ / ₈
	Width 26 mm (ISO 01)	2.4	G ¹ / ₄
	Width 42 mm (ISO 1)	2.4	G ³ / ₈
	Width 52 mm (ISO 2)	2.4	G ¹ / ₂
External pilot air port	12, 14	G ¹ / ₄	

9

Technical data		Download CAD data → www.festo.com														
Valve function/order code		N	K	H	P	Q	R	M	O	J	D	B	G	E	VC	VV
Valve switching times [ms]																
Width 18 mm (ISO 02), nominal operating voltage 24 V DC/110 V AC	On	12	12	12	25	25	25	22	12	-	-	15	15	15	12	12
	Off	30	30	30	12	12	12	28	38	-	-	44	44	44	30	30
	Changeover	-	-	-	-	-	-	-	-	11	13	-	-	-	-	-
Width 26 mm (ISO 01), nominal operating voltage 24 V DC/110 V AC	On	20	20	20	32	32	32	25	20	-	-	22	22	22	20	20
	Off	38	38	38	30	30	30	45	65	-	-	65	65	65	38	38
	Changeover	-	-	-	-	-	-	-	-	18	21	-	-	-	-	-
Width 42 mm (ISO 1), nominal operating voltage 24 V DC	On	20	20	20	34	34	34	27	22	-	-	22	22	22	20	20
	Off	38	38	38	28	28	28	45	60	-	-	65	65	65	38	38
	Changeover	-	-	-	-	-	-	-	-	16	19	-	-	-	-	-
Width 42 mm (ISO 1), nominal operating voltage 110 V AC	On	22	22	22	34	34	34	20	20	-	-	22	22	22	22	22
	Off	46	46	46	38	38	38	55	55	-	-	68	68	68	46	46
	Changeover	-	-	-	-	-	-	-	-	16	19	-	-	-	-	-
Width 52 mm (ISO 2), nominal operating voltage 24 V DC	On	20	20	20	30	30	30	40	20	-	-	23	23	23	14	-
	Off	35	35	35	30	30	30	45	60	-	-	60	60	60	35	-
	Changeover	-	-	-	-	-	-	-	-	18	18	-	-	-	-	-
Width 52 mm (ISO 2), nominal operating voltage 110 V AC	On	35	35	35	50	50	50	70	25	-	-	30	30	30	35	-
	Off	70	70	70	65	65	65	90	110	-	-	100	100	100	70	-
	Changeover	-	-	-	-	-	-	-	-	35	42	-	-	-	-	-
Standard nominal flow rate on valve terminal [l/min]																
Width 18 mm (ISO 02)		400					550			450			500			
Width 26 mm (ISO 01)		900					1,100			1,000			1,000			
Width 42 mm (ISO 1)		1,200					1,300			1,200			1,400			
Width 52 mm (ISO 2)		2,400					2,900			2,800			2,800			

Technical data



Operating conditions		N	K	H	P	Q	R	M	O	J	D	B	G	E	VC	W	
Valve function/order code																	
Operating medium		Compressed air to ISO 8573-1:2010 [7:4:4]															
Pilot medium		Compressed air to ISO 8573-1:2010 [7:4:4]															
Note on operating/pilot medium		Lubricated operation possible (in which case lubricated operation will always be required)															
Ambient temperature	[°C]	-5 ... +50															
Temperature of medium	[°C]	-5 ... +50															
Operating pressure	[bar]	3 ... 10			-0.9 ... +10										3 ... 10		-0.9 ... +10
Operating pressure for valve terminal with internal pilot air supply	[bar]	3 ... 10															
Pilot pressure	[bar]	3 ... 10															

Electrical data – VTSA with CPX terminal		N	K	H	P	Q	R	M	O	J	D	B	G	E	VC	W
Valve function/order code																
Power supply for electronics (U _{EL/SEN})																
Operating voltage	[V DC]	24 ±10%														
Max. intrinsic current consumption at 24 V DC	[mA]	20														
Duty cycle		100%														
Load voltage supply for valves (U _{val})																
Operating voltage	[V DC]	24 ±10%														
Duty cycle		100%														
Protection class to EN 60529		IP65 (for all types of signal transmission in assembled state)														
Power consumption	[W]	1.3			1.6			1.3		1.6		1.3				

Pneumatic connection sizes		
Right-hand end plate (duct 12, 14)	Code V, X	G $\frac{1}{4}$
	Code V1, V3, X1, X3	G $\frac{1}{4}$
Right-hand end plate (duct 1, 3, 5)	Code V, X	G $\frac{1}{2}$
	Code V1, V3, X1, X3	G $\frac{3}{4}$
Left-hand supply plate (duct 1, 3, 5)		G $\frac{1}{2}$
Manifold sub-base (duct 2, 4)	Width 18 mm	G $\frac{1}{8}$
	Width 26 mm	G $\frac{1}{4}$
	Width 42 mm	G $\frac{3}{8}$
	Width 52 mm	G $\frac{1}{2}$

Materials	
Manifold sub-base	Die-cast aluminium
Valve	Die-cast aluminium, PA reinforced
Seals	NBR, elastomer (support made of steel)
Supply plate	Die-cast aluminium
Right-hand end plate	Die-cast aluminium
Pneumatic interface for CPX	Die-cast aluminium
Flow control plate	Die-cast aluminium
Pressure regulator plate	Die-cast aluminium, PA reinforced
Multi-pin connection block	Die-cast aluminium
Cover for the pneumatic interface and multi-pin plug connection	PA reinforced

Technical data – Control block, VOFA

-  - Flow rate
Up to 950 l/min
-  - Operating voltage
24 V DC
-  - Operating pressure
3 ... 10 bar

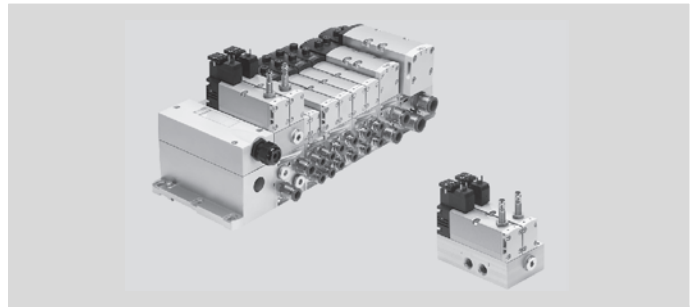

Description

The control block is designed for two-channel actuation of pneumatic drive components such as double-acting linear cylinders, for example, and can be used to realise the following protective measures:

- Protection against unexpected start-up (EN 1037)
- Reversing hazardous movements, provided the reversing motion will not result in further hazards

The control attributes of the control block enable Performance Level e to be achieved for the safety measures. The control block has been developed and manufactured in accordance with the basic and proven safety principles of EN ISO 13849-1 and EN ISO 13849-2.

The requirements of EN ISO 13849-1 and EN ISO 13849-2 (e.g. CCF, DC) must be taken into consideration for implementing and operating the component and for use in higher categories (2 to 4). When using this product in machines or systems subject to specific C standards, the requirements specified in these standards must be observed.

The control block with safety function is designed for installation in machines and automation systems and must only be used in industrial applications (high-demand mode).

The control block with safety function is suitable for use as a press safety valve to EN 962.

Decentralised individual connection variant

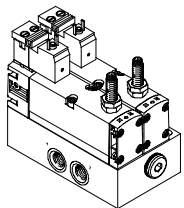

Two solenoid valves on manifold sub-base with square plugs and integrated piston position sensing.

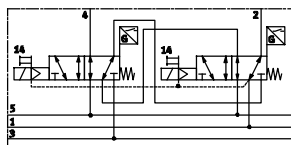

Function – Pneumatic/electrical interlinking

The safety function is achieved through two-channel pneumatic interlinking of two single solenoid 5/2-way valves within the control block: port (4) is only pressurised if both solenoid valves are switched to switching position (14). Port (2) is always pressurised if at least one of the two solenoid valves is in

normal position. The valve is reset via a mechanical spring.

The switching operation of the solenoid valves can be monitored by sensing the proximity sensors at the solenoid valves (switching position sensing). This is done by linking the control signal

Version for valve terminal VTSA/VTSA-F

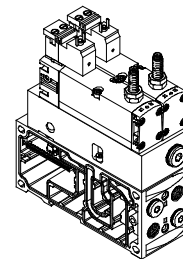

Two solenoid valves on manifold sub-base for valve terminal VTSA/VTSA-F with square plugs and integrated piston position sensing.

Electrical actuation takes place independently of the valve terminal (individual, multi-pin plug or fieldbus/control block connection) via a standardised square plug to EN 175301-803, type C.

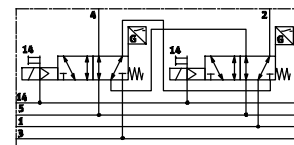

and signal change of the proximity sensor so that it is possible to check whether the piston spools of the solenoid valves are reaching or leaving the normal position (expectations).

The piston spools of the solenoid valves are designed so that pneumatic short

circuits between ports (2) and (4) are ruled out (freedom from overlap).

To achieve the required category 4 (Performance Level e, to EN ISO 13849-1), the two solenoid valves must be actuated via two separate channels.

Technical data – Control block, VOFA

Technical data		Download CAD data → www.festo.com	
Type		VOFA-L26-T52-M-G14-1C1 (individual sub-base)	VOFA-B26-T52-M-1C1 (on valve terminal)
Design	Piston spool valve		
Sealing principle	Soft		
Actuation type	Electric		
Type of control	Piloted		
Pilot air supply	Internal		Internal/external via valve terminal
Type of mounting	Via through-hole, on manifold sub-base		
Mounting position	Any		
Manual override	None		
Valve switching status display	Via accessories		
Standard nominal flow rate	[l/min]	950	830
Performance Level (PL)	Protection against manipulation, prevention of unexpected start-up (up to category 4, Performance Level e)		
	Reversing a movement/to category 4, Performance Level e		
Switching times			
Valve switching time	On	22	22
	Off	56	59
Valve sensor switching time ¹⁾	On	60	60
	Off	11	11

Operating conditions			
Type		VOFA-L26-T52-M-G14-1C1 (individual sub-base)	VOFA-B26-T52-M-1C1 (on valve terminal)
Operating medium	Compressed air to ISO 8573-1:2010 [7:4:4]		
Note on operating/pilot medium	Lubricated operation possible (in which case lubricated operation will always be required)		
Ambient temperature	[°C]	-5 ... +50	
Temperature of medium	[°C]	-5 ... +50	
Operating pressure	[bar]	3 ... 10	0 ... 10
Pilot pressure	[bar]	3 ... 10	
Max. positive test pulse with 0 signal	[µs]	1,000	
Max. negative test pulse with 1 signal	[µs]	800	

- 1) Valve sensor switching time off: period of time from coil being energised to sensor being switched off when using a PNP sensor.
Valve sensor switching time on: period of time from coil being de-energised to 0-L edge at the sensor when using a PNP sensor.

Technical data – Control block, VOFA

Electrical data – Control block		
Electrical connection		Plug to EN 175301-803, type C, without protective earth conductor
Nominal operating voltage	[V DC]	24
Power consumption	[W]	1.8 W
Max. magnetic disruption field	[mT]	60
Piston position sensing		Normal position via sensor
Duty cycle	[%]	100
Protection class to EN 60529		IP65, NEMA 4 (for all types of signal transmission in assembled state)

Electrical data – Sensor		
Electrical connection		Cable, 3-wire
		Plug M8x1, 3-pin
Cable length	[m]	2.5
Switching output		PNP or NPN
Switching element function		N/C contact
Switching status display		Yellow LED
Operating voltage range	[V DC]	10 ... 30
Sensor idle current	[mA]	Max. 10
Max. output current	[mA]	200
Voltage drop	[V]	Max. 2
Max. switching frequency	[Hz]	5,000
Measuring principle		Inductive

Pneumatic connection sizes			
Type		VOFA-L26-T52-M-G14-1C1 (individual sub-base)	VOFA-B26-T52-M-1C1 (on valve terminal)
Supply	1	G $\frac{1}{4}$	Via the manifold sub-base of the valve terminal
Exhaust	3/5, 33	G $\frac{1}{4}$	
Working ports	2/4	G $\frac{1}{4}$	
Pilot air supply	14	–	
Pressure gauge		G $\frac{1}{4}$	G $\frac{1}{4}$

Materials	
Sub-base/manifold sub-base	Wrought aluminium alloy
Valve	Die-cast aluminium, PA
Seals	NBR, FPM
Screws	Galvanised steel
Sensor housing	High-alloy stainless steel
Sensor cable sheath	PUR
Note on materials	Contains PWIS (paint-wetting impairment substances)

Accessories

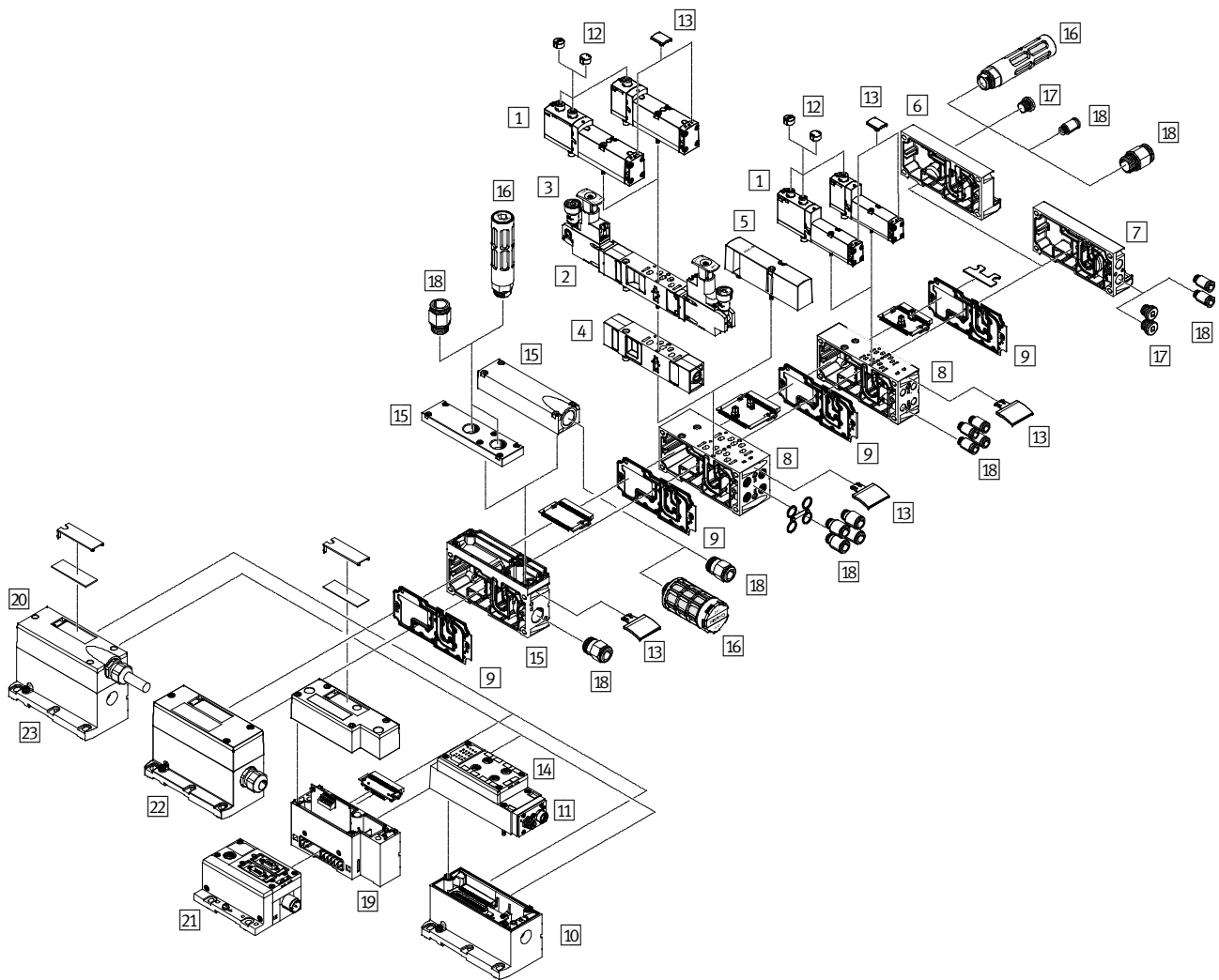

Accessories	→ Page/online
1 Solenoid valve VSVA	633
2 Regulator plate VABF	637
3 Accessories for regulator plate (pressure gauge PAGN, cartridge fitting QSP)	638
4 Additional vertical stacking modules (flow control plate, vertical supply plate or vertical pressure shut-off plate) VABF	638
5 Blanking plate VABB for vacant position	638
6 Right-hand end plate VABE with ports for supply air/exhaust air	638
7 Right-hand end plate VABE with pilot air selector	638
8 Manifold sub-base VABV	639
9 Duct separator VABD	639
10 Electrical interface VABE for AS-interface (delivery unit with 11)	639
11 AS-interface module VAEM	639
12 Cover cap VAMC for manual override non-detenting/covered	639
13 Inscription label ASCF	639

Accessories	→ Page/online
14 Manifold block CPX-AB for AS-interface	639
15 Supply plate VABF with ducted exhaust air, ports 3 and 5 separated or combined	639
16 Silencer U	640
17 Blanking plug B	640
18 Push-in fitting QS	640
19 Pneumatic interface VABA	640
20 Multi-pin plug connection NEBV/NECV with connecting cable or cover for self-assembly	640
21 Fieldbus interface CPX-FB	677
22 Multi-pin plug connection VABE with terminal strip (spring-loaded terminal)	vtsa
23 Multi-pin plug connection VABE with connecting cable for multi-pin plug connections	vtsa
- Control block VOFA	642
- Wall mounting VAME	642
- 90° connection plate VABF	642
- User documentation P.BE-VTSA	642

Accessories with individual valve connection

In applications with specific emergency stop conditions, it may be necessary to switch one or more valves separately from the valve terminal controller. Standard valves (VSVA) with individual electrical connection (round or square plug) are mounted on the valve terminal to this end.

In order for the protection class IP65 to be achieved, the functionless opening in the sub-base for the electrical connection must be sealed.

A sealing cap is available for the 18 mm and 26 mm widths. With manifold or individual sub-bases, valves with width 42 mm and 52 mm must be used with a seal to comply with the IP protection class.

For central control of the valve terminal via a multi-pin plug or fieldbus connection, the valve position occupied in this way acts like a vacant position, i.e. the assigned address in the fieldbus node or the corresponding connection in the multi-pin plug connection is occupied.

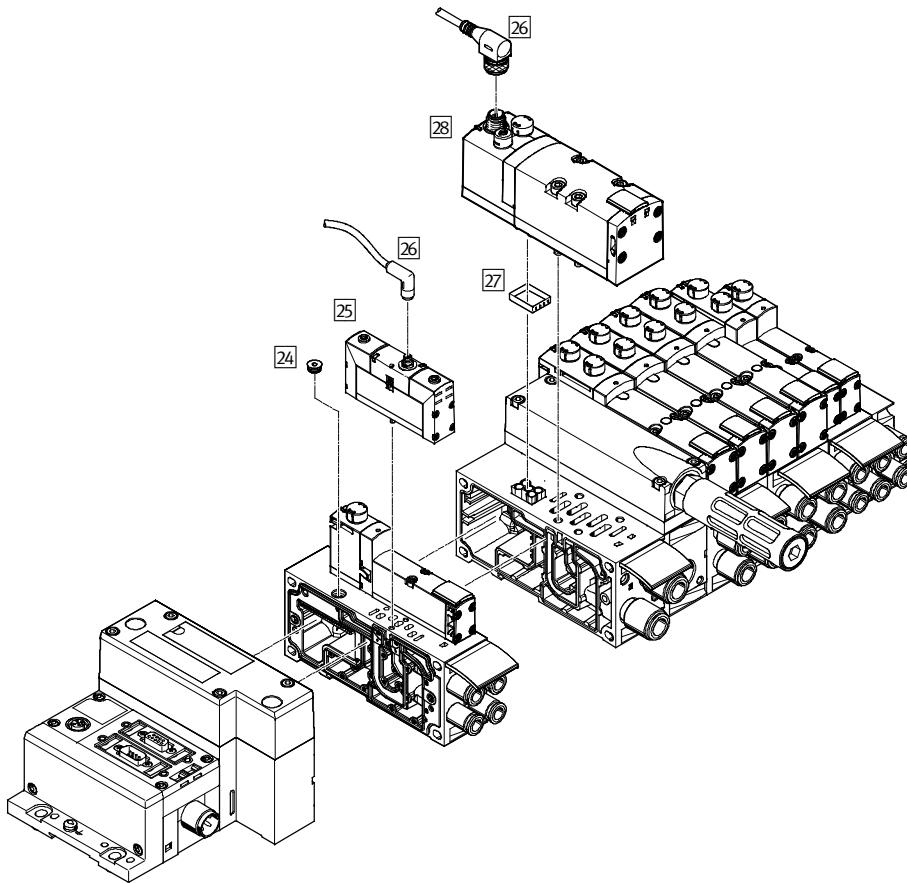

Accessories	→ Page/online
24 Sealing cap VABD	640
25 Solenoid valve VSVA to ISO15407-1	641
26 Connecting cable NEBU	641
27 Seal VABD-S2	641
28 Solenoid valve VSVA to ISO5599-1	641
- Control block VOFA	642
- Wall mounting VAME	642
- 90° connection plate VABF	642
- User documentation P.BE-VTSA	642

Accessories for valve on individual sub-base

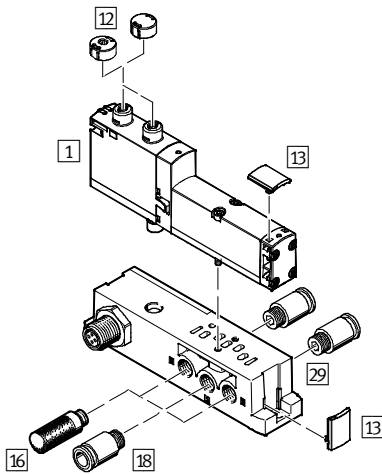

Accessories	→ Page/online
1 Solenoid valve VSVA	633
12 Cover cap VAMC for manual override	639
13 Inscription label ASCF	639
18 Push-in fitting QS	640
16 Silencer U	640
29 Individual sub-base VABS	641
- Control block VOFA	642
- Wall mounting VAME	642
- 90° connection plate VABF	642
- User documentation P.BE-VTSA	642

Accessories – Ordering data

	Code ¹⁾	Description	Part No.	Type	
	1	Solenoid valve, width 18 mm			
	VC	2x 2/2-way valve, single solenoid, normally closed, pneumatic spring	24 V DC 110/120 V AC	561155 561156	VSVA-B-T22C-AZD-A2-1T1L VSVA-B-T22C-AZD-A2-2AT1L
	VV	2x 2/2-way valve, single solenoid, normally closed, pneumatic spring, vacuum operation possible at 3 and 5	24 V DC 110/120 V AC	561159 561160	VSVA-B-T22CV-AZD-A2-1T1L VSVA-B-T22CV-AZD-A2-2AT1L
	N	2x 3/2-way valve, single solenoid, normally open	24 V DC 110/120 V AC	539178 539165	VSVA-B-T32U-AZD-A2-1T1L VSVA-B-T32U-AZD-A2-2AT1L
	K	2x 3/2-way valve, single solenoid, normally closed	24 V DC 110/120 V AC	539176 539163	VSVA-B-T32C-AZD-A2-1T1L VSVA-B-T32C-AZD-A2-2AT1L
	H	2x 3/2-way valve, single solenoid, normal position 1x open, 1x closed	24 V DC 110/120 V AC	539180 539167	VSVA-B-T32H-AZD-A2-1T1L VSVA-B-T32H-AZD-A2-2AT1L
	P	2x 3/2-way valve, single solenoid, reverse operation, normally open	24 V DC 110/120 V AC	539179 539166	VSVA-B-T32F-AZD-A2-1T1L VSVA-B-T32F-AZD-A2-2AT1L
	Q	2x 3/2-way valve, single solenoid, reverse operation, normally closed	24 V DC 110/120 V AC	539177 539164	VSVA-B-T32N-AZD-A2-1T1L VSVA-B-T32N-AZD-A2-2AT1L
	R	2x 3/2-way valve, single solenoid, reverse operation, normal position 1x open, 1x closed	24 V DC 110/120 V AC	539181 539168	VSVA-B-T32W-AZD-A2-1T1L VSVA-B-T32W-AZD-A2-2AT1L
	M	5/2-way valve, single solenoid, pneumatic spring	24 V DC 110/120 V AC	539184 539171	VSVA-B-M52-AZD-A2-1T1L VSVA-B-M52-AZD-A2-2AT1L
	O	5/2-way valve, single solenoid, mechanical spring	24 V DC 110/120 V AC	539185 539172	VSVA-B-M52-MZD-A2-1T1L VSVA-B-M52-MZD-A2-2AT1L
	J	5/2-way valve, double solenoid	24 V DC 110/120 V AC	539182 539169	VSVA-B-B52-ZD-A2-1T1L VSVA-B-B52-ZD-A2-2AT1L
	D	5/2-way valve, double solenoid, with dominant signal	24 V DC 110/120 V AC	539183 539170	VSVA-B-D52-ZD-A2-1T1L VSVA-B-D52-ZD-A2-2AT1L
	B	5/3-way valve, mid-position pressurised	24 V DC 110/120 V AC	539186 539173	VSVA-B-P53U-ZD-A2-1T1L VSVA-B-P53U-ZD-A2-2AT1L
	G	5/3-way valve, mid-position closed	24 V DC 110/120 V AC	539188 539175	VSVA-B-P53C-ZD-A2-1T1L VSVA-B-P53C-ZD-A2-2AT1L
	E	5/3-way valve, mid-position exhausted	24 V DC 110/120 V AC	539187 539174	VSVA-B-P53E-ZD-A2-1T1L VSVA-B-P53E-ZD-A2-2AT1L

1) Code letter within the order code for a valve terminal configuration

Accessories – Ordering data

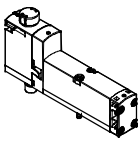
	Code ¹⁾	Description		Part No.	Type
1 Solenoid valve, width 26 mm					
	VC	2x 2/2-way valve, single solenoid, normally closed, pneumatic spring return	24 V DC	561149	VSVA-B-T22C-AZD-A1-1T1L
			110/120 V AC	561150	VSVA-B-T22C-AZD-A1-2AT1L
	WV	2x 2/2-way valve, single solenoid, normally closed, pneumatic spring return, vacuum operation possible at 3 and 5	24 V DC	561153	VSVA-B-T22CV-AZD-A1-1T1L
			110/120 V AC	561154	VSVA-B-T22CV-AZD-A1-2AT1L
	N	2x 3/2-way valve, single solenoid, normally open	24 V DC	539152	VSVA-B-T32U-AZD-A1-1T1L
			110/120 V AC	539139	VSVA-B-T32U-AZD-A1-2AT1L
	K	2x 3/2-way valve, single solenoid, normally closed	24 V DC	539150	VSVA-B-T32C-AZD-A1-1T1L
			110/120 V AC	539137	VSVA-B-T32C-AZD-A1-2AT1L
	H	2x 3/2-way valve, single solenoid, 1x normally open, 1x normally closed	24 V DC	539154	VSVA-B-T32H-AZD-A1-1T1L
			110/120 V AC	539141	VSVA-B-T32H-AZD-A1-2AT1L
	P	2x 3/2-way valve, single solenoid, reverse operation, normally open	24 V DC	539153	VSVA-B-T32F-AZD-A1-1T1L
			110/120 V AC	539140	VSVA-B-T32F-AZD-A1-2AT1L
	Q	2x 3/2-way valve, single solenoid, reverse operation, normally closed	24 V DC	539151	VSVA-B-T32N-AZD-A1-1T1L
			110/120 V AC	539138	VSVA-B-T32N-AZD-A1-2AT1L
	R	2x 3/2-way valve, single solenoid, reverse operation, 1x normally open, 1x normally closed	24 V DC	539155	VSVA-B-T32W-AZD-A1-1T1L
			110/120 V AC	539142	VSVA-B-T32W-AZD-A1-2AT1L
	M	5/2-way valve, single solenoid, pneumatic spring return	24 V DC	539158	VSVA-B-M52-AZD-A1-1T1L
			110/120 V AC	539145	VSVA-B-M52-AZD-A1-2AT1L
	O	5/2-way valve, single solenoid, mechanical spring return	24 V DC	539159	VSVA-B-M52-MZD-A1-1T1L
			110/120 V AC	539146	VSVA-B-M52-MZD-A1-2AT1L
J	5/2-way valve, double solenoid	24 V DC	539156	VSVA-B-B52-ZD-A1-1T1L	
		110/120 V AC	539143	VSVA-B-B52-ZD-A1-2AT1L	
D	5/2-way valve, double solenoid, with dominant signal	24 V DC	539157	VSVA-B-D52-ZD-A1-1T1L	
		110/120 V AC	539144	VSVA-B-D52-ZD-A1-2AT1L	
B	5/3-way solenoid valve, mid-position pressurised	24 V DC	539160	VSVA-B-P53U-ZD-A1-1T1L	
		110/120 V AC	539147	VSVA-B-P53U-ZD-A1-2AT1L	
G	5/3-way solenoid valve, mid-position closed	24 V DC	539162	VSVA-B-P53C-ZD-A1-1T1L	
		110/120 V AC	539149	VSVA-B-P53C-ZD-A1-2AT1L	
E	5/3-way solenoid valve, mid-position exhausted	24 V DC	539161	VSVA-B-P53E-ZD-A1-1T1L	
		110/120 V AC	539148	VSVA-B-P53E-ZD-A1-2AT1L	

1) Code letter within the order code for a valve terminal configuration

Accessories – Ordering data

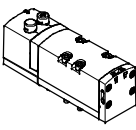
	Code ¹⁾	Description		Part No.	Type
	1 Solenoid valve, width 42 mm				
	VC	2x 2/2-way valve, single solenoid, normally closed, pneumatic spring return	24 V DC	561340	VSVA-B-T22C-AZD-D1-1T1L
			110/120 V AC	561341	VSVA-B-T22C-AZD-D1-2AT1L
	VV	2x 2/2-way valve, single solenoid, normally closed, pneumatic spring return, vacuum operation possible at 3 and 5	24 V DC	561344	VSVA-B-T22CV-AZD-D1-1T1L
			110/120 V AC	561345	VSVA-B-T22CV-AZD-D1-2AT1L
	N	2x 3/2-way valve, single solenoid, normally open	24 V DC	543692	VSVA-B-T32U-AZD-D1-1T1L
			110/120 V AC	543679	VSVA-B-T32U-AZD-D1-2AT1L
	K	2x 3/2-way valve, single solenoid, normally closed	24 V DC	543690	VSVA-B-T32C-AZD-D1-1T1L
			110/120 V AC	543677	VSVA-B-T32C-AZD-D1-2AT1L
	H	2x 3/2-way valve, single solenoid, 1x normally open, 1x normally closed	24 V DC	543694	VSVA-B-T32H-AZD-D1-1T1L
			110/120 V AC	543681	VSVA-B-T32H-AZD-D1-2AT1L
	P	2x 3/2-way valve, single solenoid, reverse operation, normally open	24 V DC	543693	VSVA-B-T32F-AZD-D1-1T1L
			110/120 V AC	543680	VSVA-B-T32F-AZD-D1-2AT1L
	Q	2x 3/2-way valve, single solenoid, reverse operation, normally closed	24 V DC	543691	VSVA-B-T32N-AZD-D1-1T1L
			110/120 V AC	543678	VSVA-B-T32N-AZD-D1-2AT1L
	R	2x 3/2-way valve, single solenoid, reverse operation, 1x normally open, 1x normally closed	24 V DC	543695	VSVA-B-T32W-AZD-D1-1T1L
			110/120 V AC	543682	VSVA-B-T32W-AZD-D1-2AT1L
	M	5/2-way valve, single solenoid, pneumatic spring return	24 V DC	543698	VSVA-B-M52-AZD-D1-1T1L
			110/120 V AC	543685	VSVA-B-M52-AZD-D1-2AT1L
	O	5/2-way valve, single solenoid, mechanical spring return	24 V DC	543699	VSVA-B-M52-MZD-D1-1T1L
			110/120 V AC	543686	VSVA-B-M52-MZD-D1-2AT1L
	J	5/2-way valve, double solenoid	24 V DC	543696	VSVA-B-B52-ZD-D1-1T1L
			110/120 V AC	543683	VSVA-B-B52-ZD-D1-2AT1L
	D	5/2-way valve, double solenoid, with dominant signal	24 V DC	543697	VSVA-B-D52-ZD-D1-1T1L
			110/120 V AC	543684	VSVA-B-D52-ZD-D1-2AT1L
	B	5/3-way solenoid valve, mid-position pressurised	24 V DC	543700	VSVA-B-P53U-ZD-D1-1T1L
			110/120 V AC	543687	VSVA-B-P53U-ZD-D1-2AT1L
	G	5/3-way solenoid valve, mid-position closed	24 V DC	543702	VSVA-B-P53C-ZD-D1-1T1L
110/120 V AC			543689	VSVA-B-P53C-ZD-D1-2AT1L	
E	5/3-way solenoid valve, mid-position exhausted	24 V DC	543701	VSVA-B-P53E-ZD-D1-1T1L	
		110/120 V AC	543688	VSVA-B-P53E-ZD-D1-2AT1L	

1) Code letter within the order code for a valve terminal configuration

Accessories – Ordering data

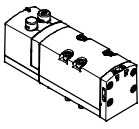
	Code ¹⁾	Description		Part No.	Type
	1 Solenoid valve, width 52 mm				
	VC	2x 2/2-way valve, single solenoid, normally closed, pneumatic spring return	24 V DC	560831	VSVA-B-T22C-AZD-D2-1T1L
			110/120 V AC	560812	VSVA-B-T22C-AZD-D2-2AT1L
	N	2x 3/2-way valve, single solenoid, normally open	24 V DC	560827	VSVA-B-T32U-AZD-D2-1T1L
			110/120 V AC	560808	VSVA-B-T32U-AZD-D2-2AT1L
	K	2x 3/2-way valve, single solenoid, normally closed	24 V DC	560825	VSVA-B-T32C-AZD-D2-1T1L
			110/120 V AC	560806	VSVA-B-T32C-AZD-D2-2AT1L
	H	2x 3/2-way valve, single solenoid, 1x normally open, 1x normally closed	24 V DC	560829	VSVA-B-T32H-AZD-D2-1T1L
			110/120 V AC	560810	VSVA-B-T32H-AZD-D2-2AT1L
	P	2x 3/2-way valve, single solenoid, reverse operation, normally open	24 V DC	560828	VSVA-B-T32F-AZD-D2-1T1L
			110/120 V AC	560809	VSVA-B-T32F-AZD-D2-2AT1L
	Q	2x 3/2-way valve, single solenoid, reverse operation, normally closed	24 V DC	560826	VSVA-B-T32N-AZD-D2-1T1L
			110/120 V AC	560807	VSVA-B-T32N-AZD-D2-2AT1L
	R	2x 3/2-way valve, single solenoid, reverse operation, 1x normally open, 1x normally closed	24 V DC	560830	VSVA-B-T32W-AZD-D2-1T1L
			110/120 V AC	560811	VSVA-B-T32W-AZD-D2-2AT1L
	M	5/2-way valve, single solenoid, pneumatic spring return	24 V DC	560820	VSVA-B-M52-AZD-D2-1T1L
			110/120 V AC	560801	VSVA-B-M52-AZD-D2-2AT1L
	O	5/2-way valve, single solenoid, mechanical spring return	24 V DC	560821	VSVA-B-M52-MZD-D2-1T1L
			110/120 V AC	560802	VSVA-B-M52-MZD-D2-2AT1L
	J	5/2-way valve, double solenoid	110/120 V AC	560799	VSVA-B-B52-ZD-D2-2AT1L
		24 V DC	560818	VSVA-B-B52-ZD-D2-1T1L	
D	5/2-way valve, double solenoid, with dominant signal	24 V DC	560819	VSVA-B-D52-ZD-D2-1T1L	
		110/120 V AC	560800	VSVA-B-D52-ZD-D2-2AT1L	
B	5/3-way solenoid valve, mid-position pressurised	24 V DC	560822	VSVA-B-P53U-ZD-D2-1T1L	
		110/120 V AC	560803	VSVA-B-P53U-ZD-D2-2AT1L	
G	5/3-way solenoid valve, mid-position closed	24 V DC	560824	VSVA-B-P53C-ZD-D2-1T1L	
		110/120 V AC	560805	VSVA-B-P53C-ZD-D2-2AT1L	
E	5/3-way solenoid valve, mid-position exhausted	24 V DC	560823	VSVA-B-P53E-ZD-D2-1T1L	
		110/120 V AC	560804	VSVA-B-P53E-ZD-D2-2AT1L	

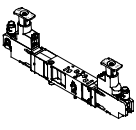
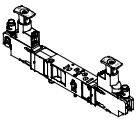
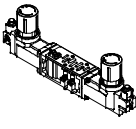
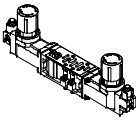

1) Code letter within the order code for a valve terminal configuration

Accessories – Ordering data

	Code ¹⁾		Description	Part No.	Type
2) Regulator plate					
	ZA	Width 18 mm	For port 1, 0.5...10 bar	540153	VABF-S4-2-R1C2-C-10
	ZF		For port 1, 0.5...6 bar	540151	VABF-S4-2-R1C2-C-6
	ZC		For port 2, 2...10 bar	540161	VABF-S4-2-R2C2-C-10
	ZH		For port 2, 2...6 bar	540159	VABF-S4-2-R2C2-C-6
	ZB		For port 4, 2...10 bar	540157	VABF-S4-2-R3C2-C-10
	ZG		For port 4, 2...6 bar	540155	VABF-S4-2-R3C2-C-6
	ZD		For ports 2 and 4, 2...10 bar	540165	VABF-S4-2-R4C2-C-10
	ZI		For ports 2 and 4, 2...6 bar	540163	VABF-S4-2-R4C2-C-6
	ZE		For ports 2 and 4, reversible, 0.5...10 bar	540169	VABF-S4-2-R5C2-C-10
	ZJ		For ports 2 and 4, reversible, 0.5...6 bar	540167	VABF-S4-2-R5C2-C-6
	ZL		For port 2, reversible, 0.5...10 bar	546252	VABF-S4-2-R6C2-C-10
	ZN		For port 2, reversible, 0.5...6 bar	546248	VABF-S4-2-R6C2-C-6
	ZK		For port 4, reversible, 0.5...10 bar	546254	VABF-S4-2-R7C2-C-10
	ZM		For port 4, reversible, 0.5...6 bar	546250	VABF-S4-2-R7C2-C-6
	ZA	Width 26 mm	For port 1, 0.5...10 bar	540154	VABF-S4-1-R1C2-C-10
	ZF		For port 1, 0.5...6 bar	540152	VABF-S4-1-R1C2-C-6
	ZC		For port 2, 2...10 bar	540162	VABF-S4-1-R2C2-C-10
	ZH		For port 2, 2...6 bar	540160	VABF-S4-1-R2C2-C-6
	ZB		For port 4, 2...10 bar	540158	VABF-S4-1-R3C2-C-10
	ZG		For port 4, 2...6 bar	540156	VABF-S4-1-R3C2-C-6
	ZD		For ports 2 and 4, 2...10 bar	540166	VABF-S4-1-R4C2-C-10
	ZI		For ports 2 and 4, 2...6 bar	540164	VABF-S4-1-R4C2-C-6
	ZE		For ports 2 and 4, reversible, 0.5...10 bar	540170	VABF-S4-1-R5C2-C-10
	ZJ		For ports 2 and 4, reversible, 0.5...6 bar	540168	VABF-S4-1-R5C2-C-6
	ZL		For port 2, reversible, 0.5...10 bar	546251	VABF-S4-1-R6C2-C-10
	ZN		For port 2, reversible, 0.5...6 bar	546247	VABF-S4-1-R6C2-C-6
	ZK		For port 4, reversible, 0.5...10 bar	546253	VABF-S4-1-R7C2-C-10
	ZM		For port 4, reversible, 0.5...6 bar	546249	VABF-S4-1-R7C2-C-6
	ZA	Width 42 mm	For port 1, 0.5...10 bar	546084	VABF-S2-1-R1C2-C-10
	ZF		For port 1, 0.5...6 bar	546083	VABF-S2-1-R1C2-C-6
	ZC		For port 2, 0.5...10 bar	546088	VABF-S2-1-R2C2-C-10
	ZH		For port 2, 0.5...6 bar	546087	VABF-S2-1-R2C2-C-6
	ZB		For port 4, 0.5...10 bar	546086	VABF-S2-1-R3C2-C-10
	ZG		For port 4, 0.5...6 bar	546085	VABF-S2-1-R3C2-C-6
	ZD		For ports 2 and 4, 0.5...10 bar	546090	VABF-S2-1-R4C2-C-10
	ZI		For ports 2 and 4, 0.5...6 bar	546089	VABF-S2-1-R4C2-C-6
	ZE		For ports 2 and 4, reversible, 0.5...10 bar	546092	VABF-S2-1-R5C2-C-10
	ZJ		For ports 2 and 4, reversible, 0.5...6 bar	546091	VABF-S2-1-R5C2-C-6
	ZL		For port 2, reversible, 0.5...10 bar	546832	VABF-S2-1-R6C2-C-10
	ZN		For port 2, reversible, 0.5...6 bar	546831	VABF-S2-1-R6C2-C-6
	ZK		For port 4, reversible, 0.5...10 bar	546834	VABF-S2-1-R7C2-C-10
	ZM		For port 4, reversible, 0.5...6 bar	546833	VABF-S2-1-R7C2-C-6
	ZA	Width 52 mm	For port 1, 0.5...10 bar	555772	VABF-S2-2-R1C2-C-10
	ZF		For port 1, 0.5...6 bar	555771	VABF-S2-2-R1C2-C-6
	ZC		For port 2, 0.5...10 bar	555774	VABF-S2-2-R2C2-C-10
	ZH		For port 2, 0.5...6 bar	555773	VABF-S2-2-R2C2-C-6
	ZB		For port 4, 0.5...10 bar	555776	VABF-S2-2-R3C2-C-10
	ZG		For port 4, 0.5...6 bar	555775	VABF-S2-2-R3C2-C-6
	ZD		For ports 2 and 4, 0.5...10 bar	555778	VABF-S2-2-R4C2-C-10
	ZI		For ports 2 and 4, 0.5...6 bar	555777	VABF-S2-2-R4C2-C-6
	ZE		For ports 2 and 4, reversible, 0.5...10 bar	555780	VABF-S2-2-R5C2-C-10
	ZJ		For ports 2 and 4, reversible, 0.5...6 bar	555779	VABF-S2-2-R5C2-C-6
	ZL		For port 2, reversible, 0.5...10 bar	555782	VABF-S2-2-R6C2-C-10
	ZN		For port 2, reversible, 0.5...6 bar	555781	VABF-S2-2-R6C2-C-6
	ZK		For port 4, reversible, 0.5...10 bar	555784	VABF-S2-2-R7C2-C-10
	ZM		For port 4, reversible, 0.5...6 bar	555783	VABF-S2-2-R7C2-C-6



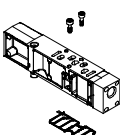
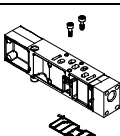
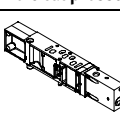
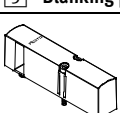
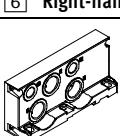
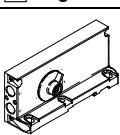

1) Code letter within the order code for a valve terminal configuration

Accessories – Ordering data

	Code ¹⁾	Description		Part No.	Type
3 Accessories for regulator plate, pressure gauge for widths 18 mm and 26 mm					
Technical data online: → pagn					
	U	6 bar, for regulator plate code ZF, ZG, ZH, ZI, ZJ, ZM, ZN	Widths 18 mm and 26 mm	543488	PAGN-26-10-P10
			Widths 42 mm and 52 mm	548009	PAGN-40-10-P10
	T	10 bar, for regulator plate code ZA, ZB, ZC, ZD, ZE, ZK, ZL	Widths 18 mm and 26 mm	543487	PAGN-26-16-P10
			Widths 42 mm and 52 mm	548010	PAGN-40-16-P10
Cartridge fitting					
Technical data online: → qsp					
	-	For thread G $\frac{1}{8}$ (allows products with threaded connection G $\frac{1}{8}$ to be attached to the cartridge fitting connection)		565811	QSP10-G $\frac{1}{8}$
	-	For tubing O.D. 4 mm		172972	QSP10-4
4 Additional vertical stacking modules, flow control plate					
	X	Controls the flow of exhaust air downstream of the valve to ducts 3 and 5	Width 18 mm	540176	VABF-S4-2-F1B1-C
			Width 26 mm	540175	VABF-S4-1-F1B1-C
			Width 42 mm	546095	VABF-S2-1-F1B1-C
			Width 52 mm	555789	VABF-S2-2-F1B1-C
Vertical supply plate					
	ZU	Compressed air supply, duct 1	Width 18 mm, connection G $\frac{1}{8}$	540173	VABF-S4-2-P1A3-G18
			Width 26 mm, connection G $\frac{1}{4}$	540171	VABF-S4-1-P1A3-G14
			Width 42 mm, connection G $\frac{3}{8}$	546093	VABF-S2-1-P1A3-G38
			Width 52 mm, connection G $\frac{1}{2}$	555786	VABF-S2-2-P1A3-G12
	ZV	Compressed air supply, duct 1 and 14	Width 18 mm, connection G $\frac{1}{8}$	8000693	VABF-S4-2-P1A14-G18
			Width 26 mm, connection G $\frac{1}{4}$	8000689	VABF-S4-1-P1A14-G14
			Width 42 mm, connection G $\frac{3}{8}$	8000536	VABF-S2-1-P1A14-G38
			Width 52 mm, connection G $\frac{1}{2}$	8000549	VABF-S2-2-P1A14-G12
Vertical pressure shut-off plate					
	ZT	For shutting off the operating pressure at the valve position	Width 18 mm	542884	VABF-S4-2-L1D1-C
			Width 26 mm	542885	VABF-S4-1-L1D1-C
			Width 42 mm	546096	VABF-S2-1-L1D1-C
			Width 52 mm	555791	VABF-S2-2-L1D1-C
5 Blanking plate for vacant position					
	L	For sealing vacant valve positions	Width 18 mm	539213	VABB-S4-2-WT
			Width 26 mm	539212	VABB-S4-1-WT
			Width 42 mm	543186	VABB-S2-1-WT
			Width 52 mm	560845	VABB-S2-2-WT
6 Right-hand end plate with ports for supply air/exhaust air					
	V	Internal pilot air supply, G $\frac{1}{2}$		539234	VABE-S6-1R-G12
	V1	Internal pilot air supply, G $\frac{3}{4}$		560837	VABE-S6-2R-G34
	X	External pilot air supply, G $\frac{1}{2}$		539236	VABE-S6-1RZ-G12
	X1	External pilot air supply, G $\frac{3}{4}$		560839	VABE-S6-2RZ-G34
7 Right-hand end plate with pilot air selector					
	Y	Internal pilot air supply		539238	VABE-S6-1RZ-G-B1
	U	Internal pilot air supply, ducted pilot exhaust air			
	Z	External pilot air supply			
	W	External pilot air supply, ducted pilot exhaust air			

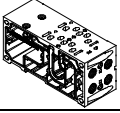
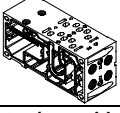
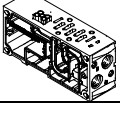

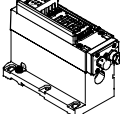
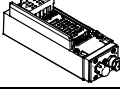

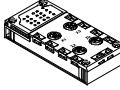
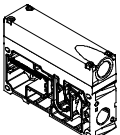
1) Code letter within the order code for a valve terminal configuration

Accessories – Ordering data

	Code ¹⁾	Description		Part No.	Type
8] Manifold sub-base, 2 valve positions					
	A	4 addresses, for double solenoid valves	Width 18 mm	539224	VABV-S4-2S-G18-2T2
	B		Width 26 mm	539220	VABV-S4-1S-G14-2T2
	E	2 addresses, for single solenoid valves	Width 18 mm	539226	VABV-S4-2S-G18-2T1
	F		Width 26 mm	539222	VABV-S4-1S-G14-2T1
2 valve positions, optimised for flow rate (VTSA-F)					
	A	4 addresses, for double solenoid valves	Width 18 mm	546215	VABV-S4-2HS-G18-2T2
	B		Width 26 mm	546211	VABV-S4-1HS-G14-2T2
	E	2 addresses, for single solenoid valves	Width 18 mm	546214	VABV-S4-2HS-G18-2T1
	F		Width 26 mm	546210	VABV-S4-1HS-G14-2T1
1 valve position					
	C	2 addresses, for double solenoid valves	Width 42 mm	542458	VABV-S2-1S-G38-T2
	D		Width 52 mm	560841	VABV-S2-2S-G12-T2
	G	1 address, for single solenoid valves	Width 42 mm	542459	VABV-S2-1S-G38-T1
	H		Width 52 mm	560842	VABV-S2-2S-G12-T1
9] Duct separation					
	S	Duct 1, 3 and 5 separated		539228	VABD-S6-1-P3-C
	T	Duct 1 separated		539227	VABD-S6-1-P1-C
	R	Duct 3 and 5 separated		539229	VABD-S6-1-P2-C
10] Electrical interface for AS-interface					
	-	4 inputs/4 outputs		549042	VABE-S6-1LF-C-A4-E
	-	8 inputs/8 outputs		549043	VABE-S6-1LF-C-A8-E
11] AS-interface module					
	-	4 inputs/4 outputs		549044	VAEM-S6-S-FAS-4-4E
	-	8 inputs/8 outputs		549045	VAEM-S6-S-FAS-8-8E
12] Cover cap for manual override					
	N	Non-detenting	10 pieces	541010	VAMC-S6-CH
	V	Covered	10 pieces	541011	VAMC-S6-CS
13] Inscription label					
	B	Clip-on for valve cap	5 pieces	540888	ASCF-T-S6
	T	For manifold blocks	5 pieces	540889	ASCF-M-S6
14] Manifold block for AS-interface					
	X	4x M12, 5-pin, double, socket		★ 195704	CPX-AB-4-M12x2-5POL
	GW	4x M12, 5-pin, socket, metal thread		541254	CPX-AB-4-M12x2-5POL-R
	R	8x M8, 3-pin, socket		★ 195706	CPX-AB-8-M8-3POL
	J	8x spring-loaded terminal, 4 pin		★ 195708	CPX-AB-8-KL-4POL
	H	4x quick connection, 4-pin, socket		525636	CPX-AB-4-HAR-4POL
	B	Sub-D, 25-pin, socket		525676	CPX-AB-1-SUB-BU-25POL
15] Supply plate					
	L	With exhaust plate, 3/5 common, G1/2		539231	VABF-S6-1-P1A7-G12
	K	With exhaust port cover, 3/5 separated, G1/2		539230	VABF-S6-1-P1A6-G12

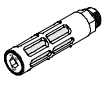

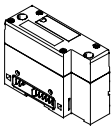
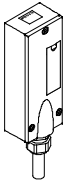
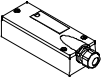
1) Code letter within the order code for a valve terminal configuration

Accessories – Ordering data

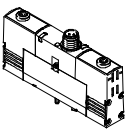
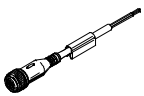

	Code ¹⁾	Description		Part No.	Type		
16 Silencer Technical data → 994							
	-	For thread G $\frac{1}{8}$	★	6841	U- $\frac{1}{8}$ -B		
	-	For thread G $\frac{1}{4}$	★	2316	U- $\frac{1}{4}$		
	-	For thread G $\frac{1}{2}$	★	6844	U- $\frac{1}{2}$ -B		
17 Blanking plug Technical data online: → b-1							
		Thread G $\frac{1}{8}$	10 pieces	3568	B- $\frac{1}{8}$		
		Thread G $\frac{1}{4}$	10 pieces	3569	B- $\frac{1}{4}$		
18 Push-in fitting Technical data → 908							
		Connecting thread G $\frac{1}{8}$	For tubing O.D. 6 mm	10 pieces	★	186096	QS-G $\frac{1}{8}$ -6
			For tubing O.D. 8 mm	10 pieces	★	186098	QS-G $\frac{1}{8}$ -8
		Connecting thread G $\frac{1}{4}$	For tubing O.D. 8 mm	10 pieces	★	186099	QS-G $\frac{1}{4}$ -8
			For tubing O.D. 10 mm	10 pieces	★	186101	QS-G $\frac{1}{4}$ -10
		Connecting thread G $\frac{1}{2}$	For tubing O.D. 12 mm	1 piece	★	186104	QS-G $\frac{1}{2}$ -12
			For tubing O.D. 16 mm	1 piece	★	186105	QS-G $\frac{1}{2}$ -16
		Connecting thread G $\frac{3}{8}$	For tubing O.D. 10 mm	10 pieces	★	186102	QS-G $\frac{3}{8}$ -10
			For tubing O.D. 12 mm	10 pieces	★	186114	QS-G $\frac{3}{8}$ -12-l
19 Pneumatic interface							
		For CPX in plastic design		543416	VABA-S6-1-X1		
		For CPX in metal design		550663	VABA-S6-1-X2		
		For CPX in metal design with diagnostic function		573613	VABA-S6-1-X2-D		
20 Multi-pin plug connection with connecting cable Technical data online: → nebv							
	GA	Polyurethane, IP65	For max. 8 solenoid coils, 10-pin	2.5 m	539240	NEBV-S1W37-E-2,5-LE10	
	GB			5 m	539241	NEBV-S1W37-E-5-LE10	
	GC			10 m	539242	NEBV-S1W37-E-10-LE10	
	GD		For max. 22 solenoid coils, 26-pin	2.5 m	539243	NEBV-S1W37-E-2,5-LE26	
	GE			5 m	539244	NEBV-S1W37-E-5-LE26	
	GF			10 m	539245	NEBV-S1W37-E-10-LE26	
	GG		For max. 32 solenoid coils, 37-pin	2.5 m	539246	NEBV-S1W37-K-2,5-LE37	
	GH			5 m	539247	NEBV-S1W37-K-5-LE37	
	GI			10 m	539248	NEBV-S1W37-K-10-LE37	
	GK	Polyvinyl chloride, IP65	For max. 8 solenoid coils, 10-pin	2.5 m	543271	NEBV-S1W37-KM-2,5-LE10	
	GL			5 m	543272	NEBV-S1W37-KM-5-LE10	
	GM			10 m	543273	NEBV-S1W37-KM-10-LE10	
	GN		For max. 22 solenoid coils, 27-pin	2.5 m	543274	NEBV-S1W37-KM-2,5-LE27	
	GO			5 m	543275	NEBV-S1W37-KM-5-LE27	
	GP			10 m	543276	NEBV-S1W37-KM-10-LE27	
	GQ		For max. 32 solenoid coils, 37-pin	2.5 m	543277	NEBV-S1W37-KM-2,5-LE37	
GR	5 m			543278	NEBV-S1W37-KM-5-LE37		
GS	10 m			543279	NEBV-S1W37-KM-10-LE37		
20 Cover for self-assembly							
	-	Cover for multi-pin plug connection		545974	NECV-S1W37		
24 Sealing cap for electrical interlinking module							
	-	Size 18 mm and 26 mm	10 pieces	547713	VABD-S4-E-C		

1) Code letter within the order code for a valve terminal configuration

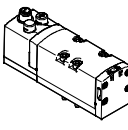
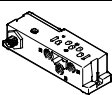
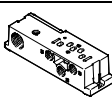
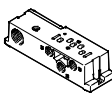
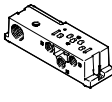
Accessories – Ordering data

Description		Part No.	Type	
25 Solenoid valve to ISO15407-1		Technical data online: → vsva		
	Width 18 mm	2x 3/2-way solenoid valve, normally closed	546764 VSVA-B-T32C-AH-A2-1R5L	
		5/2-way valve, single solenoid	★ 546768 VSVA-B-M52-MH-A2-1R5L	
		5/2-way valve, double solenoid	★ 546769 VSVA-B-B52-H-A2-1R5L	
		5/3-way solenoid valve, normally closed	546771 VSVA-B-P53C-H-A2-1R5L	
	Width 26 mm	2x 3/2-way solenoid valve, normally closed	534552 VSVA-B-T32C-AH-A1-1R5L	
		5/2-way valve, single solenoid	★ 534556 VSVA-B-M52-MH-A1-1R5L	
		5/2-way valve, double solenoid	★ 534557 VSVA-B-B52-H-A1-1R5L	
		5/3-way solenoid valve, normally closed	534559 VSVA-B-P53C-H-A1-1R5L	
26 Connecting cable M12		Technical data → 949		
	Straight socket	2.5 m	550326 NEBU-M12G5-K-2,5-LE4	
		5 m	541328 NEBU-M12G5-K-5-LE4	
	Angled socket	5 m	541329 NEBU-M12W5-K-5-LE4	
27 Seal, 2 pieces, sizes 42 mm and 52 mm				
	For valves with individual connection	571343	VABD-S2-1-S-C	
28 Solenoid valve to ISO5599-1		Technical data → 549		
	Width 42 mm	2x 3/2-way solenoid valve, normally closed	561359 VSVA-B-T32C-AD-D1-1R5L	
		5/2-way valve, single solenoid	★ 561363 VSVA-B-M52-MD-D1-1R5L	
		5/2-way valve, double solenoid	★ 561364 VSVA-B-B52-D-D1-1R5L	
		5/3-way solenoid valve, normally closed	561366 VSVA-B-P53C-D-D1-1R5L	
	Width 52 mm	2x 3/2-way solenoid valve, normally closed	566990 VSVA-B-T32C-AD-D2-1R5L	
		5/2-way valve, single solenoid	566994 VSVA-B-M52-MD-D2-1R5L	
		5/2-way valve, double solenoid	566995 VSVA-B-B52-D-D2-1R5L	
		5/3-way solenoid valve, normally closed	566997 VSVA-B-P53C-D-D2-1R5L	
29 Individual sub-base, electrical connection with plug connector M12				
	Internal pilot air supply	Connections G3/8	Width 18 mm	541070 VABS-S4-2S-G18-B-R3
		Connections G3/4	Width 26 mm	541069 VABS-S4-1S-G14-B-R3
		Connections G3/8	Width 42 mm	546104 VABS-S2-1S-G38-B-R3
		Connections G1/2	Width 52 mm	555645 VABS-S2-2S-G12-B-R3
	External pilot air supply	Connections G3/8	Width 18 mm	541064 VABS-S4-2S-G18-R3
		Connections G3/4	Width 26 mm	541063 VABS-S4-1S-G14-R3
		Connections G3/8	Width 42 mm	546101 VABS-S2-1S-G38-R3
		Connections G1/2	Width 52 mm	555640 VABS-S2-2S-G12-R3
Electrical connection with cable terminals				
	Internal pilot air supply	Connections G3/8	Width 18 mm	541067 VABS-S4-2S-G18-B-K2
		Connections G3/4	Width 26 mm	541065 VABS-S4-1S-G14-B-K2
	External pilot air supply	Connections G3/8	Width 18 mm	539723 VABS-S4-2S-G18-K2
		Connections G3/4	Width 26 mm	539725 VABS-S4-1S-G14-K2
Electrical connection with spring-loaded terminal				
	Internal pilot air supply	Connections G3/8	Width 42 mm	546762 VABS-S2-1S-G38-B-C1
		Connections G1/2	Width 52 mm	555643 VABS-S2-2S-G12-B-C1
	External pilot air supply	Connections G3/8	Width 42 mm	546760 VABS-S2-1S-G38-C1
		Connections G1/2	Width 52 mm	555638 VABS-S2-2S-G12-C1
Electrical connection for self-assembly				
	Internal pilot air supply	Connections G3/8	Width 42 mm	546102 VABS-S2-1S-G38-B-K1
		Connections G1/2	Width 52 mm	555641 VABS-S2-2S-G12-B-K1
	External pilot air supply	Connections G3/8	Width 42 mm	546099 VABS-S2-1S-G38-K1
		Connections G1/2	Width 52 mm	555636 VABS-S2-2S-G12-K1

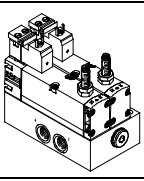
Accessories – Ordering data

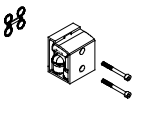
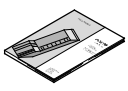
	Code ¹⁾	Description	Part No.	Type
		Control block, individual connection variant	Technical data online: → vofa	
	-	PNP output	★ 569819	VOFA-L26-T52-M-G14-1C1-APP
	-	NPN output	569820	VOFA-L26-T52-M-G14-1C1-ANP
Wall mounting				
	U	Mounting bracket, 5 pieces	539214	VAME-S6-10-W
	-	Mounting bracket	567038	VAME-S6-W-M46
90° connection plate				
	P	Width 18 mm, connecting thread G1/8	539719	VABF-S4-2-A2G2-G18
		Width 26 mm, connecting thread G1/4	539721	VABF-S4-1-A2G2-G14
		Width 42 mm, connecting thread G3/8	546097	VABF-S2-1-A1G2-G38
		Width 52 mm, connecting thread G1/2	555702	VABF-S2-2-A1G2-G12
User documentation				
	D	German	538922	P.BE-VTSA-44-DE
	E	English	538923	P.BE-VTSA-44-EN
	S	Spanish	538924	P.BE-VTSA-44-ES
	F	French	538925	P.BE-VTSA-44-FR
	I	Italian	538926	P.BE-VTSA-44-IT
	V	Swedish	538927	P.BE-VTSA-44-SV

1) Code letter within the order code for a valve terminal configuration

Valve terminals VTUG with multi-pin plug and fieldbus connection

FESTO

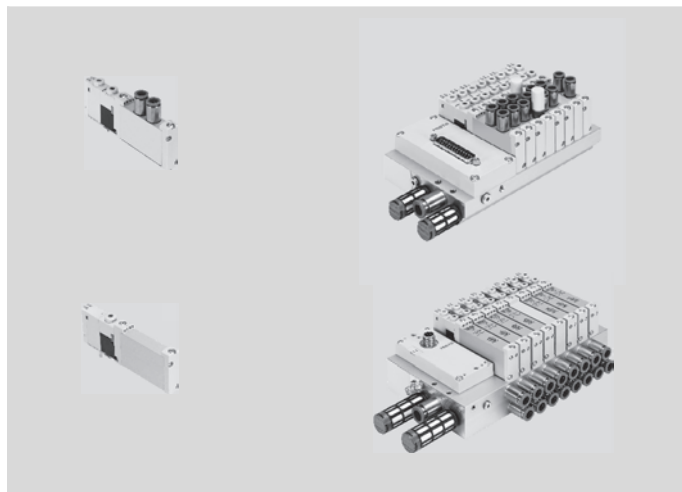

- Variable multi-pin plug connection using Sub-D or flat cable
- I-Port interface for fieldbus nodes (CTEU)
- IO-Link mode for direct connection to a higher-level IO-Link master
- Width 10 mm and 14 mm
- Sub-D variant and fieldbus connection rated to IP67
- Piston spool valves, up to 24 valve positions
- ★ Quick ordering of basic designs → 652, 654

→ www.festo.com/catalogue/vtug

Product range overview

Type	Design	Working port	Width [mm]	Valve functions and flow rate [l/min]							→ Page/online
				T32-A	T32-M	M52-A	M52-M	M52-R	B52	P53	
VUVG-S...T1	Semi in-line valve	M5, front	10	150	130	–	230	230	230	210	647
		M7, front	10	160	140	–	290	330	330	280	647
		G $\frac{1}{8}$, front	14	610	520	620	620	–	630	590	649
VUVG-B...T1	Sub-base valve	M5, front	10	150	130	–	220	220	220	200	651
		M7, front	10	160	140	–	240	270	270	250	651
		M7, underneath	10	160	140	–	260	300	300	260	651
		G $\frac{1}{8}$, front	14	490	440	500	500	–	510	470	653
		G $\frac{1}{8}$, underneath	14	530	470	550	550	–	560	510	653

Valve functions:

- T32C-A 2x3/2-way valve, normally closed, pneumatic spring
 T32U-A 2x3/2-way valve, normally open, pneumatic spring
 T32H-A 2x3/2-way valve, 1x normally closed, 1x normally open, pneumatic spring
 T32C-M 2x3/2-way valve, normally closed, mechanical spring
 T32U-M 2x3/2-way valve, normally open, mechanical spring
 T32H-M 2x3/2-way valve, 1x normally closed, 1x normally open, mechanical spring
 M52-A 5/2-way valve, single solenoid, pneumatic spring (width 14)
 M52-M 5/2-way valve, single solenoid, mechanical spring
 M52-R 5/2-way valve, single solenoid, pneumatic/mechanical spring (width 10)
 B52 5/2-way valve, double solenoid
 P53C 5/3-way valve, mid-position closed
 P53U 5/3-way valve, mid-position pressurised
 P53E 5/3-way valve, mid-position exhausted

Valve terminals VTUG with multi-pin plug and fieldbus connection

Key features

Innovative

- I-Port interface for fieldbus nodes (CTEU)
- IO-Link mode for direct connection to a higher-level IO-Link master
- Variable multi-pin plug connection using Sub-D or flat cable
- Reversible piston spool valves, up to 24 valve positions
- Reduced power consumption
- Excellent price/performance ratio

Versatile

- Choice of quick plug connectors
- Multiple pressure zones possible
- Sub-D variant and fieldbus connection rated to IP67
- Internal or external pilot air with the same manifold rail possible through the use of blanking plugs
- Sub-base valves with working ports underneath for installation in control cabinets

Reliable

- Sturdy and durable metal components
 - Valves
 - Manifold rails
- Fast troubleshooting thanks to LED display
- Choice of manual override: non-detenting, detenting or covered

Easy to mount

- Easy mounting thanks to captive screws and seal
- Connection technology easy to change via the connecting plate
- Inscription label holder for labelling

Sub-base and semi in-line valves

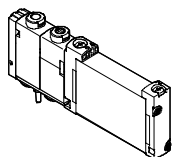

Sub-base valve
VUVG-B...1T1

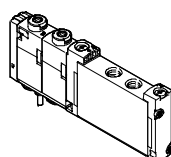

VUVG-S...1T1
Semi in-line valve

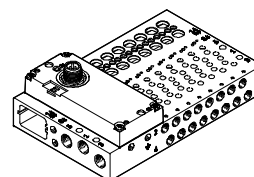

Valve terminal VTUG with variable electrical connection

Overview

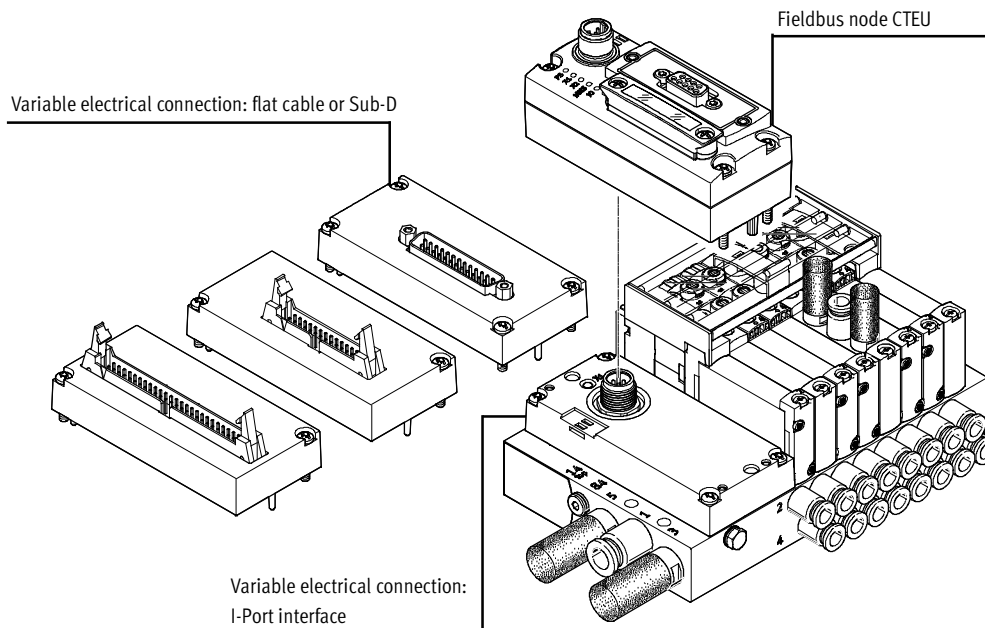

Equipment options

Valve functions

- 2x3/2-way, 5/2-way, 5/3-way valves
- Piston spool valves, up to 24 valve positions
- IO-Link mode for direct connection to a higher-level IO-Link master
- Fieldbus node CTEU
- Variable multi-pin plug connection using Sub-D or flat cable

Valve terminals VTUG with multi-pin plug and fieldbus connection

FESTO

Key features

Basic valves VUVG

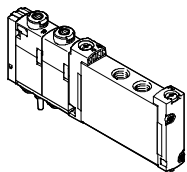

- Width 10 and 14 mm
- Semi in-line valves
- Sub-base valves
- 2x3/2-way, 5/2-way and 5/3-way valves

Electrical connection

Multi-pin plug connection

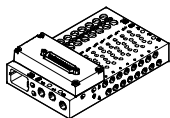

The signals are transmitted from the controller to the valve terminal via a pre-assembled or self-assembled multi-wire cable to the multi-pin plug connection,

which substantially reduces installation time. The valve terminal can be equipped with max. 48 solenoid coils.

Versions:

- Sub-D connection
- Flat cable

I-Port interface

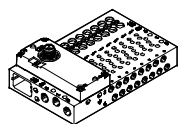

Festo-specific interface as a basis for fieldbus nodes (CTEU) or in IO-Link mode for direct connection to a higher-level IO-Link master.

Transmission of communication data and the power supply takes place via an M12 plug on the terminal.

Connection options:

- As an I-Port interface for fieldbus nodes (CTEU)
- In IO-Link mode for direct connection to an IO-Link master

Manifold rails

for semi in-line valves

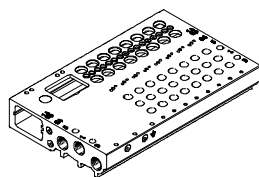

- For semi in-line valves, M5, M7, width 10 mm and G1/8, width 14 mm
- For 2x3/2-way, 5/2-way and 5/3-way valves
- 4 to 24 valve positions with electrical interlinking
- The semi in-line valves are always supplied with external pilot air. The pilot air is set via the manifold rail. A short and a long blanking plug are included with the manifold rail for this purpose.

for sub-base valves

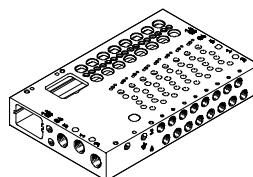

- For sub-base valves M5/M7, width 10 mm and G1/8, width 14 mm
- For 2x3/2-way, 5/2-way and 5/3-way valves
- 4 to 24 valve positions with electrical interlinking
- The sub-base valves are always supplied with external pilot air. The pilot air is set via the manifold rail. A short and a long blanking plug are included with the manifold rail for this purpose.

Valve terminals VTUG with multi-pin plug and fieldbus connection

Key features

- Communication with higher-level controller via fieldbus
- Use the fieldbus node CTEU compatible with the fieldbus protocol
- Up to 64 inputs/outputs (solenoid coils), depending on the valve terminal
- No preprocessing

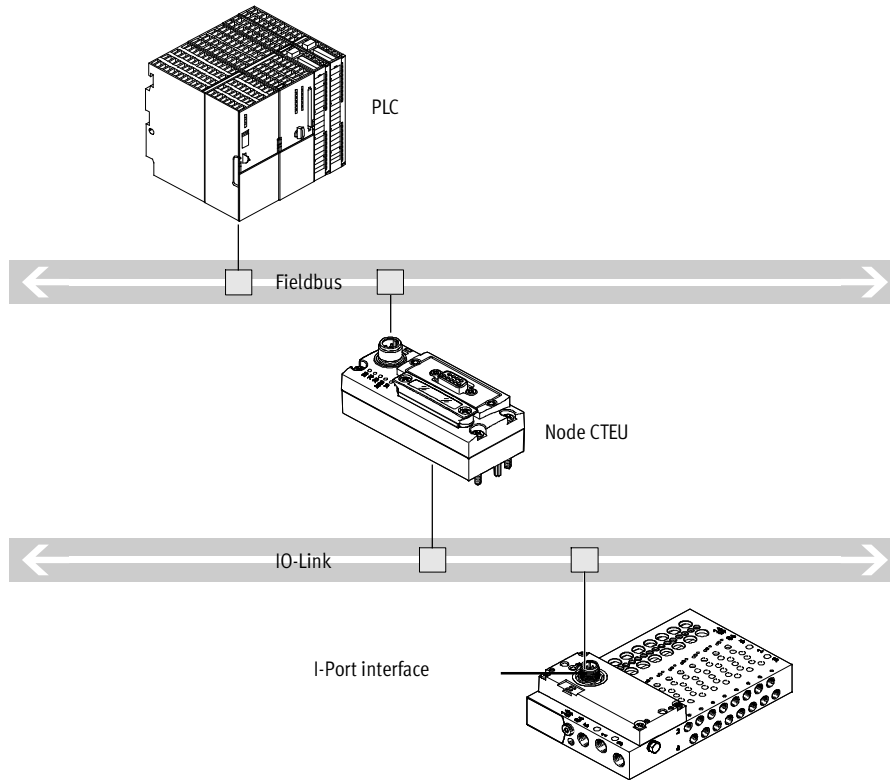

System overview – IO-Link



Valve terminals VTUG with multi-pin plug and fieldbus connection

FESTO

Technical data – Semi in-line valve M5/M7

-  Width 10 mm
-  Flow rate
130 ... 330 l/min
-  Operating voltage
24 V DC



Technical data	Download CAD data → www.festo.com											
	T32-A			T32-M			M52-R	B52	M52-M	P53		
Valve function	C ¹⁾	U ²⁾	H ⁴⁾	C ¹⁾	U ²⁾	H ⁴⁾	–	–	–	C ¹⁾	U ²⁾	E ³⁾
Normal position							–	–	–			
Pneumatic spring reset method	Yes			No			Yes ⁵⁾	–	No			–
Mechanical spring reset method	No			Yes			Yes ⁵⁾	–	Yes			–
Stable position	Monostable							Bistable	Monostable			
Port 1, 3, 5	On manifold rail											
Port 2, 4	VUVG-S10-...-M5						M5					
Port 2, 4	VUVG-S10-...-M7						M7					
Port 12, 14	On manifold rail											
Standard nominal flow rate M5	[l/min]			150	130	230				210		
Standard nominal flow rate M7	[l/min]			160	140	330		290	280			
Flow rate on manifold rail M5	[l/min]			150	130	230				210		
Flow rate on manifold rail M7	[l/min]			160	140	330		290	280			
Vacuum operation at port 1	No			Only with external pilot air supply								
Design	Piston spool valve											
Type of mounting	On manifold rail											
Electrical connection	Via connecting plate											
Manual override	Choice of non-detenting/detenting (standard), non-detenting or covered											

- 1) C = Normally closed
- 2) U = Normally open
- 3) E = Normally exhausted
- 4) H=2x 3/2-way valve in one housing with 1x normally closed and 1x normally open
- 5) Combined reset method

Operating conditions		T32-A ⁶⁾	T32-M ⁷⁾	M52-R ⁸⁾	B52	M52-M ⁷⁾	P53
Valve function		Compressed air to ISO 8573-1:2010 [7:4:4]					
Operating pressure	Internal	1.5 ... 8	2 ... 8	2.5 ... 8	1.5 ... 8	3 ... 8	
	External	1.5 ... 10	–0.9 ... 10			–0.9 ... 8	–0.9 ... 10
Pilot pressure ⁹⁾		1.5 ... 8	2 ... 8	2.5 ... 8	1.5 ... 8	3 ... 8	
Ambient temperature	[°C]	–5 ... +60					
Temperature of medium	[°C]	–5 ... +60					

- 6) Pneumatic spring
- 7) Mechanical spring
- 8) Pneumatic/mechanical spring
- 9) Minimum pilot pressure 50% of operating pressure

Materials	
Housing	Wrought aluminium alloy
Seals	HNBR, NBR

Valve terminals VTUG with multi-pin plug and fieldbus connection

Order code

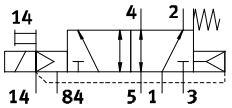
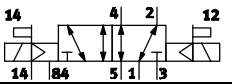
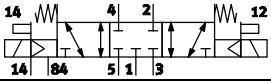
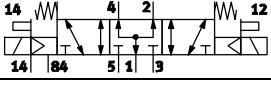
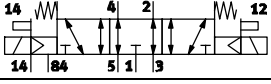
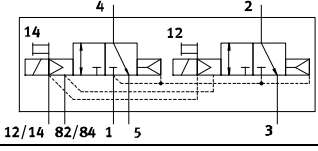
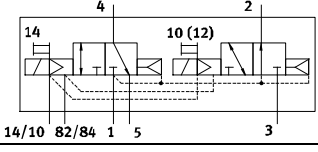
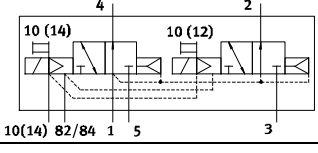
VUVG	-	10	-	-
Valve design				
Semi in-line valve	S			
Width				
10 mm	10			
Valve function				
				M52
				B52
				P53C
				P53U
				P53E
				T32C
				T32H
				T32U



9

		Display
		L LED
		Electrical connection
		T1 Plug-in
		Nominal operating voltage
		1 24 V DC
Pneumatic connection		
M5	M5	
M7	M7	
Q3	Push-in connector 3 mm	
Q4	Push-in connector 4 mm	
Q4H	Push-in connector 4 mm/M7	
Q6	Push-in connector 6 mm	
Q6H	Push-in connector 6 mm/M7	
T14	Push-in connector 1/4"	
T14H	Push-in connector 1/4", M7	
T18	Push-in connector 1/8"	
T316	Push-in connector 3/16"	
T316H	Push-in connector 3/16", M7	
T532	Push-in connector 5/32"	
Manual override		
H	Non-detenting	
S	Covered	
T	Non-detenting, detenting	
Pilot air		
Z	External	
Reset method		
A	Pneumatic spring for 2x3/2-way	
M	Mechanical spring for M52 and 2x3/2-way	
R	Pneu./mech. spring for M52	
-	With B52 and P53	

Valve terminals VTUG with multi-pin plug and fieldbus connection

FESTO

Technical data – Semi in-line valve G $\frac{1}{8}$

-  Width 14 mm
-  Flow rate
520 ... 630 l/min
-  Operating voltage
24 V DC



Technical data	Download CAD data → www.festo.com						
	T32-A	T32-M	M52-A	B52	M52-M	P53	
Valve function	C ¹⁾ U ²⁾ H ⁴⁾	C ¹⁾ U ²⁾ H ⁴⁾	–	–	–	C ¹⁾ U ²⁾ E ³⁾	
Normal position	C ¹⁾ U ²⁾ H ⁴⁾	C ¹⁾ U ²⁾ H ⁴⁾	–	–	–	C ¹⁾ U ²⁾ E ³⁾	
Pneumatic spring reset method	Yes	No	Yes	–	No	–	
Mechanical spring reset method	No	Yes	No	–	Yes	–	
Stable position	Monostable			Bistable	Monostable		
Port 1, 3, 5	On manifold rail						
Port 2, 4	G $\frac{1}{8}$						
Port 12, 14	On manifold rail						
Standard nominal flow rate G $\frac{1}{8}$	[l/min]	610	520	620	630	620	590
Flow rate on manifold rail G $\frac{1}{8}$	[l/min]	610	520	620	630	620	590
Vacuum operation at port 1	No	Only with external pilot air supply					
Design	Piston spool valve						
Type of mounting	On manifold rail						
Electrical connection	Via connecting plate						
Manual override	Choice of non-detenting/detenting (standard), non-detenting or covered						

- 1) C = Normally closed
- 2) U = Normally open
- 3) E = Normally exhausted
- 4) H=2x 3/2-way valve in one housing with 1x normally closed and 1x normally open

Operating conditions	Download CAD data → www.festo.com					
	T32-A ⁵⁾	T32-M ⁶⁾	M52-A ⁵⁾	B52	M52-M ⁶⁾	P53
Operating medium	Compressed air to ISO 8573-1:2010 [7:4:4]					
Operating pressure	Internal	1.5 ... 8	2 ... 8	2.5 ... 8	1.5 ... 8	3 ... 8
	External	1.5 ... 10	–0.9 ... 10		–0.9 ... 8	–0.9 ... 10
Pilot pressure ⁷⁾	1.5 ... 8	2 ... 8	2.5 ... 8	1.5 ... 8	3 ... 8	
Ambient temperature	[°C]	–5 ... +60				
Temperature of medium	[°C]	–5 ... +60				

- 5) Pneumatic spring
- 6) Mechanical spring
- 7) Minimum pilot pressure 50% of operating pressure

Materials	
Housing	Wrought aluminium alloy
Seals	HNBR, NBR

Valve terminals VTUG with multi-pin plug and fieldbus connection

Order code

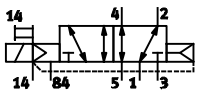
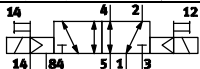
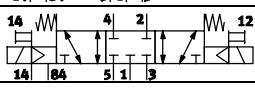
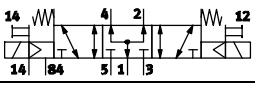
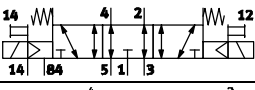
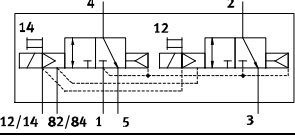
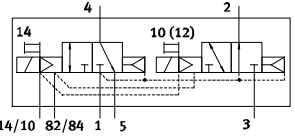
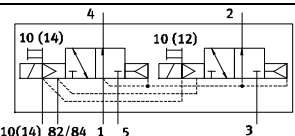
VUVG	-	14	-	-
Valve design				
Semi in-line valve	S			
Width				
14 mm	14			
Valve function				
				M52
				B52
				P53C
				P53U
				P53E
				T32C
				T32H
				T32U



								Display	
								L LED	
								Electrical connection	
								T1 Plug-in	
								Nominal operating voltage	
								1 24 V DC	
								Pneumatic connection	
								G18 G1/8	
								T14 Push-in connector 1/4"	
								T516 Push-in connector 5/16"	
								Q4 Push-in connector 4 mm	
								Q6 Push-in connector 6 mm	
								Q8 Push-in connector 8 mm/G1/8	
								Manual override	
								H Non-detenting	
								S Covered	
								T Non-detenting, detenting	
								Pilot air	
								Z External	
								Reset method	
								A Pneumatic spring for M52 and 2x3/2-way	
								M Mechanical spring for M52 and 2x3/2-way	
								- With B52 and P53	

9

Valve terminals VTUG with multi-pin plug and fieldbus connection

FESTO

Technical data – Sub-base valve M5/M7

-  Width 10 mm
-  Flow rate
130 ... 300 l/min
-  Operating voltage
24 V DC

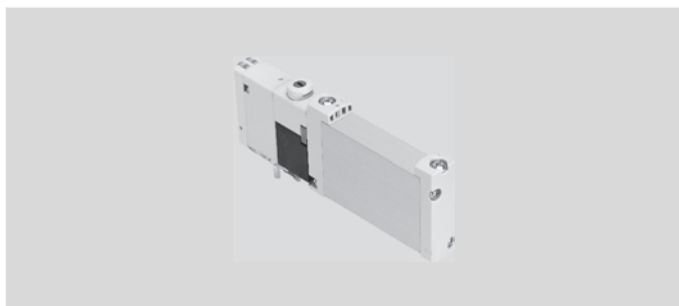

Technical data	Download CAD data → www.festo.com											
	T32-A			T32-M			M5/2-R	B52	M52-M	P53		
Valve function	C ¹⁾	U ²⁾	H ⁴⁾	C ¹⁾	U ²⁾	H ⁴⁾	–	–	–	C ¹⁾	U ²⁾	E ³⁾
Normal position	C ¹⁾	U ²⁾	H ⁴⁾	C ¹⁾	U ²⁾	H ⁴⁾	–	–	–	C ¹⁾	U ²⁾	E ³⁾
Pneumatic spring reset method	Yes			No			Yes ⁵⁾	–	No	–		
Mechanical spring reset method	No			Yes			Yes ⁵⁾	–	Yes	–		
Stable position	Monostable							Bistable	Monostable			
Port 1, 3, 5	On manifold rail											
Port 2, 4	M5/M7											
Port 12, 14	On manifold rail											
Standard nominal flow rate M5/M7	[l/min]			160	140	300	260					
Flow rate on manifold rail M5, front	[l/min]			150	130	220			200			
Flow rate on manifold rail M7, front	[l/min]			160	140	270	240		250			
Flow rate on manifold rail M7, underneath	[l/min]			160	140	300	260					
Vacuum operation at port 1	No			Only with external pilot air supply								
Design	Piston spool valve											
Type of mounting	On manifold rail											
Electrical connection	Via connecting plate											
Manual override	Choice of non-detenting/detenting (standard), non-detenting or covered											

- 1) C = Normally closed
- 2) U = Normally open
- 3) E = Normally exhausted
- 4) H=2x 3/2-way valve in one housing with 1x normally closed and 1x normally open
- 5) Combined reset method

Operating conditions		T32-A ⁶⁾	T32-M ⁷⁾	M5/2-R ⁸⁾	B52	M52-M ⁷⁾	P53
Operating medium		Compressed air to ISO 8573-1:2010 [7:4:4]					
Operating pressure	Internal	1.5 ... 8	2 ... 8	2.5 ... 8	1.5 ... 8	3 ... 8	
	External	1.5 ... 10	–0.9 ... 10			–0.9 ... 8	–0.9 ... 10
Pilot pressure ⁹⁾		1.5 ... 8	2 ... 8	2.5 ... 8	1.5 ... 8	3 ... 8	
Ambient temperature	[°C]	–5 ... +60					
Temperature of medium	[°C]	–5 ... +60					

- 6) Pneumatic spring
- 7) Mechanical spring
- 8) Pneumatic/mechanical spring
- 9) Minimum pilot pressure 50% of operating pressure

Materials	
Housing	Wrought aluminium alloy
Seals	HNBR, NBR

Valve terminals VTUG with multi-pin plug and fieldbus connection

Order code

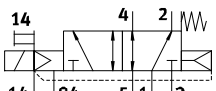
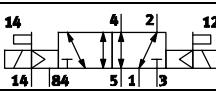
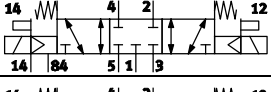
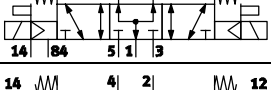
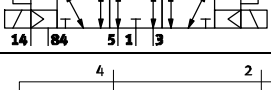
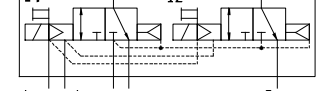
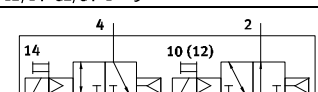
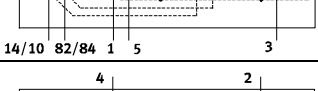
VUVG	-	10	-	-
Valve design				
Sub-base valve	B			
Width				
10 mm	10			
Valve function				
	M52			
	B52			
	P53C			
	P53U			
	P53E			
	T32C			
	T32H			
	T32U			

Display	
L	LED
Electrical connection	
T1	Plug-in
Nominal operating voltage	
1	24 V DC
Pneumatic connection	
F	Flange/sub-base
Manual override	
H	Non-detenting
S	Covered
T	Non-detenting, detenting
Pilot air	
Z	External
Reset method	
A	Pneumatic spring for 2x3/2-way
M	Mechanical spring for M52 and 2x3/2-way
R	Pneu./mech. spring for M52
-	With B52 and P53

9

Ordering – Product options

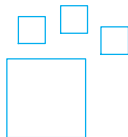

Configurable product

This product and all its options can be ordered using the configurator.

The configurator can be found under [Products on the DVD](#) or www.festo.com/catalogue/...

Enter the type code in the search field.

★ Quick ordering



Part No.	Type
Sub-base valve B10, 3/2-way valve	
573410	VUVG-B10-T32C-AZT-F-1T1L
573413	VUVG-B10-T32C-MZT-F-1T1L
Sub-base valve B10, 5/2-way single solenoid valve	
573417	VUVG-B10-M52-MZT-F-1T1L
573416	VUVG-B10-M52-RZT-F-1T1L

Part No.	Type
Sub-base valve B10, 5/2-way double solenoid valve	
573418	VUVG-B10-B52-ZT-F-1T1L
Sub-base valve B10, 5/3-way valve	
573419	VUVG-B10-P53C-ZT-F-1T1L

Valve terminals VTUG with multi-pin plug and fieldbus connection

FESTO

Technical data – Sub-base valve G $\frac{1}{8}$

-  Width 14 mm
-  Flow rate
440 ... 560 l/min
-  Operating voltage
24 V DC

Download CAD data → www.festo.com

Technical data	T32-A	T32-M	M52-A	B52	M52-M	P53
Valve function	C ¹⁾ U ²⁾ H ⁴⁾	C ¹⁾ U ²⁾ H ⁴⁾	–	–	–	C ¹⁾ U ²⁾ E ³⁾
Normal position	C ¹⁾ U ²⁾ H ⁴⁾	C ¹⁾ U ²⁾ H ⁴⁾	–	–	–	C ¹⁾ U ²⁾ E ³⁾
Pneumatic spring reset method	Yes	No	Yes	–	No	–
Mechanical spring reset method	No	Yes	No	–	Yes	–
Stable position	Monostable			Bistable	Monostable	
Port 1, 3, 5	On manifold rail					
Port 2, 4	G $\frac{1}{8}$					
Port 12, 14	On manifold rail					
Standard nominal flow rate G18	[l/min] 530	470	550	560	550	510
Flow rate on manifold rail G18, front	[l/min] 490	440	500	510	500	470
Flow rate on manifold rail G18, underneath	[l/min] 530	470	550	560	550	510
Vacuum operation at port 1	No	Only with external pilot air supply				
Design	Piston spool valve					
Type of mounting	On manifold rail					
Electrical connection	Via connecting plate					
Manual override	Choice of non-detenting/detenting (standard), non-detenting or covered					

- 1) C = Normally closed
 2) U = Normally open
 3) E = Normally exhausted
 4) H=2x 3/2-way valve in one housing with 1x normally closed and 1x normally open

Operating conditions

Valve function	T32-A ⁵⁾	T32-M ⁶⁾	M52-A ⁵⁾	B52	M52-M ⁶⁾	P53
Operating medium	Compressed air to ISO 8573-1:2010 [7:4:4]					
Operating pressure	Internal	1.5 ... 8	2 ... 8	2.5 ... 8	1.5 ... 8	3 ... 8
	External	1.5 ... 10	–0.9 ... 10		–0.9 ... 8	–0.9 ... 10
Pilot pressure ⁷⁾	1.5 ... 8	2 ... 8	2.5 ... 8	1.5 ... 8	3 ... 8	
Ambient temperature	[°C] –5 ... +60					
Temperature of medium	[°C] –5 ... +60					





- 5) Pneumatic spring
 6) Mechanical spring
 7) Minimum pilot pressure 50% of operating pressure

Materials

Housing	Wrought aluminium alloy
Seals	HNBR, NBR

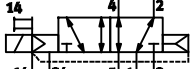
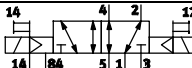
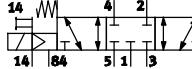
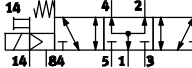
Valve terminals VTUG with multi-pin plug and fieldbus connection

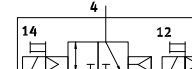
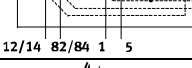
Order code

VUVG	-	14	-	-
Valve design				
Sub-base valve	B			
Width				
14 mm	14			
Valve function				
				M52
				B52
				P53C
				P53U
				P53E
				T32C
				T32H
				T32U

				Display	
				L LED	
				Electrical connection	
				T1 Plug-in	
				Nominal operating voltage	
				1 24 V DC	
				Pneumatic connection	
				F Flange/sub-base	
				Manual override	
				H Non-detenting	
				S Covered	
				T Non-detenting, detenting	
				Pilot air	
				Z External	
				Reset method	
				A Pneumatic spring for M52 and 2x3/2-way	
				M Mechanical spring for M52 and 2x3/2-way	
				- With B52 and P53	

9

Ordering – Product options

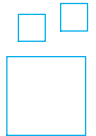

Configurable product

This product and all its options can be ordered using the configurator.

The configurator can be found under [Products on the DVD](#) or www.festo.com/catalogue/... Enter the type code in the search field.

★ Quick ordering

Part No.	Type
Sub-base valve B14, 3/2-way valve	
573476	VUVG-B14-T32C-AZT-F-1T1L
573479	VUVG-B14-T32C-MZT-F-1T1L
Sub-base valve B14, 5/2-way single solenoid valve	
573482	VUVG-B14-M52-AZT-F-1T1L
573483	VUVG-B14-M52-MZT-F-1T1L

Part No.	Type
Sub-base valve B14, 5/2-way double solenoid valve	
573484	VUVG-B14-B52-ZT-F-1T1L
Sub-base valve B14, 5/3-way valve	
573485	VUVG-B14-P53C-ZT-F-1T1L

Valve terminals VTUG with multi-pin plug and fieldbus connection

FESTO

Technical data – Manifold rail VABM

Technical data		Download CAD data → www.festo.com	
Type		VABM-L1-10	VABM-L1-14
Connection type		Semi in-line/sub-base	
Connection	12/14	M5	
	82/84	M5	
	2, 4	M5/M7	G1/8
	1, 3, 5	G1/8	G1/4
Max. number of valve positions		24	

Information on materials		Download CAD data → www.festo.com	
Housing		Wrought aluminium alloy	
Seals		HNBR, NBR	

Technical data – Multi-pin plug connection

The following multi-pin plug connections are available for the valve terminal

VTUG:

- Sub-D (25-pin)
- Sub-D (44-pin)
- Flat cable (26-pin)
- Flat cable (50-pin)



Technical data		Download CAD data → www.festo.com			
Type		VAEM-L1-S-M1-25	VAEM-L1-S-M1-44	VAEM-L1-S-M3-26	VAEM-L1-S-M3-50
Number of pins		25-pin	44-pin	26-pin	50-pin
Electrical connection		Sub-D plug		Flat cable plug	
Max. number of valve positions		24		24	

Valve terminals VTUG with multi-pin plug and fieldbus connection

Technical data – I-Port interface/IO-Link

Festo-specific, standardised interface for direct connection to the fieldbus by mounting the bus node CTEU or to an IO-Link master via a cable (in IO-Link mode).

The following protocols are supported in combination with the associated CTEU node:

- CANopen
- DeviceNet
- PROFIBUS
- CC-LINK
- EtherCAT

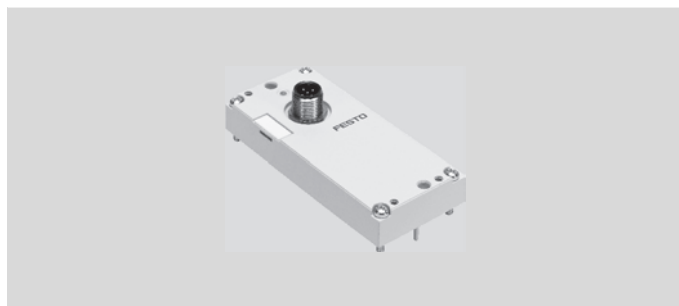

Technical data			Download CAD data → www.festo.com
Communication types	IO-Link		
Electrical connection	<ul style="list-style-type: none"> • M12 plug, 5-pin • A-coded • Metal thread for screening 		
Baud rate	COM3	[kbps]	230.4
	COM2	[kbps]	38.4
Max. number of solenoid coils	VAEM-L1-S-8-PT		16
	VAEM-L1-S-16-PT		32
	VAEM-L1-S-24-PT		48
Max. number of valve positions	VAEM-L1-S-8-PT		8
	VAEM-L1-S-16-PT		16
	VAEM-L1-S-24-PT		24
Ambient temperature		[°C]	-5 ... +50

Technical data – Adapter CAPC

Application

- M12 connection technology (two interfaces)
- Enables the installation of valve terminals or other devices over a distance of 20 metres
- Accessory CAFM enables the sub-base to be installed on an H-rail

Function

The adapter CAPC enables decentralised installation of fieldbus nodes CTEU on a valve terminal or input modules with I-Port interface.



Technical data		
Type	CAPC-F1-E-M12	
Dimensions W x L x H	[mm]	50 x 148 x 28
Fieldbus interface	2 x M12 socket, 5-pin	
Operating voltage range	[V DC]	18 ... 30
Max. power supply	[A]	2
Nominal operating voltage	[V DC]	24
Cable length	[m]	20

Pin allocation – Power supply/IO-Link interfaces

	Pin	Designation	Function
	1	Supply PS (+24 V)	Power supply for system +24 V
	2	Load supply PL (+24 V)	Power supply for load +24 V
	3	Supply PS (0 V)	Power supply for system +24 V
	4	Communication signal C/Q	Communication signal C/Q
	5	Load supply PL (0V)	Power supply for load 0 V
			Metal thread for FE

Valve terminals VTUG with multi-pin plug and fieldbus connection

FESTO

Order code

VABM	-	-	-	-
Allocation				
Manifold rail	L1			
Width				
Size 10				10
Size 14				14
Version				
Standard				-
High flow rate				H
Connection type				
Semi in-line				G
Sub-base				W
Connection direction				
To the side				-
Underneath				B
Pneumatic connection				
G1/8				G18
G1/4				G14

-	-			
Outlet direction of electrical components				
-				Upwards
Circuitry				
-				None
R				Holding current reduction with protective circuit
Electrical connection				
-				None
G				Preparation for electrical connection
Connection for valve function				
-				5/2
M				5/2-way, single solenoid
Valve positions				
4				4 valve positions
5				5 valve positions
6				6 valve positions
7				7 valve positions
8				8 valve positions
9				9 valve positions
10				10 valve positions
12				12 valve positions
16				16 valve positions
20				20 valve positions
24				24 valve positions

Valve terminals VTUG with multi-pin plug and fieldbus connection

Accessories

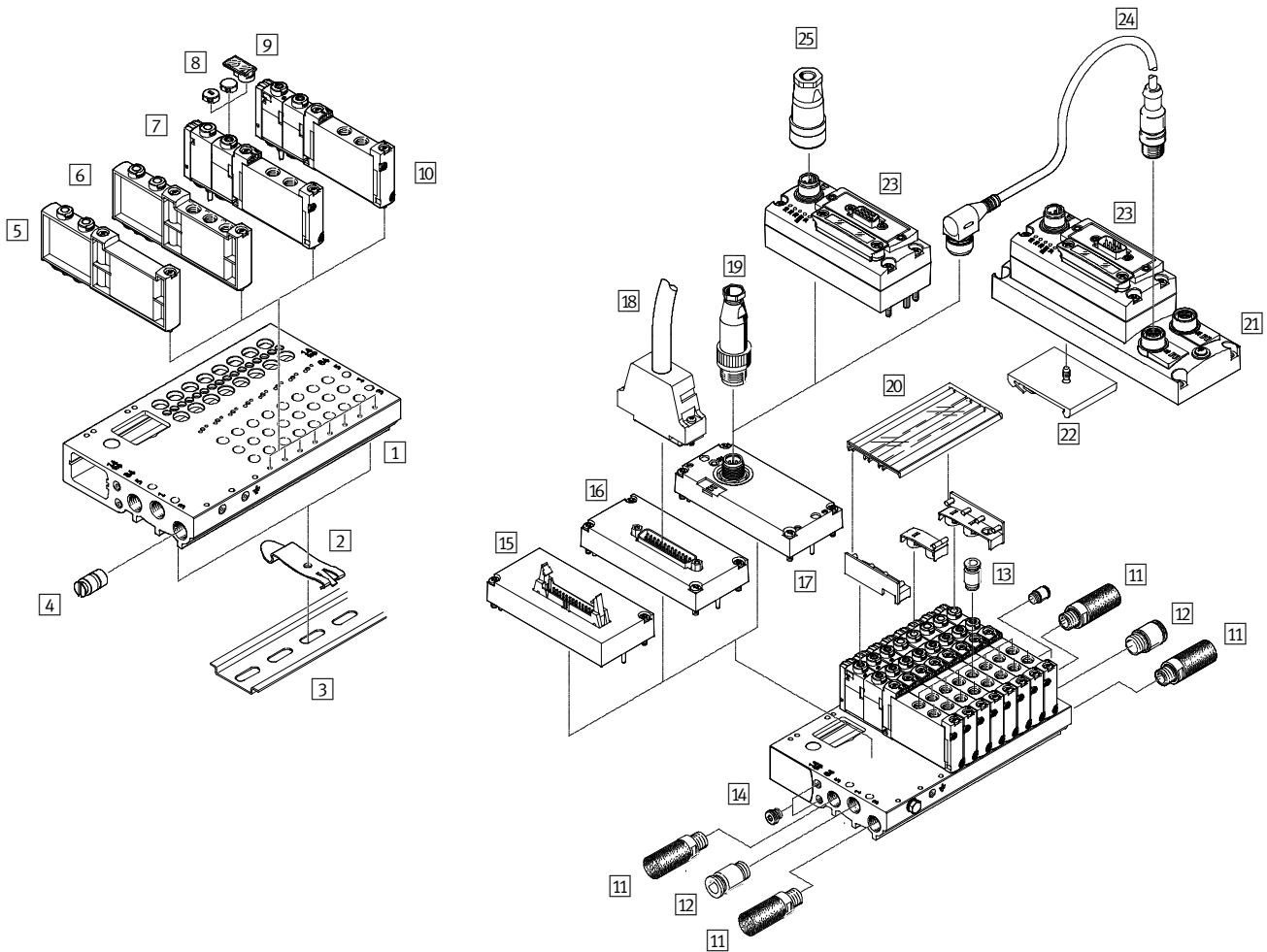









9

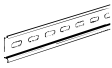



				→ Page/online
1	Manifold rail	VABM-L1	For 4 to 10, 12, 14, 16, 20 and 24 valve positions	657
2	H-rail mounting	VAME-T-M4	2 pieces for fitting the valve terminal on an H-rail	659
3	H-rail	NRH-35-2000	For mounting the valve terminal	659
4	Separator	VABD	For creating pressure zones	659
5	Blanking plate	VABB-L1	For covering an unused valve position	659
6	Supply plate	VABF-L1	For air supply port 1 and outlet port 3 and 5	659
7	Solenoid valve	VUVG	Semi in-line valve, 5/2-way valve, single solenoid	647
8	Cover cap	VMPA-HB	Cover cap for manual override	659
9	Inscription label holder	ASLR-D-L1	For inscription label and covering the mounting screw/manual override	659
10	Solenoid valve	VUVG	Semi in-line valve, 5/2-way valve, single solenoid	647
11	Silencer	U	For outlet port 3 and 5	659
12	Push-in fitting	QS	Push-in fitting for air supply port 1	659
13	Push-in fitting	QS	For port 2/4	659
14	Blanking plug	B	For internal/external pilot air	659
15	Electrical interface	VAEM-L1-S-M3	Flat cable	659
16	Electrical interface	VAEM-L1-S-M1	Sub-D	659
17	I-Port interface	VAEM-L1-S	IO-Link	659
18	Connecting cable	NEBV	Sub-D cable	660
19	Plug	SEA-M12-5GS-PG7	Straight plug for I-Port interface/IO-Link	660
20	Inscription label holder	ASCF-H-L1	For identifying valves	660
21	Adapter	CAPC-F1-E-M12	For connecting a second device with I-Port interface	660
22	H-rail mounting	CAFM-F1-H	For adapter CAPC	660
23	Bus node	CTEU	Fieldbus node	660
24	Connecting cable	NEBU	For I-Port interface/IO-Link	660
25	Power supply socket	NTSD	Power supply for fieldbus node CTEU	cteu

Valve terminals VTUG with multi-pin plug and fieldbus connection

FESTO

Accessories – Ordering data

		Part No.	Type
2 H-rail mounting			
	-	★ 569998	VAME-T-M4
3 H-rail			
	-	35430	NRH-35-2000
4 Separator			
	10 mm	★ 569994	VABD-6-B
	10 mm	★ 569995	VABD-8-B
	14 mm	★ 569996	VABD-10-B
5 Blanking plate			
	10 mm	★ 573422	VABB-L1-10-T
	14 mm	★ 573488	VABB-L1-14-T
6 Supply plate			
	10 mm	★ 573924	VABF-L1-10-P3A4-M7-T1
	14 mm	★ 573925	VABF-L1-14-P3A4-G18-T1
8 Cover cap for manual override			
	Covered	540898	VMPA-HBV-B
	Non-detenting	540897	VMPA-HBT-B
9 Inscription label holder			
	10 pieces	★ 570818	ASLR-D-L1
11 Silencer Technical data → 994			
	M5	165003	UC-M5
	M7	161418	UC-M7
	G1/8	161419	UC-1/8
	G1/4	165004	UC-1/4
12/13 Push-in fitting, straight Technical data → 908			
	Thread M5		
	3 mm	★ 153313	QSM-M5-3-I
	4 mm	★ 153315	QSM-M5-4-I
	Thread M7		
	4 mm	★ 153319	QSM-M7-4-I
	Thread G1/8		
	4 mm	★ 186106	QS-G1/8-4-I
	6 mm	★ 186107	QS-G1/8-6-I
	8 mm	★ 186109	QS-G1/8-8-I

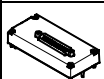
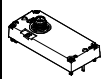
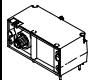
		Part No.	Type
12/13 Push-in fitting, angled Technical data → 908			
	Thread M5		
	∅ 3 mm	★ 153331	QSML-M5-3
	∅ 4 mm	★ 153333	QSML-M5-4
	Thread M7		
	∅ 4 mm	★ 186352	QSML-M7-4
	Thread G1/8		
	∅ 6 mm	★ 186117	QSL-G1/8-6
	∅ 8 mm	★ 186119	QSL-G1/8-8
Angled, long			
	Thread M5		
	∅ 3 mm	★ 130838	QSMLL-M5-3
	∅ 4 mm	★ 153339	QSMLL-M5-4
	Thread M7		
	∅ 4 mm	★ 186354	QSMLL-M7-4
	Thread G1/8		
	∅ 6 mm	★ 186128	QSLL-G1/8-6
	∅ 8 mm	★ 186130	QSLL-G1/8-8
14 Blanking plug Technical data → b-1			
	M5	174308	B-M5-B
	M7	174309	B-M7
	G1/8	3568	B-1/8
	G1/4	3569	B-1/4
15/16/17 Electrical interface, flat cable plug			
	26-pin	★ 573452	VAEM-L1-S-M3-26
	50-pin	★ 573451	VAEM-L1-S-M3-50
Sub-D			
	25-pin	★ 573445	VAEM-L1-S-M1-25
		573447	VAEM-L1-S-M1-25V1
		573448	VAEM-L1-S-M1-25V2
		573449	VAEM-L1-S-M1-25V3
		573450	VAEM-L1-S-M1-25V4
	44-pin	★ 573446	VAEM-L1-S-M1-44
I-Port interface, outlet on top			
	8 VP ¹⁾	★ 573384	VAEM-L1-S-8-PT
	16 VP ²⁾	★ 573939	VAEM-L1-S-16-PT
	24 VP ³⁾	★ 573940	VAEM-L1-S-24-PT
I-Port interface, outlet on side			
	8 VP ¹⁾	574207	VAEM-L1-S-8-PTL
	16 VP ²⁾	574208	VAEM-L1-S-16-PTL
	24 VP ³⁾	574209	VAEM-L1-S-24-PTL

- 1) Actuation of up to 8 double solenoid valve positions
- 2) Actuation of up to 16 double solenoid valve positions
- 3) Actuation of up to 24 double solenoid valve positions

Valve terminals VTUG with multi-pin plug and fieldbus connection

Accessories – Ordering data

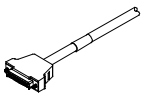
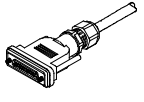
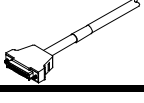
		Part No.	Type	
18 Connecting cable for multi-pin plug connection, 25-pin, IP40 Technical data online: → kmp				
	2.5 m	530046	KMP6-25P-20-2,5	
	5 m	530047	KMP6-25P-20-5	
	10 m	530048	KMP6-25P-20-10	
25-pin, IP67 Technical data online: → nebv				
	2.5 m	538225	NEBV-S1G25-K-2.5-N-LE25	
	5 m	538226	NEBV-S1G25-K-5-N-LE25	
	10 m	538227	NEBV-S1G25-K-10-N-LE25	
44-pin, IP40 Technical data online: → nebv				
	2.5 m	575113	NEBV-S1G44-K-2.5-N-LE44-S6	
	5 m	575114	NEBV-S1G44-K-5-N-LE44-S6	
	10 m	575115	NEBV-S1G44-K-10-N-LE44-S6	

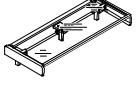
		Part No.	Type	
19 Straight plug, for I-Port/IO-Link, 5-pin Technical data online: → sea				
	M12	175487	SEA-M12-5GS-PG7	
20 Inscription label holder for valve terminal				
	Width 10 mm			
	4 VP ¹⁾	573453	ASCF-H-L1-10-4V	
	5 VP ¹⁾	573454	ASCF-H-L1-10-5V	
	6 VP ¹⁾	573455	ASCF-H-L1-10-6V	
	7 VP ¹⁾	573456	ASCF-H-L1-10-7V	
	8 VP ¹⁾	573457	ASCF-H-L1-10-8V	
	9 VP ¹⁾	573458	ASCF-H-L1-10-9V	
	10 VP ¹⁾	573459	ASCF-H-L1-10-10V	
	12 VP ¹⁾	573460	ASCF-H-L1-10-12V	
	16 VP ¹⁾	573461	ASCF-H-L1-10-16V	
	20 VP ¹⁾	573462	ASCF-H-L1-10-20V	
	24 VP ¹⁾	573463	ASCF-H-L1-10-24V	
	Width 14 mm			
	4 VP ¹⁾	573511	ASCF-H-L1-14-4V	
	5 VP ¹⁾	573512	ASCF-H-L1-14-5V	
	6 VP ¹⁾	573513	ASCF-H-L1-14-6V	
	7 VP ¹⁾	573514	ASCF-H-L1-14-7V	
	8 VP ¹⁾	573515	ASCF-H-L1-14-8V	
	9 VP ¹⁾	573516	ASCF-H-L1-14-9V	
	10 VP ¹⁾	573518	ASCF-H-L1-14-10V	
	12 VP ¹⁾	573519	ASCF-H-L1-14-12V	
	16 VP ¹⁾	573520	ASCF-H-L1-14-16V	
	20 VP ¹⁾	573521	ASCF-H-L1-14-20V	
	24 VP ¹⁾	573522	ASCF-H-L1-14-24V	

1) VP = Valve positions

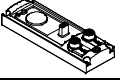
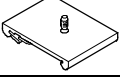
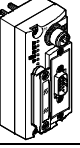
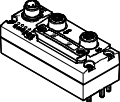
		Part No.	Type	
21 Adapter				
	-	570042	CAPC-F1-E-M12	
22 H-rail mounting				
	For adapter CAPC	570043	CAFH-F1-H	
23 Bus node				
	CANopen	★	570038	CTEU-CO
	CC-Link	★	1544198	CTEU-CC
	PROFIBUS	★	570040	CTEU-PB
	DeviceNet	★	570039	CTEU-DN
	EtherCAT	★	572556	CTEU-EC

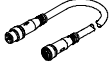
		Part No.	Type	
24 Connecting cable for I-Port interface/IO-Link Technical data → 949				
	5 m	574321	NEBU-M12G5-E-5-Q8N-M12G5	
	7.5 m	574322	NEBU-M12G5-E-7.5-Q8N-M12G5	
	10 m	574323	NEBU-M12G5-E-10-Q8N-M12G5	

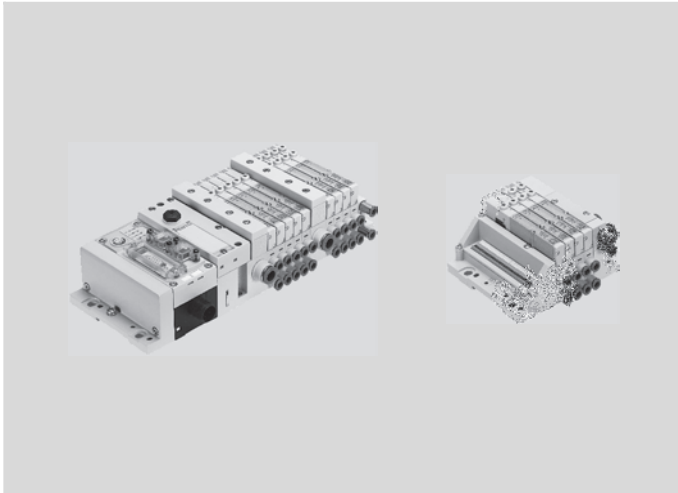

- Universal valve terminal for numerous industries
- Individual modularity for each valve position, valves can be easily combined or expanded later
- Subsequent conversions possible quickly and easily at any time
- Sub-bases made of plastic - especially light and corrosion resistant
- End plates made of coated aluminium - high resistance and long service life

→ www.festo.com/catalogue/mpa-l

Product range overview

Electrical connection	Max. number of valve positions	Size			→ Page/ online
		MPA1 (width 10 mm)	MPA14 (width 14 mm)	MPA2 (width 20 mm)	
Multi-pin plug connection	32	■	■	■	664
I-Port interface/IO-Link	32	■	■	■	664
Fieldbus connection (CPX terminal)	32	■	■	■	664

Valve types

I	2x 2/2-way valve, 1x normally closed and 1x normally open, reversible	NS	2x 3/2-way valve, normally open, mechanical spring return	HS	2x 3/2-way valve, 1x normally open, 1x normally closed, mechanical spring return	J	5/2-way valve, double solenoid
D	2x 2/2-way valve, normally closed	NU	2x 3/2-way valve, normally open, polymer poppet valve	HU	2x 3/2-way valve, 1x normally open, 1x normally closed, polymer poppet valve	B	5/3-way valve, mid-position pressurised
DS	2x 2/2-way valve, normally closed, mechanical spring return	K	2x 3/2-way valve, normally closed	M	5/2-way valve, single solenoid	G	5/3-way valve, mid-position closed
X	3/2-way valve, normally closed, external supply air	KS	2x 3/2-way valve, normally closed, mechanical spring return	MS	5/2-way valve, single solenoid, mechanical spring return	E	5/3-way valve, mid-position exhausted
W	3/2-way valve, normally open, external supply air	KU	2x 3/2-way valve, normally closed, polymer poppet valve	MU	5/2-way valve, single solenoid, polymer poppet valve	L	Blanking plate for vacant position
N	2x 3/2-way valve, normally open	H	2x 3/2-way valve, 1x normally open, 1x normally closed				

Note

Valve terminals can be ordered quickly and easily online.
The convenient product configurator can be found at:

→ www.festo.com/catalogue/mpa-l

Key features

Innovative

- Slim high-performance valves in a sturdy metal housing
- Flow rates up to 870 l/min
- Wide range of electrical connection options for multi-pin plug: Sub-D, flat cable or terminal strip
- Connection to the electrical peripherals CPX with a wide range of communication options
- I-Port/IO-Link interface
- Freely configurable push-in connectors

Versatile

- Modular system offering a range of configuration options
- Freely extendable system with individual sub-bases and modular tie rods
- Up to 32 solenoid coils
- Conversions and extensions possible at a later date
- Air supply can be extended by means of additional pressure zones with supply modules
- Wide range of pressures
–0.9 ... 10 bar
- Wide range of valve functions

Reliable

- High output reserves thanks to large pneumatic cross sections and venting with high flow rates
- Lightweight and low-cost polymer components
- Fast troubleshooting thanks to LEDs on the valves
- Easy to service thanks to replaceable valves and electrical modules
- Manual override either non-detenting, detenting or secured against unauthorised activation (covered)
- Durable thanks to the use of tried-and-tested piston spool valves

Easy to mount

- Fast and reliable in-house assembly using individual components or delivered as a ready-to-install and tested unit
- Lower selection, ordering, installation and commissioning costs
- Secure mounting on wall or H-rail

Electrical connection options

Multi-pin plug connection

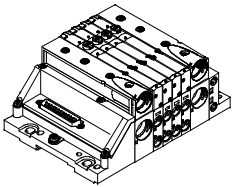

The signal flow from the controller to the valve terminal takes place via a pre-assembled or self-assembled multi-wire cable to the multi-pin plug connection, which substantially reduces installation time.

The valve terminal can be equipped with max. 32 solenoid coils. This corresponds to 2 to 32 valves.

Versions

- Sub-D connection
 - Pre-assembled multi-pin cable
 - Multi-pin cable for self-assembly
- Flat cable connection
- Terminal strip connection

Fieldbus connection via the CPX system

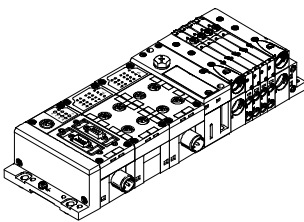

An integrated fieldbus node manages communication with a higher-order PLC. This enables a space-saving pneumatic and electronic solution. Valve terminals with fieldbus interfaces can be configured with up to 32 valve positions.

The CPX terminal also enables the integration of digital and analogue electrical inputs and outputs, pressure sensors and controllers for pneumatic or electric positioning axes.

A detailed description of the extensive functionality can be found in the documentation for the CPX terminal

→ 677

Fieldbus protocols/CPX variants:

- PROFIBUS DP
- PROFINET
- INTERBUS
- DeviceNet
- CANopen
- CC-Link
- EtherNet/IP
- Front End Controller Remote I/O
- Modbus/TCP
- EtherCAT

Control block connection via the CPX system

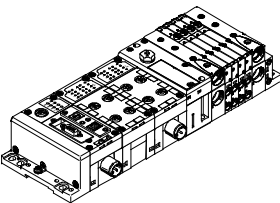

Controllers integrated in the Festo valve terminals enable the construction of stand-alone control units to IP65, without control cabinets.

In the slave operating mode, these valve terminals can be used for intelligent preprocessing and are therefore ideal modules for designing decentralised intelligence.

In the master operating mode, terminal groups can be designed with many options and functions that can autonomously control a medium-sized machine/system.

Key features

Electrical connection options

I-Port interface/IO-Link, CTEL installation system

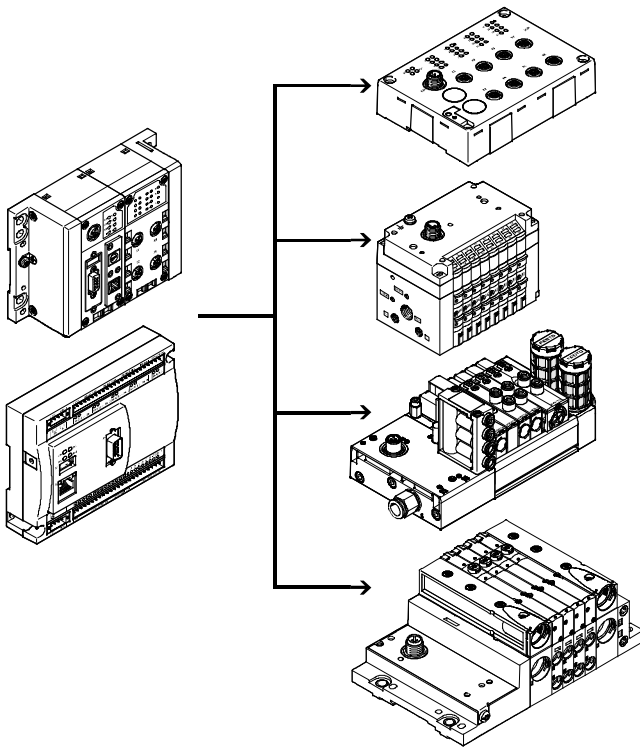

A CTEL system consists of the CTEL master and the devices with I-Port interface, which are connected using special connecting cables. This permits a decentralised layout of the devices. This means that the valve terminals and I/O modules with I-Port interface (devices) can be mounted very close to the cylinders to be controlled. This reduces the length of the air supply lines used, which minimises flow losses and pressurisation and venting times.

The I-Port interface from Festo is based on IO-Link and is compatible with IO-Link in certain areas.

The connection type corresponds to a star topology. In other words, only one module or valve terminal can be connected to each I-Port.

As well as communication, the I-Port interfaces also handle the power supply for the connected devices. The maximum length of a string is 20 m.

The restrictions compared to IO-Link include:

- Permanently set baud rate of 230.4 kbps
- SIO mode is not supported
- Max. 32 bytes of input data and 32 bytes of output data
- Only one dump of the master commands is used
- Festo plug and work, configuration via IODD is not supported.

Fieldbus connection via the CTEU system

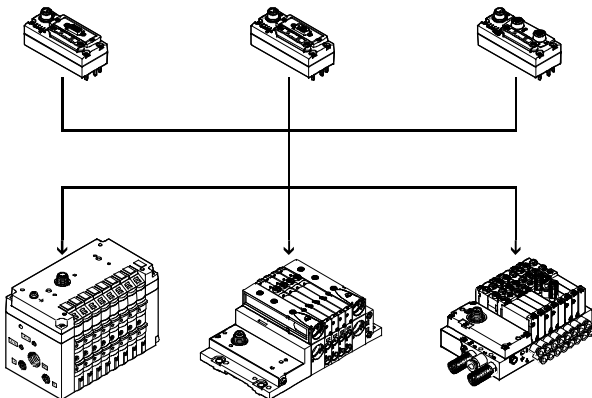

CTEU is a system for the compact connection of a valve terminal to different fieldbus standards such as PROFIBUS and DeviceNet.

The fieldbus node is mounted directly on the I-Port interface of the valve terminal.

This makes it easy to switch between the fieldbus protocols; however, there is no way of connecting I/O modules to the fieldbus nodes.



The following fieldbus protocols are supported:

- DeviceNet
- PROFIBUS DP
- CANopen
- CC-Link
- EtherCAT

Valve terminals MPA-L

Technical data

Valve terminal with multi-pin plug or fieldbus connection

-  - Flow rate
Up to 870 l/min
-  - Operating voltage
24 V DC
-  - Valve width
10 mm
14 mm
20 mm

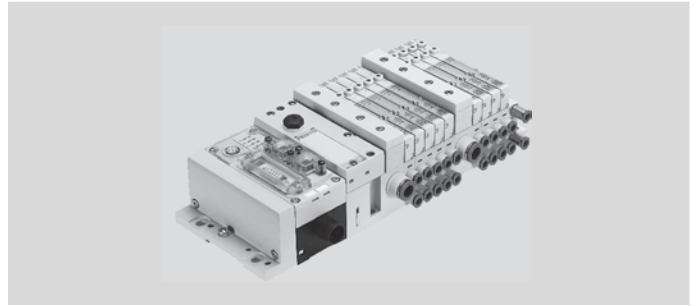

Download CAD data → www.festo.com

Technical data	
Max. number of valve positions	32
Max. number of pressure zones	9
Lubrication	Life-time lubrication, PWIS-free (free of paint-wetting impairment substances)
Type of mounting	Wall mounting On H-rail to EN 60715
Standard nominal flow rate	[l/min.] Max. 700
Manual override	Non-detenting, detenting, blocked
Nominal voltage	[V DC] 24
Operating voltage range	[V DC] 21.6 ... 26.4

Operating conditions	
Operating medium	Compressed air to ISO 8573-1:2010 [7:4:4]
Note on operating/pilot medium	Lubricated operation possible (in which case lubricated operation will always be required)
Operating pressure	[bar] -0.9 ... +10
Pilot pressure	[bar] 3 ... 8
Ambient temperature	[°C] -5 ... +50

		Width		
		10 mm	14 mm	20 mm
Nominal pick-up current	[mA]	50	50	110
Nominal current with current reduction	[mA]	10	10	23
Time until current reduction	[ms]	20	20	20

Electrical data – MPA-L with electrical interface for CPX terminal	
Intrinsic current consumption of valve terminal (internal electronics, without valves)	
At 24 V $U_{EL/SEN}$ ¹⁾	[mA] Typically 13
At 24 V U_{val} ²⁾	[mA] Typically 35
Diagnostic message	
Undervoltage U_{OFF} ³⁾	[V] 17.7 ... 17.8

- 1) Power supply for electronics and sensors
- 2) Load voltage supply for valves
- 3) Load voltage outside of function range

Electrical data – MPA-L with I-Port interface/IO-Link	
Intrinsic current consumption of valve terminal (internal electronics, without valves)	
Operating voltage	[mA] 30
Load voltage	[mA] 30

Technical data

Technical data – Valve width 10 mm

Code for position function 1-32		M	J	N	K	H	B	G	E	X	W	D	I
Switching times	On [ms]	10	10	10	10	10	10	10	10	10	10	10	8
	Off [ms]	20	–	20	20	20	35	35	35	20	20	20	20
	Change-over [ms]	–	15	–	–	–	15	–	15	–	–	–	–
Operating pressure [bar]	–0.9 ... +10			3 ... 10			–0.9 ... +10					3 ... 10	
Standard nominal flow rate [l/min]	360	360	300	230	300	300	320	240	255	255	230	260	
Design	Piston spool valve												
Materials	Die cast aluminium												

Technical data – Valve width 10 mm

Code for position function 1-32		NS	KS	HS	DS	MU	NU	KU	HU
Switching times	On [ms]	10	10	10	10	10	8	8	8
	Off [ms]	20	20	20	20	12	8	10	10
	Change-over [ms]	–	–	–	–	–	–	–	–
Operating pressure [bar]	–0.9 ... +8					–0.9 ... +10			
Standard nominal flow rate [l/min]	300	230	300	230	190	190	160	190	
Design	Piston spool valve					Poppet valve with spring return			
Materials	Die cast aluminium					PPA reinforced			

Technical data – Valve width 14 mm

Code for position function 1-32		M	J	N	K	H	B	G	E	D
Switching times	On [ms]	13	22	12	12	12	16	13	13	12
	Off [ms]	30	–	38	38	38	50	52	50	30
	Change-over [ms]	–	24	–	–	–	26	26	26	–
Operating pressure [bar]	–0.9 ... +10									
Standard nominal flow rate [l/min]	670	670	650	600	650	630	610	480	650	
Design	Piston spool valve									
Materials	Die cast aluminium									

Technical data – Valve width 20 mm

Code for position function 1-32		M	J	N	K	H	B	G	E	X	W	D	I	NS	KS	HS	DS
Switching times	On [ms]	15	9	8	8	8	11	10	11	13	13	7	7	12	12	12	12
	Off [ms]	28	–	28	28	28	46	40	47	22	22	25	23	25	25	25	25
	Change-over [ms]	–	22	–	–	–	23	21	23	–	–	–	–	–	–	–	–
Operating pressure [bar]	–0.9 ... +10		3 ... 10			–0.9 ... +10					3 ... 10		–0.9 ... +8				
Standard nominal flow rate [l/min]	870	860	610	550	550	550	750	700	480	480	840	850	620	500	550	820	
Design	Piston spool valve																
Materials	Die cast aluminium																

Technical data

Pneumatic connections		
Right-hand end plate		
Supply	1	Thread G1/4 (QS-G1/4, straight, for tubing O.D. 8 mm, 10 mm, 12 mm, 5/16", 3/8", 1/2")
Exhaust port	3 5	
Pilot air supply	12/14	Thread M7 (QSM-M7, straight or angled, for tubing O.D. 4 mm, 6 mm, 1/4")
Pilot exhaust air	82/84	
Supply module		
Supply	1	Cartridge fitting 20 mm (QSPKG20, straight, for tubing O.D. 8 mm, 10 mm, 12 mm, 5/16", 3/8", 1/2", adapter to thread G1/4), flat plate silencer
Exhaust port	3/5	
Sub-base width 10 mm		
Working ports	2 4	Cartridge fitting 10 mm (QSPKG10, straight or angled, for tubing O.D. 4 mm, 6 mm, 5/32", 1/4", adapter to thread M7)
Sub-base width 14 mm		
Working ports	2 4	Cartridge fitting 14 mm (QSPKG14, straight or angled, for tubing O.D. 6 mm, 8 mm, 1/4", 5/16", adapter to thread G1/8)
Sub-base width 20 mm		
Working ports	2 4	Cartridge fitting 18 mm (QSPKG18, straight or angled, for tubing O.D. 8 mm, 10 mm, 5/16", 3/8", adapter to thread G1/4)

Materials	
Sub-base	PA
Supply module	PPA
End plate	Die-cast aluminium, PA, PBT
Seals	NBR
Exhaust plate	PA
Flat plate silencer	PE
Electrical interlinking module	PBT, PA, copper alloy

Accessories

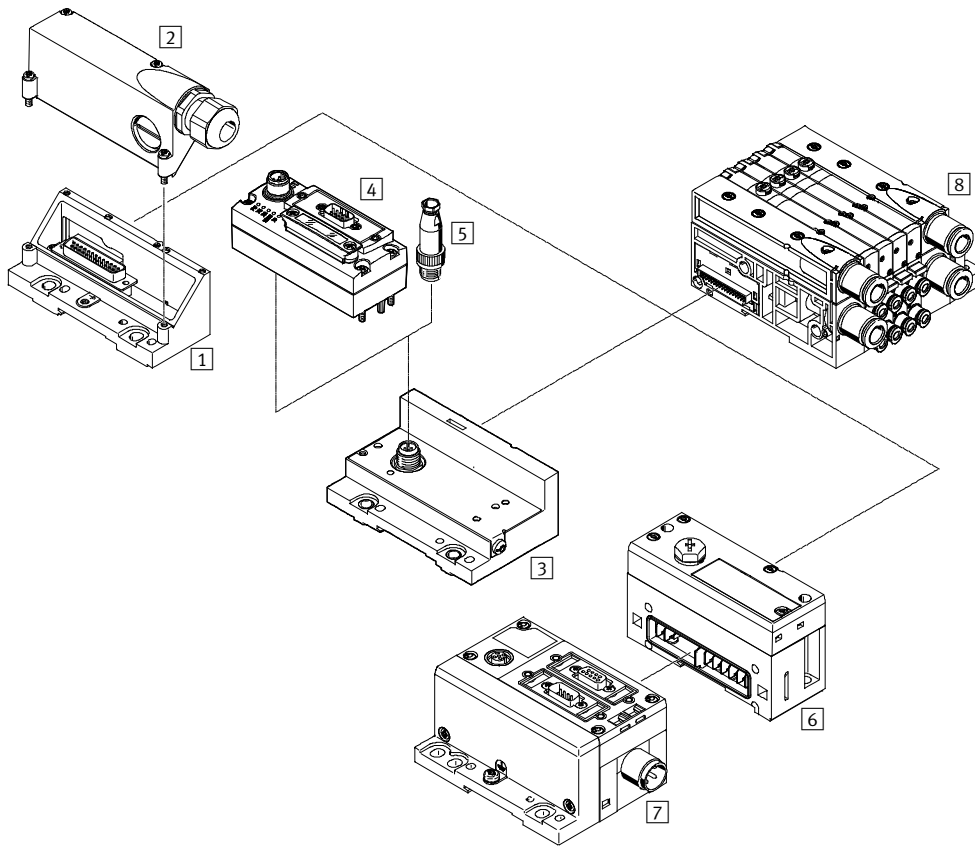

Accessories	→ Page/online
1 End plate VMPAL-EPL with multi-pin plug connection	669
2 Connecting cable VMPAL-KM for multi-pin plug connection	669
3 End plate VMPAL-EPL-IPO32 with I-Port interface/IO-Link	669
4 Fieldbus node CTEU	669
5 Plug SEA-M12 for I-Port interface/IO-Link	669
6 End plate VMPAL-EPL-CPX with pneumatic interface for CPX terminal	669
7 Module CPX for CPX terminal	677
8 Valve terminal, pneumatic part	668
- Cover plate VMPA1-RP for valve position	676
- Plug connector NECU-FCG40 for flat cable	676
- User documentation P,BE-MPA-L	676

Accessories

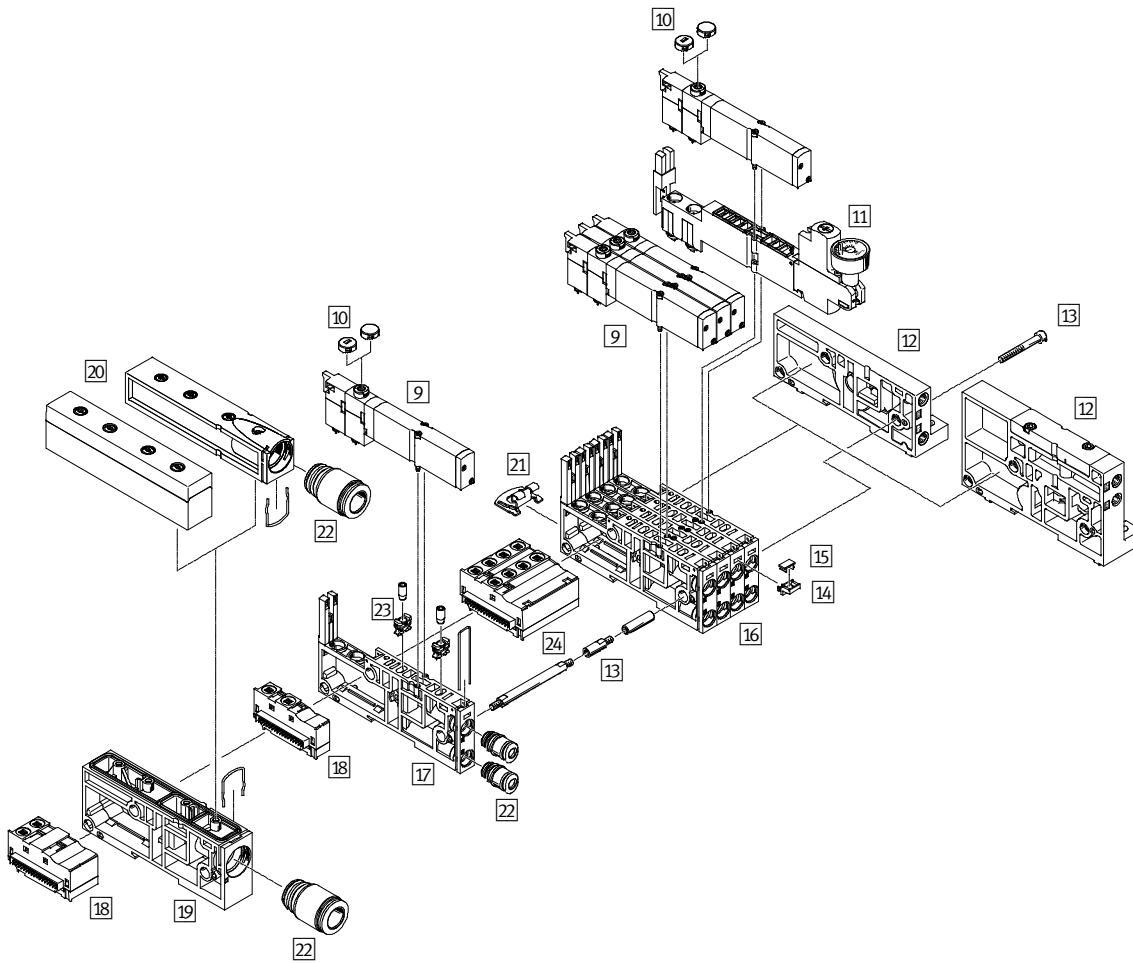

9

Accessories	→ Page/online
9 Solenoid valve VMPA	670
10 Cover VMPA-HB for manual override	671
11 Vertical stacking modules VMPA1-B8/VMPA2-B8	671
12 Right-hand end plate VMPAL-EPR, with pilot air selector for choosing the pilot air supply (internal or external)	671
13 Tie rod VMPAL-ZA	672
14 Inscription label holder VMPAL-ST-AP	672
15 Inscription label IBS-6x10	672
16 Sub-base VMPAL-AP-4X, 4 pieces combined	673
17 Sub-base VMPAL-AP	673
18 Electrical interlinking module VMPAL-EVAP	675
19 Supply module VMPAL-SP	675
20 Exhaust plate VMPA2-B8	675
21 Mounting VMPAL-BD	676
22 Cartridge fitting QSPKG	676
23 Fixed restrictor VMPA1-FT	mpa-l
24 Electrical interlinking module VMPAL-EVAP-4 for four sub-bases	mpa-l
- Cover plate VMPA1-RP for valve position	676
- Plug connector NECU-FCG40 for flat cable	676
- User documentation P.BE-MPA-L	676

Accessories – Ordering data

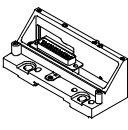
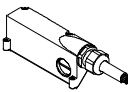
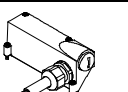
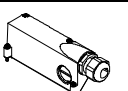
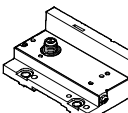
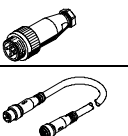
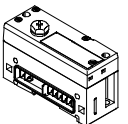
	Code ¹⁾	Description		Part No.	Type	
1 End plate with multi-pin plug connection						
	MS2	Sub-D, 9-pin, 8 addresses		570777	VMPAL-EPL-SD9-IP40	
	MS1	Sub-D, 25-pin, 24 addresses	★	560940	VMPAL-EPL-SD25-IP40	
	MS3	Sub-D, 44-pin, 32 addresses	★	560941	VMPAL-EPL-SD44-IP40	
	MF1	Flat cable, 40-pin, 32 addresses		560942	VMPAL-EPL-FL40-IP40	
	MC	Terminal strip, 33-pin, 32 addresses	★	560943	VMPAL-EPL-KL33-IP40	
	MS6	Sub-D, 25-pin, 24 addresses	★	560938	VMPAL-EPL-SD25	
	MS8	Sub-D, 44-pin, 32 addresses	★	560939	VMPAL-EPL-SD44	
2 Cover for multi-pin plug connection with Sub-D plug socket with connecting cable, cable outlet to front						
	CA	For left-hand end plate MS6, 25-pin	2.5 m	★	560416	VMPAL-KM-V-SD25-IP67-2,5
			5 m	★	560417	VMPAL-KM-V-SD25-IP67-5
			10 m		560418	VMPAL-KM-V-SD25-IP67-10
			0.5 ... 30 m		562389	VMPAL-KM-V-SD25-IP67-X
	CJ	For left-hand end plate MS8, 44-pin	2.5 m	★	560422	VMPAL-KM-V-SD44-IP67-2,5
			5 m	★	560423	VMPAL-KM-V-SD44-IP67-5
			10 m		560424	VMPAL-KM-V-SD44-IP67-10
			0.5 ... 30 m		562390	VMPAL-KM-V-SD44-IP67-X
With connecting cable, cable outlet to side						
	CD	For left-hand end plate MS6, 25-pin	2.5 m	★	560419	VMPAL-KM-S-SD25-IP67-2,5
			5 m		560420	VMPAL-KM-S-SD25-IP67-5
			10 m		560421	VMPAL-KM-S-SD25-IP67-10
			0.5 ... 30 m		562392	VMPAL-KM-S-SD25-IP67-X
	CM	For left-hand end plate MS8, 44-pin	2.5 m	★	560425	VMPAL-KM-S-SD44-IP67-2,5
			5 m		560426	VMPAL-KM-S-SD44-IP67-5
			10 m		560427	VMPAL-KM-S-SD44-IP67-10
			0.5 ... 30 m		562393	VMPAL-KM-S-SD44-IP67-X
Without connecting cable, cable outlet to side or front						
	EZ	For left-hand end plate MS6, 25-pin		560428	VMPAL-KM-SD25-IP67-0	
	EY	For left-hand end plate MS8, 44-pin		560429	VMPAL-KM-SD44-IP67-0	
3 End plate with I-Port interface/IO-Link						
	LK	Node with IO-Link	★	575667	VMPAL-EPL-IPO32	
	PT	Node with I-Port interface	★	575667	VMPAL-EPL-IPO32	
5 Plug for I-Port interface/IO-Link						
	–	Straight plug M12, 5-pin		175487	SEA-M12-5GS-PG7	
	–	Connecting cable	5 m		574321	NEBU-M12G5-E-5-Q8N-M12G5
			7.5 m		574322	NEBU-M12G5-E-7.5-Q8N-M12G5
			10 m		574323	NEBU-M12G5-E-10-Q8N-M12G5
6 End plate with pneumatic interface						
	CX	Pneumatic interface for CPX terminal, 32 addresses		570783	VMPAL-EPL-CPX	





1) Code letter within the order code for a valve terminal configuration

Accessories – Ordering data

	Code ¹⁾	Description		Part No.	Type
9 Solenoid valve, individual sub-base valve, width 10 mm					
	M	5/2-way valve, single solenoid	★	533342	VMPA1-M1H-M-PI
	MU	5/2-way valve, single solenoid, polymer poppet valve	★	553113	VMPA1-M1H-MU-PI
	J	5/2-way valve, double solenoid	★	533343	VMPA1-M1H-J-PI
	N	2x 3/2-way valve, normally open		533348	VMPA1-M1H-N-PI
	NS	2x 3/2-way valve, normally open, mechanical spring return		556839	VMPA1-M1H-NS-PI
	NU	2x 3/2-way valve, normally open, polymer poppet valve		553111	VMPA1-M1H-NU-PI
	W	1x 3/2-way valve, normally open, external compressed air supply		540050	VMPA1-M1H-W-PI
	K	2x 3/2-way valve, normally closed	★	533347	VMPA1-M1H-K-PI
	KS	2x 3/2-way valve, normally closed, mechanical spring return	★	556838	VMPA1-M1H-KS-PI
	KU	2x 3/2-way valve, normally closed, polymer poppet valve	★	553110	VMPA1-M1H-KU-PI
	H	2x 3/2-way valve, 1x normally open, 1x normally closed		533349	VMPA1-M1H-H-PI
	HS	2x 3/2-way valve, 1x normally open, 1x normally closed, mechanical spring return		556840	VMPA1-M1H-HS-PI
	HU	2x 3/2-way valve, 1x normally open, 1x normally closed, polymer poppet valve		553112	VMPA1-M1H-HU-PI
	B	5/3-way valve, mid-position pressurised		533344	VMPA1-M1H-B-PI
	G	5/3-way valve, mid-position closed	★	533345	VMPA1-M1H-G-PI
	E	5/3-way valve, mid-position exhausted		533346	VMPA1-M1H-E-PI
	X	1x 3/2-way valve, normally closed, external compressed air supply		534415	VMPA1-M1H-X-PI
	D	2x 2/2-way valve, normally closed		533350	VMPA1-M1H-D-PI
	DS	2x 2/2-way valve, normally closed, mechanical spring return		556841	VMPA1-M1H-DS-PI
I	2x 2/2-way valve, 1x normally closed and 1x normally closed, reversible		543605	VMPA1-M1H-I-PI	
Individual sub-base valve, width 14 mm					
	M	5/2-way valve, single solenoid	★	573718	VMPA14-M1H-M-PI
	J	5/2-way valve, double solenoid	★	573717	VMPA14-M1H-J-PI
	N	2x 3/2-way valve, normally open		573725	VMPA14-M1H-N-PI
	K	2x 3/2-way valve, normally closed	★	573724	VMPA14-M1H-K-PI
	H	2x 3/2-way valve, 1x normally open, 1x normally closed		573726	VMPA14-M1H-H-PI
	B	5/3-way valve, mid-position pressurised		573719	VMPA14-M1H-B-PI
	G	5/3-way valve, mid-position closed	★	573721	VMPA14-M1H-G-PI
	E	5/3-way valve, mid-position exhausted		573720	VMPA14-M1H-E-PI
D	2x 2/2-way valve, normally closed		573727	VMPA14-M1H-D-PI	

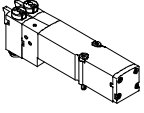
1) Code letter within the order code for a valve terminal configuration

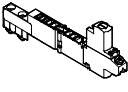
Accessories – Ordering data

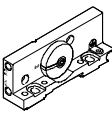
	Code ¹⁾	Description	Part No.	Type
9 Solenoid valve, individual sub-base valve, width 20 mm				
	M	5/2-way valve, single solenoid	★ 8022034	VMPA2-M1BH-M-PI
	J	5/2-way valve, double solenoid	★ 8022035	VMPA2-M1BH-J-PI
	N	2x 3/2-way valve, normally open	537958	VMPA2-M1H-N-PI
	NS	2x 3/2-way valve, normally open, mechanical spring return	568655	VMPA2-M1H-NS-PI
	W	1x 3/2-way valve, normally open, external compressed air supply	8022040	VMPA2-M1BH-W-PI
	K	2x 3/2-way valve, normally closed	★ 537957	VMPA2-M1H-K-PI
	KS	2x 3/2-way valve, normally closed, mechanical spring return	★ 568656	VMPA2-M1H-KS-PI
	H	2x 3/2-way valve, 1x normally open, 1x normally closed	537959	VMPA2-M1H-H-PI
	HS	2x 3/2-way valve, 1x normally open, 1x normally closed, mechanical spring return	568658	VMPA2-M1H-HS-PI
	B	5/3-way valve, mid-position pressurised	8022036	VMPA2-M1BH-B-PI
	G	5/3-way valve, mid-position closed	★ 8022037	VMPA2-M1BH-G-PI
	E	5/3-way valve, mid-position exhausted	8033038	VMPA2-M1BH-E-PI
	X	1x 3/2-way valve, normally closed, external compressed air supply	8022039	VMPA2-M1BH-X-PI
	D	2x 2/2-way valve, normally closed	537960	VMPA2-M1H-D-PI
	DS	2x 2/2-way valve, normally closed, mechanical spring return	568657	VMPA2-M1H-DS-PI
I	2x 2/2-way valve, 1x normally closed and 1x normally open, reversible	543703	VMPA2-M1H-I-PI	
10 Cover for manual override				
	N	Non-detenting (10 pieces)	540897	VMPA-HBT-B
	V	Covered (10 pieces)	540898	VMPA-HBV-B
11 Vertical stacking modules, regulator plate				
	PA	Width 10 mm	Port 1	564908 VMPA1-B8-R1-M5-10
	PC		Port 2	564909 VMPA1-B8-R2-M5-10
	PB		Port 4	564910 VMPA1-B8-R3-M5-10
	PA	Width 20 mm	Port 1	543342 VMPA2-B8-R1C2-C-10
	PC		Port 2	543343 VMPA2-B8-R2C2-C-10
	PB		Port 4	543344 VMPA2-B8-R3C2-C-10
Pressure gauge Technical data online: → pagn				
	VE	For regulator plate VMPA1	Display unit bar	132340 MA-15-10-M5
	VD		Display unit psi	132341 MA-15-145-M5-PSI
	T	For regulator plate VMPA2	With cartridge fitting connection for regulator plate code PA, PB, PC, PL, PK	543487 PAGN-26-16-P10
			With cartridge fitting connection for regulator plate code PF, PG, PH, PN, PM	543488 PAGN-26-10-P10
12 Right-hand end plate				
	-	Low; with ports 12/14, 82/84	★ 560945	VMPAL-EPR
	D	High; with ports 1, 3, 5, 12/14, 82/84; reverse operation possible	★ 560947	VMPAL-EPR-SP

1) Code letter within the order code for a valve terminal configuration

Accessories – Ordering data

	Code ¹⁾	Description		Part No.	Type	
13 Tie rod						
	-	Threaded rod for tie rod	Length 5 mm	★	561116	VMPAL-ZAS-5
			Length 45 mm	★	561117	VMPAL-ZAS-45
			Length 85 mm	★	561118	VMPAL-ZAS-85
			Length 125 mm	★	561119	VMPAL-ZAS-125
			Length 165 mm	★	561120	VMPAL-ZAS-165
			Length 205 mm	★	561121	VMPAL-ZAS-205
			Length 245 mm	★	561122	VMPAL-ZAS-245
			Length 285 mm	★	561123	VMPAL-ZAS-285
			Length 325 mm	★	561124	VMPAL-ZAS-325
			Length 365 mm	★	561125	VMPAL-ZAS-365
			Length 405 mm	★	561126	VMPAL-ZAS-405
			Length 445 mm	★	561127	VMPAL-ZAS-445
			Length 485 mm	★	561128	VMPAL-ZAS-485
Length 525 mm	★	561129	VMPAL-ZAS-525			
	-	Sleeve	Length 36 mm	★	561135	VMPAL-ZAH-36
			Length 46 mm	★	561136	VMPAL-ZAH-46
			Length 56 mm	★	561137	VMPAL-ZAH-56
			Length 66 mm	★	561138	VMPAL-ZAH-66
	-	Tie rod extender	For one sub-base in 10 mm width	★	561139	VMPAL-ZAE-10
			For one sub-base in 14 mm width	★	561140	VMPAL-ZAE-14
			For one sub-base in 20 mm width		561141	VMPAL-ZAE-20
			For four sub-bases in 10 mm width	★	570779	VMPAL-ZAE-10-4
			For one supply module	★	561141	VMPAL-ZAE-20
	-	Screw, 3 pieces, M4x30 mm, for tie rod	★	571924	VMPAL-M-4x30	
		Screw, 10 pieces, M4x10 mm and nut with internal hex 2.5 mm, for linking four sub-bases	★	561142	VMPAL-MS-4x10	
14 Inscription label holder						
	TM	For sub-base	Width 10 mm	★	561109	VMPAL-ST-AP-10
			Width 14 mm	★	561112	VMPAL-ST-AP-14
			Width 20 mm	★	561115	VMPAL-ST-AP-20
15 Inscription label						
	-	6 mm x 10 mm, 64 pieces in frame		18576	IBS-6x10	

1) Code letter within the order code for a valve terminal configuration

Accessories – Ordering data

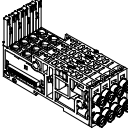
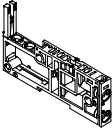
	Code ¹⁾	Description		Part No.	Type
16 Sub-base, 4 pieces combined, width 10 mm					
	Without electrical interlinking module				
	–	Without cartridge fitting	–	★ 560981	VMPAL-AP-4X10
	With electrical interlinking module for single solenoid valves				
	–	With cartridge fitting for tubing O.D.	4 mm	561089	VMPAL-AP-4X10-QS4-1
			6 mm	561083	VMPAL-AP-4X10-QS6-1
			5/32"	561101	VMPAL-AP-4X10-QS5/32"-1
			1/4"	561095	VMPAL-AP-4X10-QS1/4"-1
	With electrical interlinking module for double solenoid valves				
	–	With cartridge fitting for tubing O.D.	4 mm	561090	VMPAL-AP-4X10-QS4-2
			6 mm	561084	VMPAL-AP-4X10-QS6-2
			5/32"	561102	VMPAL-AP-4X10-QS5/32"-2
			1/4"	561096	VMPAL-AP-4X10-QS1/4"-2
17 Sub-base, width 10 mm					
	Without electrical interlinking module, without cartridge fitting				
	–	No duct separation		★ 554311	VMPAL-AP-10
	T	Duct 1 separated		★ 554312	VMPAL-AP-10-T1
	TR	Duct 3, 5 separated		★ 554313	VMPAL-AP-10-T35
	TS	Duct 1 and 3, 5 separated		★ 554315	VMPAL-AP-10-T135
	With electrical interlinking module for single solenoid valves				
	–	With cartridge fitting for tubing O.D.	4 mm	★ 560994	VMPAL-AP-10-QS4-1
			6 mm	★ 560987	VMPAL-AP-10-QS6-1
			5/32"	561005	VMPAL-AP-10-QS5/32"-1
			1/4"	560999	VMPAL-AP-10-QS1/4"-1
	With electrical interlinking module for double solenoid valves				
	–	With cartridge fitting for tubing O.D.	4 mm	★ 560988	VMPAL-AP-10-QS4-2
			6 mm	★ 560993	VMPAL-AP-10-QS6-2
			5/32"	561006	VMPAL-AP-10-QS5/32"-2
			1/4"	561000	VMPAL-AP-10-QS1/4"-2
	With electrical interlinking module for single solenoid valves, duct 1 separated				
	–	With cartridge fitting for tubing O.D.	4 mm	★ 561017	VMPAL-AP-10-QS4-1-T1
			6 mm	★ 561011	VMPAL-AP-10-QS6-1-T1
			5/32"	561029	VMPAL-AP-10-QS5/32"-1-T1
			1/4"	561023	VMPAL-AP-10-QS1/4"-1-T1
	With electrical interlinking module for double solenoid valves, duct 1 separated				
	–	With cartridge fitting for tubing O.D.	4 mm	★ 561018	VMPAL-AP-10-QS4-2-T1
	6 mm		★ 561012	VMPAL-AP-10-QS6-2-T1	
	5/32"		561030	VMPAL-AP-10-QS5/32"-2-T1	
	1/4"		561024	VMPAL-AP-10-QS1/4"-2-T1	

1) Code letter within the order code for a valve terminal configuration

Accessories – Ordering data

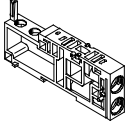
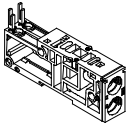
	Code ¹⁾	Description		Part No.	Type	
	Sub-base, width 14 mm					
	Without electrical interlinking module, without cartridge fitting					
	-	No duct separation	★	560973	VMPAL-AP-14	
	T	Duct 1 separated	★	560975	VMPAL-AP-14-T1	
	TR	Duct 3, 5 separated	★	560977	VMPAL-AP-14-T35	
	TS	Duct 1 and 3, 5 separated	★	560979	VMPAL-AP-14-T135	
	With electrical interlinking module for single solenoid valves					
	-	With cartridge fitting for tubing O.D.	6 mm	★	560995	VMPAL-AP-14-QS6-1
			8 mm	★	560989	VMPAL-AP-14-QS8-1
			1/4"		561007	VMPAL-AP-14-QS1/4"-1
			5/16"		561001	VMPAL-AP-14-QS5/16"-1
	With electrical interlinking module for double solenoid valves					
	-	With cartridge fitting for tubing O.D.	6 mm	★	560996	VMPAL-AP-14-QS6-2
			8 mm	★	560990	VMPAL-AP-14-QS8-2
			1/4"		561008	VMPAL-AP-14-QS1/4"-2
			5/16"		561002	VMPAL-AP-14-QS5/16"-2
	With electrical interlinking module for single solenoid valves, duct 1 separated					
	-	With cartridge fitting for tubing O.D.	6 mm		561019	VMPAL-AP-14-QS6-1-T1
			8 mm	★	561013	VMPAL-AP-14-QS8-1-T1
			1/4"		561031	VMPAL-AP-14-QS1/4"-1-T1
			5/16"		561025	VMPAL-AP-14-QS5/16"-1-T1
	With electrical interlinking module for double solenoid valves, duct 1 separated					
	-	With cartridge fitting for tubing O.D.	6 mm		561020	VMPAL-AP-14-QS6-2-T1
			8 mm	★	561014	VMPAL-AP-14-QS8-2-T1
			1/4"		561032	VMPAL-AP-14-QS1/4"-2-T1
			5/16"		561026	VMPAL-AP-14-QS5/16"-2-T1
	Width 20 mm					
		Without electrical interlinking module, without cartridge fitting				
-		No duct separation	★	560974	VMPAL-AP-20	
T		Duct 1 separated	★	560976	VMPAL-AP-20-T1	
TR		Duct 3, 5 separated	★	560978	VMPAL-AP-20-T35	
TS		Duct 1 and 3, 5 separated	★	560980	VMPAL-AP-20-T135	
With electrical interlinking module for single solenoid valves						
-		With cartridge fitting for tubing O.D.	8 mm		560997	VMPAL-AP-20-QS8-1
			10 mm	★	560991	VMPAL-AP-20-QS10-1
			5/16"		561009	VMPAL-AP-20-QS5/16"-1
			3/8"		561003	VMPAL-AP-20-QS3/8"-1
With electrical interlinking module for double solenoid valves						
-		With cartridge fitting for tubing O.D.	8 mm		560998	VMPAL-AP-20-QS8-2
			10 mm	★	560992	VMPAL-AP-20-QS10-2
			5/16"		561010	VMPAL-AP-20-QS5/16"-2
			3/8"		561004	VMPAL-AP-20-QS3/8"-2
With electrical interlinking module for single solenoid valves, duct 1 separated						
-		With cartridge fitting for tubing O.D.	8 mm		561021	VMPAL-AP-20-QS8-1-T1
			10 mm		561015	VMPAL-AP-20-QS10-1-T1
			5/16"		561033	VMPAL-AP-20-QS5/16"-1-T1
			3/8"		561027	VMPAL-AP-20-QS3/8"-1-T1
With electrical interlinking module for double solenoid valves, duct 1 separated						
-		With cartridge fitting for tubing O.D.	8 mm		561022	VMPAL-AP-20-QS8-2-T1
			10 mm		561016	VMPAL-AP-20-QS10-2-T1
			5/16"		561034	VMPAL-AP-20-QS5/16"-2-T1
			3/8"		561028	VMPAL-AP-20-QS3/8"-2-T1





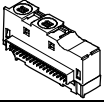
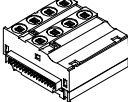
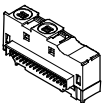
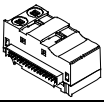
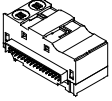
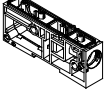
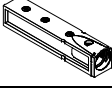
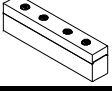

1) Code letter within the order code for a valve terminal configuration

Accessories – Ordering data

	Code ¹⁾	Description		Part No.	Type	
18 Electrical interlinking module						
for one sub-base in 10 mm width						
	C	Grey – single solenoid (1 solenoid coil)	★	560961	VMPAL-EVAP-10-1	
	A	Black – double solenoid (2 solenoid coils)	★	560962	VMPAL-EVAP-10-2	
For combination of four sub-bases in 10 mm width						
	C	Grey – single solenoid (4 solenoid coils)	★	560967	VMPAL-EVAP-10-1-4	
	A	Black – double solenoid (8 solenoid coils)	★	560968	VMPAL-EVAP-10-2-4	
For one sub-base in 14 mm width						
	C	Grey – single solenoid (1 solenoid coil)	★	560963	VMPAL-EVAP-14-1	
	A	Black – double solenoid (2 solenoid coils)	★	560964	VMPAL-EVAP-14-2	
For one sub-base in 20 mm width						
	C	Grey – single solenoid (1 solenoid coil)	★	560965	VMPAL-EVAP-20-1	
	A	Black – double solenoid (2 solenoid coils)	★	560966	VMPAL-EVAP-20-2	
For supply module (signals are passed through)						
	U	Black	★	571011	VMPAL-EVAP-20-SP	
19 Supply module						
	Without electrical interlinking module					
	U	Without cartridge fitting	★	570774	VMPAL-SP	
	With electrical interlinking module					
	–	Without cartridge fitting	–	★	560950	VMPAL-SP-0
		With cartridge fitting for tubing O.D.	8 mm	★	573645	VMPAL-SP-QS8
			10 mm	★	560951	VMPAL-SP-QS10
			12 mm		560952	VMPAL-SP-QS12
			5/16"		573646	VMPAL-SP-QS5/16"
			3/8"		560953	VMPAL-SP-QS3/8"
	1/2"		560954	VMPAL-SP-QS1/2"		
6 Exhaust plate						
For ducted exhaust air						
	–	Without cartridge fitting	★	560956	VMPAL-EG	
		With cartridge fitting for tubing O.D.	10 mm		560957	VMPAL-EG-QS10
			3/8"		560959	VMPAL-EG-QS3/8"
For unducted exhaust air						
	–	Flat plate silencer	★	560955	VMPAL-EU	

1) Code letter within the order code for a valve terminal configuration

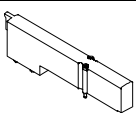
Accessories – Ordering data

	Code ¹⁾	Description	Part No.	Type	
21 Mounting					
	-	Mounting bracket (should be installed max. every 13 cm)	560949	VMPAL-BD	
	H	H-rail mounting for MPA-L with multi-pin plug connection	★ 526032	CPX-CPA-BG-NRH	
	H	H-rail mounting for MPA-L with fieldbus connection	560798	VMPAF-FB-BG-NRH	
22 Cartridge fitting Technical data online: → qsp					
	-	10 mm cartridge fitting, plastic, for working ports, 10 pieces, connection for tubing O.D.	4 mm	132622	QSPKG10-4
			6 mm	132623	QSPKG10-6
			3/16"	132625	QSPKG10-3/16-U
			1/4"	132626	QSPKG10-1/4-U
	-	14 mm cartridge fitting, plastic, for supply ports, 10 pieces, connection for tubing O.D.	6 mm	132930	QSPKG14-6
			8 mm	132931	QSPKG14-8
			1/4"	132932	QSPKG14-1/4-U
	-	18 mm cartridge fitting, plastic, for supply ports, 10 pieces, connection for tubing O.D.	5/16"	132933	QSPKG14-5/16-U
			8 mm	132649	QSPKG18-8
			10 mm	132650	QSPKG18-10
	-	20 mm cartridge fitting, plastic, for supply ports, 10 pieces, connection for tubing O.D.	5/16"	132651	QSPKG18-5/16-U
			3/8"	132652	QSPKG18-3/8-U
			10 mm	132634	QSPKG20-10
	AGG	Adapter for 10 mm cartridge fitting connection to thread M7, 10 pieces	★ 572380	VMPAL-F10-M7	
	BGG	Adapter for 14 mm cartridge fitting connection to thread G1/8, 10 pieces	574084	VMPAL-F14-G1/8	
	CGG	Adapter for 18 mm cartridge fitting connection to thread G1/4, 10 pieces	573914	VMPAL-F20-G1/4	
	-	Adapter for 20 mm cartridge fitting connection to thread G1/4, 10 pieces	★ 572381	VMPAL-FSP-G1/4	
Blanking plate for vacant valve position					
	L	Self-adhesive label supplied	For size MPA1	533351	VMPA1-RP
			For size MPA14	★ 573729	VMPA14-RP
			For size MPA2	537962	VMPA2-RP
Plug connector for flat cable					
	-	Pre-assembled plug connector, 40-pin, cable cross section 0.08 ... 0.13 mm ²	570895	NECU-FCG40-K	
User documentation					
	DE	German	556353	P.BE-MPAL-DE	
	EN	English	556354	P.BE-MPAL-EN	
	FR	French	556356	P.BE-MPAL-FR	
	IT	Italian	556357	P.BE-MPAL-IT	
	ES	Spanish	556355	P.BE-MPAL-ES	
	SV	Swedish	556358	P.BE-MPAL-SV	

1) Code letter within the order code for a valve terminal configuration



- Open to all leading fieldbus protocols/Industrial Ethernet with integrated IT services such as SMS/e-mail alert, web monitor
- Unique modular structure
- Comprehensive integrated diagnostic and maintenance functions
- CPX as a dedicated remote I/O
- CPX controls valve terminal MPA-S, MPA-L, VTSA
- Can be programmed with integrated controller

→ www.festo.com/catalogue/cpx

Product range overview

Type	Designation	Code ¹⁾	Address space		Version		→ Page/ online
			Inputs	Outputs	Plastic	Metal	
CPX-FEC-1-IE	Front End Controller Remote	T03	512 bit	512 bit	■	–	688
CPX-FEC-1-IE	Front End Controller Remote I/O	T05	512 bit	512 bit	■	–	cpx
CPX-CEC	CoDeSys Embedded Controller	T06, T07, T08	512 bit	512 bit	■	–	689
CPX-FB6	Bus node for INTERBUS	F06	96 bit	96 bit	■	–	690
CPX-FB11	Bus node for DeviceNet	F11	512 bit	512 bit	■	–	690
CPX-FB13	Bus node for PROFIBUS DP	F13	512 bit	512 bit	■	–	691
CPX-FB14	Bus node for CANopen	F14	256 bit	256 bit	■	–	691
CPX-FB20	Bus node for INTERBUS, fibre-optic connection	F20	96 bit	96 bit	–	■	cpx
CPX-FB21	Bus node for INTERBUS, fibre-optic connection	F21	96 bit	96 bit	–	■	cpx
CPX-FB23-24	Bus node for CC-Link	F23	256 bit	256 bit	■	–	692
		F24	512 bit	512 bit	■	–	692
CPX-FB32	Bus node for Ethernet/IP	F32	128 bit	128 bit	■	–	692
CPX-FB33	Bus node for PROFINET RT, 2 x M12	F33	512 bit	512 bit	–	■	693
CPX-M-FB34	Bus node for PROFINET RT, 2 x RJ45	F34	512 bit	512 bit	–	■	693
CPX-M-FB35	Bus node for PROFINET RT, 2 x SCRJ push-pull, AIDA	F35	512 bit	512 bit	–	■	694
CPX-FB38	Bus node for EtherCAT	F38	512 bit	512 bit	■	–	694

1) Code letter within the order code for a valve terminal configuration

Note

The electrical terminal can be ordered quickly and easily online.
The convenient product configurator can be found at:

→ www.festo.com/catalogue/cpx

Note

The bus node and control block provide the aforementioned address space.

Product range overview

Type	Designation	Code ¹⁾	Address space		Version		→ Page/ online
			Inputs	Outputs	Plastic	Metal	
CPX-CP-4-FB	CP interface	T11 ... T18	16 ... 128 bit	16 ... 128 bit	■	–	695
CPX-CTEL-4-M12-5POL	CPX-CTEL master	T40 ... T44	0 ... 256 bit	0 ... 256 bit	■	–	695
CPX-CMPX	End-position controller CMPX	T20	48 bit	48 bit	■	–	cmpx
CPX-CMAX	Axis controller CMAX	T21	64 bit	64 bit	■	–	cmax
CPX-CMIX	Measuring module CMIX	T23	48 bit	48 bit	■	–	cpx
CPX-CMXX	Multi-axis controller CMXX	T30	128 bit	128 bit	■	–	cmxx
CPX-CM-HPP	FHPP gateway	T31	256 bit	256 bit	■	–	696
CPX-4DE	Input module, 4 digital inputs	F	4/8 bit ²⁾	–	■	–	cpx
CPX-8DE	Input module, 8 digital inputs	E	8 bit	–	■	–	696
CPX-8DE-D	Input module, 8 digital inputs (channel diagnostics)	D	8 bit	–	■	–	cpx
CPX-8NDE	Input module, 8 digital inputs (NPN)	O	8 bit	–	■	–	696
CPX-16DE	Input module, 16 digital inputs	M	16 bit	–	■	–	697
CPX-M-16DE-D	Input module, 16 digital inputs (channel diagnostics)	NM	16 bit	–	■	–	697
CPX-L-16DE-16-KL-3POL	Input module, 16 digital inputs (spring-loaded terminal)	NB	16 bit	–	■	–	697
CPX-4DA	Output module, 4 digital outputs	C	–	4/8 bit ²⁾	■	–	697
CPX-8DA	Output module, 8 digital outputs	L	–	8 bit	■	–	cpx
CPX-8DA-H	Output module, 8 digital outputs (high current)	NL	–	8 bit	■	–	698
CPX-8DE-8DA	Input/output module, 16-way, 8 digital I/O each	Y	8 bit	8 bit	■	–	699
CPX-L-8DE-8DA-16-KL-3POL	Input module, 8 digital inputs/outputs (spring-loaded terminal)	NC	8 bit	8 bit	■	–	697
CPX-2AE-U-I	Input module, 2 analogue inputs	U	32 bit	–	■	–	700
CPX-4AE-U-I	Input module, 4 analogue inputs	NI	64 bit	–	■	–	cpx
CPX-4AE-I	Input module, 4 analogue inputs (current)	I	64 bit	–	■	–	701
CPX-4AE-T	Input module, 4 analogue inputs (temperature)	T	64 bit	–	■	–	702
CPX-4AE-TC	Input module, 4 analogue inputs (temperature, thermoelements)	NT	64 bit	–	■	–	703
CPX-4AE-P	Input module, 4 analogue inputs (pressure)	NY, NV	64 bit	–	■	–	704
CPX-2AA-U-I	Output module, 2 analogue outputs	P	–	32 bit	■	–	705
CPX-FVDA-P	PROFIsafe shut-off module	NF	48 bit	48 bit	–	■	706
CPX-FVDA-P2	PROFIsafe shut-off module	NG	48 bit	48 bit	–	■	706
CPX-GP-03-4,0	Pneumatic interface to Midi/Maxi	–A	–	8 ... 32 bit	■	–	cpx
CPX-M-GP-03-4,0		–A	–	8 ... 32 bit	–	■	cpx
VMPA-FB-EPL	Pneumatic interface to MPA-S	–D	16 ... 512 bit	4 ... 512 bit	■	■	709
VMPAF-FB-EPL	Pneumatic interface to MPA-F	–F	16 ... 512 bit	4 ... 512 bit	■	■	cpx
VMPAL-EPL-CPX	Pneumatic interface to MPA-L	–L	–	4 ... 32 bit	■	–	709
VABA-S6-1-X	Pneumatic interface to VTSA and VTSA-F	–S	–	8 ... 32 bit	■	■	710
CPX-GP-CPA	Pneumatic interface to CPA	–B, –C	–	8 ... 24 bit	■	–	cpx

1) Code letter within the order code for a valve terminal configuration

2) Number of occupied bits is dependent on the upstream bus node/control block

Note

The electrical terminal can be ordered quickly and easily online.
The convenient product configurator can be found at:

→ www.festo.com/catalogue/cpx

Note

Input/output modules, etc. use the specified address space.

Key features

Installation concept

- Choice of several valve terminal types for different applications:
 - MIDI/MAXI
 - CPA
 - MPA-S
 - MPA-F
 - MPA-L
 - MPA/MPA-F
 - VTSA/VTSA-F
- Economical from the smallest configuration up to the maximum number of modules
- Up to 9 electrical input/output modules plus bus nodes and pneumatic interface/electronics modules for valves
- Extensive range of functions and connection options for the electrical modules
- Choice of connection technology for technically and economically optimised connections
- Can be used as a dedicated remote I/O module

Electrics

- High operating voltage tolerance ($\pm 25\%$)
- Choice of M18, 7/8" or AIDA push-pull connection for power supply
- Open to all fieldbus protocols and Ethernet
- Optional function and technology modules for pre-processing
- IT services and TCP/IP such as remote maintenance, remote diagnostics, web server, SMS and e-mail alert
- Digital inputs and outputs, 4-way/8-way/16-way, optionally available with individual channel diagnostics
- Analogue inputs and outputs, 2-way/4-way
- Supply ports
- Temperature inputs
- Controllers for pneumatic and electric axes
- IP65 and IP67 or IP20

Mounting

- Wall or H-rail mounting, also on mobile units
- Conversions/extensions are possible at any time, individual linking with CPX metal design
- Modular system offering a range of configuration options
- Fully assembled and tested unit
- Lower costs for selection, ordering, assembly and commissioning thanks to the central CPX terminal
- Choice of pneumatic components for optimised control loop system design
- Decentralised, subordinate CPI installation system improves cycle times by up to 30%
- Safe and convenient earthing thanks to earthing plate

Operation

- Fast troubleshooting thanks to an extensive selection of LEDs (some of which are multi-coloured) on the bus node and on all I/O modules
- Suitable for direct machine mounting (IP65/IP67) or in a control cabinet with a terminal connection (IP20)
- Supports module and channel-oriented diagnostics
- On-the-spot diagnostics in plain text via handheld device
- Fieldbus/Ethernet remote diagnostics
- Innovative diagnostic support with integrated web server/web monitor or maintenance tool with USB adapter for PC
- Optimised commissioning thanks to parameterisable functions
- Reliability of service with connection blocks and modules that are quick to replace without changing the wiring

Pneumatic variants of the CPX terminal

The electrical CPX terminal is a modular peripheral system for valve terminals. The system is specifically designed so

that the valve terminal can be adapted to suit different applications.

The modular system design lets you configure the number of valves, inputs

and additional outputs to suit the application.

With valve terminal – decentralised

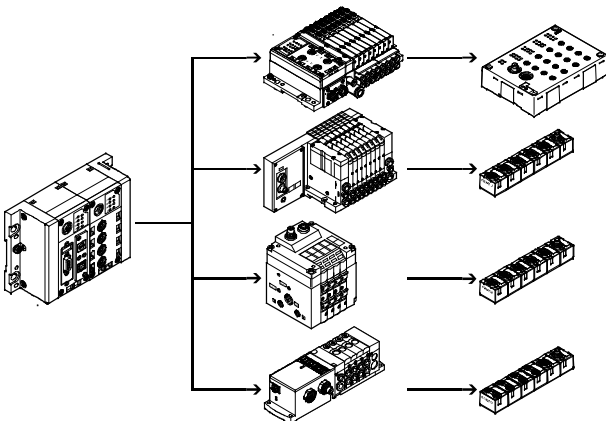

With valve terminal MPA-S – centralised

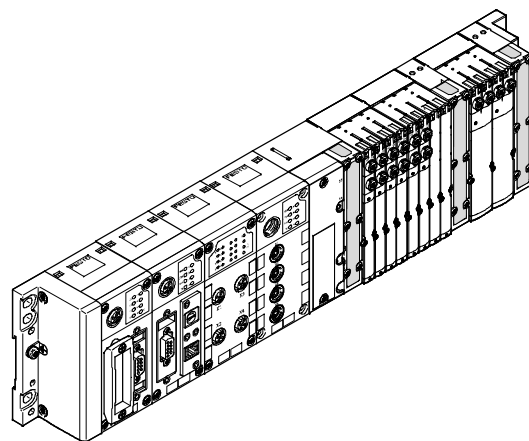

Variants

Complete overview of modules

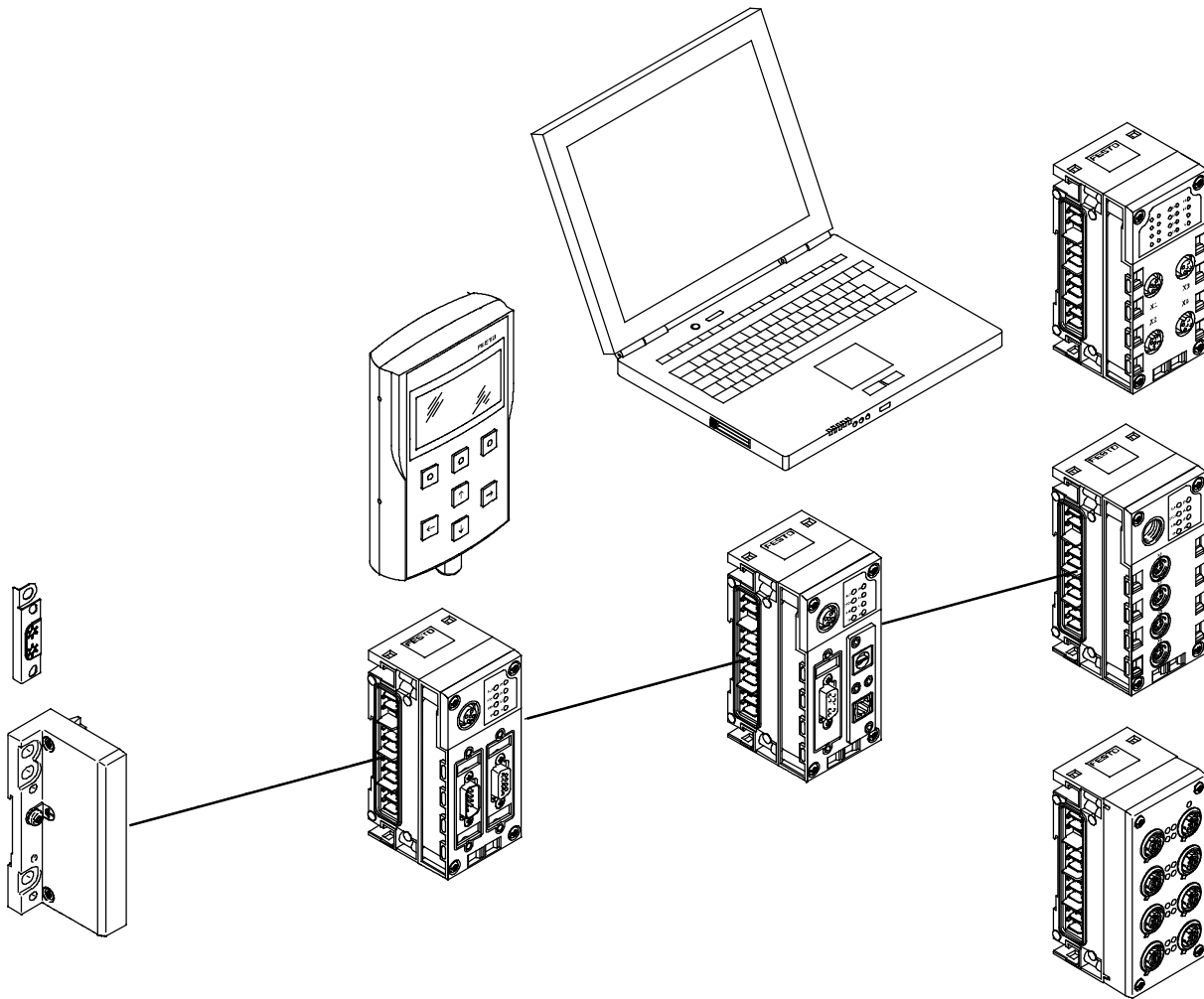
**End plate**

- Mounting holes for wall mounting
- Functional earth connection
- Special earthing plate for safe and easy connection to the machine bed or H-rail

Bus node

- Fieldbus/Industrial Ethernet connection using various types of connection technology
- Setting of fieldbus parameters via DIL switch
- Display of fieldbus and peripheral equipment status via LED
- PROFINET to AIDA standard in metal housing, fast start-up

Operator unit

- Connection to bus nodes or control block
- Display and modification of parameter settings
- Plain-text display for texts, messages (e.g. individual channel diagnostics, condition monitoring), menus, etc.

Control block

- Pre-processing, stand-alone controller or remote unit CPX-FEC-1-IE/CPX-CEC
- Connection via Ethernet TCP/IP or Sub-D programming interface
- Setting of operating modes via DIL switch and program selection via rotary switch
- CPX-CMX products for controlling axes

Web monitor

- Website integrated in the CPX terminal
- Dynamic status display
- Online diagnostics
- SMS/e-mail alert

CP interface/CTEL interface

- Interfaces for decentralised installation systems, thus optimising the pneumatic control chains (short tubes/short cycle times)
- Actuator for I/O modules and valve terminals
- Power supply and bus interface via the same cable

Input/output modules

- Combination of
- Interlinking block
 - Electronics module
 - Connection block

Variants

Complete overview of modules

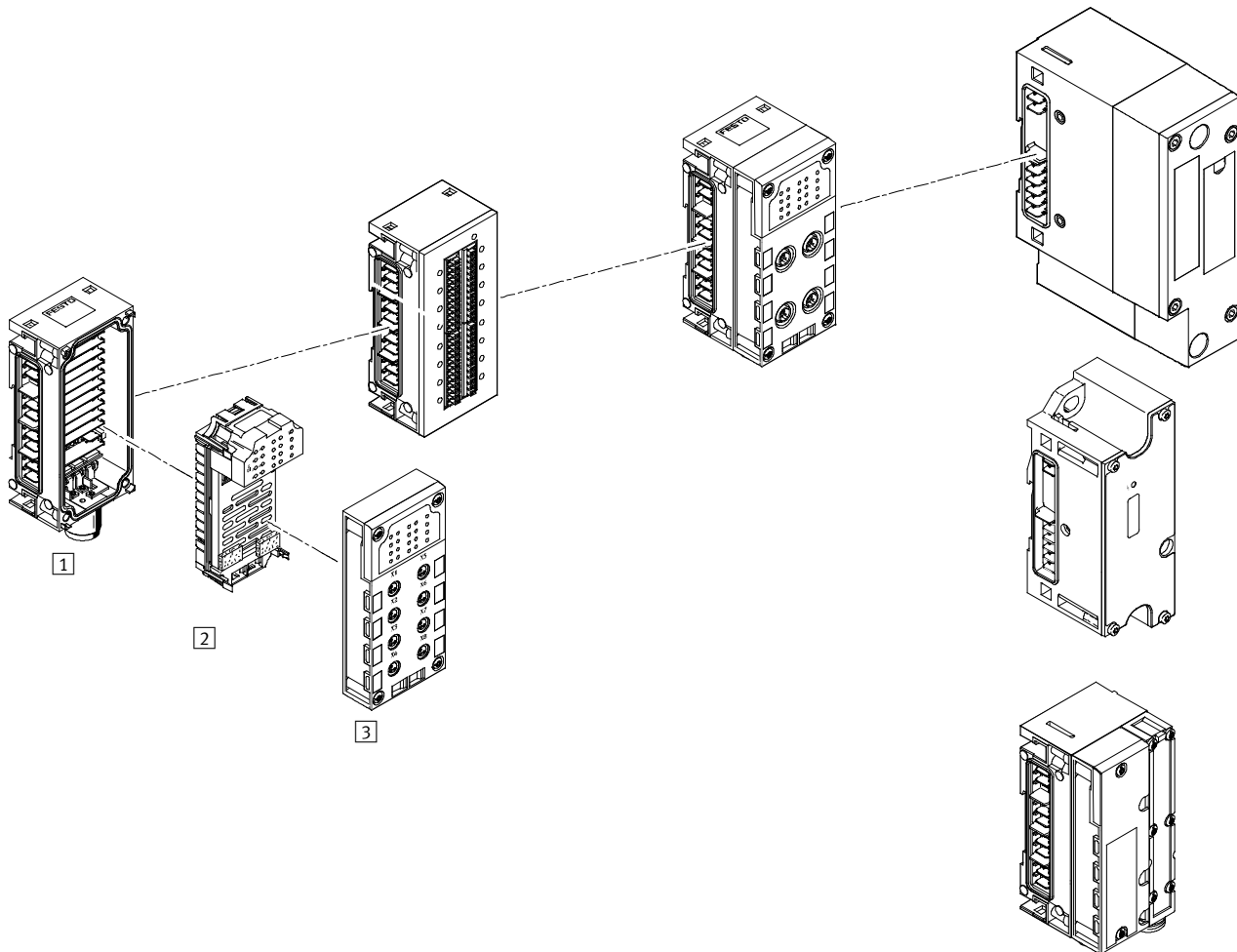

Input/output modules

1 Interlinking block

- Internal linking of the power supply and serial communication
- External power supply for the entire system
- Additional power supply for outputs or valves
- Connection accessories for M18, 7/8" or AIDA push-pull
- Plastic design: linking with tie rods
- Metal design: individual linking with M6 screws, individually expandable

2 Electronics module

- Digital inputs for connecting the sensors
- Digital outputs for activating additional actuators
- Analogue inputs
- Temperature inputs (analogue)
- Analogue outputs
- PROFI-safe shut-off module with two digital outputs for shutting off the supply voltage for valves

3 Connection block

- Choice of 8 connection technology variants
- Protection class IP65/IP67 or IP20
- Can be combined with the electronics modules
- M8/M12/Sub-D/quick connection accessories
- M8/M12/Sub-D, etc. connecting cables
- Modular system for M8/M12 connecting cables
- M12 connection technology for the metal design

Pneumatic interface

- Actuation of the solenoid coils
- MPA-S
- MPA-L
- VTSA/VTSA-F
- Actuation of pressure sensors
- Actuation of proportional pressure regulators

Variants

Individual overview of modules

Control block

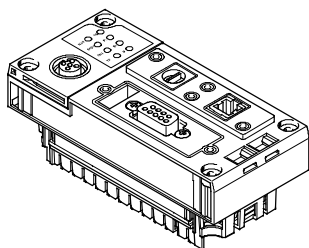

Technical data → 688 ff.

- CPX-FEC-1-IE
- Programming with FST
 - Ethernet interface
 - Modbus/TCP
 - EasyIP
 - Integrated web server
 - Sub-D programming interface

Bus node

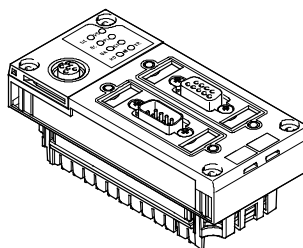

Technical data → 692 ff.

- Bus node for
- INTERBUS
 - DeviceNet
 - PROFIBUS DP
 - CANopen
 - CC-LINK
 - Ethernet/IP (integrated web server)
 - PROFINET (integrated web server)
 - EtherCAT

CP interface

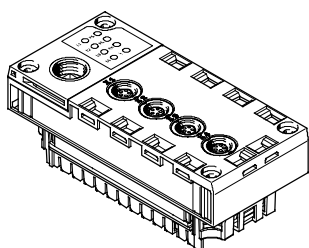

Technical data → 695

- CP interface
- 4 CP strings
 - Max. 4 modules per string
 - 321/320 per string
 - CPI functionality

CTEL interface

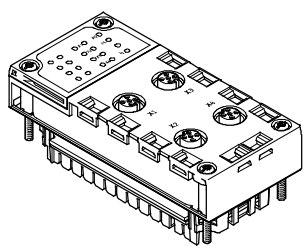

Technical data → 695

- CPX-CTEL interface
- CTETL master
 - Max. 4 devices with individual electronic fuse protection
 - Max. 64 inputs/64 outputs per I-Port interface
 - The maximum length of a string is 20 m

9

Modules for actuating electric drive units

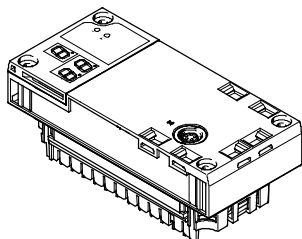

Technical data → 696

- CPX-CM-HPP
- Axis interface
 - CAN bus for up to 4 individual electric axes

Plastic connection block

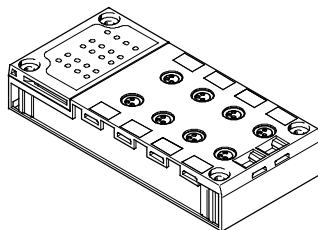

Metal connection block

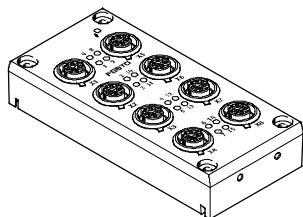

- Direct machine mounting (protection class IP65/IP67)
- M8 3-pin or 4-pin
 - M12 5-pin, 5-pin with quick lock/ metal thread screened, 8-pin, optional screening plate
 - Sub-D
 - Quick connection
 - Spring-loaded terminal with protection to IP20 or with cover

- Direct machine mounting (protection class IP65/IP67)
- M12 5-pin

Variants

Individual overview of modules

Digital electronics module

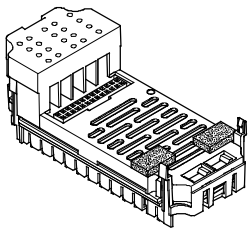

Technical data → 696 ff.

Digital inputs and outputs

- 8 digital inputs NPN
- 8 digital inputs PNP
- 16 digital inputs
- 16 digital inputs with channel diagnostics
- 4 digital outputs (1 A per channel, individual channel diagnostics)
- 8 digital outputs (2.1 A/50 W lamp load per channel pair, individual channel diagnostics)

Multi I/O modules

- 8 digital inputs and 8 digital outputs

Analogue electronics module

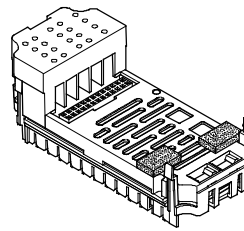

Technical data → 700 ff.

Analogue inputs

- 2 analogue inputs (0 ... 10 V DC, 0 ... 20 mA, 4 ... 20 mA)
- 4 analogue inputs (0 ... 20 mA, 4 ... 20 mA)

Analogue temperature inputs

- 4 analogue inputs for temperature measurement (Pt100, Pt200, Pt500, Pt1000, Ni100, Ni120, Ni500, Ni1000)
- 4 analogue inputs for temperature measurement (thermocoupler and PT1000 sensor for cold-junction compensation)

Analogue outputs

- 2 analogue outputs (0 ... 10 V DC, 0 ... 20 mA, 4 ... 20 mA)

PROFIsafe shut-off module

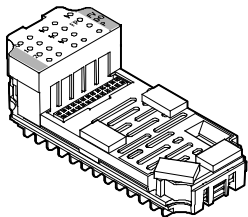

Technical data → 706

Digital outputs

- 2 digital outputs
- Supply voltage for valves can be shut off

Electronics module for supply ports

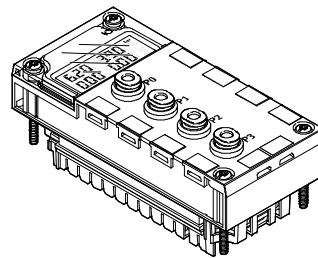

Technical data → 704

Analogue inputs

- 4 analogue supply ports (0 ... 10 bar, -1 ... +1 bar)

Plastic interlinking block – Interlinking by means of tie rods

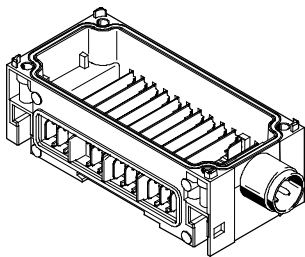

System linking

- Different voltages for supplying the modules
- Serial communication between the modules

System supply

- M18 4-pin
- 7/8" 4-pin or 5-pin

In addition to system interlinking, power supply for the

- electronics plus sensors (16 A)
- valves plus actuators (16 A)

Additional power supply

In addition to system linking, power supply for the

- actuators (16 A per supply)

Power supply for the

- valves (16 A per supply)

Expandability

- Can be expanded using an interlinking block with tie-rod extension CPX-ZA-1-E

Technical data → 707 ff.

Note

The 7/8" supply is subject to the following restriction due to the available accessories:

- 5-pin 8 A
- 4-pin 10 A

Note

Plastic interlinking blocks (tie rods) and metal interlinking blocks (individual linking) cannot be combined due to their different interlinking systems.

Variants

Individual overview of modules

Metal interlinking block – Individual linking

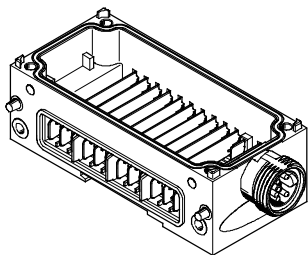

System linking

- Different voltages for supplying the modules
- Serial communication between the modules

System supply

- 7/8" 5-pin
- AIDA push-pull

In addition to system interlinking, power supply for the

- electronics plus sensors (16 A)
- valves plus actuators (16 A)

Additional power supply

In addition to system linking, power supply for the

- actuators (16 A per supply)

Power supply for the

- valves (16 A per supply)

Expandability

- Can be expanded as required by up to 10 interlinking blocks

Technical data → 707 ff.

Note

The 7/8" supply is subject to the following restriction due to the available accessories:

- 5-pin 8 A
- 4-pin 10 A

Note

Plastic interlinking blocks (tie rods) and metal interlinking blocks (individual linking) cannot be combined due to their different interlinking systems.

Pneumatic interface MPA-S

Technical data → 709

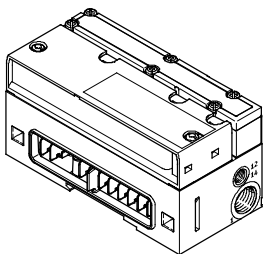

Valve terminal

- MPA1 (360 l/min)
- MPA2 (700 l/min)
- Up to 128 solenoid coils
- Up to 16 modules can be configured
- For CPX plastic design
- For CPX metal design
- Proportional pressure regulators
- Pressure sensors

Pneumatic interface MPA-L

Technical data → 709

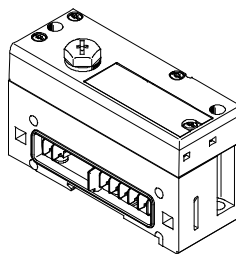

Valve terminal

- MPAL1 (360 l/min)
- MPAL14 (670 l/min)
- MPAL2 (870 l/min)
- Up to 32 solenoid coils
- For CPX plastic design

9

Pneumatic interface VTSA/VTSA-F

Technical data → 710

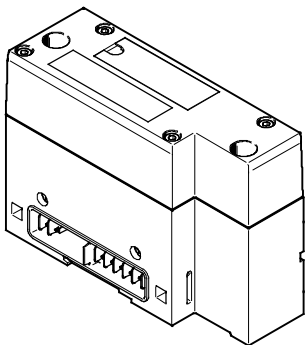

Valve terminal (valve flow rate by widths)

- 18 mm (700 l/min)
- 26 mm (1,350 l/min)
- 42 mm (1,300 l/min)
- 52 mm (2,900 l/min)
- 65 mm (4,000 l/min)
- Max. 32 valve positions/
max. 32 solenoid coils
- For CPX plastic design
- For CPX metal design

Earthing plate (for plastic end plate)

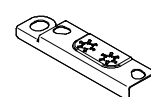

Earthing plate

- For safe and easy connection to the machine bed or H-rail, suitable for right-hand and left-hand end plate
- Assembly and earthing in a single processing step, which means:
 - 50% time saving
 - No additional material required

Plastic end plate

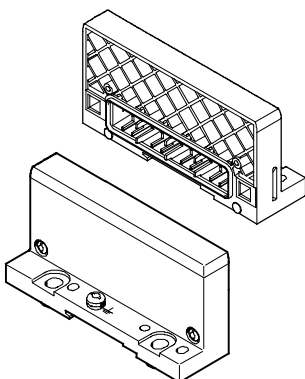

End plate

- Left-hand
- Right-hand (for use without valves)

Metal end plate

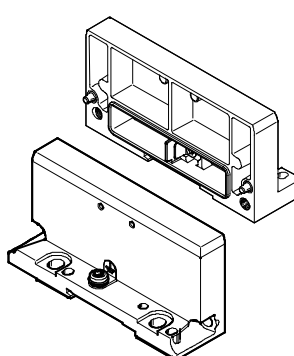

End plate

- Left-hand
- Right-hand (for use without valves)

Technical data

General basic data and guidelines

- Max. 11 modules in total:
- One bus node and/or one control block, freely positionable
- Up to 9 additional input/output modules, freely positionable
- An additional pneumatic interface, always positioned as the last module on the right-hand side
 - With VTSA, VTSA-F and MPA-L: fixed operating range, set using switch at the pneumatic interface
 - With MPA-S: 16 MPA-S modules can be configured
- Address capacity max. 512 inputs and 512 outputs, depending on the bus node or control block
- The maximum system configuration can be limited in individual cases by exceeding the address space
- One interlinking block with system supply, freely positionable
- Multiple interlinking blocks with additional power supply, always positioned to the right of the interlinking block with system supply
- The connection blocks can, with just a few exceptions, be freely combined with the electronics modules for inputs/outputs, either in metal or plastic (➔ table below)
- All electronics modules for inputs/outputs can be combined with any interlinking block
- Plastic interlinking blocks (tie rods) and metal interlinking blocks (individual linking) cannot be combined due to their different interlinking systems

Combinations of connection blocks and digital electronics modules for inputs/outputs

Connection blocks	Digital electronics modules								
	CPX-8DE	CPX-8NDE	CPX-16DE	CPX-M-16DE-D	CPX-4DA	CPX-8DA-H	CPX-8DE-8DA	CPX-FVDA-P	CPX-FVDA-P2
Plastic design with mounting screws for assembly on plastic interlinking blocks									
CPX-AB-8-M8-3POL	■	■	–	–	■	–	–	–	–
CPX-AB-8-M8X2-4POL	–	–	■	–	■	■	–	–	–
CPX-AB-4-M12x2-5POL	■	■	–	–	■	–	–	–	–
CPX-AB-4-M12x2-5POL-R	■	■	–	–	■	■	–	–	–
CPX-AB-8-KL-4POL	■	■	■	–	■	■	■	–	■
CPX-AB-1-SUB-BU-25POL	■	■	■	–	■	■	■	–	–
CPX-AB-4-HAR-4POL	■	■	–	–	■	–	–	–	–
Plastic design with mounting screws for assembly on metal plates									
CPX-AB-8-M8x2-4P-M3	–	–	■	–	■	■	–	–	–
CPX-AB-4-M12-8P-M3	–	–	–	–	–	–	■	–	–
CPX-AB-4-M12x2-5P-R-M3	■	■	–	–	■	■	–	–	–
Metal design with mounting screws for assembly on metal and plastic interlinking blocks									
CPX-M-AB-4-M12x2-5POL	■	■	–	–	■	■	–	■	■
CPX-M-AB-8-M12x2-5POL	–	–	–	■	–	–	–	–	–

Combinations of connection blocks and analogue electronics modules for inputs/outputs

Connection blocks	Analogue electronics modules					
	CPX-2AE-U-I	CPX-4AE-I	CPX-4AE-P	CPX-4AE-T	CPX-4AE-TC	CPX-2AA-U-I
Plastic design with mounting screws for assembly on plastic interlinking blocks						
CPX-AB-4-M12x2-5POL	■	■	–	■	■	■
CPX-AB-4-M12x2-5POL-R	■	■	–	■	■	■
CPX-AB-8-KL-4POL	■	■	–	■	■	■
CPX-AB-1-SUB-BU-25POL	■	■	–	–	–	■
CPX-AB-4-HAR-4POL	–	–	–	■	–	–
Plastic design with mounting screws for assembly on metal plates						
CPX-AB-4-M12x2-5P-R-M3	■	■	–	■	■	■
Metal design with mounting screws for assembly on metal and plastic interlinking blocks						
CPX-M-AB-4-M12x2-5POL	■	■	–	■	■	■

Technical data – Electrical terminal CPX

- [J] - Module width
50 mm

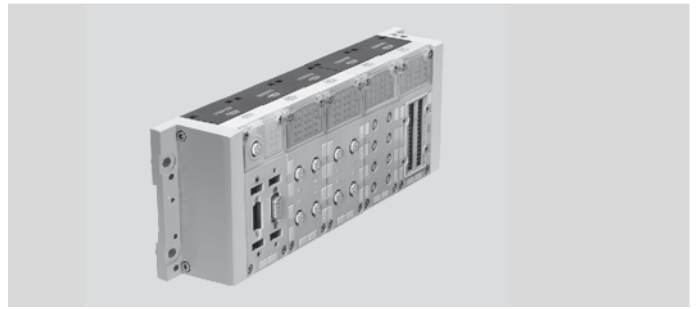

General technical data

Max. number of modules ¹⁾	Control block		1
	Bus node		1
	I/O modules/CP interface/axis interface		9
	Pneumatic interface		1
	MPA-S electronics		8
Max. address capacity	Inputs	[byte]	64
	Outputs	[byte]	64
Configuration support			Fieldbus-specific
LED displays	Bus node/control block		Up to 4 LEDs, bus-specific 4 LEDs, CPX-specific PS = Power system PL = Power load SF = System fault M = Modify parameter/forcing active
		I/O modules	Min. one centralised diagnostic LED Channel-oriented status and diagnostic LED, depending on module
	Pneumatic interface		One centralised diagnostic LED Valve status LED on valve
Diagnostics			Channel and module-oriented diagnostics for inputs/outputs and valves Detection of module undervoltage for the different potential values Storage of the last 40 errors with timestamp (acyclic access)
	Parameterisation, module-specific and entire system, for example		Diagnostic behaviour
			Condition monitoring
		Profile of inputs	
		Fail-safe response of outputs and valves	
Commissioning support			Forcing of inputs and outputs
Protection class to EN 60529			IP65/IP67
Tests	Vibration test to DIN IEC 68		With wall mounting: severity level 2 With H-rail mounting: severity level 1
		Shock test to DIN IEC 68	With wall mounting: severity level 2 With H-rail mounting: severity level 1
	Resistance to interference		EN 61000-6-2 (industry)
	Emitted interference		EN 61000-6-4 (industry)
Grid dimension		[mm]	50

1) A maximum of 11 modules in total can be combined
(e.g. 1 control block + 9 I/O modules + 1 pneumatic interface, or 1 control block + 1 bus node + 8 I/O modules + 1 pneumatic interface)

Technical data – Electrical terminal CPX

Download CAD data → www.festo.com

Electrical data		
Power supply	Interlinking block with system supply	
	Electronics plus sensors [V]	24 DC, max. 16 A (8 A/10 A with 7/8" supply, 5-pin/4-pin)
	Actuators plus valves [V]	24 DC, max. 16 A (8 A/10 A with 7/8" supply, 5-pin/4-pin)
	Additional power supply	
Actuators	[V]	24 DC, max. 16 A per supply (8 A/10 A with 7/8" supply, 5-pin/4-pin)
	Valves [V]	24 DC, max. 16 A per supply (/10 A with 7/8" supply, 4-pin)
Current consumption		Depending on system configuration
Power failure bridging (bus electronics only)	[ms]	10
Power supply connection		M18 4-pin
		7/8" 5-pin
		7/8" 4-pin
		AIDA push-pull, 5-pin
Fuse concept		Per module with electronic fuses
Isolation test for galvanically isolated circuits to IEC 1131 Part 2	[V]	500 DC
Galvanic isolation of electrical voltages	[V]	80 DC
Protection against direct and indirect contact		PELV

Operating conditions

Temperature range, electronics	Operation [°C]	-5 ... +50
	Storage/transport [°C]	-20 ... +70
Temperature range, electronics plus pneumatic components	Operation [°C]	-5 ... +50
	Storage/transport [°C]	-20 ... +40

Materials

Housing	Die-cast aluminium, PA reinforced, PC
---------	---------------------------------------

Technical data – Operator unit CPX-MMI-1

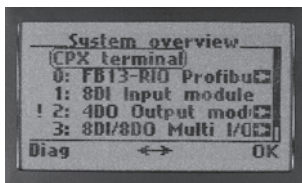

Technical data

Download CAD data → www.festo.com

Display component		LCD graphic display with background illumination (128 x 64 pixels)
Control elements		7 keys: 4 arrow keys and 3 function keys
Interface		M12 5-pin, pin
Operating voltage	[V]	24 DC, supplied by the connected device
Current consumption	[mA]	50 ... 60
Length/width/height	[mm]	137/81/28

Terminal CPX

Technical data – Control block CPX-FEC-1-IE

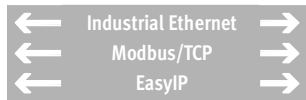

IT services:

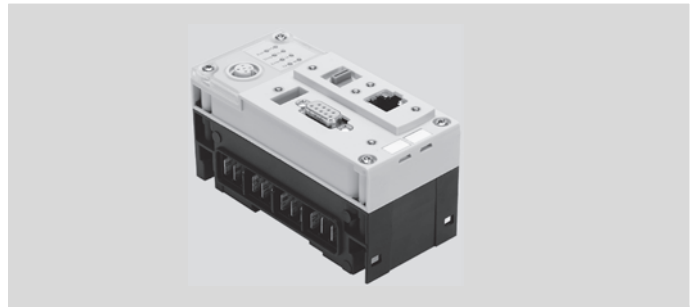

Technical data			Download CAD data → www.festo.com
Ethernet interface			RJ45 (8-pin, socket)
Data interface			RS232 (Sub-D, 9-pin, socket)
MMI interface			M12, 5-pin, socket
Baud rates	Ethernet interface	[Mbps]	10/100 (to IEEE802.3, 10BaseT)
	Data interface	[kbps]	9.6 ... 115.2
	MMI interface	[kbps]	56.6
Protocol			TCP/IP, Easy IP, Modbus TCP, HTTP
Flags			M0.0 ... M9999, addressable as bits or words
	Number of time flags		T0 ... T255
	Time range	[s]	0.01 to 655.35
	Number of counting flags		Z0 ... Z255
	Counting range		0 to 65535
Register			R0 ... R255, addressable as words
IP address setting			BOOTP/DHCP via FST or via MMI/FMT
Max. address capacity	Inputs/outputs	[byte]	64/64
Program memory	User program	[kB]	250
	Web applications	[kB]	550
Programming language			IL, LD
Parameterisation			Start-up parameterisation via FST
			Parameterisation during the operating time via functional module
Control elements			DIL switch for setting the operating mode
			Rotary switch for program selection/program start
Additional functions			Storage of the last 40 errors with timestamp (access via PCP)
			8-bit system status in image table for inputs
			2-byte inputs and 2-byte outputs, system diagnostics in image table
Current consumption		[mA]	Max. 200
Length/width/height (incl. interlinking block)		[mm]	107/50/55

Overview of the operating modes	Stand-alone	Remote Controller	
		Ethernet	Fieldbus
CPX-FEC-1-IE function	Control	Control and communication	
CPX module controlled by	CPX-FEC-1-IE	CPX-FEC-1-IE	
Pre-processing of data in the FEC	Yes	Yes	
Communication with higher-order controller	No	Via Ethernet • EasyIP • Modbus TCP	Via fieldbus
Web server	Possible	Possible	
Configuration	FST 4.1 or higher	FST 4.1 or higher	
Parameterisation	Via FST/CPX-MMI/CPX-FMT	Via FST/CPX-MMI/CPX-FMT	
Order code	T03	T03	
Addressing	Changeable	Changeable	
Memory	<ul style="list-style-type: none"> 250 kB for user program 550 kB for web applications 	<ul style="list-style-type: none"> 250 kB for user program 550 kB for web applications 	
CPX-MMI/-FMT	Can be connected to CPX-FEC-1-IE	Can be connected to CPX-FEC-1-IE	

Technical data – Control block CPX-CEC

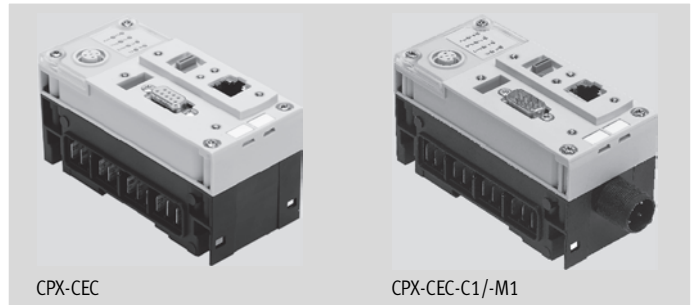
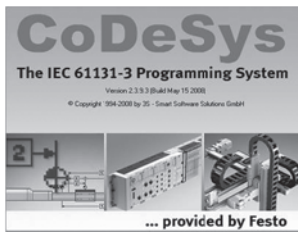

CPX-CEC

CPX-CEC-C1/-M1

Technical data		Download CAD data → www.festo.com	
Type		CPX-CEC-C1	CPX-CEC-M1
Ethernet interface		RJ45 (socket, 8-pin)	
Transmission speed	[Mbps]	10/100	
Supported protocols		TCP/IP, Easy IP, Modbus TCP (server)	
Fieldbus interface		CAN bus (plug, Sub-D, 9-pin)	
Transmission rate	[kbps]	125; 250; 500; 800; 1,000	125; 250; 500; 1,000
		Can be set using software	Can be set using software
Data interface		–	
Flags		30 kB remanent memory 8 MB global data memory CoDeSys variable concept	
IP address setting		DHCP via CoDeSys or via MMI	
Program memory		4 MB user program	
Programming software		CoDeSys provided by Festo	
Programming language		SFC, IL, FCH, LD and ST to IEC 61131-3 Also CFC	
Parameterisation		CoDeSys	
Configuration support		CoDeSys	
Control elements		DIL switch for CAN termination Rotary switch for RUN/STOP	
Function blocks		CPX diagnostic status, Copy CPX diagnostic trace, Read CPX module diagnostics And others	
Additional functions		Diagnostic functions	
		Motion functions for electric drives	SoftMotion functions for electric drives
Total number of axes		31	31 (recommended: max. 8)
Intrinsic current consumption at nominal operating voltage	[mA]	Typically 85	
Length/width/height (incl. interlinking block)	[mm]	50/107/55	

Terminal CPX

Technical data – Bus node CPX-FB6



Technical data		Download CAD data → www.festo.com
Fieldbus interface		Sub-D, 9-pin, socket and pin
Baud rates	[Mbps]	0.5 and 2
Max. number of process data bits	Inputs/outputs [bit]	96/96
Parameterisation		Start-up parameterisation via user functions (CMD) Via PCP communication
Additional functions		Storage of the last 40 errors with timestamp (access via PCP) 8-bit system status in image table for inputs 2-byte inputs and 2-byte outputs, system diagnostics in image table
Current consumption	[mA]	Max. 200
Length/width/height (incl. interlinking block)	[mm]	107/50/55

Technical data – Bus node CPX-FB11



Technical data		Download CAD data → www.festo.com
Fieldbus interface	Either	Micro style bus connection: 2x M12 with protection to IP65/IP67 Open style bus connection: 5-pin terminal strip, IP20
Baud rates	[kbps]	125, 250, 500
Addressing range		0 ... 63, set using DIL switch
Communication types		Polled I/O, change of state/cyclic, strobed I/O and explicit messaging
Max. address capacity	Inputs/outputs [byte]	64/64
Parameterisation		Module and system parameterisation via configuration interface in plain text (EDS) Online in run or program mode
Additional functions		Storage of the last 40 errors with timestamp (access via EDS) 8-bit system status in image table for inputs 2-byte inputs and 2-byte outputs, system diagnostics in image table
Current consumption	[mA]	Max. 200
Length/width/height (incl. interlinking block)	[mm]	107/50/50

Technical data – Bus node CPX-FB13

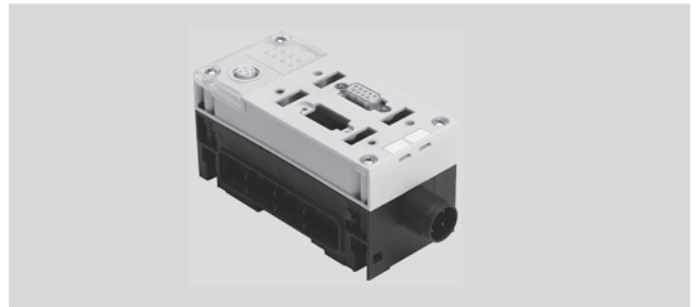

Technical data		Download CAD data → www.festo.com
Fieldbus interface		Sub-D socket, 9-pin (EN 50170), galvanically isolated 5 V
Baud rates	[Mbps]	0.0096 ... 12
Addressing range		1 ... 125, set using DIL switch
Communication types	DPV0	Cyclic communication
	DPV1	Acyclic communication
Max. address capacity	Inputs/outputs	[byte] 64/64
Parameterisation		Start-up via configuration interface in plain text (GSD)
		Acyclic parameterisation via DPV1
Additional functions		Storage of the last 40 errors with timestamp (access via DPV1)
		8-bit system status in image table for inputs
		2-byte inputs and 2-byte outputs, system diagnostics in image table
Current consumption	[mA]	Max. 200
Length/width/height (incl. interlinking block)	[mm]	107/50/50

Technical data – Bus node CPX-FB14

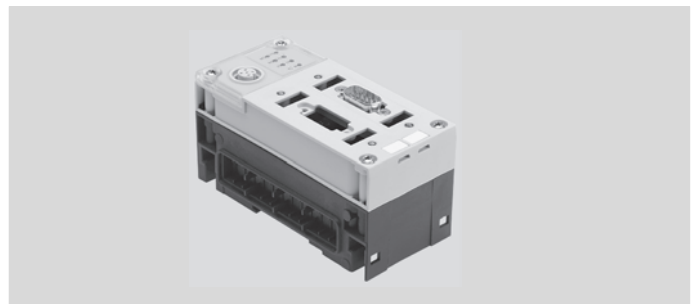

Technical data		Download CAD data → www.festo.com
Fieldbus interface		Sub-D pin, 9-pin (to DS 102), galvanically isolated via optocoupler, 24 V supply for CAN interface via bus
Baud rates	[kbps]	125; 250; 500 and 1,000 can be set via DIL switch
Communication profile		DS 301, V4.01
Max. address capacity	Inputs/outputs	[byte] 16 digital, 16 analogue channels/16 digital, 16 analogue channels
Parameterisation		Via SDO
Additional functions		Storage of the last 40 errors with timestamp (access via SDO)
		8-bit system status via transmit PDO 4 (default)
		2-byte inputs and 2-byte outputs, system diagnostics via PDO 4
		Minimum boot-up
		Variable PDO mapping
		Emergency message
		Node guarding
Current consumption	[mA]	Max. 200
Length/width/height (incl. interlinking block)	[mm]	107/50/50

Technical data – Bus node CPX-FB23-24

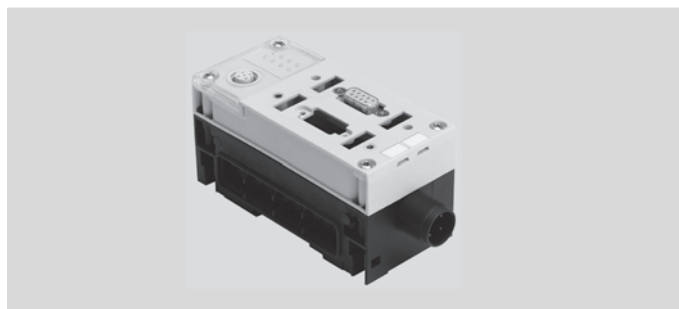

Technical data				Download CAD data → www.festo.com
Fieldbus interface, either		Sub-D socket, 9-pin		
		Screw terminal bus connection, IP20		
Baud rates		[kbps]	156 ... 10,000	
Number of stations per slave		1, 2, 3 or 4 stations, set using DIL switch		
Communication types		Cyclic communication		
Max. address capacity, inputs	FB23	RWr	[Byte]	32
		Rx	[Byte]	14
	FB24	RWr	[Byte]	64
		Rx	[Byte]	64
Max. address capacity, outputs	FB23	RWw	[Byte]	32
		Ry	[Byte]	14
	FB24	RWw	[Byte]	64
		Ry	[Byte]	64
Parameterisation		Hold/clear via DIL switch		
Additional functions		Storage of the last 40 errors with timestamp (access via system diagnostics)		
Current consumption		[mA]	Max. 200	
Length/width/height (incl. interlinking block)		Length/ width/ height (incl. interlinking block)	[mm]	107/50/50

9

Technical data – Bus node CPX-FB32

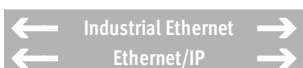

IT services:



Technical data				Download CAD data → www.festo.com
Fieldbus interface		Plug connector M12, D-coded, 4-pin		
Baud rates		[Mbps]	10/100, full/half duplex	
IP addressing		Via DHCP, DIL switch or network software		
Max. address capacity	Inputs/outputs	[byte]	64/64	
Parameterisation		Start-up parameterisation		
		Acyclic parameterisation via explicit messaging		
Additional functions		Storage of the last 40 errors with timestamp (access via system diagnostics)		
		8-bit system status in image table for inputs		
		2-byte I/O, system diagnostics via image table		
Current consumption		[mA]	Typically 65	
Length/width/height (incl. interlinking block)		[mm]	107 x 50 x 50	

Technical data – Bus node CPX-FB33

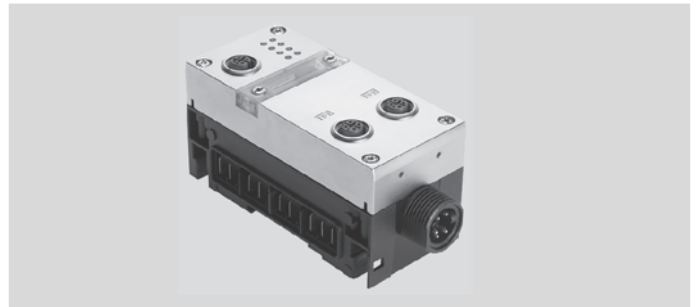

Technical data		Download CAD data → www.festo.com
Fieldbus interface		2x M12 socket, D-coded, 4-pin
Baud rates	[Mbps]	100
Max. address capacity	Inputs/outputs [byte]	64/64
Parameterisation		System parameters
		Diagnostic behaviour
		Signal setup
		Fail-safe response
		Forcing of channels
Additional functions		Start-up parameterisation in plain text via fieldbus
		Fast start-up (FSU)
		Channel-oriented diagnostics via fieldbus
		Acyclic data access via fieldbus
		System status can be displayed using process data
		Additional diagnostic interface for operator units
		Acyclic data access via Ethernet
Current consumption	[mA]	Typically 120
Length/width/height (incl. interlinking block)	[mm]	107/50/50

Technical data – Bus node CPX-M-FB34



Technical data		Download CAD data → www.festo.com
Fieldbus interface		2x RJ45 push-pull socket, AIDA
Baud rates	[Mbps]	100
Max. address capacity	Inputs/outputs [byte]	64/64
Parameterisation		System parameters
		Diagnostic behaviour
		Signal setup
		Fail-safe response
		Forcing of channels
Additional functions		Start-up parameterisation in plain text via fieldbus
		Fast start-up (FSU)
		Channel-oriented diagnostics via fieldbus
		Acyclic data access via fieldbus
		System status can be displayed using process data
		Additional diagnostic interface for operator units
		Acyclic data access via Ethernet
Current consumption	[mA]	Typically 120
Length/width/height (incl. interlinking block)	[mm]	107/50/80

Terminal CPX

Technical data – Bus node CPX-M-FB35



Technical data		Download CAD data → www.festo.com
Fieldbus interface		2x SCRJ push-pull socket, AIDA
Baud rates	[Mbps]	100
Max. address capacity	Inputs/outputs [byte]	64/64
Parameterisation		System parameters
		Diagnostic behaviour
		Signal setup
		Fail-safe response
		Forcing of channels
Additional functions		Start-up parameterisation in plain text via fieldbus
		Fast start-up (FSU)
		Channel-oriented diagnostics via fieldbus
		Acyclic data access via fieldbus
		System status can be displayed using process data
		Additional diagnostic interface for operator units
Current consumption	[mA]	Typically 150
Length/width/height (incl. interlinking block)	[mm]	107/50/80

9

Technical data – Bus node CPX-FB38



Technical data		Download CAD data → www.festo.com
Fieldbus interface		Two plug connectors M12, D-coded, 4-pin
Baud rates	[Mbps]	100
Max. address capacity	Inputs/outputs [byte]	64/64
Parameterisation		System parameters
		Diagnostic behaviour
		Signal setup
		Fail-safe response
		Forcing of channels
Additional functions		System status can be displayed using process data
		Additional diagnostic interface for operator units
Current consumption	[mA]	Typically 100
Length/width/height (incl. interlinking block)	[mm]	107/50/50

Technical data – Interface CPX-CP-4-FB

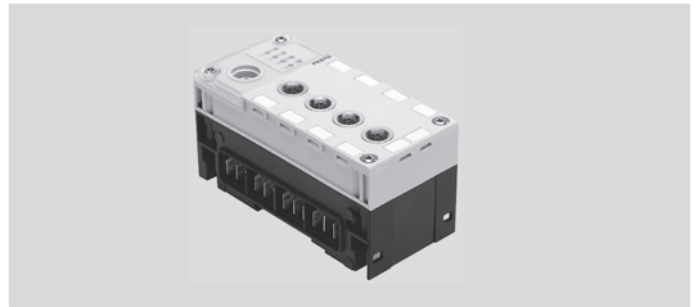
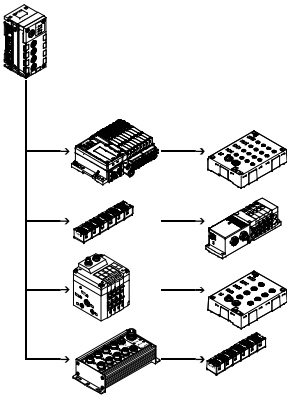

Technical data

[Download CAD data → www.festo.com](http://www.festo.com)

CP connection	Socket M9, 5-pin	
Max. number of	CP strings	4
	CP modules per string	4
	Outputs per string	32
	Inputs per string	32
Baud rate	[kbps]	1,000
Sensor supply voltage	[V DC]	24 ±25% coming from bus node
Actuator load voltage	[V DC]	24 ±10% coming from bus node
Current consumption	Without CP modules	[A] Max. 0.2
	Per CP string	[A] Max. 1.6
Length/width/height (incl. interlinking block)	[mm]	107/50/45

Technical data – Interface CPX-CTEL-4-M12-5POL

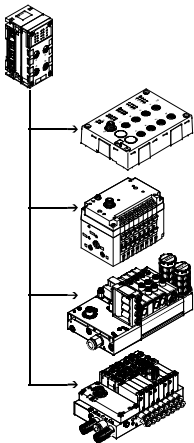

Technical data

[Download CAD data → www.festo.com](http://www.festo.com)

I-Port connection	4x socket M12, 5-pin, A-coded	
Max. address capacity	Inputs/outputs	[bit] 256/256
Number of I-Port interfaces	4	
Max. cable length	[m]	20
Internal cycle time	[ms]	1 per 8 bits of user data
Additional functions	Tool change mode	
Max. power supply per channel	[A]	4 x 1.6
Max. residual current of outputs per channel	[A]	4 x 1.6
Intrinsic current consumption at nominal operating voltage	[mA]	Typically 65
Length/width/height (incl. interlinking block)	[mm]	107/50/55

Terminal CPX

Technical data – Control block CPX-CM-HPP

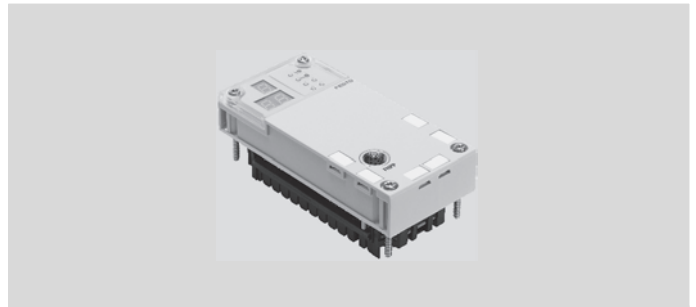
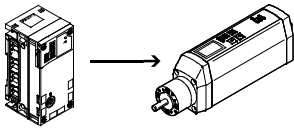

Technical data		Download CAD data → www.festo.com
Fieldbus interface		1x socket M9, 5-pin
Control interface		CAN bus
Baud rate	[Mbps]	1
Protocol		FHPP
Max. address capacity	Inputs/outputs	[byte] 32/32
Parameterisation		Forcing of channels System parameters
Total number of axes		4
Intrinsic current consumption at nominal operating voltage	[mA]	Typically 80
Length/width/height (incl. interlinking block)	[mm]	107/50/55

Technical data – Digital input module with 8 inputs, CPX-8DE, CPX-8NDE

Possible connection blocks:

- CPX-AB-8-M8-3POL
- CPX-AB-4-M12X2-5POL
- CPX-AB-4-M12X2-5POL-R
- CPX-AB-8-KL-4POL
- CPX-AB-1-SUB-BU-25POL
- CPX-AB-4-HAR-4POL
- CPX-M-AB-4-M12X2-5POL
- CPX-M-AB-8-M12X2-5POL

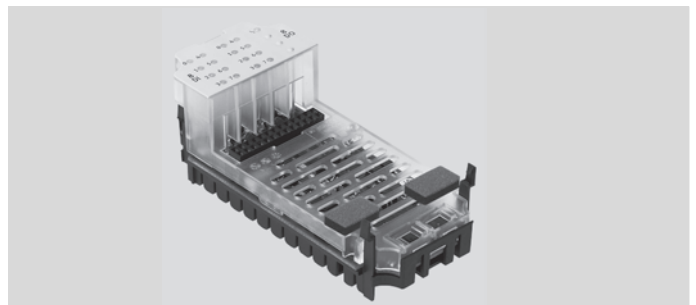

Technical data		Download CAD data → www.festo.com	
Type		CPX-8DE	CPX-8NDE
Number of inputs		8	
Max. residual current of inputs per module	[A]	1	0.7
Internal electronic fuse		Per module	Per module
Intrinsic current consumption at operating voltage	[mA]	Typically 15	Typically 15
Sensor supply voltage	[V DC]	24 ±25%	24 ±25%
Electrical isolation	Channel – channel	No	No
	Channel – internal bus	No	No
Switching level	Signal 0 [V DC]	≤ 5	≥ 11
	Signal 1 [V DC]	≥ 11	≤ 5
Input characteristic		IEC 1131-T2	
Switching logic		Positive logic (PNP)	Negative logic (NPN)
Parameterisation		Module monitoring	
		Behaviour after short circuit	
		Input debounce time	
		Signal extension time	

Technical data – Digital input module with 16 inputs, CPX-16DE, CPX-M-16DE-D

Possible connection blocks

CPX-16DE:

- CPX-AB-8-M8X2-4POL
- CPX-AB-8-M8X2-4P-M3
- CPX-AB-8-KL-4POL
- CPX-AB-1-SUB-BU-25POL

Possible connection blocks

CPX-M-16DE-D:

- CPX-M-AB-8-M12X2-5POL

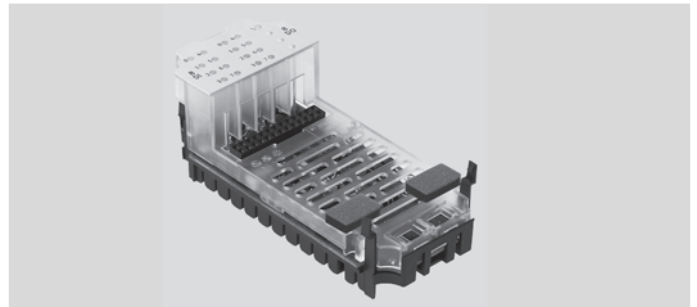

Technical data		Download CAD data → www.festo.com	
Type		CPX-16DE	CPX-M-16DE-D
Number of inputs		16	
Max. residual current of inputs per module	[A]	1.8	1.8
Internal electronic fuse		Per module	Per channel pair
Intrinsic current consumption at operating voltage	[mA]	Typically 15	Typically 34
Sensor supply voltage	[V DC]	24 ±25%	24 ±25%
Electrical isolation	Channel – channel	No	No
	Channel – internal bus	No	No
Switching level	Signal 0 [V DC]	≤ 5	≤ 5
	Signal 1 [V DC]	≥ 11	≥ 11
Input characteristic		IEC 1131-2	
Switching logic		Positive logic (PNP)	Positive logic (PNP)
Parameterisation		Module monitoring	
		Behaviour after short circuit	
		Input debounce time	
		Signal extension time	

Technical data – Digital output module with 4 outputs, CPX-4DA

Possible connection blocks:

- CPX-AB-8-M8-3POL
- CPX-AB-8-M8X2-4POL
- CPX-AB-8-M8X2-4P-M3
- CPX-AB-4-M12X2-5POL
- CPX-AB-4-M12X2-5POL-R
- CPX-AB-8-KL-4POL
- CPX-AB-1-SUB-BU-25POL
- CPX-AB-4-HAR-4POL
- CPX-AB-4-M12X2-5P-R-M3
- CPX-M-AB-4-M12X2-5POL

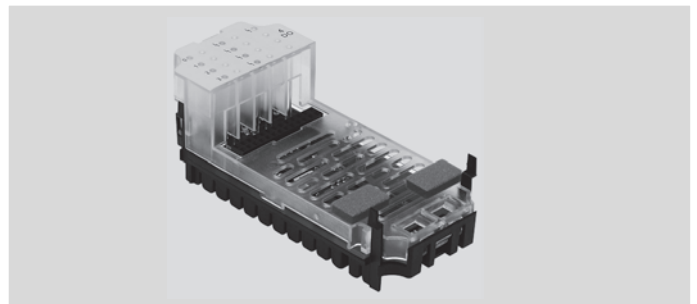

Technical data		Download CAD data → www.festo.com	
Type		CPX-4DA	
Number of outputs		4	
Max. power supply	Per module [A]	4	
	Per channel [A]	1 (24 W lamp load, 4 channels can be connected in parallel)	
Fuse protection (short circuit)		Internal electronic fuse per channel	
Module current consumption (voltage supply for electronics)	[mA]	Typically 16	
Supply voltage	[V DC]	24 ±25%	
Electrical isolation	Channel – channel	No	
	Channel – internal bus	Yes, with intermediate supply	
Output characteristic		To IEC 1131-2	
Switching logic		Positive logic (PNP)	
Parameterisation		Module monitoring	
		Behaviour after short circuit	
		Fail-safe channel x	
		Forcing channel x	
		Idle mode channel x	

Technical data – Digital output module with 8 high-current outputs, CPX-8DA-H

Possible connection blocks:

- CPX-AB-8-M8X2-4POL
- CPX-AB-8-M8X2-4P-M3
- CPX-AB-4-M12X2-5POL-R
- CPX-AB-8-KL-4POL
- CPX-AB-1-SUB-BU-25POL
- CPX-AB-4-M12X2-5P-R-M3
- CPX-M-AB-4-M12X2-5POL

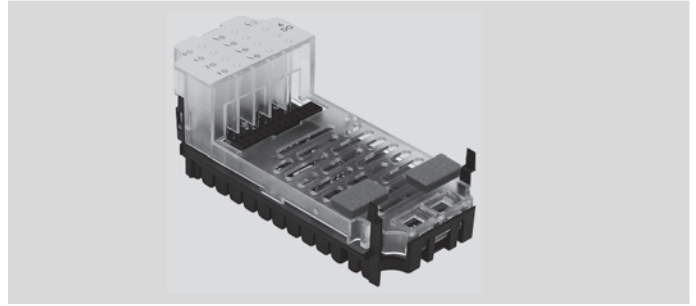

Download CAD data → www.festo.com

Technical data			CPX-8DA-H
Type			CPX-8DA-H
Number of outputs			8
Max. power supply	Per module	[A]	8.4
	Per channel	[A]	2.1 (50 W lamp load) per channel pair
Fuse protection (short circuit)			Internal electronic fuse per channel
Module current consumption (voltage supply for electronics)		[mA]	Typically 34
Supply voltage			24 ±25%
Electrical isolation	Channel – channel		No
	Channel – internal bus		Yes, with intermediate supply
Output characteristic			To IEC 1131-2
Switching logic			Positive logic (PNP)
Parameterisation			Module monitoring
			Behaviour after short circuit
			Fail-safe channel x
			Forcing channel x
		Idle mode channel x	

Technical data – Digital input/output module with 8 inputs and 8 outputs, CPX-8DE-8DA

Possible connection blocks:

- CPX-AB-4-M12-8POL
- CPX-AB-4-M12-8P-M3
- CPX-AB-8-KL-4POL
- CPX-AB-1-SUB-BU-25POL

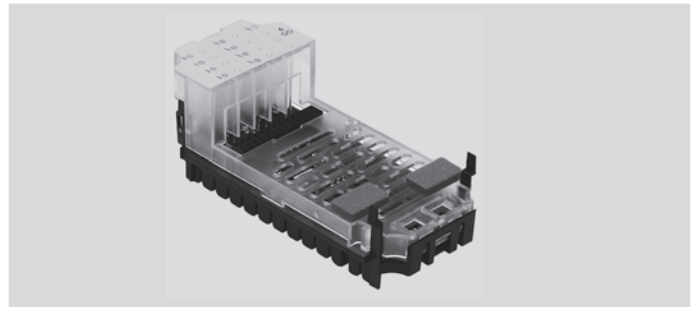

Technical data		Download CAD data → www.festo.com	
Type	CPX-8DE-8DA		
Number	Inputs/outputs		8/8
Max. power supply per module	Sensor supply	[A]	0.7
	Outputs	[A]	4
Max. power supply per channel		[A]	0.5 (12 W lamp load, channels A0 ... A03 can be connected in parallel to A4 ... A7)
Fuse protection	Sensor supply		Internal electronic fuse for sensor supply
	Outputs		Internal electronic fuse per channel
Current consumption of internal electronics	Inputs/outputs	[mA]	Typically 22/typically 34
	Sensors/outputs	[V DC]	24 ±25%/24 ±25%
Electrical isolation, inputs	Channel – channel		No
	Channel – internal bus		No
Electrical isolation, outputs	Channel – channel		No
	Channel – internal bus		Yes, with intermediate supply
Characteristic	Inputs/outputs		IEC 1131-2/IEC 1131-2
Switching logic			Positive logic (PNP)
Parameterisation	Inputs		Module monitoring
			Behaviour after short circuit, sensor supply
			Input debounce time
		Signal stretching time, inputs	
	Outputs		Behaviour after short circuit
			Fail-safe channel x
			Forcing channel x
			Idle mode channel x

Technical data – Analogue input module with 2 inputs, CPX-2AE-U-I

Possible connection blocks:

- CPX-AB-4-M12X2-5POL
- CPX-AB-4-M12X2-5POL-R
- CPX-AB-8-KL-4POL
- CPX-AB-1-SUB-BU-25POL
- CPX-AB-4-M12X2-5P-R-M3
- CPX-M-AB-4-M12X2-5POL

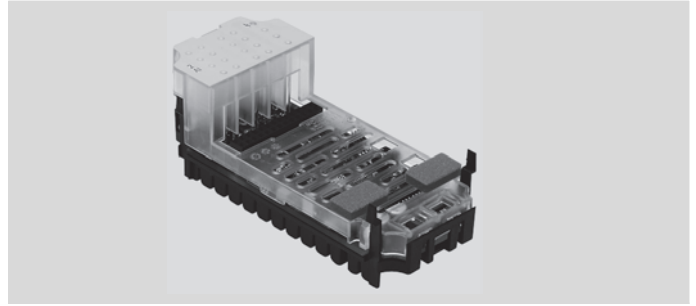

Technical data		Download CAD data → www.festo.com	
Type	CPX-2AE-U-I		
		Voltage input	Current input
Number of inputs		2	2
Max. power supply per module	[A]	0.7	0.7
Fuse protection	Internal electronic fuse for sensor supply		
Current consumption from 24 V sensor supply (quiescent current)	[mA]	Typically 50	Typically 50
Current consumption from 24 V sensor supply (at full load)	[A]	Max. 0.7	Max. 0.7
Sensor supply voltage	[V DC]	24 ±25%	24 ±25%
Signal range (parameterisable for each channel by means of DIL switch or software)		0 ... 10 V DC	0 ... 20 mA 4 ... 20 mA
Resolution		12 bits	
Absolute accuracy	[%]	±0.5	±0.6
Input resistance		100 kΩ	≤ 100 Ω
Max. permissible input voltage	[V DC]	30	–
Max. permissible input current	[mA]	–	40
Data format	Prefix + 15 bits, linear scaling Prefix + 15 bits left-aligned, S7 compatible Prefix + 12 bits left-aligned + diagnostics, S5 compatible		
Cable length	Max. 30 m (screened)		
Electrical isolation	Channel – channel	No	
	Channel – internal bus	Yes, with external sensor supply	
	Channel – sensor supply	Yes, with external sensor supply	
Parameterisation	Short circuit monitoring, sensor supply		
	Behaviour after short circuit, sensor supply		
	Data format		
	Lower limit value/full-scale value		
	Upper limit value/full-scale value		
	Monitoring of value falling below nominal range/full-scale value		
	Monitoring of value exceeding nominal range/full-scale value		
	Monitoring of wire break (measuring range 4 ... 20 mA)		
	Signal range		
	Measured value smoothing		

Technical data – Analogue input module with 2 or 4 inputs, CPX-4AE-I

Possible connection blocks:

- CPX-AB-4-M12X2-5POL
- CPX-AB-4-M12X2-5POL-R
- CPX-AB-8-KL-4POL
- CPX-AB-1-SUB-BU-25POL
- CPX-AB-4-M12X2-5P-R-M3
- CPX-M-AB-4-M12X2-5POL

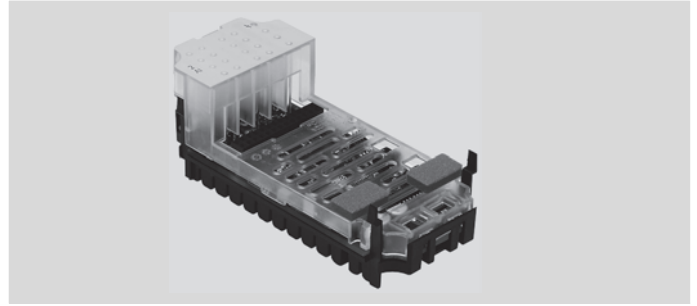

Technical data		Download CAD data → www.festo.com
Type		CPX-4AE-I
		Current input
Number of inputs		2 or 4
Max. power supply per module	[A]	0.7
Fuse protection		Internal electronic fuse for sensor supply
Current consumption from 24 V sensor supply (quiescent current)	[mA]	Typically 50
Current consumption from 24 V sensor supply (at full load)	[A]	Max. 0.7
Sensor supply voltage	[V DC]	24 ±25%
Signal range (parameterisable for each channel by means of DIL switch or software)		0 ... 20 mA 4 ... 20 mA
Resolution		12 bits
Absolute accuracy	[%]	±0.6
Input resistance		≤ 100 Ω
Max. permissible input voltage	[V DC]	–
Max. permissible input current	[mA]	40
Data format		Prefix + 15 bits, linear scaling Prefix + 15 bits left-aligned, S7 compatible Prefix + 12 bits left-aligned + diagnostics, S5 compatible
Cable length		Max. 30 m (screened)
Electrical isolation	Channel – channel	No
	Channel – internal bus	Yes, with external sensor supply
	Channel – sensor supply	Yes, with external sensor supply
Parameterisation		Short circuit monitoring, sensor supply
		Behaviour after short circuit, sensor supply
		Data format
		Lower limit value/full-scale value
		Upper limit value/full-scale value
		Monitoring of value falling below nominal range/full-scale value
		Monitoring of value exceeding nominal range/full-scale value
		Monitoring of wire break (measuring range 4 ... 20 mA)
		Signal range
		Measured value smoothing

Technical data – Analogue input module with 2 or 4 inputs for temperature sensors, CPX-4AE-T

Possible connection blocks:

- CPX-AB-4-M12X2-5POL
- CPX-AB-4-M12X2-5POL-R
- CPX-AB-8-KL-4POL
- CPX-AB-4-HAR-4POL
- CPX-AB-4-M12X2-5P-R-M3
- CPX-M-AB-4-M12X2-5POL

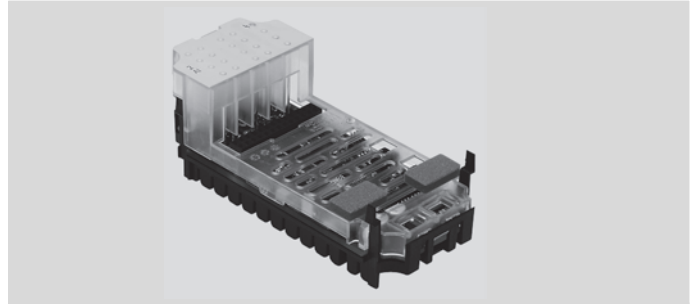

Download CAD data → www.festo.com

Technical data			CPX-4AE-T
Type			CPX-4AE-T
Number of inputs			2 or 4
Max. power supply per module	[A]		0.7
Fuse protection			Internal electronic fuse for sensor supply
Current consumption from 24 V sensor supply (quiescent current)	[mA]		Typically 50
Sensor supply voltage	[V DC]		24 ±25%
Sensor type (parameterisable for each channel by means of DIL switch)			PT100, PT200, PT500, PT1000 Ni100, Ni120, Ni500, Ni1000
Temperature range	Pt standard	[°C]	-200 ... +850
	Pt climatic	[°C]	-120 ... +130
	Ni	[°C]	-60 ... +180
Sensor connection technology			2-wire, 3-wire and 4-wire technology
Resolution			15 bits + prefix
Operating error limit relative to input range	[%]		±0.06
Basic error limit (25°C)	Standard	[K]	±0.6
	Pt climatic	[K]	±0.2
Temperature errors relative to input range	[%]		±0.001
Linearity errors (no software scaling)	[%]		±0.02
Repetition accuracy (at 25 °C)	[%]		±0.05
Max. line resistance per conductor	[Ω]		10
Max. permissible input voltage	[V DC]		±30
Data format			15 bits + prefix, complement of two, binary notation in tenths of a degree
Cable length	[m]		Max. 200 (screened)
Electrical isolation	Channel – channel		No
	Channel – internal bus		Yes
Parameterisation			Unit of measurement and interference frequency suppression
			Diagnostic message in the event of a wire break or short circuit
			Limit monitoring per channel
			Sensor connection technology
			Sensor type/temperature coefficient, temperature range
			Limit value per channel
			Measured value smoothing

Technical data – Analogue input module with 4 inputs for thermocoupler, CPX-4AE-TC

Possible connection blocks:

- CPX-AB-4-M12X2-5POL
- CPX-AB-4-M12X2-5POL-R
- CPX-AB-8-KL-4POL
- CPX-AB-4-M12X2-5P-R-M3
- CPX-M-AB-4-M12X2-5POL

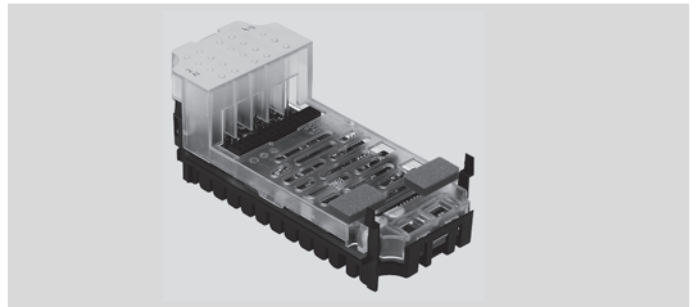

Technical data		Download CAD data → www.festo.com
Type		CPX-4AE-TC
Number of inputs		4
Fuse protection		Internal electronic fuse per channel
Sensor supply voltage	[V DC]	24 ±25%
Sensor type (parameterisable for each channel by means of software)		<ul style="list-style-type: none"> • Type B +400 ... +1,820 °C, 8 µV/°C • Type E -270 ... +900 °C, 60 µV/°C • Type J -200 ... +1,200 °C, 51 µV/°C • Type K -200 ... +1,370 °C, 40 µV/°C • Type N -200 ... +1,300 °C, 38 µV/°C • Type R 0 ... +1,760 °C, 12 µV/°C • Type S 0 ... +1,760 °C, 11 µV/°C • Type T -200 ... +400 °C, 40 µV/°C
Sensor connection technology		2-wire technology
Operating error limit relative to ambient temperature	[%]	Max. ±0.6
Basic error limit (at 25 °C)	[%]	Max. ±0.4
Repetition accuracy (at 25 °C)	[%]	±0.05
Max. line resistance per conductor	[Ω]	10
Max. residual current per module	[mA]	30
Max. permissible input voltage	[V]	±30
Internal cycle time (module)	[ms]	250
Data format		15 bits + prefix, complement of two, binary notation in tenths of a degree
Cable length	[m]	Max. 50 (screened)
Electrical isolation	Channel – channel	No
	Channel – internal bus	Yes
Diagnostics		Parameterisation error
		Wire break per channel
		Limit value violation per channel
Parameterisation		Wire break monitoring per channel
		Unit of measurement
		Cold-junction compensation
		Sensor type per channel
		Limit value monitoring per channel
		Measured value smoothing

Technical data – Analogue input module with pressure sensors, CPX-4AE-P

Tubing connections:

- 4x QS4



Technical data			Download CAD data → www.festo.com	
Type			CPX-4AE-P-B2	CPX-4AE-P-D10
Number of analogue inputs			4	
Nominal operating voltage	[V DC]	24 ±25%		
Intrinsic current consumption	[mA]	Typically 50		
Measured variable	4 x relative or 2 x differential pressure measurement			
Displayable units	kPa			
	mbar			
	psi			
Pressure measuring range	Starting value	[bar]	-1	0
	Final value	[bar]	1	10
Data format	15 bits + prefix			
	Binary notation in mbar, kPa, psi			
LED displays	Group diagnostics			
Diagnostics	Limit value violation per channel			
	Parameterisation error			
	Sensor limit per channel			
Parameterisation	Diagnostic delay per channel			
	Hysteresis per module			
	Unit of measurement			
	Measured value smoothing per channel			
	Limit value monitoring per channel			
	Sensor limit per channel			
Operating medium	Compressed air to ISO 8573-1:2010 [7:4:4]			
Note on operating/pilot medium	Lubricated operation possible (in which case lubricated operation will always be required)			
Temperature of medium	[°C]	0 ... 50		
Length/width/height (incl. interlinking block)	[mm]	107/50/55		

Note

Extreme pneumatic conditions, e.g. high cycle rate with high pressure amplitudes, can damage the sensors.

Technical data – Analogue output module with 2 inputs, CPX-2AA-U-I

Possible connection blocks:

- CPX-AB-4-M12X2-5POL
- CPX-AB-4-M12X2-5POL-R
- CPX-AB-8-KL-4POL
- CPX-AB-1-SUB-BU-25POL
- CPX-AB-4-M12X2-5P-R-M3
- CPX-M-AB-4-M12X2-5POL

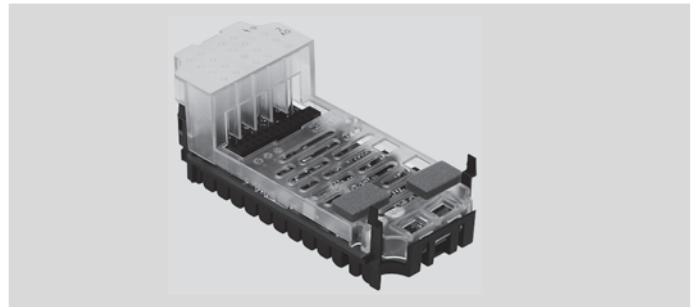

Technical data		Download CAD data → www.festo.com	
Type		CPX-2AA-U-I	
		Voltage output	Current output
Number of outputs		2	2
Max. actuator supply per module	[A]	2.8	2.8
Fuse protection		Internal electronic fuse for actuator supply	
Current consumption from 24 V sensor supply (at full load)	[mA]	Max. 150	Max. 150
Current consumption from 24 V actuator supply (at full load)	[A]	4 ... 10	4 ... 10
Supply voltage for actuators	[V DC]	24 ±25%	24 ±25%
Signal range (parameterisable for each channel by means of DIL switch or software)		0 ... 10 V DC	0 ... 20 mA 4 ... 2 mA
Resolution		12 bits	12 bits
Absolute accuracy	[%]	±0.6	±0.6
Encoder selection	Load resistance for ohmic load	[kΩ]	Min. 1
	Load resistance for capacitive load	[μF]	Max. 1
	Load resistance for inductive load	[mH]	–
	Short circuit protection for analogue output		Yes
	Short circuit current of analogue output	[mA]	Approx. 20
	Open circuit voltage	[V DC]	–
	Destruction limit against externally applied voltage	[V DC]	15
	Actuator connection		2 wires
Response time	For ohmic load	[ms]	0.1
	For capacitive load	[ms]	0.7
	For inductive load	[ms]	–
Data format		15 bits + prefix, linear scaling 12 bits left-aligned, S7 compatible 12 bits left-aligned, S5 compatible	
Cable length	[m]	Max. 30 (screened)	
Parameterisation		Short circuit monitoring, actuator supply	
		Short circuit monitoring, analogue output	
		Behaviour after short circuit, actuator supply	
		Data format	
		Lower limit value/full-scale value	
		Upper limit value/full-scale value	
		Monitoring of value falling below nominal range/full-scale value	
		Monitoring of value exceeding nominal range/full-scale value	
		Wire break monitoring	
		Signal range	

Terminal CPX

Technical data – PROFIsafe shut-off module, CPX-FVDA-P/CPX-FVDA-P2

CPX-FVDA-P

Possible connection blocks:

- CPX-M-AB-4-M12x2-5POL

Possible interlinking blocks:

- CPX-M-GE-EV-FVO

Possible bus nodes:

- CPX-FB33
- CPX-M-FB34
- CPX-M-FB35

CPX-FVDA-P2

Possible connection blocks:

- CPX-M-AB-4-M12x2-5POL
- CPX-AB-8-KL-4POL

Possible interlinking blocks:

- CPX-M-GE-EV-FVO

Possible bus nodes:

- CPX-FB6
- CPX-FB33
- CPX-M-FB34
- CPX-M-FB35



Technical data		Download CAD data → www.festo.com	
Type		CPX-FVDA-P	CPX-FVDA-P2
Number of outputs		2	
Note on outputs		1 internal channel for shutting off the supply voltage for valves 2 external outputs	
Max. power supply	Per module	[A]	5
	Per channel	[A]	0.5 (12 W lamp load) 1.5
Fuse protection (short circuit)		Internal electronic fuse per channel	
Current consumption of module		[mA]	Typically 65 (power supply for valves)
		[mA]	Typically 25 (power supply for electronics)
Voltage drop per channel		[V]	0.6
Residual ripple		[Vss]	2 within voltage range
Load capacity to FE		[nF]	100 400
Max. response time to shut-off command		[ms]	16 23
Electrical isolation	Channel – channel		No
	Channel – internal bus		Yes, with intermediate supply
Switching logic	Outputs		P-M switching
Safety integrity level			Safe shut off, SIL3
Performance Level			Safe shut off/category 3, Performance Level e
Diagnostics			Short circuit/overload per channel
			Undervoltage at valves
			Cross circuit
			Wire break per channel
Parameterisation			Wire break monitoring per channel
			Diagnostic behaviour
Length/width/height (incl. interlinking block and connection block)	[mm]	107 x 50 x 50	107 x 50 x 55

Technical data – Interlinking block without supply, CPX-M-GE-EV-FVO

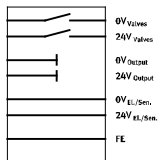

Possible modules:

- CPX-FVDA-P
- CPX-FVDA-P2



Technical data		Download CAD data → www.festo.com	
Type		CPX-M-GE-EV-FVO	
Acceptable current load (per contact/contact rail)	[A]	16	
Type of mounting		Angled fitting	
Length/width/height	[mm]	107 x 50 x 35	

Technical data – Interlinking block with system supply, CPX-GE-EV-S, CPX-M-GE-EV-S

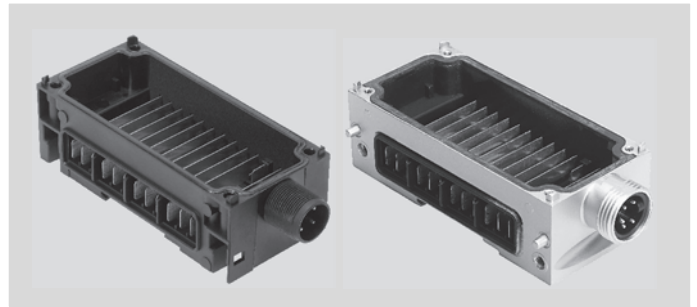
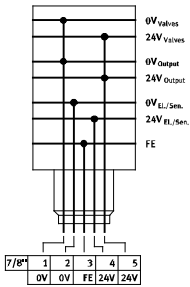

Technical data			Download CAD data → www.festo.com				
Type			CPX-GE-EV-S	CPX-GE-EV-S-7/8-4POL	CPX-GE-EV-S-7/8-5POL	CPX-M-GE-EV-S-7/8-5POL	CPX-M-GE-EV-S-PP-5POL
Electrical connection			M18	7/8", 4-pin	7/8", 5-pin	7/8", 5-pin	AIDA push-pull, 5-pin
Nominal operating voltage	[V DC]		24				
Current supply	Sensors and electronics	[A]	Max. 16		Max. 12	Max. 8	Max. 16
	Valves and outputs	[A]	Max. 16		Max. 12	Max. 8	Max. 16
Protection class to EN 60529			Depending on connection block				
Ambient temperature	[°C]		-5 ... +50				
Type of mounting			Tie rod			Angled fitting	
Length/width/height	[mm]		107/50/35				

Technical data – Interlinking block without supply, CPX-GE-EV, CPX-M-GE-EV

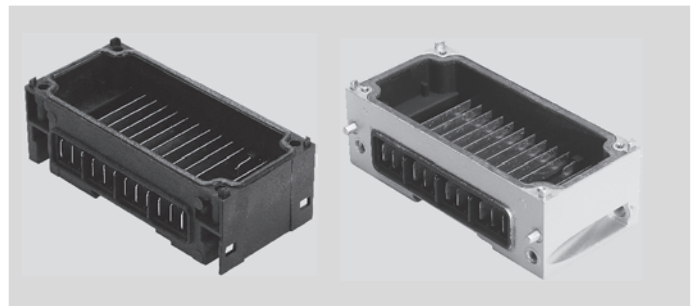
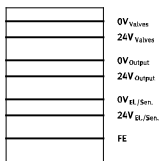

Technical data			Download CAD data → www.festo.com	
Type			CPX-GE-EV	CPX-M-GE-EV
Electrical connection			-	
Nominal operating voltage	[V DC]		24	
Acceptable current load (per contact/contact rail)	[A]		16	
Protection class to EN 60529			Depending on connection block	
Ambient temperature	[°C]		-5 ... +50	
Type of mounting			Tie rod	
Length/width/height	[mm]		107/50/35	

Terminal CPX

Technical data – Interlinking block with additional power supply for outputs, CPX-GE-EV-Z, CPX-M-GE-EV-Z

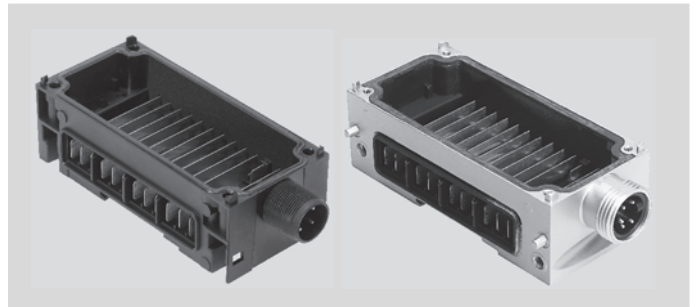
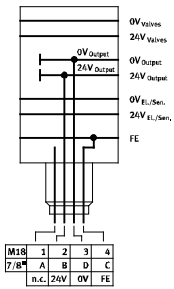

Technical data

Download CAD data → www.festo.com

Type	CPX-GE-EV-Z	CPX-GE-EV-Z-7/8-4POL	CPX-GE-EV-Z-7/8-5POL	CPX-M-GE-EV-Z-7/8-5POL	CPX-M-GE-EV-Z-PP-5POL
Electrical connection	M18	7/8", 4-pin	7/8", 5-pin	7/8", 5-pin	AIDA push-pull, 5-pin
Nominal operating voltage [V DC]	24				
Current supply [A]	Max. 16		Max. 12	Max. 8	Max. 16
Protection class to EN 60529	Depending on connection block				
Ambient temperature [°C]	-5 ... +50				
Type of mounting	Tie rod			Angled fitting	
Length/width/height [mm]	107/50/35				

Technical data – Interlinking block with additional power supply for valves, CPX-GE-EV-V

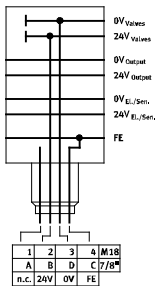

Technical data

Download CAD data → www.festo.com

Type	CPX-GE-EV-V	CPX-GE-EV-V-7/8-4POL
Electrical connection	M18	7/8", 4-pin
Nominal operating voltage [V DC]	24	
Acceptable current load (per contact/contact rail) [A]	16	
Protection class to EN 60529	Depending on connection block	
Ambient temperature [°C]	-5 ... +50	
Type of mounting	Tie rod	
Length/width/height [mm]	107/50/35	

Technical data – Pneumatic interface for valve terminal MPA-S, VMPA-FB-EPL

-  - Operating voltage
24 V DC



Technical data		Download CAD data → www.festo.com	
Type		VMPA-FB-EPL	VMPA-FB-EPLM
Type of mounting		Tie rod	Angled fitting
Number of solenoid coils		128	
Max. intrinsic current consumption per electronics module at 24 V	[mA]	20 (regardless of the switching status of the valves)	
Max. intrinsic current consumption at 24 V (regardless of the switching status of the valves) per electronics module			
VMPA1-FB-EMS-8 or VMPA2-FB-EMS-4	[mA]	3 not galvanically isolated (max. signal line length 10 m)	
VMPA1-FB-EMG-8 or VMPA2-FB-EMG-4	[mA]	23 galvanically isolated	
Diagnostic message on undervoltage U_{OFF} Load voltage outside function range	[V]	17.5 ... 16	
Nominal pick-up current/duration per solenoid coil at nominal voltage	MPA1	[mA]	58/24 ms
	MPA2	[mA]	99/24 ms
Nominal current per solenoid coil at nominal voltage with current reduction	MPA1	[mA]	9 after 24 ms
	MPA2	[mA]	18 after 24 ms
Length/width/height	[mm]	107/51/55	

Technical data – Pneumatic interface for valve terminal MPA-L, VMPAL-EPL-CPX

-  - Operating voltage
24 V DC



Technical data		Download CAD data → www.festo.com	
Type		VMPAL-EPL-CPX	
Type of mounting		Tie rod	
Number of solenoid coils		32	
Operating pressure	[bar]	-0.9 ... 10	
Intrinsic current consumption of valve terminal (internal electronics, without valves)	At 24 V $U_{EL/SEN}$ ¹⁾	[mA]	Typically 13
	At 24 V U_{val} ²⁾	[mA]	Typically 35
Diagnostic message on undervoltage U_{OFF} Load voltage outside function range	[V]	17.7 ... 17.8	
Nominal pick-up current/duration per solenoid coil at nominal voltage	[mA]	50/20 ms	
Nominal current per solenoid coil at nominal voltage with current reduction	[mA]	10 after 20 ms	
Length/width/height	[mm]	107/40/70	

- 1) Power supply for electronics and sensors
2) Load voltage supply for valves

Technical data – Pneumatic interface for valve terminal VTSA/VTSA-F, VABA-S6-1-X

-  - Operating voltage
24 V DC



Technical data		Download CAD data → www.festo.com	
Type		VABA-S6-1-X1	VABA-S6-1-X2
Type of mounting		Tie rod	Angled fitting
Number of solenoid coils		32	
Electrical actuation		Fieldbus	
Electrical connection		Via CPX	
Nominal operating voltage	[V DC]	24	
Permissible voltage fluctuations	[%]	10	
Protection class to EN 60529		IP65	
Ambient temperature	[°C]	-5 ... +50	

Accessories

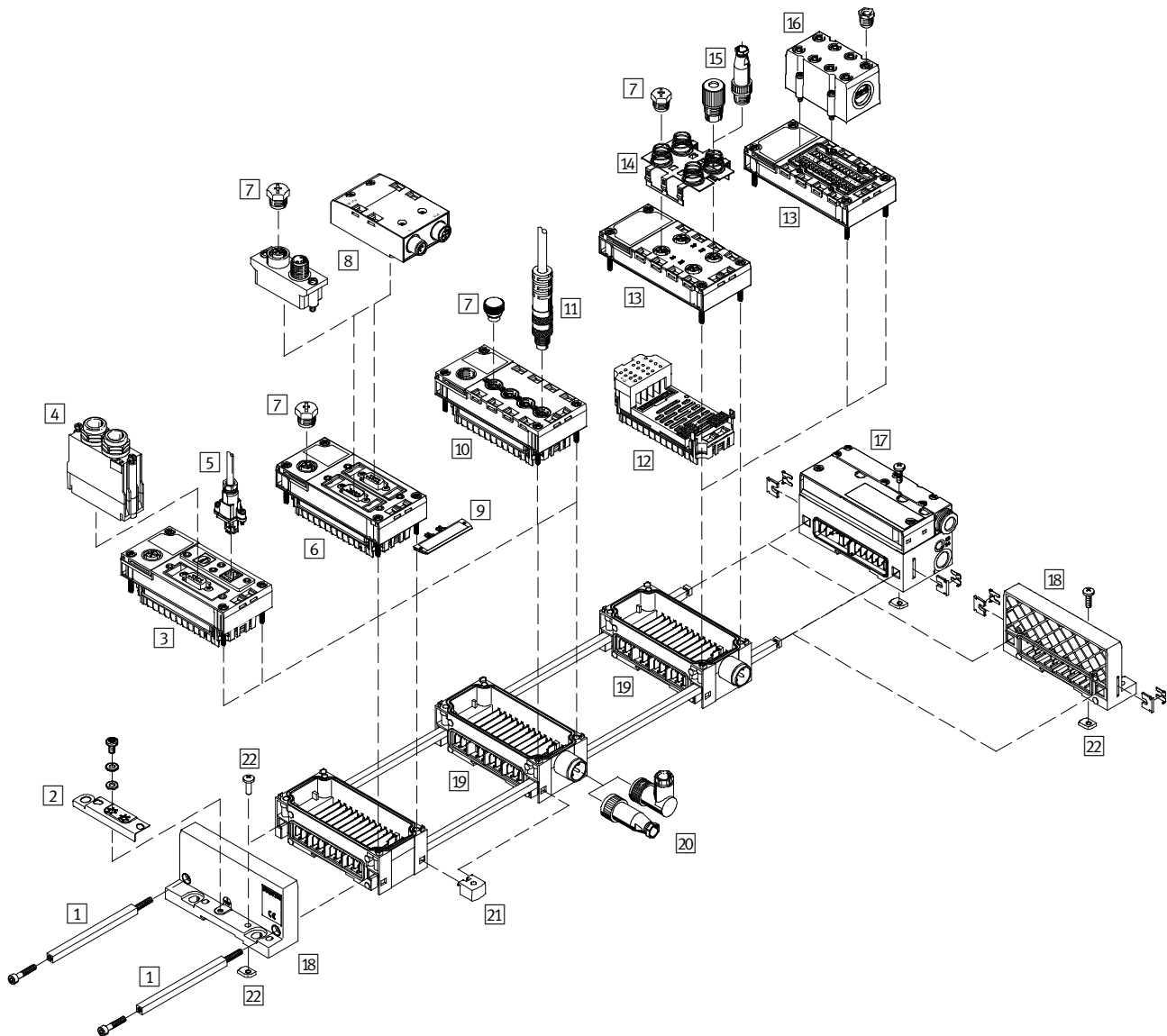





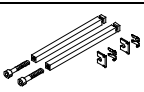
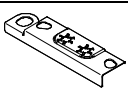
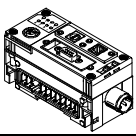
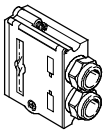
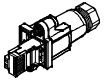
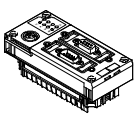

		→ Page/ online			→ Page/ online
1	Tie rod/tie-rod extension CPX-ZA	712	15	Connector plug/connecting cable KM12/NEBU/KM8/KV-M12 for inputs/outputs	715
2	Earthing component CPX-EPFE-EV for right-hand/left-hand end plate	712	16	Cover AK-8KL for CPX-AB-8-KL-4POL (IP65/67)	715
3	Control block CPX-FEC-1-IE/CPX-CEC	712	17	Pneumatic interface VMPA-FB-EPL/VABA-S6-1-X	716
4	Plug FBS-SUB-9 for fieldbus connection (version dependent on bus type)	712	18	End plate CPX-EP	716
5	Plug FBS-RJ45 for Ethernet connection	712	19	Interlinking block CPX-GE/CPX-M-GE (with/without voltage supply)	716
6	CPX bus node CPX-FB	712	20	Connector plug NTSD/NECU for voltage supply	717
7	Cover cap ISK/CPX-M-AK/AK-SUB (for unused connections)	713	21	Mounting components CPX-BG-RW/CPX-M-BG-RW for wall mounting	717
8	Connector plug FBA/FBS/NECU/FBSD/CPX-AB for fieldbus connection	713	22	H-rail mounting CPX-CPA-BG-NRH	717
9	Inscription label IBS/CPX-ST	714	-	Hood CAFC	717
10	CPX CP interface/CPX CTEL master/axis interface CPX-CP-4-FB/CPX-CTEL-4-M12-5POL/CPX-CM	714	-	Screws for mounting the bus node/connection block on an interlinking block	717
11	Connecting cable KVI-CP-3/NEBU-M12G5 for CP interface/CPX CTEL master	714	-	Temperature sensor CPX-W-PT1000 for CPX module CPX-4AE-TC for cold-junction compensation	717
12	CPX module CPX (analogue/digital input/output module)	714	-	Memory card CPX-SK-2 for PROFINET bus node	717
13	Connection block CPX-AB/CPX-M-AB	715	-	User documentation P.BE-CPX	718
14	Screening plate CPX-AB-S	715			

Accessories – Ordering data

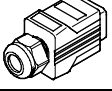
	Description		Part No.	Type
1 Tie rod/tie-rod extension				
	Extension, 1 module	★	525418	CPX-ZA-1-E
	1 module	★	195718	CPX-ZA-1
	2 modules		195720	CPX-ZA-2
	3 modules		195722	CPX-ZA-3
	4 modules		195724	CPX-ZA-4
	5 modules		195726	CPX-ZA-5
	6 modules		195728	CPX-ZA-6
	7 modules		195730	CPX-ZA-7
	8 modules		195732	CPX-ZA-8
	9 modules		195734	CPX-ZA-9
10 modules		195736	CPX-ZA-10	
2 Earthing component for right-hand/left-hand end plate				
	5 pieces		538892	CPX-EPFE-EV
3 Control block CPX-FEC/CPX-CEC Technical data → 688				
	With Ethernet interface RJ45		529041	CPX-FEC-1-IE
	CoDeSys Embedded Controller, CANopen		567347	CPX-CEC-C1
	CoDeSys Embedded Controller, SoftMotion		567348	CPX-CEC-M1
4 Plug for fieldbus connection, Sub-D Technical data online: → fbs				
	For INTERBUS, incoming		532218	FBS-SUB-9-BU-IB-B
	For INTERBUS, outgoing		532217	FBS-SUB-9-GS-IB-B
	For DeviceNet/CANopen		532219	FBS-SUB-9-BU-2x5POL-B
	For PROFIBUS DP		532216	FBS-SUB-9-GS-DP-B
	For CC-Link		532220	FBS-SUB-9-GS-2x4POL-B
	For control block		534497	FBS-SUB-9-GS-1x9POL-B
5 Ethernet connection Technical data online: → fbs				
	RJ45 plug		534494	FBS-RJ45-8-GS
6 CPX bus node Technical data → 692				
	INTERBUS		195748	CPX-FB6
	DeviceNet		526172	CPX-FB11
	PROFIBUS DP	★	195740	CPX-FB13
	CANopen		526174	CPX-FB14
	CC-Link		526176	CPX-FB23-24
	Ethernet/IP with M12		541302	CPX-FB32
	PROFINET with M12, D-coded, 4-pin		548755	CPX-FB33
	PROFINET with RJ45 push-pull, AIDA		548751	CPX-M-FB34
	PROFINET with SCRJ push-pull, AIDA		548749	CPX-M-FB35
	Bus node for EtherCAT		552046	CPX-FB38

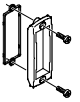

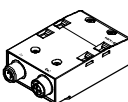

9

Accessories – Ordering data

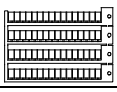
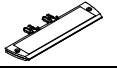

	Description	Part No.	Type
7 Cover cap			
	For M8 connections (packaging unit 10 pieces)	177672	ISK-M8
	For M12 connections (packaging unit 10 pieces)	165592	ISK-M12
	Cover cap for bus connection	548753	CPX-M-AK-C
	Cover for DIL switch and memory card	548754	CPX-M-AK-M
	Inspection cover, for DIL switch and bus connection	Transparent	533334 AK-SUB-9/15-B
		Black	557010 AK-SUB-9/15
8 Connector plug for fieldbus connection			Technical data online: necu
	M12 adapter (B-coded) for PROFIBUS DP	533118	FBA-2-M12-5POL-RK
	Micro style, 2x M12 for DeviceNet/CANopen	525632	FBA-2-M12-5POL
	Socket for micro style connection, M12	18324	FBSD-GD-9-5POL
	Plug for micro style connection, M12	175380	FBS-M12-5GS-PG9
	Plug M12x1, 4-pin, D-coded, for PROFINET	543109	NECU-M-S-D12G4-C2-ET
	Socket M12x1, for FBA-2-M12-5POL-RK and CPX-AB-2-M12-RK-DP	1067905	NECU-M-B12G5-C2-PB
	Plug M12x1, for FBA-2-M12-5POL-RK and CPX-AB-2-M12-RK-DP	1066354	NECU-M-S-B12G5-C2-PB
	RJ45 plug, 8-pin, push-pull	552000	FBS-RJ45-PP-GS
	SCRJ plug, 2-pin, push-pull	571017	FBS-SCRJ-PP-GS
8 Connector plug for fieldbus connection			
	M12 adapter for PROFIBUS DP (B-coded)	541519	CPX-AB-2-M12-RK-DP
	M12 adapter for INTERBUS (B-coded)	534505	CPX-AB-2-M12-RK-IB
	Open style for 5-pin terminal strip, for DeviceNet/CANopen	525634	FBA-1-SL-5POL
	5-pin terminal strip, for DeviceNet/CANopen	525635	FBSD-KL-2x5POL
	Screw terminal for CC-Link	197962	FBA-1-KL-5POL

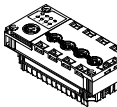
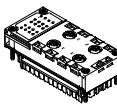
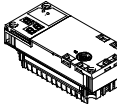
Terminal CPX

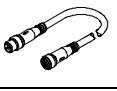
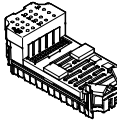
Accessories – Ordering data

	Description	Part No.	Type
9 Inscription label			
	Inscription labels 6x10 mm, in frame (64 pieces)	18576	IBS-6x10
	Inscription label holder for connection block M12	536593	CPX-ST-1
	Screws for attaching an inscription label holder to the bus node (12 pieces)	550222	CPX-M-M2,5X8-12X
10 CPX CP interface/axis interface Technical data → 695			
	Central node for connecting I/O modules of the CPI system	526705	CPX-CP-4-FB
	Interface for max. 4 I/O modules and valve terminals with I-Port interface (devices)	1577012	CPX-CTEL-4-M12-5POL
	FHPP gateway	562214	CPX-CM-HPP
11 Connecting cable Technical data online: → kvi			
For CP interface, M9-M9			
	Angled plug/angled socket	0.25 m	540327 KVI-CP-3-WS-WD-0,25
		0.5 m	540328 KVI-CP-3-WS-WD-0,5
		2 m	540329 KVI-CP-3-WS-WD-2
		5 m	540330 KVI-CP-3-WS-WD-5
		8 m	540331 KVI-CP-3-WS-WD-8
	Straight plug/straight socket	2 m	540332 KVI-CP-3-GS-GD-2
		5 m	540333 KVI-CP-3-GS-GD-5
		8 m	540334 KVI-CP-3-GS-GD-8
For CPX CTEL master, M12-M12 Technical data → 949			
	Straight plug/straight socket	5 m	574321 NEBU-M12G5-E-5-Q8N-M12G5
		7.5 m	574322 NEBU-M12G5-E-7.5-Q8N-M12G5
		10 m	574323 NEBU-M12G5-E-10-Q8N-M12G5
12 CPX module Technical data → 697			
	8 digital inputs PNP	★	195750 CPX-8DE
	8 digital inputs NPN		543813 CPX-8NDE
	16 digital inputs		543815 CPX-16DE
	16 digital inputs with channel diagnostics	★	550202 CPX-M-16DE-D
	4 digital outputs		195754 CPX-4DA
	8 digital outputs		550204 CPX-8DA-H
	8 digital inputs and 8 digital outputs		526257 CPX-8DE-8DA
	2 analogue inputs		526168 CPX-2AE-U-I
	4 analogue inputs		541484 CPX-4AE-I
	4 analogue inputs for temperature measurement		541486 CPX-4AE-T
	4 analogue inputs for temperature measurement, thermocoupler and PT1000 sensor for cold-junction compensation		553594 CPX-4AE-TC
	Input module, 4 analogue inputs (pressure), pressure range -1 ... +1 bar		560361 CPX-4AE-P-B2
	Input module, 4 analogue inputs (pressure), pressure range 0 ... 10 bar		560362 CPX-4AE-P-D10
	2 analogue outputs		526170 CPX-2AA-U-I
	PROFIsafe shut-off module	PROFINET	
PROFINET, PROFIBUS			1971599 CPX-FVDA-P2

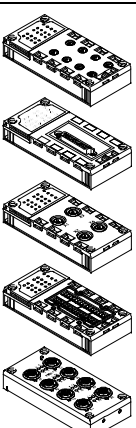
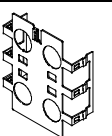
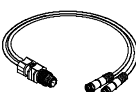
Accessories – Ordering data

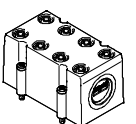



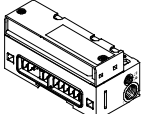
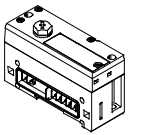
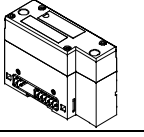
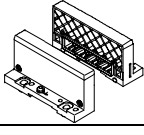
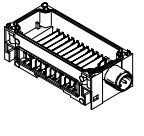
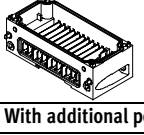
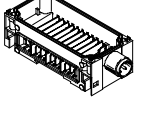
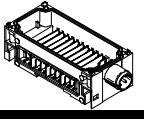



	Description	Part No.	Type
13 Connection block			
	Plastic design with mounting screws for assembly on plastic interlinking blocks		
	8 connections M8, 3-pin	★	195706 CPX-AB-8-M8-3POL
	8 connections M8, 4-pin		541256 CPX-AB-8-M8X2-4POL
	4 connections M12, 5-pin	★	195704 CPX-AB-4-M12x2-5POL
	4 connections M12, 5-pin, with quick lock and metal thread		541254 CPX-AB-4-M12x2-5POL-R
	8 spring-loaded terminal connections, 4-pin	★	195708 CPX-AB-8-KL-4POL
	Sub-D socket, 25-pin		525676 CPX-AB-1-SUB-BU-25POL
	4 connections in HARAX fast connection technology, 4-pin		525636 CPX-AB-4-HAR-4POL
	Metal design with mounting screws for assembly on metal and plastic interlinking blocks		
	4 connections M12, 5-pin		549367 CPX-M-AB-4-M12x2-5POL
	8 connections M12, 5-pin	★	549335 CPX-M-AB-8-M12x2-5POL
	14 Screening plate		
	For M12 connections	526184	CPX-AB-S-4-M12
15 Connector plug/connecting cable for inputs/outputs, DUO connecting cable M12, 4-pin			
			Technical data online: → km12
	2x straight socket	18685	KM12-DUO-M8-GDGD
	2x straight/angled socket	18688	KM12-DUO-M8-GDWD
	2x angled socket	18687	KM12-DUO-M8-WDWD
Connecting cable			
			Technical data → 949
	M8-M8 3-pin/3-pin	0.5 m	175488 KM8-M8-GSGD-0,5
		1.0 m	175489 KM8-M8-GSGD-1
		2.5 m	165610 KM8-M8-GSGD-2,5
		5.0 m	165611 KM8-M8-GSGD-5
	M12-M12 5-pin/5-pin	1.5 m	529044 KV-M12-M12-1,5
		3.5 m	530901 KV-M12-M12-3,5
	M12-M12 4-pin/4-pin	2.5 m	18684 KM12-M12-GSGD-2,5
		5.0 m	18686 KM12-M12-GSGD-5
	1.0 m	185499 KM12-M12-GSWD-1-4	
Connecting cable M9, 5-pin			
			Technical data online: → nebc
	M9/open end	2.0 m	563711 NEBC-M9W5-K-2-N-LE3
	5-pin/3-wire	5.0 m	563712 NEBC-M9W5-K-5-N-LE3
16 Cover for CPX-AB-8-KL-4POL (IP65/67)			
	- 8 cable through-feeds M9 - 1 cable through-feed for multi-pin plug	★	538219 AK-8KL
	Fittings kit for cover AK-8KL	★	538220 VG-K-M9

Accessories – Ordering data

	Description	Part No.	Type
17 Pneumatic interface, for valve terminal MPA-S, CPX in plastic design Technical data → 709			
	Internal pilot air supply	533370	VMPA-FB-EPL-G
	External pilot air supply	533369	VMPA-FB-EPL-E
	Internal pilot air supply, flat plate silencer	533372	VMPA-FB-EPL-GU
	External pilot air supply, flat plate silencer	533371	VMPA-FB-EPL-EU
For valve terminal MPA-L			
	CPX in plastic design	★ 570783	VMPAL-EPL-CPX
For valve terminal VTSA/VTSA-F			
	CPX in plastic design	543416	VABA-S6-1-X1
	CPX in metal design	550663	VABA-S6-1-X2
18 End plates			
	Plastic design	Right-hand	195714 CPX-EPR-EV
		Left-hand	★ 195716 CPX-EPL-EV
	Metal design	Right-hand	550214 CPX-M-EPR-EV
		Left-hand	550212 CPX-M-EPL-EV
19 Interlinking block, with system supply Technical data → 707			
	Plastic design	M18 connection	★ 195746 CPX-GE-EV-S
		7/8" connection, 4-pin	541248 CPX-GE-EV-S-7/8-4POL
		7/8" connection, 5-pin	541244 CPX-GE-EV-S-7/8-5POL
	Metal design	7/8" connection, 5-pin	550208 CPX-M-GE-EV-S-7/8-5POL
		Push-pull plug connection (AIDA), 5-pin	563057 CPX-M-GE-EV-S-PP-5POL
Without supply			
	Plastic design	★ 195742	CPX-GE-EV
	Metal design	★ 550206	CPX-M-GE-EV
	Metal design, for CPX-FVDA-P	567806	CPX-M-GE-EV-FVO
With additional power supply for outputs			
	Plastic design	M18 connection	195744 CPX-GE-EV-Z
		7/8" connection, 4-pin	541250 CPX-GE-EV-Z-7/8-4POL
		7/8" connection, 5-pin	541246 CPX-GE-EV-Z-7/8-5POL
	Metal design	7/8" connection, 5-pin	550210 CPX-M-GE-EV-Z-7/8-5POL
		Push-pull plug connection (AIDA), 5-pin	563058 CPX-M-GE-EV-Z-PP-5POL
With additional power supply for valves			
	Plastic design	M18 connection	533577 CPX-GE-EV-V
		7/8" connection, 4-pin	541252 CPX-GE-EV-V-7/8-4POL

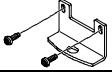
9

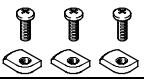
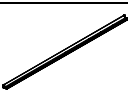
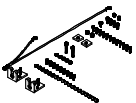
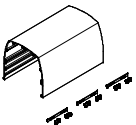
Accessories – Ordering data

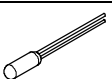
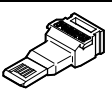
	Description		Part No.	Type
20 Connector plug for power supply Technical data online: → ntsd				
	M18 socket, straight	For 1.5 mm ²	18493	NTSD-GD-9
		For 2.5 mm ²	18526	NTSD-GD-13,5
	M18 socket, angled	For 1.5 mm ²	18527	NTSD-WD-9
		For 2.5 mm ²	533119	NTSD-WD-11
	7/8" connection	5-pin	543107	NECU-G78G5-C2
		4-pin	543108	NECU-G78G4-C2
	AIDA push-pull plug socket, spring-loaded terminal	5-pin	563059	NECU-M-PPG5-C1
21 Attachment for wall mounting				
	For long valve terminals, 10 pieces, for plastic manifold sub-bases	★	529040	CPX-BG-RW-10x
	For long valve terminals, 2 mounting brackets and 4 screws, for metal manifold sub-bases		550217	CPX-M-BG-RW-2x
	Retainer for operator unit CPX-MMI-1		534705	CPX-MMI-1-H
	Mounting for H-rail for operator unit CPX-MMI-1		536689	CPX-MMI-1-NRH
22 H-rail mounting				
	For mounting CPX terminal and valve terminal on H-rail	★	526032	CPX-CPA-BG-NRH
Hood				
	Mounting rail for attaching the hood, 1 m		572256	CAFC-X1-S
	Mounting kit for CPX hood		572257	CAFC-X1-BE
	Hood section	200 mm	572258	CAFC-X1-GAL-200
		300 mm	572259	CAFC-X1-GAL-300
Screws for mounting the bus node/connection block on an interlinking block				
	Metal connection block, plastic interlinking block		550218	CPX-DPT-30X32-S-4X
	Plastic connection block, metal interlinking block		550219	CPX-M-M3x22-4x
	Metal connection block, metal interlinking block	★	550216	CPX-M-M3x22-S-4x
Temperature sensor				
	PT1000, for cold-junction compensation for CPX module CPX-4AE-TC		553596	CPX-W-PT1000
Memory card				
	For PROFINET bus node (CPX-FB33, CPX-M-FB34, CPX-M-FB35), 2MB		568647	CPX-SK-2

Accessories – Ordering data

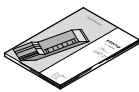
	Description	Part No.	Type
Manual			
	Bus node CPX-FB06		
	German	526433	P.BE-CPX-FB6-DE
	English	526434	P.BE-CPX-FB6-EN
	French	526436	P.BE-CPX-FB6-FR
	Italian	526437	P.BE-CPX-FB6-IT
	Spanish	526435	P.BE-CPX-FB6-ES
	Swedish	526438	P.BE-CPX-FB6-SV
	Bus node CPX-FB11		
	German	526421	P.BE-CPX-FB11-DE
	English	526422	P.BE-CPX-FB11-EN
	French	526424	P.BE-CPX-FB11-FR
	Italian	526425	P.BE-CPX-FB11-IT
	Spanish	526423	P.BE-CPX-FB11-ES
	Swedish	526426	P.BE-CPX-FB11-SV
	Bus node CPX-FB13		
	German	526427	P.BE-CPX-FB13-DE
	English	526428	P.BE-CPX-FB13-EN
	French	526430	P.BE-CPX-FB13-FR
	Italian	526431	P.BE-CPX-FB13-IT
	Spanish	526429	P.BE-CPX-FB13-ES
	Swedish	526432	P.BE-CPX-FB13-SV
	Bus node CPX-FB14		
	German	526409	P.BE-CPX-FB14-DE
	English	526410	P.BE-CPX-FB14-EN
	French	526412	P.BE-CPX-FB14-FR
	Italian	526413	P.BE-CPX-FB14-IT
	Spanish	526411	P.BE-CPX-FB14-ES
	Swedish	526414	P.BE-CPX-FB14-SV
	Bus node CPX-FB23-24		
	German	526403	P.BE-CPX-FB23-24-DE
	English	526404	P.BE-CPX-FB23-24-EN
	Bus node CPX-FB32		
	German	541304	P.BE-CPX-FB32-DE
	English	541305	P.BE-CPX-FB32-EN
	Spanish	541306	P.BE-CPX-FB32-ES
	Bus node CPX-FB33, CPX-M-FB34, CPX-M-FB35		
	German	548759	P.BE-CPX-PNIO-DE
	English	548760	P.BE-CPX-PNIO-EN
	Spanish	548761	P.BE-CPX-PNIO-ES
	Bus node CPX-FB38		
	German	562524	P.BE-CPX-FB38-DE
	English	562525	P.BE-CPX-FB38-EN
	Spanish	562526	P.BE-CPX-FB38-ES

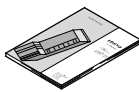
	Description	Part No.	Type
Manual			
	CPX system manual		
	German	526445	P.BE-CPX-SYS-DE
	English	526446	P.BE-CPX-SYS-EN
	Spanish	526447	P.BE-CPX-SYS-ES
	French	526448	P.BE-CPX-SYS-FR
	Italian	526449	P.BE-CPX-SYS-IT
	Swedish	526450	P.BE-CPX-SYS-SV
	Operator unit CPX-MMI-1		
	German	534824	P.BE-CPX-MMI-1-DE
	English	534825	P.BE-CPX-MMI-1-EN
	French	534827	P.BE-CPX-MMI-1-FR
	Italian	534828	P.BE-CPX-MMI-1-IT
	Swedish	534829	P.BE-CPX-MMI-1-SV
	Spanish	534826	P.BE-CPX-MMI-1-ES
	CPX CP interface		
	German	539293	P.BE-CPX-CP-DE
	English	539294	P.BE-CPX-CP-EN
	Spanish	539295	P.BE-CPX-CP-ES
	CPX CTCL master		
	German	574600	P.BE-CPX-CTCL-DE
	English	574601	P.BE-CPX-CTCL-EN
	Spanish	574602	P.BE-CPX-CTCL-ES
	Control block CPX-CM-HPP		
	German	568683	P.BE-CPX-CM-HPP-DE
	English	568684	P.BE-CPX-CM-HPP-EN
	PROFIsafe shut-off module		
	German	570843	P.BE-CPX-FVDA-P-DE
	English	570844	P.BE-CPX-FVDA-P-EN
	Spanish	570845	P.BE-CPX-FVDA-P-ES
	French	570846	P.BE-CPX-FVDA-P-FR
	Italian	570847	P.BE-CPX-FVDA-P-IT
	Swedish	570848	P.BE-CPX-FVDA-P-SV
	Digital input/output modules		
	German	526439	P.BE-CPX-EA-DE
	English	526440	P.BE-CPX-EA-EN
	Spanish	526441	P.BE-CPX-EA-ES
	Analogue input/output modules		
	German	526415	P.BE-CPX-AX-DE
	English	526416	P.BE-CPX-AX-EN
	Spanish	526417	P.BE-CPX-AX-ES



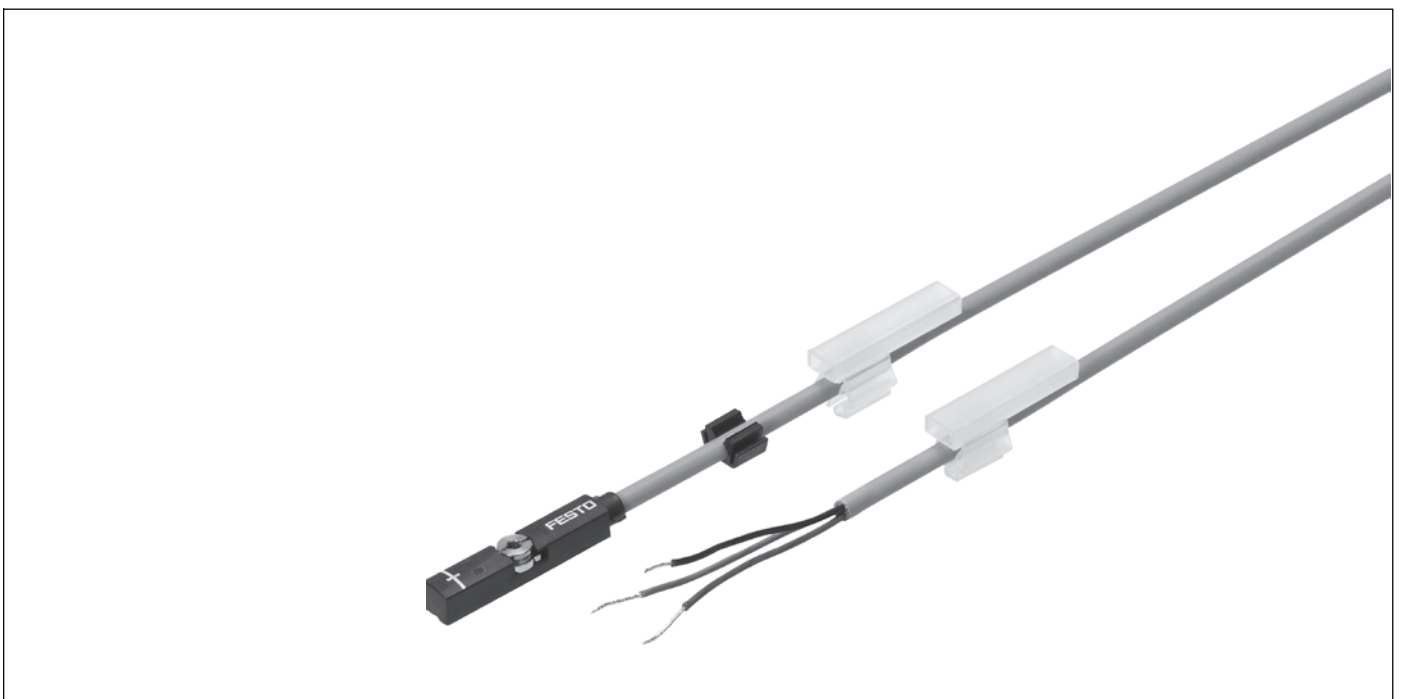

10 Sensors

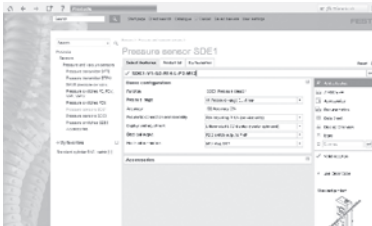





Software tool

Configurator		<p>Design a product with numerous features reliably and quickly with the help of the configurator. Select all the required product features step-by-step. The use of logic checks ensures that only correct configurations are available for selection.</p>	<p>The configurator is part of the electronic catalogue and is not available as a separate software program.</p>
--------------	---	---	--



Proximity sensors, for T-slot

Type	 Proximity sensor SME-8, SME-8M, SME-8-SL, SME-8-FM	 Proximity sensor SMT-8M-A	 Proximity sensor SMT-8F, SMT-8G, SMT-8-SL	 Proximity sensor CRSMT-8
Electrical connection	2-wire, 3-wire, 3-pin, cable, cable with plug, M8x1, snap collar, plug, rotatable thread, open end	2-wire, 3-wire, 2-pin, 3-pin, cable, cable with plug, M8x1, M12x1, snap collar, rotatable thread	2-wire, 3-wire, 3-pin, cable, cable with plug, M8x1, plug, rotatable thread	3-wire, cable
Operating voltage range DC	0 ... 230 V	5 ... 30 V	10 ... 30 V	10 ... 30 V
Switching element function	N/O contact, N/C contact	N/C contact, N/C contact or N/O contact switchable, N/O contact	NAMUR, N/O contact	N/O contact
Switching output	Contacting, bipolar, without LED function	Non-contacting, 2-wire, NPN, PNP, PNP/NPN switchable	NPN, NAMUR	PNP
Description	<ul style="list-style-type: none"> Measuring principle: magnetic reed Screw-clamped or clamped in slot, insertable in the slot from above or lengthwise Cable length 0.3, 2.5, 5, 7.5, 0.2 ... 10 m Variant suitable for use with energy chains and robots SME-8...-S6: heat-resistant design 	<ul style="list-style-type: none"> Short design Measuring principle: magneto-resistive Insertable in the slot from above, does not protrude over the cylinder profile Variant Ex2 for use in potentially explosive areas Cable length 0.1 ... 30 m 	<ul style="list-style-type: none"> Measuring principle: magneto-resistive Insertable in the slot lengthwise or from above Type SMT-8-F: in accordance with the ATEX directive for explosive atmospheres Type SMT-8-G: design ideally matched to gripper sensing Type SMT-8-SL: sturdy thanks to long guides and plug directly at the sensor Cable length 0.3, 2.5 and 5 m Suitable for use with energy chains and robots 	<ul style="list-style-type: none"> Corrosion-resistant design Suitable for the food industry, resistant to acids and cooling lubricants Measuring principle: magneto-resistive Insertable in the slot lengthwise, flush with the cylinder profile Cable length 2.5, 5 m
→ Page/online	730	737	smt-8	crsmt-8



Proximity sensors, for T-slot

Type	 Proximity sensor SMEO-8E	 Proximity sensor SMTO-8E	 Proximity sensor SMPO-8E	 Proximity sensor SMTSO-8E
Electrical connection	2-wire, 3-pin, cable, M8x1, M12x1, plug	3-pin, M8x1, M12x1, plug		3-pin, M12x1, plug
Operating voltage range DC	0 ... 250 V	10 ... 30 V		10 ... 30 V
Switching element function	N/O contact	N/O contact		N/O contact
Switching output	Contacting, contacting bipolar, without LED function	NPN, PNP		NPN, PNP
Description	<ul style="list-style-type: none"> Sturdy sensor in block design Measuring principle: magnetic reed Cable length 2.5 m Plug integrated in housing LED switching status indication 	<ul style="list-style-type: none"> Sturdy sensor in block design Measuring principle: magneto-resistive Plug integrated in housing LED switching status indication 	<ul style="list-style-type: none"> Pneumatic proximity sensor Measuring principle: magnetic Function: 3/2-way valve, normally closed Pneumatic connection via female thread M5 Visual switching status indication 	<ul style="list-style-type: none"> Sturdy sensor in block design Welding field immune design Measuring principle: magneto-inductive Plug integrated in housing LED switching status indication
→ Page/online	smeo	smto	smpo	smtso



Proximity sensors, for C-slot

Type	 Proximity sensor SME-10, SME-10M	 Proximity sensor SMT-10M, SMT-10G
Electrical connection	2-pin, 3-pin, 3-wire, cable, cable with plug, M12, M8x1, snap collar, plug, rotatable thread, open end	2-pin, 3-pin, 3-wire, cable, cable with plug, M12, M8x1, snap collar, rotatable thread, open end
Operating voltage range DC	5 ... 30 V	10 ... 30 V
Switching element function	N/O contact	NAMUR, N/O contact
Switching output	Contacting, bipolar	NPN, PNP, non-contacting, 2-wire
Description	<ul style="list-style-type: none"> Measuring principle: magnetic reed Clamped in C-slot, insertable in the slot from above or lengthwise Cable length 0.3, 2.5 m 	<ul style="list-style-type: none"> Measuring principle: magneto-resistive Clamped in C-slot, insertable in the slot from above or lengthwise Cable length 0.3, 2.5 m
→ Page/online	744	749

Proximity sensors, round design

Type	 Proximity sensor SMEO-4U	 Proximity sensor CRSMEO-4	 Proximity sensor SMTO-4U
Electrical connection	2-wire, 3-wire, 3-pin, cable, M8x1, M12x1, plug	3-wire, cable	3-wire, 3-pin, cable, M8x1, M12x1, plug
Operating voltage range DC	0 ... 250 V	12 ... 30 V	10 ... 30 V
Switching element function	N/O contact	N/O contact	N/O contact
Switching output	Contacting, contacting bipolar, without LED function	Contacting, bipolar	NPN, PNP
Description	<ul style="list-style-type: none"> Measuring principle: magnetic reed Cable length 2.5, 5 m U-shaped housing 	<ul style="list-style-type: none"> Corrosion-resistant design Measuring principle: magnetic reed Cable length 2.5 m Straight housing 	<ul style="list-style-type: none"> Measuring principle: magneto-inductive Cable length 2.5 m U-shaped housing
→ Page/online	smeo-4	crsmeo-4	smtso-4

Proximity sensors, block design

			
Type	Proximity sensor SMT-C1	Proximity sensor SMEO-1	Proximity sensor SMT0-1
Electrical connection	3-wire, 3-pin, cable, cable with plug, M8x1, M12x1, rotatable thread	2-wire, 3-wire, 3-pin, cable, M8x1, M12x1, plug	3-wire, 3-pin, cable, M8x1, plug
Operating voltage range DC	10 ... 30 V	0 ... 250 V	10 ... 30 V
Switching element function	N/O contact	N/O contact	N/O contact
Switching output	PNP	Contacting, contacting bipolar, without LED function	NPN, PNP
Description	<ul style="list-style-type: none"> Measuring principle: magneto-inductive LED switching status indication For Clean Design standard cylinder DSBF with mounting rail for sensors 	<ul style="list-style-type: none"> Measuring principle: magnetic reed Cable length 2.5, 5 m SMEO-1-S6: heat-resistant design Designs with and without LED switching status indication 	<ul style="list-style-type: none"> Measuring principle: magneto-resistive Cable length 2.5 m LED switching status indication
→ Page/online	smt-c1	smeo-1	smt0-1



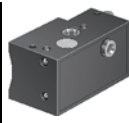

Proximity sensors, block design

		
Type	Proximity sensor SMTSO-1	Proximity sensor SMP0-1
Electrical connection	3-pin, M12x1, plug	
Operating voltage range DC	10 ... 30 V	
Switching element function	N/O contact	
Switching output	PNP	
Description	<ul style="list-style-type: none"> Measuring principle: magneto-resistive Welding field immune design LED switching status indication 	<ul style="list-style-type: none"> 3/2-way valve, normally closed Pneumatic proximity sensor Measuring principle: magnetic Pneumatic connection via barbed connector for tubing I.D. 3 mm Visual switching status indication
→ Page/online	smsto-1	smpto



Cylinder signal generators

	
Type	Cylinder signal generator PPL
Standard nominal flow rate	48 l/min
Operating pressure	1 ... 8 bar
Pneumatic connection	Barbed connector for 3 mm plastic tubing
Type of mounting	Hollow bolt G1/8, hollow bolt G1/4
Description	<ul style="list-style-type: none"> For contactless pneumatic signal generation at the end of cylinder strokes Function: 3/2-way valve, normally closed Can be screwed directly into the supply port of the cylinder using a hollow bolt
→ Page/online	ppl



Inductive sensors

Type	 Proximity sensor SIEA	 Proximity sensor SIED	 Proximity sensor SIEF	 Proximity sensor SIEH
Size	M8, M12, M18, M30	M12, M18, M30	40x40x65 mm, M8, M12, M18, M30	3 mm, M12, M18
Switching output		Non-contacting, 2-wire	NPN, PNP	NPN, PNP
Switching element function		N/O contact, N/C contact	Antivalent, N/O contact	N/O contact, N/C contact
Electrical connection	3-pin, 4-pin, M8x1, M12x1, plug	2-wire, 2-pin, cable, M12x1, plug	3-wire, 3-pin, 4-pin, Fixcon, cable, M8x1, M12x1, plug	3-wire, 3-pin, cable, cable with plug, M8x1, M12x1, plug
Operating voltage range DC	15 ... 30 V	10 ... 320 V	10 ... 30 V	10 ... 30 V
Description	<ul style="list-style-type: none"> • With analogue output • Flush mounting • Metric thread 	<ul style="list-style-type: none"> • With standard switching distance • For DC and AC voltage • Metric thread • Flush or non-flush mounting • With switching status indication • Design with metal or polyamide housing 	<ul style="list-style-type: none"> • Reduction factor 1 for all metals • Welding field immune • Flush, partially flush or non-flush mounting • With switching status indication • Design with housing resistant to welding spatter 	<ul style="list-style-type: none"> • With increased switching distance • Flush mounting • Metric thread • With switching status indication • Design with stainless steel housing
→ Page/online	siea	sied	sief	sieh

Inductive sensors

Type	 Proximity sensor SIEN	 Proximity sensor SIES	 Proximity sensor SIES-8M
Size	4 mm, 6.5 mm, M5x0.5, M8x1, M12, M12x1, M18, M18x1, M30, M30x1.5	12x26x40 mm, 15x20x30 mm, 40x40x120 mm, 5x5x25 mm, 8x8x40 mm	T-slot
Switching output	NPN, PNP	NPN, PNP	NPN, PNP
Switching element function	N/O contact, N/C contact	Antivalent, N/O contact, N/C contact	N/O contact, N/C contact
Electrical connection	3-wire, 3-pin, cable, M8x1, M12x1, plug	3-wire, 3-pin, cable, cable with plug, M8x1, screw terminal, plug, rotatable thread	3-wire, 3-pin, cable, cable with plug, M8x1, rotatable thread
Operating voltage range DC	10 ... 30 V	10 ... 30 V	10 ... 30 V
Description	<ul style="list-style-type: none"> • With standard switching distance • For DC voltage • Round design • Metric thread • Flush or non-flush mounting • With switching status indication • Design with metal housing • Design with polyamide housing 	<ul style="list-style-type: none"> • Block design • Flush mounting • With switching status indication 	<ul style="list-style-type: none"> • Suitable for position sensing for electric axes EGC and grippers with T-slot • With 2 LEDs for better visibility • Flush mounting
→ Page/online	755	sies	759



Position sensors

			
Type	Position transmitter SMAT-8E	Position transmitter SMAT-8M	Position sensor SMH-S1
Design	For T-slot	For T-slot	For gripper
Position measuring range	0 ... 50 mm	0 ... 40 mm	
Analogue output	0 ... 10 V, 0 ... 20 mA	0 ... 10 V	
Electrical connection	4-pin, M8x1, plug	4-pin, cable with plug, M8x1, rotatable thread	4-pin, cable with plug, M8x1
Description	<ul style="list-style-type: none"> Measuring principle: magnetic Insertable in the slot lengthwise Current and voltage signal at the analogue output Variant with cable attributes suitable for use with energy chains and robots LED status indication Cable length 2.5 m, 5 m 	<ul style="list-style-type: none"> Measuring principle: magnetic Insertable in the slot from above, central clamping Displacement-proportional analogue output signal Variant with cable attributes suitable for use with energy chains and robots LED status indication Cable length 0.3 m 	<ul style="list-style-type: none"> Measuring principle: magnetic Hall Freely selectable switching points 3 gripper positions can be detected using an evaluation unit
→ Page/online	smat-8e	smat-8m	smh-s1



Pressure and vacuum sensors

				
Type	Pressure switch SPBA	Pressure transmitter SPTe	Pressure transmitter SPTW	Pressure sensor SPAB
Pressure measuring range		-1 ... 10 bar	-1 ... 10 bar	-1 ... 10 bar
Switching element function	Antivalent, changeover switch			Switchable
Pneumatic connection	G1/8	Flange, QS-3, QS-4, push-in sleeve QS-4, push-in sleeve QS-6	G1/4	Male thread G1/8, male thread NPT1/8-27, male thread R1/8, female thread M5
Electrical connection	Plug, to EN 60947-5-2, M12x1, 4-pin, round	3-wire, cable, open end	4-pin, M12x1, plug, to EN 60947-5-2, round design	4-wire, 4-pin, cable, M8x1, plug, to EN 60947-5-2, round design, square design
Display type				Illuminated LCD, multi-colour
Description	<ul style="list-style-type: none"> For solenoid valve VSVA Pressure sensor with permanently set switching point Mounting: screw-in 	<ul style="list-style-type: none"> Piezoresistive pressure sensor Measured variable: relative pressure Cable length 2.5 m 	<ul style="list-style-type: none"> Sensor versions: piezoresistive pressure sensor or metal thin-film pressure sensor Measured variable: relative pressure 	<ul style="list-style-type: none"> Relative pressure measurement Switching output PNP, NPN and analogue output Two-part, multi-coloured display Easy commissioning thanks to intuitive operation Compact design 30x30 mm Certification: c UL us Listed (OL), C-Tick
→ Page/online	spba	spte	sptw	spab



Pressure and vacuum sensors

			
Type	Pressure switch, vacuum switch PEV, VPEV	PE converter PEN, PE, VPE	Pressure sensor SDE1
Pressure measuring range	-1 ... 10 bar	-1 ... 8 bar	-1 ... 10 bar
Switching element function	Changeover switch	N/O contact, changeover switch	Switchable
Pneumatic connection	G1/8, G1/4, M5	G1/8, M5, PK-3, PK-4	G1/8, QS-4, R1/8, R1/4
Electrical connection	4-pin, type A, M8x1, M12x1, screw terminal, plug, to DIN 43650, to EN 60947-5-2, round design, square design	3 cords, 3-wire, 4-wire, cable, screw terminal	3-pin, 4-pin, 5-pin, cable with plug, M8x1, M12x1, plug, to EN 60947-5-2, round design
Display type			Illuminated LCD, back-lit LCD
Description	<ul style="list-style-type: none"> • Mechanical pressure and vacuum switch • Adjustable switching point • Screw-in, via through-holes or via H-rail • Visual scale for pressure adjustment • Certification: CCC 	<ul style="list-style-type: none"> • Pneumatic/electric differential pressure switch • Pneumatic/electric pressure transducer • Design for vacuum • Mounting on mounting frame 2N • Splash-proof design • Certification: CCC 	<ul style="list-style-type: none"> • Five pressure measuring ranges • Measurement of relative or differential pressure • Switching outputs PNP, NPN and with analogue current or voltage output • LCD or illuminated LCD display • Via H-rail, via wall/surface bracket, mounting on service unit, front panel mounting • Certification: c UL us Listed (OL), C-Tick
→ Page/online	pev	pen	762



Pressure and vacuum sensors

		
Type	Pressure sensor SDE3	Pressure sensor SDE5
Pressure measuring range	-1 ... 10 bar	-1 ... 10 bar
Switching element function	Switchable	N/O contact, switchable, N/C contact
Pneumatic connection	QS-5/32, QS-4	QS-5/32, QS-1/4, QS-4, QS-6
Electrical connection	4-pin, 5-pin, cable, cable with plug, M8x1, M12x1, plug, to EN 60947-5-2, round design	3-wire, 3-pin, cable, M8x1, plug, to EN 60947-5-2, round design
Display type	Illuminated LCD	
Description	<ul style="list-style-type: none"> • Five pressure measuring ranges • Measurement of relative or differential pressure or 2 independent pressure inputs • Switching output 2x PNP or 2x NPN • Numerical and graphical pressure indication • Via H-rail, via wall/surface bracket, front panel mounting, via through-holes • Certification: C-Tick, ATEX, c UL us Listed (OL) 	<ul style="list-style-type: none"> • Programmable and configurable pressure switch for simple pressure sensing tasks • Trigger/window comparator • Teach-in function for programming • Integrated microprocessor • Switching status indicated by an LED visible from all sides • Certification: c UL us Listed (OL), C-Tick
→ Page/online	sde3	767





Flow sensors

Type	 Flow sensor SFAB	 Flow sensor SFAM	 Flow sensor SFE3
Flow measuring range	0.1 ... 1,000 l/min	10 ... 15,000 l/min	0.05 ... 50 l/min
Operating medium	Compressed air to ISO 8573-1:2010 [6:4:4], compressed air to ISO 8573-1:2010 [7:4:4], nitrogen	Compressed air to ISO 8573-1:2010 [7:4:4], nitrogen	Compressed air to ISO 8573-1:2010 [1:4:2], nitrogen
Operating pressure	0 ... 10 bar	0 ... 16 bar	-0.7 ... 7 bar
Pneumatic connection	QS-5/16, QS-1/4, QS-3/8, QS-6, QS-8, QS-10, QS-12	Manifold module, G1/2, G1, G1 1/2, NPT1 1/2-11 1/2, NPT1-11 1/2, NPT1/2-14	Female thread G1/8, QS-6
Electrical connection	5-pin, M12x1, straight plug	5-pin, M12x1, straight plug	Cable
Description	<ul style="list-style-type: none"> Flow sensor with integrated digital display With unidirectional flow input Mounting: H-rail mounting, wall or surface mounting Certification: C-Tick 	<ul style="list-style-type: none"> Stand-alone device or combined with MS series service units Supplies absolute flow information and accumulated air consumption measurement Covers large measuring range with specified precision thanks to high dynamic response Large, illuminated LCD display 	<ul style="list-style-type: none"> Flow sensor with integrated digital display With unidirectional flow input Mounting: via through-holes or mounting bracket Electrical connection via open cable end Cable length 1 m Certification: C-Tick
→ Page/online	sfab	sfam	sfe3





Flow sensors

Type	 Flow sensor SFET	 Flow indicator SFEV
Flow measuring range	-10 ... 50 l/min	Cable
Operating medium	Compressed air to ISO 8573-1:2010 [1:4:2], nitrogen	
Operating pressure	-0.9 ... 7 bar	
Pneumatic connection	Female thread G1/8, QS-4, QS-6	
Electrical connection	Cable	
Description	<ul style="list-style-type: none"> With unidirectional (SFET-F) or bidirectional (SFET-R) flow input Mounting: via through-holes or mounting bracket Electrical connection via open cable end Cable length 1, 3 m Certification: C-Tick 	<ul style="list-style-type: none"> For flow sensor SFET 3 1/2-digit alphanumeric display Indicating range: 0.05 ... 50 l/min (for flow sensor SFET-F), -0.05 ... +10 l/min (for flow sensor SFET-R)
→ Page/online	sfet	sfev



Opto-electronic sensors

Type				
Method of measurement	Diffuse sensor, retro-reflective sensor, background suppression sensor, diffuse sensor with cylindrical light beam, distance sensor, for transparent objects, laser retro-reflective sensor	Through-beam sensor, receiver, transmitter	Fibre-optic unit	Contrast sensor, background suppression sensor, laser retro-reflective sensor
Working range	0 ... 5,500 mm	0 ... 20,000 mm	0 ... 250 mm	0 ... 20,000 mm
Size	Diameter 4 mm, M5, M12x1, M18x1 straight, M18x1 angled, 20x32x12 mm, 30x30x15 mm, 50x50x17 mm	M18x1 straight, M18x1 angled, 20x32x12 mm, 30x30x15 mm, 50x50x17 mm	20x32x12 mm, 30x30x15 mm	20x32x12 mm, 50x50x17 mm
Type of light	Infrared, red, polarised red	Infrared, red	Red	Laser, red, polarised red
Switching output	NPN, PNP	NPN, PNP	NPN, PNP	NPN, PNP
Description	<ul style="list-style-type: none"> Round design, block design Setting option: teach-in by means of a button and via electrical connection Electrical connection via open cable end or plug 	<ul style="list-style-type: none"> Round design, block design Setting option: potentiometer, teach-in or teach-in via electrical connection Electrical connection via open cable end or plug 	<ul style="list-style-type: none"> Block design Setting option: potentiometer, teach-in or teach-in via electrical connection Electrical connection via open cable end or plug 	<ul style="list-style-type: none"> Setting option: teach-in, teach-in via electrical connection, potentiometer Electrical connection via open cable end or plug
→ Page/online	771	771	771	771





Opto-electronic sensors

Type				
Method of measurement	Colour sensor	Fibre-optic unit	Fork light barrier	Through-beam sensor, fixed focus, fork light barrier, diffuse sensor
Working range	12 ... 32 mm	2 ... 2,000 mm		2 ... 650 mm
Size	50x50x17 mm		Fork 120x60 mm, fork 30x35 mm, fork 50x55 mm, fork 80x55 mm	
Type of light	White	Red	Red	
Switching output	PNP	NPN, PNP	NPN, PNP	
Description	<ul style="list-style-type: none"> Diffuse sensor Block design Setting option: teach-in, teach-in via electrical connection Electrical connection via plug M12x1, 8-pin Display via 7 LEDs 	<ul style="list-style-type: none"> Use for precise and space-saving position sensing in electronics and light assembly Switching frequencies up to 8,000 Hz Operational with fibre-optic cable SOOC as accessory Variants: LED or LED display, timer function Setting option: teach-in H-rail mounting or via through-holes With protection against mutual interference 	<ul style="list-style-type: none"> Through-beam sensor with minimal installation effort Design: polymer or metal Sturdy housing: high shock and vibration resistance Protection class IP67 Electrical connection via plug M8x1, 3-pin Setting option: potentiometer or teach-in LED displays 	<ul style="list-style-type: none"> Thread M4, M6 Voltage 10 ... 30 V DC Cable connection, push-in connector
→ Page/online	soec	soe4	soof	sooc



Signal converters

		
Type	Signal converter SVE4	Evaluation unit SMH-AE
Signal range	0 ... 10 V +/-0.3 V, 0 ... 20 mA +/-0.6 mA, adapted for position sensors SMH-S1-HG	
Switching output	2x NPN, 2x PNP	NPN, PNP
Switching function	Freely programmable	
Electrical connection, output	4-pin, M8x1, plug, to EN 60947-5-2	5-pin, plug, M12x1
Electrical connection, input	4-pin, socket, M8x1, to EN 60947-5-2	4-pin, socket, M8x1, to EN 60947-5-2
Description	<ul style="list-style-type: none"> • Converts analogue signals into switching points • Switching function freely programmable via teach-in • Threshold value, hysteresis or window comparator • Mounting directly on H-rail or via adapter plate • LED switching status indication • Certification: c UL us Listed (OL), C-Tick 	<ul style="list-style-type: none"> • Electronic evaluation unit for Hall sensor SMH-S1 • Amplifies the signal from the sensor • With 3 potentiometers for setting 3 switching points • LED operating and switching status indicators
→ Page/online	sve4	smh-ae

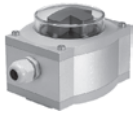

Air gap sensors

				
Type	Air gap sensor SOPA	Micro reflex sensor, reflex sensor RML, RFL	Back pressure end stop SD-2, SD-3, SD-3-N	Air barrier SFL, SML
Sensing range	20 ... 200 µm	Distance between nozzles 4.8 ... 5.1 mm, 4.5 ... 15.5 mm	Distance between nozzles 0 ... 0.5 mm	Distance between nozzles 5 ... 50 mm, to 100 mm
Operating pressure	4 ... 7 bar	0.075 ... 0.5 bar, 0.1 ... 1.5 bar	0 ... 8 bar	0.1 ... 0.4 bar, 0.1 ... 4 bar, 0 ... 8 bar
Display type	Illuminated LCD, multi-colour	Signal pressure ≥0.5 mbar	Pressure signal 0 ... 8 bar	Pneumatic signal
Operating medium	Compressed air to ISO 8573--1:2010 [7:4:4]	Filtered, unlubricated compressed air	Compressed air, filtered, lubricated or unlubricated	Filtered, unlubricated compressed air
Description	<ul style="list-style-type: none"> • Convenient solution for high-precision contact and distance monitoring • Setting option: teach-in or numerical setting using three buttons • Integrated air jet function • Multi-coloured LCD display • H-rail mounting, wall mounting, via through-holes • Certification: C-Tick 	<ul style="list-style-type: none"> • Back pressure actuated valve • For non-contacting sensing of indicating instruments, checking pressing and stamping tools, edge control, magazine control, for measuring and counting • Can be used with heavy accumulations of dirt, in complete darkness, with translucent or magnetic objects 	<ul style="list-style-type: none"> • Can be used for stroke-dependent signal generation as a limit switch and fixed stop • Type SD-3-N for sensing of fluid levels and heavily foaming liquids • Ideal for end-position sensing and position control with high accuracy requirements and small actuating forces • For use in inaccessible places 	<ul style="list-style-type: none"> • Sender nozzle, receiver nozzle, gap sensor • Back pressure actuated valve • Operational reliability even with heavy accumulation of dirt • Reliable even with high ambient temperatures • Insensitive to mechanical influences and sound waves • Reliable even in complete darkness and when sensing translucent objects
→ Page/online	sopa	rfl	sd	sml



Sensor boxes

			
Type	Sensor box SRAP	Sensor box SRBP	Limit switch attachment SRBF
Measured variable	Rotation angle	Rotation angle	
Operating voltage range AC		19.2 ... 28.8 V	0 ... 250 V
Operating voltage range DC	15 ... 30 V	7.8 ... 28.8 V	0 ... 24 V
Electrical connection	9-pin, screw terminal, plug-in	9-pin, screw terminal, plug-in	
Type of mounting	Adapter kit DASB, coupling DARQ	Adapter kit DASB, coupling DARQ	On flange to ISO 5211, via accessories
Description	<ul style="list-style-type: none"> Based on VDI/VDE 3845 (NAMUR) Analogue For monitoring the position of semi-rotary actuators Sensors based on 2D Hall technology 	<ul style="list-style-type: none"> Based on VDI/VDE 3845 (NAMUR) Binary Position sensor for semi-rotary actuators Sensors based on reed technology 	<ul style="list-style-type: none"> Based on ISO 5211, DIN EN 60947-5-1 With two mechanical switches For mechanical, electric proximity sensor
→ Page/online	srap	srbp	srbf

Sensor boxes

		
Type	Limit switch attachment DAPZ	Limit switch attachment QH-DR-E
Measured variable		
Operating voltage range AC	0 ... 250 V	0 ... 250 V
Operating voltage range DC	0 ... 250 V	0 ... 250 V
Electrical connection	Screw terminal, plug-in	Screw terminal
Type of mounting	Kit DAPZ-...RO	Via through-holes
Description	<ul style="list-style-type: none"> Square or round design Drive interface to NAMUR VDI/VDE 3845 With pneumatic, electric or inductive sensing 	<ul style="list-style-type: none"> Three measuring principles: pneumatic; mechanical, electrical; inductive
→ Page/online	dapz	qh-dr

Electromechanical switches

		
Type	Micro switch S-3	Electric limit switch EL, ER
Operating voltage range AC	12 ... 250 V	0... 250 V
Operating voltage range DC	12 ... 250 V	0 ... 250 V
Electrical connection	Screw connector	4-wire cable with protective earth conductor, 1.1 m
Protection class	IP00	IP54
Type of mounting	2 through-holes in housing, mounting plate	2 through-holes in housing
Description	<ul style="list-style-type: none"> Electrical limit switch N/C contact, N/O contact, changeover switch Actuator attachments: roller lever type AR, roller lever with idle return type AL, whisker attachment type AF 	<ul style="list-style-type: none"> For signalling in end positions Max. switching frequency 200/min With roller lever or with toggle lever and idle return N/C contact, N/O contact, changeover switch
→ Page/online	s-3	el

Proximity sensors SME/SMT-8, for T-slot

FESTO



- Switching output via reed contact or non-contacting
 - Secured with screw or clamped, insertable in the slot from above or lengthwise
 - Heat, welding field and corrosion-resistant designs
 - Suitable for use with energy chains and robots
 - Selected types in accordance with the ATEX Directive for explosive atmospheres → www.festo.com/catalogue/ex
- ★ Quick ordering of basic designs → 733, 736, 740

→ www.festo.com/catalogue/sm

Product range overview

Measuring principle	Type	Electrical connection	Operating voltage range	Switching output	Switching element function	→ Page/online
Magnetic reed	Standard					
	SME-8M	Cable – 2-wire – 3-wire Cable with plug, 2-pin Cable with plug, 3-pin – M8x1, rotatable thread – M8x1, snap-on flange – M12x1, rotatable thread	5 ... 30 V AC 5 ... 30 V DC	Contacting, bipolar	N/O contact N/C contact	732
	SME-8	Cable – 2-wire – 3-wire Cable with plug, 3-pin – M8x1	3 ... 230 V AC 3 ... 230 V DC	Contacting, bipolar	N/O contact N/C contact	734
	SME-8-SL	Plug, 3-pin – M8x1	10 ... 30 V AC 10 ... 30 V DC	Contacting, bipolar	N/O contact	sme
	SME-8-FM	Cable – 2-wire – 3-wire	10 ... 30 V AC 10 ... 30 V DC	Contacting, bipolar	N/O contact	sme
	Block design					
	SME0-8E	Plug, 3-pin – M8x1 – M12x1	3 ... 230 V AC 3 ... 250 V DC	Contacting, bipolar	N/O contact	smeo
	Heat-resistant up to 120 °C					
	SME-8-...-S6	Cable – 2-wire	0 ... 30 V AC 0 ... 30 V DC	Contacting, bipolar	N/O contact	734
	SME0-8E-...-S6	Cable – 2-wire	0 ... 30 V AC 0 ... 30 V DC	Contacting	N/O contact	smeo

Product range overview

Measuring principle	Type	Electrical connection	Operating voltage range	Switching output	Switching element function	→ Page/online
Magneto-resistive	Short design					
	SMT-8M-A	Cable, 3-wire Cable with plug, 3-pin – M8x1, rotatable thread – M12x1, rotatable thread	5 ... 30 V DC	PNP	N/O contact	737
				NPN Non-contacting, 2-wire	N/C contact	
	Standard					
	SMT-8	Cable, 3-wire Cable with plug, 3-wire – M8x1	10 ... 30 V DC	PNP NPN	N/O contact	smt
	SMT-8-SL	Plug, 3-pin – M8x1	10 ... 30 V DC	PNP	N/O contact	smt
	SMT-8G	Cable, 3-wire Cable with plug, rotatable thread – M8x1, 3-pin	10 ... 30 V DC	PNP	N/O contact	smt
	Corrosion-resistant					
	CRSMT-8	Cable, 3-wire	10 ... 30 V DC	PNP	N/O contact	crsmt
	Block design					
SMT0-8E	Plug, 3-pin – M8x1 – M12x1	10 ... 30 V DC	PNP NPN	N/O contact	smt0	
Magneto-inductive	Welding field immune					
	SMTSO-8E	Plug, 3-pin – M12x1	10 ... 30 V DC	PNP NPN	N/O contact	smtso

Proximity sensors SME-8M, for T-slot

Technical data

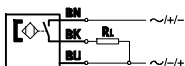

E.g. N/O contact, 3-wire, with cable

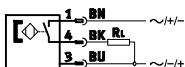

E.g. N/O contact, 3-wire, with plug



Technical data		Download CAD data → www.festo.com		
SME-8M-		DS	ZS	D0
Measuring principle	Magnetic reed			
Switching output	Contacting, bipolar			
Switching element function	N/O contact		N/O contact	N/C contact
Operating voltage range	[V DC]	5 ... 30		
Operating voltage range	[V AC]	5 ... 30		
Max. output current	[mA]	500	80	80
Type of mounting	Secured with screw, insertable in the slot from above			
Cable length	[m]	0.2 ... 10		
Max. connecting cable length	[m]	10		
Length/width/height	[mm]	32/5/5		

Pin allocation to EN 60947-5-2

DS			
Plug, 3-pin			
M12x1	Pin	Wire colour	Allocation
	1	Brown	+
	3	Blue	-
	4	Black	Output

DS			
Plug, 3-pin			
M8x1	Pin	Wire colour	Allocation
	1	Brown	+
	3	Blue	-
	4	Black	Output

ZS			
Plug, 2-pin			
M8x1	Pin	Wire colour	Allocation
	1	Brown	+
	4	Blue	-

ZS			
Plug, 2-pin			
M12x1	Pin	Wire colour	Allocation
	1	Brown	+
	4	Blue	-

D0			
Plug, 3-pin			
M8x1	Pin	Wire colour	Allocation
	1	Brown	+
	3	Blue	-
	4	Black	Output

D0			
Plug, 3-pin			
M12x1	Pin	Wire colour	Allocation
	1	Brown	+
	3	Blue	-
	2	White	Output

Operating conditions

Ambient temperature	[°C]	-40 ... +70
Ambient temperature with flexible cable installation	[°C]	-5 ... +70

Materials

Housing	PA, TPE-(PU), high-alloy stainless steel, nickel-plated brass
Cable sheath	TPE-U (PU), oil-resistant

Order code

		SME	-	8M	-		-	24V	-		-		-	
Type														
SME	Proximity sensor, magnetic reed													
Design														
8M	For T-slot, insertable in the slot from above													
Switching output, switching element function														
DS	N/O contact, 3-wire													
ZS	N/O contact, 2-wire													
DO	N/C contact, 3-wire													
Rated operating voltage														
24V	24 V DC													
Cable characteristics														
K	Standard + energy chain													
E	Energy chain + robot													
Cable length [m]														
...	0.2 m ... 10 m (0.2 ... 5.0 m in 0.1 m increments, 5.0 ... 10 m in 0.5 m increments)													
Connection technology														
OE	Open end													
M8	Cable with plug M8x1, snap-on flange													
M8D	Cable with plug M8x1, rotatable thread													
M12	Cable with plug M12x1, rotatable thread													

Ordering – Product options



Configurable product

This product and all its options can be ordered using the configurator.

The configurator can be found under Products on the DVD or
[→ www.festo.com/catalogue/...](http://www.festo.com/catalogue/...)

Enter the type code in the search field.

★ Quick ordering

N/O contact, contacting, bipolar

Part No.	Type
Cable, 3-wire	
543862	SME-8M-DS-24V-K-2,5-OE
543863	SME-8M-DS-24V-K-5,0-OE
Cable with plug, M8x1, rotatable thread, 3-pin	
543861	SME-8M-DS-24V-K-0,3-M8D
Cable, 2-wire	
543872	SME-8M-ZS-24V-K-2,5-OE

N/C contact, contacting, bipolar

Part No.	Type
Cable, 3-wire	
546799	SME-8M-DO-24V-K-7,5-OE

Proximity sensors SME-8, for T-slot

Technical data

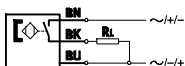

E.g. N/O contact, 3-wire, with cable

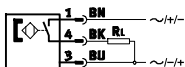

E.g. N/O contact, 3-wire, with plug



Technical data		Download CAD data → www.festo.com					
Electrical connection	3-wire			2-wire			
Connection direction	In-line			In-line			
Variant	Standard			Heat-resistant	Standard		
SME-8-	K	S	0	K-24-S6	K-LED-230	ZS	
Measuring principle	Magnetic reed						
Switching output	Contacting, bipolar				Without LED function		
Switching element function	N/O contact	N/O contact	N/C contact	N/O contact	N/O contact	N/O contact	
Operating voltage range [V DC]	12 ... 30	12 ... 30	12 ... 30	0 ... 30	3 ... 230	12 ... 27	
Operating voltage range [V AC]	12 ... 30	12 ... 30	12 ... 30	0 ... 30	3 ... 230	–	
Max. output current [mA]	500	500	50	500	120	80	
Type of mounting	Clamped in T-slot, insertable in the slot lengthwise						
Cable length [m]	2.5	0.3	7.5	2.5	2.5	2.5	
	5						
	7.5						
Length/width/height [mm]	29/7/5	29/7/5	31/7/5	29/7/5	27/7/10	31/7/5	

Pin allocation to EN 60947-5-2

Plug, 3-pin, M8x1	Pin	Wire colour	Allocation
	1	Brown	+
	3	Blue	–
	4	Black	Output

Operating conditions

Electrical connection	K	K5	K-7,5	S	0	K-24-S6	K-LED-230	ZS
Ambient temperature [°C]	–40 ... +60	–40 ... +70	–40 ... +70	–40 ... +70	–40 ... +60	–40 ... +120	–30 ... +60	–40 ... +60
Ambient temperature with flexible cable installation [°C]	–5 ... +60	–5 ... +70	–5 ... +70	–5 ... +70	–5 ... +60	–5 ... +120	–5 ... +60	–5 ... +60

Materials

SME-8	SME-8-...-S6
Housing	Epoxy resin, PC, PET, high-alloy stainless steel
Cable sheath	TPE-U (PUR) / Thermoplastic styrene elastomer

Order code – 3-wire

	SME	8		LED	24
Type					
SME	Proximity sensor, magnetic reed				
Design					
8	For T-slot, insertable in the slot lengthwise				
Switching element function					
–	N/O contact, 3-wire				
0	N/C contact, 3-wire				
Electrical connection, cable length					
K	Cable, 2.5 m (N/O contact) Cable, 7.5 m (N/C contact)				
K5	Cable, 5 m				¹
K-7,5	Cable, 7.5 m				¹
S	Cable with plug M8x1, 0.3 m				¹
Switching status display					
LED	Yellow LED				
Rated operating voltage					
24	24 V DC				

¹ Not with switching element function 0.

Order code – 2-wire, heat-resistant

	SME	8	K	24	S6
Type					
SME	Proximity sensor, magnetic reed				
Design					
8	For T-slot, insertable in the slot lengthwise				
Switching element function					
–	N/O contact, 2-wire				
Electrical connection, cable length					
K	Cable, 2.5 m				
Rated operating voltage					
24	24 V DC				
Variant					
S6	Heat-resistant				

Proximity sensors SME-8, for T-slot

Order code – 2-wire, in-line connection

		SME	–	8	–		–	LED	–	
Type										
SME	Proximity sensor, magnetic reed									
Design										
8	For T-slot, insertable in the slot lengthwise									
Switching element function										
–	N/O contact, 2-wire									
ZS	N/O contact, without LED function, 2-wire									
Electrical connection, cable length										
K	Cable, 2.5 m	1								
KL	Cable, 2.5 m	2								
Switching status display										
LED	Yellow LED									
Rated operating voltage										
24	24 V DC	2								
230	230 V AC	1								

- 1 Not with switching element function ZS
- 2 Only with switching element function ZS

Ordering – Product options

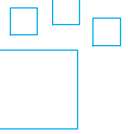

Configurable product

This product and all its options can be ordered using the configurator.

The configurator can be found under Products on the DVD or
www.festo.com/catalogue/...

Enter the type code in the search field.

★ Quick ordering

N/O contact, contacting, bipolar

Part No.	Type
Cable, 3-wire	
1 508 55	SME-8-K-LED-24

Technical data

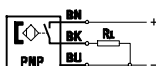

E.g. N/O contact, PNP, with cable

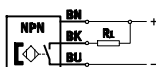

E.g. N/O contact, NPN, with cable

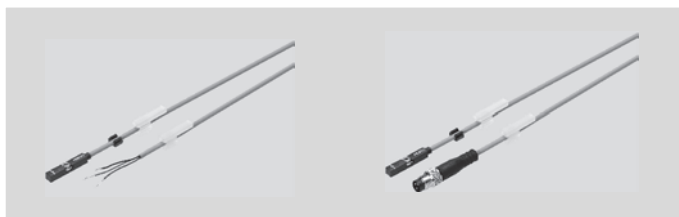

Technical data		Download CAD data → www.festo.com					
SMT-8M-A		PS	NS	PO	ZS	PNS	PSO
Measuring principle		Magneto-resistive					
Switching output		PNP	NPN	PNP	Non-contacting, 2-wire	PNP, NPN switchable	PNP
Switching element function		N/O contact	N/O contact	N/C contact	N/O contact	N/O contact	N/C contact, N/O contact switchable
Operating voltage range	[V DC]	5 ... 30				7 ... 30	
Max. output current	[mA]	100 ¹⁾	100 ¹⁾	100 ¹⁾	80 ¹⁾	100	100
Max. output current in mounting kits	[mA]	100			80 ¹⁾	100	
Max. switching capacity DC	[W]	2.8	2.8	2.8	1.9	2.7	2.7
Max. switching capacity DC in mounting kits	[W]	2.8 ²⁾	2.8 ²⁾	2.8 ²⁾	1.5 ²⁾	2.7	2.7
Type of mounting		Secured with screw, insertable in the slot from above					
Cable length	[m]	0.1 ... 30					
Max. connecting cable length	[m]	30					
Length/width/height	[mm]	29/5/5				35/5/5	

- 1) Variant ...-PS/NS/PO-...-Ex2: Max. output current in mounting kits 80 mA, T_a 70 °C
 Variant ...-ZS-...-Ex2: Max. output current in mounting kits 50 mA, T_a 70 °C
 2) Variant ...-PS/NS/PO-...-Ex2: Max. switching capacity 2.2 W
 Variant ...-ZS-...-Ex2: Max. switching capacity 1.2 W

Pin allocation to EN 60947-5-2

ZS			
M8x1, 2-pin			
M8x1	Pin	Wire colour	Allocation
	1	Brown	+
	4	Blue	-

ZS			
M12x1, 2-pin			
M12x1	Pin	Wire colour	Allocation
	1	Brown	+
	4	Blue	-

Pin allocation to EN 60947-5-2

PS/NS/PO			
Plug, 3-pin			
M8x1	Pin	Wire colour	Allocation
	1	Brown	+
	3	Blue	-
	4	Black	Output

PS/NS			
Plug, 3-pin			
M12x1	Pin	Wire colour	Allocation
	1	Brown	+
	3	Blue	-
	4	Black	Output

PO			
Plug, 3-pin			
M12x1	Pin	Wire colour	Allocation
	1	Brown	+
	3	Blue	-
	2	White	Output

Technical data

Operating conditions		
Ambient temperature	[°C]	-40 ... +85
Ambient temperature with flexible cable installation	[°C]	-20 ... +85

ATEX		
SMT-8M-A-...-		Ex2
ATEX category for gas		II 3G
Explosion ignition protection type for gas		Ex nA IIC T4 X Gc
ATEX category for dust		II 3D
Explosion ignition protection type for dust		Ex tc IIIC T120 °C X Dc IP65
Explosion-proof temperature		-40 °C ≤ Ta ≤ +70 °C
ATEX certification		For zones 2 and 22
CE marking (see declaration of conformity)		To EU Explosion Protection Directive (ATEX)

Materials		
Housing		PA reinforced, high-alloy stainless steel, nickel-plated brass
Cable sheath		TPE-U (PU)

Order code

		SMT-8M	-	A	-		-	24 V	-	E	-		-		-		-	
Type																		
SMT-8M	Proximity sensor, magneto-resistive, for T-slot, insertable in the slot from above																	
Design																		
A	Short design																	
Switching output																		
PS	PNP, N/O contact, 3-wire																	
PO	PNP, N/C contact, 3-wire																	
NS	NPN, N/O contact, 3-wire																	
ZS	N/O contact, 2-wire																	
PNS	PNP, NPN switchable																	
PSO	PNP, N/C contact, N/O contact switchable																	
Rated operating voltage																		
24 V	24 V DC																	
Cable characteristics																		
E	Energy chain + robot																	
Cable length (m)																		
...	0.1 m ... 30 m (0.1 ... 5.0 m in 0.1 m increments, 5.0 ... 30 m in 0.5 m increments)																	
Cable designation																		
-	With inscription label holder																	
N	Without inscription label holder																	
Electrical connection																		
OE	Open end																	
M8	Cable with plug M8x1, snap-on flange																	
M8D	Cable with plug M8x1, rotatable thread																	
M12	Cable with plug M12x1, rotatable thread																	
EU certification																		
Ex2	II 3GD in accordance with 1 EU Directive 94/9/EC																	

1 Not with switching output PNS, PSO, minimum cable length 0.2 m.

Ordering – Product options

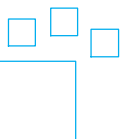

Configurable product

This product and all its options can be ordered using the configurator.

The configurator can be found under Products on the DVD or
[→ www.festo.com/catalogue/...](http://www.festo.com/catalogue/...)

Enter the type code in the search field.

Proximity sensors SMT-8M-A, for T-slot

FESTO

★ Quick ordering

Switching output	Electrical connection			Cable length [m]	Part No.	Type
	Cable	Cable with plug, rotatable thread				
		M8x1	M12x1			
N/O contact						
PNP	–	3-pin	–	0.3	574334	SMT-8M-A-PS-24V-E-0,3-M8D
PNP	3-wire	–	–	2.5	574335	SMT-8M-A-PS-24V-E-2,5-OE
PNP	3-wire	–	–	5	574336	SMT-8M-A-PS-24V-E-5,0-OE
PNP	–	–	3-pin	0.3	574337	SMT-8M-A-PS-24V-E-0,3-M12
NPN	3-wire	–	–	2.5	574338	SMT-8M-A-NS-24V-E-2,5-OE
PNP	–	–	3-pin	0.3	574339	SMT-8M-A-NS-24V-E-0,3-M8D
PNP	3-wire	–	–	7.5	574340	SMT-8M-A-PO-24V-E-7,5-OE
Non-contacting	2-wire	–	–	5	574341	SMT-8M-A-ZS-24V-E-5,0-OE-Ex2

Accessories

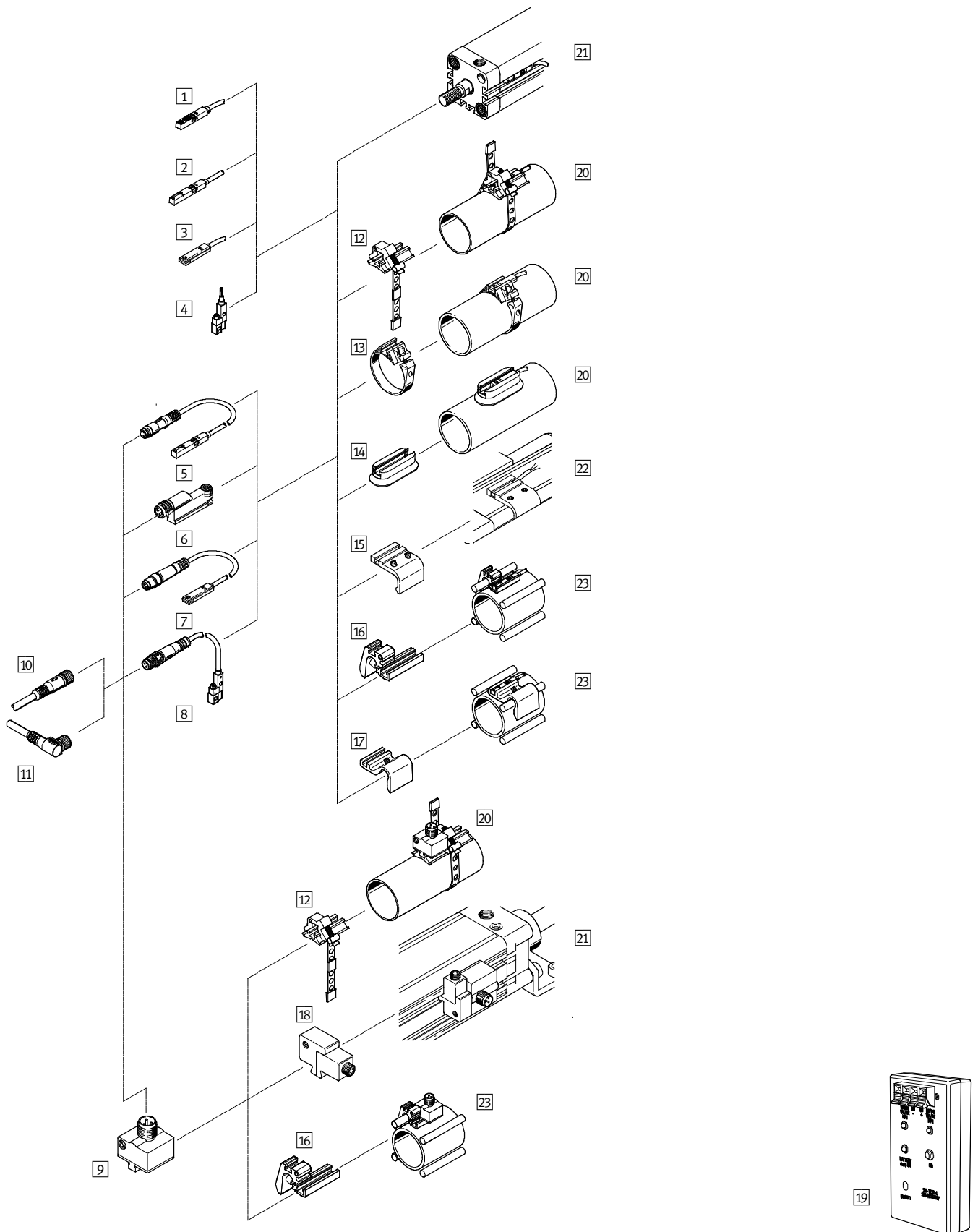





Proximity sensors SME/SMT-8, for T-slot



Accessories





Mounting components and accessories		→ Page/ online
Proximity sensor		
1	SMT-8M-A..., with cable	737
2	SME-8M-...-OE, with cable	732
3	SME-8-...-K, with cable	732
	CRSMT-8-...-K, with cable, corrosion-resistant	crsmt
4	SMT-8G-...-OE, with cable	smt
5	SME-8M-...-M..., with cable with plug	732
6	SME-8-SL, with plug	sme
	SMT-8-SL, with plug	smt
7	SME-8-...-S, with cable with plug	732
8	SMT-8G-...-M..., with cable with plug	smt
9	SMEO-8E, with plug, block design	smeo
	SMTO-8E, with plug, block design	smtso
	SMTSO-8E, with plug, welding field immune	smtso
Accessories		
10	Connecting cable NEBU-M...G...	743
11	Connecting cable NEBU-M...W...	743



Mounting components and accessories		→ Page/ online
12	Mounting kit SMBR-8-8/100-S6, heat-resistant	743
13	Mounting kit SMBR	743
14	Mounting kit CRSMB, corrosion-resistant	743
15	Mounting kit SMB-8-FENG	743
16	Mounting kit SMBZ-8	743
17	Sensor bracket DASP-M4-... for DSBG-125	743
18	Mounting kit SMB-8E	743
19	Sensor tester SM-TEST-1	sm-test-1
-	Position marker SMM-8	743
	Inscription label ASLR	743
	Safety clip NEAU	neau
	Clip SMBK-8	743
Drives		
20	Round cylinders	-
21	Drives with T-slot	-
22	Standard cylinders DNC, DNCKE	
23	Drives with tie or mounting rod	

Accessories – Ordering data

	Cable length [m]		Part No.	Type
Connecting cable				
10 / 11 M8x1 Technical data → 949				
	2.5	★	541333	NEBU-M8G3-K-2.5-LE3
	5	★	541334	NEBU-M8G3-K-5-LE3
	2.5	★	541338	NEBU-M8W3-K-2.5-LE3
	5	★	541341	NEBU-M8W3-K-5-LE3
10 / 11 M12x1 Technical data → 949				
	2.5		541363	NEBU-M12G5-K-2.5-LE3
	5		541364	NEBU-M12G5-K-5-LE3
	2.5		541367	NEBU-M12W5-K-2.5-LE3
	5		541370	NEBU-M12W5-K-5-LE3

	For Ø		Part No.	Type
12 Mounting kit				
	8 ... 100	★	538937	SMBR-8-8/100-S6
	8	★	175091	SMBR-8-8
	10	★	175092	SMBR-8-10
	12	★	175093	SMBR-8-12
	16	★	175094	SMBR-8-16
	20	★	175095	SMBR-8-20
	25	★	175096	SMBR-8-25
	32	★	175097	SMBR-8-32
	40	★	175098	SMBR-8-40
	50	★	175099	SMBR-8-50
	63	★	175100	SMBR-8-63

	For Ø	Part No.	Type
13 ... 16 Mounting kit			
	32 ... 100	525565	CRSMB-8-32/100
	32/40	175705	SMB-8-FENG-32/40
	50/63	175706	SMB-8-FENG-50/63
	80/100	175707	SMB-8-FENG-80/100
	32 ... 100	537806	SMBZ-8-32/100
	125 ... 320	537808	SMBZ-8-125/320
	125	1451483	DASP-M4-125-A
	–	178230	SMB-8E

	Size	Part No.	Type	PU ¹⁾
Position marker				
	10	547941	SMM-8	10
Inscription label				
	23x4 mm	541598	ASLR-L-423	34
Clip				
	–	534254	SMBK-8	1

1) Packaging unit

Proximity sensors SME/SMT-10, for C-slot

FESTO



- Switching output via reed contact or non-contacting
 - Secured with screw or clamped, insertable in the slot from above or lengthwise
 - Suitable for use with energy chains and robots
 - Selected types in accordance with the ATEX Directive for explosive atmospheres → www.festo.com/catalogue/ex
- ★ Quick ordering of basic designs → 746, 751

→ www.festo.com/catalogue/sme-10

Product range overview

Measuring principle	Type	Electrical connection	Operating voltage range	Switching output	Switching element function	→ Page/online
Magnetic reed	SME-10M	Cable <ul style="list-style-type: none"> – 2-wire – 3-wire Cable with plug, 2-pin Cable with plug, 3-pin <ul style="list-style-type: none"> – M8x1, rotatable thread – M8x1, snap-on flange – M12x1, rotatable thread 	5 ... 30 V AC 5 ... 30 V DC	Contacting, bipolar	N/O contact	745
	SME-10	Cable <ul style="list-style-type: none"> – 3-wire Cable with plug, 3-pin <ul style="list-style-type: none"> – M8x1 	12 ... 27 V AC 12 ... 27 V DC	Contacting, bipolar	N/O contact	747
Magneto-resistive	SMT-10M	Cable <ul style="list-style-type: none"> – 2-wire – 3-wire Cable with plug, 2-pin Cable with plug, 3-pin <ul style="list-style-type: none"> – M8x1, rotatable thread – M8x1, snap-on flange – M12x1, rotatable thread 	10 ... 30 V DC	PNP NPN Non-contacting, 2-wire	N/O contact	749
	SMT-10G	Cable <ul style="list-style-type: none"> – 3-wire Cable with plug, 3-pin <ul style="list-style-type: none"> – M8x1, rotatable thread 	10 ... 30 V DC	PNP	N/O contact	smt-10

Technical data

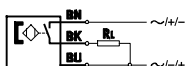

E.g. N/O contact, 3-wire, with cable

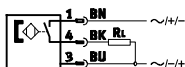

E.g. N/O contact, 3-wire, with plug



Technical data		DS		ZS		Download CAD data → www.festo.com
SME-10M-						
Measuring principle		Magnetic reed				
Switching output		Contacting, bipolar				
Switching element function		N/O contact				
Operating voltage range	[V DC]	5 ... 30				
Operating voltage range	[V AC]	5 ... 30				
Max. output current	[mA]	300		100		
Type of mounting		Secured with screw, insertable in the slot from above				
Connection direction		In-line				
		Lateral				
Cable length	[m]	0.2 ... 10				
Max. connecting cable length	[m]	10				
Length/width/height	[mm]	27/3/5 (25/3/6) ¹⁾				

1) Value in brackets for lateral connection.

Pin allocation to EN 60947-5-2

M8x1

2-pin	Pin	Wire colour	Allocation	3-pin	Pin	Wire colour	Allocation
	1	Brown	+		1	Brown	+
	4	Black	Output		3	Blue	-
					4	Black	Output

M12x1

2-pin	Pin	Wire colour	Allocation	3-pin	Pin	Wire colour	Allocation
	1	Brown	+		1	Brown	+
	4	Black	Output		3	Blue	-
					4	Black	Output

Operating conditions

Ambient temperature	[°C]	-40 ... +70
Ambient temperature with flexible cable installation	[°C]	-20 ... +70

Materials

Housing	PA reinforced, high-alloy stainless steel
Cable sheath	TPE-U (PUR)

Ordering – Product options

Configurable product

This product and all its options can be ordered using the configurator.

The configurator can be found under Products on the DVD or
→ www.festo.com/catalogue/...

Enter the type code in the search field.

Proximity sensors SME-10M, for C-slot

Order code

		SME	-	10M	-		-	24V	-	E	-		-		-		-	
Type																		
SME	Proximity sensor, magnetic reed																	
Design																		
10M	For C-slot, insertable in the slot from above																	
Switching output, switching element function																		
DS	N/O contact, 3-wire																	
ZS	N/O contact, 2-wire																	
Rated operating voltage																		
24V	24 V DC																	
Cable characteristics																		
E	Energy chain + robot																	
Cable length																		
...	0.2 m ... 10 m (0.2 ... 5.0 m in 0.1 m increments, 5.0 ... 10 m in 0.5 m increments)																	
Connection direction																		
L	In-line																	
Q	Lateral																	
Cable designation																		
-	With inscription label holder																	
N	Without inscription label holder																	
Connection technology																		
OE	Open end																	
M8	Cable with plug M8x1, snap-on flange																	
M8D	Cable with plug M8x1, rotatable thread																	
M12	Cable with plug M12x1, rotatable thread																	

★ Quick ordering

N/O contact, contacting, bipolar

Part No.	Type
Cable, 3-wire	
551365	SME-10M-DS-24V-E-2,5-L-OE
551366	SME-10M-DS-24V-E-2,5-Q-OE
Cable, 2-wire with plug, rotatable thread	
551367	SME-10M-DS-24V-E-0,3-L-M8D
551368	SME-10M-DS-24V-E-0,3-Q-M8D

Part No.	Type
Cable, 2-wire	
551369	SME-10M-ZS-24V-E-2,5-L-OE
551370	SME-10M-ZS-24V-E-2,5-Q-OE

Technical data

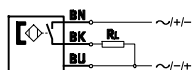

E.g. N/O contact, 3-wire, with cable

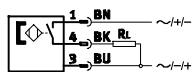

E.g. N/O contact, 3-wire, with plug



Technical data		Download CAD data → www.festo.com	
SME-10-...-		K	S
Measuring principle	Magnetic reed		
Switching output	Contacting, bipolar		
Switching element function	N/O contact		
Operating voltage range	[V DC]	12 ... 27	
Operating voltage range	[V AC]	12 ... 27	
Max. output current	[mA]	100	
Type of mounting	Clamped in C-slot, insertable in the slot lengthwise		
Connection direction	In-line		
	Lateral		
Cable length	[m]	2.5	0.3
Length/width/height	[mm]	22/4/6 (19/6/9) ¹⁾	

1) Value in brackets for lateral connection.

Pin allocation to EN 60947-5-2

Plug, 3-pin			
M8x1	Pin	Wire colour	Allocation
	1	Brown	+
	3	Blue	-
	4	Black	Output

Operating conditions

Ambient temperature	[°C]	-20 ... +70
Ambient temperature with flexible cable installation	[°C]	-5 ... +70

Materials

Housing	PPS, high-alloy stainless steel, TPE-U (PUR)
Cable sheath	TPE-U (PUR)

Proximity sensors SME-10, for C-slot

Order code

		SME	–	10	–		–	LED	–	24
Type										
SME	Proximity sensor, magnetic reed									
Design										
10	For C-slot, insertable in the slot lengthwise									
Electrical connection, cable length, connection direction										
KL	Cable, 2.5 m, in-line									
KQ	Cable, 2.5 m, lateral									
SL	Cable with plug M8x1, 0.3 m, in-line									
SQ	Cable with plug M8x1, 0.3 m, lateral									
Switching status display										
LED	Yellow LED									
Rated operating voltage										
24	24 V DC									

Ordering – Product options

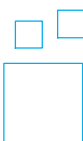

Configurable product

This product and all its options can be ordered using the configurator.

The configurator can be found under Products on the DVD or
[→ www.festo.com/catalogue/...](http://www.festo.com/catalogue/...)

Enter the type code in the search field.

10

★ Quick ordering

N/O contact, contacting, bipolar

Part No.	Type
Cable, 3-wire, lateral	
173211	SME-10-KQ-LED-24
173213	SME-10-SQ-LED-24

Technical data

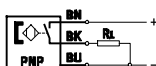

E.g. PNP, N/O contact, with cable

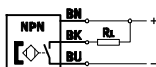

E.g. NPN, N/O contact, with cable



Technical data		Download CAD data → www.festo.com		
SMT-10M-	PS	NS	ZS	
Measuring principle	Magneto-resistive			
Switching output	PNP	NPN	Non-contacting, 2-wire	
Switching element function	N/O contact			
Operating voltage range [V DC]	10 ... 30			
Max. output current [mA]	100			
Type of mounting	Secured with screw, insertable in the slot from above			
Connection direction	In-line			
	Lateral			
Cable length [m]	0.2 ... 30			
Max. connecting cable length [m]	30			
Length/width/height [mm]	23/3/5 (21/3/6) ¹⁾			

1) Value in brackets for lateral connection.

Pin allocation to EN 60947-5-2

M8x1

2-pin	Pin	Wire colour	Allocation	3-pin	Pin	Wire colour	Allocation
	1	Brown	+		1	Brown	+
	4	Black	Output		3	Blue	-
					4	Black	Output

M12x1

2-pin	Pin	Wire colour	Allocation	3-pin	Pin	Wire colour	Allocation
	1	Brown	+		1	Brown	+
	4	Black	Output		3	Blue	-
					4	Black	Output

Operating conditions

Ambient temperature [°C]	-20 ... +70
Ambient temperature with flexible cable installation [°C]	-20 ... +70

Materials

Housing	PA, high-alloy stainless steel
Cable sheath	TPE-U (PU)

Proximity sensors SMT-10M, for C-slot

Order code

		SMT	-	10M	-		-	24V	-	E	-		-		-		-	
Type																		
SMT	Proximity sensor, magneto-resistive																	
Design																		
10M	For C-slot, insertable in the slot from above																	
Switching output, switching element function																		
PS	PNP, N/O contact, 3-wire																	
NS	NPN, N/O contact, 3-wire																	
ZS	N/O contact, 2-wire																	
Rated operating voltage																		
24V	24 V DC																	
Cable characteristics																		
E	Energy chain + robot																	
Cable length																		
...	0.2 m ... 30 m (0.2 ... 5.0 m in 0.1 m increments, 5.0 ... 30 m in 0.5 m increments)																	
Connection direction																		
L	In-line																	
Q	Lateral																	
Cable designation																		
-	With inscription label holder																	
N	Without inscription label holder																	
Connection technology																		
OE	Open end																	
M8	Cable with plug M8x1, snap-on flange																	
M8D	Cable with plug M8x1, rotatable thread																	
M12	Cable with plug M12x1, rotatable thread																	

Ordering – Product options

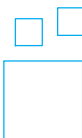

Configurable product

This product and all its options can be ordered using the configurator.

The configurator can be found under Products on the DVD or
[→ www.festo.com/catalogue/...](http://www.festo.com/catalogue/...)

Enter the type code in the search field.

★ Quick ordering

N/O contact

Part No.	Type
Cable, 3-wire, PNP	
551373	SMT-10M-PS-24V-E-2,5-L-OE
551374	SMT-10M-PS-24V-E-2,5-Q-OE
Cable with plug, M8x1, rotatable thread, 3-pin, PNP	
551375	SMT-10M-PS-24V-E-0,3-L-M8D
551376	SMT-10M-PS-24V-E-0,3-Q-M8D
Cable, 3-wire, NPN	
551377	SMT-10M-NS-24V-E-2,5-L-OE
551378	SMT-10M-NS-24V-E-2,5-Q-OE
Cable with plug, M8x1, rotatable thread, 3-pin, NPN	
551379	SMT-10M-NS-24V-E-0,3-L-M8D
551380	SMT-10M-NS-24V-E-0,3-Q-M8D

Part No.	Type
Cable, 2-wire, non-contacting	
551382	SMT-10M-ZS-24V-E-2,5-L-OE
551383	SMT-10M-ZS-24V-E-2,5-Q-OE

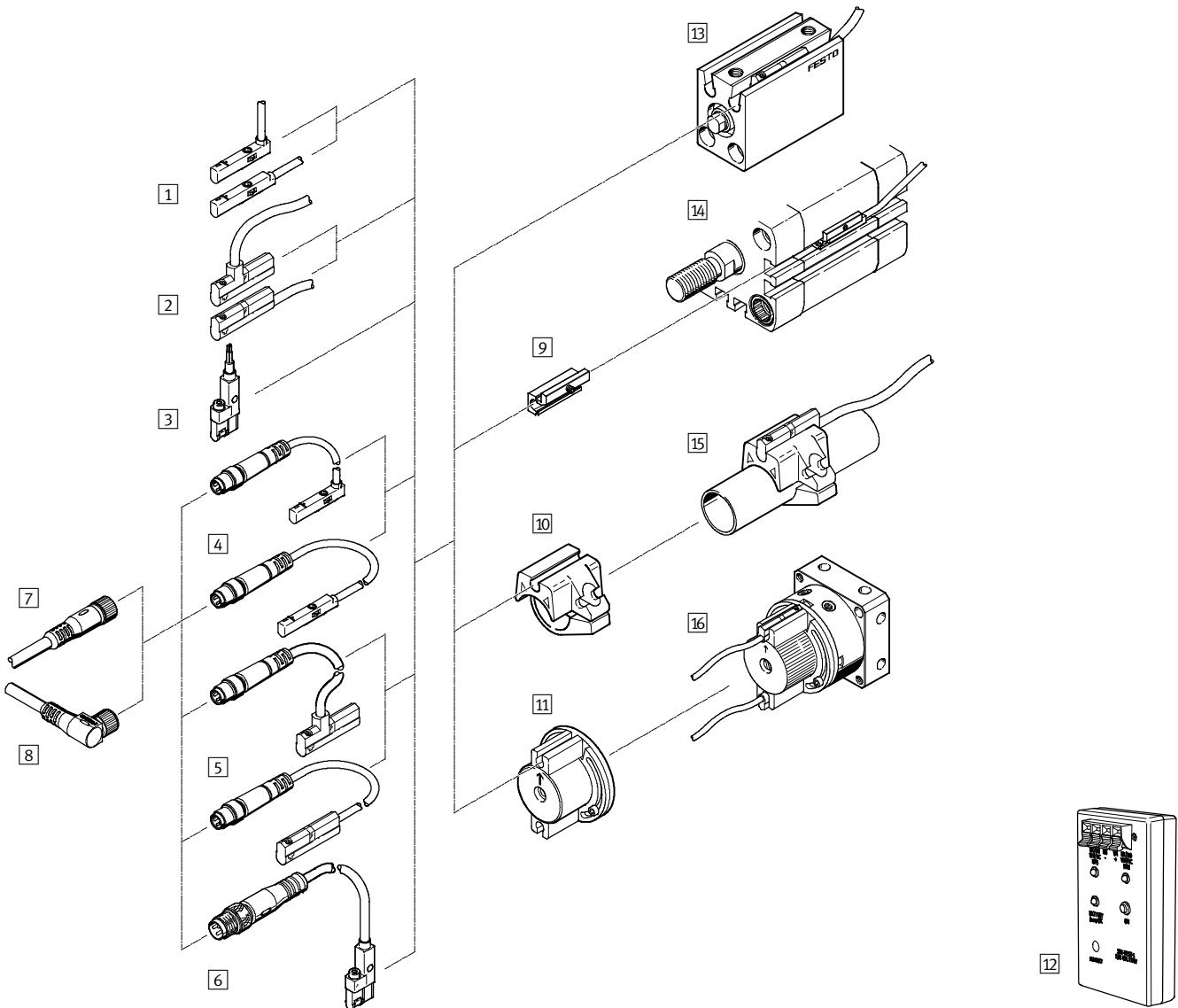

Accessories





Mounting components and accessories		→ Page/ online
Proximity sensor		
1	SME-10M-...-OE, with cable SMT-10M-...-OE, with cable	745 749
2	SME-10-...-K, with cable	747
3	SMT-10G-...-OE, with cable	smt-10
4	SME-10M-...-M..., with cable with plug SMT-10M-...-M..., with cable with plug	745 749
5	SME-10-...-S..., with cable with plug	747
6	SMT-10G-...-M..., with cable with plug	smt-10

Mounting components and accessories		→ Page/ online
Accessories		
7	Connecting cable NEBU-M8G3	753
8	Connecting cable NEBU-M8W3	753
9	Mounting SMBN-10	753
10	Mounting kit SMBR-10	753
11	Mounting kit WSM-...-SME-10	753
12	Sensor tester SM-TEST-1	sm-test-1
-	Position marker SMM-10	753
-	Inscription label ASLR	753
-	Safety clip NEAU	neau
-	Clip SMBK-8	smbk
Drives		
13	Drives with C-slot	-
14	Drives with T-slot	
15	Round cylinders	
16	Swivel module DSM	



Accessories – Ordering data

	Cable length [m]		Part No.	Type
7 Connecting cable, straight plug M8x1 Technical data → 949				
	2.5	★	541333	NEBU-M8G3-K-2.5-LE3
	5	★	541334	NEBU-M8G3-K-5-LE3
8 Connecting cable, angled socket M8x1				
	2.5	★	541338	NEBU-M8W3-K-2.5-LE3
	5	★	541341	NEBU-M8W3-K-5-LE3

	For Ø		Part No.	Type
9 Mounting				
	125 ... 320		537809	SMBN-10

10 Mounting kit for round cylinder				
	8		175101	SMBR-10-8
	10		173227	SMBR-10-10
	12		175102	SMBR-10-12
	16		173228	SMBR-10-16
	20		175103	SMBR-10-20
	25		175104	SMBR-10-25
	32		175105	SMBR-10-32
	40		175106	SMBR-10-40
	50		175107	SMBR-10-50
63		175108	SMBR-10-63	

11 Mounting kit for swivel module				
	6		173205	WSM-6-SME-10
	8		173206	WSM-8-SME-10
	10		173207	WSM-10-SME-10

	Size		Part No.	Type	PU ¹⁾
Position marker					
	10		547942	SMM-10	10
Inscription label					
	23x4 mm		541598	ASLR-L-423	34

1) Packaging unit



- Versions for DC and AC voltage
- Switching output PNP, NPN or analogue output
- Corrosion-resistant and welding field immune versions
- Versions with increased switching distance
- ★ Quick ordering of basic designs → 757

→ www.festo.com/catalogue/sie

Product range overview

Version	Type	Operating voltage	Switching output/ analogue output	Mounting	Size	→ Page/ online
Reduction factor, material-specific						
Standard switching distance	SIEN Basic design	10 ... 30 V DC 15 ... 34 V DC	PNP NPN	Flush Non-flush	∅ 4 mm, M5, ∅ 6.5 mm, M8, M12, M18, M30	755
	SIEN-...-PA Polyamide housing	10 ... 30 V DC	PNP NPN	Flush Non-flush	M12, M18, M30	756
	SIED Basic design	20 ... 265 V AC 20 ... 320 V DC	Non-contacting, 2-wire	Flush Non-flush	M12, M18, M30	sied
	SIED-...-PA Polyamide housing	20 ... 250 V AC 10 ... 300 V DC	Non-contacting, 2-wire	Flush Non-flush	M12, M18, M30	sied
	SIES Special design	10 ... 30 V DC	PNP NPN	Flush	5x5x25 mm ... 40x40x120 mm	sies
	Increased switching distance	SIEH Basic design	10 ... 30 V DC 15 ... 34 V DC	PNP NPN	Flush	∅ 3 mm, M12, M18
SIEH-...-CR Stainless steel housing		10 ... 30 V DC	PNP NPN	Flush	M12, M18	sieh
Analogue output	SIEA	15 ... 30 V DC	0 ... 10 V and 4 ... 20 mA	Flush	M8, M12, M18, M30	siea
Reduction factor 1 for all metals, welding field immune						
Increased switching distance	SIEF Basic design	10 ... 65 V DC	PNP NPN	Flush Partially flush	M8, M12, M18, M30, 40x40x65 mm	sief
	SIEF-...-WA Housing resistant to welding spatter	10 ... 30 V DC	PNP NPN	Flush Partially flush	M12, M18, M30	sief

Technical data – With standard switching distance

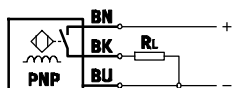

E.g. N/O contact, PNP, with cable



Technical data		Download CAD data → www.festo.com						
Size		4	6.5	M5	M8	M12	M18	M30
Rated operating distance	Flush [mm]	0.8	1.5	0.8	1.5	2	5	10
	Non-flush [mm]	–	–	–	2.5	4	8	15
Switching output		PNP						
		NPN						
Switching element function		N/O contact						
		N/C contact						
Mounting		Flush						
		–					Non-flush	
Type of mounting		Clamped			Via lock nut			
Electrical connection		Cable, 3-wire						
		Plug M8x1, 3-pin				Plug M12x1, 3-pin		
Operating voltage range	[V DC]	10 ... 30						
Max. output current	[mA]	200						
∅/length	[mm]	8/42 (4/25) ¹⁾	8/45 (6.5/35) ¹⁾	8/42 (5/25) ¹⁾	8/45 (8/35) ¹⁾	12/45 (12/35) ¹⁾	18/48.5 (18/35) ¹⁾	30/48.5 (30/35) ¹⁾
Max. connecting cable length	[m]	2.5						

1) Value in brackets for electrical connection via cable.

Pin allocation to EN 60947-5-2

M8x1, 3-pin

N/O contact and N/C contact			
	Pin	Wire colour	Allocation
	1	Brown	+
	3	Blue	–
	4	Black	Output

M12x1, 3-pin

N/O contact			
	Pin	Wire colour	Allocation
	1	Brown	+
	3	Blue	–
	4	Black	Output

N/C contact			
	Pin	Wire colour	Allocation
	1	Brown	+
	3	Blue	–
	2	White	Output

Operating conditions

Ambient temperature	[°C]	–25 ... +70
Ambient temperature with flexible cable installation	[°C]	–5 ... +70

Materials

	M4 ... M8	M12 ... M30
Housing	High-alloy stainless steel	Nickel-plated brass
Cable sheath	PUR	

Technical data – With standard switching distance, polyamide housing

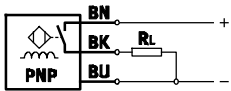

E.g. N/O contact, PNP, with cable

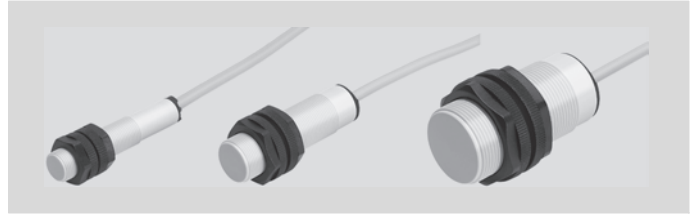

Technical data		Download CAD data → www.festo.com		
Size		M12	M18	M30
Rated operating distance	Flush [mm]	2	5	10
	Non-flush [mm]	4	8	15
Switching output		PNP		
		NPN		
Switching element function		N/O contact		
Mounting		Flush		
		Non-flush		
Type of mounting		Via lock nut		
Electrical connection		Cable, 3-wire		
Operating voltage range	[V DC]	10 ... 30		
Max. output current	[mA]	200		
∅/length	[mm]	12/60	18/60	30/60
Max. connecting cable length	[m]	2.5		

Operating conditions		
Ambient temperature	[°C]	-25 ... +70
Ambient temperature with flexible cable installation	[°C]	0 ... +70

Materials		
Housing		PA
Cable sheath		PVC

Order code – With standard switching distance

SIEN							L
Type							
SIEN	Proximity sensor with standard switching distance						
Design/size							
4; 6.5	Round O.D. 4 or 6.5 mm						
M5, M8, M12, M18, M30	Metric thread M5, M8, M12, M18, M30						
Mounting							
B	Flush						
NB	Non-flush 1						
Switching output							
P	PNP						
N	NPN						
Switching element function							
S	N/O contact						
O	N/C contact						
Electrical connection							
K	Cable						
S	Plug						
Display							
L	Switching status						
Version							
-	Basic design						
PA	Polyamide housing 2						

1 Only with design/size M8 ... M30.

2 Only with design/size M12 ... M30,
and switching element function S,
and electrical connection K.

Ordering – Product options

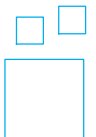





Configurable product

This product and all its options can be ordered using the configurator.

The configurator can be found under Products on the DVD or
→ www.festo.com/catalogue/...

Enter the type code in the search field.

★ Quick ordering

Size	Electrical connection	Part No.	Type
M5	 Cable	150370	SIEN-M5B-PS-K-L
	 Plug	150371	SIEN-M5B-PS-S-L
M8	 Cable	150386	SIEN-M8B-PS-K-L
	 Plug	150387	SIEN-M8B-PS-S-L

Proximity sensors SIE..., inductive

Accessories

SIE...

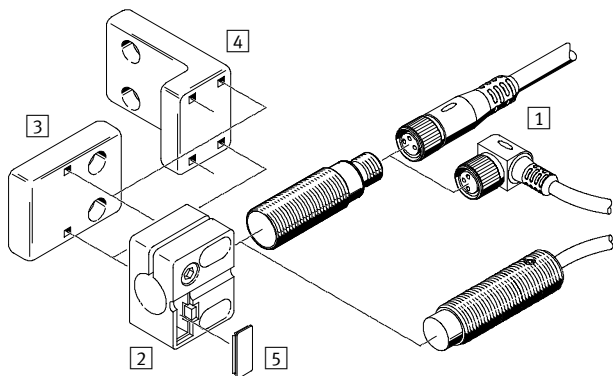

Mounting components and accessories		→ Page/online
1	Connecting cable NEBU	758
2	Sensor bracket SIEZ...B	758
3	Sensor bracket SIEZ-UV	758

Mounting components and accessories		→ Page/online
4	Sensor bracket SIEZ-UH	758
5	Inscription label SIEZ-LB	758

Accessories – Ordering data

	Cable length [m]		Part No.	Type
1 Connecting cable Technical data → 949				
Straight socket				
	2.5	★	541333	NEBU-M8G3-K-2.5-LE3
	5	★	541334	NEBU-M8G3-K-5-LE3
	2.5		541363	NEBU-M12G5-K-2.5-LE3
	5		541364	NEBU-M12G5-K-5-LE3
	2.5		550326	NEBU-M12G5-K-2.5-LE4 ¹⁾
	5		541328	NEBU-M12G5-K-5-LE4 ¹⁾
Angled socket				
	2.5	★	541338	NEBU-M8W3-K-2.5-LE3
	5	★	541341	NEBU-M8W3-K-5-LE3
	2.5		541367	NEBU-M12W5-K-2.5-LE3
	5		541370	NEBU-M12W5-K-5-LE3
	2.5		550325	NEBU-M12W5-K-2.5-LE4 ¹⁾
	5		541329	NEBU-M12W5-K-5-LE4 ¹⁾

1) For connecting proximity sensor SIE...M12/M18/M30 in N/C contact version with plug.

	For design	Part No.	Type
2 Sensor bracket with stop for flush mounting			
	M8	538346	SIEZ-B-8
	M12	538348	SIEZ-B-12
	M18	538350	SIEZ-B-18
	M30	538352	SIEZ-B-30
3 Sensor bracket without stop			
	4	538343	SIEZ-NB-4
	6.5	538344	SIEZ-NB-6,5
	M8	538345	SIEZ-NB-8
	M12	538347	SIEZ-NB-12
	M18	538349	SIEZ-NB-18
	M30	538351	SIEZ-NB-30
	M12, M18	538355	SIEZ-UV
	4 Sensor bracket without stop		
	M12, M18	538354	SIEZ-UH
	5 Inscription label		
	M12 ... M30	538353	SIEZ-LB

Proximity sensors SIES-8M, inductive for T-slot

FESTO



- Flush in T-slot, insertable from above
- Position sensing for electric axes EGC, EGSK, EGSP and grippers with T-slot
- Switching output PNP or NPN
- 2 LEDs for visibility irrespective of the direction from which the axis approaches the sensor

→ www.festo.com/catalogue/sies-8m

Product range overview

Version	Type	Operating voltage	Switching output	Design
Standard switching distance	SIES Special design	10 ... 30 V DC	PNP NPN	For T-slot

Technical data

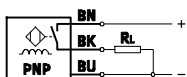

E.g. N/O contact, PNP, with cable

Technical data		Download CAD data → www.festo.com
Rated operating distance	[mm]	1.5
Switching output		PNP or NPN
Switching element function		N/O contact or N/C contact
Type of mounting		Screw-clamped in slot, insertable from above, flush with T-slot
Electrical connection		Cable, 3-wire
		Cable with plug M8x1, 3-pin, rotatable thread
Operating voltage range	[V DC]	10 ... 30
Max. output current	[mA]	150
Length/width/height	[mm]	5/5/32

Operating conditions	
Ambient temperature	[°C] -25 ... +70
Ambient temperature with flexible cable installation	[°C] -5 ... +70

Materials	SIES-8M-...-OE	SIES-8M-...-M8D
Housing	PA, PUR, high-alloy stainless steel	PA, PUR, nickel-plated brass, high-alloy stainless steel
Cable sheath	TPE-U (PU)	

Ordering – Product options

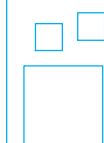

Configurable product

This product and all its options can be ordered using the configurator.

The configurator can be found under Products on the DVD or

→ www.festo.com/catalogue/...

Enter the type code in the search field.

Technical data

Pin allocation

Cable

PNP, N/O contact

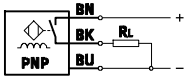

NPN, N/O contact

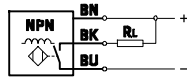

Plug

PNP, N/O contact

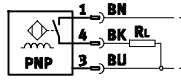

NPN, N/O contact

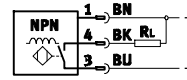

PNP, N/C contact

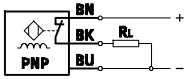

NPN, N/C contact

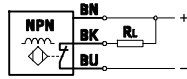

PNP, N/C contact

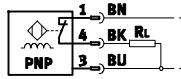

NPN, N/C contact

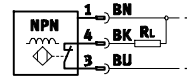

Wire colours

BN = Brown

BK = Black

BU = Blue

Order code – Special design

		SIES	8M		24V	K		
Type								
SIES	Sensor, special design							
Design								
8M	For T-slot							
Switching output								
P	PNP							
N	NPN							
Switching element function								
S	N/O contact							
O	N/C contact							
Rated operating voltage								
24V	24 V DC							
Cable characteristics								
K	Standard + energy chain							
Cable length								
0.3	0.3 m	[2]						
2.5	2.5 m	[2]						
5	5 m	[2]						
7.5	7.5 m	[1]						
10	10 m	[2]						
Electrical connection								
OE	Cable, 3-wire, open end							
M8D	Cable with plug M8x1, 3-pin, rotatable thread							

[1] Only with electrical connection OE



[2] Only with electrical connection M8D

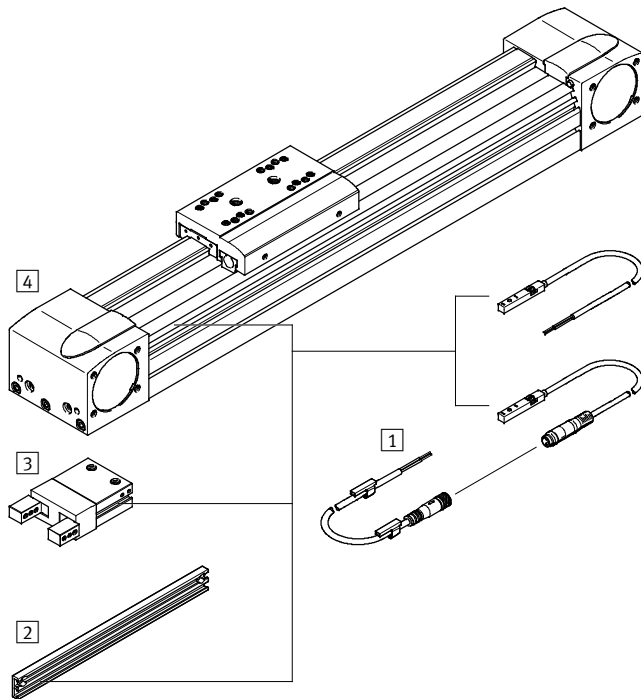

Accessories



Mounting components and accessories		→ Page/online
1	Connecting cable NEBU-M8...3	761
2	Sensor bracket SIEZ-8M	761
3	Gripper with T-slot, e.g. parallel gripper HGP	gripper
4	Electric axes, e.g. toothed belt axis EGC-...-TB	egc egsk egsp
-	Slot cover	761

Accessories – Ordering data

	Cable length [m]	Part No.	Type
1 Connecting cable			
Straight socket		Technical data → 949	
	2.5	★ 541333	NEBU-M8G3-K-2.5-LE3
	5	★ 541334	NEBU-M8G3-K-5-LE3
	10	★ 541332	NEBU-M8G3-K-10-LE3
Angled socket			
	2.5	★ 541338	NEBU-M8W3-K-2.5-LE3
	5	★ 541341	NEBU-M8W3-K-5-LE3
	10	★ 541335	NEBU-M8W3-K-10-LE3

	Length [m]	Part No.	Type
2 Sensor bracket			
	0.2	551406	SIEZ-8M-200
	0.4	551407	SIEZ-8M-400
Slot cover for T-slot			
	2x 0.5	563360	ABP-5-S1

Pressure sensors SDE1, with display

FESTO



- Five pressure measuring ranges
- Measurement of relative or differential pressure
- Switching outputs PNP, NPN and with analogue current or voltage output
- LCD or illuminated LCD display
- Wide range of connection and mounting options

→ www.festo.com/catalogue/sde1

Product range overview

Method of measurement	Pressure measuring range [bar]	Measured variable	Switching element function	Switching function	Pneumatic connection	Electrical connection	Electrical output	
							Digital	Analogue
Piezoresistive pressure sensor with display	-1 ... 0, -1 ... +1, 0 ... 2, 0 ... 6, 0 ... 10	Relative pressure Differential and relative pressure ¹⁾	Switchable	Freely programmable	R $\frac{1}{8}$ R $\frac{1}{4}$ G $\frac{1}{8}$ QS-4	Plug M8x1 Plug M12x1	PNP	-
							2x PNP	-
							PNP	0 ... 10 V
							PNP	4 ... 20 mA
							2x PNP	4 ... 20 mA
							NPN	-
							2x NPN	-
							NPN	0 ... 10 V
NPN	4 ... 20 mA							

1) Versions with push-in connector QS-4

10

Product options

- LCD display with backlighting (optimised operation)
- Illuminated LCD display (optimised reading)

- Type of mounting:
On service unit, via H-rail, via wall/surface bracket, front panel mounting

- Pneumatic connection:
Male thread, female thread, push-in connector

- Connecting cable

Technical data

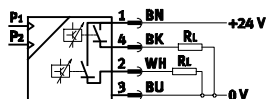

E.g. with 2 switching outputs PNP



Technical data		Download CAD data → www.festo.com						
Type of mounting		On service unit	Via H-rail	Via wall/surface bracket	Front panel mounting			
Pneumatic connection		R $\frac{1}{4}$	G $\frac{1}{8}$	G $\frac{1}{8}$	-			
		-	-	QS-4	QS-4			
Operating voltage range	[V DC]	15 ... 30						
Max. output current	[mA]	150						
Measured variable		Relative pressure			Relative pressure Differential pressure ¹⁾			
Switching function		Freely programmable						
Switching element function		Switchable						
Electrical connection		Plug M8x1	Plug M12x1	Plug M8x1	Plug M12x1	Plug M8x1	Plug M12x1	
Length/width/height	[mm]	78/32/46	87/32/46	78/32/35	87/32/35	78/32/35	87/32/35	
Front panel cutout	[mm]	-		-		85.5 x 36		

1) Versions with push-in connector QS-4

Operating conditions		V1	D2	D6	D10
SDE1-					
Pressure measuring range	[bar]	-1 ... 0	0 ... +2	0 ... +6	0 ... +10
Threshold value setting range	[%]	2 ... 99.8			
Hysteresis setting range	[%]	0 ... 90			
Operating medium		Compressed air to ISO 8573-1:2010 [7:4:4]			
Note on operating/pilot medium		Lubricated operation possible (in which case lubricated operation will always be required)			
Ambient temperature	[°C]	0 ... 50			
Temperature of medium	[°C]	0 ... 50			

Materials	
Housing	PA, POM reinforced

Ordering – Product options

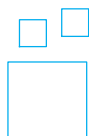

Configurable product

This product and all its options can be ordered using the configurator.

The configurator can be found under Products on the DVD or
→ www.festo.com/catalogue/...

Enter the type code in the search field.

Pressure sensors SDE1, with display

Order code

		SDE1	-		-	G2	-		-		-		-		-	
Type																
SDE1	Pressure sensor with display															
Pressure measuring range																
V1	-1 ... 0 bar															
D2	0 ... +2 bar															
D6	0 ... +6 bar															
D10	0 ... +10 bar															
Absolute accuracy																
G2	Accuracy 2%															
Pneumatic connection and mounting																
R14	Male thread R $\frac{1}{4}$, mounting on service unit															
H18	Female thread G $\frac{1}{8}$, H-rail mounting															
W18	Female thread G $\frac{1}{8}$, wall or surface mounting															
WQ4	Push-in connector QS-4, wall or surface mounting															
FQ4	Push-in connector QS-4, front panel mounting															
Display and setting																
C	LCD display with backlighting (optimised operation)															
L	Illuminated LCD display (optimised reading)															
Electrical output																
P1	1 switching output PNP															
P2	2 switching outputs PNP															
PU	1 switching output PNP, 1 analogue output 0 ... 10 V															
pi	1 switching output PNP, 1 analogue output 4 ... 20 mA															
N1	1 switching output NPN															
N2	2 switching outputs NPN															
NU	1 switching output NPN, 1 analogue output 0 ... 10 V															
NI	1 switching output NPN, 1 analogue output 4 ... 20 mA															
Electrical connection																
M 8	Plug M8x1															
M12	Plug M12x1															

Accessories

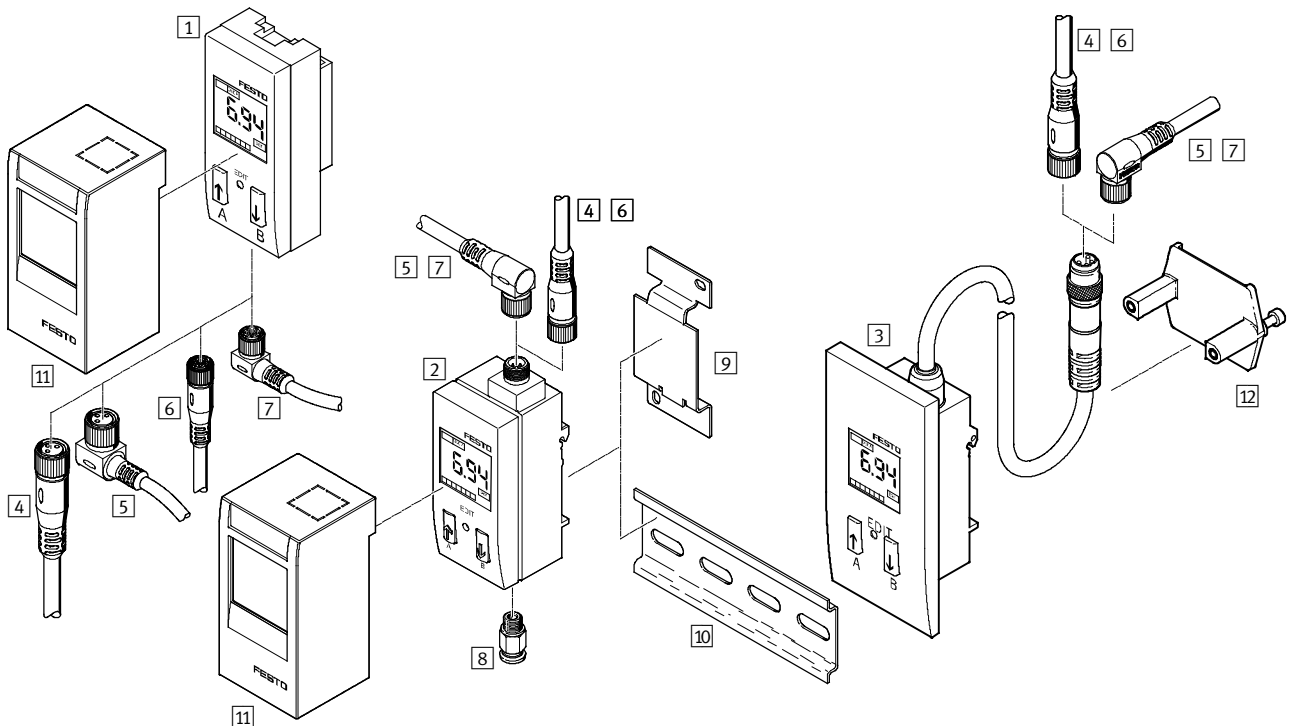





		→ Page/ online
1	Pressure sensor SDE1-...-R14	763
2	Pressure sensor SDE1-...-H18, SDE1-...-W18	763
3	Pressure sensor SDE1-...-FQ4	763
4	Connecting cable NEBU-M12G, straight socket	766
5	Connecting cable NEBU-M12W, angled socket	766
6	Connecting cable NEBU-M8G, straight socket	766
7	Connecting cable NEBU-M8W, angled socket	766

		→ Page/ online
8	Push-in fitting QS-1/8	766
9	Adapter plate SDE1-...-W..	sde1-w
10	Mounting rail to EN 60715	nrh
11	Safety guard SDE1-SH	sde1-sh
12	Clamping plate (included in the scope of delivery of SDE1-...-FQ4)	-

Pressure sensors SDE1, with display

Accessories – Ordering data

	Number of wires	Cable length [m]	Part No.	Type	
4/5 Connecting cables M12x1, straight socket					Technical data → 949
	3	2.5	541363	NEBU-M12G5-K-2.5-LE3	
		5	541364	NEBU-M12G5-K-5-LE3	
	4	2.5	550326	NEBU-M12G5-K-2.5-LE4	
		5	541328	NEBU-M12G5-K-5-LE4	
Angled socket					Technical data → 949
	3	2.5	541367	NEBU-M12W5-K-2.5-LE3	
		5	541370	NEBU-M12W5-K-5-LE3	
	4	2.5	550325	NEBU-M12W5-K-2.5-LE4	
		5	541329	NEBU-M12W5-K-5-LE4	
6/7 Connecting cables M8x1, straight socket					Technical data → 949
	3	2.5	★ 541333	NEBU-M8G3-K-2.5-LE3	
		5	★ 541334	NEBU-M8G3-K-5-LE3	
	4	2.5	541342	NEBU-M8G4-K-2.5-LE4	
		5	541343	NEBU-M8G4-K-5-LE4	
Angled socket					Technical data → 949
	3	2.5	★ 541338	NEBU-M8W3-K-2.5-LE3	
		5	★ 541341	NEBU-M8W3-K-5-LE3	
	4	2.5	541344	NEBU-M8W4-K-2.5-LE4	
		5	541345	NEBU-M8W4-K-5-LE4	
8 Push-in fittings					Technical data → 916
	4		★ 186095	QS-G $\frac{1}{8}$ -4	
	6		★ 186096	QS-G $\frac{1}{8}$ -6	
	8		★ 186098	QS-G $\frac{1}{8}$ -8	



- Programmable and configurable pressure switch for simple pressure sensing tasks
- Teach-in function for programming
- Integrated microprocessor
- Switching status indicated by an LED visible from all sides
- ★ Quick ordering of basic designs → 770

→ www.festo.com/catalogue/sde5

Product range overview

Method of measurement	Pressure measuring range [bar]	Switching element function	Switching function	Pneumatic connection	Electrical output	Electrical connection
Piezoresistive	-1 ... 0, -1 ... 1, 0 ... 2, 0 ... 6, 0 ... 10	N/O contact, N/C contact switchable	Threshold value, window comparator	QS-4, QS-6, QS-1/4", QS-5/32"	Switching output PNP, switching output NPN, analogue output	Plug M8x1, 3-pin; cable, 3-wire

Product options

- Threshold value with fixed hysteresis
- Threshold value with variable hysteresis
- Window comparator with fixed hysteresis
- Connecting cable
- Teach-in points permanently set

Switching functions

Operating mode 0

Threshold value with fixed hysteresis, 1 teach-in pressure

N/O switching element

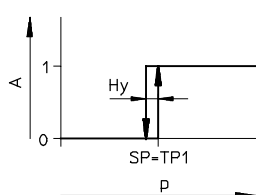

N/C switching element

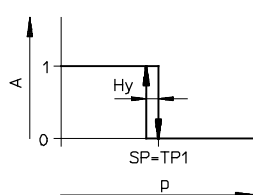

Operating mode 2

Threshold value with variable hysteresis, 2 teach-in pressures

N/O switching element

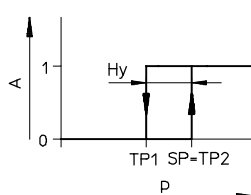

N/C switching element

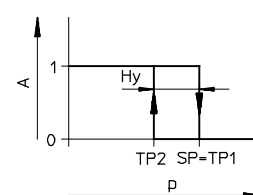

Operating mode 1

Threshold value with fixed hysteresis, 2 teach-in pressures

N/O switching element

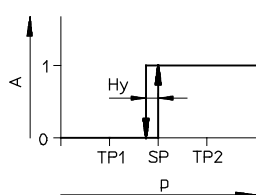

N/C switching element

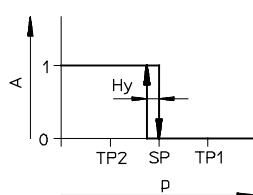

Operating mode 3

Window comparator with fixed hysteresis, 2 teach-in pressures

N/O switching element

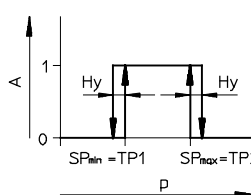

N/C switching element

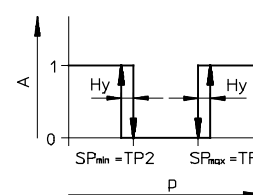

- A Binary output signal
- p Pressure
- SP Switching point
- TP Teach-in pressure
- Hy Hysteresis

Technical data

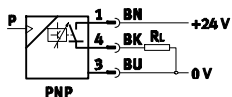

E.g. N/O contact, PNP, with plug

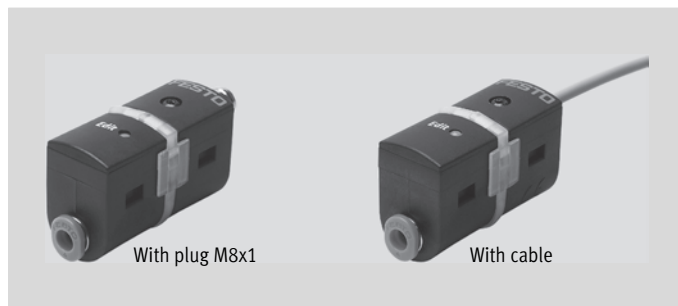

With plug M8x1

With cable

Technical data		Download CAD data → www.festo.com	
Electrical connection		Plug M8x1, 3-pin	Cable
Pneumatic connection		QS-4	
		QS-6	
		QS-1/4"	
Operating voltage range	[V DC]	15 ... 30	
Max. output current	[mA]	100	
Switching output		PNP	
		NPN	
Switching function		Freely programmable (switching/teach-in function, N/O contact, N/C contact)	
		Threshold value with fixed hysteresis	
		Threshold value with variable hysteresis	
		Window comparator with fixed hysteresis	
Switching element function		N/C contact	
		N/O contact	
		Switchable	
Output characteristic	[V]	0 ... 10	
Length/width/height	[mm]	56/16/25	45/16/25

Operating conditions			
SDE5-		V1	D10
Pressure measuring range	[bar]	-1 ... 0	0 ... +10
Threshold value setting range	[%]	0 ... 100	
Operating medium		Compressed air to ISO 8573-1:2010 [7:4:4]	
Note on operating/pilot medium		Lubricated operation possible (in which case lubricated operation will always be required)	
Ambient temperature	[°C]	0 ... +50	
Temperature of medium	[°C]	0 ... +50	

Materials	
Housing	PA, POM

Ordering – Product options

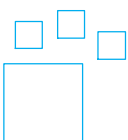

Configurable product

This product and all its options can be ordered using the configurator.

The configurator can be found under Products on the DVD or
→ www.festo.com/catalogue/...

Enter the type code in the search field.

Order code

SDE5							
Sensor function							
SDE5	Pressure sensor						
Pressure measuring range							
V1	-1 ... 0 bar						
D10	0 ... 10 bar						
Pressure input							
-	Relative pressure						
Z	Differential pressure						
Output function							
FP	Freely programmable, N/O contact, N/C contact						
O	Threshold value with fixed hysteresis, 1 teach-in pressure, N/O contact						
C	Threshold value with fixed hysteresis, 1 teach-in pressure, N/C contact						
O1	Threshold value with fixed hysteresis, 2 teach-in pressures, N/O contact						
O2	Threshold value with variable hysteresis, 2 teach-in pressures, N/O contact						
O3	Window comparator with fixed hysteresis, 2 teach-in pressures, N/O contact						
C3	Window comparator with fixed hysteresis, 2 teach-in pressures, N/C contact						
NF	No binary switching function (analogue output)						
Pneumatic connection							
Push-in connector at both ends							
Q4	For tubing O.D. 4 mm						
Q6	For tubing O.D. 6 mm						
Push-in connector at one end							
Q4E	For tubing O.D. 4 mm					1	
Q6E	For tubing O.D. 6 mm					1	
T14E	For tubing O.D. 1/4"					1	
Electrical output							
P	1 switching output PNP					2	
N	1 switching output NPN					2	
V	1 analogue output 0 ... 10 V					3	
Electrical connection							
K	Cable, 2.5 m						
M8	Plug M8, 3 pin						
Electrical accessories							
-	Without electrical accessories						
G	Connecting cable, straight socket, 2.5 m					4	

- 1 Not in combination with supply port Z
 2 Not in combination with output function NF

- 3 Only in combination with output function NF
 4 Only in combination with M8

★ Quick ordering

Pressure measuring range [bar]	Electrical output	Part No.	Type
Freely programmable (switching/teach-in function, N/O contact, N/C contact)			
0 ... -1	Plug M8x1, 3-pin	542887	SDE5-V1-FP-Q6-P-M8
0 ... +10	Plug M8x1, 3-pin	542900	SDE5-D10-FP-Q4E-P-M8
		542897	SDE5-D10-FP-Q6E-P-M8
		542898	SDE5-D10-FP-Q6-P-M8
	Cable, 3-wire	542901	SDE5-D10-FP-Q4E-P-K
		542899	SDE5-D10-FP-Q6-P-K
Threshold value with fixed hysteresis, 1 teach-in pressure, N/O contact			
0 ... -1	Plug M8x1, 3-pin	527460	SDE5-V1-O-Q4E-P-M8
		527461	SDE5-V1-O-Q6E-P-M8
		527457	SDE5-V1-O-Q4-P-M8
		527458	SDE5-V1-O-Q6-P-M8
0 ... +2	Cable, 3-wire	542888	SDE5-D2-O-Q6E-P-K
0 ... +10	Plug M8x1, 3-pin	527466	SDE5-D10-O-Q4E-P-M8
		527467	SDE5-D10-O-Q6E-P-M8
		527463	SDE5-D10-O-Q4-P-M8
		527464	SDE5-D10-O-Q6-P-M8
	Cable, 3-wire	542890	SDE5-D10-O-Q6E-P-K
N/C contact			
0 ... +10	Plug M8x1, 3-pin	542889	SDE5-D10-C-Q4E-P-M8
		542894	SDE5-D10-C-Q6E-P-M8
		Cable, 3-wire	542895

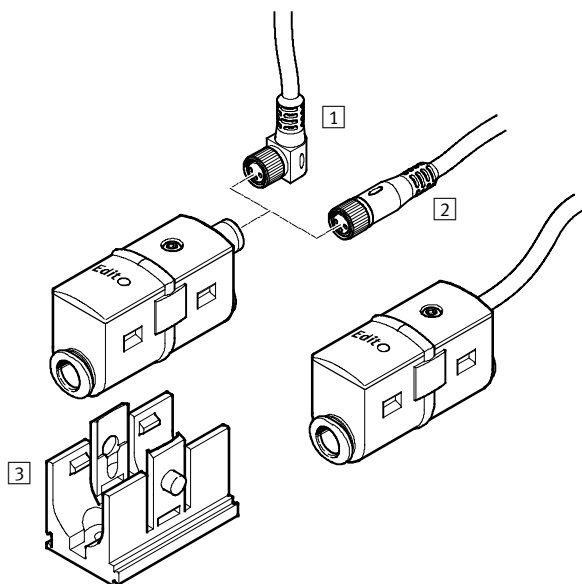

Pressure measuring range [bar]	Electrical output	Part No.	Type
Threshold value with fixed hysteresis, 2 teach-in pressures with mean value calculation, N/O contact			
0 ... -1	Plug M8x1, 3-pin	542886	SDE5-V1-O1-Q6-P-M8
Threshold value with variable hysteresis, 2 teach-in pressures, N/O contact			
0 ... +10	Plug M8x1, 3-pin	542891	SDE5-D10-O2-Q6E-P-M8
		542892	SDE5-D10-O2-Q6-P-M8

Accessories



	→ Page/ online
1 Connecting cable NEBU-M8W3, angled socket	770
2 Connecting cable NEBU-M8G3, straight socket	770
3 Wall bracket (included in the scope of delivery)	-

Accessories – Ordering data

	Cable length [m]	Part No.	Type
1/2 Connecting cables M8x1, angled socket			
Technical data → 949			
	2.5	★ 541338	NEBU-M8W3-K-2.5-LE3
	5	★ 541341	NEBU-M8W3-K-5-LE3
	10	★ 541335	NEBU-M8W3-K-10-LE3
Straight socket			
Technical data → 949			
	2.5	★ 541333	NEBU-M8G3-K-2.5-LE3
	5	★ 541334	NEBU-M8G3-K-5-LE3
	10	★ 541332	NEBU-M8G3-K-10-LE3



- Diffuse sensors and retro-reflective sensors
- Diffuse sensors with background suppression
- Fibre-optic units
- Distance sensors
- Laser contrast sensors, diffuse sensors and retro-reflective sensors
- Colour sensor
- Working ranges up to 20 m
- Adjustment via teach-in or potentiometer

→ www.festo.com/catalogue/soe

Product range overview

Version	Type	Operating voltage	Switching output	Analogue output	→ Page/online
Diffuse sensor	SOEG-RT Basic design	10 ... 36 V DC 10 ... 30 V DC	PNP NPN	–	772
	SOEG-RTZ with cylindrical light beam		PNP NPN	–	soeg
Sensor with background suppression	SOEG-RTH		PNP NPN	–	soeg
Retro-reflective sensor	SOEG-RSP Basic design	10 ... 36 V DC 10 ... 30 V DC	PNP NPN	–	774
	SOEG-RSG for transparent objects		PNP NPN	–	soeg
Through-beam sensor	SOEG-S Transmitter	10 ... 36 V DC 10 ... 30 V DC	–	–	776
	SOEG-E Receiver		PNP NPN	–	776
Fibre-optic unit	SOEG-L Basic design	10 ... 30 V DC	PNP NPN	–	778
Distance sensor	SOEG-RTD	15 ... 30 V DC	PNP	0 ... 10 V	soeg
Laser diffuse sensor	SOEL-RT Contrast sensor	10 ... 30 V DC	PNP NPN	–	780
Laser sensor with background suppression	SOEL-RTH		PNP NPN	–	780
Laser retro-reflective sensor	SOEL-RSP	10 ... 30 V DC	PNP NPN	–	782
Laser distance sensor	SOEL-RTD	16 ... 30 V DC	2x PNP	4 ... 20 mA	784
		18 ... 28 V DC	–	0 ... 10 V	
Colour sensor	SOEC-RT	10 ... 30 V DC	3x PNP	–	soec

Technical data

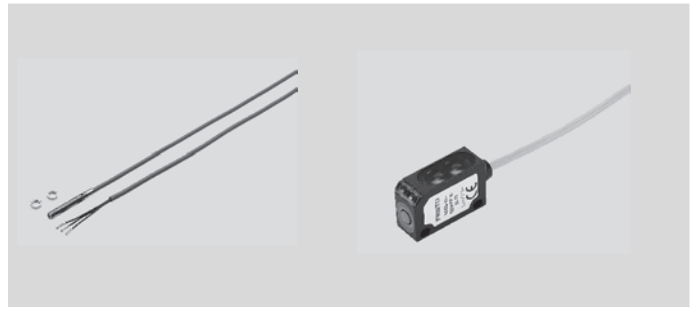
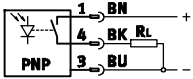
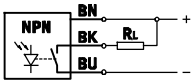
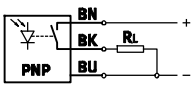

Technical data		Download CAD data → www.festo.com						
Size		∅ 4 mm	M5	M12x1	M18x1, straight	M18x1, angled	20x32x12 mm	30x30x15 mm
Working range	[mm]	50		70 ... 300	40 ... 600	0 ... 600	10 ... 300	0 ... 600
Type of light		Infrared		Red			Red	Infrared
Setting options		-		Potentiometer			Teach-in Teach-in via electrical connection	Potentiometer

Electrical data		Download CAD data → www.festo.com						
Size		∅ 4 mm	M5	M12x1	M18x1, straight	M18x1, angled	20x32x12 mm	30x30x15 mm
Electrical connection	Cable	3-wire			4-wire	3-wire	4-wire	3-wire
	Plug	M8x1, 3-pin		M12x1, 3-pin	M12x1, 4-pin	M12x1, 3-pin	M8x1, 4-pin	M8x1, 3-pin
Operating voltage range	[V DC]	10 ... 30		10 ... 36		10 ... 30		
Max. output current	[mA]	100		200		100		200
Max. switching frequency	[Hz]	250		1,000		1,000		
Protection against short circuit		Pulsed						
Reverse polarity protection		For all electrical connections						
Protection class		IP67		IP65, IP67		IP67		IP65

Operating conditions		Download CAD data → www.festo.com						
Size		∅ 4 mm	M5	M12x1	M18x1, straight	M18x1, angled	20x32x12 mm	30x30x15 mm
Ambient temperature	[°C]	0 ... +55		-25 ... +55		-20 ... +60		-25 ... +55
Ambient temperature with flexible cable installation	[°C]	0 ... +55		-5 ... +55		-5 ... +60		-5 ... +55

Materials		Download CAD data → www.festo.com						
Size		∅ 4 mm	M5	M12x1	M18x1, straight	M18x1, angled	20x32x12 mm	30x30x15 mm
Housing		High-alloy stainless steel		Chrome-plated brass		ABS		PBT, reinforced
Cable sheath		TPE-U (PUR)						

Order code

		SOE	G	RT					
Type									
SOE	Opto-electronic sensor								
Design									
G	Standard sensor								
Function									
RT	Diffuse sensor								
Design, size, version									
4	Round, Ø 4 mm	1							
M5	Round, M5	1							
M12	Round, M12	1							
M18	Round, M18, beam exit straight	2							
M18W	Round, M18, beam exit angled	2							
Q20	Block design, 20x32x12 mm	3							
Q30	Block design, 30x30x15 mm	4							
Switching output									
PS	PNP, N/O contact								
NS	NPN, N/O contact								
PA	PNP, antivalent								
NA	NPN, antivalent								
PP	PNP, switchable								
NP	NPN, switchable								
Electrical connection									
K	Cable								
S	Plug								
Display									
L	1 LED	5							
2L	2 LEDs	6							
Options									
	Standard design								
Tl	Teach-in by means of a button and via electrical connection	7							

- 1 Only with switching output PS, NS
 2 Only with switching output PA, NA, PS, NS
 3 Only with switching output PP, NP
 4 Only with switching output PS, NS
 5 Only with design, size Ø 4 mm, M5
 6 Only with design, size M12, M18, Q20, Q30
 7 Only with design, size Q20, 20x32x12 mm

Ordering – Product options

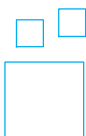

Configurable product

This product and all its options can be ordered using the configurator.

The configurator can be found under Products on the DVD or
 → www.festo.com/catalogue/...

Enter the type code in the search field.

Technical data

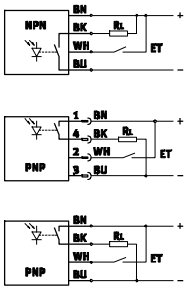

Technical data				Download CAD data → www.festo.com		
Size	M12x1	M18x1, straight	M18x1, angled	20x32x12 mm	30x30x15 mm	50x50x17 mm
Working range [mm]	1,500	2,000	2,000	0 ... 2,500	0 ... 2,000	0 ... 5,500
Type of light	Red polarised					
Setting options	-			Teach-in Teach-in via electrical connection ¹⁾	Potentiometer	

1) Cost-optimised variant without teach-in and programming functionality available

Electrical data						
Size	M12x1	M18x1, straight	M18x1, angled	20x32x12 mm	30x30x15 mm	50x50x17 mm
Electrical connection	Cable	3-wire		4-wire	3-wire	4-wire
	Plug	M12x1, 3-pin		M8x1, 4-pin	M8x1, 3-pin	M12x1, 4-pin
Operating voltage range [V DC]	10 ... 36			10 ... 30		
Max. output current [mA]	200			100	200	
Max. switching frequency [Hz]	1,000					
Protection against short circuit	Pulsed					
Reverse polarity protection	For all electrical connections					
Protection class	IP65, IP67			IP67	IP65	IP67

Operating conditions						
Size	M12x1	M18x1, straight	M18x1, angled	20x32x12 mm	30x30x15 mm	50x50x17 mm
Ambient temperature [°C]	-25 ... +55			-20 ... +60	-25 ... +55	-20 ... +60
Ambient temperature with flexible cable installation [°C]	-5 ... +55			-5 ... +60	-5 ... +55	-5 ... +60

Materials						
Size	M12x1	M18x1, straight	M18x1, angled	20x32x12 mm	30x30x15 mm	50x50x17 mm
Housing	Chrome-plated brass			ABS	PBT, reinforced	ABS
Cable sheath	TPE-U (PUR)					

Order code

		SOE	G	-	RSP	-		-		-		-		-	
Type															
SOE	Opto-electronic sensor														
Design															
G	Standard sensor														
Function															
RSP	Retro-reflective sensor														
Design, size, version															
M12	Round, M12	1													
M18	Round, M18, beam exit straight	1													
M18W	Round, M18, beam exit angled	1													
Q20	Block design, 20x32x12 mm	2													
Q30	Block design, 30x30x15 mm	1													
Q50	Block design, 50x50x17 mm	3													
Switching output															
PS	PNP, N/O contact														
NS	NPN, N/O contact														
PA	PNP, antivalent														
NA	NPN, antivalent														
PP	PNP, switchable														
NP	NPN, switchable														
Electrical connection															
K	Cable														
S	Plug														
Display															
2L	2 LEDs														
3L	3 LEDs	4													
Options															
	Standard design														
TI	Teach-in by means of a button and via electrical connection	5													

- 1 Only with switching output PS, NS
 2 Only with switching output PS, PP, NP
 3 Only with switching output PA, NA
 4 Only with design, size Q50
 5 Only with design, size Q20, 20x32x12 mm, not with switching output PS

Ordering – Product options



Configurable product

This product and all its options can be ordered using the configurator.

The configurator can be found under Products on the DVD or
 → www.festo.com/catalogue/...

Enter the type code in the search field.

Technical data

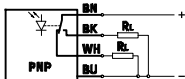
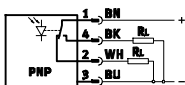
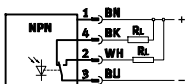

Technical data		Download CAD data → www.festo.com				
Size		M18x1, straight	M18x1, angled	20x32x12 mm	30x30x15 mm	50x50x17 mm
Working range	[mm]	20,000	20,000	6,000	2,000	15,000
Type of light		Red			Infrared	
Setting options		-		Teach-in Teach-in via electrical connection	Potentiometer	

Electrical data						
Size		M18x1, straight	M18x1, angled	20x32x12 mm	30x30x15 mm	50x50x17 mm
Electrical connection	Transmitter	Cable	3-wire	4-wire	3-wire	4-wire
		Plug	M12x1, 3-pin	M8x1, 4-pin	M8x1, 3-pin	M12x1, 4-pin
	Receiver	Cable	4-wire	4-wire	3-wire	4-wire
		Plug	M12x1, 4-pin	M8x1, 4-pin	M8x1, 3-pin	M12x1, 4-pin
Operating voltage range	[V DC]	10 ... 36		10 ... 30		
Max. output current	[mA]	200		100	200	
Max. switching frequency	[Hz]	1,000		500	1,000	
Protection against short circuit		Pulsed				
Reverse polarity protection		For all electrical connections				
Protection class		IP65, IP67		IP67	IP65	IP67

Operating conditions						
Size		M18x1, straight	M18x1, angled	20x32x12 mm	30x30x15 mm	50x50x17 mm
Ambient temperature	[°C]	-25 ... +55		-20 ... +60	-25 ... +55	-20 ... +60
Ambient temperature with flexible cable installation	[°C]	-5 ... +55		-5 ... +60	-5 ... +55	-5 ... +60

Materials						
Size		M18x1, straight	M18x1, angled	20x32x12 mm	30x30x15 mm	50x50x17 mm
Housing		Chrome-plated brass		ABS	PBT, reinforced	ABS
Cable sheath		TPE-U (PUR)				

Order code

		SOE	G	-		-		-		-		-		-	
Type															
SOE	Opto-electronic sensor														
Design															
G	Standard sensor														
Function															
S	Through-beam sensor, transmitter														
E	Through-beam sensor, receiver														
Design, size, version															
M18	Round, M18, beam exit straight	1													
M18W	Round, M18, beam exit angled	1													
Q20	Block design, 20x32x12 mm	2													
Q30	Block design, 30x30x15 mm	3													
Q50	Block design, 50x50x17 mm	4													
Switching output															
PS	PNP, N/O contact														
NS	NPN, N/O contact														
PA	PNP, antivalent														
NA	NPN, antivalent														
PP	PNP, switchable														
NP	NPN, switchable														
Electrical connection															
K	Cable														
S	Plug														
Display															
L	1 LED	5													
2L	2 LEDs														
3L	3 LEDs														
Options															
	Standard design														
Tl	Teach-in by means of a button and via electrical connection	6													

- 1 Only with switching output PA, NA, only with display 2L
 2 Only with switching output PP, NP, only with display 2L
 3 Only with switching output PS, NS, only with display 2L
 4 Only with switching output PA, only with display 3L
 5 Only with function S, transmitter
 6 Only with design, size Q20, 20x32x12 mm

Ordering – Product options

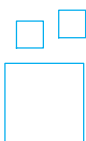

Configurable product

This product and all its options can be ordered using the configurator.

The configurator can be found under Products on the DVD or
 → www.festo.com/catalogue/...

Enter the type code in the search field.

Technical data

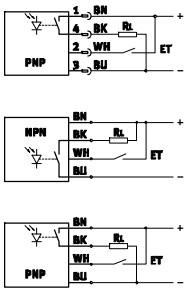

Technical data

Download CAD data → www.festo.com

Size	20x32x12 mm	30x30x15 mm
Working range [mm]	0 ... 250	0 ... 120
Type of light	Red	
Setting options	Teach-in Teach-in via electrical connection	Potentiometer

Electrical data

Size	20x32x12 mm	30x30x15 mm
Electrical connection	Cable	4-wire
	Plug	M8x1, 4-pin
Operating voltage range [V DC]	10 ... 30	
Max. output current [mA]	100	200
Max. switching frequency [Hz]	1,000	
Protection against short circuit	Pulsed	
Reverse polarity protection	For all electrical connections	
Protection class	IP67	IP65

Operating conditions

Size	20x32x12 mm	30x30x15 mm
Ambient temperature [°C]	0 ... +60	-25 ... +55
Ambient temperature with flexible cable installation [°C]	0 ... +60	-5 ... +55

Materials

Size	20x32x12 mm	30x30x15 mm
Housing	ABS	PBT, reinforced
Cable sheath	TPE-U (PUR)	

Order code

		SOE	G	-	L	-		-		-		-	2L	-	
Type															
SOE	Opto-electronic sensor														
Design															
G	Standard sensor														
Function															
L	Fibre-optic unit														
Design, size, version															
Q20	Block design, 20x32x12 mm													1	
Q30	Block design, 30x30x15 mm													2	
Switching output															
PA	PNP, antivalent														
NA	NPN, antivalent														
PP	PNP, switchable														
NP	NPN, switchable														
Electrical connection															
K	Cable														
S	Plug														
Display															
2L	2 LEDs														
Options															
	Standard design														
Tl	Teach-in by means of a button and via electrical connection													3	

- 1 Only with switching output PP, NP
 2 Only with switching output PA, NA
 3 Only with design, size Q20 with plug

Ordering – Product options

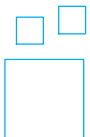

Configurable product

This product and all its options can be ordered using the configurator.

The configurator can be found under Products on the DVD or
 → www.festo.com/catalogue/...

Enter the type code in the search field.

Technical data

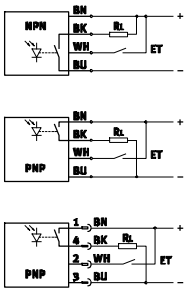

Technical data		Download CAD data → www.festo.com	
Size	20x32x12 mm	20x32x12 mm	50x50x17 mm
Method of measurement	Contrast sensor	With background suppression	
Working range [mm]	40 ... 150	30 ... 110	50 ... 300
Type of light	Laser, red		
Laser protection class	2		
Setting options	Teach-in Teach-in via electrical connection	Teach-in Teach-in via electrical connection	Potentiometer

Electrical data		Contrast sensor		With background suppression	
Method of measurement		Contrast sensor	With background suppression		
Size		20x32x12 mm	20x32x12 mm	50x50x17 mm	
Electrical connection	Cable	4-wire	4-wire	4-wire	
	Plug	M8x1, 4-pin	M8x1, 4-pin	M12x1, 4-pin	
Operating voltage range [V DC]		10 ... 30	10 ... 30		
Max. output current [mA]		100	100	200	
Max. switching frequency [Hz]		4,000	1,000	2,500	
Protection against short circuit		Pulsed			
Reverse polarity protection		For all electrical connections			
Protection class		IP67			

Operating conditions		Contrast sensor		With background suppression	
Method of measurement		Contrast sensor	With background suppression		
Size		20x32x12 mm	20x32x12 mm	50x50x17 mm	
Ambient temperature [°C]		-20 ... +60	-20 ... +60	-20 ... +45	
Ambient temperature with flexible cable installation [°C]		-5 ... +60	-5 ... +60	-5 ... +45	

Materials	
Housing	ABS
Cable sheath	TPE-P (PUR)

Order code

		SOE	L	-	RT	-	Q20	-		-		-	2L	-	TI
Type															
SOE	Opto-electronic sensor														
Design															
L	Laser sensor														
Function															
RT	Diffuse sensor														
Design, size, version															
Q20	Block design, 20x32x12 mm														
Switching output															
PP	PNP, switchable														
NP	NPN, switchable														
Electrical connection															
K	Cable														
S	Plug														
Display															
2L	2 LEDs														
Options															
TI	Teach-in by means of a button and via electrical connection														

Ordering – Product options

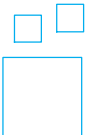

Configurable product

This product and all its options can be ordered using the configurator.

The configurator can be found under Products on the DVD or
 → www.festo.com/catalogue/...

Enter the type code in the search field.

Order code

		SOE	L	-	RSP	-		-		-		-		-	
Type															
SOE	Opto-electronic sensor														
Design															
L	Laser sensor														
Function															
RSP	Retro-reflective sensor														
Design, size, version															
Q20	Block design, 20x32x12 mm														1
Q50	Block design, 50x50x17 mm														2
Switching output															
PA	PNP, antivalent														
NA	NPN, antivalent														
PP	PNP, switchable														
NP	NPN, switchable														
Electrical connection															
K	Cable														
S	Plug														
Display															
2L	2 LEDs														1
3L	3 LEDs														2
Options															
	Standard design														
TI	Teach-in by means of a button and via electrical connection														3

- 1 Only with switching output PP, NP
 2 Only with switching output PA, NA
 3 Only with design, size Q50, 50x50x17

Ordering – Product options

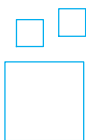

Configurable product

This product and all its options can be ordered using the configurator.

The configurator can be found under Products on the DVD or
 → www.festo.com/catalogue/...

Enter the type code in the search field.

Technical data

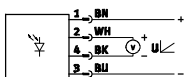

Technical data		Download CAD data → www.festo.com		
Size	50x50x17 mm			
Working range	[mm]	38 ... 58	44 ... 84	80 ... 300
Position measuring range	[mm]	20	40	220
Displacement resolution	[mm]	0.007	0.02	0.3
Type of light	Laser, red			
Laser protection class	2			
Setting options	-		-	Teach-in Teach-in via electrical connection

Electrical data		Size		
Size	50x50x17 mm			
Working range	[mm]	38 ... 58	44 ... 84	80 ... 300
Analogue output	[mA]	-	-	4 ... 20
	[V]	0 ... 10	0 ... 10	-
Electrical connection	Plug M1 2x1, 4-pin		Plug M1 2x1, 4-pin	Plug M1 2x1, 8-pin
Operating voltage range	[V DC]	18 ... 28	18 ... 28	16 ... 30
Max. load current at analogue voltage output	[mA]	3.0	3.0	-
Max. output current	[mA]	-	-	100
Measuring frequency	[Hz]	40	40	-
Max. switching frequency	[Hz]	-	-	1,000
Protection against short circuit	Pulsed			
Protection against incorrect polarity	For operating voltage		For operating voltage	For all electrical connections
Protection class	IP67			

Operating conditions	
Ambient temperature	[°C] 0 ... 45

Materials	
Housing	ABS

Order code

		SOE	L	-	RTD	-	Q50	-		-	S	-		-	
Type															
SOE	Opto-electronic sensor														
Design															
L	Laser sensor														
Function															
RTD	Distance sensor														
Design, size, version															
Q50	Block design, 50x50x17 mm														
Switching output															
PU	Analogue 0 ... 10 V														
PP	PNP, switchable														
Electrical connection															
S	Plug														
Display															
2L	2 LEDs														1
7L	7 LEDs														2
Position measuring range															
20	20 mm														1
40	40 mm														1
	20 ... 220 mm														2

- 1 Only with switching output PU
 2 Only with switching output PP

Ordering – Product options

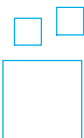

Configurable product

This product and all its options can be ordered using the configurator.

The configurator can be found under Products on the DVD or
 → www.festo.com/catalogue/...

Enter the type code in the search field.

Accessories

Round design

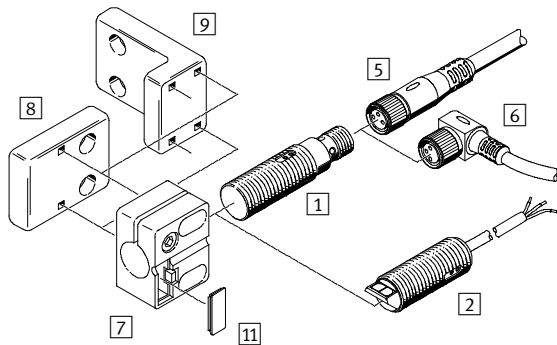



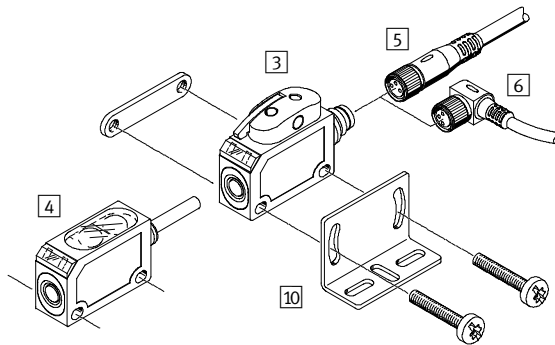

Block design











Mounting components and accessories	→ Page/ online
Sensors	
1 Round design, Ø 4 mm, M12, M18, with plug	772
2 Same, with cable	772
3 Block design, with plug	774, 776
4 Block design, with cable	774, 776
Connecting cables	
5 NEBU-M...G..., straight version	758
SIM-M...G..., straight version	nebu
6 NEBU-M...W..., angled version	758
SIM-M...W..., angled version	nebu
Sensor brackets	
7 SIEZ-NB	787
8 SIEZ-UV	787
9 SIEZ-UH	787
Mounting brackets	
10 SOEZ-HW-Q20	787
SOEZ-HW-Q30	787
SOEZ-HW-Q50	787

Mounting components and accessories	→ Page/ online
Inscription label	
11 SIEZ-LB	787
Fibre-optic cables, polymer	
- SOEZ-LLK-RT, diffuse sensor	787
SOEZ-LLK-SE, through-beam sensor	787
Fibre-optic cables, glass fibre	
- SOEZ-LLG-RT, diffuse sensor	787
SOEZ-LLG-SE, through-beam sensor	787
Reflectors	
- Reflector	787
Reflector foil	787
Reflector for laser light	787



Accessories – Ordering data

	Cable length [m]		Part No.	Type
Connecting cable				
5/6 M8x1 Technical data → 949				
	2.5	★	541333	NEBU-M8G3-K-2.5-LE3
	5	★	541334	NEBU-M8G3-K-5-LE3
	2.5	★	541338	NEBU-M8W3-K-2.5-LE3
	5	★	541341	NEBU-M8W3-K-5-LE3
5/6 M12x1 Technical data → 949				
	2.5		541363	NEBU-M12G5-K-2.5-LE3
	5		541364	NEBU-M12G5-K-5-LE3
	2.5		541367	NEBU-M12W5-K-2.5-LE3
	5		541370	NEBU-M12W5-K-5-LE3

	For design	Part No.	Type
7/8/9 Sensor bracket			
	4	538343	SIEZ-NB-4
	M12	538347	SIEZ-NB-12
	M18, M18W	538349	SIEZ-NB-18
	M12	538354	SIEZ-UH
	M18, M18W		
	M12	538355	SIEZ-UV
	M18, M18W		
10 Mounting bracket			
	Q20	537785	SOEZ-HW-Q20
	Q30	165355	SOEZ-HW-Q30
	Q50	537786	SOEZ-HW-Q50

	For design	Part No.	Type
11 Inscription label			
	M12, M18, M18W, M30	538353	SIEZ-LB
Fibre-optic cable, polymer			
	RT ¹⁾	165358	SOEZ-LLK-RT-2,0-M6
	S/E ²⁾	165360	SOEZ-LLK-SE-2,0-M4
Fibre-optic cable, glass fibre			
	RT ¹⁾	165356	SOEZ-LLG-RT-0,5-M6
	S/E ²⁾	165357	SOEZ-LLG-SE-0,5-M4
Fibre-optic cutter			
	For polymer fibre-optic cables	36479	SOE-LKS



- 1) Diffuse sensor
2) Through-beam sensor

	Size [mm]	Part No.	Type
Reflector			
	∅ 20	165363	SOEZ-RFS-20
	∅ 40	165364	SOEZ-RFS-40
	∅ 80	165365	SOEZ-RFS-80
Reflector foil			
	100x100	165362	SOEZ-RFF-100
Reflector for laser light			
	10x50	537787	SOEZ-RFL10
	50x50	537788	SOEZ-RFL50

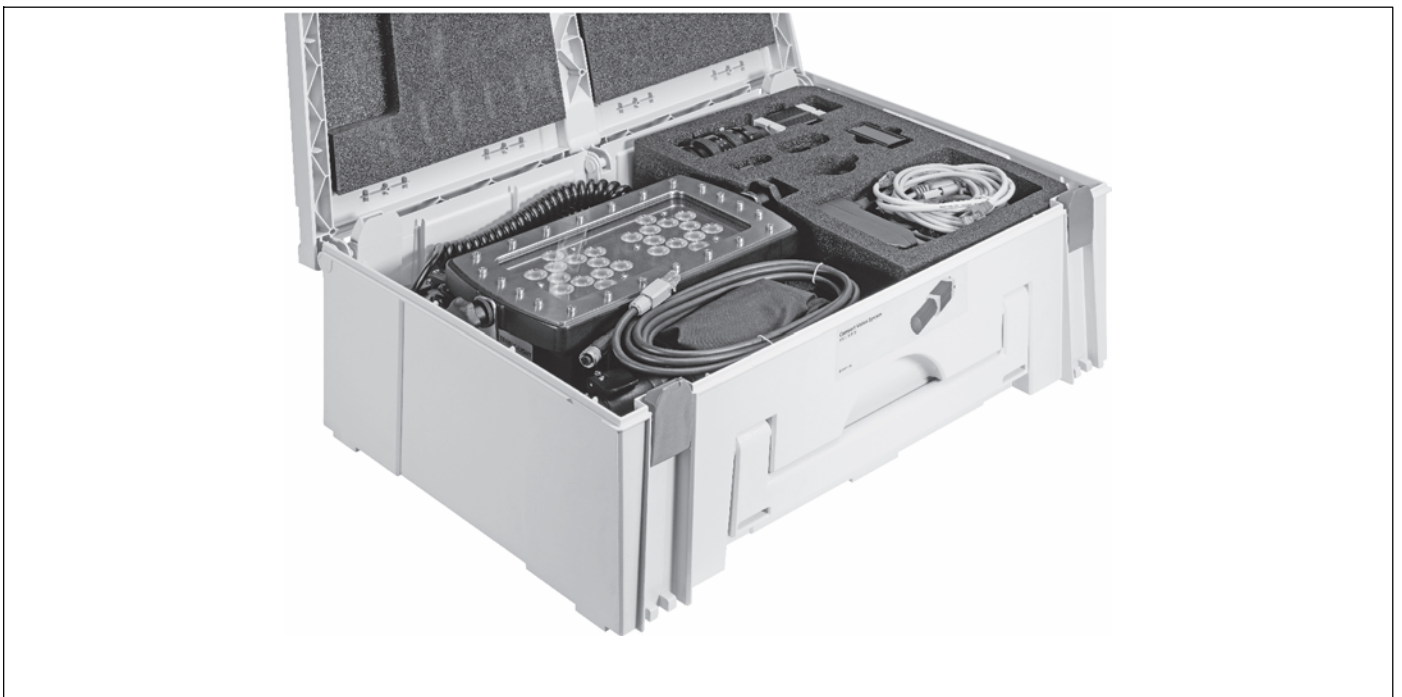



11 Compact vision systems



Function monitoring

		
Type	Compact vision system SBOA-M	Compact vision system SBOC-M
Sensor resolution	640 x 480 pixels (VGA)	640 x 480 pixels (VGA)
Working distance	Depends on the lens chosen	Depends on the lens chosen
Field of vision	Depends on the lens chosen	Depends on the lens chosen
Frame rate (full image)	27 ... 241 fps	27 ... 241 fps
Exposure time	1 ... 1,000,000 µs	1 ... 1,000,000 µs
Description	<ul style="list-style-type: none"> Systainer with compact vision system SBOC-M and accessories 	<ul style="list-style-type: none"> High-speed camera for diagnostics and commissioning as well as for function monitoring of fast motion sequences Recording and storage electronics integrated in the camera For standard lens with C mount connection Can be networked via Ethernet Compact dimensions, low weight
→ Page/online	sbox	sbox

Orientation and quality inspection

				
Type	Compact vision system SBOC-Q	Compact vision system SBOI-Q	Checkbox Compact CHB-C	Checkbox CHB
Sensor resolution	1280 x 1024 pixels (SXGA) , 640 x 480 pixels (VGA), 752 x 480 pixels (WideVGA)	640 x 480 pixels (VGA), 752 x 480 pixels (WideVGA)	512 pixels, 1024 pixels	1024 pixels/line, 512 pixels/line
Max. no. of inspection programs	256	256	16	48
Frame rate (full image)	27 ... 150 fps	60 ... 150 fps		
Lens mounting	CS mount (C mount with lens protection tube)	Integrated lens		
Min. part length			1 mm	3 mm
Min. part diameter			0.5 mm	0.5 mm
Description	<ul style="list-style-type: none"> Intelligent field-based camera For 2D quality inspection, position and rotary orientation sensing, reading of 1D and 2D codes, reading of optical characters (OCR) Integrated full PLC (CoDeSys) Ethernet and CAN for communicating with higher-order controllers 	<ul style="list-style-type: none"> Intelligent field-based camera For 2D quality inspection, position and rotary orientation sensing, reading of 1D and 2D codes, reading of optical characters (OCR) Integrated full PLC (CoDeSys) Ethernet and CAN for communicating with higher-order controllers 	<ul style="list-style-type: none"> Intelligent line-scan camera For orientation recognition and quality inspection of small moving parts Encoder connection Teach-in function 	<ul style="list-style-type: none"> Intelligent, line-scan camera-based image processing system For orientation recognition and quality inspection of small moving parts Available with conveyor unit and air ejector positions Available with encoder connection Teach-in function
→ Page/online	sbox	sbox	chb-c	chb-c

12 Compressed air preparation

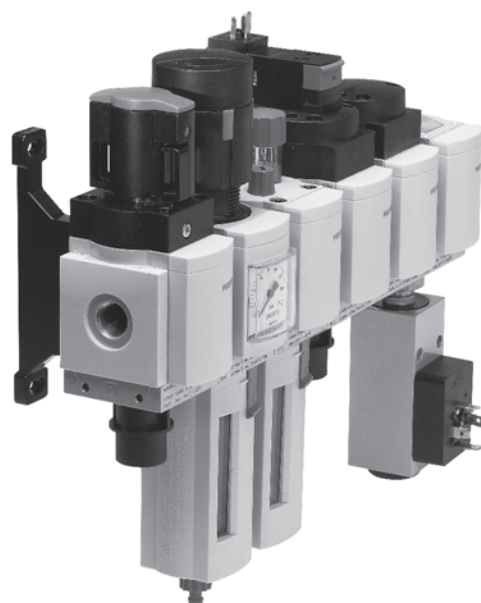

Software tool

<p>Air consumption</p>		<p>Calculate your system's air consumption quickly and conveniently. Simply enter all the drives and tubing, set the cycle times and working pressure and the air consumption per minute and per day will be calculated for you. It includes a feature for exporting the input table together with the result directly to Excel.</p>	<p>This tool can be found</p> <ul style="list-style-type: none"> • in the electronic catalogue via the blue icons in the product tree underneath the search field, or • on the website under Support in the Engineering software area, or • on the DVD under Selection and sizing.
<p>Configurator</p>		<p>Design a product with numerous features reliably and quickly with the help of the configurator. Select all the required product features step-by-step. The use of logic checks ensures that only correct configurations are available for selection. A dynamic graphic generated on the basis of the configuration provides visual assistance in selecting the correct product features.</p>	<p>The configurator is part of the electronic catalogue and is not available as a separate software program.</p>

Service unit combinations: D series, metal

<p>Type</p>	<p>Service unit combination with lubricator FRC-K</p>	<p>Service unit combination without lubricator LFR-K, LFRS-K</p>
<p>Pneumatic connection 1</p>	<p>G1/8, G1/4, G3/8, G1/2, G3/4</p>	<p>G1/8, G1/4, G3/8, G1/2, G3/4</p>
<p>Standard nominal flow rate</p>	<p>530 ... 8,200 l/min</p>	<p>575 ... 9,400 l/min</p>
<p>Pressure regulation range</p>	<p>0.5 ... 12 bar</p>	<p>0.5 ... 12 bar</p>
<p>Operating pressure</p>	<p>1 ... 16 bar</p>	<p>1 ... 16 bar</p>
<p>Grade of filtration</p>	<p>40 µm</p>	<p>40 µm</p>
<p>Description</p>	<ul style="list-style-type: none"> • Combination of filter regulator LFR, branching module FRM, lubricator LOE, on-off valve HE, HEE, soft-start valve HEL, mounting accessories • Sizes: mini, midi, maxi 	<ul style="list-style-type: none"> • Combination of filter regulator LFR, LFRS, branching module FRM, on-off valve HE, HEE, soft-start valve HEL, mounting accessories • Sizes: mini, midi, maxi
<p>→ Page/online</p>	<p>frc</p>	<p>lfr</p>

12

Service unit combinations: D series, polymer

<p>Type</p>	<p>Service unit combination FRC-DB</p>	<p>Service unit combination LFR-DB</p>
<p>Pneumatic connection 1</p>	<p>G1/4</p>	<p>G1/4</p>
<p>Standard nominal flow rate</p>	<p>400 ... 700 l/min</p>	<p>1,900 l/min</p>
<p>Pressure regulation range</p>	<p>0.5 ... 7 bar</p>	<p>0.5 ... 7 bar</p>
<p>Operating pressure</p>	<p>1.5 ... 10 bar</p>	<p>1.5 ... 10 bar</p>
<p>Grade of filtration</p>	<p>40 µm</p>	<p>40 µm</p>
<p>Description</p>	<ul style="list-style-type: none"> • Combination of on-off valve, filter regulator, distributor module and lubricator • Size: mini 	<ul style="list-style-type: none"> • Combination of on-off valve, filter regulator and distributor module • Size: mini
<p>→ Page/online</p>	<p>frc</p>	<p>lfr</p>

Service unit combinations: MS series

	
Type	Service unit combination MSB4, MSB6, MSB9
Pneumatic connection 1	G1/8, G1/4, G1/2, G3/4, G1, G11/4, G11/2
Standard nominal flow rate	550 ... 18,000 l/min
Pressure regulation range	0.5 ... 16 bar
Operating pressure	0 ... 20 bar
Grade of filtration	0.01 ... 40 µm
Description	<ul style="list-style-type: none"> Sizes: 4, 6, 9 Combination of filter regulator MS-LFR, filter MS-LF, fine and micro filter MS-LFM, activated carbon filter MS-LFX, pressure regulator MS-LR, MS-LRB, precision pressure regulator MS-LRP, MS-LRPB, electrical pressure regulator MS-LRE, lubricator MS-LOE, on-off valve MS-EM, MS-EE, soft-start valve MS-DL, MS-DE, soft-start/quick exhaust valve MS-SV, membrane air dryer MS-LDM1
→ Page/online	814

Filter regulators/lubricators: D series, metal

	
Type	Service unit FRC, FRCS
Pneumatic connection 1	G1/8, G1/4, G3/8, G1/2, G3/4, G1, M5, M7, QS-4, QS-6
Standard nominal flow rate	80 ... 8,700 l/min
Pressure regulation range	0.5 ... 12 bar
Operating pressure	1 ... 16 bar
Grade of filtration	5 ... 40 µm
Description	<ul style="list-style-type: none"> Filter, regulator and lubricator functions in a single unit High flow rate and highly efficient in removing contaminants Good regulation characteristics with minimal pressure hysteresis Setting values are secured by locking the rotary knob Sizes: micro, mini, midi, maxi Grid dimension 25, 40, 55, 66 mm
→ Page/online	frc

Filter regulators/lubricators: D series, polymer

	
Type	Service unit FRC-DB
Pneumatic connection 1	G1/8, G1/4
Standard nominal flow rate	400 ... 650 l/min
Pressure regulation range	0.5 ... 7 bar
Operating pressure	1.5 ... 10 bar
Grade of filtration	5 ... 40 µm
Description	<ul style="list-style-type: none"> Filter, regulator and lubricator functions in a single unit High flow rate and highly efficient in removing contaminants Good regulation characteristics with minimal pressure hysteresis Setting values are secured by means of the rotary knob with detent With manual or semi-automatic condensate drain Size: mini
→ Page/online	frc

Filter regulators/lubricators: MS series

	
Type	Service unit MSB4-FRC, MSB6-FRC
Pneumatic connection 1	G1/8, G1/4, G3/8, G1/2
Standard nominal flow rate	800 ... 4,800 l/min
Pressure regulation range	0.3 ... 12 bar
Operating pressure	1.5 ... 20 bar
Grade of filtration	5 ... 40 µm
Description	<ul style="list-style-type: none"> • Sizes: 4, 6 • Filter, regulator and lubricator functions in a single unit • High flow rate and highly efficient in removing contaminants • Good regulation characteristics with minimal pressure hysteresis • Setting values are secured by locking the rotary knob
→ Page/online	825

Filter regulators: D series, metal

	
Type	Filter regulator LFR, LFRS
Pneumatic connection 1	G1/8, G1/4, G3/8, G1/2, G3/4, G1, M5, M7, QS-4, QS-6
Standard nominal flow rate	110 ... 11,000 l/min
Pressure regulation range	0.5 ... 12 bar
Operating pressure	1... 16 bar
Grade of filtration	5 ... 40 µm
Description	<ul style="list-style-type: none"> • Space-saving design with filter and regulator in a single unit • Good particle separation and high flow rate • Good regulation characteristics with minimal hysteresis • Two pressure gauge connections for flexible installation • Setting values are secured by locking the rotary knob • With manual, semi-automatic or fully automatic condensate drain • Lockable rotary knob
→ Page/online	lfr





12 Filter regulators: D series, polymer

	
Type	Filter regulator LFR-DB
Pneumatic connection 1	G1/8, G1/4
Standard nominal flow rate	500 ... 1,200 l/min
Pressure regulation range	0.5 ... 7 bar
Operating pressure	1.5... 10 bar
Grade of filtration	5 ... 40 µm
Description	<ul style="list-style-type: none"> • Space-saving design with filter and regulator in a single unit • Good particle separation and high flow rate • Good regulation characteristics with minimal hysteresis • With manual or semi-automatic condensate drain • Setting values are secured by locking the rotary knob
→ Page/online	lfr

Filter regulators: MS series

	
Type	Filter regulator MS4-LFR, MS6-LFR, MS9-LFR, MS12-LFR
Pneumatic connection 1	Connecting plate, G1/8, G1/4, G3/8, G1/2, G3/4, G1
Standard nominal flow rate	850 ... 23,000 l/min
Pressure regulation range	0.3 ... 16 bar
Operating pressure	0.8 ... 20 bar
Grade of filtration	5 ... 40 µm
Description	<ul style="list-style-type: none"> • Good regulation characteristics with minimal hysteresis and primary pressure compensation • Good particle and condensate separation • Available with or without secondary venting • High flow rate • MS4-LFR, MS6-LFR: directly actuated diaphragm regulator, MS9-LFR: piloted or directly actuated filter-diaphragm regulator, MS12-LFR: piloted diaphragm regulator without internal air consumption • Lockable rotary knob • Return flow option for exhausting from output 2 to output 1 already integrated
→ Page/online	828





Filters: D series, metal

				
Type	Filter LF	Fine filter LFMB	Micro filter LFMA	Fine filter combination LFMBA
Pneumatic connection 1	Connecting plate, G1/8, G1/4, G3/8, G1/2, G3/4, G1, M5, M7, QS-4, QS-6	Connecting plate, G1/8, G1/4, G3/8, G1/2, G3/4, G1	Connecting plate, G1/8, G1/4, G3/8, G1/2, G3/4, G1	G1/8, G1/4, G3/8, G1/2, G3/4, G1
Standard nominal flow rate	170 ... 5,300 l/min	250 ... 1,250 l/min	130 ... 950 l/min	125 ... 600 l/min
Operating pressure	0 ... 16 bar	1 ... 16 bar	1 ... 16 bar	1 ... 16 bar
Grade of filtration	5 ... 40 µm	1 µm	0.01 µm	0.01 µm
Description	<ul style="list-style-type: none"> • Good particle and condensate separation • High flow rate with minimal pressure drop • With manual or fully automatic condensate drain 	<ul style="list-style-type: none"> • High-efficiency filter for special requirements • Air quality to ISO 8573-1 • Version with differential pressure indicator for visual indication of filter contamination 	<ul style="list-style-type: none"> • High-efficiency filter for special requirements • Air quality to ISO 8573-1 • Version with differential pressure indicator for visual indication of filter contamination 	<ul style="list-style-type: none"> • High-efficiency filter for special requirements • Air quality to ISO 8573-1 • Available as pre-assembled filter combination • Version with differential pressure indicator for visual indication of filter contamination
→ Page/online	lf	lfmb	lfma	lfmba

Filters: D series, metal

	
Type	Activated carbon filter LFX
Pneumatic connection 1	Connecting plate, G1/8, G1/4, G3/8, G1/2, G3/4, G1
Standard nominal flow rate	300 ... 1,430 l/min
Operating pressure	0 ... 16 bar
Grade of filtration	
Description	<ul style="list-style-type: none"> • Removal of liquid and gaseous oil particles from compressed air using activated carbon • Activated carbon filter cartridges provide odour and oil-free air to food industry standard • Residual oil content ≤0.003 mg/m³ • Air quality class at the output 1.7.1 to ISO 8573-1
→ Page/online	lfx



Filters: MS series

Type	 Filter MS4-LF, MS6-LF, MS9-LF, MS12-LF	 Fine filter MS4-LFM-B, MS6-LFM-B, MS9-LFM-B, MS12-LFM-B	 Micro filter MS4-LFM-A, MS6-LFM-A, MS9-LFM-A, MS12-LFM-A	 Activated carbon filter MS4-LFX, MS6-LFX, MS9-LFX, MS12-LFX
Pneumatic connection 1	Connecting plate, G1/8, G1/4, G3/8, G1/2, G3/4, G1	Connecting plate, G1/8, G1/4, G3/8, G1/2, G3/4, G1	Connecting plate, G1/8, G1/4, G3/8, G1/2, G3/4, G1	Connecting plate, G1/8, G1/4, G3/8, G1/2, G3/4, G1
Standard nominal flow rate	1,000 ... 16,000 l/min	120 ... 7,600 l/min	120 ... 7,000 l/min	250 ... 6,000 l/min
Operating pressure	0 ... 20 bar	0 ... 20 bar	0 ... 20 bar	0 ... 20 bar
Grade of filtration	5 ... 40 µm	1 µm	0.01 µm	
Description	<ul style="list-style-type: none"> • Good particle and condensate separation • High flow rate with minimal pressure drop • Available with manual, semi-automatic, fully automatic or fully automatic, electrically actuated condensate drain 	<ul style="list-style-type: none"> • High-efficiency filter for exceptionally clean compressed air • Air quality to ISO 8573-1 • Available with differential pressure indicator for indication of contamination • Available with electronic filter pollution indicator 	<ul style="list-style-type: none"> • High-efficiency filter for exceptionally clean compressed air • Air quality to ISO 8573-1 • Available with differential pressure indicator for indication of contamination • Available with electronic filter pollution indicator 	<ul style="list-style-type: none"> • Removal of liquid and gaseous oil particles from compressed air using activated carbon • Eliminates odours and vapours
→ Page/online	ms4-lf	ms4-lfm-b	ms4-lfm-a	ms4-lfx



Filters: Individual devices

Type	 Filter silencer LFU
Size	G1/4, G3/8, G1/2, G1
Grade of filtration	1 µm
Operating pressure	0 ... 16 bar
Flow rate with respect to atmosphere	4,000 ... 12,500 l/min
Noise reduction	Reduction by 40 dB
Description	<ul style="list-style-type: none"> • Removes up to 99.99% of oil and other contaminants from exhaust air • Manual rotary condensate drain • Exhaust noise reduced regardless of frequency
→ Page/online	lfu



Regulators: D series, metal

Type	 Pressure regulator LR, LRS	 Pressure regulator LRB, LRBS	 Pressure regulator combination LRB-K
Pneumatic connection 1	G1/8, G1/4, G3/8, G1/2, G3/4, G1, M5, M7, QS-4, QS-6	Connecting plate	G1/4, G3/8, G1/2
Standard nominal flow rate	120 ... 12,500 l/min	1,600 ... 3,800 l/min	1,000 ... 3,800 l/min
Pressure regulation range	0.5 ... 12 bar	0.5 ... 12 bar	0.5 ... 12 bar
Operating pressure	0 ... 20 bar	1 ... 16 bar	1 ... 16 bar
Max. pressure hysteresis	0.2 ... 0.5 bar	0.2 bar	0.2 ... 0.5 bar
Description	<ul style="list-style-type: none"> • Suitable for front panel mounting • Lockable design • Two pressure gauge connections for different fitting options • Mini, midi size: directly actuated diaphragm regulator • Maxi size: piloted piston regulator, diaphragm regulator LRS-DI • Good regulation characteristics with minimal pressure hysteresis • High flow rate • Return flow option for venting from output 2 to input 1 • Available with pressure gauge • Sizes: micro, mini, midi, maxi 	<ul style="list-style-type: none"> • Manifold assembly with through air supply • Lockable design • Good regulation characteristics with minimal hysteresis and primary pressure compensation • For configuring a regulator manifold with independent pressure ranges • Settings secured via detent on rotary knob and push-in adjustment lock • Directly actuated diaphragm regulator • Without pressure gauge • Sizes: mini, midi 	<ul style="list-style-type: none"> • With through air supply • Regulator manifold with independent pressure ranges • Good regulation characteristics with minimal hysteresis and primary pressure compensation • Settings secured via detent on rotary knob and push-in adjustment lock • Directly actuated diaphragm regulator • Without pressure gauge • Sizes: mini, midi
→ Page/online	lr	lrb	lrb



Regulators: D series, polymer

Type	 Pressure regulator LR-DB	 Pressure regulator combination LRB-DB
Pneumatic connection 1	G1/8, G1/4	G1/2
Standard nominal flow rate	≥1,300 l/min	≥1,000 l/min
Pressure regulation range	0.5 ... 7 bar	0.5 ... 7 bar
Operating pressure	1.5 ... 10 bar	0 ... 16 bar
Max. pressure hysteresis	0.5 bar	0.5 bar
Description	<ul style="list-style-type: none"> • High flow rate • Good regulation characteristics with minimal pressure hysteresis • Setting values are secured by locking the rotary knob • Available with pressure gauge • Size: mini 	<ul style="list-style-type: none"> • With through air supply • Good regulation characteristics with minimal hysteresis and primary pressure compensation • Regulator manifold with independent pressure ranges • Setting values are secured by locking the rotary knob • Without pressure gauge • Size: mini
→ Page/online	lr-db	lrb-db



Regulators: MS series

Type	 Pressure regulator MS4-LR, MS6-LR, MS9-LR	 Pressure regulator MS12-LR	 Pressure regulator MS4-LRB, MS6-LRB
Pneumatic connection 1	Connecting plate, G1/8, G1/4, G3/8, G1/2, G3/4, G1	Connecting plate	Connecting plate, G1/4, G3/8, G1/2
Standard nominal flow rate	1,000 ... 33,000 l/min	12,000 ... 22,000 l/min	300 ... 7,300 l/min
Pressure regulation range	0.3 ... 16 bar	0.15 ... 16 bar	0.3 ... 16 bar
Operating pressure	0.8 ... 20 bar	0.8 ... 21 bar	0.8 ... 20 bar
Max. pressure hysteresis	0.25 ... 0.4 bar	0.04 ... 0.4 bar	0.25 bar
Description	<ul style="list-style-type: none"> • Good regulation characteristics with minimal hysteresis and primary pressure compensation • High flow rate with minimal pressure drop • Available with secondary venting • Lockable rotary knob • With pressure sensor with display and rotary knob pressure gauge • Sizes: 4, 6, 9 • Grid dimension 40, 62, 90 mm 	<ul style="list-style-type: none"> • Good regulation characteristics with minimal hysteresis and primary pressure compensation • High flow rate with minimal pressure drop • Actuator lock to protect set values against adjustment • With secondary venting • Pressure gauge connection for different fitting options • Size: 12 • Grid dimension 124 mm • MS12-LR...-PO: pneumatically actuated (pressure range determined by means of pilot regulator) • MS12-LR...-PE6: electrically actuated (pilot control by proportional pressure regulator) 	<ul style="list-style-type: none"> • For manifold assembly with through air supply • For configuring a regulator manifold with independent pressure regulation ranges • Good regulation characteristics with minimal hysteresis and primary pressure compensation • Actuator lock to protect set values against adjustment • With and without secondary venting • Integrated return flow option for exhausting from output 2 to output 1 • Optional pressure sensor • Optional rotary knob pressure gauge
→ Page/online	839	839	849

Regulators: MS series

Type	 Precision pressure regulator MS6-LRP, MS6-LRPB	 Electrical pressure regulator MS6-LRE
Pneumatic connection 1	Connecting plate, G1/4, G3/8, G1/2	Connecting plate, G1/4, G3/8, G1/2
Standard nominal flow rate	800 ... 5,000 l/min	2,200 ... 7,500 l/min
Pressure regulation range	0.05 ... 12 bar	0.3 ... 16 bar
Operating pressure	1 ... 14 bar	0.8 ... 20 bar
Max. pressure hysteresis	0.02 bar	0.25 bar
Description	<ul style="list-style-type: none"> • As individual device and for manifold assembly • Manifold assembly with through air supply • Good regulation characteristics with minimal hysteresis and primary pressure compensation • Actuator lock to protect set values against adjustment • Available with pressure sensor with display • Size: 6 • Grid dimension 62 mm 	<ul style="list-style-type: none"> • With integrated electric drive unit for indirectly setting the output pressure • Constant output pressure even in the event of a power failure thanks to the fail-safe function • Available with control unit with display • Available with integrated pressure sensor with electrical output • With or without secondary venting • Size: 6 • Grid dimension 62 mm
→ Page/online	ms6-lrp	ms6-lre

Regulators: Individual devices

		
Type	Pressure regulator LR-G, LRS-G	Precision pressure regulator LRP, LRPS
Pneumatic connection 1	G1/8	G1/4
Standard nominal flow rate	600 ... 700 l/min	800 ... 2,300 l/min
Pressure regulation range	0.5 ... 12 bar	0.05 ... 10 bar
Operating pressure	1 ... 20 bar	1 ... 12 bar
Max. pressure hysteresis	0.2 bar	0.02 bar
Description	<ul style="list-style-type: none"> • Lockable design • Sturdy design • For front panel mounting • Excellent flow rates • Precision diaphragm regulator 	<ul style="list-style-type: none"> • Lockable design • Precision pressure adjustment possible both in static and dynamic applications • Good response characteristics during rapid modification of supply pressure and flow rate • Supply pressure fluctuations are almost entirely compensated
→ Page/online	lr-g	lrp





Lubricators: D series

	
Type	Lubricator LOE
Pneumatic connection 1	G1/8, G1/4, G3/8, G1/2, G3/4, G1, M5, M7, QS-4, QS-6
Standard nominal flow rate	160 ... 9,000 l/min
Operating pressure	0 ... 16 bar
Minimum flow rate for lubricator function	3 ... 10 l/min
Description	<ul style="list-style-type: none"> • Proportional lubricator with precision oil metering • Quick and easy top-up even under pressure • High flow rate • Sturdy metal housing and transparent lubricator bowl with metal bowl guard • Oil capacity 6.5 ... 190 cm³ • Sizes: micro, mini, midi, maxi • Grid dimension 25, 40, 55, 66 mm
→ Page/online	loe





Lubricators: MS series

	
Type	Lubricator MS4-LOE, MS6-LOE, MS9-LOE, MS12-LOE
Pneumatic connection 1	Connecting plate, G1/8, G1/4, G3/8, G1/2, G3/4, G1
Standard nominal flow rate	1,100 ... 27,000 l/min
Operating pressure	1 ... 16 bar
Minimum flow rate for lubricator function	40 ... 400 l/min
Description	<ul style="list-style-type: none"> • Configurable proportional lubricator with precision oil metering • Quick and easy oil top-up even under pressure • Choice of flow direction: left-right, right-left • Oil capacity 30 ... 1,500 cm³ • Sizes: 4, 6, 9, 12 • Grid dimension 40, 60, 90, 124 mm
→ Page/online	ms4-loe



On-off and soft-start valves: D series

Type	 On-off valve HE	 On-off valve HEE	 On-off valve HEP	 Soft-start valve HEL
Pneumatic connection 1	G1/8, G1/4, G3/8, G1/2, G3/4, G1	G1/8, G1/4, G3/8, G1/2, G3/4, G1	G1/8, G1/4, G3/8, G1/2, G3/4, G1	G1/8, G1/4, G3/8, G1/2, G3/4, G1
Standard nominal flow rate	1,000 ... 10,000 l/min	1,000 ... 6,500 l/min	1,000 ... 6,500 l/min	1,000 ... 6,500 l/min
Operating pressure	0 ... 16 bar	2.5 ... 16 bar	0 ... 16 bar	3 ... 16 bar
Actuation type	Manual	Electric	Pneumatic	Pneumatic
Description	<ul style="list-style-type: none"> • 3/2-way valve • Ducted exhaust air possible via a threaded connection • The switching position is immediately recognisable • Sizes: mini, midi, maxi • Grid dimension 40, 55, 66 mm 	<ul style="list-style-type: none"> • For pressurising and venting pneumatic installations • With solenoid coil, without plug socket • Solenoid head can be repositioned by 4 x 90° • Detenting and non-detenting manual override • Supply voltage 24 V DC, 110, 230 V AC • Sizes: mini, midi, maxi • Grid dimension 40, 55, 66 mm 	<ul style="list-style-type: none"> • On-off valve for pressurising and venting pneumatic installations • As an individual device or in combination with other D series modules • Especially suitable for applications requiring explosion protection • Sizes: mini, midi, maxi • Grid dimension 40, 55, 66 mm 	<ul style="list-style-type: none"> • For gradual pressure build-up (for use with on-off valves HE and HEE) • For advancing drives slowly and reliably into the initial position • For avoiding sudden and unexpected movements • Adjustable switching time delay • Sizes: mini, midi, maxi • Grid dimension 40, 55, 66 mm
→ Page/online	he	hee	hep	hel



On-off and soft-start valves: MS series

Type	 On-off valve MS4-EM1, MS6-EM1, MS9-EM, MS12-EM	 On-off valve MS4-EE, MS6-EE, MS9-EE, MS12-EE	 Soft-start valve MS4-DL, MS6-DL, MS12-DL	 Soft-start valve MS4-DE, MS6-DE, MS12-DE
Pneumatic connection 1	Connecting plate, G1/8, G1/4, G3/8, G1/2, G3/4, G1	Connecting plate, G1/8, G1/4, G3/8, G1/2, G3/4, G1	Connecting plate, G1/8, G1/4, G3/8, G1/2, G3/4, G1	Connecting plate, G1/8, G1/4, G3/8, G1/2, G3/4, G1
Standard nominal flow rate	1,200 ... 32,000 l/min	1,000 ... 32,000 l/min	1,000 ... 42,000 l/min	1,000 ... 42,000 l/min
Operating pressure	0 ... 20 bar	3 ... 18 bar	2 ... 20 bar	3 ... 18 bar
Actuation type	Manual	Electric	Pneumatic	Electric
Description	<ul style="list-style-type: none"> • A silencer can be attached or the exhaust air ducted at port 3 • Available with pressure gauge and pressure sensor with display • Sizes: 4, 6, 9, 12 • Grid dimension 40, 62, 90, 124 mm 	<ul style="list-style-type: none"> • Supply voltage 24 V DC, 110, 230 V AC • Available with pressure sensor with display • With solenoid coil, without plug socket • Sizes: 4, 6, 9, 12 • Grid dimension 40, 62, 90, 124 mm 	<ul style="list-style-type: none"> • For slowly pressurising and venting pneumatic installations (for use with on-off valves EM1 and EE) • For advancing the drives slowly and reliably into the initial position • For avoiding sudden and unexpected movements • Adjustable switching time delay • Sizes: 4, 6, 12 • Grid dimension 40, 62, 124 mm 	<ul style="list-style-type: none"> • Supply voltage 24 V DC, 110, 230 V AC • For slowly pressurising and venting pneumatic installations • For advancing the drives slowly and reliably into the initial position • For avoiding sudden and unexpected movements • Adjustable switching time delay • Sizes: 4, 6, 12 • Grid dimension 40, 62, 124 mm
→ Page/online	855	862	870	ms4-de

On-off and soft-start valves: MS series

		
Type	Soft-start/quick exhaust valve MS6-SV-E	Soft-start/quick exhaust valve MS6-SV-C, MS9-SV-C
Pneumatic connection 1	Connecting plate, G1/2	Connecting plate, G1/2, G3/4, G1
Standard nominal flow rate	4,300 l/min	5,700 l/min, 14,150 ... 16,460 l/min
Operating pressure	3.5 ... 10 bar	3 ... 18 bar, 3.5 ... 16 bar
Actuation type	Electric	Electric
Description	<ul style="list-style-type: none"> • Performance Level: category 4, 2-channel with self-monitoring, to EN ISO 13849-1 • SIL 3 • For reducing pressure quickly and reliably and for building up pressure gradually • Switching time delay adjustable via a flow control valve for gradual pressure build-up • Available with silencer • Supply voltage 24 V DC • Size: 6 • Grid dimension 62 mm 	<ul style="list-style-type: none"> • Performance Level: category 1, to EN ISO 13849-1 • For reducing pressure quickly and reliably and for building up pressure gradually • Switching time delay adjustable via a flow control valve for gradual pressure build-up • Supply voltage 24 V DC • Size: 6, 9 • Grid dimension 62, 90 mm
→ Page/online	ms6-sv-e	875

On-off and soft-start valves: Individual devices

		
Type	Shut-off valve HE-LO	Solenoid valve, pneumatic valve MFHE, VLHE
Pneumatic connection 1	G3/8, G1/2, G3/4, G1	G1/4, G3/8, G1/2
Standard nominal flow rate	15,000 ... 10,000 l/min	1,200 ... 2,900 l/min
Operating pressure	1 ... 10 bar	2 ... 12 bar
Actuation type	Manual	Electric, pneumatic
Description	<ul style="list-style-type: none"> • To safety standard • For shutting off the compressed air supply whilst simultaneously exhausting systems powered by compressed air • Can be locked in the closed position • Screwed into piping, through-holes for wall mounting 	<ul style="list-style-type: none"> • For F solenoid coils • Piloted • On-off valve in combination with service units • Soft-start valve • Manual override, detenting
→ Page/online	he-lo	mfhe

Air dryers: D series

	
Type	Membrane air dryer LDM1
Pneumatic connection 1	G1/2, G3/4, G1
Standard nominal flow rate	300 ... 1,000 l/min
Operating pressure	3 ... 12.5 bar
Pressure dew point reduction	17 ... 20 K
Description	<ul style="list-style-type: none"> • Final dryer with excellent operational reliability • Flow rate-dependent dew point reduction • Wear-free function requiring no external energy • Size: maxi • Grid dimension 66 mm • Individual device with or without connecting plates, for service unit combination
→ Page/online	ldm1



Air dryers: MS series

	
Type	Membrane air dryer MS4-LDM1, MS6-LDM1
Pneumatic connection 1	Connecting plate, G1/8, G1/4, G3/8, G1/2
Standard nominal flow rate	50 ... 400 l/min
Operating pressure	3 ... 12.5 bar
Pressure dew point reduction	20 K
Description	<ul style="list-style-type: none"> • Final dryer with excellent operational reliability • Suitable for use as an individual device or for integration into existing service unit combinations • Flow rate-dependent dew point reduction • Wear-free function requiring no external energy • Sizes: 4, 6 • Grid dimension 40, 62 mm
→ Page/online	ms4-ldm1



Air dryers: Individual devices

	
Type	Adsorption dryer PDAD
Pneumatic connection 1	G3/8, G1/2
Standard nominal flow rate	10 ... 1,000 l/min
Supply pressure 1	4 ... 16 bar
Pressure dew point	-40 °C or -70 °C
Description	<ul style="list-style-type: none"> • Ideal for decentralised compressed air drying • Extends the service life of pneumatic components • Additional filtering of oil and particulates • Defined pressure dew point • High flow rate • Low purge air consumption and noise levels
→ Page/online	pdad



Compressed air distribution units: D series

		
Type	Branching module FRM	Distributor block FRZ
Pneumatic connection 1	G1/8, G1/4, G3/8, G1/2, G3/4, G1	Manifold module
Standard nominal flow rate in main flow direction 1->2	1,100 ... 20,000 l/min	
Operating pressure	0 ... 16 bar	
Description	<ul style="list-style-type: none"> • Designs with integrated non-return function, with pressure switch • Several additional air connections for greater flexibility • Can be used as an intermediate distributor for varying air qualities • Sizes: mini, midi, maxi • Grid dimension 40, 55, 66 mm 	<ul style="list-style-type: none"> • Sizes: micro, mini, midi, maxi • Grid dimension 25, 40, 55, 66 mm • Several additional air connections for greater flexibility
→ Page/online	frm	frz

Compressed air distribution units: MS series

		
Type	Branching module MS4-FRM, MS6-FRM, MS9-FRM, MS12-FRM	Distributor block MS4-FRM-FRZ, MS6-FRM-FRZ
Pneumatic connection 1	Connecting plate, G1/8, G1/4, G3/8, G1/2, G3/4, G1	G1/4, G1/2
Standard nominal flow rate in main flow direction 1->2	1,200 ... 50,000 l/min	4,050 ... 14,600 l/min
Operating pressure	0 ... 20 bar	0 ... 20 bar
Description	<ul style="list-style-type: none"> • Designs with integrated non-return function, with pressure switch • Pneumatic manifold with 4 connections • Can be used as an intermediate distributor for varying air qualities • Outlet at top and bottom • Available with pressure sensor with display • Sizes: 4, 6, 9, 12 • Grid dimension 40, 62, 90, 124 mm 	<ul style="list-style-type: none"> • Pneumatic manifold with 4 connections • Outlet at top and bottom • Can be used as an intermediate distributor for varying air qualities • Can be used as an intermediate distributor between two pressure regulators with large rotary knob with pressure gauge on size MS4 • Sizes: 4, 6 • Grid dimension 20, 31 mm
→ Page/online	882	ms4-frm

Condensate drains

			
Type	Water separator MS6-LWS, MS9-LWS, MS12-LWS	Condensate drain PWEA	Condensate drain WA
Pneumatic connection		G1/2	M9
Pneumatic connection 1	Connecting plate, G1/4, G3/8, G1/2, G3/4, G1		
Operating pressure	0.8 ... 16 bar	0.8 ... 16 bar	0 ... 16 bar
Description	<ul style="list-style-type: none"> • Maintenance-free • Constantly high condensate separation (99%) up to the maximum flow rate • Metal bowl • Available with fully automatic or fully automatic, electrically actuated condensate drain 	<ul style="list-style-type: none"> • Fully automatic condensate drain with independent electrical controller • Interface for communicating with master control device • Reliable thanks to non-contacting capacitive sensor • Can be used with service units or simply in piping systems • Ready status and switching status indicated via LEDs and electrical interface 	<ul style="list-style-type: none"> • For attachment to service units and compressed air networks/systems • Automatic emptying after the max. fill level has been reached • Automatic emptying after the operating pressure p < 0.5 bar is switched off • Manual actuation during operation is possible
→ Page/online	ms6-lws	pwea	wa

Pressure boosters



	
Type	Pressure booster DPA
Pneumatic connection 1	G1/4, G3/8, G1/2
Output pressure 2	4 ... 16 bar
Supply pressure 1	2 ... 10 bar
Description	<ul style="list-style-type: none"> Minimal loss of volume due to valve activation Designed as a pressure booster/air reservoir combination Any mounting position Short filling times Long service life Compact design Available with sensing option
→ Page/online	dpa

Pressure indicators

				
Type	Pressure gauge PAGN	Pressure gauge MA	Flanged pressure gauge FMA	Flanged precision pressure gauge, precision pressure gauge FMAP, MAP
Type of mounting	In-line installation	In-line installation	Front panel mounting	Front panel mounting, in-line installation
Display range	0 ... 16 bar	0 ... 25 bar	0 ... 16 bar	0 ... 16 bar
Pneumatic connection	QSP...10	G1/8, G1/4, M5, QS-4, QS-6, QS-8, R1/8, R1/4	G1/4	G1/4, R1/8
Operating pressure	0 ... 16 bar	0 ... 25 bar	0 ... 16 bar	0 ... 16 bar
Measurement accuracy class	2.5, 4	1.6, 2.5, 4, 5	1.6, 2.5	1, 1.6
Description	<ul style="list-style-type: none"> Display units bar, psi Pneumatic connection via QSP10 Mounting via retaining clamp 	<ul style="list-style-type: none"> Designs based on EN 837-1, optionally with red-green range Pneumatic connection via R, metric or G thread, push-in connector Display units bar, psi, MPa 	<ul style="list-style-type: none"> Design to DIN EN 837-1 Pneumatic connection via G thread Front panel mounting Display units bar, psi 	<ul style="list-style-type: none"> Conforms to EN 837-1 Display units bar, psi Connection via G or R thread
→ Page/online	pagn	ma	fma	fmap

12

Pressure indicators

		
Type	Pressure gauge kit DPA-MA-SET	Vacuum gauge VAM, FVAM
Type of mounting	Via male thread	Front panel mounting, screw-in
Display range		-1 bar, -1 ... 9 bar
Pneumatic connection	G1/8, G1/4, R1/8	G1/8, G1/4, R1/8, R1/4
Operating pressure	10 ... 16 bar	-1 bar, -1 ... 9 bar
Measurement accuracy class	2.5, 4	2.5
Description	<ul style="list-style-type: none"> For pressure booster DPA For monitoring the supply and output pressure Pneumatic connection via R, G thread 	<ul style="list-style-type: none"> Designs based on DIN EN 837-1, optionally with red-green range Pneumatic connection via R, G thread Screw-in or front panel mounting Double or single scale Display units bar, inHg, psi
→ Page/online	dpa	vam

Customised components – for your specific requirements



Components for compressed air preparation with customised designs

Can't find the compressed air preparation components you need in our catalogue?

We can offer you customised components that are tailored to your specific requirements – from minor product modifications to complete new product developments.

Common product modifications:

- Modified pressure range
- Rotary knob: in a special colour, with protection against rotation
- Fitting: integrated throttling port, special thread
- Tubing with special printing
- Pressure gauge with red-green range

Many additional variants are possible. Ask your Festo sales engineer, who will be happy to help. Further information on customised components can be found on your local website at www.festo.com







- Easy to assemble thanks to a modular structure
- 4 sizes (G $\frac{1}{8}$ to G2):
MS4 – grid dimension 40 mm, MS6 – grid dimension 62 mm,
MS9 – grid dimension 90 mm, MS12 – grid dimension 124 mm
- Compact with high flow rates: up to 22,000 l/min
- Integrated safety functions
- Broad range of functions: individual components, pre-assembled combinations ex-stock, application-specific combinations or complete turnkey solutions
- Selected types in accordance with the ATEX Directive for explosive atmospheres → www.festo.com/catalogue/ex
→ www.festo.com/catalogue/ms series

Key features

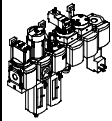
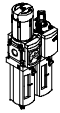
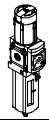
- Solutions for every application from individual components through pre-assembled combinations ex-stock and application-specific combinations to complete turnkey solutions
- Wealth of options ensures the right solution for every task
- Reliable compressed air supply thanks to ultra-modern functional modules with integrated sensors and remote adjustment function
- Maximum flow rates with minimum space requirement
- Flow rates up to 22,000 l/min with size MS12
- CAD models and configurator for easy selection of application-specific individual devices and MSB4, MSB6 and MSB9 combinations
→ www.festo.com/catalogue
- Simple connection system saves time when replacing individual modules without dismantling the entire unit
- Locking filter bowls and lockable valves fitted as standard for maximum control of the operating pressure offer maximum safety
- With soft-start valves, filter contamination indicator and fully automatic condensate drain for reliable operation of your system











Product range overview

Type	Size	Pneumatic connection in housing	Connecting plate	Pressure regulation range [bar]						Grade of filtration [µm]			
				0.05	0.05	0.1	0.3	0.1	0.5	0.01	1	5	40
Code			AG...	D2	D4	D5	D6	D7	D8	A	B	C	E
Service unit combinations (additional variants can be ordered using the configurator → online: msb4, msb6 or msb9)													
MSB 	4	G1/4	G1/8, G1/4, G3/8	-	-	-	■	■	-	-	-	■	■
	6	G1/2	G1/4, G3/8, G1/2, G3/4	-	-	-	■	■	-	-	-	■	■
	9	-	-	-	-	-	-	-	-	-	-	-	-
	12	-	-	-	-	-	-	-	-	-	-	-	-
Service units													
MSB-FRC 	4	G1/8, G1/4	G1/8, G1/4, G3/8	-	-	-	■	■	-	-	-	■	■
	6	G1/4, G3/8, G1/2	G1/4, G3/8, G1/2, G3/4	-	-	-	■	■	-	-	-	■	■
	9	-	-	-	-	-	-	-	-	-	-	-	-
	12	-	-	-	-	-	-	-	-	-	-	-	-
Individual devices													
Filter regulators MS-LFR 	4	G1/8, G1/4	G1/8, G1/4, G3/8	-	-	■	■	■	-	-	-	■	■
	6	G1/4, G3/8, G1/2	G1/4, G3/8, G1/2, G3/4	-	-	■	■	■	■	-	-	■	■
	9	G3/4, G1	G1/2, G3/4, G1, G1 1/4, G1 1/2	-	-	■	■	■	-	-	-	■	■
	12	-	G1, G1 1/4, G1 1/2, G2	-	-	■	■	■	-	-	-	■	■
Filters MS-LF 	4	G1/8, G1/4	G1/8, G1/4, G3/8	-	-	-	-	-	-	-	-	■	■
	6	G1/4, G3/8, G1/2	G1/4, G3/8, G1/2, G3/4	-	-	-	-	-	-	-	-	■	■
	9	G3/4, G1	G1/2, G3/4, G1, G1 1/4, G1 1/2	-	-	-	-	-	-	-	-	■	■
	12	-	G1, G1 1/4, G1 1/2, G2	-	-	-	-	-	-	-	-	■	■
Fine and micro filters MS-LFM 	4	G1/8, G1/4	G1/8, G1/4, G3/8	-	-	-	-	-	-	■	■	-	-
	6	G1/4, G3/8, G1/2	G1/4, G3/8, G1/2, G3/4	-	-	-	-	-	-	■	■	-	-
	9	G3/4, G1	G1/2, G3/4, G1, G1 1/4, G1 1/2	-	-	-	-	-	-	■	■	-	-
	12	-	G1, G1 1/4, G1 1/2, G2	-	-	-	-	-	-	■	■	-	-
Activated carbon filters MS-LFX 	4	G1/8, G1/4	G1/8, G1/4, G3/8	-	-	-	-	-	-	-	-	-	-
	6	G1/4, G3/8, G1/2	G1/4, G3/8, G1/2, G3/4	-	-	-	-	-	-	-	-	-	-
	9	G3/4, G1	G1/2, G3/4, G1, G1 1/4, G1 1/2	-	-	-	-	-	-	-	-	-	-
	12	-	G1, G1 1/4, G1 1/2, G2	-	-	-	-	-	-	-	-	-	-
Water separators MS-LWS 	4	-	-	-	-	-	-	-	-	-	-	-	-
	6	G1/4, G3/8, G1/2	G1/4, G3/8, G1/2, G3/4	-	-	-	-	-	-	-	-	-	-
	9	G3/4, G1	G1/2, G3/4, G1, G1 1/4, G1 1/2	-	-	-	-	-	-	-	-	-	-
	12	-	G1, G1 1/4, G1 1/2, G2	-	-	-	-	-	-	-	-	-	-

Product range overview

Type	Size	Bowl guard		Condensate drain				Pressure indicator				Security		Options		→ Page/ online	
		Plastic bowl guard	Metal bowl	Manual rotary	Semi-automatic	Fully automatic	External, fully automatic, electric	Cover plate (without pressure gauge)	Integrated MS pressure gauge	Adapter plate for EN pressure gauge G1/8	Adapter plate for EN pressure gauge G1/4	Pressure sensor	Rotary knob with detent, can be locked using accessories	Rotary knob with integrated lock	Silencer		Flow direction from right to left
Code		R	U	M	H	V	E...	VS	AG	A8	A4	AD...	AS	E11	S	Z	
Service unit combinations																	
MSB	4	■	■	■	-	■	-	-	■	-	-	-	■	-	-	■	814
	6	■	■	■	-	■	-	-	■	-	-	-	■	-	-	■	
	9	-	-	-	-	-	-	-	-	-	-	-	-	-	-	-	
	12	-	-	-	-	-	-	-	-	-	-	-	-	-	-	-	
Service units																	
MSB-FRC	4	■	-	■	-	■	-	-	■	-	-	-	■	-	-	■	825
	6	■	■	■	-	■	-	-	■	-	-	-	■	-	-	■	
	9	-	-	-	-	-	-	-	-	-	-	-	-	-	-	-	
	12	-	-	-	-	-	-	-	-	-	-	-	-	-	-	-	
Individual devices																	
Filter regulators MS-LFR	4	■	■	■	■	■	-	■	■	■	■	■	■	■	■	■	828
	6	■	■	■	■	■	■	■	■	-	■	■	■	■	■	■	
	9	-	■	■	■	■	■	■	■	-	■	■	■	■	■	■	
	12	-	■	■	-	■	■	■	■	■	■	■	■	■	■	■	
Filters MS-LF	4	■	■	■	■	■	-	-	-	-	-	-	-	-	-	■	ms*-lf
	6	■	■	■	■	■	■	-	-	-	-	-	-	-	-	■	
	9	-	■	■	■	■	■	-	-	-	-	-	-	-	-	■	
	12	-	■	■	-	■	■	-	-	-	-	-	-	-	-	■	
Fine and micro filters MS-LFM	4	■	■	■	■	■	-	-	-	-	-	-	-	-	-	■	ms*-lfm
	6	■	■	■	■	■	■	-	-	-	-	-	-	-	-	■	
	9	-	■	■	■	■	■	-	-	-	-	-	-	-	-	■	
	12	-	■	■	-	■	■	-	-	-	-	-	-	-	-	■	
Activated carbon filters MS-LFX	4	■	■	-	-	-	-	-	-	-	-	-	-	-	-	■	ms*-lfx
	6	■	■	-	-	-	-	-	-	-	-	-	-	-	-	■	
	9	-	■	-	-	-	-	-	-	-	-	-	-	-	-	■	
	12	-	■	-	-	-	-	-	-	-	-	-	-	-	-	■	
Water separators MS-LWS	4	-	-	-	-	-	-	-	-	-	-	-	-	-	-	-	ms*-lws
	6	-	■	-	-	■	■	-	-	-	-	-	-	-	-	■	
	9	-	■	-	-	■	■	-	-	-	-	-	-	-	-	■	
	12	-	■	-	-	■	■	-	-	-	-	-	-	-	-	■	







Product range overview

Type	Size	Pneumatic connection in housing	Connecting plate	Pressure regulation range [bar]						Supply voltage			
				0.05	0.05	0.1	0.3	0.1	0.5	24 V DC, pin allocation to EN 175301	24 V DC, connection M12 to IEC 61076-2-101	110 V AC, pin allocation to EN 175301	230 V AC, pin allocation to EN 175301
Code			AG...	D2	D4	D5	D6	D7	D8	V24	V24P	V110	V230
Individual devices													
Pressure regulators MS-LR		4	G1/8, G1/4	G1/8, G1/4, G3/8	-	-	■	■	■	-	-	-	-
		6	G1/4, G3/8, G1/2	G1/4, G3/8, G1/2, G3/4	-	-	■	■	■	■	-	-	-
		9	G3/4, G1	G1/2, G3/4, G1, G1 1/4, G1 1/2	-	-	■	■	-	-	-	-	-
		12	-	G1, G1 1/4, G1 1/2, G2	-	-	-	■	■	■	-	-	-
Pressure regulators MS-LRB		4	G1/4	G1/8, G1/4, G3/8	-	-	■	■	■	-	-	-	-
		6	G1/2	G1/4, G3/8, G1/2, G3/4	-	-	■	■	■	■	-	-	-
		9	-	-	-	-	-	-	-	-	-	-	-
		12	-	-	-	-	-	-	-	-	-	-	-
Precision pressure regulators MS-LRP		4	-	-	-	-	-	-	-	-	-	-	-
		6	G1/4, G3/8, G1/2	G1/4, G3/8, G1/2, G3/4	■	■	■	-	■	-	-	-	-
		9	-	-	-	-	-	-	-	-	-	-	-
		12	-	-	-	-	-	-	-	-	-	-	-
Precision pressure regulators MS-LRPB		4	-	-	-	-	-	-	-	-	-	-	-
		6	G1/2	G1/4, G3/8, G1/2, G3/4	■	■	■	-	■	-	-	-	-
		9	-	-	-	-	-	-	-	-	-	-	-
		12	-	-	-	-	-	-	-	-	-	-	-
Electric pressure regulators MS-LRE		4	-	-	-	-	-	-	-	-	-	-	-
		6	G1/4, G3/8, G1/2	G1/4, G3/8, G1/2, G3/4	-	-	■	■	■	■	-	-	-
		9	-	-	-	-	-	-	-	-	-	-	-
		12	-	-	-	-	-	-	-	-	-	-	-
Lubricators MS-LOE		4	G1/8, G1/4	G1/8, G1/4, G3/8	-	-	-	-	-	-	-	-	-
		6	G1/4, G3/8, G1/2	G1/4, G3/8, G1/2, G3/4	-	-	-	-	-	-	-	-	-
		9	G3/4, G1	G1/2, G3/4, G1, G1 1/4, G1 1/2	-	-	-	-	-	-	-	-	-
		12	-	G1, G1 1/4, G1 1/2, G2	-	-	-	-	-	-	-	-	-
On-off valves MS-EM(1)		4	G1/8, G1/4	G1/8, G1/4, G3/8	-	-	-	-	-	-	-	-	-
		6	G1/4, G3/8, G1/2	G1/4, G3/8, G1/2, G3/4	-	-	-	-	-	-	-	-	-
		9	G3/4, G1	G1/2, G3/4, G1, G1 1/4, G1 1/2	-	-	-	-	-	-	-	-	-
		12	-	G1, G1 1/4, G1 1/2, G2	-	-	-	-	-	-	-	-	-
On-off valves MS-EE		4	G1/8, G1/4	G1/8, G1/4, G3/8	-	-	-	-	-	-	■	-	■
		6	G1/4, G3/8, G1/2	G1/4, G3/8, G1/2, G3/4	-	-	-	-	-	-	■	-	■
		9	G3/4, G1	G1/2, G3/4, G1, G1 1/4, G1 1/2	-	-	-	-	-	-	■	■	■
		12	-	G1, G1 1/4, G1 1/2, G2	-	-	-	-	-	-	■	■	■
Soft-start valves MS-DL		4	G1/8, G1/4	G1/8, G1/4, G3/8	-	-	-	-	-	-	-	-	-
		6	G1/4, G3/8, G1/2	G1/4, G3/8, G1/2, G3/4	-	-	-	-	-	-	-	-	-
		9	-	-	-	-	-	-	-	-	-	-	-
		12	-	G1, G1 1/4, G1 1/2, G2	-	-	-	-	-	-	-	-	-
Soft-start valves MS-DE		4	G1/8, G1/4	G1/8, G1/4, G3/8	-	-	-	-	-	-	■	-	■
		6	G1/4, G3/8, G1/2	G1/4, G3/8, G1/2, G3/4	-	-	-	-	-	-	■	-	■
		9	-	-	-	-	-	-	-	-	-	-	-
		12	-	G1, G1 1/4, G1 1/2, G2	-	-	-	-	-	-	■	■	■

Product range overview

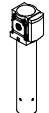
Type	Size	Bowl guard		Pressure indicator				Security			Options		→ Page/ online
		Plastic bowl guard	Metal bowl	Cover plate (without pressure gauge)	Integrated MS pressure gauge	Adapter plate for EN pressure gauge G1/8	Adapter plate for EN pressure gauge G1/4	Pressure sensor	Rotary knob with detent, can be locked using accessories	Rotary knob with integrated lock	Silencer	Flow direction from right to left	
Code		R	U	VS	AG	A8	A4	AD...	AS	E11	S	Z	
Individual devices													
Pressure regulators MS-LR	4	-	-	■	■	■	■	■	■	■	-	■	839
	6	-	-	■	■	-	■	■	■	■	-	■	
	9	-	-	■	■	-	■	■	■	■	-	■	
	12	-	-	■	■	-	■	-	■	■	-	■	
Pressure regulators MS-LRB	4	-	-	■	■	■	■	■	■	■	-	■	849
	6	-	-	■	■	-	■	■	■	■	-	■	
	9	-	-	■	■	-	■	■	■	■	-	■	
	12	-	-	■	■	-	■	■	■	■	-	■	
Precision pressure regulators MS-LRP	4	-	-	■	-	■	■	■	■	■	-	■	ms6-lrp
	6	-	-	■	-	■	■	■	■	■	-	■	
	9	-	-	■	-	■	■	■	■	■	-	■	
	12	-	-	■	-	■	■	■	■	■	-	■	
Precision pressure regulators MS-LRPB	4	-	-	■	-	■	■	■	■	■	-	■	ms6-lrpb
	6	-	-	■	-	■	■	■	■	■	-	■	
	9	-	-	■	-	■	■	■	■	■	-	■	
	12	-	-	■	-	■	■	■	■	■	-	■	
Electric pressure regulators MS-LRE	4	-	-	■	■	-	■	-	-	-	-	■	ms6-lre
	6	-	-	■	■	-	■	-	-	-	-	■	
	9	-	-	■	■	-	■	-	-	-	-	■	
	12	-	-	■	■	-	■	-	-	-	-	■	
Lubricators MS-LOE	4	■	■	-	-	-	-	-	-	-	-	■	ms*-loe
	6	■	■	-	-	-	-	-	-	-	-	■	
	9	-	■	-	-	-	-	-	-	-	-	■	
	12	-	■	-	-	-	-	-	-	-	-	■	
On-off valves MS-EM(1)	4	-	-	■	■	■	■	■	-	-	■	■	855
	6	-	-	■	■	-	■	■	-	-	■	■	
	9	-	-	■	■	-	■	■	-	-	■	■	
	12	-	-	■	■	-	■	■	-	-	■	■	
On-off valves MS-EE	4	-	-	■	■	■	■	■	-	-	■	■	862
	6	-	-	■	■	-	■	■	-	-	■	■	
	9	-	-	■	■	-	■	■	-	-	■	■	
	12	-	-	■	■	-	■	■	-	-	■	■	
Soft-start valves MS-DL	4	-	-	■	■	■	■	■	-	-	-	■	870
	6	-	-	■	■	-	■	■	-	-	-	■	
	9	-	-	■	■	-	■	■	-	-	-	■	
	12	-	-	■	■	-	■	■	-	-	-	■	
Soft-start valves MS-DE	4	-	-	■	■	■	■	■	-	-	-	■	ms*-de
	6	-	-	■	■	-	■	■	-	-	-	■	
	9	-	-	■	■	-	■	■	-	-	-	■	
	12	-	-	■	■	-	■	■	-	-	-	■	

Product range overview

Type	Size	Pneumatic connection in housing	Connecting plate	Performance Level		Supply voltage				
				Category 1, 1-channel	Category 4, 2-channel with self-monitoring	24 V DC, pin allocation to EN 175301	24 V DC, connection M12 to IEC 61076-2-101 / to EN 60947-5-2	110 V AC, pin allocation to EN 175301	230 V AC, pin allocation to EN 175301	
Code			AG...	C	E	V24	V24P	V110	V230	
Individual devices										
Soft-start/quick exhaust valves MS-SV-C		4	–							
		6	G1/2	G1/4, G3/8, G1/2, G3/4	■	–	■	■	■	■
		9	G3/4, G1	G1/2, G3/4, G1, G11/4, G11/2	■	–	■	■	■	■
		12	–							
Soft-start/quick exhaust valves MS-SV-E		4	–							
		6	G1/2	G1/4, G3/8, G1/2, G3/4	–	■	■	–	–	–
		9	–							
		12	–							
Membrane air dryers MS-LDM1		4	G1/8, G1/4	G1/8, G1/4, G3/8	–	–	–	–	–	–
		6	G1/4, G3/8, G1/2	G1/4, G3/8, G1/2, G3/4	–	–	–	–	–	–
		9	–							
		12	–							
Branching modules MS-FRM		4	G1/8, G1/4	G1/8, G1/4, G3/8	–	–	–	–	–	–
		6	G1/4, G3/8, G1/2	G1/4, G3/8, G1/2, G3/4	–	–	–	–	–	–
		9	G3/4, G1	G1/2, G3/4, G1, G11/4, G11/2	–	–	–	–	–	–
		12	–	G1, G11/4, G11/2, G2	–	–	–	–	–	–
Distributor blocks MS-FRM-FRZ		4	G1/4	–	–	–	–	–	–	
		6	G1/2	–	–	–	–	–	–	
		9	–							
		12	–							
Flow sensors SFAM		4	–							
		6	G1/2	G1/2	–	–	–	–	–	–
		9	–	G1, G11/2	–	–	–	–	–	–
		12	–							

Product range overview

Type	Size	Bowl guard		Pressure indicator				Electrical output		Options		→ Page/ online	
		Plastic bowl guard	Metal bowl	Cover plate (without pressure gauge)	Integrated MS pressure gauge	Adapter plate for EN pressure gauge G1/8	Adapter plate for EN pressure gauge G1/4	Pressure sensor	2x PNP or NPN, 1 analogue output 4 ... 20 mA	2x PNP or NPN, 1 analogue output 0 ... 10 V	Silencer		Flow direction from right to left
Code		R	U	VS	AG	A8	A4	AD...	2SA	2SV	S	Z/R	
Individual devices													
Soft-start/quick exhaust valves MS-SV-C	4	-											875
	6	-	-	■	■	-	■	■	-	-	■	■	
	9	-	-	■	■	-	■	■	-	-	■	■	
	12	-											
Soft-start/quick exhaust valves MS-SV-E	4	-											ms6-sv
	6	-	-	■	■	-	■	■	-	-	■	■	
	9	-											
	12	-											
Membrane air dryers MS-LDM1	4	-	■	-	-	-	-	-	-	-	-	■	ms*-ldm1
	6	-	■	-	-	-	-	-	-	-	-	■	
	9	-											
	12	-											
Branching modules MS-FRM	4	-	-	■	■	■	■	■	-	-	-	■	882
	6	-	-	■	■	-	■	■	-	-	-	■	
	9	-	-	■	■	-	■	■	-	-	-	■	
	12	-	-	■	-	-	-	-	-	-	-	-	
Distributor blocks MS-FRM-FRZ	4	-	-	-	-	-	-	-	-	-	-	■	ms*-frz
	6	-	-	-	-	-	-	-	-	-	-	■	
	9	-											
	12	-											
Flow sensors SFAM	4	-											sfam
	6	-	-	-	-	-	-	-	■	■	-	■	
	9	-	-	-	-	-	-	-	■	■	-	■	
	12	-											

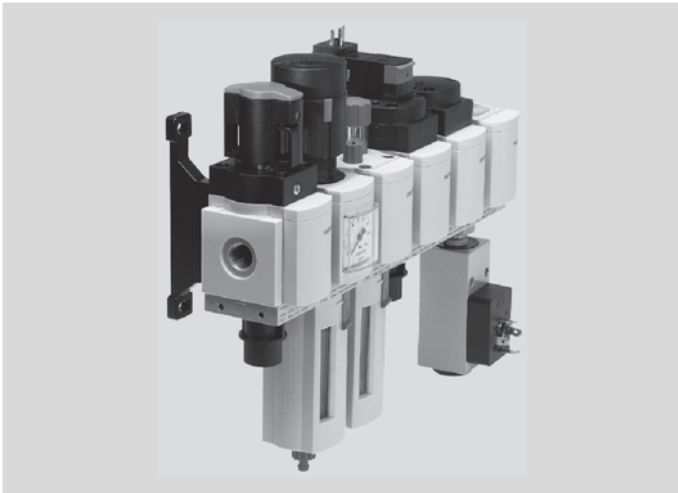

- Pre-assembled combinations, fully assembled and tested
- Rapid availability
- 2 sizes:
MS4 – grid dimension 40 mm, MS6 – grid dimension 62 mm

→ www.festo.com/catalogue/msb

Product range overview

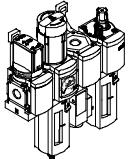
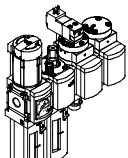
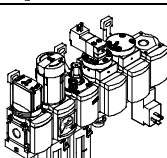
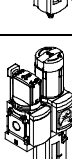
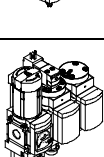
Combina- tion	Version		Size	Pneumatic connection	Flow rate [l/min]	→ Page/ online
Service unit combination						
1	 <ul style="list-style-type: none"> • On-off valve MS-EM1, manually operated • Filter regulator MS-LFR with pressure gauge • Branching module MS-FRM-Y with pressure switch • Lubricator MS-LOE • Mounting bracket MS-WP 		4	G1/4	900 ... 950	816
			6	G1/2	3,200 ... 3,300	
2	 <ul style="list-style-type: none"> • Filter regulator MS-LFR with pressure gauge • Lubricator MS-LOE • On-off valve MS-EE-V24/10V24, electrically actuated (24 V DC) • Soft-start valve MS-DL, pneumatically actuated • Mounting bracket MS-WP 		4	G1/4	550 ... 600	817
			6	G1/2	1,900 ... 2,000	
3	 <ul style="list-style-type: none"> • On-off valve MS-EM1, manually operated • Filter regulator MS-LFR with pressure gauge • Lubricator MS-LOE • On-off valve MS-EE-V24/10V24, electrically actuated (24 V DC) • Soft-start valve MS-DL, pneumatically actuated • Branching module MS-FRM-Y with pressure switch • Mounting bracket MS-WP 		4	G1/4	550 ... 600	818
			6	G1/2	2,100 ... 2,300	
4	 <ul style="list-style-type: none"> • On-off valve MS-EM1, manually operated • Filter regulator MS-LFR with pressure gauge • Mounting bracket MS-WP 		4	G1/4	950 ... 1,000	819
			6	G1/2	4,800 ... 5,100	
5	 <ul style="list-style-type: none"> • Filter regulator MS-LFR with pressure gauge • On-off valve MS-EE-V24/10V24, electrically actuated (24 V DC) • Soft-start valve MS-DL, pneumatically actuated • Mounting bracket MS-WP 		4	G1/4	700 ... 750	820
			6	G1/2	3,000 ... 3,100	

Product range overview

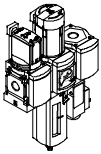
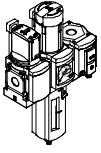
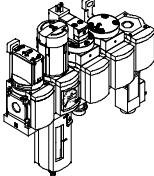
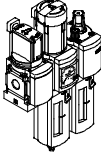
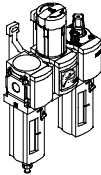
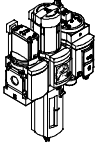
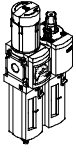
Combina- tion	Version		Size	Pneumatic connection	Flow rate [l/min]	→ Page/ online
Service unit combination						
6		<ul style="list-style-type: none"> • On-off valve MS-EM1, manually operated • Filter regulator MS-LFR with pressure gauge • Branching module MS-FRM-Y with pressure switch • Mounting bracket MS-WP 	4	G1/4	1,250 ... 1,300	821
			6	G1/2	4,400 ... 4,500	
		<ul style="list-style-type: none"> • On-off valve MS-EM1, manually operated • Filter regulator MS-LFR with pressure gauge • Branching module MS-FRM-AD7 with pressure sensor for operational status indicator • Mounting bracket MS-WP 	4	G1/4	1,600	msb
			6	G1/2	4,500	
7		<ul style="list-style-type: none"> • On-off valve MS-EM1, manually operated • Filter regulator MS-LFR with pressure gauge • On-off valve MS-EE-V24/10V24, electrically actuated (24 V DC) • Soft-start valve MS-DL, pneumatically actuated • Branching module MS-FRM-Y with pressure switch • Mounting bracket MS-WP 	4	G1/4	700 ... 750	822
			6	G1/2	3,000 ... 3,100	
8		<ul style="list-style-type: none"> • On-off valve MS-EM1, manually operated • Filter regulator MS-LFR with pressure gauge • Lubricator MS-LOE • Mounting bracket MS-WP 	4	G1/4	700 ... 750	823
			6	G1/2	3,000 ... 3,100	
9		<ul style="list-style-type: none"> • Filter MS-LF • Pressure regulator MS-LR with pressure gauge • Lubricator MS-LOE • Mounting bracket MS-WP 	4	G1/4	700 ... 1,300	msb
			6	G1/2	3,500 ... 4,700	
10		<ul style="list-style-type: none"> • On-off valve MS-EM1, manually operated • Filter regulator MS-LFR with pressure gauge • On-off valve MS-EE-10V24P-AD7, electrically actuated (24 V DC), with pressure sensor for operational status indicator • Mounting bracket MS-WP 	4	G1/4	1,400	msb
			6	G1/2	4,000	
Service unit						
MSB-FRC		<ul style="list-style-type: none"> • Filter regulator MS-LFR with pressure gauge • Lubricator MS-LOE 	4	G1/8, G1/4	800 ... 1,400	825
			6	G1/4, G3/8, G1/2	1,700 ... 4,800	

Service unit combinations MSB, MS series

Technical data – Service unit combination 1

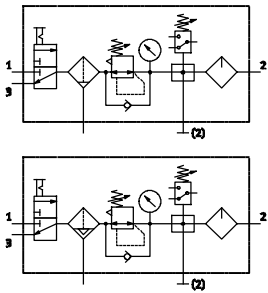

- Manual on-off valve
- Filter regulator with pressure gauge
- Branching module with pressure switch
- Lubricator
- Mounting bracket

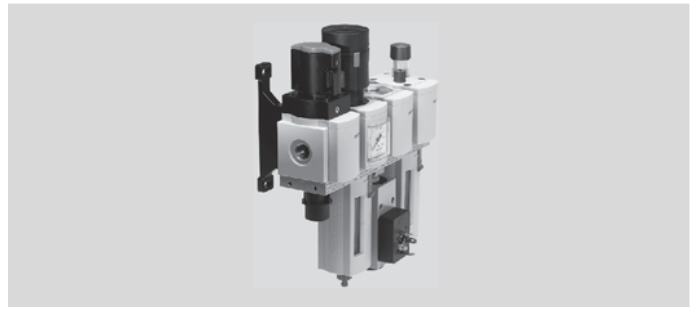

Technical data		Download CAD data → www.festo.com			
Size	MSB4		MSB6		
Pneumatic connection	G $\frac{1}{4}$		G $\frac{1}{2}$		
Regulator function	With primary pressure compensation, with return flow action, with secondary venting, output pressure constant				
Type of mounting	Via accessories				
Mounting position	Vertical $\pm 5^\circ$				
Grade of filtration	[μm]	40	5	40	5
Air purity class at the output		Compressed air to ISO 8573-1:2010 [7:4:4]	Compressed air to ISO 8573-1:2010 [6:4:4]	Compressed air to ISO 8573-1:2010 [7:4:4]	Compressed air to ISO 8573-1:2010 [6:4:4]
Bowl guard	Plastic bowl guard				
Condensate drain	Manual rotary				
	Fully automatic				
Actuation security	Rotary knob with detent, can be locked using accessories				
Pressure regulation range	[bar]	1 ... 12		1 ... 12	
Pressure indication	Via pressure gauge				
Length/width/height	[mm]	80/160 (164) ¹⁾ /219 (222) ²⁾		100/248 (253) ¹⁾ /301 (304) ²⁾	

1) Value in brackets with cover cap MS...-END as accessory.

2) Value in brackets with fully automatic condensate drain.

Standard nominal flow rate q_{nN}		MSB4		MSB6	
q_{nN} [l/min]	Grade of filtration 40 μm	950		3,300	
	Grade of filtration 5 μm	900		3,200	

Operating conditions		Manual rotary		Fully automatic	
Condensate drain		Manual rotary		Fully automatic	
Size		MSB4	MSB6	MSB4	MSB6
Operating medium		Compressed air to ISO 8573-1:2010 [7:4:4]			
		Inert gases			
Note on operating/pilot medium		Lubricated operation possible (in which case lubricated operation will always be required)			
Operating pressure	[bar]	1.5 ... 14		2 ... 12	
Ambient temperature	[°C]	-10 ... +60		-10 ... +60	

Ordering data

Size	Condensate drain	Connection	Grade of filtration 5 μm		Grade of filtration 40 μm	
			Part No.	Type	Part No.	Type
MSB4	Manual rotary	G $\frac{1}{4}$	542307	MSB4- $\frac{1}{4}$:C3J3F3M1-WP	542295	MSB4- $\frac{1}{4}$:C3J1F3M1-WP
	Fully automatic	G $\frac{1}{4}$	542313	MSB4- $\frac{1}{4}$:C3J4F3M1-WP	542301	MSB4- $\frac{1}{4}$:C3J2F3M1-WP
MSB6	Manual rotary	G $\frac{1}{2}$	542283	MSB6- $\frac{1}{2}$:C3J3F3M1-WP	542271	MSB6- $\frac{1}{2}$:C3J1F3M1-WP
	Fully automatic	G $\frac{1}{2}$	542289	MSB6- $\frac{1}{2}$:C3J4F3M1-WP	542277	MSB6- $\frac{1}{2}$:C3J2F3M1-WP

Technical data – Service unit combination 2

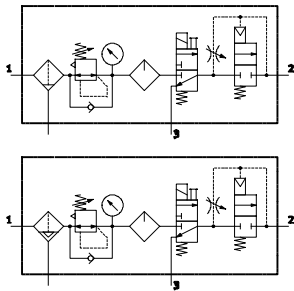

- Filter regulator with pressure gauge
- Lubricator
- Electric on-off valve (24 V DC)
- Pneumatic soft-start valve
- Mounting bracket



Download CAD data → www.festo.com

Technical data		MSB4				MSB6			
Size		MSB4				MSB6			
Pneumatic connection		G1/4				G1/2			
Regulator function		With primary pressure compensation, with return flow action, with secondary venting, output pressure constant							
Type of mounting		Via accessories							
Mounting position		Vertical ±5°							
Grade of filtration	[µm]	40		5		40		5	
Air purity class at the output		Compressed air to ISO 8573-1:2010 [7:4:-]		Compressed air to ISO 8573-1:2010 [6:4:-]		Compressed air to ISO 8573-1:2010 [7:4:-]		Compressed air to ISO 8573-1:2010 [6:4:-]	
Bowl guard		Plastic bowl guard							
Condensate drain		Manual rotary Fully automatic							
Actuation security		Rotary knob with detent, can be locked using accessories							
Pressure regulation range	[bar]	4 ... 9		4 ... 12		4 ... 9		4 ... 12	
Pressure indication		Via pressure gauge							
Length/width/height	[mm]	80/160 (164) ¹⁾ /219 (222) ²⁾				100/248 (253) ¹⁾ /301 (304) ²⁾			

1) Value in brackets with cover cap MS...-END as accessory.
 2) Value in brackets with fully automatic condensate drain.

Standard nominal flow rate q _{NN}		MSB4		MSB6	
q _{NN} [l/min]	Grade of filtration 40 µm	600		2,000	
	Grade of filtration 5 µm	550		1,900	

Operating conditions	Pressure regulation range 4 ... 9 bar				Pressure regulation range 4 ... 12 bar				
	Manual rotary		Fully automatic		Manual rotary		Fully automatic		
Condensate drain	Manual rotary		Fully automatic		Manual rotary		Fully automatic		
Size	MSB4	MSB6	MSB4	MSB6	MSB4	MSB6	MSB4	MSB6	
Operating medium	Compressed air to ISO 8573-1:2010 [-:4:-]		Compressed air to ISO 8573-1:2010 [7:4:-]		Compressed air to ISO 8573-1:2010 [-:4:-]		Compressed air to ISO 8573-1:2010 [7:4:-]		
	Inert gases								
Note on operating/pilot medium	Lubricated operation possible (in which case lubricated operation will always be required)								
Operating pressure	[bar]	4.5 ... 10	4.5 ... 10	4.5 ... 10	4.5 ... 10	4.5 ... 14	4.5 ... 18	4.5 ... 12	4.5 ... 12
Ambient temperature	[°C]	-10 ... +50	-10 ... +50	+5 ... +50	+5 ... +50	-10 ... +60	-10 ... +60	+5 ... +60	+5 ... +60

Ordering data

Size	Condensate drain	Connection	Grade of filtration 5 µm				Grade of filtration 40 µm			
			Part No.	Type	Part No.	Type				
Pressure regulation range 4 ... 9 bar										
MSB4	Manual rotary	G1/4	542632	MSB4-1/4:J3M1D7A1-WP	542628	MSB4-1/4:J1M1D7A1-WP				
	Fully automatic	G1/4	542634	MSB4-1/4:J4M1D7A1-WP	542630	MSB4-1/4:J2M1D7A1-WP				
MSB6	Manual rotary	G1/2	542648	MSB6-1/2:J3M1D7A1-WP	542644	MSB6-1/2:J1M1D7A1-WP				
	Fully automatic	G1/2	542650	MSB6-1/2:J4M1D7A1-WP	542646	MSB6-1/2:J2M1D7A1-WP				
Pressure regulation range 4 ... 12 bar										
MSB4	Manual rotary	G1/4	531106	MSB4-1/4:J3M1D1A1-WP	531102	MSB4-1/4:J1M1D1A1-WP				
	Fully automatic	G1/4	531108	MSB4-1/4:J4M1D1A1-WP	531104	MSB4-1/4:J2M1D1A1-WP				
MSB6	Manual rotary	G1/2	530227	MSB6-1/2:J3M1D1A1-WP	530223	MSB6-1/2:J1M1D1A1-WP				
	Fully automatic	G1/2	530229	MSB6-1/2:J4M1D1A1-WP	530225	MSB6-1/2:J2M1D1A1-WP				

Service unit combinations MSB, MS series

Technical data – Service unit combination 3

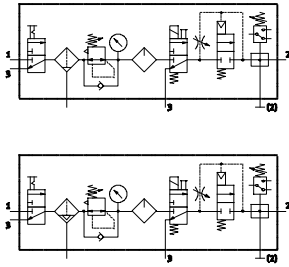

- Manual on-off valve
- Filter regulator with pressure gauge
- Lubricator
- Electric on-off valve (24 V DC)
- Pneumatic soft-start valve
- Branching module with pressure switch
- Mounting bracket

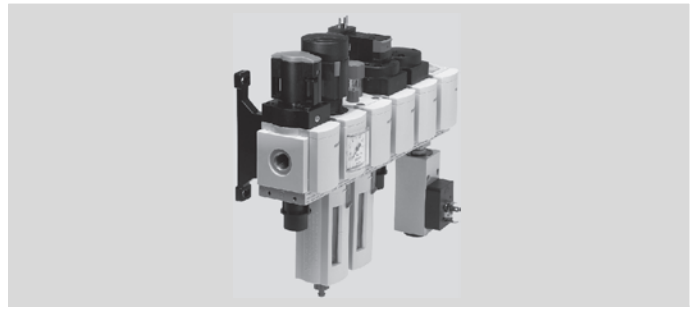

Technical data

Download CAD data → www.festo.com

Size	MSB4		MSB6		
Pneumatic connection	G $\frac{1}{4}$		G $\frac{1}{2}$		
Regulator function	With primary pressure compensation, with return flow action, with secondary venting, output pressure constant				
Type of mounting	Via accessories				
Mounting position	Vertical $\pm 5^\circ$				
Grade of filtration	[μm]	40	5	40	5
Air purity class at the output		Compressed air to ISO 8573-1:2010 [7:4:4]	Compressed air to ISO 8573-1:2010 [6:4:4]	Compressed air to ISO 8573-1:2010 [7:4:4]	Compressed air to ISO 8573-1:2010 [6:4:4]
Bowl guard	Plastic bowl guard				
Condensate drain	Manual rotary Fully automatic				
Actuation security	Rotary knob with detent, can be locked using accessories				
Pressure regulation range	[bar]	4 ... 9		4 ... 9	
	[bar]	4 ... 12		4 ... 12	
Pressure indication	Via pressure gauge				
Length/width/height	[mm]	80/240 (244) ¹⁾ /219 (222) ²⁾		100/372 (377) ¹⁾ /301 (304) ²⁾	

1) Value in brackets with cover cap MS...-END as accessory.

2) Value in brackets with fully automatic condensate drain.

Standard nominal flow rate q_{NN}

Size	MSB4		MSB6	
q_{NN} [l/min]	Grade of filtration 40 μm		2,300	
	Grade of filtration 5 μm		2,100	

Operating conditions

	Pressure regulation range 4 ... 9 bar				Pressure regulation range 4 ... 12 bar				
	Manual rotary		Fully automatic		Manual rotary		Fully automatic		
Size	MSB4	MSB6	MSB4	MSB6	MSB4	MSB6	MSB4	MSB6	
Operating medium	Compressed air to ISO 8573-1:2010 [7:4:4] Inert gases								
Note on operating/pilot medium	Lubricated operation possible (in which case lubricated operation will always be required)								
Operating pressure	[bar]	4.5 ... 10	4.5 ... 10	4.5 ... 10	4.5 ... 10	4.5 ... 14	4.5 ... 18	4.5 ... 12	4.5 ... 12
Ambient temperature	[°C]	-10 ... +50	-10 ... +50	+5 ... +50	+5 ... +50	-10 ... +60	-10 ... +60	+5 ... +60	+5 ... +60

Ordering data

Size	Condensate drain	Connection	Grade of filtration 5 μm		Grade of filtration 40 μm	
			Part No.	Type	Part No.	Type
Pressure regulation range 4 ... 9 bar						
MSB4	Manual rotary	G $\frac{1}{4}$	542624	MSB4- $\frac{1}{4}$:C3J3M1D7A1F3-WP	542619	MSB4- $\frac{1}{4}$:C3J1M1D7A1F3-WP
	Fully automatic	G $\frac{1}{4}$	542626	MSB4- $\frac{1}{4}$:C3J4M1D7A1F3-WP	542622	MSB4- $\frac{1}{4}$:C3J2M1D7A1F3-WP
MSB6	Manual rotary	G $\frac{1}{2}$	542640	MSB6- $\frac{1}{2}$:C3J3M1D7A1F3-WP	542636	MSB6- $\frac{1}{2}$:C3J1M1D7A1F3-WP
	Fully automatic	G $\frac{1}{2}$	542642	MSB6- $\frac{1}{2}$:C3J4M1D7A1F3-WP	542638	MSB6- $\frac{1}{2}$:C3J2M1D7A1F3-WP
Pressure regulation range 4 ... 12 bar						
MSB4	Manual rotary	G $\frac{1}{4}$	542309	MSB4- $\frac{1}{4}$:C3J3M1D1A1F3-WP	542297	MSB4- $\frac{1}{4}$:C3J1M1D1A1F3-WP
	Fully automatic	G $\frac{1}{4}$	542315	MSB4- $\frac{1}{4}$:C3J4M1D1A1F3-WP	542303	MSB4- $\frac{1}{4}$:C3J2M1D1A1F3-WP
MSB6	Manual rotary	G $\frac{1}{2}$	542285	MSB6- $\frac{1}{2}$:C3J3M1D1A1F3-WP	542273	MSB6- $\frac{1}{2}$:C3J1M1D1A1F3-WP
	Fully automatic	G $\frac{1}{2}$	542291	MSB6- $\frac{1}{2}$:C3J4M1D1A1F3-WP	542279	MSB6- $\frac{1}{2}$:C3J2M1D1A1F3-WP

Technical data – Service unit combination 4

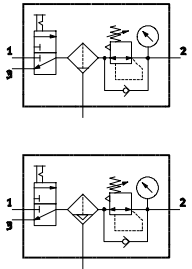

- Manual on-off valve
- Filter regulator with pressure gauge
- Mounting bracket



Download CAD data → www.festo.com

Technical data		MSB4				MSB6	
Size		MSB4				MSB6	
Pneumatic connection		G1/4				G1/2	
Regulator function		With primary pressure compensation, with return flow action, with secondary venting, output pressure constant					
Type of mounting		Via accessories					
Mounting position		Vertical ±5°					
Grade of filtration	[µm]	40		5		40	
Air purity class at the output		Compressed air to ISO 8573-1:2010 [7:4:4]		Compressed air to ISO 8573-1:2010 [6:4:4]		Compressed air to ISO 8573-1:2010 [7:4:4]	
Bowl guard		Plastic bowl guard					
Condensate drain		Manual rotary					
		Fully automatic					
Actuation security		Rotary knob with detent, can be locked using accessories					
Pressure regulation range	[bar]	0.5 ... 12				0.5 ... 12	
Pressure indication		Via pressure gauge					
Length/width/height	[mm]	80/80 (84) ¹⁾ /219 (222) ²⁾				100/124 (129) ¹⁾ /301 (304) ²⁾	

1) Value in brackets with cover cap MS...-END as accessory.

2) Value in brackets with fully automatic condensate drain.

Standard nominal flow rate q _{NN}		MSB4		MSB6	
Size		MSB4		MSB6	
q _{NN} [l/min]	Grade of filtration 40 µm	1,000		5,100	
	Grade of filtration 5 µm	950		4,800	

Operating conditions		Manual rotary		Fully automatic	
Condensate drain		Manual rotary		Fully automatic	
Size		MSB4		MSB6	
Operating medium		Compressed air to ISO 8573-1:2010 [7:4:4]			
		Inert gases			
Note on operating/pilot medium		Lubricated operation possible (in which case lubricated operation will always be required)			
Operating pressure	[bar]	0.8 ... 14		2 ... 12	
Ambient temperature	[°C]	-10 ... +60		-10 ... +60	

Ordering data

Size	Condensate drain	Connection	Grade of filtration 5 µm		Grade of filtration 40 µm	
			Part No.	Type	Part No.	Type
MSB4	Manual rotary	G1/4	542304	MSB4-1/4:C3J3-WP	542292	MSB4-1/4:C3J1-WP
	Fully automatic	G1/4	542310	MSB4-1/4:C3J4-WP	542298	MSB4-1/4:C3J2-WP
MSB6	Manual rotary	G1/2	542280	MSB6-1/2:C3J3-WP	542268	MSB6-1/2:C3J1-WP
	Fully automatic	G1/2	542286	MSB6-1/2:C3J4-WP	542274	MSB6-1/2:C3J2-WP

Service unit combinations MSB, MS series

Technical data – Service unit combination 5

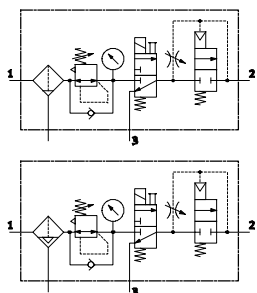

- Filter regulator with pressure gauge
- Electric on-off valve (24 V DC)
- Pneumatic soft-start valve
- Mounting bracket



Download CAD data → www.festo.com

Technical data					
Size	MSB4		MSB6		
Pneumatic connection	G $\frac{1}{4}$		G $\frac{1}{2}$		
Regulator function	With primary pressure compensation, with return flow action, with secondary venting, output pressure constant				
Type of mounting	Via accessories				
Mounting position	Vertical $\pm 5^\circ$				
Grade of filtration	[μm]	40	5	40	5
Air purity class at the output		Compressed air to ISO 8573-1:2010 [7:4:-]	Compressed air to ISO 8573-1:2010 [6:4:-]	Compressed air to ISO 8573-1:2010 [7:4:-]	Compressed air to ISO 8573-1:2010 [6:4:-]
Bowl guard	Plastic bowl guard				
Condensate drain	Manual rotary				
	Fully automatic				
Actuation security	Rotary knob with detent, can be locked using accessories				
Pressure regulation range	[bar]	4 ... 9		4 ... 9	
	[bar]	4 ... 12		4 ... 12	
Pressure indication	Via pressure gauge				
Length/width/height	[mm]	80/120 (124) ¹⁾ /219 (222) ²⁾		100/186 (191) ¹⁾ /301 (304) ²⁾	

1) Value in brackets with cover cap MS...-END as accessory.
 2) Value in brackets with fully automatic condensate drain.

Standard nominal flow rate q_{nN}		MSB4		MSB6	
q_{nN} [l/min]	Grade of filtration 40 μm	750		3,100	
	Grade of filtration 5 μm	700		3,000	

Operating conditions		Pressure regulation range 4 ... 9 bar				Pressure regulation range 4 ... 12 bar			
Condensate drain		Manual rotary		Fully automatic		Manual rotary		Fully automatic	
Size		MSB4	MSB6	MSB4	MSB6	MSB4	MSB6	MSB4	MSB6
Operating medium		Compressed air to ISO 8573-1:2010 [-:4:-]		Compressed air to ISO 8573-1:2010 [7:4:-]		Compressed air to ISO 8573-1:2010 [-:4:-]		Compressed air to ISO 8573-1:2010 [7:4:-]	
		Inert gases							
Note on operating/pilot medium		Lubricated operation possible (in which case lubricated operation will always be required)							
Operating pressure	[bar]	4.5 ... 10	4.5 ... 10	4.5 ... 10	4.5 ... 10	4.5 ... 14	4.5 ... 18	4.5 ... 12	4.5 ... 12
Ambient temperature	[°C]	-10 ... +50	-10 ... +50	+5 ... +50	+5 ... +50	-10 ... +60	-10 ... +60	+5 ... +60	+5 ... +60

Ordering data

Size	Condensate drain	Connection	Grade of filtration 5 μm		Grade of filtration 40 μm	
			Part No.	Type	Part No.	Type
Pressure regulation range 4 ... 9 bar						
MSB4	Manual rotary	G $\frac{1}{4}$	542631	MSB4- $\frac{1}{4}$:J3D7A1-WP	542627	MSB4- $\frac{1}{4}$:J1D7A1-WP
	Fully automatic	G $\frac{1}{4}$	542633	MSB4- $\frac{1}{4}$:J4D7A1-WP	542629	MSB4- $\frac{1}{4}$:J2D7A1-WP
MSB6	Manual rotary	G $\frac{1}{2}$	542647	MSB6- $\frac{1}{2}$:J3D7A1-WP	542643	MSB6- $\frac{1}{2}$:J1D7A1-WP
	Fully automatic	G $\frac{1}{2}$	542649	MSB6- $\frac{1}{2}$:J4D7A1-WP	542645	MSB6- $\frac{1}{2}$:J2D7A1-WP
Pressure regulation range 4 ... 12 bar						
MSB4	Manual rotary	G $\frac{1}{4}$	531105	MSB4- $\frac{1}{4}$:J3D1A1-WP	531101	MSB4- $\frac{1}{4}$:J1D1A1-WP
	Fully automatic	G $\frac{1}{4}$	531107	MSB4- $\frac{1}{4}$:J4D1A1-WP	531103	MSB4- $\frac{1}{4}$:J2D1A1-WP
MSB6	Manual rotary	G $\frac{1}{2}$	530226	MSB6- $\frac{1}{2}$:J3D1A1-WP	530222	MSB6- $\frac{1}{2}$:J1D1A1-WP
	Fully automatic	G $\frac{1}{2}$	530228	MSB6- $\frac{1}{2}$:J4D1A1-WP	530224	MSB6- $\frac{1}{2}$:J2D1A1-WP

Technical data – Service unit combination 6

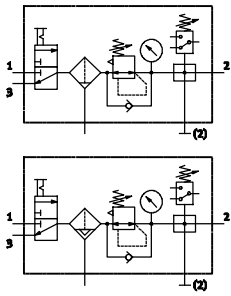

- Manual on-off valve
- Filter regulator with pressure gauge
- Branching module with pressure switch
- Mounting bracket



Download CAD data → www.festo.com

Technical data					
Size	MSB4		MSB6		
Pneumatic connection	G1/4		G1/2		
Regulator function	With primary pressure compensation, with return flow action, with secondary venting, output pressure constant				
Type of mounting	Via accessories				
Mounting position	Vertical ±5°				
Grade of filtration [µm]	40	5	40	5	
Air purity class at the output	Compressed air to ISO 8573-1:2010 [7:4:4]	Compressed air to ISO 8573-1:2010 [6:4:4]	Compressed air to ISO 8573-1:2010 [7:4:4]	Compressed air to ISO 8573-1:2010 [6:4:4]	
Bowl guard	Plastic bowl guard				
Condensate drain	Manual rotary				
	Fully automatic				
Actuation security	Rotary knob with detent, can be locked using accessories				
Pressure regulation range [bar]	0.5 ... 12		0.5 ... 12		
Pressure indication	Via pressure gauge				
Length/width/height [mm]	80/120 (124) ¹⁾ /219 (222) ²⁾		100/186 (191) ¹⁾ /301 (304) ²⁾		

1) Value in brackets with cover cap MS...-END as accessory.
 2) Value in brackets with fully automatic condensate drain.

Standard nominal flow rate q _{NN}			
Size	MSB4		MSB6
q _{NN} [l/min]	Grade of filtration 40 µm	1,300	4,500
	Grade of filtration 5 µm	1,250	4,400

Operating conditions					
Condensate drain	Manual rotary		Fully automatic		
Size	MSB4	MSB6	MSB4	MSB6	
Operating medium	Compressed air to ISO 8573-1:2010 [7:4:4]				
	Inert gases				
Note on operating/pilot medium	Lubricated operation possible (in which case lubricated operation will always be required)				
Operating pressure [bar]	0.8 ... 14	0.8 ... 18	2 ... 12	2 ... 12	
Ambient temperature [°C]	-10 ... +60	-10 ... +60	+5 ... +60	+5 ... +60	

Ordering data

Size	Condensate drain	Connection	Grade of filtration 5 µm		Grade of filtration 40 µm	
			Part No.	Type	Part No.	Type
MSB4	Manual rotary	G1/4	542306	MSB4-1/4:C3J3F3-WP	542294	MSB4-1/4:C3J1F3-WP
	Fully automatic	G1/4	542312	MSB4-1/4:C3J4F3-WP	542300	MSB4-1/4:C3J2F3-WP
MSB6	Manual rotary	G1/2	542282	MSB6-1/2:C3J3F3-WP	542270	MSB6-1/2:C3J1F3-WP
	Fully automatic	G1/2	542288	MSB6-1/2:C3J4F3-WP	542276	MSB6-1/2:C3J2F3-WP

Technical data – Service unit combination 7

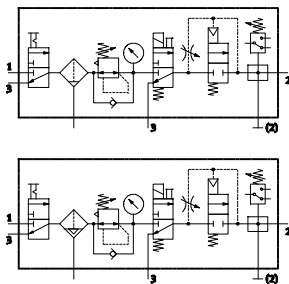

- Manual on-off valve
- Filter regulator with pressure gauge
- Electric on-off valve (24 V DC)
- Pneumatic soft-start valve
- Branching module with pressure switch
- Mounting bracket



Technical data		Download CAD data → www.festo.com			
Size	MSB4		MSB6		
Pneumatic connection	G $\frac{1}{4}$		G $\frac{1}{2}$		
Regulator function	With primary pressure compensation, with return flow action, with secondary venting, output pressure constant				
Type of mounting	Via accessories				
Mounting position	Vertical $\pm 5^\circ$				
Grade of filtration	[μm]	40	5	40	5
Air purity class at the output		Compressed air to ISO 8573-1:2010 [7:4:4]	Compressed air to ISO 8573-1:2010 [6:4:4]	Compressed air to ISO 8573-1:2010 [7:4:4]	Compressed air to ISO 8573-1:2010 [6:4:4]
Bowl guard	Plastic bowl guard				
Condensate drain	Manual rotary				
	Fully automatic				
Actuation security	Rotary knob with detent, can be locked using accessories				
Pressure regulation range	[bar]	4 ... 9		4 ... 9	
	[bar]	4 ... 12		4 ... 12	
Pressure indication	Via pressure gauge				
Length/width/height	[mm]	80/200 (204) ¹⁾ /219 (222) ²⁾		100/310 (315) ¹⁾ /301 (304) ²⁾	

1) Value in brackets with cover cap MS...-END as accessory.

2) Value in brackets with fully automatic condensate drain.

Standard nominal flow rate q_{NN}		MSB4		MSB6	
q_{NN} [l/min]	Grade of filtration 40 μm	750		3,100	
	Grade of filtration 5 μm	700		3,000	

Operating conditions		Pressure regulation range 4 ... 9 bar				Pressure regulation range 4 ... 12 bar			
Condensate drain		Manual rotary		Fully automatic		Manual rotary		Fully automatic	
Size		MSB4	MSB6	MSB4	MSB6	MSB4	MSB6	MSB4	MSB6
Operating medium		Compressed air to ISO 8573-1:2010 [7:4:4]							
		Inert gases							
Note on operating/pilot medium		Lubricated operation possible (in which case lubricated operation will always be required)							
Operating pressure	[bar]	4.5 ... 10	4.5 ... 10	4.5 ... 10	4.5 ... 10	4.5 ... 14	4.5 ... 18	4.5 ... 12	4.5 ... 12
Ambient temperature	[°C]	-10 ... +50	-10 ... +50	+5 ... +50	+5 ... +50	-10 ... +60	-10 ... +60	+5 ... +60	+5 ... +60

Ordering data

Size	Condensate drain	Connection	Grade of filtration 5 μm		Grade of filtration 40 μm	
			Part No.	Type	Part No.	Type
Pressure regulation range 4 ... 9 bar						
MSB4	Manual rotary	G $\frac{1}{4}$	542623	MSB4- $\frac{1}{4}$:C3J3D7A1F3-WP	542618	MSB4- $\frac{1}{4}$:C3J1D7A1F3-WP
	Fully automatic	G $\frac{1}{4}$	542625	MSB4- $\frac{1}{4}$:C3J4D7A1F3-WP	542621	MSB4- $\frac{1}{4}$:C3J2D7A1F3-WP
MSB6	Manual rotary	G $\frac{1}{2}$	542639	MSB6- $\frac{1}{2}$:C3J3D7A1F3-WP	542635	MSB6- $\frac{1}{2}$:C3J1D7A1F3-WP
	Fully automatic	G $\frac{1}{2}$	542641	MSB6- $\frac{1}{2}$:C3J4D7A1F3-WP	542637	MSB6- $\frac{1}{2}$:C3J2D7A1F3-WP
Pressure regulation range 4 ... 12 bar						
MSB4	Manual rotary	G $\frac{1}{4}$	542305	MSB4- $\frac{1}{4}$:C3J3D1A1F3-WP	542293	MSB4- $\frac{1}{4}$:C3J1D1A1F3-WP
	Fully automatic	G $\frac{1}{4}$	542311	MSB4- $\frac{1}{4}$:C3J4D1A1F3-WP	542299	MSB4- $\frac{1}{4}$:C3J2D1A1F3-WP
MSB6	Manual rotary	G $\frac{1}{2}$	542281	MSB6- $\frac{1}{2}$:C3J3D1A1F3-WP	542269	MSB6- $\frac{1}{2}$:C3J1D1A1F3-WP
	Fully automatic	G $\frac{1}{2}$	542287	MSB6- $\frac{1}{2}$:C3J4D1A1F3-WP	542275	MSB6- $\frac{1}{2}$:C3J2D1A1F3-WP

Technical data – Service unit combination 8

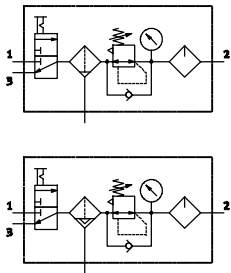

- Manual on-off valve
- Filter regulator with pressure gauge
- Lubricator
- Mounting bracket



Download CAD data → www.festo.com

Technical data		MSB4				MSB6	
Size		MSB4				MSB6	
Pneumatic connection		G1/4				G1/2	
Regulator function		With primary pressure compensation, with return flow action, with secondary venting, output pressure constant					
Type of mounting		Via accessories					
Mounting position		Vertical ±5°					
Grade of filtration	[µm]	40		5		40	
Air purity class at the output		Compressed air to ISO 8573-1:2010 [7:4:4]		Compressed air to ISO 8573-1:2010 [6:4:4]		Compressed air to ISO 8573-1:2010 [7:4:4]	
Bowl guard		Plastic bowl guard					
Condensate drain		Manual rotary					
		Fully automatic					
Actuation security		Rotary knob with detent, can be locked using accessories					
Pressure regulation range	[bar]	1 ... 12				1 ... 12	
Pressure indication		Via pressure gauge					
Length/width/height	[mm]	80/120 (124) ¹⁾ /219 (222) ²⁾				100/186 (191) ¹⁾ /301 (304) ²⁾	

1) Value in brackets with cover cap MS...-END as accessory.
 2) Value in brackets with fully automatic condensate drain.

Standard nominal flow rate q _{NN}		MSB4		MSB6	
Size		MSB4		MSB6	
q _{NN} [l/min]	Grade of filtration 40 µm	750		3,100	
	Grade of filtration 5 µm	700		3,000	

Operating conditions		Manual rotary		Fully automatic	
Condensate drain		Manual rotary		Fully automatic	
Size		MSB4		MSB6	
Operating medium		Compressed air to ISO 8573-1:2010 [7:4:4]			
		Inert gases			
Note on operating/pilot medium		Lubricated operation possible (in which case lubricated operation will always be required)			
Operating pressure	[bar]	1.5 ... 14		2 ... 12	
Ambient temperature	[°C]	-10 ... +60		-10 ... +60	

Ordering data

Size	Condensate drain	Connection	Grade of filtration 5 µm		Grade of filtration 40 µm	
			Part No.	Type	Part No.	Type
MSB4	Manual rotary	G1/4	542308	MSB4-1/4:C3J3M1-WP	542296	MSB4-1/4:C3J1M1-WP
	Fully automatic	G1/4	542314	MSB4-1/4:C3J4M1-WP	542302	MSB4-1/4:C3J2M1-WP
MSB6	Manual rotary	G1/2	542284	MSB6-1/2:C3J3M1-WP	542272	MSB6-1/2:C3J1M1-WP
	Fully automatic	G1/2	542290	MSB6-1/2:C3J4M1-WP	542278	MSB6-1/2:C3J2M1-WP

Service unit combinations MSB, MS series

Accessories

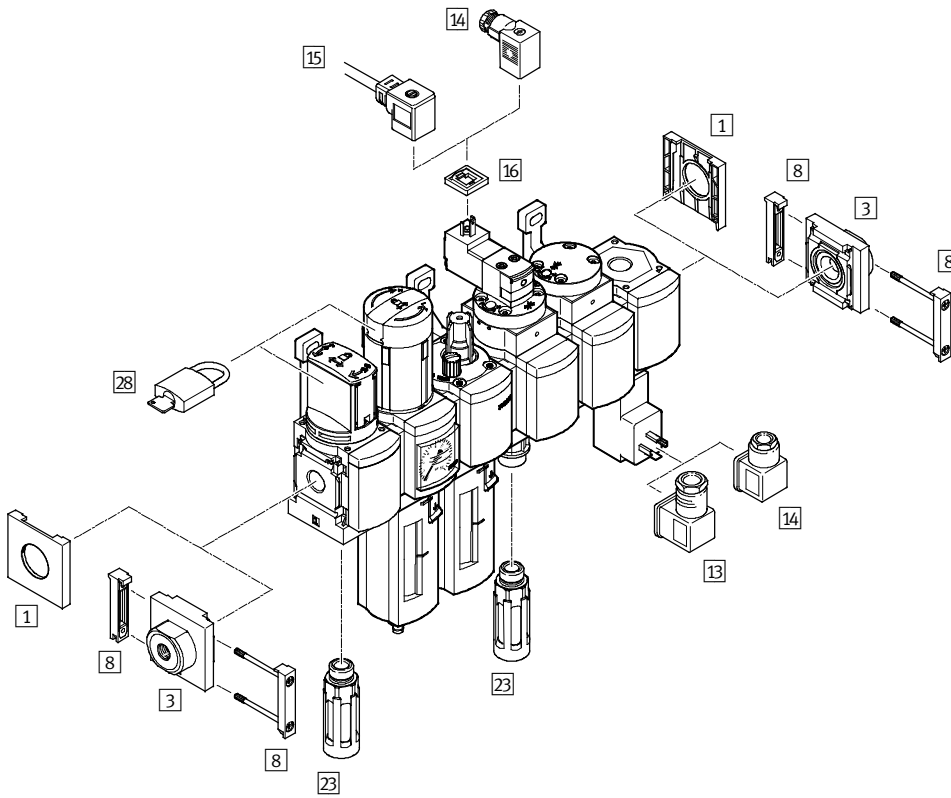

Note
The range of accessories depends on the service unit combination selected.

Accessories	→ Page/online
1 Cover cap MS4/6-END	889
3 Connecting plate MS4/6-AG...	889
8 Module connector MS4/6-MV	889
13 Angled plug socket PEV-1/4-WD-LED	890
14 Plug socket MSSD-C-4P for pressure switch PEV Plug socket MSSD-EB for on-off valve MS4/6-EE	890

Accessories	→ Page/online
15 Plug socket with cable KMEB	890
16 Illuminating seal MEB-LD	890
23 Silencer U	891
28 Padlock LRVS-D	891
- Special oil OFSW	891
- Filter cartridge MS4/6-LFP	892

Technical data

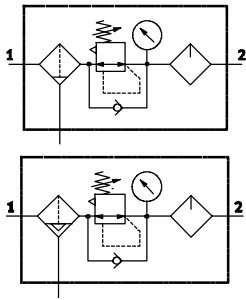

The following oils are recommended for Festo components:
Viscosity range to
ISO 3448, ISO class VG 32
32 mm²/s (= cSt) at 40 °C

- Festo special oil
→ 891
- ARAL Vitam GF 32
- BP Energol HLP 32
- ESSO Nuto H 32
- Mobil DTE 24
- Shell Tellus Oil DO 32

Download CAD data → www.festo.com

Technical data		MSB4		MSB6		
Size						
Pneumatic connection 1, 2		G ¹ / ₈	G ¹ / ₄	G ¹ / ₄	G ³ / ₈	G ¹ / ₂
Design		Filter regulator with pressure gauge and proportional standard mist lubricator				
Regulator function		With primary pressure compensation, with secondary venting, with return flow action, output pressure constant				
Type of mounting		Via accessories				
Mounting position		Vertical ±5°				
Grade of filtration	[µm]	40				
		5				
Air purity class at the output		Compressed air to ISO 8573-1:2010 [7:4:-] (grade of filtration 40 µm)				
		Compressed air to ISO 8573-1:2010 [6:4:-] (grade of filtration 5 µm)				
Bowl guard		Plastic bowl guard		Plastic bowl guard		
		-		Integrated as metal bowl		
Condensate drain		Manual rotary				
		Fully automatic				
Actuation security		Rotary knob with detent, can be locked using accessories				
Pressure regulation range	[bar]	0.3 ... 7				
		0.5 ... 12				
Pressure indication		Via pressure gauge				
Length/width/height	[mm]	57/80/222		77/124/303		

Standard nominal flow rate q _{NN}		MSB4		MSB6		
Size						
Pneumatic connection 1, 2		G ¹ / ₈	G ¹ / ₄	G ¹ / ₄	G ³ / ₈	G ¹ / ₂
Grade of filtration 40 µm						
q _{NN} [l/min] ¹⁾	With pressure regulation range 0.3 ... 7 bar	950	1,400	2,100	4,600	4,800
	With pressure regulation range 0.5 ... 12 bar	850	900	1,900	3,500	3,700
Grade of filtration 5 µm						
q _{NN} [l/min] ¹⁾	With pressure regulation range 0.3 ... 7 bar	900	1,300	2,000	4,400	4,600
	With pressure regulation range 0.5 ... 12 bar	800	850	1,700	3,400	3,600

1) Measured at p₁ = 10 bar and p₂ = 6 bar, Δp = 1 bar.

Operating conditions		Manual rotary		Fully automatic	
Condensate drain					
Size		MSB4	MSB6	MSB4	MSB6
Operating medium		Compressed air to ISO 8573-1:2010 [-:4:-]		Compressed air to ISO 8573-1:2010 [7:4:-]	
		Inert gases			
Note on operating/pilot medium		Lubricated operation possible (in which case lubricated operation will always be required)			
Operating pressure	[bar]	1.5 ... 14	1.5 ... 20	2 ... 12	2 ... 12
Ambient temperature	[°C]	-10 ... +60	-10 ... +60	+5 ... +60	+5 ... +60

Service units MSB-FRC, MS series

Technical data

Materials		
Housing		Die-cast aluminium
Rotary knob		PA, POM
Bowl	Plastic bowl guard	PC
	Metal bowl	Wrought aluminium alloy
Seals		NBR

Order code

MSB		-		-	
Series					
MSB	Service unit				
Size					
4	Grid dimension 40 mm				
6	Grid dimension 62 mm				
Pneumatic connection					
MSB4					
1/8	Thread G1/8				
1/4	Thread G1/4				
MSB6					
1/4	Thread G1/4				
3/8	Thread G3/8				
1/2	Thread G1/2				
Service unit consisting of:					
<ul style="list-style-type: none"> • Filter regulator with pressure gauge, lockable standard rotary knob • Lubricator 					

Pressure regulation range 0.3 ... 7 bar

Plastic bowl guard

FRC3:J7M1	Grade of filtration 5 µm, manual rotary condensate drain
FRC4:J8M1	Grade of filtration 5 µm, fully automatic condensate drain
FRC1:J5M1	Grade of filtration 40 µm, manual rotary condensate drain
FRC2:J6M1	Grade of filtration 40 µm, fully automatic condensate drain

Pressure regulation range 0.5 ... 12 bar

Plastic bowl guard

FRC7:J3M1	Grade of filtration 5 µm, manual rotary condensate drain
FRC8:J4M1	Grade of filtration 5 µm, fully automatic condensate drain
FRC5:J1M1	Grade of filtration 40 µm, manual rotary condensate drain
FRC6:J2M1	Grade of filtration 40 µm, fully automatic condensate drain

Metal bowl (MSB6 only)

FRC11:J9M2	Grade of filtration 5 µm, manual rotary condensate drain
FRC12:J10M2	Grade of filtration 5 µm, fully automatic condensate drain
FRC9:J11M2	Grade of filtration 40 µm, manual rotary condensate drain
FRC10:J12M2	Grade of filtration 40 µm, fully automatic condensate drain

Ordering – Product options

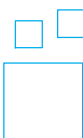

Configurable product

This product and all its options can be ordered using the configurator.

The configurator can be found under Products on the DVD or
 → www.festo.com/catalogue/...

Enter the type code in the search field.

Accessories – MS4/MS6

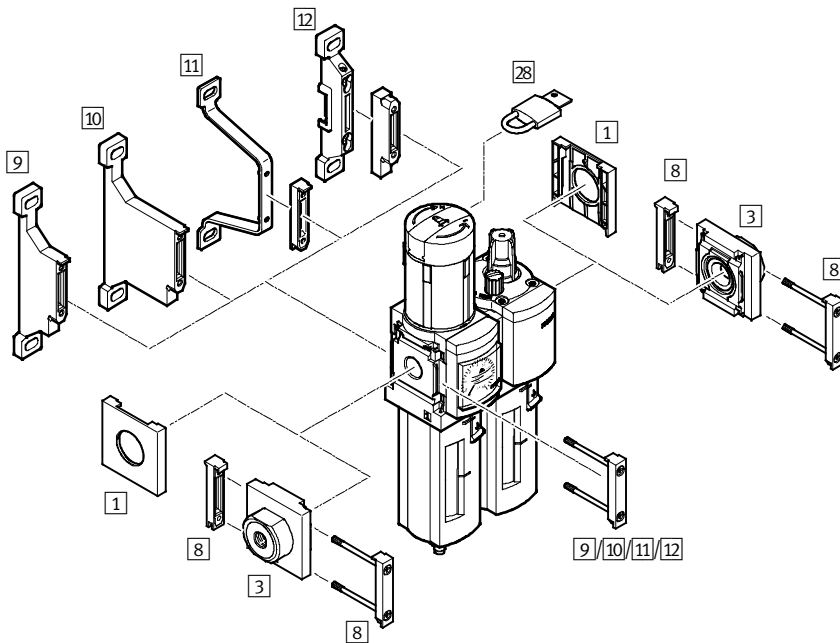

Accessories	→ Page/online
1 Cover cap MS4/6-END	889
3 Connecting plate MS4/6-AG...	889
8 Module connector MS4/6-MV	889
9 Mounting bracket MS4/6-WP	889
10 Mounting bracket MS4/6-WPB	889

Accessories	→ Page/online
11 Mounting bracket MS4/6-WPE	889
12 Mounting bracket MS4/6-WPM	889
28 Padlock LRVS-D	891
- Special oil OFSW	891
- Filter cartridge MS4/6-LFP	892

Filter regulators MS-LFR, MS series



- Good particle and condensate separation
- High flow rate
- 4 sizes:
MS4 – grid dimension 40 mm, MS6 – grid dimension 62 mm,
MS9 – grid dimension 90 mm, MS12 – grid dimension 124 mm
- Selected types in accordance with the ATEX Directive for explosive atmospheres → www.festo.com/catalogue/ex
- ★ Quick ordering of basic designs → 835

→ www.festo.com/catalogue/ms*-lfr

Product range overview

Size	Pneumatic connection	Product options																					
		D5	D6	D7	E	C	R	U	M	H	V	DI	VS	AG	A8	A4	AD...	BAR	LD	AS	Z		
4	1/8, 1/4	■	■	■	■	■	■	■	■	■	■	■	■	-	■	-1)	■	■	■	-1)	■	■	■
6	1/4, 3/8, 1/2	■	■	■	■	■	■	■	■	■	■	■	■	-	■	-1)	-	■	■	-1)	■	■	■
9	3/4, 1, G	■	■	■	■	■	-	■	■	■	■	■	■	■	■	-	■	■	■	■	-	■	■
12	G	-	■	■	■	■	-	■	■	■	-	■	-	■	-1)	-	■	-	-1)	■	■	■	■

1) MS pressure gauge with indicating range in bar included in the basic configuration by default.

Product options

1/8	Female thread G1/8	R	Plastic bowl with plastic bowl guard	AD1	Pressure sensor with LCD display, plug M8, 1 switching output PNP, 3-pin	BAR	Pressure gauge scale in bar
1/4	Female thread G1/4	U	Metal bowl	AD2	Pressure sensor with LCD display, plug M8, 1 switching output NPN, 3-pin	PSI	Pressure gauge scale in psi
3/8	Female thread G3/8	M	Manual condensate drain	AD3	Pressure sensor with LCD display, plug M12, 1 switching output PNP, 4-pin, analogue output 4 ... 20 mA	MPA	Pressure gauge scale in Mpa
1/2	Female thread G1/2	H	Semi-automatic condensate drain	AD4	Pressure sensor with LCD display, plug M12, 1 switching output NPN, 4-pin, analogue output 4 ... 20 mA	OS	Without secondary venting
3/4	Female thread G3/4	V	Fully automatic condensate drain	AD7	Pressure sensor with operational status indicator, plug M8, threshold value comparator, PNP, N/O contact	LD	Long rotary knob
1	Female thread G1	E2	External condensate drain, fully automatic, electric, 110 V AC, terminals	AD8	Pressure sensor with operational status indicator, plug M8, threshold value comparator, PNP, N/C contact	AS	Rotary knob with detent, can be locked using accessories
AGA	Connecting plate G1/8	E3	External condensate drain, fully automatic, electric, 230 V AC, terminals	AD9	Pressure sensor with operational status indicator, plug M8, window comparator, PNP, N/O contact	E11	Rotary knob with integrated locked
AGB	Connecting plate G1/4	E4	External condensate drain, fully automatic, electric, 24 V DC, terminals	AD10	Pressure sensor with operational status indicator, plug M8, window comparator, PNP, N/C contact	WR	Mounting bracket with knurled nut for regulator head
AGC	Connecting plate G3/8	DI	Directly actuated controller			WP	Mounting bracket
AGD	Connecting plate G1/2	VS	Cover plate			WPM	Mounting bracket
AGE	Connecting plate G3/4	AG	MS pressure gauge			WPB	Mounting bracket for large wall gap
AGF	Connecting plate G1	A8	Adapter plate for EN pressure gauge 1/8, without pressure gauge			WB	Mounting bracket
AGG	Connecting plate G1 1/4	A4	Adapter plate for EN pressure gauge 1/4, without pressure gauge			WBM	Mounting bracket
AGH	Connecting plate G1 1/2	RG	Integrated pressure gauge, red/green scale			EX4	EU certification (II 2GD in accordance with EU Directive 94/9/EC)
AGI	Connecting plate G2					UL1	UL certification (cULus, ordinary locations for Canada and USA)
G	Module without connecting thread, without connecting plate					Z	Flow direction from right to left
D5	Pressure regulation range 0.3 ... 4 bar						
D6	Pressure regulation range 0.3 ... 7 bar						
D7	Pressure regulation range 0.5 ... 12 bar						
D8	Pressure regulation range 0.5 ... 16 bar						
E	Grade of filtration 40 µm						
C	Grade of filtration 5 µm						

Technical data

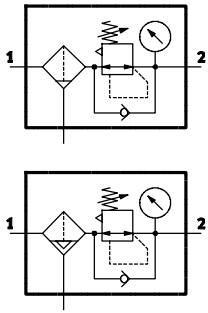

Download CAD data → www.festo.com

Technical data		Download CAD data → www.festo.com								
Size		MS4		MS6		MS9		MS12		
Pneumatic connection 1, 2		G1/8	G1/4	G1/4	G3/8	G1/2	G3/4	G1	- ¹⁾	- ¹⁾
Design		Filter regulator with/without pressure indicator						Pilot diaphragm regulator		
		Directly actuated diaphragm regulator						-		
Regulator function		With return flow action, with secondary venting, with primary pressure compensation								
Type of mounting		Via accessories								
		In-line installation								
Mounting position		Vertical ±5°								
Grade of filtration [µm]		40								
		5								
Air purity class at the output		Compressed air to ISO 8573-1:2010 [7:4:4] (grade of filtration 40 µm)								
		Compressed air to ISO 8573-1:2010 [6:4:4] (grade of filtration 5 µm)								
Bowl guard		Plastic bowl guard						-		
		Integrated as metal bowl								
Condensate drain		Manual rotary								
		Semi-automatic						-		
		Fully automatic								
Actuation security		Rotary knob with detent								
		Rotary knob with detent, can be locked using accessories								
Pressure regulation range [bar]	D5	0.5 ... 4						-		
	D6	0.5 ... 7						-		
	D7	0.5 ... 12 (0.5 ... 10 bar with pressure sensor AD...)						0.5 ... 12		
Pressure indication		Via pressure gauge for displaying output pressure								
	AD1/AD3	Via pressure sensor for displaying output pressure via LCD display and electrical output						-		
	AD7/AD9	Via pressure sensor for displaying output pressure via operational status indicator and electrical output						-		
Length [mm]	Standard	57		77		109		148		
	With cover plate VS	54		76		109		148		
	With adapter plate A8/A4	59		79		110		148		
	With pressure sensor AD1/AD3	83		103		-		-		
	With pressure sensor AD7/AD9	59		79		112		-		
Width [mm]		40		62		104		90		124
Height [mm] ²⁾	Plastic bowl guard	219 ... 223 ³⁾ + 25 ⁴⁾		300 ... 305 ³⁾ + 25 ⁴⁾		-		-		-
	Metal bowl	236 ... 240 ³⁾ + 68 ⁴⁾		309 ... 313 ³⁾ + 68 ⁴⁾		451 (444 ⁵⁾ + 150 ⁴⁾		572 + 250 ⁴⁾		-

- 1) Module without connecting thread/without connecting plate. The connecting plate must be ordered separately as an accessory → 889.
- 2) Height applies to filter regulator with detenting rotary knob, can be locked using accessories. The filter regulator without lockable rotary knob is approx. 9 mm smaller.
- 3) Value is dependent on the condensate drain.
- 4) Installation dimension for removing the filter bowl.
- 5) Value in brackets applies to the directly actuated filter regulator MS9-LFR...-DI.

Technical data

Standard nominal flow rate q_{NN}		MS4		MS6			MS9		MS12
Size		G1/8	G1/4	G1/4	G3/8	G1/2	G3/4	G1	-1)
Pneumatic connection 1, 2									-1)
Grade of filtration 40 μ m									
q_{NN} [l/min]	With pressure regulation range D5 ²⁾	1,100	1,900	2,200	6,000	7,200	19,000 ... 23,000 \pm 15% (8,000 ... 19,000 \pm 15%) ⁴⁾		-
	With pressure regulation range D6 ³⁾	1,000	1,700	2,800	5,700	6,200	15,000 ... 20,000 \pm 15% (13,000 ... 14,000 \pm 15%) ⁴⁾		12,000 ... 17,000
	With pressure regulation range D7 ³⁾	900	1,500	2,500	4,000	4,500	19,000 ... 20,000 \pm 15%		12,000 ... 17,000
Grade of filtration 5 μ m									
q_{NN} [l/min]	With pressure regulation range D5 ²⁾	900	1,800	2,000	5,500	6,900	16,000 ... 20,000 \pm 15% (8,000 ... 19,000 \pm 15%) ⁴⁾		-
	With pressure regulation range D6 ³⁾	900	1,500	2,700	5,000	5,600	13,000 ... 18,000 \pm 15%		11,000 ... 14,000
	With pressure regulation range D7 ³⁾	850	1,200	2,200	3,500	4,000	13,000 ... 18,000 \pm 15%		11,000 ... 14,000

1) Dependent on the connecting plate selected, must be ordered separately as an accessory → 889.

2) MS4/MS6: Measured at $p_1 = 10$ bar and $p_2 = 3$ bar, $\Delta p = 1$ bar.

MS9: Measured at $p_1 = 10$ bar and $p_2 = 4$ bar, $\Delta p = 1$ bar.

3) MS4/MS6/MS9: Measured at $p_1 = 10$ bar and $p_2 = 6$ bar, $\Delta p = 1$ bar.

MS12: Measured at $p_1 = 10$ bar and $p_2 = 6$ bar, $\Delta p = 0.5$ bar.

4) Value in brackets applies to the directly actuated filter regulator MS9-LFR...DI.

Operating conditions

Condensate drain	Manual rotary	Semi-automatic	Fully automatic
Size	MS4	MS6	MS4/MS6
Operating medium	Compressed air to ISO 8573-1:2010 [-:4:-]		Compressed air to ISO 8573-1:2010 [7:4:-]
	Inert gases		
Operating pressure [bar]	0.8 ... 14	0.8 ... 20	1.5 ... 12
Ambient temperature [°C]	-10 ... +60 (0 ... +50) ⁵⁾		+5 ... +60 (+5 ... +50) ⁵⁾

Condensate drain	Manual rotary	Semi-automatic	Fully automatic
Size	MS9	MS12	MS9
Operating medium	Compressed air to ISO 8573-1:2010 [-:4:-]		Compressed air to ISO 8573-1:2010 [7:4:-]
Operating pressure [bar]	1 ... 20	0.8 ... 20	1.5 ... 12
Ambient temperature [°C]	-10 ... +60 (0 ... +50) ⁵⁾		+5 ... +60 (+5 ... +50) ⁵⁾

5) Value in brackets applies to MS4/MS6/MS9-LFR with pressure sensor AD...

Materials

Housing	Die-cast aluminium
Rotary knob	PA, POM
Bowl	Plastic bowl guard
	Metal bowl
Seals	NBR

Order code – MS4

MS 4 – LFR – – – – – – – – – –

Series	
MS	Standard service unit

Size	
4	Grid dimension 40 mm

Type	
LFR	Filter regulator

Pneumatic connection	
1/8	Thread G1/8
1/4	Thread G1/4

Pressure regulation range	
D5	0.3 ... 4 bar
D6	0.3 ... 7 bar
D7	0.5 ... 12 bar

Grade of filtration	
E	40 µm
C	5 µm

Bowl guard	
R	Plastic bowl guard
U	Integrated as metal bowl

Condensate drain	
M	Manual rotary
H	Semi-automatic
V	Fully automatic

Pressure gauge alternatives		
–	With MS pressure gauge, bar	
VS	Cover plate	
A8	Adapter plate for EN pressure gauge 1/8	
A4	Adapter plate for EN pressure gauge 1/4	
AD1	Pressure sensor with display, plug M8, 1 switching output PNP, 3-pin	1
AD3	Pressure sensor with display, plug M12, 1 switching output PNP, 4-pin, analogue output 4 ... 20 mA	1
AD7	Pressure sensor without display, plug M8, threshold value comparator, PNP, N/O contact	1
AD9	Pressure sensor without display, plug M8, window comparator, PNP, N/O contact	1

Actuation security	
–	Rotary knob with detent
AS	Rotary knob with detent, can be locked using accessories

Flow direction	
–	From left to right
Z	From right to left

1 Measuring range max. 10 bar.

Filter regulators MS-LFR, MS series

FESTO

Order code – MS6

Series		MS	6	-	LFR	-	-	-	-	-	-	-
Series												
MS	Standard service unit											
Size												
6	Grid dimension 62 mm											
Type												
LFR	Filter regulator											
Pneumatic connection												
1/4	Thread G1/4											
3/8	Thread G3/8											
1/2	Thread G1/2											
Pressure regulation range												
D5	0.3 ... 4 bar											
D6	0.3 ... 7 bar											
D7	0.5 ... 12 bar											
Grade of filtration												
E	40 µm											
C	5 µm											
Bowl guard												
R	Plastic bowl guard											
U	Integrated as metal bowl											
Condensate drain												
M	Manual rotary											
H	Semi-automatic											
V	Fully automatic											
Pressure gauge alternatives												
-	With MS pressure gauge, bar											
VS	Cover plate											
A4	Adapter plate for EN pressure gauge 1/4											
AD1	Pressure sensor with LCD display, plug M8, 1 switching output PNP, 3-pin 1											
AD3	Pressure sensor with LCD display, plug M12, 1 switching output PNP, 4-pin, analogue output 4 ... 20 mA 1											
AD7	Pressure sensor with operational status indicator, plug M8, threshold value comparator, PNP, N/O contact 1											
AD9	Pressure sensor with operational status indicator, plug M8, window comparator, PNP, N/O contact 1											
Actuation security												
-	Rotary knob with detent											
AS	Rotary knob with detent, can be locked using accessories											
Flow direction												
-	From left to right											
Z	From right to left											

1 Measuring range max. 10 bar.

Order code – MS9

MS 9 – LFR – – – – U – – – –

Series	
MS	Standard service unit
Size	
9	Grid dimension 90 mm
Type	
LFR	Filter regulator
Pneumatic connection	
3/4	Thread G3/4
1	Thread G1
G	Module without connecting thread, without connecting plate Connecting plates → 889
Pressure regulation range	
D5	0.5 ... 4 bar
D6	0.5 ... 7 bar
D7	0.5 ... 12 bar
Grade of filtration	
E	40 µm
C	5 µm
Bowl guard	
U	Integrated as metal bowl
Condensate drain	
M	Manual rotary
H	Semi-automatic
V	Fully automatic
Regulator type	
–	Piloted
DI	Directly actuated 1
Pressure gauge/pressure gauge alternatives	
VS	Cover plate
AG	With MS pressure gauge
A4	Adapter plate for EN pressure gauge 1/4
AD7	Pressure sensor with operational status indicator, plug M8, threshold value comparator, PNP, N/O contact 2
AD9	Pressure sensor with operational status indicator, plug M8, window comparator, PNP, N/O contact 2
Alternative pressure gauge scale	
–	No pressure gauge scale 3
BAR	Bar 4
Actuation security	
–	Rotary knob with detent
AS	Rotary knob with detent, can be locked using accessories
Flow direction	
–	From left to right
Z	From right to left

1 Only with pressure regulation range D5, D6.

3 Not with MS pressure gauge AG.

4 Only with MS pressure gauge AG.

2 Measuring range max. 10 bar.

Filter regulators MS-LFR, MS series

Order code – MS12

MS 12 – LFR – G – – – U – – LD – –

Series	
MS	Standard service unit

Size	
12	Grid dimension 124 mm

Type	
LFR	Filter regulator

Pneumatic connection	
G	Module without connecting thread, without connecting plate Connecting plates → 889

Pressure regulation range	
D6	0.3 ... 7 bar
D7	0.5 ... 12 bar

Grade of filtration	
E	40 µm
C	5 µm

Bowl guard	
U	Integrated as metal bowl

Condensate drain	
M	Manual rotary
V	Fully automatic

Pressure gauge alternatives	
–	With MS pressure gauge, bar
VS	Cover plate
A4	Adapter plate for EN pressure gauge 1/4

Rotary knob	
LD	Long rotary knob

Actuation security	
–	Rotary knob with detent
AS	Rotary knob with detent, can be locked using accessories

Flow direction	
–	From left to right
Z	From right to left

12

Ordering – Product options

<input type="checkbox"/> <input type="checkbox"/> <input type="checkbox"/>	Configurable product	This product and all its options can be ordered using the configurator.	The configurator can be found under Products on the DVD or → www.festo.com/catalogue/...	Enter the type code in the search field.
--	-----------------------------	--	--	--

★ **Quick ordering**

Part No.	Type
MS4	
529144	MS4-LFR-1/4-D6-CRM-AS
529146	MS4-LFR-1/4-D6-CRV-AS
529148	MS4-LFR-1/4-D6-ERM-AS
529150	MS4-LFR-1/4-D6-ERV-AS
529152	MS4-LFR-1/4-D7-CRM-AS
529154	MS4-LFR-1/4-D7-CRV-AS
535718	MS4-LFR-1/4-D7-CUM-AS
535720	MS4-LFR-1/4-D7-CUV-AS
529156	MS4-LFR-1/4-D7-ERM-AS
529158	MS4-LFR-1/4-D7-ERV-AS
535724	MS4-LFR-1/4-D7-EUM-AS
535722	MS4-LFR-1/4-D7-EUV-AS

Part No.	Type
MS6	
529176	MS6-LFR-1/2-D6-CRM-AS
529178	MS6-LFR-1/2-D6-CRV-AS
529180	MS6-LFR-1/2-D6-ERM-AS
529182	MS6-LFR-1/2-D6-ERV-AS
529184	MS6-LFR-1/2-D7-CRM-AS
529186	MS6-LFR-1/2-D7-CRV-AS
530338	MS6-LFR-1/2-D7-CUM-AS
530340	MS6-LFR-1/2-D7-CUV-AS
529188	MS6-LFR-1/2-D7-ERM-AS
529190	MS6-LFR-1/2-D7-ERV-AS
529192	MS6-LFR-1/2-D7-EUM-AS
529194	MS6-LFR-1/2-D7-EUV-AS

Part No.	Type
MS9	
564110	MS9-LFR-G-D6-EUM-AG-BAR-AS
564111	MS9-LFR-G-D6-EUV-AG-BAR-AS
564118	MS9-LFR-G-D7-EUM-AG-BAR-AS
564119	MS9-LFR-G-D7-EUV-AG-BAR-AS

Accessories – MS4/MS6

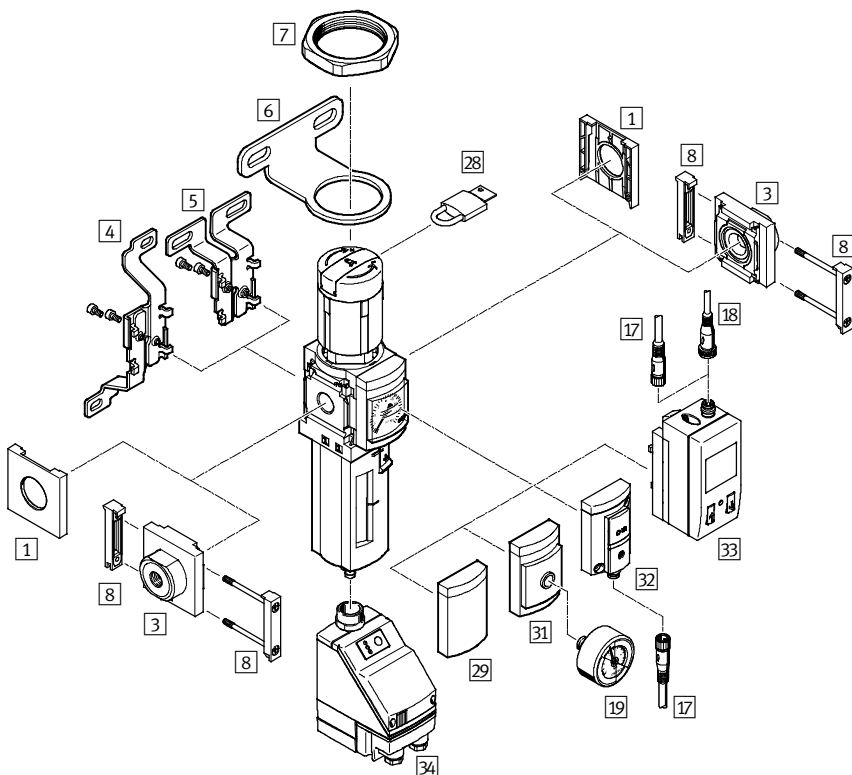

Accessories	→ Page/online
1 Cover cap MS4/6-END	889
3 Connecting plate MS4/6-AG...	889
4 Mounting bracket MS4/6-WB ¹⁾	889
5 Mounting bracket MS4-WBM ¹⁾	889
6 Mounting bracket MS4/6-WR ¹⁾	889
7 Hex nut MS4/6-WRS ¹⁾	889
8 Module connector MS4/6-MV	889
17 Connecting cable NEBU-M8...-LE3	890
18 Connecting cable NEBU-M12...-LE4	890
19 Pressure gauge MA	891
28 Padlock LRVS-D	891
29 Cover plate VS	831
31 Adapter plate A8/A4 for EN pressure gauge 1/8/1/4	831
32 Pressure sensor with operational status indicator AD7/AD9	831

Accessories	→ Page/online
33 Pressure sensor with LCD display AD1/AD3	831
34 Fully automatic condensate drain, electrically actuated (for MS6 only)	ms6-lfr
- Mounting plate MS4/6-AEND	889
- Mounting bracket MS4/6-WP ²⁾	889
- Mounting bracket MS4/6-WPB ²⁾	889
- Mounting bracket MS4/6-WPE ²⁾	889
- Mounting bracket MS4/6-WPM ²⁾	889
- Module connector MS4/6-RMV	892
- Module connector MS4-6-AMV	892
- Module connector MS6-9-ARMV	892
- Filter cartridge MS4/6-LFP	892
- Power supply module MS4/6-E-IPM	ms*-e-ipm*
- Branching module MS4/6-A-IPM	ms*-a*ipm*

2) Mounting and connecting component for combination or for individual device with connecting plate MS4/6-AG... [3] / with mounting plate MS4/6-AEND.

1) Mounting component for individual device.

Accessories – MS9

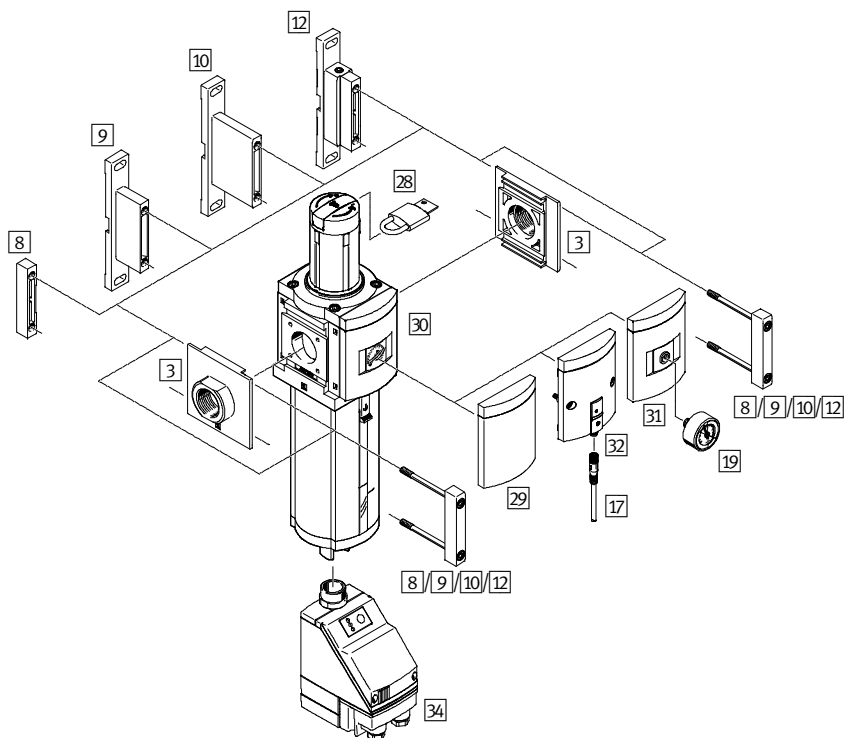

Accessories	→ Page/online
3 Connecting plate MS9-AG... ¹⁾	889
8 Module connector MS9-MV ¹⁾	889
9 Mounting bracket MS9-WP	889
10 Mounting bracket MS9-WPB	889
12 Mounting bracket MS9-WPM ¹⁾	889
17 Connecting cable NEBU-M8...-LE3	890
19 Pressure gauge MA	891
28 Padlock LRVS-D	891
29 Cover plate VS	833

Accessories	→ Page/online
30 MS pressure gauge AG	833
31 Adapter plate A4 for EN pressure gauge 1/4	833
32 Pressure sensor with operational status indicator AD7/AD9	833
34 Fully automatic condensate drain, electrically actuated	ms9-lfr
- Module connector MS9-RMV	892
- Module connector MS6-9-ARMV	892
- Module connector MS9-12-ARMV	892
- Filter cartridge MS9-LFP	892

1) Not suitable for individual devices with connecting thread G3/4 or G1.

Accessories – MS12

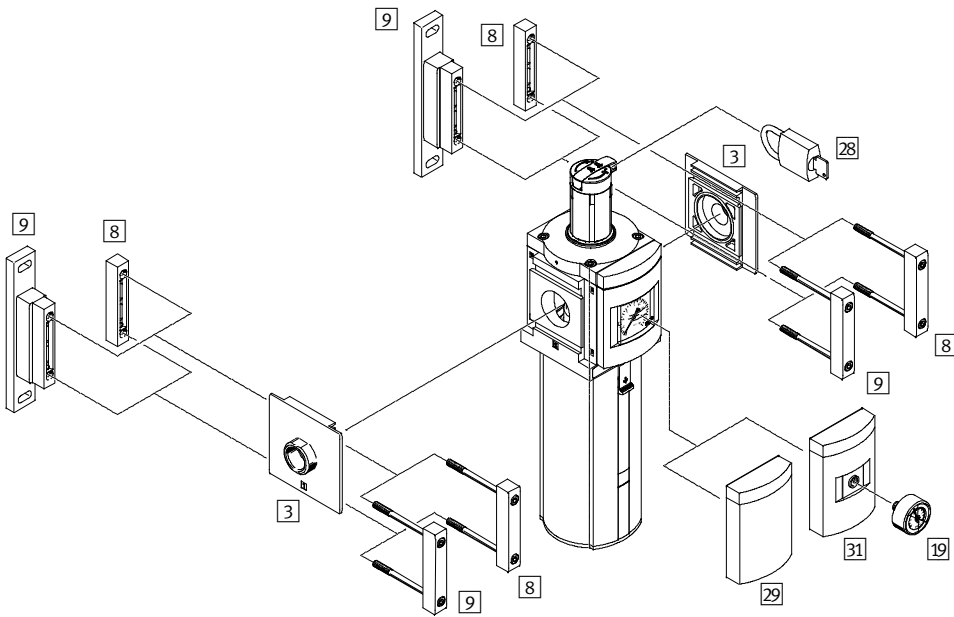

Accessories	→ Page/online
3 Connecting plate MS12-AG...	889
8 Module connector MS12-MV	889
9 Mounting bracket MS12-WP	889
19 Pressure gauge MA	891
28 Padlock LRVS-D	891
29 Cover plate VS	834

Accessories	→ Page/online
31 Adapter plate A4 for EN pressure gauge 1/4	834
- Module connector MS9-12-ARMV	892
- Filter cartridge MS12-LFP	892
- Fully automatic condensate drain, electrically actuated	ms12-lfr



- High flow rate with minimal pressure drop
- Suitable for front panel mounting
- 4 sizes:
MS4 – grid dimension 40 mm, MS6 – grid dimension 62 mm,
MS9 – grid dimension 90 mm, MS12 – grid dimension 124 mm
- Selected types in accordance with the ATEX Directive for explosive atmospheres → www.festo.com/catalogue/ex
- ★ Quick ordering of basic designs → 845

→ www.festo.com/catalogue/ms*-lr

Product range overview

Size	Pneumatic connection	Product options																
		D5	D6	D7	PO	PE6	DI	VS	AG	A8	A4	AD...	BAR	LD	DM1	DM2	AS	Z
4	1/8, 1/4	■	■	■	–	–	–	■	– ¹⁾	■	■	■	– ¹⁾	■	■	■	■	■
6	1/4, 3/8, 1/2	■	■	■	–	–	–	■	– ¹⁾	–	■	■	– ¹⁾	■	–	■	■	■
9	3/4, 1, G	■	■	■	■	–	■	■	■	–	■	■	■	–	–	–	■	■
12	G	–	■	■	■	■	–	■	– ¹⁾	–	■	–	– ¹⁾	■	–	–	■	■

1) MS pressure gauge with indicating range in bar included in the basic configuration by default.

Product options

1/8	Female thread G1/8	D8	Pressure regulation range 0.5 ... 16 bar, manually operated	AD3	Pressure sensor with LCD display, plug M12, 1 switching output PNP, 4-pin, analogue output 4 ... 20 mA	OS	Without secondary venting
1/4	Female thread G1/4	PO	Pressure regulation range 0.5 ... 16 bar, pneumatically actuated	AD4	Pressure sensor with LCD display, plug M12, 1 switching output NPN, 4-pin, analogue output 4 ... 20 mA	LD	Long rotary knob
3/8	Female thread G3/8	PE6	Pressure regulation range 0.15 ... 6 bar, electrically actuated	AD7	Pressure sensor with operational status indicator, plug M8, threshold value comparator, PNP, N/O contact	DM1	Rotary knob pressure gauge, small
1/2	Female thread G1/2	DI	Directly actuated controller	AD8	Pressure sensor with operational status indicator, plug M8, threshold value comparator, PNP, N/C contact	DM2	Rotary knob pressure gauge, large
3/4	Female thread G3/4	VS	Cover plate	AD9	Pressure sensor with operational status indicator, plug M8, window comparator, PNP, N/O contact	KD	Rotary knob underneath
1	Female thread G1	AG	MS pressure gauge	AD10	Pressure sensor with operational status indicator, plug M8, window comparator, PNP, N/C contact	AS	Rotary knob with detent, can be locked using accessories
AGA	Connecting plate G1/8	A8	Adapter plate for EN pressure gauge 1/8, without pressure gauge	BAR	Pressure gauge scale in bar	E11	Rotary knob with integrated lock
AGB	Connecting plate G1/4	A4	Adapter plate for EN pressure gauge 1/4, without pressure gauge	PSI	Pressure gauge scale in psi	WR	Mounting bracket with knurled nut for regulator head
AGC	Connecting plate G3/8	RG	Integrated pressure gauge, red/green scale	MPA	Pressure gauge scale in Mpa	WP	Mounting bracket
AGD	Connecting plate G1/2	AD1	Pressure sensor with LCD display, plug M8, 1 switching output PNP, 3-pin			WPM	Mounting bracket
AGE	Connecting plate G3/4	AD2	Pressure sensor with LCD display, plug M8, 1 switching output NPN, 3-pin			WPB	Mounting bracket for large wall gap
AGF	Connecting plate G1					WB	Mounting bracket
AGG	Connecting plate G1 1/4					WBM	Mounting bracket
AGH	Connecting plate G1 1/2					EX4	EU certification (II 2GD in accordance with EU Directive 94/9/EC)
AGI	Connecting plate G2					UL1	UL certification (cULus, ordinary locations for Canada and USA)
G	Module without connecting thread, without connecting plate					Z	Flow direction from right to left
D5	Pressure regulation range 0.3 ... 4 bar, manually operated						
D6	Pressure regulation range 0.3 ... 7 bar, manually operated						
D7	Pressure regulation range 0.5 ... 12 bar, manually operated						

Pressure regulators MS-LR, MS series

Technical data

Manually operated D5/D6/D7

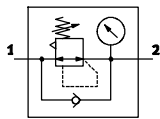

Pneumatically actuated PO

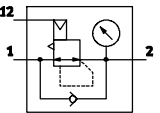

Electrically actuated PE6

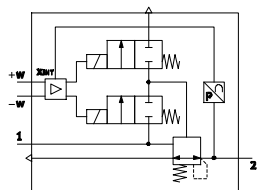

Technical data		Download CAD data → www.festo.com								
Size		MS4		MS6			MS9		MS12	
Pneumatic connection 1, 2		G1/8	G1/4	G1/4	G3/8	G1/2	G3/4	G1	[- ¹⁾	[- ¹⁾
Pilot air port 12 with pressure regulation range PO		-					G1/4		G1/4	
Design		Directly actuated diaphragm regulator					Piloted diaphragm regulator		Piloted diaphragm regulator (not PO)	
							Directly actuated diaphragm regulator		Diaphragm regulator (with PO)	
Regulator function		With return flow action, with secondary venting, with primary pressure compensation								
Type of mounting		Via accessories								
		In-line installation								
		Front panel mounting								-
Mounting position		Any								
Actuation security		Rotary knob with detent								
		Rotary knob with detent, can be locked using accessories								
Pressure regulation range/operation [bar]	D5	0.5 ... 4, manually operated ²⁾							-	
	D6	0.5 ... 7, manually operated ²⁾							-	
	D7	0.5 ... 12, manually operated (0.5 ... 10 bar with pressure sensor AD... ²⁾							-	
	PO ³⁾	-					0.5 ... 16, pneumatically actuated			
	PE6	-					0.15 ... 6, electrically actuated			
Pressure indicator		Via pressure gauge for displaying output pressure								
	DM1/DM2	Via pressure gauge in rotary knob for displaying output pressure					-			
	AD1/AD3	Via pressure sensor for displaying output pressure via LCD display and electrical output					-			
	AD7/AD9	Via pressure sensor for displaying output pressure via operational status indicator and electrical output							-	
Length [mm]	With MS pressure gauge	57		77			109		148	
	With cover plate VS	54		76			109		148	
	With adapter plate A8/A4	59		79			110		148	
	With pressure sensor AD1/AD3	83		103			-		-	
	With pressure sensor AD7/AD9	59		79			112		-	
Width [mm]	Standard	40		62			104		90	124
	With rotary knob pressure gauge DM2	60		62			-		-	
Height [mm]	With rotary knob with detent, can be locked using accessories AS ⁴⁾	125		189			225 (218) ⁵⁾		274	
	With rotary knob pressure gauge DM1	113		-			-		-	
	With rotary knob pressure gauge DM2	116		177			-		-	
	With pressure regulation range PO	-		-			120		181	
	With pressure regulation range PE6	-		-			-		235	

1) Module without connecting thread/without connecting plate. The connecting plate must be ordered separately as an accessory → 889.
 2) MS4: The pressure regulation range for pressure regulators with rotary knob pressure gauge DM... starts at 0.8 bar.
 3) Output pressure p2 corresponds roughly to the applied pilot pressure p12.
 4) The pressure regulator without lockable rotary knob is approx. 9 mm smaller.
 5) Value in brackets applies to the directly actuated pressure regulator MS9-LR...-DI.

Technical data

Standard nominal flow rate q_{NN}		MS4		MS6			MS9			MS12
Size		G1/8	G1/4	G1/4	G3/8	G1/2	G3/4	G1	- ¹⁾	- ¹⁾
q_{NN} [l/min]	With pressure regulation range D5 ²⁾	1,200	2,100	2,400	5,500	7,500	24,000 ... 33,000 ±15% (6,500 ... 18,500 ±15%) ⁵⁾			–
	With pressure regulation range D6 ³⁾	1,150	1,800	3,000	5,800	6,500	24,000 ... 28,000 ±15% (8,000 ... 9,000 ±15%) ⁵⁾			13,000 ... 22,000
	With pressure regulation range D7 ³⁾	1,000	1,700	2,700	4,500	5,500	24,000 ... 28,000 ±15%			13,000 ... 22,000
	With pressure regulation range PO ³⁾	–	–	–	–	–	23,000 ... 29,000 ±15%			13,000 ... 22,000
	With pressure regulation range PE6 ⁴⁾	–	–	–	–	–	–			12,000 ... 21,000

1) Dependent on the connecting plate selected, must be ordered separately as an accessory → 889.

2) MS4/MS6: Measured at $p_1 = 10$ bar and $p_2 = 3$ bar, $\Delta p = 1$ bar.

MS9: Measured at $p_1 = 10$ bar and $p_2 = 4$ bar, $\Delta p = 1$ bar.

3) MS4/MS6/MS9: Measured at $p_1 = 10$ bar and $p_2 = 6$ bar, $\Delta p = 1$ bar.

MS12: Measured at $p_1 = 10$ bar and $p_2 = 6$ bar, $\Delta p = 0.5$ bar.

4) MS12: Measured at $p_1 = 7$ bar and $p_2 = 6$ bar, $\Delta p = 0.5$ bar.

5) Value in brackets applies to the directly actuated pressure regulator MS9-LR-...-DI.

Electrical data (pressure regulation range/operation PE6 only)

Size		MS12
Operating voltage range	[V DC]	21.6 ... 26.4
Nominal operating voltage	[V DC]	24
Residual ripple	[%]	10
Analogue input signal range	[V]	0 ... 10
Max. current consumption	[A]	0.15
Max. electrical power consumption	[W]	3.6
Protection class		IP65

Operating conditions

Size		MS4	MS6	MS9	MS12
Operating medium		Compressed air to ISO 8573-1:2010 [7:4:4]			
		Inert gases			–
Note on operating/pilot medium		Lubricated operation possible (in which case lubricated operation will always be required)			
Operating pressure	[bar]	0.8 ... 14	0.8 ... 20	1 ... 20	0.8 ... 21 (1.15 ... 8) ⁷⁾
Ambient temperature	[°C]	-10 ... +60 (0 ... +50) ⁶⁾	-10 ... +60 (0 ... +50) ⁶⁾	-10 ... +60 (0 ... +50) ⁶⁾	-10 ... +60 (+10 ... +50) ⁷⁾

6) Value in brackets applies to MS4/MS6/MS9-LR with pressure sensor AD...

7) Value in brackets applies to MS12-LR with pressure regulation range/operation PE6.

Materials

Housing	Die-cast aluminium
Rotary knob	PA/POM
Seals	NBR

Order code – MS4

		MS	4	–	LR	–		–		–		–		–		–	
Series																	
MS	Standard service unit																
Size																	
4	Grid dimension 40 mm																
Type																	
LR	Pressure regulator																
Pneumatic connection																	
1/8	Thread G1/8																
1/4	Thread G1/4																
Pressure regulation range/operation																	
D5	0.3 ... 4 bar, manually operated																
D6	0.3 ... 7 bar, manually operated																
D7	0.5 ... 12 bar, manually operated																
Pressure gauge alternatives																	
–	With MS pressure gauge, bar															1	
VS	Cover plate																
A8	Adapter plate for EN pressure gauge 1/8																
A4	Adapter plate for EN pressure gauge 1/4																
AD1	Pressure sensor with LCD display, plug M8, 1 switching output PNP, 3-pin															2	
AD3	Pressure sensor with LCD display, plug M12, 1 switching output PNP, 4-pin, analogue output 4 ... 20 mA															2	
AD7	Pressure sensor with operational status indicator, plug M8, threshold value comparator, PNP, N/O contact															2	
AD9	Pressure sensor with operational status indicator, plug M8, window comparator, PNP, N/O contact															2	
Rotary knob alternative																	
–	Standard																
DM1	Rotary knob pressure gauge, small															3	
DM2	Rotary knob pressure gauge, large															4	
Actuation security																	
–	Rotary knob with detent																
AS	Rotary knob with detent, can be locked using accessories															1	
Flow direction																	
–	From left to right																
Z	From right to left																

1 Not with rotary knob alternative DM1 or DM2.

2 Not with rotary knob alternative DM2. Measuring range max. 10 bar.

3 Only with pressure gauge alternative VS, A8, A4, AD1, AD3, AD7 or AD9.

4 Only with pressure gauge alternative VS, A8 or A4.

Order code – MS6

	MS	6	LR						
Series									
MS	Standard service unit								
Size									
6	Grid dimension 62 mm								
Type									
LR	Pressure regulator								
Pneumatic connection									
1/4	Thread G1/4								
3/8	Thread G3/8								
1/2	Thread G1/2								
Pressure regulation range/operation									
D5	0.3 ... 4 bar, manually operated								
D6	0.3 ... 7 bar, manually operated								
D7	0.5 ... 12 bar, manually operated								
Pressure gauge alternatives									
–	With MS pressure gauge, bar								1
VS	Cover plate								
A4	Adapter plate for EN pressure gauge 1/4								
AD1	Pressure sensor with LCD display, plug M8, 1 switching output PNP, 3-pin								2
AD3	Pressure sensor with LCD display, plug M12, 1 switching output PNP, 4-pin, analogue output 4 ... 20 mA								2
AD7	Pressure sensor with operational status indicator, plug M8, threshold value comparator, PNP, N/O contact								2
AD9	Pressure sensor with operational status indicator, plug M8, window comparator, PNP, N/O contact								2
Rotary knob alternative									
–	Standard								
DM2	Rotary knob pressure gauge, large								3
Actuation security									
–	Rotary knob with detent								
AS	Rotary knob with detent, can be locked using accessories								1
Flow direction									
–	From left to right								
Z	From right to left								

1 Not with rotary knob alternative DM2.

2 Measuring range max. 10 bar.

3 Only with pressure gauge alternative VS, A4, AD1,

AD3, AD7 or AD9.

Pressure regulators MS-LR, MS series

Order code – MS9

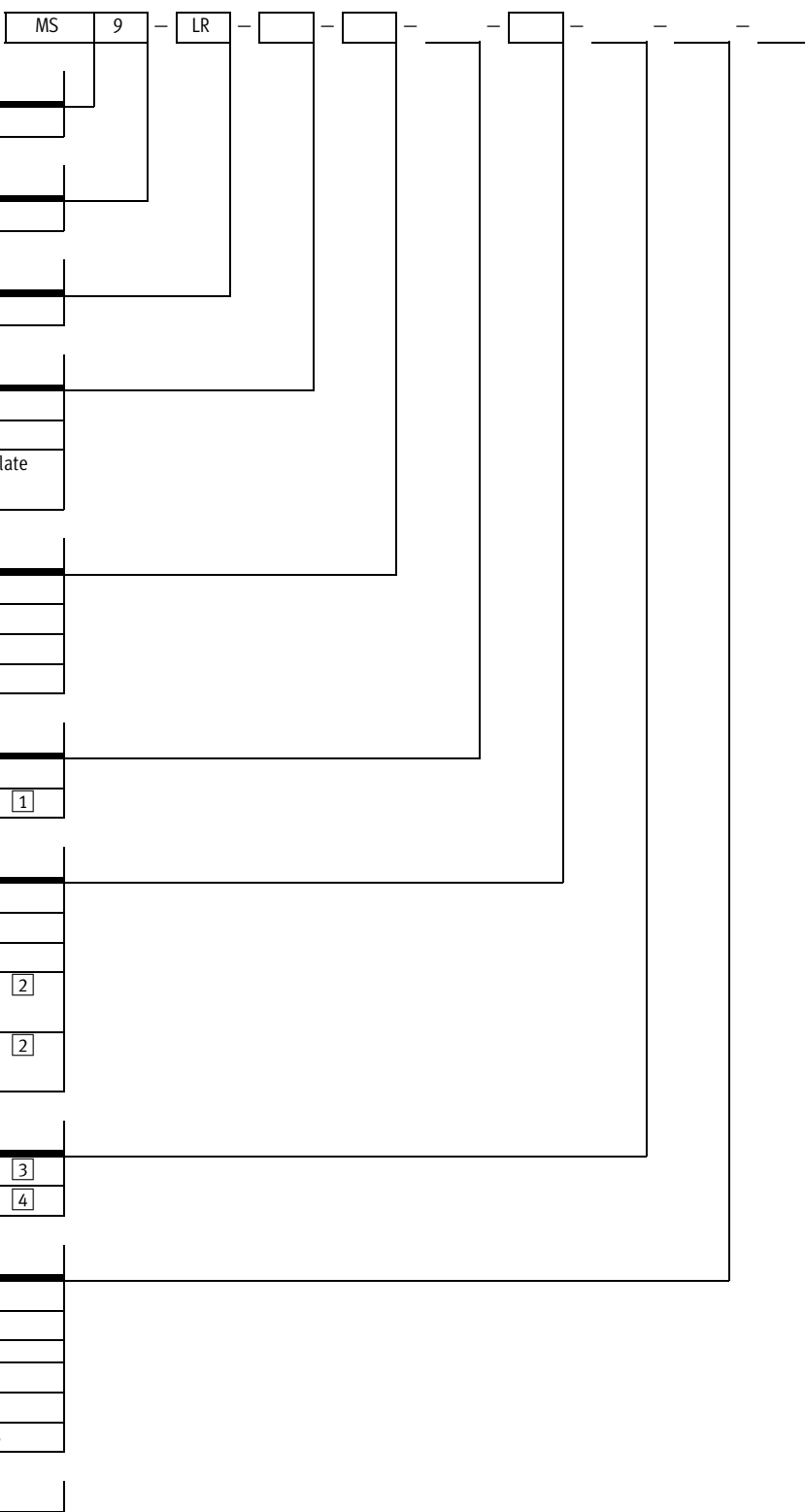

Series	
MS	Standard service unit

Size	
9	Grid dimension 90 mm

Type	
LR	Pressure regulator

Pneumatic connection	
3/4	Thread G3/4
1	Thread G1
G	Module without connecting thread, without connecting plate Connecting plates → 889

Pressure regulation range/operation	
D5	0.5 ... 4 bar, manually operated
D6	0.5 ... 7 bar, manually operated
D7	0.5 ... 12 bar, manually operated
PO	0.5 ... 16 bar, pneumatically actuated

Regulator type	
–	Piloted
DI	Directly actuated 1

Pressure gauge/pressure gauge alternatives	
AG	With MS pressure gauge
VS	Cover plate
A4	Adapter plate for EN pressure gauge 1/4
AD7	Pressure sensor with operational status indicator, plug 2 M8, threshold value comparator, PNP, N/O contact
AD9	Pressure sensor with operational status indicator, plug 2 M8, window comparator, PNP, N/O contact

Alternative pressure gauge scale	
–	No pressure gauge scale 3
BAR	Bar 4

Actuation security	
Pressure regulation range/operation PO	
–	None
Pressure regulation range/operation D5/D6/D7	
–	Rotary knob with detent
AS	Rotary knob with detent, can be locked using accessories

Flow direction	
–	From left to right
Z	From right to left

1 Only with pressure regulation range/operation D5, D6.

2 Measuring range max. 10 bar.
3 Not with MS pressure gauge AG.

4 Only with MS pressure gauge AG.

Order code – MS12

	MS	12	LR	G					
Series									
MS	Standard service unit								
Size									
12	Grid dimension 124 mm								
Type									
LR	Pressure regulator								
Pneumatic connection									
G	Module without connecting thread, without connecting plate Connecting plates → 889								
Pressure regulation range/operation									
D6	0.3 ... 7 bar, manually operated								
D7	0.5 ... 12 bar, manually operated								
PO	0.5 ... 16 bar, pneumatically actuated								
PE6	0.15 ... 6 bar, electrically actuated								
Pressure gauge alternatives									
–	With MS pressure gauge, bar								
VS	Cover plate								
A4	Adapter plate for EN pressure gauge ¼								
Rotary knob									
Pressure regulation range/operation PO/PE6									
–	None								
Pressure regulation range/operation D6/D7									
LD	Long rotary knob								
Actuation security									
Pressure regulation range/operation PO/PE6									
–	None								
Pressure regulation range/operation D6/D7									
–	Rotary knob with detent								
AS	Rotary knob with detent, can be locked using accessories								
Flow direction									
–	From left to right								
Z	From right to left								

Ordering – Product options

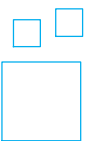

Configurable product

This product and all its options can be ordered using the configurator.

The configurator can be found under Products on the DVD or
→ www.festo.com/catalogue/...

Enter the type code in the search field.

★ Quick ordering

Part No.	Type
MS4	
529415	MS4-LR-¼-D5-AS
529417	MS4-LR-¼-D6-AS
529419	MS4-LR-¼-D7-AS

Part No.	Type
MS6	
529989	MS6-LR-½-D5-AS
529991	MS6-LR-½-D6-AS
529993	MS6-LR-½-D7-AS

Part No.	Type
MS9	
564136	MS9-LR-G-D6-AG-BAR-AS
564138	MS9-LR-G-D7-AG-BAR-AS

Pressure regulators MS-LR, MS series

Accessories – MS4/MS6

With standard rotary knob

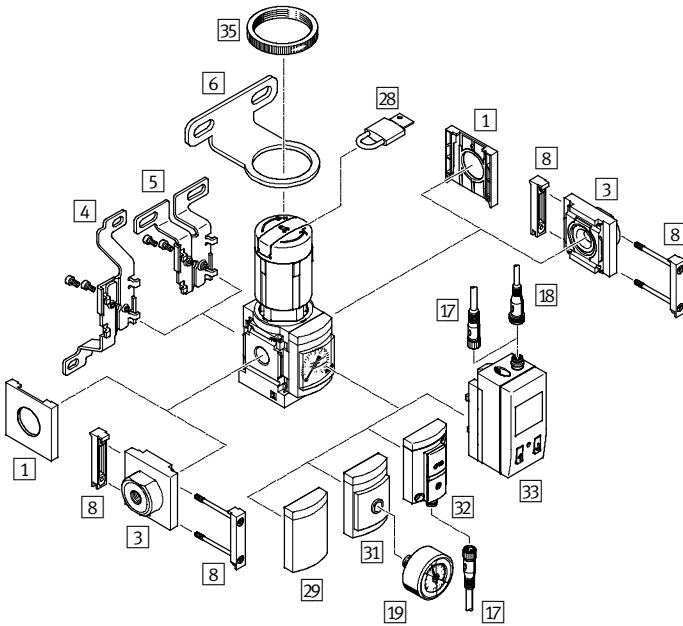

With rotary knob pressure gauge DM1 (MS4 only) or DM2 (MS6 only)

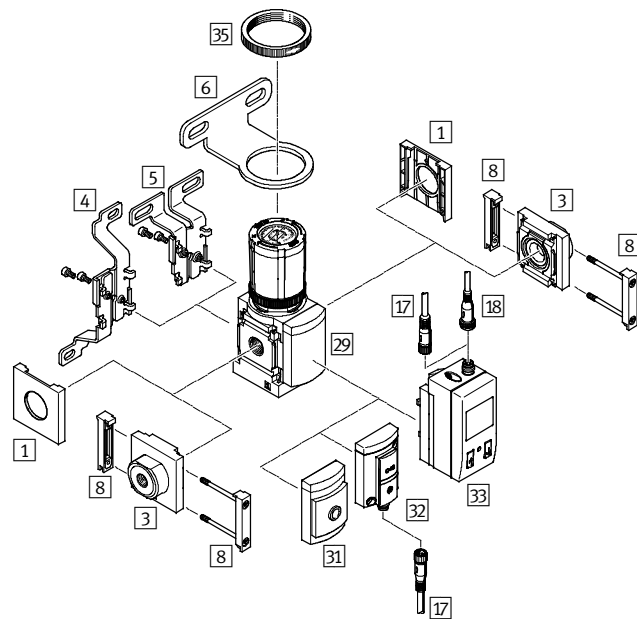

With rotary knob pressure gauge DM2 (MS4 only)

Note
Due to the protruding rotary knob, only a distributor block MS4-FRM-FRZ or a branching module MS4-FRM can be connected as a directly adjacent service unit component.

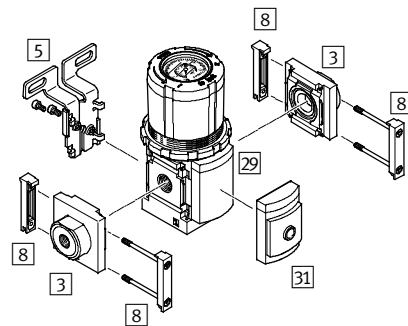

12

Accessories	→ Page/online
1 Cover cap MS4/6-END	889
3 Connecting plate MS4/6-AG...	889
4 Mounting bracket MS4/6-WB ¹⁾	889
5 Mounting bracket MS4-WBM ¹⁾	889
6 Mounting bracket MS4/6-WR ¹⁾	889
8 Module connector MS4/6-MV	889
17 Connecting cable NEBU-M8...-LE3	890
18 Connecting cable NEBU-M12...-LE4	890
19 Pressure gauge MA	891
28 Padlock LRVS-D	891
29 Cover plate VS	842
31 Adapter plate A8/A4 for EN pressure gauge 1/8/1/4	842
32 Pressure sensor with operational status indicator AD7/AD9	842

Accessories	→ Page/online
33 Pressure sensor with LCD display AD1/AD3	842
35 Knurled nut MS-LR (included in the scope of delivery)	-
- Mounting plate MS4/6-AEND	889
- Mounting bracket MS4/6-WP ²⁾	889
- Mounting bracket MS4/6-WPB ²⁾	889
- Mounting bracket MS4/6-WPE ²⁾	889
- Mounting bracket MS4/6-WPM ²⁾	889
- Module connector MS4/6-RMV	892
- Module connector MS4/6-AMV	892
- Module connector MS6-9-ARMV	892
- Power supply module MS4/6-E-IPM	ms*-e-ipm*
- Branching module MS4/6-A-IPM	ms*-a-ipm*

2) Mounting and connecting component for combination or for individual device with connecting plate MS4/6-AG... [3]/with mounting plate MS4/6-AEND.

1) Mounting component for individual device.

Accessories – MS9

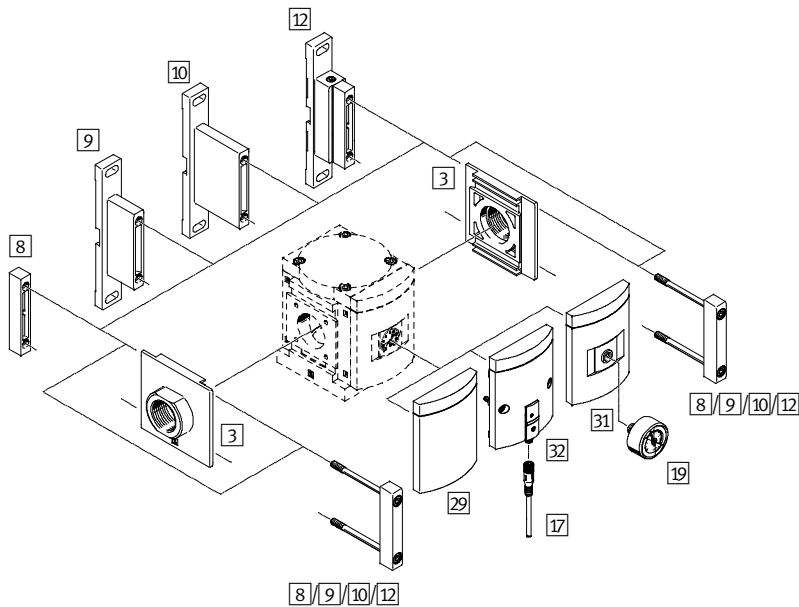

Manually operated D5/D6/D7

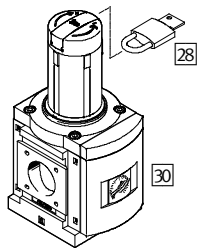

Pneumatically actuated P0

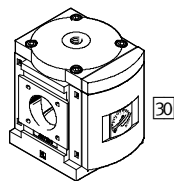

Accessories	→ Page/online
3 Connecting plate MS9-AG... ¹⁾	889
8 Module connector MS9-MV ¹⁾	889
9 Mounting bracket MS9-WP	889
10 Mounting bracket MS9-WPB	889
12 Mounting bracket MS9-WPM ¹⁾	889
17 Connecting cable NEBU-M8...-LE3	890
19 Pressure gauge MA	891
28 Padlock LRVS-D	891

Accessories	→ Page/online
29 Cover plate VS	844
30 MS pressure gauge AG	844
31 Adapter plate A4 for EN pressure gauge 1/4	844
32 Pressure sensor with operational status indicator AD7/AD9	844
- Module connector MS9-RMV	892
- Module connector MS6-9-ARMV	892
- Module connector MS9-12-ARMV	892

1) Not suitable for individual devices with connecting thread G3/4 or G1.

Accessories – MS12

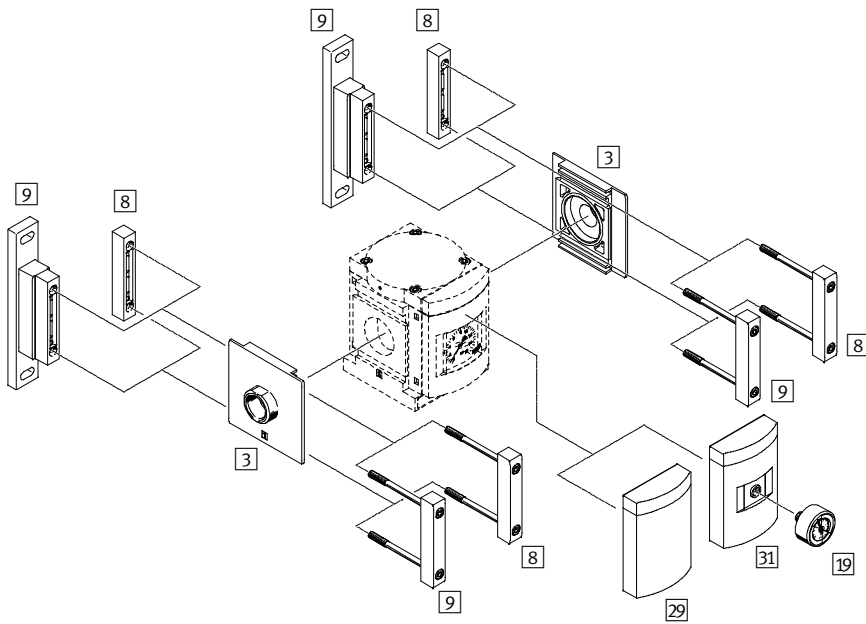

Manually operated D6/D7

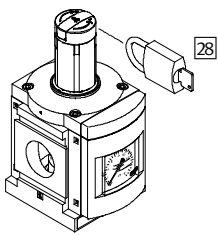

Pneumatically actuated PO

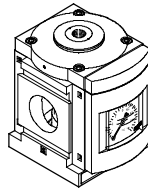

Electrically actuated PE6

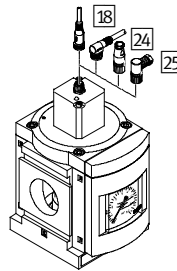

Accessories	→ Page/online
3 Connecting plate MS12-AG...	889
8 Module connector MS12-MV	889
9 Mounting bracket MS12-WP	889
18 Connecting cable NEBU-M12...-LE4	890
19 Pressure gauge MA	891
24 Sensor socket SIE-GD	891

Accessories	→ Page/online
25 Angled socket SIE-WD	891
28 Padlock LRVS-D	891
29 Cover plate VS	845
31 Adapter plate A4 for EN pressure gauge 1/4	845
- Module connector MS9-12-ARMV	892



- For manifold assembly with through air supply
- For configuring a regulator manifold with independent pressure regulation ranges
- 2 sizes:
MS4 – grid dimension 40 mm, MS6 – grid dimension 62 mm

→ www.festo.com/catalogue/ms*-lrb

Product range overview

Size	Pneumatic connection	Product options														
		D5	D6	D7	VS	A8	A4	AD...	DM1	DM2	AS	BC	BD	BE	Z	
4	1/4	■	■	■	■	■	■	■	■	■	–	■	■	■	–	■
6	1/2	■	■	■	■	–	■	■	–	■	■	–	■	■	■	■

Product options

1/4	Female thread G1/4	A4	Adapter plate for EN pressure gauge 1/4, without pressure gauge	AD7	Pressure sensor with operational status indicator, plug M8, threshold value comparator, PNP, N/O contact	KD	Rotary knob underneath
1/2	Female thread G1/2	RG	Integrated pressure gauge, red/green scale	AD8	Pressure sensor with operational status indicator, plug M8, threshold value comparator, PNP, N/C contact	AS	Rotary knob with detent, can be locked using accessories
AGA	Connecting plate G1/8	AD1	Pressure sensor with LCD display, plug M8, 1 switching output PNP, 3-pin	AD9	Pressure sensor with operational status indicator, plug M8, window comparator, PNP, N/O contact	E11	Rotary knob with integrated lock
AGB	Connecting plate G1/4	AD2	Pressure sensor with LCD display, plug M8, 1 switching output NPN, 3-pin	AD10	Pressure sensor with operational status indicator, plug M8, window comparator, PNP, N/C contact	BC	Angled outlet block QS-6
AGC	Connecting plate G3/8	AD3	Pressure sensor with LCD display, plug M12, 1 switching output PNP, 4-pin, analogue output	PSI	Pressure gauge scale in psi	BD	Angled outlet block QS-8
AGD	Connecting plate G1/2	AD4	Pressure sensor with LCD display, plug M12, 1 switching output NPN, 4-pin, analogue output	MPA	Pressure gauge scale in Mpa	BE	Angled outlet block QS-10
AGE	Connecting plate G3/4			OS	Without secondary venting	WR	Mounting bracket with knurled nut for regulator head
D5	Pressure regulation range 0.3 ... 4 bar, manually operated			LD	Long rotary knob	WP	Mounting bracket
D6	Pressure regulation range 0.3 ... 7 bar, manually operated			DM1	Rotary knob pressure gauge, small	WPM	Mounting bracket
D7	Pressure regulation range 0.5 ... 12 bar, manually operated			DM2	Rotary knob pressure gauge, large	WPB	Mounting bracket for large wall gap
D8	Pressure regulation range 0.5 ... 16 bar, manually operated					WB	Mounting bracket
VS	Cover plate					WBM	Mounting bracket
A8	Adapter plate for EN pressure gauge 1/8, without pressure gauge					UL1	UL certification (cULus, ordinary locations for Canada and USA)
						Z	Pressure output to front

Technical data

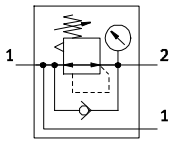

Technical data		MS4		MS6	
Size		MS4		MS6	
Pneumatic connection 1		G $\frac{1}{4}$		G $\frac{1}{2}$	
Pneumatic connection 2		G $\frac{1}{4}$		G $\frac{1}{2}$	
		QS-6 (angled outlet block)		QS-8 (angled outlet block)	
		QS-8 (angled outlet block)		QS-10 (angled outlet block)	
Design		Directly actuated diaphragm regulator with through compressed air supply			
Regulator function		With return flow action, with secondary venting, with primary pressure compensation			
Type of mounting		Via accessories			
		In-line installation			
		Front panel mounting			
Mounting position		Any			
Actuation security		Rotary knob with detent			
		Rotary knob with detent, can be locked using accessories			
Pressure regulation range/operation [bar]		D5	0.3 ... 4, manually operated ¹⁾		
		D6	0.3 ... 7, manually operated ¹⁾		
		D7	0.5 ... 12, manually operated (0.5 ... 10 bar with pressure sensor AD... ¹⁾		
Pressure indicator		Via pressure gauge for displaying output pressure			
		DM1/DM2	Via pressure gauge in rotary knob for displaying output pressure		
		AD1/AD3	Via pressure sensor for displaying output pressure via LCD display and electrical output		
		AD7/AD9	Via pressure sensor for displaying output pressure via operational status indicator and electrical output		
Length [mm]	With MS pressure gauge	57 (78) ²⁾		77 (100) ²⁾	
	With cover plate VS	54 (75) ²⁾		76 (99) ²⁾	
	With adapter plate A8/A4	59 (80) ²⁾		79 (102) ²⁾	
	With pressure sensor AD1/AD3	83 (104) ²⁾		103 (126) ²⁾	
	With pressure sensor AD7/AD9	59 (80) ²⁾		79 (102) ²⁾	
Width [mm]		40		62	
Height [mm]	With rotary knob with detent, can be locked using accessories AS ³⁾	125		189	
	With rotary knob pressure gauge DM1	115		–	
	With rotary knob pressure gauge DM2	–		177	

1) MS4: The pressure regulation range for pressure regulators with rotary knob pressure gauge DM1 starts at 0.8 bar.

2) Value in brackets with angled outlet block.

3) The pressure regulator without lockable rotary knob is approx. 9 mm smaller.

Standard nominal flow rate q_{nN}

Size		MS4			MS6		
		Standard	Angled outlet block		Standard	Angled outlet block	
			QS-6	QS-8		QS-8	QS-10
q_{nN} [l/min]	With pressure regulation range D5 ⁴⁾	1,900	300	650	7,300	600	750
	With pressure regulation range D6 ⁵⁾	1,700	350	840	6,300	880	1,000
	With pressure regulation range D7 ⁵⁾	1,500 ⁶⁾	350	640	5,500	800	950

4) Measured at $p_1 = 10$ bar and $p_2 = 3$ bar, $\Delta p = 1$ bar.

5) Measured at $p_1 = 10$ bar and $p_2 = 6$ bar, $\Delta p = 1$ bar.

6) $q_{nN} = 800$ l/min, $q_{n\max} = 2,200$ l/min with rotary knob pressure gauge DM1.

Technical data

Operating conditions		MS4	MS6
Size			
Operating medium		Compressed air to ISO 8573-1:2010 [7:4:4] Inert gases	
Note on operating/pilot medium		Lubricated operation possible (in which case lubricated operation will always be required)	
Operating pressure	[bar]	0.8 ... 14	0.8 ... 20
Ambient temperature	[°C]	-10 ... +60 (0 ... +50) ¹⁾	-10 ... +60 (0 ... +50) ¹⁾

1) Value in brackets applies to MS4/MS6-LRB with pressure sensor AD...

Materials	
Housing	Die-cast aluminium
Rotary knob	PA/POM
Seals	NBR

Ordering – Product options



Configurable product

This product and all its options can be ordered using the configurator.

The configurator can be found under Products on the DVD or
[→ www.festo.com/catalogue/...](http://www.festo.com/catalogue/...)

Enter the type code in the search field.

Pressure regulators MS-LRB, MS series

FESTO

Order code – MS4

		MS	4	LRB	1/4					
Series										
MS	Standard service unit									
Size										
4	Grid dimension 40 mm									
Type										
LRB	Pressure regulator									
Pneumatic connection										
1/4	Thread G1/4									
Pressure regulation range/operation										
D5	0.3 ... 4 bar, manually operated									
D6	0.3 ... 7 bar, manually operated									
D7	0.5 ... 12 bar, manually operated									
Pressure gauge alternatives										
–	With MS pressure gauge, bar									
VS	Cover plate									
A8	Adapter plate for EN pressure gauge 1/8									
A4	Adapter plate for EN pressure gauge 1/4									
AD1	Pressure sensor with LCD display, plug M8, 1 switching output PNP, 3-pin									
AD3	Pressure sensor with LCD display, plug M12, 1 switching output PNP, 4-pin, analogue output 4 ... 20 mA									
AD7	Pressure sensor with operational status indicator, plug M8, threshold value comparator, PNP, N/O contact									
AD9	Pressure sensor with operational status indicator, plug M8, window comparator, PNP, N/O contact									
Rotary knob alternative										
–	Standard									
DM1	Rotary knob pressure gauge, small									
Actuation security										
–	Rotary knob with detent									
AS	Rotary knob with detent, can be locked using accessories									
Pressure output										
–	No angled outlet block									
BC	Angled outlet block QS-6									
BD	Angled outlet block QS-8									
Alternative flow direction										
–	Pressure output to the rear									
Z	Pressure output to the front									

1 Not with rotary knob alternative DM1.

2 Must be selected if alternative flow direction Z is selected without pressure output BC, BD.

3 Not in combination with alternative flow direction Z.

4 Measuring range max. 10 bar.

5 In combination with alternative flow direction Z only with pressure output BC, BD.

6 Only with pressure gauge alternative VS, A8, A4, AD1, AD3, AD7 or AD9.

Pressure regulators MS-LRB, MS series

Accessories – MS4/MS6

Pressure output to the rear

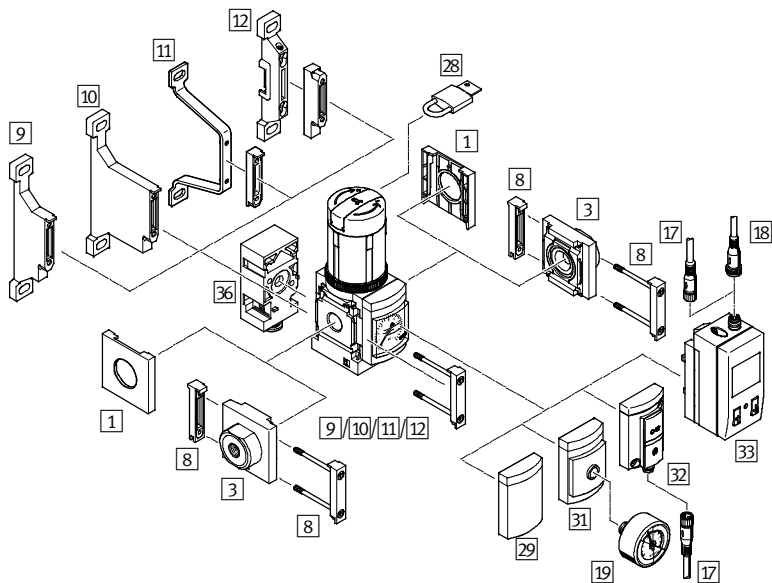

Pressure output to the front (alternative flow direction Z)

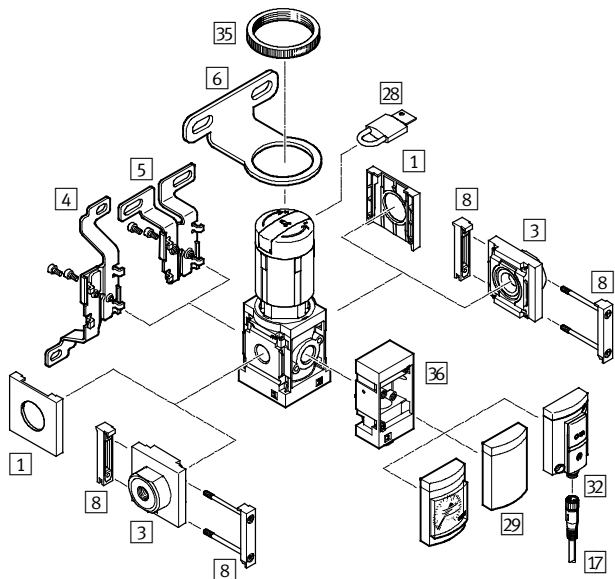

Accessories	→ Page/online
1 Cover cap MS4/6-END	889
3 Connecting plate MS4/6-AG...	889
4 Mounting bracket MS4/6-WB ¹⁾	889
5 Mounting bracket MS4/6-WBM ¹⁾	889
6 Mounting bracket MS4/6-WR ¹⁾	889
8 Module connector MS4/6-MV	889
9 Mounting bracket MS4/6-WP ²⁾⁴⁾	889
10 Mounting bracket MS4/6-WPB ³⁾⁴⁾	889
11 Mounting bracket MS4/6-WPE ³⁾⁴⁾	889
12 Mounting bracket MS4/6-WPM ⁴⁾	889
17 Connecting cable NEBU-M8...-LE3	890
18 Connecting cable NEBU-M12...-LE4	890
19 Pressure gauge MA	891

1) Mounting component for individual device.
 2) Only with alternative flow direction Z and/or only with pressure output BC, BD, BE.

Accessories	→ Page/online
28 Padlock LRVS-D	891
29 Cover plate VS	852
31 Adapter plate A8/A4 for EN pressure gauge 1/8/1/4	852
32 Pressure sensor with operational status indicator AD7/AD9	852
33 Pressure sensor with LCD display AD1/AD3	852
35 Knurled nut MS-LR (included in the scope of delivery)	-
36 Angled outlet block B...	852
- Mounting plate MS4/6-AEND	889
- Module connector MS4/6-RMV	892
- Module connector MS4/6-AMV	892
- Module connector MS6-9-ARMV	892
- Power supply module MS4/6-E-IPM	ms*-e-ipm*
- Branching module MS4/6-A-IPM	ms*-a*ipm*

3) Not in combination with alternative flow direction Z and pressure output BC, BD, BE.
 4) Mounting and connecting component for combination or for individual device with connecting plate MS4/6-AG... [3] with mounting plate MS4/6-AEND.



- Manually operated on-off valve for pressurising and exhausting pneumatic systems
- 4 sizes:
MS4 – grid dimension 40 mm, MS6 – grid dimension 62 mm,
MS9 – grid dimension 90 mm, MS12 – grid dimension 124 mm
- Selected types in accordance with the ATEX Directive for explosive atmospheres → www.festo.com/catalogue/ex
- ★ Quick ordering of basic designs → 859

→ www.festo.com/catalogue/ms*-em

Product range overview

Size	Pneumatic connection	Product options								
		S	VS	AG	A8	A4	AD...	BAR	2	Z
4	1/8, 1/4	■	-1)	■	■	■	■	-	-	■
6	1/4, 3/8, 1/2	■	-1)	■	-	■	■	-	-	■
9	3/4, 1, G	■	■	■	-	■	-	■	■	■
12	G	■	-1)	■	-	■	-	-	-	■

1) Cover plate included in the basic configuration by default.

Product options

1/8	Female thread G1/8	S	Silencer	AD4	Pressure sensor with LCD display, plug M12, 1 switching output NPN, 4-pin, analogue output 4 ... 20 mA	BAR	Pressure gauge scale in bar
1/4	Female thread G1/4	VS	Cover plate	AD7	Pressure sensor with operational status indicator, plug M8, threshold value comparator, PNP, N/O contact	PSI	Pressure gauge scale in psi
3/8	Female thread G3/8	AG	MS pressure gauge	AD8	Pressure sensor with operational status indicator, plug M8, threshold value comparator, PNP, N/C contact	MPA	Pressure gauge scale in Mpa
1/2	Female thread G1/2	A8	Adapter plate for EN pressure gauge 1/8, without pressure gauge	AD9	Pressure sensor with operational status indicator, plug M8, window comparator, PNP, N/O contact	2	2/2-way valve
3/4	Female thread G3/4	A4	Adapter plate for EN pressure gauge 1/4, without pressure gauge	AD10	Pressure sensor with operational status indicator, plug M8, window comparator, PNP, N/C contact	WP	Mounting bracket
1	Female thread G1	RG	Integrated pressure gauge, red/green scale			WPM	Mounting bracket
AGA	Connecting plate G1/8	AD1	Pressure sensor with LCD display, plug M8, 1 switching output PNP, 3-pin			WPB	Mounting bracket for large wall gap
AGB	Connecting plate G1/4	AD2	Pressure sensor with LCD display, plug M8, 1 switching output NPN, 3-pin			WB	Mounting bracket
AGC	Connecting plate G3/8	AD3	Pressure sensor with LCD display, plug M12, 1 switching output PNP, 4-pin, analogue output 4 ... 20 mA			WBM	Mounting bracket
AGD	Connecting plate G1/2					EX4	EU certification (II 2GD in accordance with EU Directive 94/9/EC)
AGE	Connecting plate G3/4					UL1	UL certification (cULus, ordinary locations for Canada and USA)
AGF	Connecting plate G1					Z	Flow direction from right to left
AGG	Connecting plate G1 1/4						
AGH	Connecting plate G1 1/2						
AGI	Connecting plate G2						
G	Module without connecting thread, without connecting plate						

On-off valves MS-EM, MS series

FESTO

Technical data

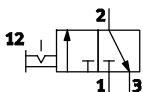
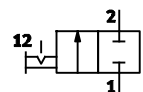

Technical data		Download CAD data → www.festo.com									
Size		MS4		MS6			MS9		MS12		
Pneumatic connection 1, 2		G $\frac{1}{8}$	G $\frac{1}{4}$	G $\frac{1}{4}$	G $\frac{3}{8}$	G $\frac{1}{2}$	G $\frac{3}{4}$	G1	- ¹⁾	- ¹⁾	
Pneumatic connection 3		G $\frac{1}{4}$		G $\frac{1}{2}$			G1		G1		
Design		Rotary slide valve					Piston spool valve				
Type of mounting		Via accessories In-line installation									
Mounting position		Any									
Actuation type		Manual									
Valve function		-					2/2-way valve, double sol.		-		
		3/2-way valve, double solenoid									
Exhaust function		No flow control									
Type of control		Direct									
Direction of flow		Non-reversible									
Pressure indicator	AG	Via pressure gauge for displaying output pressure									
	AD1/AD3	Via pressure sensor for displaying output pressure via LCD display and electrical output					-				
	AD7/AD9	Via pressure sensor for displaying output pressure via operational status indicator and electrical output					-				
Length [mm]	With cover plate	54		76			109		148		
	With MS pressure gauge AG	65		85			109		148		
	With adapter plate A8/A4	59		79			110		148		
	With pressure sensor AD1/AD3	83		103			-		-		
	With pressure sensor AD7/AD9	59		79			-		-		
Width [mm]		40		62			104		90		124
Height [mm]	Without silencer	104		151			272				255
	With silencer	151		257			431				421

1) Module without connecting thread/without connecting plate. The connecting plate must be ordered separately as an accessory → 889.

Standard nominal flow rate q_{nN}

Size		MS4		MS6			MS9		MS12	
Pneumatic connection 1, 2		G $\frac{1}{8}$	G $\frac{1}{4}$	G $\frac{1}{4}$	G $\frac{3}{8}$	G $\frac{1}{2}$	G $\frac{3}{4}$	G1	- ²⁾	- ²⁾
$q_{nN1 \rightarrow 2}$ [l/min]	In main flow direction ³⁾	1,200	2,200	3,000	5,500	8,700	14,500	18,000	8,000 ... 18,000	25,000 ... 32,000
$q_{nN2 \rightarrow 3}$ [l/min]	In relief direction ³⁾	1,900	1,700	6,800	6,600	6,200	14,900	14,100	13,200 ... 16,500	13,000

2) Dependent on the connecting plate selected, must be ordered separately as an accessory → 889.

3) Measured at $p_1 = 6$ bar and $p_2 = 5$ bar, $\Delta p = 1$ bar.

Operating conditions

Size		MS4	MS6	MS9	MS12
Operating medium		Compressed air to ISO 8573-1:2010 [7:4:4]			Compressed air to ISO 8573-1:2010 [:-:-]
		Inert gases			-
Note on operating/pilot medium		Lubricated operation possible (in which case lubricated operation will always be required)			-
Operating pressure [bar]		0 ... 14 (0 ... 10) ⁴⁾		0 ... 20	0 ... 20
Ambient temperature [°C]		-10 ... +60 (0 ... +50) ⁴⁾		-10 ... +60	-10 ... +60

4) Value in brackets applies to MS4/MS6-EM1 with pressure sensor AD...

Technical data

Materials	
Housing	Die-cast aluminium
Seals	NBR

Order code – MS4/MS6

Series		MS	EM1				
MS	Standard service unit						
Size							
4	Grid dimension 40 mm						
6	Grid dimension 62 mm						
Type							
EM1	On-off valve, manually operated						
Pneumatic connection							
MS4							
1/8	Female thread G1/8						
1/4	Female thread G1/4						
MS6							
1/4	Female thread G1/4						
3/8	Female thread G3/8						
1/2	Female thread G1/2						
Silencer							
–	Without silencer						
S	Silencer						
Pressure gauge/pressure gauge alternatives							
–	Cover plate						
AG	MS pressure gauge, bar						
A8	Adapter plate for EN pressure gauge 1/8 (MS4 only)						
A4	Adapter plate for EN pressure gauge 1/4						
AD1	Pressure sensor with LCD display, plug M8, 1 switching output PNP, 3-pin 1						
AD3	Pressure sensor with LCD display, plug M12, 1 switching output PNP, 4-pin, analogue output 4 ... 20 mA 1						
AD7	Pressure sensor with operational status indicator, plug M8, threshold value comparator, PNP, N/O contact 1						
AD9	Pressure sensor with operational status indicator, plug M8, window comparator, PNP, N/O contact 1						
Flow direction							
–	From left to right						
Z	From right to left						

1 Measuring range max. 10 bar.

On-off valves MS-EM, MS series

Order code – MS9

		MS	9	–	EM	–		–		–		–		–	
Series															
MS	Standard service unit														
Size															
9	Grid dimension 90 mm														
Type															
EM	On-off valve, manually operated														
Pneumatic connection															
3/4	Female thread G3/4														
1	Female thread G1														
G	Module without connecting thread, without connecting plate Connecting plates → 889														
Silencer															
–	Without silencer 1														
S	Silencer														
Pressure gauge/pressure gauge alternatives															
VS	Cover plate														
AG	MS pressure gauge														
A4	Adapter plate for EN pressure gauge 1/4														
Alternative pressure gauge scale															
–	No pressure gauge scale 2														
BAR	Bar 3														
Valve function															
–	3/2-way valve														
2	2/2-way valve 4														
Flow direction															
–	From left to right														
Z	From right to left														

1 Only with 2/2-way valve function.

3 Only with MS pressure gauge AG.

4 Not with silencer S.

2 Not with MS pressure gauge AG.

Order code – MS12

	MS	12	–	EM	–	G	–	–	–
Series									
MS	Standard service unit								
Size									
12	Grid dimension 124 mm								
Type									
EM	On-off valve, manually operated								
Pneumatic connection									
G	Module without connecting thread, without connecting plate Connecting plates → 889								
Silencer									
–	Without silencer								
S	Silencer								
Pressure gauge/pressure gauge alternatives									
–	Cover plate								
AG	MS pressure gauge, bar								
A4	Adapter plate for EN pressure gauge ¼								
Flow direction									
–	From left to right								
Z	From right to left								

Ordering – Product options

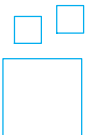

Configurable product

This product and all its options can be ordered using the configurator.

The configurator can be found under Products on the DVD or
→ www.festo.com/catalogue/...

Enter the type code in the search field.

★ Quick ordering

Part No.	Type
MS4	
541258	MS4-EM1-¼
541259	MS4-EM1-¼-S

Part No.	Type
MS6	
541267	MS6-EM1-½
541268	MS6-EM1-½-S

Part No.	Type
MS9	
562952	MS9-EM-G-S-VS

On-off valves MS-EM, MS series

Accessories – MS4/MS6

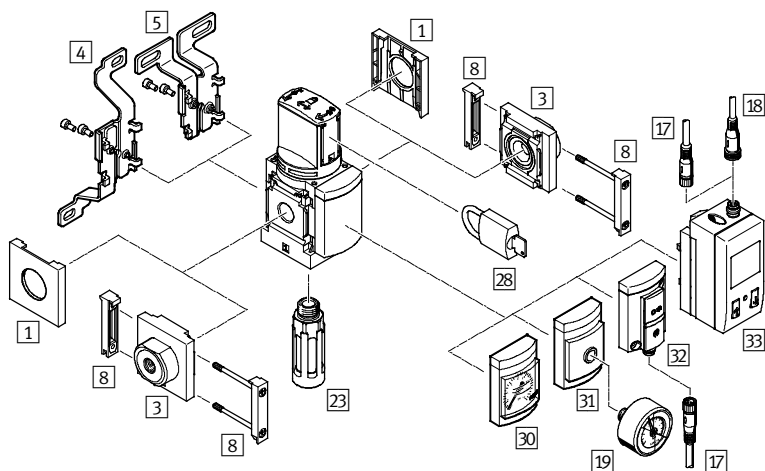

Accessories	→ Page/online
1 Cover cap MS4/6-END	889
3 Connecting plate MS4/6-AG...	889
4 Mounting bracket MS4/6-WB ¹⁾	889
5 Mounting bracket MS4-WBM ¹⁾	889
8 Module connector MS4/6-MV	889
17 Connecting cable NEBU-M8...-LE3	890
18 Connecting cable NEBU-M12...-LE4	890
19 Pressure gauge MA	891
23 Silencer U	891
28 Padlock LRVS-D	891
30 MS pressure gauge AG	857
31 Adapter plate A8/A4 for EN pressure gauge 1/8/1/4	857

1) Mounting component for individual device.

Accessories	→ Page/online
32 Pressure sensor with operational status indicator AD7/AD9	857
33 Pressure sensor with LCD display AD1/AD3	857
- Mounting plate MS4/6-AEND	889
- Mounting bracket MS4/6-WP ²⁾	889
- Mounting bracket MS4/6-WPB ²⁾	889
- Mounting bracket MS4/6-WPE ²⁾	889
- Mounting bracket MS4/6-WPM ²⁾	889
- Module connector MS4/6-RMV	892
- Module connector MS4-6-AMV	892
- Module connector MS6-9-ARMV	892
- Power supply module MS4/6-E-IPM	ms*-e-ipm*
- Branching module MS4/6-A-IPM	ms*-a*ipm*

2) Mounting and connecting component for combination or for individual device with connecting plate MS4/6-AG... [3]/with mounting plate MS4/6-AEND.

Accessories – MS9

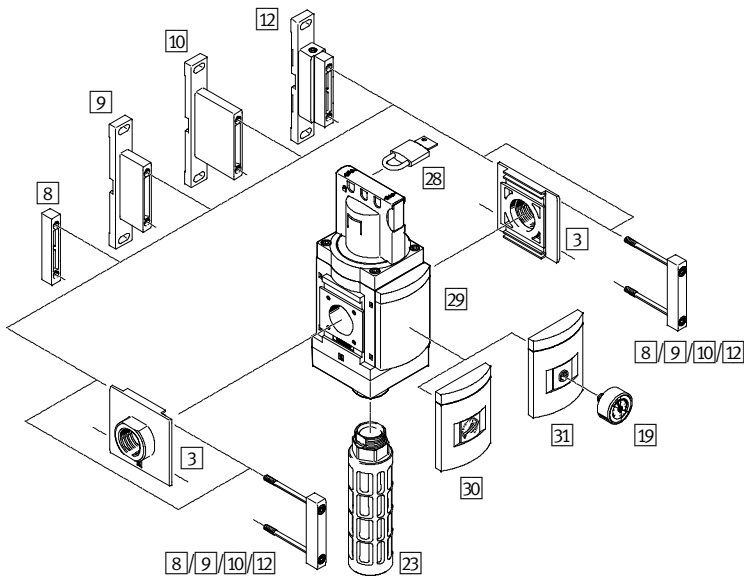

Accessories	→ Page/online
3 Connecting plate MS9-AG... ¹⁾	889
8 Module connector MS9-MV ¹⁾	889
9 Mounting bracket MS9-WP	889
10 Mounting bracket MS9-WPB	889
12 Mounting bracket MS9-WPM ¹⁾	889
19 Pressure gauge MA	891
23 Silencer U	891

Accessories	→ Page/online
28 Padlock LRVS-D	891
29 Cover plate VS	858
30 MS pressure gauge AG	858
31 Adapter plate A4 for EN pressure gauge 1/4	858
- Module connector MS9-RMV	892
- Module connector MS6-9-ARMV	892
- Module connector MS9-12-ARMV	892

1) Not suitable for individual devices with connecting thread G3/4 or G1.

Accessories – MS12

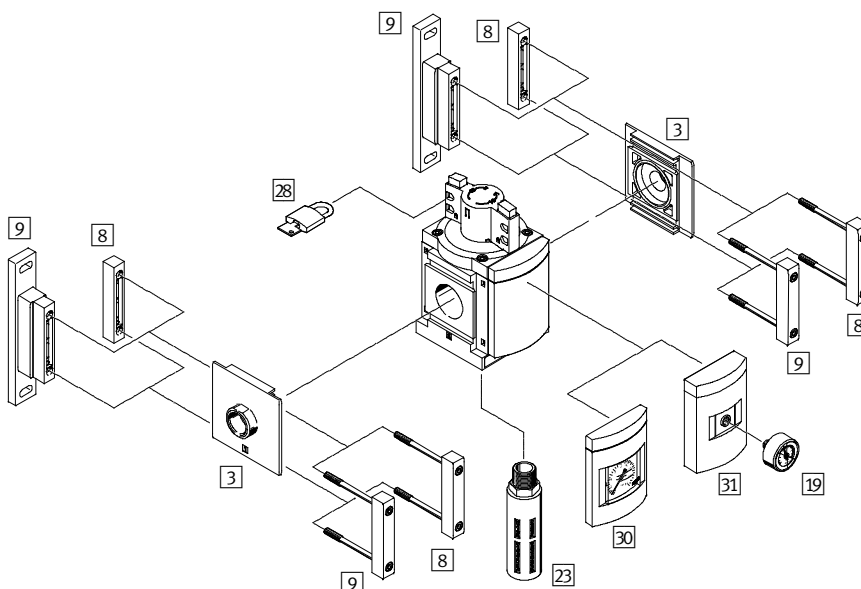

Accessories	→ Page/online
3 Connecting plate MS12-AG...	889
8 Module connector MS12-MV	889
9 Mounting bracket MS12-WP	889
19 Pressure gauge MA	891
23 Silencer U	891

Accessories	→ Page/online
28 Padlock LRVS-D	891
30 MS pressure gauge AG	859
31 Adapter plate A4 for EN pressure gauge 1/4	859
- Module connector MS9-12-ARMV	892

On-off valves MS-EE, MS series



- Electrically actuated on-off valve for pressurising and exhausting pneumatic systems
- Choice of three voltage ranges
- 4 sizes:
MS4 – grid dimension 40 mm, MS6 – grid dimension 62 mm, MS9 – grid dimension 90 mm, MS12 – grid dimension 124 mm
- Selected types in accordance with the ATEX Directive for explosive atmospheres → www.festo.com/catalogue/ex
- ★ Quick ordering of basic designs → 867

→ www.festo.com/catalogue/ms*-ee

Product range overview

Size	Pneumatic connection	Product options											
		V24	10V24	S	VS	AG	A8	A4	AD...	BAR	2	Z	
4	1/8, 1/4	■	■	■	-1)	■	■	■	■	■	-	-	■
6	1/4, 3/8, 1/2	■	■	■	-1)	■	-	■	■	■	-	-	■
9	3/4, 1, G	■	-	■	■	■	-	■	-	■	■	■	■
12	G	■	-	■	-1)	■	-	■	-	-	-	-	■

1) Cover plate included in the basic configuration by default.

Product options

1/8	Female thread G1/8	10V24	AD1	Pressure sensor with LCD display, plug M8, 1 switching output PNP, 3-pin	AD10	Pressure sensor with operational status indicator, plug M8, window comparator, PNP, N/C contact
1/4	Female thread G1/4	Supply voltage 24 V DC (pin allocation to EN 175301), 4 ... 10 bar	AD2	Pressure sensor with LCD display, plug M8, 1 switching output NPN, 3-pin	BAR	Pressure gauge scale in bar
3/8	Female thread G3/8	10V24P	AD3	Pressure sensor with LCD display, plug M12, 1 switching output PNP, 4-pin, analogue output 4 ... 20 mA	PSI	Pressure gauge scale in psi
1/2	Female thread G1/2	Supply voltage 24 V DC, M12 to IEC 61076-2-101, 4 ... 10 bar	AD4	Pressure sensor with LCD display, plug M12, 1 switching output NPN, 4-pin, analogue output 4 ... 20 mA	MPA	Pressure gauge scale in Mpa
3/4	Female thread G3/4	V110	AD7	Pressure sensor with operational status indicator, plug M8, threshold value comparator, PNP, N/O contact	2	2/2-way valve
1	Female thread G1	Supply voltage 110 V AC (pin allocation to EN 175301), 3 ... 18 bar	AD8	Pressure sensor with operational status indicator, plug M8, threshold value comparator, PNP, N/C contact	WP	Mounting bracket
AGA	Connecting plate G1/8	V230	AD9	Pressure sensor with operational status indicator, plug M8, window comparator, PNP, N/O contact	WPM	Mounting bracket
AGB	Connecting plate G1/4	Supply voltage 230 V AC (pin allocation to EN 175301), 3 ... 18 bar			WPB	Mounting bracket for large wall gap
AGC	Connecting plate G3/8	S			WB	Mounting bracket
AGD	Connecting plate G1/2	VS			WBM	Mounting bracket
AGE	Connecting plate G3/4	AG			EX2	EU certification (II 3GD in accordance with EU Directive 94/9/EC)
AGF	Connecting plate G1	A8			UL1	UL certification (cULus, ordinary locations for Canada and USA)
AGG	Connecting plate G1 1/4	A4			Z	Flow direction from right to left
AGH	Connecting plate G1 1/2	RG				
AGI	Connecting plate G2	Integrated pressure gauge, red/green scale				
G	Module without connecting thread, without connecting plate					
V24	Supply voltage 24 V DC (pin allocation to EN 175301), 3 ... 18 bar					
V24P	Supply voltage 24 V DC (pin allocation plug M12 to DESINA), 3 ... 16 bar					

Technical data

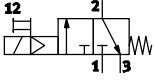
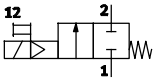
Download CAD data → www.festo.com

Technical data		Download CAD data → www.festo.com									
Size		MS4		MS6			MS9		MS12		
Pneumatic connection 1, 2		G1/8	G1/4	G1/4	G3/8	G1/2	G3/4	G1	– ¹⁾	– ¹⁾	
Pneumatic connection 3		G1/4		G1/2			G1		G1		
Design		Piston spool valve									
Type of mounting		Via accessories In-line installation									
Mounting position		Any									
Actuation type		Electric									
Valve function		–					2/2-way valve, closed, single solenoid		–		
		3/2-way valve, closed, single solenoid									
Exhaust function		No flow control									
Manual override		Non-detenting/detenting (supply voltage V24)									
		Non-detenting (supply voltage 10V24)						–			
Reset method		Mechanical spring									
Switching position display		Via accessories									
Type of control		Piloted									
Pilot air supply		Internal									
Direction of flow		Non-reversible									
Pressure indicator	AG	Via pressure gauge for displaying output pressure									
	AD1/AD3	Via pressure sensor for displaying output pressure via LCD display and electrical output					–				
	AD7/AD9	Via pressure sensor for displaying output pressure via operational status indicator and electrical output					–				
Length [mm]	With cover plate	75 (63) ²⁾		97 (83) ²⁾			109		148		
	With MS pressure gauge AG	86 (65) ²⁾		106 (85) ²⁾			109		148		
	With adapter plate A8/A4	80 (63) ²⁾		100 (83) ²⁾			110		148		
	With pressure sensor AD1/AD3	104		124			–		–		
	With pressure sensor AD7/AD9	80		100			–		–		
Width [mm]		40		62			104		90		124
Height [mm]	Without silencer	143		186			239		237		
	With silencer	191		292			398		403		

1) Module without connecting thread/without connecting plate. The connecting plate must be ordered separately as an accessory → 889.

2) Value in brackets with repositioned solenoid head (180°), i.e. solenoid points to the front.

Standard nominal flow rate q_{nN}

Size		MS4		MS6			MS9		MS12	
Pneumatic connection 1, 2		G1/8	G1/4	G1/4	G3/8	G1/2	G3/4	G1	– ³⁾	– ³⁾
$q_{nN1 \rightarrow 2}$ [l/min]	In main flow direction ⁴⁾	1,000	2,000	2,600	5,500	7,000	14,500	18,000	8,000	25,000 ... 32,000
									...	18,000
$q_{nN2 \rightarrow 3}$ [l/min]	In relief direction ⁴⁾	1,600	1,600	7,000	6,200	5,500	14,900	14,100	13,200	8,900
									...	16,500

3) Dependent on the connecting plate selected, must be ordered separately as an accessory → 889.

4) Measured at $p_1 = 6$ bar and $p_2 = 5$ bar, $\Delta p = 1$ bar.

On-off valves MS-EE, MS series

Technical data

Electrical data						
Size	MS4		MS6		MS9	MS12
Supply voltage	V24	10V24	V24	10V24	V24	V24
Coil characteristics	24 V DC: 1.5 W	24 V DC: 2.5 W	24 V DC: 1.5 W	24 V DC: 2.5 W	24 V DC: 4.5 W	24 V DC: 4.5 W
Electrical connection	Plug, square design to EN 175301-803, type C				Plug, square design to EN 175301-803, type A	
Protection class for solenoid coil	IP65					
Duty cycle [%]	100					

Operating conditions						
Size	MS4		MS6		MS9	MS12
Supply voltage	V24	10V24	V24	10V24	V24	V24
Operating medium	Compressed air to ISO 8573-1:2010 [7:4:4]				Inert gases	
					–	Inert gases
Note on operating/pilot medium	Lubricated operation possible (in which case lubricated operation will always be required)					
Operating pressure [bar]	4 ... 14 (4 ... 10) ¹⁾	4 ... 10	4 ... 18 (4 ... 10) ¹⁾	4 ... 10	3.5 ... 16	3 ... 16
Ambient temperature [°C]	-10 ... +60 (0 ... +50) ¹⁾	-10 ... +50 (0 ... +50) ¹⁾	-10 ... +60 (0 ... +50) ¹⁾	-10 ... +50 (0 ... +50) ¹⁾	-10 ... +60	-10 ... +50

1) Value in brackets applies to MS4/MS6-EE with pressure sensor AD ...

Materials	
Housing	Die-cast aluminium
Seals	NBR

On-off valves MS-EE, MS series

Order code – MS9

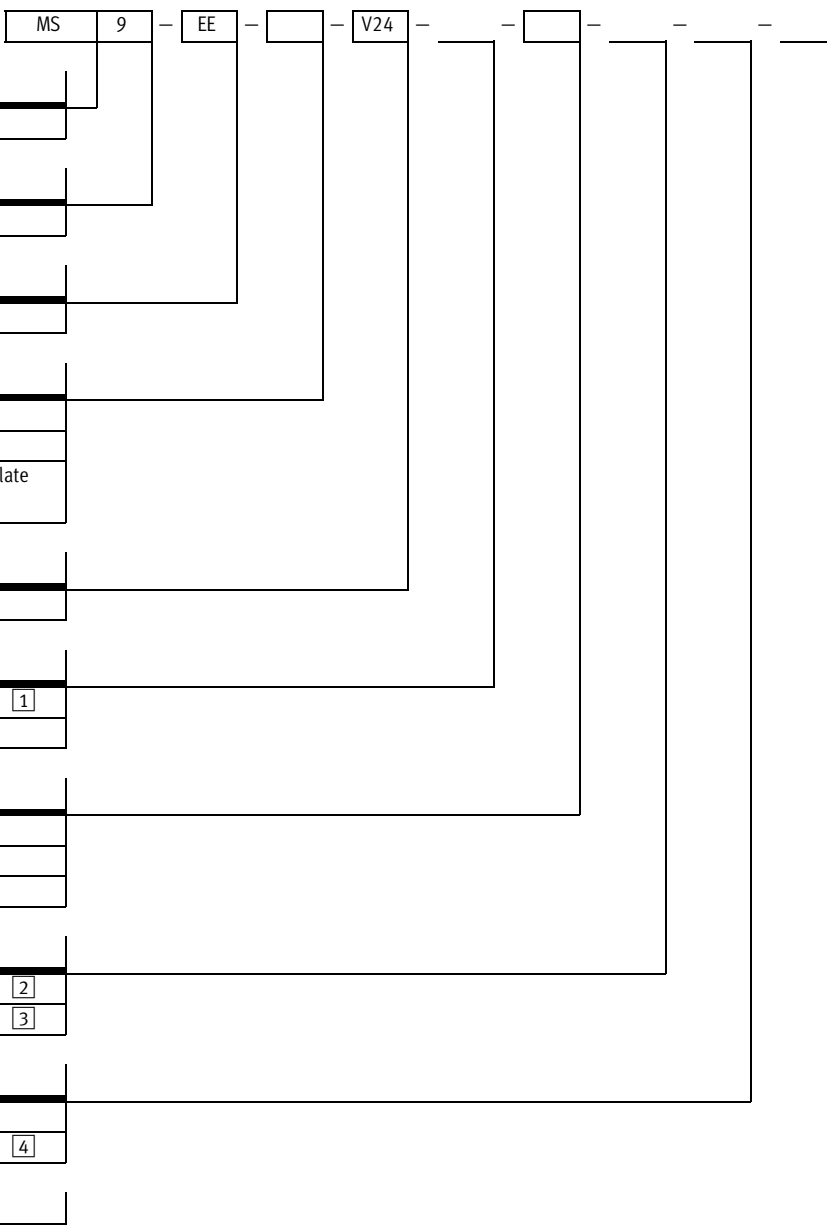

1 Only with 2/2-way valve function.

3 Only with MS pressure gauge AG.

4 Not with silencer S.

2 Not with MS pressure gauge AG.

Order code – MS12

	MS	12	–	EE	–	G	–	V24	–	–	–
Series											
MS	Standard service unit										
Size											
12	Grid dimension 124 mm										
Type											
EE	On-off valve, electrically actuated										
Pneumatic connection											
G	Module without connecting thread, without connecting plate Connecting plates → 889										
Supply voltage											
V24	24 V DC										
Silencer											
–	Without silencer										
S	Silencer										
Pressure gauge/pressure gauge alternatives											
–	Cover plate										
AG	MS pressure gauge, bar										
A4	Adapter plate for EN pressure gauge 1/4										
Flow direction											
–	From left to right										
Z	From right to left										

Ordering – Product options

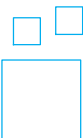

Configurable product

This product and all its options can be ordered using the configurator.

The configurator can be found under Products on the DVD or
→ www.festo.com/catalogue/...

Enter the type code in the search field.

★ Quick ordering

Part No.	Type
MS4	
542578	MS4-EE-1/4-10V24
542598	MS4-EE-1/4-10V24-S

Part No.	Type
MS6	
542582	MS6-EE-1/2-10V24
542602	MS6-EE-1/2-10V24-S

Part No.	Type
MS9	
562940	MS9-EE-G-V24-S-VS

On-off valves MS-EE, MS series

Accessories – MS4/MS6

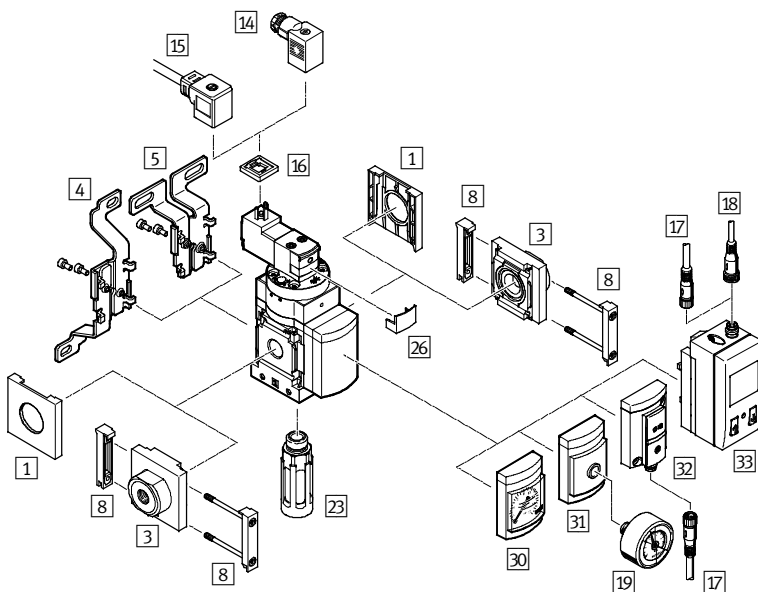

Accessories	→ Page/online
1 Cover cap MS4/6-END	889
3 Connecting plate MS4/6-AG...	889
4 Mounting bracket MS4/6-WB ¹⁾	889
5 Mounting bracket MS4/6-WBM ¹⁾	889
8 Module connector MS4/6-MV	889
14 Plug socket MSSD-EB	890
15 Plug socket with cable KMEB	890
16 Illuminating seal MEB-LD	890
17 Connecting cable NEBU-M8...-LE3	890
18 Connecting cable NEBU-M12...-LE4	890
19 Pressure gauge MA	891
23 Silencer U	891
26 Locking clip CPV18-HV	891
30 MS pressure gauge AG	865

1) Mounting component for individual device.

Accessories	→ Page/online
31 Adapter plate A8/A4 for EN pressure gauge 1/8/1/4	865
32 Pressure sensor with operational status indicator AD7/AD9	865
33 Pressure sensor with LCD display AD1/AD3	865
- Mounting plate MS4/6-AEND	889
- Mounting bracket MS4/6-WP ²⁾	889
- Mounting bracket MS4/6-WPB ²⁾	889
- Mounting bracket MS4/6-WPE ²⁾	889
- Mounting bracket MS4/6-WPM ²⁾	889
- Module connector MS4/6-RMV	892
- Module connector MS4/6-AMV	892
- Module connector MS6-9-ARMV	892
- Power supply module MS4/6-E-IPM	ms*-e-ipm*
- Branching module MS4/6-A-IPM	ms*-a-ipm*

2) Mounting and connecting component for combination or for individual device with connecting plate MS4/6-AG... [3]/with mounting plate MS4/6-AEND.

Accessories – MS9

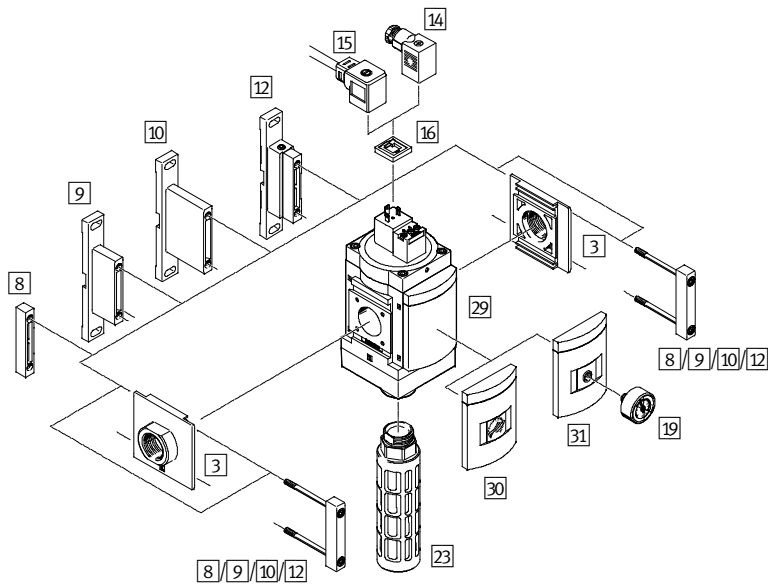

Accessories	→ Page/online
3 Connecting plate MS9-AG... ¹⁾	889
8 Module connector MS9-MV ¹⁾	889
9 Mounting bracket MS9-WP	889
10 Mounting bracket MS9-WPB	889
12 Mounting bracket MS9-WPM ¹⁾	889
14 Plug socket MSSD-C	890
15 Plug socket with cable KMC	890
16 Illuminating seal MC-LD	890

Accessories	→ Page/online
19 Pressure gauge MA	891
23 Silencer U	891
29 Cover plate VS	866
30 MS pressure gauge AG	866
31 Adapter plate A4 for EN pressure gauge 1/4	866
- Module connector MS9-RMV	892
- Module connector MS6-9-ARMV	892
- Module connector MS9-12-ARMV	892

1) Not suitable for individual devices with connecting thread G3/4 or G1.

Accessories – MS12

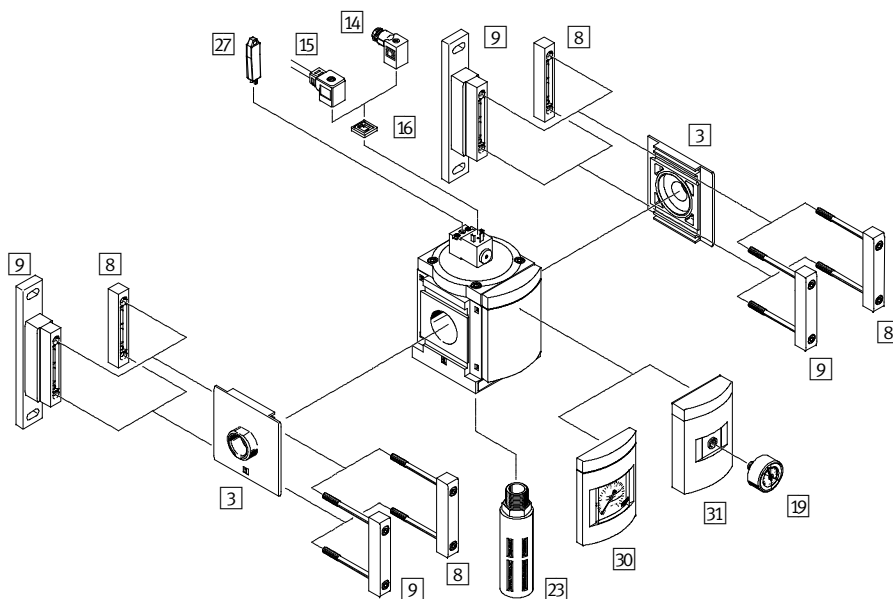

Accessories	→ Page/online
3 Connecting plate MS12-AG...	889
8 Module connector MS12-MV	889
9 Mounting bracket MS12-WP	889
14 Plug socket MSSD-C	890
15 Plug socket with cable KMC	890
16 Illuminating seal MC-LD	890

Accessories	→ Page/online
19 Pressure gauge MA	891
23 Silencer U	891
27 Manual override AHB-MD/MF/MV	891
30 MS pressure gauge AG	867
31 Adapter plate A4 for EN pressure gauge 1/4	867
- Module connector MS9-12-ARMV	892

Soft-start valves MS-DL, MS series



- Pneumatically actuated soft-start valve for slowly pressurising and exhausting pneumatic systems
- Adjustable switching time delay
- 3 sizes:
MS4 – grid dimension 40 mm, MS6 – grid dimension 62 mm, MS12 – grid dimension 124 mm
- ★ Quick ordering of basic designs → 873

→ www.festo.com/catalogue/ms*-dl

Product range overview

Size	Pneumatic connection	Product options				
		AG	A8	A4	AD...	Z
4	1/8, 1/4	■	■	■	■	■
6	1/4, 3/8, 1/2	■	–	■	■	■
12	G	■	–	■	–	■

Product options

1/8	Female thread G1/8	A8	Adapter plate for EN pressure gauge 1/8, without pressure gauge	AD4	Pressure sensor with LCD display, plug M12, 1 switching output NPN, 4-pin, analogue output 4 ... 20 mA	PSI	Pressure gauge scale in psi
1/4	Female thread G1/4	A4	Adapter plate for EN pressure gauge 1/4, without pressure gauge	AD7	Pressure sensor with operational status indicator, plug M8, threshold value comparator, PNP, N/O contact	MPA	Pressure gauge scale in Mpa
3/8	Female thread G3/8	RG	Integrated pressure gauge, red/green scale	AD8	Pressure sensor with operational status indicator, plug M8, threshold value comparator, PNP, N/C contact	WP	Mounting bracket
1/2	Female thread G1/2	AD1	Pressure sensor with LCD display, plug M8, 1 switching output PNP, 3-pin	AD9	Pressure sensor with operational status indicator, plug M8, window comparator, PNP, N/O contact	WPM	Mounting bracket
AGA	Connecting plate G1/8	AD2	Pressure sensor with LCD display, plug M8, 1 switching output NPN, 3-pin	AD10	Pressure sensor with operational status indicator, plug M8, window comparator, PNP, N/C contact	WB	Mounting bracket
AGB	Connecting plate G1/4	AD3	Pressure sensor with LCD display, plug M12, 1 switching output PNP, 4-pin, analogue output 4 ... 20 mA			WBM	Mounting bracket
AGC	Connecting plate G3/8					UL1	UL certification (cULus, ordinary locations for Canada and USA)
AGD	Connecting plate G1/2					Z	Flow direction from right to left
AGE	Connecting plate G3/4						
AGF	Connecting plate G1						
AGG	Connecting plate G1 1/4						
AGH	Connecting plate G1 1/2						
AGI	Connecting plate G2						
G	Module without connecting thread, without connecting plate						
AG	MS pressure gauge						

Technical data

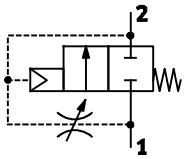

Technical data		Download CAD data → www.festo.com					
Size		MS4		MS6		MS12	
Pneumatic connection 1, 2		G $\frac{1}{8}$	G $\frac{1}{4}$	G $\frac{1}{4}$	G $\frac{3}{8}$	G $\frac{1}{2}$	– ¹⁾
Design		Piston seat					
Type of mounting		Via accessories					
		In-line installation					
Mounting position		Any					
Actuation type		Pneumatic					
Valve function		2/2-way valve					
Exhaust function		With flow control					
Reset method		Mechanical spring					
Type of control		Direct					
Pilot air supply		External				Internal	
Direction of flow		Non-reversible					
Pressure indicator	AG	Via pressure gauge for displaying output pressure					
	AD1/AD3	Via pressure sensor for displaying output pressure via LCD display and electrical output				–	
	AD7/AD9	Via pressure sensor for displaying output pressure via operational status indicator and electrical output				–	
Length [mm]	With cover plate	54		76		148	
	With MS pressure gauge AG	65		85		148	
	With adapter plate A8/A4	59		79		148	
	With pressure sensor AD1/AD3	83		103		–	
	With pressure sensor AD7/AD9	59		79		–	
Width [mm]		40		62		124	
Height [mm]		83		108		178	

1) Module without connecting thread/without connecting plate. The connecting plate must be ordered separately as an accessory → 889.

Standard nominal flow rate q_{nN}		MS4		MS6		MS12	
Size		G $\frac{1}{8}$	G $\frac{1}{4}$	G $\frac{1}{4}$	G $\frac{3}{8}$	G $\frac{1}{2}$	
$q_{nN1 \rightarrow 2}$ [l/min]	In main flow direction ²⁾	1,000	2,000	2,800	5,050	6,450	25,000 ... 42,000
$q_{nN2 \rightarrow 1}$ [l/min]	In relief direction ²⁾	1,000	2,000	2,800	5,050	6,400	25,000 ... 42,000

2) Measured at $p_1 = 6$ bar and $p_2 = 5$ bar, $\Delta p = 1$ bar.

Operating conditions		MS4		MS6		MS12
Size						
Operating medium		Compressed air to ISO 8573-1:2010 [7:4:4]				Compressed air to ISO 8573-1:2010 [7:--:--]
		Inert gases				–
Note on operating/pilot medium		Lubricated operation possible (in which case lubricated operation will always be required)				
Operating pressure [bar]		4 ... 14 (4 ... 10) ³⁾		4 ... 18 (4 ... 10) ³⁾		2 ... 20
Ambient temperature [°C]		–10 ... +60 (0 ... +50) ³⁾		–10 ... +60 (0 ... +50) ³⁾		–10 ... +60

3) Value in brackets applies to MS4/MS6-DL with pressure sensor AD...

Materials	
Housing	Die-cast aluminium
Seals	NBR

Soft-start valves MS-DL, MS series

Order code – MS4/MS6

		MS	-	DL	-	-	-
Series							
MS	Standard service unit						
Size							
4	Grid dimension 40 mm						
6	Grid dimension 62 mm						
Type							
DL	Pneumatically actuated soft-start valve						
Pneumatic connection							
MS4							
1/8	Female thread G1/8						
1/4	Female thread G1/4						
MS6							
1/4	Female thread G1/4						
3/8	Female thread G3/8						
1/2	Female thread G1/2						
Pressure gauge/pressure gauge alternatives							
-	Cover plate						
AG	MS pressure gauge, bar						
A8	Adapter plate for EN pressure gauge 1/8 (MS4 only)						
A4	Adapter plate for EN pressure gauge 1/4						
AD1	Pressure sensor with LCD display, plug M8, 1 switching output PNP, 3-pin 1						
AD3	Pressure sensor with LCD display, plug M12, 1 switching output PNP, 4-pin, analogue output 4 ... 20 mA 1						
AD7	Pressure sensor with operational status indicator, plug M8, threshold value comparator, PNP, N/O contact 1						
AD9	Pressure sensor with operational status indicator, plug M8, window comparator, PNP, N/O contact 1						
Flow direction							
-	From left to right						
Z	From right to left						

1 Measuring range max. 10 bar.

12

Order code – MS12

	MS	12	–	DL	–	G	–	–
Series	MS		Standard service unit					
Size	12		Grid dimension 124 mm					
Type	DL		Pneumatically actuated soft-start valve					
Pneumatic connection	G		Module without connecting thread, without connecting plate Connecting plates → 889					
Pressure gauge/pressure gauge alternatives	–		Cover plate					
	AG		MS pressure gauge, bar					
	A4		Adapter plate for EN pressure gauge 1/4					
Flow direction	–		From left to right					
	Z		From right to left					

Ordering – Product options

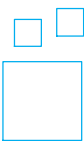

Configurable product

This product and all its options can be ordered using the configurator.

The configurator can be found under Products on the DVD or
→ www.festo.com/catalogue/...

Enter the type code in the search field.

★ Quick ordering

Part No.	Type
MS4	
529531	MS4-DL-1/4

Part No.	Type
MS6	
529817	MS6-DL-1/2

Soft-start valves MS-DL, MS series

Accessories – MS4/MS6

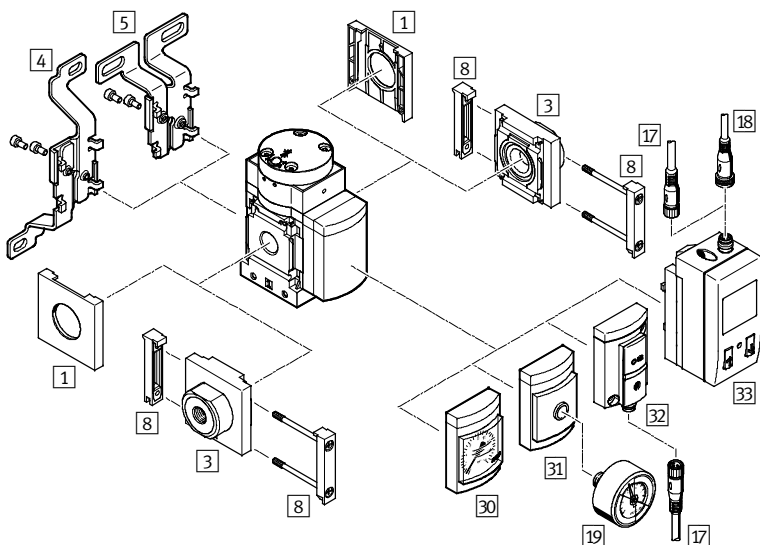

Accessories	→ Page/online
1 Cover cap MS4/6-END	889
3 Connecting plate MS4/6-AG...	889
4 Mounting bracket MS4/6-WB ¹⁾	889
5 Mounting bracket MS4/6-WBM ¹⁾	889
8 Module connector MS4/6-MV	889
17 Connecting cable NEBU-M8...-LE3	890
18 Connecting cable NEBU-M12...-LE4	890
19 Pressure gauge MA	891
30 MS pressure gauge AG	872
31 Adapter plate A8/A4 for EN pressure gauge 1/8/1/4	872
32 Pressure sensor with operational status indicator AD7/AD9	872

1) Mounting component for individual device.

Accessories	→ Page/online
33 Pressure sensor with LCD display AD1/AD3	872
- Mounting plate MS4/6-AEND	889
- Mounting bracket MS4/6-WP ²⁾	889
- Mounting bracket MS4/6-WPB ²⁾	889
- Mounting bracket MS4/6-WPE ²⁾	889
- Mounting bracket MS4/6-WPM ²⁾	889
- Module connector MS4/6-RMV	892
- Module connector MS4/6-AMV	892
- Module connector MS6-9-ARMV	892
- Power supply module MS4/6-E-IPM	ms*-e-ipm*
- Branching module MS4/6-A-IPM	ms*-a*ipm*

2) Mounting and connecting component for combination or for individual device with connecting plate MS4/6-AG... [3] with mounting plate MS4/6-AEND.

Accessories – MS12

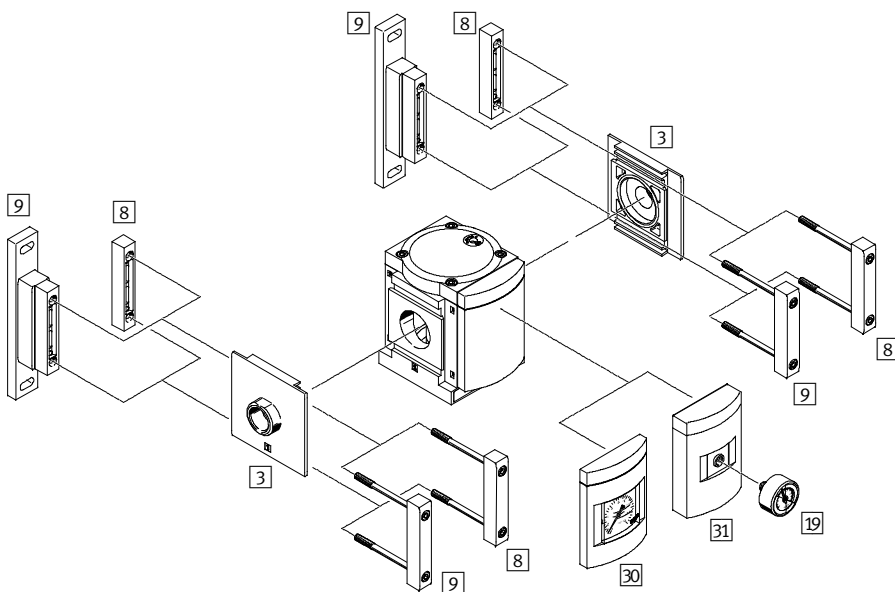

Accessories	→ Page/online
3 Connecting plate MS12-AG...	889
8 Module connector MS12-MV	889
9 Mounting bracket MS12-WP	889
19 Pressure gauge MA	891

Accessories	→ Page/online
30 MS pressure gauge AG	873
31 Adapter plate A4 for EN pressure gauge 1/4	873
- Module connector MS9-12-ARMV	ms*-armv

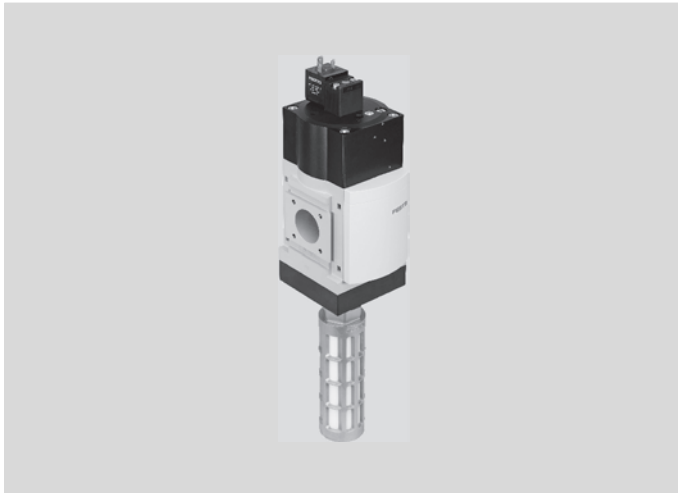

- Performance Level c, category 1 to EN ISO 13849-1
 - For reducing pressure quickly and reliably and for building up pressure gradually
 - The filling flow rate can be set via a flow control valve for gradual pressure build-up
 - Adjustable pressure switchover point
 - 2 sizes:
MS6 – grid dimension 62 mm, MS9 – grid dimension 90 mm
- ★ Quick ordering of basic designs → 879

→ www.festo.com/catalogue/ms*-sv

Product range overview

Size	Pneumatic connection	Product options											
		C	V24	10V24	S	VS	AG	A4	AD...	BAR	MH	MK	Z
6	1/2	■	■	■	■	– ¹⁾	■	■	■	–	–	■	■
9	3/4, 1, G	■	■	–	■	■	■	■	■	■	■	■	■

1) Cover plate included in the basic configuration by default.

Product options

1/2	Female thread G1/2	10V24P		AD3	Pressure sensor with LCD display, plug M12, 1 switching output PNP, 4-pin, analogue output 4 ... 20 mA	MPA	Pressure gauge scale in Mpa
3/4	Female thread G3/4	Supply voltage 24 V DC, M12 to IEC 61076-2-101, 3 ... 10 bar		AD4	Pressure sensor with LCD display, plug M12, 1 switching output NPN, 4-pin, analogue output 4 ... 20 mA	WP	Mounting bracket
1	Female thread G1	V110	Supply voltage 110 V AC (pin allocation to EN 175301), 3 ... 18 bar	AD7	Pressure sensor with operational status indicator, plug M8, threshold value comparator, PNP, N/O contact	WPM	Mounting bracket
AGB	Connecting plate G1/4	V230	Supply voltage 230 V AC (pin allocation to EN 175301), 3 ... 18 bar	AD8	Pressure sensor with operational status indicator, plug M8, threshold value comparator, PNP, N/C contact	WPB	Mounting bracket for large wall gap
AGC	Connecting plate G3/8	S	Silencer	AD9	Pressure sensor with operational status indicator, plug M8, window comparator, PNP, N/O contact	WB	Mounting bracket
AGD	Connecting plate G1/2	VS	Cover plate	AD10	Pressure sensor with operational status indicator, plug M8, window comparator, PNP, N/C contact	MH	Tamper protection, cover for manual override only
AGE	Connecting plate G3/4	AG	MS pressure gauge	BAR	Pressure gauge scale in bar	MK	Tamper protection, full cover for manual override and adjusting screws
AGF	Connecting plate G1	A4	Adapter plate for EN pressure gauge 1/4, without pressure gauge	PSI	Pressure gauge scale in psi	UL1	UL certification (cULus, ordinary locations for Canada and USA)
AGG	Connecting plate G1 1/4	RG	Integrated pressure gauge, red/green scale	Z	Flow direction from right to left		
AGH	Connecting plate G1 1/2	AD1	Pressure sensor with LCD display, plug M8, 1 switching output PNP, 3-pin				
G	Module without connecting thread, without connecting plate	AD2	Pressure sensor with LCD display, plug M8, 1 switching output NPN, 3-pin				
C	Performance Level "c"						
V24	Supply voltage 24 V DC (pin allocation to EN 175301), 3 ... 18 bar						
V24P	Supply voltage 24 V DC with M12 plug socket adapter (pin allocation to EN 60947-5-2), 3 ... 18 bar						
10V24	Supply voltage 24 V DC (pin allocation to EN 175301), 3 ... 10 bar						

Soft-start/quick exhaust valves MS-SV-C, MS series

FESTO

Technical data

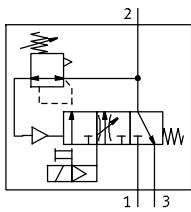

Electro-pneumatic soft-start/quick exhaust valve for gradual pressurisation and quick exhausting of system

components (single channel). The main flow control valve in the end cap permits a gradual build-up of output

pressure p2. Once the output pressure p2 has reached the set pressure switchover point (switching pressure), the

valve opens and the full operating pressure p1 is present at the output.

Safety characteristics		MS6	MS9
Size			
Conforms to standard		EN ISO 13849-1	
Safety function		Exhausting	
Performance Level (PL)		Exhausting: up to category 1, PL c	
Shock resistance		Shock test with severity level 2 according to FN 942017-5 and EN 60068-2-27	Shock test with severity level 1 according to FN 942017-5 and EN 60068-2-27
Vibration resistance		Transport application test with severity level 2 according to FN 942017-4 and EN 60068-2-6	Transport application test with severity level 1 according to FN 942017-4 and EN 60068-2-6

Technical data		MS6	MS9	Download CAD data → www.festo.com	
Size					
Pneumatic connection 1, 2		G1/2	G3/4	G1	1)
Pneumatic connection 3		G3/4	G1		
Design		Piston spool valve			
Type of mounting		Via accessories In-line installation			
Mounting position		Any			
Valve function		3/2-way valve, closed, single solenoid Soft-start function, adjustable			
Exhaust function		No flow control			
Manual override	At the pilot solenoid valve	Non-detenting/detenting (supply voltage V24) Non-detenting (supply voltage 10V24)			
	At the soft-start/quick exhaust valve	Detenting, self-resetting			
Reset method		Mechanical spring			
Type of control		Piloted			
Pressure indicator	AG	Via pressure gauge for displaying output pressure			
	AD1/AD3	Via pressure sensor for displaying output pressure via LCD display and electrical output		-	
	AD7/AD9	Via pressure sensor for displaying output pressure via operational status indicator and electrical output			
Length [mm]	With cover plate VS	76	109		
	With MS pressure gauge AG	77	109		
	With adapter plate A4	78.5	110		
	With pressure sensor AD1/AD3	102	-		
	With pressure sensor AD7/AD9	79	112		
Width [mm]		62	104	90	
Height [mm]	Without silencer	181	248		
	With silencer	311	437		

1) Module without connecting thread/without connecting plate. The connecting plate must be ordered separately as an accessory → 889.

Technical data

Flow rate characteristics				
Size	MS6		MS9	
Pneumatic connection 1, 2	G1/2		G3/4	G1 ⁻¹⁾
Standard nominal flow rate $q_{nN}^{2)}$ in main flow direction 1→2 [l/min]	5,700		14,150	16,460
Standard flow rate exhaust 6→0 bar with silencer S [l/min]	7,600		21,450	20,870
				8,300 ... 16,550
				19,730 ... 21,720

- 1) Dependent on the connecting plate selected, must be ordered separately as an accessory → 889.
- 2) Measured at $p_1 = 6$ bar and $p_2 = 5$ bar, $\Delta p = 1$ bar.

Electrical data			
Size	MS6		MS9
Supply voltage	V24	10V24	V24
Coil characteristics	24 V DC: 1.5 W	24 V DC: 2.5 W	24 V DC: 8.4 W
Electrical connection	Plug, 2-pin, to EN 175301-803, type C		Plug, square design to EN 175301-803, type A
Protection class	IP65 with plug socket		
Duty cycle [%]	100		

Operating conditions			
Size	MS6		MS9
Supply voltage	V24	10V24	V24
Operating medium	Compressed air to ISO 8573-1:2010 [7:4:4]		
Note on operating/pilot medium	Lubricated operation possible (in which case lubricated operation will always be required)		
Operating pressure [bar]	3 ... 18 (3 ... 10) ³⁾	3 ... 10	3.5 ... 16 (3.5 ... 10) ³⁾
Ambient temperature [°C]	0 ... +60 (0 ... +50) ³⁾		
Noise level [db (A)]	-		93

- 3) Value in brackets applies to MS6/MS9-SV-C with pressure sensor AD...

Materials		
Size	MS6	MS9
Housing	Die-cast aluminium	
Piston spool	High-alloy stainless steel	Brass
Seals	NBR	

Soft-start/quick exhaust valves MS-SV-C, MS series

FESTO

Order code – MS6

		MS	6	–	SV	–	1/2	–	C	–	–	–	–	–	–	–	–	–	–	
Series																				
MS	Standard service unit																			
Size																				
6	Grid dimension 62 mm																			
Type																				
SV	Soft-start/quick exhaust valve																			
Pneumatic connection																				
1/2	Female thread G1/2																			
Performance Level																				
C	Category 1, 1-channel, to EN ISO 13849-1																			
Supply voltage																				
V24	24 V DC (pin allocation to EN 175301), 3 ... 18 bar																			
10V24	24 V DC (pin allocation to EN 175301), 3 ... 10 bar																			
Silencer																				
–	None																			
S	Silencer																			
Pressure gauge/pressure gauge alternatives																				
–	Cover plate																			
AG	MS pressure gauge, bar																			
A4	Adapter plate for EN pressure gauge 1/4																			
AD1	Pressure sensor with LCD display, plug M8, 1 switching output PNP, 3-pin 1																			
AD3	Pressure sensor with LCD display, plug M12, 1 switching output PNP, 4-pin, analogue output 4 ... 20 mA 1																			
AD7	Pressure sensor with operational status indicator, plug M8, threshold value comparator, PNP, N/O contact 1																			
AD9	Pressure sensor with operational status indicator, plug M8, window comparator, PNP, N/O contact 1																			
Tamper protection																				
–	No tamper protection																			
MK	Full cover																			
Flow direction																				
–	From left to right																			
Z	From right to left																			

1 Measuring range max. 10 bar.

Ordering – Product options

<p>Configurable product</p>	<p>This product and all its options can be ordered using the configurator.</p>	<p>The configurator can be found under Products on the DVD or www.festo.com/catalogue/...</p>	<p>Enter the type code in the search field.</p>
------------------------------------	---	---	---

Order code – MS9

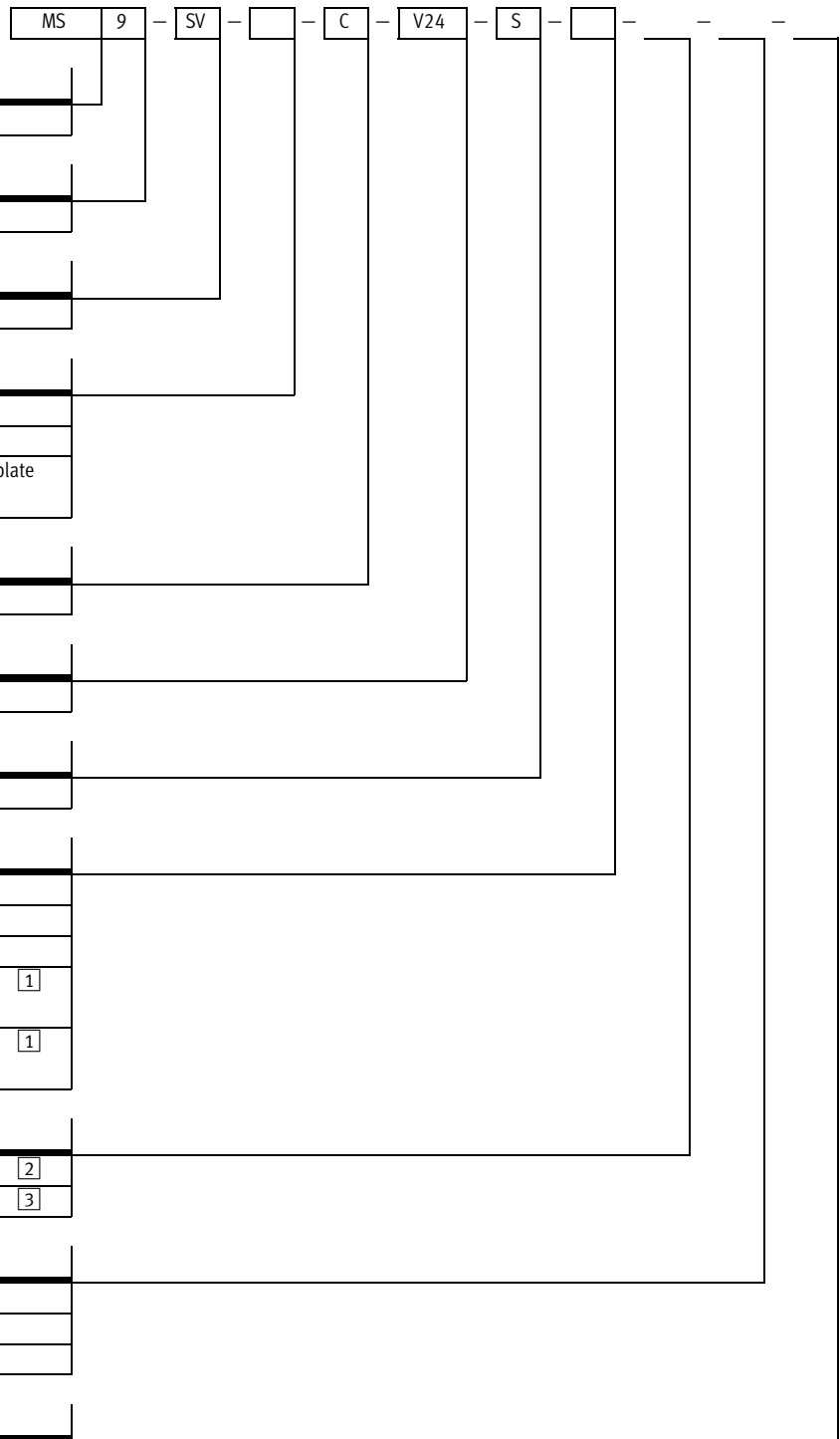

Series	
MS	Standard service unit

Size	
9	Grid dimension 90 mm

Type	
SV	Soft-start/quick exhaust valve

Pneumatic connection	
3/4	Female thread G3/4
1	Female thread G1
G	Module without connecting thread, without connecting plate Connecting plates → 889

Performance Level	
C	Category 1, 1-channel, to EN ISO 13849-1

Supply voltage	
V24	24 V DC (pin allocation to EN 175301), 16 bar

Silencer	
S	Silencer

Pressure gauge/pressure gauge alternatives	
VS	Cover plate
AG	MS pressure gauge
A4	Adapter plate for EN pressure gauge 1/4
AD7	Pressure sensor with operational status indicator, plug M8, threshold value comparator, PNP, N/O contact 1
AD9	Pressure sensor with operational status indicator, plug M8, window comparator, PNP, N/O contact 1

Alternative pressure gauge scale	
-	No pressure gauge scale 2
BAR	Bar 3

Tamper protection	
-	No tamper protection
MH	Cover for manual override only
MK	Full cover

Flow direction	
-	From left to right
Z	From right to left

- 1 Measuring range max. 10 bar.
- 2 Not with MS pressure gauge AG.

- 3 Only with MS pressure gauge AG.

★ Quick ordering

Part No.	Type
MS6	
8001469	MS6-SV-1/2-C-10V24-S

Part No.	Type
MS9	
570737	MS9-SV-G-C-V24-S-VS

Soft-start/quick exhaust valves MS-SV-C, MS series

FESTO

Accessories – MS6

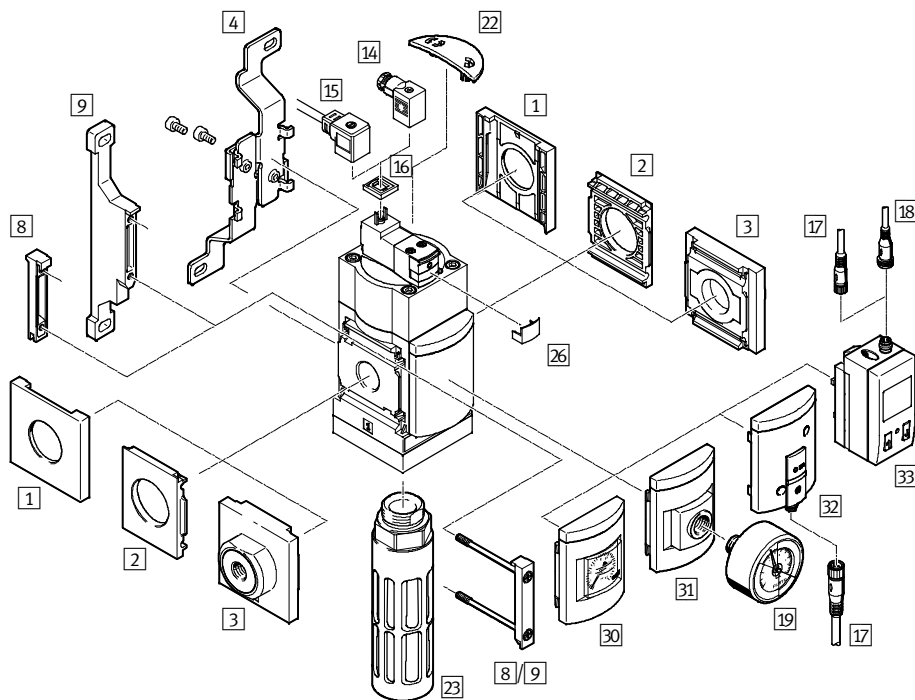

Accessories	→ Page/online
1 Cover cap MS6-END	889
2 Mounting plate MS6-AEND	889
3 Connecting plate MS6-AG...	889
4 Mounting bracket MS6-WB ¹⁾	889
8 Module connector MS6-MV	889
9 Mounting bracket MS6-WP ²⁾	889
14 Plug socket MSSD-EB	890
15 Plug socket with cable KMEB	890
16 Illuminating seal MEB-LD	890
17 Connecting cable NEBU-M8...-LE3	890
18 Connecting cable NEBU-M12...-LE4	890
19 Pressure gauge MA	891
22 Cover MS6-SV-C-MK	891
23 Silencer U	891

Accessories	→ Page/online
26 Locking clip CPV18-HV	891
30 MS pressure gauge AG	865
31 Adapter plate A4 for EN pressure gauge 1/4	865
32 Pressure sensor with operational status indicator AD7/AD9	865
33 Pressure sensor with LCD display AD1/AD3	865
- Mounting bracket MS6-WPB ²⁾	889
- Mounting bracket MS6-WPE ²⁾	889
- Mounting bracket MS6-WPM ²⁾	889
- Module connector MS6-RMV	892
- Module connector MS4-6-AMV	892
- Module connector MS6-9-ARMV	892
- Power supply module MS6-E-IPM	ms*-e-ipm*
- Branching module MS6-A-IPM	ms*-a-ipm*

1) Mounting component for individual device.

2) Mounting and connecting component for combination or for individual device with connecting plate MS6-AG...
3)/with mounting plate MS6-AEND **2**).

Accessories – MS9

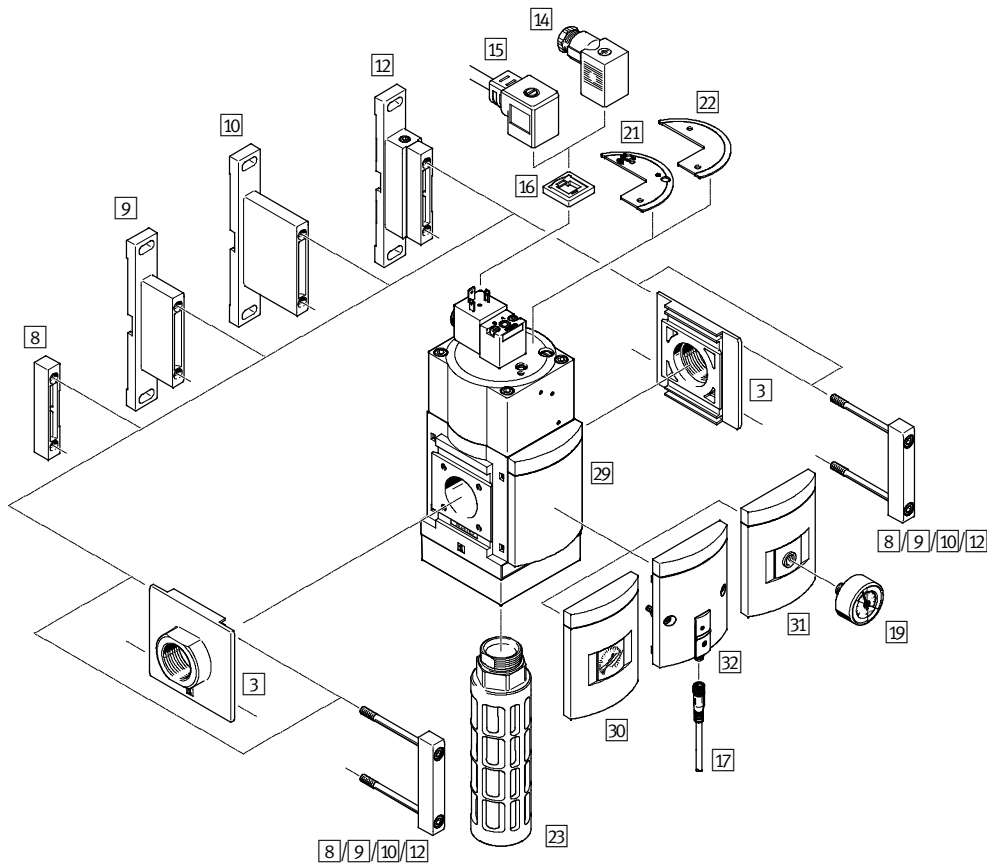

Accessories	→ Page/online
3 Connecting plate MS9-AG... ¹⁾	889
8 Module connector MS9-MV ¹⁾	889
9 Mounting bracket MS9-WP	889
10 Mounting bracket MS9-WPB	889
12 Mounting bracket MS9-WPM ¹⁾	889
14 Plug socket MSSD-C	890
15 Plug socket with cable KMC	890
16 Illuminating seal MC-LD	890
17 Connecting cable NEBU-M8...-LE3	890
19 Pressure gauge MA	891

Accessories	→ Page/online
21 Cover MS9-SV-MH	891
22 Cover MS9-SV-MK	891
23 Silencer U	891
29 Cover plate VS	866
30 MS pressure gauge AG	866
31 Adapter plate A4 for EN pressure gauge 1/4	866
32 Pressure sensor with operational status indicator AD7/AD9	866
- Module connector MS9-RMV	892
- Module connector MS6-9-ARMV	892
- Module connector MS9-12-ARMV	892

1) Not suitable for individual devices with connecting thread G3/4 or G1.

Branching modules MS-FRM, MS series



- Pneumatic manifold with 4 connections
- Can be used as an intermediate distributor for varying air qualities
- 4 sizes:
MS4 – grid dimension 40 mm, MS6 – grid dimension 62 mm, MS9 – grid dimension 90 mm, MS12 – grid dimension 124 mm
- Selected types in accordance with the ATEX Directive for explosive atmospheres → www.festo.com/catalogue/ex

→ www.festo.com/catalogue/ms*-frm

Product range overview

Size	Pneumatic connection	Product options									
		VS	AG	A8	A4	AD...	BAR	X	Y	M12	Z
4	1/8, 1/4	-1)	■	■	■	■	-	■	■	■	■
6	1/4, 3/8, 1/2	-1)	■	-	■	■	-	■	■	■	■
9	3/4, 1, G	■	■	-	■	■	■	■	■	■	■
12	G	-1)	-	-	-	-	-	-	-	-	-

1) Cover plate included in the basic configuration by default.

Product options

1/8	Female thread G1/8	VS	Cover plate	AD4	Pressure sensor with LCD display, plug M12, 1 switching output NPN, 4-pin, analogue output 4 ... 20 mA	X	Pressure switch with display, plug socket, EN 175301, type A, cube
1/4	Female thread G1/4	AG	MS pressure gauge	AD7	Pressure sensor with operational status indicator, plug M8, threshold value comparator, PNP, N/O contact	Y	Pressure switch without display, plug socket, EN 175301, type A, cube
3/8	Female thread G3/8	A8	Adapter plate for EN pressure gauge 1/8, without pressure gauge	AD8	Pressure sensor with operational status indicator, plug M8, threshold value comparator, PNP, N/C contact	M12	Pressure switch without display, plug socket, round, M12, 4-pin
1/2	Female thread G1/2	A4	Adapter plate for EN pressure gauge 1/4, without pressure gauge	AD9	Pressure sensor with operational status indicator, plug M8, window comparator, PNP, N/O contact	WP	Mounting bracket
3/4	Female thread G3/4	RG	Integrated pressure gauge, red/green scale	AD10	Pressure sensor with operational status indicator, plug M8, window comparator, PNP, N/C contact	WPM	Mounting bracket
1	Female thread G1	AD1	Pressure sensor with LCD display, plug M8, 1 switching output PNP, 3-pin			WPB	Mounting bracket for large wall gap
AGA	Connecting plate G1/8	AD2	Pressure sensor with LCD display, plug M8, 1 switching output NPN, 3-pin			WB	Mounting bracket
AGB	Connecting plate G1/4	AD3	Pressure sensor with LCD display, plug M12, 1 switching output PNP, 4-pin, analogue output 4 ... 20 mA			WBM	Mounting bracket
AGC	Connecting plate G3/8			BAR	Pressure gauge scale in bar	EX4	EU certification (II 2GD in accordance with EU Directive 94/9/EC)
AGD	Connecting plate G1/2			PSI	Pressure gauge scale in psi	UL1	UL certification (cULus, ordinary locations for Canada and USA)
AGE	Connecting plate G3/4			MPA	Pressure gauge scale in Mpa	Z	Flow direction from right to left
AGF	Connecting plate G1						
AGG	Connecting plate G1 1/4						
AGH	Connecting plate G1 1/2						
AGI	Connecting plate G2						
G	Module without connecting thread, without connecting plate						
I	Integrated non-return function						

Technical data

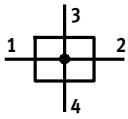

Download CAD data → www.festo.com

Technical data		MS4								MS6			MS9			MS12	
Size		MS4		MS6			MS9			MS12							
Pneumatic connection 1, 2		G1/8	G1/4	G1/4	G3/8	G1/2	G3/4	G1	- ¹⁾	- ¹⁾							
Pneumatic connection 3		G1/4		G1/2			G1			G2							
Pneumatic connection 4		G1/4		G1/2			G1			G1							
Design		Branching module															
Type of mounting		Via accessories															
		In-line installation															
Mounting position		Any															
Pressure indicator	AG	Via pressure gauge for displaying output pressure													-		
	AD1/AD3	Via pressure sensor for displaying output pressure via LCD display and electrical output									-			-			
	AD7/AD9	Via pressure sensor for displaying output pressure via operational status indicator and electrical output													-		
Length [mm]	Standard	54			76			109			124 (134) ²⁾						
	With MS pressure gauge AG	65			77			109			-						
	With adapter plate A8/A4	59			79			110			-						
	With pressure sensor AD1/AD3	83			103			-			-						
	With pressure sensor AD7/AD9	59			79			112			-						
	With pressure switch X/Y	63			76			109			-						
Width [mm]		40			62			104		90		124					
		40			62			104		90		124					
Height [mm]	Standard	60			87			122			122						
	With pressure switch X/Y/M12	153			187			227			-						

- 1) Module without connecting thread/without connecting plate. The connecting plate must be ordered separately as an accessory → 889.
 2) Value in brackets with blanking screws.

Standard nominal flow rate q_{nN}

Standard nominal flow rate q_{nN}		MS4		MS6			MS9			MS12	
Size		MS4		MS6			MS9			MS12	
Pneumatic connection 1, 2		G1/8	G1/4	G1/4	G3/8	G1/2	G3/4	G1	- ³⁾	- ³⁾	
$q_{nN1 \rightarrow 2}$ [l/min]	In main flow direction ⁴⁾	1,800	4,600	4,200	9,200	14,700	25,000	45,000	10,000	25,000 ... 42,000	
									...	50,000	
$q_{nN1 \rightarrow 3}$ [l/min]	Outlet at top ⁴⁾	1,600	1,500	6,000	4,700	4,400	13,000			-	
$q_{nN1 \rightarrow 4}$ [l/min]	Outlet at bottom ⁴⁾	1,700	1,500	6,400	4,800	4,600	13,000			-	

- 3) Dependent on the connecting plate selected, must be ordered separately as an accessory → 889.
 4) Measured at $p_1 = 6$ bar and $p_2 = 5$ bar, $\Delta p = 1$ bar.

Operating conditions

Operating conditions		MS4		MS6			MS9			MS12		
Size		MS4		MS6			MS9			MS12		
Pressure switch		-	X/Y/M12	-	X/Y/M12	-	X/Y/M12	-	X/Y/M12			
Operating medium		Compressed air to ISO 8573-1:2010 [7:4:4]									Compressed air to ISO 8573-1:2010 [-:-:-]	
		Inert gases						-				
Note on operating/pilot medium		Lubricated operation possible (in which case lubricated operation will always be required)									-	
Operating pressure [bar]		0 ... 14 (0 ... 10) ⁵⁾	0 ... 12 (0 ... 10) ⁵⁾	0 ... 20 (0 ... 10) ⁵⁾	0 ... 12 (0 ... 10) ⁵⁾	0 ... 20 (0 ... 10) ⁵⁾	0 ... 12 (0 ... 10) ⁵⁾	0 ... 20 (0 ... 10) ⁵⁾	0 ... 12 (0 ... 10) ⁵⁾	0 ... 20		
Ambient temperature [°C]		-10 ... +60 (0 ... +50) ⁵⁾									-10 ... +60	

- 5) Value in brackets applies to MS4/MS6/MS9-FRM with pressure sensor AD...

Branching modules MS-FRM, MS series

Technical data

Materials	
Housing	Die-cast aluminium
Seals	NBR

Order code – MS4/MS6

Series		MS	FRM
MS	Standard service unit		
Size			
4	Grid dimension 40 mm		
6	Grid dimension 62 mm		
Type			
FRM	Branching module		
Pneumatic connection			
MS4			
1/8	Thread G1/8		
1/4	Thread G1/4		
MS6			
1/4	Thread G1/4		
3/8	Thread G3/8		
1/2	Thread G1/2		
Pressure gauge/adaptor plate			
–	Cover plate		
AG	MS pressure gauge, bar		
A8	Adapter plate for EN pressure gauge 1/8 (MS4 only)		
A4	Adapter plate for EN pressure gauge 1/4		
AD1	Pressure sensor with LCD display, plug M8, 1 switching output PNP, 3-pin [1]		
AD3	Pressure sensor with LCD display, plug M12, 1 switching output PNP, 4-pin, analogue output 4 ... 20 mA [1]		
AD7	Pressure sensor with operational status indicator, plug M8, threshold value comparator, PNP, N/O contact [1]		
AD9	Pressure sensor with operational status indicator, plug M8, window comparator, PNP, N/O contact [1]		
Pressure switch PEV			
–	Without pressure switch PEV		
X	Pressure switch PEV with display, plug socket, EN 175301, type A, cube [2]		
Y	Pressure switch PEV without display, plug socket, EN 175301, type A, cube [2]		
M12	Pressure switch PEV without display, plug socket, round, M12, 4-pin [2]		
Flow direction			
–	From left to right		
Z	From right to left		

[1] Measuring range max. 10 bar.

[2] Max. permissible operating pressure p1 = 12 bar.

Order code – MS9

		MS	9	-	FRM	-		-		-		-		-		-	
Series																	
MS	Standard service unit																
Size																	
9	Grid dimension 90 mm																
Type																	
FRM	Branching module																
Pneumatic connection																	
3/4	Thread G3/4																
1	Thread G1																
G	Module without connecting thread, without connecting plate Connecting plates → 889																
Pressure gauge/pressure gauge alternatives																	
VS	Cover plate																
AG	MS pressure gauge																
A4	Adapter plate for EN pressure gauge 1/4																
AD7	Pressure sensor with operational status indicator, plug M8, threshold value comparator, PNP, N/O contact														1		
AD9	Pressure sensor with operational status indicator, plug M8, window comparator, PNP, N/O contact														1		
Alternative pressure gauge scale																	
-	No pressure gauge scale														2		
BAR	Bar														3		
Pressure switch																	
-	Without pressure switch PEV																
X	Pressure switch PEV with display, plug socket, EN 175301, type A, cube														4		
Y	Pressure switch PEV without display, plug socket, EN 175301, type A, cube														4		
M12	Pressure switch PEV without display, plug socket, round, M12, 4-pin														4		
Flow direction																	
-	From left to right																
Z	From right to left																

1 Measuring range max. 10 bar.
 2 Not with MS pressure gauge AG.

3 Only with MS pressure gauge AG.
 4 Max. permissible operating pressure p1 = 12 bar.

Order code – MS12

	MS	12	–	FRM	–	G
Series						
MS	Standard service unit					
Size						
12	Grid dimension 124 mm					
Type						
FRM	Branching module					
Pneumatic connection						
G	Module without connecting thread, without connecting plate Connecting plates → 889					

Ordering – Product options

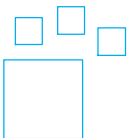

Configurable product

This product and all its options can be ordered using the configurator.

The configurator can be found under Products on the DVD or
→ www.festo.com/catalogue/...

Enter the type code in the search field.

Accessories – MS4/MS6

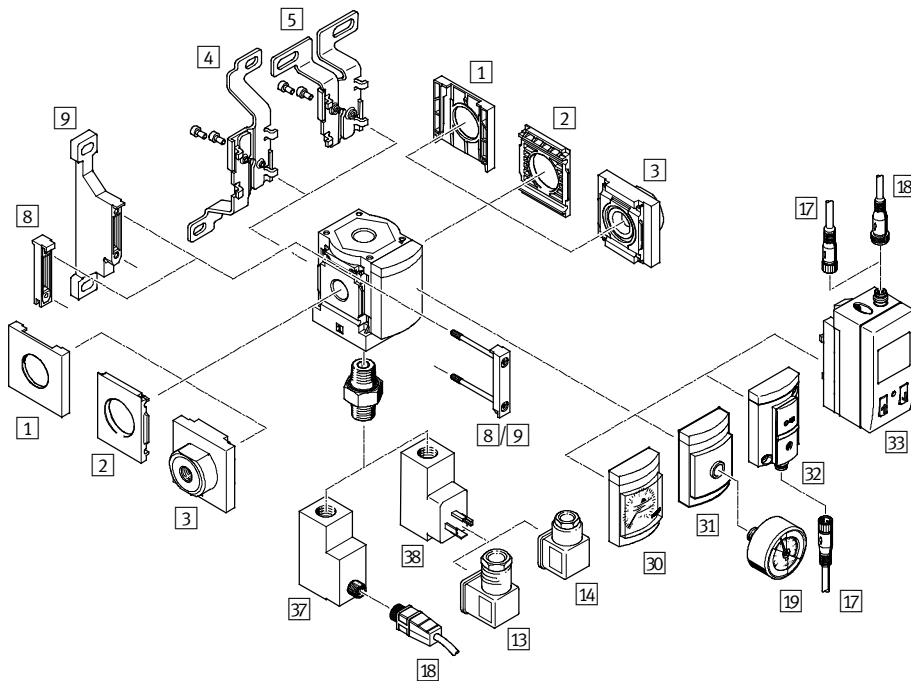

Accessories	→ Page/online
1 Cover cap MS4/6-END	889
2 Mounting plate MS4/6-AEND	889
3 Connecting plate MS4/6-AG...	889
4 Mounting bracket MS4/6-WB ¹⁾	889
5 Mounting bracket MS4-WBM ¹⁾	889
8 Module connector MS4/6-MV	889
9 Mounting bracket MS4/6-WP ²⁾	889
13 Angled plug socket PEV-1/4-WD-LED	890
14 Plug socket MSSD-C-4P	890
17 Connecting cable NEBU-M8...-LE3	890
18 Connecting cable NEBU-M12...-LE4	890
19 Pressure gauge MA	891
30 MS pressure gauge AG	884

1) Mounting component for individual device.

Accessories	→ Page/online
31 Adapter plate A8/A4 for EN pressure gauge 1/8/1/4	884
32 Pressure sensor without display AD7/AD9	884
33 Pressure sensor with display AD1/AD3	884
37 Pressure switch M12	884
38 Pressure switch X/Y	884
- Mounting bracket MS4/6-WPB ²⁾	889
- Mounting bracket MS4/6-WPE ²⁾	889
- Mounting bracket MS4/6-WPM ²⁾	889
- Module connector MS4/6-RMV	892
- Module connector MS4/6-AMV	892
- Module connector MS6-9-ARMV	892
- Power supply module MS4/6-E-IPM	ms*-e-ipm*
- Branching module MS4/6-A-IPM	ms*-a*ipm*

2) Mounting and connecting component for combination or for individual device with connecting plate MS4/6-AG... [3]/with mounting plate MS4/6-AEND [2].

Branching modules MS-FRM, MS series

Accessories – MS9

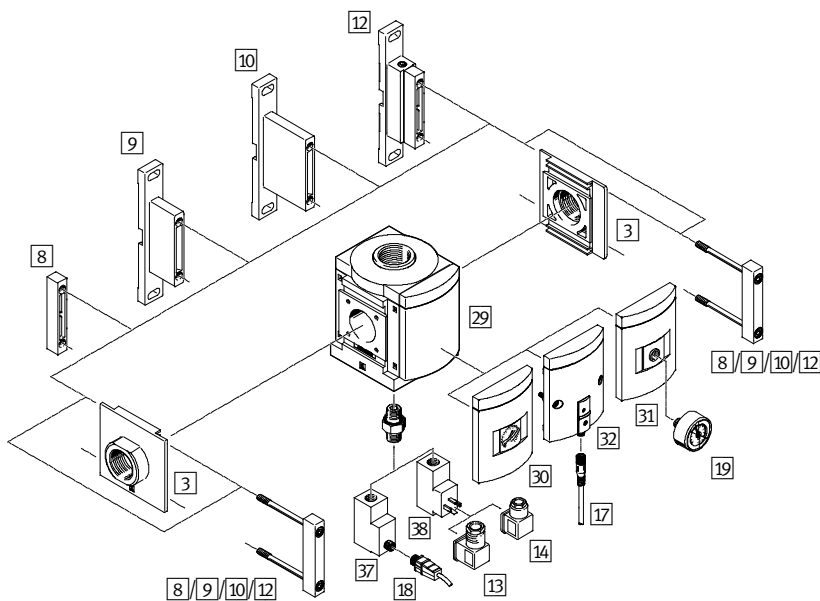

Accessories	→ Page/online
3 Connecting plate MS9-AG... ¹⁾	889
8 Module connector MS9-MV ¹⁾	889
9 Mounting bracket MS9-WP	889
10 Mounting bracket MS9-WPB	889
12 Mounting bracket MS9-WPM ¹⁾	889
13 Angled plug socket PEV-1/4-WD-LED	890
14 Plug socket MSSD-C-4P	890
17 Connecting cable NEBU-M8...-LE3	890
18 Connecting cable NEBU-M12...-LE4	890
19 Pressure gauge MA	891

Accessories	→ Page/online
29 Cover plate VS	885
30 MS pressure gauge AG	885
31 Adapter plate A4 for EN pressure gauge 1/4	885
32 Pressure sensor without display AD7/AD9	885
37 Pressure switch M12	885
38 Pressure switch X/Y	885
- Module connector MS9-RMV	892
- Module connector MS6-9-ARMV	892
- Module connector MS9-12-ARMV	892

1) Not suitable for individual devices with connecting thread G3/4 or G1.



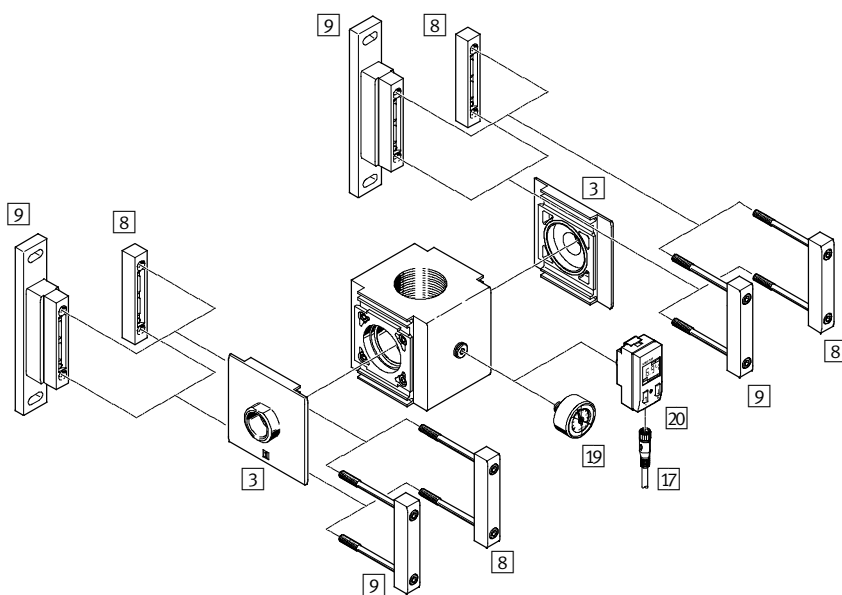



Accessories – MS12



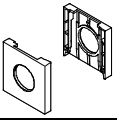

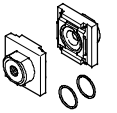
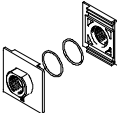
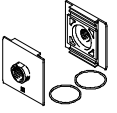
Accessories	→ Page/online
3 Connecting plate MS12-AG...	889
8 Module connector MS12-MV	889
9 Mounting bracket MS12-WP	889
17 Connecting cable NEBU-M8	890





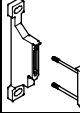
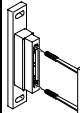
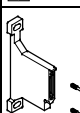
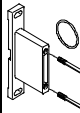
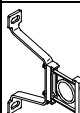
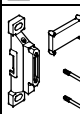
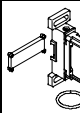
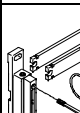

Accessories	→ Page/online
19 Pressure gauge MA	891
20 Pressure sensor SDE1-...-R14 (adapter plate for pneumatic connection included in the scope of delivery)	891
- Module connector MS9-12-ARMV	892

Accessories – Ordering data

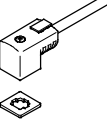
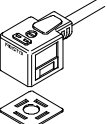

	Size	Part No.	Type
1 Cover cap MS-END Dimensions online: → ms*-end			
	MS4	538779	MS4-END
	MS6	538780	MS6-END
2 Mounting plate MS-AEND Dimensions online: → ms*-aend			
	MS4	542966	MS4-AEND
	MS6	535408	MS6-AEND
3 Connecting plate MS-AG Dimensions online: → ms*-ag*			
	MS4	G1/8	526068 MS4-AGA
		G1/4	526069 MS4-AGB
		G3/8	526070 MS4-AGC
	MS6	G1/4	526080 MS6-AGB
		G3/8	526081 MS6-AGC
G1/2		526082 MS6-AGD	
	MS9	G1/2	552954 MS9-AGD
		G3/4	★ 552955 MS9-AGE
	G1	★ 552956 MS9-AGF	
	G1 1/4	★ 552957 MS9-AGG	
	G1 1/2	★ 552958 MS9-AGH	
	MS12	G1	537135 MS12-AGF
		G1 1/4	537136 MS12-AGG
		G1 1/2	537137 MS12-AGH
		G2	537138 MS12-AGI
4 Mounting bracket MS-WB Dimensions online: → ms*-wb			
	MS4	532185	MS4-WB
	MS6	532196	MS6-WB
5 Mounting bracket MS-WBM Dimensions online: → ms*-wbm			
	MS4	526062	MS4-WBM
6 Mounting bracket MS-WR Dimensions online: → ms*-wr			
	MS4	526064	MS4-WR
	MS6	526075	MS6-WR
7 Hex nut MS-WRS			
	MS4	532187	MS4-WRS
	MS6	532188	MS6-WRS

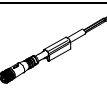
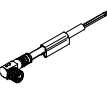
	Size	Part No.	Type
8 Module connector MS-MV For connecting modules			
	MS4	★ 532798	MS4-MV
	MS6	★ 532799	MS6-MV
	MS9	★ 552950	MS9-MV
	MS12	537134	MS12-MV
Module connector MS-MVM For connecting the modules with rotary knob underneath			
	MS4	★ 532800	MS4-MVM
	MS6	★ 532801	MS6-MVM
9 Mounting bracket MS-WP Dimensions online: → ms*-wp			
	MS4	★ 532184	MS4-WP
	MS6	★ 532195	MS6-WP
	MS9	★ 552947	MS9-WP
	MS12	537133	MS12-WP
10 Mounting bracket MS-WPB Dimensions online: → ms*-wpb			
	MS4	For large wall gap	★ 526063 MS4-WPB
	MS6	For large wall gap	★ 526074 MS6-WPB
	MS9	For large wall gap	★ 552949 MS9-WPB
11 Mounting bracket MS-WPE Dimensions online: → ms*-wpe			
	MS4	For large wall gap	558869 MS4-WPE
	MS6	For large wall gap	1025936 MS6-WPE
12 Mounting bracket MS-WPM Dimensions online: → ms*-wpm			
	MS4	For clearance 40 mm	★ 526060 MS4-WPM-D
		For clearance 80 mm	526061 MS4-WPM-2D
	MS6	For clearance 62 mm	★ 526073 MS6-WPM-D
		For clearance 124 mm	532186 MS6-WPM-2D
	MS9	For clearance 90 mm or 180 mm	★ 552948 MS9-WPM

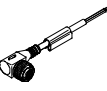

Accessories – Ordering data



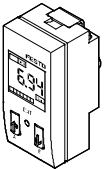

Description		Part No.	Type			
13 Angled plug socket PEV-¼-WD-LED		Technical data online: → pev				
	For pressure switch PEV	4-pin, 15 ... 30 V DC	Yellow LED			
		4-pin, ≤ 230 V AC ≤ 180 V DC	Yellow LED			
		164274	PEV-¼-WD-LED-24			
		164275	PEV-¼-WD-LED-230			
14 Plug socket MSSD		Technical data online: → mssd				
	For pressure switch PEV		171157 MSSD-C-4P			
	For MS4/6-EE and MS6-SV-C	3-pin	Screw terminal			
		4-pin	Insulation displacement connector			
	For MS9/12-EE and MS9-SV-C	3-pin	Screw terminal			
4-pin		Insulation displacement connector				
		151687	MSSD-EB			
		192745	MSSD-EB-S-M14			
		34583	MSSD-C			
		192748	MSSD-C-S-M16			
15 Plug socket with cable KMEB/KMC		Technical data online: → km				
	For MS4/6-EE and MS6-SV-C	2-pin, 24 V DC	LED	2.5 m	547268	KMEB-3-24-2,5-LED
			–	5 m	547269	KMEB-3-24-5-LED
		3-pin, 24 V DC	LED	2.5 m	547270	KMEB-3-24-2,5
			–	5 m	547271	KMEB-3-24-5
	For MS9/12-EE and MS9-SV-C	3-pin, 24 V DC	LED	2.5 m	151688	KMEB-1-24-2,5-LED
			–	5 m	151689	KMEB-1-24-5-LED
		3-pin, 230 V AC	LED	10 m	193457	KMEB-1-24-10-LED
			–	2.5 m	151690	KMEB-1-230AC-2,5
	3-pin, 24 V DC	LED	5 m	151691	KMEB-1-230AC-5	
		–	2.5 m	30931	KMC-1-24DC-2,5-LED	
		–	5 m	30933	KMC-1-24DC-5-LED	
	3-pin, 230 V AC	LED	10 m	193459	KMC-1-24-10-LED	
		–	2.5 m	30932	KMC-1-230AC-2,5	
		–	5 m	30934	KMC-1-230AC-5	
16 Illuminating seal MEB-LD/MC-LD		Technical data online: → meb				
	For plug socket with cable KMEB and plug socket MSSD-EB	12 ... 24 V DC	151717	MEB-LD-12-24DC		
		230 V DC/AC ±10%	151718	MEB-LD-230AC		
	For plug socket with cable KMC and plug socket MSSD-C	12 ... 24 V DC	19145	MC-LD-12-24DC		
		230 V DC/AC ±10%	19146	MC-LD-230AC		
17 Connecting cable NEBU-M8		Technical data → 950				
	M8x1, 3-pin	2.5 m	★	541333	NEBU-M8G3-K-2.5-LE3	
		5 m	★	541334	NEBU-M8G3-K-5-LE3	
	M8x1, 4-pin	2.5 m		541342	NEBU-M8G4-K-2.5-LE4	
		5 m		541343	NEBU-M8G4-K-5-LE4	
	M8x1, 3-pin	2.5 m	★	541338	NEBU-M8W3-K-2.5-LE3	
		5 m	★	541341	NEBU-M8W3-K-5-LE3	
	M8x1, 4-pin	2.5 m		541344	NEBU-M8W4-K-2.5-LE4	
		5 m		541345	NEBU-M8W4-K-5-LE4	
18 Connecting cable NEBU-M12		Technical data → 950				
	M12x1, 3-pin	2.5 m		541363	NEBU-M12G5-K-2.5-LE3	
		5 m		541364	NEBU-M12G5-K-5-LE3	
	M12x1, 4-pin	2.5 m		550326	NEBU-M12G5-K-2.5-LE4	
		5 m		541328	NEBU-M12G5-K-5-LE4	
	M12x1, 3-pin	2.5 m		541367	NEBU-M12W5-K-2.5-LE3	
		5 m		541370	NEBU-M12W5-K-5-LE3	
	M12x1, 4-pin	2.5 m		550325	NEBU-M12W5-K-2.5-LE4	
		5 m		541329	NEBU-M12W5-K-5-LE4	

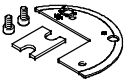

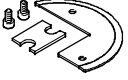
Accessories – Ordering data

	Connection	Indicating range	Part No.	Type
19 Pressure gauge MA Technical data online: → ma				
EN 837-1				
	R $\frac{1}{8}$	0 ... 25 bar	526167	MA-40-25- $\frac{1}{8}$ -EN
	R $\frac{1}{4}$	0 ... 16 bar	187080	MA-40-16-R $\frac{1}{4}$ -EN
		0 ... 25 bar	187081	MA-40-25-R $\frac{1}{4}$ -EN
	G $\frac{1}{4}$	0 ... 16 bar	183901	MA-40-16-G $\frac{1}{4}$ -EN
EN 837-1, with red/green range				
	R $\frac{1}{8}$	0 ... 16 bar	525726	MA-40-16-R $\frac{1}{8}$ -E-RG
	R $\frac{1}{4}$	0 ... 16 bar	525729	MA-50-16-R $\frac{1}{4}$ -E-RG

	Connection	Description	Part No.	Type		
20 Pressure sensor SDE1-...-R14 Technical data → 762						
For direct mounting on the service unit with pressure gauge connection (adapter plate for pneumatic connection included in the scope of delivery)						
	Male thread R $\frac{1}{4}$	PNP	M8x1, 3-pin	LCD	192028	SDE1-D10-G2-R14-C-P1-M8
			M8x1, 3-pin	Illuminated LCD	529967	SDE1-D10-G2-R14-L-P1-M8
		2x PNP	M8x1, 4-pin	LCD	192029	SDE1-D10-G2-R14-C-P2-M8
			M8x1, 4-pin	Illuminated LCD	529968	SDE1-D10-G2-R14-L-P2-M8
		PNP, 0 ... 10 V	M8x1, 4-pin	LCD	529957	SDE1-D10-G2-R14-C-PU-M8
			M8x1, 4-pin	Illuminated LCD	529969	SDE1-D10-G2-R14-L-PU-M8



	Size	Description	Part No.	Type
21 Cover MS-SV-MH				
	For MS9-SV-C	Tamper protection for manual override at the soft-start/quick exhaust valve and manual override at the pilot solenoid valve	1457670	MS9-SV-MH
22 Cover MS-SV-MK				
	For MS6-SV-C	Tamper protection for manual override at the soft-start/quick exhaust valve, flow control screw, adjusting screw for pressure switchover point and manual override at the pilot solenoid valve (MS6-SV-...-C-10V24 only)	8001479	MS6-SV-C-MK
	For MS9-SV-C	Tamper protection for manual override at the soft-start/quick exhaust valve, flow control screw, adjusting screw for pressure switchover point and manual override at the pilot solenoid valve	1457669	MS9-SV-MK

	Description	Part No.	Type
23 Silencer U Technical data → 995			
	G $\frac{1}{4}$	★ 6842	U- $\frac{1}{4}$ -B
	G $\frac{1}{2}$	★ 6844	U- $\frac{1}{2}$ -B
	G $\frac{3}{4}$	6845	U- $\frac{3}{4}$ -B
	G1	151990	U-1-B
24 Sensor socket SIE-GD			
	M12x1, 4-pin	18494	SIE-GD
25 Angled socket SIE-WD			
	M12x1, 4-pin	12956	SIE-WD-TR
26 Locking clip CPV18-HV			
	For MS4/6-EE-...-V24 and MS6-SV-C-...-V24	530056	CPV18-HV

	Description	Part No.	Type
27 Manual override AHB-MD/MF/MV			
	For MS12-EE Packaging unit 10 pieces	157651	AHB-MD/MF/MV
28 Padlock LRVS-D			
	–	193786	LRVS-D
Special oil OFSW			
	Packaging unit 1 litre	152811	OFSW-32

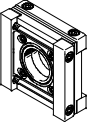
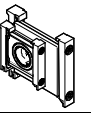
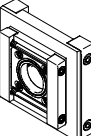
Accessories – Ordering data

	Size	Part No.	Type
Module connector MS-RMV Dimensions online: → ms*-rmv			
For connecting service units turned 90° to the connection axis			
	MS4	543490	MS4-RMV
	MS6	543491	MS6-RMV
	MS9	552952	MS9-RMV
Module connector MS-AMV Dimensions online: → ms*-amv			
For connecting MS4 and MS6 service units into one unit			
	MS4/MS6	543489	MS4-6-AMV
Module connector MS-ARMV Dimensions online: → ms*-armv			
For connecting MS6 and MS9 or MS9 and MS12 service units into one unit, for turning a service unit 90° to the connection axis			
	MS6/MS9	552951	MS6-9-ARMV
	MS9/MS12	552953	MS9-12-ARMV

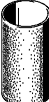
	Size	Part No.	Type
Filter cartridge MS-LFP-C, grade of filtration 5 µm			
	MS4	Colour: blue	534501 MS4-LFP-C
	MS6	Colour: blue	534499 MS6-LFP-C
	MS9		570309 MS9-LFP-C
	MS12		537143 MS12-LFP-C
Filter cartridge MS-LFP-E, grade of filtration 40 µm			
	MS4	Colour: white	534502 MS4-LFP-E
	MS6	Colour: white	534500 MS6-LFP-E
	MS9		570310 MS9-LFP-E
	MS12		537144 MS12-LFP-E





13 Pneumatic connection technology

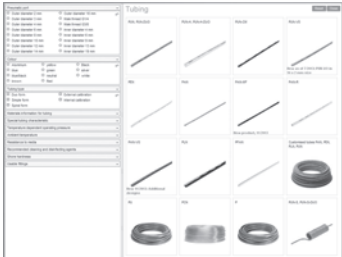





Software tool

Product finder		<p>Simply enter parameters such as working pressure, chemicals and required resistance to cleaning agents and have the program calculate the right tubing for your application.</p>	<p>This tool can be found</p> <ul style="list-style-type: none"> • in the electronic catalogue via the blue icons in the product tree underneath the search field, or • on the DVD under Selection and sizing.
----------------	---	---	--



Standard O.D. tubing

Type	 Plastic tubing, DUO plastic tubing PUN, PUN-DUO	 Plastic tubing, DUO plastic tubing PUN-H, PUN-H-DUO	 Plastic tubing PUN-CM	 Plastic tubing PUN-V0
O.D.	3 ... 16 mm	2 ... 16 mm	4 ... 12 mm	4 ... 16 mm
I.D.	2.1 ... 11 mm	1.2 ... 11 mm	2.5 ... 8 mm	2 ... 11.8 mm
Temperature-dependent operating pressure	-0.95 ... 10 bar	-0.95 ... 10 bar	-0.95 ... 10 bar	-0.95 ... 10 bar
Ambient temperature	-35 ... 60 °C	-35 ... 60 °C	-35 ... 60 °C	-35 ... 60 °C
Description	<ul style="list-style-type: none"> • Highly flexible plastic tubing • Polyurethane • RoHS-compliant • Operating medium: compressed air, vacuum • Suitable for use with energy chains • High resistance to stress cracks • Also in the form of DUO plastic tubing 	<ul style="list-style-type: none"> • Polyurethane • Also in the form of DUO plastic tubing • Operating medium: compressed air, vacuum • Approved for use in the food industry • High resistance to microbes and hydrolysis • Suitable for use with energy chains 	<ul style="list-style-type: none"> • Highly flexible plastic tubing, antistatic, electrically conductive • Polyurethane • Operating medium: compressed air, vacuum • High resistance to UV radiation • Suitable for use with energy chains 	<ul style="list-style-type: none"> • Highly flexible single-sheath plastic tubing • Flame retardant to UL 94 V0 ... V2 • For use in the immediate vicinity of welding applications • Polyurethane • Operating medium: compressed air, vacuum • High resistance to microbes and hydrolysis
→ Page/online	904	905	pun-cm	pun-v0



Standard O.D. tubing

Type	 Plastic tubing PEN	 Plastic tubing PAN	 Plastic tubing PAN-R	 Plastic tubing PAN-V0
O.D.	4 ... 16 mm	4 ... 16 mm	4 ... 16 mm	6 ... 14 mm
I.D.	2.7 ... 10.8 mm	2.9 ... 12 mm	2.5 ... 10 mm	
Temperature-dependent operating pressure	-0.95 ... 10 bar	-0.95 ... 19 bar	-0.95 ... 35 bar	-0.95 ... 12 bar
Ambient temperature	-30 ... 60 °C	-30 ... 80 °C	-30 ... 80 °C	-30 ... 90 °C
Description	<ul style="list-style-type: none"> • Polyethylene • RoHS-compliant • Operating medium: compressed air, vacuum • Good resistance to chemicals and very good resistance to hydrolysis • Resistant to most cleaning agents and lubricants 	<ul style="list-style-type: none"> • High thermal and mechanical load capacities • High resistance to microbes • Polyamide • Operating medium: compressed air, vacuum 	<ul style="list-style-type: none"> • For applications with a high pressure range • High resistance to microbes • Polyamide • Operating medium: compressed air, vacuum 	<ul style="list-style-type: none"> • Double-sheath tubing • PVC, polyamide • Flame retardant to UL 94 V0 • Operating medium: compressed air, vacuum, water, mineral oil • High resistance to microbes and UV radiation • Suitable for use with energy chains
→ Page/online	903	pan	pan-r	pan-v0



Standard O.D. tubing

		
Type	Plastic tubing PLN	Plastic tubing PFAN
O.D.	4 ... 16 mm	4 ... 12 mm
I.D.	2.9 ... 12 mm	2.9 ... 8.4 mm
Temperature-dependent operating pressure	-0.95 ... 14 bar	-0.95 ... 16 bar
Ambient temperature	-30 ... 80 °C	-20 ... 150 °C
Description	<ul style="list-style-type: none"> • High resistance to chemicals, microbes, hydrolysis • Approved for use with food • Resistant to most cleaning agents and lubricants • Operating medium: compressed air, vacuum, water • Polyethylene • RoHS-compliant 	<ul style="list-style-type: none"> • Pneumatic tubing with resistance to high temperatures and chemicals • Approved for use with food • High resistance to chemicals, microbes, UV radiation, hydrolysis, stress cracks • Perfluoroalkoxy alkane • RoHS-compliant • Operating medium: compressed air, vacuum
→ Page/online	pln	pfan

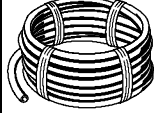
Standard I.D. tubing

			
Type	Plastic tubing PU	Plastic tubing PCN	Rubber hose P
O.D.	11.6 ... 17.6 mm	6.5 mm	13 ... 31 mm
I.D.	9 ... 13 mm	4 mm	6 ... 19 mm
Temperature-dependent operating pressure	-0.95 ... 10 bar	-0.5 ... 0.25 bar	-0.95 ... 16 bar
Ambient temperature	-35 ... 60 °C	-10 ... 60 °C	-20 ... 80 °C
Description	<ul style="list-style-type: none"> • Highly flexible plastic tubing • High resistance to abrasion and kinks • Polyurethane with reinforcing fabric • Operating medium: compressed air, vacuum 	<ul style="list-style-type: none"> • For use with condensate drains on D series service units • PVC with reinforcing fabric • Operating medium: compressed air, water 	<ul style="list-style-type: none"> • P-6 and P-9: nitrile rubber • P-13 and P-19: ethylene propylene rubber, styrene butadiene rubber • With textile reinforcement for female hose connector N • Operating medium: compressed air, vacuum, water
→ Page/online	pu	pcn	p

Spiral tubing

			
Type	Spiral plastic tubing PUN-S, PUN-S-DUO	Spiral plastic tubing PUN-SG	Spiral plastic tubing PPS
O.D.	4 ... 12 mm	9.5 ... 11.7 mm	6.3 ... 7.8 mm
I.D.	2.6 ... 8 mm	6.4 ... 7.9 mm	4.7 ... 6.2 mm
Working length	0.5 ... 6 m	2.4 ... 6 m	7.5 ... 15 m
Temperature-dependent operating pressure	-0.95 ... 10 bar	-0.95 ... 15 bar	-0.95 ... 21.2 bar
Ambient temperature	-35 ... 60 °C	-40 ... 60 °C	-30 ... 80 °C
Description	<ul style="list-style-type: none"> • Highly flexible plastic tubing • Suitable for use with energy chains • Polyurethane • High resistance to UV radiation, stress cracks • Operating medium: compressed air, vacuum • Also in the form of DUO tubing 	<ul style="list-style-type: none"> • Pre-assembled with captive rotatable fittings • Polyurethane, nickel-plated brass, polyacetal • High resistance to microbes, hydrolysis • Operating medium: compressed air, vacuum 	<ul style="list-style-type: none"> • Pre-assembled with 2 rotatable connectors and captive sealing rings OL • Polyamide, brass, galvanised steel • Operating medium: compressed air, vacuum, water • Suitable for use with energy chains • High resistance to microbes • RoHS-compliant
→ Page/online	spiral	spiral	pps



Push-in fittings

Type	Cartridge QSP10, QSPK, QSPKG, QSPLK, QSPLKG, QSPLLK, QSPLKLG	Push-in fitting QSM, QSMC, QSMF, QSMQ, QSMS, QSML, QSMLL, QSMLV, QSMLLV, QSMT, QSMTL, QSMX, QSMY	Push-in fitting QSM-B, QSML-B, QSMT-B	Push-in fitting QS, QSF, QSS, QSSF, QSC, QSH, QSL, QSLL, QSLF, QSLV, QST, QSTF, QSTL, QSW, QSX, QSY, QSYL, QSYLV, QSYTF
Pneumatic connection	QSP...10, 14, 18, 20, for tubing O.D. 3, 4, 6, 8, 10, 12 mm	Male thread G1/8, M3, M5, M6, M6x0.75, M7, M8x0.75, R1/8, female thread M3, M5, push-in sleeve QS-3, QS-4, QS-6, for tubing O.D. 3, 4, 6 mm	Male thread M3, M5, M7, R1/8, for tubing O.D. 3, 4, 6 mm	Male thread G1/8, G1/4, G3/8, G1/2, M5, R1/8, R1/4, R1/2, R3/8, female thread G1/8, G1/4, G3/8, G1/2, push-in sleeve QS-4, QS-6, QS-8, QS-10, QS-12, QS-16, for tubing O.D. 4, 6, 8, 10, 12 and 16 mm
Pneumatic connection, outlet		For tubing O.D. 2, 3, 4, 6 mm	For tubing O.D. 3, 4, 6 mm	Female thread G1/8, G1/4, G3/8, G1/2, for tubing O.D. 4, 6, 8, 10, 12, 16 mm
Operating pressure	-0.95 ... 10 bar			
Temperature-dependent operating pressure		-0.95 ... 14 bar	-0.95 ... 10 bar	-0.95 ... 14 bar
Ambient temperature	-5 ... 60 °C	-10 ... 80 °C	-10 ... 60 °C	-10 ... 80 °C
Description	<ul style="list-style-type: none"> • Plug-in cartridges • Straight or angled design • Suitable for vacuum • Operating medium: compressed air to ISO 8573-1:2010 [7:--:-] 	<ul style="list-style-type: none"> • Quick Star, mini • Compact for maximum component density in confined spaces • Male or female thread with external or internal hex 	<ul style="list-style-type: none"> • Quick Star, mini • Compact for maximum component density in confined spaces • Male thread with external or internal hex 	<ul style="list-style-type: none"> • Quick Star, standard • Male or female thread with external or internal hex • Wide range of variants: wide selection for maximum flexibility in standard applications • Resistant to pressure: economical for pneumatic installations in the high-pressure range
→ Page/online	qsp	910	qsm-b	916



Push-in fittings

Type	Push-in fitting QS-B, QSL-B, QSLL-B, QST-B, QSTL-B, QSY-B	Push-in fitting NPQM	Push-in fitting QS-F, QSF-F, QSSF-F, QSS-F, QSH-F, QSC-F, QSC-F-I, QSL-F, QSLL-F, QST-F, QSY-F	Push-in fitting NPQP
Pneumatic connection	Male thread R1/8, R1/4, R3/8, R1/2, for tubing O.D. 4, 6, 8, 10, 12, 16 mm	G1/8, G1/4, G3/8, G1/2, M5, M7, push-in sleeve QS-4, QS-6, QS-8, QS-10, QS-12, for tubing O.D. 4, 6, 8, 10, 12 mm	G1/8, G1/4, G3/8, G1/2, M5, M7, push-in sleeve QS-4, QS-6, QS-8, QS-10, QS-12, for tubing O.D. 4, 6, 8, 10, 12 mm	Male thread R1/8, R1/4, R3/8, R1/2, push-in sleeve QS-4, QS-6, QS-8, QS-10, QS-12, for tubing O.D. 4, 6, 8, 10, 12 mm
Pneumatic connection, outlet	For tubing O.D. 4, 6, 8, 10, 12, 16 mm	For tubing O.D. 3, 4, 6, 8, 10, 12 mm	For tubing O.D. 4, 6, 8, 10, 12 mm	
Operating pressure		-0.95 ... 16 bar	-0.95 ... 16 bar	-0.95 ... 10 bar
Temperature-dependent operating pressure	-0.95 ... 10 bar			
Ambient temperature	-10 ... 60 °C	-20 ... 70 °C	0 ... 150 °C	-20 ... 60 °C
Description	<ul style="list-style-type: none"> • Quick Star, standard • Male thread with external or internal hex • Economical, suitable for universal use and attractive price • High resistance • Easy to install 	<ul style="list-style-type: none"> • Quick Star, standard • Attractively priced metal push-in fitting • Male or female thread with external or internal hex 	<ul style="list-style-type: none"> • Quick Star, metal • Solid-metal push-in fitting with chrome-plated surface finish • High corrosion resistance (corrosion resistance class 3 according to Festo standard 940070) and chemical resistance • Approved for use in the food and beverage industry • Resistant to welding spatter • Male or female thread with external or internal hex 	<ul style="list-style-type: none"> • Low-cost alternative to stainless steel: resistant to most cleaning agents in combination with tubing PLN • Polypropylene fitting for use in extreme media conditions • Safe for use with food
→ Page/online	qs-b	npqm	qs-f	928



Push-in fittings

Type	 Push-in fitting CRQS, CRQSL, CRQSS, CRQST, CRQSY	 Push-in fitting QS-V0, QSL-V0, QST-V0	 Self-sealing/rotary push-in fitting QSK, QSSK, QSKL, QSR, QSRL
Pneumatic connection	Male thread M5, R1/8, R1/4, R3/8, R1/2, for tubing O.D. 4, 6, 8, 10, 12, 16 mm	G1/8, G1/4, G3/8, G1/2, R1/8, R1/4, R3/8, R1/2, for tubing O.D. 4, 6, 8, 10, 12 mm	Male thread G1/8, G1/4, G3/8, G1/2, M5, R1/8, R1/4, R3/8, R1/2, for tubing O.D. 4, 6, 8, 10, 12 mm
Pneumatic connection, outlet	For tubing O.D. 4, 6, 8, 10, 12, 16 mm	For tubing O.D. 4, 6, 8, 10, 12 mm	For tubing O.D. 4, 6, 8, 10, 12 mm
Operating pressure	-0.95 ... 10 bar	-0.95 ... 10 bar	
Temperature-dependent operating pressure			-0.95 ... 14 bar
Ambient temperature	-15 ... 120 °C	0 ... 60 °C	-10 ... 80 °C
Description	<ul style="list-style-type: none"> • Quick Star, stainless steel • Maximum corrosion resistance (corrosion resistance class 4 according to Festo standard 940 070) and chemical resistance • Approved for use in the food and beverage industry • Male thread with internal and external hex 	<ul style="list-style-type: none"> • Quick Star, flame-retardant • For use in all areas where there is a risk of fire • Reliable even for applications in close proximity to welding splatter • Male thread with external hex 	<ul style="list-style-type: none"> • Quick Star, standard • Male thread with external hex • Push-in fitting that blocks the air flow after the tubing is disconnected • Push-in fitting with swivel connection, rotatable by 360° with max. 500 rpm
→ Page/online	crqs	qs-v0	qsk



Barbed fittings

Type	 Barbed fitting CN, CRCN, FCN, L-PK, LCN, N, RTU, SCN, LCNH, T-PK, TCN, V-PK, Y-PK	 Female hose connector C-P, N-P, N-MS, SK	 Quick connector ACK, CK, QCK, SCK, CV-PK, GCK-KU, LCK, LCKN, TCK, KCK-KU, FCK-KU, MCK, LK, TK, VT
Nominal size	1.3 ... 16.5 mm	2.5 ... 16.5 mm	1.7 ... 12 mm
Pneumatic connection	G1/8, G1/4, G3/8, M3, M5, PK-2, PK-3, PK-4, PK-6	G1/8, G1/4, G3/8, G1/2, G3/4, M5, PK-3, PK-4, PK-6, PK-9, PK-13, PK-19, R1	G1/8, G1/4, G3/8, G1/2, M5, M6x0.75, M10x1, M12x1, M16x1, with union nut: PK-3, PK-4, PK-6, PK-9, PK-13, R1/8, R1/4, R3/8
Operating pressure			-0.9 ... 16 bar
Ambient temperature	0 ... 60 °C		-20 ... 80 °C
Description	<ul style="list-style-type: none"> • With male thread or with male thread and external hex • Stainless steel design • Straight shape, T-shape, L-shape, V-shape, Y-shape 	<ul style="list-style-type: none"> • For hose clip • Female hose connector with or without sealing ring • Hose clip to DIN 3017 • Brass, aluminium design 	<ul style="list-style-type: none"> • Quick connector • Bulkhead quick connector • Sealing cap for plastic tube fittings and barbed connectors • T-distributor • Union nut for CK tube fitting • Multiple distributor • Female or male thread with sealing ring • Aluminium or polymer design
→ Page/online	n_070302f	n_cnp	ck



Threaded fittings

Type	 Adapter NPFV	 Threaded fitting NPFB	 Reducer, sleeve, double nipple D, E, ESK, FR, G, LJK, NPFA, QM, QMR, QSP10, SCM, TJK
Pneumatic connection 1	G1/4	G1/8, G1/4, G3/8, G1/2, G3/4, G1, M5, M7, R1/8, R1/4, R3/8, R1/2, R3/4, R1	G1/8, G1/4, G3/8, G1/2, G3/4, G1, M3, M5, M7, R1/8, R1/4, R3/8, R1/2
Pneumatic connection 2	G1/4, NPT1/4-18	G1/8, G1/4, G3/8, G1/2, G3/4, G1, M5, R1/8, R1/4, R3/8, R1/2, R3/4, R1	G1/8, G1/4, G3/8, G1/2, G3/4, G1, M3, M5, M7, R1/8, R1/4, R3/8, R1/2
Operating pressure	≤ 8 bar	-0.95 ... 40 bar	-0.95 ... 16 bar
Nominal size	6 mm		2.5 ... 18.6 mm
Ambient temperature		-20 ... 150 °C	-10 ... 80 °C
Description	<ul style="list-style-type: none"> • Adapter with filter • From G1/4 to NPT1/4 or G1/4 	<ul style="list-style-type: none"> • Sleeve • Reducing sleeve • Extension • Double nipple • Reducing nipple • L, T, Y or X-fitting • With female and male thread 	<ul style="list-style-type: none"> • Reducing nipple • Reducing sleeve • Double nipple • Distributor block • Female bulkhead fitting • Sleeve
→ Page/online	npfv	npfb	esk

Threaded fittings

Type	 Ring piece, hollow bolt LK, TK, VT	 Blanking plug B
Pneumatic connection 1	M5, G1/8, G1/4, G3/8, PK-3, PK-4, PK-6 with union nut	M3, M5, M7, G1/8, G1/4, G3/8, G1/2, G3/4, G1
Pneumatic connection 2		
Operating pressure	0 ... 10 bar	
Nominal size		
Ambient temperature		
Description	<ul style="list-style-type: none"> • Multiple distributor consisting of hollow bolt VT and ring piece LK or TK • With two to six outlets and one common air feed 	<ul style="list-style-type: none"> • With sealing ring
→ Page/online	lk	b-1

Piping

Type	 Plastic pipe PQ-PA	 Pipe PQ-AL	 Plastic-coated metal tube PM
O.D.	12 ... 28 mm	12 ... 28 mm	6 ... 8 mm
Information on tubing materials	PA	Wrought aluminium alloy	Wrought aluminium alloy, PE
Operating pressure	-0.95 ... 7 bar	-0.95 ... 7 bar	
Temperature-dependent operating pressure			-0.95 ... 30 bar
Ambient temperature	-25 ... 75 °C	-30 ... 75 °C	-29 ... 65 °C
Description	<ul style="list-style-type: none"> • Rigid pipe made from high-quality polyamide • Operating medium: compressed air, vacuum, liquids • Flexible, maintenance-free • Smooth inside wall ensures optimum flow conditions 	<ul style="list-style-type: none"> • Rigid aluminium pipe • Operating medium: compressed air, vacuum, liquids • Corrosion-resistant • Smooth inside wall ensures optimum flow conditions 	<ul style="list-style-type: none"> • Operating medium: compressed air, vacuum • Resistant to deformation • Can be bent straight and reshaped several times without a pipe-bending device and without being damaged • Polyethylene, wrought aluminium alloy • RoHS-compliant
→ Page/online	pq-pa	pq-al	pm





Push-in fittings for piping PQ

Type	 Push-in fitting CQ, CQA, CQC, CQD, CQH, CQL, CQO, CQSR, CQT
Pneumatic connection	Male thread G3/8, G1/2, G3/4, G1, push-in sleeve CQ-12, CQ-15, CQ-18, CQ-22, CQ-28, push-in sleeve QS-12, QS-16, for pipe/tubing O.D. 12, 15, 18, 22, 28 mm
Nominal size	8 ... 24.9 mm
Temperature-dependent operating pressure	-0.95 ... 15 bar
Ambient temperature	-25 ... 75 °C
Description	<ul style="list-style-type: none"> • For pipes PQ-PA, PQ-AL and tubing PAN and PUN • Operating medium: compressed air, vacuum, liquids • Push-in fitting • Push-in connector • Push-in connector with push-in sleeve • Push-in sleeve • Blanking plug • Distributor • Fluid separator • Retaining ring • Releasing tool • Male thread
→ Page/online	cq



Couplings

				
Type	Quick coupling socket, quick coupling plug KDMS6, KDS6, KSS6	Quick coupling socket, quick coupling plug KD1, KD2, KD3, KD4, KD5, KS1, KS2, KS3, KS4, KS5	Multiple connector KSV, KDVF, KDV	Multi-tube connector KM
Pneumatic connection	Male thread G1/4, G3/8, G1/2, G1/8, G1/4, G3/8, G1/2, female thread G1/4, G3/8, G1/2, with union nut: PK-9, PK-13, barbed connector PK-9	Male thread G1/8, G1/4, G1/2, M5, G1/8, G1/4, G3/8, G1/2, female thread G1/8, G1/4, G3/8, G1/2, M5, M3, M5, PK-2, P-13, with union nut: PK-3, PK-4, PK-6, PK-9, PK-13, barbed connector PK-4, PK-6, PK-9	PK-2, PK-3, PK-4, PK-6, for tubing O.D. 3 mm, 4 mm, 6 mm	PK-2, PK-3, PK-4
Standard nominal flow rate	936 ... 1,935 l/min	44 ... 2,043 l/min		
Operating pressure	-0.95 ... 12 bar	-0.95 ... 15 bar	-0.95 ... 16 bar	-0.95 ... 8 bar
Ambient temperature	-10 ... 60 °C	-10 ... 80 °C	-10 ... 60 °C	-10 ... 60 °C
Description	<ul style="list-style-type: none"> • Safety coupling • Shut-off on one side • With male or female thread • Coupling variants: plastic and metal 	<ul style="list-style-type: none"> • Quick connection coupling: for standard applications without safety function • With male or female thread or with barbed fitting or quick connector • Shut-off at one or both ends 	<ul style="list-style-type: none"> • Multi-plug, multi-socket • Terminal plug and terminal socket 	<ul style="list-style-type: none"> • For max. 22 lines • Used as control cabinet outlets
→ Page/online	kdms	kd1	ksv	km





Distributors

				
Type	Multiple distributor QSIV, QSQ, QST3	Multiple distributor QSYTF	Distributor block FR	Rotary distributor GF
Pneumatic connection, supply line	Male thread G1/8, G1/4, G3/8, G1/2, male thread R1/8, R1/4, R3/8, R1/2, for tubing O.D. 6, 8, 10 mm	Male thread G1/8, G1/4, G3/8, G1/2, male thread R1/8, R1/4, R3/8, R1/2	G1/8, G3/8, G1/2, G3/4, R1/8, R1/4, R3/8, R1/2	
Pneumatic connection				Male thread G1/4, G3/8, G1/8, G1/4, G1/2, female thread G1/4, G3/8
Pneumatic connection, outlet	For tubing O.D. 4, 6, 8, 10, 12 mm	Female thread G1/8, G1/4, G3/8, G1/2, for tubing O.D. 6, 8, 10, 12 mm	G1/8, G1/4, G1/2, M3, M5, PK-3, PK-4, R1/8, R1/4, R3/8, R1/2	Female thread M5, G1/8, G1/4, G1/2
No. of supply lines	1	1	1	1
No. of outlets	2 ... 6	3	3 ... 12	2, 4
Max. speed				300 ... 3,000 rpm
Description	<ul style="list-style-type: none"> • Quick Star, standard • Temperature range up to 80 °C • L-shape, T-shape • Rotatable 360° • Connection via threaded connection or push-in connector • Reducing design 	<ul style="list-style-type: none"> • Quick Star, standard • Y-shape • Rotatable 360° • Female and male thread with external hex 	<ul style="list-style-type: none"> • Die-cast aluminium or anodised aluminium • Operating pressure 0 ... 16 bar • 4, 8, 9 or 12 connections 	<ul style="list-style-type: none"> • 4 outlets or 2 axial and radial outlets • Single or multiple rotary distributor • Design with air through-feeds • Operating pressure -0.95 ... +10 bar
→ Page/online	933	qsytf	fr	gf

Protective conduit systems

		
Type	Protective conduit MK, MKG, MKR, MKV	Protective conduit fitting HMZAS, HMZV, MKA, MKGV, MKM, MKRL, MKRS, MKRT, MKRV, MKVM, MKVV, MKY
I.D.	7.5 ... 48 mm	
O.D.	10 ... 52 mm	
Design	Strip-wound metal conduit, internally and externally corrugated all-plastic conduit, separable	
Ambient temperature	-50 ... 220 °C	-40 ... 200 °C
Description	<ul style="list-style-type: none"> • Metal or plastic design • High alternate bending strength • For protecting pneumatic tubing and electrical cables 	<ul style="list-style-type: none"> • Installation kit • Junction box • Adapter connector • Protective conduit fitting • Lock nut • Straight protective conduit fitting, L-shape • Protective conduit connector • Y-distributor
→ Page/online	mkg	mka

Accessories

				
Type	Sealing material CRO, GWB, O, OK, OL	Pipe and tubing cutter PAN, ZDS, ZMS, ZR, ZRS	Pipe clamp PQ	Tubing accessories KK, NPAW, PB, PKB, PKS, QSO, SK
Description	<ul style="list-style-type: none"> • Sealing ring • Sealing ring assortment • Thread sealing tape 	<ul style="list-style-type: none"> • Tubing cutter • Disconnecting pliers • Connecting pliers • Pipe cutter • Pipe and tubing cutter 	<ul style="list-style-type: none"> • For pipes with an O.D. of 12 ... 28 mm 	<ul style="list-style-type: none"> • Tubing strap • Spiral wrap for tubing • Tubing support • Multi-tube holder
→ Page/online	937	zds	pq	npaw

Plastic tubing, standard O.D.



- 9 diameters, standard O.D.
- Also in the form of DUO tubing
- Food industry approval, halogen-free, hydrolysis-resistant, suitable for use with energy chains, free of paint-wetting impairment substances to FN 942 010
- ★ Quick ordering of basic designs → 907

→ www.festo.com/catalogue/tubing

Key features



PUN-DUO/PUN-H-DUO:
Two lengths of plastic tubing are fused together into a tubing pair. For fitting, the paired tubing is separated as required at both ends.

Type	O.D. [mm]	Material	Suitable for use in the food industry	Halogen-free	Suitable for use with energy chains	Approved by the German Techn. Control Board (TÜV)	Resistance				Flexibility	Shore hardness
							Hydrolysis	Chemicals	Microbes	UV radiation		
PEN	4, 6, 8, 10, 12, 14, 16	Polyethylene	-	■	■	■	+++	++	++	++ ¹⁾	++	D 52 ±3
PUN	3, 4, 6, 8, 10, 12, 14, 16	Polyurethane	-	■	■	■	+	-	-	++ ¹⁾	+++	D 52 ±3
PUN-DUO	4, 6, 8, 10	Polyurethane	-	■	■	■	+	-	-	+	++	D 52 ±3
PUN-H	2	Polyurethane	-	■	■	-	++	+	++	++ ¹⁾	+++	A 98 ±3
	3, 4, 6, 8, 10, 12, 14, 16	Polyurethane	■	■	■	■	++	+	++	++ ¹⁾	+++	D 52 ±3
PUN-H-DUO	4, 6, 8, 10	Polyurethane	■	■	■	■	++	+	++	+	++	D 52 ±3

+++ Highly suitable
 ++ Suitable
 + Limited suitability (on request)
 - Not suitable

1) Applies to black colour

Product range overview

Type	O.D. [mm]	Packaging unit [m]	Product options												Page/online		
			Colour														
			SI	BL	SW	GE	GN	RT	BR	WS	NT	BS	TXT	CB		HA	
PEN	4, 6, 8, 10, 12, 14, 16	50, 100, 200, 300, 400, 500	■	■	■	■	■	■	■	■	■	■	-	■	■	■	903
PUN	3, 4, 6, 8, 10, 12, 14, 16	50, 100, 200, 300, 400, 500	■	■	■	■	■	■	■	■	■	■	-	■	■	■	904
PUN-DUO	4, 6, 8, 10	50	■	-	-	-	-	-	-	-	-	-	■	-	-	-	906
PUN-H	2	50	-	-	■	-	-	■	-	-	-	-	-	-	-	-	905
	3, 4, 6, 8, 10, 12, 14, 16	50, 100, 200, 300, 400, 500	■	■	■	■	■	■	■	■	■	■	-	■	■	■	905
PUN-H-DUO	4, 6, 8, 10	50	-	-	-	-	-	-	-	-	-	-	■	-	-	-	906

Product options

SI	Silver	GN	Green	NT	Natural	25	Packaging unit 25 m
BL	Blue	RT	Red	BS	Blue/black	CB	Cardboard box
SW	Black	BR	Brown	TXT	Customer-specific tubing inscription (on request)	HA	Reel
GE	Yellow	WS	White				

Technical data

Technical data		Download CAD data → www.festo.com						
O.D.	[mm]	4	6	8	10	12	14	16
I.D.	[mm]	2.7	4	5.7	7	8.4	9.5	10.8
Min. bending radius	[mm]	10	13.5	22.5	23.5	33	45	57.5
Bending radius relevant for flow rate	[mm]	20	26	35	40	58	80	122

Operating conditions

Operating medium	Compressed air to ISO 8573-1:2010 [7:-:-]
Temperature-dependent operating pressure [bar]	-0.95 ... +10
Ambient temperature [°C]	-30 ... +60

Order code

PEN		-	[]	x	[]	-	[]	-	[]
Type									
PEN	Polyethylene tubing								
O.D. [mm]									
	Wall thickness [mm]								
4	0.75								
6	1								
8	1.25								
10	1.5								
12	1.75								
14	2								
16	2.5								
Colour									
SI	Silver	[1]							
BL	Blue	[1]							
BK	Black								
GE	Yellow	[1]							
GN	Green	[1]							
RT	Red	[1]							
NT	Natural								
Packaging unit [m]									
-	50								
100	100	[2]							
200	200	[3]							
300	300	[4]							
400	400	[5]							
500	500	[6]							

- [1] Not with O.D. 14
 [2] Only with O.D. 16 and colours SI, BL, SW
 [3] Only with O.D. 12 and colours SI, BL, SW

- [4] Only with O.D. 10 and colours SI, BL, SW
 [5] Only with O.D. 8 and colours SI, BL, SW
 [6] Only with O.D. 4, 6 and colours SI, BL, SW

Ordering – Product options

	Configurable product	This product and all its options can be ordered using the configurator.	The configurator can be found under Products on the DVD or → www.festo.com/catalogue/...	Enter the type code in the search field.
---	-----------------------------	--	--	--

Plastic tubing PUN, standard O.D.

Technical data

Technical data		Download CAD data → www.festo.com							
O.D.	[mm]	3	4	6	8	10	12	14	16
I.D.	[mm]	2.1	2.6	4	5.7	7	8	9.8	11
Min. bending radius	[mm]	9	8	16	24	28	33	45	45
Bending radius relevant for flow rate	[mm]	12	17	26.5	37	54	62	84	88

Operating conditions	
Operating medium	Compressed air to ISO 8573-1:2010 [7:-:-]
Temperature-dependent operating pressure [bar]	-0.95 ... +10
Ambient temperature [°C]	-35 ... +60

Order code

PUN

-

x

-

-

Type	
PUN	Polyurethane tubing

O.D. [mm]	
	Wall thickness [mm]
3	0.5
4	0.75
6	1
8	1.25
10	1.5
12	2
14	2
16	2.5

Colour	
SI	Silver
BL	Blue
BK	Black
GE	Yellow 1
GN	Green 1
RT	Red 1

Packaging unit [m]	
-	50
100	100 2
200	200 3
300	300 4
400	400 5
500	500 6

- 1 Not with O.D. 14
- 2 Only with O.D. 16 and colours SI, BL, SW
- 3 Only with O.D. 12 and colours SI, BL, SW
- 4 Only with O.D. 10 and colours SI, BL, SW
- 5 Only with O.D. 8 and colours SI, BL, SW
- 6 Only with O.D. 3, 4, 6 and colours SI, BL, SW

Ordering – Product options

Configurable product

This product and all its options can be ordered using the configurator.

The configurator can be found under Products on the DVD or
[→ www.festo.com/catalogue/...](http://www.festo.com/catalogue/...)

Enter the type code in the search field.

Technical data

Technical data		Download CAD data → www.festo.com								
O.D.	[mm]	2	3	4	6	8	10	12	14	16
I.D.	[mm]	1.2	2.1	2.6	4	5.7	7	8	9.8	11
Min. bending radius	[mm]	5	6	8	10	21	28	33	38	38
Bending radius relevant for flow rate	[mm]	8	12	16	26	37	52	62	78	88

Operating conditions

Operating conditions		Download CAD data → www.festo.com								
O.D.	[mm]	2	3	4	6	8	10	12	14	16
Operating medium		Compressed air to ISO 8573-1:2010 [7:-:-]								
Temperature-dependent operating pressure	[bar]	-0.95 ... +10								
Ambient temperature	[°C]	-35 ... +60								
Suitable for use in the food industry		-	As per manufacturer's declaration							

Order code

Type		PUN - H - [] x [] - [] - []	
PUN	Polyurethane tubing		
Alternative material properties			
H	Hydrolysis-resistant		
O.D. [mm]			
	Wall thickness [mm]		
2	0.4		
3	0.5		
4	0.75		
6	1		
8	1.25		
10	1.5		
12	2		
14	2		
16	2.5		
Colour			
SI	Silver	[1]	[2]
BL	Blue	[1]	
BK	Black		
GE	Yellow	[1]	[2]
GN	Green	[1]	[2]
RT	Red	[2]	
NT	Natural		
Packaging unit [m]			
-	50		
100	100	[3]	
200	200	[4]	
300	300	[5]	
400	400	[6]	
500	500	[7]	

[1] Not with O.D. 2

[2] Not with O.D. 14

[3] Only with O.D. 16 and colours SI, BL, SW, NT

[4] Only with O.D. 12 and colours SI, BL, SW, NT

[5] Only with O.D. 10 and colours SI, BL, SW, NT

[6] Only with O.D. 8 and colours SI, BL, SW, NT

[7] Only with O.D. 3, 4, 6 and colours SI, BL, SW, NT

Ordering – Product options

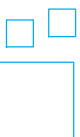

Configurable product

This product and all its options can be ordered using the configurator.

The configurator can be found under Products on the DVD or
→ www.festo.com/catalogue/...

Enter the type code in the search field.

DUO plastic tubing PUN-DUO, standard O.D.

Technical data

Technical data		Download CAD data → www.festo.com							
Type		PUN-DUO				PUN-H-DUO			
O.D.	[mm]	4	6	8	10	4	6	8	10
I.D.	[mm]	2.6	4	5.7	7	2.6	4	5.7	7
Min. bending radius	[mm]	8	16	24	28	8	10	21	28
Bending radius relevant for flow rate	[mm]	17	26.5	37	54	16	26	37	52

Operating conditions		PUN-DUO	PUN-H-DUO
Operating medium		Compressed air to ISO 8573-1:2010 [7:-:-]	
Temperature-dependent operating pressure	[bar]	-0.95 ... +10	
Ambient temperature	[°C]	-35 ... +60	
Suitable for use in the food industry		-	As per manufacturer's declaration

Order code

PUN - x - DUO -

Type	
PUN	Polyurethane tubing
Alternative material properties	
-	Standard
H	Hydrolysis-resistant
O.D. [mm]	
	Wall thickness [mm]
4	0.75
6	1
8	1.25
10	1.5
Tubing type	
DUO	DUO tubing
Colour	
PUN	
SI	Silver
BS	Blue/black
PUN-H	
-	Blue/black

13

Ordering – Product options

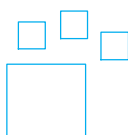

Configurable product

This product and all its options can be ordered using the configurator.

The configurator can be found under Products on the DVD or
[→ www.festo.com/catalogue/...](http://www.festo.com/catalogue/...)

Enter the type code in the search field.

★ Quick ordering

PUN

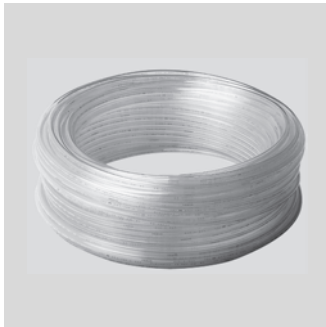

O.D. [mm]	I.D. [mm]	Min. bending radius [mm]	Bending ra- dius relevant for flow rate [mm]	Colour	Part No.	Type	PU ¹⁾
3	2.1	9	21	Silver	152583	PUN-3x0,5-SI	50
				Blue	159660	PUN-3x0,5-BL	50
				Black	159661	PUN-3x0,5-SW	50
4	2.6	8	17	Silver	152584	PUN-4x0,75-SI	50
				Blue	159662	PUN-4x0,75-BL	50
				Black	159663	PUN-4x0,75-SW	50
6	4	16	26.5	Silver	152586	PUN-6x1-SI	50
				Blue	159664	PUN-6x1-BL	50
				Black	159665	PUN-6x1-SW	50
8	5.7	24	37	Silver	152587	PUN-8x1,25-SI	50
				Blue	159666	PUN-8x1,25-BL	50
				Black	159667	PUN-8x1,25-SW	50
10	7	28	54	Silver	152588	PUN-10x1,5-SI	50
				Blue	159668	PUN-10x1,5-BL	50
				Black	159669	PUN-10x1,5-SW	50
12	8	33	62	Silver	152589	PUN-12x2-SI	50
				Blue	159670	PUN-12x2-BL	50
				Black	159671	PUN-12x2-SW	50
14	9.8	45	84	Silver	570389	PUN-14x2-SI	50
				Blue	570390	PUN-14x2-BL	50
				Black	570391	PUN-14x2-SW	50
16	11	45	88	Silver	152590	PUN-16x2,5-SI	50
				Blue	159672	PUN-16x2,5-BL	50
				Black	159673	PUN-16x2,5-SW	50

PUN-H, hydrolysis-resistant

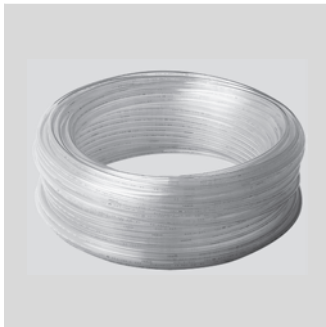

O.D. [mm]	I.D. [mm]	Min. bending radius [mm]	Bending ra- dius relevant for flow rate [mm]	Colour	Part No.	Type	PU ¹⁾
2	1.2	5	8	Black	133039	PUN-H-2x0,4-SW	50
3	2.1	6	12	Blue	197382	PUN-H-3x0,5-BL	50
				Black	197389	PUN-H-3x0,5-SW	50
				Silver	558277	PUN-H-3x0,5-SI	50
4	2.6	8	16	Blue	197383	PUN-H-4x0,75-BL	50
				Black	197390	PUN-H-4x0,75-SW	50
				Silver	558278	PUN-H-4x0,75-SI	50
6	4	10	26	Blue	197384	PUN-H-6x1-BL	50
				Black	197391	PUN-H-6x1-SW	50
				Silver	558279	PUN-H-6x1-SI	50
8	5.7	21	37	Blue	197385	PUN-H-8x1,25-BL	50
				Black	197392	PUN-H-8x1,25-SW	50
				Silver	558280	PUN-H-8x1,25-SI	50
10	7	28	52	Blue	197386	PUN-H-10x1,5-BL	50
				Black	197393	PUN-H-10x1,5-SW	50
				Silver	558281	PUN-H-10x1,5-SI	50
12	8	33	62	Blue	197387	PUN-H-12x2-BL	50
				Black	197394	PUN-H-12x2-SW	50
				Silver	558282	PUN-H-12x2-SI	50
14	9.8	38	78	Blue	570386	PUN-H-14x2-BL	50
				Black	570387	PUN-H-14x2-SW	50
16	11	38	88	Blue	197388	PUN-H-16x2,5-BL	50
				Black	197395	PUN-H-16x2,5-SW	50
				Silver	558283	PUN-H-16x2,5-SI	50

1) Packaging unit in metres

Push-in fittings QS, Quick Star



- Simple and reliable connection and release
- With R, G and metric thread
- Wide range of variants
- Rotatable 360°
- ★ Quick ordering of basic designs → 910

→ www.festo.com/catalogue/quick_star

Key features

QSM, Quick Star, mini



Miniature push-in fittings for high component density in confined spaces. Tubing O.D. of 2, 3, 4 and 6 mm with connecting threads M3, M5, M6, M7, R1/8 and G1/8.

QS, Quick Star



Wide selection of push-in fittings. Tubing O.D. of 4, 6, 8, 10, 12 and 16 mm with connecting threads R1/8 ... R1/2 and G1/8 ... G1/2.

Product range overview

Type	Version	Design	Connection D1					Connection D2		→ Page/ online
			M thread	R thread	G thread	Tubing O.D.	Push-in sleeve ∅	Tubing O.D.		
QSM, Quick Star, mini										
QSM	Push-in fitting	Straight	■	■	■	-	-	■	910	
	Push-in connector		-	-	-	■	■	■	911	
QSMS	Push-in bulkhead connector		-	-	-	■	-	■		
QSMF	Push-in fitting		■	-	-	-	-	■		
QSMP	Push-in fitting		■	-	-	-	-	■	qsmp	
QSMC	Push-in cap		-	-	-	■	-	-	qsmc	
	Blanking plug	-	-	-	-	■	-			
QSML	Push-in fitting	L-shape	■	■	■	-	-	■	912	
	Push-in connector		-	-	-	■	■	■	913	
QSMLV	Push-in fitting		■	-	-	-	-	■		
QSMT	Push-in fitting	T-shape	■	■	■	-	-	■	914	
	Push-in connector		-	-	-	■	-	■		
QSMTL	Push-in fitting		■	■	■	-	-	■		
QSMX	Push-in connector	X-shape	-	-	-	■	-	■	qsmx	
QSMY	Push-in connector	Y-shape	-	-	-	■	-	■	915	

Product range overview

Type	Version	Design	Connection D1					Connection D2		→ Page/ online
			M thread	R thread	G thread	Tubing O.D.	Push-in sleeve Ø	Tubing O.D.		
QS, Quick Star										
QS	Push-in fitting	Straight	-	■	■	-	-	■	916	
	Push-in connector		-	-	-	■	■	■	917	
QSS	Push-in bulkhead connector		-	-	-	-	-	■	918	
QSF	Push-in fitting		-	-	■	-	-	■	qssf qsc	
QSSF	Push-in bulkhead fitting		-	-	■	-	-	■		
QSC	Push-in cap		-	-	-	■	-	-	qsc	
	Blanking plug		-	-	-	-	■	-		
QSH	Push-in sleeve		-	-	-	-	■	-	qsh	
QSL	Push-in fitting		L-shape	-	■	■	-	-	■	919
	Push-in connector			-	-	-	■	■	■	921
QSLF	Push-in fitting	-		-	■	-	-	■	922	
QSLV	Push-in fitting	■		■	■	-	-	■		
QST	Push-in fitting	T-shape	-	■	■	-	-	■	923	
	Push-in connector		-	-	-	■	-	■		
QSTF	Push-in fitting		-	■	■	-	-	■	924	
QSTL	Push-in fitting		-	■	■	-	-	■		
QSW	Push-in fitting	W-shape	-	■	-	-	-	■	925	
	Push-in connector		-	-	-	-	■	■		
QSX	Push-in connector	X-shape	-	-	-	■	-	■	qsx	
QSY	Push-in fitting	Y-shape	■	■	■	-	-	■	926	
	Push-in connector		-	-	-	■	■	■		
QSYL	Push-in fitting		-	■	■	-	-	■	927	
QSYLV	Push-in fitting		-	■	■	-	-	■		
QSYTF	Push-in fitting		-	■	■	-	-	■	qsytf	

Technical data

Operating conditions	
Operating medium	Compressed air to ISO 8573-1:2010 [7:-:-]
Note on operating/pilot medium	Lubricated operation possible
Operating pressure [bar]	-0.95 ... +14
Operating temperature [°C]	-10 ... +80
Materials	
Housing	PBT
Tube retaining claw	High-alloy stainless steel
Releasing ring	POM
Tubing seal	NBR

Push-in fittings QSM, Quick Star, mini

★ Quick ordering

Push-in fitting QSM

Male thread with external hex



Connection D1	Nominal size [mm]	Tubing O.D. D2	Part No.	Type	PU ¹⁾
Metric thread with sealing ring					
M3	0.9	2	133027	QSM-M3-2	10
	0.9	3	153301	QSM-M3-3	10
	1.1	4	153303	QSM-M3-4	10
M5	1.1	2	133028	QSM-M5-2	10
	2	3	153302	QSM-M5-3	10
	2.2	4	153304	QSM-M5-4	10
	2.1	6	153306	QSM-M5-6	10
M6	2.8	6	132600	QSM-M6-6	10
R thread					
R $\frac{1}{8}$	2.9	4	153305	QSM- $\frac{1}{8}$ -4	10
	4.5	6	153307	QSM- $\frac{1}{8}$ -6	10
G thread with sealing ring					
G $\frac{1}{8}$	2.9	4	186264	QSM-G $\frac{1}{8}$ -4	10
	2.8	6	186265	QSM-G $\frac{1}{8}$ -6	10

Push-in fitting QSM-...-I

Male thread with internal hex



Connection D1	Nominal size [mm]	Tubing O.D. D2	Part No.	Type	PU ¹⁾
Metric thread with sealing ring					
M3	1.1	2	133026	QSM-M3-2-I	10
	1.6	3	153312	QSM-M3-3-I	10
	1.5	4	153314	QSM-M3-4-I	10
M5	1.9	3	153313	QSM-M5-3-I	10
	2.5	4	153315	QSM-M5-4-I	10
	2.6	6	153317	QSM-M5-6-I	10
M7	3.1	4	153319	QSM-M7-4-I	10
	4.1	6	153321	QSM-M7-6-I	10
R thread					
R $\frac{1}{8}$	3.1	4	153316	QSM- $\frac{1}{8}$ -4-I	10
	4.1	6	153318	QSM- $\frac{1}{8}$ -6-I	10
G thread with sealing ring					
G $\frac{1}{8}$	3.1	4	186266	QSM-G $\frac{1}{8}$ -4-I	10
	4.1	6	186267	QSM-G $\frac{1}{8}$ -6-I	10

¹⁾ Packaging unit per part

★ Quick ordering

Push-in connector QSM



Tubing O.D. D1	Nominal size [mm]	Tubing O.D. D2	Part No.	Type	PU ¹⁾
3	1.9	3	153323	QSM-3	10
4	2.6	4	153324	QSM-4	10
6	3.7	6	153325	QSM-6	10
Reducing					
3	1.1	2	133029	QSM-3-2	10
4	1.7	3	153326	QSM-4-3	10
6	2.7	4	153327	QSM-6-4	10

Push-in connector QSM-...H

with push-in sleeve



Push-in sleeve Ø D1	Nominal size [mm]	Tubing O.D. D2	Part No.	Type	PU ¹⁾
3	1.1	2	133035	QSM-3H-2	10
4	1.7	3	153328	QSM-4H-3	10
6	2.6	4	153329	QSM-6H-4	10

Push-in bulkhead connector QSMS



Tubing O.D. D1	Nominal size [mm]	Part No.	Type	PU ¹⁾
3	1.7	153375	QSMS-3	10
4	2.2	153376	QSMS-4	10
6	3.7	153377	QSMS-6	10

Push-in fitting QSMF

Female thread with external hex



Connection D1	Nominal size [mm]	Tubing O.D. D2	Part No.	Type	PU ¹⁾
Metric thread with sealing ring					
M3	1.3	3	153308	QSMF-M3-3	10
	2.1	4	153310	QSMF-M3-4	10
M5	1.9	3	153309	QSMF-M5-3	10
	1.8	4	153311	QSMF-M5-4	10

¹⁾ Packaging unit per part

Push-in fittings QSM, Quick Star, mini

★ Quick ordering

Push-in L-fitting QSML

Rotatable 360°, male thread with external hex

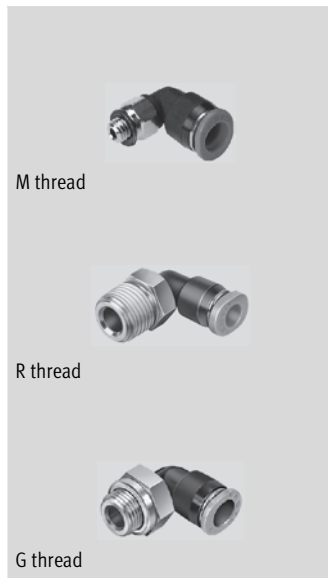

Connection D1	Nominal size [mm]	Tubing O.D. D2	Part No.	Type	PU ¹⁾
Metric thread with sealing ring					
M3	0.8	2	133030	QSML-M3-2	10
	0.8	3	153330	QSML-M3-3	10
	1.3	4	153332	QSML-M3-4	10
M5	0.9	2	133031	QSML-M5-2	10
	1.5	3	153331	QSML-M5-3	10
	1.7	4	153333	QSML-M5-4	10
	2.1	6	153335	QSML-M5-6	10
M7	2	4	186352	QSML-M7-4	10
	2.4	6	186353	QSML-M7-6	10
R thread					
R $\frac{1}{8}$	2.5	4	153334	QSML- $\frac{1}{8}$ -4	10
	3.3	6	153336	QSML- $\frac{1}{8}$ -6	10
G thread with sealing ring					
G $\frac{1}{8}$	2.5	4	186268	QSML-G $\frac{1}{8}$ -4	10
	3.3	6	186269	QSML-G $\frac{1}{8}$ -6	10

Push-in long L-fitting QSMLL

Rotatable 360°, male thread with external hex



Connection D1	Nominal size [mm]	Tubing O.D. D2	Part No.	Type	PU ¹⁾
Metric thread with sealing ring					
M3	0.8	2	133032	QSMLL-M3-2	10
	0.9	3	153337	QSMLL-M3-3	10
	1.1	4	153338	QSMLL-M3-4	10
M5	0.9	2	133033	QSMLL-M5-2	10
	1.5	3	130838	QSMLL-M5-3	10
	2	4	153339	QSMLL-M5-4	10
	2	6	153341	QSMLL-M5-6	10
M7	2	4	186354	QSMLL-M7-4	10
	2.4	6	186355	QSMLL-M7-6	10
R thread					
R $\frac{1}{8}$	2.3	4	153340	QSMLL- $\frac{1}{8}$ -4	10
	3.1	6	153342	QSMLL- $\frac{1}{8}$ -6	10
G thread with sealing ring					
G $\frac{1}{8}$	2.3	4	186270	QSMLL-G $\frac{1}{8}$ -4	10
	3.1	6	186271	QSMLL-G $\frac{1}{8}$ -6	10

1) Packaging unit per part

★ Quick ordering

Push-in L-connector QSML



Tubing O.D. D1	Nominal size [mm]	Part No.	Type	PU ¹⁾
3	1.7	153343	QSML-3	10
4	2.5	153344	QSML-4	10
6	3.4	153345	QSML-6	10

Push-in L-connector QSML-...H
 with push-in sleeve



Push-in sleeve Ø D1	Nominal size [mm]	Tubing O.D. D2	Part No.	Type	PU ¹⁾
3	1.2	3	153346	QSML-3H	10
4	1.9	4	153347	QSML-4H	10
6	3.2	6	153348	QSML-6H	10
Reducing					
4	1.7	3	153349	QSML-4H-3	10
6	1.9	4	153350	QSML-6H-4	10

Push-in L-fitting QSMLV-...-I

Rotatable 360°, male thread with internal hex



Connection D1	Nominal size [mm]	Tubing O.D. D2	Part No.	Type	PU ¹⁾
Metric thread with sealing ring					
M5	1.7	3	130830	QSMLV-M5-3-I	10
	1.8	4	130831	QSMLV-M5-4-I	10
M7	1.9	4	130832	QSMLV-M7-4-I	10
	1.8	6	130833	QSMLV-M7-6-I	10

Push-in long L-fitting QSMLLV-...-I

Rotatable 360°, male thread with internal hex



Connection D1	Nominal size [mm]	Tubing O.D. D2	Part No.	Type	PU ¹⁾
Metric thread with sealing ring					
M5	1.6	3	130834	QSMLLV-M5-3-I	10
	1.8	4	130835	QSMLLV-M5-4-I	10
M7	1.9	4	130836	QSMLLV-M7-4-I	10
	1.9	6	130837	QSMLLV-M7-6-I	10

¹⁾ Packaging unit per part

Push-in fittings QSM, Quick Star, mini

★ Quick ordering

Push-in T-fitting QSMT

Rotatable 360°, male thread with external hex



Connection D1	Nominal size [mm]	Tubing O.D. D2	Part No.	Type	PU ¹⁾
Metric thread with sealing ring					
M3	0.9	3	153351	QSMT-M3-3	10
	1.3	4	153353	QSMT-M3-4	10
M5	1.6	3	153352	QSMT-M5-3	10
	2.2	4	153354	QSMT-M5-4	10
	2.1	6	153356	QSMT-M5-6	10
R thread					
R $\frac{1}{8}$	2.4	4	153355	QSMT- $\frac{1}{8}$ -4	10
	3.3	6	153357	QSMT- $\frac{1}{8}$ -6	10
G thread with sealing ring					
G $\frac{1}{8}$	2.4	4	186272	QSMT-G $\frac{1}{8}$ -4	10
	3.3	6	186273	QSMT-G $\frac{1}{8}$ -6	10

Push-in T-connector QSMT



Tubing O.D. D1	Nominal size [mm]	Tubing O.D. D2	Part No.	Type	PU ¹⁾
2	0.9	2	133034	QSMT-2	10
3	1.6	3	153365	QSMT-3	10
4	2.4	4	153366	QSMT-4	10
6	3.4	6	153367	QSMT-6	10
Reducing					
4	1.7	3	153368	QSMT-4-3	10
6	2.6	4	153369	QSMT-6-4	10

Push-in T-fitting QSMTL

Rotatable 360°, male thread with external hex

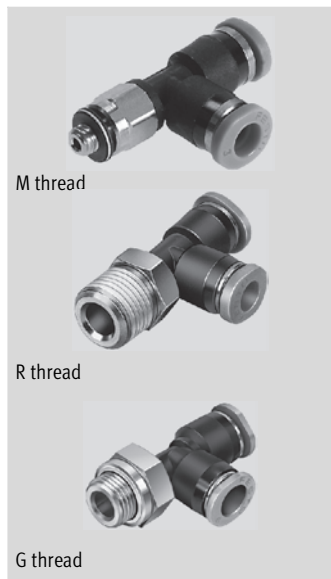

Connection D1	Nominal size [mm]	Tubing O.D. D2	Part No.	Type	PU ¹⁾
Metric thread with sealing ring					
M3	0.9	3	153358	QSMTL-M3-3	10
	1.1	4	153360	QSMTL-M3-4	10
M5	1.7	3	153359	QSMTL-M5-3	10
	1.6	4	153361	QSMTL-M5-4	10
	1.7	6	153363	QSMTL-M5-6	10
R thread					
R $\frac{1}{8}$	2.4	4	153362	QSMTL- $\frac{1}{8}$ -4	10
	3.3	6	153364	QSMTL- $\frac{1}{8}$ -6	10
G thread with sealing ring					
G $\frac{1}{8}$	2.4	4	186274	QSMTL-G $\frac{1}{8}$ -4	10
	3.3	6	186275	QSMTL-G $\frac{1}{8}$ -6	10

¹⁾ Packaging unit per part

13

★ Quick ordering

Push-in Y-connector QSMY



Tubing O.D. D1	Nominal size [mm]	Tubing O.D. D2	Part No.	Type	PU ¹⁾
2	0.9	2	133037	QSMY-2	10
3	1.6	3	153370	QSMY-3	10
4	1.7	4	153371	QSMY-4	10
6	2.9	6	153372	QSMY-6	10
2 reducing outlets					
4	1.6	3	153373	QSMY-4-3	10
6	2.8	4	153374	QSMY-6-4	10

1) Packaging unit per part

Push-in fittings QS, Quick Star

★ Quick ordering

Push-in fitting QS

Male thread with external hex



Connection D1	Nominal size [mm]	Tubing O.D. D2	Part No.	Type	PU ¹⁾
R thread					
R $\frac{1}{8}$	2.6	4	153001	QS- $\frac{1}{8}$ -4	10
	4	6	153002	QS- $\frac{1}{8}$ -6	10
	5	8	153004	QS- $\frac{1}{8}$ -8	10
	5.4	10	190643	QS- $\frac{1}{8}$ -10	10
R $\frac{1}{4}$	2.6	4	190644	QS- $\frac{1}{4}$ -4	10
	4	6	153003	QS- $\frac{1}{4}$ -6	10
	5	8	153005	QS- $\frac{1}{4}$ -8	10
	6.7	10	153007	QS- $\frac{1}{4}$ -10	10
	8.7	12	164980	QS- $\frac{1}{4}$ -12	10
R $\frac{3}{8}$	4	6	190645	QS- $\frac{3}{8}$ -6	10
	5	8	153006	QS- $\frac{3}{8}$ -8	10
	6.7	10	153008	QS- $\frac{3}{8}$ -10	10
	8.7	12	153009	QS- $\frac{3}{8}$ -12	10
	10.3	16	164957	QS- $\frac{3}{8}$ -16	1
R $\frac{1}{2}$	6.7	10	190646	QS- $\frac{1}{2}$ -10	1
	8.7	12	153010	QS- $\frac{1}{2}$ -12	1
	12	16	153011	QS- $\frac{1}{2}$ -16	1
G thread with sealing ring					
G $\frac{1}{8}$	2.6	4	186095	QS-G $\frac{1}{8}$ -4	10
	4	6	186096	QS-G $\frac{1}{8}$ -6	10
	5	8	186098	QS-G $\frac{1}{8}$ -8	10
G $\frac{1}{4}$	4	6	186097	QS-G $\frac{1}{4}$ -6	10
	5	8	186099	QS-G $\frac{1}{4}$ -8	10
	6.7	10	186101	QS-G $\frac{1}{4}$ -10	10
	6.3	12	186350	QS-G $\frac{1}{4}$ -12	10
G $\frac{3}{8}$	5	8	186100	QS-G $\frac{3}{8}$ -8	10
	6.7	10	186102	QS-G $\frac{3}{8}$ -10	10
	8.7	12	186103	QS-G $\frac{3}{8}$ -12	10
	10.3	16	186347	QS-G $\frac{3}{8}$ -16	1
G $\frac{1}{2}$	8.7	12	186104	QS-G $\frac{1}{2}$ -12	1
	12	16	186105	QS-G $\frac{1}{2}$ -16	1

¹⁾ Packaging unit per part

★ Quick ordering

Push-in fitting QS-...-I

Male thread with internal hex



Connection D1	Nominal size [mm]	Tubing O.D. D2	Part No.	Type	PU ¹⁾
R thread					
R $\frac{1}{8}$	2.1	4	153012	QS- $\frac{1}{8}$ -4-I	10
	3.7	6	153013	QS- $\frac{1}{8}$ -6-I	10
	4.7	8	153015	QS- $\frac{1}{8}$ -8-I	10
	4.9	10	190647	QS- $\frac{1}{8}$ -10-I	10
R $\frac{1}{4}$	3.7	6	153014	QS- $\frac{1}{4}$ -6-I	10
	5	8	153016	QS- $\frac{1}{4}$ -8-I	10
	5	10	153018	QS- $\frac{1}{4}$ -10-I	10
	5.7	12	190649	QS- $\frac{1}{4}$ -12-I	10
R $\frac{3}{8}$	5	8	153017	QS- $\frac{3}{8}$ -8-I	10
	5	10	153019	QS- $\frac{3}{8}$ -10-I	10
	7.1	12	153020	QS- $\frac{3}{8}$ -12-I	10
R $\frac{1}{2}$	5	10	190648	QS- $\frac{1}{2}$ -10-I	1
	7.1	12	153021	QS- $\frac{1}{2}$ -12-I	1
G thread with sealing ring					
G $\frac{1}{8}$	2.1	4	186106	QS-G $\frac{1}{8}$ -4-I	10
	3.7	6	186107	QS-G $\frac{1}{8}$ -6-I	10
	4.7	8	186109	QS-G $\frac{1}{8}$ -8-I	10
	4.9	10	132999	QS-G $\frac{1}{8}$ -10-I	10
G $\frac{1}{4}$	3.7	6	186108	QS-G $\frac{1}{4}$ -6-I	10
	5	8	186110	QS-G $\frac{1}{4}$ -8-I	10
	6.7	10	186112	QS-G $\frac{1}{4}$ -10-I	10
G $\frac{3}{8}$	5	8	186111	QS-G $\frac{3}{8}$ -8-I	10
	6.7	10	186113	QS-G $\frac{3}{8}$ -10-I	10
	7.1	12	186114	QS-G $\frac{3}{8}$ -12-I	10
G $\frac{1}{2}$	7.1	12	186115	QS-G $\frac{1}{2}$ -12-I	1

Push-in connector QS



Tubing O.D. D1	Nominal size [mm]	Tubing O.D. D2	Part No.	Type	PU ¹⁾
4	2.6	4	153031	QS-4	10
6	4	6	153032	QS-6	10
8	5	8	153033	QS-8	10
10	6.7	10	153034	QS-10	10
12	8.7	12	153035	QS-12	10
16	13.7	16	153036	QS-16	1
Reducing					
6	2.6	4	153037	QS-6-4	10
8	2.3	4	130606	QS-8-4	10
	4	6	153038	QS-8-6	10
10	3.7	6	130607	QS-10-6	10
	5	8	153039	QS-10-8	10
12	5.2	8	130608	QS-12-8	10
	6.7	10	153040	QS-12-10	10

1) Packaging unit per part

Push-in fittings QS, Quick Star

★ Quick ordering

Push-in connector QS-...H

with push-in sleeve



Push-in sleeve Ø D1	Nominal size [mm]	Tubing O.D. D2	Part No.	Type	PU ¹⁾
6	2.5	4	153041	QS-6H-4	10
8	2.4	4	130622	QS-8H-4	10
	3.8	6	153042	QS-8H-6	10
10	3.8	6	130623	QS-10H-6	10
	5.4	8	153043	QS-10H-8	10
12	3.8	6	132981	QS-12H-6	10
	5.4	8	130624	QS-12H-8	10
	6.3	10	153044	QS-12H-10	10

Push-in bulkhead connector QSS



With fixed collar

Tubing O.D. D1	Nominal size [mm]	Part No.	Type	PU ¹⁾
4	2.6	153157	QSS-4	10
6	4	153158	QSS-6	10
8	5	153159	QSS-8	10
10	6.7	153160	QSS-10	10
12	9.5	153161	QSS-12	10
With fixed collar				
8	5.5	130642	QSS-8-F	10
10	6.5	130643	QSS-10-F	10
12	7.5	130644	QSS-12-F	10

Push-in fitting QSF

Female thread with external hex



Connection D1	Nominal size [mm]	Tubing O.D. D2	Part No.	Type	PU ¹⁾
G thread with sealing ring					
G ¹ / ₈	2.6	4	153022	QSF- ¹ / ₈ -4-B	10
	4	6	153023	QSF- ¹ / ₈ -6-B	10
	5.8	8	153025	QSF- ¹ / ₈ -8-B	10
G ¹ / ₄	2.8	4	190650	QSF- ¹ / ₄ -4-B	10
	4	6	153024	QSF- ¹ / ₄ -6-B	10
	5.8	8	153026	QSF- ¹ / ₄ -8-B	10
	7.4	10	153028	QSF- ¹ / ₄ -10-B	10
	7.2	12	190651	QSF- ¹ / ₄ -12-B	10
G ³ / ₈	4.1	6	190652	QSF- ³ / ₈ -6-B	10
	5.8	8	153027	QSF- ³ / ₈ -8-B	10
	7.4	10	153029	QSF- ³ / ₈ -10-B	10
	9.5	12	153030	QSF- ³ / ₈ -12-B	10
G ¹ / ₂	9.5	12	190653	QSF- ¹ / ₂ -12-B	1
	10.6	16	190654	QSF- ¹ / ₂ -16-B	1

¹⁾ Packaging unit per part

★ Quick ordering

Push-in L-fitting QSL

Rotatable 360°, male thread with external hex



R thread

G thread

Connection D1	Nominal size [mm]	Tubing O.D. D2	Part No.	Type	PU ¹⁾
R thread					
R $\frac{1}{8}$	2.3	4	153045	QSL- $\frac{1}{8}$ -4	10
	3.6	6	153046	QSL- $\frac{1}{8}$ -6	10
	4.6	8	153048	QSL- $\frac{1}{8}$ -8	10
	5.3	10	190658	QSL- $\frac{1}{8}$ -10	10
R $\frac{1}{4}$	2.3	4	190659	QSL- $\frac{1}{4}$ -4	10
	3.6	6	153047	QSL- $\frac{1}{4}$ -6	10
	4.6	8	153049	QSL- $\frac{1}{4}$ -8	10
	6.2	10	153051	QSL- $\frac{1}{4}$ -10	10
	7.7	12	164981	QSL- $\frac{1}{4}$ -12	10
R $\frac{3}{8}$	3.6	6	190660	QSL- $\frac{3}{8}$ -6	10
	4.6	8	153050	QSL- $\frac{3}{8}$ -8	10
	6.2	10	153052	QSL- $\frac{3}{8}$ -10	10
	7.7	12	153053	QSL- $\frac{3}{8}$ -12	10
R $\frac{1}{2}$	10.1	16	164958	QSL- $\frac{3}{8}$ -16	1
	6.2	10	190661	QSL- $\frac{1}{2}$ -10	1
	7.7	12	153054	QSL- $\frac{1}{2}$ -12	1
	10.9	16	153055	QSL- $\frac{1}{2}$ -16	1
G thread with sealing ring					
G $\frac{1}{8}$	2.3	4	186116	QSL-G $\frac{1}{8}$ -4	10
	3.6	6	186117	QSL-G $\frac{1}{8}$ -6	10
	4.6	8	186119	QSL-G $\frac{1}{8}$ -8	10
G $\frac{1}{4}$	3.6	6	186118	QSL-G $\frac{1}{4}$ -6	10
	4.6	8	186120	QSL-G $\frac{1}{4}$ -8	10
	6.2	10	186122	QSL-G $\frac{1}{4}$ -10	10
	6.2	12	186351	QSL-G $\frac{1}{4}$ -12	10
G $\frac{3}{8}$	4.6	8	186121	QSL-G $\frac{3}{8}$ -8	10
	6.2	10	186123	QSL-G $\frac{3}{8}$ -10	10
	7.7	12	186124	QSL-G $\frac{3}{8}$ -12	10
	10.1	16	186348	QSL-G $\frac{3}{8}$ -16	1
G $\frac{1}{2}$	7.7	12	186125	QSL-G $\frac{1}{2}$ -12	1
	10.9	16	186126	QSL-G $\frac{1}{2}$ -16	1

1) Packaging unit per part

Push-in fittings QS, Quick Star

★ Quick ordering

Push-in long L-fitting QSLL

Rotatable 360°, male thread with external hex



Connection D1	Nominal size [mm]	Tubing O.D. D2	Part No.	Type	PU ¹⁾
R thread					
R $\frac{1}{8}$	2.3	4	153076	QSLL- $\frac{1}{8}$ -4	10
	3.6	6	153077	QSLL- $\frac{1}{8}$ -6	10
	4.6	8	153079	QSLL- $\frac{1}{8}$ -8	10
R $\frac{1}{4}$	2.9	4	190662	QSLL- $\frac{1}{4}$ -4	10
	3.6	6	153078	QSLL- $\frac{1}{4}$ -6	10
	4.6	8	153080	QSLL- $\frac{1}{4}$ -8	10
	6.2	10	153082	QSLL- $\frac{1}{4}$ -10	10
R $\frac{3}{8}$	3.5	6	190663	QSLL- $\frac{3}{8}$ -6	10
	4.8	8	153081	QSLL- $\frac{3}{8}$ -8	10
	6.2	10	153083	QSLL- $\frac{3}{8}$ -10	10
	7.5	12	153084	QSLL- $\frac{3}{8}$ -12	10
R $\frac{1}{2}$	6.4	10	190664	QSLL- $\frac{1}{2}$ -10	1
	8.3	12	153085	QSLL- $\frac{1}{2}$ -12	1
G thread with sealing ring					
G $\frac{1}{8}$	2.3	4	186127	QSLL-G $\frac{1}{8}$ -4	10
	3.6	6	186128	QSLL-G $\frac{1}{8}$ -6	10
	4.6	8	186130	QSLL-G $\frac{1}{8}$ -8	10
G $\frac{1}{4}$	3.6	6	186129	QSLL-G $\frac{1}{4}$ -6	10
	4.6	8	186131	QSLL-G $\frac{1}{4}$ -8	10
	6.2	10	186133	QSLL-G $\frac{1}{4}$ -10	10
	8	12	132596	QSLL-G $\frac{1}{4}$ -12	10
G $\frac{3}{8}$	4.8	8	186132	QSLL-G $\frac{3}{8}$ -8	10
	6.2	10	186134	QSLL-G $\frac{3}{8}$ -10	10
	7.5	12	186135	QSLL-G $\frac{3}{8}$ -12	10
G $\frac{1}{2}$	8.3	12	186136	QSLL-G $\frac{1}{2}$ -12	1
	10	16	190665	QSLL-G $\frac{1}{2}$ -16	1

¹⁾ Packaging unit per part

★ Quick ordering

Push-in L-connector QSL



Tubing O.D. D1	Nominal size [mm]	Part No.	Type	PU ¹⁾
4	2.3	153070	QSL-4	10
6	3.6	153071	QSL-6	10
8	4.6	153072	QSL-8	10
10	6.2	153073	QSL-10	10
12	7.7	153074	QSL-12	10
16	10.8	153075	QSL-16	1

Push-in L-connector QSL-...H
with push-in sleeve

Long push-in sleeve

Push-in sleeve Ø D1	Nominal size [mm]	Tubing O.D. D2	Part No.	Type	PU ¹⁾
4	2	4	153056	QSL-4H	10
6	3.2	6	153057	QSL-6H	10
8	4.7	8	153058	QSL-8H	10
10	5.7	10	153059	QSL-10H	10
12	6.8	12	153060	QSL-12H	10
Reducing					
6	2.4	4	153061	QSL-6H-4	10
8	3.5	6	153062	QSL-8H-6	10
10	4.9	8	153063	QSL-10H-8	10
12	6.1	10	153064	QSL-12H-10	10
Long push-in sleeve					
4	2	4	153065	QSL-4HL	10
6	3.1	6	153066	QSL-6HL	10
8	4.5	8	153067	QSL-8HL	10
10	5.6	10	153068	QSL-10HL	10
12	6.7	12	153069	QSL-12HL	10

Push-in L-fitting QSLF

Female thread with external hex



Connection D1	Nominal size [mm]	Tubing O.D. D2	Part No.	Type	PU ¹⁾
G thread with sealing ring					
G ¹ / ₈	2.1	4	153273	QSLF- ¹ / ₈ -4-B	10
	3.6	6	153274	QSLF- ¹ / ₈ -6-B	10
	4.7	8	153276	QSLF- ¹ / ₈ -8-B	10
G ¹ / ₄	3.6	6	153275	QSLF- ¹ / ₄ -6-B	10
	4.7	8	153277	QSLF- ¹ / ₄ -8-B	10
	5.4	10	153279	QSLF- ¹ / ₄ -10-B	10
G ³ / ₈	4.8	8	153278	QSLF- ³ / ₈ -8-B	10
	6.2	10	153280	QSLF- ³ / ₈ -10-B	10

1) Packaging unit per part

Push-in fittings QS, Quick Star

★ Quick ordering

Push-in L-fitting QSLV

Rotatable 360°, male thread with external hex



Connection D1	Nominal size [mm]	Tubing O.D. D2	Part No.	Type	PU ¹⁾
Metric thread					
M5	1.6	6	190666	QSLV-M5-6	10
R thread					
R $\frac{1}{8}$	2.4	4	153086	QSLV- $\frac{1}{8}$ -4	10
	3.7	6	153087	QSLV- $\frac{1}{8}$ -6	10
	4.4	8	153089	QSLV- $\frac{1}{8}$ -8	10
R $\frac{1}{4}$	3.8	6	153088	QSLV- $\frac{1}{4}$ -6	10
	5	8	153090	QSLV- $\frac{1}{4}$ -8	10
	5.4	10	153092	QSLV- $\frac{1}{4}$ -10	10
R $\frac{3}{8}$	5.2	8	153091	QSLV- $\frac{3}{8}$ -8	10
	6.3	10	153093	QSLV- $\frac{3}{8}$ -10	10
	7.1	12	153094	QSLV- $\frac{3}{8}$ -12	10
R $\frac{1}{2}$	8	12	153095	QSLV- $\frac{1}{2}$ -12	1
	8.9	16	153096	QSLV- $\frac{1}{2}$ -16	1
G thread					
G $\frac{1}{8}$	2.3	4	186137	QSLV-G $\frac{1}{8}$ -4	10
	3.5	6	186138	QSLV-G $\frac{1}{8}$ -6	10
	4	8	186140	QSLV-G $\frac{1}{8}$ -8	10
G $\frac{1}{4}$	3.7	6	186139	QSLV-G $\frac{1}{4}$ -6	10
	4.9	8	186141	QSLV-G $\frac{1}{4}$ -8	10
	5.3	10	186143	QSLV-G $\frac{1}{4}$ -10	10
G $\frac{3}{8}$	5.4	8	186142	QSLV-G $\frac{3}{8}$ -8	10
	6.4	10	186144	QSLV-G $\frac{3}{8}$ -10	10
	6.4	12	186145	QSLV-G $\frac{3}{8}$ -12	10
G $\frac{1}{2}$	7	12	186146	QSLV-G $\frac{1}{2}$ -12	1
	8.1	16	186147	QSLV-G $\frac{1}{2}$ -16	1

Push-in L-fitting QSLV-...-I

Rotatable 360°, male thread with internal hex



Connection D1	Nominal size [mm]	Tubing O.D. D2	Part No.	Type	PU ¹⁾
R thread					
R $\frac{1}{8}$	3	6	153097	QSLV- $\frac{1}{8}$ -6-I	10
	4.2	8	153099	QSLV- $\frac{1}{8}$ -8-I	10
R $\frac{1}{4}$	3.1	6	153098	QSLV- $\frac{1}{4}$ -6-I	10
	4	8	153100	QSLV- $\frac{1}{4}$ -8-I	10
	5.4	10	153102	QSLV- $\frac{1}{4}$ -10-I	10
R $\frac{3}{8}$	4.2	8	153101	QSLV- $\frac{3}{8}$ -8-I	10
	5.4	10	153103	QSLV- $\frac{3}{8}$ -10-I	10
	6.9	12	153104	QSLV- $\frac{3}{8}$ -12-I	10
R $\frac{1}{2}$	6.4	12	153105	QSLV- $\frac{1}{2}$ -12-I	1
G thread					
G $\frac{1}{8}$	3	6	186148	QSLV-G $\frac{1}{8}$ -6-I	10
	4.2	8	186150	QSLV-G $\frac{1}{8}$ -8-I	10
G $\frac{1}{4}$	3.1	6	186149	QSLV-G $\frac{1}{4}$ -6-I	10
	4	8	186151	QSLV-G $\frac{1}{4}$ -8-I	10
	5.4	10	186153	QSLV-G $\frac{1}{4}$ -10-I	10
G $\frac{3}{8}$	4.2	8	186152	QSLV-G $\frac{3}{8}$ -8-I	10
	5.4	10	186154	QSLV-G $\frac{3}{8}$ -10-I	10
	6.9	12	186155	QSLV-G $\frac{3}{8}$ -12-I	10
G $\frac{1}{2}$	6.4	12	186156	QSLV-G $\frac{1}{2}$ -12-I	1

1) Packaging unit per part

★ Quick ordering

Push-in T-fitting QST

Rotatable 360°, male thread with external hex



Connection D1	Nominal size [mm]	Tubing O.D. D2	Part No.	Type	PU ¹⁾
R thread					
R $\frac{1}{8}$	4.1	4	153106	QST- $\frac{1}{8}$ -4	10
	4.7	6	153107	QST- $\frac{1}{8}$ -6	10
	5.4	8	153109	QST- $\frac{1}{8}$ -8	10
	5.6	10	190667	QST- $\frac{1}{8}$ -10	10
R $\frac{1}{4}$	2.3	4	190668	QST- $\frac{1}{4}$ -4	10
	5.7	6	153108	QST- $\frac{1}{4}$ -6	10
	6	8	153110	QST- $\frac{1}{4}$ -8	10
	7.3	10	153112	QST- $\frac{1}{4}$ -10	10
	6.2	12	190669	QST- $\frac{1}{4}$ -12	10
R $\frac{3}{8}$	3.6	6	190670	QST- $\frac{3}{8}$ -6	10
	7.2	8	153111	QST- $\frac{3}{8}$ -8	10
	8	10	153113	QST- $\frac{3}{8}$ -10	10
	8.8	12	153114	QST- $\frac{3}{8}$ -12	10
	10.1	16	164959	QST- $\frac{3}{8}$ -16	1
R $\frac{1}{2}$	6.2	10	190672	QST- $\frac{1}{2}$ -10	1
	9.9	12	153115	QST- $\frac{1}{2}$ -12	1
	10.8	16	153116	QST- $\frac{1}{2}$ -16	1
G thread with sealing ring					
G $\frac{1}{8}$	2.3	4	186157	QST-G $\frac{1}{8}$ -4	10
	3.6	6	186158	QST-G $\frac{1}{8}$ -6	10
	4.6	8	186160	QST-G $\frac{1}{8}$ -8	10
G $\frac{1}{4}$	3.6	6	186159	QST-G $\frac{1}{4}$ -6	10
	4.6	8	186161	QST-G $\frac{1}{4}$ -8	10
	6.2	10	186163	QST-G $\frac{1}{4}$ -10	10
	8	12	132597	QST-G $\frac{1}{4}$ -12	10
G $\frac{3}{8}$	4.6	8	186162	QST-G $\frac{3}{8}$ -8	10
	6.2	10	186164	QST-G $\frac{3}{8}$ -10	10
	7.7	12	186165	QST-G $\frac{3}{8}$ -12	10
	10.1	16	186349	QST-G $\frac{3}{8}$ -16	1
G $\frac{1}{2}$	7.7	12	186166	QST-G $\frac{1}{2}$ -12	1
	10.8	16	186167	QST-G $\frac{1}{2}$ -16	1

Push-in T-connector QST



Tubing O.D. D1	Nominal size [mm]	Tubing O.D. D2	Part No.	Type	PU ¹⁾
4	2.6	4	153128	QST-4	10
6	4	6	153129	QST-6	10
8	5	8	153130	QST-8	10
10	6.7	10	153131	QST-10	10
12	8.7	12	153132	QST-12	10
16	10.7	16	153133	QST-16	1
Reducing					
6	2.3	4	153134	QST-6-4	10
8	2.3	4	130613	QST-8-4	10
8	3.5	6	153135	QST-8-6	10
10	3.7	6	130614	QST-10-6	10
10	4.9	8	153136	QST-10-8	10
12	5.1	8	130615	QST-12-8	10
12	6.1	10	153137	QST-12-10	10
16	7.6	12	130616	QST-16-12	1

1) Packaging unit per part

Push-in fittings QS, Quick Star

★ Quick ordering

Push-in T-fitting QSTF

Rotatable 360°, with female and male thread



Connection D1	Female thread D3	Nominal size [mm]	Tubing O.D. D2	Part No.	Type	PU ¹⁾
R thread						
R $\frac{1}{8}$	G $\frac{1}{8}$	2.5	4	153182	QSTF- $\frac{1}{8}$ -4-B	1
		3.3	6	153183	QSTF- $\frac{1}{8}$ -6-B	1
		3.6	8	153185	QSTF- $\frac{1}{8}$ -8-B	1
R $\frac{1}{4}$	G $\frac{1}{4}$	3.6	6	153184	QSTF- $\frac{1}{4}$ -6-B	1
		4.4	8	153186	QSTF- $\frac{1}{4}$ -8-B	1
		4.4	10	153188	QSTF- $\frac{1}{4}$ -10-B	1
R $\frac{3}{8}$	G $\frac{3}{8}$	4.9	8	153187	QSTF- $\frac{3}{8}$ -8-B	1
		5.6	10	153189	QSTF- $\frac{3}{8}$ -10-B	1
		6	12	153190	QSTF- $\frac{3}{8}$ -12-B	1
R $\frac{1}{2}$	G $\frac{1}{2}$	7.4	12	153191	QSTF- $\frac{1}{2}$ -12-B	1
G thread with sealing ring						
G $\frac{1}{8}$	G $\frac{1}{8}$	2.4	4	186199	QSTF-G $\frac{1}{8}$ -4	1
		3.2	6	186200	QSTF-G $\frac{1}{8}$ -6	1
		3.7	8	186202	QSTF-G $\frac{1}{8}$ -8	1
G $\frac{1}{4}$	G $\frac{1}{4}$	3.7	6	186201	QSTF-G $\frac{1}{4}$ -6	1
		4.4	8	186203	QSTF-G $\frac{1}{4}$ -8	1
		4.9	10	186205	QSTF-G $\frac{1}{4}$ -10	1
G $\frac{3}{8}$	G $\frac{3}{8}$	4.9	8	186204	QSTF-G $\frac{3}{8}$ -8	1
		5.8	10	186206	QSTF-G $\frac{3}{8}$ -10	1
		6	12	186207	QSTF-G $\frac{3}{8}$ -12	1
G $\frac{1}{2}$	G $\frac{1}{2}$	7	12	186208	QSTF-G $\frac{1}{2}$ -12	1

Push-in T-fitting QSTL

Rotatable 360°, male thread with external hex



Connection D1	Nominal size [mm]	Tubing O.D. D2	Part No.	Type	PU ¹⁾
R thread					
R $\frac{1}{8}$	2.6	4	153117	QSTL- $\frac{1}{8}$ -4	10
	4	6	153118	QSTL- $\frac{1}{8}$ -6	10
	5	8	153120	QSTL- $\frac{1}{8}$ -8	10
R $\frac{1}{4}$	4	6	153119	QSTL- $\frac{1}{4}$ -6	10
	5	8	153121	QSTL- $\frac{1}{4}$ -8	10
	6.7	10	153123	QSTL- $\frac{1}{4}$ -10	10
R $\frac{3}{8}$	5	8	153122	QSTL- $\frac{3}{8}$ -8	10
	6.7	10	153124	QSTL- $\frac{3}{8}$ -10	10
	8.7	12	153125	QSTL- $\frac{3}{8}$ -12	10
R $\frac{1}{2}$	8.7	12	153126	QSTL- $\frac{1}{2}$ -12	1
	10.9	16	153127	QSTL- $\frac{1}{2}$ -16	1
G thread with sealing ring					
G $\frac{1}{8}$	2.6	4	186168	QSTL-G $\frac{1}{8}$ -4	10
	4	6	186169	QSTL-G $\frac{1}{8}$ -6	10
	5	8	186171	QSTL-G $\frac{1}{8}$ -8	10
G $\frac{1}{4}$	4	6	186170	QSTL-G $\frac{1}{4}$ -6	10
	5	8	186172	QSTL-G $\frac{1}{4}$ -8	10
	6.7	10	186174	QSTL-G $\frac{1}{4}$ -10	10
G $\frac{3}{8}$	5	8	186173	QSTL-G $\frac{3}{8}$ -8	10
	6.7	10	186175	QSTL-G $\frac{3}{8}$ -10	10
	8.7	12	186176	QSTL-G $\frac{3}{8}$ -12	10
G $\frac{1}{2}$	8.7	12	186177	QSTL-G $\frac{1}{2}$ -12	1
	10.9	16	187178	QSTL-G $\frac{1}{2}$ -16	1

¹⁾ Packaging unit per part

★ Quick ordering

Push-in fitting QSW

360° rotatable, male thread



Connection D1	Nominal size [mm]	Tubing O.D. D2	Part No.	Type	PU ¹⁾
R thread					
R $\frac{1}{8}$	2.5	4	130596	QSW- $\frac{1}{8}$ -4	10
	3.3	6	130597	QSW- $\frac{1}{8}$ -6	10
	5.3	8	130598	QSW- $\frac{1}{8}$ -8	10
R $\frac{1}{4}$	3.3	6	130599	QSW- $\frac{1}{4}$ -6	10
	5.3	8	130600	QSW- $\frac{1}{4}$ -8	10
	7	10	130601	QSW- $\frac{1}{4}$ -10	10
R $\frac{3}{8}$	7	10	130602	QSW- $\frac{3}{8}$ -10	10
	7.5	12	130603	QSW- $\frac{3}{8}$ -12	10
R $\frac{1}{2}$	7.5	12	130604	QSW- $\frac{1}{2}$ -12	1
	10.7	16	130605	QSW- $\frac{1}{2}$ -16	1

Push-in connector QSW...HL

with push-in sleeve



Push-in sleeve \varnothing D1	Nominal size [mm]	Tubing O.D. D2	Part No.	Type	PU ¹⁾
4	2	4	130617	QSW-4HL	10
6	2.7	6	130618	QSW-6HL	10
8	5	8	130619	QSW-8HL	10
10	6.3	10	130620	QSW-10HL	10
12	6.9	12	130621	QSW-12HL	10

1) Packaging unit per part

Push-in fittings QS, Quick Star

FESTO

★ Quick ordering

Push-in Y-fitting QSY

Rotatable 360°, male thread with external hex



Connection D1	Nominal size [mm]	Tubing O.D. D2	Part No.	Type	PU ¹⁾
Metric thread with sealing ring					
M5	1.4	4	190673	QSY-M5-4	10
	1.4	6	190674	QSY-M5-6	10
R thread					
R $\frac{1}{8}$	2.3	4	153138	QSY- $\frac{1}{8}$ -4	10
	3.6	6	153139	QSY- $\frac{1}{8}$ -6	10
	4.6	8	153141	QSY- $\frac{1}{8}$ -8	10
R $\frac{1}{4}$	2.3	4	190675	QSY- $\frac{1}{4}$ -4	10
	3.6	6	153140	QSY- $\frac{1}{4}$ -6	10
	4.6	8	153142	QSY- $\frac{1}{4}$ -8	10
	6.2	10	153144	QSY- $\frac{1}{4}$ -10	10
R $\frac{3}{8}$	4.6	8	153143	QSY- $\frac{3}{8}$ -8	10
	6.2	10	153145	QSY- $\frac{3}{8}$ -10	10
	6.9	12	153146	QSY- $\frac{3}{8}$ -12	10
R $\frac{1}{2}$	6.9	12	153147	QSY- $\frac{1}{2}$ -12	1
G thread with sealing ring					
G $\frac{1}{8}$	2.3	4	186179	QSY-G $\frac{1}{8}$ -4	10
	3.6	6	186180	QSY-G $\frac{1}{8}$ -6	10
	4.6	8	186182	QSY-G $\frac{1}{8}$ -8	10
G $\frac{1}{4}$	3.6	6	186181	QSY-G $\frac{1}{4}$ -6	10
	4.6	8	186183	QSY-G $\frac{1}{4}$ -8	10
	6.2	10	186185	QSY-G $\frac{1}{4}$ -10	10
G $\frac{3}{8}$	4.6	8	186184	QSY-G $\frac{3}{8}$ -8	10
	6.2	10	186186	QSY-G $\frac{3}{8}$ -10	10
	6.9	12	186187	QSY-G $\frac{3}{8}$ -12	10
G $\frac{1}{2}$	6.9	12	186188	QSY-G $\frac{1}{2}$ -12	1

Push-in Y-connector QSY



Tubing O.D. D1	Nominal size [mm]	Tubing O.D. D2	Part No.	Type	PU ¹⁾
4	2.3	4	153148	QSY-4	10
6	3.6	6	153149	QSY-6	10
8	4.6	8	153150	QSY-8	10
10	5.9	10	153151	QSY-10	10
12	7	12	153152	QSY-12	10
16	8.5	16	130609	QSY-16	1
2 reducing outlets					
6	2.3	4	153153	QSY-6-4	10
8	1.7	4	130610	QSY-8-4	10
8	3.2	6	153154	QSY-8-6	10
10	3.3	6	130611	QSY-10-6	10
10	4.5	8	153155	QSY-10-8	10
12	4.5	8	130612	QSY-12-8	10
12	5.8	10	153156	QSY-12-10	10
16	7	12	190708	QSY-16-12	1

1) Packaging unit per part

★ Quick ordering

Push-in Y-fitting QSY-...H

with push-in sleeve



Push-in sleeve Ø D1	Nominal size [mm]	Tubing O.D. D2	Part No.	Type	PU ¹⁾
4	1.6	4	130628	QSY-4H	10
6	3.1	6	133145	QSY-6H-B	10
8	4.6	8	133146	QSY-8H-B	10
10	5.9	10	133148	QSY-10H-B	10
12	7.3	12	133150	QSY-12H-B	10
Reducing					
6	2.3	4	130633	QSY-6H-4	10
8	3.6	6	133147	QSY-8H-6-B	10
10	4.6	8	133149	QSY-10H-8-B	10
12	5.9	10	133151	QSY-12H-10-B	10

Push-in Y-fitting QSYL

Rotatable 360°, male thread with external hex



R thread

G thread

Connection D1	Nominal size [mm]	Tubing O.D. D2	Part No.	Type	PU ¹⁾
R thread					
R ¹ / ₈	1.9	4	153172	QSYL- ¹ / ₈ -4	1
	3	6	153173	QSYL- ¹ / ₈ -6	1
	4.3	8	153175	QSYL- ¹ / ₈ -8	1
R ¹ / ₄	2.9	6	153174	QSYL- ¹ / ₄ -6	1
	4.3	8	153176	QSYL- ¹ / ₄ -8	1
	5.8	10	153178	QSYL- ¹ / ₄ -10	1
R ³ / ₈	4.4	8	153177	QSYL- ³ / ₈ -8	1
	5.9	10	153179	QSYL- ³ / ₈ -10	1
	7.4	12	153180	QSYL- ³ / ₈ -12	1
R ¹ / ₂	7.3	12	153181	QSYL- ¹ / ₂ -12	1
G thread with sealing ring					
G ¹ / ₈	1.9	4	186189	QSYL-G ¹ / ₈ -4	1
	3	6	186190	QSYL-G ¹ / ₈ -6	1
	4.3	8	186192	QSYL-G ¹ / ₈ -8	1
G ¹ / ₄	2.9	6	186191	QSYL-G ¹ / ₄ -6	1
	4.3	8	186193	QSYL-G ¹ / ₄ -8	1
	5.8	10	186195	QSYL-G ¹ / ₄ -10	1
G ³ / ₈	4.4	8	186194	QSYL-G ³ / ₈ -8	1
	5.9	10	186196	QSYL-G ³ / ₈ -10	1
	7.4	12	186197	QSYL-G ³ / ₈ -12	1
G ¹ / ₂	7.3	12	186198	QSYL-G ¹ / ₂ -12	1

Push-in Y-fitting QSYLV

Rotatable 360°, male thread with external hex



R thread

G thread

Connection D1	Nominal size [mm]	Tubing O.D. D2	Part No.	Type	PU ¹⁾
R thread					
R ¹ / ₈	3.3	6	153192	QSYLV- ¹ / ₈ -6	1
R ¹ / ₄	4.4	8	153193	QSYLV- ¹ / ₄ -8	1
R ³ / ₈	5.7	10	153194	QSYLV- ³ / ₈ -10	1
R ¹ / ₂	7.1	12	153195	QSYLV- ¹ / ₂ -12	1
G thread with sealing ring					
G ¹ / ₈	3.5	6	186209	QSYLV-G ¹ / ₈ -6	1
G ¹ / ₄	4.7	8	186210	QSYLV-G ¹ / ₄ -8	1
G ³ / ₈	5.2	10	186211	QSYLV-G ³ / ₈ -10	1
G ¹ / ₂	7	12	186212	QSYLV-G ¹ / ₂ -12	1

1) Packaging unit per part

Push-in fittings NPQP

FESTO



- Low-cost alternative to stainless steel: resistant to most cleaning agents in combination with tubing PLN
- Housing made from polypropylene
- Male thread with external hex
- Push-in bulkhead connector

www.festo.com/catalogue/npqp

Product range overview

Type	Version	Design	Connection D1			Connection D2		→ Page/ online
			R thread	Tubing O.D.	Push-in sleeve Ø	Tubing O.D.	Push-in sleeve Ø	
NPQP-D	Push-in fitting	Straight	■	-	-	■	-	929
	Push-in connector		-	■	-	■	■	
NPQP-H	Push-in bulkhead connector		-	■	-	-	-	
NPQP-P	Blanking plug		-	-	■	-	-	
NPQP-L	Push-in fitting	L-shape	■	-	-	■	-	930
	Push-in connector		-	■	-	■	-	
NPQP-T	Push-in fitting	T-shape	■	-	-	■	-	931
	Push-in connector		-	■	-	■	-	
NPQP-Y	Push-in fitting	Y-shape	■	-	-	■	-	
	Push-in connector		-	■	-	■	-	

Technical data

Operating conditions	
Operating medium	Compressed air to ISO 8573-1:2010 [7:--:-]
Note on operating/pilot medium	Lubricated operation possible
Temperature-dependent operating pressure [bar]	-0.95 ... +10
Ambient temperature [°C]	-20 ... +60 Extended temperature range on request
Suitable for use in the food industry	As per manufacturer's declaration

Materials	
Housing	PP
Tube retaining claw	High-alloy stainless steel

Note

Leaks can occur with large temperature fluctuations due to the high expansion coefficient of polypropylene in combination with the R thread. To avoid this it is recommended to seal the thread with Loctite®55 thread sealing cord.

Ordering data

Push-in fitting NPQP-D

Male thread with external hex



Connection D1	Nominal size [mm]	Tubing O.D. D2	Part No.	Type	PU ¹⁾
R $\frac{1}{8}$	2.1	4	133041	NPQP-D-R18-Q4-FD-P10	10
	3.4	6	133043	NPQP-D-R18-Q6-FD-P10	10
	5.3	8	133045	NPQP-D-R18-Q8-FD-P10	10
R $\frac{1}{4}$	2.1	4	133042	NPQP-D-R14-Q4-FD-P10	10
	3.4	6	133044	NPQP-D-R14-Q6-FD-P10	10
	5.3	8	133046	NPQP-D-R14-Q8-FD-P10	10
	6.2	10	133047	NPQP-D-R14-Q10-FD-P10	10
R $\frac{3}{8}$	6.2	10	133048	NPQP-D-R38-Q10-FD-P10	10
	7.2	12	133049	NPQP-D-R38-Q12-FD-P10	10
R $\frac{1}{2}$	7.2	12	133050	NPQP-D-R12-Q12-FD	1

Push-in connector NPQD-D



Tubing O.D. D1	Nominal size [mm]	Tubing O.D. D2	Part No.	Type	PU ¹⁾
4	2.6	4	133091	NPQP-D-Q4-E-FD-P10	10
6	4	6	133092	NPQP-D-Q6-E-FD-P10	10
8	5	8	133093	NPQP-D-Q8-E-FD-P10	10
10	6.7	10	133094	NPQP-D-Q10-E-FD-P10	10
12	8.7	12	133095	NPQP-D-Q12-E-FD-P10	10
Reducing					
6	2.6	4	133096	NPQP-D-Q6-Q4-FD-P10	10
8	4	6	133097	NPQP-D-Q8-Q6-FD-P10	10
10	5	8	133098	NPQP-D-Q10-Q8-FD-P10	10
12	6.7	10	133099	NPQP-D-Q12-Q10-FD-P10	10

Push-in connector NPQP-D

with push-in sleeve



Tubing O.D. D1	Nominal size [mm]	Push-in sleeve Ø D2	Part No.	Type	PU ¹⁾
4	2.5	6	133133	NPQP-D-Q4-S6-FD-P10	10
	2.4	8	133134	NPQP-D-Q4-S8-FD-P10	10
6	3.8	8	133135	NPQP-D-Q6-S8-FD-P10	10
	3.8	10	133136	NPQP-D-Q6-S10-FD-P10	10
8	5.4	10	133137	NPQP-D-Q8-S10-FD-P10	10
	5.4	12	133138	NPQP-D-Q8-S12-FD-P10	10
10	6.3	12	133139	NPQP-D-Q10-S12-FD-P10	10

Push-in bulkhead connector NPQP-H



Tubing O.D. D1	Nominal size [mm]	Part No.	Type	PU ¹⁾
4	2.3	133100	NPQP-H-Q4-E-FD	1
6	3.7	133101	NPQP-H-Q6-E-FD	1
8	4.9	133102	NPQP-H-Q8-E-FD	1
10	7.1	133103	NPQP-H-Q10-E-FD	1
12	7.8	133104	NPQP-H-Q12-E-FD	1

¹⁾ Packaging unit per part

Push-in fittings NPQP

FESTO

Ordering data

Blanking plug NPQP-P



Push-in sleeve Ø D1	Part No.	Type	PU ¹⁾
4	133128	NPQP-P-S4-FD-P10	10
6	133129	NPQP-P-S6-FD-P10	10
8	133130	NPQP-P-S8-FD-P10	10
10	133131	NPQP-P-S10-FD-P10	10
12	133132	NPQP-P-S12-FD-P10	10

Push-in L-fitting NPQP-L

Male thread with external hex



Connection D1	Nominal size [mm]	Tubing O.D. D2	Part No.	Type	PU ¹⁾
R ³ / ₈	2.1	4	133051	NPQP-L-R18-Q4-FD-P10	10
	3.3	6	133053	NPQP-L-R18-Q6-FD-P10	10
	4.7	8	133055	NPQP-L-R18-Q8-FD-P10	10
R ¹ / ₄	2.1	4	133052	NPQP-L-R14-Q4-FD-P10	10
	3.3	6	133054	NPQP-L-R14-Q6-FD-P10	10
	4.7	8	133056	NPQP-L-R14-Q8-FD-P10	10
	5.7	10	133057	NPQP-L-R14-Q10-FD-P10	10
R ³ / ₈	5.7	10	133058	NPQP-L-R38-Q10-FD-P10	10
	6.9	12	133059	NPQP-L-R38-Q12-FD-P10	10
R ¹ / ₂	6.9	12	133060	NPQP-L-R12-Q12-FD	1

Push-in L-fitting NPQP-LQ

Male thread with external hex



Connection D1	Nominal size [mm]	Tubing O.D. D2	Part No.	Type	PU ¹⁾
R ³ / ₈	2	4	133061	NPQP-LQ-R18-Q4-FD-P10	10
	3.3	6	133063	NPQP-LQ-R18-Q6-FD-P10	10
	4.8	8	133065	NPQP-LQ-R18-Q8-FD-P10	10
R ¹ / ₄	2	4	133062	NPQP-LQ-R14-Q4-FD-P10	10
	3.3	6	133064	NPQP-LQ-R14-Q6-FD-P10	10
	4.8	8	133066	NPQP-LQ-R14-Q8-FD-P10	10
	5.8	10	133067	NPQP-LQ-R14-Q10-FD-P10	10
R ³ / ₈	5.8	10	133068	NPQP-LQ-R38-Q10-FD-P10	10
	6.9	12	133069	NPQP-LQ-R38-Q12-FD-P10	10
R ¹ / ₂	6.9	12	133070	NPQP-LQ-R12-Q12-FD	1

Push-in L-connector NPQP-L



Tubing O.D. D1	Nominal size [mm]	Tubing O.D. D1	Part No.	Type	PU ¹⁾
4	2.3	4	133105	NPQP-L-Q4-E-FD-P10	10
6	3.6	6	133106	NPQP-L-Q6-E-FD-P10	10
8	4.6	8	133107	NPQP-L-Q8-E-FD-P10	10
10	6.2	10	133108	NPQP-L-Q10-E-FD-P10	10
12	7.7	12	133109	NPQP-L-Q12-E-FD-P10	10

¹⁾ Packaging unit per part

Ordering data

Push-in T-fitting NPQP-T

Male thread with external hex



Connection D1	Nominal size [mm]	Tubing O.D. D2	Part No.	Type	PU ¹⁾
R ¹ / ₈	2	4	133071	NPQP-T-R18-Q4-FD-P10	10
	3.2	6	133073	NPQP-T-R18-Q6-FD-P10	10
	4.7	8	133075	NPQP-T-R18-Q8-FD-P10	10
R ¹ / ₄	2	4	133072	NPQP-T-R14-Q4-FD-P10	10
	3.2	6	133074	NPQP-T-R14-Q6-FD-P10	10
	4.7	8	133076	NPQP-T-R14-Q8-FD-P10	10
	5.8	10	133077	NPQP-T-R14-Q10-FD-P10	10
R ³ / ₈	5.8	10	133078	NPQP-T-R38-Q10-FD-P10	10
	6.9	12	133079	NPQP-T-R38-Q12-FD-P10	10
R ¹ / ₂	6.9	12	133080	NPQP-T-R12-Q12-FD	1

Push-in T-connector NPQP-T



Tubing O.D. D1	Nominal size [mm]	Tubing O.D. D2	Part No.	Type	PU ¹⁾
4	2.6	4	133110	NPQP-T-Q4-E-FD-P10	10
6	4	6	133111	NPQP-T-Q6-E-FD-P10	10
8	5	8	133112	NPQP-T-Q8-E-FD-P10	10
10	6.7	10	133113	NPQP-T-Q10-E-FD-P10	10
12	8.7	12	133114	NPQP-T-Q12-E-FD-P10	10
Reducing					
6	2.3	4	133115	NPQP-T-Q6-Q4-FD-P10	10
8	3.6	6	133116	NPQP-T-Q8-Q6-FD-P10	10
10	5	8	133117	NPQP-T-Q10-Q8-FD-P10	10
12	6.4	10	133118	NPQP-T-Q12-Q10-FD-P10	10

Push-in Y-fitting NPQP-Y

Male thread with external hex



Connection D1	Nominal size [mm]	Tubing O.D. D2	Part No.	Type	PU ¹⁾
R ¹ / ₈	2	4	133081	NPQP-Y-R18-Q4-FD-P10	10
	2.8	6	133083	NPQP-Y-R18-Q6-FD-P10	10
	4.5	8	133085	NPQP-Y-R18-Q8-FD-P10	10
R ¹ / ₄	2	4	133082	NPQP-Y-R14-Q4-FD-P10	10
	2.8	6	133084	NPQP-Y-R14-Q6-FD-P10	10
	4.5	8	133086	NPQP-Y-R14-Q8-FD-P10	10
	5.3	10	133087	NPQP-Y-R14-Q10-FD-P10	10
R ³ / ₈	5.3	10	133088	NPQP-Y-R38-Q10-FD-P10	10
	6.2	12	133089	NPQP-Y-R38-Q12-FD-P10	10
R ¹ / ₂	6.2	12	133090	NPQP-Y-R12-Q12-FD	1

Push-in Y-connector NPQP-Y



Tubing O.D. D1	Nominal size [mm]	Tubing O.D. D2	Part No.	Type	PU ¹⁾
4	2.3	4	133119	NPQP-Y-Q4-E-FD-P10	10
6	3.6	6	133120	NPQP-Y-Q6-E-FD-P10	10
8	4.6	8	133121	NPQP-Y-Q8-E-FD-P10	10
10	5.9	10	133122	NPQP-Y-Q10-E-FD-P10	10
12	7	12	133123	NPQP-Y-Q12-E-FD-P10	10
Reducing					
6	2.3	4	133124	NPQP-Y-Q6-Q4-FD-P10	10
8	3.6	6	133125	NPQP-Y-Q8-Q6-FD-P10	10
10	4.7	8	133126	NPQP-Y-Q10-Q8-FD-P10	10
12	5.9	10	133127	NPQP-Y-Q12-Q10-FD-P10	10

¹⁾ Packaging unit per part

Multiple distributors QS, Quick Star

FESTO



- Easy to insert
- Easy to release
- Up to 6 outlets
- Rotatable 360°

→ www.festo.com/catalogue/quick_star

Key features

Rotatable 360°



Alignment is done during assembly.
Tube movement is adjusted during use.

Product range overview

Type	Version	Design	Connection D1			Connection D2	→ Page/ online
			R thread	G thread	Tubing O.D.	Tubing O.D.	
QSLV2	Multiple distributor, 2 outlets	L-shape	■	■	–	■	933
QSLV3	Multiple distributor, 3 outlets		■	■	–	■	
QSLV4	Multiple distributor, 4 outlets		■	■	–	■	934
QSLV6	Multiple distributor, 6 outlets		■	■	–	■	
QSQ	Multiple distributor, 4 outlets	Straight	■	■	■	■	935
QST3	Multiple distributor, 4 outlets	T-shape	■	■	■	■	qst3

Technical data

Operating conditions		
Operating medium		Compressed air to ISO 8573-1:2010 [7:-:-]
Note on operating/pilot medium		Lubricated operation possible
Temperature-dependent operating pressure	[bar]	-0.95 ... +14
Ambient temperature	[°C]	-10 ... +80

Materials	
Housing	PBT
Tube retaining claw	High-alloy stainless steel
Releasing ring	POM
Tubing seal	NBR

Ordering data

Multiple distributor QSLV2

2 outlets, rotatable 360°



Connection D1	Nominal size [mm]	Tubing O.D. D2	Part No.	Type	PU ¹⁾
R thread					
R ¹ / ₈	2.4	4	153211	QSLV2-1/8-4	1
	3.2	6	153212	QSLV2-1/8-6	1
	4.2	8	153214	QSLV2-1/8-8	1
R ¹ / ₄	3.2	6	153213	QSLV2-1/4-6	1
	4.3	8	153215	QSLV2-1/4-8	1
	5.2	10	153217	QSLV2-1/4-10	1
R ³ / ₈	4.3	8	153216	QSLV2-3/8-8	1
	5.3	10	153218	QSLV2-3/8-10	1
	6.3	12	153219	QSLV2-3/8-12	1
R ¹ / ₂	6.4	12	153220	QSLV2-1/2-12	1
G thread with sealing ring					
G ¹ / ₈	2.4	4	186223	QSLV2-G1/8-4	1
	3.2	6	186224	QSLV2-G1/8-6	1
	4.2	8	186226	QSLV2-G1/8-8	1
G ¹ / ₄	3.2	6	186225	QSLV2-G1/4-6	1
	4.3	8	186227	QSLV2-G1/4-8	1
	5.2	10	186229	QSLV2-G1/4-10	1
G ³ / ₈	4.3	8	186228	QSLV2-G3/8-8	1
	5.3	10	186230	QSLV2-G3/8-10	1
	6.3	12	186231	QSLV2-G3/8-12	1
G ¹ / ₂	6.4	12	186232	QSLV2-G1/2-12	1

Multiple distributor QSLV3

3 outlets, rotatable 360°

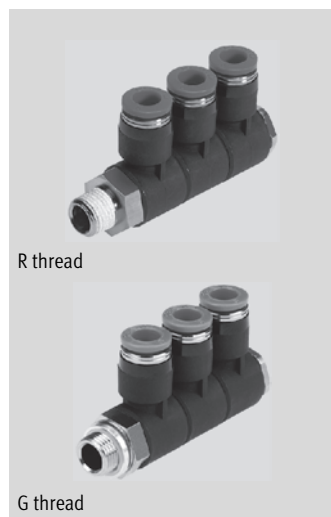

Connection D1	Nominal size [mm]	Tubing O.D. D2	Part No.	Type	PU ¹⁾
R thread					
R ¹ / ₈	2.4	4	153221	QSLV3-1/8-4	1
	3.2	6	153222	QSLV3-1/8-6	1
	4.3	8	153224	QSLV3-1/8-8	1
R ¹ / ₄	3.2	6	153223	QSLV3-1/4-6	1
	4.2	8	153225	QSLV3-1/4-8	1
	5.2	10	153227	QSLV3-1/4-10	1
R ³ / ₈	4.3	8	153226	QSLV3-3/8-8	1
	5.3	10	153228	QSLV3-3/8-10	1
	6.4	12	153229	QSLV3-3/8-12	1
R ¹ / ₂	6.5	12	153230	QSLV3-1/2-12	1
G thread with sealing ring					
G ¹ / ₈	2.4	4	186233	QSLV3-G1/8-4	1
	3.2	6	186234	QSLV3-G1/8-6	1
	4.3	8	186236	QSLV3-G1/8-8	1
G ¹ / ₄	3.2	6	186235	QSLV3-G1/4-6	1
	4.2	8	186237	QSLV3-G1/4-8	1
	5.2	10	186239	QSLV3-G1/4-10	1
G ³ / ₈	4.3	8	186238	QSLV3-G3/8-8	1
	5.3	10	186240	QSLV3-G3/8-10	1
	6.4	12	186241	QSLV3-G3/8-12	1
G ¹ / ₂	6.5	12	186242	QSLV3-G1/2-12	1

1) Packaging unit per part

Multiple distributors QSLV, Quick Star

FESTO

Ordering data

Multiple distributor QSLV4

4 outlets, rotatable 360°



Connection D1	Nominal size [mm]	Tubing O.D. D2	Part No.	Type	PU ¹⁾
R thread					
R $\frac{1}{8}$	2.3	4	153231	QSLV4- $\frac{1}{8}$ -4	1
	2.9	6	153232	QSLV4- $\frac{1}{8}$ -6	1
	4	8	153234	QSLV4- $\frac{1}{8}$ -8	1
R $\frac{1}{4}$	2.9	6	153233	QSLV4- $\frac{1}{4}$ -6	1
	4.1	8	153235	QSLV4- $\frac{1}{4}$ -8	1
	5	10	153237	QSLV4- $\frac{1}{4}$ -10	1
R $\frac{3}{8}$	4.1	8	153236	QSLV4- $\frac{3}{8}$ -8	1
	5.1	10	153238	QSLV4- $\frac{3}{8}$ -10	1
	6	12	153239	QSLV4- $\frac{3}{8}$ -12	1
R $\frac{1}{2}$	6.2	12	153240	QSLV4- $\frac{1}{2}$ -12	1
G thread with sealing ring					
G $\frac{1}{8}$	2.3	4	186243	QSLV4-G $\frac{1}{8}$ -4	1
	2.9	6	186244	QSLV4-G $\frac{1}{8}$ -6	1
	4	8	186246	QSLV4-G $\frac{1}{8}$ -8	1
G $\frac{1}{4}$	2.9	6	186245	QSLV4-G $\frac{1}{4}$ -6	1
	4.1	8	186247	QSLV4-G $\frac{1}{4}$ -8	1
	5	10	186249	QSLV4-G $\frac{1}{4}$ -10	1
G $\frac{3}{8}$	4.1	8	186248	QSLV4-G $\frac{3}{8}$ -8	1
	5.1	10	186250	QSLV4-G $\frac{3}{8}$ -10	1
	6	12	186251	QSLV4-G $\frac{3}{8}$ -12	1
G $\frac{1}{2}$	6.2	12	186252	QSLV4-G $\frac{1}{2}$ -12	1

Multiple distributor QSLV6

6 outlets, rotatable 360°



Connection D1	Nominal size [mm]	Tubing O.D. D2	Part No.	Type	PU ¹⁾
R thread					
R $\frac{1}{8}$	2.3	4	153241	QSLV6- $\frac{1}{8}$ -4	1
	2.9	6	153242	QSLV6- $\frac{1}{8}$ -6	1
	4	8	153244	QSLV6- $\frac{1}{8}$ -8	1
R $\frac{1}{4}$	2.9	6	153243	QSLV6- $\frac{1}{4}$ -6	1
	4	8	153245	QSLV6- $\frac{1}{4}$ -8	1
	5.2	10	153247	QSLV6- $\frac{1}{4}$ -10	1
R $\frac{3}{8}$	4.1	8	153246	QSLV6- $\frac{3}{8}$ -8	1
	5.2	10	153248	QSLV6- $\frac{3}{8}$ -10	1
	6.3	12	153249	QSLV6- $\frac{3}{8}$ -12	1
R $\frac{1}{2}$	6.3	12	153250	QSLV6- $\frac{1}{2}$ -12	1
G thread with sealing ring					
G $\frac{1}{8}$	2.3	4	186253	QSLV6-G $\frac{1}{8}$ -4	1
	2.9	6	186254	QSLV6-G $\frac{1}{8}$ -6	1
	4	8	186256	QSLV6-G $\frac{1}{8}$ -8	1
G $\frac{1}{4}$	2.9	6	186255	QSLV6-G $\frac{1}{4}$ -6	1
	4	8	186257	QSLV6-G $\frac{1}{4}$ -8	1
	5.2	10	186259	QSLV6-G $\frac{1}{4}$ -10	1
G $\frac{3}{8}$	4.1	8	186258	QSLV6-G $\frac{3}{8}$ -8	1
	5.2	10	186260	QSLV6-G $\frac{3}{8}$ -10	1
	6.3	12	186261	QSLV6-G $\frac{3}{8}$ -12	1
G $\frac{1}{2}$	6.3	12	186262	QSLV6-G $\frac{1}{2}$ -12	1

1) Packaging unit per part

Ordering data

Multiple distributor QSQ

4 outlets, rotatable 360°

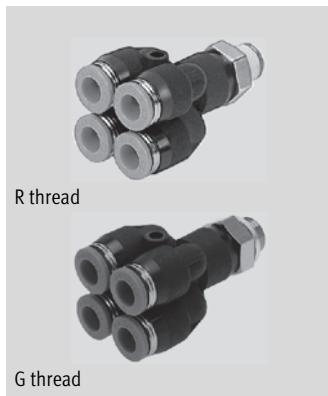

Connection D1	Nominal size [mm]	Tubing O.D. D2	Part No.	Type	PU ¹⁾
R thread					
R ¹ / ₈	2	4	153206	QSQ- ¹ / ₈ -4	1
	2.1	6	153208	QSQ- ¹ / ₈ -6	1
R ¹ / ₄	2	4	153207	QSQ- ¹ / ₄ -4	1
	2.1	6	153288	QSQ- ¹ / ₄ -6	1
G thread with sealing ring					
G ¹ / ₈	1.4	4	186220	QSQ-G ¹ / ₈ -4	1
	3.4	6	186222	QSQ-G ¹ / ₈ -6	1
G ¹ / ₄	1.3	4	186221	QSQ-G ¹ / ₄ -4	1
	3	6	186263	QSQ-G ¹ / ₄ -6	1



Tubing O.D. D1	Nominal size [mm]	Tubing O.D. D2	Part No.	Type	PU ¹⁾
Push-in connector, reducing					
6	1.4	4	153209	QSQ-6-4	1
8	3.2	6	153210	QSQ-8-6	1

1) Packaging unit per part



- Sealing materials
- Pipe and tubing cutters
- Tubing clips/straps

→ [<type>](http://www.festo.com/catalogue/)

Product range overview

Type	Function	M3	M5	M7	G1/8	G1/4	G3/8	G1/2	G3/4	G1	→ Page/ online
Sealing materials											
O	Sealing ring	■	■	-	■	■	■	■	■	■	937
CRO	Sealing ring	-	■	-	■	■	■	■	■	■	
OL	Sealing ring, sealing ring assortment	-	■	-	■	■	■	■	■	-	
OK	Sealing ring, sealing ring assortment	■	■	■	■	■	■	■	■	-	938
GWB	Thread sealing tape	-									
Pipe and tubing cutters											
PAN-VOS	Tubing cutter	For cutting plastic tubing PAN-V0, flame-retardant									pan-vos
ZDS	Disconnecting pliers	For removing plastic tubing from barbed fittings									zds
ZMS	Connecting pliers	For connecting plastic tubing to barbed fittings									zms
ZR	Pipe cutter	For cutting to length plastic piping PQ-PA									zr
ZRS	Pipe/tubing cutter	For cutting to length plastic tubing with and without textile insert up to O.D. 20 mm									zrs
Tubing clips/straps											
PB	Tubing strap	Bundle Ø 30 ... 100 mm									pb
PKB	Spiral wrap for tubing	Max. bundle Ø 50 mm									pkb
PKS	Tubing support	For tubing O.D. 6 ... 11 mm									pks
NPAA	Tubing support	Mounting component for guiding cables and tubing									npaw
KK	Multi-tube holder	For tubing O.D. 4.3 ... 17.6 mm									kk

Ordering data

Sealing ring O/CRO



For thread	Suitable for use in the food industry	Part No.	Type	PU ¹⁾
PA				
M3	–	30290	O-M3-B	1
PVC				
M5	–	3565	O-M5	1
		534226	O-M5-500	500
G $\frac{1}{8}$	–	2223	O- $\frac{1}{8}$	1
		534227	O- $\frac{1}{8}$ -500	500
G $\frac{1}{4}$	–	2224	O- $\frac{1}{4}$	1
		534228	O- $\frac{1}{4}$ -200	200
G $\frac{3}{8}$	–	2225	O- $\frac{3}{8}$	1
		534229	O- $\frac{3}{8}$ -200	200
G $\frac{1}{2}$	–	2226	O- $\frac{1}{2}$	1
		534230	O- $\frac{1}{2}$ -100	100
G $\frac{3}{4}$	–	2227	O- $\frac{3}{4}$	1
G1	–	210893	O-1	1
PVDF				
M5	As per manufacturer's declaration	165191	CRO-M5	1
G $\frac{1}{8}$		575895	CRO- $\frac{1}{8}$	1
G $\frac{1}{4}$		165193	CRO- $\frac{1}{4}$	1
G $\frac{3}{8}$		165194	CRO- $\frac{3}{8}$	1
G $\frac{1}{2}$		165195	CRO- $\frac{1}{2}$	1
G $\frac{3}{4}$		165196	CRO- $\frac{3}{4}$	1
G1		165197	CRO-1	1

Sealing ring OL

with metal body, based on standard ISO 16030



For thread	Part No.	Type	PU ¹⁾
Stainless steel, NBR			
M5	34634	OL-M5	1
	534231	OL-M5-500	500
G $\frac{1}{8}$	33840	OL- $\frac{1}{8}$	1
	534232	OL- $\frac{1}{8}$ -500	500
G $\frac{1}{4}$	34635	OL- $\frac{1}{4}$	1
	534233	OL- $\frac{1}{4}$ -200	200
Aluminium, NBR			
G $\frac{3}{8}$	34636	OL- $\frac{3}{8}$	1
	534234	OL- $\frac{3}{8}$ -200	200
G $\frac{1}{2}$	34637	OL- $\frac{1}{2}$	1
	534235	OL- $\frac{1}{2}$ -100	100
G $\frac{3}{4}$	34638	OL- $\frac{3}{4}$	1

Sealing ring assortment OL-S1



Contents	Quantity	Part No.	Type
OL-M5	50	161355	OL-S1
OL- $\frac{1}{8}$	100		
OL- $\frac{1}{4}$	100		
OL- $\frac{3}{8}$	40		
OL- $\frac{1}{2}$	30		
OL- $\frac{3}{4}$	10		

1) Packaging unit per part

Sealing material

FESTO

Ordering data

Sealing ring OK

with support ring, based on standard ISO 16030



For thread	Part No.	Type	PU ¹⁾
Stainless steel, NBR			
M3	130849	OK-M3	1
M5	130850	OK-M5	1
M7	130851	OK-M7	1
PA, TPE-U(PU)			
G1/8	531771	OK-1/8	1
G1/4	531772	OK-1/4	1
G3/8	531773	OK-3/8	1
G1/2	531774	OK-1/2	1
G3/4	531775	OK-3/4	1

Sealing ring assortment OK-S1



Contents	Quantity	Part No.	Type
OK-M3	50	570465	OK-S1
OK-M5	100		
OK-M7	50		
OK-1/8	100		
OK-1/4	100		
OK-3/8	40		
OK-1/2	30		
OK-3/4	10		

Thread sealing tape GWB-0,1

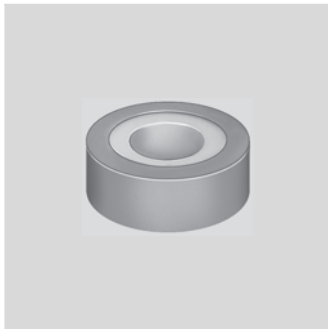

Width [mm]	Thickness [mm]	Length [m]	Part No.	Type
10	0.1	12.5	9076	GWB-0,1

¹⁾ Packaging unit per part



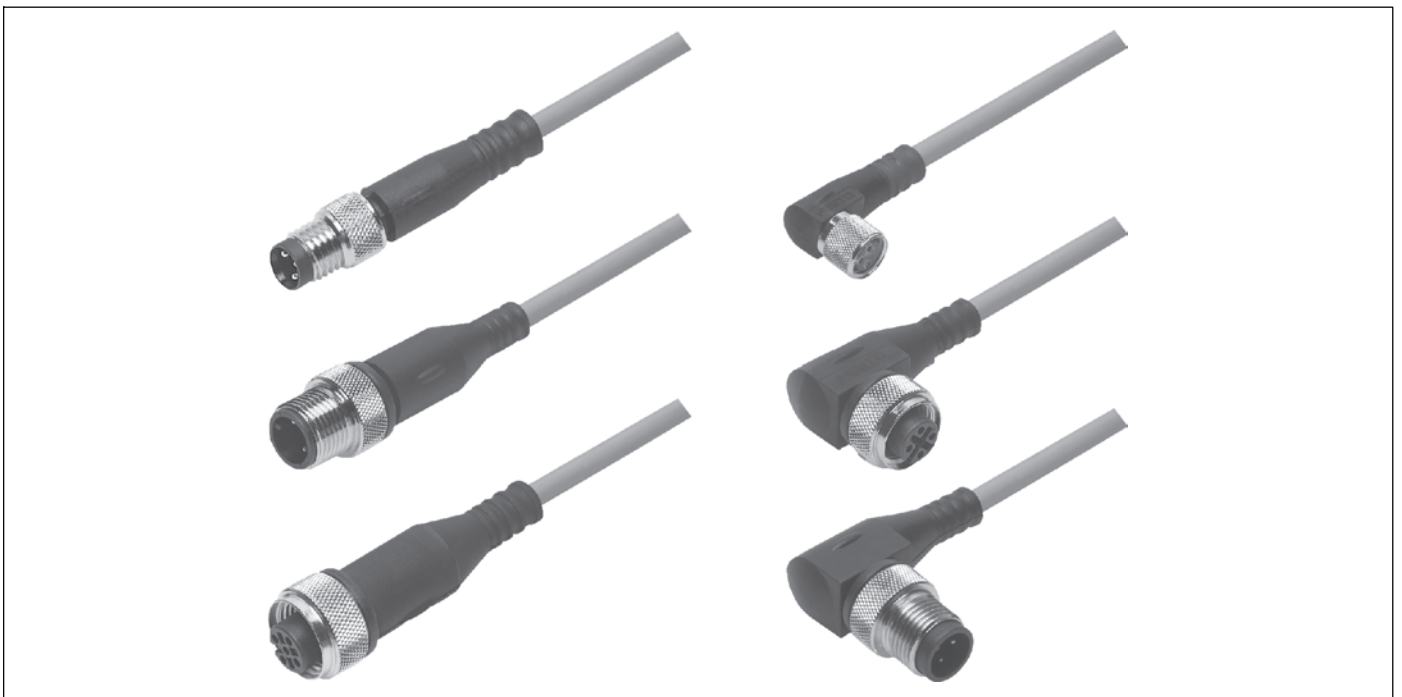

14 Electrical connection technology

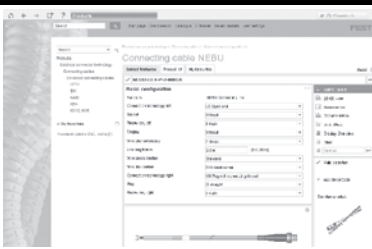

Software tool

Configurator		<p>Design a product with numerous features reliably and quickly with the help of the configurator. Select all the required product features step-by-step. The use of logic checks ensures that only correct configurations are available for selection.</p> <p>The configurator is part of the electronic catalogue and is not available as a separate software program.</p>
---------------------	---	--





Universal connecting cables

				
Type	Connecting cable NEBU	Plug socket with cable SIM	Flat cable KASI	Connecting cable KEA
Electrical connection	Socket: straight, angled, rotatable, plug: straight, angled, M5x0.5, M8x1, M12x1, 7/8", 2-pin, 3-pin, 4-pin, 5-pin, 8-pin, rotatable thread, open end	3-pin, 4-pin, 5-pin, 8-pin, straight socket, M12x1, socket M8, clip	2-pin, open cable end	25-pin, socket, Sub-D
Cable length	0.1 ... 30 m	2 ... 10 m	100 m	5 ... 10 m
Description	<ul style="list-style-type: none"> • Designs for static, standard, energy chain and robot applications • Design with switching status indication • Designs for connecting sensors and actuators 	<ul style="list-style-type: none"> • Pre-assembled at both ends 	<ul style="list-style-type: none"> • For AS-Interface • 2-wire • Reverse polarity protected • Contact using insulation displacement technology • No need to strip cable and wire insulation • Two different colours: yellow (preferred for the AS-Interface network) and black (for auxiliary power supply) 	<ul style="list-style-type: none"> • For multi-pin plug connection • Type of mounting: 2 screws M3x16 • Operating voltage range 250 V AC/DC
→ Page/online	949	sim	kasi	kea



Universal connecting cables

		
Type	Connecting cable KM8, KM12	
Electrical connection	3-pin, 4-pin, 8-pin, 4-wire, M8x1, M12x1, plug: straight, socket: straight, angled	
Cable length	0.5 ... 5 m	
Description	<ul style="list-style-type: none"> • For connecting inputs and outputs or for connecting individual valves or sensors • Pre-assembled at both ends: straight plug with straight or angled socket • Type of mounting: union nut, threaded connector 	
→ Page/online	km8	

Connecting cables for control systems

				
Type	Connecting cable NEBC	Cable SBOA	Connecting cable KSPC-SECST, KSPC-AIF	Connecting cable FEC-KBG
Electrical connection	5-pin, 9-pin, 15-pin, 3-wire, socket: straight, plug: straight, angled, open end, cable, M9, M12x1, Sub-D, square design	Straight plug/straight socket/straight socket, angled plug/straight socket	15-pin, plug, straight socket/angled socket, 5-pin/5-pin	RJ11 plug/Sub-D, socket, 15-pin, RJ12 plug/Sub-D, socket, 15-pin
Cable length	0.3 ... 5 m	2 m	1.5 m, 5 m, 8 m	1.2 m, 1.8 m
Description	<ul style="list-style-type: none"> For I/O interface For connecting motor controller CMMS-ST to any controller 	<ul style="list-style-type: none"> Used as an Ethernet diagnostic cable, for integration in a CPI system, for I/O extension, for compact vision system type SBOC-Q, SBOI-Q 	<ul style="list-style-type: none"> For connecting motor controller SEC-ST to axis controller SPC200 For connecting motor controller SPC200 to axis interface SPC-AIF 	<ul style="list-style-type: none"> For connecting terminal CPX to operator unit FED
→ Page/online	nebc	sboa	kspc	fec-kbg

Connecting cables for control systems

				
Type	Addressing cable KASI-ADR	Control cable KES	Programming cable KDI	Programming cable PS1-ZK11
Electrical connection	4-pin/4-pin/2-pin, straight socket/angled plug/straight socket		4-pin, 5-pin, 9-pin, 25-pin, straight socket, straight plug, M8x1, M12x1, Sub-D	
Cable length	2.5 m	2.5 ... 10 m	2.5 ... 5 m	1.5 m
Description	<ul style="list-style-type: none"> For AS-Interface For any slaves such as individual valve interface, valve terminal with AS-Interface Reverse polarity protected 	<ul style="list-style-type: none"> For I/O interface for connecting motor controller SFC-DC to any controller For I/O interface for connecting motor unit MTR-DCI to any controller 	<ul style="list-style-type: none"> Pre-assembled at both ends For diagnostic interface For servo motor MTR-DCI 	<ul style="list-style-type: none"> Connecting cable for motor controller CMMS-ST
→ Page/online	kasi-adr	kes	kdi	cmms-st

Connecting cables for control systems

	
Type	Connecting cable KV-M12
Electrical connection	Straight plug/straight socket
Cable length	1.5 ... 3.5 m
Description	<ul style="list-style-type: none"> Plug socket with cable for diagnostic interface (to electrical terminal CPX) Pre-assembled at both ends 5-pin/4-wire Round plug Mounting via union nut M12
→ Page/online	kv-m12

Connecting cables for motors

Type	Encoder cable NEBM	Motor cable KMTR	Motor cable KMTRE	Supply cable KPWR
Electrical connection	Connection technology, left-hand end: M12, A-coded, M23, M40, Sub-D, ITT M3, connection technology, right-hand end: open end, M12, A-coded, Sub-D, ITT M3			
Cable length	5 ... 15 m	2.5 ... 10 m	5 ... 10 m	2.5 ... 10 m
Description	<ul style="list-style-type: none"> For servo motor EMMS-AS and stepper motor EMMS-ST Suitable for use with energy chains 	<ul style="list-style-type: none"> For motor controller SFC-DC 	<ul style="list-style-type: none"> Screened cable Can be used at -40 ... +125°C Suitable for use with energy chains Protection class IP67 For stepper motor MTRE-ST 	<ul style="list-style-type: none"> For motor unit MTR-DCI For motor controller SFC-DC for connecting load and logic supply
→ Page/online	nebm	kmtr	kmtre	kpwr





Connecting cables for positioning

Type	Connecting cable NEBP
Electrical connection	Plug: screw connector M9x0.5, socket: screw connector M16x0.75
Cable length	2 m
Description	<ul style="list-style-type: none"> Connection between linear drive DGPI, DGPIIL or displacement encoder MME and measuring module CPX-CMIX
→ Page/online	nebp



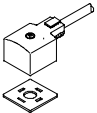

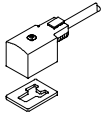
Connecting cables for valves

Type	Plug socket with cable KMYZ-2, KMYZ-3, KMYZ-4, KMYZ-9	Plug socket with cable KMEB-1, KMEB-2, KMEB-3	Plug socket with cable KME	Plug socket with cable KMF
Electrical connection	2-pin, 3-pin, 2-wire, socket: angled, plug: straight, angled, cable, square design, M8x1, open end, square design/open end, square design/square design	2-pin, 3-pin, 4-pin, 5-pin, angled socket, type C, to DIN EN 175301-803	3-pin, angled socket, type C, to DIN EN 175301-803	Socket
Cable length	0.2 ... 10 m	0.5 ... 10 m	2.5 ... 10 m	2.5 ... 10 m
Description	<ul style="list-style-type: none"> For valve with ZB solenoid coil: MZBH, MOZBH For valve with ZC solenoid coil: CPE10-M1BH, CPE14-M1BH, MH2, MH3 Mounting via central screw 	<ul style="list-style-type: none"> For valve with EB solenoid coil: CPE18, CPE24, MEBH, MOEBH, JMEBH, JMEBDH, JMN2DH Polyvinyl chloride or polyurethane cable Mounting via central screw 	<ul style="list-style-type: none"> For valve with E solenoid coil: MEH, MOEH, JMEH Mounting via central screw Polyvinyl chloride cable Temperature range -20 ... +80 °C 	<ul style="list-style-type: none"> For valve with F solenoid coil: MFH, MOFH, JMFH, JMFHD, NVF3, MUFH Mounting via central screw Polyvinyl chloride cable Temperature range -20 ... +80 °C
→ Page/online	kmyz-2	kmeb-1	kme	kmf





Connecting cables for valves

				
Type	Plug socket with cable KMC	Plug socket with cable KMH	Plug socket with cable KMV	Electrical plug-in base MHAP-PI
Electrical connection	Socket, type A	2-pin, 3-pin, socket	Socket, type B	2-pin, 3-pin, socket
Cable length	2.5 ... 10 m	0.5 ... 5 m	2.5 ... 10 m	0.5 ... 1 m
Description	<ul style="list-style-type: none"> For valve with D solenoid coil: MDH, MODH, JMDH For valve with N1 solenoid coil: MN1H, JMN1H, JMN1DH Polyvinyl chloride cable Mounting via central screw Temperature range -20 ... +80 °C 	<ul style="list-style-type: none"> For miniature valve MHA1 and MHP1 For fast-switching valve MHA2 and MHP2 Mounting via clip Temperature range -40 ... +80 °C Polyvinyl chloride cable 	<ul style="list-style-type: none"> For valves with V solenoid coils Mounting via central screw M3 Polyvinyl chloride cable Temperature range -20 ... +80 °C 	<ul style="list-style-type: none"> Plug base with cable for connecting individual valve Pre-assembled 2-pin or 3-pin socket Mounting via clip
→ Page/online	kmc	kmh	kmv	mhap



Connecting cables for valves

				
Type	Plug socket with cable KMPPE	Connecting cable KMPYE-AIF, KMPYE-5, KMPYE-...	Connecting cable MHJ9-KMH	Connecting cable NEBV-C1, NEBV-B2, NEBV-Z2, NEBV-H1, NEBV-M8
Electrical connection	8-pin, angled, socket M16		2-pin/2-pin/4-wire, straight socket/ straight socket/cable	2-wire, 3-wire, 4-wire, 5-wire, socket: straight, angled, plug: straight, cable, M8x1, M12x1, type B/A-coded, type C/A-coded, to DIN EN 175301-803/M12x1, square design MSZC/A-coded
Cable length	2.5 m, 5 m	0.3 ... 5 m	0.5 ... 2.5 m	0.5 ... 10 m
Description	<ul style="list-style-type: none"> For the proportional pressure regulators MPPE and MPPES Temperature range -30 ... +80 °C Mounting via union nut M16x0.75 Polyvinyl chloride cable 	<ul style="list-style-type: none"> Connecting cable for connecting proportional directional control valve MPYE to the axis interface of axis controller SPC200 Plug socket with cable, screened, for proportional directional control valve MPYE with 5 m cable 	<ul style="list-style-type: none"> For valves MHJ9 With plug sockets KMH With control electronics for two valves 	<ul style="list-style-type: none"> Connecting cable for AS-Interface, for valves with ZC solenoid coils (CPE10, CPE14), for valves VUVG Pre-assembled NEBV-C1, B2, -Z2: based on EN 175301-803, EN 61076-2-101
→ Page/online	kmppe	kmpye	mhj9-kmh	nebv

Connecting cables for valve terminals

				
Type	Connecting cable NEBV-S1	Connecting cable KMP3, KMP4, KMP6	Connecting cable KRP	Connecting cable KVI
Electrical connection	10-pin, 15-pin, 25-pin, 26-pin, 37-pin, 44-pin, socket: straight, angled	15-pin, 25-pin, 26-pin, 9-pin, socket, Sub-D	2-pin, angled socket	Straight plug/straight socket, angled plug/angled socket, 5-pin round plug
Cable length	2.5 m, 5 m, 10 m	2.5 ... 10 m	2.5 ... 5 m	0.25 ... 8 m
Description	<ul style="list-style-type: none"> Connecting cable for multi-pin plug connection Pre-assembled 	<ul style="list-style-type: none"> Plug socket with cable for multi-pin plug connection Pre-assembled Mounting via union nut, with 2 screws 	<ul style="list-style-type: none"> Plug socket with cable for connecting relay plates (valve terminal CPV10 and CPV14) Pre-assembled Mounting via self-tapping central screw 	<ul style="list-style-type: none"> For fieldbus connection (CP bus valve terminal CPV and CPI installation system) Pre-assembled at both ends Suitable for use with energy chains
→ Page/online	nebv	kmp	krp	kvi

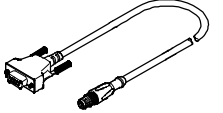

Connecting cables for valve terminals

				
Type	Connecting cable K VIA	Fieldbus adapter FBA-CO, FBA-PB	T-adapter FB-TA	Connecting cable VMPA-KMS1, VMPA-KMS2, VMPAL-KM, VMPAL-KMSK
Electrical connection	Straight plug, straight socket, angled socket	9-pin/5-pin, Sub-D/M12x1	5-pin, M1 2x1/M8x1, plug/socket	25-pin, 44-pin, Sub-D socket
Cable length	5 ... 10 m		1.4 m	2.5 ... 10 m
Description	<ul style="list-style-type: none"> For inputs/outputs (analogue connections) Pre-assembled at both ends 4-pin/5-pin round plug Suitable for use with energy chains 	<ul style="list-style-type: none"> 9-pin Sub-D plug to 5-pin round plug/M12 socket 	<ul style="list-style-type: none"> For fieldbus connection (for valve terminal CPV and CP installation system) Branch line for connecting and disconnecting fieldbus components With open cable end or with 5-pin push-in connector 	<ul style="list-style-type: none"> Plug socket with cable for multi-pin connection (to valve terminal MPA) Variant suitable for use with energy chains Cable outlet straight or to side Pre-assembled at one end Polyvinyl chloride or polyurethane cable
→ Page/online	kvia	fba	fb-ta	vmpa-kms



Connecting cables for sensors

	
Type	Connecting cable NEBS
Electrical connection	Socket, square design L1, 4-pin, socket, square design L2, 4-pin, socket, square design L2, 5-pin
Cable length	2.5 ... 5 m
Description	<ul style="list-style-type: none"> For pressure sensor SPAB Protection class IP40
→ Page/online	nebs





Universal plug connectors

Type	 Plug socket with cable NEFU	 Plug NECU, NECU-HX	 Push-in T-connector NEDU	 Multi-pin plug distributor NEDU
Electrical connection	Socket, M12x1, 4-pin, A-coded	3-pin, 4-pin, 5-pin, 8-pin, 9-pin, Sub-D, straight socket, straight plug, spring-loaded terminal, screw terminal, insulation displacement connector, 7/8", AIDA push-pull, M8x1, M12x1, for self-assembly, can be screened, square design	4-pin/3-pin, 4-pin/4-pin, A-coded/A-coded, M12x1/M12x1, M12x1/M8x1, M8x1/M8x1, plug/socket	3-pin, 8-pin, M8, M12, socket, plug
Connection cross section		0.08 ... 2.5 mm ²		
Protection class	IP65, in assembled state	IP40, IP65, IP67, IP68	IP65, IP67	IP68
Description	<ul style="list-style-type: none"> • Cable socket for branching the AS-Interface network at any desired point • Reconnecting AS-Interface flat cable to 5-pin M12 socket • Reverse polarity protected 	<ul style="list-style-type: none"> • Power supply socket for fieldbus connection • Plug and socket for power supply • Can be assembled with any cable lengths • NECU-HX: reconnectable M8 and M12 round plug connectors with Harax® quick connection technology for low-voltage applications 	<ul style="list-style-type: none"> • For fieldbus connection • Branch line for connecting and disconnecting fieldbus components 	<ul style="list-style-type: none"> • Multi-pin plug distributor • Particularly compact
→ Page/online	nefu	necu	nedu	nedu

Universal plug connectors

Type	 Plug SEA	 Cable distributor ASI-KVT	 Plug socket with cable ASI-SD
Electrical connection	3-pin, 4-pin, 5-pin, angled socket, straight plug, screw terminal, insulation displacement connector, solder connection, type A, M8x1, M12x1	2-pin, 4-pin, socket M12, insulation displacement technology	2-pin, 4-pin, 5-pin, straight socket, straight socket/insulation displacement technology, screw terminal
Connection cross section	0.14 ... 0.75 mm ²	1.5 mm ²	0.75 ... 1.5 mm ²
Protection class	IP65, IP67	IP65, in assembled state	IP65, IP67
Description	<ul style="list-style-type: none"> • Sensor plug, socket for inputs/outputs • Can be assembled with any cable lengths 	<ul style="list-style-type: none"> • Flat cable distributor for branching or for reconnecting AS-Interface flat cables • Reverse polarity protected 	<ul style="list-style-type: none"> • For AS-Interface • Flat cable socket for connecting AS-Interface stations to the AS-Interface bus system • M12 connection • Reverse polarity protected • Detachable connection
→ Page/online	sea	asi-kvt	asi-sd



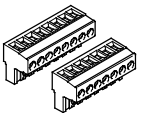

Plug connectors for control systems

Type	 Plug NECC	 Plug PS1-SAC, PS1-ZC	 Plug FBS-SUB-9-WS	 Plug FBS-RJ45
Electrical connection	11-pin, 9-pin/9-pin, spring-loaded terminal, plug, Sub-D/screw terminal	10-pin/10-pin, 10-pin/30-pin, socket/terminal strip	5-pin, type A, M12x1, straight plug/screw terminal	5-pin, type A, M12x1, straight plug/screw terminal
Connection cross section	0.2 ... 2.5 mm ²	0.08 ... 0.75 mm ²	0.75 mm ²	0.75 mm ²
Protection class	IP40		IP40, in assembled state, to IEC 60529	IP40, IP65, IP67, in assembled state
Description	<ul style="list-style-type: none"> Encoder plug for motor controller CMMS-ST, CMMS-AS Plug for multi-axis controllers CMXR for interface housing CAMI-C, 11-pin Plug for multi-axis controllers CMXR and for modular controllers CE CX for peripheral modules 2-pin, 4-pin, 6-pin, 8-pin, 11-pin, 18-pin 	<ul style="list-style-type: none"> For power supply Cable connection using clamping technology Individually or as a set 	<ul style="list-style-type: none"> Plug connector for bus connection CAN Bus and Profibus Cable connection 2x horizontal or 2x vertical Printed circuit terminal block with screw connector 	<ul style="list-style-type: none"> Ethernet plug with 8-pin RJ45 connection High transmission quality Detachable connection
→ Page/online	necc	ps1	fbs-sub-9-ws	fbs-rj



Plug connectors for control systems

Type	 Plug assortment NEKM
Electrical connection	2 ... 9-pin, screw connector
Connection cross section	0.2 ... 2.5 mm ²
Protection class	
Description	<ul style="list-style-type: none"> For motor cable, encoder cable, power supply, reference switch, STO safety function Comprising plug for power supply and plug for motor connection
→ Page/online	nekm

Plug connectors for valves

Type	 Plug socket MSSD	 Soldering base PCBC	 Multi-pin plug socket NECA	 Angled socket MPPE-3-B
Electrical connection	3-pin, 4-pin, angled socket, type A, type B, type C, to DIN EN 175301-803, to DIN EN 61984, square design	2-pin, 3-pin	9-pin/9-pin, Sub-D/screw terminal	8-pin, angled socket, solderable
Connection cross section	0.22 ... 1.5 mm ²		0.34 ... 1 mm ²	0.75 mm ²
Protection class	IP40, IP65, IP67, in assembled state, to IEC 60529	IP40	IP65	IP67
Description	<ul style="list-style-type: none"> For valves with F, D, N1, V, E, EB, N2, Y, Z, ZB, ZC, MD-2, MH-2 solenoid coils For connecting individual valves Cable connection using clamping screws, insulation displacement technology or push-in connector With or without LED 	<ul style="list-style-type: none"> For mounting miniature valves MHA1 and MHP1 on a PCB with plug connection underneath (-PI) For valve terminal CPA-SC for plug-in connection 	<ul style="list-style-type: none"> For soft-start/quick exhaust valve MS6-SV, MS series Electrical connection via 9-pin Sub-D, 9-pin screw terminal 	<ul style="list-style-type: none"> For the proportional pressure regulators MPPE and MPPES Mounting via union nut
→ Page/online	mssd	pcbc	ms6-sv	mppe-3-b



Plug connectors for valves

			
Type	Time delay insert MFZ	Illuminating seal MF-LD, MC-LD, MV-LD, ME-LD, MEB-LD	Indicator insert MCL, MCLZ, MFL, MFLZ
Electrical connection	For connector socket or device plug, type F	Type A, B, C, to DIN EN 175301-803, square design, MSC	Plug-in to DIN 43650, plug-in for F coil
Connection cross section			
Protection class	IP64	IP65	IP64 (without seal: IP40)
Description	<ul style="list-style-type: none"> • Electronic timer with adjustable time delay of between 0 ... 10 s • For mounting between the solenoid coil and connector socket or device plug 	<ul style="list-style-type: none"> • For mounting between the plug socket and solenoid coil • The seal is illuminated yellow when the power is switched on • For F, D, N1, V, E, EB solenoid coils 	<ul style="list-style-type: none"> • For mounting between the solenoid coil and plug connection • With yellow LED indicator • Variant with integrated protective circuit
→ Page/online	mfz	mc-ld	mcl



Plug connectors for valve terminals

				
Type	Bus connection FBSD-KL	Plug, plug socket FBS, FBSD	Power supply socket NTSD	Bus connection FBA-1, FBA-2
Electrical connection	5-pin/5-pin, angled socket/screw terminal	4-pin, 5-pin, socket: straight, angled, plug: straight, screw terminal, type A, M12x1	4-pin, 5-pin, socket: straight, angled, plug: straight, screw terminal	9-pin/5-pin, straight socket/straight plug, straight socket/plug and socket, Sub-D/-, Sub-D/M12x1
Connection cross section	0.2 ... 2.5 mm ²	0.75 mm ² , 0.2 ... 2.5 mm ²	0.75 ... 2.5 mm ²	
Protection class	IP20	IP20, IP67, in assembled state	IP67	IP40, IP65, IP67
Description	<ul style="list-style-type: none"> • 5-pin angled socket, 5-pin screw terminal 	<ul style="list-style-type: none"> • For fieldbus connection • Straight and angled design • Can be assembled with any cable lengths 	<ul style="list-style-type: none"> • Straight and angled design • For power supply • Can be assembled with any cable lengths 	<ul style="list-style-type: none"> • Can be assembled with any cable lengths
→ Page/online	fbzd-kl	fbs	ntsd	fba-1

Plug connectors for valve terminals

				
Type	Plug FBS-SUB	Sensor socket SIE-GD, SIE-WD	Cover cap ISK	Plug socket, plug SD-SUB
Electrical connection	Fieldbus plug with 9-pin Sub-D connection	4-pin, straight socket, angled socket, M12x1		25-pin, plug, Sub-D
Connection cross section		0.25 ... 0.75 mm ²		
Protection class	IP65, IP67, in assembled state	IP67		IP65
Description	<ul style="list-style-type: none"> • Variants for PROFIBUS DP, INTERBUS nodes CPX and CPV, CC-Link CPX and CPV, CPX-FEC • Position of DIL switches can be read externally • Easy mounting 	<ul style="list-style-type: none"> • For customised fabrication of cables • Pin adapter for fieldbus connection • With screw terminals • Straight or angled design 	<ul style="list-style-type: none"> • For sealing unused ports/openings • Thread M8, M12 	<ul style="list-style-type: none"> • Socket for multi-pin plug connection • Plug for inputs/outputs • Can be assembled with any cable lengths
→ Page/online	fbs-sub	sie-gd	isk	sd-sub

Plug connectors for sensors

	 Angled socket PEV-WD	 Angled socket SD-4-WD
Type	4-pin, angled socket	4-pin, plug, Sub-D
Electrical connection	4-pin, angled socket	4-pin, plug, Sub-D
Connection cross section		
Protection class	IP65	IP65
Description	<ul style="list-style-type: none"> • For pressure switch PEV • 15 ... 30, 180 V DC, 230 V AC • Angled design • Optionally with LED indicator 	<ul style="list-style-type: none"> • For swivel module DSMI • Angled design
→ Page/online	pev*wd	sd-4-wd



- Connecting cables for basic, standard, energy chain and robot applications
- Versions with switching status display
- Cable length 01 ... 30 m freely selectable
- ★ Quick ordering of basic designs → 955

→ www.festo.com/catalogue/nebu

Product range overview

Type	Electrical connection	Cable characteristics	Electrical connection	Number of wires	Cable length [m]	→ Page/online
	Left		Right			
NEBU-LE	Open end	Basic	Plug M8x1	3, 4, 5	0.1 ... 30	950
			Plug M1 2x1			
		Standard	Plug M8x1	3, 4, 5	0.1 ... 30	950
			Plug M1 2x1			
NEBU-M5	Socket M5x0.5	Standard	Open end	3	5	nebu-m5
			Plug M8x1	3	1	
			Plug M1 2x1	4	1	
NEBU-M8	Socket M8x1	Basic	Open end	2, 3, 4	0.1 ... 30	950
			Plug M8x1			
			Plug M1 2x1			
		Standard	Open end	2, 3, 4	0.1 ... 30	950
			Plug M8x1			
			Plug M1 2x1			
		Suitable for use with energy chains	Open end	3, 4	0.1 ... 30	950
			Plug M8x1			
			Plug M1 2x1			
		Suitable for robot applications	Open end	3, 4	0.1 ... 30	950
			Plug M8x1			
			Plug M1 2x1			
With switching status display	Open end	3	0.1 ... 30	950		
	Plug M8x1					
	Plug M1 2x1					
NEBU-M12	Socket M1 2x1	Basic	Open end	3, 4, 5	0.1 ... 30	950
			Plug M8x1			
			Plug M1 2x1			
		Standard	Open end	3, 4, 5	0.1 ... 30	950
				8	2, 5	
			Plug M8x1	3, 4, 5	0.1 ... 30	
		Suitable for use with energy chains	Open end	3, 4, 5	0.1 ... 30	950
			Plug M8x1			
			Plug M1 2x1			
		Suitable for robot applications	Open end	3, 4, 5	0.1 ... 30	950
			Plug M8x1			
			Plug M1 2x1			
With switching status display	Open end	3	0.1 ... 30	950		
	Plug M8x1					
	Plug M1 2x1					
NEBU-G78	Socket 7/8"	Standard	Open end	5	2	nebu-g78

Connecting cables NEBU

Technical data

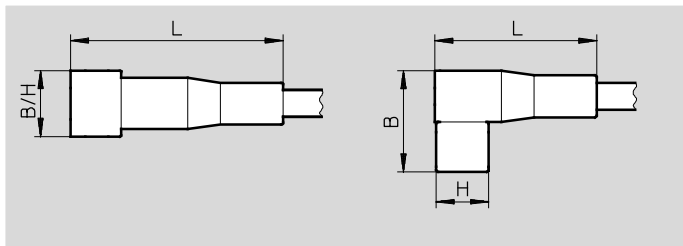

Technical data		NEBU-LE	NEBU-M8	NEBU-M12
Type				
Conforms to standard		EN 61076-2-101	–	EN 61076-2-101
		EN 61076-2-104	EN 61076-2-104	–
		EN 61984		
Cable characteristics	NEBU-...-P	Basic		
	NEBU-...-K	Standard		
	NEBU-...-E	Suitable for use with energy chains, cables halogen-free and oil-resistant		
	NEBU-...-R	Suitable for robot applications, cables halogen-free and oil-resistant		

Electrical connection	Socket M8x1		Plug M8x1		Socket M12x1		Plug M12x1		
	Straight	Angled	Straight	Angled	Straight	Angled	Straight	Angled	
Cable composition	2x0.25 mm ²				–				
	3x0.25 mm ²				3x0.25 mm ²				
	4x0.25 mm ²				4x0.25 mm ²				
	–				5x0.25 mm ²				
	–				5x1.00 mm ²				
Conductor nominal cross section	[mm ²]	0.25				0.25			
	[mm ²]	–				1	–	1	–
Cable diameter	[mm]	4.5				4.5			
Cable length	[m]	0.1 ... 30				0.1 ... 30			
Plug coding		–				A			
Length L/width W/height H	[mm]	35/9/9	27/17/9	42/10/10	27/24/10	48/15/15	38/26/15	55/15/15	38/33/15

Type	NEBU-...P	NEBU-...N	NEBU-...L	NEBU-...P2
Display	LED, PNP	LED, NPN	LED, DC	2x LED, PNP
Ready status display	Green LED	Green LED	–	Green LED
Switching status display	Yellow LED	Yellow LED	Yellow LED	Yellow LED
	–	–	–	Blue LED

Electrical data		NEBU-M8					
Type		2x0.25 mm ²			4x0.25 mm ²		
Cable composition		2x0.25 mm ²			4x0.25 mm ²		
Display		L	–	P, N	–	–	P, N
Operating voltage range ¹⁾	[V AC]	–	0 ... 60	–	0 ... 30	–	–
	[V DC]	21.6 ... 30	0 ... 60	10 ... 30	0 ... 30	–	10 ... 30
Surge capacity ¹⁾	[kV]	0.8	1.5	0.8	0.8	–	0.8
Acceptable current load at 40 °C ¹⁾	[A]	3					
Degree of contamination		3					

1) When different connection technologies are combined the lower value applies.

Technical data

Type	NEBU-M12					
Cable composition	3x0.25 mm ²		4x0.25 mm ²		5x0.25 mm ²	5x1.00 mm ²
Display	–	P, N	–	P2	–	–
Operating voltage range ¹⁾	[V AC]	0 ... 250	–	0 ... 250	–	0 ... 60
	[V DC]	0 ... 250	10 ... 30	0 ... 250	10 ... 30	0 ... 60
Surge capacity ¹⁾	[kV]	2.5 ²⁾	0.8	2.5	0.8	1.5
Acceptable current load at 40 °C ¹⁾	[A]	4				
Degree of contamination	3					

- 1) When different connection technologies are combined the lower value applies.
 2) 0.8 kV applies for alternative number of wires = 3.

Materials

Type	NEBU-...-P	NEBU-...-K	NEBU-...-E	NEBU-...-R
Cable characteristics	Basic	Standard	Suit. for use with energy chains	Suitable for robot applications
Housing	PUR	PUR	PUR	PUR
Union nut	Nickel-plated brass	Nickel-plated brass	Nickel-plated brass	Nickel-plated brass
Cable sheath	PVC	PUR	PUR	PUR
Pin contacts	Gold-plated brass	Gold-plated brass	Gold-plated brass	Gold-plated brass
Insulating sheath	PVC	PVC	TPE-E	TPE-E

Operating conditions

Type	NEBU-...-P	NEBU-...-K	NEBU-...-E	NEBU-...-R
Cable characteristics	Basic	Standard	Suit. for use with energy chains	Suitable for robot applications
Ambient temperature [°C]	–25 ... +70	–25 ... +70	–25 ... +80	–25 ... +80
Ambient temperature with flexible cable installation [°C]	–5 ... +80	–5 ... +70	–5 ... +80	–5 ... +80
Protection class	IP65, IP68			

Pin allocation to EN 60947-5-2

Socket M8x1						Plug M8x1					
3-pin	Pin	Wire colour	4-pin	Pin	Wire colour	3-pin	Pin	Wire colour	4-pin	Pin	Wire colour
	1	Brown		1	Brown		1	Brown		1	Brown
	3	Blue		2	White		3	Blue		2	White
	4	Black		3	Blue		4	Black		3	Blue
				4	Black					4	Black

Socket M12x1			4-pin			5-pin		
3-pin	Pin	Wire colour	4-pin	Pin	Wire colour	5-pin	Pin	Wire colour
	1	Brown		1	Brown		1	Brown
	3	Blue		2	White		2	White
	4	Black		3	Blue		3	Blue
				4	Black		4	Black
							5	Grey

Plug M12x1			4-pin			5-pin		
3-pin	Pin	Wire colour	4-pin	Pin	Wire colour	5-pin	Pin	Wire colour
	1	Brown		1	Brown		1	Brown
	3	Blue		2	White		2	White
	4	Black		3	Blue		3	Blue
				4	Black		4	Black
							5	Grey

Pin allocation – Display L

Socket M8x1			Plug M8x1			Plug M12x1	
4-pin	Pin	Wire colour	3-pin	Pin	4-pin	2-pin	Pin
	3	Black		3			3
	4	Black		4			4

Connecting cables NEBU-LE

Order code

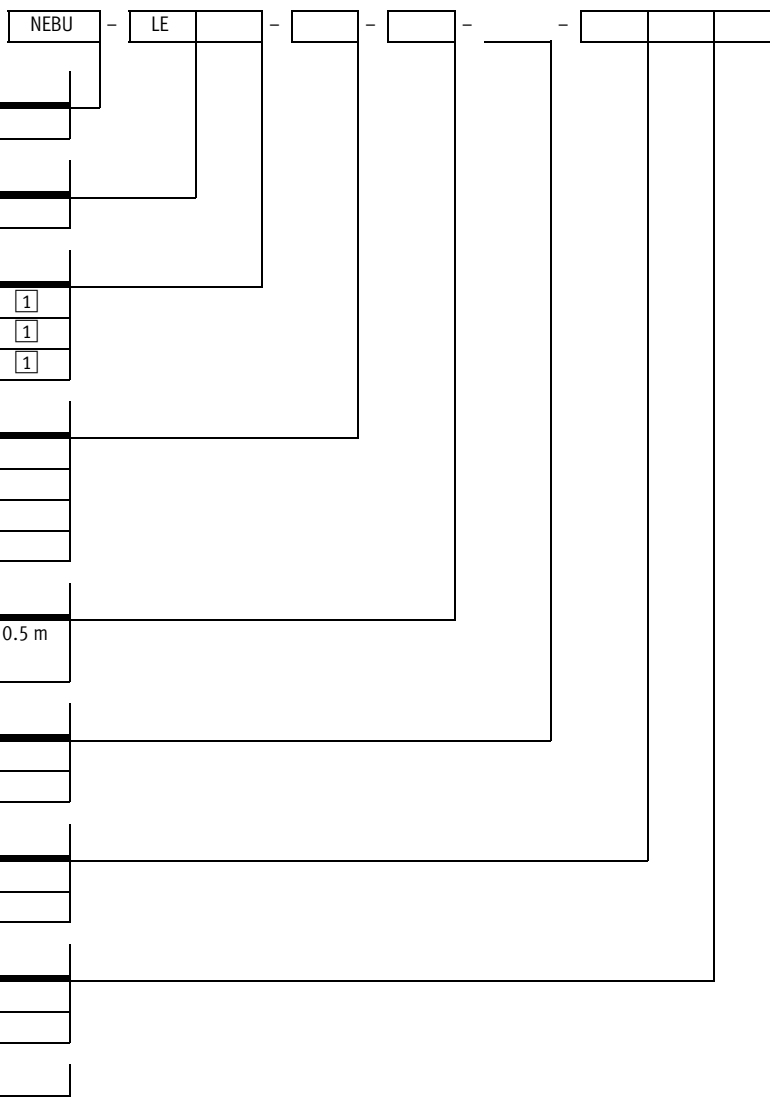

Function	
NEBU	Connecting cable

Connection technology, left-hand end	
LE	Open end

Number of pins/wires (left-hand end)	
3	3-pin (suitable for open end, plug M8) 1
4	4-pin (suitable for open end, plug M8) 1
5	5-pin (suitable for 3, 4 and 5-pin plug M12) 1

Cable characteristics	
P	Basic
K	Standard
E	Suitable for use with energy chains
R	Suitable for robot applications

Cable length	
0.1 ... 30	0.1 ... 30 m (0.1 ... 2.5 m in 0.1 m increments, 2.5 ... 30 m in 0.5 m increments)

Cable designation	
-	With inscription label holder (standard)
N	Without inscription label holder

Connection technology, right-hand end	
M8	Plug with connecting thread M8
M12	Plug with connecting thread M12, A-coded

Plug design	
G	Straight
W	Angled

Number of pins/wires (right-hand end)	
3	3-pin (suitable for socket M8/M12) 2
4	4-pin (suitable for socket M8/M12) 2
5	5-pin (suitable for socket M12) 2

1 With LE connection technology at left-hand end, the number of wires selected must be equal to the number of pins (right-hand end).

2 With LE connection technology at left-hand end, the number of wires (left-hand end) must be copied over.

Order code

NEBU - M8 - - - - -	
Function	
NEBU	Connecting cable
Connection technology, left-hand end	
M8	Socket with connecting thread M8
Socket design	
G	Straight
W	Angled
Number of pins/wires (left-hand end)	
3	3-pin (suitable for open end, plug M8)
4	4-pin (suitable for open end, plug M8)
Display	
-	Without LED, DC (standard)
P	LED, PNP 1
N	LED, NPN 1
L	LED, DC 2
Cable characteristics	
P	Basic
K	Standard
E	Suitable for use with energy chains
R	Suitable for robot applications
Cable length	
0.1 ... 30	0.1 ... 30 m (0.1 ... 2.5 m in 0.1 m increments, 2.5 ... 30 m in 0.5 m increments)
Cable designation	
-	With inscription label holder (standard)
N	Without inscription label holder
Connection technology, right-hand end	
LE	Open end
M8	Plug with connecting thread M8
M12	Plug with connecting thread M12, A-coded
Plug design	
-	Open end 3
G	Straight 4
W	Angled 4
Number of pins/wires (right-hand end)	
2	2-pin 5
3	3-pin (suitable for socket M8/M12)
4	4-pin (suitable for socket M8/M12)

- 1 Can only be combined with socket design W and 3 pins/wires (left-hand end).
- 2 Can only be combined with 4 pins/wires (left-hand end), M8 connection technology at right-hand end with 3, 4 pins/wires (right-hand end) or with LE, M12 connection technology at right-hand end with 2 pins/wires (right-hand end) (always a 2-wire cable), cable characteristics K.

- 3 Must be selected with LE connection technology at right-hand end.
- 4 Must be selected with M8, M12 connection technology at right-hand end.
- 5 Can only be combined with LE connection technology at right-hand end. Cannot be combined with cable characteristics P, E, R.

Connecting cables NEBU-M12

Order code

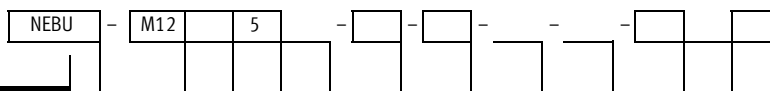

Function	
NEBU	Connecting cable
Connection technology, left-hand end	
M12	Socket with connecting thread M12, A-coded
Socket design	
G	Straight
W	Angled
Number of pins/wires (left-hand end)	
5	5-pin
Display	
-	Without LED, DC (standard)
P	LED, PNP 1
N	LED, NPN 1
P2	2x LED, PNP 2
Cable characteristics	
P	Basic
K	Standard
E	Suitable for use with energy chains
R	Suitable for robot applications
Cable length	
0.1 ... 30	0.1 ... 30 m (0.1 ... 2.5 m in 0.1 m increments, 2.5 ... 30 m in 0.5 m increments)
Cable designation	
-	With inscription label holder (standard)
N	Without inscription label holder
Wire cross section	
-	0.25 mm ² (standard)
Q8N	1 mm ² 3
Connection technology, right-hand end	
LE	Open end
M8	Plug with connecting thread
M12	Plug with connecting thread, A-coded
Plug design	
-	Open end 4
G	Straight 5
W	Angled 5
Number of pins/wires (right-hand end)	
3	3-pin (suitable for socket M8/M12) 6
4	4-pin (suitable for socket M8/M12) 6
5	5-pin (suitable for socket M12) 6

- 1 Can only be combined with socket design W and 5 pins/wires (left-hand end) and 3 pins/wires (right-hand end).
- 2 Can only be combined with socket design W and 4 pins/wires (right-hand end).
- 3 Can only be combined with M12 connection technology at left-hand end and socket design G with 5 pins/wires, M12 connection technology at right-hand end and socket design G with 5 pins/wires, cable characteristics E.

- 4 Must be selected with LE connection technology at right-hand end.
- 5 Must be selected with M8, M12 connection technology at right-hand end.
- 6 With LE open end at right-hand end, the number of pins/wires must be less than or equal to the number of pins on the opposite side.

Ordering – Product options

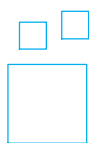

Configurable product

This product and all its options can be ordered using the configurator.

The configurator can be found under Products on the DVD or

→ www.festo.com/catalogue/...

Enter the type code in the search field.

★ Quick ordering



	Cable length [m]	Part No.	Type
Straight socket, 3-pin, M8			
Open cable end, 3-wire	2.5	541333	NEBU-M8G3-K-2.5-LE3
	5	541334	NEBU-M8G3-K-5-LE3
	10	541332	NEBU-M8G3-K-10-LE3
Straight plug, 3-pin, M8	0.5	541346	NEBU-M8G3-K-0.5-M8G3
	1	541347	NEBU-M8G3-K-1-M8G3
	2.5	541348	NEBU-M8G3-K-2.5-M8G3
	5	541349	NEBU-M8G3-K-5-M8G3
Angled socket, 3-pin, M8			
Open cable end	2.5	541338	NEBU-M8W3-K-2.5-LE3
	5	541341	NEBU-M8W3-K-5-LE3
	10	541335	NEBU-M8W3-K-10-LE3

	Cable length [m]	Part No.	Type
Angled socket, 3-pin, M8			
Open cable end, for NPN N/O contact	2.5	541336	NEBU-M8W3N-K-2.5-LE3
	5	541339	NEBU-M8W3N-K-5-LE3
Open cable end, for PNP N/O contact	2.5	541337	NEBU-M8W3P-K-2.5-LE3
	5	541340	NEBU-M8W3P-K-5-LE3

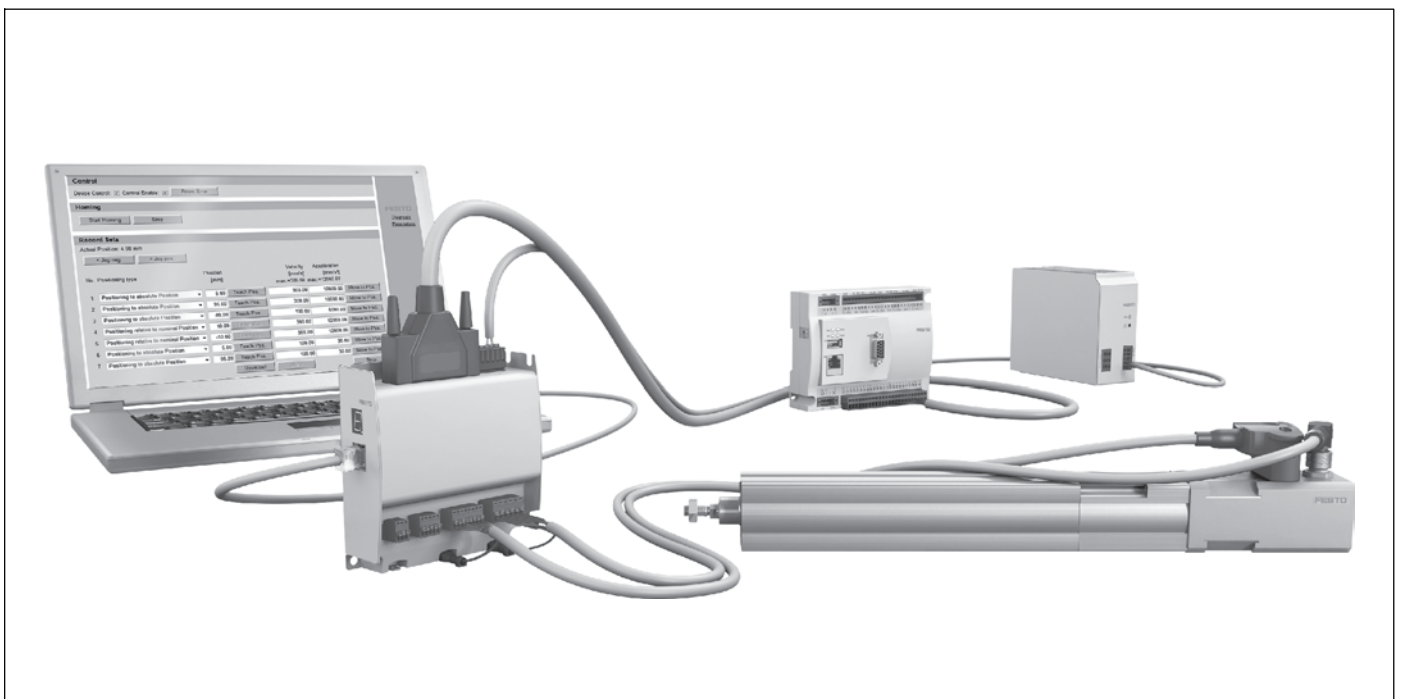
15 Control technology and software





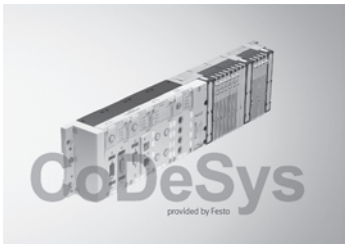

Pneumatic and electro-pneumatic controllers

Type	 Pulse oscillator TAA, TAB	 Memory module SBA-2N	 Pulse oscillator VLG
Pneumatic connection	Barbed connections for 3 mm plastic tubing	Barbed connections for 3 mm plastic tubing	G1/8, G1/4
Type of mounting	On mounting frame	On mounting frame	Through-hole in housing
Nominal size	2 mm	3 mm	3.5 mm, 7 mm
Standard nominal flow rate	60 l/min	70 l/min	120 l/min, 600 l/min
Description	<ul style="list-style-type: none"> For ensuring a logical program sequence Poppet valve with integrated AND as well as OR gate 	<ul style="list-style-type: none"> For input logic operations For simplifying the design and installation of pneumatic controllers 	<ul style="list-style-type: none"> For generating infinitely adjustable signals in controllers For high-speed cylinder movements with single and double-acting diaphragm cylinders
→ Page/online	taa	sba	vlg





Software tool

CoDeSys		<p>CoDeSys for standardised programming of embedded devices to IEC 61131-3. It makes your life easier with simple commissioning, fast programming and parameterisation.</p> <p>Advantages</p> <ul style="list-style-type: none"> Hardware-neutral software platform for quick and easy configuration, programming and commissioning of pneumatic and electrical automation solutions Extensive module libraries for single or multi-axis positioning motions 	<ul style="list-style-type: none"> The IEC 61131-3 standard means that CoDeSys is flexible and open for all types of control tasks Modular: offline and online functions as well as components for hardware configuration and visualisation User-friendly IEC function block extension Re-use of existing application parts <p>The CoDeSys parameterisation software can be found on the website under Support > Support Portal > enter search term.</p>
---------	--	---	--





Electronic controllers

Type	 Controller CECC-D, CEDD-LK	 Controller FED-CEC	 Controller FED-CECCAN	 Controller CECX-X-M1
Operating voltage	19.2 ... 30 V DC	18 ... 30 V	18 ... 30 V	19.2 ... 30 V DC
CPU data	400 MHz processor	32-bit RISC processor, 24 MHz, watchdog	32-bit RISC processor, 24 MHz, watchdog	64 MB DRAM, 400 MHz processor
Type of fieldbus interface	CAN	CAN	CAN	CAN
Ethernet, connector plug	RJ45	RJ45	RJ45	RJ45
Description	<ul style="list-style-type: none"> Modern, compact and versatile controller Programming with CoDeSys to IEC 61131-3 12 digital inputs, 8 digital outputs, additionally 2 high-speed counters up to 250 kHz Ethernet 10/100 Mbit/s USB interface for transferring data CECC-LK with CANopen, IO-Link, I-Port and Modbus TCP protocol 	<ul style="list-style-type: none"> Ethernet transmission speed 10 Mbps Plug-in card with processor module For installation in the operator units FED-50 ... FED-5000 Fieldbus interfaces CANopen CoDeSys programming software 	<ul style="list-style-type: none"> Ethernet transmission speed 10/100 Mbps Plug-in card with processor module For installation in the operator units FED-400, FED-550, FED-700, FED-1000, FED-2000, FED-5000 Fieldbus interfaces CANopen CoDeSys programming software 	<ul style="list-style-type: none"> Motion controller with CoDeSys and SoftMotion Programming to standard IEC 61131-3 Three plug-in slots for optional modules Optional: communication module for PROFIBUS
→ Page/online	964	fed-cec	fed-ceccan	cec-x-m1





Electronic controllers

				
Type	Controller CECX-X-C1	Input/output module CECX-D-E8A, CECX-A-4E4A	Input module CECX-D-16E, CECX-A-4E-V, CECX-E-E-T-P	Output module CECX-D-14A-2, CECX-A-4A-V
Operating voltage	19.2 ... 30 V DC	19.2 ... 30 V DC		24 V DC
CPU data	64 MB DRAM, 400 MHz processor			
Type of fieldbus interface	CAN			
Ethernet, connector plug	RJ45			
Description	<ul style="list-style-type: none"> Modular master controller with CoDeSys Programming to standard IEC 61131-3 Three plug-in slots for optional modules Optional: communication module for PROFIBUS 	<ul style="list-style-type: none"> Digital modules: 6 or 8 digital inputs and 8 digital outputs Analogue modules for voltage: 4 analogue voltage inputs and 4 analogue voltage outputs Analogue modules for current: 4 analogue current inputs and 4 analogue current outputs Address setting function, short circuit monitoring function for outputs, debounce function, interrupt function, sensor failure detection function 	<ul style="list-style-type: none"> Digital modules: 16 digital inputs Analogue modules for voltage: 4 analogue voltage inputs Temperature input modules: 4 or 6 temperature inputs 	<ul style="list-style-type: none"> Digital modules: 14 digital outputs Analogue modules: 4 analogue voltage outputs
→ Page/online	cecx-x-c1	cecx	cecx	cecx





Electronic controllers

				
Type	Encoder interface CECX-C-2G	Fieldbus interface CECX-F-PB-S-V, CECX-F-PB-V1, CECX-B-CO	Electrical interface CECX-C-2S1	AS-i module CESA
Operating voltage	19.2 ... 30 V DC			30 V DC
CPU data				
Type of fieldbus interface		CAN Bus, PROFIBUS master DP-V1, PROFIBUS slave DP-V0, PROFIBUS slave DP-V1		CANopen, PROFIBUS
Ethernet, connector plug	9-pin, socket, RJ45	8-pin, socket, 9-pin, plug	9-pin, plug	
Description	<ul style="list-style-type: none"> Distance measurement function Pulse counter Speed measurement function Shaft encoder monitoring function Counter reading latch function Sensor break monitoring Status indication function 	<ul style="list-style-type: none"> PROFIBUS master DP-V1 Connection via CAN Bus to the modular controller For connecting decentralised peripheral modules in series 	<ul style="list-style-type: none"> For extending the controller with two RS232 serial interfaces 	<ul style="list-style-type: none"> AS-i master gateway Duplicate address recognition Direct operation Graphical display Comprehensive diagnostics via LED and display Specification 3.0
→ Page/online	cecx	cecx	cecx	cesa



Electrical peripherals

Type	 Terminal CPX-P	 Installation system CTEL	 Fieldbus module CTEU	 Input module CTSL
Max. no. of inputs	64	64	128	16
Max. no. of outputs	64	64	128	
No. of module positions	Max. 9 electric		32	
Electrical actuation	Fieldbus, integrated controller	CANopen, DeviceNet, CC-Link, PROFIBUS, EtherCAT	CANopen, DeviceNet, CC-Link, PROFIBUS, EtherCAT, I-Port	IO-Link, I-Port
Description	<ul style="list-style-type: none"> Use of harmonised remote I/O and valve terminals in a control cabinet Unique modular design Comprehensive integrated diagnostic and maintenance function Combination with modules of the electrical terminal CPX, which enables use for hybrid applications IP65 	<ul style="list-style-type: none"> Installation system with components for integrating decentralised modules in the CPX automation platform Ideal for creating subsystems CTEU fieldbus modules for universal use of valve terminals Festo-specific interface (I-Port) enables the use of bus modules for different valve terminal types Input modules CTSL for recording sensor signals Costs savings in the case of valve terminals with a large number of valves on the fieldbus thank to reduction of hardware Direct and simple networking of valve terminals and other devices via a fieldbus High protection class IP65/67 	<ul style="list-style-type: none"> For valve terminals VTUB-12, VTUG, MPA-L, CPV, VTOC Versatility thanks to high protection class IP65/67 Fieldbus-typical LEDs, interfaces and switching elements available Isolated power supply for electronics and valves Optional basic diagnostics: undervoltage, short circuit Optionally expandable for low-cost, decentralised installation of two additional valve terminals with I-Port 	<ul style="list-style-type: none"> For installation system CTEL For recording sensor input signals Display of the input statuses for each input signal via an assigned LED Diagnostic LED for short circuit/ overload in sensor supply
→ Page/online	968	ctel	cteu	ctsl



Electrical peripherals

Type	 CPI installation system CTEC	 Terminal CPX	 Electrical interface CPX-CTEL	 AS-Interface® components ASI
Max. no. of inputs	128	Digital 512, analogue 32	256	496
Max. no. of outputs	128	Digital 512, analogue 18	256	496
No. of module positions	Max. 4 installation strings, max. 4 CP modules per string	Max. 9 electric input/output modules	Max. 4 modules with I-Port interface	
Electrical actuation	Fieldbus, integrated controller	Fieldbus, integrated controller	I-Port	AS-Interface
Description	<ul style="list-style-type: none"> Complete concept for decentralised machine and system structure Combination of centralised and decentralised installation possible in combination with terminal CPX Decentralised pneumatic components and sensors for fast processes Centralised electrical components for fieldbus and common power supply With valve terminal CPV, MPA, CPV-SC 	<ul style="list-style-type: none"> Centralised, decentralised, hybrid installation system with maximum modularity and flexibility IP65 and IP67 or IP20 Choice of plastic or metal housing with individual linking Open to common fieldbus protocols and Ethernet Integrated diagnostic and service function Operating modes: stand-alone, as remote I/O or with valve terminals MPA-S, MPA-F, MPA-L, VTSA/VTSA-F 	<ul style="list-style-type: none"> Cost-effective: fieldbus connection for the price of a multi-pin interface Decentralised input modules and valve terminals with short tubing, short cycle times and low energy consumption in combination with terminal CPX Standardised M12 connections reduce cost, installation time and logistical complexity 	<ul style="list-style-type: none"> Accessories for AS-Interface Installation system Modules for actuating individual valves ASI-EVA Cable distributor ASI-KVT Addressing device ASI-PRG-ADR Compact I/O modules (IP65, IP67) AS-Interface power supply unit SVG
→ Page/online	ctec	cpx	cpx-ctel	as-interface



Operator units, text-based

		
Type	Operator unit FED-40, FED-50, FED-60, FED-90	Operator unit CPX-MMI
Display	Monochrome LCD, with backlighting	128 x 64 pixels, LCD display, with backlighting
Display size	4 x 20 characters	
Recipe memory	16 KB	
Ethernet interface	Optional, 10 MBd	
No. of user LEDs	5 ... 13	
No. of function keys	4 ... 12	
Description	<ul style="list-style-type: none"> • Straightforward designing of human-machine dialogues • Semi-graphical display of process values makes them easier to read • 4-line text display and operating buttons • Serial interface • Recipe handling • Password protection 	<ul style="list-style-type: none"> • Data retrieval from, configuration of and diagnostics of terminal CPX • 3 function keys, 4 arrow keys • Connection to the CPX bus nodes or control block using a pre-assembled M12 cable
→ Page/online	fed	cpx-mmi

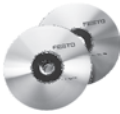
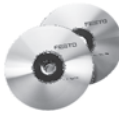

Operator units, with touchscreen

			
Type	Operator unit CDSA	Operator unit FED-301, FED-400, FED-501, FED-550, FED-700, FED-770, FED-1000, FED-2000, FED-3000, FED-5000	Operator unit CDPX
Display	Colour TFT	Monochrome LCD, TFT colour	Colour TFT
Display size	6.5"	3.8", 4.3", 5.6", 5.7", 7", 7.5", 10.4", 12.1", 13.3", 15"	4.3", 7", 10.4", 13.3"
Recipe memory		1/4 VGA, 320x240 pixels, 480x272 pixels, SVGA, 800x600 pixels, VGA, 640x480 pixels, WVGA, 800x480 pixels, WXGA, 1280x800 pixels, XGA, 1024x768 pixels	WQVGA 480x272 pixels, WVGA, 800x480 pixels, SVGA, 800x600 pixels, WXGA, 1280x800 pixels
Ethernet interface	2nd Ethernet interface optional 10 MBd, RJ45 10/100 MBd	100 MBd, 2nd Ethernet interface optional 10 MBd, RJ45 10/100 MBd, optional, 10 MBd	RJ45 10/100 MBd
No. of function keys	31		
Description	<ul style="list-style-type: none"> • Interfaces for Ethernet, RS-422-A/RS-232-C, USB host/USB client • Designs with colour touchscreen 	<ul style="list-style-type: none"> • Graphics-capable for maximum flexibility when displaying processes and data • No programming effort in the PLC program • Convenient FED Designer WYSIWYG design tool • Shorter project planning thanks to re-usable objects • Trend display • Program sequences display • Can be connected to all FEC® units • Extremely sturdy thanks to metal housing 	<ul style="list-style-type: none"> • Powerful processors combined with wide screen technology • Remote access, remote control • FTP and HTTP servers • Open for web and multimedia applications
→ Page/online	cdsa	fed	cdpx

Software

Type	 Operator package GSIB	 Operator package P.BP	 Software GSPF	 Software and manual P.SW
Description	<ul style="list-style-type: none"> Information software and documentation for motor controller CMMD-AS, CMMS-AS, CMMP-AS, CMMS-ST Operator package contains CD-ROM with user documentation for motor controller and FCT (Festo Configuration Tool) configuration software and brief description 	<ul style="list-style-type: none"> Information software and documentation for motor controller CMMP-AS and SFC-DC, handling module HSP/HSW and motor unit MTC-DCI Operator package contains CD-ROM with user documentation for motor controller and FCT (Festo Configuration Tool) configuration software and brief description 	<ul style="list-style-type: none"> Programming software and documentation for motor controller CMMP-AS with additional functions for cam disc functionality Software for configuring, programming, commissioning and maintaining the controller CECC Programming software for creating custom application programs for safety systems CMGA Operating software for configuring, programming and for AS-Interface diagnostics using serial connecting cable Software package contains CD-ROM with user documentation for motor controller 	<ul style="list-style-type: none"> For configuring the terminal CPX, for parameterising the CPX modules, for programming the controller CPX-FEC Software for Checkbox CHB-C for image evaluation, display, protocol and adaptation of the I/O parameters Software for Checkbox CHB-C for complete analysis of the recognition processes
→ Page/online	gsib	software	gspf	software

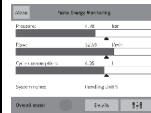
Software

Type	 Software licence GSLO	 Diagnostic module GFDM	 Software (FluidDraw S5®) GSWF-S5	 Software (FluidDraw P5®) GSWF-P5
Description	<ul style="list-style-type: none"> For activating tools on the compact vision system SBOC-Q/SBOI-Q 	<ul style="list-style-type: none"> Diagnostic system for continuous monitoring of the pressure, flow and cyclical consumption of a pneumatic system The system includes sensors (a flow sensor and a pressure sensor) for recording the measured values, a controller for evaluation and one of two visualisation options Limit monitoring and information about trends Automatic reference data acquisition (teach-in) Monitoring of up to 16 different process sequences on one system 	<ul style="list-style-type: none"> Quick and easy creation of pneumatic circuit diagrams Extensive library of pneumatic symbols Easy, user-friendly operator guidance Interface to Festo products (catalogue, online shop) 	<ul style="list-style-type: none"> Quick and easy creation of pneumatic circuit diagrams Comprehensive library of pneumatic and electrical symbols User-specific product databases and translation tables Terminal plans, cable diagrams, cable lists, parts lists Dimensioning function for preparing simple control cabinet and system layouts Consistent equipment identification Multi-level project tree
→ Page/online	gslo	gfdm	gswf-s5	gswf-p5

Documentation

	
Type	Manuals GDCW, GDCP, GDCC, GSIB, P.BE, P.BP
Description	<ul style="list-style-type: none"> • For software • For control blocks • For motors and controllers • For valve terminals and electrical peripherals • For vision systems
→ Page/online	documentation

Learning systems

	
Type	EduTrainer® D
Description	<ul style="list-style-type: none"> • PLC EduTrainer® support system for use in teaching and training • Equipped with PLCs from different manufacturers • Two series: Universal and Compact • Equipped with 19" simulation modules • Individually configurable or pre-assembled
→ Page/online	edutrain



- Compact controller with 400 Mhz processor
- CoDeSys provided by Festo
- 12 digital inputs
- 8 digital outputs
- ★ Quick ordering of basic designs → 966

→ www.festo.com/catalogue/cecc

Application

Controller



The controllers CECC are modern, compact and versatile controllers that enable programming with CoDeSys according to IEC 61131-3.

State-of-the-art programming

CoDeSys V3 pbF offers a user-friendly interface with the following new functions:

- Object-oriented programming
- Modern editors for simplified input
- Simplified configuration for fieldbus

- New configurator for IO-Link masters

IO-Link

- Multiple controllers in one project
- Improved troubleshooting function
- Simplified project navigation

Basic functions of the CECC-D

The controllers CECC (CECC-D) offer the following basic functions:

- 12 digital inputs, 8 digital outputs, additionally 2 high-speed counters up to 250 kHz
- Ethernet 10/100Mbit/s, Modbus TCP client/server, EasyIP, TCP/IP, OPC server available

- CANopen master: connection of the electric drives
- USB interface for data transfer
- Can be connected directly with modern HMI devices: CDPX

Basic functions of the CECC-LK

- This variant of the CECC offers four IO-Link masters and one IO-Link device interface
- The integrated IO-Link interface of the CECC-LK enables quick and easy connection of Festo valve terminals and sensors to a controller

- All modern, compact valve terminals from the CTEU series can be connected to IO-Link masters: VTUB, VTUG, MPA, CPV, VTOC and upcoming devices, as well as the input box CTSL

Fieldbus interfaces

The CECC-LK can be connected to a combination of node CTEU and CAPC on various fieldbuses via the IO-Link device interface:

- PROFIBUS
- EtherCAT
- DeviceNet
- CANopen
- AS-interface



System configuration

The CECC can communicate with all electric drive controllers from Festo and actuate all valve terminals via CANopen.

The CECC communicates with other controllers and operator units from Festo via Ethernet, such as the modern, new HMI device series CDPX and the camera SBOX-Q for image evaluation.

Technical data



Technical data	
CPU data	400 MHz processor
Status displays	LED
Electrical connection technology for I/O	Socket strip, 3.5 mm grid
Protection class	IP20

Digital inputs	
Number	12
Switching logic	Positive logic (PNP)
High-speed clock pulse inputs	2, each with max. 200 kHz
Input signal delay [ms]	Typically 3
Input voltage [V DC]	24
Permissible connecting cable length [m]	30

Digital outputs	
Number	8
Switching logic	Positive logic (PNP)
Contact	Transistor
Output voltage [V DC]	24
Output current [mA]	500
Switching frequency [kHz]	Max. 1
Protection against short circuit	Yes

Serial interfaces	
USB interface	USB 1.1 for connecting external storage media
Ethernet interface	RJ45 for connecting external operator units
IO-Link interface	Cage Clamp, master 5-pin
Fieldbus interface	
Programming software	CoDeSys provided by Festo
Fieldbus interface type	CAN bus, master
Connection technology	Sub-D plug, 9-pin
Transmission rate [kbps]	125; 250; 500; 800; 1,000
	Adjustable via software

Operating and environmental conditions	
Operating voltage [V DC]	19.2 ... 30
Current consumption at 24 V DC [mA]	100
Ambient temperature [°C]	0 ... 55

Order code

		CECC	–	LK
Type				
CECC				
Function module				
LK	IO-Link			
D	–			

Ordering – Product options

Configurable product

This product and all its options can be ordered using the configurator.

The configurator can be found under Products on the DVD or
[→ www.festo.com/catalogue/...](http://www.festo.com/catalogue/...)

Enter the type code in the search field.

★ Quick ordering

	Part No.	Type		Part No.	Type
With IO-Link master	574418	CECC-LK		574415	CECC-D
			Without IO-Link master		

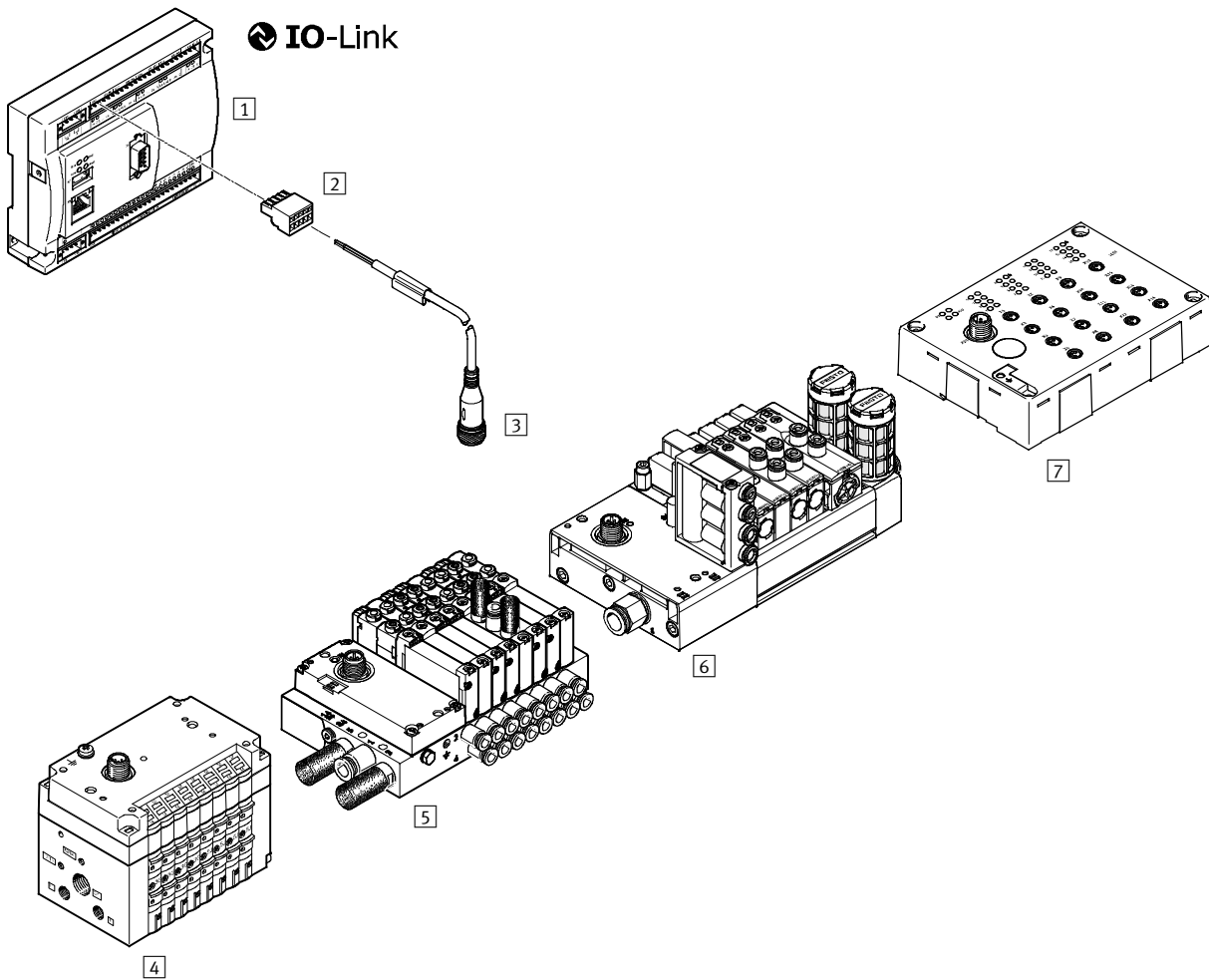

Accessories



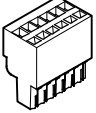

Mounting components and accessories		→ Page/ online
1	Controller CECC	966
2	Plug NECC	967
3	Connecting cable NEBU	967
4	Valve terminal CPV	cpv

Mounting components and accessories		→ Page/ online
5	Valve terminal VTUG	vtug
6	Valve terminal VTUB	vtub
7	Input module CTSL	ctsl
–	CoDeSys V3 software	967

Accessories – Ordering data

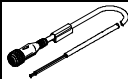
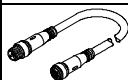
	Description	Part No.	Type
2 Plug			
	–	575303	NECC-L2G4-C1-M
	2-pin	575302	NECC-L2G2-C1
	5-pin	575304	NECC-L2G5-C1
	6-pin	575305	NECC-L2G6-C1
	8-pin	575306	NECC-L2G8-C1
	24-pin	575307	NECC-L2G24-C1
	9-pin	576031	NECC-S1G9-C2-M

	Description	Part No.	Type
3 Connecting cables			
Technical data → 949			
	Up to 5 m can be used	539052	NEBU-M12W5-P-2-N-LE5
	Up to 20 m can be used ¹⁾	574321	NEBU-M12G5-E-5-Q8-M12G5
		574322	NEBU-M12G5-E-7,5-Q8-M12G5
		574323	NEBU-M12G5-E-10-Q8-M12G5
Programming software			
	–	542000	GSPF-CDS-3

1) Modular product, more information → Internet:nebu

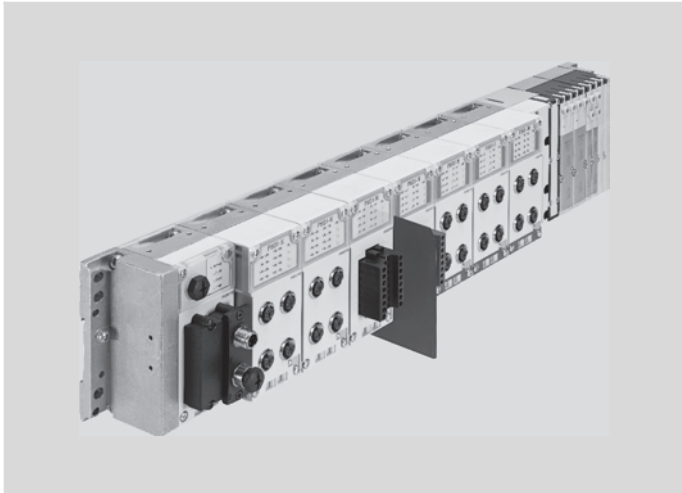

- Use of harmonised remote I/O and valve terminals in a control cabinet
- Unique modular structure
- Comprehensive integrated diagnostic and maintenance functions
- Combination with modules of the electrical terminal CPX, which enables use for hybrid applications

→ www.festo.com/catalogue/cpx-p

Product range overview

Type	Designation	Code ¹⁾	Address space		→ Page/ online
			Inputs	Outputs	
CPX-FEC-1-IE	Front End Controller Remote I/O	T05	512 bit	512 bit	cpx-p
CPX-FB11	Bus node for DeviceNet	F11	512 bit	512 bit	976
CPX-FB13	Bus node for PROFIBUS DP	F13	512 bit	512 bit	976
CPX-FB32	Bus node for Ethernet/IP	F32	128 bit	128 bit	977
CPX-FB33	Bus node for PROFINET RT, 2 x M12	F33	512 bit	512 bit	977
CPX-P-8DE-N-IS	Input module, 8 digital inputs to NAMUR, intrinsically safe	BW	16 bit ²⁾	8 bit ²⁾	978
CPX-P-8DE-N	Input module, 8 digital inputs to NAMUR	BR	16 bit ²⁾	8 bit ²⁾	978
CPX-16DE	Input module, 16 digital inputs	M	16 bit	–	979
CPX-4DA	Output module, 4 digital outputs	A	–	4/8 bit ³⁾	979
CPX-8DA	Output module, 8 digital outputs	L	–	8 bit	cpx-p
CPX-4AE-U-I	Input module, 4 analogue inputs	NI	64 bit	–	cpx-p
CPX-2AA-U-I	Output module, 2 analogue outputs	P	–	32 bit	980
VMPA-FB-EPLM	Pneumatic interface to MPA-S	–D	16 ... 512 bit	4 ... 512 bit	982

- 1) Code letter within the order code for a valve terminal configuration
 2) If the inputs are configured as counters, an address space of 80-bit inputs and 16-bit outputs is required
 3) Number of occupied bits is dependent on the upstream bus node/control block

Note

The electrical terminal can be ordered quickly and easily online.
 The convenient product configurator can be found at:

→ www.festo.com/catalogue/cpx-p

Note

- The bus node and control block provide the aforementioned address space.
- Input/output modules, etc. use the specified address space.

Key features

Installation concept

- Economical from the smallest configuration up to the maximum number of modules
- Up to 9 electrical input/output modules plus bus nodes and pneumatic interface/electronics modules for valves
- Extensive range of functions and connection options for the electrical modules
- Choice of connection technology for technically and economically optimised connections
- Can be used as a dedicated remote I/O module

Electrics

- High operating voltage tolerance ($\pm 25\%$)
- Open to all fieldbus protocols and Ethernet
- IT services and TCP/IP such as remote maintenance, remote diagnostics, web server, SMS and e-mail alert
- Digital inputs and outputs, 4-way/8-way/16-way, optionally available with individual channel diagnostics
- Analogue inputs and outputs, 2-way/4-way
- Input modules for connecting NAMUR sensors
- IP65 or IP20

Mounting

- Wall or H-rail mounting, also on mobile units
- Conversions/extensions are possible at any time, individual linking
- Modular system offering a range of configuration options
- Fully assembled and tested unit
- Lower costs for selection, ordering, assembly and commissioning thanks to the central CPX-P terminal
- Choice of pneumatic components for optimised control loop system design

Operation

- Fast troubleshooting thanks to an extensive selection of LEDs (some of which are multi-coloured) on the bus node and on all I/O modules
- Supports module and channel-oriented diagnostics
- On-the-spot diagnostics in plain text via operator unit (CPX-MMI)
- Fieldbus/Ethernet remote diagnostics
- Innovative diagnostic support with integrated web server/web monitor or maintenance tool (CPX-FMT) with USB adapter (NEFC) for PC
- Optimised commissioning thanks to parameterisable functions
- Reliability of service with connection blocks and modules that are quick to replace without changing the wiring

CPX modules for NAMUR sensors, intrinsically safe circuits for ATEX applications

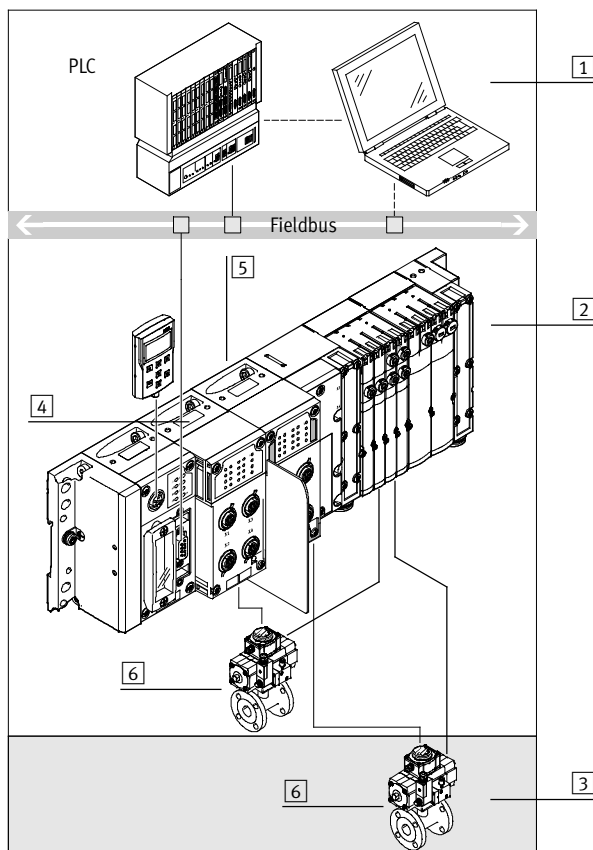

- 1 Higher-order controller
- 2 Non-ATEX zone; non-intrinsically safe circuits are permitted
- 3 ATEX zone; only intrinsically safe circuits are permitted
- 4 CPX input module for NAMUR sensors, non-intrinsically safe design
- 5 CPX input module for NAMUR sensors, intrinsically safe design
- 6 Actuator/machine component with NAMUR sensors

CPX-P modules are suitable for configuring intrinsically safe or non-intrinsically safe circuits depending on the design selected.

This enables components from both safe and hazardous zones to be connected to the CPX-P terminal. The components for the intrinsically safe zone are marked in blue or entirely coloured blue to distinguish them visually.

Note

Intrinsically safe circuits are circuits which release so little energy during operation, or in the event of certain faults under specified test conditions, that no ignition can occur in a particular potentially explosive atmosphere.

Variants

Complete overview of modules

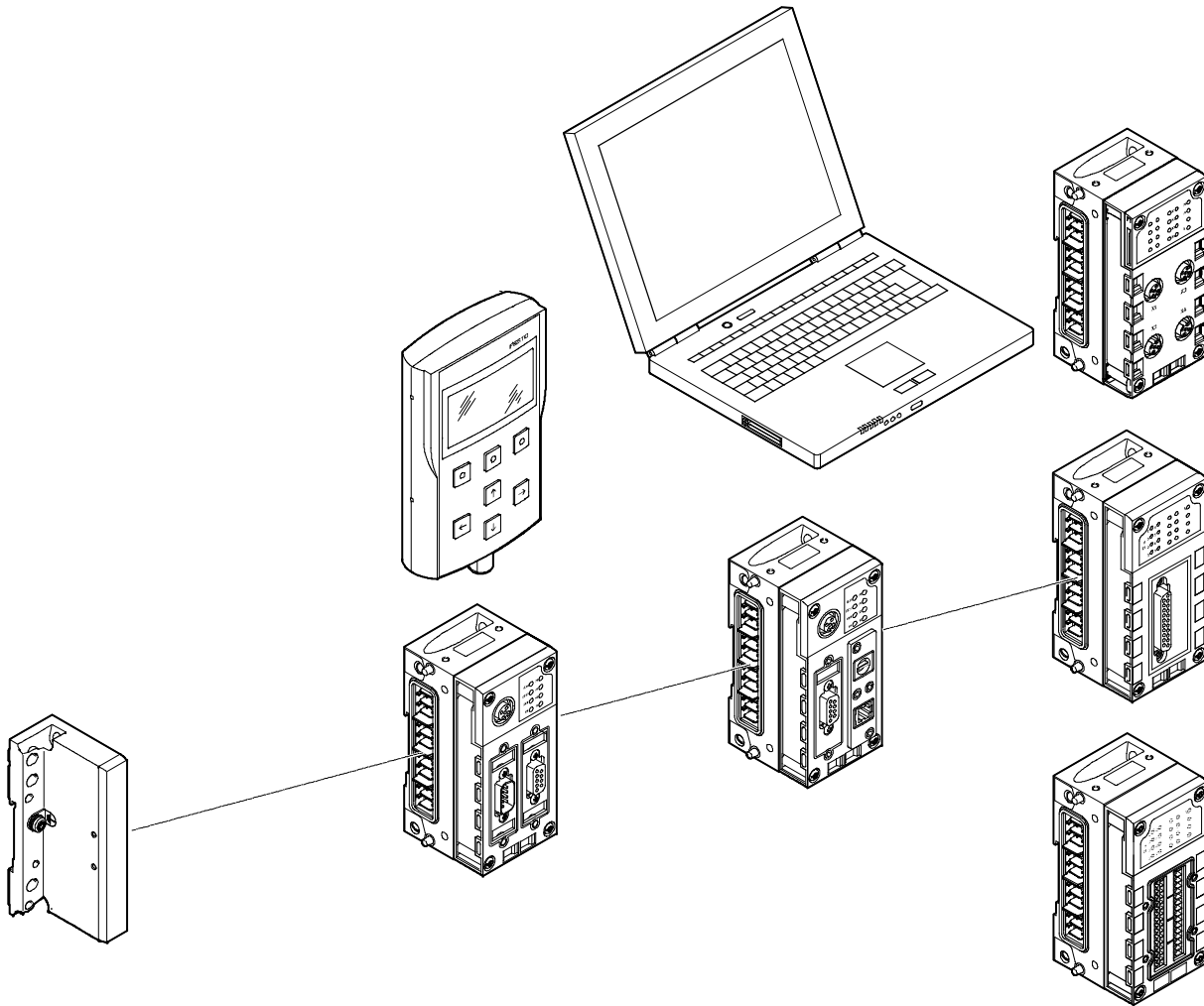
**End plate**

- Mounting holes for wall mounting
- Functional earth connection

Bus node

- Fieldbus/Industrial Ethernet connection using various types of connection technology
- Setting of fieldbus parameters via DIL switch
- Display of fieldbus and peripheral equipment status via LED

Operator unit

- Connection to bus nodes or control block
- Display and modification of parameter settings
- Plain-text display for texts, messages (e.g. individual channel diagnostics, condition monitoring), menus, etc.

Control block

- Remote unit CPX-FEC-1-IE
- Connection via Ethernet TCP/IP or Sub-D programming interface
- Setting of operating modes via DIL switch and program selection via rotary switch

Input/output modules

Combination of

- Interlinking block
- Electronics module
- Connection block

Variants

Complete overview of modules

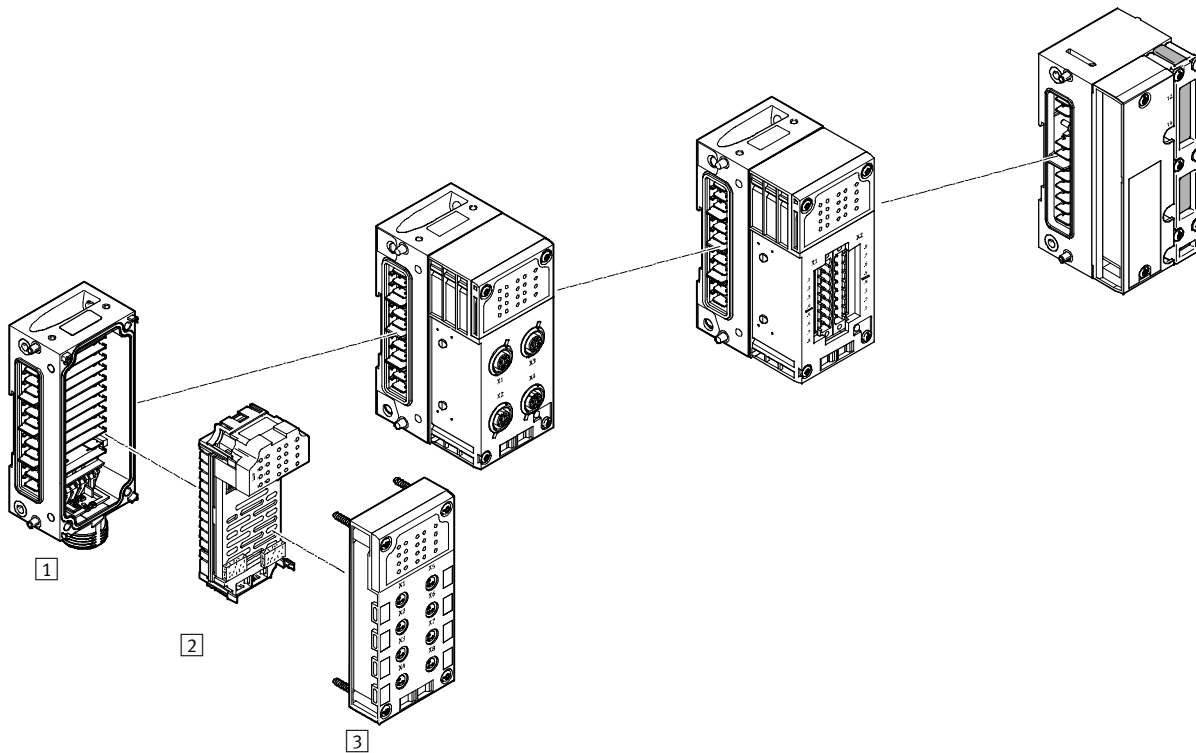

Input/output modules

1 Interlinking block

- Internal linking of the power supply and serial communication
- External power supply for the entire system
- Additional power supply for outputs
- Connection accessories for 7/8"
- Individual linking with M6 screws, individually expandable

2 Electronics module

- Digital inputs for connecting the sensors
- Digital outputs for activating additional actuators
- Analogue inputs
- Analogue outputs

3 Connection block

- Choice of connection technology
- Protection class IP65 or IP20
- Can be combined with the electronics modules
- Connection accessories for M8/M12/Sub-D/quick connection, etc.
- M8/M12/Sub-D, etc. connecting cables
- Modular system for connecting cables

Pneumatic interface

- Actuation of the solenoid coils
- MPA-S
- Actuation of pressure sensors
- Actuation of proportional pressure regulators

Terminal CPX-P

Variants

Individual overview of modules

Bus node

Technical data → 977 ff.

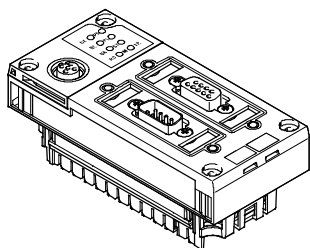

- Bus node for
- PROFIBUS DP
 - DeviceNet
 - Ethernet/IP (integrated web server)
 - PROFINET (integrated web server)

Plastic connection block

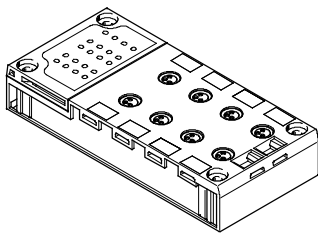

- Direct machine mounting (protection class IP65/IP67)
- M8 3-pin or 4-pin
 - M12 5-pin, 5-pin with quick lock/ metal thread screened, 8-pin, optional screening plate
 - Sub-D
 - Quick connection
 - Spring-loaded terminal with protection to IP20 or with cover

Metal connection block

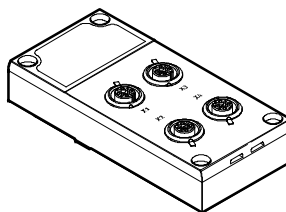

- Direct machine mounting (connection block to IP65/IP67)
- M12-5POL

Connection block for NAMUR sensors

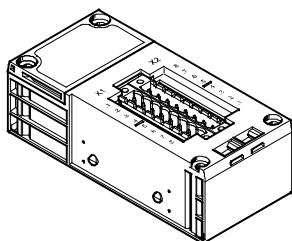

- Direct machine mounting (connection block to IP65)
- M12-4POL
- Protected fitting space (connection block to IP20)
- Screw terminal
 - Spring-loaded terminal

Module for NAMUR sensors

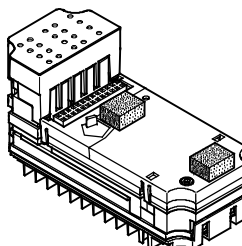

- Technical data → 978
- Digital inputs
- 8 digital inputs for NAMUR sensors or wired mechanical contacts
 - Intrinsically safe design with additional protective measures in the event of failure

Digital electronics module

Technical data → 979 ff.

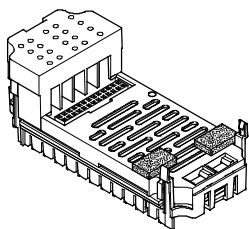

- Digital inputs
- 16 digital inputs
- Digital outputs
- 4 digital outputs (1 A per channel, individual channel diagnostics)
 - 8 digital outputs (0.5 A per channel, individual channel diagnostics)

Analogue electronics module

Technical data → 980 ff.

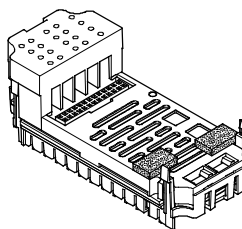

- Analogue inputs
- 4 analogue inputs (1 ... 5 V, 0 ... 10 V, -5 ... +5 V, -10 ... +10 V, 0 ... 20 mA, 4 ... 20 mA, -20 ... +20 mA)
- Analogue outputs
- 2 analogue outputs (0 ... 10 V DC, 0 ... 20 mA, 4 ... 20 mA)

Individual overview of modules

Metal interlinking block – Individual linking

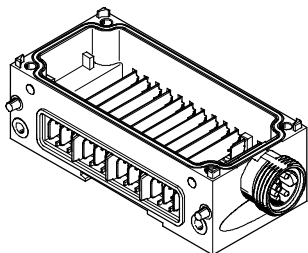

- System linking
- Different voltages for supplying the modules
 - Serial communication between the modules

- System supply
- 7/8" 5-pin

- In addition to system linking, power supply for the
- electronics plus sensors (8 A)
 - valves plus actuators (8 A)

- Additional power supply
In addition to system linking, power supply for the
- actuators (8 A per supply)

Technical data → 981 ff.

- Expandability
- Can be expanded as required by up to 10 interlinking blocks

Note
The 7/8" supply is subject to the following restriction due to the available accessories:

- 5-pin 8 A

Variants

Pneumatic interface MPA-S

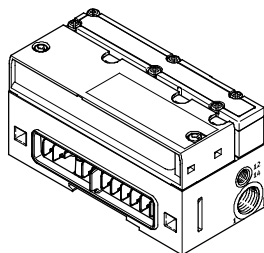

→ 982

Valve terminal

- MPA1 (360 l/min)
- MPA2 (700 l/min)
- Up to 128 solenoid coils
- Up to 16 modules can be configured

End plate

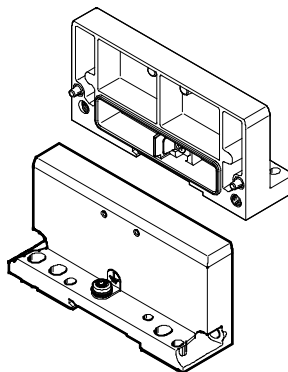

End plate

- Left-hand
- Right-hand (for use without valves)

General basic data and guidelines

Max. 11 modules in total:

- One bus node and/or one control block
- Up to 9 additional input/output modules
- An additional pneumatic interface,
 - always positioned as the last module on the right-hand side
 - 16 MPA modules can be configured

- Address capacity max. 512 inputs and 512 outputs, depending on bus node or control block
- One interlinking block with system supply
- Multiple interlinking blocks with additional power supply, always positioned to the right of the interlinking block with system supply

- The connection blocks can, with just a few exceptions, be combined with the electronics modules for inputs/outputs (→ table below)
- The electronics modules can be combined with various interlinking blocks

Technical data – Electrical terminal CPX-P

- [J] - Module width
50 mm

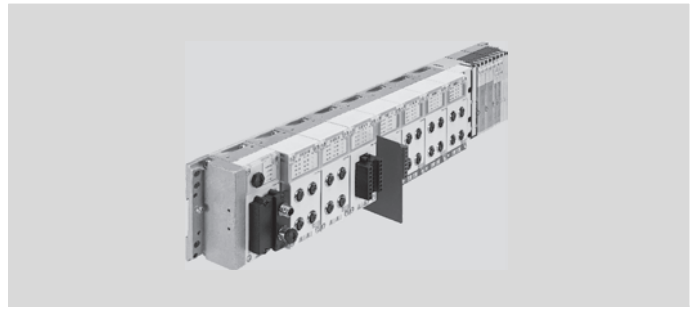

General technical data			
Max. number of modules ¹⁾	Control block		1
	Bus node		1
	I/O modules		9
	Pneumatic interface		1
Max. address capacity	Inputs/outputs	[byte]	64/64
Configuration support	Fieldbus-specific		
LED displays	Bus node/control block		Up to 4 LEDs, bus-specific 4 LEDs, CPX-P-specific PS = Power system PL = Power load SF = System fault M = Modify parameter/forcing active
		I/O modules	Min. one centralised diagnostic LED Channel-oriented status and diagnostic LED, depending on module
	Pneumatic interface		One centralised diagnostic LED Valve status LED on valve
Diagnostics	Channel and module-oriented diagnostics for inputs/outputs and valves		
	Detection of module undervoltage for the different potential values		
	Storage of the last 40 errors with timestamp (acyclic access)		
Parameterisation, module-specific and entire system, for example:	Diagnostic behaviour		
	Condition monitoring		
	Profile of inputs		
	Fail-safe response of outputs and valves		
Commissioning support	Forcing of inputs and outputs		
Protection class to EN 60529	IP20, IP65		
Tests	Vibration test to DIN IEC 68		With wall mounting: severity level 2
			With H-rail mounting: severity level 1
	Shock test to DIN IEC 68		With wall mounting: severity level 2
			With H-rail mounting: severity level 1
Resistance to interference	EN 61000-6-2 (industry)		
Emitted interference	EN 61000-6-4 (industry)		
Grid dimension		[mm]	50

1) A maximum of 11 modules in total can be combined
(e.g. 1 control block + 9 I/O modules + 1 pneumatic interface, or 1 control block + 1 bus node + 8 I/O modules + 1 pneumatic interface)

Technical data – Electrical terminal CPX-P

Download CAD data → www.festo.com

Electrical data		
Power supply	Interlinking block with system supply	
	Electronics plus sensors	[V] 24 DC, max. 8 A
	Actuators plus valves	[V] 24 DC, max. 8 A
	Additional power supply	
	Actuators	[V] 24 DC, max. 8 A per supply
Current consumption		Depending on system configuration
Power failure bridging (bus electronics only)		[ms] 10
Power supply connection		7/8" 5-pin
Fuse concept		Per module with electronic fuses
Isolation test for galvanically isolated circuits to IEC 1131 Part 2		[V] 500 DC
Galvanic isolation of electrical voltages		[V] 80 DC
Protection against direct and indirect contact		PELV

Operating conditions		
Temperature range, electronics	Operation	[°C] -5 ... +50
	Storage/transport	[°C] -20 ... +70
Temperature range, electronics plus pneumatic components	Operation	[°C] -5 ... +50
	Storage/transport	[°C] -20 ... +40

Materials	
Housing	Die-cast aluminium, PA reinforced, PC

Certifications and approvals – Maximum values	
ATEX category for gas	II 3G
Explosion ignition protection type for gas	Ex nA IIC T4 X Gc
Explosion-proof temperature	[°C] $-5 \leq T_a \leq +50$
CE marking (see declaration of conformity)	To EU Explosion Protection Directive (ATEX)
	To EU EMC Directive ¹⁾
Protection class to EN 60529	IP20, IP65
Certification	cULus Recognized (OL)
	C-Tick
Explosion protection certification outside the EU	EPL Gc (Ru)

- 1) For information about the applicability of the component see the manufacturer's EC declaration of conformity at: www.festo.com → Support → User documentation.
If the component is subject to usage restrictions in residential, office or commercial locations or small businesses, further measures for the reduction of the emitted interference may be necessary.

Note

The values indicated represent the maximum performance limits that can be achieved with the fully assembled product. Depending on the individual components used, the value actually achieved for the overall product may be lower.

You can select e.g. the individual components required to achieve the ATEX category by choosing the corresponding features in the online product configurator:

→ Internet: cpx-p

Technical data – Bus node CPX-FB11

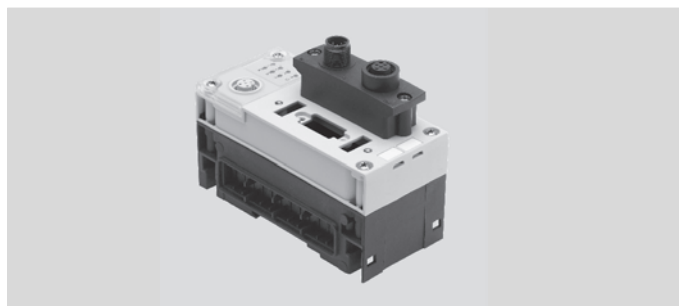

Technical data			Download CAD data → www.festo.com
Fieldbus interface	Either		Micro style bus connection: 2x M12 with protection to IP65/IP67 Open style bus connection: 5-pin terminal strip, IP20
Baud rates		[kbps]	125, 250, 500
Addressing range			0 ... 63, set using DIL switch
Communication types			Polled I/O, change of state/cyclic, strobed I/O and explicit messaging
Max. address capacity	Inputs/outputs	[byte]	64/64
Parameterisation			Module and system parameterisation via configuration interface in plain text (EDS) Online in run or program mode
Additional functions			Storage of the last 40 errors with timestamp (access via EDS) 8-bit system status in image table for inputs 2-byte inputs and 2-byte outputs, system diagnostics in image table
Current consumption		[mA]	Max. 200
Length/width/height (incl. interlinking block)		[mm]	107/50/50

Technical data – Bus node CPX-FB13

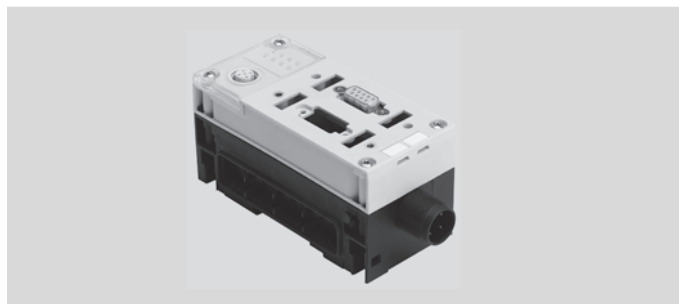

Technical data			Download CAD data → www.festo.com
Fieldbus interface			Sub-D socket, 9-pin (EN 50170), galvanically isolated 5 V
Baud rates		[Mbps]	0.0096 ... 12
Addressing range			1 ... 125, set using DIL switch
Communication types	DPV0		Cyclic communication
	DPV1		Acyclic communication
Max. address capacity	Inputs/outputs	[byte]	64/64
Parameterisation			Start-up via configuration interface in plain text (GSD) Acyclic parameterisation via DPV1
Additional functions			Storage of the last 40 errors with timestamp (access via DPV1) 8-bit system status in image table for inputs 2-byte inputs and 2-byte outputs, system diagnostics in image table
Current consumption		[mA]	Max. 200
Length/width/height (incl. interlinking block)		[mm]	107/50/50

Technical data – Bus node CPX-FB32



IT services:

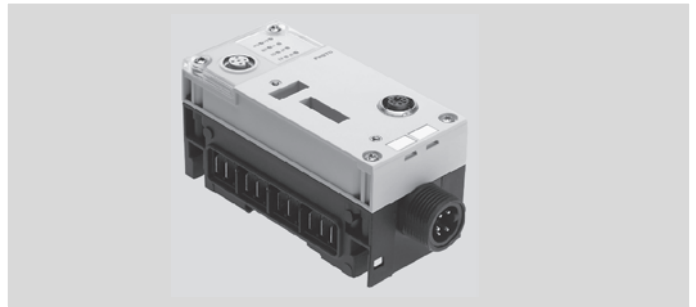

Technical data		Download CAD data → www.festo.com
Fieldbus interface		Plug connector M12, D-coded, 4-pin
Baud rates	[Mbps]	10/100, full/half duplex
IP addressing		Via DHCP, DIL switch or network software
Max. address capacity	Inputs/outputs	[byte] 64/64
Parameterisation		Start-up parameterisation
		Acyclic parameterisation via explicit messaging
Additional functions		Storage of the last 40 errors with timestamp (access via system diagnostics)
		8-bit system status in image table for inputs
		2-byte I/O, system diagnostics via image table
Current consumption	[mA]	Typically 65
Length/width/height (incl. interlinking block)	[mm]	107 x 50 x 50

Technical data – Bus node CPX-FB33



Technical data		Download CAD data → www.festo.com
Fieldbus interface		2x M12 socket, D-coded, 4-pin
Baud rates	[Mbps]	100
Max. address capacity	Inputs/outputs	[byte] 64/64
Parameterisation		System parameters
		Diagnostic behaviour
		Signal setup
		Fail-safe response
		Forcing of channels
Additional functions		Start-up parameterisation in plain text via fieldbus
		Fast start-up (FSU)
		Channel-oriented diagnostics via fieldbus
		Acyclic data access via fieldbus
		System status can be displayed using process data
		Additional diagnostic interface for operator units
	Acyclic data access via Ethernet	
Current consumption	[mA]	Typically 120
Length/width/height (incl. interlinking block)	[mm]	107/50/50

Technical data – Digital input module with 8 NAMUR inputs, CPX-P-8DE-N, CPX-P-8DE-N-IS

Possible connection blocks

CPX-P-8DE-N:

- CPX-P-AB-4XM12-4POL
- CPX-P-AB-2XKL-8POL

Possible connection blocks

CPX-P-8DE-N-IS:

- CPX-P-AB-4XM12-4POL-8DE-N-IS
- CPX-P-AB-2XKL-8POL-8DE-N-IS

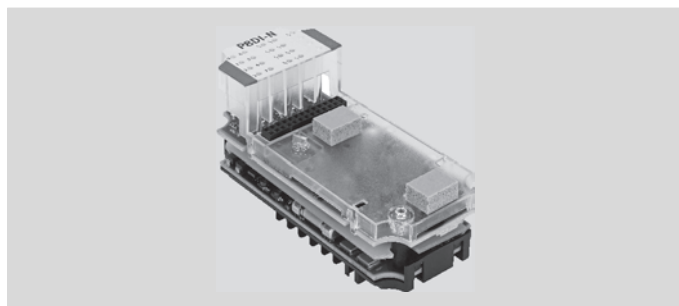

Technical data		Download CAD data → www.festo.com
Number of inputs		8
Max. cable length	[m]	200
Internal electronic fuse		Per channel
Intrinsic current consumption at operating voltage	[mA]	Typically 75
Electrical isolation	Channel – channel	No
	Channel – internal bus	Yes
Switching level		To EN 60947-5-6
Input characteristic		To EN 60947-5-6
Parameterisation	Data format	
	Input debounce time per channel	
	Input function per channel	
	Replacement value in diagnostic case per channel	
	Upper limit value per channel	
	Signal extension time per channel	
	Gate time per channel	
	Limit value monitoring per channel	
	Monitoring of short circuit per channel	
	Monitoring of wire break per channel	
	Monitoring of parameters	
	Lower limit value per channel	
	Counter configuration per channel	
Additional functions	Frequency measurement	
	Counter function	

Certifications and approvals – Maximum values		
Type	CPX-P-8DE-N	CPX-P-8DE-N-IS
ATEX category for gas	–	II (1) G
Explosion ignition protection type for gas	–	[Ex ia Ga] IIC
ATEX category for dust	–	II (1) D
Explosion ignition protection type for dust	–	[Ex ia Da] IIIC
Explosion protection certification outside the EU	–	EPL Da (IEC-EX)
	–	EPL Ga (IEC-EX)
Explosion-proof temperature	[°C]	–5 ≤ Ta ≤ +70
Certificate issuing authority	–	IECEx ZLM 12.0007 X
	–	ZELM 12 ATEX 0500 X

Note

The module CPX-P-8DE-N-IS has additional safety measures for possible faults such as non-resettable fuses to ensure safe operation as per the ignition protection type. If the module is operated within the permissible parameters, these protective measures will be irrelevant.

Note

Only the end plate, the pneumatic interface or another module in intrinsically safe design are permitted directly to the right of modules in intrinsically safe design (CPX-P-8DE-N-IS) within the CPX-P terminal.

Note

The insulating plate CPX-P-AB-IP must be mounted between a module in intrinsically safe design (CPX-P-8DE-N-IS) and another, non-intrinsically safe CPX input or output module.

Note

The above-mentioned certifications for the CPX-P-8DE-N-IS module do not apply if the module is used outside the appropriately configured terminal CPX-P.

Technical data – Digital input module with 16 inputs, CPX-16DE

Possible connection blocks

CPX-16DE:

- CPX-AB-8-M8X2-4POL
- CPX-AB-8-KL-4POL
- CPX-AB-1-SUB-BU-25POL

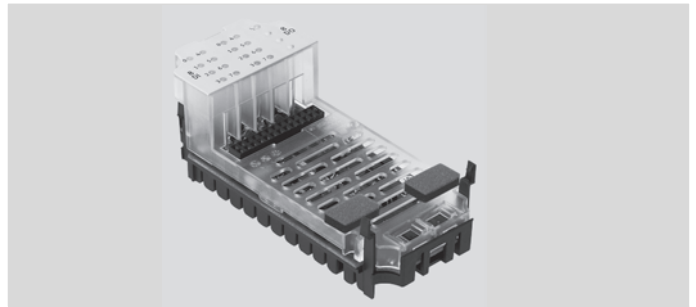

Technical data		Download CAD data → www.festo.com	
Type		CPX-16DE	
Number of inputs		16	
Max. residual current of inputs per module	[A]	1.8	
Internal electronic fuse		Per module	
Intrinsic current consumption at operating voltage	[mA]	Typically 15	
Sensor supply voltage	[V DC]	24 ±25%	
Electrical isolation	Channel – channel	No	
	Channel – internal bus	No	
Switching level	Signal 0 [V DC]	≤ 5	
	Signal 1 [V DC]	≥ 11	
Input characteristic		IEC 1131-2	
Switching logic		Positive logic (PNP)	
Parameterisation		Module monitoring	
		Behaviour after short circuit	
		Input debounce time	
		Signal extension time	

Technical data – Digital output module with 4 outputs, CPX-4DA

Possible connection blocks:

- CPX-AB-8-M8-3POL
- CPX-AB-8-M8X2-4POL
- CPX-AB-4-M12X2-5POL
- CPX-AB-4-M12X2-5POL-R
- CPX-AB-8-KL-4POL
- CPX-AB-1-SUB-BU-25POL
- CPX-AB-4-HAR-4POL
- CPX-M-AB-4-M12X2-5POL

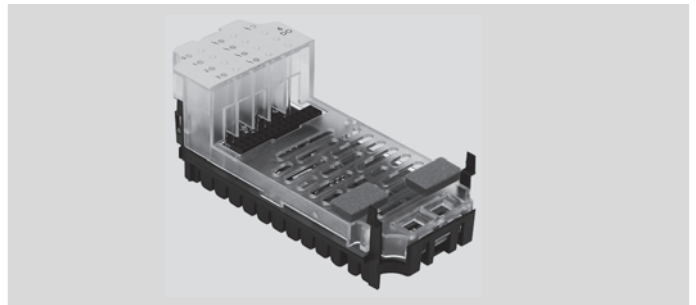

Technical data		Download CAD data → www.festo.com	
Type		CPX-4DA	
Number of outputs		4	
Max. power supply	Per module [A]	4	
	Per channel [A]	1 (24 W lamp load, 4 channels can be connected in parallel)	
Fuse protection (short circuit)		Internal electronic fuse per channel	
Module current consumption (voltage supply for electronics)	[mA]	Typically 16	
Supply voltage	[V DC]	24 ±25%	
Electrical isolation	Channel – channel	No	
	Channel – internal bus	Yes, using an intermediate supply	
Output characteristic		To IEC 1131-2	
Switching logic		Positive logic (PNP)	
Parameterisation		Module monitoring	
		Behaviour after short circuit	
		Fail-safe channel x	
		Forcing channel x	
		Idle mode channel x	

Technical data – Analogue output module with 2 inputs, CPX-2AA-U-I

Possible connection blocks:

- CPX-AB-4-M12X2-5POL
- CPX-AB-4-M12X2-5POL-R
- CPX-AB-8-KL-4POL
- CPX-AB-1-SUB-BU-25POL
- CPX-M-AB-4-M12X2-5POL

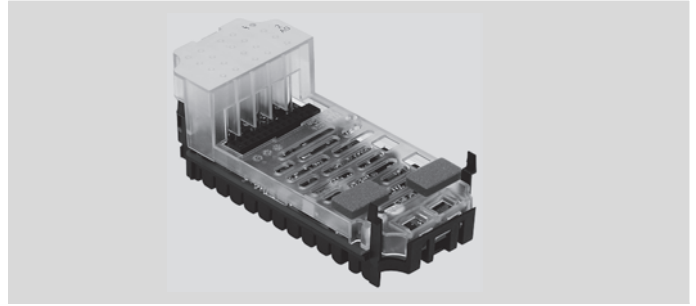

Technical data		Download CAD data → www.festo.com		
Type		CPX-2AA-U-I		
		Voltage output	Current output	
Number of outputs		2	2	
Max. actuator supply per module	[A]	2.8	2.8	
Fuse protection		Internal electronic fuse for actuator supply		
Current consumption from 24 V sensor supply (at full load)	[mA]	Max. 150	Max. 150	
Current consumption from 24 V actuator supply (at full load)	[A]	4 ... 10	4 ... 10	
Supply voltage for actuators	[V DC]	24 ±25%	24 ±25%	
Signal range (parameterisable for each channel by means of DIL switch or software)		0 ... 10 V DC	0 ... 20 mA 4 ... 2 mA	
Resolution		12 bits	12 bits	
Absolute accuracy	[%]	±0.6	±0.6	
Encoder selection	Load resistance for ohmic load	[kΩ]	Min. 1	Max. 0.5
	Load resistance for capacitive load	[μF]	Max. 1	–
	Load resistance for inductive load	[mH]	–	Max. 1
	Short circuit protection for analogue output		Yes	–
	Short circuit current of analogue output	[mA]	Approx. 20	–
	Open circuit voltage	[V DC]	–	18
	Destruction limit against externally applied voltage	[V DC]	15	15
	Actuator connection		2 wires	2 wires
Response time	For ohmic load	[ms]	0.1	0.1
	For capacitive load	[ms]	0.7	–
	For inductive load	[ms]	–	0.5
Data format		15 bits + prefix, linear scaling 12 bits left-aligned, S7 compatible 12 bits left-aligned, S5 compatible		
Cable length	[m]	Max. 30 (screened)		
Parameterisation		Short circuit monitoring, actuator supply		
		Short circuit monitoring, analogue output		
		Behaviour after short circuit, actuator supply		
		Data format		
		Lower limit value/full-scale value		
		Upper limit value/full-scale value		
		Monitoring of value falling below nominal range/full-scale value		
		Monitoring of value exceeding nominal range/full-scale value		
		Monitoring of wire break		
	Signal range			

Technical data – Interlinking block with system supply, CPX-M-GE-EV-S-7/8-5POL

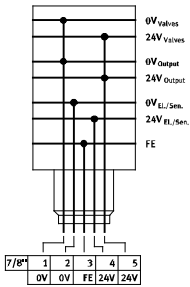

Download CAD data → www.festo.com

Technical data			Type
Type			CPX-M-GE-EV-S-7/8-5POL
Electrical connection			7/8", 5-pin
Nominal operating voltage		[V DC]	24
Current supply	Sensors and electronics	[A]	Max. 8
	Valves and outputs	[A]	Max. 8
Protection class to EN 60529			Depending on connection block
Ambient temperature		[°C]	-5 ... +50
Type of mounting			Angled fitting
Length/width/height		[mm]	107/50/35

Technical data – Interlinking block without supply, CPX-M-GE-EV

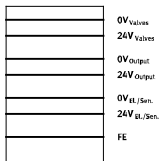

Download CAD data → www.festo.com

Technical data			Type
Type			CPX-M-GE-EV
Electrical connection			-
Nominal operating voltage		[V DC]	24
Acceptable current load (per contact/contact rail)		[A]	16
Protection class to EN 60529			Depending on connection block
Ambient temperature		[°C]	-5 ... +50
Type of mounting			Angled fitting
Length/width/height		[mm]	107/50/35

Technical data – Interlinking block with additional power supply for outputs, CPX-M-GE-EV-Z-7/8-5POL

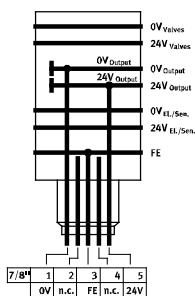

Technical data

Download CAD data → www.festo.com

Type	CPX-M-GE-EV-Z-7/8-5POL		
Electrical connection	7/8", 5-pin		
Nominal operating voltage	[V DC]	24	
Current supply	Outputs	[A]	Max. 8
Protection class to EN 60529	Depending on connection block		
Ambient temperature	[°C]	-5 ... +50	
Type of mounting	Angled fitting		
Length/width/height	[mm]	107/50/35	

Technical data – Pneumatic interface for valve terminal MPA-S, VMPA-FB-EPLM

Operating voltage
 24 V DC

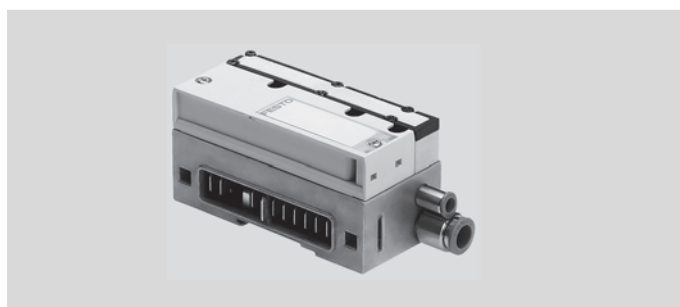

Technical data

Download CAD data → www.festo.com

Type	VMPA-FB-EPLM		
Type of mounting	Angled fitting		
Number of solenoid coils	128		
Max. intrinsic current consumption per electronics module at 24 V	[mA]	20 (regardless of the switching status of the valves)	
Max. intrinsic current consumption at 24 V (regardless of the switching status of the valves) per electronics module			
VMPA1-FB-EMS-8 or VMPA2-FB-EMS-4	[mA]	3 not galvanically isolated (max. signal line length 10 m)	
VMPA1-FB-EMG-8 or VMPA2-FB-EMG-4	[mA]	23 galvanically isolated	
Diagnostic message on undervoltage U_{OFF} Load voltage outside function range	[V]	17.5 ... 16	
Nominal pick-up current/duration per solenoid coil at nominal voltage	MPA1	[mA]	58/24 ms
	MPA2	[mA]	99/24 ms
Nominal current per solenoid coil at nominal voltage with current reduction	MPA1	[mA]	9 after 24 ms
	MPA2	[mA]	18 after 24 ms
Length/width/height	[mm]	107/51/55	



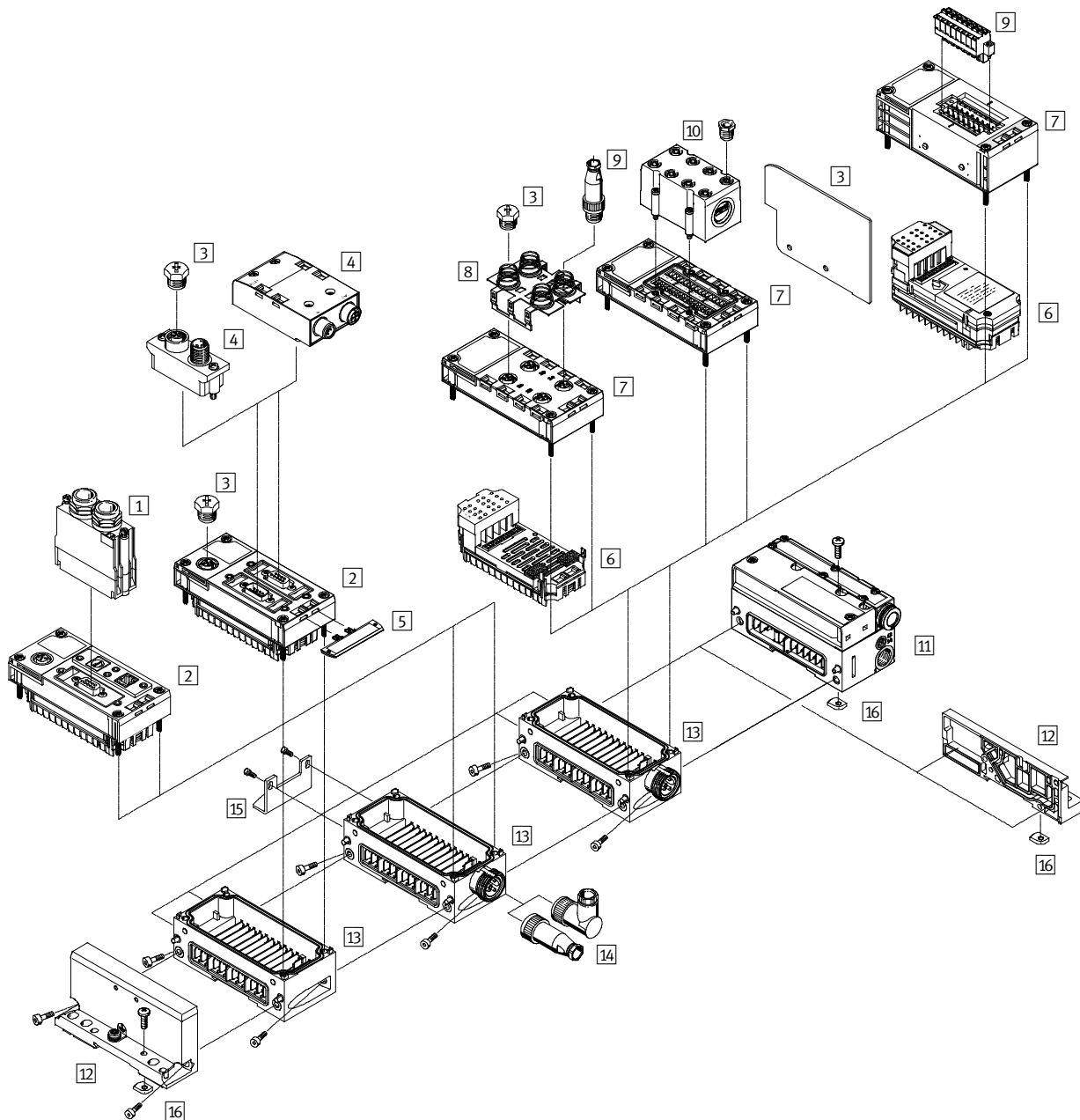







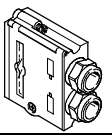
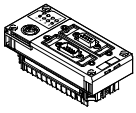

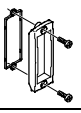
Accessories

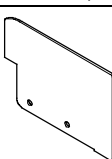

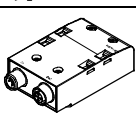

		→ Page/ online
1	Plug FBS-SUB-9 for fieldbus connection (version dependent on bus type)	984
2	CPX bus node CPX-FB	984
3	Cover cap ISK/CPX-P-KDS/CPX-P-AB/AK-SUB (for unused connections)	984
4	Connector plug FBA/FBS/NECU/FBSD/CPX-AB for fieldbus connection	984
5	Inscription label IBS/CPX-ST	985
6	CPX module CPX (analogue/digital/NAMUR input/output module)	985
7	Connection block CPX-AB/CPX-M-AB/CPX-P-AB	985
8	Screening plate CPX-AB-S	985
9	Connector plug/connecting cable KM12/KM8 for inputs/outputs	986

		→ Page/ online
10	Cover AK-8KL for CPX-AB-8-KL-4POL (IP65/67)	986
11	Pneumatic interface VMPA-FB-EPLM	986
12	End plate CPX-M-EP	986
13	Interlinking block CPX-M-GE (with/without voltage supply)	986
14	Connector plug NECU for power supply	987
15	Mounting components CPX-M-BG-RW for wall mounting	987
16	H-rail mounting CPX-CPA-BG-NRH	987
-	Hood CAFC	987
-	Memory card CPX-SK-2 for PROFINET bus node	987
-	User documentation P.BE-CPX	987

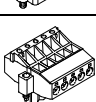

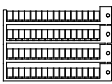
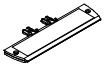

Accessories – Ordering data

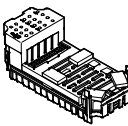
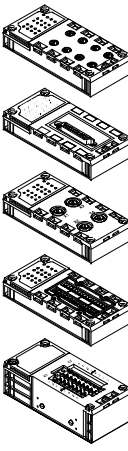
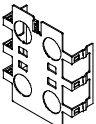
	Description	Part No.	Type
1 Plug for fieldbus connection, Sub-D Technical data online: → fbs			
	For DeviceNet/CANopen	532219	FBS-SUB-9-BU-2x5POL-B
	For PROFIBUS-DP	532216	FBS-SUB-9-GS-DP-B
2 CPX bus node Technical data → 977			
	DeviceNet	526172	CPX-FB11
	PROFIBUS DP	★ 195740	CPX-FB13
	Ethernet/IP with M12	541302	CPX-FB32
	PROFINET with M12, D-coded, 4-pin	548755	CPX-FB33
3 Cover cap			
	For M8 connections (packaging unit 10 pieces)	177672	ISK-M8
	For M12 connections (packaging unit 10 pieces)	165592	ISK-M12
	Inspection cover, for DIL switch and bus connection	Transparent	533334 AK-SUB-9/15-B
	Coding element (96 pieces of each)	For NECU-L3G8	565713 CPX-P-KDS-AB-2XKL
	Insulating plate for safe separation of intrinsically safe and non-intrinsically safe areas of the CPX-P terminal	565708	CPX-P-AB-IP ¹⁾
4 Connector plug for fieldbus connection Technical data online: → necu			
	M12 adapter (B-coded) for PROFIBUS DP	533118	FBA-2-M12-5POL-RK
	Micro style, 2x M12 for DeviceNet/CANopen	525632	FBA-2-M12-5POL
	Socket for micro style connection, M12	18324	FBSD-GD-9-5POL
	Plug for micro style connection, M12	175380	FBS-M12-5GS-PG9
	Plug M12x1, 4-pin, D-coded, for PROFINET	543109	NECU-M-S-D12G4-C2-ET
	Socket M12x1, for FBA-2-M12-5POL-RK and CPX-AB-2-M12-RK-DP	1067905	NECU-M-B12G5-C2-PB
	Plug M12x1, for FBA-2-M12-5POL-RK and CPX-AB-2-M12-RK-DP	1066354	NECU-M-S-B12G5-C2-PB
	M12 adapter for PROFIBUS DP (B-coded)	541519	CPX-AB-2-M12-RK-DP
	Open style for 5-pin terminal strip, for DeviceNet/CANopen	525634	FBA-1-SL-5POL
	5-pin terminal strip, for DeviceNet/CANopen	525635	FBSD-KL-2x5POL

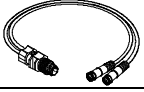

Accessories – Ordering data

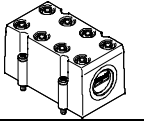
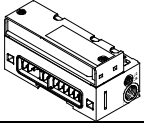
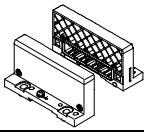
	Description	Part No.	Type	
5 Inscription label				
	Inscription labels 6x10 mm, in frame (64 pieces)	18576	IBS-6x10	
	Inscription label holder for connection block M12	536593	CPX-ST-1	
	Screws for attaching an inscription label holder to the bus node (12 pieces)	550222	CPX-M-M2,5X8-12X	
6 CPX module Technical data → 978				
	8 digital inputs to NAMUR	565934	CPX-P-8DE-N-IS	
	8 digital inputs to NAMUR, intrinsically safe design	565933	CPX-P-8DE-N	
	8 digital inputs PNP	★ 195750	CPX-8DE	
	8 digital inputs NPN	543813	CPX-8NDE	
	16 digital inputs	543815	CPX-16DE	
	4 digital outputs	195754	CPX-4DA	
	2 analogue outputs	526170	CPX-2AA-U-I	
7 Connection block				
	For NAMUR modules			
	For intrinsically safe design	4x socket, M12, 4-pin	565705	CPX-P-AB-4XM12-4POL-8DE-N-IS
		2x plug, 8-pin	565703	CPX-P-AB-2XKL-8POL-8DE-N-IS
	For non-intrinsically safe design	4x socket, M12, 4-pin	565706	CPX-P-AB-4XM12-4POL
		2x plug, 8-pin	565704	CPX-P-AB-2XKL-8POL
	Plastic design			
	8 connections M8, 3-pin	★	195706	CPX-AB-8-M8-3POL
	8 connections M8, 4-pin		541256	CPX-AB-8-M8X2-4POL
	4 connections M12, 5-pin	★	195704	CPX-AB-4-M12x2-5POL
	4 connections M12, 5-pin, with quick lock and metal thread		541254	CPX-AB-4-M12x2-5POL-R
	8 spring-loaded terminal connections, 4-pin	★	195708	CPX-AB-8-KL-4POL
	Sub-D socket, 25-pin		525676	CPX-AB-1-SUB-BU-25POL
	4 connections in HARAX fast connection technology, 4-pin		525636	CPX-AB-4-HAR-4POL
Metal design				
4 connections M12, 5-pin		549367	CPX-M-AB-4-M12x2-5POL	
8 Screening plate				
	For M12 connections	526184	CPX-AB-S-4-M12	

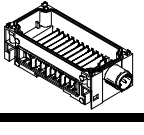
Accessories – Ordering data

	Description	Part No.	Type
9 Connector plug/connecting cable for inputs/outputs, DUO connecting cable M12, 4-pin Technical data online: → km12			
	2x straight socket	18685	KM12-DUO-M8-GDGD
	2x straight/angled socket	18688	KM12-DUO-M8-GDWD
	2x angled socket	18687	KM12-DUO-M8-WDWD
Connecting cable Technical data → 949			
	M8-M8 3-pin/3-pin	0.5 m	175488 KM8-M8-GSGD-0,5
		1.0 m	175489 KM8-M8-GSGD-1
		2.5 m	165610 KM8-M8-GSGD-2,5
		5.0 m	165611 KM8-M8-GSGD-5
	M12-M12 4-pin/4-pin	2.5 m	18684 KM12-M12-GSGD-2,5
		5.0 m	18686 KM12-M12-GSGD-5
		1.0 m	185499 KM12-M12-GSWD-1-4
10 Cover for CPX-AB-8-KL-4POL (IP65/67)			
	- 8 cable through-feeds M9 - 1 cable through-feed for multi-pin plug	★ 538219	AK-8KL
	Fittings kit for cover AK-8KL	★ 538220	VG-K-M9
11 Pneumatic interface, for valve terminal MPA-S Technical data → 982			
	Ducted exhaust air	Internal pilot air	552286 VMPA-FB-EPLM-G
		External pilot air	552285 VMPA-FB-EPLM-E
	Flat plate silencer	Internal pilot air	552288 VMPA-FB-EPLM-GU
		External pilot air	552287 VMPA-FB-EPLM-EU
12 End plates			
	Metal design	Right-hand	550214 CPX-M-EPR-EV
		Left-hand	550212 CPX-M-EPL-EV
13 Interlinking block, with system supply Technical data → 981			
	Metal design	7/8" connection, 5-pin	550208 CPX-M-GE-EV-S-7/8-5POL
		Without supply	
	Metal design	★ 550206	CPX-M-GE-EV
With additional power supply for outputs			
	Metal design	7/8" connection, 5-pin	550210 CPX-M-GE-EV-Z-7/8-5POL

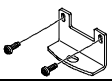
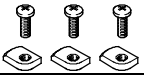
Accessories – Ordering data

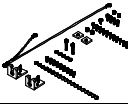
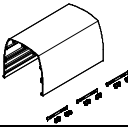
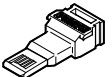
	Description	Part No.	Type
14 Connector plug for power supply Technical data online: → ntsd			
	7/8" connection	543107	NECU-G78G5-C2
15 Attachment for wall mounting			
	For long valve terminals, 2 mounting brackets and 4 screws, for metal manifold sub-bases	550217	CPX-M-BG-RW-2x
16 H-rail mounting			
	For mounting CPX terminal and valve terminal on H-rail	★ 526032	CPX-CPA-BG-NRH
Hood			
	Mounting rail for attaching the hood, 1 m	572256	CAFC-X1-S
	Mounting kit for CPX hood	572257	CAFC-X1-BE
	Hood section	200 mm	572258 CAFC-X1-GAL-200
		300 mm	572259 CAFC-X1-GAL-300
Memory card			
	For PROFINET bus node (CPX-FB33), 2MB	568647	CPX-SK-2

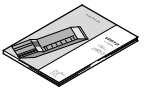
	Description	Part No.	Type
Manual			
	Bus node CPX-FB11		
	German	526421	P.BE-CPX-FB11-DE
	English	526422	P.BE-CPX-FB11-EN
	French	526424	P.BE-CPX-FB11-FR
	Italian	526425	P.BE-CPX-FB11-IT
	Spanish	526423	P.BE-CPX-FB11-ES
	Swedish	526426	P.BE-CPX-FB11-SV
	Bus node CPX-FB13		
	German	526427	P.BE-CPX-FB13-DE
	English	526428	P.BE-CPX-FB13-EN
	French	526430	P.BE-CPX-FB13-FR
	Italian	526431	P.BE-CPX-FB13-IT
	Spanish	526429	P.BE-CPX-FB13-ES
	Swedish	526432	P.BE-CPX-FB13-SV
	Bus node CPX-FB32		
	German	541304	P.BE-CPX-FB32-DE
	English	541305	P.BE-CPX-FB32-EN
	Spanish	541306	P.BE-CPX-FB32-ES
	Bus node CPX-FB33		
	German	548759	P.BE-CPX-PNIO-DE
	English	548760	P.BE-CPX-PNIO-EN
Spanish	548761	P.BE-CPX-PNIO-ES	

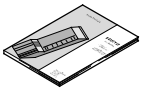
	Description	Part No.	Type
Manual			
	CPX system manual		
	German	526445	P.BE-CPX-SYS-DE
	English	526446	P.BE-CPX-SYS-EN
	Spanish	526447	P.BE-CPX-SYS-ES
	French	526448	P.BE-CPX-SYS-FR
	Italian	526449	P.BE-CPX-SYS-IT
	Swedish	526450	P.BE-CPX-SYS-SV
	Digital input/output modules		
	German	526439	P.BE-CPX-EA-DE
	English	526440	P.BE-CPX-EA-EN
	Spanish	526441	P.BE-CPX-EA-ES
	Analogue input/output modules		
	German	526415	P.BE-CPX-AX-DE
	English	526416	P.BE-CPX-AX-EN
	Spanish	526417	P.BE-CPX-AX-ES



16 Other pneumatic devices

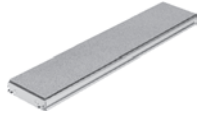

Air cushion plates

	
Type	Air cushion plate ATBT
Size	100
Operating pressure	≤2 bar
Pneumatic connection	G1/4
Bearing length	100 ... 1,500 mm
Max. surface load during operation	400 kg/m ²
Repetition accuracy of the cushion height	±10 μm
Description	<ul style="list-style-type: none"> • Works without contact by means of an air cushion, with low compressed air consumption • Uniform air flow ensures maximum precision and allows for short cycle times • For transporting and conveying flat products • Suitable for vacuum, can be used as a flat suction cup
→ Page/online	atbt



Air reservoirs

		
Type	Air reservoir VZS	Air reservoir CRVZS
Volume	20 l	0.1 l, 0.4 l, 0.75 l, 2 l, 5 l, 10 l, 20 l
Information on air reservoir materials	Steel, painted	High-alloy stainless steel
Conforms to standard	EN 286-1	AD 2000
Condensate drain connection	G3/8	G3/8
Description	<ul style="list-style-type: none"> • Compensation of pressure fluctuations • Provision of large quantities of compressed air for supplying fast pulsing drives • Volume up to 20 l • With condensate drain 	<ul style="list-style-type: none"> • Corrosion-resistant • Volume up to 20 l • Available with condensate drain • Can be used to compensate pressure fluctuations, and act as accumulators in the event of sudden air consumption • Provision of large quantities of compressed air for supplying fast pulsing drives • Designs in accordance with EU Pressure Equipment Directive
→ Page/online	vzs	993



Silencers

				
Type	Silencer U	Silencer UC	Silencer AMTC	Silencer UO
Information on silencer insert materials	Bronze, PE	PE	PE	PE
Pneumatic connection	G1/8, G1/4, G3/8, G1/2, G3/4, G1, M3, M5, NPT3/4-14, PK-3, PK-4	G1/8, G1/4, M5, M7, QS-3, QS-4, QS-6, QS-8, QS-10	QSP...10	G1/8, G1/4, M7
Noise level	65 ... 84 dB(A)	58 ... 68 dB(A)	58 dB(A)	
Description	<ul style="list-style-type: none"> • Compact design, plastic or die-cast • Barbed fitting or threaded connection • RoHS-compliant designs 	<ul style="list-style-type: none"> • Design with push-in sleeve for push-in fitting QS or threaded connection for solenoid valves CPE • Plastic design 	<ul style="list-style-type: none"> • For solenoid valve VUVBST12/valve terminal VTUB-12 • Attached via pin (spring clip), included in the scope of delivery of the valve 	<ul style="list-style-type: none"> • Special minimal resistance silencer • For vacuum generator VN • Facilitates trouble-free operation
→ Page/online	994	uc	amtc	uo



Silencers

		
Type	Silencer UOS-1	Silencer UOM, UOMS
Information on silencer insert materials	PE	PU foam
Pneumatic connection	G1	G1/4, G3/8
Noise level		
Description	<ul style="list-style-type: none"> • For soft-start/quick exhaust valve MS6-SV, MS series • Mounting via male thread 	<ul style="list-style-type: none"> • Silencer and silencer extension • For vacuum generators • Special minimal resistance silencer • Facilitates trouble-free operation of the vacuum generator • Silencer extension for extending the silencer for further noise reduction
→ Page/online	uos	uom



Air guns

		
Type	Low consumption air gun LSP	Air nozzle LPZ
Exhaust function	Metered blowing	
Pneumatic connection	Female thread G1/4	Male thread M12x1.25
Information on housing materials	Wrought aluminium alloy, PA6 reinforced	Aluminium, brass, die-cast zinc, chrome-plated, nickel-plated
Description	<ul style="list-style-type: none"> • Precise, infinitely variable, lever-operated flow metering • Interchangeable nozzles • Pneumatic connection via female thread 	<ul style="list-style-type: none"> • With protective air shield or silencer • Targeted, strong air jet or powerful, focused air jet • Low noise level
→ Page/online	lsp	lpz

Pneumatic indicators

		
Type	Pressure indicator OH	Pneumatic terminal, end clamp, distributor LT, LTE, LTV
Design	Indicator plate with 16 pressure indicators, indicating pin with spring return, reflection principle	
Size	8, 10, 22	
Operating pressure	-1 ... 8 bar	0.1 ... 8 bar
Pneumatic connection	G1/8, barbed connector PK-3	Barbed connector PK-3, barbed connector PK-4, G1/8
Type of mounting	Front panel mounting, 2 through-holes in the housing or on 2n mounting frame	Can be snapped onto mounting rail type NRC-32
Description	<ul style="list-style-type: none"> • Visual indicator • Indicator colours: red, blue, yellow or green 	<ul style="list-style-type: none"> • Pneumatic terminal for checking the incoming and outgoing signals at the controller input or output • Up to 15 distributor pieces with common air supply, for easy connection
→ Page/online	oh	lt

Inscription systems

		
Type	Inscription label ASLR, BZ, HWF, IBS, KM, KMC, MH, SBS, SIEZ-LB	Inscription label holder CPV10-VI-ST, CPV14-VI-ST, CPV18-VI-ST, CPVSC1-ST, CPX-ST, IBT, MN2H-BZT, MVH-BZ, VMPA1-ST
Type of mounting	Inscription clip is pressed onto a cable, pressed into a holder or carrier, through-hole	Plug on, snap in, clip on
Height	4.5 ... 11 mm	
Width	9 ... 20 mm	
Description	<ul style="list-style-type: none"> • For labelling items • Can be inserted in holders or carriers on suitably equipped components 	<ul style="list-style-type: none"> • Holder for inscription labels • For components without pre-assembled carriers
→ Page/online	aslr	ascf



- Stainless steel design
- Volume:
up to 20 l
- AD 2000
- Approved by the German Technical Control Board (TÜV)

→ www.festo.com/catalogue/crvzs

Technical data

Technical data		Download CAD data → www.festo.com							
Type		CRVZS-0.1	CRVZS-0.4	CRVZS-0.75	CRVZS-2	CRVZS-5	CRVZS-10	CRVZS-20	
Pneumatic connection		G $\frac{1}{8}$	G $\frac{1}{4}$		G $\frac{1}{2}$	G1			
Condensate drain connection		-					G $\frac{3}{8}$		
Type of mounting		Via retaining clips			Via through-hole				
Mounting position		Any				Condensate drain underneath			
Volume	[l]	0.1 ±20%	0.4 ±20%	0.75 ±20%	2 ±10%	5 ±10%	10 ±10%	20 ±10%	
Length/width/height	[mm]	132/51/71	240/54/84	248/60/95	300/134/110	330/162/195	558/162/195	740/162/233	

Operating conditions

Operating medium		Compressed air to ISO 8573-1:2010 [-:-:-]
		Nitrogen
Operating pressure	[bar]	-0.95 ... +16
Ambient temperature	[°C]	-10 ... +100 (observe operating range of tubing and piping)
Suitable for use in the food industry		As per manufacturer's declaration

Materials

Type		CRVZS-0.1	CRVZS-0.4	CRVZS-0.75	CRVZS-2	CRVZS-5	CRVZS-10	CRVZS-20
Air reservoir		High-alloy stainless steel						
Retaining clips		High-alloy stainless steel				-		

Order code

CRVZS			
Type			
CRVZS	Air reservoir		
Volume [l]			
0.1, 0.4, 0.75, 2, 5, 10, 20			

Ordering – Product options

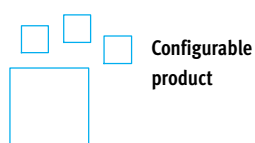

Configurable product

This product and all its options can be ordered using the configurator.

The configurator can be found under Products on the DVD or

→ www.festo.com/catalogue/...

Enter the type code in the search field.



- Simple screw-in attachment
- Compact design
- High flow rates:
up to 19,900 l/min
- Wide range of variants:
M3 to M5 and G1/8 to G1
- ★ Quick ordering of basic designs → 995

→ www.festo.com/catalogue/u

Product range overview

Type	Version	Pneumatic connection			→ Page/ online
		Male thread	Female thread	Barbed connector	
U	Sintered metal	M3, M5	–	–	995
		–	–	PK-3, PK-4	u-pk-*
	Polymer	G1/8, G1/4, G3/8, G1/2, G3/4, G1	–	–	995
		–	G1/8	–	u
	Die casting	G1/8, G1/4, G3/8, G1/2, G3/4, G1	–	–	995
		NPT3/4-14	–	–	u

Technical data

Operating conditions		
Operating medium	Compressed air to ISO 8573-1:2010 [7:-:-]	
Note on operating/pilot medium	Lubricated operation possible (in which case lubricated operation will always be required)	
Operating pressure [bar]	0 ... 10	
Ambient temperature ¹⁾ [°C]	–10 ... +70	

1) Note operating range of tubing used.

Note

Clean silencers with kerosene or benzene (not with trichloroethylene).

Materials			
Version	Sintered metal	Polymer	Die casting
Threaded plug	Brass	POM	Die-cast aluminium
Silencer insert	Bronze	PE	PE

★ Quick ordering

Silencer U

Sintered metal



Pneumatic connection	Noise level ¹⁾ [db (A)]	Flow rate with respect to atmosphere ²⁾ [l/min]	Part No.	Type	PU ³⁾
M3	< 65	110	★ 163978	U-M3	10
M5	< 70	320	★ 4645	U-M5	10
			534221	U-M5-50	50

Silencer U

Polymer



Pneumatic connection	Noise level ¹⁾ [db (A)]	Flow rate with respect to atmosphere ²⁾ [l/min]	Part No.	Type	PU ³⁾
G $\frac{1}{8}$	< 77	2,050	★ 2307	U- $\frac{1}{8}$	1
			534222	U- $\frac{1}{8}$ -50	50
G $\frac{1}{4}$	< 77	3,400	★ 2316	U- $\frac{1}{4}$	1
			534223	U- $\frac{1}{4}$ -20	20
G $\frac{3}{8}$	< 82	5,900	★ 2309	U- $\frac{3}{8}$	1
			534224	U- $\frac{3}{8}$ -20	20
G $\frac{1}{2}$	< 80	10,600	★ 2310	U- $\frac{1}{2}$	1
			534225	U- $\frac{1}{2}$ -20	20
G $\frac{3}{4}$	< 83	15,000	2311	U- $\frac{3}{4}$	1
G1	< 84	19,900	2312	U-1	1

Silencer U

Die casting



Pneumatic connection	Noise level ¹⁾ [db (A)]	Flow rate with respect to atmosphere ²⁾ [l/min]	Part No.	Type	PU ³⁾
G $\frac{1}{8}$	< 74	1,204	★ 6841	U- $\frac{1}{8}$ -B	1
G $\frac{1}{4}$	< 80	2,838	★ 6842	U- $\frac{1}{4}$ -B	1
G $\frac{3}{8}$	< 80	5,734	★ 6843	U- $\frac{3}{8}$ -B	1
G $\frac{1}{2}$	< 80	7,622	★ 6844	U- $\frac{1}{2}$ -B	1
G $\frac{3}{4}$	< 81	13,266	6845	U- $\frac{3}{4}$ -B	1
G1	< 80	15,102	151990	U-1-B	1

1) Measured at 6 bar with respect to atmosphere at a distance of 1 m.



2) Measured at p₁ = 6 bar.

3) Packaging unit

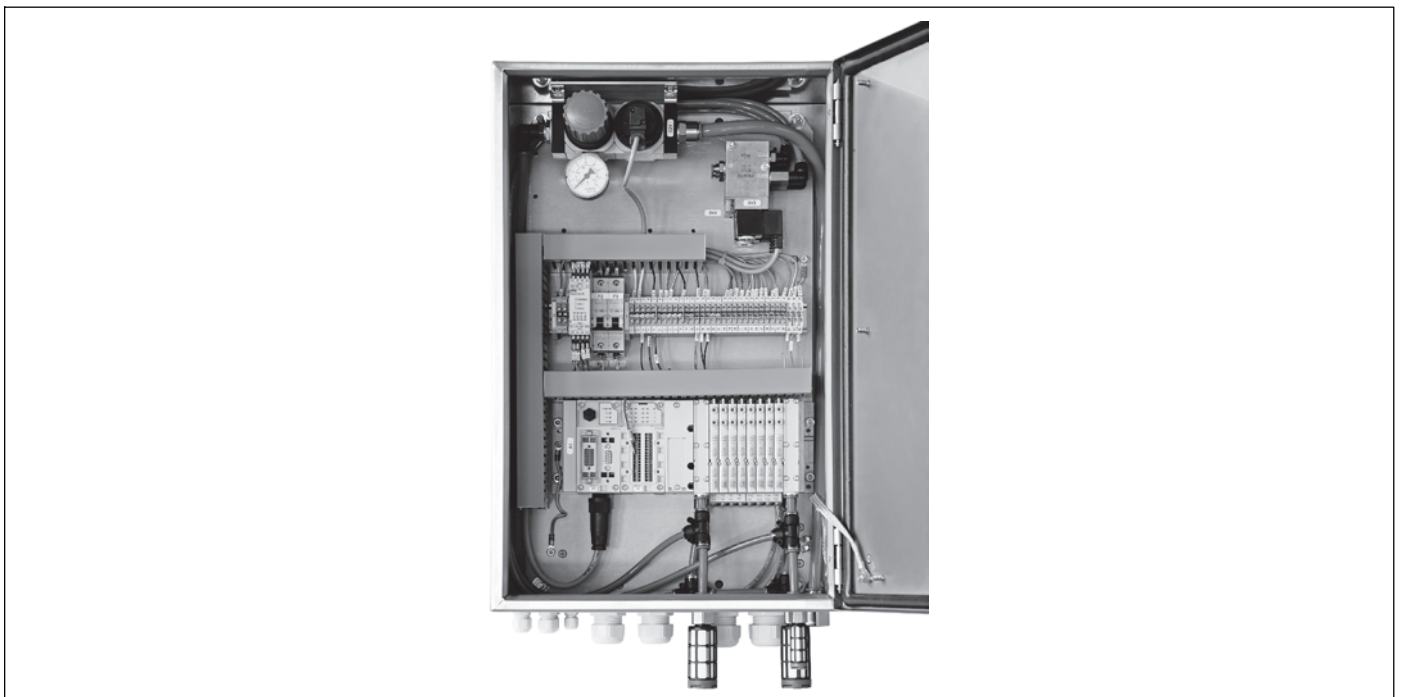

17 Ready-to-install solutions







Control cabinets

Type	 Factory automation	 Process automation	 Control cabinets for controllers
Technical data	<ul style="list-style-type: none"> • Simple to complex control cabinet designs • Application-specific combination of components • Fully tested, with test certificate • Ready-to-install • Complete documentation • Design conforms to: <ul style="list-style-type: none"> – EN 60204-1 – ATEX zone 1 and 21 (pneumatic only), ATEX zone 2 and 22 (electric and electro-pneumatic) – UL508A • Implementation of safety functions • Different bus technologies 	<ul style="list-style-type: none"> • Simple to complex control cabinet designs • Application-specific combination of components • Different operating voltages • Fully tested, with test certificate • Ready-to-install • Complete documentation • Design conforms to: <ul style="list-style-type: none"> – EN 60204-1 – ATEX zone 1 and 21 (pneumatic only), ATEX zone 2 and 22 (electric and electro-pneumatic) – UL508A • Implementation of safety functions • Wide range of bus technologies • Compliance with special cleanliness and hygiene requirements • Special materials • Protected against the ingress of liquids and foreign matter • Heating or cooling elements • Intrinsically safe valve terminal technology • Hot swap inspection window 	<ul style="list-style-type: none"> • Simple to complex control cabinet designs • 1 ... 31 axes • Application-specific combination of components • Use of the latest innovations and technologies • Fully tested, with test certificate • Ready-to-install • Complete documentation • Design conforms to: <ul style="list-style-type: none"> – EN 60204-1 – ATEX zone 1 and 21 (pneumatic only), ATEX zone 2 and 22 (electric and electro-pneumatic) – UL508A • Implementation of safety functions • Wide range of bus technologies
Description	<ul style="list-style-type: none"> • Control cabinets made to measure • Pneumatic, electric, combined • Individually configured • Adapted to requirements in industrial automation • Design and sizing included 	<ul style="list-style-type: none"> • Control cabinets made to measure • Pneumatic, electric, combined • Individually configured • Adapted to requirements in process automation • Design and sizing included 	<ul style="list-style-type: none"> • Made-to-measure control cabinets for handling systems • Software package for third-party devices included • Individually configurable • Adapted to requirements for handling solutions → 503
→ Page/online	1001	1003	1004

Mounting plates and assemblies

Type	 Mounting plates	 Assemblies
Technical data	<ul style="list-style-type: none"> • Customised shape • Support plate in different materials • Application-specific combination of components • Fully assembled, connected and wired • Defined interfaces • Ready-to-install • Fully tested, with test certificate • Complete documentation • Design conforms to: <ul style="list-style-type: none"> – EN 60204-1 – ATEX zone 1 and 21 (pneumatic only), ATEX zone 2 and 22 (electric and electro-pneumatic) – UL508A • Implementation of safety functions 	<ul style="list-style-type: none"> • Combination of various pneumatic and/or electrical components to create a single unit • Application-specific combination of components • Accessories mounted on sub-assembly • Use of the latest innovations and technologies • Ready-to-install • Fully tested, with test certificate • Complete documentation • Design conforms to: <ul style="list-style-type: none"> – EN 60204-1 – ATEX zone 1 and 21 (pneumatic only), ATEX zone 2 and 22 (electric and electro-pneumatic) – UL508A • Implementation of safety functions
Description	<ul style="list-style-type: none"> • Machine-specific pre-assembly of pneumatic and electrical components on support plate • Tubing and wiring included • Defined interfaces for easy installation directly in the system 	<ul style="list-style-type: none"> • Pneumatic and electrical components pre-assembled to create a function unit • Can be combined from around 30,000 catalogue components • Connections included • For integration in machines
→ Page/online	1005	1007

Integration solutions

Type	 Manifold duct plates	 Cartridge solutions	 Sheet-metal constructions and special housings	 Function blocks
Technical data	<ul style="list-style-type: none"> • Freely selectable manifold duct plate shape • Combination of over 30,000 catalogue components • High density of components • No tubing • Variable positioning of mechanical, pneumatic and electrical interfaces • Integration of customised components • Available with protective cover • Fully tested • Ready-to-install • Complete documentation • Implementation of safety functions 	<ul style="list-style-type: none"> • Space-saving thanks to extremely compact design • Pneumatic functions integrated in a single compact housing • Housing in different materials • No tubing required • Minimal cabling required • Significant design freedom • Variable integration options on and within the machine • Sturdy design • Fully tested • Ready-to-install • Complete documentation 	<ul style="list-style-type: none"> • Sheet-metal constructions <ul style="list-style-type: none"> – Customised shape and size – Reduced weight and number of assembly parts • Special housing <ul style="list-style-type: none"> – Customised shape – Customised dimensions – Various materials – Compact, space-optimised format – Protection against environmental influences and unauthorised access • In combination <ul style="list-style-type: none"> – Alternative to conventional control cabinets – Variable integration options on and within the machine – Short tubing and cable lengths – Attractive design 	<ul style="list-style-type: none"> • No tubing required thanks to drilled ducts • Housing available in different materials • Customised design of the pneumatic interfaces for the system • Ideal for a small number of components and variable connection options • Extremely economical, even for small quantities
Description	<ul style="list-style-type: none"> • Ideal for a large number of pneumatic connections in an extremely compact space • No tubing • Compact • Easy to service • Immune to malfunction 	<ul style="list-style-type: none"> • Integration of various pneumatic functions in one component • No need for single housings • Ideal for applications that require a highly compact design 	<ul style="list-style-type: none"> • Reduced weight thanks to optimal use of materials with sheet-metal constructions • Protection against environmental influences and unauthorised access • Ideally combined as a control cabinet directly in the system 	<ul style="list-style-type: none"> • Compressed air supply for pneumatic components via drilled ducts • Ideal for a small number of pneumatic components and variable connection options • Compact and easy to service
→ Page/online	1009	1011	1013	1015

Integration solutions

Type	 Profile solutions
Technical data	<ul style="list-style-type: none"> • Profiles in customised cross sections and lengths • Integrated ducts for straight-line routing of the compressed air • Common air supply for multiple valves or valve terminals via a single duct • Combination of exhaust air and supply air without tubing, even over long distances • Supply of compressed air at different locations • No tubing required • Significantly reduced cabling • Modular, easy to realise construction • Optional: profile as mechanical mounting element for other components or as a supporting part of the machine frame
Description	<ul style="list-style-type: none"> • Extruded profiles in combination with valves as a valve terminal • For the distribution of compressed air in the machine concept • Customised profile cross sections available
→ Page/online	1017

8 The benefit to you

- Low logistical costs when ordering just one item
- Minimal assembly and installation effort with Festo plug & work®
 - Straightforward assembly principles
 - Defined interfaces
 - Teach-in or parameterisation functions

Our service

- Delivery of a ready-to-install system
- Commissioning service

1 The benefit to you

- Consideration of application-specific requirements
- Systematic support right from the start
- Expert know-how included

Our service

- Personal advice in 59 countries
- Pneumatic, servopneumatic, electrical and mechatronic technologies
- Application- and industry-specific

7 The benefit to you

- Complete documentation, quickly integrated into overall documentation

Our service

- Detailed system documentation:
 - Assembly drawing
 - Bill of materials
 - Circuit diagrams
 - Operating instructions for components

6 The benefit to you

- Maximum reliability with regard to function and quality
- Including expertise on standards and directives

Our service

- 100% functional test
- Leak test
- Test certificate
- Certifications, e.g. EN 60204-1, ATEX, UL-508A

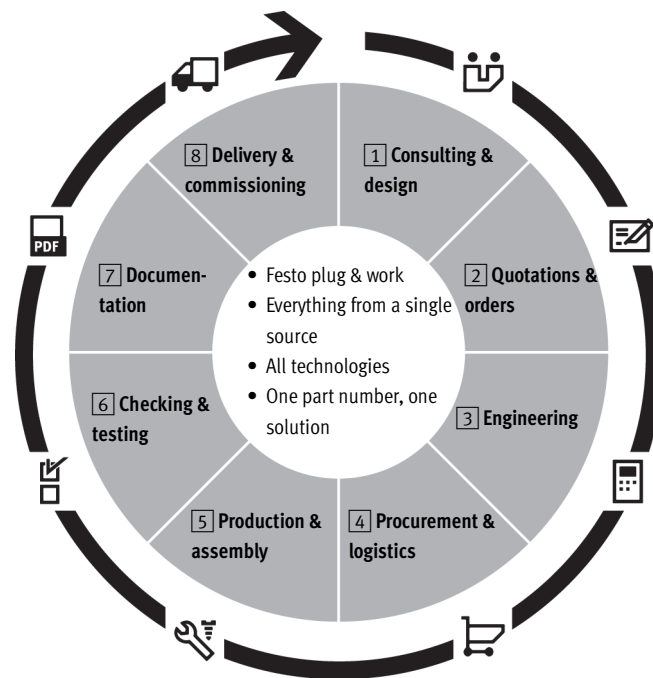

2 The benefit to you

- Detailed quotation with engineering concept
- Easy order processing with just one order item for the entire solution
- One delivery date

Our service

- Quotation includes:
 - 2D/3D concept
 - Bill of materials
 - Scope of services
 - Functional sequence

3 The benefit to you

- No engineering effort required
- Individually tailored solutions based on application-specific requirements
- Solution based on the latest technological standards

Our service

- Complete engineering solution:
 - Technology and component selection
 - Sizing of solutions
 - CAD design (2D/3D)
 - Circuit diagram creation
 - Simulation

5 The benefit to you

- Reduced manufacturing involvement as no in-house machining is required
- Easy to service and clear layout

Our service

- Application-specific mechanical production
- Assembly of all individual components
- Installation of third-party components possible
- Complete tubing and wiring

4 The benefit to you

- Reduced costs thanks to single sourcing
- No procurement and logistical costs

Our service

- Procurement of all components and foreign parts



- Control cabinets made to measure
- Individually configured
- Adapted to requirements in industrial automation
- Design and sizing included

Festo made-to-measure control cabinets provide protection for all pneumatic, electrical and electronic system components.

The control cabinets are individually

designed and built for the respective application, taking into account specific industry requirements such as those in the food or automotive industries, for example. The design is also influenced by

local conditions such as weather and climate.

Along with Festo components, third-party components are integrated into the control cabinets as required.

The operationally tested system is delivered ready-to-install – directly to where it will be used, if requested.

Technical data

- Simple to complex control cabinet designs
 - Pneumatic
 - Electrical
 - Combined
- Application-specific combination of components
- Use of the latest innovations and technologies
- Fully tested, with test certificate
- Ready-to-install
- Complete documentation

- Design conforms to:
 - EN 60204-1
 - ATEX zone 1 and 21 (pneumatic only), ATEX zone 2 and 22 (electric and electro-pneumatic)
 - UL-508A
- Implementation of safety functions

- Different bus technologies:
 - PROFIBUS
 - PROFIBUS DP
 - PROFIBUS PA
 - PROFIBUS FMS
 - PROFINET
 - INTERBUS
 - EtherCAT
 - CANopen
 - MODBUS
 - DeviceNet
 - EtherNet/IP
 - CC-Link
 - AS-Interface

Ready-to-install – the benefits to you

Ordering

Just one order number for the entire control cabinet.

Engineering

Complete engineering solution according to your application-specific requirements by Festo specialists.

Production & assembly

The entire production and assembly process is taken care of for you.

Checking & testing

The control cabinet is fully tested.

Documentation

You receive detailed system documentation, which you can quickly and easily integrate into your overall documentation:

- Assembly drawing
- Bill of materials
- Circuit diagrams (EPLAN/Promis)
- Operating instructions for components

Interested in control cabinets for factory automation?

Ask your Festo sales engineer, who will be happy to help.

Or visit your local website at www.festo.com,

where you will find further information on ready-to-install solutions.

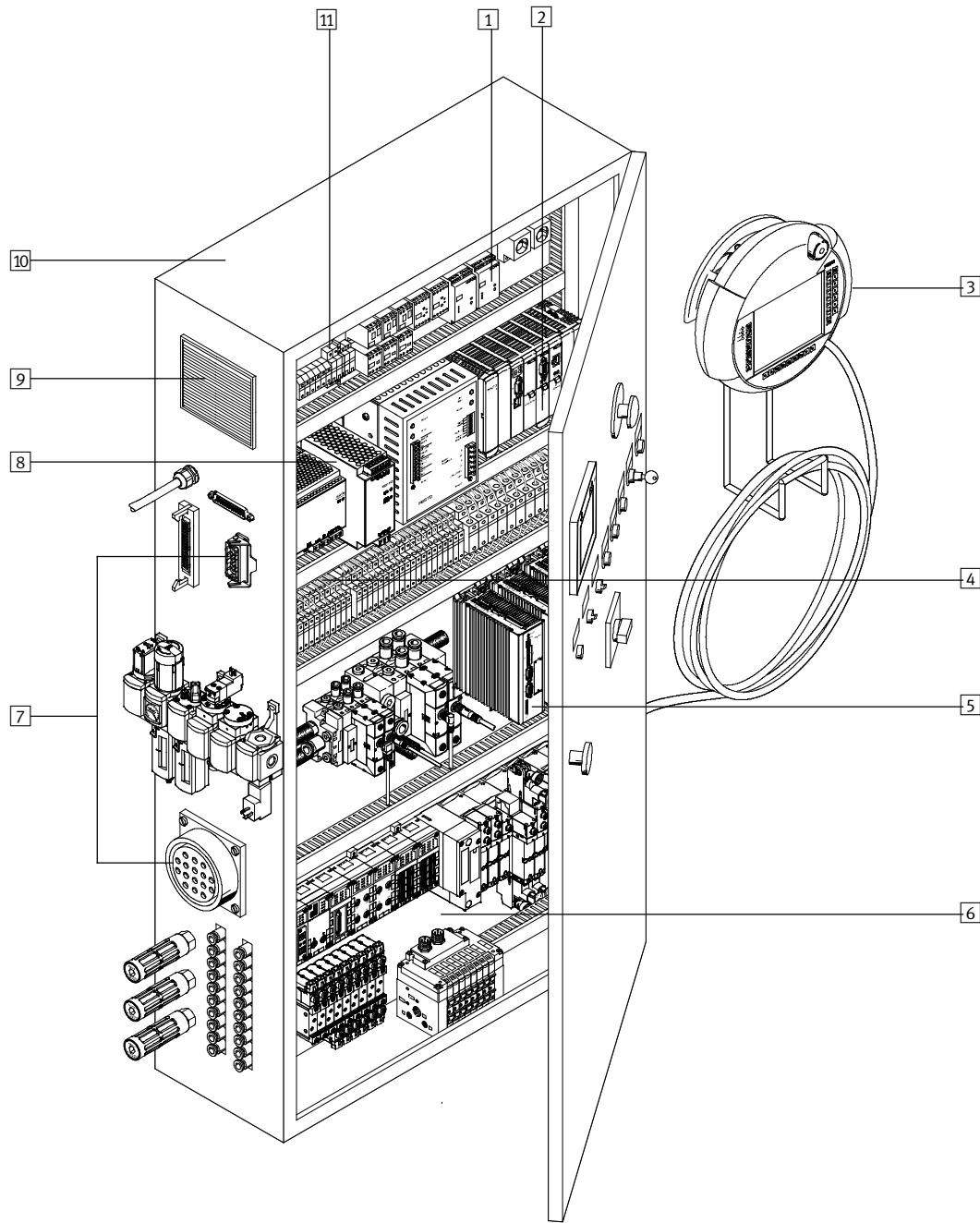

- | | | | |
|---|---|--|--|
| <p>1 Power supply</p> <ul style="list-style-type: none"> - 24 V DC, up to 20 A - 48 V DC - Single-phase/three-phase - Plug sockets <p>2 Control system</p> <ul style="list-style-type: none"> - CMXR, CECX, FED, CPX - Robot control system - Third-party control systems - Up to 6 axes - Safety relays <p>3 Operator units</p> <ul style="list-style-type: none"> - Mobile: MMI, CDSA - Integration in the control cabinet: emergency off, key actuator, control elements | <p>4 Wiring/tubing</p> <ul style="list-style-type: none"> - Number of wires - Cross section - Cable harness/individual cables - Cable inscription - Tubing diameter - Tubing colour/material - Tubing designation <p>5 Controller</p> <ul style="list-style-type: none"> - Servo motor - Stepper motor - DC motor | <p>6 Pneumatics</p> <ul style="list-style-type: none"> - Valves/valve terminals - Compressed air preparation - Pressure regulators - Sensors - Servopneumatics <p>7 Outputs</p> <ul style="list-style-type: none"> - Pneumatic, electrical - Multi-pin interfaces <p>8 Power supply unit</p> <ul style="list-style-type: none"> - Converts AC voltage/frequency - Speed regulation | <p>9 Cooling/heating</p> <ul style="list-style-type: none"> - Active - Passive <p>10 Housing</p> <ul style="list-style-type: none"> - Sheet steel/stainless steel/ aluminium/plastic - Standard sizes - Special sizes - Illuminated - Control cabinet colour RAL 7035 or special colour - Labels <p>11 Fuses</p> <ul style="list-style-type: none"> - Safety fuse - Circuit breaker |
|---|---|--|--|

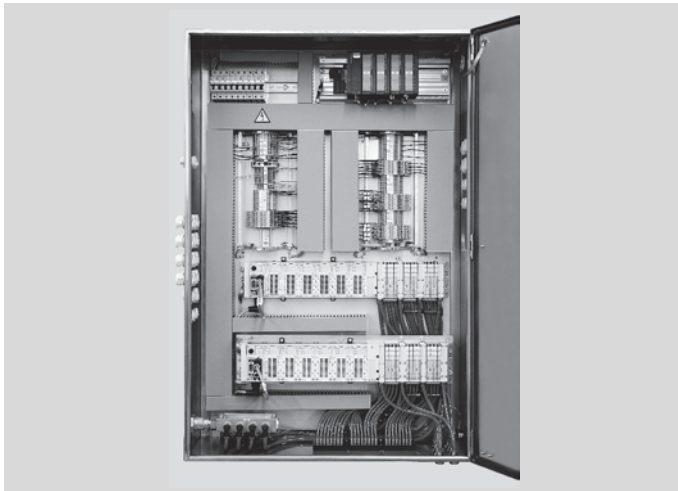

- Control cabinets made to measure
- Individually configured
- Adapted to requirements in process automation
- Design and sizing included

Festo made-to-measure control cabinets provide protection for all pneumatic, electrical and electronic system components.

The control cabinets are individually

designed and built for the respective application, taking into account specific process industry requirements. The design is also influenced by local conditions such as weather and climate as well

as compliance with hygiene criteria or protection classes.

Along with Festo components, third-party components are integrated into the

control cabinets as required.

The operationally tested system is delivered ready-to-install – directly to where it will be used, if requested.

Technical data

- Simple to complex control cabinet designs
 - Pneumatic
 - Electrical
 - Combined
- Application-specific combination of components
- Different operating voltages possible
- Use of the latest innovations and technologies
- Fully tested, with test certificate
- Ready-to-install
- Complete documentation
- Design conforms to:
 - EN 60204-1
 - ATEX zone 1 and 21 (pneumatic only), ATEX zone 2 and 22 (electric and electro-pneumatic)
 - UL-508A

- Implementation of safety functions
- Wide range of bus technologies
- Compliance with special cleanliness and hygiene requirements
- Special materials, e.g. stainless steel, for use in virtually all ambient conditions
- Protected against the ingress of liquids and foreign matter
- Installation of heating or cooling elements
- Intrinsically safe valve terminal technology

- Replacement of individual terminal valves during operation (hot swap)
- Installation of inspection windows
- Control elements on the outside
- Safe thanks to key lock system on the service unit: to switch off, all employees responsible must remove their lock

Ready-to-install – the benefits to you

Ordering

Just one order number for the entire control cabinet.

Engineering

Complete engineering solution according to your application-specific requirements by Festo specialists.

Production & assembly

The entire production and assembly process is taken care of for you.

Checking & testing

The control cabinet is fully tested.

Documentation

You receive detailed system documentation, which you can quickly and easily integrate into your overall documentation:

- Assembly drawing
- Bill of materials
- Circuit diagrams (EPLAN/Promis)
- Operating instructions for components

Interested in control cabinets for process automation?

Ask your Festo sales engineer, who will be happy to help.

Or visit your local website at www.festo.com,

where you will find further information on ready-to-install solutions.

Control cabinets for controllers

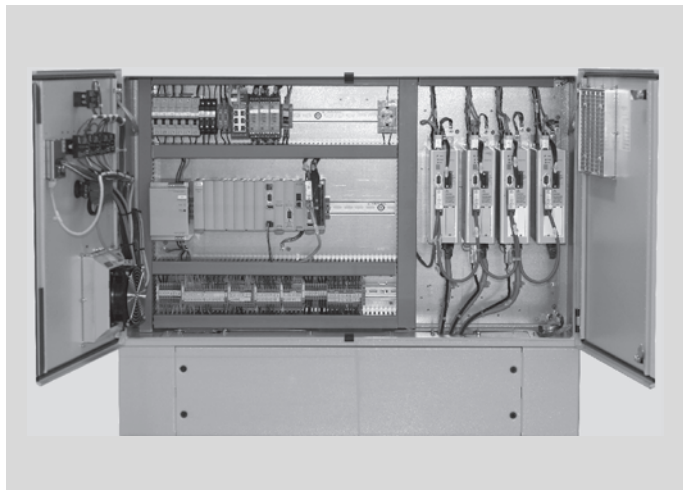

- Made-to-measure control cabinets for handling systems
- Software package for third-party devices included
- Individually configurable
- Adapted to requirements for handling solutions → 504

Festo made-to-measure control cabinets for controllers provide protection for control components for single-axis and multi-axis systems, from solutions involving simple control tasks to the

complex control of highly dynamic movements, such as with the tripod. The control cabinets are individually designed and built for the respective application, taking into account specific

industry requirements such as those in the food or pharmaceuticals industries, for example. Festo can also integrate third-party components, including software packages, as

required. The operationally tested system is delivered ready-to-install – directly to where it will be used, if requested.

Technical data

- Simple to complex control cabinet designs
- 1 ... 31 axes
- Application-specific combination of components
- Use of the latest innovations and technologies

- Fully tested, with test certificate
- Ready-to-install
- Complete documentation
- Design conforms to:
 - EN 60204-1
 - ATEX zone 1 and 21 (pneumatic only), ATEX zone 2 and 22 (electric and electro-pneumatic)
 - UL-508A

- Implementation of safety functions
- Wide range of bus technologies

Ready-to-install – the benefits to you

Everything from a single source
Handling system and control cabinet perfectly co-ordinated.

Ordering
Just one order number for the entire control cabinet.

Engineering
Complete engineering solution according to your application-specific requirements by Festo specialists.

Production & assembly
The entire production and assembly process is taken care of for you.

Checking & testing
The control cabinet is fully tested.

Documentation
You receive detailed system documentation, which you can quickly and easily integrate into your overall documentation:

- Assembly drawing
- Bill of materials
- Circuit diagrams (EPLAN/Promis)
- Operating instructions for components

Interested in control cabinets for controllers?

Ask your Festo sales engineer, who will be happy to help.

Or visit your local website at www.festo.com,

where you will find further information on ready-to-install solutions.

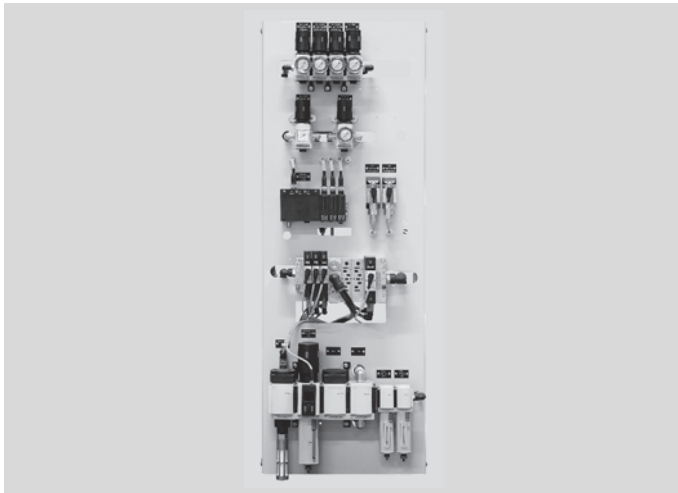

- Machine-specific pre-assembly of pneumatic and electrical components on support plate
- Tubing and wiring included
- Defined interfaces for simple installation directly in the system

Festo mounting plates are used for the function-specific pre-assembly of pneumatic and electrical components. They support the individual components and are integrated directly into the system concept.

Each mounting plate has a customised design based on the respective application and with a customised combination of components. In addition to Festo components, third-party components can be

integrated as required.

The mounting plate is supplied ready-to-install – fully connected and tested. It can be installed directly in the machine. Suitable mounting attachments are

already fitted to or integrated into the support plate. The pneumatic and electrical connections are also provided. These simply have to be connected to the machine.

Technical data

- Customised support plate shape
- For a wide range of industrial applications
- Support plate available in different materials, e.g. sheet steel, stainless steel, etc.
- Application-specific combination of components
- Fully assembled, connected and wired

- Defined interfaces
- Use of the latest innovations and technologies
- Ready-to-install:
All steps from engineering and assembly to quality inspection are carried out by Festo specialists
- Fully tested, with test certificate
- Complete documentation

- Design conforms to:
 - EN 60204-1
 - ATEX zone 1 and 21 (pneumatic only), ATEX zone 2 and 22 (electric and electro-pneumatic)
 - UL-508A
- Implementation of safety functions

Ready-to-install – the benefits to you

Ordering

Just one order number for the entire solution.

Engineering

Complete engineering solution according to your application-specific requirements by Festo specialists.

Production & assembly

The mounting plate is ready-to-install. The entire assembly process, including wiring and connection, is thus taken care of for you.

Documentation

You receive detailed system documentation, which you can quickly and easily integrate into your overall documentation:

- Assembly drawing
- Bill of materials
- Circuit diagrams
- Operating instructions for components

Interested in mounting plates?

Ask your Festo sales engineer, who will be happy to help.

Or visit your local website at www.festo.com,

where you will find further information on ready-to-install solutions.

Mounting plates

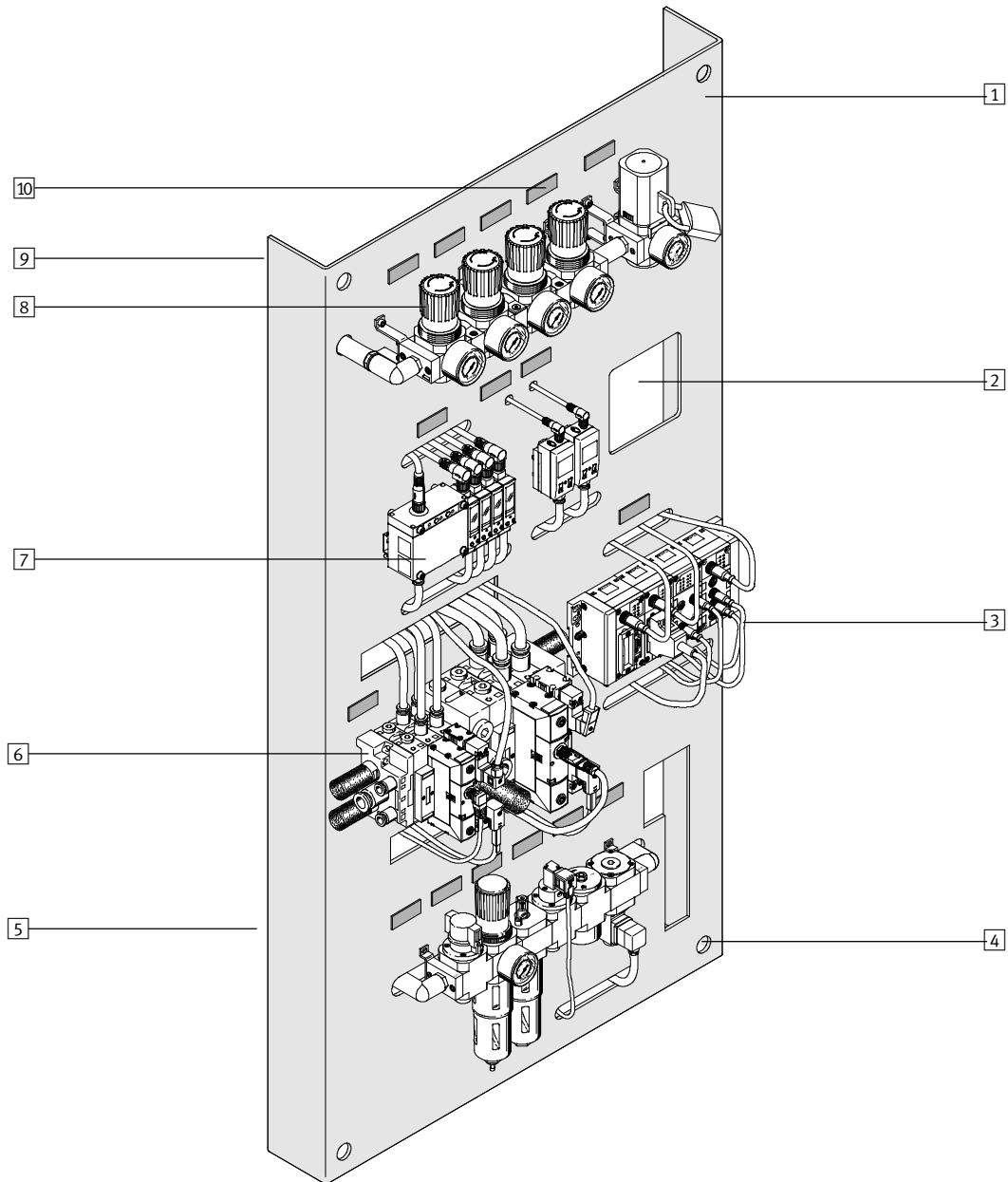

- | | | | |
|---|---|--|--|
| <p>1 Support plate</p> <ul style="list-style-type: none"> - Sheet steel/stainless steel/ aluminium/plastic - Individually adapted shape and size - Plate is integrated directly into the machine concept as a supporting component - Labelling | <p>2 Cut-outs</p> <ul style="list-style-type: none"> - For tubing - For connections - etc. <p>3 Wiring/tubing</p> <ul style="list-style-type: none"> - Number of wires - Cross section - Cable harness/individual cables - Cable inscription | <p>4 Mounting options</p> <ul style="list-style-type: none"> - For mounting in the system <p>5 Electrical installation</p> <ul style="list-style-type: none"> - Implementation of electrical circuit diagrams in a solution (not shown) <p>6 Valves and valve terminals</p> <p>7 Sensors</p> <ul style="list-style-type: none"> - Pressure - Flow rate - Position | <p>8 Compressed air preparation</p> <ul style="list-style-type: none"> - MS series - D series - Customised configuration of modules <p>9 Defined interfaces for the machine</p> <ul style="list-style-type: none"> - Tubing/cables in specified length - Customised coupling - etc. <p>10 Customised inscriptions</p> |
|---|---|--|--|

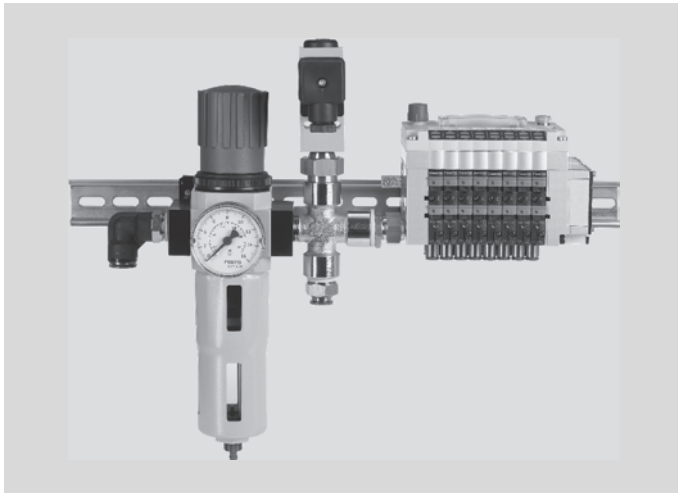

- Pneumatic and electrical components pre-assembled to create a function unit
- Can be combined from around 30,000 catalogue components
- Connections included
- For integration in machines

The product range from Festo comprises about 30,000 individual components, which can be pre-assembled to form a functional module. Accessories such as fittings and connections can also be assembled on the unit. The sub-assembly

can thus be installed directly in the system or in the higher-level system as a ready-to-install subsystem. A sub-assembly can be made up of a wide range of components. Typical combinations include:

- Cylinder/valve combinations
 - Components for compressed air preparation combined with valves
 - Valve manifolds
- Third-party components can be integrated and the sub-assembly can be mounted on a plate as required.

A complete functional test of the entire unit is carried out after completion. The sub-assembly is supplied ready-to-install.

Technical data

- Combination of various pneumatic and/or electrical components to create a single unit
- For a wide range of industrial applications
- Application-specific combination of components
- Optional: Accessories mounted on sub-assembly
- Use of the latest innovations and technologies

- Ready-to-install:
 - All steps from engineering and assembly to quality inspection are carried out by Festo specialists
- Fully tested, with test certificate
- Complete documentation

- Design conforms to:
 - EN 60204-1
 - ATEX zone 1 and 21 (pneumatic only), ATEX zone 2 and 22 (electric and electro-pneumatic)
 - UL-508A
- Implementation of safety functions

Ready-to-install – the benefits to you

Ordering

Just one order number for the entire solution.

Production & assembly

The entire production and assembly process, including wiring and connection, is taken care of for you. Connections to the system can be pre-installed on the sub-assembly if required.

Checking & testing

The sub-assembly is fully tested.

Documentation

You receive detailed system documentation, which you can quickly and easily integrate into your overall documentation:

- Assembly drawing
- Bill of materials
- Circuit diagrams
- Operating instructions for components

Interested in sub-assemblies?

Ask your Festo sales engineer, who will be happy to help.

Or visit your local website at www.festo.com,

where you will find further information on ready-to-install solutions.

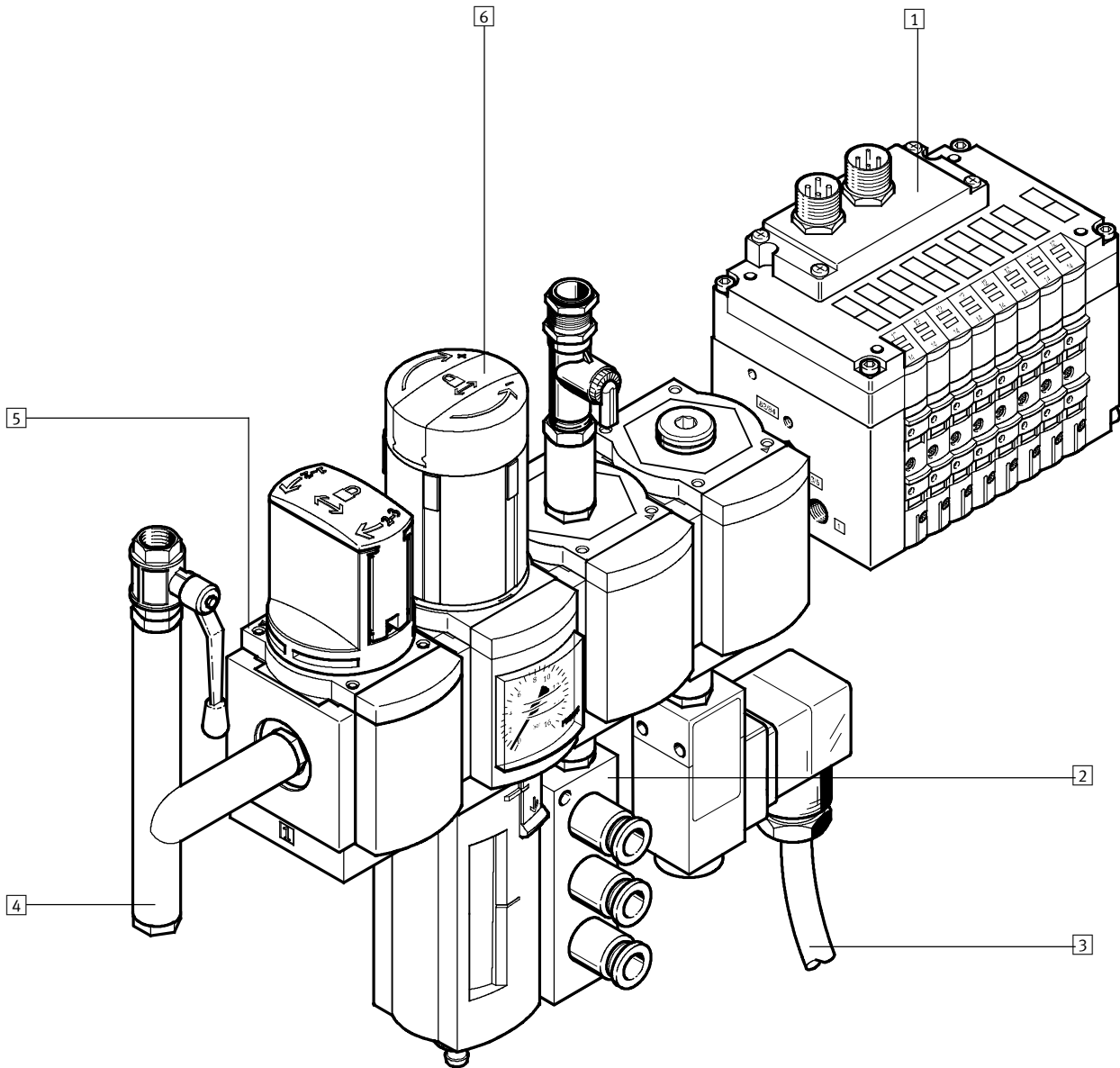

- 1** Valves and valve terminals
- 2** Other pneumatic components
 - Cylinders
 - Pressure regulators
 - Pressure gauges
 - Third-party components
 - Connections
 - Sensors
 - Servopneumatics
 - etc.

- 3** Tubing, wiring and piping
 - Number of wires
 - Cross section
 - Cable harness/individual cables
 - Cable inscription

- 4** Outputs
 - Pneumatic
 - Electrical
 - Multi-pin interfaces
- 5** Mounting options
 - For mounting in the system

- 6** Compressed air preparation
 - MS series
 - D series
 - Customised configuration of modules

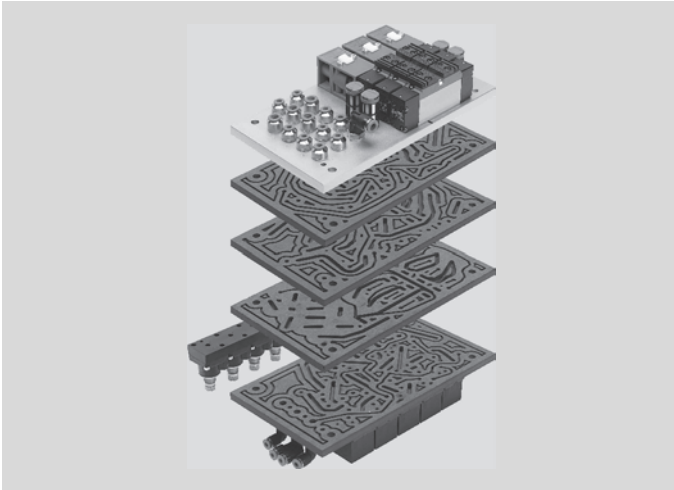

- Ideal for a large number of pneumatic connections in an extremely compact space
- No tubing
- Compact
- Easy to service
- Immune to malfunction

Manifold duct plates are used primarily in applications that demand a large number of pneumatic connections in a very small space.

Festo manifold duct plates made from polyurethane structural foam make conventional individual tubing completely

superfluous. Instead, they route the air to the individual components using defined ducts.

The omission of the tubing means that components can be positioned in the smallest of spaces. This means that screws, mountings attachments, etc.

remain easily accessible and ensures ease of servicing and maintenance.

The shape of the plate is freely selectable – depending on the space available. The interfaces can also be freely positioned. Aligned and glued in sandwich design, the entire block is extremely sturdy and

absolutely leak-proof thanks to multi-layer technology. It is the ideal solution for a high level of protection and is not subject to malfunction.

Technical data

- Freely selectable manifold duct plate shape
- Combination of over 30,000 catalogue components, e.g. valves, regulators, filters, sensors, etc.
- High density of components
- No tubing

- Variable positioning of mechanical, pneumatic and electrical interfaces
- Integration of customised components
- Compact
- Sturdy and immune to malfunction
- Sealed and protected unit

- Easy to service
- Available with protective cover
- Fully tested
- Ready-to-install
- Complete documentation
- Implementation of safety functions

Ready-to-install – the benefits to you

Ordering

Just one order number for the entire solution.

Engineering

Complete engineering solution according to your application-specific requirements by Festo specialists.

Production & assembly

The entire production and assembly process is taken care of for you.

Checking & testing

The solution is fully tested.

Documentation

You receive detailed system documentation, which you can quickly and easily integrate into your overall documentation.

Interested in manifold duct plates?

Ask your Festo sales engineer, who will be happy to help.

Or visit your local website at www.festo.com,

where you will find further information on ready-to-install solutions.

Manifold duct plates

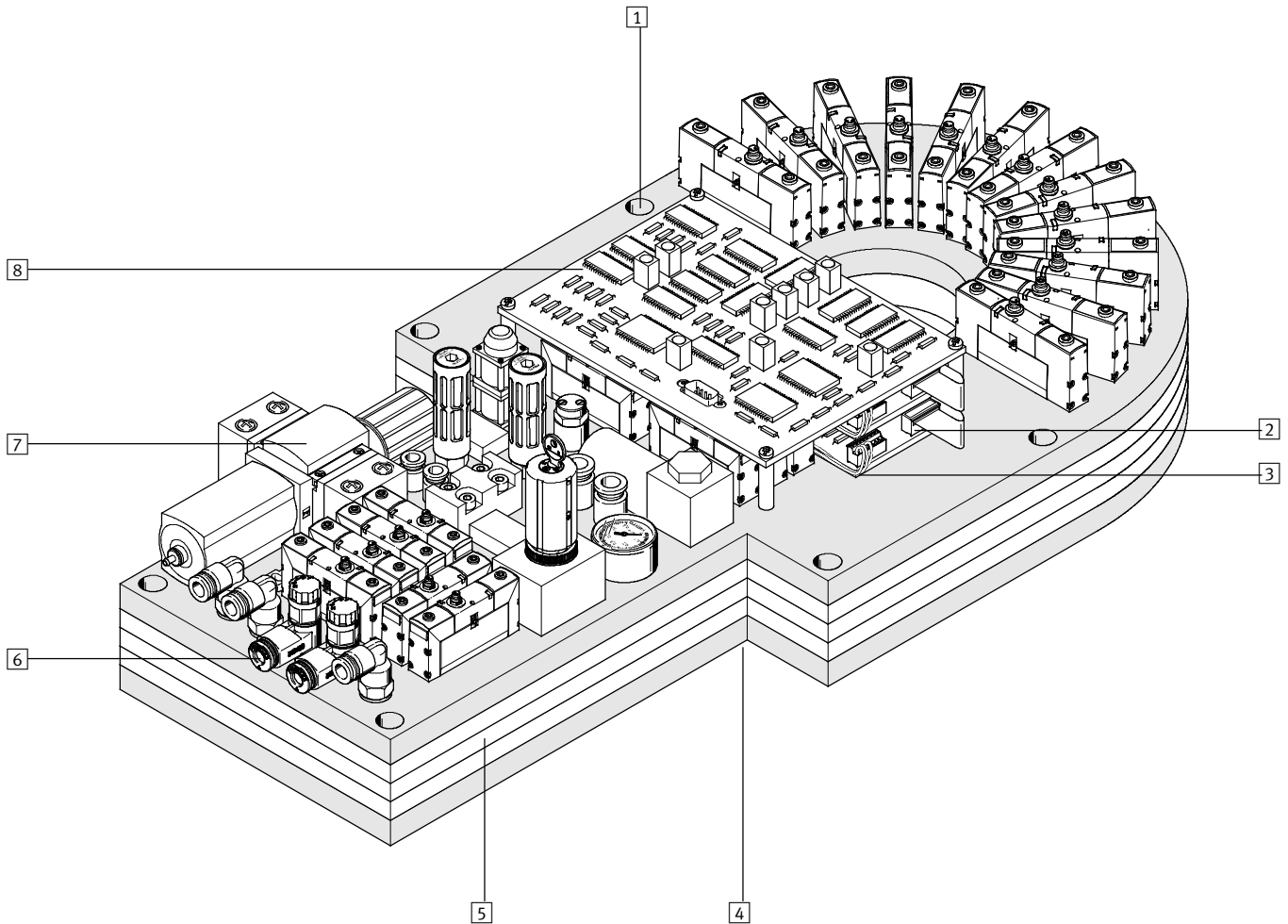

- | | | | |
|---|--|---|--|
| <p>1 Mounting options</p> <ul style="list-style-type: none"> - For mounting in the system <p>2 Electrical installation</p> <ul style="list-style-type: none"> - Cabling - PCBs <p>3 Sensors</p> <ul style="list-style-type: none"> - Pressure - Flow rate - Position | <p>4 Customised shape</p> <ul style="list-style-type: none"> - For precise integration in the system <p>5 Manifold duct plates</p> <ul style="list-style-type: none"> - Made from polyurethane structural foam - Variable number depending on the number of air ducts | <p>6 Outputs</p> <ul style="list-style-type: none"> - Freely selectable positioning - Pneumatic, electrical - Multi-pin interfaces <p>7 Pneumatics</p> <ul style="list-style-type: none"> - Compressed air preparation - Valves - Valve terminals - Pressure regulators - Pressure gauges - Third-party components | <p>8 Electronics</p> <ul style="list-style-type: none"> - Customised - Integrated or developed by Festo |
|---|--|---|--|

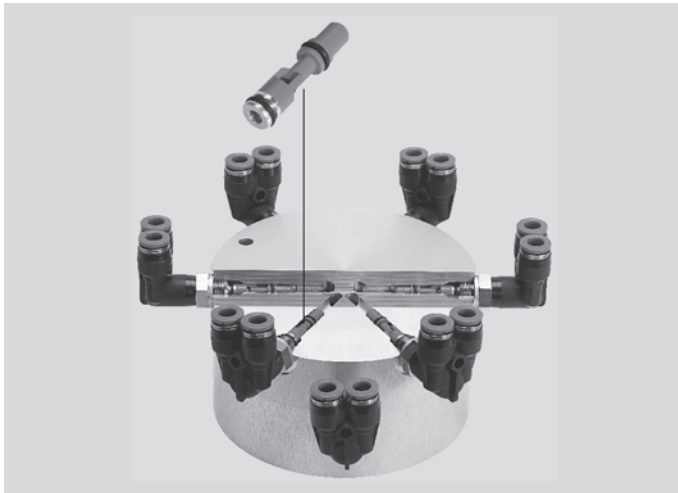

- Integration of various pneumatic functions in one component
- No need for single housings
- Ideal for applications that require a highly compact design

Cartridge solutions integrate one or more pneumatic functions in a closed unit. There is no need for individual housings, as the "insides" of the parts are housed in the component itself. Festo cartridge solutions are used

wherever an extremely compact design and component protection are required – with just a small number of pneumatic functions. Functionality provided by standard technology, such as directional control valves

or flow control valves, is fully integrated into the housing, thus reducing the required installation space. The housing has a customised design based on specific application requirements, which means that the cartridge

solution can be attached or installed just about anywhere on the machine.

Technical data

- Space-saving thanks to extremely compact design
- Pneumatic functions integrated in a single compact housing, e.g.:
 - Directional control valves
 - Flow control valves
 - Non-return valves
 - Vacuum generators
 - Pressure regulators
 - Pneumatic logic functions

- Housing available in different materials
- No tubing required
- Minimal cabling required
- Significant design freedom
- Variable integration options on and within the machine
- Sturdy design thanks to protected installed parts and smooth surfaces

- Fully tested
- Ready-to-install
- Complete documentation

Ready-to-install – the benefits to you

Engineering

Complete engineering solution according to your application-specific requirements by Festo specialists.

Production & assembly

The entire production and assembly process is taken care of for you.

Documentation

You receive detailed system documentation, which you can quickly and easily integrate into your overall documentation.

Checking & testing

The solution is fully tested.

Interested in cartridge solutions?

Ask your Festo sales engineer, who will be happy to help.

Or visit your local website at www.festo.com,

where you will find further information on ready-to-install solutions.

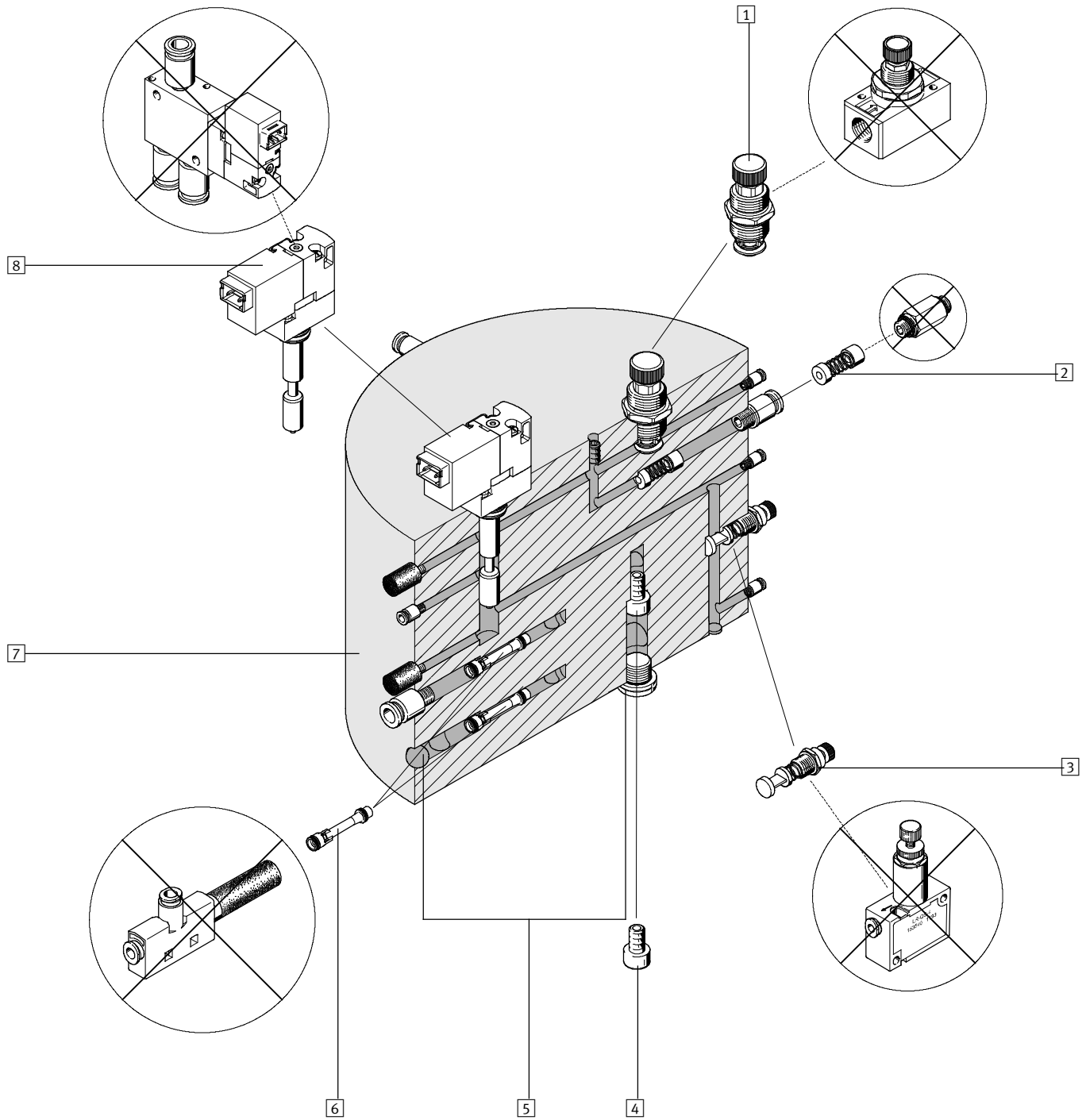

- 1** Flow control valve
– Integrated
- 2** Non-return valve
– Integrated
- 3** Pressure regulator
– Integrated

- 4** Fixed restrictor
– Screw-in
- 5** Sealing of holes
– Integrated
- 6** Vacuum generator
– Integrated
– Various sizes

- 7** Housing
– Aluminium
– Brass
– Steel
– POM
– PEEK
– PA
– etc.

- 8** Valve
– Integrated

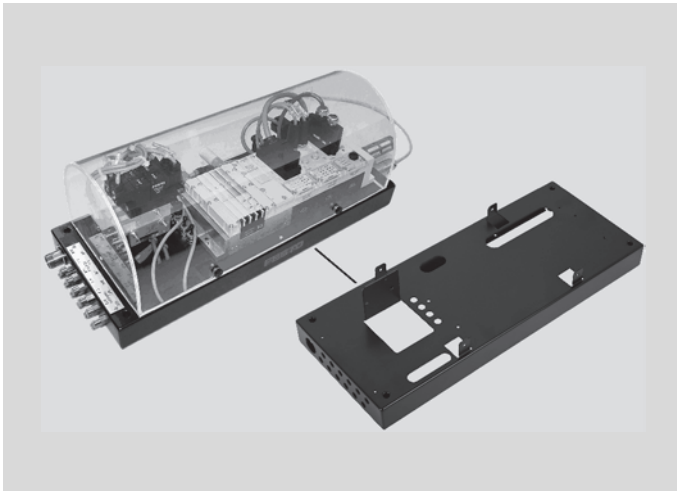

- Reduced weight thanks to optimal use of materials with sheet-metal constructions
- Protection against environmental influences and unauthorised access
- Ideally combined as a control cabinet directly in the system

A sheet-metal construction acts as a support for pneumatic and electrical components. The well thought-out design makes it possible to get the most out of the material used. Upright steel parts perform the function of mounting

brackets in this case. This means fewer components and reduced weight, making the entire system into a compact unit. Special housings protect electrical and pneumatic components against environmental influences and unauthorised

access. They also lend applications a more attractive appearance. They are developed for specific applications in a space-saving design. When combined, sheet-metal constructions and special housings produce a

small control cabinet, which can be fitted directly in or on the application. The short tubing and cable lengths achieved result in significantly reduced switching times.

Technical data

- Sheet-metal constructions
 - Customised shape and size
 - Reduced weight and number of assembly parts

- Special housing
 - Customised shape (flat, curved, rectangular, etc.)
 - Customised dimensions
 - Different materials (metal, aluminium, plastic, etc.)
 - Compact, space-saving format
 - Protection against environmental influences and unauthorised access

- In combination
 - Alternative to conventional control cabinets
 - Variable integration options on and within the machine
 - Short tubing and cable lengths
 - Attractive design

Ready-to-install – the benefits to you

Engineering

Complete engineering solution according to your application-specific requirements by Festo specialists.

Production & assembly

The entire production and assembly process is taken care of for you.

Checking & testing

The solution is fully tested.

Documentation

You receive detailed system documentation, which you can quickly and easily integrate into your overall documentation.

Interested in sheet-metal constructions and special housings?

Ask your Festo sales engineer, who will be happy to help.

Or visit your local website at www.festo.com,

where you will find further information on ready-to-install solutions.

Sheet-metal constructions and special housings

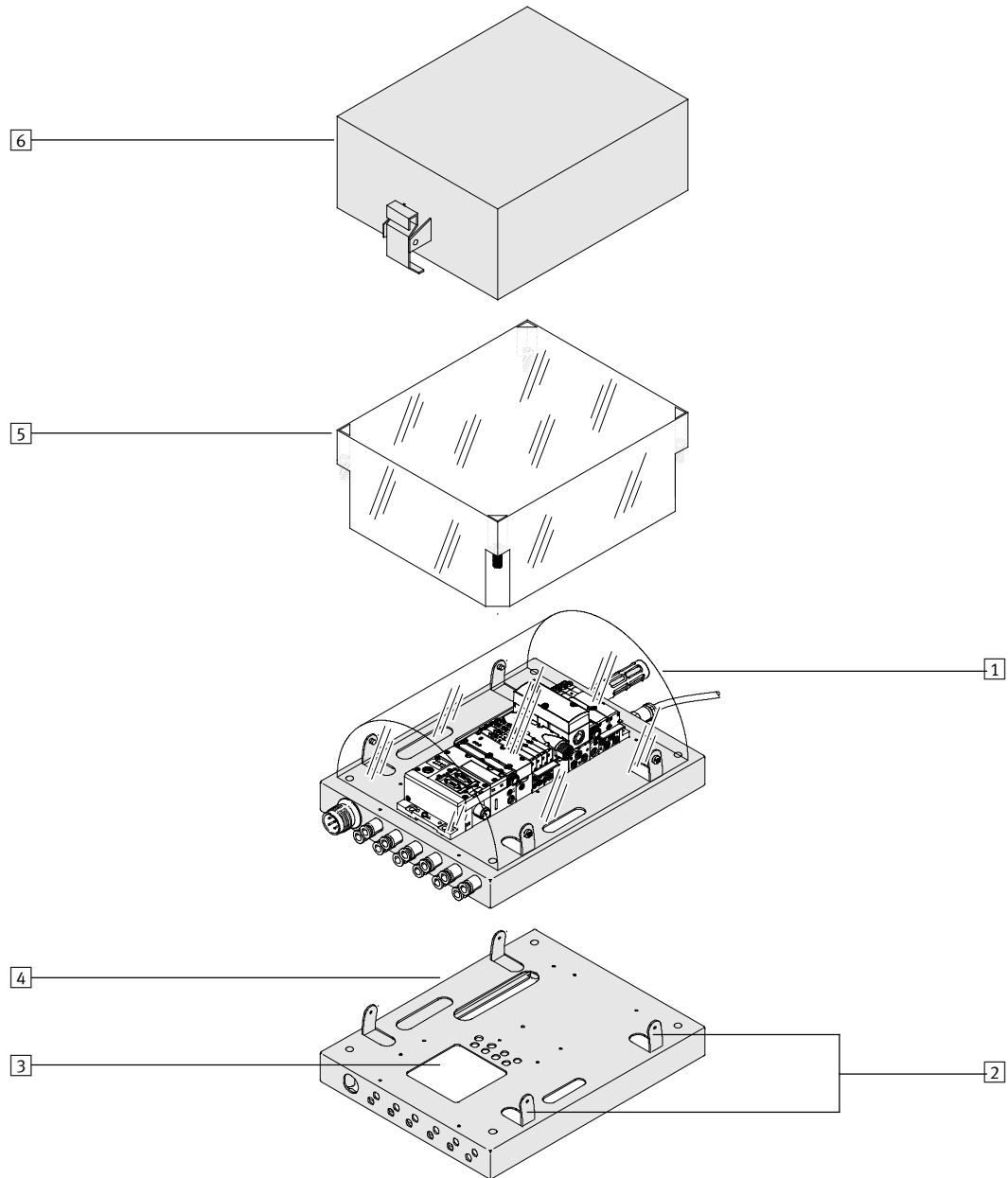

- 1** One basic solution
 - Small control cabinet
- 2** Upright sheet-metal parts
 - As mounting brackets
- 3** Cut-outs
 - For tubing
 - For connections
 - etc.
- 4** Sheet-metal construction
 - Customised dimensions
 - Customised shapes
- 5** Material
 - Metal
 - Plastic
 - etc.
- 6** Special housing
 - Customised dimensions
 - Customised shapes (flat, curved etc.)

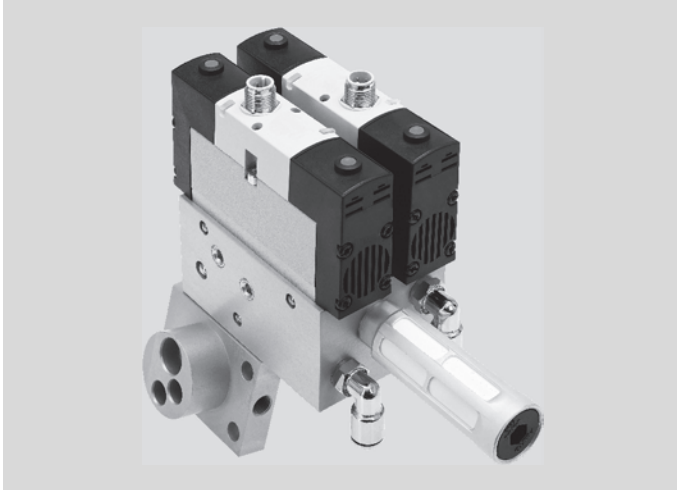

- Compressed air supply for pneumatic components via drilled ducts
- Ideal for small number of pneumatic components and variable connection options
- Compact and easy to service

For applications that require the installation of only a small number of pneumatic components in a compact space, Festo function blocks with drilled ducts

represent a practical alternative to manifold duct plates. The position of the connections must be variable and not subject to any special requirements.

In the function block, the air supply connections are established using intersecting ducts – individual sub-bases are no longer required. The components are

mounted directly on the function block, which means that no tubing is required.

Technical data

- No tubing required thanks to drilled ducts
- Housing available in different materials:
 - Aluminium
 - Brass
 - Steel
 - POM
 - PEEK
 - PA
 - etc.

- Customised design of the pneumatic interfaces for the system
- Ideal for a small number of components and variable connection options

- Extremely economical, even for small quantities

Ready-to-install – the benefits to you

Engineering

Complete engineering solution according to your application-specific requirements by Festo specialists.

Production & assembly

The entire production and assembly process is taken care of for you.

Documentation

You receive detailed system documentation, which you can quickly and easily integrate into your overall documentation.

Checking & testing

The solution is fully tested.

Interested in function blocks?

Ask your Festo sales engineer, who will be happy to help.

Or visit your local website at www.festo.com,

where you will find further information on ready-to-install solutions.

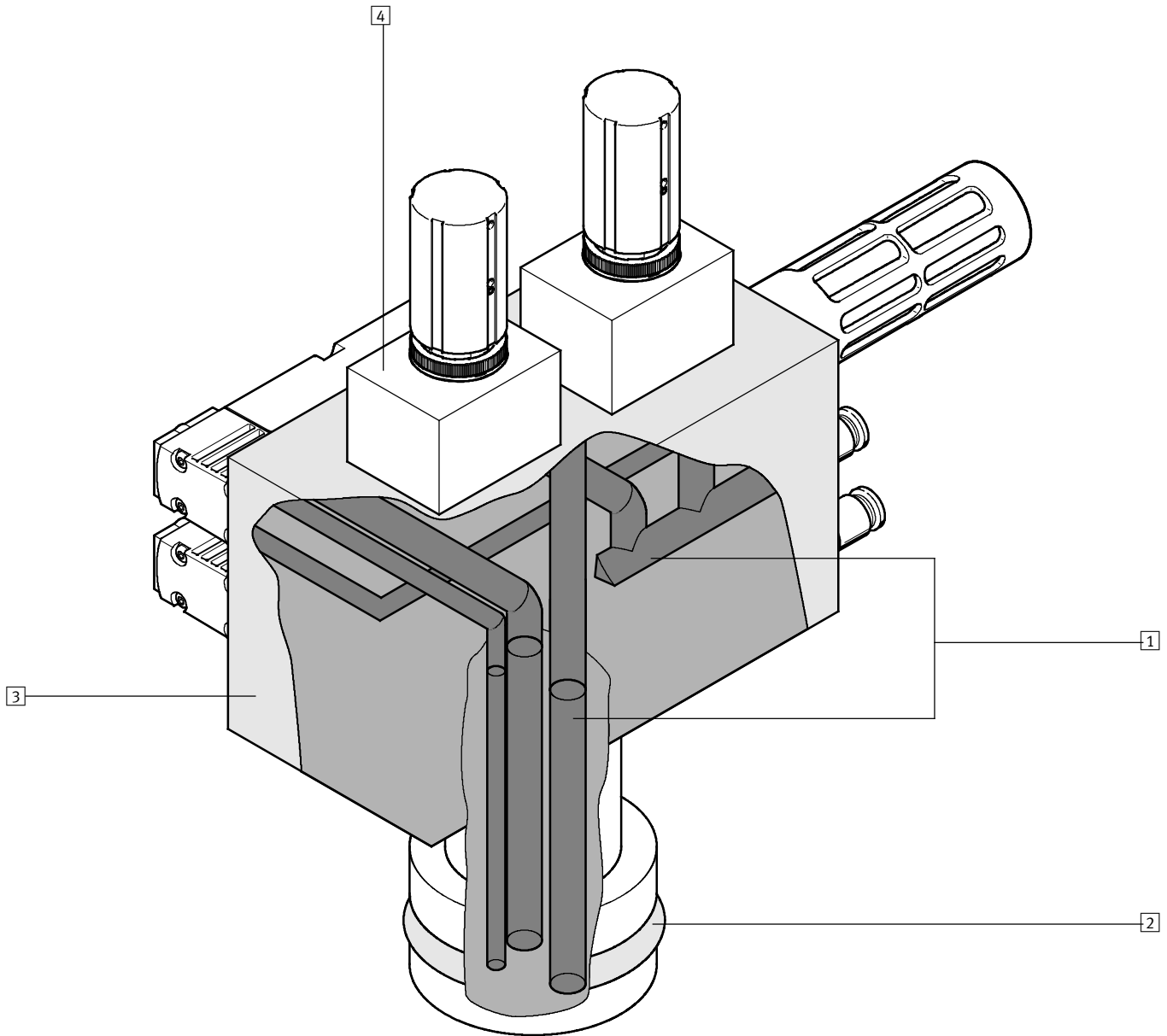

1 Drilled ducts
– For the air supply

2 Pneumatic interfaces for the machine
– Customised

3 Housing
– Aluminium
– Brass
– Steel
– POM
– PEEK
– PA
– etc.

4 Pneumatics
– Compressed air preparation
– Valves
– Valve terminals
– Pressure regulators
– Pressure gauges
– Third-party components
– Connections

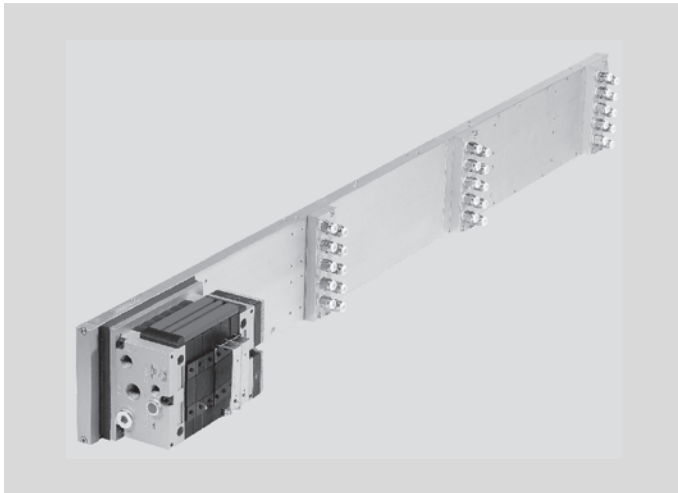

- Extruded profiles in combination with valves as a valve terminal
- For the distribution of compressed air in the machine concept
- Customised profile cross sections available

Profile solutions enable valve terminal concepts to be adapted to the machine design. Space optimisation, high performance in a small space and optimal distribution of compressed air within the

system are just some of the main advantages. The compressed air flows into integrated ducts. Exhaust air and supply air can thus be combined over long distances

without any tubing. The compressed air is then provided at different locations according to specific requirements. Festo profiles have different cross

sections and lengths depending on application requirements. The valves and valve terminals can be mounted on the profile in a freely definable grid.

Technical data

- Profiles in customised cross sections and lengths
- Integrated ducts for straight-line routing of the compressed air
- Common air supply for multiple valves or valve terminals via a single duct

- Combination of exhaust air and supply air without tubing, even over long distances
- Supply of compressed air at different locations
- No tubing required

- Significantly reduced cabling
- Modular structure easy to achieve
- Optional: profile as mechanical mounting element for other components or as a supporting part of the machine frame

Ready-to-install – the benefits to you

Engineering

Complete engineering solution according to your application-specific requirements by Festo specialists.

Production & assembly

The entire production and assembly process is taken care of for you.

Documentation

You receive detailed system documentation, which you can quickly and easily integrate into your overall documentation.

Checking & testing

The solution is fully tested.

Interested in profile solutions?

Ask your Festo sales engineer, who will be happy to help.

Or visit your local website at www.festo.com,

where you will find further information on ready-to-install solutions.

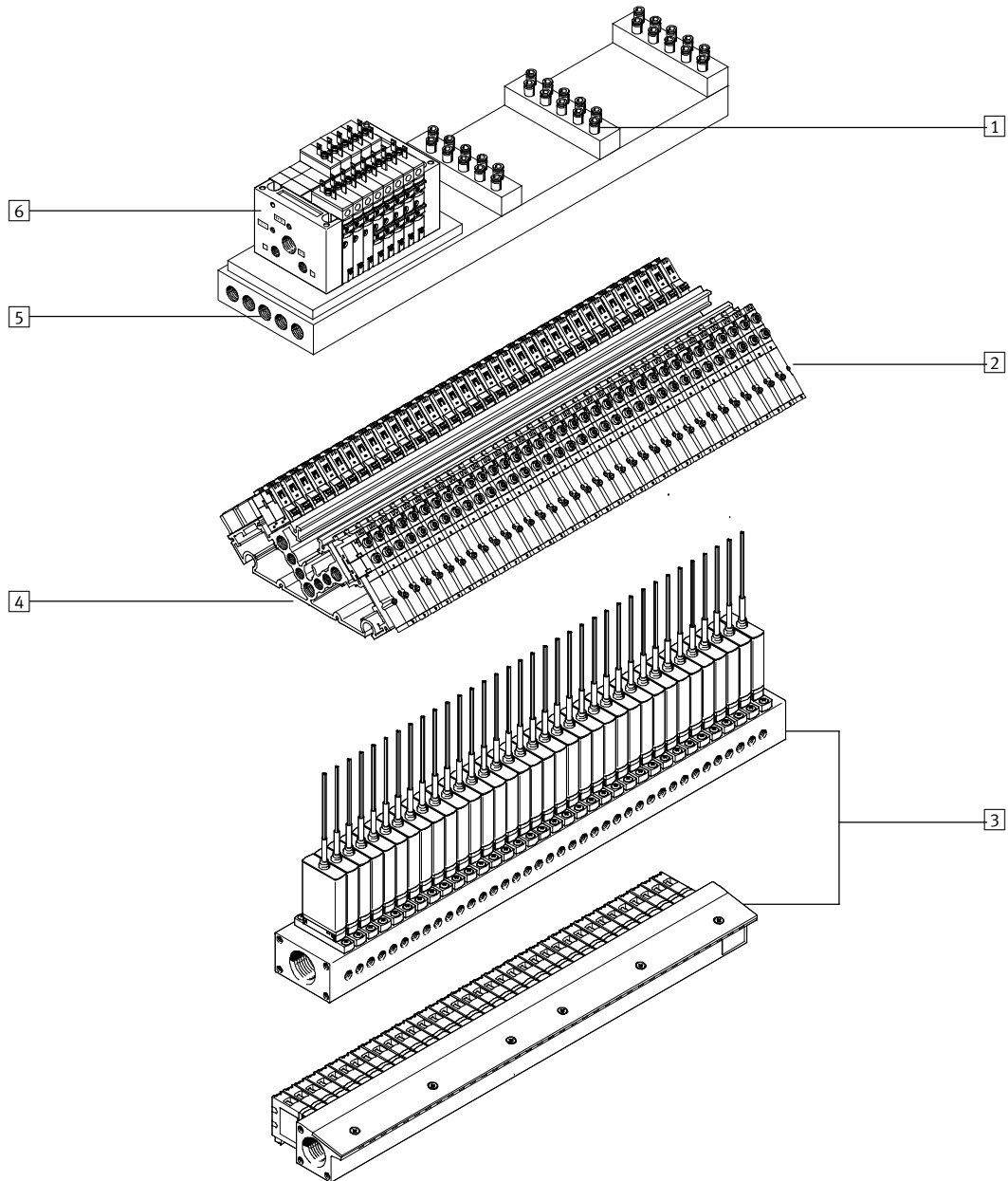

- 1** Air ducts
 - Supply of compressed air at different locations
- 2** Valves and valve terminals
 - Freely definable grid
 - Freely definable number

- 3** Customised pneumatic connection
 - Optimised for the machine concept



- 4** Extruded aluminium profile
 - Customised shape (round, square, trapezoidal, etc.)
 - Customised profile cross sections
 - Freely definable lengths

- 5** Air ducts
 - For the distribution of compressed air in the system
- 6** Valve terminals





18 Services



Operating phase

	 Maintenance	 Repair service
Services	Implementation of the following preventive maintenance measures to DIN 31051: <ul style="list-style-type: none"> • Inspections <ul style="list-style-type: none"> – Checking for damage and wear characteristics – Checking of mechanical, pneumatic and electrical connections and connectors – Checking of lubrication – Checking of compressed air preparation – Carrying out of component-specific inspections • Service <ul style="list-style-type: none"> – Lubrication/relubrication of guides – Tightening of connectors – Replacement of air filters – Replacement of silencers – Carrying out of component-specific preventive maintenance tasks • Repair <ul style="list-style-type: none"> – Troubleshooting – Solution finding – Error elimination – Elimination of leakages – Replacement or repair of components 	<ul style="list-style-type: none"> • Inspection • Analysis of economic efficiency • Repair or replacement of faulty components or wearing parts • Leakage testing • Functional test Please send the faulty component and a detailed error description to your Festo national company. Detailed spare parts lists can be found on the Festo website.
Description	<ul style="list-style-type: none"> • Preventive and corrective maintenance • Directly on your system • For high machine availability and rapid assistance should the worst happen 	<ul style="list-style-type: none"> • Send high-quality components and assemblies to Festo for repair • Extended service life • Reduced costs
→ Page/online	1022	1023

Energy Saving Services

	 <p>Energy analysis of compressed air generation</p>	 <p>Compressed air consumption analysis</p>	 <p>Compressed air quality analysis</p>	 <p>Leakage detection</p>
<p>Services</p>	<ul style="list-style-type: none"> • Measurement of compressor operating times as well as load/idling times • Power consumption measurement • Flow measurement/consumption measurement • Pressure measurement (level and band width) • Estimation of leakage volume • Comparison of energy consumption and compressed air volume supplied 	<ul style="list-style-type: none"> • Installation and removal of the measuring equipment with standard components (fittings, tubing, etc.) • Measurement of flow rate, consumption and pressure with machine running and when idle • Determination and analysis of different characteristics <ul style="list-style-type: none"> – Consumption per machine cycle – Average consumption per minute – Average pressure – Max./min. pressure – Max./min. rate of air flow • Documentation of measurement results including graphical representation of measurement results, optionally available as PDF file or colour printout • 3 hours on-site service (additional time on request) 	<ul style="list-style-type: none"> • Inspection of decentralised air preparation at point of usage • Measurement of the residual oil content up to class 2 (ISO 8573-1:2010) • Measurement of the pressure dew point up to class 2 (ISO 8573-1:2010) • Analysis of measurement results and recommendation of improvement measures (if applicable) • Documentation of all measurement results • 3 hours on-site service (max. 3 measurements; additional time on request) 	<ul style="list-style-type: none"> • Detection of compressed air leakages using highly sensitive ultrasound detectors during operation • Checking of the complete compressed air system from the compressor to the pneumatic application • Classification of the leakages according to size and cost • Documentation of faulty components as well as of the type and cause of fault • Leakage report containing: <ul style="list-style-type: none"> – Recommended measures – Spare parts required – Estimation of repair time – Prioritisation of measures – Assessment as to whether repair can be carried out while machine is in operation • Information on optimisation options • Documentation of measures carried out
<p>Description</p>	<ul style="list-style-type: none"> • Energy Saving Services – the service package for energy efficiency • Identification and optimum utilisation of potential savings for compressed air • Save up to 60% on compressed air costs • Energy saving begins with the compressor 	<ul style="list-style-type: none"> • Determination of exact compressed air consumption • Optimal configuration of compressed air supply • No pressure drop due to undersupply • No unnecessary energy costs due to oversupply 	<ul style="list-style-type: none"> • Optimisation of compressed air quality • Increased service life of components • Reduction of maintenance costs 	<ul style="list-style-type: none"> • Detection and repair of leakages in production plants • Immediate energy and operating cost savings
<p>→ Page/online</p>	<p>1024</p>	<p>1026</p>	<p>1028</p>	<p>1030</p>

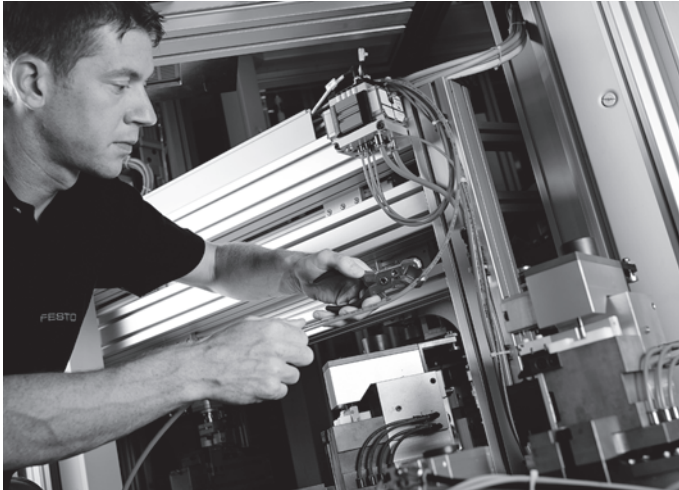

Complex automation technology increasingly requires specialist knowledge, whether it's for preventive maintenance or for troubleshooting with subsequent fault elimination.

Our qualified service technicians are specially trained for this task and have extensive automation expertise. They will come to your plant and assist you directly on-site at the machine.

- Preventive and corrective maintenance
- Directly at your system
- For high machine availability and rapid assistance should the worst happen

Objectives

- Optimal preventive maintenance of pneumatic and electrical automation components and systems
- Prevention of unplanned production downtime
- Fast and effective support in the event of malfunctions or production downtime
- Reduced energy consumption

Services

Implementation of the following preventive maintenance measures to DIN 31051:

Inspections

- Checking for damage and wear characteristics
- Checking of mechanical, pneumatic and electrical connections and connectors
- Checking of lubrication
- Checking of compressed air preparation
- Carrying out of component-specific inspections

Service

- Lubrication/relubrication of guides
- Tightening of connectors
- Replacement of air filters
- Replacement of silencers
- Carrying out of component-specific preventive maintenance tasks

Repair

- Troubleshooting
- Solution finding
- Error elimination
- Elimination of leakages
- Replacement or repair of components

The benefits to you

- Professional implementation of preventive maintenance measures for optimum machine operation by specialists from Festo
- Professional and fast support in the event of malfunctions and production downtime
- Reduced workload for your maintenance personnel
- Individual services available on request

Are you interested in this service?

Ask your Festo sales engineer, who will be happy to help.

Or visit your local website at www.festo.com,

to find out more about our services.



- Send high-quality components and assemblies to Festo for repair
- Extended service life
- Reduced costs

Replacing wearing parts is often a cost-effective way of extending the service life

of components and assemblies.

Objectives

- To extend the service life of high-quality components and assemblies cost-effectively.

Services

- Inspection
- Analysis of economic efficiency
- Repair or replacement of faulty components or wearing parts
- Leakage testing
- Functional test

Please send the faulty component and a detailed error description to your Festo national company.

Detailed spare parts lists can be found on the Festo Internet site.

The benefits to you

- Extended service life of components and assemblies
- Reduced maintenance costs

- High process security
- Reduced energy costs

- Also available in some countries as an Express Repair Service (e.g. repair within 2 hours) and at a fixed price

Are you interested in this service?

Ask your Festo sales engineer, who will be happy to help.

Or visit your local website at www.festo.com,

to find out more about our services.



- Energy efficiency is becoming an increasingly important factor when considering production plants. The majority of savings can be achieved in plant operation. This is where Energy Saving Services come in – delivering a customised service package for energy efficiency
- Identification and optimum utilisation of potential savings for compressed air
- Save up to 60% on compressed air costs
- Lower operating costs, higher machine availability and longer service life of components

The efficiency of a compressed air system begins with compressed air generation. Determining current energy and compressed air consumption provides the basis for being able to calculate and

assess current costs and potential savings. Possible optimisations can also be worked out.

Objectives

- Recording and analysis of the power consumption of the compressor station(s)
- Recording of the compressed air consumption
- Working out of current energy costs
- Identification of potential savings

Services

- Measurement of compressor operating times as well as load/idling times
- Power consumption measurement
- Flow measurement/consumption measurement
- Pressure measurement (level and tube size)
- Estimation of leakage volume
- Comparison of energy consumption and compressed air volume supplied

General technical conditions

- Simultaneous power consumption measurement on up to 3 compressors
- Simultaneous power consumption measurement on 4 to 11 compressors available on request
- Pressure measurement up to 16 bar
- Volumetric flow rate measurement in main line up to DN 300 (approx. 39,500 Nm³/h)
- Flow sensor can be installed during operation and under pressure
- Measurement duration 1 week (different measurement duration on request)
- Documentation of results as PDF file and printout in colour

The benefits to you

- Information about potential compressed air savings
- Information about current compressed air costs
- Transparent energy consumption of the entire system
- Information about the output reserves of compressed air system
- Fully independent, objective measurement by Festo
- Installation of the measuring devices during operation

Are you interested in this service?

Ask your Festo sales engineer, who will be happy to help.

Or visit your local website at www.festo.com to find out more about our services.

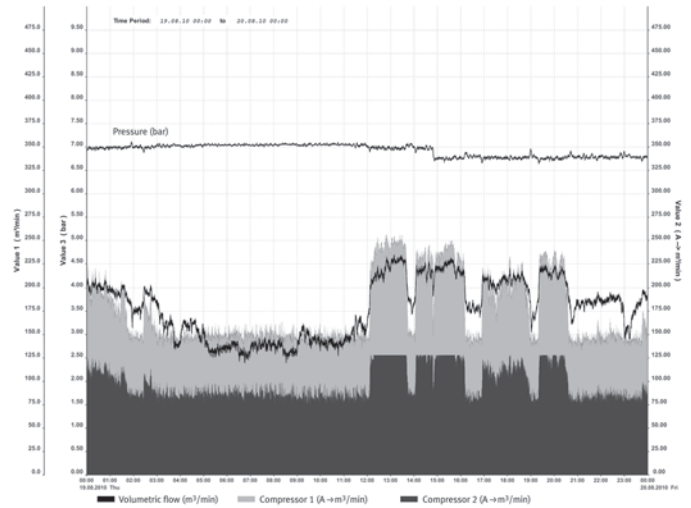

Measurement graph for two compressors: pressure and flow rate over a period of 24 hours



- Determination of exact compressed air consumption
- Optimal configuration of compressed air supply
- No pressure drop due to undersupply
- No unnecessary energy costs due to oversupply

The compressed air consumption of machines and systems is becoming an increasingly important factor. Whether your priority is a reliable compressed air supply or precise cost planning, knowing

the air consumption of your machines and systems in detail is vital for optimum sizing of the compressed air supply. This enables you to avoid unwanted pressure drops, undersupply or unnecessary

energy consumption due to oversupply. The exact efficiency rating of the machine can also be evaluated, which frequently creates new optimisation potential.

Objectives

- Determination and analysis of compressed air consumption and of the leakage of machines and machine lines
- Identification of inappropriate compressed air usage and of improvement potential

Services

- Installation and removal of the measuring equipment with standard components (fittings, tubing, etc.)
- Measurement of flow rate, consumption and pressure with machine running and when idle
- Determination and analysis of different characteristics
 - Consumption per machine cycle
 - Average consumption per minute
 - Average pressure
 - Max./min. pressure
 - Max./min. rate of air flow
- Documentation of measurement results including graphical representation of measurement results, optionally available as PDF file or colour printout
- 3 hours on-site service (additional time on request)

General technical conditions

- Measurement of flow rates from 0.5 l/min ... 5,000 l/min (higher flow rates on request)
- Accuracy of flow rate measurements: +/-4.5%
- Flow measurements in 1" ... 12" lines on request
- Applied measuring principles: usually calorimetric, sometimes differential pressure method
- Pressure range 1 ... 10 bar
- Pressure range up to 50 bar on request
- Sensor installation in supply line or bypass as special solution
- Brief interruption of the compressed air supply line for installation/removal of the measurement technology required
- Compressed air quality min. class 7:4:2 (to ISO 8573-1:2010)
- Provision of measurement results as a CSV file and as a colour printout
- Parallel measurement of multiple flow rates and pressures, including documentation, on request

The benefits to you

- Information about potential compressed air savings
- Use of state-of-the-art, highly accurate pressure and flow measurement technology
- All relevant measuring ranges are covered
- No in-house measurement technology expertise or suitable measurement technology required
- Analysis of measurement results by compressed air specialists
- Documentation of all measurement results

Are you interested in this service?

Ask your Festo sales engineer, who will be happy to help.

Or visit your local website at www.festo.com to find out more about our services.

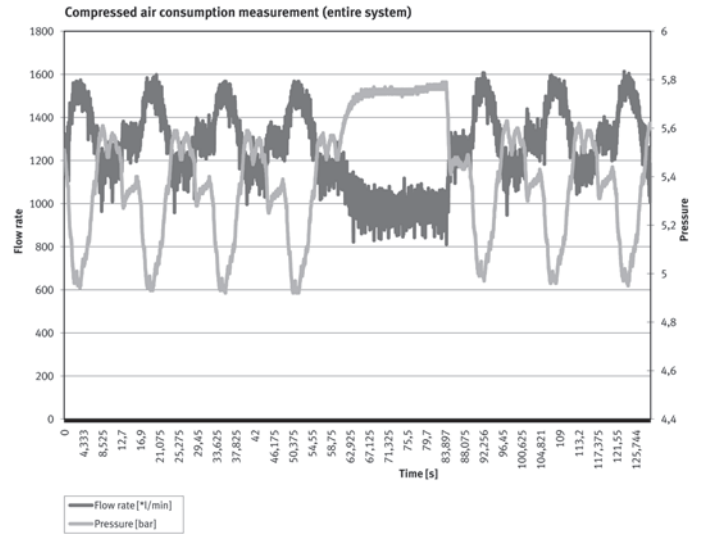

Measurement of compressed air consumption: comparison of pressure and flow rate during operation



- Optimisation of compressed air quality
- Increased service life of components
- Reduction of maintenance costs

Oil, water or particles in compressed air have a negative effect on the service life of pneumatic components. They cause washout of lifetime lubrication and increased wear and damage to seals.

As a result, energy and operating costs rise; in worst-case scenarios, they can lead to unexpected production downtime. Reasons enough to keep an eye on the quality of compressed air.

Objectives

- Optimisation of the current compressed air quality of the compressed air system
- Increase in machine availability and process reliability
- Reduction of maintenance costs

Services

- Inspection of decentralised air preparation at point of usage
- Measurement of residual oil content
- Measurement of pressure dew point
- Analysis of measurement results and recommendation of improvement measures (if applicable)
- Documentation of all measurement results
- 3 hours on-site service (max. 3 measurements; additional time on request)

General technical conditions

- Sampling ideally using standard push-pull fittings or standard O.D. tubing
- Brief interruption of the compressed air supply necessary to install the measurement technology
- Pressure range up to 10 bar
- Measurement of the residual oil content up to class 2 (ISO 8573-1:2010)
- Ester-based oils cannot be verified
- Measurement of the pressure dew point up to class 2 (ISO 8573-1:2010)
- Measurement of pressure dew points lower than -40 °C on request and subject to individual quotation

The benefits to you

- Information about the specific compressed air quality
- Knowledge of required improvement measures
- Use of state-of-the-art measurement technology
- No in-house measurement technology expertise or suitable measurement technology required
- Analysis of measurement results by compressed air specialists
- Documentation of all measurement results

Are you interested in this service?

Ask your Festo sales engineer, who will be happy to help.

Or visit your local website at www.festo.com to find out more about our services.





- Detection and repair of leakages in production plants
- Immediate energy and operating cost savings

Systematically identifying leaks in compressed air systems and professionally eliminating them considerably reduces compressed air costs, because leaky compressed air components are an unnecessary waste of energy and money.

According to a study by the Fraunhofer ISI Institute ("Compressed Air Systems in the European Union", 2000) about 42% of the total potential savings can be achieved in this area alone.

Objectives

- Reduction in pressure drops due to leakages
- Lower compressed air requirements and thus lower operating costs
- Increased process reliability
- Lower CO2 emissions

Services

- Detection of compressed air leakages using highly sensitive ultrasound detectors during operation
- Checking of the complete compressed air system from the compressor to the pneumatic application
- Classification of the leakages according to size and cost
- Documentation of faulty components as well as of the type and cause of the fault
- Leakage report
 - Recommended measures
 - Spare parts required
 - Estimation of repair time
 - Prioritisation of measures
 - Assessment as to whether repair can be carried out while machine is in operation
- Information on optimisation options
- Documentation of measures carried out

General technical conditions

- Contactless ultrasound detection and classification of compressed air leakages (other gases on request)
- Detection while the machines are running, usually no or only short production downtimes required
- Max. detection distance: 20 m
- Documentation of results as Excel file and in some cases as printout in colour

The benefits to you

- Information about potential compressed air savings
- Fast and professional checking of your entire plant for compressed air leakages
- Detection while the machines are running
- Detailed documentation
- Software tools for optimum planning of leakage rectification
- No additional workload for your maintenance personnel
- No investment in measurement technology for leakage detection needed
- Experience from many major projects



Are you interested in this service?

Ask your Festo sales engineer, who will be happy to help.

Or visit your local website at www.festo.com to find out more about our services.

Energy Saving Portal - MyProjects Projects Logoff

Project Administrate

FestID: 10266
Status: Leak Detection

Tags Charts Documents Workflow

Toggle display Export tags Print tags

Values leakages	Total	Open	Done	%share tags	Flow in l/min	%share tot.flow	Costs p./year
Total l/min	3.225,8	1.680,3	1.535,5	Total tags	298	100%	3.225,8
m ³ per year	1.025.814,8	851.925,3	773.889,5	High > 8,7 l/min	74	25%	2.244,4
Costs per year	29.264,67	15.334,66	13.930,01	Medium 2,5 to 8,7 l/min	184	62%	917,5
Cost per m ³	0,018			Low < 2,5 l/min	32	11%	63,9
Co2 per year (kg)	162.243,309723			Optimisation	6	2%	

Total repair time			Repair progress	
Minutes	7715		Open	134
Hours	128,58		Done	162
Days	18,37			

Tag	L.Level	L.Cost	Building	Department	Machine	Manufacturer	Article	Type	Component	Action	Rep	RepProd	Time
1	Med	24,82	RKW	Kesselhaus	RKW	?	L22BA452BQ17G61	Kugelhahn	Fitting	Replace	<input type="checkbox"/>	<input type="checkbox"/>	10
2	Med	23,84	Kesselhaus	Kesselhaus	Rohwasserbehälter B2	Norgren	2636000	Kugelhahn	Valve/valve terminal	Replace	<input checked="" type="checkbox"/>	<input type="checkbox"/>	30
3	Med	22,83	Kesselhaus	Kesselhaus	Rohwasserbehälter B2	Norgren	2636000	Kugelhahn	Fitting	Replace	<input checked="" type="checkbox"/>	<input type="checkbox"/>	10
4	Med	26,32	Kesselhaus	Kesselhaus	BM-5	?	2636000	QSL-1/8-8	Fitting	Replace	<input type="checkbox"/>	<input type="checkbox"/>	30
5	High	78,80	Kesselhaus	Kesselhaus	Straße 1/2 verteiler	?		QSL-1/8-8	Fitting	Replace	<input type="checkbox"/>	<input type="checkbox"/>	30
6	Med	26,80	Kesselhaus	Kesselhaus	K1KLA8, VE-Anlage Straße 1/2	Herion	2638110		Valve/valve terminal	Replace	<input type="checkbox"/>	<input type="checkbox"/>	10

Leakage report with all the necessary information for easy and fast leakage rectification – on the Energy Saving Assessment Portal

What must be taken into account when using Festo products?

The limit values specified in the technical data and any specific safety instructions must be adhered to by the user in order to ensure correct functioning.

When using pneumatic components, ensure that they are operated using correctly prepared compressed air without aggressive media and that they comply with environmental specifications (e.g. climate).

When Festo products are used in safety-oriented applications, all national and international laws and regulations, for example the Machinery Directive, together with the relevant references to standards, trade association rules and the applicable international regulations must be observed and complied with.

Unauthorised conversions or modifications to products and systems from Festo involve a safety risk and are thus not permitted.

Festo does not accept any liability for resulting damages.

You should contact Festo's advisors if one of the following applies to your application:

- The ambient conditions and conditions of use or the operating medium differ from the specified technical data.
- The product is to perform a safety function.
- A risk or safety analysis is required.
- You are unsure about the product's suitability for use in the planned application.
- You are unsure about the product's suitability for use in safety-oriented applications.

All technical data are correct at the time of going to print.

All content, texts, representations, illustrations and drawings included in this catalogue are the intellectual property of Festo AG & Co. KG and are protected by copyright law.

All rights reserved, including translation rights. No part of this publication may be reproduced or transmitted in any form or by any means, electronic, mechanical, photocopying or otherwise, without the prior written permission of Festo AG & Co. KG.

All technical data are subject to change according to technical updates.

Standards in pneumatics

Standards are also of great importance in pneumatics. Standards mean harmonisation. Standardisation is also the basis for the free trade of goods and services between companies nationally as well as internationally.

Standards in industry describe the state-of-the-art technology. They provide a common basis for the evaluation of technical aspects. Standards relevant for pneumatics deal with dimensions, safety

and quality. Festo has for many years been actively working with the relevant national and international standards organisations.

Pneumatic drives

- Standards-based cylinders to ISO 6432
- Standards-based cylinders to ISO 21287

- Standards-based cylinders to ISO 15552 (ISO 6431, DIN ISO 6431, VDMA 24562), NFE 49003.1 and UNI 10290

- Rod clevises to ISO 8140 and DIN 71752

- Rod eyes to ISO 12240-4, dimensional series K

Valves/valve terminals

- Valve terminals for standard valves
- Solenoid and pneumatic valves with port pattern to ISO 15407-1
- Valve sub-bases to ISO 15407-1
- Valve terminals with port pattern to ISO 15407-2

- Solenoid and pneumatic valves with port pattern to ISO 5599-1
- Valve terminals with port pattern to DIN ISO 5599-2

- Valve sub-bases with port pattern to ISO 5599-1 and external dimensions to VDMA 24345

- Solenoid valves with port pattern to VDI/VDE 3845 (NAMUR)

Compressed air preparation

- Compressed air quality to ISO 8573-1:2010
- Bourdon tube pressure gauge to EN 837-1
- Capsule pressure gauge to EN 837-3

- Reservoirs to directive 97/23/EC, 87/404/EEC or EN 286-1

Why compressed air preparation?

Properly prepared compressed air helps to prevent faults in pneumatic components. It increases the service life of the components and reduces machine failures and downtime, thereby increasing process reliability. Compressed air contains contaminants in the form of

- particles,
- water and
- oil.

Particles

Particles in the compressed air usually occur in the form of dust (carbon black, abraded and corrosion particles). Metal chips (e.g. from conversion work) and residues of sealants such as PTFE tape can also occasionally get into the

Water and oil can be in liquid or gaseous form and change from one state to another within the compressed air system. An actual compressed air system will not have any of these contaminants in their pure form; they will occur in a mixture. The composition of this mixture can vary greatly at different times in different places in the system. For example, water can collect in branch lines or particles

compressed air via the compressed air system.

The particles are classified as fine dust: size 0.1 ... 5 µm and coarse dust: size > 5 µm in accordance with ISO 8573-1:2010.

can become deposited in empty spaces over time, and then be propelled along at one stroke by a pressure surge.

Poorly prepared compressed air causes faults such as:

- Accelerated wearing of seals
- Oil-fouled valves in the control section
- Dirty silencers

Possible effects for the user and machine:

- Reduced machine availability
- Higher energy costs due to leakages
- Higher maintenance costs
- Shorter component and system service life

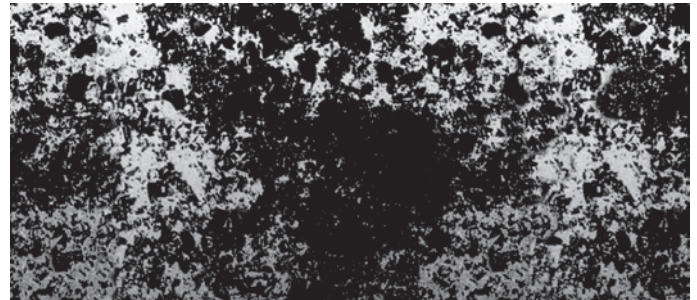

Water content in air

The maximum water content in air (100% relative air humidity) is dependent on temperature. Air can only absorb a certain amount of water (in g) per volumetric unit (in m³), irrespective of pressure. The warmer the air, the more water it can absorb. Excessive humidity manifests itself as condensation. If the air temperature drops, for example from 20 °C to 3 °C,

the maximum water content of compressed air is reduced from 18 g/m³ to 6 g/m³. The compressed air can therefore only absorb approx. 1/3 as much water as before. The rest (12 g/m³) is precipitated as drops (dew) and must be drawn off so that it cannot cause any malfunctions.

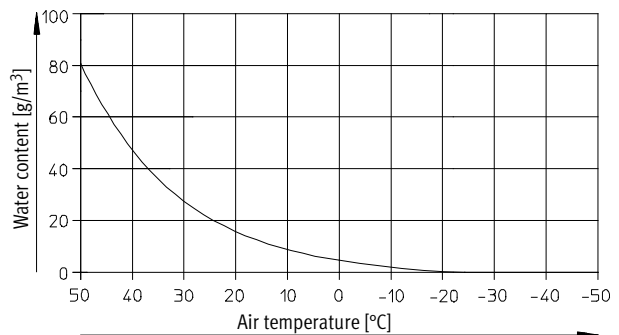

Water condensation

Water is always present in the air in the form of humidity. During the cooling of compressed air, water is released in large quantities. Drying helps to prevent

corrosion damage in compressed air systems and prevents malfunctions in the connected consuming devices.

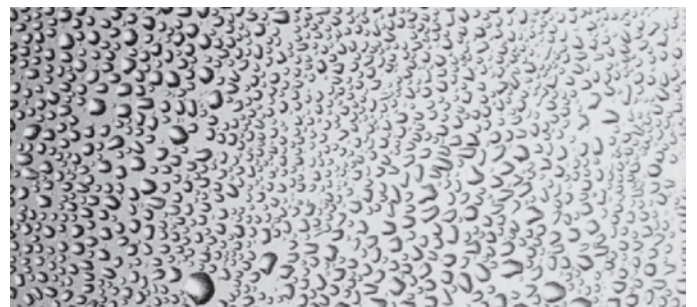

Oil contamination

Similarly, in the case of oil-free operating compressors, oil aerosols present in the drawn-in air also lead to a corresponding residue of oil pollutants. However, this oil

is not suitable for the lubrication of drives and can even lead to the clogging of sensitive parts.

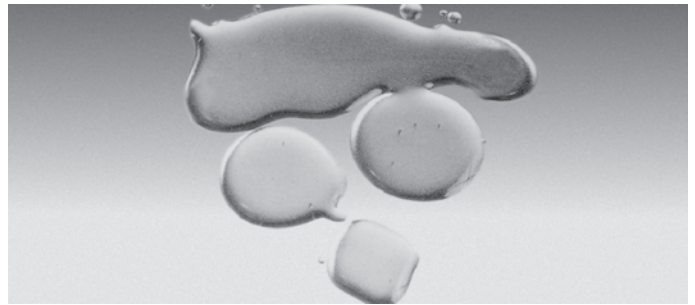

How clean should compressed air be?

The compressed air quality is determined by the requirements

The answer is quite simple: compressed air must be so clean that it cannot cause any malfunctions or damage.

As each filter also creates a flow

resistance, compressed air should be as clean as possible for economic reasons. The wide application range of

compressed air places many different requirements on compressed air quality. If high quality is required, several filtration

stages are necessary → page 1037. If just a single "fine" filter were used, it would quickly become ineffective.

Sizing

Note

Equipment at an air branching/air distribution input should have a high flow rate as it must supply the total air requirement.

More information
→ Chapter 12

The size of the service unit depends on the system's air consumption. Undersizing leads to pressure fluctuations and to reduced filter service life. For cost reasons, high quality

compressed air should only be used where it is absolutely necessary. Branching modules between the individual filter stages enable the user to tap off compressed air of various qualities.

Service unit functions

Compressed air filters remove particles and moisture droplets from the air. Particles > 40 ... 5 µm (depending on the grade of filtration) are retained by a sintered filter. Liquids are separated with the aid of centrifugal force. The condensate which accumulates in the filter bowl must be emptied from time to time, because it would otherwise be drawn in

by the air flow. Various industries often require finely filtered air. Fine and micro filters are used for this. Fine filters are used for pre-filtering down to a particle size of 1 µm.

Micro filters further purify pilot air, removing practically all remaining water and oil droplets and contamination

particles. The degree of compressed air filtration is 99.999% relative to a particle size of 0.01 µm.

The pressure regulator maintains a constant working pressure (secondary side), regardless of the pressure variations in the system (primary side) and the air consumption. Supply pressure must always

be greater than working pressure. The compressed air lubricator provides pneumatic components with adequate lubricant if required. Oil is drawn from a reservoir and atomised when it comes into contact with the air stream. The lubricator is only functional when the air flow is sufficiently strong.

Lubricated compressed air

The following notes must be observed when lubricated compressed air is used:

- Use Festo special oil OFSW-32 or the alternatives listed in the Festo catalogue (as specified in DIN 51524-HLP 32; viscosity 32 cSt at 40 °C).
- If lubricated compressed air is used, additional lubrication must not exceed 25 mg/m³ (ISO 8573-1:2010). The quality of compressed air downstream of the compressor must correspond to that of unlubricated compressed air.
- The lifetime lubrication required for unlubricated operation can be

Oil content

A differentiation must be made between residual oil for operation with unlubricated air and additional oil for operation with lubricated air.

Unlubricated operation:

Examinations involving residual oil content have revealed that the various types of oil have entirely different effects. For this reason, a distinction must be made

Humidity

Max. pressure dew point 3 °C.
Corresponds to ISO 8573-1:2010, at least class 4 → Chapter 12.

"flushed out" when products are operated using lubricated compressed air. This can result in malfunctions if a system is switched back to unlubricated operation after lubricated operation.

- The lubricators should, where possible, always be installed directly upstream of the cylinders used in order to prevent operating the entire system with lubricated air.
- Never over-lubricate the system. To determine the correct lubricator settings, the following "oil form test" can be implemented: hold a piece of white card

between the following oil types when analysing the residual oil content:

- Bio-oils: oils based on synthetic or natural ester (e.g. rapeseed oil methyl ester). In this case, residual oil content must not exceed 0.1 mg/m³. This corresponds to ISO 8573-1:2010 class 2 → Chapter 12. Larger amounts of oil result in damage to O-rings, seals and other equipment parts (e.g. filter

Note

The pressure dew point must be at least 10 K lower than the temperature of the medium, since ice would otherwise form in the expanded compressed air.

approx. 10 cm away from the exhaust port (without silencer) of a working valve of the most distant cylinder. Allow the system to work for some time, the card should only show a pale yellow coloration. If oil droplets appear, this is an indication that too much oil has been used.

- The colour and condition of the exhaust silencer provide further evidence of over-lubrication. Marked yellow coloration and dripping oil indicate that the lubrication setting is too high.
- Dirty or incorrectly lubricated

bowls) in pneumatic systems, and may result in premature product failure.

- Mineral oils (e.g. HLP oils to DIN 51524, part 2) or similar oils based on polyalphaolefin (PAO). In this case, residual oil content must not exceed 5 mg/m³. This corresponds to ISO 8573-1:2010 class 4 → Chapter 12. A higher residual oil content is not permitted, regardless of the

Solids

Permissible particle load max. 10 mg/m³, particle size max. 40 µm.
Corresponds to ISO 8573-1:2010 class 7 → Chapter 12.

Suitable oils

Special oil in 1 litre containers:
Order code OFSW-32

compressed air will reduce the service life of the pneumatic components.

- Service units must be inspected at least twice a week for condensate and correct lubrication settings. These inspections should be included in the machine maintenance plan.
- To protect the environment, as little lubrication as possible should be used. Festo pneumatic valves and cylinders have been designed in such a manner that, under permitted operating conditions, additional lubrication is not required and yet a long service life is guaranteed.

compressor oil, because permanent lubrication would otherwise be flushed out over a period of time. This can lead to malfunctions.

Note

Optimum compressed air preparation means fewer machine failures and greater process reliability. See **Compressed air quality analysis** → 1028

Purity classes for particles to ISO 8573-1:2010

Class	Maximum number of particles per m ³ as a function of particle size d		
	0.1 μm < d ≤ 0.5 μm	0.5 μm < d ≤ 1.0 μm	1.0 μm < d ≤ 5.0 μm
0	As stipulated by the user or supplier of the equipment, stricter requirements than class 1		
1	≤ 20,000	≤ 400	≤ 10
2	≤ 400,000	≤ 6,000	≤ 100
3	Not specified	≤ 90,000	≤ 1,000
4	Not specified	Not specified	≤ 10,000
5	Not specified	Not specified	≤ 100,000

Class	Mass concentration C _p [mg/m ³]
6 ¹⁾	0 < C _p ≤ 5
7 ¹⁾	5 < C _p ≤ 10
X	C _p > 10

- 1) Air cleaned using universal filters designed for particle sizes of 5 μm (class 6) and 40 μm (class 7) is normally used for the compressed air supply to industrial tools and pneumatic machines. These designs have been used for many years, before the latest systems for measuring particle sizes were developed, and have enabled satisfactory operation while minimising pressure (and therefore performance) losses. These filters are not 100% efficient; they offer an efficiency of at least 95% based on the specified particle size, i.e. for class 6, 95% of all particles of size 5 μm are filtered; for class 7, 95% of all particles of size 40 μm are filtered (measured as per ISO 125003).

Purity classes for humidity and liquid water to ISO 8573-1:2010

Class	Pressure dew point [°C]
0	As stipulated by the user or supplier of the equipment, stricter requirements than class 1
1	≤ -70
2	≤ -40
3	≤ -20
4	≤ +3
5	≤ +7
6	≤ +10

Class	Concentration of liquid water C _w [g/m ³]
7	C _w ≤ 0.5
8	0.5 < C _w ≤ 5
9	5 < C _w ≤ 10
X	C _w > 10

Purity classes for total oil content to ISO 8573-1:2010

Class	Total concentration of oil (liquid, aerosol and vapour) [mg/m ³]
0	As stipulated by the user or supplier of the equipment, stricter requirements than class 1
1	≤ 0.01
2	≤ 0.1
3	≤ 1
4	≤ 5
X	> 5

Compressed air quality in use

Designation to ISO 8573-1:2010
[particle:water:oil]

The class that can be achieved with compressed air preparation depends on the quality of the compressed air

downstream of the compressor. The specifications apply to typical

compressed air systems (this list is not exhaustive).

Central air preparation		Air distribution	Decentralised air preparation		Typical applications
Component	Class	Class	Component	Class ³⁾	
Compressor	[-:--]	[-:--]	Water separator	[-:7:4]	All applications where the compressed air must be virtually free from condensate. No defined particle filtering
Compressor + pre-filter + air dryer	[7:4:4] ¹⁾	[-:4:--] ²⁾	Filter 40 µm	[7:4:4]	Operating medium for valves, cylinders, secondary packaging (standard)
			Filter 5 µm	[6:4:4]	Servopneumatic positioning using proportional directional control valves, compressed air tools
			Filter 5 + 1 µm	[5:4:3]	Applications with a residual oil content < 0.5 mg/m ³ , textile industry, pneumatic spinning machines, paper industry
			Filter 5 + 1 + 0.01 µm	[1:4:2]	Applications with a residual oil content < 0.01 mg/m ³ , e.g. air bearings, painting, powder coating
			Filter 5 + 1 + 0.01 µm + activated carbon filter	[1:4:1]	Applications with a residual oil content < 0.003 mg/m ³ , reduction of oil vapours and odours, optical instruments, sealing air for precision glass scales/lasers, primary packaging
			Filter 5 + 1 + 0.01 µm + activated carbon filter + membrane dryer	[1:3:1]	Semiconductor industry, pharmaceutical products
			Filter 5 + 1 µm + adsorption dryer	[2:2:2]	Applications in the low-temperature range, dry process air, powder transportation, food production [1:2:1]

1) Much higher classes are possible with suitable air preparation downstream of the compressor.

2) Pipe systems can increase the particle content of the compressed air (chips, rust, etc.), liquid oil can accumulate in some lines of the compressed air distribution system. Specifications apply at normal room temperature. If parts in the compressed air system are subject to lower temperatures, the humidity class must be chosen so that the pressure dew point is 10 K below the minimum expected temperature.

3) Class according to ISO 8573-1:2010 at room temperature (20 °C).

Definition of the compressed air purity class to ISO 8573-1:2010

The quality of the compressed air is determined by

- solid contaminants (particles),
- humidity and water, and
- oil content.

The air purity class is specified as follows:

- A = Particles
- B = Humidity
- C = Oil content

Example:

ISO 8573-1:2010 [-:7:-]

Particles: Not defined

Humidity: ≤ 0.5 g/m³

Oil content: Not defined

Medium

Under normal operating conditions, pneumatic valves from Festo can be operated with lubricated or unlubricated compressed air.

If any particular product requires a different quality of compressed air, this is indicated in the technical data for the relevant product.

Nominal size

The nominal size provides information about the smallest cross section in the main flow of the valve. It specifies the diameter of the orifice and is expressed

Operation with unlubricated compressed air is made possible by the selection of the material combinations, the shape of the dynamic seals and the basic lubrication applied ex works.

Operation with unlubricated compressed air is not possible under the following operating conditions:

- Once the valves have been operated with lubricated compressed air, it is essential that lubricated compressed air is always used subsequently since the oil in the lubricated air will have flushed away the basic lubrication.

- In all cases, a grade of filtration is required that removes contaminants up to 40 µm (standard filter cartridge version).
Micro compressed air filtration may be required for special applications.

Standard nominal flow rate

Standard nominal flow rate q_{nN} is the flow rate characteristic used by Festo for a device or component expressed in l/min.

The standard nominal flow rate q_{nN} is the flow rate based on standard conditions (to DIN 1343) under the following measurement conditions:

- Test medium air
- Temperature 20 ± 3 °C (temperature of medium)

- Test specimen at ambient temperature
- The pressures to be set are for components with constant cross section (e.g. directional control valves):
Supply pressure $p_1 = 6$ bar
Output pressure $p_2 = 5$ bar

Standard conditions to DIN 1343:

- $t_n = 0$ °C (standard temperature)
- $p_n = 1.013$ bar (standard pressure)

products, the standard nominal flow rate must also be considered.

Exception 1:

Silencer

Supply pressure $p_1 = 6$ bar

Output pressure $p_2 = p_{amb}$

p_{amb} = atmospheric pressure

Exception 2:

Low-pressure components

Supply pressure $p_1 = 0.1$ bar

Output pressure $p_2 = p_{amb}$

Exception 3:

For pressure regulators:

Supply pressure $p_1 = 10$ bar (constant)

and output pressure $p_2 = 6$ bar at

$q = 0$ l/min are set for the test specimen.

Subsequently, the flow rate is slowly and constantly increased using the flow control valve until the output pressure reaches a value of $p_2 = 5$ bar. The resulting flow rate is measured.

Pressure and pressure ranges**Pressure**

Force per area. There is a difference between differential pressure with respect to atmosphere and absolute pressure. Pressure specifications for pneumatic devices must normally be assumed to be the differential pressure with respect to atmosphere, unless expressly indicated otherwise.

Symbol

Differential pressure with respect to atmosphere p

Absolute pressure p_{abs}

Unit: bar, Pa (pascal)

1 bar = 100,000 Pa

Operating pressure

Data quoted as "max." or "max. permissible" values refer to the maximum safe pressure at which a component or system can be operated.

Operating pressure range

The range between the lowest required and highest permissible operating pressure for safe operation of a component or system. This pressure range is also referred to in pneumatics as the working pressure range.

Pilot pressure range

The range between the lowest required and highest permissible pilot pressure for correct operation of a valve or system.

The following pressures, for example, have been standardised to ISO 4399: 2.5, 6.3, 10, 16, 40 and 100 bar.

Drop-off pressure

Pressure which, if no longer maintained, causes a monostable directional control valve to return to the normal position by means of its spring.

Absolute pressure

Zero pressure occurs in a completely air-free space (100% vacuum). Pressure that is calculated from this theoretical zero point is absolute pressure.

Response pressure

Pressure at which a directional control valve is actuated. Catalogue specifications for response pressure signify that the indicated minimum pressure must be present at the signal input to safely switch the valve.

Port designations of pneumatic components to ISO 5599

FESTO

Port designations	Using ISO 5599 numbers (5/2-way and 5/3-way valves)	Using letters ¹⁾
	Supply port	1
Working ports	2	B
	4	A
		C
Exhaust ports	3	S
	5	R
		T
Pilot ports (signal)	10 ²⁾	Z ²⁾
	12	Y
	14	Z
Pilot air ports (power supply)	81 (12)	
	81 (14)	
Pilot exhaust ports	83 (82)	
	83 (84)	
Leakage lines		L

1) Still frequently used

2) Clears the output signal

Medium

Under normal operating conditions, pneumatic drives from Festo can be operated with lubricated or unlubricated dried compressed air. If any particular product requires a different quality of compressed air, this is indicated in the

technical data for the relevant product. Operation with unlubricated compressed air is made possible by the choice of materials used, the material combinations, the shape of the dynamic seals and the basic lubrication applied ex works.

Operation with unlubricated compressed air is not possible under the following operating conditions:

- Once the drives have been operated with lubricated compressed air, it is essential that lubricated compressed air is always used subsequently since the oil in the lubricated air will have flushed away the basic lubrication.

Recommended operating conditions

Pneumatic drives are intended to convert pressure energy into motion energy; this process involves the transmission and dissipation of forces. "Recommended

operating conditions" do not include use as a spring or cushioning device, since this would involve additional loads.

Frequency

If pneumatic drives are operated at maximum possible speed, a pause time must be taken into account between the stroke movements. For operation with

unlubricated compressed air, the maximum frequency should be based on an average speed of 1 m/s.

Assembly position

In general, drives from Festo can be installed in any desired position. If any limitations or special measures apply, these are indicated in the technical data for the relevant product.

Operating pressure

Data quoted as "max." or "max. permissible" values refer to the maximum safe pressure at which a drive or system can be operated.

Operating pressure range

The range between the lowest required and highest permissible operating pressure for safe operation of a component or

system. This pressure range is also referred to in pneumatics as the working pressure range.

Effective force with single-acting cylinders

Permissible deviation of spring forces in accordance with DIN 2095, quality class 2, must be taken into consideration for the cylinders' effective force. The effective

force must also be reduced by the value of prevailing frictional forces.

The degree of friction depends upon the assembly position and the type of load involved. Lateral forces increase friction. Frictional force must be lower than spring

return force. In as far as this is possible, single-acting cylinders should be operated without lateral forces.

Permissible stroke deviations for standard cylinders

ISO 15552 (corresponds to the withdrawn standards ISO 6431, DIN ISO 6431, VDMA 24562, NFE 49003.1, UNI 10290), ISO 6432

and ISO 21287 permit a certain amount of stroke length deviation from the nominal value due to manufacturing tolerances. These tolerances are always

positive. Refer to the table for details regarding precise permissible deviations.

Standard	Piston \varnothing [mm]	Stroke length [mm]	Permissible stroke deviation [mm]
ISO 6432	8, 10, 12, 16, 20, 25	0 ... 500	+1.5
ISO 15552	32	0 ... 500	+2
	40, 50	500 ... 12,500	+3.2
	63	0 ... 500	+2
	80, 100	500 ... 12,500	+4
	125, 160	0 ... 500	+4
	200, 250, 320	500 ... 2,000	+5
ISO 21287	20, 25	0 ... 500	+1.5
	32, 40, 50	0 ... 500	+2
	63, 80, 100	0 ... 500	+2.5

Note
In the case of stroke lengths larger than those shown in the table, the tolerances must be agreed upon between the manufacturer and the user.

Contactless position sensing

Pneumatic drives from Festo with contactless position sensing are fitted with a permanent magnet on the cylinder piston, the magnetic field of which is used to actuate proximity sensors. Proximity

sensors can be used to detect end or intermediate positions of cylinders. One or more proximity sensors can be clamped to a cylinder, either directly or using mounting kits.



Piston diameter



This pictogram is used to indicate piston diameter. This is represented by \varnothing only in the dimensions table.

Piston force [N] ∅	Operating pressure [bar]							
	1	2	3	4	5	6	7	8
2.5	0.4	0.9	1.3	1.8	2.2	2.7	3.1	3.5
3.5	0.9	1.7	3.8	3.5	4.3	5.2	6.1	6.9
5.35	2	4	6.1	8.1	10.1	12.1	14.2	16.2
6	2.5	5.1	7.6	10.2	12.7	15.3	17.8	20.4
8	4.5	9	13.6	18.1	22.6	27.1	31.7	36.2
10	7.1	14.1	21.2	28.3	35.3	42.4	49.5	56.5
12	10.2	20.4	30.5	40.7	50.9	61.0	71.3	81.4
16	18.1	36.5	54.3	72.4	90.5	109	127	145
20	28.3	56.5	84.8	113	141	170	198	226
25	44.2	88.4	133	177	221	265	309	353
32	72.4	145	217	290	362	434	507	579
40	113	226	339	452	565	679	792	905
50	177	353	530	707	884	1,060	1,240	1,410
63	281	561	842	1,120	1,400	1,680	1,960	2,240
80	452	905	1,360	1,810	2,260	2,710	3,170	3,620
100	707	1,410	2,120	2,830	3,530	4,240	4,950	5,650
125	1,100	2,210	3,310	4,420	5,520	6,630	7,730	8,840
160	1,810	3,620	5,430	7,240	9,050	10,900	12,700	14,500
200	2,830	5,650	8,480	11,300	14,100	17,000	19,800	22,600
250	4,420	8,840	13,300	17,700	22,100	26,500	30,900	35,300
320	7,240	14,500	21,700	29,000	36,200	43,400	50,700	57,900

Piston force [N] ∅	Operating pressure [bar]						
	9	10	11	12	13	14	15
2.5	4	4.4	4.9	5.3	5.7	6.2	6.6
3.5	7.8	8.7	9.5	10.4	11.3	12.1	13
5.35	18.2	20.2	22.2	24.3	26.3	28.3	30.3
6	22.9	25.4	28	30.5	33.1	35.6	38.2
8	40.7	45.2	49.8	54.3	58.8	63.3	67.9
10	63.6	70.7	77.8	84.8	91.9	99	106
12	91.6	101	112	122	132	143	153
16	163	181	199	217	235	253	271
20	254	283	311	339	368	396	424
25	398	442	486	530	574	619	663
32	651	724	796	869	941	1,010	1,090
40	1,020	1,130	1,240	1,360	1,470	1,580	1,700
50	1,590	1,770	1,940	2,120	2,300	2,470	2,650
63	2,520	2,810	3,090	3,370	3,650	3,930	4,210
80	4,070	4,520	4,980	5,430	5,880	6,330	6,790
100	6,360	7,070	7,780	8,480	9,190	9,900	10,600
125	9,940	11,000	12,100	13,300	14,400	15,500	16,600
160	16,300	18,100	19,900	21,700	23,500	25,300	27,100
200	25,400	28,300	31,100	33,900	36,800	39,600	42,400
250	39,800	44,200	48,600	53,000	57,400	61,900	66,300
320	65,100	72,400	79,600	86,900	94,100	101,000	109,000

The piston force F can be calculated from the piston area A, the operating pressure p and the friction R using the following formulae:

Piston force (final pressure)

$$F = p \cdot A - R$$

$$F = p \cdot 10 \cdot \frac{d^2 \cdot \pi}{4} - R$$

p = Operating pressure [bar]

d = Piston diameter [cm]

R = Friction ~10% [N]

A = Piston area [cm²]

F = Effective piston force [N]

ProPneu software tool for sizing can be found on the DVD and at www.festo.com

Pressure/force graph

Operating pressure p as a function of piston diameter and force F

An allowance of 10% has been included for frictional force

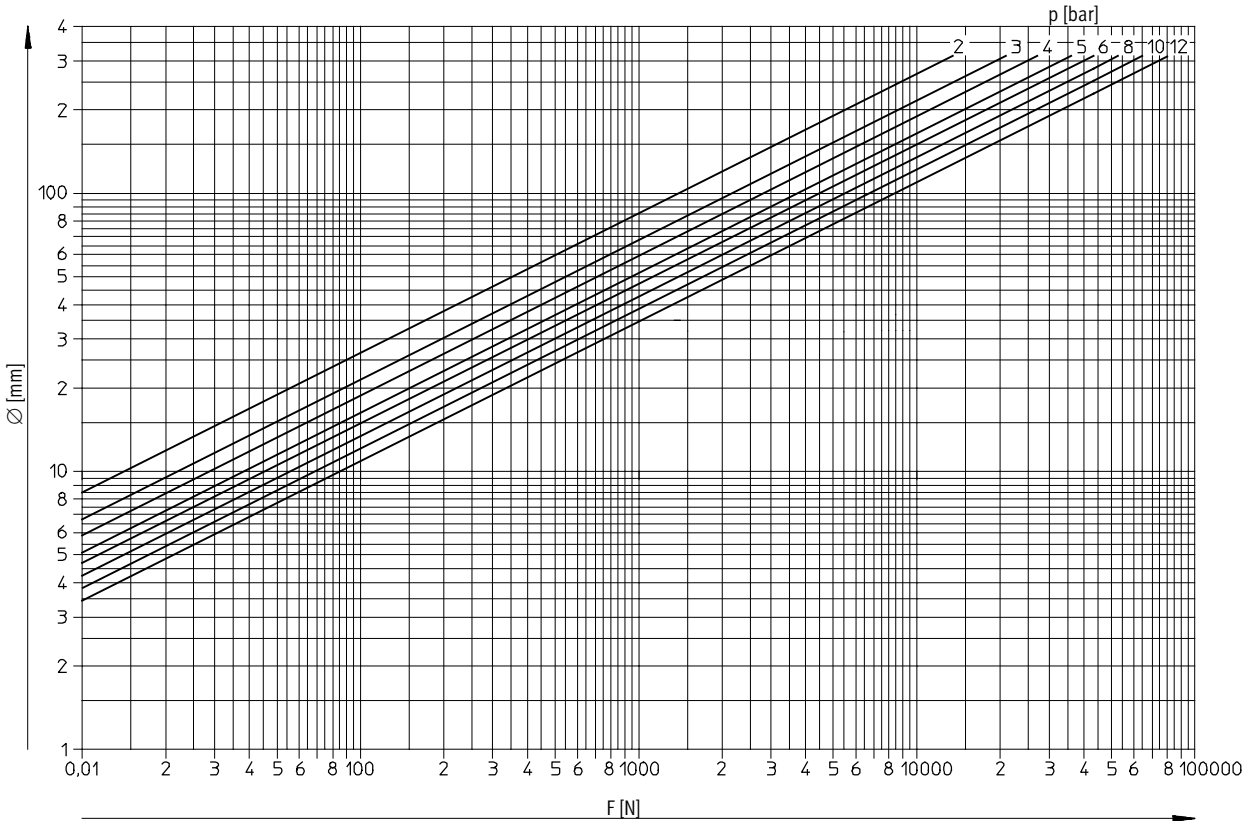

Given:
 Load 800 N
 Available system pressure 6 bar

To be found:
 Required piston diameter
 Operating pressure to be set

Procedure:
 From $F = 800$ N go vertically upwards to the point of intersection with the 6 bar line. The next largest piston diameter, 50 mm, lies between the lines for 4 and 5 bar, which means that the operating pressure should be set to approx. 4.5 bar.

The selection of pneumatic drives is governed primarily by the forces to be overcome and the distances to be travelled. A small percentage of the piston force is used to overcome friction, the remainder is used to drive the load. Only approximate values can be given, since frictional force depends on

numerous factors (lubrication, operating pressure, back pressure, seal design, etc.). Back pressure generates a force which acts in the opposite direction and partially cancels out the effective force. Back pressure occurs in particular when exhaust air flow controls are used or the exhaust port is constricted.

Piston rod diameter as a function of stroke length l and force F

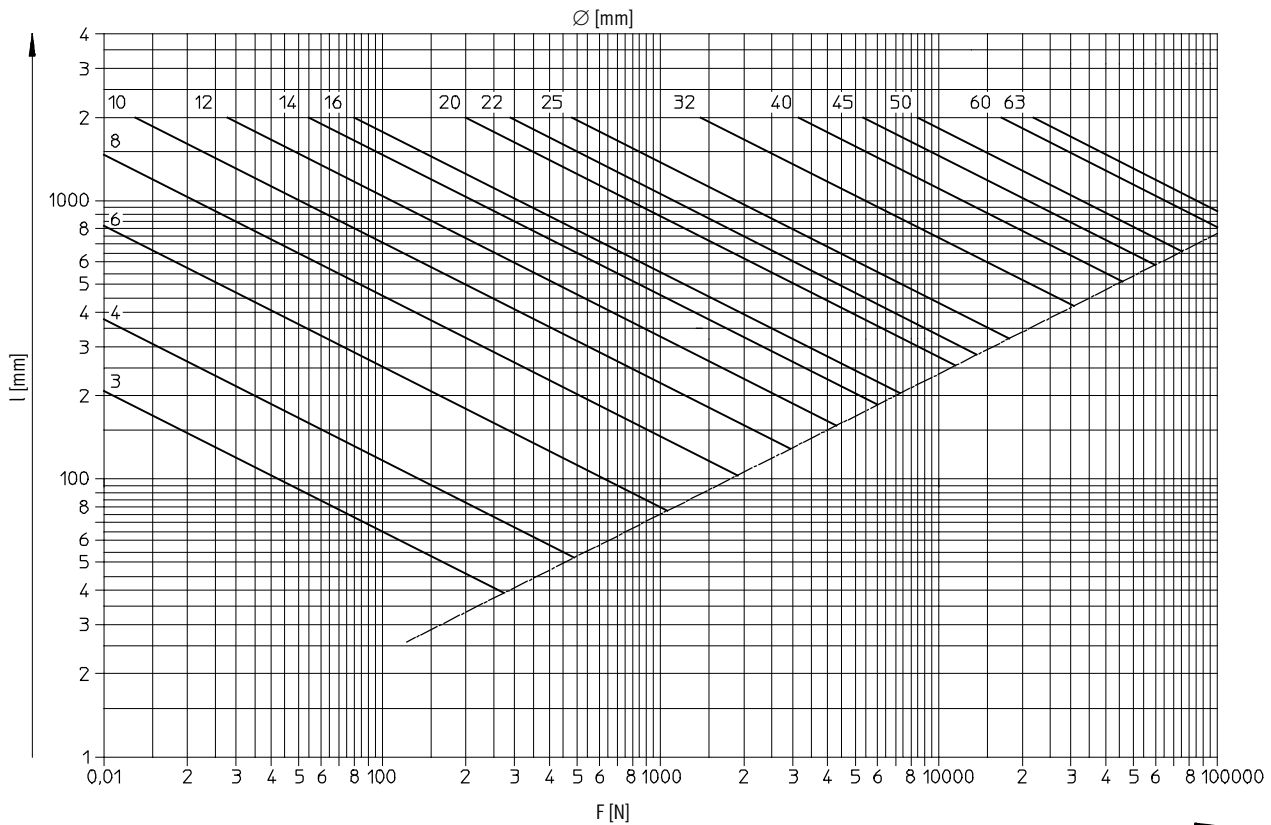

Given:

Load 800 N

Stroke length 500 mm

Piston diameter 50 mm

To be found:

Piston rod diameter

Cylinder type: Standard cylinder

Procedure:

From $F = 800$ N go vertically upwards to the point of intersection with the horizontal line through $l = 500$ mm. The next largest piston rod diameter in the graph is 16 mm. The standard cylinder DNC-50-500 with a piston rod diameter of 20 mm is suitable for this stroke length.

Due to buckling stress, the maximum permissible load for a piston rod with a long stroke length is lower than the value suggested by the maximum permissible operating pressure and piston area. This load must not exceed certain maximum values. These depend upon stroke length and piston rod diameter.

The graph shows this relationship based on the following formula:

$$F_K = \frac{\pi^2 \cdot E \cdot J}{l^2 \cdot S}$$

F_K = Permissible buckling force [N]

E = Modulus of elasticity [N/mm²]

J = Moment of inertia [cm⁴]

l = Buckling length

= 2x stroke length [cm]

S = Safety factor (selected value: 5)

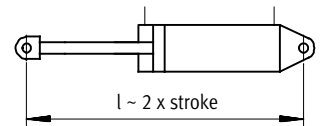

Note

The least satisfactory type of mounting for this kind of stress is a swivel mounting. The permissible load is higher for other types of mounting.

Air Consumption sizing software

The "Air Consumption" sizing software determines the air consumption of a cylinder (approximate value), taking into consideration the following parameters:

- Mode of operation of the cylinder
- Piston diameter
- Number of cycles
- Stroke length
- Operating pressure

This tool can be found online under Support in the Engineering software area.

Calculating air consumption using the sizing software

Given:

- Cylinder: DNC-32-500
- Piston diameter: 32 mm
- Piston rod diameter: 12 mm
- Stroke length: 500 mm
- Operating pressure: 6 bar
- Number of cycles per minute: 60 1/min

To be found:

Air consumption

Result:

- Once the parameters have been entered, the following values are returned for the air consumption:
- Per cycle: 5.23 l
- Per minute: 314.03 l

Cylinder Air Consumption

Calculating air consumption using the formula

$$Q = \frac{\pi}{4} \cdot (d_1^2 - d_2^2) \cdot h \cdot (p + 1) \cdot 10^{-6}$$

- Q = Air consumption per cm stroke [l]
- d1 = Piston diameter [mm]
- d2 = Piston rod diameter [mm]
- h = Stroke [mm]
- p = Operating pressure, relative [bar]

Forward stroke:

$$Q = \frac{\pi}{4} \cdot (32\text{mm})^2 \cdot 500\text{mm} \cdot (6\text{bar} + 1\text{bar}) \cdot 10^{-6}$$

$$Q = 2.815\text{l}$$

Return stroke:

$$Q = \frac{\pi}{4} \cdot ((32\text{mm})^2 - (12\text{mm})^2) \cdot 500\text{mm} \cdot (6\text{bar} + 1\text{bar}) \cdot 10^{-6}$$

$$Q = 2.419\text{l}$$

Air consumption per cycle:

$$Q = 2.815\text{l} + 2.419\text{l} = 5.234\text{l}$$

Pneumatics and explosion protection – Directive 94/9/EC (ATEX)



What does ATEX mean?

Explosive atmospheres are a constant hazard in the chemical and petrochemical industries because of the processing techniques used. These explosive atmospheres are caused by escaping gas,

vapours and mist, for example. Explosive atmospheres can also be expected in mills, silos and sugar and feed processing plants because of the dust/

oxygen mixtures that occur there. For this reason, electrical equipment in potentially explosive areas is subject to a special directive, 94/9/EC. This directive

was also extended to non-electrical equipment on 01.07.2003.



ATEX - Directive 94/9/EC

ATEX is an acronym of the French expression "Atmosphère explosible".

- **Directive 94/9/EC** stipulates the minimum safety requirements for equipment and protective systems that are to be operated in explosive atmospheres and that have their own ignition sources.
- It applies to the sale of equipment and protective systems in/within the European Economic Area.
- It relates to both electrical and non-electrical equipment, if they have their own potential ignition source.

Dual responsibility

When equipment for explosion protection areas is being produced, system manufacturers and component suppliers must work closely together to ensure that the correct category and explosion protection zone are chosen.

Explosion protection documentation from system manufacturer	Festo/equipment supplier
System rating Directive 99/92/EC 	Equipment rating Directive 94/9/EC 
Result: • Zone classification • Temperature classes • Explosion groups • Ambient temperature	Result: • Equipment categories • Temperature classes • Explosion groups • Ambient temperature
Zone	Category

Explosion protection classes					
Gas zone	Dust zone	Frequency	Equipment group	Equipment category	Area of application
–	–	–	I	M	Mining
				M1	
M2					
0	–	Constant, frequent, long-term	II	–	All non-mining areas of application
				1G	Gas, mist, vapour
–	20		II	1D	Dust
1	–	Occasional	II	2G	Gas, mist, vapour
				2D	Dust
2	–	Seldom, short-term in the event of a fault	II	3G	Gas, mist, vapour
				3D	Dust
–	22		II		

EC directives (CE marking)



Festo AG & Co. KG adheres in principle to the applicable regulations. All information is based on the state of knowledge today and is subject to change. We carefully follow any amendments/additions to these regulations and will produce our products accordingly. This guarantees that products from Festo AG & Co. KG always comply with the currently valid requirements.

Most pneumatic products are not subject to any EC directive and consequently must not be labelled with the CE marking. Currently, products from the sales range of Festo AG & Co. KG that are labelled with the CE marking are subject to one or more of the following six EC directives in Europe.

1. EC Machinery Directive 2006/42/EC
Pneumatic products from Festo AG & Co. KG are designed in compliance with the standards for pneumatic systems to ISO 4414 as well as EN 983 "Safety requirements for fluid systems and their pneumatic components". Our pneumatic products do not fall within the scope of application specified in the EC Machinery Directive.

They must therefore not be labelled with the CE marking in accordance with the Machinery Directive. Exceptions to this are safety components. As of 29.12.2009, incomplete machines also fall under the scope of application of the Machinery Directive. These include handling systems intended for installation in machines, for example. Incomplete machines are not labelled with the CE marking. A declaration of incorporation is enclosed with the machines instead of a declaration of conformity.

2. EC Directive on Electromagnetic Compatibility (2004/108/EC), including amendments.

The directive must be applied to our electronic and electronic/pneumatic products. This means that corresponding products have had the CE marking since 01.01.1996 and the corresponding declaration of conformity is available. For you, this means a guarantee that this equipment complies with the fundamental requirements in industrial areas. The use of this equipment in residential areas is restricted if no additional measures are taken to guarantee compliance with the fundamental requirements of the directive for residential areas. Solenoid coils are not affected by the EMC Directive.

3. EC Low Voltage Directive (2006/95/EC), including amendments.

Since 01.01.1997, electrical and electronic products from Festo designated for use within specific voltage limits (50 ... 1,000 V AC and 75 ... 1,500 V DC) must be labelled with the CE marking. The corresponding declarations of conformity are available.

These products are labelled with the CE marking. The declaration of conformity is available.

4. EC Directive on Simple Pressure Vessels (2009/105/EC), including amendments.

In force since 30.06.1991. The simple pressure vessels made from non-alloyed steel offered by Festo AG & Co. KG comply with the requirements of this directive. These air reservoirs require CE marking above a certain volume.

5. EC Directive on Pressure Equipment (97/23/EC), including amendments.

In force since 29.05.2002. The pressure vessels offered by Festo AG & Co. KG comply with the requirements of this directive. These pressure vessels require CE marking above a certain pressure/volume product or pressure/diameter product.

These products are labelled with the CE marking. The declaration of conformity is available.

Reservoirs made from stainless steel are subject to the Directive on Pressure Equipment rather than the Directive on Simple Pressure Vessels.

6. EC Directive on Equipment and Protective Systems intended for use in Potentially Explosive Atmospheres - ATEX (94/9/EC).

In force since 01.07.2003. The products offered by Festo AG & Co. KG which are intended for use in potentially explosive atmospheres and which have their own potential ignition risk comply with the requirements of this directive. Products that are subject to this directive are correspondingly labelled with the CE marking and identified in compliance with the directive. The corresponding declaration of conformity and the operating instructions are available.

Product markings	
	See above
	In accordance with EU directive 94/9/EC (ATEX) Additional marking for equipment and protective systems for use in accordance with regulations in a potentially explosive atmosphere.
	UL certification for use in Canada and the USA. Recognized Product intended for installation, for example MPA-S valve terminal.
	UL certification for use in Canada and the USA. Listed Product, a ready-to-use device, for example limit switch with cable and plug.
	CSA certification for Canada and the USA.

Food compatibility to HACCP

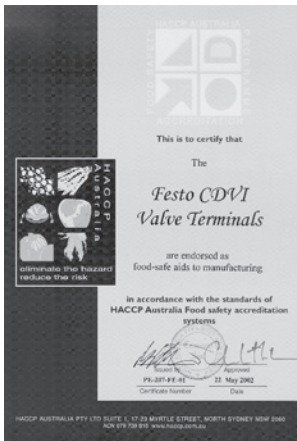

The HACCP standard (HACCP = Hazard Analysis Critical Control Points) describes a procedure for the identification, assessment and prevention of risks and hazards. The main focus is on biological, chemical and physical risks in the production process. The HACCP standard is also part of the EC Directive on Food Hygiene (93/43/EEC).

Clean room suitability



Qualifizierungsbescheinigung
Certificate of qualification

Cost-effective series for clean room class 7

At Festo, cost-effective standard pneumatic components take the place of complex special designs. This is possible because the quality concept is compatible with almost all standard production products. These standard pneumatic components are suitable for use in a class 7 clean room according to ISO 14644-1.

Close-to-standard products for clean rooms to class 4

Stringent requirements but still an optimum cost/benefit ratio. At Festo, class 4 also means standard products – with just one restriction: they are not available ex-stock. Nonetheless, they can be delivered to you within the shortest possible time.



IPA-Qualifizierungskunde

Kunde wird bescheinigt, daß für unversehrte Produkte der Hersteller:
Festo KG
Bestraße 12
40784 Solingen
die IPA-Qualifizierung mit der Bericht Nummer FE 9805-153 erlangt wurde.
Die Bescheinigung (FestO) mit Bandabdeckung und Unterdruckabzuegung ist für die Anwendung in Reinräumen (ISO 14644-1) Klasse 4 bis Klasse 7 geeignet.
Die Bescheinigung ist für die Anwendung in Reinräumen (ISO 14644-1) Klasse 4 bis Klasse 7 geeignet.
Die Bescheinigung ist für die Anwendung in Reinräumen (ISO 14644-1) Klasse 4 bis Klasse 7 geeignet.
Hofheim, den 11. Mai 1998

J. A. Beck

Fraunhofer IPA
Produktionsfähigkeit und
Automatisierung

Design awards



product design award



reddot

Festo products appear regularly on the winners' rostrum in major design competitions. There is much more to good design than being "pleasing to the eye". The design emphasises and symbolises the cutting-edge technology and long-standing value of Festo products.

→ www.festo.com/en/clean room

The reliability to meet the highest requirements

Festo works with the Fraunhofer Institute for Production Technology and Automation (IPA) and the renowned Nanyang Technological University in Singapore to ensure that its products meet the high requirements for use in clean rooms. A dedicated Competence Centre for Cleanroom Technology at Festo Singapore offers the necessary infrastructure for the production of pneumatic clean room products.

PWIS-free products

	PW	I	S
Paint-wetting			
impairment			
substances			

PWIS are substances that cause small concave indentations at various points in the paint layer when surfaces are painted.

Silicone, fluoric materials, certain oils and greases may contain substances of this kind.

The following are PWIS-free

- Individual parts and modules that are manufactured without using materials, consumables or sundries containing paint-wetting impairment substances. Tests carried out during the sampling

Components used in the automotive industry, and especially in painting equipment, must be free of paint-wetting impairment substances.

Because it is impossible to determine the level of paint-wetting impairment substances contained in substances and

procedure as well as random sample testing of incoming goods by means of extraction must not cause any paint-wetting impairment effects.

components with the naked eye, Volkswagen developed the testing standard PV 3.10.7.

All products from Festo and the lubricants used in them undergo this test. Products from Festo are free of

- Liquid or paste-like sundry materials (e.g. lubricating greases) that do not cause any paint-wetting impairment effects through application as a result of the test.

paint-wetting impairment substances as standard.

However, it is necessary to use grease containing paint-wetting impairment substances for some products for functional and other reasons.

- Products that consist of PWIS-free parts and contain PWIS-free lubricants.

Media resistance database

It is well known that the resistance of materials depends on many parameters such as concentration of contact medium, temperature, pressure, length of contact, stroke speed and switching frequency, surface finish in the case of mating frictional parts, current speed and stress as well as ageing.

This applies in particular to the compatibility of elastomers with special chemical compounds.

The Festo resistance database shows you the suitable material and its resistance to chemical substances.

The information contained in this database is based on lab tests from raw material manufacturers, material tables

from semi-finished product and seal suppliers and practical experience.

The information is evaluated and the tables are created based on the knowledge available. Although every effort has been made to ensure the accuracy of this database, its contents should only be used for reference purposes.

Please note that the recommendations in this resistance database can neither be guaranteed nor serve as the basis for a warranty claim.

Wherever possible and especially in cases of doubt, it is advisable to perform a practical test with the desired product under actual operating conditions.

www.festo.com/media-resistance

The screenshot shows the Festo website's media resistance database. It features a search bar, navigation tabs for 'Tubings', 'Elastomers', 'Metals', and 'Plastics', and a search result table. The table lists various Festo materials (PUN-H, PUR, PLN, PAN, PAN-PEN, PFAN, PAN-R, PUN-V0-B) and their resistance to acetic acid at different concentrations and temperatures. A key explains the symbols: '-' for resistant, 'o' for conditionally resistant, and blank for no specification.

Acetic acid(CH ₃ COOH) Concentration 10%, Temperature 20°C	PUN-H	PUR	PLN	PAN	PAN-PEN	PFAN	PAN-R	PUN-V0-B
	-	-	-	-	-	-	-	-
Acetic acid(CH ₃ COOH) Concentration 85%, Temperature 40°C	PUN-H	PUR	PLN	PAN	PAN-PEN	PFAN	PAN-R	PUN-V0-B
	-	-	-	-	-	-	-	-
Acetic acid(CH ₃ COOH) Concentration 25%, Temperature 40°C	PUN-H	PUR	PLN	PAN	PAN-PEN	PFAN	PAN-R	PUN-V0-B
	-	-	-	-	-	-	-	-
Acetic acid(CH ₃ COOH) Concentration 100%, Temperature 20°C	PUN-H	PUR	PLN	PAN	PAN-PEN	PFAN	PAN-R	PUN-V0-B
	-	-	-	-	-	-	-	-
Acetic acid (glacial)(CH ₃ COOH) Concentration 100%, Temperature 20°C	PUN-H	PUR	PLN	PAN	PAN-PEN	PFAN	PAN-R	PUN-V0-B
	-	-	-	-	-	-	-	-

Protection of electrical equipment

The terminology for "IP" (International Protection) is defined by IEC/EN 60529 "Degree of Protection Provided by Enclosures (IP Code)" and DIN 40050 "IP Protection Classes" (standard for electrical equipment in road vehicles). These standards describe the classification of the degrees of protection provided by enclosures for electrical equipment with rated voltages of up to and including 72.5 kV. They set forth requirements for the following:

- Protection of individuals against contact with live or moving components within enclosures (protection against accidental contact).
- Protection of equipment inside the housing against ingress of solid foreign matter, including dust (protection against foreign matter).
- Protection of electrical equipment against damage that would result if water were to enter the enclosure (protection against water).

The IP code to IEC/EN 60529

The protection class provided by an enclosure is established using standardised testing methods. The IP code is used for classifying this protection class.

The IP code is made up of the letters IP and a two-digit code number. The definition of both digits is explained in the table on the next page → 1051.

Meaning of digit 1:

Digit 1 denotes firstly the protection of individuals. It specifies the extent to which the enclosure prevents individuals from coming into contact with dangerous parts. The enclosure prevents or restricts the entry of body parts or of objects held by an individual. Secondly, digit 1 specifies the extent to which the equipment is protected against the ingress of solid foreign objects.

Meaning of digit 2:

Digit 2 refers to the protection of equipment. It rates the protection class of the enclosure with respect to the harmful effects on the equipment due to water entering the enclosure.

Note

The food industry generally uses components with IP protection class 65 (dustproof and hose-water proof) or IP67 (dustproof and capable of brief submersion). The use of IP65 or IP67 depends on the specific application, as each is governed by completely different test criteria. IP67 is not necessarily better than IP65. A component that fulfils the IP67 criteria does therefore not automatically meet the criteria for IP65.

IP codes

IP 6 5

Code letters	
IP	International Protection

Digit 1	Brief description	Definition
0	Not protected	–
1	Protected against solid foreign objects, 50 mm and larger	A probing object, a ball of 50 mm in diameter, must not enter or penetrate the enclosure.
2	Protected against solid foreign objects, 12.5 mm and larger	A probing object, a ball of 12.5 mm in diameter, must not enter or penetrate the enclosure.
3	Protected against solid foreign objects, 2.5 mm and larger	A probing object, a ball of 2.5 mm in diameter, must not penetrate at all.
4	Protected against solid foreign objects, 1.0 mm and larger	A probing object, a ball of 1 mm in diameter, must not penetrate at all.
5	Protected against dust	The ingress of dust is not completely prevented. The amount of dust that enters must not impair the safety or satisfactory operation of the equipment.
6	Dustproof	No ingress of dust.

Digit 2	Brief description	Definition
0	Not protected	–
1	Protected against water droplets	Vertically falling droplets may not have any harmful effect.
2	Protected against water droplets	Vertically falling droplets must not have any harmful effect when the enclosure is at an angle of 15° either side of the vertical.
3	Protected against spray water	Water sprayed at any angle of up to 60° either side of the vertical must not have any harmful effect.
4	Protected against water splashes	Water splashing against the enclosure from any angle must not have any harmful effect.
5	Protected against water jets	Water jets directed at the enclosure from any angle must not have any harmful effect.
6	Protected against powerful water jets	Powerful water jets directed against the enclosure from any angle must not have any harmful effect.
7	Protected against the effect of brief submersion in water	Water must not enter the equipment in amounts that can have a harmful effect if the enclosure is briefly submerged in water under standardised pressure and time conditions.
8	Protected against the effect of continuous submersion in water	Water must not enter the equipment in amounts that can have a harmful effect if the enclosure is continuously submerged in water. The conditions must be agreed between the manufacturer and the user. The conditions must, however, be more severe than code 7.
9K	Protected against water from high-pressure and steam jet cleaning	Water directed at the enclosure from any angle under high pressure must not have any harmful effect.

Concepts for ensuring protection against electric shock to IEC 60364-4-41/VDE 0100 Part 410

Definitions

Protection against electric shock means protection against indirect and direct contact.

Protection against direct contact implies that under normal operating conditions, live parts which are not insulated are protected against accidental contact.

Protection against indirect contact implies that in the event of an insulation fault between live parts and bodies or enclosures, contact voltages outside of the permissible range cannot occur or are disconnected promptly.

The three best-known and most widely used concepts for ensuring protection against electric shock are also referred to as protection class I to III in specialist literature and standardisation documentation.

Protection class I – Protective earth conductor

In the case of electrical equipment in protection class I, protection against direct contact is ensured by means of basic insulation.

Protection against indirect contact is provided by means of prompt

disconnection of the fault voltage. This disconnection is ensured by the contacting of the protective earth conductor on the equipment enclosure via protective earth.

If an insulation fault occurs in the

equipment, the fault current flows via the protective circuit against the earth potential, thereby triggering the upstream fuse element (e.g. residual current device protection or circuit-breaker).

Equipment in protection class I includes lights, white goods (washing machines, dryers, etc.) and industrial machinery. Symbol:



Protective class II – Protective insulation

In the case of equipment in protection class II, the protection refers to direct and indirect contact with the improved enclosure insulation. The enclosure insulation is reinforced or doubled so that it

is not possible to come into contact with contact voltages outside of the permissible range either in the event of a fault or during operation.

Equipment in protection class II must not be connected to the protective circuit. Therefore the equipment does not have a protective contact on the plug.

Equipment in protection class II includes hi-fi components, electric power tools and household appliances and is identified with the following symbol:



Protective class III – Protective extra-low voltage

In the case of equipment in protection class III, protection against direct and indirect contact is ensured both by means of a sufficiently high IP protection

class (protection against direct contact with live parts) and electrical supply of the component with PELV (protective ex-

tra-low voltage) or SELV (safety extra-low voltage) (protection against indirect contact in the event of a fault).

Equipment in protection class III is frequently identified (no mandatory identification) with the following symbol:

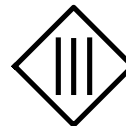

Special protection class for components from Festo**Protection class III**

On the basis of the information currently available, all 24 V DC valve terminals (e.g. CPV, MPA), position controllers (e.g. PLCs), sensors (proximity sensors, pressure switches, pressure sensors) and proportional valves from Festo belong to protection class III.

This means that, in the case of the 24 V DC components from Festo, protection against direct and indirect contact is ensured by means of a sufficiently high IP protection class as well as a protective extra-low voltage supply to the component: PELV "Protective Extra-Low Voltage".

The use of a PELV supply ensures that no contact voltages outside of the permissible range can occur in the event of a fault due to the high dielectric strength (4 kV) from the primary to the secondary side.

The earth terminal therefore is a functional earthing (discharge of electromagnetic disturbances) rather than a protective earth function and must always make contact.

**Why does Festo use protection class III?**

Due to the increasingly compact designs of modern automation components, protection class I is no longer the optimum solution with respect to construction size.

This is because the standards specify minimum distances for the air and leakage paths, which means that a further minimising of the size of the components

is no longer possible.

It is for this reason that protection class III (no protective earth conductor, as protection against electric shock is provided

by protective extra-low voltage) is used in modern automation components.

What do customers need to know about installing equipment in protection class III?

The electrical supply to the equipment must only be provided by PELV circuits to IEC/EN 60204-1. The general requirements for PELV circuits as per IEC/EN 60204-1 must be taken into account.

Power sources are permitted if reliable electrical isolation of the operating voltage to IEC/EN 60204-1 is guaranteed. The earth terminals on the components, where available, are used for discharging

electromagnetic disturbances, equipotential bonding and thus ensuring proper functioning. They must be connected to the earth potential with low resistance (short cables with large cross section).

Spark arresting of switch contacts in circuits incorporating solenoid coils

The inductance of solenoid coils stores electromagnetic energy when the circuit is switched on and this is discharged when switched off. Depending on the

switch used, this energy is either converted to a voltage peak (switch-off over-voltage), which can cause a breakdown in

the insulation, or an arc which can burn away the contacts (material creep). Various types of components can be used to

avoid these effects by slowly and constantly discharging the electromagnetic energy.

Electronic arc arrestors

If the polarity in DC circuits is clearly defined, a simple diode can be used, wired parallel to the coil. It must be noted that this considerably increases the solenoid switch-off time.

A more suitable arrangement consists of two breakdown diodes, wired with opposing polarity parallel to the coil, which can be used for DC and AC. This prevents switch-off delay. However, several breakdown diodes must be wired in series for voltages over 150 V.

Varistors are ideal elements for reducing switch-off overvoltage; their leakage current only rises if the rated voltage is exceeded. They are suitable for DC and AC.

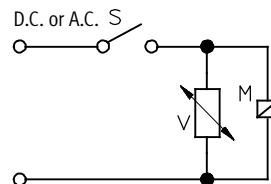
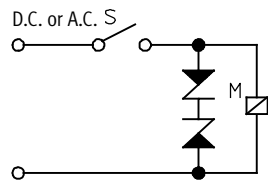
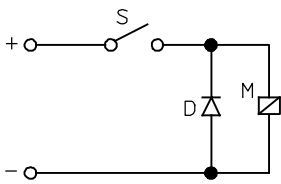

100% duty cycle

Within DIN VDE 0580, the 100% duty cycle test covers only the electrical part of the solenoid coil. Festo also includes the pneumatic part in this test.

The worst-case scenario is reviewed in the test. The test constitutes functional testing of the solenoid. If the solenoid is also used on valve terminals, the 100%

duty cycle test is performed on the individual device and on equipment in a manifold assembly.

Conditions

- The solenoids are operated with the maximum permissible voltage (continuous operation S1 to DIN VDE 0580).
- The solenoids are subjected to the maximum permissible ambient temperature in a temperature cabinet (non-convecting).
- The solenoids are supplied with the maximum permissible operating pressure with sealed working ports.

Procedure

The solenoids are operated for at least 72 hours under the above conditions. At the end of this period, the following tests are carried out:

- Drop-off current measurement: drop-off behaviour when switched to de-energised state.
- Starting behaviour when immediately energised with the minimum operating voltage and with the least favourable pressure ratios for excitation.

- Leakage measurements.
- Once the results have been recorded, this process is repeated again until the units being tested have reached a total duty cycle of at least 1,000 hours or a termination criterion has been fulfilled.
- Following completion of the 100% duty cycle test, the sealing nipples are inspected visually for damage.

Termination criterion

The drop-off behaviour, starting behaviour or leakage exceeds or falls below the following limit values:

- Drop-off current: > 1.0 mA
- Starting voltage: > UN+10%
- Leakage: > 10 l/h

Argentina

Festo S.A.
Edison 2392
(1640) Martínez
Prov. Buenos Aires
Ventas y Asistencia técnica
0810-555-FESTO (33786)
ventas@ar.festo.com
Tel. 0810-444-3127,
Fax +54 (011) 47 17 82 82
E-mail: info@ar.festo.com

Australia

Festo Pty. Ltd.
Head Office (Melbourne)
179-187 Browns Road
P.O. Box 261
Noble Park Vic. 3174
Tel. +61(0)3 97 95 95 55,
Fax +61(0)3 97 95 97 87
E-mail: info_au@festo.com

Austria

Festo Gesellschaft m.b.H.
Linzer Straße 227
1140 Wien
Tel. +43 (0)1 910 75-0,
Fax +43 (0)1 910 75-250
E-mail: automation@festo.at

Belarus

IP Festo
Masherov avenue, 78
220035 Minsk
Tel. +375 (0)17 204 85 58,
Fax +375 (0)17 204 85 59
E-mail: info_by@festo.com

Belgium

Festo Belgium sa/nv
Rue Colonel Bourg 101
1030 Brussel/Bruxelles
Tel. +32 (0)2 702 32 11,
Fax +32 (0)2 702 32 09
E-mail: info_be@festo.com

Brazil

Festo Brasil Ltda
Rua Guiseppe Crespi, 76
Jd. Santa Emília
04183-080 São Paulo / SP -Brasil
Tel. +55 (11) 5013-1600,
Fax +55 (11) 5013-1801
E-mail: linhadireta@br.festo.com

Bulgaria

Festo EOOD
1592 Sofia
Bul. Christophor Kolumb 9
Tel. +359 (0)2 960 07 12,
Fax +359 (0)2 960 07 13
E-mail: info_bg@festo.com

Canada

Festo Inc.
5300 Explorer Drive
Mississauga, Ontario L4W 5G4
Tel. +1 (0)905 624 90 00,
Fax +1 (0)905 624 90 01
E-mail: info_ca@festo.com

Chile

Festo S.A.
Avenida Américo Vespucio, 760
Pudahuel
Santiago
Tel. +56 2 690 28 00,
Fax +56 2 690 28 60
E-mail: info.chile@cl.festo.com

China

Festo (China) Ltd.
1156 Yunqiao Road,
Jinqiao Export Processing Zone,
Pudong,
Shanghai 201206
Tel. +86 21 60 81 51 00,
Fax +86 21 58 54 03 00
E-mail: info_cn@cn.festo.com

Colombia

Festo Ltda.
Autopista Bogotá - Medellín Km 6
(costado sur)
Tenjo, Cundinamarca
Tel. +57 (1) 865 7729,
Fax +57 (1) 865 7729 Ext. 287
E-mail: mercadeo@co.festo.com

Croatia

Festo d.o.o.
Nova Cesta 181
10000 Zagreb
Tel. +385 (0)1 619 19 69,
Fax +385 (0)1 619 18 18
E-mail: info_hr@festo.com

Czech Republic

Festo, s.r.o.
Modřanská 543/76
147 00 Praha 4
Tel. +420 261 09 96 11,
Fax +420 241 77 33 84
E-mail: info_cz@festo.com

Denmark

Festo A/S
Islevdalvej 180
2610 Rødovre
Tel. +45 70 21 10 90,
Fax +45 44 88 81 10
E-mail: info_dk@festo.com

Estonia

Festo OY AB Eesti Filiaal
A.H. Tammsaare tee 118B
12918 Tallinn
Tel. +372 666 1560,
Fax +372 666 15 6
E-mail: info_ee@festo.com

Finland

Festo Oy
Mäkituvantie 9
PL 86
01511 Vantaa
Tel. +358 (09) 87 06 51,
Fax +358 (09) 87 06 52 00
E-mail: info_fi@festo.com

France

Festo Eurl
ZA des Maisons Rouges
8 rue du clos sainte Catherine
94360 Bry-sur-Marne
Tel. +33 (0) 1 48 82 65 00,
Fax +33 (0) 1 48 82 65 01
E-mail: info_fr@festo.com

Germany

Festo AG & Co. KG
Postfach
73726 Esslingen
Ruiter Straße 82
73734 Esslingen
Tel. +49 (0) 711 347 0,
Fax +49 (0) 711 347 2628
E-mail: info_de@festo.com

Greece

Festo Ltd.
92, Tatoiou Ave.
P.C. 144 52 Metamorfosi
Tel. +30 210 341 29 00 - 4,
Fax +30 210 341 29 05
E-mail: info_gr@festo.com

Hong Kong

Festo Ltd.
6/F New Timely Factory Building,
497 Castle Peak Road,
Kowloon, Hong Kong
Tel. + 852 27 43 83 79,
Fax + 852 27 86 21 73
E-mail: info_hk@festo.com

Hungary

Festo Kft.
Csillaghegyi út 32-34.
1037 Budapest
Hotline +36 1 436 51 00
Tel. +36 1 436 51 11,
Fax +36 1 436 51 01
E-mail: info_hu@festo.com

India

Festo Controls Private Ltd.
Festo Controls Pvt. Ltd.
35/3, Shamanna Garden
Bannerghatta Road
Bangalore 560 030
Tel. +91 (0)1800 425 0036,
Fax +91 (0)1800 121 0036
E-mail: sales_in@festo.com

Indonesia

PT. Festo
Jl. Tekno V Blok A/1 Sektor XI
Kawasan Industri BSD
Serpong -Tangerang 15314
Banten - Indonesia
Tel. +62 (0) 21 27 50 79 00,
Fax +62 (0) 21 27 50 79 98
E-mail: sales_id@festo.com

Iran

Festo Pneumatic S.K.
2, 6th street, 16th avenue,
Km 8, Special Karaj Road
P.O.Box 15815-1485
Teheran 1389793761
Tel. +98 (0)21 44 52 24 09,
Fax +98 (0)21 44 52 24 08
E-mail: Mailroom@festo.ir

Ireland

Festo Limited
Unit 5 Sandyford Park
Sandyford Industrial Estate
Dublin 18
Tel. +353 (0)1 295 49 55,
Fax +353 (0)1 295 56 80
E-mail: sales_ie@festo.com

Israel

Festo Pneumatic Israel Ltd.
P.O. Box 1076
Ha'atzma'ut Road 48
Yehud 56100
Tel. +972 (0)3 632 22 66,
Fax +972 (0)3 632 22 77
E-mail: info_il@festo.com

Italy

Festo SpA
Via Enrico Fermi 36/38
20090 Assago (MI)
Tel. +39 02 45 78 81,
Fax +39 02 488 06 20
E-mail: info_it@festo.com

Japan

Festo K.K.
1-26-10 Hayabuchi
Tsuzuki-ku
Yokohama 224-0025
Tel. +81 (0)45 593 5610 / -5611,
Fax +81 (0)45 593 5678
E-mail: info_jp@festo.com

Korea South

Festo Korea Co., Ltd.
Gasam Digital 1-ro
Geumcheon-gu
Seoul #153-803
Tel. +82 1666 0202,
Fax +82 (0)2 864 70 40
E-mail: sales_kr@kr.festo.com

Latvia

Festo SIA
A. Deglava iela 60
1035 Riga
Tel. +371 67 57 78 64,
Fax +371 67 57 79 46
E-mail: info_lv@festo.com

Lithuania

Festo, UAB
Partizanų 63M
50306 Kaunas
Lietuva
Tel. +370 (8)7 32 13 14,
Fax +370 (8)7 32 13 15
E-mail: info_lt@festo.com

Malaysia

Festo Sdn. Berhad
10 Persiaran Industri
Bandar Sri Damansara
Wilayah Persekutuan
52200 Kuala Lumpur
Tel. +60 (0)3 62 86 80 00,
Fax +60 (0)3 62 75 64 11
E-mail: info_my@festo.com

Mexico

Festo Pneumatic, S.A.
Av. Ceylán 3,
Col. Tequesquínahuac
54020 Tlalnepantla
Estado de México
Tel. +52 (01)55 53 21 66 20,
Fax +52 (01)55 53 21 66 55
E-mail: festo.mexico@mx.festo.com

Netherlands

Festo B.V.
Schieweg 62
2627 AN Delft
Tel. +31 (0)15 251 88 99,
Fax +31 (0)15 251 88 67
E-mail: info@festo.nl

New Zealand

Festo Ltd.
20 Fisher Crescent
Mount Wellington
Auckland
Tel. +64 (0)9 574 10 94,
Fax +64 (0)9 574 10 99
E-mail: info_nz@festo.com

Nigeria

Festo Automation Ltd.
Motorways Centre, First Floor, Block C
Alausa, Ikeja,
Lagos
Tel. +234 (0)1 794 78 20,
Fax +234 (0)1 555 78 94
E-mail: info@ng-festo.com

Norway

Festo AS
Ole Deviks vei 2
0666 Oslo
Tel. +47 22 72 89 50,
Fax +47 22 72 89 51
E-mail: info_no@festo.com

Peru

Festo S.R.L.
Amador Merino Reyna 480
San Isidro
Lima
Tel. +51 (1) 219 69 60,
Fax +51 (1) 219 69 71
E-mail: festo.peru@pe.festo.com

Philippines

Festo Inc.
KM 18, West Service Road
South Super Highway
1700 Paranaque City
Metro Manila
Tel. +63 (2) 77 66 888,
Fax +63 (2) 82 34 220/21
E-mail: info_ph@festo.com

Poland

Festo Sp. z o.o.
Janki k/Warszawy
ul. Mszczonowska 7
05090 Raszyn
Tel. +48 (0)22 711 41 00,
Fax +48 (0)22 711 41 02
E-mail: info_pl@festo.com

Portugal

Festo – Automação, Unipessoal, Lda.
Rua Manuel Pinto De Azevedo, 567
Apartado 8013
P-4109601 Porto
Contact Center: 707 20 20 43
Tel. +351 22 615 61 50,
Fax +351 22 615 61 89
E-mail: info@pt.festo.com

Romania

Festo S.R.L.
St. Constantin 17
010217 Bucuresti
Tel. +40(0)21 403 95 00,
Fax +40 (0)21 310 24 09
E-mail: info_ro@festo.com

Russia

OOO Festo-RF
Michurinskiy prosp., 49
119607 Moscow
Tel. +7 495 737 34 00,
Fax +7 495 737 34 01
E-mail: info_ru@festo.com

Singapore

Festo Pte. Ltd.
6 Kian Teck Way
Singapore 628754
Tel. +65 62 64 01 52,
Fax +65 62 61 10 26
E-mail: info@sg.festo.com

Slovakia

Festo spol. s r.o.
Gavlovicová ul. 1
83103 Bratislava 3
Tel. +421 (0)2 49 10 49 10,
Fax +421 (0)2 49 10 49 11
E-mail: info_sk@festo.com

Slovenia

Festo d.o.o. Ljubljana
IC Trzin, Blatnica 8
1236 Trzin
Tel. +386 (0)1 530 21 00,
Fax +386 (0)1 530 21 25
E-mail: info_si@festo.com

South Africa

Festo (Pty) Ltd.
22-26 Electron Avenue
P.O. Box 255
Isando 1600
Tel. +27 (0)11 971 55 00,
Fax +27 (0)11 974 21 57
E-mail: info_za@festo.com

Spain

Festo Pneumatic, S.A.U.
Avenida Granvia, 159
Distrito Económico Granvia L'H
08908 Hospitalet de Llobregat
Barcelona
Tel. +34 901243660,
Fax +34 902243660
E-mail: info_es@festo.com

Sweden

Festo AB
Stillmansgatan 1
Box 21038
200 21 Malmö
Tel. +46 (0)20 38 38 40,
Fax +46 (0)40 38 38 10
E-mail: order@festo.se

Switzerland

Festo AG
Moosmattstrasse 24
8953 Dietikon ZH
Tel. +41 (0)44 744 55 44,
Fax +41 (0)44 744 55 00
E-mail: info_ch@festo.com

Taiwan

Festo Co., Ltd.
Head Office
9, Kung 8th Road
Linkou 2nd Industrial Zone
Linkou Dist., New Taipei City
24450 Taiwan, R.O.C.
Tel. +886 (0)2 26 01-92 81,
Fax +886 (0)2 26 01 92 86-7
E-mail: festotw@tw.festo.com

Thailand

Festo Ltd.
Viranuvat Building, 6th - 7th Floor.
1250 Bangna - Trad Road (Soi 34)
Bangna, Bangkok 10260
Tel. +66 2746-8700,
Fax +66 2746-8370
E-mail: info_th@festo.com

Turkey

Festo San. ve Tic. A.S.
Istanbul Anadolu Yakası Organize Sanayi
Bolgesi
Aydinli Mah. TEM Yan Yol Cad. No:16
34953 Tuzla - Istanbul/TR
Tel. +90 (0)216 585 00 85,
Fax +90 (0)216 585 00 50
E-mail: info_tr@festo.com

Ukraine

DP Festo
ul. Borislebskaya,11
04070, Kiev
Tel. +380 (0)44 233 6451,
Fax +380 (0)44 463 70 96
E-mail: orders_ua@festo.com

United Kingdom

Festo Limited
Applied Automation Centre
Caswell Road
Brackmills Trading Estate
Northampton NN4 7PY
Tel. ++44 (0)1604 / 66 70 00,
Fax ++44 (0)1604 / 66 70 01
E-mail: info_gb@festo.com

United States

Festo Corporation (New York)
395 Moreland Road
P.O. Box 18023
Hauppauge, NY 11788
Call Toll-free 800/993 3786
Fax Toll-free 800/963 3786
Tel. +1(631) 435 08 00,
Fax +1(631) 435 80 26
E-mail: customer.service@us.festo.com

Venezuela

Festo C.A.
Av. 23 esquina con calle 71
N° 22-62, Edif. Festo.
Sector Paraíso
Maracaibo - Venezuela
Tel. +58 (261) 759 11 20/
759 41 20/759 44 38,
Fax +58 (261) 759 04 55
E-mail: festo@festo.com.ve

Vietnam

Festo Co Ltd
(Cong Ty TNHH FESTO)
No. 1515 – 1516 Van Dai Dong Street
Ward An Phu, District 2
Ho Chi Minh City
Tel. +84 (8) 62 81 44 53 – 4454,
Fax +84 (8) 62 81 4442
E-mail: info_vn@festo.com

Type	Page/online	Type	Page/online
CPX, Terminal	677	CRZNG, Trunnion flange for standard cylinder DSBF-C to ISO 15552	60
CPX-CEC, Control block	cpx-cec	CTEC	
CPX-CTEL, Electrical interface	cpx-ctel	– CPI installation system	ctec
CPX-MMI, Operator unit, text-based	cpx-mmi	– Installation system	ctec
CPX-ST, Inscription label holder	cpx-st	CTEL, Installation system	ctel
CPX-AB		CTEU, Fieldbus module	cteu
– Connection block for terminal CPX	715	CTSL, Input module	ctsl
– Connection block for terminal CPX-P	985		
– Manifold block for AS-interface for valve terminal VTSA	639	D	
CPX-AB-2-M12-RK		D	
– Fieldbus connection for terminal CPX	713	– EduTrainer®	edutrain
– Fieldbus connection for terminal CPX-P	984	– Reducing nipple	d-1
CPX-AB-S-4-M12		DADE, Measured-value transducer	dade
– Screening plate for terminal CPX	715	DADL-EL, Clamping unit for semi-rotary drive DRRD	188
– Screening plate for terminal CPX-P	985	DADS, Cover for mini slide DGSL	257
CPX-BG-RW		DAMD, Blanking screw for standard cylinder DSBF to ISO 15552	60
– Wall mounting for terminal CPX	717	DAMS, Swivel flange for electric cylinder ESBF	310
– Wall mounting for terminal CPX-P	987	DAMT	
CPX-CEC		– Trunnion mounting kit for electric cylinder DNCE	318
– Control block, For terminal CPX	cpx-cec	– Trunnion mounting kit for standard cylinder DSBC to ISO 15552	42
– Control block for terminal CPX	712	– Trunnion mounting kit for standard cylinder to ISO 15552	68
CPX-CM-HPP, FHPP gateway for terminal CPX	714	DAPS, Quarter turn actuator, Sypar	daps
CPX-CMAX, Axis controller	cpx-cmax	DAPZ, Limit switch attachments	dapz
CPX-CMIX, Measuring module	cpx-cmix	DASI-KT, Sensing kit for semi-rotary drive DRRD	188
CPX-CMPX, End-position controller for Soft Stop	cpx-cmpx	DASP-M4-125-A, Sensor bracket, for proximity sensors for T-slot	743
CPX-CMXX, Control block, For terminal CPX	cpx-cmxx	DAYH, Reducing sleeve for mini slide DGSL	256
CPX-CP, CP interface for terminal CPX	714	DDL1, Linear drive, integrated displacement encoder	ddli
CPX-CPA-BG-NRH		DDPC, Standard cylinder, integrated displacement encoder	ddpc
– H-rail mounting for terminal CPX	717	DFC, Mini guided drive	dfc
– H-rail mounting for terminal CPX-P	987	DFK, Flanged cylinder, double-acting	dfk
CPX-CTEL, I-Port interface for terminal CPX	714	DFM, Guided drive	271
CPX-EP		DFME-LAS, Guided drive	dfme-las
– End plate for terminal CPX	716	DFP, Guided drive, double-acting	dfp
– End plate for terminal CPX-P	986	DFPB, Quarter turn actuator, for process automation	dfpb
CPX-EPFE-EV, Earthing component for terminal CPX	712	DFPI, Linear drive, with displacement encoder	dfpi
CPX-FB		DFST, Stopper cylinder	dfst
– Bus node for terminal CPX-P	984	DG, Round cylinder, double-acting, miniature cylinder	dg
– Fieldbus node for terminal CPX	712	DGC-FA, Passive guide axis	dgc-fa
CPX-FEC, Control block for terminal CPX	712	DGC-G, Linear drive, basic design	143
CPX-GE-EV, Interlinking block for terminal CPX	716	DGC-GF, Linear drive with plain-bearing guide	143
CPX-M-GE-EV, Interlinking block for terminal CPX-P	986	DGC-HD, Linear drive with heavy-duty guide	171
CPX-MMI-1, Operator unit for terminal CPX	687	DGC-KF, Linear drive with recirculating ball bearing guide	143
CPX-P, Terminal	968	DGCI, Linear drive, with displacement encoder	dgc
CPX-SK		DGE-SP	
– Memory card for terminal CPX	717	– Spindle axis with recirculating ball bearing guide	dge-sp
– Memory card for terminal CPX-P	987	– Spindle axis without guide	dge-sp
CPX-W-PT1000, Temperature sensor for terminal CPX	717	DGE-ZR, Toothed belt axis without guide	dge-zr
CPX-ZA, Tie rod for terminal CPX	712	DGE-ZR-HD, Toothed belt axis with heavy-duty guide, recirculating ball bearing guide	dge-zr
CQ, Push-in fitting	n_36446	DGE-ZR-KF, Toothed belt axis with recirculating ball bearing guide	dge-zr
CRCN, Barbed fitting, stainless steel	crcn	DGE-ZR-RF, Toothed belt axis with roller guide	dge-zr
CRDNG, Standard cylinder, corrosion-resistant	crdng	DGEA-ZR, Cantilever axis with recirculating ball bearing guide	dgea
CRDNGS, Standard cylinder, corrosion-resistant	crdngs	DGO, Linear drive, magnetic force transmission	dgo
CRDSNU		DGP, Linear drive, basic design	dgp
– Round cylinder, stainless steel	crdsnu	DGPI, Linear drive, with displacement encoder	dgpi
– Standard cylinder, corrosion-resistant	crdsnu	DGPIL, Linear drive, with displacement encoder	dgpil
CRFNG, Flange mounting for standard cylinder DSBF-C to ISO 15552	60	DGPL, Linear drive, with guide	dgpl
CRHD, Round cylinder, double-acting, stainless steel	crhd	DGRF, Guided drive, Clean Design	dgrf
CRHNC, Foot mounting for standard cylinder DSBF-C to ISO 15552	60	DGSL, Mini slide	250
CRLNG, Clevis foot for standard cylinder DSBF-C to ISO 15552	60	DHDS, Three-point gripper	488
CRLNZG, Trunnion support for standard cylinder DSBF-C to ISO 15552	60	DHEB, Bellows gripper	dheb
CRO, Sealing ring	937	DHPS, Parallel gripper	483
CRQS, Push-in fitting, stainless steel	crqs	DHRS, Radial gripper	497
CRSG, Rod clevis for standard cylinder DSBF-C to ISO 15552	60	DHSL, Linear gantry	dhs
CRSGS, Rod eye for standard cylinder DSBF-C to ISO 15552	60	DHSR, Three-dimensional gantry	dhsr
CRSMB-8, Mounting kit, corrosion resistance, for T-slot	743	DHTG, Rotary indexing table	dhgt
CRSMBR, Mounting kit for proximity sensor, for round cylinder DSNU/ESNU	100	DHWS, Angle gripper	492
CRSMEO-4, Proximity sensor, corrosion-resistant, round design	crsmeo-4	DLP, Linear actuator, Copac	dlp
CRSMT-8, Proximity sensor for T-slot, magneto-resistive, corrosion resistant	crsmt-8	DMES, Positioning axis	dmes
CRVZS, Air reservoir	993	DMM, Multimount cylinder, double-acting	dmm

Type	Page/online	Type	Page/online
DMML, Multimount cylinder, double-acting, non-rotating	dmml	DZH, Flat cylinder, double-acting	dzh
DMSP, Fluidic muscle, with press-fitted connection	dmsp	E	
DNC, Standard cylinder to ISO 15552 (ISO 6431 and VDMA 24562), double-acting	63	E, Double nipple	e-1
DNC-KP, Standard cylinder, with clamping unit	dnc-kp	EADC, Compensating component for electric cylinder DNCE	319
DNC-V, Standard cylinder, cylinder/valve combination	dnc-v	EAGF, Guide unit	eagf
DNCE, Electric cylinder with piston rod	314	EAHA, Adapter kit for electric cylinder EPCO	302
DNCE-LAS, Electric cylinder	dnce-las	EAHF	
DNCI, Standard cylinder, with displacement encoder	dnci	– Foot mounting for electric cylinder EPCO	302
DNCKE, Cylinder, with clamping unit	dncke	– Profile mounting for electric cylinder DNCE	319
DNCKE-S, Cylinder, with clamping unit, safety component	dncke-s	– Profile mounting for electric cylinder ESBF	311
DNCT, Tandem cylinder, standard hole pattern	dnct	– Profile mounting for mini slide EGSL	368
DNG, Standard cylinder, to ISO 15552	dng	EAHH	
DNGZK, Standard cylinder, to ISO 15552	dngzk	– Flange mounting for electric cylinder EPCO	302
DNGZS, Standard cylinder, to ISO 15552	dngzs	– Flange mounting for electric cylinder ESBF	311
DPA, Pressure booster	dpa	EAHS, Swivel mounting for electric cylinder EPCO	302
DPA-MA-SET, Pressure gauge kit for pressure booster DPA	dpa	EAMB, Drive shaft for toothed belt axis EGC-TB	349
DPNA, Multi-position kit for compact cylinder to ISO 21287	114	EAMC, Coupling	eamc
DPNC		EAMD, Coupling	eamd
– Multi-position kit for short-stroke cylinder ADVC/AEVC	132	EAMM-A	
– Multi-position kit for standard cylinder DSBC to ISO 15552	43	– Axial kit for electric cylinder DNCE	322
– Multi-position kit for standard cylinder DSBG to ISO 15552	53	– Axial kit for electric cylinder ESBF	312
– Multi-position kit for standard cylinder to ISO 15552	67	– Axial kit for mini slide EGSL	367
DPZ, Twin-piston cylinder, with guide	dpz	– Axial kit for rotary/lifting module EHMB	400
DPZJ, Twin cylinder, with guide, with two yoke plates	dpzj	– Axial kit for spindle axis EGC-BS	329
DRD, Quarter turn actuator, Copar, double-acting	drd	– Axial kit for spindle axis EGC-HD-BS	339
DRE, Quarter turn actuator, Copar, single-acting	dre	– Axial kit for toothed belt axis EGC-HD-TB	358
DRQ, Semi-rotary drive	drq	– Axial kit for toothed belt axis EGC-TB	348
DRQD, Semi-rotary drive	224	– Axial kit for toothed belt axis ELGA-TB	379
DRQD-B, Semi-rotary drive	224	– Axial kit for toothed belt axis ELGR	387
DRRD, Semi-rotary drive	181	EAMM-U	
DSBC, Standard cylinder to ISO 15552 (ISO 6431 and VDMA 24562), double-acting	35	– Parallel kit for electric cylinder DNCE	320
DSBF-C, Standard cylinder to ISO 15552 (ISO 6431 and VDMA 24562), double-acting, Clean Design	56	– Parallel kit for electric cylinder ESBF	312
DSBG, Standard cylinder to ISO 15552 (ISO 6431 and VDMA 24562), double-acting	46	– Parallel kit for mini slide EGSL	367
DSL-B, Swivel/linear drive unit	dsl	– Parallel kit for rotary/lifting module EHMB	401
DSM...-B, Cushioning mount for swivel module DSM-B	213	– Parallel kit for spindle axis EGC-BS	329
DSM...-P-B, Cushioning kit for swivel module DSM-B	213	– Parallel kit for spindle axis EGC-HD-BS	339
DSM-B, Swivel module	205	EAPM	
DSM-FF		– Sensor bracket for toothed belt axis ELGA-TB	379
– Adapter for stop kit KSM, for swivel module DSM	198	– Sensor bracket for toothed belt axis ELGR	387
– Adapter for mounting kit WSM, for swivel module DSM	198	– Switch lug for mini slide EGSL	369
DSM-T-B, Swivel module with tandem rotary vanes	205	– Switch lug for toothed belt axis ELGA-TB	379
DSMI, Swivel module, with displacement encoder	dsmi	– Switch lug for toothed belt axis ELGR	387
DSN, Standard cylinder to ISO 6432, double-acting	71	EAPS, Cam for rotary/lifting module EHMB	405
DSNU		EAPS...-CK, Cam for rotary module ERMB	391
– Round cylinder, double-acting	91	EAPS...-H, Housing for rotary module ERMB	391
– Standard cylinder to ISO 6432, double-acting	71	EAPS...-S, Sensing kit for rotary module ERMB	391
DSNUP, Standard cylinder to ISO 6432, double-acting	71	EAPS...-S-WH, Sensing kit without housing for rotary module ERMB	391
DSR, Semi-rotary drive, with spigot shaft	dsr	EAPS...-SH, Sensor bracket for rotary module ERMB	391
DSRL, Semi-rotary drive, with hollow flanged shaft	dsrl	EASA, Protective conduit fitting EASA for rotary/lifting module EHMB	405
DW, Hinge cylinder	dw	EASC	
DWA, Hinge cylinder	dwa	– Cover for mini slide EGSL	367
DWB, Hinge cylinder	dwb	– Cover for rotary/lifting module EHMB	405
DWC, Hinge cylinder	dwc	EASC...-F, Cover for mini slide EGSL	367
DYEF		EAYH	
– Shock absorber	dyef	– Retainer for spindle axis EGC-HD-BS	338
– Shock absorber for mini slide DGSL	256	– Retainer for toothed belt axis EGC-HD-TB	358
– Shock absorber for swivel module DSM-B	213	– Shock absorber retainer for rotary/lifting module EHMB	405
DYEF-S, Shock absorber for mini slide DGSL	256	EHAM, Adapter plate kit for rotary/lifting module EHMB	405
DYHR, Hydraulic cushioning cylinder	dyhr	EB, Bellows actuator, bellows	eb
DYSC		EBS, Bellows actuator, rolling bellows	ebs
– Shock absorber	dysc	EFK, Flanged cylinder, single-acting	efk
– Shock absorber for swivel module DSM-B	213	EG, Round cylinder, single-acting, miniature cylinder	eg
DYSR, Shock absorber	dysr	EG-PK, Round cylinder, single-acting, micro cylinder	eg-pk
DYSW		EGC-FA, Passive guide axis	egc
– Shock absorber	dysw	EGC-BS-KF, Spindle axis with recirculating ball bearing guide	324
– Shock absorber for mini slide DGSL	256	EGC-HD-BS, Spindle axis with heavy-duty guide	334
– Shock absorber for rotary/lifting module EHMB	405	EGC-HD-TB, Toothed belt axis with heavy-duty guide	354
DZF, Flat cylinder, double-acting	dzf	EGC-TB-KF, Toothed belt axis with recirculating ball bearing guide	344

Type	Page/online	Type	Page/online
FWSR		HGPD, Parallel gripper	hgpd
– Push-on flange for swivel module DSM	198	HGPL, Parallel gripper	hgpl
– Push-on flange for swivel module DSM-B	213	HGPLE, Parallel gripper, sturdy with long stroke, electric	hgple
G		HGPM, Parallel gripper	hgpm
G, Elbow	g-m5	HGPP, Parallel gripper	hgpp
GF, Rotary distributor	gf	HGPT-B, Parallel gripper	hgpt
GFDM, Diagnostic module, software	gfdm	HGRC, Radial gripper	hgrc
GG, One-way flow control valve	gg	HGRT, Radial gripper	hgtr
GGO, One-way flow control valve	gg	HGWC, Angle gripper	hgwc
GR, in-line installation		HGWM, Angle gripper	hgwm
– One-way flow control valve with female thread	gr	HMBN, Slot nut for linear drive DGC	154
– One-way flow control valve with push-in connector QS	gr	HMP, Linear module	hmp
GRA, in-line installation, One-way flow control valve with female thread	gr	HMZAS, Installation kit for protective conduits	hmzas
GRE		HMZV, Junction box, for protective conduits	hmzv
– Exhaust air flow control valve	gru	HNA, Foot mounting for compact cylinder to ISO 21287	114
– Flow control/silencer combination	gru	HNC	
GRF, One-way flow control valves for mounting frame 2N	m5 compact	– Foot mounting for electric cylinder DNCE	318
GRGO, mini, Flow control valve with push-in connector QS	grlo	– Foot mounting for electric cylinder ESBF	310
GRLA, One-way flow control valve, standard	611	– Foot mounting for short-stroke cylinder ADVC/AEVC	131
GRLO, mini		– Foot mounting for standard cylinder DSBG to ISO 15552	41, 50
– Flow control valve with female thread	grlo	– Foot mounting for standard cylinder to ISO 15552	67
– Flow control valve with push-in connector QS	grlo	HMCE, Foot mounting for electric cylinder DNCE	318
GRLO, standard		HPC, Foot mounting for linear drive DGC	154
– Flow control valve with barbed connector	grlo	HPE	
– Flow control valve with female thread	grlo	– Foot mounting for spindle axis EGC-BS	328
GR LZ, One-way flow control valve, standard	611	– Foot mounting for toothed belt axis EGC-TB	350
GR0, in-line installation		– Foot mounting for toothed belt axis ELGA-TB	380
– Flow control valve with female thread	gro	HPV, Feed separator	hpv
– Flow control valve with push-in connector QS	gro	HPVS, Feed separator	hpvs
GRP, Precision one-way flow control valve	grp	HSM, Mounting plate for swivel module DSM-B	213
GRPO, Precision flow control valve	grpo	HSP, Handling module	hsp
GRR, One-way flow control valve	gg	HSW-AE, Handling module, electric	hsw
GRU, Flow control/silencer	gru	HSW-AP, Handling module, pneumatic	hsw
GRXA-HG, One-way flow control valve	grxa-hg	HSW-AS, Handling module, without drive	hsw
GSIB, Operator package, software	gsib	HW, Selector switch, 3/6-way valve	hw
GSLO, Software licence	gslo	HWF, Inscription label	hwf
GSPP, Software	gspp	HWS-EGC	
GSWF-P5, Software, FluidDraw S5®	gswf	– Sensor bracket for linear drive DGC-HD with heavy-duty guide	175
GSWF-S5, Software, FluidDraw S5®	gswf	– Sensor bracket for spindle axis EGC-BS	328
GWB, Thread sealing tape	938	– Sensor bracket for spindle axis EGC-HD-BS	338
		– Sensor bracket for toothed belt axis EGC-HD-TB	358
		– Sensor bracket for toothed belt axis EGC-TB	348
H		I	
H		IBS	
– Finger lever valve, 4/3-way valve	h-4/3	– Inscription label	ibs
– Hand lever valve, 3/2-way valve	n_v14	– Inscription label for valves, to ISO 15407-1	548
– Hand lever valve, 5/2-way valve	n_v14	IBS-6x10	
– Non-return valve with female/male thread	h-qs	– Inscription label for terminal CPX	714
– Non-return valve with push-in connector QS	h-qs	– Inscription label for terminal CPX-P	985
– Toggle lever valve, 5/3-way valve	h-5/3	– Inscription label for valve terminal MPA-L	672
HA, Non-return valve	h-qs	IBT, Inscription label holder	ibt
HAB, Manual override, for non-return valve HGL	hab	ISK, Cover cap	isk
HB, Non-return valve	h-qs	ISV, Vacuum security valve	isv
HBN		J	
– Foot mounting for round cylinder DSNU/ESNU	99	J	
– Foot mounting for standard cylinder to ISO 6432	85	– 5/2-way valve, midi pneumatic	n_mdp
HE		– 5/2-way valve, pneumatic valve, to ISO 5599-1	iso 5599-1
– On-off valve, D series, metal	he	– Double pilot valve 5/2-way for mounting frame 2N	m5 compact
– Shut-off valve	he	J-B, 5/2-way valve, Tiger 2000	tiger 2000
HE-LO, Shut-off valve	he-lo	JD	
HEE, On-off valve, D series, metal	hee	– 5/2-way valve, pneumatic valve, to ISO 5599-1	iso 5599-1
HEL, Soft-start valve, D series, metal	hel	– Double pilot valve 5/2-way for mounting frame 2N	m5 compact
HEP, On-off valve, D series, metal	hep	JMEBH, Double solenoid valve, to ISO 5599-1	549, 553, 562
HGDD, Three-point gripper	hgdd	JMEH, 5/2-way valve, midi pneumatic	n_mdp
HGDS, Swivel/gripper unit	hgds	JMEBH, 5/2-way valve, midi pneumatic	n_mdp
HGDT, Three-point gripper	hgdt	JMFH, Solenoid valve for mounting frame 2N	m5 compact
HGL, Non-return valve, piloted	608	JMFH-B, Double solenoid valve, Tiger 2000	tiger 2000
HGP, Parallel gripper	hgp		
HGPC, Parallel gripper	hgpc		

Type	Page/online	Type	Page/online
– Trunnion support for compact cylinder to ISO 21287	114	MEB, Illuminating seal for plug type C, to ISO 15407-1	548
– Trunnion support for electric cylinder DNCE	310, 318	MEB-LD, Illuminating seal	n_mc_ld
– Trunnion support for electric cylinder EPCO	302	MEBH	
– Trunnion support for short-stroke cylinder ADVC/AEVC	131	– 3/2-way valve, midi pneumatic	n_mdp
– Trunnion support for standard cylinder DSBG to ISO 15552	41, 50	– 5/2-way valve, midi pneumatic	n_mdp
– Trunnion support for standard cylinder to ISO 15552	67	– 5/2-way valve, to ISO 5599-1	549
LO, Roller lever valve with idle return, 3/2-way valve	lo-3	– 5/3-way valve, midi pneumatic	n_mdp
LOE, Lubricator, D series, metal	loe	– 5/3-way valve, to ISO 5599-1	549
LOS, Roller lever valve with idle return, 3/2-way valve	los-3	MEH	
LPZ, Air nozzle	lpz	– 3/2-way valve, midi pneumatic	n_mdp
LQG		– 5/2-way valve, midi pneumatic	n_mdp
– Right-angle clevis foot for compact cylinder to ISO 21287	115	– 5/3-way valve, midi pneumatic	n_mdp
– Right-angle clevis foot for electric cylinder DNCE	310, 318	MF-LD	
– Right-angle clevis foot for electric cylinder EPCO	302	– Illuminating seal	n_mc_ld
– Right-angle clevis foot for round cylinder DSNU/ESNU	101	– Illuminating seal for F solenoid coil	607
– Right-angle clevis foot for short-stroke cylinder ADVC/AEVC	132	MFH	
– Right-angle clevis foot for standard cylinder DSBC to ISO 15552	42	– 5/2-way valve, to NAMUR	namur
– Right-angle clevis foot for standard cylinder DSBG to ISO 15552	51	– Solenoid valve for mounting frame 2N	m5 compact
– Right-angle clevis foot for standard cylinder to ISO 15552	68	MFH-B	
LR, Pressure regulator, D series, metal	lr	– 5/2-way valve, Tiger 2000	tiger 2000
LR-DB, Pressure regulator, D series, polymer	lr-db	– 5/3-way valve, Tiger 2000	tiger 2000
LR-G, Pressure regulator	lr-g	MFHE, Solenoid valve	mfhe
LR-QS, Pressure regulator	lr-qs	MFL, Indicator insert	mfl
LRB, Pressure regulator, D series, metal	lrb	MFLZ, Indicator insert	mflz
LRB-DB, Pressure regulator combination, D series, polymer	lrb-db	MFZ, Time delay insert	mfz
LRB-K, Pressure regulator, manifold combination, D series, metal	lrb	MGTBH	
LRBS, Pressure regulator, D series, metal	lrbs	– 5/2-way valve, to NAMUR	namur
LRL, Differential pressure regulator	lrl	– Solenoid valve to Namur	iso 15218
LRL.L, Differential pressure regulator	lrl	MGXIAH, Solenoid valve to Namur	iso 15218
LRMA-QS, Pressure regulator	lrma	MH, Inscription label	mh
LRP, Precision pressure regulator	lrp	MH1	
LRPS, Precision pressure regulator	lrps	– Solenoid valve, miniature	mh1
LRS, Pressure regulator, D series, metal	lrs	– Valve terminal	mh1
LRS-G, Pressure regulator	lrs-g	MHA2-M1H, Sub-base valve without electronics, fast-switching valve	mh2
LRVS-D, Padlock for MS series	891	MHA2-MS1H, Sub-base valve with electronics, fast-switching valve	mh2
LS		MHA3-M1H, Sub-base valve without electronics, fast-switching valve	mh2
– Roller lever valve with idle return, 3/2-way valve	ls-3	MHA3-MS1H, Sub-base valve with electronics, fast-switching valve	mh2
– Roller lever valve with idle return, 4/2-way valve	ls-4	MHA4-M1H, Sub-base valve without electronics, fast-switching valve	mh2
LSN		MHA4-MS1H, Sub-base valve with electronics, fast-switching valve	mh2
– Clevis foot	lsn	MHAP-PI, Electrical plug-in base	mhap
– Clevis foot for electric cylinder DNCE	310, 318	MHE2-M1H, In-line valve without electronics, fast-switching valve	mh2
– Clevis foot for short-stroke cylinder ADVC/AEVC	132	MHE2-MS1H, In-line valve with electronics, fast-switching valve	mh2
– Clevis foot for standard cylinder DSBG to ISO 15552	41, 50	MHE3-M1H, In-line valve without electronics, fast-switching valve	mh2
– Clevis foot for standard cylinder to ISO 15552	68	MHE3-MS1H, In-line valve with electronics, fast-switching valve	mh2
LSNG		MHE4-M1H, In-line valve without electronics, fast-switching valve	mh2
– Clevis foot for electric cylinder DNCE	310, 318	MHE4-MS1H, In-line valve with electronics, fast-switching valve	mh2
– Clevis foot for short-stroke cylinder ADVC/AEVC	132	MHJ10, Solenoid valve	mhj9
– Clevis foot for standard cylinder DSBG to ISO 15552	41, 50	MHJ9, Solenoid valve	mhj9
– Clevis foot for standard cylinder to ISO 15552	67	MHJ9-KMH, Connecting cable	mhj9-kmh
LSNSG		MHP1	
– Clevis foot for electric cylinder DNCE	310, 318	– 2/2-way valve, semi in-line valve, miniature	mh1
– Clevis foot for short-stroke cylinder ADVC/AEVC	132	– 3/2-way valve, semi in-line valve, miniature	mh1
– Clevis foot for standard cylinder DSBG to ISO 15552	41, 50	MHP2-M1H, Semi in-line valve without electronics, fast-switching valve	mh2
– Clevis foot for standard cylinder to ISO 15552	67	MHP2-MS1H, Semi in-line valve with electronics, fast-switching valve	mh2
LSP, Low consumption air gun	lsp	MHP3-M1H, Semi in-line valve without electronics, fast-switching valve	mh2
LT, Pneumatic terminal	lt	MHP3-MS1H, Semi in-line valve with electronics, fast-switching valve	mh2
LTE, End clamp	lte	MHP4-M1H, Semi in-line valve without electronics, fast-switching valve	mh2
LTV, Distributor	ltv	MHP4-MS1H, Semi in-line valve with electronics, fast-switching valve	mh2
M		MK, Protective metal conduit	mk
MA-EN, Pressure gauge	ma	MKA, Adapter connector, for protective conduits	mka
MAP, Precision pressure gauge	map	MKG, Protective conduit	mkg
MAS, Fluidic muscle, with screwed connection	mas	MKGV, Protective conduit fitting	mkgv
MC, Illuminating seal for N1 solenoid coil, to ISO 5599-1	567	MKR	
MC-LD, Illuminating seal	n_mc_ld	– Protective conduit	mkr
MCL, Indicator insert	mcl	– Protective conduit for rotary/lifting module EHMB	405
MCLZ, Indicator insert	mclz	MKRL, Elbow connector for protective conduit	mkr1
MDH-3/2..., MD-3/2...EX, Standard valve with square plug, type A	iso 15218	MKV, Protective conduit	mkv
ME-LD, Illuminating seal	n_mc_ld	MKY, Y-distributor, for protective conduits	mky
		MLO-POT-LWG, Displacement encoder	mlo

Type	Page/online	Type	Page/online
MLO-POT-TLF, Displacement encoder	mlo	MSB, Service unit combination, MS series	814
MME-MTS-TLF, Displacement encoder	mme	MSB-FRC, Service unit, MS series	825
MN1H		MSF, F solenoid coil, for valves to ISO 5599-1	569
– 5/2-way valve, to ISO 5599-1	549	MSFG, F solenoid coil for Tiger Classic valve	607
– 5/2-way valve, to NAMUR	namur	MSFW, F solenoid coil for Tiger Classic valve	607
– 5/3-way valve, to ISO 5599-1	549	MSN1, N1 solenoid coil, for valves to ISO 5599-1	569
MN1H-2, 2/2-way valve	mn1h-2	MSSD	
MN2H-BZT, Inscription label holder	mn2h-bzt	– Plug socket	mssd
MOEBH, 3/2-way valve, midi pneumatic	n_mdp	– Plug socket for F solenoid coil	607
MOEH, 3/2-way valve, midi pneumatic	n_mdp	– Plug socket for N1 solenoid coil, to ISO 5599-1	567
MPA, Valve terminal type 32	mpa-s	MTR-DCI, Motor unit	434
MPA-F, Valve terminal	mpa-f	MTR-STE, Stepper motor	mtre
MPA-L, Valve terminal MPA-L	661	MUC, Profile mounting for linear drive DGC	154
MPPE, Proportional pressure regulator, 3-way pressure regulator	mppe	MUE	
MPPE-3-B, Angled socket	mppe-3-b	– Profile mounting for mini slide EGSL	368
MPPEs, Proportional pressure regulator, 3-way pressure regulator	mppes	– Profile mounting for spindle axis EGC-BS	328
MPYE		– Profile mounting for spindle axis EGC-HD-BS	338
– Proportional directional control valve	mpye	– Profile mounting for toothed belt axis EGC-HD-TB	359
– Proportional directional control valve, 5/3-way valve	mpye	– Profile mounting for toothed belt axis EGC-TB	350
MS-AEND, Mounting plate for MS series	889	– Profile mounting for toothed belt axis ELGA-TB	380
MS-AG, Connecting plate for MS series	889	MUFH, Solenoid valve for mounting frame 2N	m5 compact
MS-AMV, Module connector for MS series	892	MV-LD, Illuminating seal	n_mc_ld
MS-ARMV, Module connector for MS series	892	MVH-BZ, Inscription label holder	mvh-bz
MS-DL, Soft-start valve, MS series	870	MVH-B	
MS-EE, On-off valve, MS series	862	– 5/2-way valve, Tiger 2000	tiger 2000
MS-EM, On-off valve, MS series	855	– 5/3-way valve, Tiger 2000	tiger 2000
MS-EM1, On-off valve, MS series	855		
MS-END, Cover cap for MS series	889	N	
MS-FRM, Branching module, MS series	882	N, Barbed fitting	n_070302f
MS-LFP-C, Filter cartridge for MS series	892	N-MS, Female hose connector	n_cnp
MS-LFP-E, Filter cartridge for MS series	892	N-P, Female hose connector	n_cnp
MS-LFR, Filter regulator, MS series	828	NAS	
MS-LR, Pressure regulator, MS series	839	– Individual sub-base, ports at side, to ISO 5599-1	567
MS-LRB, Pressure regulator, MS series	849	– Individual sub-base, to ISO 15407-1	547
MS-MV, Module connector for MS series	889	NAU, Individual sub-base, ports underneath, to ISO 5599-1	567
MS-MVM, Module connector for MS series	889	NAV, Manifold sub-base, to ISO 5599-1	568
MS-RMV, Module connector for MS series	892	NAW, Manifold sub-base, to ISO 15407-1	547
MS-SV-C, Soft start/quick exhaust valve, MS series	875	NDV, Blanking plate for vacant position, to ISO 15407-1	547
MS-SV-MH, Cover for MS series	891	NEBC	
MS-SV-MK, Cover for MS series	891	– Connecting cable	nebc
MS-WB, Mounting bracket for MS series	889	– Connecting cable for motor controller CMMO-ST	462
MS-WBM, Mounting bracket for MS series	889	– Control cable for motor controller CMMD-AS	449
MS-WP, Mounting bracket for MS series	889	– Control cable for motor controller CMMO-ST	462
MS-WPB, Mounting bracket for MS series	889	– Control cable for motor controller CMMS-AS	453, 458
MS-WPE, Mounting bracket for MS series	889	– Control cable for motor controller CMMS-ST	466
MS-WPM, Mounting bracket for MS series	889	NEBC-M9W5, Connecting cable for terminal CPX	715
MS-WR, Mounting bracket for MS series	889	NEBM	
MS-WRS, Hex nut for MS series	889	– Encoder cable	nebm
MS12-DE, Soft-start valve, MS series	ms12-de	– Encoder cable for motor controller CMMO-ST	304, 462
MS12-LF, Filter, MS series	ms12-lf	– Encoder cable for servo motors	429
MS12-LFM, Fine and micro filter, MS series	ms12-lfm	– Encoder cable for stepper motors	443
MS12-LFX, Activated carbon filter, MS series	ms12-lfx	– Motor cable for motor controller CMMO-ST	461
MS12-LOE, Lubricator, MS series	ms12-loe	– Motor cable for servo motor	429
MS4/MS6-DE, Soft-start valves, MS series	ms4-de	– Motor cable for stepper motor	304, 443
MS4/MS6-FRM-FRZ, Distributor block, MS series	ms4-frz	– Resolver cable for sensor motors	429
MS4/MS6-LDM1, Membrane air dryer, MS series	ms4-ldm1	NEBP, Connecting cable	nebp
MS4/MS6-LF, Filter, MS series	ms4-lf	NEBS, Connecting cable	nebs
MS4/MS6-LFM, Fine and micro filter, MS series	ms4-lfm	NEBU	
MS4/MS6-LFX, Activated carbon filter, MS series	ms4-lfx	– Connecting cable	949
MS4/MS6-LOE, Lubricator, MS series	ms4-loe	– Connecting cable for solenoid valve VSVA, to ISO 15407-1	548
MS4/MS6/MS12-LWS, Water separator, MS series	ms6-lws	NEBV, Connecting cable	nebv
MS6-LRE, Electrical pressure regulator, MS series	ms6-lre	NEBV-S1, Connecting cable	nebv
MS6-LRP, Precision pressure regulator, MS series	ms6-lrp	NEBV-H1G2, Plug socket with cable for E-box VAVE	595
MS6-LRPB, Precision pressure regulator, MS series	ms6-lrpb	NEBV-S1G25-K, Connecting cable for valve terminal VTUG	660
MS6-SV, Soft start/quick exhaust valve, MS series	ms6-sv	NEBV-S1G44-K, Connecting cable for valve terminal VTUG	660
MS9-LF, Filter, MS series	ms9-lf	NEBV-S1W37, Connecting cable for multi-pin plug connection, valve terminal VTSA	640
MS9-LFM, Fine and micro filter, MS series	ms9-lfm	NECA, Multi-pin plug socket	neca
MS9-LFX, Activated carbon filter, MS series	ms9-lfx	NECC	
MS9-LOE, Lubricator, MS series	ms9-loe		

Type	Page/online	Type	Page/online
– Encoder plug for motor controller CMMD-AS	449	OL-S1, Sealing ring assortment	937
– Encoder plug for motor controller CMMF-AS	458	OS, OR gate	os
– Encoder plug for motor controller CMMS-AS	453	OVEM, Vacuum generator, metric	ovem
– Encoder plug for motor controller CMMS-ST	466		
– Plug for controllers CECC	967	P	
– Plug, for controllers	necc	P, Rubber hose	p
NECU, Plug	necu	P.BE-CPX	
NECU-FC, Plug connector for valve terminal MPA-L	676	– Manual for terminal CPX	718
NECU-G78		– User documentation for terminal CPX-P	987
– Power supply for terminal CPX	717	P.BE-MPA-L, Manual for valve terminal MPA-L	676
– Power supply for terminal CPX-P	987	P.BP, Operator package, software	software
NECU-M		P.SW, Software and manual	software
– Fieldbus connection for terminal CPX	713	PAGN	
– Fieldbus connection for terminal CPX-P	984	– Pressure gauge	pagn
NEDU		– Pressure gauge for regulator plate VABF	638
– Multi-pin plug distributor	nedu	PAL, Manifold rail for Tiger Classic valve	607
– Push-in T-connector	nedu	PAN	
NEFC, Connection block for motor controller CMMO-ST	462	– Plastic tubing	pan
NEFU, Cable socket	nefu	– Tubing cutter	zds
NEKM, Plug assortment	nekm	PAN-R, Plastic tubing, for high pressure range	pan-r
NEV		PAN-VO, Plastic tubing, flame-retardant	pan-v0
– End plate kit, to ISO 15407-1	547	PB, Tubing strap	pb
– End plate kit, to ISO 5599-1	568	PCBC, Soldering base	pcbc
NPAW, Tubing support	npaw	PCN, Plastic tubing	pcn
NPE		PDAD, Adsorption dryer	pdad
– Emergency buffer for spindle axis EGC-BS	328	PELV, Protective extra-low voltage	1052
– Emergency buffer for spindle axis EGC-HD-BS	338	PEN	
– Emergency buffer for toothed belt axis EGC-HD-TB	358	– Differential pressure switch	pen
– Emergency buffer for toothed belt axis EGC-TB	348	– Plastic tubing, standard O.D., Resistant to cleaning agents	903
NPFA, Adapter	npfa	PEV, Pressure switch	pev
NPFB, Threaded fitting	npfb	PEV-WD, Angled socket	pev*wd
NPV, Adapter	npfv	PFAN, Plastic tubing, approved for foodstuffs	pfan
NPQM, Push-in fitting	npqm	PKB, Spiral wrap for tubing	pkb
NPQP-D		PKS, Tubing support	pks
– Push-in connector	929	PLN, Plastic tubing	pln
– Push-in fitting	929	PM, Plastic-coated metal tube	n_070100
NPQP-H, Push-in bulkhead connector	929	PPL, Cylinder signal generator	ppl
NPQP-L		PPS, Spiral plastic tubing	pps
– Push-in L-connector	930	PQ, Pipe clamp	pq
– Push-in L-fitting	930	PQ-AL, Pipe	n_070100
NPQP-LQ, Push-in L-fitting	930	PQ-PA, Plastic pipe	pq
NPQP-P, Blanking plug	930	Proximity sensor for C-slot	
NPQP-T		– SME-10, Magnetic reed	747
– Push-in T-connector	931	– SME-10M, Magnetic reed	745
– Push-in T-fitting	931	Proximity sensor for T-slot	
NPQP-Y		– SME-8, Magnetic reed	734
– Push-in Y-connector	931	– SME-8M, Magnetic reed	732
– Push-in Y-fitting	931	– SMT-8M-A, Magneto-resistive	737
NSC, Isolating disc for creating pressure zones, to ISO 5599-1	568	PRS, Manifold block for Tiger Classic valve	607
NST		PRSB, Blanking plate for manifold block PRS, Tiger Classic valve	607
– Slot nut for spindle axis EGC-BS	328	PS1	
– Slot nut for spindle axis EGC-HD-BS	338	– Programming cable for motor controller CMMD-AS	449
– Slot nut for toothed belt axis EGC-HD-TB	359	– Programming cable for motor controller CMMF-AS	458
– Slot nut for toothed belt axis EGC-TB	350	– Programming cable for motor controller CMMS-AS	453
NTSD		– Programming cable for motor controller CMMS-ST	466
– Power supply for terminal CPX	717	PS1-ZK11, Programming cable	cmms-st
– Power supply socket	ntsd	PS1-SAC, Plug	ps1
NVF3, 5/2-way valve, to NAMUR	namur	PS1-ZC, Plug	ps1
NZV, Intermediate plate for connecting the valve terminal sizes 02 and 01, to ISO 15407-1	547	PU, Plastic tubing	pu
		PUN, Plastic tubing, standard O.D.	904, 907
		PUN-CM, Plastic tubing	pun-cm
		PUN-VO, Plastic tubing, flame-retardant	pun-v0
		PUN-DUO, DUO tubing, standard O.D.	906
		PUN-H, Plastic tubing, standard O.D., hydrolysis-resistant	905, 907
		PUN-H-DUO, DUO tubing, standard O.D., hydrolysis-resistant	906
		PUN-S, Spiral plastic tubing	pun-s
		PUN-S-DUO, Spiral plastic tubing, DUO tubing	pun-s
		PUN-SG, Spiral plastic tubing	pun-sg
		PV-3-1/8, Heavy-duty palm button valve, 3/2-way valve	n_v18
O			
O, Sealing ring	937		
OFSW, Special oil for MS series	891		
OGGB, Bernoulli gripper	oggb		
OH, Pressure indicator	oh		
OK, Sealing ring	938		
OK-S1, Sealing ring assortment	938		
OL, Sealing ring	937		

Type	Page/online
PWEA, Condensate drain	pwea
PZA, Counter	pza
PZV, Counter	pza
PZVT, Timer	pzvt
Q	
QH, Ball valve, manually actuated, with female thread	qh
QH-DR, Limit switch attachment	qh-dr
QH-QS, Ball valve, manually actuated, with push-in connector	qh
QHS-QS, Ball valve, manually actuated, with push-in connector and bulkhead fitting	qh
QM, Sleeve	qm
QMR, Reducing sleeve	qmr
QS	
– Push-in connector, Quick Star	917
– Push-in fitting, Quick Star	916
QS-B, Push-in fitting, standard	qs-b
QS-F, Push-in fitting, metal	qs-f
QS-V0, Push-in fitting, flame-retardant	qs-v0
QSF, Push-in fitting, Quick Star	918
QSK, Self-sealing, push-in fitting, standard	qsk
QSL	
– Push-in L-connector, Quick Star	921
– Push-in L-fitting, Quick Star	919
QSLF, Push-in L-fitting, Quick Star	921
QSLL, Push-in long L-fitting, Quick Star	920
QSLV, Push-in L-fitting, Quick Star	922
QSLV2, Multiple distributor, Quick Star	933
QSLV3, Multiple distributor, Quick Star	933
QSLV4, Multiple distributor, Quick Star	934
QSLV6, Multiple distributor, Quick Star	934
QSM	
– Push-in connector, Quick Star, mini	911
– Push-in fitting, Quick Star, mini	910
QSM-B, Push-in fitting, mini	qsm-b
QSMF, Push-in fitting, Quick Star, mini	911
QSMML	
– Push-in L-connector, Quick Star, mini	913
– Push-in L-fitting, Quick Star, mini	912
QSMMLL, Push-in long L-fitting, Quick Star, mini	912
QSMMLLV, Push-in long L-fitting, Quick Star, mini	913
QSMMLV, Push-in L-fitting, Quick Star, mini	913
QSMS, Push-in bulkhead connector, Quick Star, mini	911
QSMT	
– Push-in T-connector, Quick Star, mini	914
– Push-in T-fitting, Quick Star, mini	914
QSMTL, Push-in T-fitting, Quick Star, mini	914
QSMY, Push-in Y-connector, Quick Star, mini	915
QSO, Releasing tool, for tubing	qso
QSP, Cartridge, push-in cartridge	qsp
QSP10, Adapter	qsp10
QSQ, Multiple distributor, Quick Star	935
QSR, Rotary push-in fitting, standard	qsr
QSS, Push-in bulkhead connector, Quick Star	918
QST	
– Push-in T-connector, Quick Star	923
– Push-in T-fitting, Quick Star	923
QSTF, Push-in T-fitting, Quick Star	924
QSTL, Push-in T-fitting, Quick Star	924
QSW	
– Push-in connector, Quick Star	925
– Push-in fitting, Quick Star	925
QSY	
– Push-in Y-connector, Quick Star	926
– Push-in Y-fitting, Quick Star	926
QSYL, Push-in Y-fitting, Quick Star	927
QSYLV, Push-in Y-fitting, Quick Star	927
QSYTF, Multiple distributor	qsytf

Type	Page/online
R	
R	
– Roller lever valve, 3/2-way valve	r-3
– Roller lever valve, 5/2-way valve	r-5
R/O, Roller lever valve, 3/2-way valve	r/o-3
RFL, Reflex sensor	rfl
RML, Micro reflex sensor	rml
RO, Roller lever valve, 3/2-way valve	ro-3
ROS, Roller lever valve, 3/2-way valve	ros-3
RS	
– Roller lever valve, 3/2-way valve	rs-3
– Roller lever valve, 4/2-way valve	rs-4
RW, Swivel lever valve, 3/2-way valve	rw-3
RW/O, Swivel lever valve, 3/2-way valve	rw/o-3
RWN/O, Pneumatic limit valve, 3/2-way valve	rwn/o-3
S	
S-3-PK, Stem actuated micro valve, 3/2-way valve	s-3-pk
S-3, Micro switch	s-3
SBA-2N, Memory module	sba
SBN	
– Swivel mounting for round cylinder DSNU/ESNU	99
– Swivel mounting for standard cylinder to ISO 6432	85
SBOA, Cable	sboa
SBOA-M-SYSTAINER, Vision system	sbox
SBOC-M, Compact vision system, for standard lenses with C/CS mount connection	sbox
SBOC-Q, Compact vision system, for standard lenses with C mount connection	sbox
SBOI-Q, Compact vision system, with integrated lens	sbox
SBS, Inscription label	sbs
SCM, Bulkhead fitting	scm
SCN, Barbed fitting	n_070302f
SD, Back pressure end stop	sd-2
SD-4-WD, Angled socket	sd-4-wd
SD-SUB	
– Plug	sd-sub
– Plug socket	sd-sub
SDE1, Pressure sensor with display	762
SDE3, Pressure sensor with display	sde3
SDE5, Pressure sensor	767
SDK, Limit valve, 3/2-way valve	sdk
SDV, Limit stop signal generator, 3/2-way valve	sdv
SE, Quick exhaust valve	se
SEA	
– Plug	sea
– Plug socket for EB solenoid coil, to ISO 5599-1	567
SEA-M12	
– Plug for I-Port/IO-Link, valve terminal VTUG	660
– Plug for valve terminal MPA-L	669
SEC-ST, Motor controller	sec-st
Sensor bracket for opto-electronic sensors, SIEZ	787
SEU, Quick exhaust valve	seu
SF-EGC-1	
– Switch lug for linear drive DGC-HD with heavy-duty guide	175
– Switch lug for spindle axis EGC-BS	328
– Switch lug for spindle axis EGC-HD-BS	338
– Switch lug for toothed belt axis EGC-HD-TB	358
– Switch lug for toothed belt axis EGC-TB	348
SF-EGC-2	
– Switch lug for linear drive DGC-HD with heavy-duty guide	175
– Switch lug for spindle axis EGC-BS	328
– Switch lug for spindle axis EGC-HD-BS	338
– Switch lug for toothed belt axis EGC-HD-TB	358
– Switch lug for toothed belt axis EGC-TB	348
SFAB, Flow sensor	sfab
SFAM, Flow sensor	sfam
SFC-DC, Motor controller	sfc-dc
SFC-LACI, Motor controller	sfc-laci
SFE3, Flow sensor	sfe3
SFET, Flow sensor	sfet

Type	Page/online	Type	Page/online
SFEV, Flow indicator	sfev	SMB-FENG, Mounting kit for proximity sensors with guide units FENG	743
SFL, Air barrier, receiver/sender nozzle	sfl	SMBK	
SG		– Clip for toothed belt axis EGC-TB	350
– Rod clevis for compact cylinder to ISO 21287	115	– Clip for toothed belt axis ELGA-TB	380
– Rod clevis for electric cylinder DNCE	311, 318	SMBK-8, Cable clip, For T-slot	743
– Rod clevis for electric cylinder EPCO	302	SMBN-10, Mounting, For proximity sensor for C-slot	753
– Rod clevis for round cylinder DSNU/ESNU	99	SMBR	
– Rod clevis for short-stroke cylinder ADVC/AEVC	132	– Mounting kit, for proximity sensors for T-slot	743
– Rod clevis for standard cylinder DSBC to ISO 15552	42	– Mounting kit, for proximity sensors, for round cylinders DSNU/ESNU	100
– Rod clevis for standard cylinder DSBG to ISO 15552	51	– Mounting kit, For proximity sensor for C-slot	753
– Rod clevis for standard cylinder to ISO 15552	68	– Mounting kit for proximity sensor, for standard cylinder DSNU to ISO 6432	85
– Rod clevis for standard cylinder to ISO 6432	85	SMBR-8-8/100-S6, Mounting kit, corrosion protection, for proximity sensors for T-slot	743
SGA		SMBZ-8, mounting kit for proximity sensor SME/SMT-8	743
– Rod clevis for compact cylinder to ISO 21287	115	SME-10, Proximity sensor for C-slot, Magnetic reed	744, 747
– Rod clevis for electric cylinder DNCE	310, 318	SME-10M, Proximity sensor for C-slot, Magnetic reed	745
– Rod clevis for electric cylinder EPCO	302	SME-8, Proximity sensor for T-slot, Magnetic reed	730
– Rod clevis for round cylinder DSNU/ESNU	101	– Heat-resistant	734
– Rod clevis for short-stroke cylinder ADVC/AEVC	132	SME-8M, Proximity sensor for T-slot, Magnetic reed	732
– Rod clevis for standard cylinder DSBC to ISO 15552	42	SMEO	
– Rod clevis for standard cylinder DSBG to ISO 15552	51	– Proximity sensor, round design, for round cylinder DSNU/ESNU	100
– Rod clevis for standard cylinder to ISO 15552	68	– Proximity sensor, round design, for standard cylinder to ISO 6432	86
SGS		SMEO-1, Proximity sensor, block design	smeo-1
– Rod eye for compact cylinder to ISO 21287	114	SMEO-4U, Proximity sensor, round design	smeo-4
– Rod eye for electric cylinder DNCE	311, 318	SMEO-8E	
– Rod eye for electric cylinder EPCO	302	– Proximity sensor for T-slot, magnetic reed	smeo
– Rod eye for rotary/lifting module EHMB	405	– Proximity sensor for T-slot, magnetic reed, heat-resistant	smeo
– Rod eye for round cylinder DSNU/ESNU	99	SMH-AE, Evaluation unit	smh-ae
– Rod eye for short-stroke cylinder ADVC/AEVC	132	SMH-S1, Position sensor	smh-1
– Rod eye for standard cylinder DSBG to ISO 15552	42, 51	SML, Air barrier, sender nozzle	sml
– Rod eye for standard cylinder to ISO 6432	85	SMM-10, Position marker, For proximity sensor for C-slot	753
SIE-GD, Sensor socket	sie-gd	SMM-8, Position marker, For proximity sensor for T-slot	743
SIE-WD, Angled socket	sie-wd	SMPO-1, Proximity sensor, block design, pneumatic	smpo
SIE..., Proximity sensor, inductive	754	SMPO-8E, Proximity sensor, for T-slot, block design	smpo
SIEA, Proximity sensor, inductive, analogue output	siea	SMT-10, Proximity sensor for C-slot, Magneto-resistive	744
SIED		SMT-10M, Proximity sensor for C-slot, Magneto-resistive	749
– Proximity sensor, inductive, standard switching distance, for DC and AC voltage	sied	SMT-8, Proximity sensor for T-slot, Magneto-resistive	731
– Proximity sensor, inductive, standard switching distance, for DC and AC voltage, polyamide housing	sied	SMT-8M-A, Proximity sensor for T-slot, Magneto-resistive	737
SIEF, Proximity sensor, inductive, reduction factor 1 for all metals	sief	SMT-C1, Proximity sensor, block design, magneto-inductive	smt-c1
SIEF...-WA, Proximity sensor, inductive, reduction factor 1 for all metals, welding field immune	sief	SMTO	
SIEH		– Proximity sensor, round design, for round cylinder DSNU/ESNU	100
– Proximity sensor, inductive, increased switching distance	sieh	– Proximity sensor, round design, for standard cylinder to ISO 6432	86
– Proximity sensor, inductive, increased switching distance, stainless steel housing	sieh	SMTO-1, Proximity sensor, block design	smt-1
SIEN		SMTO-4U, Proximity sensor, round design	smt-4
– Proximity sensor, inductive, standard switching distance	755	SMTO-8E, Proximity sensor for T-slot, magneto-resistive	smt-8
– Proximity sensor, inductive, standard switching distance, polyamide housing	756	SMTSO-1, Proximity sensor, block design	smtso-1
SIES, Proximity sensor, inductive, special design	sies	SMTSO-8E, Proximity sensor for T-slot, magneto-resistive, welding field immune	smtso
SIES-8M, Proximity sensor, inductive for T-slot	759	SNC	
SIEZ		– Swivel flange for electric cylinder DNCE	310, 318
– Sensor bracket for inductive proximity sensor	758	– Swivel flange for short-stroke cylinder ADVC/AEVC	131
– Sensor bracket for opto-electronic sensors	787	– Swivel flange for standard cylinder DSBG to ISO 15552	41, 50
SIEZ-8M, Sensor bracket for proximity sensor	761	– Swivel flange for standard cylinder to ISO 15552	67
SIEZ-LB		SNCB	
– Inscription label	siez-lb	– Swivel flange for compact cylinder to ISO 21287	114
– Inscription label for inductive proximity sensor	758	– Swivel flange for electric cylinder DNCE	310, 318
SIEZ-LB for opto-electronic sensors, Inscription label	787	– Swivel flange for electric cylinder EPCO	302
SIM, Plug socket with cable	sim	– Swivel flange for short-stroke cylinder ADVC/AEVC	132
SK, Hose clip	sk	– Swivel flange for standard cylinder DSBG to ISO 15552	41, 50
SL-DSM, Sensor bracket for swivel module DSM-B	213	– Swivel flange for standard cylinder to ISO 15552	67
SLE, Linear drive unit, with recirculating ball bearing guide	sle	SNCB...-R3, Swivel flange for standard cylinder DSBF-C to ISO 15552	60
SLF, Mini slide, flat design	slf	SNCL	
SLG, Linear drive, flat design	slg	– Swivel flange for compact cylinder to ISO 21287	114
SLM, Linear drive, with guide	slm	– Swivel flange for electric cylinder DNCE	310, 318
SLS, Mini slide, slim design	sls	– Swivel flange for electric cylinder EPCO	302
SLT, Mini slide, compact design	slt	– Swivel flange for short-stroke cylinder ADVC/AEVC	132
SLTE, Mini slide, electric	slte	– Swivel flange for standard cylinder DSBG to ISO 15552	41, 50
SMAT-8E, Position transmitter for T-slot, magnetic	smat-8e	– Swivel flange for standard cylinder to ISO 15552	67
SMAT-8M, Position transmitter for T-slot, magnetic	smat-8m	SNC5	
SMB-8E, Mounting kit, for proximity sensors for T-slot	743	– Swivel flange for compact cylinder to ISO 21287	114
		– Swivel flange for electric cylinder DNCE	310, 318

Type	Page/online	Type	Page/online
– Swivel flange for electric cylinder EPCO	302	UOS, Silencer	uos
– Swivel flange for short-stroke cylinder ADVC/AEVC	132	V	
– Swivel flange for standard cylinder DSBG to ISO 15552	41, 50	V	
– Swivel flange for standard cylinder to ISO 15552	67	– Stem actuated valve, 3/2-way valve	v-3
SO-3-PK, Stem actuated micro valve, 3/2-way valve	so-3-pk	– Stem actuated valve, 5/2-way valve	v-5
SOE-LKS for opto-electronic sensors, Fibre-optic cutter	787	V-PK, Barbed fitting	n_070302f
SOE4, Fibre-optic unit	soe4	V/O, Stem actuated valve, 3/2-way valve	v/o
SOEC-RT, Colour sensor	soec	VABA, Pneumatic interface for terminal CPX	716
SOEG-, SOEL-, Opto-electronic sensors	771	VABB	
SOEZ, Fibre-optic cable	soez	– Blanking plate for valve position, valve terminal VTSA	638
SOEZ-HW, Mounting bracket for opto-electronic sensors	787	– Blanking plate for valve position, valve terminal VTUG	659
SOEZ-LLG for opto-electronic sensors, Fibre-optic cable, glass fibre	787	VABB-L1-10-W, Blanking plate for manifold rail for VUVG, sub-base valve M5/M7	588
SOEZ-LLK for opto-electronic sensors, Fibre-optic cable, polymer	787	VABB-L1-10S, Blanking plate for manifold rail for VUVG, in-line valve M5/M7	576
SOEZ-RFF for opto-electronic sensors, Reflector foil	787	VABB-L1-14, Blanking plate for manifold rail for VUVG, in-line valve G1/8	582
SOEZ-RFL for opto-electronic sensors, Reflector for laser light	787	VABB-L1-14 , Blanking plate for manifold rail, sub-base valve VUVG, G1/8	594
SOEZ-RFS for opto-electronic sensors, Reflector	787	VABD	
SOOC		– Blanking plug for pressure zone separation for manifold rail VABM-L1-14W	594
– Diffuse sensor	sooc	– Duct separation for valve terminal VTSA	639
– Fibre-optic unit	sooc	– Separator for valve terminal VTUG	659
SOOF, Fork light barrier	soof	VABE, Electrical interface for valve terminal VTSA	639
SOPA, Air gap sensor	sopa	VABE-S6, End plate for valve terminal VTSA	638
SPAB, Pressure sensor with display	spab	VABF	
SPBA, Pressure sensor for solenoid valve VSVA	spba	– 90° connection plate for valve terminal VTSA	642
SPC-AIF, Axis interface	spc-aif	– Flow control plate for valve terminal VTSA	638
SPC11, End-position controller	spc11	– Pressure regulator plate	539
SPC200, Axis controller	spc200	– Regulator plate for valve terminal VTSA	637
SPT, Pressure transmitter	spte	– Supply plate for valve terminal VTSA	639
SPTW, Pressure transmitter	sptw	– Vertical pressure shut-off plate for valve terminal VTSA	638
SPZ, Slide unit, twin piston	spz	– Vertical supply plate for valve terminal VTSA	638
SRAP, Sensor box, analogue	srp	VABF-L1, Supply plate for valve terminal VTUG	659
SRBF, Limit switch attachments	srbf	VABF-L1-10-P3A4-M5	
SRBP, Sensor box, binary	srbp	– Supply plate for manifold rail for VUVG, sub-base valve M5	588
STA, Stopper cylinder	sta	– Supply plate for manifold rail for VUVG, in-line valve M5	576
STAF, Stopper cylinder, with flange mounting	staf	VABF-L1-10-P3A4-M7	
SV		– Supply plate for manifold rail for VUVG, in-line valve M7	576
– Front panel valve, 3/2-way valve	sv-3	– Supply plate for manifold rail for VUVG, sub-base valve M7	588
– Front panel valve, 5/2-way valve	sv-5	VABF-L1-14-P3A4-G18	
SV/O, Front panel valve, 2x3/2-way valve	sv/o	– Supply plate for manifold rail for VUVG, in-line valve G1/8	582
SVE4, Evaluation unit	sve4	– Supply plate for manifold rail, sub-base valve VUVG, G1/8	594
SVG, Power supply units	svg	VABM-L1-10HW, Manifold rail for VUVG, sub-base valve M7	588
SVG-SEC, Power supply unit for motor controller CMMS-ST	466	VABM-L1-10S, Manifold rail for VUVG, in-line valve M5/M7	576
SVOS, Front panel valve, 3/2-way valve	svos	VABM-L1-10W, Manifold rail for VUVG, sub-base valve M5	588
SVS		VABM-L1-14S, Manifold rail for VUVG, in-line valve G1/8	582
– Front panel valve, 3/2-way valve	svs	VABM-L1-14W, Manifold rail for sub-base valve VUVG, G1/8	594
– Front panel valve, 4/2-way valve	svs	VABS, Individual sub-base for valve terminal VTSA	641
T		VABV, Manifold sub-base for valve terminal VTSA	639
T-5/3-1/4, Pushbutton valve, 5/3-way valve	n_v14	VAD, Vacuum generator	vad
T-PK, Barbed fitting	n_070302f	VAD-M, Vacuum generator	vad-m
TAA, Pulse oscillator	taa	VAD-M-I, Vacuum generator	vad-m
TAB, Pulse oscillator	tab	VADM, Vacuum generator	vadm
TCN, Barbed fitting	n_070302f	VADMI, Vacuum generator	vadmi
TH		VAEM, AS-interface module for valve terminal VTSA	639
– Finger lever valve, 3/2-way valve	th-3	VAEM-L1-S-M1, Sub-D, electrical interface for valve terminal VTUG	659
– Finger lever valve, 5/2-way valve	th-5	VAEM-L1-S-M3 , Flat cable plug, electrical interface for valve terminal VTUG	659
TH/O-3-PK-3, Finger lever valve, 3/2-way valve	n_vpk	VAEM-L1-S-PT, I-Port interface, electrical interface for valve terminal VTUG	659
THO, Finger lever valve 3/2-way valve	th-3	VAF, Vacuum filter	vaf
Tiger Classic, Solenoid valve	596	VAK, Vacuum generator	vak
TJK, T-fitting	tjk	VAL, Height compensator	val
TK, Ring piece	tk	VAM	
U		– Vacuum gauge	vam
U, Silencer	994	– Vacuum gauge to EN 837-1	vam
UC, Silencer	uc	– Vacuum gauge to EN 837-1, with red-green range	vam
UO, Silencer	uo	VAME	
UOM, Silencer	uom	– H-rail mounting for valve terminal VTUG	659
UOMS		– Mounting bracket for valve terminal VTSA	642
– Silencer	uoms	VAME-T-M4, H-rail mounting for VUVG	595
– Silencer extension	uoms	VAPB, Ball valve, 2-way ball valve	vapb
		VAS, Suction cup	vas

Type	Page/online	Type	Page/online
VASB, Suction cup	vasb	VOVG	
VAVE-L1, E-box for valves VUVG	595	– 3/2-way valve, in-line valve	vovg
VBNF, Non-return valve	vbnf	– 3/2-way valve, semi in-line valve	vovg
VBOH, Hand slide valve	vboh	– 3/2-way valve, sub-base valve	vovg
VBQF, Quick exhaust valve	vbqf	– 5/2-way valve, semi in-line valve	vovg
VFFK, Flow control/silencer	615	– 5/2-way valve, sub-base valve	vovg
VFOC, One-way flow control valve	vfof	– Solenoid valve	vovg
VFOF		VPE, Pressure switch, for vacuum	vpe
– One-way flow control valve, flat	613	VPPE, Proportional pressure regulator, 3/2-way valve	vppe
– One-way flow control valve, function combination	614	VPPM, Proportional pressure regulator, 3/2-way valve	vppm
VHEM-L, Finger lever valve	vhem-l	VPWP	
VHEM-P, Pushbutton valve	vhem-p	– Proportional directional control valve	vpwp
VHER, Hand lever valve	vher	– Proportional pressure regulator, 5/3-way valve	vpwp
VK, Amplifier module	os	VS	
VL		– Stem actuated valve, 3/2-way valve	vs-3
– 5/2-way valve, midi pneumatic	n_md	– Stem actuated valve, 4/2-way valve	vs-4
– 5/2-way valve, pneumatic valve, to ISO 5599-1	iso 5599-1	VSCS, Pilot valve for valves, to ISO 15407-1	548
– 5/3-way valve, midi pneumatic	n_md	VSCS-B-M32...C1, Standard valve with square plug, type C	iso 15218
– 5/3-way valve, pneumatic valve, to ISO 5599-1	iso 5599-1	VSCS-B-M32...R3, Standard valve with round plug	iso 15218
– Pneumatic valve 5/2-way for mounting frame 2N	m5 compact	VSNB	
VL-B		– 3/2-way valve, to NAMUR	namur
– 5/2-way valve, Tiger 2000	tiger 2000	– 5/2-way valve, to NAMUR	namur
– 5/3-way valve, Tiger 2000	tiger 2000	VSPA	
VL/O, Pneumatic valve 3/2-way for mounting frame 2N	m5 compact	– 2x 3/2-way valve, to ISO 15407-1	542
VLG, Pulse oscillator	vlg	– 5/2-way valve, bistable, to ISO 15407-1	543
VLHE, Pneumatic valve	vlhe	– 5/2-way valve, monostable, to ISO 15407-1	542
VLO, OR gate	os	– 5/3-way valve, to ISO 15407-1	543
V LX, 2/2-way valve	vlx	VSVA	
V MEM		– 2x 3/2-way valve, to ISO 15407-1	535
– Stem actuated valve, 3/2-way valve	vmem	– 2x 3/2-way valve, to ISO 5599-1	549
– Stem actuated valve, 5/2-way valve	vmem	– 5/2-way valve, double solenoid, to ISO 15407-1	536
VMPA, Sub-base valve for valve terminal MPA-L	670	– 5/2-way valve, single solenoid, to ISO 15407-1	535
VMPA-E, Exhaust plate for valve terminal MPA-L	675	– 5/2-way valve, to ISO 5599-1	549
VMPA-FB-EPLM, Pneumatic interface for terminal CPX-P	986	– 5/3-way valve, to ISO 15407-1	536
VMPA-HB		– 5/3-way valve, to ISO 5599-1	549
– Cover cap for manual override for valves VUVG, valve terminal VTUG	659	– Double solenoid valve, to ISO 5599-1	556
– Cover for manual override for valve terminal MPA-L	671	– Solenoid valve for valve terminal VTSA	633
VMPA-KMS, Connecting cable	vmpa-kms	VSVA-T1, Standard valve for valve terminal VTSA	vsva
VMPA1		VT	
– Solenoid valve, 2x2/2-way valve	vmpa1	– Hollow bolt	vt
– Solenoid valve, 2x3/2-way valve	vmpa1	– Hollow bolt for manifold block PRS, Tiger Classic valve	607
– Solenoid valve, 3/2-way valve	vmpa1	– Hollow bolt for manifold rail PAL, Tiger Classic valve	607
– Solenoid valve, 5/2-way valve	vmpa1	VTIA, Valve terminal	vtia
– Solenoid valve, 5/3-way valve	vmpa1	VTOC, Valve terminal	vtoc
VMPA1-ST, Inscription label holder	vmpa1-st	VTSA, Valve terminal VTSA	622
VMPA1-B8, Regulator plate for valve terminal MPA-L	671	VTSA-F, Valve terminal	vtsa-f
VMPA1-RP, Blanking plate for vacant position of valve terminal MPA-L	676	VTUB, Valve terminal	vtub
VMPAL-AP, Sub-base for valve terminal MPA-L	673	VTUB-12, Valve terminal	vtub-12
VMPAL-BD, Mounting bracket for valve terminal MPA-L	676	VUVB	
VMPAL-EPL, Left-hand end plate for valve terminal MPA-L	669	– Solenoid valve, 3/2-way valve	vuvb
VMPAL-EPR, Right-hand end plate for valve terminal MPA-L	671	– Solenoid valve, 4/2-way valve	vuvb
VMPAL-EVAP, Electrical interlinking module for valve terminal MPA-L	675	VUVG, Solenoid valve	570
VMPAL-KM, Connecting cable for multi-pin plug connection for valve terminal MPA-L	669	VUVG-B	
VMPAL-SP, Power supply module for valve terminal MPA-L	675	– Solenoid valve, 2x3/2-way valve	570
VMPAL-ST, Inscription label holder for valve terminal MPA-L	672	– Solenoid valve, 5/2-way valve	570
VMPAL-ZA, Tie rod for valve terminal MPA-L	672	– Solenoid valve, 5/3-way valve	570
VN		VUVG-B-T1	
– Vacuum generator cartridge	vn	– Solenoid valve, 2x3/2-way valve for valve terminal VTUG	643
– Vacuum generator, electro-pneumatic	vn	– Solenoid valve, 5/2-way valve for valve terminal VTUG	643
– Vacuum generator, pneumatic	vn	– Solenoid valve, 5/3-way valve for valve terminal VTUG	643
VO, Stem actuated valve, 3/2-way valve	vo-3	VUVG-L	
VOFA		– Solenoid valve, 2x3/2-way valve	570
– Control block	vofa	– Solenoid valve, 5/2-way valve	570
– Control block for valve terminal VTSA	642	– Solenoid valve, 5/3-way valve	570
VOFC		VUVG-S	
– 3/2-way valve	vofc	– Solenoid valve, 2x3/2-way valve	570
– 5/2-way valve	vofc	– Solenoid valve, 5/2-way valve	570
VOFD, 3/2-way valve	vofd	– Solenoid valve, 5/3-way valve	570
VOS, Stem actuated valve, 3/2-way valve	vos	VUVG-S-T1	

Type	Page/online	Type	Page/online
- Solenoid valve, 2x3/2-way valve for valve terminal VTUG	643	- Centring pin for linear drive DGC	153
- Solenoid valve, 5/2-way valve for valve terminal VTUG	643	- Centring pin for linear drive DGC-HD with heavy-duty guide	175
- Solenoid valve, 5/3-way valve for valve terminal VTUG	643	- Centring pin for spindle axis EGC-HD-BS	338
VUWG		- Centring pin for toothed belt axis EGC-BS	328
- 2x3/2-way valve, pneumatic valve	vuwg	- Centring pin for toothed belt axis EGC-HD-TB	358
- 5/2-way valve, pneumatic valve	vuwg	- Centring pin for toothed belt axis EGC-TB	348
- 5/3-way valve, pneumatic valve	vuwg	ZBV , Connector sleeve for mini slide DGSL	257
VZ , Time delay valve for mounting frame 2N	m5 compact	ZDS , Disconnecting pliers, for tubing	zds
VZA , Time delay valve	vza	ZK	
VZB , Time delay valve	vza	- AND module	zk
VZBA		- Logic component, AND function	zk
- Ball valve actuator unit	vzba	ZMS , Connecting pliers, for tubing	zms
- Ball valve, 2-way ball valve	vzba	ZNCF	
- Ball valve, 3-way ball valve	vzba	- Trunnion flange for compact cylinder to ISO 21287	114
VZBC		- Trunnion flange for short-stroke cylinder ADVC/AEVC	131
- Ball valve actuator unit	vzbc	- Trunnion flange for standard cylinder DSBG to ISO 15552	41, 50
- Ball valve, corrosion-resistant	vzbc	- Trunnion flange for standard cylinder to ISO 15552	67
VZO , Time delay valve for mounting frame 2N	m5 compact	ZNCF	
VZOA , Time delay valve	vza	- Trunnion flange for electric cylinder DNCE	310, 318
VZOB , Time delay valve	vza	- Trunnion flange for electric cylinder EPCO	302
VZPR , Ball valve actuator unit	vzpr	ZNCM , Trunnion mounting kit for electric cylinder DNCE	311
VZQA , Proportional media valve	vzqa	ZR , Pipe cutter	zr
VZS , Air reservoir	vzs	ZRS , Pipe and tubing cutter	zrs
VZWD , 2/2-way valve	vzwd	ZSB , Control block for two-hand start	zsb
VZWE , Reverse jet pulse valve, 2/2-way valve	vzwe		
VZWF , 2/2-way valve, force pilot operated	vzwf		
VZWM			
- 2/2-way valve	vzwm-l		
- 2/2-Wegeventil	vzwm-l		
VZWP , 2/2-way valve, servo controlled	vzwp		
VZXF , Angle seat valve	vzxf		
W			
W , Hand slide valve, 3/2-way valve	w-3		
WA , Condensate drain	wa		
WBN			
- Swivel mounting for round cylinder DSNU/ESNU	99		
- Swivel mounting for standard cylinder to ISO 6432	85		
WSM			
- Mounting kit, For proximity sensor for swivel module DSM	753		
- Mounting kit for proximity sensor, for swivel module DSM	198		
Y			
Y-PK , Barbed fitting	n_070302f		
YD , Hydraulic cushioning cylinder	yd		
YSR-C , Shock absorber	ysr-c		
YSRW			
- Shock absorber	ysrw		
- Shock absorber for linear drive DGC	153		
- Shock absorber for linear drive DGC-HD with heavy-duty guide	175		
- Shock absorber for toothed belt axis EGC-HD-TB	358		
- Shock absorber for toothed belt axis EGC-TB	348		
YSRWJ , Shock absorber	ysrwj		
YZL , Hydraulic cushioning cylinder	yzl		
Z			
ZBH			
- Centring sleeve for guided drive DFM	275		
- Centring sleeve for linear drive DGC	153		
- Centring sleeve for linear drive DGC-HD with heavy-duty guide	175		
- Centring sleeve for mini slide DGSL	256		
- Centring sleeve for rotary module ERMB	391		
- Centring sleeve for spindle axis EGC-HD-BS	338		
- Centring sleeve for toothed belt axis EGC-BS	328		
- Centring sleeve for toothed belt axis EGC-HD-TB	358		
- Centring sleeve for toothed belt axis EGC-TB	348		
- Centring sleeve for twin-piston semi-rotary drive DRQD	233		
ZBS			

Designation	Page/online	Designation	Page/online
A			
Accessories for drives, see Clevis foot		– EAMM-A for toothed belt axis EGC-TB	348
Activated carbon filter		– EAMM-A for toothed belt axis ELGA-TB	379
– LFX, D series, metal	lfx	– EAMM-A for toothed belt axis ELGR	387
– MS12-LFX, MS series	ms12-lfx	Axis controller	
– MS4/MS6-LFX, MS series	ms4-lfx	– CPX-CMAX	cpx-cmax
– MS9-LFX, MS series	ms9-lfx	– SPC200	spc200
Adapter		Axis interface, SPC-AIF	spc-aif
– AD	ad	B	
– AD for compact cylinder to ISO 21287	115	Back pressure end stop, SD	sd-2
– AD for standard cylinder to ISO 15552	68	Ball valve	
– CAPC-F1-E-M12 for valve terminal VTUG with fieldbus node CTEU	660	– VAPB, 2-way ball valve	vapb
– DSM-FF for mounting kit WSM, for swivel module DSM	198	– VZBA, 2-way ball valve	vzba
– DSM-FF for stop kit KSM, for swivel module DSM	198	– VZBA, 3-way ball valve	vzba
– FB-TA, T-shape	fb-ta	– VZBC, corrosion-resistant	vzbc
– NPFA	npfa	Ball valve actuator unit	
– NPFV	npfv	– VZBA	vzba
– QSP10	qsp10	– VZBC	vzbc
Adapter connector, MKA, for protective conduits	mka	– VZPR	vzpr
Adapter kit, EAHA for electric cylinder EPCO	302	Ball valve, manually actuated	
Adapter plate kit, EHAM for rotary/lifting module EHMB	405	– QH-QS, with push-in connector	qh
Adding counter, CCES	cces	– QH, with female thread	qh
Addressing cable, KASI-ADR	kasi-adr	– QHS-QS, with push-in connector and bulkhead fitting	qh
Adsorption dryer, PDAD	pdad	Barbed fitting	
Air barrier		– CN	n_070302f
– SFL, receiver/sender nozzle	sfl	– CRCN, stainless steel	n_070302f
– SML, sender nozzle	sml	– FCN	n_070302f
Air consumption	1044	– L-PK	n_070302f
Air cushion plate, ATBT	atbt	– LCN	n_070302f
Air dryer, see Adsorption dryer		– LCNH	n_070302f
Air gap sensor, SOPA	sopa	– N	n_070302f
Air nozzle, LPZ	lpz	– RTU	n_070302f
Air reservoir		– SCN	n_070302f
– CRVZS	993	– T-PK	n_070302f
– VZS	vzs	– TCN	n_070302f
Amplifier module, VK	os	– V-PK	n_070302f
AND module, ZK	zk	– Y-PK	n_070302f
Angle compensation, ESWA	eswa	Basic valve LC	
Angle gripper		– Pneumatic valve	lc
– DHWS	492	– Solenoid valve	lc
– HGWC	hgwc	Mounting kit, SMBZ-8, for proximity sensors for T-slot	743
– HGWM	hgwm	Mounting kit	
Angle seat valve, VZXF	vzxf	– CRSMB-8, corrosion resistance, for proximity sensors for T-slot	743
Angled socket		– SMB-8-FENG, for proximity sensors for guide units FENG	743
– MPPE-3-B	mppe-3-b	– SMB-8E, for proximity sensors for T-slot	743
– PEV-WD	pev*wd	– SMBR for proximity sensors, for round cylinders DSNU/ESNU	100
– SD-4-WD	sd-4-wd	Bellows actuator	
– SIE-WD	sie-wd	– EB, bellows	eb
Approvals	1047	– EBS, rolling bellows	ebs
AS-Interface® components, AS-i	as-i	Bellows gripper, DHEB	dheb
AS-i module, CESA	cesa	Bernoulli gripper, OGGB	oggb
AS-interface	as-interface	Blanking plate	
AS-interface module, VAEM for valve terminal VTSA	639	– PRSB for manifold block PRS, Tiger Classic valve	607
Assemblies	1007	– VABB-L1-10 S for manifold rail for VUVG, in-line valve M5/M7	576
ATEX 94/9/EC	1045	– VABB-L1-10-W for manifold rail for VUVG, sub-base valve M5/M7	588
Attachment for H-rail mounting		– VABB-L1-14 for manifold rail for VUVG, in-line valve G1/8	582
– CPX-CPA-BG-NRH for terminal CPX	717	– VABB-L1-14 for manifold rail, sub-base valve VUVG, G1/8	594
– CPX-CPA-BG-NRH for terminal CPX-P	987	Blanking plate for vacant position	
Attachment for wall mounting		– NDV-VDMA for standard valves, to ISO 15407-1	547
– CPX-BG-RW for terminal CPX	717	– VABB for valve terminal VTSA	638
– CPX-BG-RW for terminal CPX-P	987	– VABB for valve terminal VTUG	659
Axial kit		– VMPA1-RP for valve terminal MPA-L	676
– EAMM-A for electric cylinder DNCE	322	Blanking plug	
– EAMM-A for electric cylinder ESBF	312	– B	b-1
– EAMM-A for mini slide EGSL	367	– NPQP-P	930
– EAMM-A for rotary/lifting module EHMB	400	Blanking screw, DAMD for standard cylinder DSBF to ISO 15552	60
– EAMM-A for spindle axis EGC-BS	329	Branching module	
– EAMM-A for spindle axis EGC-HD-BS	339	– FRM, D series, metal	frm
– EAMM-A for toothed belt axis EGC-HD-TB	358	– MS-FRM, MS series	882

Designation	Page/online	Designation	Page/online
Buckling load graph	1043	– LBG for standard cylinder DSBG to ISO 15552	41, 50
Bulkhead fitting, SCM	scm	– LBG for standard cylinder to ISO 15552	67
Bus connection		– LBG used with rod eye SGS for short-stroke cylinder ADVC/AEVC	132
– FBA-1	fba-1	– LBG used with swivel flange SNCS for short-stroke cylinder ADVC/AEVC	132
– FBA-2	fba-2	– LBN	lbn
– FBSD-KL	fbsd-kl	– LBN for compact cylinder to ISO 21287	114
Bus nodes, CPX-FB for terminal CPX-P	984	– LBN for electric cylinder EPCO	302
		– LBN for round cylinder DSNU/ESNU	99
		– LBN for standard cylinder to ISO 6432	85
C		– LN	ln
Cable, SBOA	sboa	– LNG	lng
Cable clip, SMBK-8, For T-slot	743	– LNG for electric cylinder DNCE	310, 318
Cable distributor, ASI-KVT	asi-kvt	– LNG for short-stroke cylinder ADVC/AEVC	132
Cable socket		– LNG for standard cylinder DSBG to ISO 15552	41, 50
– ASI-SD	asi-sd	– LNG for standard cylinder to ISO 15552	67
– NEFU	nefu	– LSN for electric cylinder DNCE	310, 318
Cam		– LSN for short-stroke cylinder ADVC/AEVC	132
– EAPS for rotary/lifting module EHMB	405	– LSN for standard cylinder DSBG to ISO 15552	41, 50
– EAPS-...-CK, for rotary module ERMB	391	– LSN for standard cylinder to ISO 15552	68
Canilever axis		– LSNG	lsng
– DGEA-ZR with recirculating ball bearing guide	dgea	– LSNG for electric cylinder DNCE	310, 318
– EGSA	egsa	– LSNG for short-stroke cylinder ADVC/AEVC	132
Cartridge, QSP, push-in cartridge	qsp	– LSNG for standard cylinder DSBG to ISO 15552	41, 50
Cartridge cylinder, EGZ	egz	– LSNG for standard cylinder to ISO 15552	67
Cartridge solutions	1011	– LSNG for electric cylinder DNCE	310, 318
Cassette valve		– LSNG for short-stroke cylinder ADVC/AEVC	132
– Pneumatic valve	cm	– LSNG for standard cylinder DSBG to ISO 15552	41, 50
– Solenoid valve	cm	– LSNG for standard cylinder to ISO 15552	67
CE marking	1047	Clip	
Centring pin		– SMBK for toothed belt axis EGC-TB	350
– ZBS	zbs	– SMBK for toothed belt axis ELGA-TB	380
– ZBS for linear drive DGC	153	Colour sensor, SOEC-RT	soec
– ZBS for linear drive DGC-HD with heavy-duty guide	175	Compact cylinder	
– ZBS for spindle axis EGC-HD-BS	338	– ADN-EL	adn-el
– ZBS for toothed belt axis EGC-BS	328	– ADNGF	adngf
– ZBS for toothed belt axis EGC-HD-TB	358	– ADNP	adnp
– ZBS for toothed belt axis EGC-TB	348	– ADVU, double-acting	advu
Centring sleeve		– ADVUL, double-acting	advul
– ZBH	zbh	– ADVUL, non-rotating	advul
– ZBH for guided drive DFM	275	– AEVU, single-acting	aevu
– ZBH for linear drive DGC	153	– CDC	cdc
– ZBH for linear drive DGC-HD with heavy-duty guide	175	– CDC, double-acting, Clean Design	cdc
– ZBH for mini slide DGSL	256	– ADN-KP, double-acting, standard hole pattern with clamping unit	109
– ZBH for rotary module ERMB	391	Compact cylinder to ISO 21287	
– ZBH for spindle axis EGC-HD-BS	338	– ADN, double-acting	104
– ZBH for toothed belt axis EGC-BS	328	– AEN, single-acting	104
– ZBH for toothed belt axis EGC-HD-TB	358	Compact cylinder to ISO 21287, with polymer end caps, ADNP, double-acting	104
– ZBH for toothed belt axis EGC-TB	348	Compact Performance, Solenoid valve CPE	cpe
– ZBH for twin-piston semi-rotary drive DRQD	233	Compact vision system	
Checkbox		– SBOC-M, for standard lenses with C/CS mount connection	sbox
– CHB	chb	– SBOC-Q, for standard lenses with C mount connection	sbox
– CHB-C, Compact	chb-c	– SBOI-Q, with integrated lens	sbox
Clamping cartridge, KP	kp	Compensating component, EADC for electric cylinder DNCE	319
Clamping module, EV	ev	Components, see AS-Interface® components	
Clamping unit		Compressed air consumption analysis	1026
– DADL-EL for semi-rotary drive DRRD	188	Compressed air generation, Energy analysis	1024
– KEC	kec	Compressed air piping, see Pipe; Plastic pipe; Plastic-coated metal tube	
– KEC-S	kec	Compressed air preparation	1033
– KPE	kpe	Compressed air quality analysis	1028
Clean room suitability	1048	Condensate drain	
Clevis foot		– PWEA	pwea
– CRLBN, stainless steel	crlbn	– WA	wa
– CRLNG for standard cylinder DSBF-C to ISO 15552	60	Connecting cable	
– CRLNG, stainless steel	crlng	– FEC-KBG	fec-kgb
– CRSBS, stainless steel	crsbs	– KEA	kea
– LBG	lbg	– KM12	n_km12_km8
– LBG for compact cylinder to ISO 21287	114	– KM12 for EB solenoid coil, to ISO 5599-1	567
– LBG for electric cylinder DNCE	310, 318	– KM12-DUO-M8 for terminal CPX	715
– LBG for electric cylinder EPCO	302	– KM12-DUO-M8 for terminal CPX-P	986
– LBG for round cylinder DSNU/ESNU	101		

Designation	Page/online	Designation	Page/online
– KM12-M12 for terminal CPX	715	– CECX-C1	cecx-x-c1
– KM12-M12 for terminal CPX-P	986	– CECX-M1	cecx-x-m1
– KM8	n_km12_km8	– CMXR-C1	cmxr-c1
– KM8-M8 for terminal CPX	715	– CMXR-C2	cmxr-c2
– KM8-M8 for terminal CPX-P	986	– FED-CEC	fed-cec
– KMC for N1 solenoid coil, to ISO 5599-1	567	– FED-CECCAN	fed-ceccan
– KMF for F solenoid coil	607	Countbox, CHB-CB	chb-cb
– KMP3	kmp	Counter	
– KMP4	kmp	– PZA	pza
– KMP6	kmp	– PZV	pza
– KMP6 for multi-pin plug connection, valve terminal VTUG	660	Coupling	
– KMPYE	kmpye	– EAMC	eamc
– KRP	krp	– EAMD	eamd
– KSPC-AIF	kspc	Coupling piece	
– KSPC-SECST	kspc	– KSG	ksg
– KV-M12	kv-m12	– KSG for compact cylinder to ISO 21287	115
– KV-M12 for terminal CPX	715	– KSG for electric cylinder EPCO	302
– KVI	kvi	– KSG for round cylinder DSNU/ESNU	99
– KVI-CP for terminal CPX	714	– KSG for short-stroke cylinder ADVC/AEVC	132
– KVIA	kvia	– KSG for standard cylinder DSBC to ISO 15552	42
– MHJ9-KMH	mhj9-kmh	– KSG for standard cylinder DSBG to ISO 15552	51
– NEBC	nebc	– KSG for standard cylinder to ISO 15552	68
– NEBC for motor controller CMMO-ST	462	– KSG for standard cylinder to ISO 6432	85
– NEBC-M9W5 for terminal CPX	715	– KSZ	ksz
– NEBP	nebp	– KSZ for compact cylinder to ISO 21287	115
– NEBS	nebs	– KSZ for electric cylinder DNCE	311, 318
– NEBU	949	– KSZ for round cylinder DSNU/ESNU	99
– NEBU for solenoid valve VSVA, to ISO 15407-1	548	– KSZ for standard cylinder to ISO 6432	85
– NEBV	nebv	Cover	
– NEBV-S1	nebv	– AK-8KL for terminal CPX	715
– NEBV-S1G25-K for multi-pin plug connection, valve terminal VTUG	660	– AK-8KL for terminal CPX-P	986
– NEBV-S1G44-K for multi-pin plug connection, valve terminal VTUG	660	– DADS for mini slide DGSL	257
– NEBV-S1W37 for multi-pin plug connection, valve terminal VTSA	640	– EASC for mini slide EGSL	367
– VMPA-KMS	vmpa-kms	– EASC for rotary/lifting module EHMB	405
– VMPAL-KM for multi-pin plug connection, valve terminal MAP-L	669	– EASC...F for mini slide EGSL	367
Connecting cables, see Plug socket with cable, flat cable, connecting cable, cable, addressing cable, control cable, programming cable		– MS-SV-MH for MS series	891
Connecting plate, MS-AG for MS series	889	– MS-SV-MK for MS series	891
Connecting pliers, ZMS, for tubing	zms	Cover cap	
Connecting shaft, KSK	ksk	– AKM for swivel module DSM-B	215
Connection block		– ISK	isk
– CPX-AB for terminal CPX	715	– MS-END for MS series	889
– CPX-AB for terminal CPX-P	985	Cover cap for manual override, VMPA-HB for valves VUVG, valve terminal VTUG	659
– NEFC for motor controller CMMO-ST	462	Cover for manual override, VMPA-HB for valve terminal MPA-L	671
Connection plate, 90°, VABF for valve terminal VTSA	642	CP interface, CPX-CP for terminal CPX	714
Connector sleeve, ZBV for mini slide DGSL	257	CPX terminal	677
Control block		CPX-P terminal	968
– CPX-CEC	cpx-cec	Cushioning kit, DSM-P-B for swivel module DSM-B	213
– CPX-CEC, For terminal CPX	cpx-cec	Cushioning mount, DSM...-B for swivel module DSM-B	213
– CPX-CEC for terminal CPX	712	Cylinder	
– CPX-CMXX, For terminal CPX	cpx-cmxx	– DNCKE-S, with clamping unit, safety component	dncke-s
– CPX-FEC for terminal CPX	712	– DNCKE, with clamping unit	dncke
– VOFA	vofa	Cylinder signal generator, PPL	ppl
– VOFA for valve terminal VTSA	642	Cylinder/valve combination, DNC-V, standard cylinder	dnc-v
Control block for two-hand start, ZSB	zsb	D	
Control cabinets	1001, 1003, 1004	Description	documentation
Control cabinets for controllers	1004	Design awards	1048
Control cabinets for handling systems	1004	Diagnostic module, GFDM, software	gfdm
Control cable		Differential pressure regulator	
– KES	kes	– LRL	lrl
– KES-MC for motor unit MTR-DCI	437	– LRL	lrl
– NEBC for motor controller CMMO-AS	449	Differential pressure switch, PEN	pen
– NEBC for motor controller CMMO-ST	462	Diffuse reflection sensor, SOOC	sooc
– NEBC for motor controller CMMP-AS	458	Disconnecting pliers, ZDS, for tubing	zds
– NEBC for motor controller CMMS-AS	453	Displacement encoder	
– NEBC for motor controller CMMS-ST	466	– MLO-POT-LWG	mlo
Control system, CMCA	cmca	– MLO-POT-TLF	mlo
Controller		– MME-MTS-TLF	mme
– CECX-X	cecx	Display and control unit for sensors, see Signal converter	

Designation	Page/online	Designation	Page/online
Distributor, LTV	ltv	End clamp, LTE	lte
Distributor block		End plate	
– FR	fr	– CPX-EP for terminal CPX	716
– FRZ, for D series, metal	frz	– CPX-EP for terminal CPX-P	986
– MS4/MS6-FRM-FRZ, MS series	ms4-frz	– VABE-S6 for valve terminal VTSA	638
Double nipple		– VMPAL-EPL, left-hand, for valve terminal MPA-L	669
– E	e-1	– VMPAL-EPR, right-hand, for valve terminal MPA-L	671
– ESK	esk	End plate kit	
Double pilot valve 5/2-way		– NEV-ISO for standard valves, to ISO 5599-1	568
– J for mounting frame 2N	m5 compact	– NEV-VDMA for standard valves, to ISO 15407-1	547
– JD for mounting frame 2N	m5 compact	End-position controller	
Drive accessories, see Adapter; Central mounting; Centring pin; Centring sleeve; Clevis foot;		– CMFL	cmfl
trunnion support; slot nut; centring pin; centring sleeve; linear guide; clamping cartridge;		– CPX-CMPX for Soft Stop	cpx-cmpx
clamping unit; Coupling piece; Hex nut; Right-angle clevis foot; Rod clevis; Rod eye; Self-aligning		– SPC11	spc11
rod coupler; Slot cover; Slot nut; Threaded pin; Trunnion support		Energy analysis for compressed air generation	1024
Drive shaft, EAMB for toothed belt axis EGC-TB	349	Energy Saving Services	1024
Duct separation, VABD for valve terminal VTSA	639	Ethernet connection, FBS-RJ45 for terminal CPX	712
DUO tubing, standard O.D.		Evaluation unit, SMH-AE	smh-ae
– PUN-DUO	906	Exhaust air flow control valve, GRE	gru
– PUN-H-DUO, hydrolysis-resistant	906	Exhaust plate, VMPAL-E for valve terminal MPA-L	675
E		Explosion protection directive 94/9/EC	1045
E-box, VAVE-L1 for valves VUVG	595	F	
Earthing component, CPX-EPFE-EV for terminal CPX	712	F solenoid coil	
EC directives	1047	– MSF for standard valves, to ISO 5599-1	569
EduTrainer®	edutrain	– MSFG for Tiger Classic valve	607
Elbow, G	g-m5	– MSPW for Tiger Classic valve	607
Elbow fitting, LJK	ljk	Factory automation	1001
Electric cylinder, DNCE-LAS	dnce-las	Fast-switching valve, MH2, MH3, MH4	mh2
Electric cylinder with piston rod		Feed separator	
– DNCE	314	– HPV	hvp
– EPCC	297	– HPVS	hpvs
Electric cylinder with spindle drive, ESBF	306	Female hose connector	
Electric limit switch		– C-P	n_cnp
– EL, with toggle lever	el	– N-MS	n_cnp
– ER, with roller lever	er	– N-P	n_cnp
Electric slide		FHPP gateway, CPX-CM-HPP for terminal CPX	714
– EGSK	egsk	Fibre-optic cable, SOEZ	soez
– EGSP	egsp	Fibre-optic cable, glass fibre, SOEZ-LLG for opto-electronic sensors	787
Electrical interface		Fibre-optic cable, polymer, SOEZ-LLK for opto-electronic sensors	787
– CECX-C-2S1	cecx	Fibre-optic cutter, SOE-LKS for opto-electronic sensors	787
– CPX-CTEL	cpx-ctel	Fibre-optic unit	
– VABE for valve terminal VTSA	639	– SOE4	soe4
– VAEM-L1-S-M1, Sub-D for valve terminal VTUG	659	– SOOC	sooc
– VAEM-L1-S-M3, flat cable plug for valve terminal VTUG	659	Fieldbus adapter	
– VAEM-L1-S-PT, I-Port interface, electrical interface for valve terminal VTUG	659	– FBA-CO	fba-co
Electrical interlinking module, VMPAL-EVAP for valve terminal MPA-L	675	– FBA-PB	fba-pb
Electrical plug-in base, MHAP-PI	mhap	Fieldbus adapter for CANopen and DeviceNet, FBA-CO for motor unit MTR-DCI	437
Electrical pressure regulator, MS6-LRE, MS series	ms6-lre	Fieldbus adapter for PROFIBUS, FBA-PB for motor unit MTR-DCI	437
Electronic controllers, CECC	964	Fieldbus connection	
Electronics module		– CPX-AB-2-M12-RK for terminal CPX	713
– For terminal CPX	714	– CPX-AB-2-M12-RK for terminal CPX-P	984
– For terminal CPX-P	985	– FBA-1-KL-5POL for terminal CPX	713
Emergency buffer		– FBA-1-SL-5POL for terminal CPX	713
– NPE for spindle axis EGC-BS	328	– FBA-1-SL-5POL for terminal CPX-P	984
– NPE for spindle axis EGC-HD-BS	338	– FBA-2-M12-5POL for terminal CPX	713
– NPE for toothed belt axis EGC-HD-TB	358	– FBA-2-M12-5POL for terminal CPX-P	984
– NPE for toothed belt axis EGC-TB	348	– FBS-SUB-9 for terminal CPX	712
Encoder cable		– FBS-SUB-9 for terminal CPX-P	984
– NEBM	nebm	– FBSD-KL-2x5POL for terminal CPX	713
– NEBM for motor controller CMMO-ST	304, 462	– FBSD-KL-2x5POL for terminal CPX-P	984
– NEBM for servo motors	429	– NECU-M for terminal CPX	713
– NEBM for stepper motors	443	– NECU-M for terminal CPX-P	984
Encoder interface, CECX-C-2G	cecx	Fieldbus interface	
Encoder plug		– CECX-B-CO	cecx
– NECC for motor controller CMMD-AS	449	– CECX-F-PB-S-V	cecx
– NECC for motor controller CMMP-AS	458	– CECX-F-PB-V1	cecx
– NECC for motor controller CMMS-AS	453	Fieldbus module, CTEU	cteu
– NECC for motor controller CMMS-ST	466	Fieldbus node, CPX-FB for terminal CPX	712

Designation	Page/online	Designation	Page/online
Filter		– SFAM	sfam
– ESF	esf	– SFE3	sfe3
– LF, D series, metal	lf	– SFET	sfet
– MS12-LF, MS series	ms12-lf	Fluid plates	1005
– MS4/MS6-LF, MS series	ms4-lf	FluidDraw, GSWF, software	gswf
– MS9-LF, MS series	ms9-lf	Fluidic muscle, MAS, with screwed connection	mas
Filter cartridge		Fluidic muscle, with press-fitted connection, DMSP	dmsp
– MS-LFP-C for MS series	892	Food compatibility to HACCP	1048
– MS-LFP-E for MS series	892	Foot mounting	
Filter combination, LFMB, D series, metal	lfmba	– CRHNC for standard cylinder DSBF-C to ISO 15552	60
Filter regulator		– EAHF for electric cylinder EPCO	302
– LFR-DB, D series, polymer	lfr	– HBN for round cylinder DSNU/ESNU	99
– LFR, D series, metal	lfr	– HBN for standard cylinder to ISO 6432	85
– LFR, D series, polymer	lfr	– HNA for compact cylinder to ISO 21287	114
– LFRS, D series, metal	lfrs	– HNC for electric cylinder DNCE	318
– MS-LFR, MS series	828	– HNC for electric cylinder ESBF	310
Filter silencer, LFU	lfu	– HNC for short-stroke cylinder ADVC/AEVC	131
Fine and micro filter		– HNC for standard cylinder DSBG to ISO 15552	41, 50
– LFMA, D series, metal	lfma	– HNC for standard cylinder to ISO 15552	67
– LFMB, D series, metal	lfmb	– HNCE for electric cylinder DNCE	318
– MS12-LFM, MS series	ms12-lfm	– HPC for linear drive DGC	154
– MS4/MS6-LFM, MS series	ms4-lfm	– HPE for spindle axis EGC-BS	328
– MS9-LFM, MS series	ms9-lfm	– HPE for toothed belt axis EGC-TB	350
Finger lever valve		– HPE for toothed belt axis ELGA-TB	380
– H, 4/3-way valve	h-4/3	Foot valve	
– TH, 3/2-way valve	th-3	– F, 3/2-way valve	f-3
– TH, 5/2-way valve	th-5	– F, 5/2-way valve	f-5
– TH/O-3-PK-3, 3/2-way valve	n_vpk	– FO, 3/2-way valve	fo-3
– THO, 3/2-way valve	th-3	– FO, 5/2-way valve	fo-5
– VHEM-L	vhem-l	Foot valve with detent	
Flange mounting		– FP, 3/2-way valve	fp-3
– CRFNG for standard cylinder DSBF-C to ISO 15552	60	– FP, 5/2-way valve	fp-5
– EAHH for electric cylinder EPCO	302	– FPB, 3/2-way valve	fpb-3
– EAHH for electric cylinder ESBF	311	– FPB, 5/2-way valve	fpb-5
– FBN for round cylinder DSNU/ESNU	99	Fork light barrier, SOOF	soof
– FBN for standard cylinder to ISO 6432	85	Freewheel unit	
– FNC for compact cylinder to ISO 21287	114	– FLSM for swivel module DSM	198
– FNC for electric cylinder DNCE	318	– FLSM for swivel module DSM-B	213
– FNC for electric cylinder ESBF	310	Front panel valve	
– FNC for short-stroke cylinder ADVC/AEVC	131	– SV, 3/2-way valve	sv-3
– FNC for standard cylinder DSBG to ISO 15552	41, 50	– SV, 5/2-way valve	sv-5
– FNC for standard cylinder to ISO 15552	67	– SV/O, 2x3/2-way valve	sv/o
Flanged cylinder		– SVOS, 3/2-way valve	svos
– DFK, double-acting	dfk	– SVS, 3/2-way valve	svs
– EFK, single-acting	efk	– SVS, 4/2-way valve	svs
Flanged precision pressure gauge, FMAP	fmap	Function blocks	1015
Flanged pressure gauge, FMA	fma	Functional earth	1052
Flat cable, KASI, for AS-i system components	kasi		
Flat cylinder			
– DZF, double-acting	dzf	G	
– DZH, double-acting	dzh	Gear unit	
– EZH, single-acting	ezh	– EMGA-SAS	475
Flow control plate, VABF for valve terminal VTSA	638	– EMGA-SST	473
Flow control valve with barbed connector, GRLO, standard	grlo	Gripper, see Bernoulli gripper, suction gripper; Parallel gripper	
Flow control valve with female thread		Guide unit, EAGF	eagf
– GRLO, mini	grlo	Guide unit for standard cylinder	
– GRLO, standard	grlo	– FEN	fen
– GRO, in-line installation	gro	– FENG	feng
Flow control valve with push-in connector QS		Guided drive	
– GRGO, mini	grlo	– DFC, mini	dfc
– GRLO, mini	grlo	– DFM	271
– GRO, in-line installation	gro	– DFME-LAS	dfme-las
Flow control/silencer		– DFP, double-acting	dfp
– GRU	gru	– DGRF, Clean Design	dgrf
– VFFK	615	H	
Flow control/silencer combination, GRE, see Basic valve LC		H-rail mounting	
Flow indicator, SFEV	sfev	– CAFM-F1-H for adapter CAPC	660
Flow sensor		– VAME for valve terminal VTUG	659
– SFAB	sfab	H-rail mounting for VUVG, VAME-T-M4	595

Designation	Page/online	Designation	Page/online
Hand lever valve		– IBS-6x10 for terminal CPX	714
– H, 3/2-way valve	n_v14	– IBS-6x10 for terminal CPX-P	985
– H, 5/2-way valve	n_v14	– IBS-6x10 for valve terminal MPA-L	672
– VHER	vher	– KM	km
Hand slide valve		– KMC	kmc
– VBOH	vboh	– MH	mh
– W, 3/2-way valve	w-3	– SBS	sbs
Handling module		– SIEZ-LB	siez-lb
– HSP	hsp	– SIEZ-LB for inductive proximity sensor	758
– HSW-AE, electric	hsw	– SIEZ-LB for opto-electronic sensors	787
– HSW-AP, pneumatic	hsw	Inscription label holder	
– HSW-AS, without drive	hsw	– ASCF for valve terminal VTSA	639
Heavy-duty palm button valve, PV-3-1/8, 3/2-way valve	n_v18	– ASCF-H for valve terminal VTUG	660
Height compensator, VAL	val	– ASLR-D-L1 for valves VUVG, valve terminal VTUG	659
Hex nut		– CPV10-VI-ST	cpv10-vi-st
– MS-WRS for MS series	889	– CPV14-VI-ST	cpv14-vi-st
– MSK	msk	– CPV18-VI-ST	cpv18-vi-st
High-force cylinder, ADNH, standard hole pattern	adnh	– CPVSC1-ST	cpvsc1-st
Hinge cylinder		– CPX-ST	cpx-st
– DW	dw	– IBT	ibt
– DWA	dwa	– MN2H-BZT	mn2h-bzt
– DWB	dwb	– MVH-BZ	mvh-bz
– DWC	dwc	– VMPA1-ST	vmpa1-st
Hollow bolt		– VMPAL-ST for valve terminal MPA-L	672
– VT	vt	Inscription label, ASLR	743, 753
– VT for manifold block PRS, Tiger Classic valve	607	Inscription label holder for valves VUVG, ASLR-D-L1	595
– VT for manifold rail PAL, Tiger Classic valve	607	Insert, see Time delay insert	
Hose clip, SK	sk	Installation kit, HMZAS, for protective conduits	hmzas
Housing for rotary module ERMB, EAPS-...-H	391	Installation system	
Hydraulic cushioning cylinder		– CPI	ctec
– DYHR	dyhr	– CTEL	ctel
– YD	yd	Integrated solutions	1009
– YZL	yzl	Interface, see Electrical interface, fieldbus interface, encoder interface	
I-Port interface, CPX-CTEL for terminal CPX	714	Interlinking block	
I-Port interface, outlet on top, VMPAL-EPL for valve terminal MPA-L	669	– CPX-GE-EV for terminal CPX	716
Identbox, CHB-IB	chb-ib	– CPX-M-GE-EV for terminal CPX-P	986
Illuminating seal		Intermediate plate, NZV-VDMA for standard valves for connecting the sizes 02 and 01, to ISO 15407-1	547
– MC-LD	n_mc_ld	Intrinsically safe circuits	969
– MC-LD for N1 solenoid coil, to ISO 5599-1	567	ISO 5599-1, Standard valves	549
– ME-LD	n_mc_ld	Isolating disc, NSC-ISO for creating pressure zones, to ISO 5599-1	568
– MEB-LD	n_mc_ld		
– MEB-LD for plug type C, to ISO 15407-1	548	J	
– MF-LD	n_mc_ld	Junction box, HMZV, for protective conduits	hmzv
– MF-LD for F solenoid coil	607		
– MV-LD	n_mc_ld	L	
Indicator insert		Leakage detection	1030
– MCL	mcl	Limit stop signal generator, SDV, 3/2-way valve	sdv
– MCLZ	mclz	Limit switch attachment, QH-DR	qh-dr
– MFL	mfl	Limit switch attachments	
– MFLZ	mflz	– DAPZ	dapz
Individual sub-base		– SRBF	srbf
– NAS-VDMA for standard valves, to ISO 15407-1	547	Limit valve, SDK, 3/2-way valve	sdk
– NAU-ISO for standard valves, ports underneath, to ISO 5599-1	567	Linear actuator, DLP, Copac	dlp
– VABS for valve terminal VTSA	641	Linear drive	
Inductive proximity sensor, see Proximity sensor, inductive		– ADNE-LAS	adne-las
Input module		– DDLI, integrated displacement encoder	ddli
– CECX-A-4E-V	cecx	– DFPI, with displacement encoder	dfpi
– CECX-D-16E	cecx	– DGC-G, basic design	143
– CECX-D-E8A	cecx	– DGC-GF, with plain-bearing guide	143
– CECX-E-E-T-P	cecx	– DGC-HD, with heavy-duty guide	171
– CTSL	ctsl	– DGC-KF, with recirculating ball bearing guide	143
Inscription label		– DGCI, with displacement encoder	dgci
– ASLR, for proximity sensor	743, 753	– DGO, magnetic force transmission	dgo
– BZ	bz	– DGP, basic design	dgp
– HWF	hwf	– DGPI, with displacement encoder	dgpi
– IBS	ibs	– DGPII, with displacement encoder	dgpil
– IBS-6x10 for standard valves, to ISO 15407-1	548	– DGPL, with guide	dgpl
		– SLG, flat design	slg

Designation	Page/online	Designation	Page/online
– SLM, with guide	slm	Motor cable	
Linear drive unit, SLE, with recirculating ball bearing guide	sle	– KMTR	kmtr
Linear drive, with air bearings and linear motor, ELGL	elgl	– KMTR E	kmtr e
Linear gantry, DHSL	dhsl	– NEBM for motor controller CMMO-ST	461
Linear module, HMP	hmp	– NEBM for servo motor	429
Linear/swivel clamp, CLR	clr	– NEBM for stepper motor	304, 443
Logic component, see Amplifier module, AND gate, OR gate		Motor controller	
Low consumption air gun, LSP	lsp	– CMMD-AS, for servo motor	446
Lubricator		– CMMO-ST for electric cylinder EPCO	460
– LOE, D series, metal	loe	– CMMP-AS, for servo motor	454
– MS12-LOE, MS series	ms12-loe	– CMMS-AS	cmms-as
– MS4/MS6-LOE, MS series	ms4-loe	– CMMS-AS, for servo motor	450
– MS9-LOE, MS series	ms9-loe	– CMMS-ST, for stepper motor	463
		– SEC-ST	sec-st
M		– SFC-DC	sfc-dc
M5 Compact System	m5 compact	– SFC-LACI	sfc-laci
Magnetventil, 2/2-Wegeventil, VZWM	vzwm-l	Motor unit, MTR-DCI	434
Maintenance	1022	Mounting, SMBN-10, For proximity sensor for C-slot	753
Manifold block, PRS for Tiger Classic valve	607	Mounting bracket	
Manifold block for AS-interface, CPX-AB for valve terminal VTSA	639	– MS-WB for MS series	889
Manifold duct plates	1009	– MS-WBM for MS series	889
Manifold rail		– MS-WP for MS series	889
– PAL for Tiger Classic valve	607	– MS-WPB for MS series	889
– VABM-L1-10HW for VUVG, sub-base valve M7	588	– MS-WPE for MS series	889
– VABM-L1-10S for VUVG, in-line valve M5/M7	576	– MS-WPM for MS series	889
– VABM-L1-10W for VUVG, sub-base valve M5	588	– MS-WR for MS series	889
– VABM-L1-14S for VUVG, in-line valve G1/8	582	– SOEZ-HW for opto-electronic sensors	787
– VABM-L1-14W for sub-base valve VUVG, G1/8	594	– VAME for valve terminal VTSA	642
Manifold sub-base		– VMPAL-BD for valve terminal MPA-L	676
– NAV-ISO for standard valves, to ISO 5599-1	567, 568	Mounting components, see Central mounting; Centring pin; Centring sleeve; Clevis foot; Right-angle clevis foot; Slot nut; Threaded pin; Trunnion support	
– NAW-VDMA, for standard valves to ISO 15407-1	547	Mounting kit	
– VABV for valve terminal VTSA	639	– CRSMBR for proximity sensor, for round cylinder DSNU/ESNU	100
Manual	documentation	– SMBR	
Manual override, HAB, for non-return valve HGL	hab	For proximity sensor for C-slot	753
Manuals	documentation	For proximity sensor for T-slot	743
Measured-value transducer, DADE	dade	Heat-resistant, corrosion-resistant, For proximity sensor for T-slot	743
Measuring module, CPX-CMIX	cpx-cmix	– SMBR for proximity sensor, for standard cylinder DSNU to ISO 6432	85
Measuring unit, ASDLP	asdlp	– WSM, For proximity sensor for swivel module DSM	753
Membrane air dryer		– WSM for proximity sensor, for swivel module DSM	198
– LDM1, D series, metal	ldm1	Mounting plate	
– MS4/MS6-LDM1, MS series	ms4-ldm1	– HSM for swivel module DSM-B	213
Memory card		– MS-AEND for MS series	889
– CPX-SK for terminal CPX	717	Mounting plates	1005
– CPX-SK for terminal CPX-P	987	Multi-pin plug distributor, NEDU	nedu
Memory module, SBA-2N	sba	Multi-pin plug socket, NECA	neca
Micro reflex sensor, RML	rml	Multi-plug, ksv	ksv
Micro switch, S-3	s-3	Multi-position cylinder, ADNMM, standard hole pattern	adnm
Midi pneumatic, see Solenoid valve MEBH, MEH, MOEBH, MOEH, JMEBH, JMEH; pneumatic valve VL, J		Multi-position kit	
– Pneumatic valve	mebh	– DPNA for compact cylinder to ISO 21287	114
– Solenoid valve	mebh	– DPNC for short-stroke cylinder ADVC/AEVC	132
Mini guided drive, DFC	dfc	– DPNC for standard cylinder DSBC to ISO 15552	43
Mini slide		– DPNC for standard cylinder DSBG to ISO 15552	53
– DGSL	250	– DPNC for standard cylinder to ISO 15552	67
– EGSL, electric	364	Multi-socket, KDVF	kdvf
– SLF, flat design	slf	Multi-tube connector, KM	km
– SLS, slim design	sls	Multi-tube holder, KK	kk
– SLT, compact design	slt	Multimount cylinder	
– SLTE, electric	slte	– DMM, double-acting	dmm
MLC-8, for pneumatic feed unit BV		– DMML, double-acting, non-rotating	dmml
– Pneumatic valve	mlc	– EMM, single-acting	emm
– Solenoid valve	mlc	– EMLL, single-acting, non-rotating	emml
Module connector		Multiple distributor	
– MS-AMV for MS series	892	– QSLV2, Quick Star	933
– MS-ARMV for MS series	892	– QSLV3, Quick Star	933
– MS-MV for MS series	889	– QSLV4, Quick Star	934
– MS-MVM for MS series	889	– QSLV6, Quick Star	934
– MS-RMV for MS series	892	– QSQ, Quick Star	935
Moment compensator, FKC for linear drive DGC	154	– QSYTF	qsytf

Designation	Page/online	Designation	Page/online
Muscle, Pneumatic, see Fluidic muscle			
N			
N1 solenoid coil, MSN1 for standard valves, to ISO 5599-1	569		
Non-return valve			
– HA	h-qs		
– HB	h-qs		
– HGL, piloted	608		
– VBNF	vbnf		
Non-return valve with female/male thread, H	h-qs		
Non-return valve with push-in connector QS, H	h-qs		
NOT module, see OR gate			
O			
On-off valve			
– HE, D series, metal	he		
– HEE, D series, metal	hee		
– HEP, D series, metal	hep		
– MS-EE, MS series	862		
– MS-EM, MS series	855		
– MS-EM1, MS series	855		
One-way flow control valve			
– GG	gg		
– GGO	gg		
– GRF for mounting frame 2N	m5 compact		
– GRLA, standard	611		
– GRLZ, standard	611		
– GRR	gr		
– GRXA-HG	grxa-hg		
– VFOC	vfoc		
– VFOF, flat	613		
– VFOF, function combination	614		
One-way flow control valve with female thread			
– GR, in-line installation	gr		
– GRA, in-line installation	gr		
One-way flow control valve with push-in connector QS, GR, in-line installation	gr		
Operating conditions			
– Drives	1040		
– Pneumatics	1032		
– Valves	1038		
Operating phase	1022		
Operator package			
– GSIB, software	gsib		
– P.BP, software	software		
Operator unit			
– CDPX, with touchscreen	cdpx		
– CDSA, with touchscreen	cdsa		
– CPX-MMI, text-based	cpx-mmi		
– FED, text-based	fed		
– FED, with touchscreen	fed		
Opto-electronic sensors			
– SOEG-, SOEL-	771		
– SOEG-L	778		
– SOEG-RSP	774, 784		
– SOEG-RT	772		
– SOEG-S/E	776		
– SOEL-RSP	782		
– SOEL-RT	780		
OR gate			
– OS	os		
– VLO	os		
Output module			
– CECX-A-4A-V	cecx		
– CECX-A-4E4A	cecx		
– CECX-D-14A-2	cecx		
P			
Padlock, LRVS-D for MS series	891		
Paint-wetting impairment substances	1049		
		Parallel gripper	
		– DHPS	483
		– HGP	hgp
		– HGPC	hgpc
		– HGPD	hgpd
		– HGPL	hgpl
		– HGPLE, electric, sturdy with long stroke	hgple
		– HGPM	hgpm
		– HGPP	hgpp
		– HGPT-B	hgpt
		Parallel kit	
		– EAMM-U for electric cylinder DNCE	320
		– EAMM-U for electric cylinder ESBF	312
		– EAMM-U for mini slide EGSL	367
		– EAMM-U for rotary/lifting module EHMB	401
		– EAMM-U for spindle axis EGC-BS	329
		– EAMM-U for spindle axis EGC-HD-BS	339
		Passive guide axis	
		– DGC-FA	dgc-fa
		– EGC-FA	egc
		– ELFR	elfr
		– FDG	fdg
		– FDG-ZR-RF	fdg
		PE, Pressure switch	pe
		Pilot valve, VSCS for solenoid valve VSVA, to ISO 15407-1	548
		Pipe	
		– PQ-AL	n_070100
		– see Plastic-coated metal tube	
		Pipe and tubing cutter, ZRS	zrs
		Pipe clamp, PQ	pq
		Pipe cutter, ZR	zr
		Piston rod attachments, see Adapter; Coupling piece; Hex nut; Rod clevis; Rod eye; Self-aligning rod coupler	
		Planar surface gantry, EXCM	excm
		Plastic pipe, PQ-PA	pq
		Plastic tubing	
		– see Spiral plastic tubing	
		– PAN	pan
		– PAN-R, for high pressure range	pan-r
		– PAN-VO, flame-retardant	pan-vo
		– PCN	pcn
		– PFAN, approved for foodstuffs	pfan
		– PLN	pln
		– PU	pu
		– PUN-CM	pun-cm
		– PUN-VO, flame-retardant	pun-vo
		Plastic tubing, standard O.D.	
		– PEN, resistant to cleaning agents	903
		– PUN	904, 907
		– PUN-H, hydrolysis-resistant	905, 907
		Plastic-coated metal tube, PM	n_070100
		Plug	
		– FBS	fbs
		– FBS-RJ45	fbs-rj45
		– FBS-SUB	fbs-sub
		– FBS-SUB-9-WS	fbs-sub-9
		– NECC, for controllers	necc
		– NECU	necu
		– PS1-SAC	ps1
		– PS1-ZC	ps1
		– SD-SUB	sd-sub
		– SEA	sea
		– SEA-M12 for I-Port/IO-Link, valve terminal VTUG	660
		– SEA-M12 for valve terminal MPA-L	669
		Plug assortment, NEKM	nekm
		Plug connector, NECU-FC for valve terminal MPA-L	676
		Plug for controllers CECC, NECC	967
		Plug socket	
		– FBSD	fbsd

Designation	Page/online	Designation	Page/online
– MSSD	mssd	– NTSD for terminal CPX	717
– MSSD for F solenoid coil	607	Power supply cable, KPWR-MC for motor unit MTR-DCI	437
– MSSD-C for N1 solenoid coil, to ISO 5599-1	567	Power supply module, VMPAL-SP for valve terminal MPA-L	675
– SD-SUB	sd-sub	Power supply socket, NTSD	ntsd
– SEA-M12, for EB solenoid coil, to ISO 5599-1	567	Power supply unit	
Plug socket with cable		– CACN	cacn
– KMC	kmc	– SVG	svg
– KME	kme	– SVG-SEC for motor controller CMMS-ST	466
– KMEB	kmeb	Precision flow control valve, GRPO	grpo
– KMF	kmf	Precision one-way flow control valve, GRP	grp
– KMH	kmh	Precision pressure gauge, MAP	map
– KMPPE	kmppe	Precision pressure regulator	
– KMV	kmv	– LRP	lrp
– KMYZ	kmyz	– LRPS	lrps
– SIM	sim	– MS6-LRP, MS series	ms6-lrp
Plug socket with cable for E-box VAVE, NEBV-H1G2	595	– MS6-LRPB, MS series	ms6-lrpb
Plug-in card for additional I/Os, CAMC for motor controller CMMD-AS	449	Pressure booster, DPA	dpa
Plug-in card for fieldbus interface		Pressure gauge	
– CAMC for motor controller CMMD-AS	449	– See Flanged pressure gauge, flanged precision pressure gauge, pressure gauge kit, vacuum gauge	
– CAMC for motor controller CMMP-AS	458	– MA-EN	ma
– CAMC for motor controller CMMS-AS	453	– PAGN	pagn
– CAMC for motor controller CMMS-ST	466	– PAGN for regulator plate VABF	638
Pneumatic feed unit, BV	bv	Pressure gauge kit, DPA-MA-SET for pressure booster DPA	dpa
Pneumatic limit valve, RWN/O, 3/2-way valve	rwn/o-3	Pressure indicator, OH	oh
Pneumatic sensors	Air gap sensor	Pressure regulator	
Pneumatic terminal, LT	lt	– LR-DB, D series, polymer	lr-db
Pneumatic valve		– LR-G	lr-g
– 2x 3/2-way valve VSPA, to ISO 15407-1	542	– LR-QS	lr-qs
– 5/2-way valve VSPA, to ISO 15407-1	542	– LR, D series, metal	lr
– 5/3-way valve VSPA, to ISO 15407-1	542	– LRB-K, manifold combination, D series, metal	lrb
– Basic valve LC	lc	– LRB, D series, metal	lrb
– Cassette valve	cm	– LRBS, D series, metal	lrbs
– Midi pneumatic	mebh	– LRMA-QS	lrma
– MLC-8, for pneumatic feed unit BV	mlc	– LRS-G	lrs-g
– Supplementary range	vl	– LRS, D series, metal	lrs
– VLHE	vlhe	– MS-LR, MS series	839
Pneumatic valve 3/2-way, VL/O for mounting frame 2N	m5 compact	– MS-LRB, MS series	849
Pneumatic valve 5/2-way, VL for mounting frame 2N	m5 compact	Pressure regulator combination, LRB-DB, D series, polymer	lrb-db
Pneumatic valve, 2/2-way valve, VLX	vlx	Pressure regulator plate, VABF, to ISO 15407-1	539
Pneumatic valve, 2x3/2-way valve, VUWG	vuwg	Pressure sensor	
Pneumatic valve, 5/2-way valve		– SDE5	767
– J-B, Tiger 2000	tiger 2000	– SPBA, for solenoid valve VSVA	spba
– J, to ISO 5599-1	iso 5599-1	Pressure sensor with display	
– JD, to ISO 5599-1	iso 5599-1	– SDE1	762
– JMVH-B, Tiger 2000	tiger 2000	– SDE3	sde3
– MVH-B, Tiger 2000	tiger 2000	– SPAB	spab
– VL-B, Tiger 2000	tiger 2000	Pressure switch	
– VL, to ISO 5599-1	iso 5599-1	– PE	pe
– VUWG	vuwg	– PEV	pev
Pneumatic valve, 5/3-way valve		– VPE, for vacuum	vpe
– MVH-B, Tiger 2000	tiger 2000	Pressure transmitter	
– VL-B, Tiger 2000	tiger 2000	– SPT	spte
– VL, to ISO 5599-1	iso 5599-1	– SPTW	sptw
– VUWG	vuwg	Pressure/force graph	1042
Pneumatics interface		Pressure/force table	1041
– VABA for CPX terminal	716	Process automation	1003
– VMPA-FB-EPLM for terminal CPX-P	986	Profile mounting	
Position marker		– EAHF for electric cylinder DNCE	319
– SMM-10, For proximity sensor for C-slot	753	– EAHF for electric cylinder ESBF	311
– SMM-8, For proximity sensor for T-slot	743	– EAHF for mini slide EGSL	368
Position sensor, SMH-S1	smh-1	– MUC for linear drive DGC	154
Position transmitter for T-slot		– MUE for mini slide EGSL	368
– Magnetic, SMAT-8E	smat-8e	– MUE for spindle axis EGC-BS	328
– Magnetic, SMAT-8M	smat-8m	– MUE for spindle axis EGC-HD-BS	338
Positioner, CMSX	cmsx	– MUE for toothed belt axis EGC-HD-TB	359
Positioning axis, DMES	dmes	– MUE for toothed belt axis EGC-TB	350
Power supply		– MUE for toothed belt axis ELGA-TB	380
– NECU-G78 for terminal CPX	717	Profile solutions	1017
– NECU-G78 for terminal CPX-P	987		

Designation	Page/online	Designation	Page/online
Programming cable			
– KDI	kdi	– SIEN, standard switching distance, polyamide housing	756
– KDI-MC for motor unit MTR-DCI	437	Proximity sensor, inductive for T-slot, SIES-8M	759
– PS1 for motor controller CMMD-AS	449	Pulse oscillator	
– PS1 for motor controller CMMP-AS	458	– TAA	taa
– PS1 for motor controller CMMS-AS	453	– TAB	tab
– PS1 for motor controller CMMS-ST	466	– VLG	vlg
– PS1-ZK11	cmms-st	Push-in bulkhead connector	
Proportional directional control valve			
– MPYE	mpye	– NPQP-H	929
– MPYE, 5/3-way valve	mpye	– QSMS, Quick Star, mini	911
– VPWP	vpwp	– QSS, Quick Star	918
Proportional media valve, VZQA			
Proportional pressure regulator			
– MPPE, 3-way pressure regulator	mppe	Push-in connector	
– MPPES, 3-way pressure regulator	mppes	– NPQP-D	929
Proportional pressure regulator, 3/2-way valve			
– VPPE	vppe	– QS, Quick Star	917
– VPPM	vppm	– QSM, Quick Star, mini	911
Proportional pressure regulator, 5/3-way valve, VPWP			
Protection classes			
– EN 60529	1050	– QSW, Quick Star	925
– IEC 60144	1050	Push-in fitting	
Protective conduit			
– MKG	mkg	– CQ	n_36446
– MKR	mkr	– CRQS, stainless steel	crqs
– MKR for rotary/lifting module EHMB	405	– NPQM	npqm
– MKV	mkv	– NPQP-D	929
Protective conduit fitting, EASA for rotary/lifting module EHMB			
Protective earth			
Protective extra-low voltage PELV			
Protective metal conduit, MK			
Proximity sensor			
– CRSMEO-4, corrosion-resistant, round design	crsmeo-4	– QS-B, standard	qs-b
– SIEA, inductive, analogue output	siea	– QS-F, metal	qs-f
– SIED, inductive, standard switching distance, for DC and AC voltage	sied	– QS-V0, flame-retardant	qs-v0
– SIED, inductive, standard switching distance, for DC and AC voltage, polyamide housing	sied	– QS, Quick Star	916
– SIES, inductive, special design	sies	– QSF, Quick Star	918
– SME-10, For C-slot, Magnetic reed	744	– QSM-B, mini	qsm-b
– SME-8, For T-slot, Magnetic reed	730	– QSM, Quick Star, mini	910
– SMEO-1, block design	smeo-1	– QSMF, Quick Star, mini	911
– SMEO-4U, round design	smeo-4	– QSW, Quick Star	925
– SMEO, round design, for round cylinder DSNU/ESNU	100	Push-in L-connector	
– SMEO, round design, for standard cylinder to ISO 6432	86	– NPQP-L	930
– SMPPO-1, block design, pneumatic	smpo	– QSL, Quick Star	921
– SMPPO-8E, for T-slot, block design	smpo	– QSML, Quick Star, mini	913
– SMT-10, For C-slot, Magneto-resistive	744	Push-in L-fitting	
– SMT-8, For T-slot, Magneto-resistive	731	– NPQP-L	930
– SMT0-1, block design	smt0-1	– NPQP-LQ	930
– SMT0-4U, round design	smt0-4	– QSL, Quick Star	919
– SMT0, round design, for round cylinder DSNU/ESNU	100	– QSLF, Quick Star	921
– SMT0, round design, for standard cylinder to ISO 6432	86	– QSLV, Quick Star	922
– SMTSO-1, block design	smtso-1	– QSML, Quick Star, mini	912
Proximity sensor for T-slot			
– Magnetic reed, heat-resistant, SMEO-8E	smeo	– QSMLV, Quick Star, mini	913
– Magnetic reed, SMEO-8E	smeo	Push-in long L-fitting	
– Magnetic, SMAT-8E	smat-8e	– QSL, Quick Star	920
– Magnetic, SMAT-8M	smat-8m	– QSMLL, Quick Star, mini	912
– Magneto-resistive, corrosion-resistant, CRSMT-8	crsmt-8	– QSMLLV, Quick Star, mini	913
– Magneto-resistive, SMT0-8E	smt0	Push-in T-connector	
– Magneto-resistive, welding field immune, SMTSO-8E	smtso	– NEDU	nedu
Proximity sensor, block design, Magneto-inductive, SMT-C1			
Proximity sensor, inductive			
– SIE...	754	– NPQP-T	931
– SIEF...-WA, reduction factor 1 for all metals, welding field immune	sief	– QSMT, Quick Star, mini	914
– SIEF, reduction factor 1 for all metals	sief	– QST, Quick Star	923
– SIEH, increased switching distance	sieh	– QSTF, Quick Star	924
– SIEH, increased switching distance, stainless steel housing	sieh	– QSTL, Quick Star	924
– SIEN, standard switching distance	755	Push-in Y-connector	
		– NPQP-Y	931
		– QSMY, Quick Star, mini	915
		– QSY, Quick Star	926
		Push-in Y-fitting	
		– NPQP-Y	931
		– QSY, Quick Star	926
		– QSYL, Quick Star	927
		– QSYLV, Quick Star	927
		Push-on flange	
		– FWSR for swivel module DSM	198
		– FWSR for swivel module DSM-B	213

Designation	Page/online	Designation	Page/online
Pushbutton valve, see Heavy-duty palm button valve			
Pushbutton valve		Rod clevis	
– F-3-M5, 3/2-way valve n_vm5		– CRSG for standard cylinder DSBF-C to ISO 15552 60	
– K-3-M5, 3/2-way valve n_vm5		– CRSG, stainless steel crsg	
– K/O-3-PK, 3/2-way valve n_vpl		– SG sg	
– T-5/3-1/4, 5/3-way valve n_v14		– SG for compact cylinder to ISO 21287 115	
– VHEM-P vhem-p		– SG for electric cylinder DNCE 311, 318	
Q		– SG for electric cylinder EPCO 302	
Quarter turn actuator		– SG for round cylinder DSNU/ESNU 99	
– DAPS, Sypar daps		– SG for short-stroke cylinder ADVC/AEVC 132	
– DFPB, for process automation dfpb		– SG for standard cylinder DSBC to ISO 15552 42	
– DRD, Copar, double-acting drd		– SG for standard cylinder DSBG to ISO 15552 51	
– DRE, Copar, single-acting dre		– SG for standard cylinder to ISO 15552 68	
Quick connector, CK n_ck		– SG for standard cylinder to ISO 6432 85	
Quick coupling plug		– SGA sga	
– KS ks1		– SGA for compact cylinder to ISO 21287 115	
– KSS6 kds6		– SGA for electric cylinder DNCE 310, 318	
Quick coupling socket		– SGA for electric cylinder EPCO 302	
– KD kd1		– SGA for round cylinder DSNU/ESNU 101	
– KDMS6 kdms6		– SGA for short-stroke cylinder ADVC/AEVC 132	
– KDS6 kds6		– SGA for standard cylinder DSBC to ISO 15552 42	
Quick exhaust valve		– SGA for standard cylinder DSBG to ISO 15552 51	
– SE se		– SGA for standard cylinder to ISO 15552 68	
– SEU seu		Rod eye	
– VBQF vbqf		– CRSGS for standard cylinder DSBF-C to ISO 15552 60	
Quickstepper, FSS fss		– CRSGS, stainless steel crsgs	
R		– SGS sgs	
Radial gripper		– SGS for compact cylinder to ISO 21287 114	
– DHRS 497		– SGS for electric cylinder DNCE 311, 318	
– HGRC hgrc		– SGS for electric cylinder EPCO 302	
– HGRT hgrr		– SGS for rotary/lifting module EHMB 405	
Ready-to-install solutions 1000		– SGS for round cylinder DSNU/ESNU 99	
Reducing nipple, D d-1		– SGS for short-stroke cylinder ADVC/AEVC 132	
Reducing sleeve		– SGS for standard cylinder DSBG to ISO 15552 42, 51	
– DAYH for mini slide DGSL 256		– SGS for standard cylinder to ISO 15552 68	
– QMR qmr		– SGS for standard cylinder to ISO 6432 85	
Reflector, SOEZ-RFS for opto-electronic sensors 787		Roller lever valve	
Reflector foil, SOEZ-RFF for opto-electronic sensors 787		– R, 3/2-way valve r-3	
Reflector for laser light, SOEZ-RFL for opto-electronic sensors 787		– R, 5/2-way valve r-5	
Reflex sensor, RFL rfl		– R/O, 3/2-way valve r/o-3	
Regulator plate		– RO, 3/2-way valve ro-3	
– VABF for valve terminal VTSA 637		– ROS, 3/2-way valve ros-3	
– VMPA1-B8 for valve terminal MPA-L 671		– RS, 3/2-way valve rs-3	
Releasing tool, QSO, for tubing qso		– RS, 4/2-way valve rs-4	
Repair 1022		Roller lever valve with idle return	
Repair service 1023		– L, 3/2-way valve l-3	
Resistance to media 1049		– L, 5/2-way valve l-5	
Resolver cable, NEBM for servo motors 429		– L/O, 3/2-way valve l/o-3	
Retainer		– LO, 3/2-way valve lo-3	
– EAYH for spindle axis EGC-HD-BS 338		– LOS, 3/2-way valve los-3	
– EAYH for toothed belt axis EGC-HD-TB 358		– LS, 3/2-way valve ls-3	
Reverse jet pulse valve, VZWE, 2/2-way valve vzwe		– LS, 4/2-way valve ls-4	
Right-angle clevis foot		Rotary and semi-rotary drive, see Swivel modules	
– LQG lqg		Rotary distributor, GF gf	
– LQG for compact cylinder to ISO 21287 115		Rotary indexing table, DHTG dhgt	
– LQG for electric cylinder DNCE 310, 318		Rotary lifting modules, electric, EHMB 396	
– LQG for electric cylinder EPCO 302		Rotary module, electric, ERMB 389	
– LQG for round cylinder DSNU/ESNU 101		Rotary push-in fitting, QSR, standard qsr	
– LQG for short-stroke cylinder ADVC/AEVC 132		Round cylinder	
– LQG for standard cylinder DSBC to ISO 15552 42		– CRDSNU, standard cylinder, stainless steel crdsnu	
– LQG for standard cylinder DSBG to ISO 15552 51		– CRDSW, double-acting, stainless steel crdsw	
– LQG for standard cylinder to ISO 15552 68		– DG, double-acting, miniature cylinder dg	
Ring piece		– DSNU, double-acting 91	
– LK lk		– EG-PK, single-acting, micro cylinder eg-pk	
– TK tk		– EG, single-acting, miniature cylinder eg	
		– ESNU, single-acting 91	
		Rubber hose, P p	
		Rubber tubing, see Plastic tubing	

Designation	Page/online	Designation	Page/online
S			
Safety system, CMGA	467	– LFRS, D series, metal	lfrs
Sales and service network, International	1055	– MSB, MS series	814
Screening plate		Service units, MS series	807
– CPX-AB-S-4-M12 for terminal CPX	715	Servo motor	
– CPX-AB-S-4-M12 for terminal CPX-P	985	– EMME-AS	emme
Screw, M10 for short-stroke cylinder ADVC/AEVC	131	– EMMS-AS	415
Sealing ring		Sheet-metal constructions	1013
– CRO	937	Shock absorber	
– O	937	– DYEF	dyef
– OK	938	– DYEF for mini slide DGSL	256
– OL	937	– DYEF for swivel module DSM-B	213
Sealing ring assortment		– DYEF-S for mini slide DGSL	256
– OK-S1	938	– DYSC	dysc
– OL-S1	937	– DYSC for swivel module DSM-B	213
Selector switch, HW, 3/6-way valve	hw	– DYSR	dysr
Self-aligning rod coupler		– DYSW	dysw
– FK	fk	– DYSW for mini slide DGSL	256
– FK for compact cylinder to ISO 21287	115	– DYSW for rotary/lifting module EHMB	405
– FK for electric cylinder DNCE	311, 318	– YSR-C	ysr-c
– FK for electric cylinder EPCO	302	– YSRW	ysrw
– FK for round cylinder DSNU/ESNU	99	– YSRW for linear drive DGC	153
– FK for short-stroke cylinder ADVC/AEVC	133	– YSRW for linear drive DGC-HD with heavy-duty guide	175
– FK for standard cylinder DSBC to ISO 15552	42	– YSRW for toothed belt axis EGC-HD-TB	358
– FK for standard cylinder DSBG to ISO 15552	51	– YSRW for toothed belt axis EGC-TB	348
– FK for standard cylinder to ISO 15552	68	– YSRWJ	ysrwj
– FK for standard cylinder to ISO 6432	85	Shock absorber retainer	
Self-sealing, push-in fitting, QSK, standard	qsk	– EAYH for rotary/lifting module EHMB	405
Semi-rotary drive		– EAYH for toothed belt axis EGC-HD-TB	358
– DRQ	drq	– KYE for spindle axis EGC-BS	328
– DRQD	224	– KYE for toothed belt axis EGC-TB	348
– DRQD-B	224	Short-stroke cylinder	
– DRRD	181	– ADVC, double-acting	123
– DSR, with spigot shaft	dsr	– AEVC, single-acting	123
– DSRL, with hollow flanged shaft	dsrl	Shut-off valve	
Sensing kit, DASI-KT for semi-rotary drive DRRD	188	– HE	he
Sensing kit for rotary module ERMB, EAPS-...-S	391	– HE-LO	he-lo
Sensing kit without housing for rotary module ERMB, EAPS-...-S-WH	391	Signal converter, SVE4	sve4
Sensor box		Silencer	
– SRAP, analogue	srap	– AMTC	amt
– SRBP, binary	srbp	– U	994
Sensor bracket		– UC	uc
– EAPM for toothed belt axis ELGA-TB	379	– UO	uo
– EAPM for toothed belt axis ELGR	387	– UOM	uom
– EAPS-...-SH, for rotary module ERMB	391	– UOMS	uoms
– HWS-EGC for linear drive DGC-HD with heavy-duty guide	175	– UOS-1	uos
– HWS-EGC for spindle axis EGC-BS	328	Silencer extension, UOMS	uoms
– HWS-EGC for spindle axis EGC-HD-BS	338	Sleeve, QM	qm
– HWS-EGC for toothed belt axis EGC-HD-TB	358	Slide unit, SPZ, twin piston	spz
– HWS-EGC for toothed belt axis EGC-TB	348	Slot cover	
– SIEZ for inductive proximity sensor	758	– ABP for spindle axis EGC-BS	328
– SIEZ-8M for proximity sensor	761	– ABP for spindle axis EGC-HD-BS	338
– SL-DSM for swivel module DSM-B	213	– ABP for toothed belt axis EGC-HD-TB	359
Sensor interface, CASM	casm	– ABP for toothed belt axis EGC-TB	349
Sensor socket, SIE-GD	sie-gd	– ABP-5-S for compact cylinder to ISO 21287	116
Sensor bracket, DASP-M4-125-A, for proximity sensors for T-slot	743	– ABP-5-S for guided drive DFM	274
Separator		– ABP-5-S for linear drive DGC	154
– VABD for pressure zone separation for manifold rail VABM-L1-14W	594	– ABP-5-S for short-stroke cylinder ADVC/AEVC	133
– VABD for valve terminal VTUG	659	– ABP-5-S for spindle axis EGC-BS	328
Service	1022	– ABP-5-S for spindle axis EGC-HD-BS	338
Service unit		– ABP-5-S for standard cylinder DSBC to ISO 15552	42
– FRC-DB, D series, polymer	frc	– ABP-5-S for standard cylinder to ISO 15552	68
– FRC, D series, metal	frc	– ABP-5-S for toothed belt axis EGC-TB	349
– FRC, D series, polymer	frc	– ABP-5-S for twin-piston semi-rotary drive DRQD	234
– FRCS, D series, metal	frcs	Slot nut	
– MSB-FRC, MS series	825	– HMBN	hmbn
Service unit combination		– HMBN for linear drive DGC	154
– FRC, D series, metal	frc	– NST	nst
– LFR, D series, metal	lfr	– NST for spindle axis EGC-BS	328
		– NST for spindle axis EGC-HD-BS	338

Designation	Page/online	Designation	Page/online
– NST for toothed belt axis EGC-HD-TB	359	– VMPA1	vmpa1
– NST for toothed belt axis EGC-TB	350	Solenoid valve, 2x3/2-way valve	
– NSTH	nsth	– CDVI5.0, Clean Design	cdvi5.0
– NSTL	nstl	– CPASC1	cpasc1
Socket head screw		– VMPA1	vmpa1
– For mounting kit WSM, for swivel module DSM	198	– VUVG-B	570
– For stop kit KSM, for swivel module DSM	198	– VUVG-B-T1 for valve terminal VTUG	643
SOEG-L, Opto-electronic sensors	778	– VUVG-L	570
SOEG-RSP, Opto-electronic sensors	774, 784	– VUVG-S	570
SOEG-RT, Opto-electronic sensors	772	– VUVG-S-T1 for valve terminal VTUG	643
SOEG-S/E, Opto-electronic sensors	776	Solenoid valve, 3/2-way valve	
SOEL-RSP, Opto-electronic sensors	782	– CDVI5.0, Clean Design	cdvi5.0
SOEL-RT, Opto-electronic sensors	780	– CPASC1	cpasc1
Soft Stop, see End-position controller		– MHA1-3/2, miniature	mh1
Soft-start and quick exhaust valve, MS-SV-C, MS series	875	– MHA2, fast-switching valve	mh2
Soft-start valve		– MHA3, fast-switching valve	mh2
– HEL, D series, metal	hel	– MHA4, fast-switching valve	mh2
– MS-DL, MS series	870	– MHE2, fast-switching valve	mh2
– MS12-DE, MS series	ms12-de	– MHE3, fast-switching valve	mh2
– MS4/MS6-DE, MS series	ms4-de	– MHE4, fast-switching valve	mh2
Soft-start/quick exhaust valve, MS6-SV, MS series	ms6-sv	– MHP1-3/2, miniature	mh1
Software		– MHP2, fast-switching valve	mh2
– See Operator package, software license, diagnostic module		– MHP3, fast-switching valve	mh2
– GSPF	gspf	– MHP4, fast-switching valve	mh2
– GSWF-P5, FluidDraw P5®	gswf	– VMPA1	vmpa1
– GSWF-S5, FluidDraw S5®	gswf	– VOFC	vofc
Software and manual, P.SW	software	– VOFD	vofd
Software GSPF, For configuring, programming, commissioning and maintaining automation solutions	967	– VOVG	vovg
Software licence, GSLO	gslo	– VSNB, to NAMUR	namur
Software tool		– VUVB	vuvb
– Bearing calculation	21	Solenoid valve, 4/2-way valve, VUVB	vuvb
– CoDeSys	software	Solenoid valve, 5/2-way valve	
– Festo Configuration Tool (FCT)	software	– CDVI5.0, Clean Design	cdvi5.0
– Pneumatic dimensioning	14	– CPASC1	cpasc1
Soldering base, PCBC	pcbc	– JMEBH-5/2, to ISO 5599-1	553, 562
Solenoid valve		– JMEBH, to ISO 5599-1	549
– Basic valve LC	lc	– JMFH-5, Tiger 2000	tiger 2000
– Cassette valve	cm	– JMN1H-5/2, to ISO 5599-1	551
– JMFH for mounting frame 2N	m5 compact	– MEBH-5/2, to ISO 5599-1	553, 561
– JMFH for Tiger 2000	tiger 2000	– MEBH, to ISO 5599-1	549
– MFH for mounting frame 2N	m5 compact	– MFH-5, Tiger 2000	tiger 2000
– MFH for Tiger 2000	tiger 2000	– MFH, to NAMUR	namur
– MFHE	mfhe	– MGTBH, to NAMUR	namur
– MGTBH, standard valve to NAMUR	iso 15218	– MN1H-5/2, to ISO 5599-1	551
– MGXIAH, standard valve to NAMUR	iso 15218	– MN1H, to NAMUR	namur
– MHJ10	mhj9	– NVF3, to NAMUR	namur
– MHJ9	mhj9	– VMPA1	vmpa1
– Midi pneumatic	mebh	– VOFC	vofc
– MLC-8, for pneumatic feed unit BV	mlc	– VOVG	vovg
– MUFH for mounting frame 2N	m5 compact	– VSNB, to NAMUR	namur
– Supplementary range	bmch	– VSVA, to ISO 15407-1	534
– Tiger Classic	596	– VSVA, to ISO 5599-1	556
– VSVA for valve terminal VTSA	633	– VUVG-B	570
– VUVG	570	– VUVG-B-T1 for valve terminal VTUG	643
Solenoid valve, 2/2-way valve		– VUVG-L	570
– CDVI5.0, Clean Design	cdvi5.0	– VUVG-S	570
– MHA1-2/2, miniature	mh1	– VUVG-S-T1 for valve terminal VTUG	643
– MHP1-2/2, miniature	mh1	Solenoid valve, 5/3-way valve	
– MN1H-2	mn1h-2	– CDVI5.0, Clean Design	cdvi5.0
– VZWD	vzwd	– CPASC1	cpasc1
– VZWF, force pilot operated	vzwf	– MEBH-5/3, to ISO 5599-1	554, 562
– VZWM	vzwm-l	– MEBH, to ISO 5599-1	549
– VZWP, servo controlled	vzwp	– MFH-5/3, Tiger 2000	tiger 2000
Solenoid valve, 2x 3/2-way valve		– MN1H-5/3, to ISO 5599-1	551
– VSVA, to ISO 15407-1	534	– VMPA1	vmpa1
– VSVA, to ISO 5599-1	555	– VSVA, to ISO 15407-1	534
Solenoid valve, 2x2/2-way valve		– VSVA, to ISO 5599-1	557
– CPASC1	cpasc1	– VUVG-B	570
		– VUVG-B-T1 for valve terminal VTUG	643

Designation	Page/online	Designation	Page/online
– VUVG-L	570	Stopper cylinder	
– VUVG-S	570	– DFST	dst
– VUVG-S-T1 for valve terminal VTUG	643	– STA	sta
Solutions, Ready-to-install	1000	– STAF, with flange mounting	staf
Sortbox, CHB-SB	chb-sb	Sub-base, VMPAL-AP for valve terminal MPA-L	673
Spark arresting	1054	Sub-base valve, VMPA for valve terminal MPA-L	670
Special housing	1013	Suction cup	
Special oil, OFSW for MS series	891	– ESS	ess
Spindle axis		– ESV	esv
– DGE-SP with recirculating ball bearing guide	dge-sp	– VAS	vas
– DGE-SP without guide	dge-sp	– VASB	vasb
– EGC-BS-KF with recirculating ball bearing guide	324	Suction cup holder	
– EGC-HD-BS with heavy-duty guide	334	– ESH	esh
Spiral plastic tubing		Suction gripper	
– PPS	pps	– ESG	esg
– PUN-S-DUO, DUO tubing	pun-s	Supplementary range	
– PUN-SG	pun-sg	– Pneumatic valve	vl
Spiral wrap for tubing, PKB	pkb	– Solenoid valve	bmch
Stainless steel cylinder, see Standard cylinder, round cylinder		Supply cable, KPWR	kpwr
Standard cylinder		Supply plate	
– CRDNG, corrosion-resistant	crdng	– VABF for valve terminal VTSA	639
– CRDNGS, stainless steel	crdngs	– VABF-L1-10-P3A4-M5 for manifold rail for VUVG, in-line valve M5	576
– CRDSNU, round cylinder, stainless steel	crdsnu	– VABF-L1-10-P3A4-M5 for manifold rail for VUVG, sub-base valve M5	588
– DDPC, integrated displacement encoder	ddpc	– VABF-L1-10-P3A4-M7 for manifold rail for VUVG, in-line valve M7	576
– DNC-KP, with clamping unit	dnc-kp	– VABF-L1-10-P3A4-M7 for manifold rail for VUVG, sub-base valve M7	588
– DNC-V, cylinder/valve combination	dnc-v	– VABF-L1-14-P3A4-G18 for manifold rail for VUVG, in-line valve G1/8	582
– DNCI, with displacement encoder	dnci	– VABF-L1-14-P3A4-G18 for manifold rail, sub-base valve VUVG, G1/8	594
– DNG, to ISO 15552	dng	Switch lug	
– DNGZK, to ISO 15552	dngzk	– EAPM for mini slide EGSL	369
– DNGZS, to ISO 15552	dngzs	– EAPM for toothed belt axis ELGA-TB	379
Standard cylinder to ISO 15552 (ISO 6431 and VDMA 24562)		– EAPM for toothed belt axis ELGR	387
– DNC, double-acting	63	– SF-EGC-1 for linear drive DGC-HD with heavy-duty guide	175
– DSBC, double-acting	35	– SF-EGC-1 for spindle axis EGC-BS	328
– DSBF-C, double-acting, Clean Design	56	– SF-EGC-1 for spindle axis EGC-HD-BS	338
– DSBG, double-acting	46	– SF-EGC-1 for toothed belt axis EGC-HD-TB	358
Standard cylinder to ISO 6432		– SF-EGC-1 for toothed belt axis EGC-TB	348
– DSN, double-acting	71	– SF-EGC-2 for linear drive DGC-HD with heavy-duty guide	175
– DSNU-KP, double-acting, with clamping cartridge	78	– SF-EGC-2 for spindle axis EGC-BS	328
– DSNU, double-acting	71	– SF-EGC-2 for spindle axis EGC-HD-BS	338
– DSNUP, double-acting	71, 77	– SF-EGC-2 for toothed belt axis EGC-HD-TB	358
– ESN, single-acting	71	– SF-EGC-2 for toothed belt axis EGC-TB	348
– ESNU, single-acting	71	Swivel clamp, CLR, linear	clr
Standard valve		Swivel flange	
– VDI/VDE 3845	namur	– DAMS for electric cylinder ESBF	310
– VSVA-T1, for valve terminal VTSA	vsva	– SNC for electric cylinder DNCE	310, 318
Standard valve with round plug, VSCS-B-M32...R3	iso 15218	– SNC for short-stroke cylinder ADVC/AEVC	131
Standard valve with square plug, type A, MDH-3/2...EX	iso 15218	– SNC for standard cylinder DSBG to ISO 15552	41, 50
Standard valve with square plug, type C, VSCS-B-M32...C1	iso 15218	– SNC for standard cylinder to ISO 15552	67
Standard valves		– SNCB for compact cylinder to ISO 21287	114
– ISO 15407-1	533	– SNCB for electric cylinder DNCE	310, 318
– ISO 5599-1	549	– SNCB for electric cylinder EPCO	302
Standards	1032	– SNCB for short-stroke cylinder ADVC/AEVC	132
Stem actuated micro valve		– SNCB for standard cylinder DSBG to ISO 15552	41, 50
– S-3-PK, 3/2-way valve	s-3-pk	– SNCB for standard cylinder to ISO 15552	67
– SO-3-PK, 3/2-way valve	so-3-pk	– SNCB-...R3 for standard cylinder DSBF-C to ISO 15552	60
Stem actuated valve		– SNCL for compact cylinder to ISO 21287	114
– V, 3/2-way valve	v-3	– SNCL for electric cylinder DNCE	310, 318
– V, 5/2-way valve	v-5	– SNCL for electric cylinder EPCO	302
– V/O, 3/2-way valve	v/o	– SNCL for short-stroke cylinder ADVC/AEVC	132
– VMEM, 3/2-way valve	vmem	– SNCL for standard cylinder DSBG to ISO 15552	41, 50
– VMEM, 5/2-way valve	vmem	– SNCL for standard cylinder to ISO 15552	67
– VO, 3/2-way valve	vo-3	– SNCS for compact cylinder to ISO 21287	114
– VOS, 3/2-way valve	vos	– SNCS for electric cylinder DNCE	310, 318
– VS, 3/2-way valve	vs-3	– SNCS for electric cylinder EPCO	302
– VS, 4/2-way valve	vs-4	– SNCS for short-stroke cylinder ADVC/AEVC	132
Stepper motor		– SNCS for standard cylinder DSBG to ISO 15552	41, 50
– EMMS-ST	439	– SNCS for standard cylinder to ISO 15552	67
– MTRE-ST	mtre	Swivel lever valve	
Stop kit, KSM for swivel module DSM	198	– RW, 3/2-way valve	rw-3

Designation	Page/online	Designation	Page/online
– RW/O, 3/2-way valve	rw/o-3	– CRZNG for standard cylinder DSBF-C to ISO 15552	60
Swivel module		– ZNCF for compact cylinder to ISO 21287	114
– DSM	193	– ZNCF for electric cylinder DNCE	310, 318
– DSM-B	205	– ZNCF for electric cylinder EPCO	302
– DSMI, with displacement encoder	dsmi	– ZNCF for short-stroke cylinder ADVC/AEVC	131
Swivel module with tandem rotary vanes, DSM-T-B	205	– ZNCF for standard cylinder DSBG to ISO 15552	41, 50
Swivel mounting		– ZNCF for standard cylinder to ISO 15552	67
– EAHS for electric cylinder EPCO	302	Trunnion mounting kit	
– SBN for round cylinder DSNU/ESNU	99	– DAMT for electric cylinder DNCE	318
– SBN for standard cylinder to ISO 6432	85	– DAMT for standard cylinder DSBC to ISO 15552	42
– WBN for round cylinder DSNU/ESNU	99	– DAMT for standard cylinder to ISO 15552	68
– WBN for standard cylinder to ISO 6432	85	– ZNCM for electric cylinder DNCE	311
Swivel/gripper unit, HGDS	hgds	Trunnion support	
Swivel/linear drive unit, DSL-B	dsl	– CRLNZG for standard cylinder DSBF-C to ISO 15552	60
		– CRLNZG, stainless steel	crlnzg
T		– LNZG	lnzg
T-adapter, FB-TA	fb-ta	– LNZG for compact cylinder to ISO 21287	114
T-fitting, TJK	tjk	– LNZG for electric cylinder DNCE	310, 318
Tandem cylinder, DNCT, standard hole pattern	dnct	– LNZG for electric cylinder EPCO	302
Temperature sensor, CPX-W-PT1000 for terminal CPX	717	– LNZG for short-stroke cylinder ADVC/AEVC	131
Terminal		– LNZG for standard cylinder DSBG to ISO 15552	41, 50
– See Pneumatic terminal		– LNZG for standard cylinder to ISO 15552	67
– CPX	cpx	Tubing, see Plastic tubing	
Terminal CPX	677	Tubing cutter, PAN	zds
Terminal CPX-P	968	Tubing strap, PB	pb
Terminal markings, Valves	1039	Tubing support	
Terminal socket, KDV	kdv	– NPAW	npaw
Thread sealing tape, GWB	938	– PKS	pkc
Threaded fitting, NPFB	npfb	Twin-piston cylinder	
Threaded pin		– DPZ, with guide	dpz
– CRGBS, stainless steel	crgbs	– DPZJ, with guide, with two yoke plates	dpzj
– GBS	gbs	Twin-piston rotary drive	
Three-dimensional gantry, DHSR	dhsr	– DRQD, see Semi-rotary drives	
Three-point gripper		– DRQD-B, see Semi-rotary drives	
– DHDS	488		
– HGDD	hgdd	U	
– HGDT	hgdt	User documentation	
Through-beam sensor, see Fork light barriers SOOF		– P.BE-CPX for terminal CPX	718
Tie rod		– P.BE-CPX for terminal CPX-P	987
– CPX-ZA for terminal CPX	712	– P.BE-MPA-L for valve terminal MPA-L	676
– VMPAL-ZA for valve terminal MPA-L	672		
Tiger 2000, Solenoid valve	tiger 2000	V	
Time delay insert, MFZ	mfz	Supply plate, VABF-L1 for valve terminal VTUG	659
Time delay valve		Vacuum filter, VAF	vaf
– VZ for mounting frame 2N	m5 compact	Vacuum gauge	
– VZA	vza	– FVAM	fvam
– VZB	vza	– VAM	vam
– VZO for mounting frame 2N	m5 compact	Vacuum gauge to EN 837-1	
– VZOA	vza	– FVAM	fvam
– VZOB	vza	– VAM	vam
Timer, PZVT	pzvt	Vacuum gauge to EN 837-1, with red-green range, VAM	vam
Toggle lever valve		Vacuum generator	
– H, 5/3-way valve	h-5/3	– CPV10-M1H, for valve terminal CPV	cpv10-m1h
– KH/O, 3/2-way valve	kh/o	– CPV14-M1H, for valve terminal CPV	cpv14-m1h
– KH/O, 3/2-way valve	kh/o	– CPV18-M1H, for valve terminal CPV	cpv14-m1h
Toothed belt axis		– OVEM, metric	ovem
– DGE-ZR without guide	dge-zr	– VAD	vad
– DGE-ZR-HD with heavy-duty guide, recirculating ball bearing guide	dge-zr	– VAD-M	vad-m
– DGE-ZR-KF with recirculating ball bearing guide	dge-zr	– VAD-M-I	vad-m
– DGE-ZR-RF with roller bearing guide	dge-zr	– VADM	vadm
– EGC-HD-TB with heavy-duty guide	354	– VADMI	vadmi
– EGC-TB-KF with recirculating ball bearing guide	344	– VAK	vak
– ELGA-TB-RF	elga	– VN, electro-pneumatic	vn
– ELGA-TB	375	– VN, pneumatic	vn
– ELGG	elgg	Vacuum generator cartridge, VN	vn
– ELGR	384	Vacuum security valve, ISV	isv
Tripod		Valve terminal	
– EXPT, tripod	expt	– CDVI	cdvi
Trunnion flange		– CPA-SC, Smart Cubic	cpa-sc

Designation	Page/online	Designation	Page/online
- CPV-SC, Smart Cubic	cpv-sc		
- CPV, Compact Performance	cpv		
- MH1	mh1		
- MPA-F	mpa-f		
- MPA-L	661		
- Type 32 MPA	mpa-s		
- VTIA	vtia		
- VTOC	vtoc		
- VTSA	622		
- VTSA-F	vtsa-f		
- VTUB	vtub		
- VTUB-12	vtub-12		
- VTUG	643		
Valve terminal CPV, Vacuum generator for valve terminal CPV, see Vacuum generator			
Vertical pressure shut-off plate, VABF for valve terminal VTSA	638		
Vertical supply plate, VABF for valve terminal VTSA	638		
Vision system, SBOA-M-SYSTAINER	sbox		
W			
Water separator, MS4/MS6/MS12-LWS, MS series	ms6-lws		
Whisker valve			
- FVS, 3/2-way valve	fvs		
- FVSO, 3/2-way valve	fvso		
Y			
Y-distributor, MKY, for protective conduits	mky		

.com.ar
.at
.com.au
.be
.bg
.com.br
.by
.ca
.ch
.cl
.cn
.co
.cz
.de
.dk
.ee
.es
.fi
.fr
.gr
.hk
.hr
.hu
.co.id
.ie
.co.il
.in
.ir
.it
.jp
.kr
.lt
.lv
.mx

Festo worldwide
www.festo.com

.com.my
.nl
.no
.co.nz
.pe
.ph
.pl
.pt
.ro
.ru
.se
.sg
.si
.sk
.co.th
.com.tr
.tw
.ua
.co.uk
.us
.co.ve
.vn
.co.za