

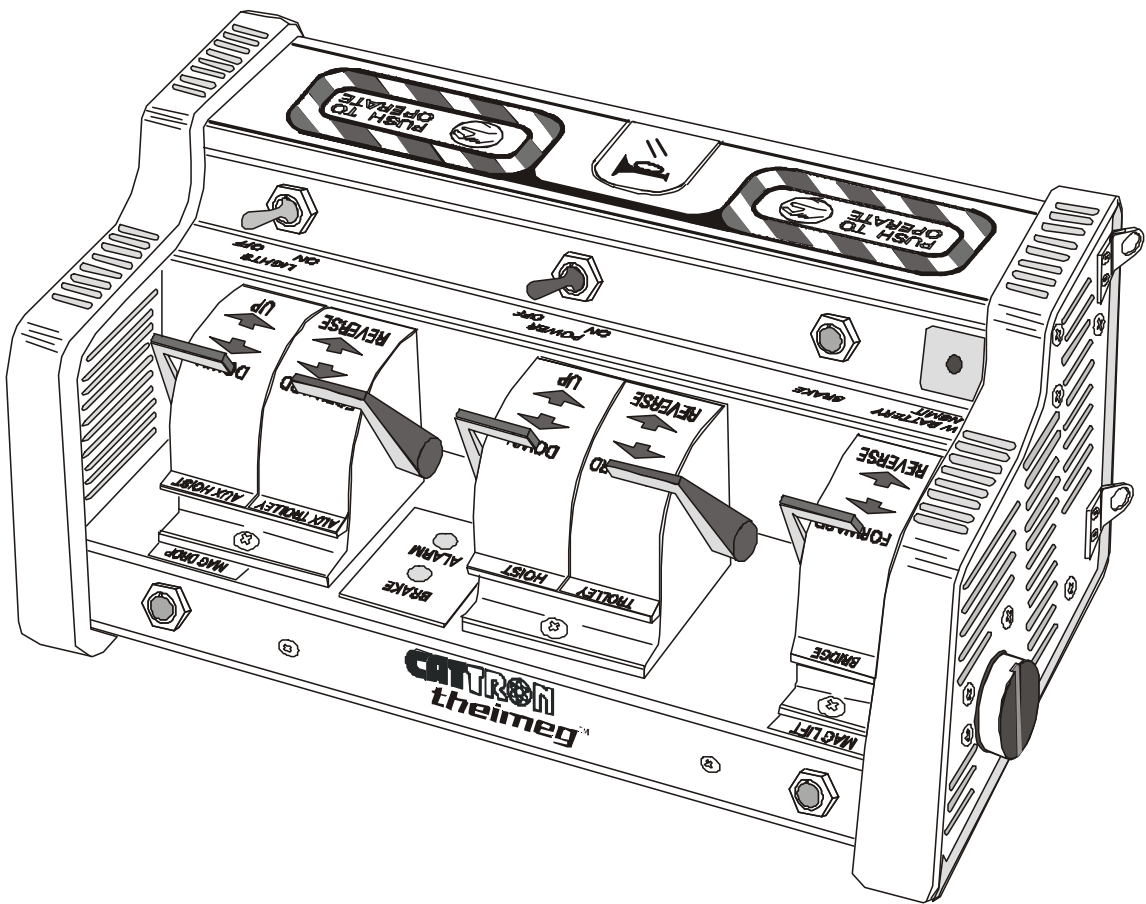

PADDLE CONTROLLER

OPERATION & MAINTENANCE INSTRUCTIONS



CUSTOMER: _____
MODEL NUMBER: _____
SERIAL NUMBER: _____
FREQUENCY ASSIGNMENT: _____
ADDRESS ASSIGNMENT: _____
MANUAL P/N: 68C-Paddle Rev. 006, 03/2007



FCC and IC Statements

FCC and IC labeling can be found inside the user accessible lid of the battery compartment where it is protected from damage.

FCC Warning Statements

Changes or modifications not expressly approved by the party responsible for compliance could void the user's authority to operate the equipment

For Low Power License Exempt Units

FCC Warning Statements

Note: This equipment has been tested and found to comply with the limits for a Class A digital device, pursuant to part 15 of the FCC Rules. These limits are designed to provide reasonable protection against harmful interference when the equipment is operated in a commercial environment. This equipment generates, uses, and can radiate radio frequency energy and, if not installed and used in accordance with the instruction manual, may cause harmful interference to radio communications. Operation of this equipment in a residential area is likely to cause harmful interference in which case the user will be required to correct the interference at his own expense.

This device complies with Part 15 of the FCC rules. Operation is subject to the following two conditions: (1) This device may not cause harmful interference, and (2) This device must accept any interference received, including interference that may cause undesired operation.

IC Warning Statements

This device complies with Industry Canada license-exempt RSS standard(s). Operation is subject to the following two conditions: (1) this device may not cause interference, and (2) this device must accept any interference, including interference that may cause undesired operation of the device.

Le présent appareil est conforme aux CNR d'Industrie Canada applicables aux appareils radio exempts de licence. L'exploitation est autorisée aux deux conditions suivantes : (1) l'appareil ne doit pas produire de brouillage, et (2) l'utilisateur de l'appareil doit accepter tout brouillage radioélectrique subi, même si le brouillage est susceptible d'en compromettre le fonctionnement

This Class A digital apparatus complies with Canadian ICES-003.
Cet appareil numérique de la classe A est conforme à la norme NMB-003 du Canada



IMPORTANT NOTICES

Your new paddle controller has been pre-configured to operate on a specific frequency before leaving our factory which cannot be changed by yourselves. We have assigned this frequency based upon our existing records of control equipment previously supplied to yourselves. However, we strongly recommend you satisfy yourselves that the frequency of your paddle controller does not match that of any other radio remote control system located at, or around, your operating facility.

WARNING:



CATTRON-THEIMEG™ MAKES EVERY EFFORT TO ENSURE THE ADDRESS ASSIGNED TO YOUR NEW CONTROL SYSTEM IS NOT DUPLICATED BASED UPON RECORDS WHICH INDICATE THE ADDRESSES OF ALL PAST PORTABLE RADIO REMOTE CONTROL (PRRC) SYSTEMS AS SHIPPED FROM OUR FACILITY TO YOURS.

THEREFORE IT SHOULD BE FULLY UNDERSTOOD THAT WHEN A PRRC SYSTEM HAS LEFT OUR FACTORY, CATTRON-THEIMEG™ HAS NO CONTROL OF THE ADDRESS ASSIGNMENTS OF ANY OTHER PRRC SYSTEM(S) THAT MAY BE IN OPERATION IN CLOSE PROXIMITY WITHIN YOUR OPERATING AREA.

CONSEQUENTLY, AND PURSUANT TO THE ABOVE STATEMENT, CATTRON-THEIMEG™ SHALL NOT BE HELD LIABLE FOR PERSONAL INJURY, DEATH, EQUIPMENT OR PROPERTY DAMAGE ARISING FROM DUPLICATED ADDRESSES OF RADIO CONTROL SYSTEMS.

OPERATION & MAINTENANCE INSTRUCTIONS

IMPORTANT NOTICES, continued.

Your Remote Control System may include an optional 'Reset' function that must be activated from the remote controller before motion control outputs are enabled on the controlled machine. You are advised to review the customized drawing package provided with your Portable Remote Control (PRC) system to see if this optional safety feature applies to your PRC system.

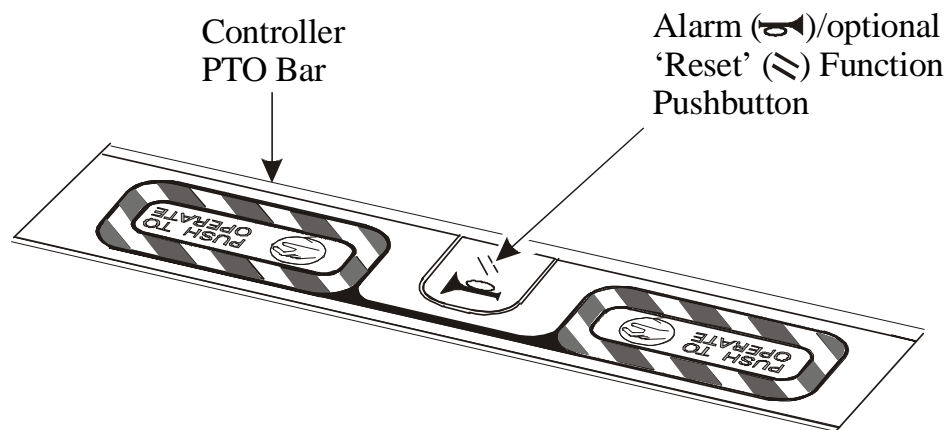

When this 'Reset' function applies to your PRC system, the momentary Alarm/Reset pushbutton located in the center of the controller's PTO bar must be depressed immediately after the controller has completed its Power On Self Test, and before holding the PTO bar down to activate a motion control function. This will sound the system horn (when connected) and reset the Main Equipment Power Contactor.

This equipment is firmware based, including encoder, decoder, transmitter, and receiver. Any duplication of operating firmware without written consent of CATTRON-THEIMEG[™] is prohibited. All firmware, product listings, assembly files, and this manual are protected by U.S. Copyright Laws.

As part of our continuous improvement policy, CATTRON-THEIMEG[™] reserves the right to change specifications without notice.



List of Technical Abbreviations

The following abbreviations (acronyms) are frequently used in CATTRON-THEIMEG™ Radio Remote Control Technology and may be used in this manual:

AC	<u>A</u> lternating <u>C</u> urrent
ASO	<u>A</u> utomatic <u>S</u> afety <u>O</u> verride
BCH	<u>B</u> ose- <u>C</u> haudhuri- <u>H</u> ocquenghem (data error detection routines)
CMOS	<u>C</u> omplimentary <u>M</u> etal <u>O</u> xide <u>S</u> emiconductor
CS	<u>C</u> rane <u>S</u> pecific
DC	<u>D</u> irect <u>C</u> urrent
DOC	<u>D</u> epartment of <u>C</u> ommunication
DP	<u>D</u> ual <u>P</u> ressure
EDP	<u>E</u> lectronic <u>D</u> ata <u>P</u> rocessing
EEPROM	<u>E</u> lectrically <u>E</u> rasable <u>P</u> rogrammable <u>R</u> ead <u>O</u> nly <u>M</u> emory
EMI	<u>E</u> lectro- <u>M</u> agnetic <u>I</u> nterference
EOT	<u>E</u> lectrical <u>O</u> verhead <u>T</u> raveling
EPROM	<u>E</u> rasable <u>P</u> rogrammable <u>R</u> ead <u>O</u> nly <u>M</u> emory
FCC	<u>F</u> ederal <u>C</u> ommunications <u>C</u> ommission
GND	<u>G</u> round
I/O	<u>I</u> nput/ <u>O</u> utput
LCD	<u>L</u> iquid <u>C</u> rystal <u>D</u> isplay

LED	<u>L</u> ight <u>E</u> mitting <u>D</u> iode
MK	<u>M</u> etal <u>K</u> eypad
ML	<u>M</u> ainline
NEMA	<u>N</u> ational <u>E</u> lectrical <u>M</u> anufacturer's <u>A</u> ssociation
Ni-Cad	<u>N</u> ickel <u>C</u> admium
OPR	<u>O</u> perate
PRC	<u>P</u> ortable <u>R</u> emote <u>C</u> ontrol
PTO	<u>P</u> ush- <u>t</u> o- <u>O</u> perate
RF	<u>R</u> adio <u>F</u> requency
RFI	<u>R</u> adio <u>F</u> requency <u>I</u> nterference
RST	<u>R</u> eset <u>R</u> elay
SP	<u>S</u> ingle <u>P</u> ressure
SYNC	<u>S</u> ynchronization
TS	<u>T</u> ransfer <u>S</u> witch
VAC	<u>V</u> olts <u>A</u> lternating <u>C</u> urrent
VDC	<u>V</u> olts <u>D</u> irect <u>C</u> urrent
VFD	<u>V</u> ariable <u>F</u> requency <u>D</u> rive



Introduction

How to use this Manual.

This manual contains generic operation and maintenance procedures applicable to the entire series of CATTRON-THEIMEG™ Radio Remote Paddle Controllers.

Because no two Paddle Controllers or Portable Remote Control (PRC) applications are exactly the same, a General Operating Procedure is included in Section 3. This procedure is followed by Operator Instructions for the two most popular control applications: (1) Cranes, and (2) Locomotives. By selecting the application (1) or (2) closest to your PRC system, you should be able to familiarize yourself with the basic operating procedures and control functions that apply to your system.

We emphasize that safety considerations are paramount when using portable remote controllers. Accordingly, Section 2 should be read in its entirety. Also, for your consideration and possible adoption, Recommended Safety Rules for Remote Controlled Cranes, and Recommended Safety Rules for Radio Remote Controlled Locomotives are provided as an addendum at the end of this manual.

Safety Summary

WARNING and **CAUTION** statements have been strategically placed throughout all text prior to operating or maintenance procedures, practices or conditions considered essential to the protection of personnel (**WARNING**), or equipment and property (**CAUTION**). A **WARNING** and **CAUTION** will apply each time the related step is repeated. Before starting any task, the **WARNINGS** or **CAUTIONS** included in the text for the task shall be reviewed and understood. All **WARNINGS** and **CAUTIONS** appearing in this manual are included below.

WARNINGS.



WARNINGS:

WITH THE EXCEPTION OF LOCOMOTIVES, ALL EQUIPMENT MUST HAVE A MAINLINE (ML) CONTACTOR INSTALLED AND ALL TRACKED EQUIPMENT (i.e. CRANES) HAVE A BRAKE INSTALLED.

THE REMOTE CONTROL OPERATE (OPR) RELAY MUST BE CONNECTED TO THE MAINLINE SO THAT STOP COMMANDS OR FAULT CONDITIONS MONITORED BY AUTOMATIC SAFETY OVERRIDE (ASO) CIRCUITRY WILL DE-ENERGIZE THE MAINLINE CONTACTOR AND SET THE EQUIPMENT BRAKE.

FAILURE TO COMPLY WITH THE ABOVE WARNINGS MAY RESULT IN SERIOUS INJURY OR DEATH TO PERSONNEL AND DAMAGE TO EQUIPMENT.



WARNING:

MORE THAN ONE REMOTE CONTROL SYSTEM MAY BE USED AT, AROUND, OR NEARBY YOUR OPERATING FACILITY. THEREFORE, YOU MUST INSURE THE ADDRESS CODE AND FREQUENCY OF YOUR PADDLE CONTROLLER EXACTLY MATCHES THE ADDRESS CODE AND FREQUENCY OF THE DESIRED EQUIPMENT TO BE OPERATED.

FAILURE TO COMPLY WITH THE ABOVE WARNING MAY RESULT IN THE UNDESIRE OPERATION OF OTHER EQUIPMENT WHICH, IN TURN, COULD RESULT IN SERIOUS INJURY OR DEATH TO PERSONNEL AND DAMAGE TO EQUIPMENT.



WARNING:

NEVER DISABLE THE PUSH TO OPERATE (PTO) BAR SWITCH ON YOUR REMOTE CONTROLLER. FAILURE TO COMPLY WITH THIS WARNING MAY RESULT IN DAMAGE TO EQUIPMENT, SERIOUS INJURY, OR DEATH.

WARNINGS, continued.



WARNING:

ON CAB AND REMOTE OPERATED CRANES OR CARRIERS AN AUDIBLE OR VISUAL WARNING MEANS SHALL BE PROVIDED. IN ADDITION, ALL EQUIPMENT SHALL HAVE AUDIO OR VISUAL ALARM INDICATIONS MEETING GOVERNMENTAL REQUIREMENTS. FAILURE TO IMPLEMENT THIS WARNING MAY RESULT IN SERIOUS INJURY OR DEATH TO PERSONNEL AND DAMAGE TO EQUIPMENT.



WARNINGS:

UNCODED ADDRESS PLUG(S) SHALL BE PROGRAMMED WITH THE SAME ADDRESS CODE AS SET IN THE TARGET RECEIVER/DECODER. IT SHOULD BE FULLY UNDERSTOOD THAT CATTRON-THEIMEGTM SHALL NOT BE HELD LIABLE FOR PERSONAL INJURY, DEATH, EQUIPMENT OR PROPERTY DAMAGE ARISING FROM DUPLICATED, INCORRECTLY PROGRAMMED OR INCORRECT CODE PLUG USAGE.

IT IS YOUR RESPONSIBILITY TO ESTABLISH A PROCEDURE THAT INSURES ONLY THE CODE PLUG CONFIGURED FOR A PARTICULAR ADDRESS IS INSTALLED IN EQUIPMENT DESIGNED TO OPERATE ON THE SAME ADDRESS. NEVER PUT MORE THAN ONE CONTROLLER INTO OPERATION ON THE SAME ADDRESS AT ANY GIVEN TIME. CATTRON-THEIMEGTM STRONGLY ADVISES YOU TO IMPLEMENT AND REGULARLY UPDATE A REGISTER OF INDIVIDUAL ADDRESSES AND OPERATING FREQUENCIES ASSIGNED TO EACH PORTABLE RADIO REMOTE CONTROL (PRRC) SYSTEM LOCATED AT YOUR OPERATING FACILITY. IN ADDITION, ANY SPARE CODE PLUGS, OR CODE PLUGS INSTALLED IN EQUIPMENT THAT ARE CONFIGURED FOR THE SAME ADDRESS OF EQUIPMENT THAT IS IN SERVICE, MUST BE HELD UNDER LOCK AND KEY BY A DESIGNATED SUPERVISOR.

FAILURE TO COMPLY WITH THESE WARNINGS MAY RESULT IN OPERATION OF UNDESIRED EQUIPMENT WHICH IN TURN COULD RESULT IN SERIOUS INJURY OR DEATH TO PERSONNEL AND DAMAGE TO EQUIPMENT.

WARNINGS, continued.



WARNINGS:

ALL TRACKED EQUIPMENT (i.e. LOCOMOTIVES) MUST HAVE A BRAKE INSTALLED.

THE REMOTE CONTROL OPERATE (OPR) RELAY MUST BE CONFIGURED SO THAT STOP COMMANDS OR FAULT CONDITIONS MONITORED BY AUTOMATIC SAFETY OVERRIDE (ASO) CIRCUITRY WILL SET THE THROTTLE TO IDLE, DISCONNECT THE GENERATOR FIELD, AND SET THE INDEPENDENT BRAKE.

FAILURE TO COMPLY WITH THE ABOVE WARNINGS MAY RESULT IN SERIOUS INJURY OR DEATH TO PERSONNEL AND DAMAGE TO EQUIPMENT.



WARNING:

AFTER CHANGING AN ADDRESS OR FREQUENCY SELECTOR SWITCH, YOU MUST, IN THE FIRST INSTANCE, INSURE THE TARGETED MACHINE IS UNDER REMOTE CONTROL BEFORE OPERATING ANY MOTION FUNCTION SWITCH. THIS MAY BE ACCOMPLISHED BY OPERATING A NON MOTION FUNCTION SWITCH ON THE REMOTE CONTROLLER SUCH AS A HORN OR LIGHT.

FAILURE TO COMPLY WITH THE ABOVE WARNING MAY RESULT IN THE UNDESIRE OPERATION OF OTHER EQUIPMENT WHICH, IN TURN, COULD RESULT IN SERIOUS INJURY OR DEATH TO PERSONNEL AND DAMAGE TO EQUIPMENT.



WARNING:

ELECTRICAL POWER TO THE TARGET CONTROLLED EQUIPMENT MUST BE COMPLETELY ISOLATED TO PREVENT OPERATION UNDER REMOTE CONTROL IN THE SWITCH DIAGNOSTIC MODE.

FAILURE TO COMPLY WITH THE ABOVE WARNING MAY RESULT IN THE UNDESIRE OPERATION OF EQUIPMENT WHICH, IN TURN, COULD RESULT IN SERIOUS INJURY OR DEATH TO PERSONNEL AND DAMAGE TO EQUIPMENT.

WARNINGS, continued.



WARNING:

DUE TO FCC PART 15 AND DOC RSS-210 RADIO TRANSMIT REGULATIONS, THE OPR OUTPUT TO WHICH YOUR CONTROLLED EQUIPMENT'S MAINLINE CONTACTOR IS CONNECTED WILL REMAIN ENERGIZED FOR TEN MINUTES AFTER THE CONTROLLER POWER IS SET TO 'OFF', OR FOR TEN MINUTES AFTER THE LAST TIME A FUNCTION SWITCH IS ACTIVATED. CONSEQUENTLY, SPECIAL CARE MUST BE TAKEN IF THE CRANE OR TRACKED MACHINE IS EQUIPPED WITH A PARKING BRAKE THAT IS CONFIGURED TO ENGAGE WHEN THE MAINLINE CONTACTOR DE-ENERGIZES.

TO PREVENT A POTENTIALLY HAZARDOUS SITUATION, YOU SHOULD IMMEDIATELY SELECT THE RED 'STOP' FUNCTION ON YOUR REMOTE CONTROLLER AFTER COMPLETION OF OPERATIONS. SUCH ACTION WILL INSURE THE PARKING BRAKE (IF EQUIPPED AND CONFIGURED AS ABOVE) IS SET, PREVENTING UNINTENTIONAL MOVEMENT OF THE CRANE OR TRACKED MACHINE.

FAILURE TO COMPLY WITH THIS WARNING MAY RESULT IN SERIOUS INJURY OR DEATH TO PERSONNEL AND DAMAGE TO EQUIPMENT.

CAUTIONS.



CAUTIONS:

- (1) CATTRON-THEIMEG™ Battery Conditioners are designed for use with CATTRON-THEIMEG™ Ni-Cad Battery Packs only.**
- (2) Battery Packs must be removed or disconnected from Battery Conditioners within 48-hours of achieving the fully charged state.**

Failure to comply with these Cautions may result in equipment and/or battery damage and will void our warranty.

NOTE.



Important Safety Note:

When using the controller, operators are instructed to wear a factory approved carrying harness with the controller attached at all times. If a controller must be left unattended, the STOP switch (when installed to the controller) should be depressed and the controller's power ON/OFF switch set to 'OFF'. If the power ON/OFF switch is a key switch, the key should also be removed to prevent unauthorized use of the controller.



Safety Summary, continued.

GENERAL.

The following are general safety precautions that are not related to any specific procedure and therefore do not appear elsewhere in this manual. These are general safety precautions and instructions that people must understand and apply during many phases of operation and maintenance to ensure personal safety and health and the protection of your company property.

KEEP AWAY FROM LIVE CIRCUITS. Maintenance personnel must observe all safety requirements at all times. Do not replace components or make adjustments inside the equipment with the electrical supply turned on. Under certain conditions, danger may exist even when the power control is in the off position due to charges retained by capacitors. To avoid injuries, always remove power, discharge and ground a circuit before touching it. Adhere to all lock out/tag requirements.

DO NOT SERVICE OR ADJUST ALONE. Whenever possible, do not attempt internal service or adjustment of equipment unless another person capable of rendering aid and resuscitation is present.

FINGER RINGS/JEWELRY. Finger rings have caused many serious injuries. Remove rings, watches and other metallic objects which may cause shock or burn hazards.

SOLDERING/DE-SOLDERING. Avoid breathing fumes generated by soldering/de-soldering. Perform all operations in a ventilated area. Eye protection is required.

CLEANING SOLVENTS. Some cleaners and solvents have adverse effects on skin, eyes, respiratory tract and internal organs. These adverse effects range from discomfort to serious injury and death, depending on the material and degree of exposure. Observe manufacturers' warning labels and contact your immediate supervisor if in any doubt.

Remember.... the person now reading these instructions is primarily responsible for his or her own health and safety.



This page intentionally left blank



Table of Contents

Front Matter:

FCC and IC Warnings.....	i
Important Notices	ii-iii
List of Technical Abbreviations	i v
How to use this Manual	v
Safety Summary warnings and cautions	vi-x

Section 1 – Product Data and Specifications:

Introduction	1-1
Notable Performance and Safety features	1-2
Frequently asked questions	1-3
Standard Specifications	1-5
Overview of CATTRON-THEIMEG™ Remote Control Systems	1-7

Section 2 – Safety Information:

Safety Considerations	2-1
Safety and Security Features	2-1
Typical Method of Operation incorporating	2-2
Safety & Security Features	
Radio Control Operator’s Duties – General Equipment	2-4
Radio Control Operator’s Duties – E.O.T. Crane	2-8
Radio Control Operator’s Duties – Locomotive	2-12

Section 3 – Operating Instructions:

Controls and Indicators	3-1
General Operating Procedure	3-5
Typical Crane Control Functions	3-10
Typical Locomotive Control Functions	3-13
Switch Diagnostic Mode	3-17



Section 3 – Operating Instructions, continued:

Battery Packs and Battery Pack Charging	3-18
Battery Pack Replacement	3-18
Battery Pack Conditioning/Charging – Ni-Cad Battery packs only	3-20
Pre-Programmed Frequency Selection	3-22
Pre-Programmed Option Selection	3-25

Section 4 – Maintenance Instructions:

CATTRON-THEIMEG™ Maintenance Philosophy	4-1
Preventive Maintenance	4-1
Troubleshooting	4-2
Troubleshooting Guide	4-3
Corrective Maintenance	4-4
Functional Check	4-4
Replacement Items	4-4
Battery Pack	4-4
Address Code Plug	4-5
Side Lever (optional item)	4-9
External Antenna (optional item)	4-9

Section 5 – Replacement Items and Accessories:

Replacement Items	5-1
Consumable Items and Optional Accessories	5-5

Index.

Appendices:

- 1. RECOMMENDED SAFETY RULES FOR PORTABLE REMOTE CONTROLLED (PRC) CRANES.**
- 2. RECOMMENDED SAFETY RULES FOR PORTABLE RADIO REMOTE CONTROLLED (PRRC) LOCOMOTIVES.**



Section 1 – Product Data & Specifications

Introduction.

The CATTRON-THEIMEG™ Paddle Controller has a unique shape and style that provide the equipment operator with a controller that is extremely durable, convenient, and easy to operate. Designed specifically for heavy duty in harsh working environments, the controller is ideally suitable for both indoor and outdoor remote control applications within the steel, glass, automotive, shipping, mining, distribution, and railroad industries. It can be used with all CATTRON-THEIMEG™ AT Series or MP Series receiver/decoder units as well as being used with existing CATTRON-THEIMEG™ PRC systems as either a replacement or spare controller.

Your paddle controller is designed to duplicate the operating characteristics of the controls most commonly found on the controlled machine, therefore the change from manual to radio remote control is easily learned by the operator.

The CATTRON-THEIMEG™ paddle controller employs advanced micro-computer electronics and utilizes surface mount technology. A highly advanced encoder circuit board is built using industrial grade components and incorporates a powerful microcomputer that uses sophisticated operating software. The main housing that surrounds and protects the electronic circuitry is made of thick walled, extruded aluminum with a protective exterior coating. The ends of the housing are rubber-coated plates that make shock absorbing end ‘bumpers’ and switch/lever guards. Only the highest quality industrial grade and ‘mil-spec’ switches whose reliability and construction have been field-tested and proven under extreme conditions are used in your paddle controller. Total water and dust sealing makes these switches suitable for indoor and outdoor operation.

CATTRON-THEIMEG™ paddle controllers have room for up to six paddles and can be customized with additional pushbuttons and toggle switches. In addition, all functions are identified by durable custom engraved nameplates.

A variety of synthesized and crystal-controlled RF transmitter configurations can be provided with this controller, allowing operation on licensed and non-licensed VHF and UHF radio channels. In addition, all CATTRON-THEIMEG™ paddle controllers meet the FCC's requirements regarding narrow band and 12.5 kHz bandwidths.



Notable Performance and Safety Features.

POWER ON SELF TEST (POST) DIAGNOSTICS - When the operator first turns the power switch on, a sophisticated self-test routine tests the microcomputer and all function switch inputs to detect unwanted commands in the system. All lever style switches are tested for neutral at this time. A small speaker beeps twice when the test has been completed satisfactorily.

TRANSMIT/BATTERY CHARGE INDICATOR - The low battery detection circuit is a two stage design. With a good battery, this indicator light flashes green for each burst of transmitted data. If the battery voltage drops below the normal level, this LED flashes red during each transmission. A beeping sound every 10 seconds alerts the operator. When this happens, the battery has approximately one hour of operating time remaining. The controller stops transmitting before the voltage drops so low that erratic operation could occur.

BATTERY SAVER - If the controller has not been operated for 15 minutes, a battery management system detects this inactivity and puts the controller into a 'deep sleep' mode. To reset the controller, the POWER ON/OFF SWITCH must be set to 'OFF', and then set to 'ON' again.

BATTERY PACK OPTIONS - Alkaline (disposable) & Ni-Cad (rechargeable) battery packs are available from CATTRON-THEIMEG™. Whether you choose disposable or rechargeable battery packs, changing the battery pack is easy - simply unlatch and open the gasketed battery door, drop the battery pack in place and close and latch the battery door. There are no wires or connectors to insert into the battery pack, which improves long-term reliability of this unit.

RUGGED HOUSING - The housing that surrounds and protects the electronic circuitry is a thick-walled extruded aluminum, which has a hard epoxy powder coated exterior. The ends of the housing are rubber coated plates that make shock absorbing end 'bumpers'.

DURABLE/OUTDOOR OPERATION - All switches are extremely long life units that are sealed, providing water and dust protection. All modules and sub-components are gasketed, making your controller suitable for outdoor operation in rain and snow.

LEVER AND SWITCH PLACEMENT - Each layout is customized according to user needs. The switch levers are placed far enough apart to accommodate operators who wear heavy gloves.

SAFETY BAR - A long safety bar is provided to function as an enable device to all motion control switches. It is a large full-length switch that is easily and naturally activated by a convenient and comfortable part of the operator's hand any time he or she activates a motion switch. This push-to-operate (PTO) safety bar electronically disconnects all motion switches when it is released, thus stopping motion commands from these switches. This feature is programmable as some applications may have lever switches removed from control of the PTO bar. An example of this would be some locomotive braking functions.

ALARM/RESET FUNCTION (optional) - Your remote controller may incorporate this additional safety function connected to the momentary pushbutton located in the center of the PTO Safety Bar. Check the system drawings provided with your remote control system to see if this optional feature applies to your controller. When applicable to your controller, this pushbutton must be depressed immediately after the controller has completed its Power On Self Test and before holding the PTO Bar down to activate a motion control function. This will sound the system horn (when connected) and reset the main Equipment Power Contactor.



Notable Performance and Safety Features, continued.

LEVER GUARD BAR (optional) – When additional lever switch protection against physical damage is required, this fixed bar extends upwards from both ends and across the front of the controller.

INTERNAL TILT SWITCH – If the controller is tilted in any axis beyond 60 degrees of upright for longer than the programmed time (typically 3 seconds), a programmable function is sent automatically. This function can be assigned in the decoder to stop the equipment, sound an alarm, or both. Reset time is also programmable.

OPERATING FREQUENCIES - A variety of RF transmitters are available allowing controller operation in 72-76 MHz, 402-420 MHz, and 450-470 MHz bands on licensed radio channels and 447-471 MHz on unlicensed channels. Most models in the 450 MHz range are synthesized (16 frequency channels maximum).

APPLICATIONS - The paddle controller can operate any digital series receiver/decoder built by CATTRON-THEIMEG™. It can be used with existing CATTRON-THEIMEG™ systems as a replacement or as an extra transmitter/encoder.

Frequently Asked Questions.

Refer to Table 1-1 below for the most frequently asked questions about your paddle controller.

Table 1-1. Paddle Controller, questions and answers

QUESTION	ANSWER
SAFETY	
Protection against operator becoming disabled or falling down?	YES - fitted with a tilt switch and Push to Operate (PTO) safety bar switch as standard
Protection against accidental switch operation?	YES - PTO safety bar switch and toggle switches are protected by housing design. Spring return to OFF
Simple operation by position and feel (without looking at controller)?	YES - Levers are large enough for easy glove operation. Unique shape knobs available. Detent for speed steps (5)
High quality custom labeling?	YES – Customized text and arrows, large size, durable mylar
Number of functions sent to activate a motion?	TWO (lever and PTO)
Protection against false commands or data as battery discharges?	YES - Low battery warning, then cut off prior to reaching unstable levels
Protection against stray radio signals and other Remote Control systems?	YES - Unique digital address sent at the beginning of each data message.
Protection against other digital data radio (e.g., pagers, cell, fax) or radiation from computer equipment?	YES - Unique (non-standard) data baud rate, each motion command has data in at least two bytes, very complex data error detection (BCH)
Protection against broken switches or wiring sending motion commands?	YES - Switches (potentiometers) are tested for neutral at power on and for open or shorted wiring before each digital message. Potentiometers tested for travel beyond end of range and digital A/D converters tested constantly
Withstand static discharge and high magnetic fields?	YES - Unit tested for EMI/RFI by independent lab. Passes and can carry CE mark. Has been used successfully in high magnetic fields.



Frequently Asked Questions, continued.

Table 1-1. Paddle Controller, questions and answers

QUESTION	ANSWER
RELIABILITY	
Durable case material?	YES - Aluminum with epoxy coating. 'Neoprene' rubber bumper ends
Enclosure water/dust/oil resistant?	YES - NEMA 12 (IP-65)
Long motion switch operating life?	YES – Greater than 1 million operations
Reliable switch wiring?	YES – Switches are potentiometers, wired using silver coated multi-strand teflon coated wire and gold plated connectors. Only 3 wires per 'switch'
Simple and reliable electrical connection method to battery?	YES - Stainless steel contacts that mate with stainless pads on battery. Automatic wiping at each insertion into controller
Ability to survive repeated drops on to concrete floor?	YES - Tested by UL labs to mil-specs. Drops will not cause motion
Maximum number of function speed steps per motor available?	Uses potentiometers for all motion functions - 5 step each direction or stepless typical
State of the art electronic construction techniques?	YES - Machine built PC board (1) using surface mount components primarily
MAINTAINABILITY	
High quality component grades used?	YES - Industrial and mil-spec
Internal antenna?	YES – Slot design, printed circuit board construction, integral part of lower front housing on unlicensed controllers. Optional external antennas available.
Operator diagnostics - battery condition indication?	YES - TWO stage battery condition indicator: flash GREEN – OK. Flash RED – battery needs changing, audible beeps every 10 seconds anytime red indicator is flashing.
Operator diagnostics - determining switch operation condition?	YES - Can be placed in switch beep mode by turning on power while unit is tilted. Beep when a motion control function switch is operated indicates switch functioning correctly.
Data transmit indicator?	YES – GREEN LED flashes with each message being sent (will normally be synchronized with receiver LED's)
Easy Disassembly and Assembly?	YES - by CATTRON-THEIMEG™ trained customer technicians only. Minimal wires and few connections
PC diagnostics capability?	YES - by CATTRON-THEIMEG™ trained customer technicians only. PC testing port, cable, and diagnostic software available. Helps real time troubleshooting
Test method for RF frequency, modulation and related tests?	YES - by CATTRON-THEIMEG™ trained customer technicians only. Unit can be placed in a special test mode by holding PTO bar down while turning on power (also prevent operator tampering)



Frequently Asked Questions, continued.

Table 1-1. Paddle Controller, questions and answers

QUESTION	ANSWER
OPERATIONAL FEATURES	
FCC approval for narrow band licensed operation in new 12.5 kHz channels?	YES - Approved for both non-licensed and licensed services with ongoing designs for changing USA and Canadian rules and regulations. Transmitters can be assigned 12.5kHz channels. In addition, units have a wide number of approvals and frequency ranges for European, UK and Australian operation
Operational range without Close Start or Range limited receiver /decoder (Maximum distance)?	Low power (unlicensed) units typically 300 feet for operation indoors in an industrial environment. 500 feet outdoors under best conditions Licensed units typically 800 to 1000 feet indoors. Higher power M840 option is available for operation up to 1 mile outdoors, depending on a variety of operational and environmental factors which may reduce the actual operating range. A typical example of the above would be a locomotive application with TALKBACK™ operating at 330 mW using an 'on board' 5dB antenna.
Special display features for operator?	YES - LED (day/night) optional - selects data to be sent e.g., door number to control. LCD or individual LED's available for Talkback
Weight?	3-paddle unit (P03) weighs approximately 6.5 pounds with battery pack. Optional lightweight end-caps available which will reduce weight by 1 lb
Carrying methods available to provide comfortable, (all day) operation?	YES - Normally carried using a belt and shoulder harness combination. This places the unit at the belly. A back support (wide elastic) belt and shoulder harness combination is optional

Standard Specifications.

- Case Material: Epoxy powder coated Anodized Aluminum Extrusion with Molded Rubber End Caps.
- Weight: 3-Paddle Unit (P03) - approximately 6.5 lbs. (3 Kgs), including Battery Pack.
- Dimensions: 3-Paddle Unit (P03) - Height: 5.9" (15 cm) Depth: 6.7" (17 cm) Width: 9.5" (24 cm).
- Environmental: -4° F to +140° F (-20° C to +60° C), RH 0 to 95% Non-condensing.
- Switch Types: Spring Return to Center Toggle, Maintained Toggle, Momentary Pushbutton, Rotary Select.
- Lever Switch Choices: Detented (5-steps each side of center) or Stepless (analog) Spring Forward Idle and 8-steps for Throttle, Etc.
- Lever Styles: Large Flag. Special Shaped Lever Knobs Optional.



Standard Specifications, continued.

Number of Motor Functions:	3 (3-Paddle), 4 (4-Paddle), 5 (5-Paddle), or 6 (6-Paddle). Additional motor functions are available – contact your CATTRON-THEIMEG™ sales representative for details
Auxiliary Functions:	15 digital ON/OFF.
Push To Operate Safety Bar:	Standard.
Lever Guard Bar:	Optional – extends from both sides across the front above the levers.
Labeling:	Mylar, Multi-layer, Large
Keylock Switch:	Optional (Power ON/OFF).
Antenna:	Internal (external antenna optional on licensed versions only).
Low Battery Indicator:	2 Color LED: GREEN - Battery Normal, RED - Battery Low.
Short Circuit Protection:	Automatically Resettable Polyswitch™ (no fuses).
Conformal Coating:	Standard on PC Board.
Transmitter Frequency:	Synthesized and Crystal Control Models 72-76 MHz, 402-420 MHz, or 450-470 MHz - License Required. 447-471 MHz - No License Required.
Power Output:	450-470 MHz: typically between 20 and 40 mW. 402-420 MHz: typically between 20 and 40 mW. 72-76 MHz: 60 mW Nominal. 447-471 MHz: Maximum According to FCC Rules Part 15. 402-420 MHz, or 450-470 MHz M840 transmitter/transceiver (licensed) option adjustable from 80-450 mW
Synthesized Channels:	16 Maximum (Factory Programmed).

Overview – CATTRON-THEIMEG™ Radio Remote Control Systems

Figure 1-1 below shows a simplified block diagram of a typical CATTRON-THEIMEG™ radio remote control system. Refer to this figure and the following paragraphs for a functional description of the remote control system.

The target receiver/decoder is controlled by the Paddle Controller, which sends signals to the receiver/decoder using a UHF radio link. The signal is picked up by the antenna and passed on to the receiver. Provided the frequency of the paddle controller exactly matches that of the target receiver and passes all data tests, the signal is passed on to the decoder.

The decoder compares the address code of the signal to its own address code. If the signal's address code does not match the decoder's address code, it is ignored and a message is displayed on a system status display usually located in the receiver/decoder unit. If the address code is correct, the decoder processes the message and energizes and de-energizes the appropriate control and auxiliary function relays located within the control system.

An Automatic Safety Override (ASO) function continually monitors the state of any directional relay output (i.e. Forward/Reverse). If a monitored relay electrically fails closed without a command from the controller, the ASO circuit logic de-energizes the master output relay (OPR) which should be connected to the mainline contactor of your controlled machine.

During operation, the microprocessor on the decoder board resets multiple watchdog timer circuits whenever valid messages are received and decoded. If the microprocessor fails to reset the watchdog timers, the timer circuits shut down and de-activate all relay outputs. The decoder microprocessor requires continuously valid transmitted signals to be received and decoded or all relay output functions will be de-activated unless programmed otherwise. It should be noted that the mainline control relay (OPR) may be maintained for up to 10 minutes, depending on system configuration.

Figure 1-1. Typical Radio Remote Control System - simplified block diagram

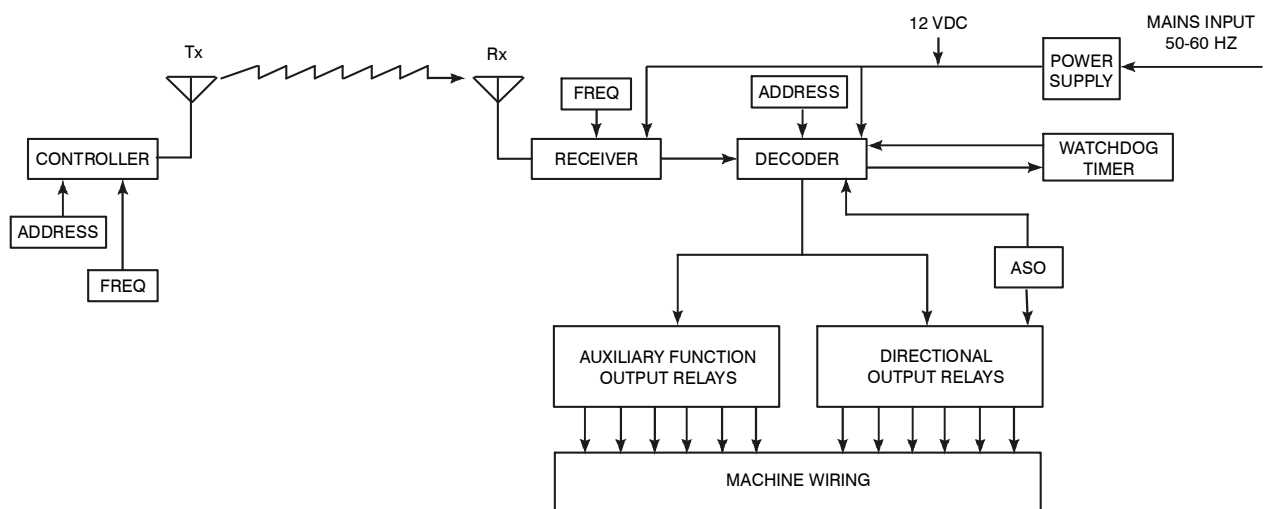

END OF SECTION



This page intentionally left blank



Section 2 – Safety Information

Safety Considerations.

CATTRON-THEIMEG™ believes that to safely operate any remotely controlled equipment, the overall system needs to be configured so that movement or operation of the equipment will take place only when the device is commanded to move or operate. For example, overhead cranes or locomotives must be equipped with a braking system that can only be released when an electrical signal is sent to the motor. Removal of electrical power or loss of the radio transmitted signal results in application of the brakes. On cranes, this is provided when a CATTRON-THEIMEG™ Electro-Hydraulic brake package is installed – contact the factory for details. On locomotives, an air valve opens, applying independent braking and the throttle returns to idle.

In keeping with this philosophy - **NO COMMAND, NO MOVEMENT** - CATTRON-THEIMEG™ has designed your radio remote control system with the following safety and security features which may, at your request, be modified to meet specific operating requirements. CATTRON-THEIMEG™ engineers are always available to work with you to provide optimum operating system safety.

Safety & Security Features.

Unique address code: Each controller and receiver/decoder pair is configured with a unique address code so that the equipment will respond only to the controller whose address code matches that of the decoder.

Intelligent digital message protocol: CATTRON-THEIMEG™ remote control systems utilize a unique message protocol for industrial control applications rather than the customary Electronic Data Processing (EDP) type of message format.

Power ON/OFF switch: The controller has a power ON/OFF Key or Toggle Switch that must be set to 'ON' in order to send commands to the receiver/decoder. If the power ON/OFF Switch is set to 'OFF', the decoder will remove all commands from the controlled machinery, stopping all movement. However, the mainline control relay (OPR) may be maintained for up to 10 minutes, depending on system configuration.

Operate relay (OPR): The operate (OPR) output relay shall be wired to control a user-provided electro-magnetic power contactor. The electro-magnetic contactor opens and closes the main electrical supply circuit(s) to the controlled device.

Automatic Safety Override: The Automatic Safety Override (ASO) function continually monitors all selected decoder directional relay outputs. If a directional relay closes without command from the controller, the Operate (OPR) Relay immediately de-energizes. This prevents any movement of the controlled machine without command from the controller.



Safety & Security Features, continued.

Data Error Checking: All communications from the controller to the receiver/decoder contain error-checking information (BCH data error detection routines). The entire data command packet must pass error detection tests before being processed.

Push-To-Operate (PTO) Bar: This easily activated switch bar must be released when power is turned on, then pressed and held to enable the motion switch functions. Releasing the PTO during normal operation causes the controller to send neutral commands to the receiver/decoder. In certain cases the PTO will be programmed NOT to enable or disable a particular function switch, i.e. some locomotive braking functions. Refer to the schematic drawing for your custom controller serial number to understand its configuration.

NOTE: Holding the PTO bar down when power is turned on places the controller in a technical diagnostic mode. Refer to Maintenance Instructions (Section 4) for details.

Optional 'Keyless Entry Code': This available feature requires an operator to activate a series of switches correctly before the controller power is turned on.

Typical method of operation (incorporating above safety features).

The Operate (OPR) relay is energized for the first time when:

The controller's Power ON/OFF Switch is set to 'ON' and the target receiver/decoder has power applied. With these conditions satisfied, a matching address code is sent by way of RF signal from the controller to the decoder.

The OPR relay is wired to the mainline (ML) contactor on the crane. Once the mainline is energized, a continuously repeated valid signal must be received for function outputs to engage. If this signal is interrupted for any reason, all function outputs will turn off unless programmed otherwise.

When operating within the USA, FCC rules state that RF transmitters in non-licensed controllers must switch off within five seconds after the operator releases a function button. Consequently, the OPR output is programmed to stay on for ten minutes after the last valid message is received. During this time all Automatic Safety Override (ASO) monitored outputs must stay off or the ASO sensing in the decoder will interrupt this hold up time, de-energizing OPR.

Figure 2-1 opposite shows an Operate (OPR) contact wired directly to the mainline (ML) contactor. Setting the controller's Power ON/OFF Switch to 'ON' will energize the mainline contactor.

An auxiliary function may be used as a Reset (RST) output that will only be effective when the Operate (OPR) relay has been closed. Momentary closure of the Reset (RST) relay picks up the mainline (ML) contactor, which is maintained under control of the OPR. Thus, power is supplied to the controlled device. If OPR opens, the mainline contactor releases, removing power from the controlled device and stopping all motion.

Typical method of operation (continued).

Figure 2-1. Operate (OPR) contact wiring

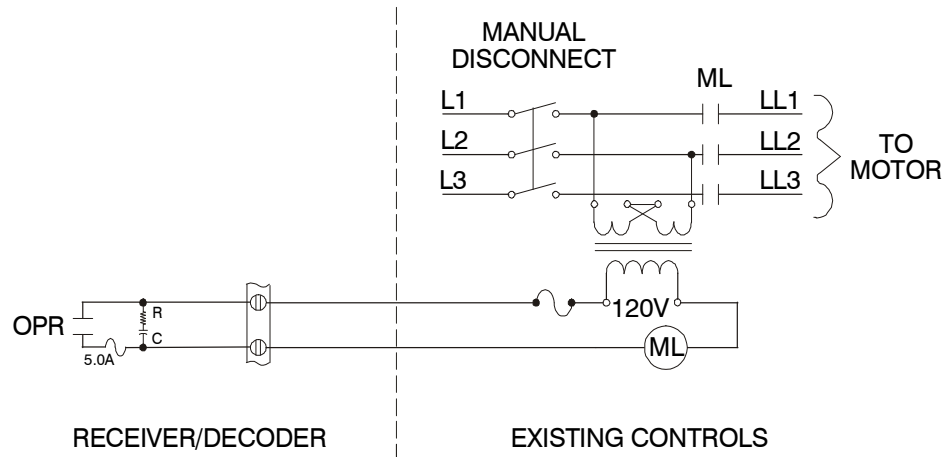
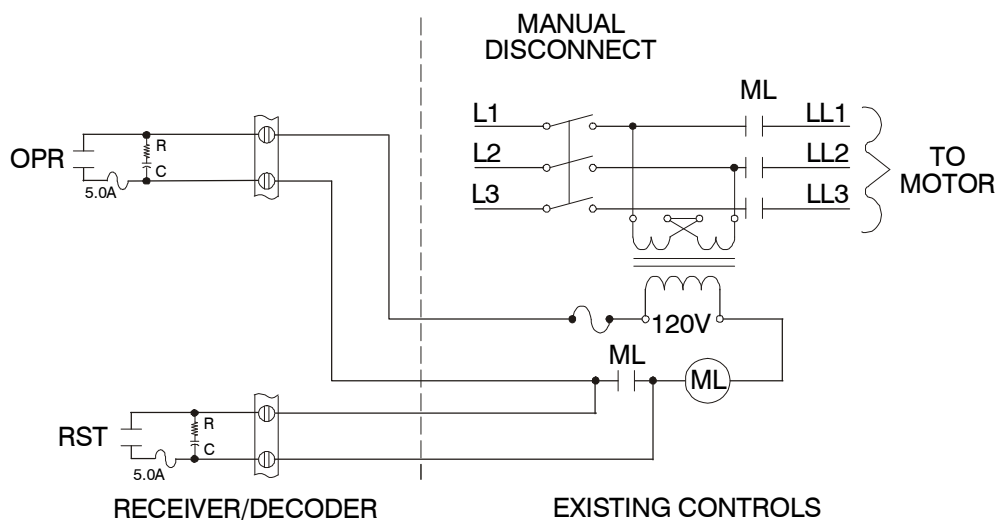

Figure 2-2 below shows the Operate (OPR) relay and optional Reset (RST) relay wired to control a mainline (ML) contactor. This configuration requires the operator to activate the reset function on the controller after he/she has turned the unit on. Once reset, the ML contactor stays energized until OPR de-energizes.

In addition to being energized by the presence of a signal from the controller, OPR is under supervision of the Automatic Safety Override (ASO) circuit. The ASO circuit disables the OPR (shutting down the controlled machinery) if a directional output relay is active when no corresponding command is being received from the controller. In this event, no action is required by the operator to stop the equipment. The ASO safety circuitry will stop motion automatically without any operator command when a directional output relay fault is detected.

Figure 2-2. Operate (OPR) contactor and Reset Relay (RST) wiring



Radio Control Operator's Duties – General Equipment.

WARNINGS:



WITH THE EXCEPTION OF LOCOMOTIVES, ALL EQUIPMENT MUST HAVE A MAINLINE (ML) CONTACTOR INSTALLED AND ALL TRACKED EQUIPMENT (i.e. CRANES) HAVE A BRAKE INSTALLED.

THE REMOTE CONTROL OPERATE (OPR) RELAY MUST BE CONNECTED TO THE MAINLINE SO THAT STOP COMMANDS OR FAULT CONDITIONS MONITORED BY AUTOMATIC SAFETY OVERRIDE (ASO) CIRCUITRY WILL DE-ENERGIZE THE MAINLINE CONTACTOR AND SET THE EQUIPMENT BRAKE.

FAILURE TO COMPLY WITH THE ABOVE WARNINGS MAY RESULT IN SERIOUS INJURY OR DEATH TO PERSONNEL AND DAMAGE TO EQUIPMENT.

WARNING:



MORE THAN ONE REMOTE CONTROL SYSTEM MAY BE USED AT, AROUND, OR NEARBY YOUR OPERATING FACILITY. THEREFORE, YOU MUST INSURE THE ADDRESS CODE AND FREQUENCY OF YOUR PADDLE CONTROLLER EXACTLY MATCHES THE ADDRESS CODE AND FREQUENCY OF THE DESIRED EQUIPMENT TO BE OPERATED.

FAILURE TO COMPLY WITH THE ABOVE WARNING MAY RESULT IN THE UNDESIRE OPERATION OF OTHER EQUIPMENT WHICH, IN TURN, COULD RESULT IN SERIOUS INJURY OR DEATH TO PERSONNEL AND DAMAGE TO EQUIPMENT.

WARNING:



ON CAB AND REMOTE OPERATED CRANES OR CARRIERS AN AUDIBLE OR VISUAL WARNING MEANS SHALL BE PROVIDED. IN ADDITION, ALL EQUIPMENT SHALL HAVE AUDIO OR VISUAL ALARM INDICATIONS MEETING GOVERNMENTAL REQUIREMENTS. FAILURE TO IMPLEMENT THIS WARNING MAY RESULT IN SERIOUS INJURY OR DEATH TO PERSONNEL AND DAMAGE TO EQUIPMENT.

Radio Control Operator's Duties – General Equipment, continued.



WARNING:

DUE TO FCC PART 15 AND DOC RSS-210 RADIO TRANSMIT REGULATIONS, THE OPR OUTPUT TO WHICH YOUR CONTROLLED EQUIPMENT'S MAINLINE CONTACTOR IS CONNECTED WILL REMAIN ENERGIZED FOR TEN MINUTES AFTER THE CONTROLLER POWER IS SET TO 'OFF', OR FOR TEN MINUTES AFTER THE LAST TIME A FUNCTION SWITCH IS ACTIVATED. CONSEQUENTLY, SPECIAL CARE MUST BE TAKEN IF THE CRANE OR TRACKED MACHINE IS EQUIPPED WITH A PARKING BRAKE THAT IS CONFIGURED TO ENGAGE WHEN THE MAINLINE CONTACTOR DE-ENERGIZES.

TO PREVENT A POTENTIALLY HAZARDOUS SITUATION, YOU SHOULD IMMEDIATELY SELECT THE RED 'STOP' FUNCTION ON YOUR REMOTE CONTROLLER AFTER COMPLETION OF OPERATIONS. SUCH ACTION WILL INSURE THE PARKING BRAKE (IF EQUIPPED AND CONFIGURED AS ABOVE) IS SET, PREVENTING UNINTENTIONAL MOVEMENT OF THE CRANE OR TRACKED MACHINE.

FAILURE TO COMPLY WITH THIS WARNING MAY RESULT IN SERIOUS INJURY OR DEATH TO PERSONNEL AND DAMAGE TO EQUIPMENT.



WARNING:

NEVER DISABLE THE PUSH TO OPERATE (PTO) BAR SWITCH ON YOUR REMOTE CONTROLLER. FAILURE TO COMPLY WITH THIS WARNING MAY RESULT IN DAMAGE TO EQUIPMENT, SERIOUS INJURY, OR DEATH.



Important Safety Note:

When using the controller, operators are instructed to wear a factory approved carrying harness with the controller attached at all times. If a controller must be left unattended, the STOP switch (when installed to the controller) should be depressed and the controller's power ON/OFF switch set to 'OFF'. If the power ON/OFF switch is a key switch, the key should also be removed to prevent unauthorized use of the controller.



Radio Control Operator's Duties – General Equipment, continued.

The following procedures provide general guidelines for radio control operation of equipment and should not be used as a substitute for your plant operating procedures.

1. Before operating equipment, carry out the following:
 - a. Insure the address code and frequency of your paddle controller exactly matches the address code and frequency of the target equipment to be operated.

The address and frequency assigned to your controller is recorded (1) on the front page of this manual, and (2) on a serial tag located inside the battery door. The address and frequency of the target receiver/decoder is recorded (1) on the front page of the manual supplied with the portable remote control system, and (2) on a label located inside the receiver/decoder.

If a controller having the wrong address code and frequency is selected, the target equipment will not operate. However, other equipment located at, around, or nearby your facility may become operational.

NOTES: If you are not familiar with the controls and indicators on your controller, please refer to 'Controls and Indicators' in Section 3 of this manual and the operational description provided with your controller.

Some controllers have two power ON/OFF switches (a Keyswitch and a Toggle switch). Both of these switches must be set to 'ON' for power to be applied to the controller.

- b. Set the controller's Power ON/OFF Switch(es) to the 'ON' position. When transmitting with a good battery, two short 'beeps' will be heard immediately after the Power ON/OFF Switch is set to 'ON' and a green TRANSMIT LED will 'flash' rhythmically. When the battery starts to go low, the green LED changes to a **red** LOW BATTERY LED which 'flashes' continuously. This means you should change or re-charge the battery pack as soon as possible - refer to **Battery Packs and Battery Pack Charging** in Section 3 of this manual.
- c. When installed, depress the ALARM/RESET push button switch located in the center of the PTO bar (this is normally an optional function that sounds the equipment alarm or horn and resets the main power contactor).
- d. Check each function independently to be sure that equipment is responding correctly.
- e. Where a limit switch is provided, you should check the limit switch at the beginning of each shift as defined by your plant operating procedures.
- f. Check Range Limiting if used – refer to Appendix 'A' of the manual supplied with your PRC system.
- g. Check STOP operation
- h. Check brake operation.



Radio Control Operator's Duties – General Equipment, continued.

2. You must report all defective or missing safety equipment, mechanical or electrical defects to your supervisor without delay. Do not continue operation until fully repaired.
3. If anyone is in the path of equipment travel, stop and sound the alarm before proceeding. Do not proceed until the pathway is clear
4. Persons operating this equipment shall not use a limit stop as a utility stopping device.
5. When leaving the equipment area for any reason, set the controller's Power ON/OFF Switch(es) to the 'OFF' position. If a Key Switch is installed, remove the key from the controller and keep it on your person.
6. Do not allow any unauthorized person to operate the controller.
7. Do not operate the controller at a distance where the equipment and all surrounding objects are not visible.
8. Do not attempt to override any of the safety features built into the Radio Control System.
9. If, for any reason, you or anyone has to board the radio controlled equipment, set the controller's Power ON/OFF Switch(es) to the 'OFF' position. If a Key Switch is installed, remove the key from the controller and keep it on your person.



Radio Control Operator's Duties – Electrical Overhead Traveling (EOT) Crane.

WARNINGS:



ALL EQUIPMENT MUST HAVE A MAINLINE (ML) CONTACTOR INSTALLED AND ALL TRACKED EQUIPMENT (i.e. CRANES) HAVE A BRAKE INSTALLED.

THE REMOTE CONTROL OPERATE (OPR) RELAY MUST BE CONNECTED TO THE MAINLINE SO THAT STOP COMMANDS OR FAULT CONDITIONS MONITORED BY AUTOMATIC SAFETY OVERRIDE (ASO) CIRCUITRY WILL DE-ENERGIZE THE MAINLINE CONTACTOR AND SET THE EQUIPMENT BRAKE.

FAILURE TO COMPLY WITH THE ABOVE WARNINGS MAY RESULT IN SERIOUS INJURY OR DEATH TO PERSONNEL AND DAMAGE TO EQUIPMENT.

WARNING:



MORE THAN ONE REMOTE CONTROL SYSTEM MAY BE USED AT, AROUND, OR NEARBY YOUR OPERATING FACILITY. THEREFORE, YOU MUST INSURE THE ADDRESS CODE AND FREQUENCY OF YOUR PADDLE CONTROLLER EXACTLY MATCHES THE ADDRESS CODE AND FREQUENCY OF THE DESIRED EQUIPMENT TO BE OPERATED.

FAILURE TO COMPLY WITH THE ABOVE WARNING MAY RESULT IN THE UNDESIREED OPERATION OF OTHER EQUIPMENT WHICH, IN TURN, COULD RESULT IN SERIOUS INJURY OR DEATH TO PERSONNEL AND DAMAGE TO EQUIPMENT.

WARNING:



ON CAB AND REMOTE OPERATED CRANES OR CARRIERS AN AUDIBLE OR VISUAL WARNING MEANS SHALL BE PROVIDED. IN ADDITION, ALL EQUIPMENT SHALL HAVE AUDIO OR VISUAL ALARM INDICATIONS MEETING GOVERNMENTAL REQUIREMENTS. FAILURE TO IMPLEMENT THIS WARNING MAY RESULT IN SERIOUS INJURY OR DEATH TO PERSONNEL AND DAMAGE TO EQUIPMENT.

Radio Control Operator's Duties – EOT Crane, continued.



WARNING:

DUE TO FCC PART 15 AND DOC RSS-210 RADIO TRANSMIT REGULATIONS, THE OPR OUTPUT TO WHICH YOUR CONTROLLED EQUIPMENT'S MAINLINE CONTACTOR IS CONNECTED WILL REMAIN ENERGIZED FOR TEN MINUTES AFTER THE CONTROLLER POWER IS SET TO 'OFF', OR FOR TEN MINUTES AFTER THE LAST TIME A FUNCTION SWITCH IS ACTIVATED. CONSEQUENTLY, SPECIAL CARE MUST BE TAKEN IF THE CRANE OR TRACKED MACHINE IS EQUIPPED WITH A PARKING BRAKE THAT IS CONFIGURED TO ENGAGE WHEN THE MAINLINE CONTACTOR DE-ENERGIZES.

TO PREVENT A POTENTIALLY HAZARDOUS SITUATION, YOU SHOULD IMMEDIATELY SELECT THE RED 'STOP' FUNCTION ON YOUR REMOTE CONTROLLER AFTER COMPLETION OF OPERATIONS. SUCH ACTION WILL INSURE THE PARKING BRAKE (IF EQUIPPED AND CONFIGURED AS ABOVE) IS SET, PREVENTING UNINTENTIONAL MOVEMENT OF THE CRANE OR TRACKED MACHINE.

FAILURE TO COMPLY WITH THIS WARNING MAY RESULT IN SERIOUS INJURY OR DEATH TO PERSONNEL AND DAMAGE TO EQUIPMENT.



WARNING:

NEVER DISABLE THE PUSH TO OPERATE (PTO) BAR SWITCH ON YOUR REMOTE CONTROLLER. FAILURE TO COMPLY WITH THIS WARNING MAY RESULT IN DAMAGE TO EQUIPMENT, SERIOUS INJURY, OR DEATH.



Important Safety Note:

When using the controller, operators are instructed to wear a factory approved carrying harness with the controller attached at all times. If a controller must be left unattended, the STOP switch (when installed to the controller) should be depressed and the controller's power ON/OFF switch set to 'OFF'. If the power ON/OFF switch is a key switch, the key should also be removed to prevent unauthorized use of the controller.



Radio Control Operator's Duties – EOT Crane, continued.

The following procedures provide general guidelines for radio control operation of an EOT crane and should not be used as a substitute for your plant operating procedures. **Please note that a complete set of Recommended Safety Rules for Cranes is provided at the end of this manual.**

1. Before lifting any loads, carry out the following:
 - a. Insure the address code and frequency of your paddle controller exactly matches the address code and frequency of the target equipment to be operated.

The address and frequency assigned to your controller is recorded (1) on the front page of this manual, and (2) on a serial tag located inside the battery door. The address and frequency of the target receiver/decoder is recorded (1) on the front page of the manual supplied with the portable remote control system, and (2) on a label located inside the receiver/decoder.

If a controller having the wrong address code and frequency is selected, the target equipment will not operate. However, other equipment located at, around, or nearby your facility may become operational.

NOTES: If you are not familiar with the controls and indicators on your controller, please refer to 'Controls and Indicators' in Section 3 of this manual and the operational description provided with your controller.

Some controllers have two power ON/OFF switches (a Keyswitch and a Toggle switch). Both of these switches must be set to 'ON' for power to be applied to the controller.

- b. Set the controller's Power ON/OFF Switch(es) to the 'ON' position. When transmitting with a good battery, two short 'beeps' will be heard immediately after the Power ON/OFF Switch is set to 'ON' and a green TRANSMIT LED will 'flash' rhythmically. When the battery starts to go low, the green LED changes to a **red** LOW BATTERY LED which 'flashes' continuously. This means you should change or re-charge the battery pack as soon as possible - refer to **Battery Packs and Battery Pack Charging** in Section 3 of this manual.
- c. When installed, depress the ALARM/RESET push button switch located in the center of the PTO bar (this is normally an optional function that sounds the equipment alarm and resets the main power contactor).
- d. Where a limit switch is provided, you should check the limit switch at the beginning of each shift as defined by your plant operating procedures.
- e. Check each function independently to be sure that equipment is responding correctly.
- f. Check range limiting if used – refer to Appendix 'A' of the manual supplied with your PRC system.
- g. Check STOP operation.
- h. Check Brake operation.



Radio Control Operator's Duties – EOT Crane, continued.

2. You must report all defective or missing safety equipment, mechanical or electrical defects to your supervisor without delay. Do not continue operation until fully repaired.
3. When raising or lowering a load, proceed slowly and make certain the load is under control.
4. When lifting maximum load, you should test the brakes by raising the load a few inches from the floor. If the brakes will not hold, the load shall be immediately lowered and not moved until brakes are adjusted or repaired.
5. Center the Trolley directly over the load before starting to hoist.
6. Take slack out of chains or slings gradually and make sure hands and other objects are clear before making the lift.
7. Keep all parts of the body away from the lifts. Also, do not stand under a lift.
8. Do not make a lift or move the equipment if anyone is in a position to be injured.
9. Load should not be carried over workmen's heads.
10. If anyone is in the path of travel, stop and sound the alarm before proceeding. Do not continue until the pathway is clear.
11. Do not drag slings, chains, etc. along the floor.
12. Persons operating this equipment shall not use a limit stop as a utility stopping device.
13. Bumping other cranes or run-away stops is prohibited.
14. When moving the equipment to the loading point, be sure that hook block, attachment, or cables will not fall on the adjacent equipment.
15. When leaving the crane area for any reason, be sure slings or chains are raised and set the controller's Power ON/OFF Switch(es) to the 'OFF' position. If a Key Switch is installed, remove the key from the controller and keep it on your person.
16. Do not allow any unauthorized person to operate the controller.
17. Do not operate the controller at a distance where the crane and all surrounding objects are not visible.
18. Do not attempt to override any of the safety features built into the Radio Control System.
19. If, for any reason, you or anyone has to board a radio controlled crane, set the controller's Power ON/OFF Switch(es) to the 'OFF' position. If a Key Switch is installed, remove the key from the controller and keep it on your person.



Radio Control Operator's Duties - Locomotive.

WARNINGS:



ALL TRACKED EQUIPMENT (i.e. LOCOMOTIVES) MUST HAVE A BRAKE INSTALLED.

THE REMOTE CONTROL OPERATE (OPR) RELAY MUST BE CONFIGURED SO THAT STOP COMMANDS OR FAULT CONDITIONS MONITORED BY AUTOMATIC SAFETY OVERRIDE (ASO) CIRCUITRY WILL SET THE THROTTLE TO IDLE, DISCONNECT THE GENERATOR FIELD, AND SET THE INDEPENDENT BRAKE.

FAILURE TO COMPLY WITH THE ABOVE WARNINGS MAY RESULT IN SERIOUS INJURY OR DEATH TO PERSONNEL AND DAMAGE TO EQUIPMENT.

WARNING:



MORE THAN ONE REMOTE CONTROL SYSTEM MAY BE USED AT, AROUND, OR NEARBY YOUR OPERATING FACILITY. THEREFORE, YOU MUST INSURE THE ADDRESS CODE AND FREQUENCY OF YOUR PADDLE CONTROLLER EXACTLY MATCHES THE ADDRESS CODE AND FREQUENCY OF THE DESIRED EQUIPMENT TO BE OPERATED.

FAILURE TO COMPLY WITH THE ABOVE WARNING MAY RESULT IN THE UNDESIRED OPERATION OF OTHER EQUIPMENT WHICH, IN TURN, COULD RESULT IN SERIOUS INJURY OR DEATH TO PERSONNEL AND DAMAGE TO EQUIPMENT.

WARNING:



ON CAB AND REMOTE OPERATED LOCOMOTIVES OR CARRIERS AN AUDIBLE OR VISUAL WARNING MEANS SHALL BE PROVIDED. IN ADDITION, ALL EQUIPMENT SHALL HAVE AUDIO OR VISUAL ALARM INDICATIONS MEETING GOVERNMENTAL REQUIREMENTS. FAILURE TO IMPLEMENT THIS WARNING MAY RESULT IN SERIOUS INJURY OR DEATH TO PERSONNEL AND DAMAGE TO EQUIPMENT.

WARNING:



NEVER DISABLE THE PUSH TO OPERATE (PTO) BAR SWITCH ON YOUR REMOTE CONTROLLER. FAILURE TO COMPLY WITH THIS WARNING MAY RESULT IN DAMAGE TO EQUIPMENT, SERIOUS INJURY, OR DEATH.

Radio Control Operator's Duties - Locomotive, continued.



Important Safety Note:

When using the controller, operators are instructed to wear a factory approved carrying harness with the controller attached at all times. If a controller must be left unattended, the STOP switch (when installed to the controller) should be depressed and the controller's power ON/OFF switch set to 'OFF'. If the power ON/OFF switch is a key switch, the key should also be removed to prevent unauthorized use of the controller.

The following procedures provide general guidelines for radio control operation of a locomotive and should not be used as a substitute for your plant operating procedures. **Please note that a complete set of Recommended Safety Rules for Locomotives is provided at the end of this manual.**

1. Perform all locomotive pre-departure tests according to the locomotive manufacturer's operation manual. Do not proceed unless the locomotive is operating satisfactorily according to the manufacturer's instructions.
2. Before departure, carry out the following:
 - a. Insure the address code and frequency of your paddle controller exactly matches the address code and frequency of the target equipment to be operated.

The address and frequency assigned to your controller is recorded (1) on the front page of this manual, and (2) on a serial tag located inside the battery door. The address and frequency of the target receiver/decoder is recorded (1) on the front page of the manual supplied with the portable remote control system, and (2) on a label located inside the receiver/decoder.

If a controller having the wrong address code and frequency is selected, the target equipment will not operate. However, other equipment located at, around, or nearby your facility may become operational.

NOTES: If you are not familiar with the controls and indicators on your controller, please refer to 'Controls and Indicators' in Section 3 of this manual and the operational description provided with your controller.

Some controllers have two power ON/OFF switches (a Keyswitch and a Toggle switch). Both of these switches must be set to 'ON' for power to be applied to the controller.

- b. Set the controller's Power ON/OFF Switch(es) to the 'ON' position. When transmitting with a good battery, two short 'beeps' will be heard immediately after the Power ON/OFF Switch is set to 'ON' and a green TRANSMIT LED will 'flash' rhythmically. When the battery starts to go low, the green LED changes to a **red** LOW BATTERY LED which 'flashes' continuously. This means you should change or re-charge the battery pack as soon as possible - refer to **Battery Packs and Battery Pack Charging** in Section 3 of this manual.



Radio Control Operator's Duties - Locomotive, continued.

- c. Depress the HORN switch on the controller. **The horn should sound on the target locomotive.**
- d. Check each brake function independently to be sure the locomotive is responding correctly to all brake applications, including emergency stop and release commands. Observe gages in the cab for proper readings and verify that the brake cylinders are moving properly.
- e. Test train brakes (if equipped).
- f. Check all auxiliary equipment, such as bell, headlight, sanders, uncouple, etc.
3. You must report all defective or missing safety equipment, mechanical or electrical defects to your supervisor without delay. Do not continue operation until fully repaired.
4. When ready to move the locomotive for the first time, proceed slowly and make certain the load is under control.
5. Take the slack out of the couplers gradually and make sure hands and other objects are clear before making command.
6. Keep all parts of the body away from the rolling equipment and **never walk on the tracks ahead of the train.**
7. Do not move the locomotive if anyone is in a position to be injured.
8. If anyone is in the path of travel, stop and sound the horn. Do not proceed until the tracks are clear.
9. Heavy bumping of cars or stops is prohibited.
10. When leaving the locomotive for any reason, be sure the locomotive throttle is set to 'IDLE' and the brakes are fully applied. Set the controller's Power ON/OFF Switch(es) to the 'OFF' position. If a Key Switch is installed, remove the key from the controller and keep it on your person.
11. Do not allow any unauthorized person to operate the controller.
12. Do not operate the controller at a distance where the locomotive, railcars, rail-track, and all surrounding objects are not visible.
13. Do not attempt to override any of the safety features built into the Radio Control System.
14. If, for any reason, you or anyone has to board a radio controlled locomotive or train, set the controller's Power ON/OFF Switch(es) to the 'OFF' position. If a Key Switch is installed, remove the key from the controller and keep it on your person.

END OF SECTION

Section 3 – Operating Instructions

Controls and Indicators.

Each paddle controller has been designed and custom built for a specific remote control application, therefore its operation will differ from model to model. For this reason, it is not possible to describe an individual controller's switch and indicator configuration in this manual – there are too many variations. However, all paddle controllers incorporate some or all of the controls and indicators identified in Figure 3-1 below. For your controller's exact switch and indicator configuration, please refer to the schematic drawing provided with your paddle controller.

Figure 3-1. Paddle Controller – controls, indicators and features

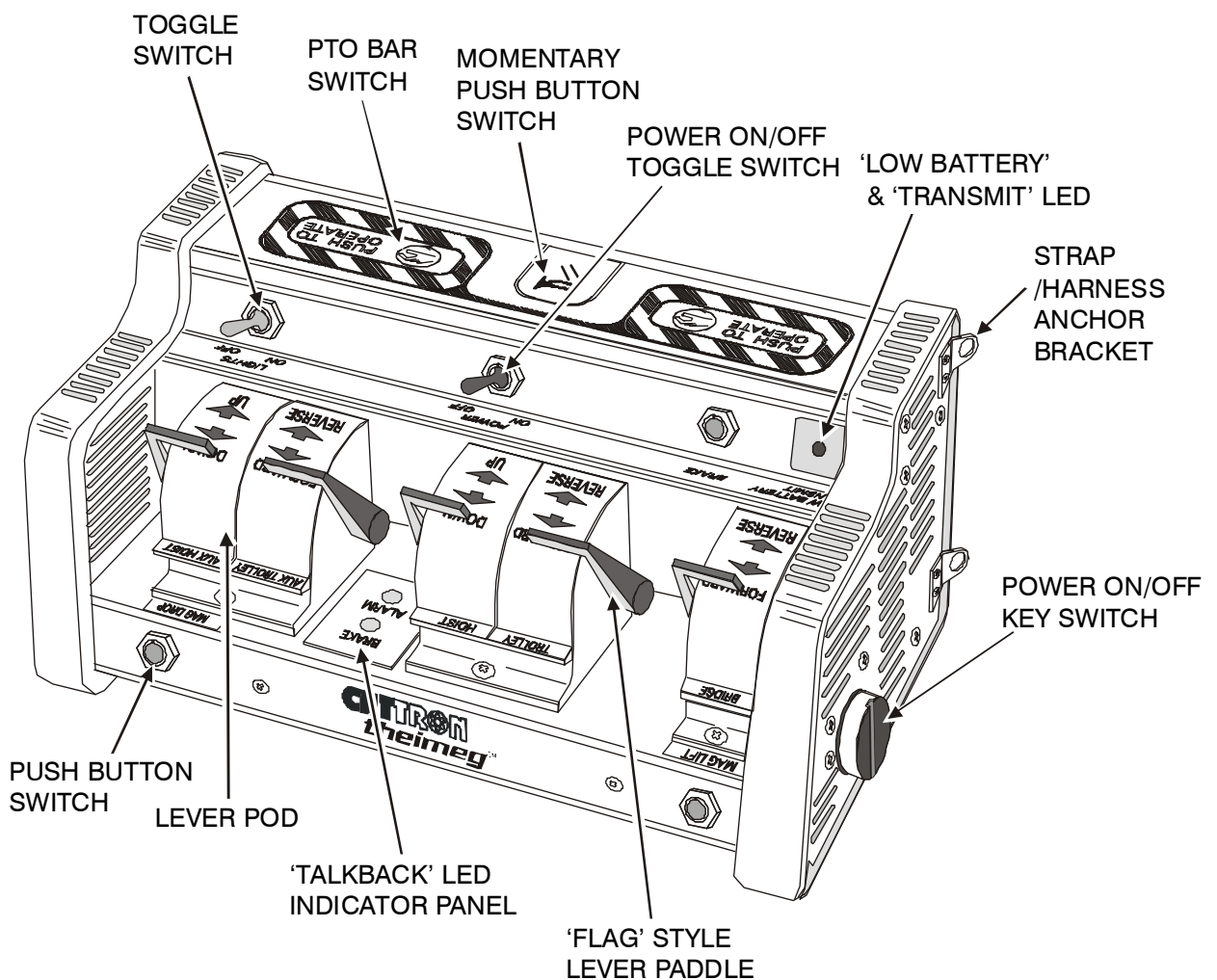



Controls and Indicators, continued.

POWER ON/OFF KEY SWITCH – This key switch prevents unauthorized personnel from operating the control system. When the key switch is set to 'ON', internal battery power is applied to an RF encoder/transmitter within the controller and the operator can control all auxiliary (non-motion) functions without pressing the PUSH-TO-OPERATE (PTO) bar. The power ON/OFF key switch controls a mainline magnetic contactor on the machine. This in turn controls the main power to the machine motors. When the controller is not in use, the key may be withdrawn from its switch location and kept on the operator's person. **Note that: (1) a front panel mounted, maintained 2-position toggle switch may be substituted for this side mounted key switch, and (2) some controllers may have both types of these power ON/OFF switches installed.**

POWER ON/OFF TOGGLE SWITCH – When this switch is set to 'ON', internal battery power is applied to an RF encoder/transmitter within the controller and the operator can control all auxiliary (non-motion) functions without pressing the PUSH-TO-OPERATE (PTO) bar. The power ON/OFF key switch controls a mainline magnetic contactor on the machine. This in turn controls the main power to the machine motors. **Note that: (1) on some controllers, a side mounted, key switch may be substituted for this front panel mounted toggle switch, and (2) some controllers may have both types of these power ON/OFF switches installed.**

PUSH-TO-OPERATE (PTO) BAR - This bar is a large, full length, spring-return switch located on top of the unit that is generally used as a safety device that electronically disconnects all motion switches when it is released, thus stopping motion commands from these switches. The PTO bar is easily and naturally activated by a convenient and comfortable part of the operator's hand and **must** be depressed and maintained before and when any motor or motion command is initiated. It should be noted that operation of the PTO bar is not required for auxiliary functions, i.e. magnet, lights, etc. For the exact configuration of the PTO Bar, refer to the custom drawing package supplied with your controller.

LEVER POD(S) – Up to six lever pods can be installed to your paddle controller and you should refer to the custom drawing package supplied with your controller for the specific configuration. These switches may be 11-position, spring return-to-center switches, stepless levers, or dual axis joysticks. For cranes with stepped output there are five forward (or down) positions, five reverse (or up) positions, and a center 'OFF' (or neutral) position. Each of the five positions, in either direction, selects a different motor speed. The motor speed increases as the switches are moved away from the center position in each direction. The crane motors may have fewer than five speeds. For example, cranes with two speed motors where the third, fourth, and fifth position of the switches operate the motors at the highest speed which is speed two. As viewed from the operator's position, the crane motor control levers are normally labeled from left to right; BRIDGE, TROLLEY, and HOIST. If used with a four-motor crane system, an AUX HOIST control lever is located on the extreme right of the unit.

Locomotive controller lever positions are laid out according to the user's requirements and you should refer to the custom drawing package supplied with your controller. Normal locomotive configuration as viewed left to right from the operator's position is: THROTTLE, DIRECTION, INDEPENDENT BRAKE and TRAIN BRAKE.



Controls and Indicators, continued.

In addition to the 'Flag' style lever paddle (illustrated), different style levers and knobs are available – refer to 'Accessories' in Section 5 of this manual for details. Finally, some controllers are built with a special two-axis joystick configuration - refer to special operation descriptions and the custom drawing package supplied with your controller for specific information.

SWITCHES – A momentary push button switch is mounted in the center of the PTO bar, and up to six switches can be located in front of the PTO bar. Two additional switches may be located below the lever pods when two finger application is required to prevent the accidental operation of safety critical functions such as 'MAGNET' 'GRAB', and 'VACUUM'. Depending upon the control application, your controller may be configured with some or all of the following switch types:

- Rotary selector or key switch – mainly used for address selection
- Maintained 2-position toggle – mainly used for auxiliary 'ON/OFF' functions (lights, application of sand, and power up)
- Momentary pushbutton, or toggle – mainly used for non motion functions (horn, brake, alarm/reset, magnet lift, magnet drop)

TRANSMIT & LOW BATTERY LED – This LED is part of the battery management system and flashes green when the controller's Power ON/OFF Switch is set to 'ON' and the controller is transmitting with a good battery installed. The LED flashes red when the battery is low and sounds a beeper to alert the operator. In addition, a low battery cut-off circuit stops the controller micro-processor when voltage goes below safe operating range. This is because RF transmitters always operate at full power over the entire life of the battery.

'TALKBACK™' LED INDICATOR PANEL – This feature adds two-way data communication to the CATTRON-THEIMEG™ Portable Radio Remote Control (PRRC) System when used in conjunction with the MP96 Series Receiver/Decoder. In the standard PRRC System, all data communication is a type of one-way communication: namely, control information sent from the operator's controller to the receiver/decoder. With TALKBACK™ the decoder can communicate back to the controller. Up to sixteen ON/OFF bits of information can be sent back from the MP96 decoder to the paddle controller. These bits originate in the MP96 decoder and can be either External Event Inputs or ASO Inputs. The received bits are displayed on the controller using up to twelve light emitting diodes and/or a Liquid Crystal Display (LCD).

The decoder will make a TALKBACK™ transmission to the controller about once every second. Since the encoder and decoder are both making transmissions on the same frequency, more airtime is used. In this instance, timesharing multiple controllers on a single radio channel is not recommended.

Also, the controller's battery life will be reduced, sometimes significantly, depending on the type of indicating devices used (digital displays, LED's, etc.). For example, a controller operating on 450 MHz with a Ni-Cad battery pack will last 10 to 14 hours of continuous operation instead of 36 hours. It should be noted that Alkaline battery packs are not usable with TALKBACK™ systems.



Controls and Indicators, continued.

Your customized controller and PRRC system drawings will show the exact operation of your control unit. A typical example of TALKBACK™ would be its use on **radio controlled locomotives**.

On a locomotive there is usually a 'Tree' of four or five lights used as status indicators that is mounted on each side of the locomotive. These lights usually show the operator the status of 'FORWARD', 'REVERSE', 'THROTTLE', 'BRAKES', and Remote Control System 'ON'.

Consequently, the PRRC operator must always be close enough to the locomotive to see these lights in order to determine the status. However, with the TALKBACK™ option, status indications are transmitted back to the controller and displayed with LED's.

This enables the PRRC operator to assume a commanding view of the whole train and its operating area rather than just the locomotive.

Other fault indications can also be displayed. Examples are: Engine Alarm, Low Air Pressure, High Engine Water Temperature, Low Engine Oil Pressure, Wheels Slipping, STOP Switch Active, and Speedometer Digital Readout.

In the case of an **overhead crane**, the TALKBACK™ option enables status and external event information to be viewed on the controller. Because the PRRC operator is not required to climb the crane, or view the lights mounted on the crane to determine status, he or she is able to assume a commanding view of the entire crane operating area.

Some typical display indications for cranes are: Magnet Power ON, Magnet Lift ON, Operator ID Lights (pitch & catch), Mainline ON, Low Brake Pressure, Direction Verification, Out of Range (with Range Limiter), ASO Fault, Latched/Unlatched, Aligned (Zone), Hoist Limit Switch, Thermal Trip, and Under Voltage Trips.

General Operating Procedure.

NOTES: When using the controller, operators are instructed to wear a factory approved carrying harness with the controller attached at all times.

If a controller must be left unattended, the STOP Switch (when installed to the controller) should be depressed and the controller's POWER ON/OFF switch set to 'OFF'. If the POWER ON/OFF switch is a key switch, the key should also be removed to prevent unauthorized use of the controller (refer to Section 2, Page 7, Item 5 of this manual).

Using a Carrying Harness to support the controller will greatly enhance operator comfort and operational safety. Two harnesses are available, as illustrated below in Figures 3-2 and 3-3. Refer to these illustrations for details and CATTRON-THEIMEG™ Part Numbers.

Figure 3-2. Standard carrying harness

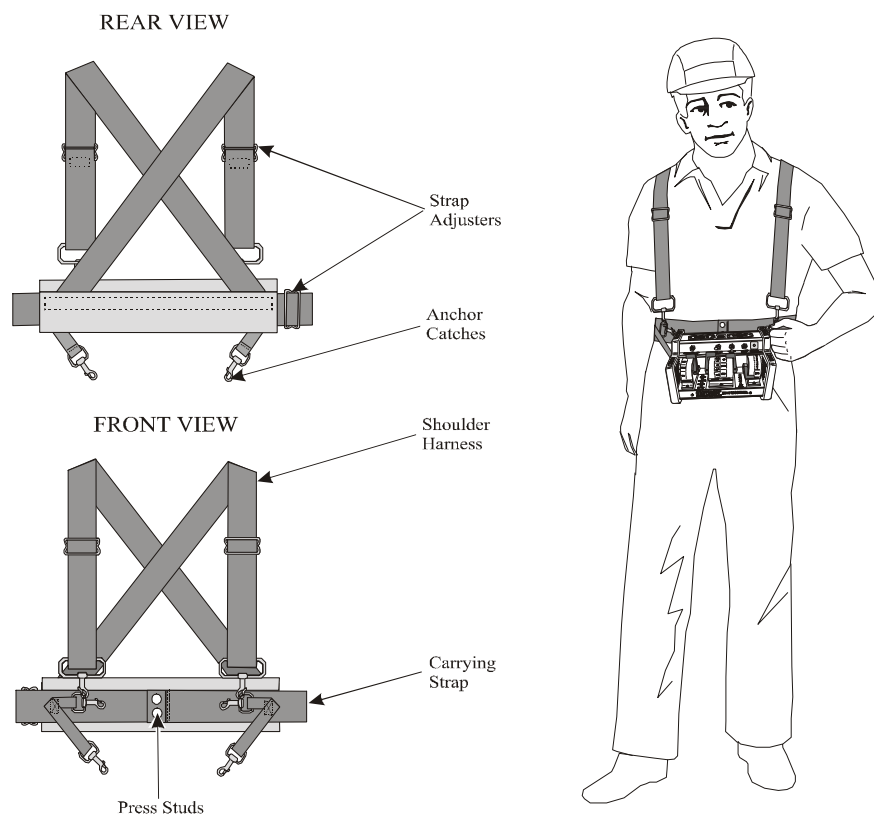

Standard Carrying Harnesses are available in 2 sizes as follows:

Part #	Size	To Fit Waist Sizes
CLN-6096	Small to Large	37.5 - 56 inches
CLN-6096XL	Extra Large	48 - 68 inches

General Operating Procedure, continued.

Figure 3-3. – ‘Low back’ support carrying harness

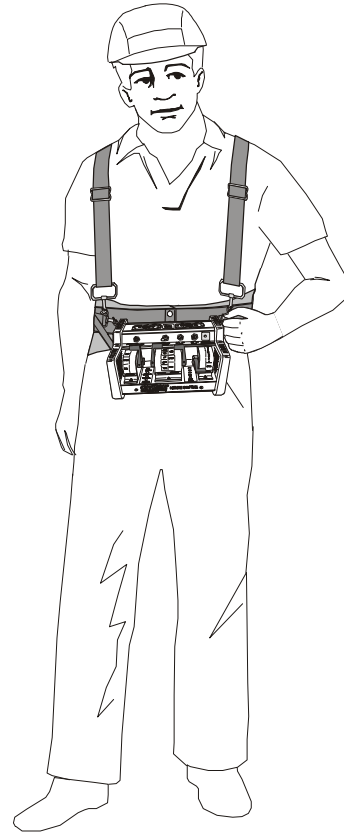
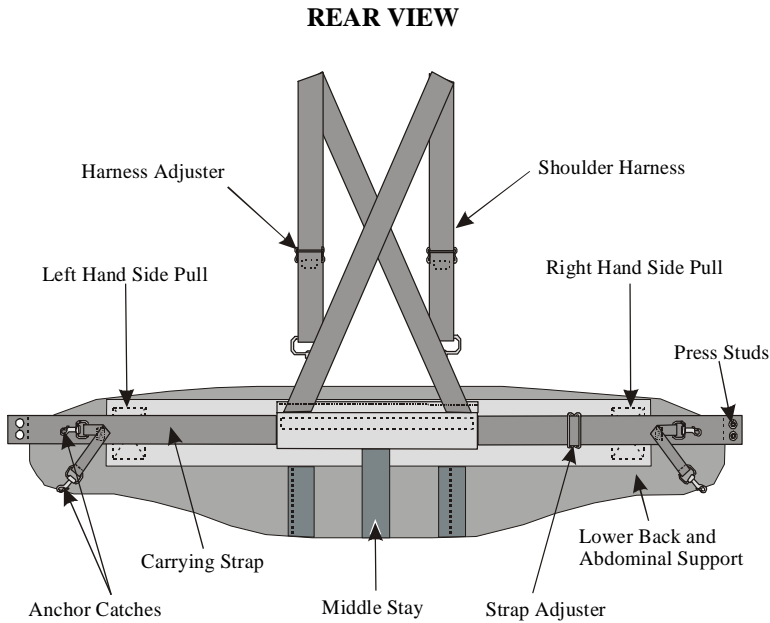

The Lower Back and Abdominal Support is a lightweight and comfortable device that acts as a reminder to lift properly. The Side Pulls give you the extra support needed when lifting. When on break or lunch, you may want to loosen the side pulls, but **DO NOT** forget to re-fasten them when returning to work.

NOTE: IF YOU HAVE OR HAVE HAD AN INJURY, CONSULT YOUR DOCTOR BEFORE USING THIS PRODUCT.

Low Back Support Carrying Harnesses are available as follows:

Part #	Size	To Fit Waist Sizes
CLN-300901XS	Extra Small	28 - 32 inches
CLN-300902S	Small	32 - 36 inches
CLN-300903M	Medium	36 - 40 inches
CLN-300904L	Large	40 - 44 inches
CLN-300905XL	Extra Large	44 - 48 inches
CLN-300906XXL	Double Extra Large	48 - 52 inches
CLN-300907XXXL	Triple Extra Large	52 - 56 inches

1. Referring to Figure 3-4 below, assemble and put on the carrying harness, attach the controller to the harness and adjust for comfortable operation.

General Operating Procedure, continued.

Figure 3-4. Carrying harnesses, assembly and fitting

LOW BACK SUPPORT
CARRYING HARNESS ONLY

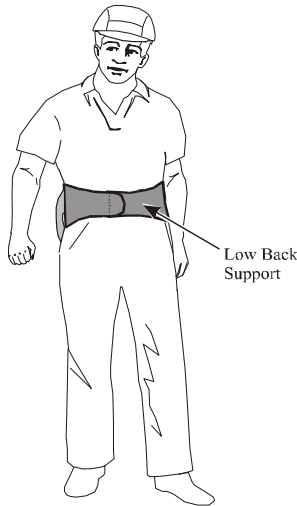

LOW BACK SUPPORT
CARRYING HARNESS ONLY

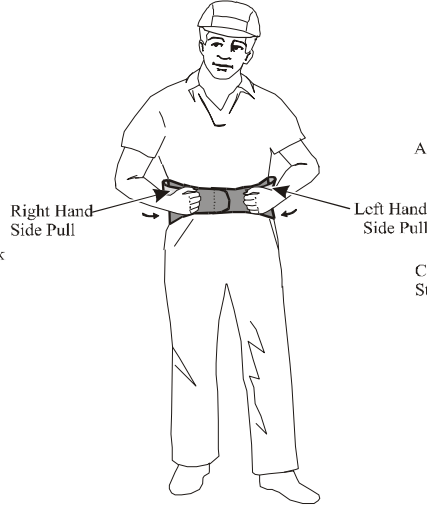

STANDARD AND LOW BACK SUPPORT
CARRYING HARNESSES

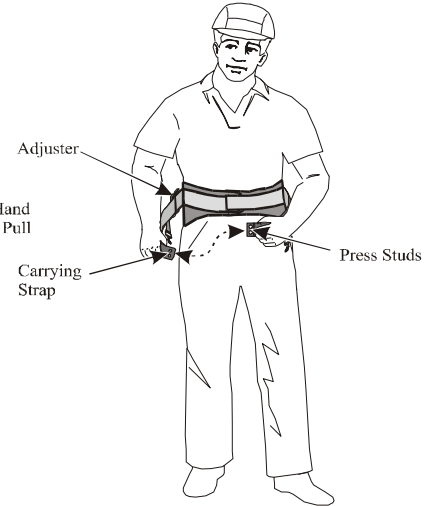

1-1. Place the Low Back Support around the body just below the navel, ensuring the Middle Stay (see Fig 3-3 above) locates in the center of the low back. Stretch the right end across the left and attach firmly.

1-2. Loosen elasticized Side Pulls and stretch forward as far as possible. Position the left hand side pull over the right hand side pull and attach firmly but comfortably.

1-3. Using Adjuster, lengthen or shorten Carrying Strap as necessary to provide a snug fit. Fasten Carrying Strap around waist using Press Studs.

STANDARD AND LOW BACK SUPPORT
CARRYING HARNESSES

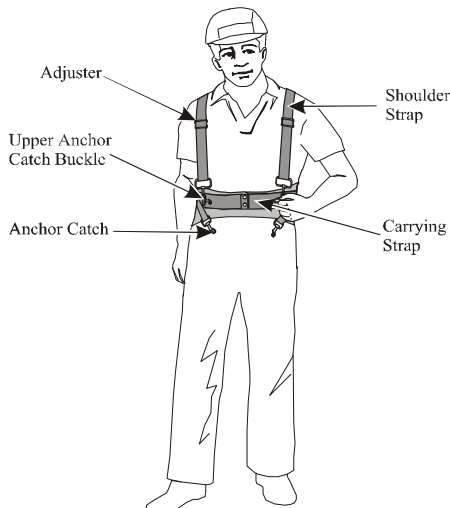

1-4. Cross the Shoulder Harness Straps at the back and bring each strap to the front. Adjust the length of the shoulder straps as required. Fasten the end catches of the shoulder straps into the buckles of the Upper Anchor Catches located on the Carrying Strap

STANDARD AND LOW BACK SUPPORT
CARRYING HARNESSES

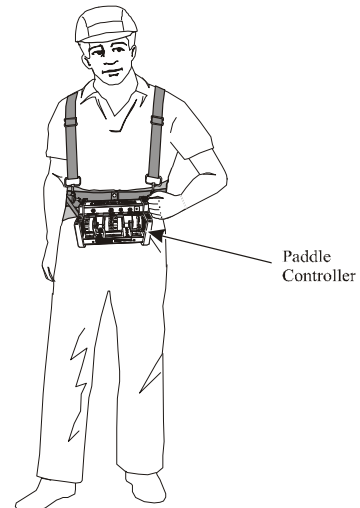

1-5. Fasten the Controller to the Harness using the four Anchor Catches located on the Carrying Strap. Re-adjust the harness as necessary for individual comfort and preference.



General Operating Procedure, continued.

NOTES: Holding the PTO bar down when power is turned on places the controller in a technical diagnostic mode - refer to Maintenance Instructions (Section 4) for details. The PTO bar must be up when starting the controller or the system will not operate.

On some controllers, the side mounted Power ON/OFF Key Switch may be replaced with a front panel mounted, 2-position maintained toggle switch. Alternatively, some controllers may have both types of these power ON/OFF switches installed.

2. Set the controller's Power ON/OFF Switch(es) to 'ON'. Observe that the TRANSMIT/LOW BATTERY LED momentarily flashes yellow and two quick 'beeps' are heard. If the LED is red, replace or recharge the battery pack – refer to **Battery Packs and Battery Pack Charging** at the end of this section. When transmitting with a good battery pack, the green TRANSMIT LED should 'flash' rhythmically.
3. When your controller is equipped with the optional 'Keyless Entry Code' feature, an assigned sequence of function switches must be operated within 10 seconds after the Power ON/OFF Switch is set to 'ON'. These switches will not operate any functions and the controller power comes on only after the correct sequence has been entered.
4. When your controller is equipped with an ADDRESS SELECTOR SWITCH, operating this switch will change the system address, thus allowing a single controller to operate multiple controlled machines. Extreme caution should be used to insure that you do not select the wrong machine.



WARNING:

AFTER CHANGING AN ADDRESS OR FREQUENCY SELECTOR SWITCH, YOU MUST, IN THE FIRST INSTANCE, INSURE THE TARGETED MACHINE IS UNDER REMOTE CONTROL BEFORE OPERATING ANY MOTION FUNCTION SWITCH. THIS MAY BE ACCOMPLISHED BY OPERATING A NON MOTION FUNCTION SWITCH ON THE REMOTE CONTROLLER SUCH AS A HORN OR LIGHT.

FAILURE TO COMPLY WITH THE ABOVE WARNING MAY RESULT IN THE UNDESIRE OPERATION OF OTHER EQUIPMENT WHICH, IN TURN, COULD RESULT IN SERIOUS INJURY OR DEATH TO PERSONNEL AND DAMAGE TO EQUIPMENT.

General Operating Procedure, continued.

5. Place a convenient and comfortable part of either hand on the PUSH TO OPERATE BAR on top of the controller. This switch must be depressed and maintained before and when any motor or motion command is initiated.



WARNING:

NEVER DISABLE THE PUSH TO OPERATE (PTO) BAR SWITCH ON YOUR REMOTE CONTROLLER. FAILURE TO COMPLY WITH THIS WARNING MAY RESULT IN DAMAGE TO EQUIPMENT, SERIOUS INJURY, OR DEATH.

6. Operate the motion control lever switches as required, remembering that the levers must be pulled upward for all REVERSE and UP motions and pushed down for all FORWARD and DOWN motions. A speed increase is obtained by selecting different, appropriately marked lever switches. Compass direction labels (N, S, E, & W) may be located next to the appropriate switches.
7. While commanding a motion with a switch, release the PUSH TO OPERATE BAR without centering switch. The motion must stop - if this does not happen, set the controller's Power ON/OFF Switch to 'OFF' and notify your supervisor immediately.



TYPICAL CRANE CONTROL FUNCTIONS.

In addition to the controls and indicators described at the beginning of this section, some or all the control functions described and illustrated below may be applicable to your crane control application. Unless notified to the contrary, the following Control Functions do not require the PTO Bar to be pressed to enable their operation.

Figure 3-5. Crane Paddle Controller - Typical configuration

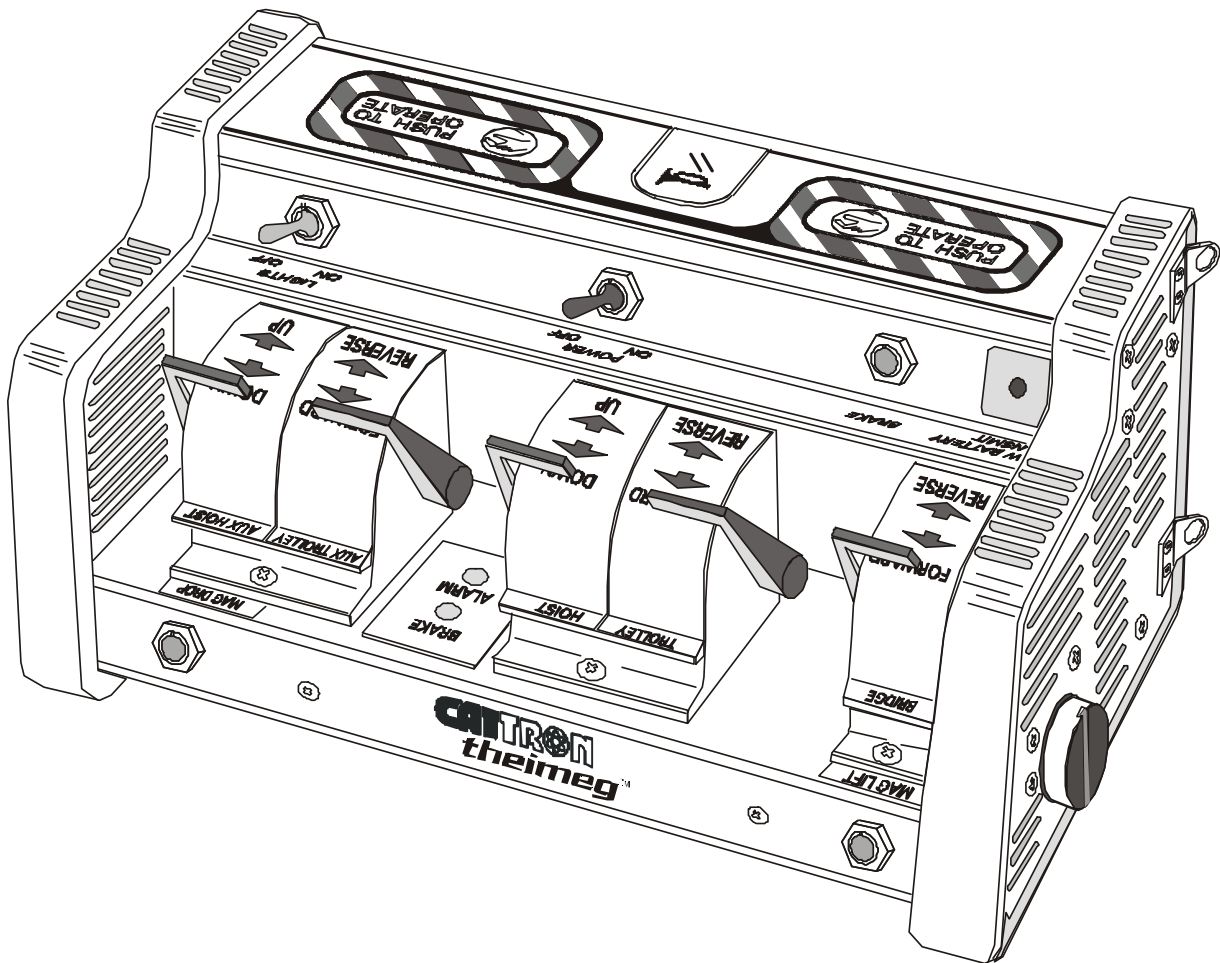



TYPICAL CRANE CONTROL FUNCTIONS, continued.

1. **ALARM, RESET or ALARM/RESET SWITCH.** When this momentary pushbutton switch located in the center of the PTO bar is used as an ALARM, it operates a bell, horn, or other warning device on the crane. When used as a RESET, this switch resets the mainline contactor when it has previously been switched or tripped OFF due to a relay failure or overload, thus allowing power to be supplied to the crane motors. When used as an ALARM/RESET, this switch operates the ALARM and RESET functions simultaneously.
2. **MAGNET, VACUUM, or GRAB.** Extra precautions are built into the MAGNET, VACUUM and GRAB functions to prevent accidental release. Two momentary switches (buttons or toggles) are normally used for these functions. Accidental operation of the magnet, vacuum or grab function is minimized by locating these buttons as far as possible from other controls and requires two fingers to release the load. The Standard Operating Procedure (SOP) for each of these functions is detailed below; however, this procedure may be changed, depending on the system application. Please note that any deviation from the SOP will be advised in the drawing package supplied with your PRC system.

Magnet To Lift, press and hold 'LIFT' for one second.
To Drop, press and hold 'LIFT', wait for one second, then press and hold 'DROP'.

After load is dropped, release 'LIFT' first, then release 'DROP'.

Vacuum To Lift, press and hold 'VACUUM' for one second.
To Drop, press and hold 'VACUUM', wait for one second, then press and hold 'RELEASE'.

After load is dropped, release 'VACUUM' first, then release 'RELEASE'.

Grab To Close, press 'CLOSE'.
To open, press and hold 'CLOSE', then press 'OPEN'.
After grab is opened, release 'CLOSE' first, then release 'OPEN'.

3. **BRAKE SWITCH** - This momentary pushbutton or toggle switch is used for manual control of the crane bridge brakes, usually a parking brake, or the second step of a running brake (first step normally comes on when motor is made neutral and released when direction is selected). Other brake functions are available such as PARKING BRAKE RELEASE, COAST, etc.
4. **HOOK/GRAB ROTATE SWITCH** - This control function is normally a spring return-to-center (OFF position) toggle switch. It allows a motorized hook or grab to be turned in either a clockwise (CW) or counter-clockwise (CCW) direction.
5. **CRANE LIGHT ON/OFF SWITCH** - This maintained toggle switch provides ON/OFF control of the crane lights. Proper decoder circuitry insures that they remain latched 'ON' if required.



TYPICAL CRANE CONTROL FUNCTIONS, continued.

6. CRANE SELECT SWITCH - This rotary selector or key switch is used when the controller operates more than one crane. The switch is used to select the desired crane by changing the controller's digital address. If switched while the unit is on, the power is switched off automatically for 10 seconds, then starts up automatically on the new address. **All motor and motion control lever switches on the controller must be neutral during this time.**



WARNING:

AFTER CHANGING AN ADDRESS OR FREQUENCY SELECTOR SWITCH, YOU MUST, IN THE FIRST INSTANCE, INSURE THE TARGETED MACHINE IS UNDER REMOTE CONTROL BEFORE OPERATING ANY MOTION FUNCTION SWITCH. THIS MAY BE ACCOMPLISHED BY OPERATING A NON MOTION FUNCTION SWITCH ON THE REMOTE CONTROLLER SUCH AS A HORN OR LIGHT.

FAILURE TO COMPLY WITH THE ABOVE WARNING MAY RESULT IN THE UNDESIRED OPERATION OF OTHER EQUIPMENT WHICH, IN TURN, COULD RESULT IN SERIOUS INJURY OR DEATH TO PERSONNEL AND DAMAGE TO EQUIPMENT.

7. OPERATOR RELEASE 'PITCH AND CATCH' (Optional) – 'Pitch and catch' is the operation of a single crane by two, three, or four operators on a first-come, first-served basis. This method provides lock out of the non-commanding operator(s) and allows only one operator at a time. An example of a two operator 'pitch and catch' operation follows:
 - 7-1. The crane is sitting idle and both controllers 'A' and 'B' are switched OFF.
 - 7-2. Operator 'A' turns his/her controller power to 'ON' and captures the crane. One of two colored lights on the crane, energized by auxiliary function relays in the receiver/decoder, indicates which operator has taken control of the crane. It should be noted that Operator 'A' remains in control even if Operator 'B' switches his or her controller power to 'ON' and attempts to control the crane – control access is denied to Operator 'B' at this time.
 - 7-3. Operator 'A' may release the control of the crane to Operator 'B' in one of two ways:
 - (1) The first way is by pressing the 'RELEASE' button on his/her controller ('pitch') after Operator 'B' has turned his/her controller power to 'ON' and is ready to take control of the crane. If Controller 'B' is transmitting the correct system identification address, Operator 'B' is allowed to take control ('catch'). Operator 'A' is now denied control access and should switch his/her controller power to 'OFF'.
 - (2) The second way to transfer control from Operator 'A' to Operator 'B' is to simply turn Controller 'A' power to 'OFF' for a designated period of time (typically 45 seconds). After this period of no transmission, if Controller 'B' power is set to 'ON' first, Operator 'B' will capture the crane.

TYPICAL LOCOMOTIVE CONTROL FUNCTIONS.

In addition to the controls and indicators described at the beginning of this section, some or all the control functions described and illustrated below may be applicable to your locomotive control application. Unless notified to the contrary, the following Control Functions do not require the PTO Bar to be pressed to enable their operation.

Figure 3-6. Locomotive Paddle Controller - Typical Configuration

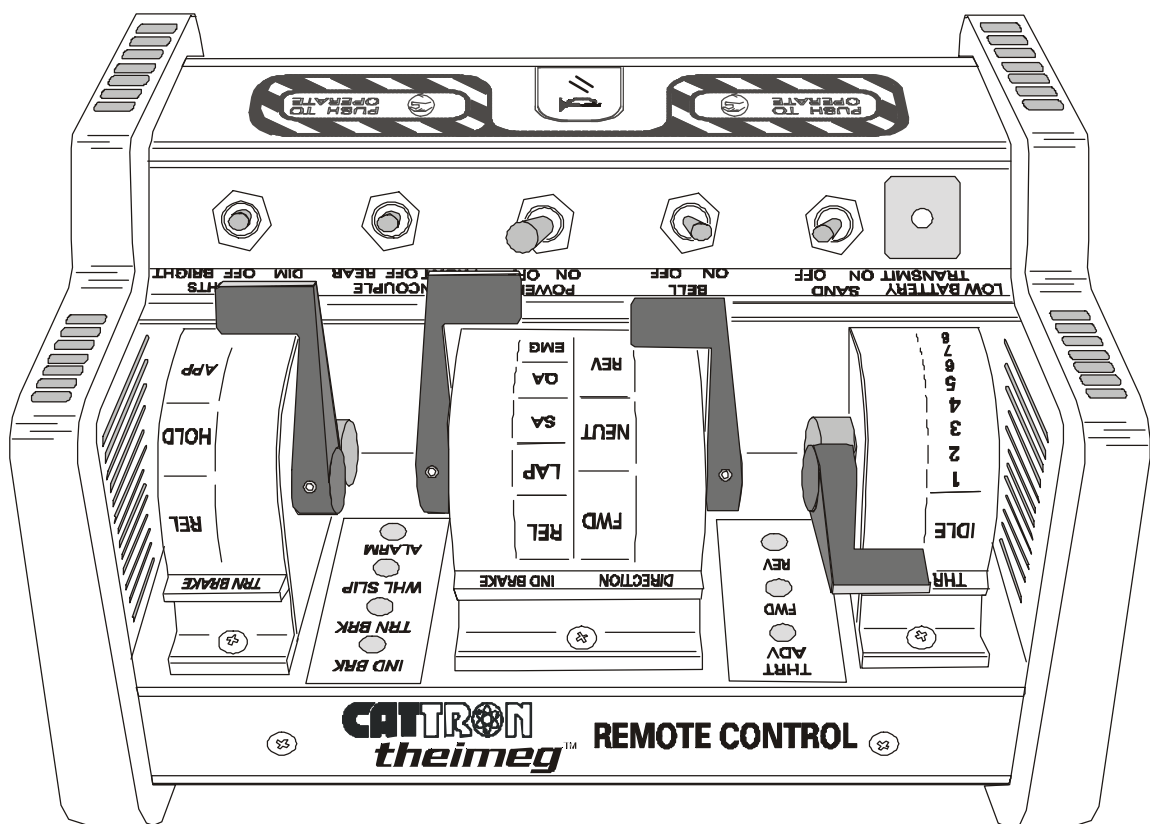

1. HORN - This momentary push button switch located in the center of the PTO Bar sounds the horn when pressed.
2. HORN/RESET – This momentary push button switch located in the center of the PTO Bar sounds the horn and provides the initial ‘RESET’ command to the radio receiver/decoder on the locomotive. **This switch must be activated after powering up the controller, otherwise the locomotive will not operate.** Observe that the horn will sound, thus identifying the locomotive is under radio control.



TYPICAL LOCOMOTIVE CONTROL FUNCTIONS, continued.

3. DIRECTION SWITCH – this maintained 3-position paddle switch controls ‘FORWARD’ and ‘REVERSE’ functions. If the lever is moved to the ‘NEUT’ (neutral or center) position, direction is disabled.

NOTE: A change in the Locomotive direction will not occur until the throttle is moved to idle for at least 3-seconds. Attempting to make a change in direction while the throttle is advanced will cause the throttle to return to idle. Some systems require that an independent brake is applied for 3 seconds, or a specific brake cylinder pressure has been reached, before a change in direction can occur.

4. THROTTLE LEVER - Controls the Locomotive throttle. This spring return-to-forward paddle switch spring returns to the ‘IDLE’ position when released. Note that the PTO Bar must be pressed to enable this control function. If the PTO Bar is released, the throttle will normally be returned to ‘IDLE’.

5. INDEPENDENT BRAKE LEVER - Controls the locomotive (independent) brakes using five maintained lever positions that provide the following braking functions:

‘REL’ - Releases the brakes.

‘LAP’ – Holds the independent brakes at the last applied pressure.

‘SA’ - Slow application of the independent brakes.

‘QA’ - Quick application of the independent brakes.

‘EMG’ – Applies train and independent brakes, including the application of sand.

Note that the PTO Bar must be pressed to release the brakes. In most control applications, when the PTO Bar is released, the independent brakes will be slowly applied.

6. ‘EMG BRAKE’ SWITCH – When set to the ‘EMG BRAKE’ position, this maintained 2-position toggle switch applies the train and independent brakes, together with the application of sand.

7. ‘TRAIN’ (AUTOMATIC) BRAKE LEVER - This 3-position switch lever or toggle switch controls the train brakes and has the following functions:

APPLY (Momentary) – Applies the railcar brakes by reducing the air supply to the train air line.

HOLD (Maintained) - Seals off the train air line so no further reduction or release will occur.

REL (Maintained) - Puts air into the train air line to release the railcar brakes.



TYPICAL LOCOMOTIVE CONTROL FUNCTIONS, continued.

8. SAND – This momentary toggle switch applies sand to the rails in the direction of travel when held in the ‘SAND’ position.
9. BELL - Sounds the locomotive bell when set to ‘ON’. This function may be programmed to activate with throttle or direction.
10. HEADLIGHT ‘OFF/DIM/BRIGHT’ – this maintained 3-position switch selects the desired brightness of the headlight in the direction of travel. In the ‘BRIGHT’ setting, the headlight at the front of the locomotive illuminates at full power, while the headlight at the rear of the locomotive or train is dimmed. In the ‘DIM’ position, both front and rear headlights will be dimmed.
11. UNCOUPLE – Provided there is no tractive pull on the couplers, setting this spring return-to-center (OFF position) switch to ‘FRONT’ or ‘REAR’ will retract the respective coupling pin from the front or rear of the locomotive.
12. ALERTER - If equipped with the ‘ALERTER’ option, a switch must be moved by the operator at least once every 20 seconds (or the amount of time you have programmed) or the controller beeper will sound. If no action is taken within the next 10 seconds, a function is sent to stop the locomotive. Moving any switch, including the PTO Bar, will reset the Alerter timeout.
13. OPERATOR RELEASE ‘PITCH AND CATCH’ (Optional) – Locomotive ‘pitch and catch’ allows two operators to swap control to and from each other, based upon which operator should be commanding movement. Typically, a selector switch mounted on the side of the locomotive mounted Receiver/decoder enclosure is used to select single or dual operator control.

When the switch is selected for two operators, the Receiver/decoder will not allow the locomotive to operate unless both transmitters are detected. If at any time, only one transmitter is detected, the throttle will return to idle and the brakes will set. While in two-operator mode, the primary controller operator will have control of all functions (i.e. throttle, direction, brakes, etc.) and be protected by the controller’s internal tilt switch.

The secondary controller operator will maintain control of the ‘HORN’, ‘BELL’, and ‘STOP’ functions, together with other auxiliary functions as designated at the time of system design. He or she will also be protected by the controller’s internal tilt switch.

For example, should either the primary or secondary operator fall, the Receiver/decoder will stop the locomotive (typically, setting throttle to idle, applying full independent brakes, sounding the horn for 10 minutes and, when installed, activating a ‘MAN DOWN’ alarm). **It must be noted that the operator who commands a tilt or ‘STOP’ shutdown must also be the one to ‘RESET’ the shutdown condition.**



TYPICAL LOCOMOTIVE CONTROL FUNCTIONS, continued.

In a typical locomotive 'pitch and catch' application, before a pitch can be made, the following conditions must be satisfied:

- The Locomotive must be stopped.
- Both controllers must be selecting 'NEUTRAL'.
- Both controllers must have the same selection on the 'INDEPENDENT' and 'AUTOMATIC' brake override switch.
- The primary controller operator must depress the 'OPERATOR RELEASE' pushbutton.
- The secondary controller operator must depress the 'OPERATOR ACCEPT' pushbutton.

As long as the above conditions are met, transfer of control will occur. In addition, if TALKBACK™ is available on your control system, a 'PRIMARY CONTROL' indicator will illuminate on the controller in full control.

Switch Diagnostic Mode.

In this mode the operator can easily check that **all** function switches (motion and non-motion) are fully operational.



WARNING:

ELECTRICAL POWER TO THE TARGET CONTROLLED EQUIPMENT MUST BE COMPLETELY ISOLATED TO PREVENT OPERATION UNDER REMOTE CONTROL IN THE SWITCH DIAGNOSTIC MODE.

FAILURE TO COMPLY WITH THE ABOVE WARNING MAY RESULT IN THE UNDESIRE OPERATION OF EQUIPMENT WHICH, IN TURN, COULD RESULT IN SERIOUS INJURY OR DEATH TO PERSONNEL AND DAMAGE TO EQUIPMENT.

This is accomplished by first turning off power to the controller using the Power ON/OFF Key and/or Toggle Switch. Then, place the controller in a tilted (horizontal) position with its battery door face down. To enable the switch diagnostic mode, re-apply power using the Power ON/OFF Switch(es) while the controller is in the horizontal position.

This mode of diagnostics activates the beeper when (1) each non-motion (auxiliary) toggle and pushbutton switch changes state, and (2) when any **motion** control lever/switch changes state, **provided the PTO Bar is pressed and held down each time the motion lever/switch changes state.**

For example, push any one of the auxiliary toggle switches UP and a single 'beep' will be heard. Release the toggle switch and another single 'beep' will be heard as the switch spring returns to center. Repeat this procedure on the remaining non-motion toggle and pushbutton switches in both UP/DOWN or ON/OFF positions. If the switches are functioning correctly, a 'beep' will be heard each time the switch changes state.

Repeat the above procedure on all **motion** control levers/switches, remembering to enable these motion functions by pressing and holding the PTO Bar down when operating a lever/switch. When an enabled motion lever/switch is functioning correctly, a 'beep' will be heard each time the device changes state.

To disable the switch diagnostic mode, simply turn the controller power to 'OFF', then re-apply power to the controller while it is in an upright position.



Battery Packs and Battery Pack Charging.

The following battery pack and charging options are available for your controller and may be ordered from your nearest CATTRON-THEIMEG™ facility identified on the back page of this manual.

Alkaline Battery Pack providing 75 hours of continuous operation. This battery pack is **not re-chargeable** and should be discarded when exhausted.

Nickel-Cadmium (Ni-Cad) Battery Pack providing approximately 23 hours of continuous operation. This battery pack is **re-chargeable** using the CATTRON-THEIMEG™ 70C-0004 Battery Conditioner.

Table 3-1. Battery Pack Options

CATTRON-THEIMEG™ PART NUMBER	TYPE	COLOR	LIFE OPERATING HOURS	RE-CHARGING TIME (using 70C-0004 Conditioner/charger)	LIFETIME CYCLES
C-8096	Ni-Cad Battery Pack	Yellow	23*	3-Hours	200+
60C-0023	Alkaline Battery Pack	White	75*	Do Not Charge	1

* Battery life operating hours are based on continuous transmissions.

Battery Conditioner - A CATTRON-THEIMEG™ Battery Conditioner (Part # 70C-0004) is available for use with CATTRON-THEIMEG™ C-8096 Ni-Cad Battery packs only.

Battery Pack Replacement.

When the TRANSMIT/LOW BATTERY LED starts flashing red, this alerts the operator that he or she has approximately one hour of continuous operation remaining, after which the battery pack must be replaced or re-charged.

Replace the battery pack as follows:

1. Set the controller's Power ON/OFF Switch(es) to the 'OFF' position.
2. Referring to Figure 3-7 opposite, unlock the battery door by inserting a coin into the slot and twisting.
3. Open the battery door and lift the battery pack out of the tray.
4. Install a fresh, fully charged battery pack in the controller, making sure the contacts on the underside of the battery pack locate with their corresponding pick-up contacts in the battery tray.

Battery Pack Replacement, continued.

5. Close the battery door and secure by pressing firmly until it snaps into the locked position.
6. Set the controller's Power ON/OFF Switch(es) to 'ON'. Observe that the TRANSMIT/LOW BATTERY LED momentarily flashes yellow and two quick beeps are heard.

When resuming your remote control operation, observe the TRANSMIT/LOW BATTERY LED as you operate a **non-motion function** toggle switch such as a horn or light. If this LED is now flashing green, your controller is fully operational.

Figure 3-7. Battery Pack Replacement.

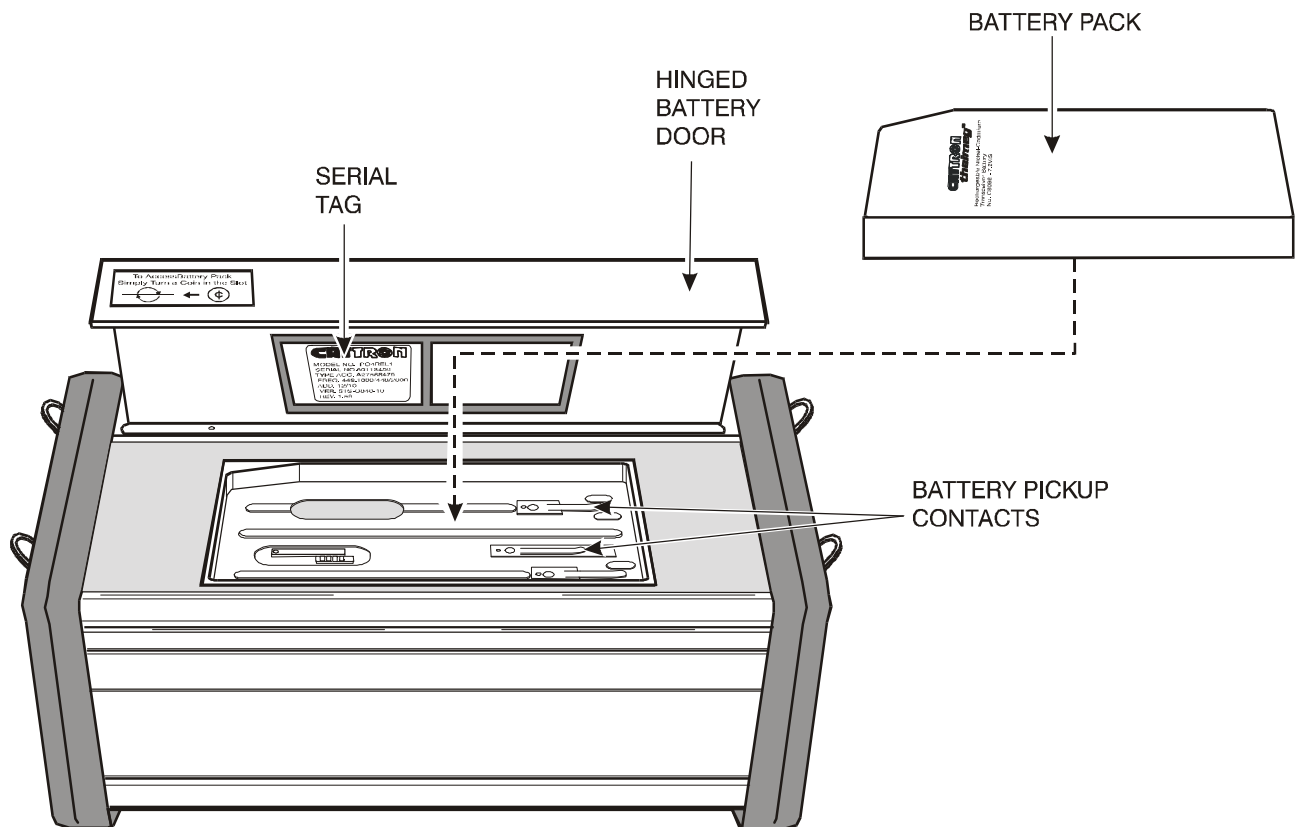



Ni-Cad Battery Pack Conditioning/Charging (Figure 3-8).



CAUTIONS:

(1) CATTRON-THEIMEG™ Battery Conditioners are designed for use with CATTRON-THEIMEG™ Ni-Cad Battery Packs only.

(2) Battery Packs must be removed or disconnected from Battery Conditioners within 48-hours of achieving the fully charged state.

Failure to comply with these Cautions may result in equipment and/or battery damage and will void our warranty.

A Ni-Cad battery pack must be removed from the controller's battery compartment for external charging. The Battery Conditioner includes a Mains VAC Adaptor that allows operation from mains supply voltages between 100 and 240VAC @ 50/60 kHz. Referring to Figure 3-8 opposite, this adaptor is connected as shown. Similarly, when installing the Ni-Cad Battery Pack to the Battery Conditioner, refer to Figure 3-8 for the appropriate locating instructions.

The Battery Conditioner automatically conditions the battery pack by first discharging it at 600mA for 2-hours before applying a rapid charge for 1-hour. The conditioner incorporates end of charge detection circuitry to accurately sense when the battery pack is fully charged. When this condition has been detected, the conditioner switches to a 'trickle' mode that keeps the battery pack fully charged and ready to use for up to 48-hours. To prevent damage to the battery pack, it should be removed from the conditioner within 48-hours of achieving a fully charged state.

The CATTRON-THEIMEG™ Battery Conditioner incorporates an LED that indicates status as follows:

Amber Color – indicates the battery pack is being discharged.

Red Color - indicates the battery pack is being charged at a rapid rate.

Green Color - indicates the battery pack is fully charged and that a 'trickle' charge is being applied to maintain the fully charged state. The battery pack is ready for use and should be removed from the conditioner within 48-hours.

Ni-Cad Battery Pack Conditioning/Charging , continued.

Figure 3-8. Ni -Cad Battery Pack Conditioning – interconnection details.

1. REAR VIEW - CONNECTING THE VAC ADAPTOR

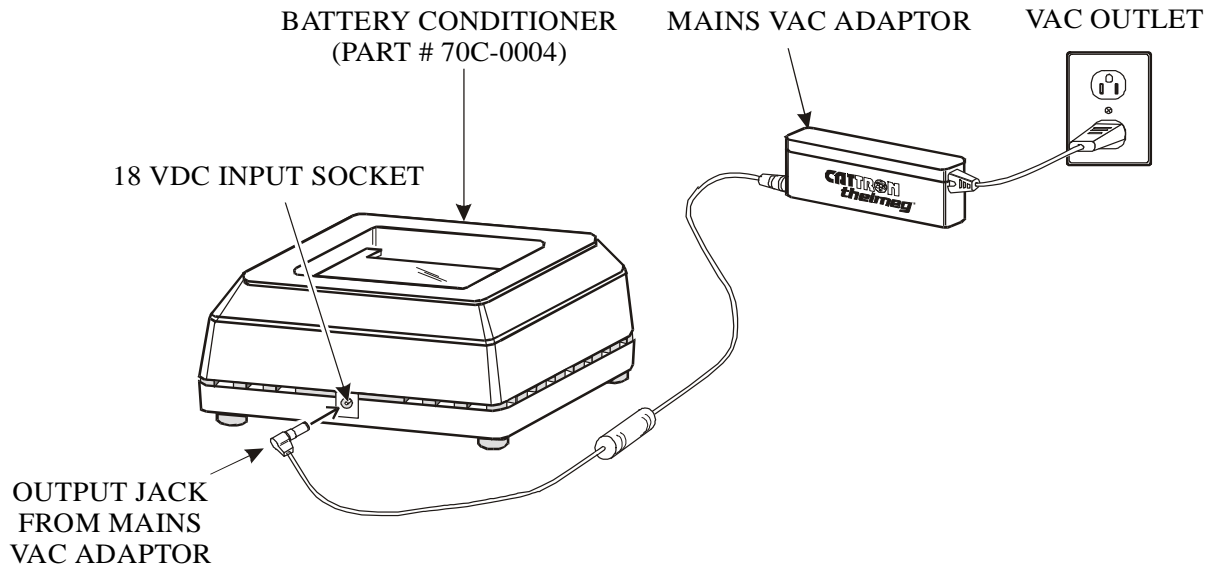

2. FRONT VIEW - INSTALLING THE BATTERY PACK

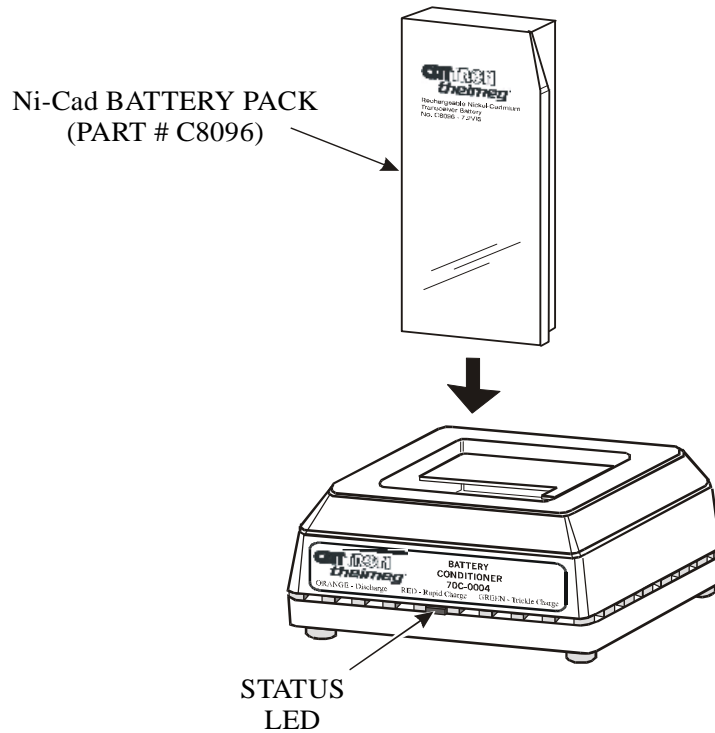



Pre-programmed Frequency Selection.

If your Controller will be used to operate more than one crane, locomotive, or controlled machine, or be used as a spare controller for multiple remote control systems, up to sixteen selectable frequencies may have been factory pre-programmed into the controller's EPROM.

To see if this selectable frequency option applies to your controller, refer to Figure 3-7 above and locate the serial tag on the inside of the battery door.

If the serial tag indicates a specific frequency in the **FREQ** line (i.e., 448.1000 MHz) the selectable pre-programmed frequency option does not apply to your controller.

If the serial tag indicates 'SELECTABLE' in the **FREQ.** line, refer to the frequency chart provided in your custom drawing package. This frequency chart will specify the pre-programmed channel frequencies available with your controller.

Pre-programmed Frequency Selection, continued.



WARNING:

MORE THAN ONE REMOTE CONTROL SYSTEM MAY BE USED AT, AROUND, OR NEARBY YOUR OPERATING FACILITY. THEREFORE, YOU MUST INSURE THE FREQUENCY OF YOUR PADDLE CONTROLLER EXACTLY MATCHES THE FREQUENCY OF THE DESIRED EQUIPMENT TO BE OPERATED.

FAILURE TO COMPLY WITH THE ABOVE WARNING MAY RESULT IN THE UNDESIRE OPERATION OF OTHER EQUIPMENT WHICH, IN TURN, COULD RESULT IN SERIOUS INJURY OR DEATH TO PERSONNEL AND DAMAGE TO EQUIPMENT.

To select a pre-programmed frequency, proceed as follows:

1. Record the operating frequency of the intended equipment to be controlled – this may be found on the front cover of the manual provided with the target receiver/decoder, or on a serial tag located inside the target receiver/decoder enclosure.
2. Referring to the Frequency Chart supplied with your controller drawing package, locate the controller frequency that matches the equipment operating frequency recorded in the previous step, noting its corresponding Channel Address Number which may be from ‘0’ thru ‘7’ or ‘A’ thru ‘F’.
3. Set the controller’s Power ON/OFF Switch(es) to ‘OFF’.
4. Referring to Figure 3-7 above, unlock the battery door by inserting a coin into the slot and twisting.
5. Open the battery door and remove the battery pack.
6. Referring to Figure 3-9 overleaf, set the four Frequency Channel Selector Switches to select the Channel Address Number previously noted in step 2., above.
7. Replace the battery pack in the unit, making sure the contacts on the underside of the battery pack locate with their corresponding pick-up contacts in the battery tray. Close the battery door and secure by pressing firmly until it snaps into the locked position.
8. Set the controller’s Power ON/OFF Switch(es) to ‘ON’. Observe that the TRANSMIT/LOW BATTERY LED momentarily flashes yellow and two quick beeps are heard.
9. Operate a **non-motion function** such as a horn or light on the target equipment using the appropriate toggle switch and observe the TRANSMIT/LOW BATTERY LED and the selected horn or light. If the LED flashes green and the horn or light activates, your controller is fully operational.

Pre-programmed Frequency Selection, continued.

Figure 3-9. Pre-programmed Frequency Selection

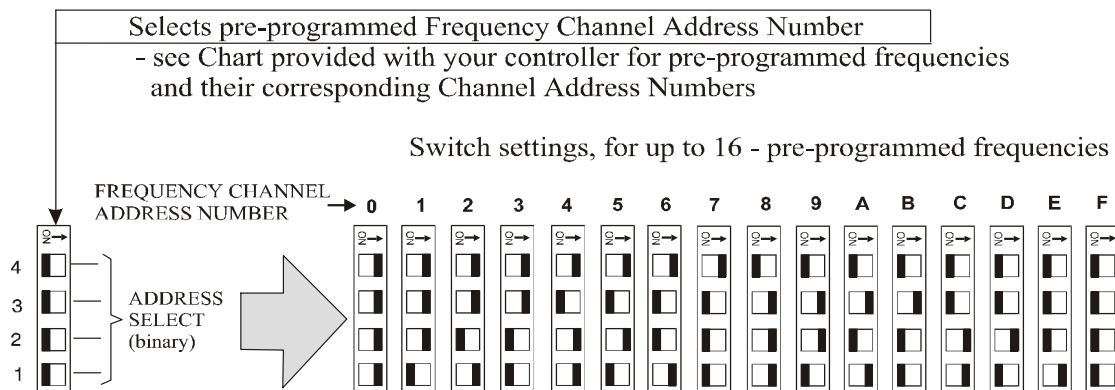
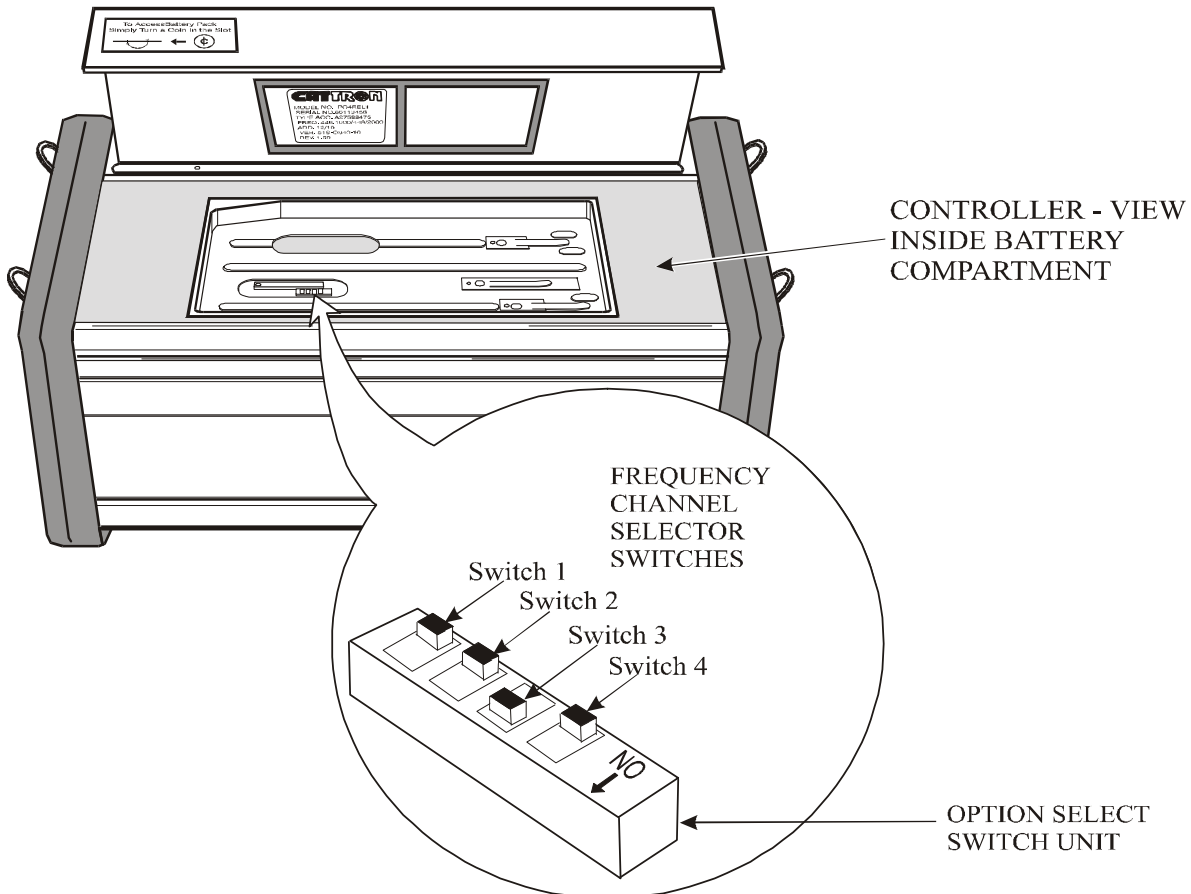



Pre-programmed Option Selection.

Because each paddle controller has been designed and custom built for a specific remote control application, the OPTION SELECT SWITCH UNIT (refer to Figure 3-9, opposite) may have been pre-configured with one of three discrete programming options. It should be noted that the exact switch configuration will depend upon the firmware selected by your CATTRON-THEIMEG™ Applications Engineer at the time your PRRC system was designed. When applicable, a programming option may be selected from one of the following:

1. Up to 16 frequency only select (factory programmed) – refer to **‘Pre-programmed Frequency Selection’** in this Section for complete details.
2. 4-frequency select (factory programmed).
3. Up to 16 selection options - each position may be factory programmed with one of the following:
 - a) Transmit frequency
 - b) Transmit address
 - c) Timesharing pattern

Refer to the specific information in the custom engineered drawing package provided with your controller to determine the exact configuration of the OPTION SELECT SWITCH UNIT and the pre-programmed option (if any). When applicable to your controller, specific switch selections for a given pre-programmed option will be provided.

END OF SECTION



This page intentionally left blank



Section 4 – Maintenance Instructions

CATTRON-THEIMEG™ Maintenance Philosophy.

Our maintenance philosophy is that inoperative Paddle Controllers are returned as complete units to our workshops for repair. This is because (a) each controller is customized for a specific control application which severely restricts component/part interchangeability, (b) the internal circuit board and microprocessor is extremely sensitive to electrostatic discharge, and (c) internal components are highly miniaturized and assembled to within very close tolerances. However, CATTRON-THEIMEG™ will permit certain preventive and corrective maintenance to be performed without voiding our warranty, as follows:

Preventive Maintenance is a periodic check of the system to keep it functioning at peak performance. Preventive maintenance can also help prevent breakdowns and equipment outages by identifying potential problems before they become real problems.

Corrective Maintenance refers to fixing a problem once it has occurred. The goal of corrective maintenance is to get the system back on line as quickly as possible with a minimum impact on operations.

Preventive maintenance.

Preventive maintenance for CATTRON-THEIMEG™ Paddle Controllers is minimal because they are extremely durable and reliable units. Preventive maintenance procedures are detailed in the following sub paragraphs:

Daily Visual Inspection.

Before use, visually inspect the controller for cleanliness, physical damage, and security of external parts (screws, switches, rubber grips, etc.). CATTRON-THEIMEG™ emphasizes that regular visual inspections not only mean quickly locating a source of potential problems, but also may prevent serious problems from developing later.

Special RF Test (CATTRON-THEIMEG™ trained technicians only).

The special RF test mode is a diagnostic mode that is incorporated in your Paddle Controller. Controller outputs can be monitored on a spectrum analyzer/communication service monitor set to the same frequency as the controller. We emphasize this procedure is **only** for use by customer technicians that have been trained by ourselves where further details are presented during the CATTRON-THEIMEG™ training course. For information purposes, the actual RF test procedure is summarized on the next page:



Special RF Test, continued.

With PTO Bar switch depressed, setting the ON/OFF KEYSWITCH to 'ON' will transmit a continuous beep and the green LED will illuminate continuously. Continually cycling (pressing and releasing) the PTO bar switch three times will initiate the RF diagnostic sequence (the beep will stop). Further PTO bar switch cycling will make the controller transmit the following:

CYCLE	CONTROLLER TRANSMISSION
4	Maximum Low Frequency (a frequency 2.4 kHz lower than carrier)
5	Q- Sync (center of carrier)
6	Maximum High Frequency (a frequency 2.4 kHz higher than carrier)
7	2 kHz modulating sine wave (tone)
8	1-2-2-1 pattern square wave

Annual Netting Check.

Netting means that the receiver and transmitter of the radio control system are aligned on the same frequency. It is very important that the receiver is exactly tuned to the frequency required. This check should be done **once a year by a qualified radio technician utilizing calibrated test equipment.**

Troubleshooting.

A basic Troubleshooting Guide is provided on page 3 of this section. For safety reasons, when troubleshooting the Paddle controller, the power supply to the target equipment motors and all motion functions must be completely isolated to prevent operation under remote control. However, the other major components of the remote control system (power supply and receiver/decoder) should be fully operational. The remote control operator should also be located within 500 feet (160+ meters) of the target receiver/decoder.

Troubleshooting Guide.

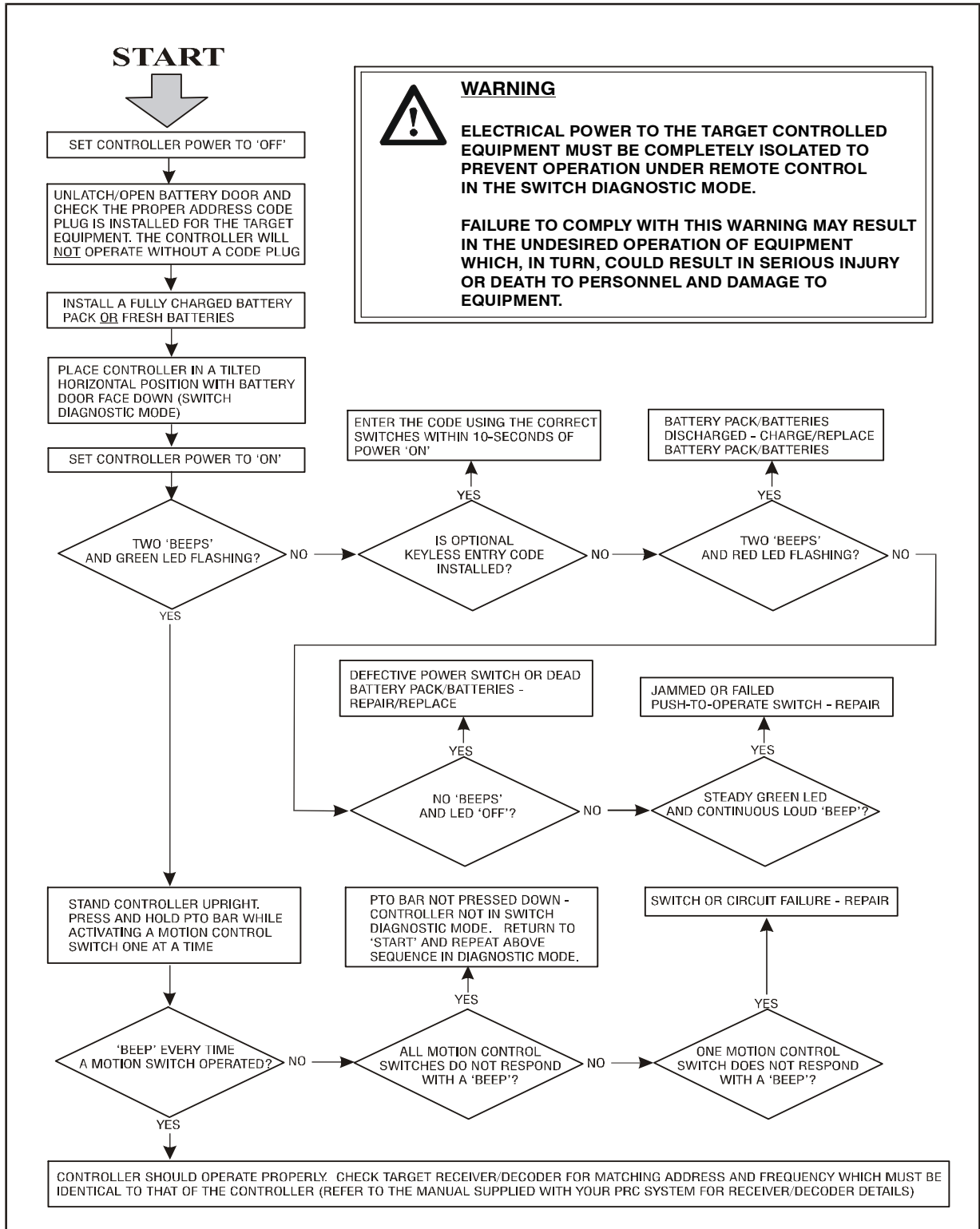



Corrective maintenance.

Corrective maintenance for the Paddle Controller is restricted to replacing the Battery Pack, Address Code Plug, Paddle Levers and, when installed, the External Antenna. Refer to the **Replacement Procedures** below when removing and replacing items. Having replaced an item, and before placing the Paddle Controller into operational service, carry out a Functional Check as follows:

Functional Check.

1. Set the controller's Power ON/OFF Switch(es) to 'ON'. Observe that the TRANSMIT/LOW BATTERY LED momentarily flashes yellow and two quick 'beeps' are heard.
2. Operate a **non-motion function** such as a horn or light on the target equipment using the appropriate toggle switch and observe the TRANSMIT/LOW BATTERY LED which should flash green.
3. Set the controller's Power ON/OFF Switch(es) to 'OFF'.
4. Operate the controller in **Switch Diagnostic Mode** (refer to Section 3 for procedure), insuring all toggle, pushbutton, and paddle lever function switches are fully operational.

Replacement Items.

Replacement items and accessories for your controller may be ordered direct from CATTRON-THEIMEG™. To order replacement items, refer to Section 5 of this manual for details and part numbers.

Replacement Procedures.

Battery Pack Replacement.

To replace the battery pack, proceed as follows:

1. Set the controller's Power ON/OFF Switch(es) to 'OFF'.
2. Referring to Figure 4-1 opposite, unlock the battery door by inserting a coin into the slot and twisting.
3. Open the battery door and lift the battery pack out of the tray.
4. Install a fresh or fully charged battery pack in the unit, making sure the contacts on the underside of the battery pack locate with their corresponding pick-up contacts in the battery tray.
5. Close the battery door and secure by pressing firmly until it snaps into the locked position.
6. Carry out a **Functional Check** on the controller – refer to the above paragraph for details.

Battery Pack Replacement, continued.

Figure 4-1. Battery Pack Replacement.

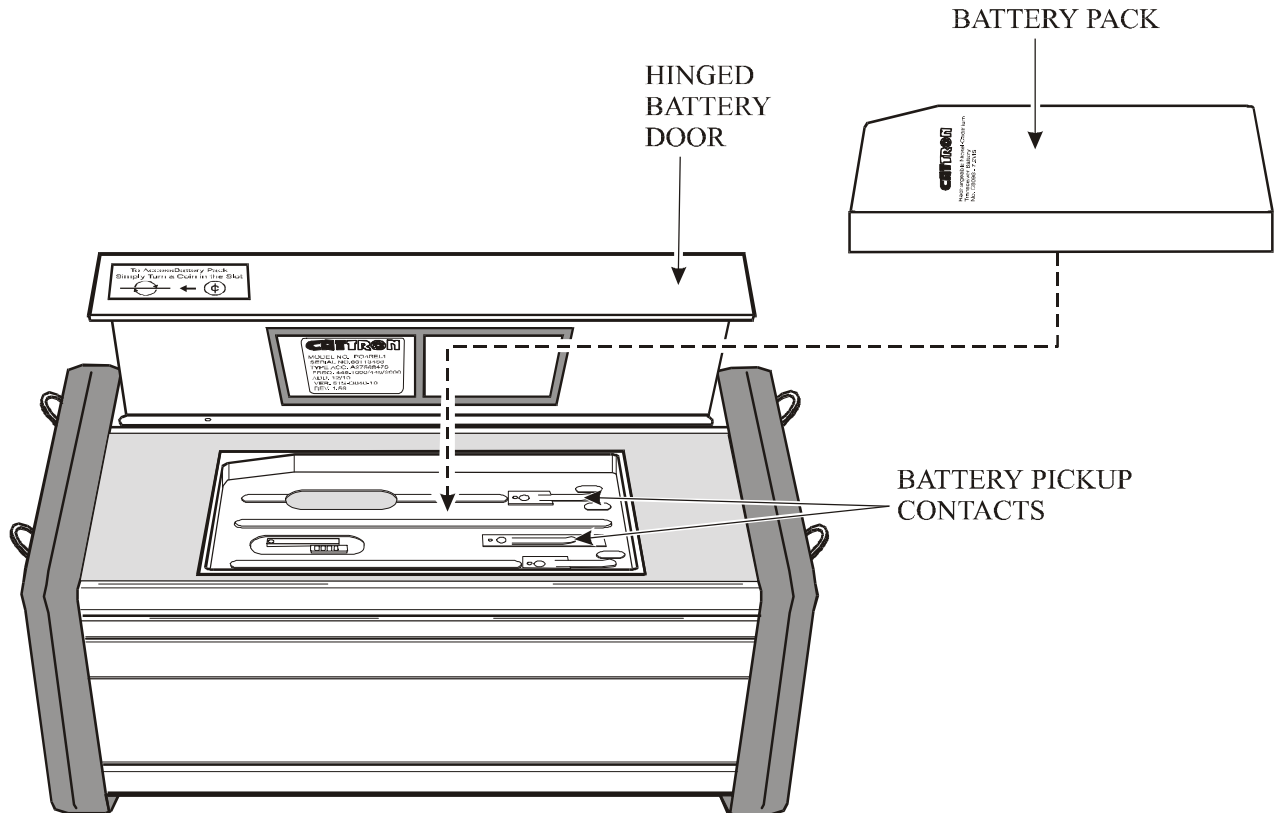

Address Code Plug Replacement.

Each CATTRON-THEIMEG™ Paddle Controller is equipped with a code plug. This code plug sets the address of the controller which should always match the address of the target receiver/decoder. When a command is received by the receiver/decoder, the address of the controller sending the signal is checked against the address of the receiver/decoder. If the addresses do not match, the signal is ignored and an error message is displayed on the receiver/decoder. For safety reasons, it is important that no two controllers at a location use the same address settings. This could cause operation of undesired equipment resulting in damage to equipment and/or personal injury.

While the factory address setting will be adequate for most users, there may be conditions where it is necessary to change the address code. Such conditions include the use of a spare controller, or when your controller will be used to operate more than one crane, locomotive, or controlled machine. Before making any change in the address code setting, you will be required to identify the address code of the target receiver/decoder.

The code assigned to the receiver/decoder at the factory is found on a serial tag located inside the target receiver/decoder. For information on setting the address code for your receiver/decoder, refer to the documentation provided with the receiver/decoder.



Address Code Plug Replacement, continued.



WARNINGS:

UNCODED ADDRESS PLUG(S) SHALL BE PROGRAMMED WITH THE SAME ADDRESS CODE AS SET IN THE TARGET RECEIVER/DECODER. IT SHOULD BE FULLY UNDERSTOOD THAT CATTRON-THEIMEG™ SHALL NOT BE HELD LIABLE FOR PERSONAL INJURY, DEATH, EQUIPMENT OR PROPERTY DAMAGE ARISING FROM DUPLICATED, INCORRECTLY PROGRAMMED OR INCORRECT CODE PLUG USAGE.

IT IS YOUR RESPONSIBILITY TO ESTABLISH A PROCEDURE THAT INSURES ONLY THE CODE PLUG CONFIGURED FOR A PARTICULAR ADDRESS IS INSTALLED IN EQUIPMENT DESIGNED TO OPERATE ON THE SAME ADDRESS. NEVER PUT MORE THAN ONE CONTROLLER INTO OPERATION ON THE SAME ADDRESS AT ANY GIVEN TIME. CATTRON-THEIMEG™ STRONGLY ADVISES YOU TO IMPLEMENT AND REGULARLY UPDATE A REGISTER OF INDIVIDUAL ADDRESSES AND OPERATING FREQUENCIES ASSIGNED TO EACH PORTABLE RADIO REMOTE CONTROL (PRRC) SYSTEM LOCATED AT YOUR OPERATING FACILITY. IN ADDITION, ANY SPARE CODE PLUGS, OR CODE PLUGS INSTALLED IN EQUIPMENT THAT ARE CONFIGURED FOR THE SAME ADDRESS OF EQUIPMENT THAT IS IN SERVICE, MUST BE HELD UNDER LOCK AND KEY BY A DESIGNATED SUPERVISOR.

FAILURE TO COMPLY WITH THESE WARNINGS MAY RESULT IN OPERATION OF UNDESIRED EQUIPMENT WHICH IN TURN COULD RESULT IN PERSONAL INJURY OR DEATH TO PERSONNEL AND DAMAGE TO EQUIPMENT.

CATTRON-THEIMEG™ sets the address code of all paddle controllers before they leave the factory. If the code must be changed, a new code plug with the new address code must be obtained from CATTRON-THEIMEG™. In some circumstances CATTRON-THEIMEG™ may provide blank, or unset, code plugs. An unset code plug must have a code set prior to installing in the decoder. This is described in the procedure below. Installing an unset code plug in the controller will prevent the controller from operating.

To replace the code plug for your Paddle Controller, proceed as follows:

1. Set the controller's Power ON/OFF Switch(es) to 'OFF'.
2. Record the address code of the intended equipment to be controlled – this may be found on the front cover of the manual provided with the target receiver/decoder, or on a serial tag located inside the target receiver/decoder enclosure.
3. Referring to Figure 4-1 above, unlock the battery door by inserting a coin into the slot and twisting.
4. Open the battery door and lift the battery pack out of the tray.

Address Code Plug Replacement, continued.

- Referring to Figure 4-2 below, using a pair of small flat nosed pliers, remove the existing 'set' code plug by pulling it straight up and away from its battery compartment location. We recommend you: (1) tag the removed code plug with the serial number of the controller, and (2) deposit the code plug in a safe place under lock and key.

Figure 4-2. Code Plug Location.

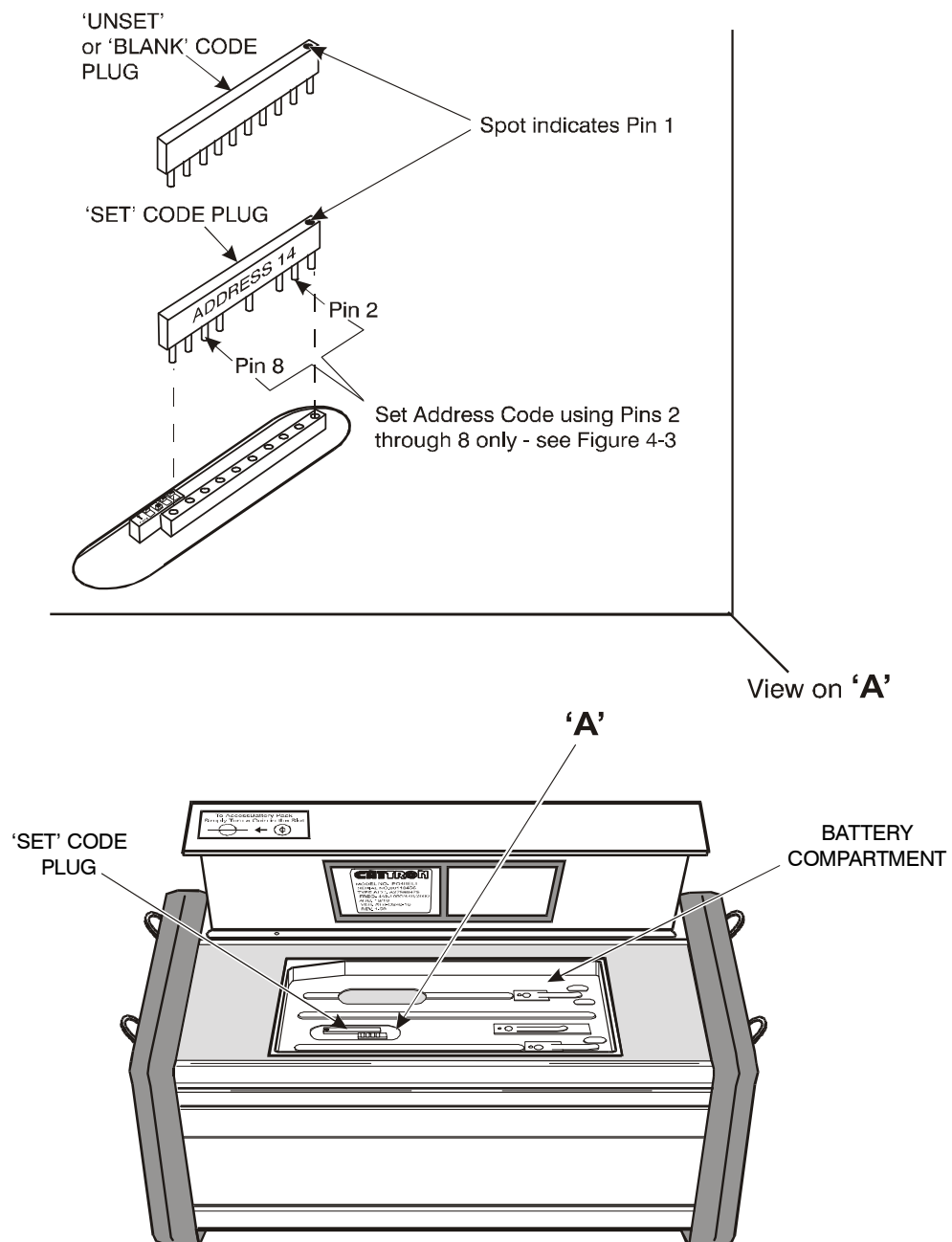

Address Code Plug Replacement, continued.

- If the new code plug is blank (unset), set the new address code previously recorded in Step 2. To set the code, pins 2 through 8 must be cut in a specific pattern. Figure 4-3 below shows all possible address codes for the code plug. For example, to set the code plug to Address Code 14, pins 4, and 6 must be cut. DO NOT cut Pins 1, 9 and 10.

Figure 4-3. Code plug settings.

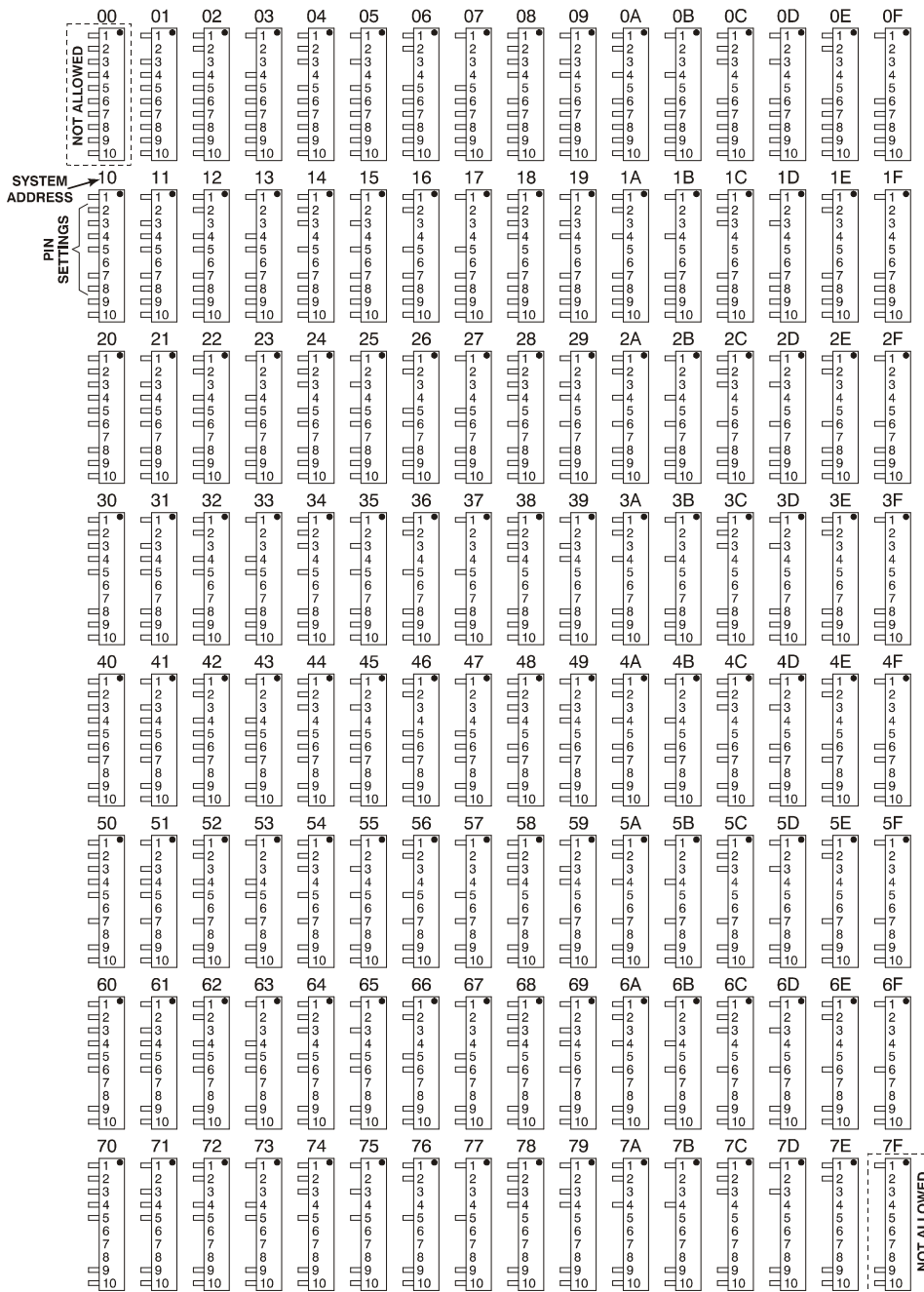

Address Code Plug Replacement, continued.

7. Write the newly set address code on the side of the code plug using a permanent marker.
8. Carefully install the new code plug, making sure the spot (Pin 1) is positioned as shown in Figure 4-2, above.
9. Referring to Figure 4-1 above, replace the battery pack in the unit, making sure the contacts on the underside of the battery pack locate with their corresponding pick-up contacts in the battery tray.
10. Close the battery door and secure by pressing firmly until it snaps into the locked position.
11. Carry out a **Functional Check** on the controller – refer to page 4 of this Section for details.

Paddle Lever Replacement, (Figure 4-4).

1. To replace a Paddle Lever, remove Screw (1) using a 6/32" hexagonal key and withdraw Lever (2) from Shaft (3).
2. Install a new Lever (2) to the Shaft (3) and secure using Screw (1).

Figure 4-4. Lever Replacement.

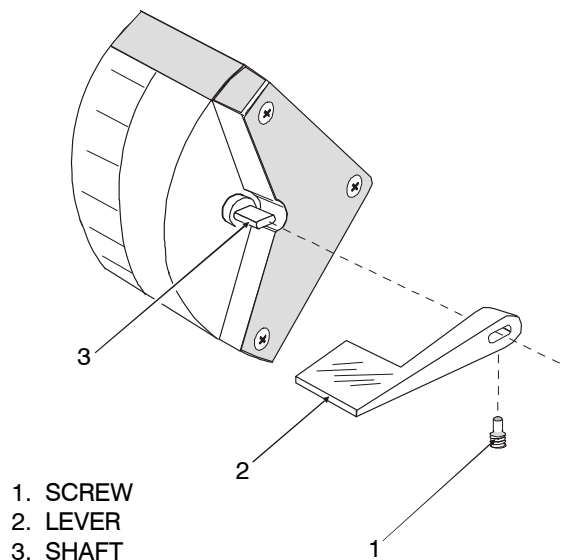

External Antenna Replacement, (Figure 4-5).

1. Remove the External Antenna (1) by pushing down and unscrewing the BNC connector (2) half-a-turn in a counter-clockwise direction from its connector socket (3) located on the lower front plate of the controller.
2. The new Antenna (1) is simply installed by screwing the BNC connector (2) clockwise until it 'clicks' into the connector socket (3) located on the lower front plate of the controller.

External Antenna Replacement, continued.

Figure 4-5. External Antenna Replacement.

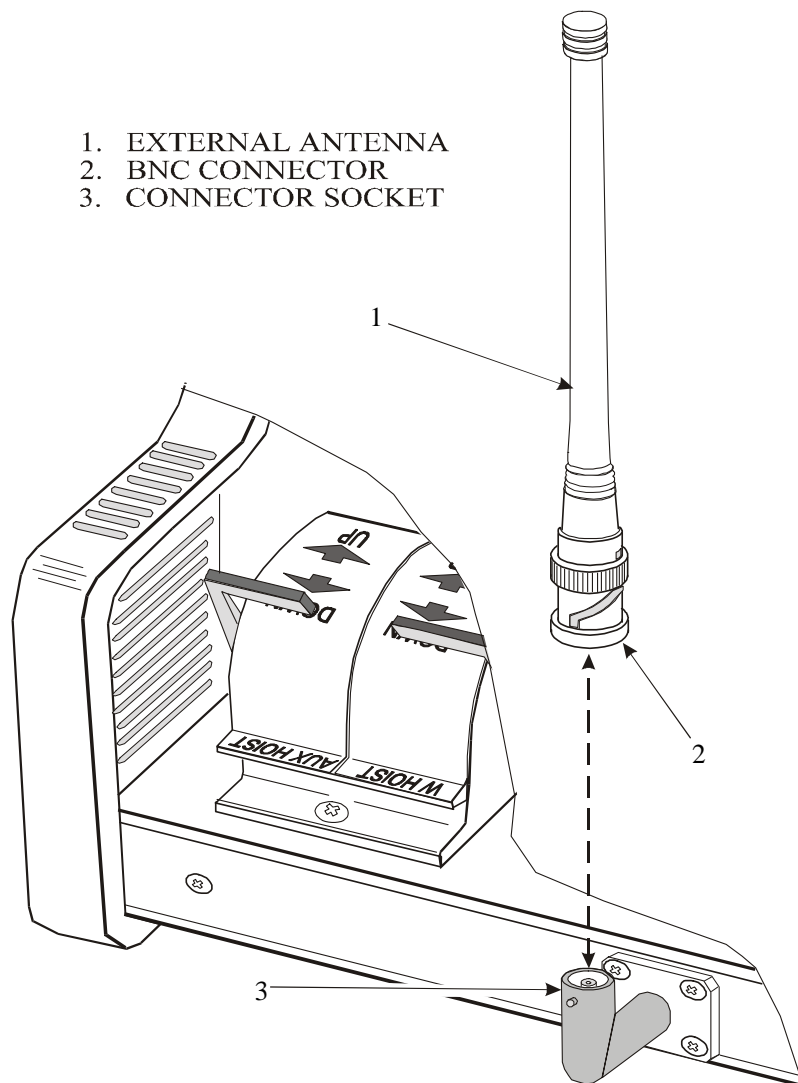

END OF SECTION



Section 5 – Replacement Items and Accessories

Notable differences between Paddle Controllers will include the *quantity*, *type*, and *placement* of toggle, paddle, and pushbutton switches. **For an individual controller’s exact switch and indicator configuration, including quantities and part numbers, you should refer to the schematic drawing originally supplied with the paddle controller.**

Note: Replacement items identified in Figure 5-1 overleaf should only be installed by approved customer technicians who have attended the CATTRON-THEIMEG™ Technician Training Course.

Referring to the illustration overleaf (Figure 5-1):

- Two types of Pushbutton Switch Assemblies are available - cross refer to Table 5-1 below
- Toggle Switch Assemblies are supplied in a variety of configurations - cross refer to Table 5-2 below.
- Items 1 through 29 are common to most paddle controllers - cross refer to Table 5-3.

Table 5-1. Pushbutton Switch Assemblies

COMPONENT DESCRIPTION	CATTRON-THEIMEG™ PART NUMBER
RED PUSHBUTTON	40C-0308
GRAY PUSHBUTTON	40C-0308GRY

Table 5-2. Toggle Switch Assemblies

COMPONENT DESCRIPTION	SWITCH BODY* IDENTIFIER	CATTRON-THEIMEG™ PART NUMBER
ON-OFF-ON	12TW1-1	40C-0112
ON-OFF-ON LKG.	12TW1-1A	40C-0356
ON-OFF	12TW1-3	40C-0005
ON-OFF LKG.	12TW1-3D	40C-0337
ON-OFF-(ON)	12TW1-5	40C-0113
ON-OFF-(LIFT ON)	12TW1-5N	40C-0315
(ON) OFF (ON)	12TW1-7	40C-0111
(LIFT ON) OFF (LIFT ON)	12TW1-7E	40C-0347
OFF (ON)	12TW1-8	40C-0170
OFF (LIFT ON)	12TW1-8F	40C-0303

* The identifier number is engraved on the switch body

Figure 5-1. Exploded View

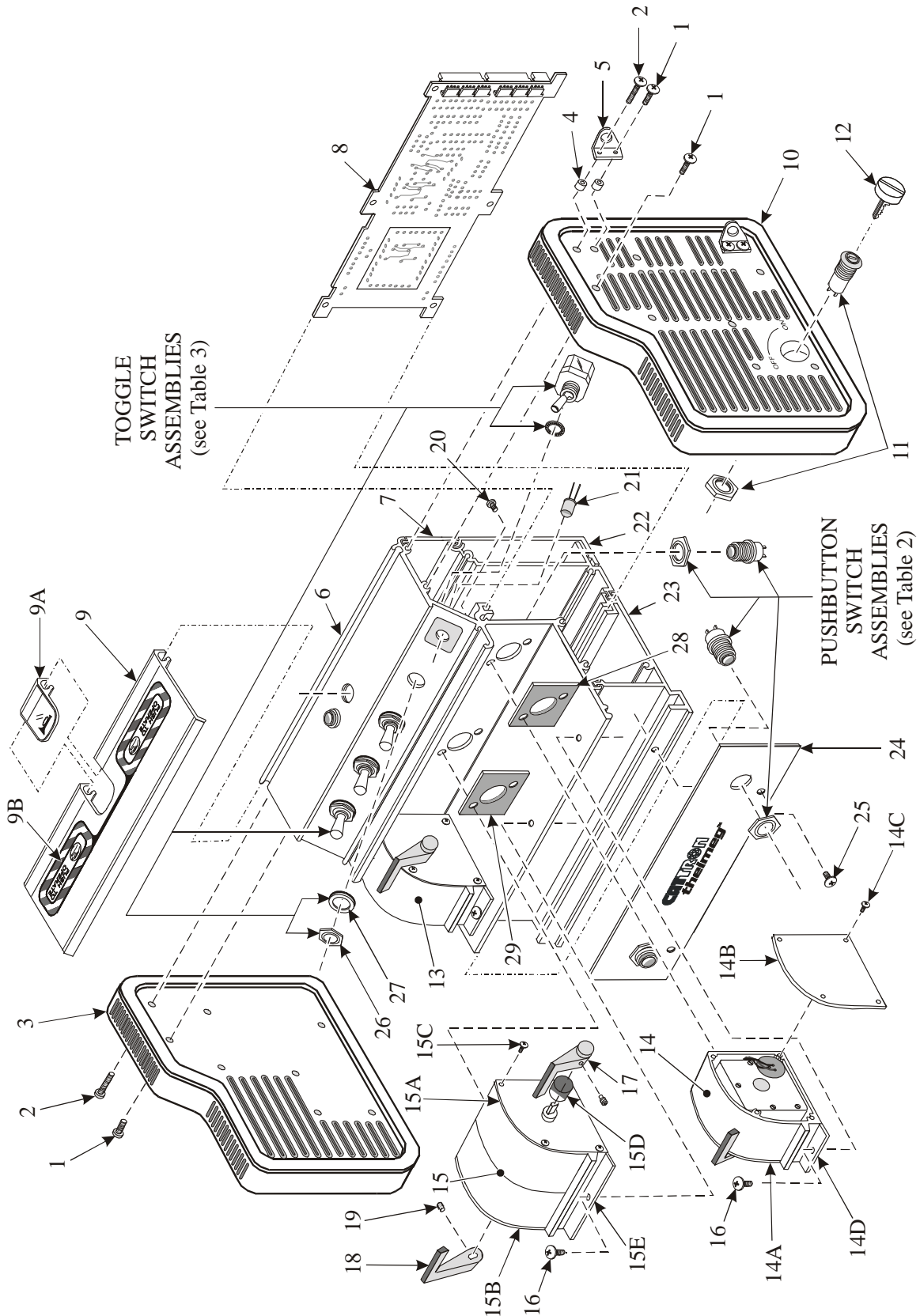



Table 5-3. Common items

FIGURE 5-1, ITEM NUMBER	COMPONENT DESCRIPTION	QUANTITY PER ASSEMBLY	CATTRON-THEIMEG™ PART NUMBER
1	Screw, Truss Head, Phillips, 8-32 x 5/8"	20	03C-0094
2	Screw, Truss Head, Phillips, 8-32 x 1"	2	03C-0099
3	RH Endcap Assembly, with Sonalert	1	01C-0126
-	... Gasket, RH Endcap	1	32C-0092R
4	Washer/Spacer	8	04C-0027
5	Bracket Ring for carrying harness	4	07-83585B01
6	Front Housing, 3-Motor	1	15C-0115F
-	Front Housing, 4-Motor*	1	15C-0115F4
7	Battery Housing, complete	1	01C-0115R-01
8	Encoder Board**	1	E840/M840P Series
9	PTO Bar Assembly, c/w Tab & Label	1	01C-0276WA-01
9A	... Tab, PTO	1	15C-0114A-01
9B	... Label	1	54C-0107WA
10	LH Endcap Assembly	1	01C-0125
-	... Gasket, LH Endcap	1	32C-0092L
11	Switch, Keylock with Keynob and wires	1	01C-40C-0369K
12	Key, complete with Hexagonal Knob	1	55C-0369K
13	Lever Switch Assembly RH	As Required	CPA-0274
14	Lever Switch Assembly LH	As Required	CPA-0275
14A	... LH Side Plate, c/w Standoff	1	15C-0057
14B	... Side Plate, Blank, RH or LH	1	15C-0059
14C	... Screw, Truss Hd, Phillips, 4-40 x 3/8"	4	03C-0096
14D	... Housing, Single	1	15C-01125S
15	Lever Switch Assembly, Dual	As Required	CPA-0276
15A	... RH Side Plate, c/w Standoff	1	15C-0058
15B	... LH Side Plate, c/w Standoff	1	15C-0057
15C	... Screw, Flat Hd, Phillips, 4-40 x 3/8"	4	03C-0096
15D	... Gear Cap	1	15C-135-3274
15E	... Housing, Dual	1	15C-0112D
16	Screw, Truss Head, Phillips, 6-32 x 3/8"	As Required	03C-0095



Table 5-3. Common items, continued

FIGURE 5-1, ITEM NUMBER	COMPONENT DESCRIPTION	QUANTITY PER ASSEMBLY	CATTRON-THEIMEG™ PART NUMBER
17	Lever, Left Hand	As Required	36-83735D03-LEX
18	Lever, Right Hand	As Required	36-83735D01-LEX
19	Screw, Hex, Set, 6-32 x 0.5", SS, Lever	As Required	03-83641C01
20	Screw, Truss Head, Phillips, 6-32 x 1/4"	As Required	03C-0100
21	LED, Non-diffused, Red/Green	1	40C-0227
22	Battery Cover, with Gasket	1	01C-0278-01
23	Bottom Housing, 3 & 4-Paddle	1	15C-0115B
24	Antenna, 402-470MHz**	1	CAE-6007SYN
25	Screw, Truss Head, Phillips, 4-40 x 1/4"	2	03C-0098
26	Nut, Hex, Encl Top, 15-32	As Required	02C-0011
27	Washer, Sealing, 15/32-32, Switch Panel	As Required	04C-0047
28	Gasket, Single	As Required	32C-0032
29	Gasket, Dual	As Required	32C-0033

* Alternative

** see schematic drawing originally supplied with controller for correct part number.



Consumable Items and Optional Accessories.

Consumable Items and Optional Accessories are listed in Table 5-4 below and illustrated on the following pages.

Table 5-4. Consumable Items and Optional Accessories

Item Number	CATTRON-THEIMEG™ Part Number	Order Quantity	Item Description
1	60C-0023	1	Battery pack, Alkaline, 12.5V, non-rechargeable
2	C-8096	1	Battery pack, Ni-Cad, re-chargeable, 12.5V, 850 mAH
3	70C-0004	1	Battery Conditioner, 100-240 VAC input
4	CLN-6095	1	Carrying Harness, Standard, small
*	CLN-6096	-	Carrying Harness, Standard, large
*	CLN-6096XL	-	Carrying Harness, Standard, extra large
5	CLN-300901XS	1	Carrying Harness, Low Back Support, extra small
*	CLN-300902S	-	Carrying Harness, Low Back Support, small
*	CLN-300903M	-	Carrying Harness, Low Back Support, medium
*	CLN-300904L	-	Carrying Harness, Low Back Support, large
*	CLN-300905XL	-	Carrying Harness, Low Back Support, extra large
*	CLN-300906XXL	-	Carrying Harness, Low Back Support, double extra large
*	CLN-300907XXXL	-	Carrying Harness, Low Back Support, triple extra large
6	06C-0232	1	Code Plug, Unprogrammed
7	06C-0232P	1	Code Plug, Programmed
8	36C-0066	1	Custom Lever, Right Hand, Blank, threaded
9	36C-0067	1	Custom Lever, Left Hand, Blank, threaded
10	36C-0073-O	1	Knob, Oval, for Items 8 and 9 above
11	36C-0073-S	1	Knob, Square, for Items 8 and 9 above
12	36C-0073-C	1	Knob, Cylindrical, for Items 8 and 9 above
13	36C-0073-H	1	Knob, Hexagonal, for Items 8 and 9 above

* = alternative



Consumable Items and Optional Accessories, continued.

Item 1 – Part Number 60C-0023

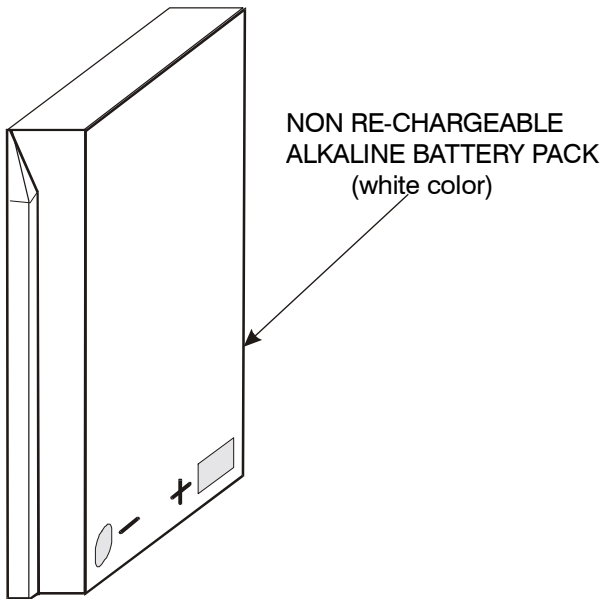

Item 2 – Part Number C-8096

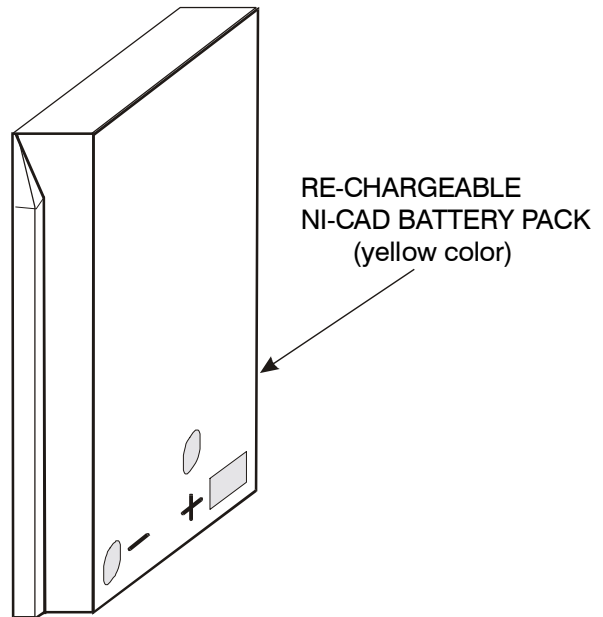

Item 3 – Part Number 70C-0004

BATTERY PACK CONDITIONER
PART NUMBER 70C-0004

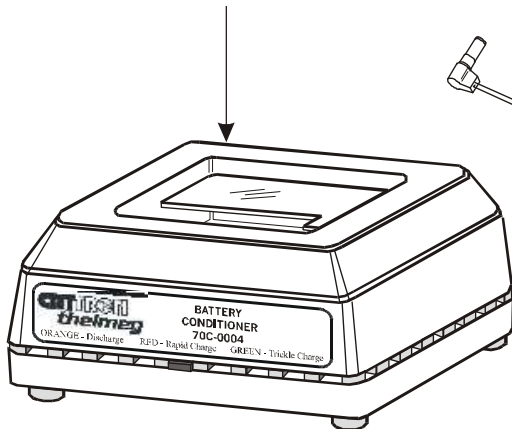

MULTI-VOLTAGE ADAPTER

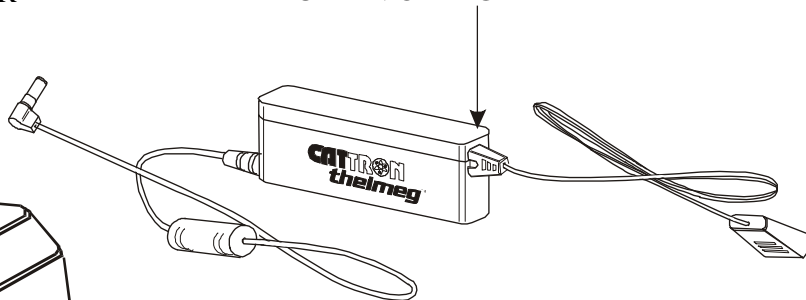

Consumable Items and Optional Accessories, continued.

Item 4 – Part Number CLN-609Series

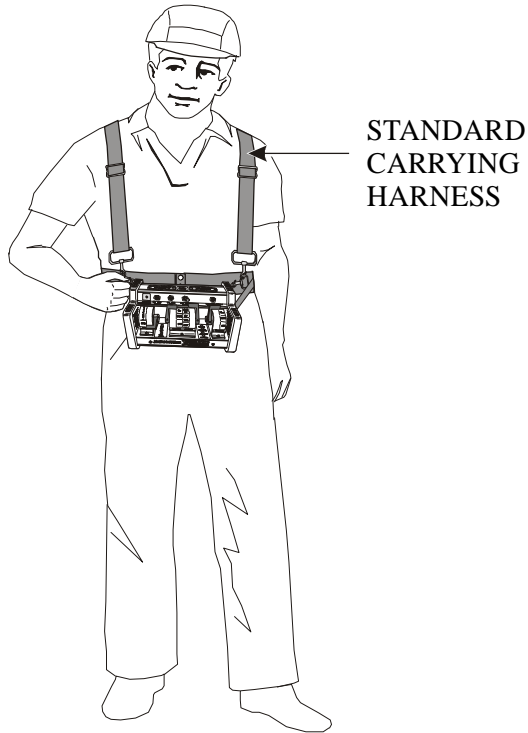

Standard Carrying Harnesses are available in 2 sizes as follows:

Part #	Size	To Fit Waist Sizes
CLN-6096	Small to Large	37.5 - 56 inches
CLN-6096XL	Extra Large	48 - 68 inches

Item 5 – Part Number CLN-3009Series



Low Back Support Carrying Harnesses are available as follows:

Part #	Size	To Fit Waist Sizes
CLN-300901XS	Extra Small	28 - 32 inches
CLN-300902S	Small	32 - 36 inches
CLN-300903M	Medium	36 - 40 inches
CLN-300904L	Large	40 - 44 inches
CLN-300905XL	Extra Large	44 - 48 inches
CLN-300906XXL	Double Extra Large	48 - 52 inches
CLN-300907XXXL	Triple Extra Large	52 - 56 inches

Item 6 – Part Number 06C-0232

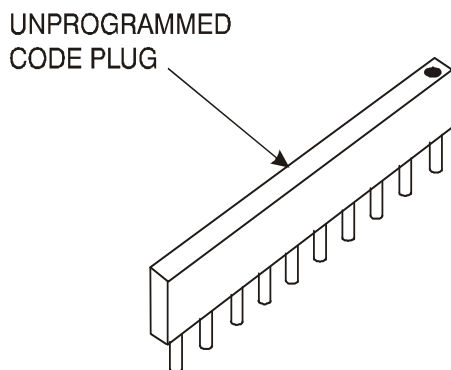

Item 7 – Part Number 06C-0232P

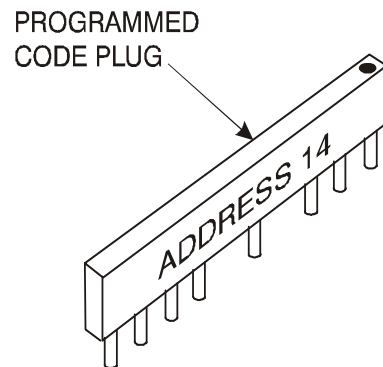

Consumable Items and Optional Accessories, continued.

Item 8 – Part Number 36C-0066

CUSTOM RIGHT
HAND LEVER

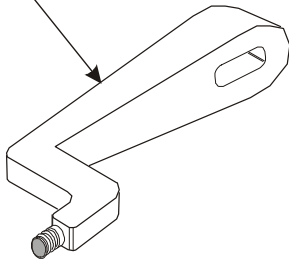

Item 9 – Part Number 36C-0067

CUSTOM LEFT
HAND LEVER

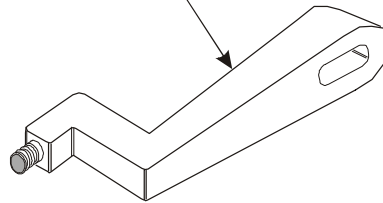

Item 10 – Part Number 36C-0073-O

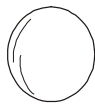

OVAL
KNOB

Item 11 – Part Number 36C-0073-S

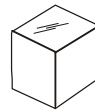

SQUARE
KNOB

Item 12 – Part Number 36C-0073-C



CYLINDRICAL
KNOB

Item 13 – Part Number 36C-0073-H

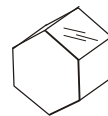

HEXAGONAL
KNOB

END OF SECTION

A

Accessories 5-5
 Address code 2-1
 Applications 1-3
 Automatic safety override 2-1

B

Battery Pack Conditioner 3-18, 5-2
 Battery door 3-18
 Battery pack conditioning 3-20
 Battery pack options 1-2, 3-18
 Battery pack replacement..... 3-18, 4-4
 Battery Saver 1-2

C

Carrying harnesses 3-5 - 3-7
 Code plug replacement 4-5
 Controls and indicators 3-1
 Corrective maintenance 4-4
 Crane Control Functions (typical) ... 3-10
 Custom paddle levers & knobs 5-7

D

Data error checking 2-2

F

Frequency options 1-3
 Frequency selection 3-22
 Frequently asked questions 1-3
 Functional check 4-4

G

General operating procedure 3-5

I

Intelligent digital message protocol 2-1

L

Lever switch placement 1-2
 Lever replacement 4-9
 List of abbreviations iii
 Locomotive Control Functions 3-13

M

Maintenance instructions 4-1
 Maintenance philosophy 4-1

N

Netting check 4-2
 Notable performance & safety
 Features 1-2

O

Operate (OPR) relay 2-1
 Operating frequency 1-3
 Operating instructions 3-1
 Optional accessories 5-3
 Overview, remote control systems .. 1-7



Index

P		S		
	Paddle switch placement	1-2	Safety considerations	2-1
	Power On Self Test (POST)	1-2	Safety & security features	2-1
	Power ON/OFF switch	3-1, 3-2	Side mounted levers	1-2, 3-2
	Preventive maintenance	4-2	Standard specifications	1-5
	Push To Operate bar switch	2-2, 3-2	Switches	3-2, 3-3
R			Switch diagnostic mode	3-17
	Radio control operator's duties:	T		
	General Equipment		TALKBACK™ option	3-3
	EOT Crane		Technical Abbreviations	iii
	Locomotive		Transmit/Low Battery indicator	3-3
	Replacement items		Troubleshooting guide	4-3
	Replacements:		Typical method of operation	2-2
	Battery pack			
	Address code plug			
	Paddle lever			
	External Antenna			



RECOMMENDED SAFETY RULES FOR PORTABLE REMOTE CONTROLLED (PRC) CRANES

For the purpose of these rules, Portable Remote Control or PRC refers to Radio Frequency (RF) Controls. The information contained herein is based on data gathered from various users of portable remote control crane systems. **We emphasize that the recommendations contained herein are not intended to supersede the rules or regulations of our customers, or the rules and regulations of any applicable local, state, or federal government organizations. It must be fully understood that the recommendations contained herein are provided solely for your consideration and possible adoption.**

TABLE OF CONTENTS

SECTION	TITLE	PAGE
1	Preface	1
2	Operator Safety Basics	2
2-1	Area Inspection	2
2-2	Crane Inspection (mechanical & structural)	2
2-3	Operational Safety Check	3
3	Persons Authorized to Operate Remote Controlled cranes	3
4	Training Check List for Operation of Remote Controlled cranes	3
5	Operating Area for Remote Controlled Cranes	4
6	The Hand-held Portable Remote Controller	4
7	Operating the Remote Controlled Crane	5
8	Boarding the Remote Controlled Crane	6
9	On Board the Remote Controlled Crane	6
10	Remote Controlled Crane under Repair	7
11	The Condition of the Remote Controlled Crane	8

1. PREFACE.

- 1-1. Electric Overhead Traveling (EOT) Cranes typically operate in three motions. They are large, bulky pieces of equipment that handle heavy loads efficiently at comparatively high speeds. Frequently, they are operated in restricted areas where workmen are engaged in various tasks on the floor below. Under these conditions crane operators using Portable Remote Control (PRC) must take great care, and workmen must be constantly on the alert if accidents are to be avoided.
- 1-2. The following guidelines have been carefully assembled and are promoted to indicate just how important your careful and thoughtful actions are in helping to protect you and your fellow workers from harm, and also to prevent equipment damage.
- 1-3. These guidelines cover cranes when they are operational in Portable Remote Control (PRC) mode by Radio Frequency. If a crane is operated from cab or pendant control, the PRC system's controller(s) should be completely isolated by removing the battery and held under lock and key.
- 1-4. A routine pre-shift inspection of the crane takes a lot less time than repairing a crane suffering from a major problem. In addition, such pre-shift inspections are to be considered as 'safety basics' which are an important part of a crane operator's duties.



2. **OPERATOR SAFETY BASICS.** Before starting your shift as the crane operator, you should make sure the crane has a current inspection certificate and that qualified personnel have carried out the following inspections and checks. If any item below does not pass inspection, you should notify your supervisor immediately. In many cases, the problem will need to be fixed before you are allowed to operate the crane. In addition, did you realize that the person now reading these instructions is primarily responsible for his or her own health and safety?

2-1 **Area Inspection.**

- Take a good look around the work area for any obstructions.
- Check that the rails are intact and not bent or damaged.
- Make sure there are no oil or brake fluid leaks on the area below where the crane travels.
- Make sure rail stops are present, physically secure, and free of damage at the end of all crane rails.
- Check that walkways are sturdy and have handrails. Ladders are not to be loose and all rungs are to be in place.

2-2. **Crane Inspection** (mechanical & structural).

- Make sure all moving machinery has protective guards installed over moving parts.
- Make sure all bridge and trolley rail stops are welded or bolted in position with no evidence of damage from bridge or trolley impact.
- Check for proper fluid levels and make sure all grease fittings are lubricated to manufacturer recommendations.
- Check for broken welds and cracks in the bridge structure.
- Check for wheel damage, broken welds on the frame, and drum damage.
- Check the wheels for flange wear, cracks, holes, or visible signs of bearing damage.
- Make sure wire rope drums show proper wire rope lay; for example, each wire rope must lay in its own groove. This does not mean in the non-grooved area in the center of the drum.
- Make sure wire rope size is correct for the sheaves. Look for either oversized or undersized rope that will not lay in the sheaves correctly. Make sure the sheaves show no evidence of rope corrugation and have the proper wall thickness.
- Look for any type of bluing on the brake drums which indicates excessive heat. Make sure there are no protruding rivets from the brake shoes. Examine the shoes for glazing.
- Look for carbon dust around the inspection covers of electric motors. Smell for any type of burning smells. Check for any type of burning on electrical covers. Make sure all protective covers are installed.
- Check the festoon system for proper connections and inspect all hooks connecting the festoon to the holding wire.
- Load bearing parts such as blocks and hooks shall have no signs of damage and be in perfect working order.



2-3. **Operational Safety Check.** As a crane operator, you should satisfy yourself of the following. If any item below does not meet the checklist criteria, you shall immediately notify your supervisor. In many cases, the problem will need to be fixed before you are allowed to operate the crane. Remember that the person now reading these instructions is primarily responsible for his or her own health and safety!

- Horns, buzzers and all other warning devices shall be in working order.
- All controls shall be in good working order.
- STOP Buttons (when equipped) shall be in working order.
- The load brakes shall hold the load safely at all times. The only way to ensure this is through a load test and inspection.
- The 'raise' and 'lower' limit switches shall work correctly to help prevent two-blocking and accidental floor contact.

3. PERSONS AUTHORIZED TO OPERATE REMOTE CONTROLLED CRANES.

- Only properly trained employees who have been designated by management shall be permitted to operate the crane.
- Both the operator and management shall insure the correct controller to operate the crane is selected and that any spare equipment capable of controlling the crane is completely isolated and held under lock and key.
- The crane shall not be operated by personnel who cannot read and understand the signs, notices and operating instructions.
- The crane shall not be operated by personnel with seriously defective eyesight or hearing, personnel under the influence of drugs or alcohol that will impair judgment, or personnel who may be suffering from a disease which may cause physical failure.

4. TRAINING CHECKLIST FOR OPERATORS OF REMOTE CONTROLLED CRANES.
As a minimum, Portable Remote Control Operators shall:

- have knowledge of hazards inherent to crane operation.
- have knowledge of safety guidelines for portable remote controlled cranes.
- have the ability to judge distance to stationary objects.
- have knowledge of the portable remote control system controller's operation.
- have performed limit switch test procedure before operating the crane.
- have performed hoist, trolley and bridge brake test procedure before operating the crane.
- have instructions as to plugging of crane motions when and where authorized.
- observe signal lights on crane.
- avoid striking any obstructions.
- check for proper clearance of lifts or hooks before moving bridge or trolley.
- properly store the portable remote controller when not in use.
- know how to properly transfer the portable remote controller to another person.
- report unsafe or unusual operating conditions.
- use caution in approaching bridge or trolley end-stops.
- know the crane's capacity.
- keep body clear of lifts, avoiding 'pinch' points.
- Inspect cables and hooks.



5. THE OPERATING AREA FOR THE REMOTE CONTROLLED CRANE.

- Unobstructed aisles between equipment, stock, etc. shall be maintained for the PRC crane operator's movement. These aisles should be a minimum of 3 feet wide (1m) or per local regulations.
- PRC crane operators shall always position themselves in a safe location with the best view of the crane they are controlling and never operate the crane blindly. They shall always keep the crane and load in sight, staying as close as practical to the crane load while maintaining a safe harms-way distance. Operators shall never position themselves or others underneath the load or in a 'pinch' point.

6. THE HAND-HELD PORTABLE REMOTE CONTROLLER.

- Typically, the portable remote controller incorporates a Push-To-Operate (PTO) bar or START button, and its motion switches are spring return to OFF. The PTO bar acts as a guard for these switches to prevent movement of the crane if one of the switches is accidentally bumped. These switches and the PTO bar must never be mechanically blocked in any 'ON' position.
- Using the power ON/OFF switch(es), the portable remote controller shall be switched 'OFF' when not in use. When the controller is equipped with a STOP button, it shall be set to the 'STOP' position before switching off power to the controller. In addition, if equipped with a key, the key should be removed after use and kept in a secure location.
- A prescribed, controlled, storage space shall be provided for portable remote controllers. All controllers shall have their batteries removed and be placed there when not in use. This precaution is intended to prevent unauthorized personnel from operating the remote controlled crane.
- When an operator is putting on or taking off the controller by means of its belt loop strap, carrying harness, or shoulder strap, the controller shall be switched OFF beforehand, using the appropriate ON/OFF switch(es). When the controller is equipped with a STOP button, it shall be set to the 'STOP' position before switching off power to the controller.
- The portable remote controller shall always be switched 'OFF' when not in use and, when practical, stored under lock and key.



7. OPERATING THE REMOTE CONTROLLED CRANE.

- All crane limit switches shall be checked at the beginning of each turn or when a new operator takes control of the crane. While checking the limit switches, the hoist shall be centered over an area free of personnel and equipment so that if the limit switches fail, and the hook and block assembly falls, no one will be injured and no equipment will be damaged.
- The limit switches shall never be used as a regular stopping devices. They are intended to be protective devices only.
- The bridge and trolley brakes shall be tested at the beginning of each turn or when a new operator takes control of the crane. They should be tested with the bridge and trolley at low speed.
- When lifting maximum or near maximum loads, the operator shall test the hoist brakes by raising the load a few inches from the floor. If hoist brakes do not hold, the load shall be immediately lowered to the floor and a report made to the supervisor.
- Do not make lifts in excess of the rated capacity of the crane.
- When making lifts, the bridge and trolley shall be centered directly over the load to prevent load swinging when the load is raised.
- Side pulls shall be made only with the permission of, and under direct supervision of management. When such a lift is being made, operators shall not position themselves in the line or path of travel of the load, but shall operate the crane from a position to the side opposite to the path of travel.
- When raising or lowering a load, proceed slowly and make certain the load is under control. Tag lines shall be used for handling lengths or bulky loads. Take the slack out of the chains or slings gradually. Make sure all personnel are clear before making a lift.
- PRC crane operators shall keep all parts of their bodies away from the load and never position themselves under the load.
- Do not make a lift or move the crane if anyone is in a position to be injured.
- If a PRC crane operator is being helped, he or she shall not move the crane until he or she receives an 'all clear' signal from the helper(s).
- Loads shall not be carried over workers' heads.
- If anyone is in the path of travel, the portable remote control crane operator shall stop and clear the area before proceeding.
- Bumping into runway stops or into other cranes on the same runway is prohibited.
- When moving the crane, the PRC crane operator shall make sure the hook block, attachment and/or cables will not fall on nearby equipment.
- The PRC crane operator shall not drag slings, chains, etc. along the floor. These could snag on something on the floor, causing the cables to break and strike the operator or a fellow worker.
- If gloves are not required for safety reasons, they shall not be used when operating the portable remote controller.



7. OPERATING THE REMOTE CONTROLLED CRANE, continued.

- All loose material or parts shall be removed from the load before starting the lift. Such material can fall and injure people below.
- The PRC crane operator shall hoist lifts high enough to clear all apparatus and workers below the crane.
- Plugging shall not be used as a regular means of stopping the crane and should be used for emergency stops only. If approved, plugging should only be performed as dictated by plant operating procedures.
- If PRC crane operators are asked to do something they believe unsafe, they shall call their supervisors for advice.
- PRC crane operators shall never permit anyone to ride on the load or hook except when authorized by their supervisor.
- When another crane on the same runway is stationary with or without a load, the PRC crane operator shall maintain a safe distance between the crane being operated and the stationary crane. In a power outage, the PRC crane operator shall set the ON/OFF switch(es) on the controller to 'OFF', keeping them in the OFF position until power is restored.
- If the PRC crane fails to respond correctly, the operator shall stop operation immediately by setting the ON/OFF switch(es) on the controller to 'OFF'. When the controller is equipped with a STOP button, this shall be set to the 'STOP' position before switching off power to the controller. The fault condition shall be reported immediately to a supervisor.
- Outside cranes subject to movement by winds, storms, etc. shall be securely anchored when left unattended. If the crane is equipped with a bridge parking brake, it shall also be set.

8. BOARDING THE REMOTE CONTROLLED CRANE (MAINTENANCE CREW).

- The PRC crane shall not be boarded without permission of the supervisor in charge of crane operations in the area.
- Using the power ON/OFF switch(es), the person boarding the PRC crane shall switch the portable remote controller to 'OFF' and take it with him or her on to the crane. When the controller is equipped with a STOP button, this shall be set to the 'STOP' position before switching off power to the controller.
- If the boarding party consists of more than one person, one person shall be designated as the leader of the boarding party.
- The leader shall board the crane first, open and lock out the main switch (securing it with a padlock), and then signal the other members of the party that it is safe for them to board the crane.

9. ON BOARD THE REMOTE CONTROLLED CRANE (MAINTENANCE CREW).

- Head room is at a minimum in some crane cabs and on some crane walkways. Caution shall be exercised by all people on board such cranes. Hard hats shall be worn at all times.
- If the repair crew consists of more than one person, one person shall be designated as the crew leader.



9. ON BOARD THE REMOTE CONTROLLED CRANE, continued.

- Warning signs shall be placed on the floor beneath the crane or suspended from the crane indicating the crane is being serviced.
- If any work to be done on the crane is carried out in locations unprotected by standard handrails, safety belts shall be worn by all crew members working in such unprotected locations.
- All tools and equipment shall be moved onto the crane by the use of hand lines. All tools and equipment shall be securely attached to hand lines.
- If it is necessary to have the control circuits on the crane energized, the repair crew leader shall open all power circuits to the motions before closing the main switch.
- If, during the course of repairs, it becomes necessary to move the crane, it shall be the responsibility of the crew leader to insure that all personnel located on, and within the operational area of the crane are in a safe position out of harms-way. In addition the crew leader shall insure all tools and materials are stowed or tightly restrained before the crane is moved.
- When the repair work is completed, the crew leader shall see that all crew members are off of the crane before he or she closes the main switch.
- If more than one person is on board the PRC crane, one person shall be made responsible for seeing that all workers are off the crane before the portable remote controller is returned to operational use.

10. REMOTE CONTROLLED CRANE UNDER REPAIR.

- All persons operating other cranes on the same or adjacent runways shall be notified before anyone boards the subject crane. Such notification should include limitations of adjacent crane movement while others are on board.
- PRC cranes which have been pre-positioned for repairs and cannot be moved should be protected against being bumped by other cranes on the runway. Suitable bumpers adequate for the job should be installed on the exposed sides of the crane under repair and as far away from the crane as possible, with a minimum distance of 20 ft. (approximately 6.1 m). The location of these bumpers shall be indicated by red lights so that they are clearly visible to other persons operating cranes traveling on the same runway. When it is impossible to use bumpers for protection, red lights shall be placed in clear view of other persons operating cranes on the same runway to indicate the restricted travel zone. It is desirable that such red lights be located a minimum of 20 ft. (approx. 6.1 m) from the crane under repair.
- All operators of cranes on the same runway must be informed of the repair work, thoroughly instructed as to what their conduct should be for the duration of said repairs, and informed when repairs are completed.



10. REMOTE CONTROLLED CRANE UNDER REPAIR, continued.

- When there is a runway adjacent to the runway on which the crane is being repaired, and if any hazard exists involving repairmen, red lights shall be placed in clear view of persons traveling on the adjacent runway to indicate the restricted travel zone. It is desirable that such red lights be located a minimum of 20 ft. (approx. 6.1 m) from the crane under repair. When it is necessary to operate cranes on adjacent runways, such cranes shall come to a full stop before entering the restricted area. Cranes traveling on adjacent runways may only proceed through the restricted area when permission has been received from a signalman posted for this purpose.
- Access of persons to and from the crane being repaired shall be under the control of the repair crew leader.
- The floor area below the point where crane repairs are being made shall be roped off and posted with danger signs.
- Handling of all small tools and materials, etc. from ground level to workers above shall be accomplished through the use of hand lines. Tools, materials, etc. shall not be tossed from the crane to the ground level and vice versa.
- If crane repairs make it necessary for crew members to work on areas of the crane other than those protected by standard handrails, such crew members shall wear approved safety belts.
- If it is necessary to move the crane to check the performance of operation, the crew leader shall designate who remains on the crane. The crew leader shall insure that all personnel located on, and within the operational area of the crane are physically located in a safe position out of harms-way. In addition the crew leader shall insure all tools and materials are stowed or tightly restrained before the main switch is closed and the crane is put into operation.
- Upon completion of repairs, it is the crew leader's duty to personally insure that each person has left the crane and is clear before he or she removes the lock above the main switch and the crane is put back in operation.

11. THE CONDITION OF THE REMOTE CONTROLLED CRANE. It is recommended that a written report be sent to your supervisor whenever you detect any condition that makes the crane unsafe. Many plants supply printed forms for this purpose. The PRC crane operator shall fill out these forms and turn them in at the end of each shift. Certain faults which the PRC crane operator may detect will be so critical that the crane must be shut down at once and not operated until the fault is corrected. Typical check list items may include some or all of the following:

- Condition of hoisting cable, drum, and hook blocks (broken strands, clipped sheave wheels, etc.).
- Condition of brakes (hoist, trolley and bridge).
- Oil or brake fluid leaks on the runway area.
- Alignment of bridge (screeching or squealing wheels indicate that bridge is out of line).
- Condition of bridge structure (broken welds, cracks and distortion).
- Broken, cracked or chipped rails on bridge or runway.



11. THE CONDITION OF THE REMOTE CONTROLLED CRANE, continued.

- Condition and security of trolley and bridge rail end-stops (missing or damaged from impact).
- Condition of all limit switches.
- Conditions of controls (electrical or mechanical defects that may lead to faulty operation).
- Condition of electric motors (carbon dust around inspection covers indicate worn brushes).
- Condition of gears (grinding or squealing may mean a lack of lubrication or foreign materials in gear teeth).
- Frequent overload relay tripping of power circuits.
- Mechanical parts loosened by vibration (loose rivets, covers, etc.).
- Wheel condition (flange wear, cracks, holes, or visible signs of bearing damage).
- Bumpy riding (worn wheels).
- Worn collector shoes or bars.
- Burned out, broken, or inoperable warning or signal lights.
- Unintended stopping or starting of any crane motion, warning device, light or auxiliary function.
- Condition of walkways and ladders (missing or loose handrails, ladder rungs, etc.)

Portable Remote-controlled Crane operators shall not attempt to make any repairs by themselves. The fault condition(s) shall be reported to a supervisor to enable repairs to be carried out by suitably qualified personnel.

END

Internet Address for All CATTRON-THEIMEG™ Companies: www.cattron-theimeg.com



This page intentionally left blank.



RECOMMENDED SAFETY RULES FOR PORTABLE RADIO REMOTE CONTROLLED (PRRC) LOCOMOTIVES

The information contained herein is based on data gathered from various users of portable radio remote control locomotive systems. **We emphasize that the recommendations contained herein are not intended to supersede the rules or regulations of our customers, or the rules and regulations of any applicable local, state, or federal government organizations. It must be fully understood that the recommendations contained herein are provided solely for your consideration and possible adoption.**

TABLE OF CONTENTS

SECTION	TITLE	PAGE
1	Preface	1
2	Operator Safety Basics	2
2-1	Area Inspection	2
2-2	Locomotive & Railcar Inspection (mechanical & structural)	2
2-3	Operational Safety Check	2
3	Persons Authorized to Operate Remote Controlled Locomotives	2
4	Training Checklist for Operation of Remote Controlled Locomotives	3
5	Operating Area for Remote Controlled Locomotives	3
6	Pre-departure Checks under Manual Control	3
7	The Portable Radio Remote Controller	4
8	Transferring the Locomotive to Radio Remote Control	5
9	Pre-departure Checks under Radio Remote Control	5
10	Operating the Remote Controlled Locomotive	6
11	Boarding the Remote Controlled Locomotive	7
12	On Board the Remote Controlled Locomotive	8
13	Remote Controlled Locomotive under Repair	8
14	The Condition of the Remote Controlled Locomotive	10

1. PREFACE.

- 1-1. Locomotives operate in two motions. They are large, bulky pieces of equipment that handle heavy loads efficiently at comparatively high speeds. Quite frequently they are operated in restricted areas where workmen are engaged in various tasks or there is pedestrian or vehicular traffic. Under these conditions locomotive operators using Portable Radio Remote Control must take great care, and workmen must be constantly on the alert if accidents are to be avoided.
- 1-2. The following guidelines have been carefully assembled and are promoted to indicate just how important your careful and thoughtful actions are in helping to protect you and your fellow workers from harm, and also to prevent equipment damage.
- 1-3. These guidelines cover Locomotives when they are operational in Portable Radio Remote Control (PRRC) mode. If a locomotive is operated from cab control, the PRRC system's controller(s) should be completely isolated by removing the battery and stored under lock and key.
- 1-4. A routine pre-shift inspection of the locomotive takes a lot less time than repairing a locomotive suffering from a major problem. In addition, such pre-shift inspections are to be considered as 'safety basics' which are an important part of a locomotive operator's duties.



2. **OPERATOR SAFETY BASICS.** Before starting your shift as the locomotive operator, you should make sure the locomotive has a current inspection certificate and that qualified personnel have carried out the following inspections and checks. If any item below does not pass inspection, you should notify your supervisor immediately. In many cases, the problem will need to be fixed before you are allowed to operate the locomotive. In addition, did you realize that the person now reading these instructions is primarily responsible for his or her own health and safety?

2-1 **Area Inspection.**

- Take a good look around the work area for any obstructions.
- Check that the rails are intact and not bent or damaged.
- Make sure there are no fresh oil or fluid leaks on the track bed below where the locomotive is standing.
- When installed, insure rail stops are physically secure and free of damage at the end of the rail track.

2-2. **Locomotive and Rail Car Inspection** (mechanical & structural).

- Check for proper fluid levels and make sure all grease fittings are lubricated to manufacturer recommendations.
- Check the locomotive and rail car wheels for flange wear, cracks, holes, or visible signs of bearing damage.
- Check all locomotive and rail car hoses and couplings for wear and physical damage.

2-3. **Operational Safety Check.** As a locomotive operator, you should satisfy yourself of the following. If any item below does not meet the checklist criteria, you shall immediately notify your supervisor. In many cases, the problem will need to be fixed before you are allowed to operate the locomotive. Remember that the person now reading these instructions is primarily responsible for his or her own health and safety!

- Horn, headlight, bell, and all other warning devices shall be in working order.
- All locomotive manual (cab) controls shall be in good working order.
- STOP Buttons (when equipped) shall be in working order.
- The locomotive and railcar braking systems (including the application of sand when equipped) are fully operational. The only way to ensure this is by testing under 'MANUAL' (cab) control.

3. **PERSONS AUTHORIZED TO OPERATE REMOTE CONTROL LOCOMOTIVES.**

- Only properly trained employees who have been designated by management shall be permitted to operate the locomotive(s).
- The locomotive shall not be operated by personnel who cannot read and understand the signs, notices and operating instructions.
- The locomotive shall not be operated by a person with seriously defective eyesight or hearing, personnel under the influence of drugs or alcohol that will impair judgment, or personnel who may be suffering from a disease which may cause physical failure.



4. TRAINING CHECKLIST FOR OPERATORS OF REMOTE CONTROLLED LOCOMOTIVES. As a minimum, Locomotive Operators shall:

- have knowledge of hazards inherent to locomotive operation
- have knowledge of safety rules for remote controlled locomotives
- have the ability to judge distance to stationary objects
- have knowledge of the PRRC system controller's operation – see customized operational description provided with the controller
- inspect all aspects of the locomotive in manual operation before commencing remote control operation
- have performed pre-departure brake test procedures in manual operation before commencing remote control operation
- know how to transfer the locomotive from 'MANUAL' to 'REMOTE' Control
- be familiar with the procedure for testing all operational features
- observe all signal lights and other railroad signaling devices
- avoid striking any obstructions
- check for proper clearance before entering buildings, etc.
- properly store the portable radio remote controller when not in use
- know how to properly transfer the portable radio remote controller to another person
- report unsafe or unusual operating conditions
- use caution in approaching all crossings
- keep body clear of the rail track and avoid 'pinch' points

5. THE OPERATING AREA FOR THE REMOTE CONTROLLED LOCOMOTIVE.

- PRRC operators shall always position themselves in a safe location with the best view of the train they are controlling and never operate the locomotive blindly.
- Operators shall always keep the train and locomotive in sight, staying as close as practical to the locomotive while maintaining a safe harms-way distance.
- Operators shall follow their Employer's Safety Rules, Procedures, and Directives in regard to riding on, walking in front of, and boarding/de-boarding at the leading edge of the train in respect to its direction of travel.
- Operators shall never position themselves or others in a 'pinch' point between rail cars, other locomotives, or track side structures.
- Operators shall never position themselves between the rails of tracks.

6. PRE-DEPARTURE CHECKS UNDER MANUAL CONTROL.

- When installed, insure the STOP buttons located on the sides of the locomotive are pulled 'OUT' immediately before boarding the locomotive.
- When installed to the locomotive, insure: (1) Remote Control Disconnect Switch is set to 'OFF', (2) MANUAL/REMOTE Transfer Switch is set to 'MANUAL', and (3) MANUAL/REMOTE Air Valves are in the 'MANUAL' (down) position.



6. PRE-DEPARTURE CHECKS UNDER MANUAL CONTROL, continued.

- Perform all locomotive pre-departure tests according to the locomotive manufacturer's operation manual. Do not proceed unless the locomotive is operating satisfactorily according to the manufacturer's instructions.
- All non-motion control functions (Horn, headlight, bell, sanders, uncouple, etc.) shall be checked at the beginning of each turn or when a new operator takes control of the locomotive.
- All braking functions shall be checked independently to insure the locomotive is responding correctly to all brake applications and release commands. Observe gages in the cab for proper readings and verify the brake mechanisms/cylinders operate properly.
- Test train brakes (if equipped).

7. THE PORTABLE RADIO REMOTE CONTROLLER.

- Typically, the portable radio remote controller incorporates a Push-To-Operate (PTO) bar and its THROTTLE switch will spring return to IDLE. The PTO bar acts as a guard for the throttle switch to prevent movement of the locomotive if the switch is accidentally bumped. The THROTTLE switch and the PTO bar must never be mechanically blocked in any 'ON' position.
- When the portable radio remote controller incorporates a 'Vigilance' system in place of the Push-To-Operate (PTO) bar, the designated VIGILANCE pushbutton, bar switch, or toggle switch may need to be momentarily depressed to initiate a motion control function. The designated VIGILANCE pushbutton, bar switch, or toggle switch must never be mechanically blocked in the 'ON' position.
- Direction and brake levers normally have no spring return and will stay where they are placed. Although the PTO Bar is not normally required for brake apply commands, it must be depressed to release the independent brakes and, when equipped, the train brakes.
- Using the power ON/OFF switch(es), the portable radio remote controller shall be switched 'OFF' when not in use. When the controller is equipped with a STOP button, it shall be set to the 'STOP' position before switching off power to the controller. In addition, if equipped with a key, the key should be removed after use and kept in a secure location.
- To prevent unauthorized personnel from operating the remote controlled locomotive, a prescribed, controlled, storage space shall be provided for portable radio remote controllers. All controllers shall have their batteries removed and be stored there when not in use.
- When an operator is putting on or taking off the controller by means of its belt loop strap, carrying harness, or shoulder strap, the controller shall be switched OFF beforehand, using the appropriate ON/OFF switch(es). When the controller is equipped with a STOP button, it shall be set to the 'STOP' position before switching off power to the controller.
- The portable radio remote controller shall always be switched 'OFF' when not in use and, when practical, stored under lock and key.



8. TRANSFERRING THE LOCOMOTIVE TO RADIO REMOTE CONTROL.

- Both the operator and management shall insure the correct controller to operate the locomotive is identified and selected.
- Both the operator and management shall insure that any spare equipment capable of locomotive control is completely isolated and stored under lock and key.
- Immediately before transferring the locomotive from 'MANUAL' to 'REMOTE' control, insure the locomotive cab controls are set as follows:
 - ⇒ Throttle to 'IDLE'
 - ⇒ Reverser to 'NEUTRAL' with handle removed
 - ⇒ Independent Brake Lever to 'RUN' position and handle removed
 - ⇒ Automatic Brake Lever to 'LAP' position and handle removed
 - ⇒ Double Heading Cock to trailing position (MU - operation)
 - ⇒ MANUAL/REMOTE Air Valves to 'REMOTE' (up) position
 - ⇒ Remote Control Disconnect Switch to 'ON' position
 - ⇒ MANUAL/REMOTE Transfer Switch to 'REMOTE' position

9. PRE-DEPARTURE CHECKS UNDER RADIO REMOTE CONTROL. Following is a typical pre-departure checkout procedure based upon a typical configuration. Refer to the information supplied with the equipment for the specific checkout procedure.

- With the remote controller set to 'OFF', check brake cylinder for air pressure. The red external locomotive lights (if equipped) should illuminate, indicating independent brakes are applied.
- Set remote controller to 'ON'. When applicable, check the PRRC system display(s) for any fault/alarm conditions and correct the same before operating the appropriate ALARM/SYSTEM RESET switch.
- With Push to Operate (PTO) Bar depressed, move the independent brake lever on remote controller to release (REL). Independent brakes should release and the red external locomotive lights should extinguish.
- Move independent brake lever on remote controller to an 'apply' position (SA = Slow Apply, QA = Quick Apply). Independent brakes should apply with corresponding external red lights illuminated.
- Move independent brake lever on remote controller to 'EMG' (emergency) position. When equipped, train brakes should apply along with independent brakes. When equipped, sand should also be applied.
- Move direction lever on remote controller to 'FORWARD'. Forward direction should be selected, as indicated by the clear external locomotive lights (if equipped) illuminating.
- Move direction lever on remote controller to 'REVERSE'. Reverse direction should be selected as indicated by the amber external locomotive lights (if equipped) illuminating and the clear lights extinguishing.



9. PRE-DEPARTURE CHECKS UNDER RADIO REMOTE CONTROL, continued.

- Move direction lever on remote controller to center 'NEUTRAL' position. 'NEUTRAL' should be selected as indicated by both amber and clear lights extinguished.
- With independent brakes released (PTO must be depressed and maintained) and a direction selected, advance THROTTLE lever on remote controller to first 'step'. The green external locomotive lights (if equipped) should illuminate and the locomotive should move.
- Release Push to Operate (PTO) Bar on remote controller. Throttle should return to 'idle' and independent brakes should apply, stopping the locomotive (red external locomotive lights illuminated and green lights extinguished).
- With independent brakes released (PTO must be depressed and maintained) and a direction selected, advance THROTTLE lever on remote controller to first 'step'. The green external locomotive lights should illuminate and the locomotive should move.
- Tilt remote controller 60° or more. Throttle should return to 'idle' and independent brakes should apply, stopping the locomotive (red external locomotive lights illuminated and green lights extinguished). Return the remote controller to the upright position and independent brakes should release (red external lights extinguished).
- With independent brakes released (PTO must be depressed and maintained) and a direction selected, advance THROTTLE lever on remote controller to first 'step'. The green external locomotive lights should illuminate and the locomotive should move.
- Set remote controller to 'OFF'. Throttle should return to 'idle' and independent brakes should apply, stopping the locomotive (red external locomotive lights illuminated and green lights extinguished).
- De-board the locomotive and assume an operating position on the ground next to the locomotive. Set remote controller to 'ON'. With independent brakes released (PTO must be depressed and maintained) and a direction selected, advance THROTTLE lever on remote controller to first 'step'. The green external locomotive lights should illuminate and the locomotive should move. Immediately after the locomotive starts to move, push in a STOP switch (if equipped) on side of locomotive. The locomotive should stop and independent brakes should apply. Repeat this step with all STOP switches. STOP switches should be checked daily. If the above checks have been successfully completed, the locomotive is now ready for remote control operation.

10. OPERATING THE REMOTE CONTROLLED LOCOMOTIVE.

- When ready to move the locomotive for the first time, proceed slowly and make certain the load is under control.
- Take the slack out of the couplers gradually and make sure hands and other objects are clear before making command.
- Keep all parts of the body away from the rolling stock.
- Do not walk on the tracks between the rails.
- Do not move the locomotive or train if anyone is in a position to be injured.
- If anyone is in the path of travel, stop and sound the horn before proceeding.



10. OPERATING THE REMOTE CONTROLLED LOCOMOTIVE, continued.

- If gloves are not required for safety reasons, they shall not be used when operating the portable remote controller.
- PRRC operators shall not use a STOP switch, VIGILANCE switch or Push-to-Operate bar as a utility stopping device.
- If PRRC locomotive operators are asked to do something they believe unsafe, they shall contact their supervisor for advice.
- PRRC locomotive operators shall never permit anyone to ride in the locomotive cab except when authorized by their supervisor.
- Heavy bumping of cars or rail stops is prohibited.
- When leaving the locomotive for any reason, set the locomotive throttle to 'IDLE', apply the brakes, and set the ON/OFF switch(es) on the controller to 'OFF'. When the controller is equipped with a STOP button, this shall be set to the 'STOP' position before switching off power to the controller.
- If the locomotive fails to respond correctly under remote control, the operator shall stop operation immediately by setting the ON/OFF switch(es) on the controller to 'OFF'. When the controller is equipped with a STOP button, this shall be set to the 'STOP' position before switching off power to the controller. The fault condition shall be reported immediately to a supervisor.
- Do not allow any unauthorized person to operate or assist with the operation while in Radio Remote Control.
- Do not operate the Remote Controller from a distance where the locomotive, railcars, rail-track, and all surrounding objects are not visible.
- Under no circumstances should an operator override any of the safety features built into the PRRC system or the locomotive.

11. BOARDING THE REMOTE CONTROLLED LOCOMOTIVE (MAINTENANCE CREW).

- The PRRC locomotive shall not be boarded without permission of the supervisor in charge of railroad operations in the area.
- Using the power ON/OFF switch(es), the person boarding the PRRC locomotive shall switch the portable radio remote controller to 'OFF' and take it with him or her on to the locomotive. When the controller is equipped with a STOP button, this shall be set to the 'STOP' position before switching off power to the controller.
- If the boarding party consists of more than one person, one person shall be designated as the leader of the boarding party.
- The leader shall board the locomotive first, secure the throttle and brakes, and then signal the other members of the party that it is safe for them to board.



12. ON BOARD THE REMOTE CONTROLLED LOCOMOTIVE (MAINTENANCE CREW).

- Headroom is at a minimum in some locomotive cabs and on some engine walkways. Caution shall be exercised by all people on board such locomotives. Hard hats shall be worn at all times.
- If the maintenance crew consists of more than one person, one person shall be designated as the crew leader.
- The leader shall mark all locomotives that have been pre-positioned for maintenance with a blue flag. The locomotive shall not be coupled to, or moved in any manner, while the blue flag is in position. The leader is solely responsible for removing the blue flag before moving the locomotive, or when maintenance has been completed.
- Warning signs shall be placed on the front, rear, and both sides of the locomotive to indicate that maintenance is being carried out.
- If it is necessary to have the control circuits on the locomotive energized, the leader shall insure that traction power is disabled (i.e. generator field switch set to the 'OFF' position).
- If, during the course of maintenance, it becomes necessary to move the locomotive, it shall be the responsibility of the crew leader to insure that all personnel located on, and inside the locomotive are in a safe position out of harms-way. In addition the crew leader shall insure all tools and materials are stowed or tightly restrained, all doors are secured, and the blue flag is removed before moving the locomotive.
- When the maintenance work is completed, the leader shall see that all personnel are off the locomotive before he or she re-enables traction power.
- If more than one person is on board the locomotive, one person shall be made responsible for seeing that all personnel are off the locomotive before the portable radio remote controller is returned to operational use.

13. REMOTE CONTROLLED LOCOMOTIVE UNDER REPAIR.

- All persons operating other locomotives on the same or adjacent tracks shall be notified before anyone boards the subject locomotive. Such notification should include limitations of adjacent locomotive movement while others are on board.
- If it is necessary to have the control circuits on the locomotive energized, the leader shall insure that traction power is disabled (i.e. generator field switch set to the 'OFF' position).
- The leader shall mark all locomotives that have been pre-positioned for repairs, and cannot be moved during repairs, with a blue flag. The locomotive shall not be coupled to, or moved in any manner, while the blue flag is in position. The leader is solely responsible for removing the blue flag when repairs have been completed.
- Locomotives that have been pre-positioned for repairs, and cannot be moved during repairs, shall be protected against being bumped by other locomotives on the track. Suitable derailleurs adequate for the job should be installed on both ends of the locomotive under repair and as far away from the locomotive as possible with a minimum distance of 100 feet. The location of these derailleurs shall be indicated by red lights placed so that they are clearly visible to other persons operating locomotives traveling on the same or adjacent tracks.



13. REMOTE CONTROLLED LOCOMOTIVE UNDER REPAIR, continued.

- When it is impossible to use derailleurs for protection, red lights shall be placed in clear view of other persons operating locomotives on the same or adjacent tracks to indicate the restricted travel zone. It is desirable that such red lights be located a minimum of 100 feet (approx. 30.5 m) from the locomotive under repair.
- All operators of locomotives on the same or adjacent tracks must be informed of the repair work, thoroughly instructed as to what their conduct should be for the duration of said repairs, and informed when repairs are completed.
- When there is a track adjacent to that of the locomotive being repaired, and if any hazard exists involving repairmen, red lights shall be placed in clear view of persons traveling on the adjacent tracks to indicate the restricted travel zone. It is desirable that such red lights be located a minimum of 100 ft. (approx. 30.5 m) from the locomotive under repair.
- When it is necessary to continue operation of locomotives on adjacent tracks, such locomotives shall come to a full stop before entering the restricted area. Locomotives on adjacent tracks may only proceed through the restricted area when permission has been received from a signalman posted for this purpose.
- Access of persons to and from the locomotive being repaired should be under the control of the repair crew leader.
- Warning signs shall be placed on the front, rear, and both sides of the locomotive to indicate that repairs are being carried out.
- Handling of all small tools and materials, etc. from ground level to workers above shall be accomplished safely. Tools, materials, etc. shall not be tossed from the locomotive to the ground level and vice versa.
- If it is necessary to move the locomotive to check the performance of operation, the crew leader shall designate who remains on the locomotive. The crew leader shall insure that all personnel located on, and inside the locomotive are physically located in a safe position out of harms-way. In addition the crew leader shall insure all tools and materials are stowed or tightly restrained and that all doors are secured before the locomotive is moved.
- When the maintenance work is completed, the leader shall see that all personnel are off the locomotive before he or she re-enables traction power.



14. THE CONDITION OF THE REMOTE CONTROLLED LOCOMOTIVE. It is recommended that a written report be sent to your supervisor whenever you detect any condition that makes the locomotive unsafe. Many plants supply printed forms for this purpose. The radio control locomotive operator should fill out these forms and turn them in at the end of each shift. Certain faults which the radio control locomotive operator may detect will be so critical that the locomotive must be shut down at once and not operated until the fault is corrected. Typical check list items may include some or all of the following:

- Condition of engine, brakes, and auxiliary functions (i.e., headlight, horn).
- Fresh oil or fluid leaks on the track bed below where the locomotive is standing.
- Broken, cracked or chipped rails.
- Condition of controls (electrical or mechanical defects that may lead to faulty operation).
- Frequent overload relay tripping of power circuits.
- Mechanical parts loosened by vibration (loose rivets, covers, etc.).
- Wheel condition (flange wear, cracks, holes, or visible signs of bearing damage).
- Insufficient main reservoir air pressure or a bad compressor.
- Condition of hoses and couplings.
- Burned out, broken, or inoperable warning or signal lights.
- Unintended stopping or starting of any locomotive motion, warning device, light or auxiliary function.

Portable Remote-controlled Locomotive operators shall not attempt to make any repairs by themselves. The fault condition(s) shall be reported to a supervisor to enable repairs to be carried out by suitably qualified personnel.

END

Internet Address for All CATTRON-THEIMEG™ Companies: www.cattron-theimeg.com

CATTRON[®]

GROUP INTERNATIONAL

United States

Cattron-Theimeg Inc.
58 West Shenango Street
Sharpsville, PA 16150-1198
Phone: 1-724-962-3571
Fax: 1-724-962-4310
e-mail: mail@cattron-theimeg.com

Canada

Cattron-Theimeg Canada Ltd.
150 Armstrong Avenue, Units 5 & 6
Georgetown, Ontario L7G 5G8
Phone: 1-905-873-9440
Fax: 1-905-873-9449
e-mail: salescdn@cattron-theimeg.com

United Kingdom

Cattron-Theimeg (UK) Ltd.
Riverdene Industrial Estate,
Molesey Road, Hersham
Walton-on-Thames, Surrey KT12 4RY
Phone: 44-1932-247511
Fax: 44-1932-220937
e-mail: sales@cattronuk.com

South Africa

Cattron-Theimeg Africa (PTY.) Ltd.
24 O'Rielly Merry Road, Rynfield, Benoni
P.O. Box 15444, Farrarmere, Benoni
Gauteng 1518, South Africa
Phone: 27-11-425-1123
Fax: 27-11-849-5717
e-mail: cattron@iafrica.com

South America (Brazil)

Cattron-Theimeg Américas Ltda.
Rua Antonio Rodrigues de Carvalho, 435
13033-220 - Campinas – SP
Phone: 55-19-3243-7803
Fax: 55-19-3243-9258
e-mail: cattronamericas@cattron-theimeg.com

Europe (Germany)

Cattron-Theimeg Europe GmbH & Co.
Krefelder Straße 423-425
41066 Mönchengladbach
Phone: 49-2161-63630
Fax: 49-2161-6363100
e-mail: theimeg@theimeg.de

Internet Address for All CATTRON[®] Group International Companies: www.cattron-theimeg.com