



## Product Development

*CATTRON Engineering Group*

*LRM and PA Radio Module*  
**Manual**

**Document p/n: 9S02-7954-A001 Rev.A**

### CONFIDENTIALITY NOTICE

This correspondence and all information contained within are the exclusive, confidential and proprietary property of Cattron-Theimeg Inc. it is not to be reproduced, nor is it or any portion of it to be used by or disclosed to any other individual or legal entity, without the prior, written approval of Cattron-Theimeg Inc. Furthermore, the information contained within this correspondence is also to be handled in accordance with any and all confidentiality agreements between Cattron-Theimeg Inc. and the receiver or user of this information.

© Cattron-Theimeg Inc.

## Revision History

Date	Revision	Description	Signature / Date	
2010-10-06	EM1	Initial draft	Prepared	Pierre Montreuil
			Verified	
			Approved	
2010-10-06	EM2	General revision. Removed LQI measurement Updated the configuration section (section 5)	Prepared	Pierre Montreuil
			Verified	
			Approved	
2012-01-30	A	Fig 4.8 and 4.9 - Remove remaining references to LQI from drawings. Table 4.2 – Rename ESC_END for ESC_SOF [LaB] Added demodulated analog output on pin 48 and GND on pin 50	Prepared	Pierre Montreuil
			Verified	
			Approved	
			Prepared	
			Verified	
			Approved	

# Table of Contents

<b>1. INTRODUCTION .....</b>	<b>1-1</b>
1.1 PURPOSE.....	1-1
1.2 SCOPE.....	1-1
1.3 APPLICABILITY .....	1-1
1.4 DEFINITIONS, ACRONYMS.....	1-1
1.4.1 Definitions .....	1-1
1.4.2 Acronyms.....	1-1
<b>2. FEATURES SUMMARY.....</b>	<b>2-1</b>
<b>3. HOST INTERFACE DEFINITION.....</b>	<b>3-2</b>
3.1 PINS ASSIGNMENT .....	3-2
3.2 SIGNALS DESCRIPTION.....	3-3
<b>4. LRM CONFIGURATION CONCEPT.....</b>	<b>4-4</b>
4.1 I2C .....	4-4
4.2 SPI .....	4-4
4.3 CONSOLE INTERFACE.....	4-4
4.3.1 “Write” command .....	4-4
4.3.2 “Read” command .....	4-5
4.3.3 “Help” command .....	<b>Error! Bookmark not defined.</b>
4.4 STAND-ALONE TEST MODE.....	4-5
4.5 FIRMWARE DOWNLOAD.....	4-6
<b>5. REGISTERS MAP SUMMARY .....</b>	<b>5-7</b>
5.1 REGISTERS DESCRIPTION FIELDS .....	5-7
<b>6. REGISTERS .....</b>	<b>6-8</b>
6.1 SECTION 1 REGISTERS: HARDWARE INFORMATION BLOCK.....	6-8
6.1.1 HW Part Number .....	6-8
6.1.2 HW Revision .....	6-8
6.1.3 Serial Number .....	6-8
6.1.4 Default Operation mode.....	6-8
6.2 SECTION 2 REGISTERS: SOFTWARE INFORMATION BLOCK .....	6-8
6.2.1 SW Part Number.....	6-9
6.2.2 SW Revision .....	6-9
6.2.3 Register Map Version number .....	6-9
6.3 SECTION 5 REGISTERS: RF INTERFACE CONFIGURATION .....	6-9
6.4 SECTION 7 REGISTERS: TEST COMMANDS AND PARAMETERS.....	6-9
<b>7. TEST-SPECIFIC PARAMETERS .....</b>	<b>7-11</b>

79546+91071 TRX module meets Part 90 of the FCC rules and regulations. Compliance with the labeling requirements, FCC notices is required. In order to comply with FCC Certification requirements, the Original Equipment Manufacturer (OEM) must fulfill the following requirements.

1. The system integrator must place an exterior label on the outside of the final product housing the 79546+91071 TRX Module. The figure below shows the contents that must be included in this label.
2. 79546+91071 TRX modules may only be used with the antennas that have been tested and approved for use with the module.

### Labeling Requirements

The OEM must make sure that FCC labeling requirements are met. This includes a clearly visible exterior label on the outside of the final product housing that displays the contents shown in below.



**WARNING:** The 79546+91071 TRX modules have been tested by the FCC for use with other products without further certification (as per FCC Section 2.1091). Changes or modifications to this device not expressly approved by Cattron-Theimeg could void the user's authority to operate the equipment.

**NOTICE:** OEM's must verify the final end product complies with unintentional radiators (FCC Section 15.107 and 15.109) before providing a declaration of conformity for their final product to Part 15 of the FCC Rules.

**NOTICE:** The 79546+91071 TRX modules have been certified for mobile and fixed radio applications. If the module will be used for portable applications, the device must undergo SAR testing.

**RF Exposure WARNING:** This equipment complies with FCC radiation exposure limits set forth for an uncontrolled environment. This equipment should be installed and operated with minimum distance 20 cm between the radiator and your body. This transmitter must not be co-located or operating in conjunction with any other antenna or transmitter.

**NOTICE:** The preceding statement must be included as a CAUTION statement in OEM product manuals in order to alert users of FCC RF Exposure compliance.

79546+91071 TRX is designed for use in countless wireless applications requiring long range communications with low energy consumption. To ensure that the final product complies with the all of the regulatory requirements for the Modular Grant the following integration instructions should be followed. 79546+91071 TRX is limited to OEM installation ONLY. The OEM integrator is responsible for ensuring that the end-user has no manual instructions to remove or install the module.

**FCC Part 15.105(b) Warning Statement**

NOTE: This equipment has been tested and found to comply with the limits for a Class B digital device, pursuant to part 15 of the FCC Rules. These limits are designed to provide reasonable protection against harmful interference in a residential installation. This equipment generates, uses and can radiate radio frequency energy and, if not installed and used in accordance with the instructions, may cause harmful interference to radio communications. However, there is no guarantee that interference will not occur in a particular installation. If this equipment does cause harmful interference to radio or television reception, which can be determined by turning the equipment off and on, the user is encouraged to try to correct the interference by one or more of the following measures:

- Reorient or relocate the receiving antenna.
- Increase the separation between the equipment and receiver.
- Connect the equipment into an outlet on a circuit different from that to which the receiver is connected.
- Consult the dealer or an experienced radio/TV technician for help.

**IC RSS-GEN, Sec 7.1.2 Warning Statement- (Required for Transmitters)**

**ENGLISH:**

Under Industry Canada regulations, this radio transmitter may only operate using an antenna of a type and maximum (or lesser) gain approved for the transmitter by Industry Canada. To reduce potential radio interference to other users, the antenna type and its gain should be so chosen that the equivalent isotropically radiated power (e.i.r.p.) is not more than that necessary for successful communication.

**FRENCH:**

Conformément à la réglementation d'Industrie Canada, le présent émetteur radio peut fonctionner avec une antenne d'un type et d'un gain maximal (ou inférieur) approuvé pour l'émetteur par Industrie Canada. Dans le but de réduire les risques de brouillage radioélectrique à l'intention des autres utilisateurs, il faut choisir le type d'antenne et son gain de sorte que la puissance isotrope rayonnée équivalente (p.i.r.e.) ne dépasse pas l'intensité nécessaire à l'établissement d'une communication satisfaisante.

**IC RSS-GEN, Sec 7.1.2 Warning Statement-  
(Required for Transmitters w/ detachable antennas)**

**ENGLISH:**

This radio transmitter (IC: 1007A-79543, Model Number: 79543TRX) has been approved by Industry Canada to operate with the antenna types listed below with the maximum permissible gain and required antenna impedance for each antenna type indicated. Antenna types not included in this list, having a gain greater than the maximum gain indicated for that type, are strictly prohibited for use with this device.

**FRENCH:**

Le présent émetteur radio (IC:1007A-79543, Numéro de modèle: 79543TRX) a été approuvé par Industrie Canada pour fonctionner avec les types d'antennes énumérés ci-dessous ayant un gain admissible maximal et l'impédance requise pour chaque type d'antenne. Les types d'antennes non inclus dans cette liste, ou dont le gain est supérieur au gain maximal indiqué, sont strictement interdits pour l'exploitation de l'émetteur.

**IC RSS-102, Sec 2.6 Warning Statements**

**ENGLISH:**

The applicant is responsible for providing proper instructions to the user of the radio device, and any usage restrictions, including limits of exposure durations. The user manual shall

provide installation and operation instructions, as well as any special usage conditions, to ensure compliance with SAR and/or RF field strength limits. For instance, compliance distance shall be clearly stated in the user manual.

**FRENCH:**

Le requérant est responsable de fournir les instructions adéquates pour l'usage de l'équipement radio, ainsi que toutes les limitations, incluant les durées maximales d'exposition. Le manuel utilisateur doit fournir les instructions d'installation et d'opération, ainsi que toutes les conditions d'utilisation particulières, pour assurer la conformité avec les limites d'exposition aux champs électromagnétiques radiofréquences et/ou SAR.

Only the following authorized antennas may be used with the equipment:

Or the antenna gain less than 5.15dBi may be used with the equipment.

PRT-0000092 (whip antenna SPHS24221), 50Ohm, Gain: 0dBi

PRT-0000098 (whip antenna SPHS24221), 50Ohm, Gain: 0dBi

2PCA-8467-X001(Helical Antenna), 50Ohm, Gain: -8dBi

½ wave Omni antenna (ASPH7455), 5.15dBi

# 1. Introduction

## 1.1 Purpose

A new family of RF module is being developed by Cattron. This family includes high-selectivity radios covering several RF bands used world-wide for remote control applications. They are built around a common architecture, and present a uniform host interface definition. The host interface is used for data communication and radio configuration.

## 1.2 Scope

This document describes the host interface signal definitions, timings, operation mode, available functionalities, and provide details about its integration to Unity products. This document does not cover RF specifications or power supply specifications.

## 1.3 Applicability

Applies to LRM family members, P/N 2PCA-7954-xxxx, 2PCA-9107-xxxx

## 1.4 Definitions, Acronyms

### 1.4.1 Definitions

### 1.4.2 Acronyms

## 2. Features Summary

The LRM design addresses in first place Unity applications requirements. Its interface however is general enough to allow compatibility to other legacy Cattron products.

- Direct electrical compatibility to Unity RF interface – The interface is defined for natural integration to Unity product line.
- On-board CPU – The interface is controlled by an on-board Renesas CPU. This CPU controls also the details of operation of the RF peripherals. This approach has several advantages:
  - a. Unified host interface definition – A single host interface can be defined for all LRM family members.
  - b. Low requirement on Host CPU resources – The on-board CPU takes care of most aspects of RF control and timings. This allows releasing CPU resources (processing time, ROM/RAM space, hardware timers) that become available for more features addition.
  - c. Simple Host device drivers - Most of driver firmware complexity is transferred on the radio CPU; the Host device driver is much simpler, easier to test, and not as critical in regard to timings.
- Several interface modes – Several interface modes are supported in order to allow integration with other Cattron legacy products:
  - a. Data interface - support for synchronous and asynchronous serial link.
  - b. Configuration interface - support for I2C, SPI and asynchronous serial access.
- Stand-alone operation for firmware download and production test – The LRM can interface almost directly to a PC serial port for firmware download and for testing (no need for CPU board); only a TTL/RS232 translator is required (such as Cattron flashbox).
- Support for advanced feature – The LRM family is designed to support advanced features such as FHSS (Frequency Hopping Spread Spectrum) and Adaptive Channel Allocation, with minimal impact on Host firmware.

These different aspects are covered in the rest of this document.



## 3. Host Interface Definition

### 3.1 Pins Assignment

Description	IO	Signal	Pin Number		Signal	IO	Description
			49	50	GND		Ground
			47	48	RX_BB	O	RX Baseband signal
			45	46			
			43	44			
			41	42			
I2C clock / SPI clock	IO / O	I2C_SCL / SPI_SCK	39	40	SPI_PLE	I	SPI Strobe
SPI data input	I	SPI_PDI	37	38	I2C_SDA / SPI_PDO	IO / O	I2C Data / SPI data output
			35	36			
			33	34			
			31	32			
Data transfer Handshaking Signal	O	!READY	29	30			
3.3V DC supply	I	3V3	27	28			
Receive data	O	RXD	25	26	TXD	I	Transmit Data
RX Enable	I	!RX_EN	23	24	!TX_EN	I	Tx Enable
Serial port Configuration mode	I	!CONFIG	21	22	GND		Ground
			19	20	DCLK	O	Data Clock
			17	18			
			15	16			
			13	14			
			11	12			
			9	10			
Reset	I	!RESET	7	8			
CPU flash mode	I	!PGM	5	6			
Ground		GND-PA	3	4	GND-PA		Ground
Voltage Supply, RF power amplifier	I	VPA	1	2	VPA	I	Voltage Supply, RF power amplifier

Table 3.1 – Host Interface pins assignment

## 3.2 Signals Description

Pin Nb	Signal Name	I/O	Description	Category
1, 2	VPA	Input	Voltage Supply, RF power amplifier. This supply is needed when an optional piggy-back power amplifier board is used. Specifications (voltage, current) depend on piggy-back board used.	Power supply
3, 4	GND-PA		GND, RF power amplifier. This ground is connected internally to the module ground. It does not need to be connected when the module is used without PA	Power supply
22, 50	GND		System ground	Power supply
27	3V3	Input	3.3 V power supply voltage input (Vcc)	Power supply
5	!PGM	Input	Used to download on-board CPU firmware. Connect this signal to GND at power-up to force the CPU to enter firmware programming mode. Otherwise, connect to Vcc or leave unconnected	Module control
7	!RESET	Input	Main reset (active low). When reset is asserted, the content of the internal registers is lost.	Module control
29	!READY	Output	Handshaking signal for transmit or receive data on the host interface.	Data Transmission
23	!RX_EN	Input	Receive Enable (active low). Used to place the RF module in received mode *Note: when !TX_EN and !RX_EN are asserted simultaneously, the module is placed in STANDBY mode (low power consumption, internal registers conservation)	Data Transmission
24	!TX_EN	Input	Transmit Enable (active low). Used to activate telegram transmit process	Data Transmission
25	RXD	Output	Receive Data.	Data Transmission
26	TXD	Input	Transmit Data	Data Transmission
20	DCLK	Output	Data Clock. Active when serial port is configured in Synchronous Mode	Data Transmission
21	!CONFIG	Input	Used to configure the Data transmission signals RXD and TXD for module configuration. Asserting can be done in IDLE state only. Active low	Configuration interface
37	SPI_PDI	Input	If configuration interface configured for SPI: PDI (Peripheral Data In)	Configuration interface
38	I2C_SDA SPI_PDO	Bidi / Output	If configuration interface configured for: I2C: I2C SDA signal (data) SPI: PDO (Peripheral Data Out)	Configuration interface
39	I2C_SCL SPI_SCLK	Bidi / Input	If configuration interface configured for: I2C: I2C SCL signal (clock) SPI: SCLK (Serial Clock)	Configuration interface
40	SPI_PLE	Input	If configuration interface is configured for SPI PLE: (Peripheral Data Load Enable)	Configuration interface
48	RX_BB	Output	Analog demodulated RX signal	Data Transmission

**Table 3.2 - Host Interface signals description**

## 4. LRM Configuration Concept

All LRM configuration and status parameters are accessible through addressable registers.

- All parameters can be read in any of the following state: IDLE, RX, TX
- All writable parameters can be written in the following state: IDLE only

In order to facilitate adaptation to different platforms, the LRM configuration registers can be accessed using anyone of three methods: I2C, SPI or serial asynchronous with ASCII strings.

The definition of the configuration registers is given in reference [3]. This section addresses the basic description of all these three methods.

### 4.1 I2C

Signals I2C\_SDA and I2C\_SCL are used, according to the I2C standard protocol.

The LRM I2C configuration interface LRM emulates the behavior of the 1Kbytes I2C E2PROM found in all Unity RF modules. This way, I2C operation is consistent for all Unity radios.

- Device Address: 0xA0 (same as other Unity RF modules)
- Device select code:

b7	b6	b5	b4	b3	b2	b1	b0
1	0	1	0	0	A9	A8	$R/\overline{W}$

- Write operations: supports “Byte write” and “Page write”.
- Read operations: supports “Random Address Read” and “Sequential Random Read”.

For more details, refer to the M24C08 serial I2C E2PROM datasheet.

### 4.2 SPI

Signals SPI\_PDO, SPI\_PDI, SPI\_CLK and SPI\_PLE are used.

[TBD: Timings. (the LRM is a clock consumer)]

### 4.3 Console Interface

The serial interface configuration port is enabled by asserting !CONFIG signal; the serial interface is automatically reconfigured in asynchronous mode, running at 38400bps, 8N1. All ASCII strings received are interpreted as configuration commands. This mode is particularly useful for stand-alone testing, when the unit can be controlled from a PC or by an operator/tester using a terminal emulation program.

#### 4.3.1 “Write” command

**wrCmd register value** , where:

- wrCmd = write command. **w** or **wr** can be used and are equivalent
- register = register identification. Can use the register name or register address
- value = value to be written, in decimal or hexadecimal format. Hexadecimal values are preceded by ‘0x’

Examples:

wr txf 915000000 : Write 915000000 to register txf (Tx frequency)

wr 0x80 18 : Write 18 to register address 0x80  
wr txf 91500000 0x80 18: Concatenate the two writes above in a single instruction

### 4.3.2 “Read” command

**rdCmd reg** where:

rdCmd= read command. **r** or **rd** can be used and are equivalent

reg = register identification. Can use the register name or register address

Examples:

rd txf : Reads register txf (Tx frequency)

rd 0x80 : Reads register address 0x80

rd txf 0x80 : Reads registers txf and 0x80 in a single instruction

## 4.4 Stand-Alone Test Mode

The LRM can be operated in stand-alone mode for production/service tests. In this case, only a 3.3VDC supply is needed, and a RS232/TTL transceiver (like Cattron FLASHBOX) to connect to a PC serial port.

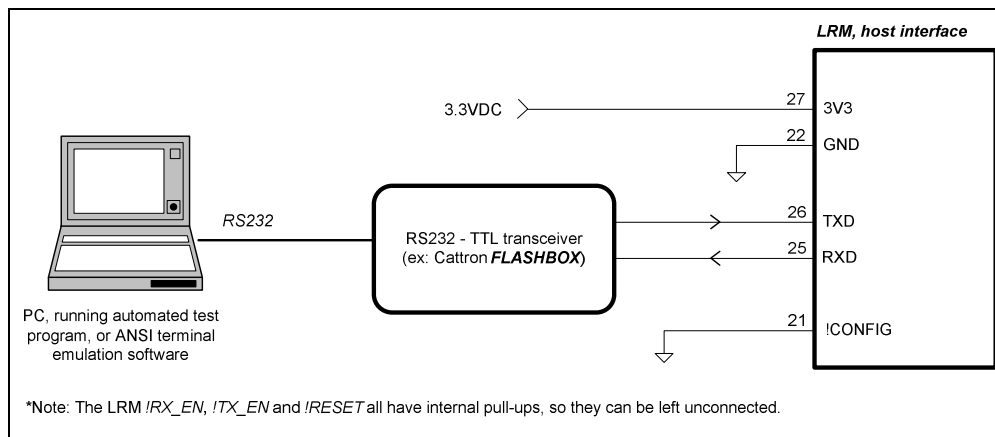

**Figure 4.1 - LRM connection for stand-alone operation**

The LRM will support several built-in test modes to ease testing from a PC. For example

#### a. Transmission Tests

- Generation of different type of carrier: unmodulated (CW), or modulated with “101010..” or pseudo-random sequence
- Automatic generation of test RF frames with predefined content

#### b. Reception Tests

- Measure PER (packet error rate) when receiving the predefined test RF frames
- Measure RF input level

More details about the test modes can be found in reference [3].

## 4.5 Firmware Download

As shown in Figure 4.2, the LRM firmware can be downloaded using the Cattron FLASHBOX, as the rest of Unity products family. A proper adapter needs to be used to fit to the LRM host interface connector.

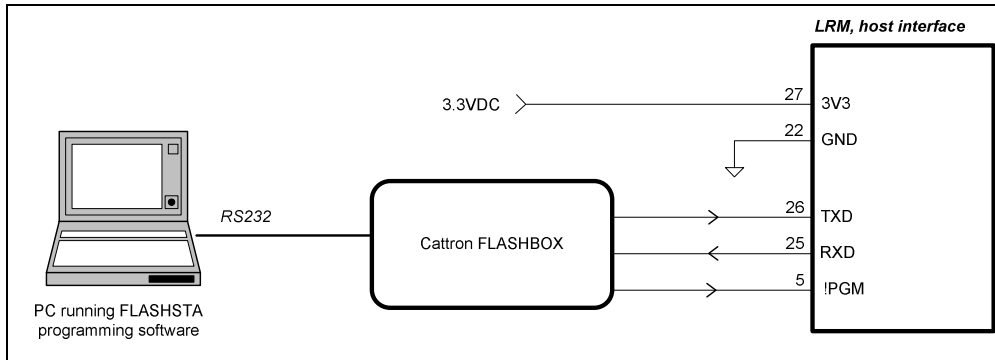

**Figure 4.2 - LRM firmware programming setup using the FLASHBOX**

## 5. Registers Map Summary

### 5.1 Registers description fields

The registers are specified by the following parameters

1. **Register address:** This address can be used from the console, I2C or SPI accesses.
2. **Parameter type:**

TYPE	Description
BOOL	Boolean value: 0 or 1
UINT8	8 bits value, unsigned
INT8	8 bits value, signed
UINT16	16 bits value, unsigned
INT16	16 bits value, signed
UINT32	32 bits value, unsigned
INT32	32 bits value, signed
CHAR	ASCII-encoded character

3. **Array Size:** Number of instances of this register. Each instance is referred to by using the keyword appended with the instance number. Ex: *reg0, reg1, reg2, ....*
4. **Access Type:**

Access Type	Description
R	Read only
RW	Read/Write
WP	Write-protected
RWP	Read/Write-protected

“Write protected” registers cannot be written, unless the correct key code has been written in the *WP unlock key* register.

5. **Keyword:** keyword use for console access
6. **Description:** description printed on the console after a help command.

## 6. Registers

### 6.1 Section 1 Registers: Hardware Information Block

<i>Section 1: Hardware Information Block</i>						
<i>Addr</i>	<i>Type</i>	<i>Array Size</i>	<i>Access</i>	<i>Keyword</i>	<i>Description</i>	<i>Details</i>
0x00	UINT8	1	RWP	<i>id</i>	RF module ID	
0x04	CHAR	14	RWP	<i>hwpn</i>	HW Part Number	
0x12	CHAR	4	RWP	<i>hwrev</i>	HW Revision	
0x16	CHAR	16	RWP	<i>sn</i>	Serial Number	
0x26	UINT8	26	RWP	<i>sp</i>	Spare	<i>Reserved for future usage.</i>
0x40	UINT8	1	RWP	<i>cmdef</i>	Default operation mode	
0x43	UINT16	1	RWP	<i>crc</i>	HIB CRC (Hardware Info Block)	

This section is formatted according the standard Unity RF modules E2PROM data format, described in reference [3]. Hardware Information Block registers are write-protected; writes operations are allowed after the proper key code has been written in the WP unlock key register

#### 6.1.1 HW Part Number

Hardware part number is a 14 characters ASCII string formatted according to Cattron standard part number format; [4 digits prefix]-[4 digits number]-[4 digits suffix]. Example: “2PCA-7954-A001”

#### 6.1.2 HW Revision

This field is a 4 characters ASCII representation of the HW Revision. Cattron hardware parts revision is composed of 2 segments. The first segment is made of one or two letters followed with one or two optional numerical digits. revision. Examples: “PP3”, “A”

#### 6.1.3 Serial Number

A 16 digits field is reserved for serial numbers. Serial numbers format is not predefined.

#### 6.1.4 Default Operation mode

Default value for the LRM operation mode. LRM operation modes are described in section 6.

### 6.2 Section 2 Registers: Software Information Block

<i>Section 2: Software Information Block</i>						
<i>Addr</i>	<i>Type</i>	<i>Array Size</i>	<i>Access</i>	<i>Keyword</i>	<i>Description</i>	<i>Details</i>
0x46	CHAR	14	R	<i>swpn</i>	SW Part Number	Section 3.2.1
0x54	CHAR	10	R	<i>swrev</i>	SW Revision	Section 3.2.2
0x5E	UINT16	1	R	<i>mapver</i>	Register map version	Section 3.2.3

Software Information Block registers are read-only.

### 6.2.1 SW Part Number

Software part number is a 14 characters ASCII string formatted according to Cattron standard part number format; [4 digits prefix]-[4 digits number]-[4 digits suffix]. Example: “3SOF-7954-A001”

### 6.2.2 SW Revision

Software revision is given by 3 segments separated by commas. The segments are typically but not restricted to numbers. Ex: “3.12.7”, “1.2.7B”,

A 10 characters long field is defined..

### 6.2.3 Register Map Version number

This is number is represented by numerical values. Ex: 1.34;

- The second segment is incremented each time new registers are added to the Register map, and this addition has no impact on backward compatibility. It is encoded on in the LSB.
- The first segment is incremented each time a change to the Register Map has any impact on backward compatibility. It is encoded in the MSB.

For example, “1.34” would be encoded as 0x0122.

## 6.3 Section 5 Registers: RF Interface Configuration

These parameters control the operation of the RF interface.

<b>Section 5: RF Interface Configuration</b>						
<b>Addr</b>	<b>Type</b>	<b>Array Size</b>	<b>Access</b>	<b>Keyword</b>	<b>Description</b>	<b>Details</b>
0x80	UINT32	1	RW	<b>txf</b>	Tx Frequency (Hz)	The new frequency is set at the next transition to Tx mode
0x84	UINT32	1	RW	<b>rxf</b>	Rx Frequency (Hz)	The new frequency is set at the next transition to Rx mode
0x88	INT8	1	RW	<b>txp</b>	Tx Level(dBm)	If the Tx level value is outside the range supported by the radio, the nearest supported value is set and readback.
0x8a	INT8	1	R	<b>rssi</b>	Current RSSI (dBm)	Reads current RSSI at frequency rxf. (Note: the LRM shall be in Rx mode)
0x8b	INT8	1	R	<b>prssi</b>	RSSI of last received packet (dBm)	
0x8c	UINT8	1	RW	<b>psize</b>	Max size of received packets	In number of bytes

## 6.4 Section 7 Registers: Test commands and parameters

This section implements tests utilities that can be used for development, production and service.



**Section 7: Test Commands and Parameters**

- Registers content after system reset is zero

<i>Addr</i>	<i>Type</i>	<i>Size</i>	<i>Access</i>	<i>Keyword</i>	<i>Description</i>	<i>Details</i>
0xe0	UINT8	1	W	<b>test</b>	Test Mode	
0xe4	UINT32	7	RW	<b>testp</b>	Test Parameters	

## 7. Test-Specific Parameters

Test Mode	value	Parameters
NO_TEST	0	None
TX_CW	1	None
TX_1010	2	None
TX_PRBS	3	None
TX_PACKETS_RANDOM	4	None
TX_PACKETS_PDEFINED	5	testp0: packet data
RX_RSSI	81	None
RX_STATS	82	None
RX_PACKETS	83	None
RX_BERO	84	testp0: Calculation window, in msec (default = 200msec). Result is printed after each window time. testp1: Calculation result from the last window
RX_BER1	85	testp0: Calculation window, in msec (default = 200msec) testp1: Calculation result from the last window