



REMOTE CONTROL AND TELEMETRY SYSTEMS

RCS200

Radio Remote Control System

User's Manual

This manual covers the following Remtron models:

RCT200 Transmitter
RCR200 Receiver

File: RCS200
Rev. A 2-08-00

REMTRON, INC. 1916 W. Mission Rd., Escondido, CA 92029-1114
PHONE 760-737-7800 FAX 760-737-7810

WARNING

SAFETY PROCEDURES

Safety is an extremely high priority in every remote control system designed and manufactured by Remtron. Although every effort has been made to provide a product with the most complete array of safety features, each application has its own unique requirements.

Remtron and its agents cannot be held responsible, for any breach of safety, carelessness, improper or unauthorized use of the remote control system or the equipment it is intended to control. Each customer is responsible for safe and proper use of the equipment. Each customer is also responsible that the employees involved with this equipment know, understand and use proper installation, operating and maintenance procedures and that they are aware of and adhere to all established safety rules and regulations as they apply.

1.1 INTRODUCTION

The RCS200 is a digital remote control system for applications that require a high level of reliability and integrity. It is designed for short range, license free operation of industrial and commercial equipment.

Intended primarily for OEM applications, the number of functions and the receiver interface is determined by the user's application.

1.2 SYSTEM DESCRIPTION

The basic system consists of an RCT200 Transmitter and an RCR200 Receiver. The signal format consists of a Amplitude Shift Keyed (ASK) signal that carries a 24 bit address, 8 data bits and is verified through a 16 bit CRC check word. Data is transmitted using Manchester format at a 4800 baud rate.

The address is permanently programmed into the transmitter at the factory and cannot modified. The receiver uses a learn mode to copy the address code from a transmitter and store it in memory.

1.3 TRANSMITTER DESCRIPTION

The transmitter is housed in a plastic case with membrane switches for control inputs. Inputs are encoded by a microprocessor and transmitted using burst mode ASK.

Figure 1-1 shows a block diagram of the transmitter. When a switch is activated, power is applied to the transmitter. The microprocessor encodes and sends a packet containing the address, data and CRC check word to the Transmitter IC. The packet is repeated every 60 m-sec as long as any switch is activated. When all switches are released, power is removed from the transmitter.

The transmitter IC is an integrated frequency multiplying PLL with a power output stage. It uses a fixed ÷ 32 prescaler so the output frequency is set at 32 times the reference crystal. The transmitter antenna consists of a matched loop on the circuit board.

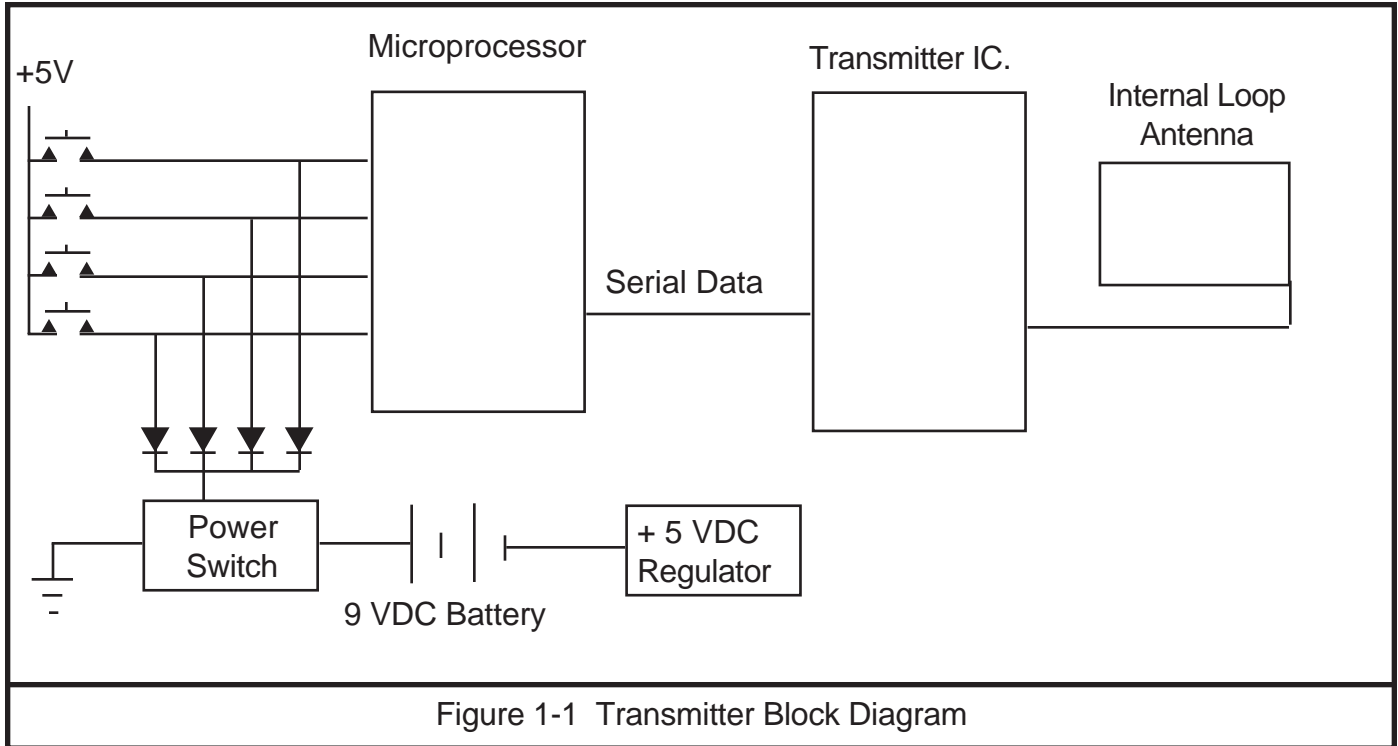

Figure 1-1 Transmitter Block Diagram

The Transmitter IC has a sleep mode which is used to conserve battery power. Each time a packet is sent, the transmitter is enabled 6 m-sec before modulation is applied to allow it to stabilize. After the data is sent, the transmitter again enters the sleep mode. The transmitter is therefore enabled approximately 20% of the time it is transmitting data.

1.4 RECEIVER DESCRIPTION

The receiver consists of an ASK receiver and a microprocessor with up to four output relays. The receiver is powered from 12 or 24 VDC.

Received data is passed directly to the microprocessor where the Manchester signal is decoded. The data packet is examined for an address match with the stored address, and correct CRC check. If both the address and the CRC are correct, the data is decoded and the output relay states are updated.

The microprocessor contains a nonvolatile memory (EEPROM) that retains the address and particular operating parameters for the system. The output

relays are factory programmed for the desired operation. The simplest configuration closes each relay as long as the corresponding switch on the transmitter is depressed. Complex and interactive relay logic is possible.

Safety Features

Each transmission goes through several checks to insure that the information being received is error free, including a 16 bit CRC test.

Over 16 million address codes means that no two systems will ever be produced with the same code, thereby insuring that no transmitter will ever be able to unintentionally control another piece of equipment.

Diagnostics

A number of optional diagnostic LEDs can be provided to aid in troubleshooting the radio control system.

1.5 SPECIFICATIONS

Table 2.1 Lists the specifications for the system.

SECTION 1 GENERAL

Table 1.1 Specifications

System

Operating frequency band	433 MHz
Available Channels	5 Channels
Number of Commands	8 maximum*
Modulation	Digital ASK with 24 bit address plus 16 bit CRC
Ambient Operating Conditions	- 20° F to +160° F

Transmitter

Power requirements	9V battery. Alkaline recommended.
Antenna	Internal
Switch Types	Membrane.
Transmitter case dimensions	4.5 X 2.7 X 1.25 Inches

RECEIVER

Power input	12/24 VDC
Receiver type	ASK
Antenna	External*
Logic Base	Microprocessor controlled
Response time	60 milliseconds
Output rating (relay)	5 Amp @ 12 VDC
Receiver cabinet	4.125 X 2.75 X 1.0 Inches

* Receiver antenna and configuration depends on system requirements.

SECTION 5 SERVICE & WARRANTY INFORMATION

5.1 SERVICE

Repairs

Products in need of repair may be returned to your dealer or sent directly to the factory at the address listed below. We recommend calling the factory for a Return Material Authorization (RMA) number prior to sending in the equipment. A note should be included describing the nature of the problem and the conditions under which the problem occurred. Also included with the returned product, should be the name, address and phone number where the product is to be returned and the name and phone number of a person familiar with the problem, who we may contact should the need arise. Products should be returned to:

Remtron, Inc.
1916 Mission Rd.
Escondido, CA 92029-1114

PH 760-737-7800

5.3 WARRANTY

Remtron, Inc. warrants its products to be free from defects in material and workmanship for a period of one (1) year from the date of the original invoice. In event of a defect or failure to perform as specified, Remtron will, at its discretion, repair or replace the product or refund the purchase price, prorated over the time the product was in use.

This warranty is void if the product was used in other than its normal and customary manner or subjected to misuse, neglect, accident, physical damage or was altered or tampered with by unauthorized personnel.

This warranty does not cover the cost of shipping and handling of the product from the customers' location to the factory.

This warranty gives you specific legal rights and you may also have other rights which vary from state to state.