



## PROTEUS™ HYBRID



The PROTEUS HYBRID™ an IP65 rated 3-in-1 hybrid moving head luminaire, which can be used as a spot, beam, or wash fixture. Features include an advanced optical system with motorized zoom from 2° in beam mode to 38° in spot mode or 40° in wash mode, a advanced internal thermal cooling system, full CMY and linear CTO color mixing, 14 dichroic colors including CTB, CTO, and UV, 8 rotating interchangeable and 14 static-stamped metal gobos, full 360° bi-directional animation wheel, rotating prisms and frost filter, motorized focus and auto-focus, high speed mechanical shutter and strobe, DMX, RDM (Remote Device Management), Art-NET, and sACN protocol support, Elation's E-FLY™ internal wireless DMX transceiver, IP rated 5pin XLR and RJ45 etherCON in/out connections, powerCON TRUE1 power in, full color 180° reversible menu display with 6 button touch control panel, battery backup for display power, and a multi-voltage universal auto switching power supply (100-240v).

### FEATURES

- IP65 Rated Hybrid Spot, Beam, Wash 3-in-1 Luminaire**
- 470W 8,000K Lamp and Advanced Optics**
- Spot, Beam and Wash Modes**
- Motorized Zoom from 2° Beam to 38° Spot or 40° Wash**
- Advanced Internal Thermal Cooling System**
- Full CMY Color Mixing and Linear CTO Color Correction**
- 14 Dichroic Colors including CTB, CTO, and UV**
- 8 Rotating Interchangeable and 14 Static-Stamped Gobos**
- Full 360° Bi-Directional Animation Wheel**
- 8 Facet and Linear Rotating Prisms and Wash Frost Effects**
- Motorized Focus and Auto-Focus**
- High Speed Mechanical Shutter and Strobe**
- DMX, RDM, Art-NET, and sACN Support**
- Elation's E-FLY™ Internal Wireless DMX Transceiver**

Specifications are subject to change without notice ©Elation Professional 11/08/17

Elation Professional USA | 6122 S. Eastern Ave. | Los Angeles, CA. 90040  
323-582-3322 | 323-832-9142 fax | [www.elationlighting.com](http://www.elationlighting.com) | [info@elationlighting.com](mailto:info@elationlighting.com)

Elation Professional B.V. | Junostraat 2 | 6468 EW Kerkrade, The Netherlands  
+31 45 546 85 66 | +31 45 546 85 96 fax | [www.elationlighting.eu](http://www.elationlighting.eu) | [info@elationlighting.eu](mailto:info@elationlighting.eu)



**PRODUCT SPECIFICATIONS**

**SOURCE**

Philips MSD Platinum 21R 470W 8,000K Lamp  
1,000 Hour Average Lamp Life\*

\*Lamp Life may vary depending on several factors including but not limited to: Environmental Conditions, Power/Voltage, Usage Patterns (On-Off Cycling), Control and Dimming.

**PHOTOMETRIC DATA**

80CRI | >23,000 Lumens  
13,375 LUX 1,243 FC @49.2' (15m) (3.0° Spot)  
233,000 LUX 21,646 FC @49.2' (15m) (2.0° Beam)  
11,500 LUX 1,068 FC @16.4' (15m) (4.0° Wash)

**EFFECTS**

Full 360° Bi-Directional Animation Wheel  
8 Facet and Linear Rotating Prisms and Prism Macros  
Frost Filter Hybrid Wash Effect  
Motorized Focus and Auto-Focus  
High Speed Mechanical Shutter and Strobe

**COLOR**

14 Dichroic Colors including CTB, CTO, and UV  
Full CMY Color Mixing and Linear CTO Color Correction

**GOBOS**

(8) Interchangeable Rotating / Indexing Glass Gobos  
(14) Static-Stamped Metal Gobos

**CONTROL / CONNECTIONS**

(3) DMX Channel Modes (37 total channels)  
6 Button Touch Control Panel  
Full Color 180° Reversible LCD Menu Display  
8 / 16 Bit Resolution Adjustable Movement  
DMX, RDM, Art-NET and sACN Protocol Support  
Elation E-FLY™ Internal Wireless DMX Transceiver  
IP65 5pin DMX, RJ45 Ethernet In/Out (Art-NET, sACN)  
IP65 powerCON TRUE1 Power In

**SIZE / WEIGHT**

Length: 18.2" (462mm)  
Width: 22.5" (572mm)  
Vertical Height: 31.5" (800mm)  
Weight: 84.0 lbs. (38.0 kg)

**ELECTRICAL / THERMAL**

AC 100-240V - 50/60Hz  
700W Max Power Consumption  
14°F to 113°F (-10°C to 45°C)

**APPROVALS / RATINGS**



**ORDERING INFORMATION**

PRB021	PROTEUS HYBRID™
DRCPROHYBRID1	Single Road Case For PROTEUS HYBRID
DRCPROHYBX2W	Dual Road Case For PROTEUS HYBRID
TRIGGER CLAMP	Heavy Duty Wrap Around Hook Style Clamp
EFL001	E-FLY™ Wireless DMX Transceiver
SCABLE60	24" (610mm) 60 lbs. (27 kg) Rated Safety Cable

**PHOTOMETRIC DATA**

<b>SPOT MODE</b>	<b>15 m</b>	<b>49.2 ft</b>	<b>SPOT MODE</b>	<b>15 m</b>	<b>16.4 ft</b>
3.0° Min	0.73	2.4	29.0° Max	7.65	25.1
	lux	fc		lux	fc
<b>FULL ON</b>	<b>61,670</b>	<b>5,729</b>	<b>FULL ON</b>	<b>679</b>	<b>63</b>
<b>BEAM MODE</b>	<b>15 m</b>	<b>49.2 ft</b>	<b>BEAM MODE</b>	<b>15 m</b>	<b>16.4 ft</b>
2.0° Min	0.56	1.8	22.0° Max	2.76	9.1
	lux	fc		lux	fc
<b>FULL ON</b>	<b>233,000</b>	<b>21,646</b>	<b>FULL ON</b>	<b>2,712</b>	<b>252</b>
<b>WASH MODE</b>	<b>15 m</b>	<b>49.2 ft</b>	<b>WASH MODE</b>	<b>15 m</b>	<b>49.2 ft</b>
4.0° Min	1.05	3.4	32.0° Max	8.37	27.5
	lux	fc		lux	fc
<b>FULL ON</b>	<b>33,340</b>	<b>3,097</b>	<b>FULL ON</b>	<b>626</b>	<b>58</b>

**COLORS AND GOBOS**

**COLOR FLAGS**



**COLOR WHEEL**



**INTERCHANGEABLE-ROTATING GOBO WHEEL 1**



**STATIC-FIXED GOBO WHEEL 2**



**\*\*IMPORTANT NOTICE REGARDING GOBO DIMENSIONS AND CUSTOM GOBOS\*\***  
Due to the extreme high temp optical system, special material and design requirements are required. Please contact ELATION Customer Support for specific details.

**DIMENSIONAL DIAGRAMS**

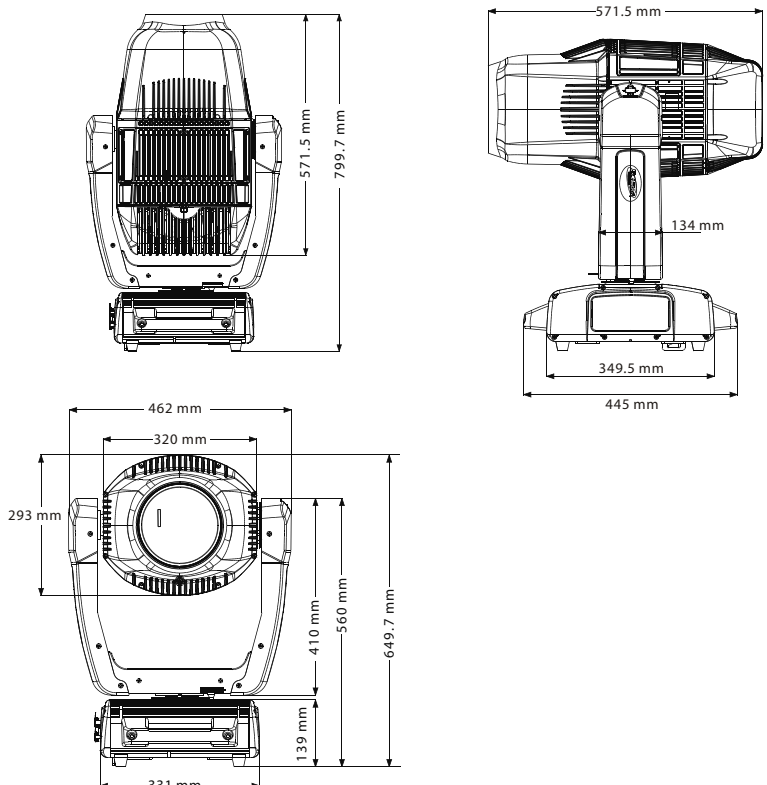

Specifications are subject to change without notice ©Elation Professional 1107/17

