



Fusion4Home™ 3.0

Voice and 4G Data Booster Kit for Home and Office

User Guide



Introduction

Thank you for purchasing SureCall's Fusion4Home 3.0 cellular signal booster kit. SureCall's Fusion4Home was specifically designed to eliminate frustrations over dropped calls and limited range by amplifying incoming and outgoing cellular signals in homes and offices.

If you have any questions during setup, please reach out to our US-based experienced support technicians:

Call: 1-888-365-6283

Email: support@surecall.com

Visit: www.surecall.com/support



Watch installation, optimization and troubleshooting techniques on our SureCall YouTube channel



[@SureCall](https://twitter.com/SureCall)



Stay up to date with all things SureCall

TABLE OF CONTENTS

How it works	4
PACKAGE CONTENTS.....	4
BEFORE INSTALLATION.....	6
Installation Overview	6
INSTALLATION	6
Step 1. Find the Area With the Strongest Signal.....	6
Step 2. Install the Outside Antenna.....	7
Step 3. Install the Booster and Inside Antenna.	10
Step 4: Connect to Power and Turn On	12
Step 5: Configure Gain Settings If Needed	12
IF YOU WANT TO IMPROVE PERFORMANCE.....	12
LED INDICATORS.....	13
TROUBLESHOOTING	14
SPECIFICATIONS.....	14
USER GUIDELINES.....	16
WARRANTY	17
Three-Year Product Warranty	17

How It Works

How it works

1. An outside antenna collects signal from the cell tower.
2. The outside antenna sends the signal to the booster through coax cable.
3. The booster amplifies the cell signal and rebroadcasts the signal indoors from via the inside antenna to all mobile devices within range.
4. The system also works in reverse amplifying outgoing signal back to the tower.

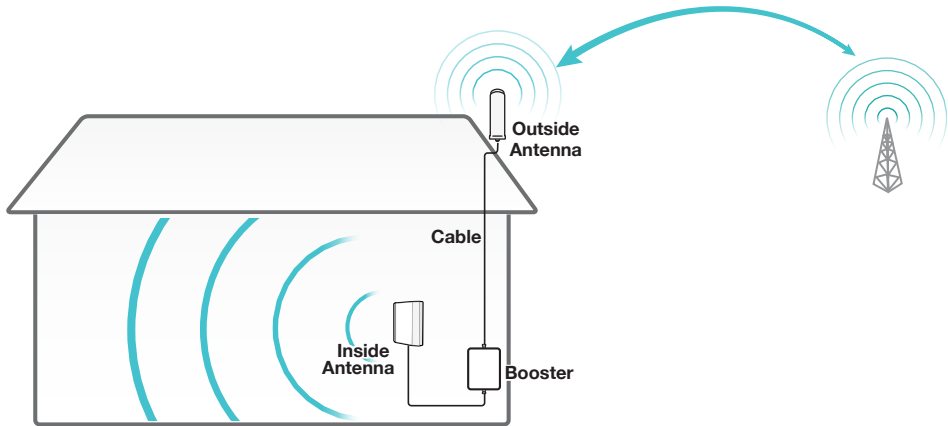

How the SureCall Fusion4Home 3.0 Booster Works

PACKAGE CONTENTS

Unpack all package contents. For missing or damaged items, contact your reseller.

Turn over the signal booster and record the model and serial number for reference:

Serial #: _____

Purchase Date: _____

Keep the carton and packing material to store the product in case you need to return.

Your Fusion4Home 3.0 signal booster package includes the following items:

1. SureCall Fusion4Home signal booster and power supply
2. Cable for connecting the outside antenna to the signal booster (RG6, 50 ft)
3. Cable for connecting the booster to the inside antenna (SC-240, 20 ft)
4. One outside antenna (either omni or Yagi antenna)
5. One Inside antenna (either omni-directional whip or directional panel antenna)

1. Fusion4Home Cellular Booster and power supply



2. Outside Cable (50 ft)



3. Inside Cable (20 ft.)



4. Outside Antenna Options:

4.a Outside Omni « OR » 4.b Outside Yagi Antenna



5. Inside Antenna Options:

5.a Inside Omni « OR » 5.b Inside Directional Panel Antenna



Warning: Changes or modifications not expressly approved by SureCall could void the user's authority to operate the equipment.

BEFORE INSTALLATION

1. Prior to securing the location of any booster parts, a “soft install” is recommended as adjustments may be needed to optimize performance.
2. Ensure adequate separation between the planned locations of the inside and outside antenna – at least 25 ft (see diagram “Antenna Separation” on page 7).
3. For kits that use directional antennas (outside or inside), the directional antenna(s) should be oriented in a way that they do not “face” the other antenna (see “Aiming Directional Antennas” Diagram).
4. Ensure sufficient cable length between the outside antenna location and booster location. The length of the provided cable is 50 ft.

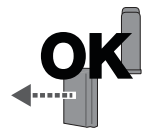
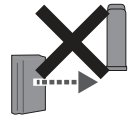

Aiming Directional Antennas

Installation Overview

- Step 1. Find the outside area with the strongest signal.
- Step 2. Install the outside antenna identified in step 1.
- Step 3. Install the Inside antenna and booster.
- Step 4. Connect power source and turn on.
- Step 5. Configure gain settings if needed.

INSTALLATION

Step 1. Find the Area With the Strongest Signal

Using your phone, identify the outside location with the strongest signal for placement of your outside antenna. Generally, this is found above the roofline on the side facing your nearest cell tower and as high as possible – where the antenna can ‘see’ your cell tower. To find the location of your carrier’s closest cell tower, go to www.antennasearch.com.

The coverage area that the booster provides is directly related to the strength of incoming signal received by the outdoor antenna. Mounting the outside antenna where the signal is the strongest will provide the best results. **Please note**, as seen in the table below, if signal is extremely weak where the outside antenna is installed, indoor coverage will be limited.

Estimated coverage:

Outdoor signal strength (dB)	1-2 Bars (-85 to -95)	3-4 Bars (-75 to -84)	5 Bars (-65 to -74)
Fusion4Home Omni/Whip Kit Estimated coverage (sq. ft.)	500	1000	2,000
Fusion4Home Yagi/Whip Kit Estimated coverage (sq. ft.)	1000	2,000	4,000
Fusion4Home Yagi/Panel Kit Estimated coverage (sq. ft.)	1,500	3,000	6,000

Note that Bars are not always a reliable measure of signal. The best way to confirm signal coverage is the ability to place and hold a call.

Putting your phone in Field Test mode will also indicate what level of decibels (dB) your phone is currently receiving. Decibels are measured in the negatives, and a score closer to zero indicates you have a better signal. A signal of -120 dB indicates you have no service, while a score of about -50 dB means you have excellent signal strength

For specific dB signal measurements, use the methods below.

- Apple iPhones: Dial *3001#12345#* and press Call. In the top-left corner, a dB number appears instead of bars.
- Android devices: download the app “Network Signal Info” in the Google Play store.

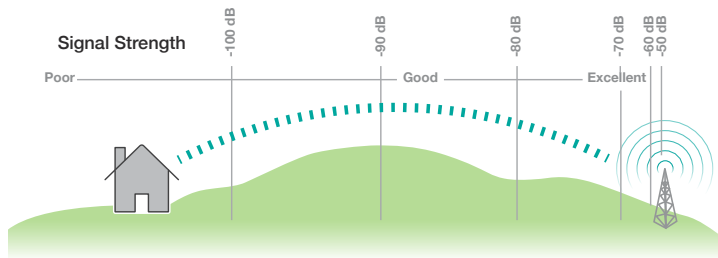

Step 2. Install the Outside Antenna

After identifying the area of strongest signal, choose the surface where you will mount your outside antenna.

The location should allow for sufficient separation between the outside antenna and inside antenna. Vertical separation is preferred as it is more effective than horizontal separation.

The minimum separating distance recommended is 25 vertical feet; however, increased separation, up to 40 - 60 ft, may be needed, especially where vertical separation cannot be achieved.

Option A: Omni Antenna

The omni antenna is omni-directional, which receives and sends signals in a 360° radius. The provided hardware allow for either a surface mount or pole-mount.

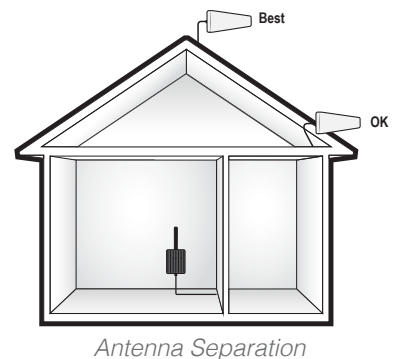

Warning: Do not collocate antennas or operate the outdoor antenna with any other antenna or signal booster.

Installation



Option A:
Omni Antenna



Option B:
Yagi Antenna

Mount antenna to a vertical surface:

1. Using vertical plate of bracket, mark position of desired placement. The omni antenna should be mounted in an upright position (See “Omni Antenna Install Illustration”)
2. Unscrew nut from end of stucco screw and remove it along with lock washer and regular washer.
3. Place vertical L-bracket plate into desired location and tap the screws, head first, along with sleeve, into stucco 1/2 to 5/8 inches deep into place.
4. In this order, place washer, lock washer and nut on each screw and tighten until secure. When tightening screw, sleeve will expand to secure plate.
5. Use provided screws to secure antenna base onto horizontal plate.
6. Connect antenna to one end of the provided RG6 cable and tighten the connection. Run the cable along route to planned location of your booster.



Omni antenna with
surface mount hardware



Pole-mount hardware

Note: Alternate screws may be required for differing surfaces such as wood or concrete.

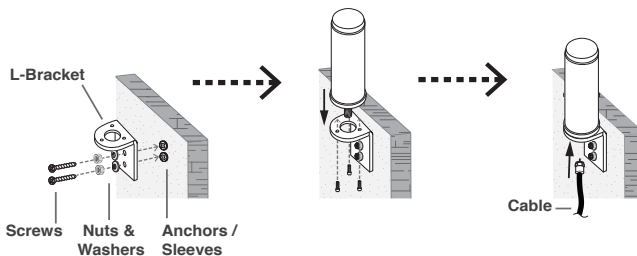

Omni Antenna Install Illustration

Option B: Outside Yagi Antenna

Before installing a Yagi, or directional antenna, note that the antenna should be mounted on a pole or pipe (not provided), at the highest possible location above the roofline – at least 25 ft above the indoor antenna – aimed in the direction of your nearest cell tower. To find the location of your carrier's closest cell tower, go to www.antennasearch.com.

Ensure that the mounting area has at least a 3 ft radius clear of obstructions, other radiating elements and metal objects such as pipes or metal siding and orient the antenna with the drip hole at the bottom.

Once you have identified your install location, assemble the u-bolt, bracket, nuts and washers onto a pole (available separately) as shown in the illustration. Keep the connections loose enough to allow the antenna to rotate until the optimum direction is found.

Once the outside antenna is secured to a pipe or pole, connect antenna to one end of the provided RG6 cable and tighten the connection. Run the cable along route to planned location of your booster.

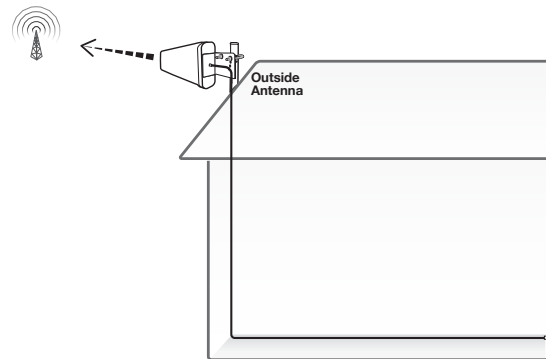
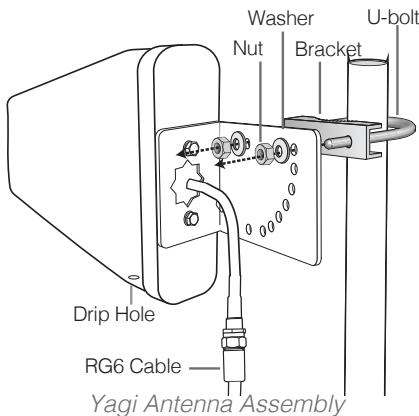

Yagi Antenna Install Illustration

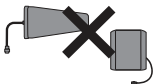

Aiming Directional Antennas

Caution: Do Not aim a directional antenna towards another antenna

Step 3. Install the Booster and Inside Antenna.

Choose a location for the booster and inside antenna that is near a working outlet and at least 25 Ft from the outside antenna. Consider the below factors affecting booster performance.

1. Signal strength at the location of the outside antenna.
2. Interior building materials between the inside antenna and your mobile device.
3. Distance between the outside antenna and inside antenna (minimum 25 ft. separation)

Note: This booster should not be used near open fire or flame. Storage and transportation: Store and place in non-extreme room-temperature and dry environment.



Option A:
Whip Antenna



Option B:
Panel Antenna

Option A: Whip Antenna

Place the booster in a central location where signal is needed. When placing the booster, note that further separation between the booster and outside antenna will increase booster performance. Connect the whip antenna to the booster connector labeled INSIDE.

Whether you choose to mount the booster on a wall or set on a shelf, note that the antenna should be vertical.

Option B: Panel Antenna

SureCall's Inside panel antennas are directional with a 120° reach. They should be mounted facing the area signal is needed and away from the outdoor antenna (See "Aiming Directional Antennas" on page 6).

Mount on a vertical surface that is the approximate height of normal cell phone use. The antenna may be concealed behind a wall provided there are no materials that could obstruct signals.

Besides the antenna itself, parts include mounting equipment for a flat horizontal surface.

1. Using plate, mark position of desired screw placement.
2. Screw mounting plate into place with the slide panel protruding towards you.
3. Slide antenna securely onto mounting plate.

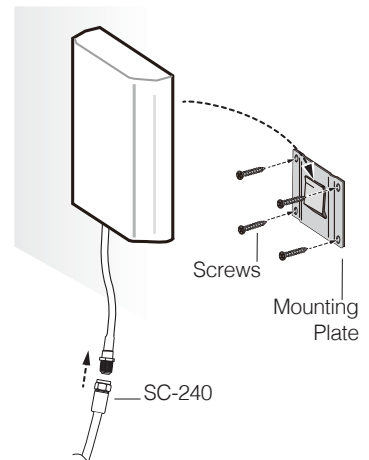

4. Connect antenna to one end of the SC-240 cable and run to planned location of your booster
5. Place the booster on a flat surface or mounted to a wall and connect the remaining end of the SC-240 cable to booster port marked INSIDE.

Place the Booster

To install the booster to a wall, select a location that is near a working AC outlet. Use the supplied screws or appropriate screws for surface of mounting location and drill through screw tab holes on booster (see “Booster Diagram” illustration) and mount the booster to a wall.

Next, connect the outside antenna and booster by connecting the open end of the 50 ft. cable leading from the outside antenna to the port of the booster marked “OUTSIDE”.

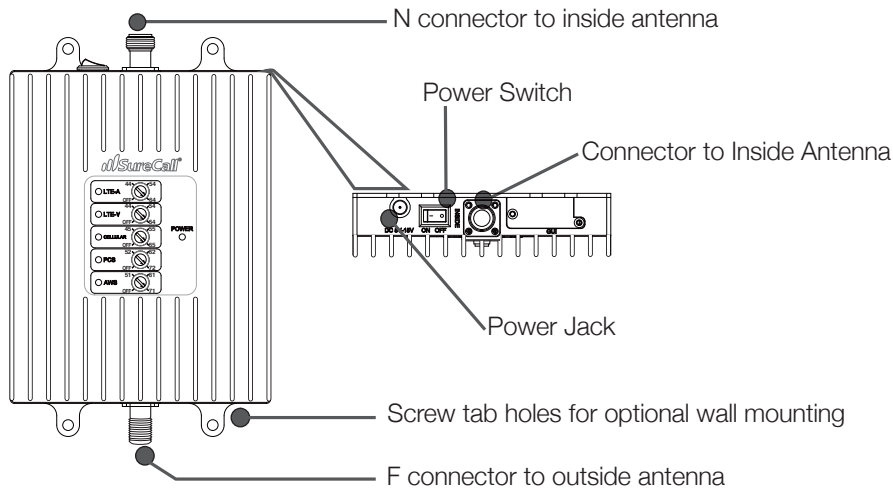

Booster Diagram

IMPORTANT: FCC 27.5 (d)(4): Fixed, mobile, and portable (hand-held) stations operating in the 1710-1755 MHz band as well as mobile and portable stations operating in the 1695-1710 MHz and 1755-1780 MHz bands are limited to 1 watt EIRP.
Fixed stations operating in the 1710-1755 MHz band are limited to a maximum antenna height of 10 meters above ground.

Step 4: Connect to Power and Turn On

Connect the AC power cord to the booster and plug into a 110V AC power outlet. Once the booster has been completely assembled, turn the booster's power switch to ON.

Note: If the Power LED does not turn ON or the Alert LEDs continue to flash, see the "Troubleshooting" on page 14 section.

Note: This booster is rated for 5-15V input voltage. DO NOT use the booster with a higher voltage power supply. This can damage the booster, cause personal injury, and void your warranty.

Step 5: Configure Gain Settings If Needed

Place a call in the room where the inside antenna is located to confirm that your phone is receiving a boosted signal.

Note: Bars are not always a reliable measure of signal. The best way to confirm signal coverage is the ability to place and hold a call.

Booster gain dials or switches should always be at maximum level unless the control light for a specific frequency band is flashing red or flashing red-yellow. In either case, only reduce gain dials if the recommended actions found in "LED Indicators" on page 13 do not resolve the issue.

It is best to avoid turning the gain dial below 40 dB as this could cause affected frequency band to stop amplifying.

IF YOU WANT TO IMPROVE PERFORMANCE

- Identify a location outside that receives a stronger signal and move the outside antenna to that location (higher is usually better).
- Increase the distance between the booster and outside antenna - vertical separation is better than horizontal.
- If using an omni outside antenna, upgrade to a directional yagi antenna that can be aimed toward your closest tower.

LED INDICATORS

LED Color	LED Condition	Resolution
Yellow	Solid	Indicates that the frequency band is not being used. After a period of time, if there's no activity, that band will go into sleep mode. Light is off while band is active. This is part of normal operation.
Yellow	Flashing	Indicates that the Automatic Gain Control (AGC) is self-adjusting. This is part of normal operation.
Red	Flashing	Indicates that the booster is receiving too much signal which could cause the affected band to automatically turn off. When this happens: <ol style="list-style-type: none"> 1. For kits using an OMNI outside antenna, relocate the outside antenna to a location where the signal is weaker. 2. For kits using a YAGI outside antenna, turn the antenna in short increments away from the signal source. 3. Increase the separation between antennas (additional vertical separation works best). 4. Add an inline attenuator to the cable coming into the outside port of the booster. 5. Though not desirable as amplification will not be optimum, lower the dB gain setting in small increments until the light turns off or flashes yellow.
Red	Solid	The frequency band is off. If a red light has been flashing for an extended time due to too much signal, that frequency band will display a solid red light indicating that the circuitry for that frequency band has been turned off. This can also happen when the gain dial for a frequency band has been turned all the way down.
Yellow/ Red	Alternately Flashing	Self-oscillation has been detected and to prevent it, one or more of the frequency bands have shut down. If this happens: First, try increasing the separation between the inside and outside antennas. If your booster kit uses directional antennas (example: outside Yagi antenna and inside panel antenna), ensure that they are facing away from one another. If condition continues, lower the dB gain setting in small increments until the light turns off or flashes yellow.

TROUBLESHOOTING

If you have any questions during setup, please reach out to our US-based experienced support technicians:

Call: 1-888-365-6283

Email: support@surecall.com

Visit: www.surecall.com/support

Problem	Resolution
Signal booster has no power	Connect the power supply to an alternate power source. Verify that the power source is not controlled by a switch that has removed power from the outlet. If it remains OFF, contact tech support at: 1-888-365-6283 or support@surecall.com
After completing installation, indoor signal coverage has not improved	Verify that cable connections are tightly fitted to the booster and antenna. Try further separating the booster and antenna. Verify that there is usable signal where the antenna is placed. ⓘ Note: Bars are not always a reliable measure of signal. The best way to confirm signal coverage is the ability to place and hold a call.

SPECIFICATIONS

Model	Fusion4Home 3.0 (US), Fusion4Home 3.0 CA (Canada)
Uplink Frequency Range (MHz):	698-716 / 776 – 787 / 824-849 / 1850-1915 / 1710-1755 (G Block Included)
Downlink Frequency Range (MHz):	728-746 / 746 – 757 / 869-894 / 1930-1995 / 2110-2155 (G Block Included)
Maximum Gain:	72 dB
Supported Standards:	CDMA, WCDMA, GSM, EDGE, HSPA+, EVDO, LTE and all cellular standards
Input Impedance:	75Ω donor port / 50Ω server port
Noise Figure:	8 dB
AC Input:	Input AC110V, 60 Hz; Output DC 5-15V
Maximum Output Power:	1 Watt EIRP
Cable:	RG6 / SC-240
RF Connectors:	F Female (outdoor) / N Female (indoor)
Power Consumption:	<15W
Operation Temperature:	-4° to +158° F
Dimensions:	7.875 x 5 x 1.188 inches
Weight:	2 LB 3 oz
Certifications:	FCC ID: RSNF4HOME (US), IC: 7784A-F4HOME (Canada)

Note: The term "IC" before the radio certification number only signifies that Industry Canada technical specifications were met.

Kitting

Component	Product number	Gain/Loss					Note
		LTE-A 707 MHz	LTE-V 731 MHz	Cellular 800 MHz	PCS 1900 MHz	AWS 1700 / 2100 MHz	
Outdoor Antenna*	SC-289W-75Ω	3 dBi	3 dBi	3 dBi	4 dBi	4 dBi / 4 dBi	
	SC-231W-75Ω	7 dBi	7 dBi	8 dBi	10 dBi	10 dBi / 10 dBi	
Outdoor Cable*	RG6 - 50 (50')	3.32 dB	3.32 dB	3.75 dB	6.42 dB	6.22 dB / 6.68 dB	50 Feet or longer
Inside Cable*	SC-240-20NN (20')	2.06 dB	2.06 dB	2.29 dB	3.56 dB	3.36 dB / 3.76 dB	20 Feet or longer
Inside Antenna*	SC-248W	7 dBi	7 dBi	7 dBi	10 dBi	10 dBi / 10 dBi	
	SC-222W	3 dBi	3 dBi	3 dBi	6 dBi	6 dBi / 6 dBi	
	SC-121W	1.2 dBi	1.2 dBi	1.2 dBi	3 dBi	3 dBi / 3 dBi	
	SC-302W	2.5 dBi	2.5 dBi	3 dBi	5 dBi	4 dBi / 5 dBi	

* All equivalent antennas and cables are suitable for use with the Fusion4Home 3.0

PreAGC							
	Pulse GSM			4.1 MHz AWGN			Limit
Frequency (MHz)	Input (dBm)	Output (dBm)	Gain (dB)	Input (dBm)	Output (dBm)	Gain (dB)	Gain (dB)
Uplink: 1710-1755	-48.9	20.8	69.7	-48.2	21.6	69.8	71.3
Uplink: 1850-1915	-50.3	20.4	70.7	-47.6	20.6	68.2	72.0
Uplink: 824-849	-34.9	25.1	60.0	-35.5	24.1	59.6	64.9
Uplink: 698-716	-33.6	25.7	59.3	-36.2	24.4	60.6	63.5
Uplink: 777-787	-31.8	26.0	57.8	-35.8	25.4	61.2	64.4
Downlink: 2110-2155	-61.4	9.2	70.6	-60.6	9.1	69.7	N/A
Downlink: 1930-1995	-59.2	7.9	67.1	-58.0	8.5	66.5	N/A
Downlink: 869-894	-56.0	8.2	64.2	-56.5	6.4	62.9	N/A
Downlink: 728-746	-54.8	6.2	61.0	-57.3	3.7	61.0	N/A
Downlink: 746-757	-53.8	8.0	61.8	-54.7	6.4	61.1	N/A

Warning: Any product modifications that use unauthorized antennas, cables, and/or coupling devices are prohibited by the FCC. Contact FCC for details: 1-888-CALL-FCC. Changes or modifications not expressly approved by SureCall could void the user's authority to operate the equipment.

USER GUIDELINES

This is a CONSUMER device

BEFORE USE, you **MUST REGISTER THIS DEVICE** with your wireless provider and have your provider's consent. Most wireless providers consent to the use of signal boosters. Some providers may not consent to the use of this device on their network. If you are unsure, contact your provider.

In Canada, **BEFORE USE** you must meet all requirements set out in ISED [CPC-2-1-05](#)¹

You **MUST** operate this device with approved antennas and cables as specified by the manufacturer. Antennas **MUST** be installed at least 20 cm (8 inches) from (i.e. **MUST NOT** be installed within 20 cm of) any person.

You **MUST** cease operation of this device immediately if requested by the FCC (or ISED in Canada) or a licensed wireless service provider.

WARNING: E911 location information may not be provided or may be inaccurate for calls served by using this device.

This device may be operated **ONLY** in a fixed location, for in-building use.

Ce produit est un appareil de CONSOMMATION

AVANT DE L'UTILISER, vous **DEVEZ ENREGISTRER CE DISPOSITIF** auprès de votre fournisseur de services cellulaires et obtenir son consentement. La plupart des fournisseurs de services cellulaires autorisent l'utilisation d'amplificateurs de signal. Il se peut que certains fournisseurs n'autorisent pas l'utilisation de ce dispositif sur leur réseau. Si vous n'êtes pas sûr, contactez-le.

Au Canada, **AVANT DE L'UTILISER** vous devez répondre à toutes les exigences ISED [CPC-2-1-05](#)²

Vous **DEVEZ** utiliser ce dispositif avec les antennes et les câbles autorisés, tel que le spécifie le fabricant. Les antennes **DOIVENT** être installées à au moins 20 cm (8 po) (**NE DOIVENT PAS** être installées à moins de 20 cm) de toute personne avoisinante.

Vous **DEVEZ** arrêter cet appareil immédiatement à la demande de la FCC (ISED au Canada) ou de tout fournisseur de services cellulaires autorisé.

AVERTISSEMENT: Il se peut que les informations relatives à la localisation E911 ne soient pas disponibles ou soient inexactes pour les appels qui utilisent cet appareil.

Cet appareil peut fonctionner seulement à un emplacement fixe à l'intérieur d'un bâtiment;

Register your cellular booster with your wireless carrier at the following urls:

Verizon: <http://www.verizonwireless.com/wcms/consumer/register-signal-booster.html>

AT&T: <https://securec45.securewebsession.com/attsignalbooster.com/>

T-Mobile: <https://support.t-mobile.com/docs/DOC-9827>

Sprint: https://www.sprint.com/legal/fcc_boosters.html

U.S. Cellular: <http://www.uscellular.com/uscellular/support/fcc-booster-registration.jsp>

This device complies with Part 15 of FCC Rules. Operation is subject to the following two conditions: (1) this device may not cause harmful interference, and (2) this device must accept any interference received, including interference that may cause undesired operation.

CAN ICES-3 (B)/NMB-3(B) (Canada) :

This Class B digital apparatus meets all requirements of the Canadian Interference Causing Equipment Regulations. Operation is subject to the following two conditions: (1) this device may not cause harmful interference, and (2) this device must accept any interference received, including interference that may cause undesired operation

The Manufacturer's rated output power of this equipment is for single carrier operation. For situations when multiple carrier signals are present, the rating would have to be reduced by 3.5 dB, especially where the output signal is re-radiated and can cause interference to adjacent band users. This power reduction is to be by means of input power or gain reduction and not by an attenuator at the output of the device.

Cet appareillage numérique de la classe B répond à toutes les exigences de l'interférence canadienne causant des réglemments d'équipement. L'opération est sujette aux deux conditions suivantes: (1) ce dispositif peut ne pas causer l'interférence nocive, et (2) ce dispositif doit accepter n'importe quelle interférence reçue, y compris l'interférence qui peut causer l'opération peu désirée.

La puissance de sortie nominale indiquée par le fabricant pour cet appareil concerne son fonctionnement avec porteuse unique. Pour des appareils avec porteuses multiples, on doit réduire la valeur nominale de 3,5 dB, surtout si le signal de sortie est retransmis et qu'il peut causer du brouillage aux utilisateurs de bandes adjacentes. Une telle réduction doit porter sur la puissance d'entrée ou sur le gain, et ne doit pas se faire au moyen d'un atténuateur raccordé à la sortie du dispositif.

1 For details on the requirements specified in ISED CPC-2-1-05, visit: <http://www.ic.gc.ca/eic/site/smt-gst.nsf/eng/sf08942.html>

2 Pour plus de détails sur les exigences ISED CPC-2-1-05, reportez-vous au site: <http://www.ic.gc.ca/eic/site/smt-gst.nsf/eng/sf08942.html>

WARRANTY

Three-Year Product Warranty

To activate your three-year manufacturer's warranty, register your SureCall product at www.SureCall.com

SureCall warrants its products for three years from the date of purchase against defects in workmanship and/or materials. Specifications are subject to change. The three-year warranty only applies to products meeting the latest FCC Certification Guidelines stated on 2/20/2013 and going into effect April 30, 2014. A two-year warranty applies to any products manufactured before May 1, 2014.

Products returned by customers must be in their original, un-modified condition, shipped in the original or protective packaging with proof-of-purchase documentation enclosed, and a Return Merchandise Authorization (RMA) number printed clearly on the outside of the shipping container.

Buyers may obtain an RMA number for warranty returns by calling the SureCall Return Department toll-free at 1-888-365-6283. Any returns received by SureCall without an RMA number clearly printed on the outside of the shipping container will be returned to sender. In order to receive full credit for signal boosters, all accessories originally included in the signal booster box must be returned with the signal booster. (The Buyer does not need to include accessories sold in addition to the signal booster, such as antennas or cables.)

This warranty does not apply to any product determined by SureCall to have been subjected to misuse, abuse, neglect, or mishandling that alters or damages the product's physical or electronic properties.

SureCall warrants to the Buyer that each of its products, when shipped, will be free from defects in material and workmanship, and will perform in full accordance with applicable specifications. The limit of liability under this warranty is, at SureCall's option, to repair or replace any product or part thereof which was purchased up to THREE YEARS after May 1, 2014 or TWO YEARS for products purchased before May 1, 2014, as determined by examination by SureCall, prove defective in material and/or workmanship. Warranty returns must first be authorized in writing by SureCall. Disassembly of any SureCall product by anyone other than an authorized representative of SureCall voids this warranty in its entirety. SureCall reserves the right to make changes in any of its products without incurring any obligation to make the same changes on previously delivered products.

As a condition to the warranties provided for herein, the Buyer will prepay the shipping charges for all products returned to SureCall for repair, and SureCall will pay the return shipping with the exception of products returned from outside the United States, in which case the Buyer will pay the shipping charges.

The Buyer will pay the cost of inspecting and testing any goods returned under the warranty or otherwise, which are found to meet the applicable specifications or which are not defective or not covered by this warranty.

Products sold by SureCall shall not be considered defective or non-conforming to the Buyer's order if they satisfactorily fulfill the performance requirements that were published in the product specification literature, or in accordance with samples provided by SureCall. This warranty shall not apply to any products or parts thereof which have been subject to accident, negligence, alteration, abuse, or misuse. SureCall makes no warranty whatsoever in respect to accessories or parts not supplied by it.

Limitations of Warranty, Damages and Liability:

EXCEPT AS EXPRESSLY SET FORTH HEREIN, THERE ARE NO WARRANTIES, CONDITIONS, GUARANTEES, OR REPRESENTATIONS AS TO MERCHANTABILITY, FITNESS FOR A PARTICULAR PURPOSE, OR OTHER WARRANTIES, CONDITIONS, GUARANTEES, OR REPRESENTATIONS, WHETHER EXPRESSED OR IMPLIED, IN LAW OR IN FACT, ORAL OR IN WRITING.

SURECALL AGGREGATE LIABILITY IN DAMAGES OR OTHERWISE SHALL NOT EXCEED THE PAYMENT, IF ANY, RECEIVED BY CELLPHONE-MATE, INC. FOR THE UNIT OF PRODUCT OR SERVICE FURNISHED OR TO BE FURNISHED, AS THE CASE MAY BE, WHICH IS THE SUBJECT OF CLAIM OR DISPUTE. IN NO EVENT SHALL SURECALL BE LIABLE FOR INCIDENTAL, CONSEQUENTIAL, OR SPECIAL DAMAGES, HOWSOEVER CAUSED.

All matters regarding this warranty shall be interpreted in accordance with the laws of the State of California, and any controversy that cannot be settled directly shall be settled by arbitration in California in accordance with the rules then prevailing of the American Arbitration Association, and judgment upon the award rendered may be entered in any court having jurisdiction thereof. If one or more provisions provided herein are held to be invalid or unenforceable under applicable law, then such provision shall be ineffective and excluded to the extent of such invalidity or unenforceability without affecting in any way the remaining provisions hereof.

SureCall has made a good faith effort to ensure the accuracy of the information in this document and disclaims the implied warranties of merchantability and fitness for a particular purpose and makes no express warranties, except as may be stated in its written agreement with and for its customers. SureCall shall not be held liable to anyone for any indirect, special or consequential damages due to omissions or errors. The information and specifications in this document are subject to change without notice.

© 2017. All Rights Reserved. All trademarks and registered trademarks are the property of their respective owners.

SureCall, Inc
48346 Milmont Drive
Fremont, California 94538, USA
888.365.6283 | www.surecall.com