



# 1/2" CROWN AIR STAPLER

**Model** 97572  
46365

## ASSEMBLY AND OPERATING INSTRUCTIONS



Diagrams within this manual may not be drawn proportionally.

Due to continuing improvements, actual product may differ slightly from the product described herein.

**Distributed exclusively by Harbor Freight Tools®.**

3491 Mission Oaks Blvd., Camarillo, CA 93011

Visit our website at: <http://www.harborfreight.com>



**Read this material before using this product. Failure to do so can result in serious injury.**

**SAVE THIS MANUAL.**

Copyright© 2008 by Harbor Freight Tools®. All rights reserved. No portion of this manual or any artwork contained herein may be reproduced in any shape or form without the express written consent of Harbor Freight Tools.

**For technical questions or replacement parts, please call 1-800-444-3353.**

## Specifications

ITEM	DESCRIPTION
Overall Dimensions	8-1/2" x 1-7/8" x 5-3/4"
Wrenches	3mm and 4mm
Staple Specs.	1/2" Crown, 20GA, 1/4"-5/8"
Operating Pressure	55-95 PSI
CFM	4-6
Magazine Capacity	100 Staples
Air Inlet Size	1/4" NPT
Net Weight	2.05 Lb.

## Save This Manual

You will need the manual for the safety warnings and precautions, assembly instructions, operating and maintenance procedures, parts list and diagram. Keep your invoice with this manual. Write the invoice number on the inside of the front cover. Keep the manual and invoice in a safe and dry place for future reference.

## Safety Warnings and Precautions

**WARNING: When using tool, basic safety precautions should always be followed to reduce the risk of personal injury and damage to equipment.**

**Read all instructions before using this tool!**

1. **Keep work area clean.** Cluttered areas invite injuries.
2. **Observe work area conditions.** Do not use machines or power tools in damp or wet locations. Don't expose to rain. Keep work area well lit. Do not use electrically powered tools in the presence of flammable gases or liquids.
3. **Keep children away.** Children must never be allowed in the work area. Do not let them handle machines, tools, or extension cords.
4. **Store idle equipment.** When not in use, tools must be stored in a dry location to inhibit rust. Always lock up tools and keep out of reach of children.
5. **Do not force tool.** It will do the job better and more safely at the rate for which it was intended. Do not use inappropriate attachments in an attempt to exceed the tool capacity.
6. **Use the right tool for the job.** Do not attempt to force a small tool or attachment to do the work of a larger industrial tool. There are certain applications for which this tool was designed. Do not modify this tool and do not use this tool for a purpose for which it was not intended.

7. **Dress properly.** Do not wear loose clothing or jewelry as they can be caught in moving parts. Protective, electrically non-conductive clothes and non-skid footwear are recommended when working. Wear restrictive hair covering to contain long hair.
8. **Use eye and ear protection.** Always wear ANSI approved impact safety goggles.
9. **Do not overreach.** Keep proper footing and balance at all times. Do not reach over or across running machines.
10. **Maintain tools with care.** Keep tools sharp and clean for better and safer performance. Follow instructions for lubricating and changing accessories. Inspect tool cords periodically and, if damaged, have them repaired by an authorized technician. The handles must be kept clean, dry, and free from oil and grease at all times.
11. **Disconnect power.** Unplug tool when not in use.
12. **Remove adjusting keys and wrenches.** Check that keys and adjusting wrenches are removed from the tool or machine work surface before plugging it in.
13. **Avoid unintentional starting.** Do not carry any tool with your finger on the trigger, whether it is plugged in or not.
14. **Stay alert.** Watch what you are doing, use common sense. Do not operate any tool when you are tired.
15. **Check for damaged parts.** Before using any tool, any part that appears damaged should be carefully checked to determine that it will operate properly and perform its intended function. Check for alignment and binding of moving parts; any broken parts or mounting fixtures; and any other condition that may affect proper operation. Any part that is damaged should be properly repaired or replaced by a qualified technician.
16. **Guard against electric shock.** Prevent body contact with grounded surfaces such as pipes, radiators, ranges, and refrigerator enclosures.
17. **Replacement parts and accessories.** When servicing, use only identical replacement parts. Use of any other parts will void the warranty. Only use accessories intended for use with this tool. Approved accessories are available from Harbor Freight Tools.
18. **Do not operate tool if under the influence of alcohol or drugs.** Read warning labels on prescriptions to determine if your judgment or reflexes are impaired while taking drugs. If there is any doubt, do not operate the tool.
19. **Use proper size and type extension cord.** If an extension cord is required

for the Air Compressor, it must be of the proper size and type to supply the correct current to the tool without heating up. Otherwise, the extension cord could melt and catch fire, or cause electrical damage to the tool. If you are using the tool outdoors, use an extension cord rated for outdoor use. (signified by “WA” on the jacket).

21. **Maintenance.** For your safety, service and maintenance should be performed regularly by a qualified technician.

**Note:** Performance of this tool (if powered by line voltage) may vary depending on variations in local line voltage. Extension cord usage may also affect tool performance.

## Special Warnings for this Tool

It is especially important that you read and comply with the following safety precautions.

1. Never, under any circumstances, press the tip of this tool against another person or yourself.
2. Excess air may remain in the tool even after the tool is disconnected from the air supply. For this reason, be especially careful never to carry this tool with your finger on the trigger, and do not press the tip against any surface even when the tool is not connected to an air supply.
3. While using this tool, be sure to keep fingers, hands and all other body parts away from the tip of the tool.
4. Never use combustible gas as a power source.
5. Never use gasoline or other flammable liquids to clean the Stapler.
6. Do not exceed the maximum operating pressure of 95 PSI as stated in the Specifications Chart and warning label.
7. Ear protection is required for the operator and others in the work area.
8. Never attempt to drive staples on top of other staples.
9. Never attempt to keep the Trigger depressed with tape or wire.
10. Never leave the tool unattended or connected to the air supply when not in use.
11. Do not throw the tool or use it as a hammer to knock material into place.
12. Avoid prolonged use of the Stapler, and do not use this tool if you have back, neck or other bodily injuries that might be aggravated by the jerking motion of the tool. Stop using this tool if you experience pain in your arms or hands.

13. Do not use this tool if it is not loaded, as this will accelerate wear on the tool.
14. Be sure all hoses and fittings are free from damage and dirt. Replace any part that does not appear to be operating properly.

**Warning: People with pacemakers should consult with their physician(s) before using this product; operation of equipment in close proximity to a heart pacemaker could cause interference or failure of the pacemaker.**

**Warning: The warnings, cautions, and instructions discussed in this instruction manual cannot cover all possible conditions and situations that may occur. It must be understood by the operator that common sense and caution are factors which cannot be built into this product, but must be supplied by the operator.**

## Unpacking

When unpacking, check to make sure all parts listed on Page 7 are included.

If any parts are missing or broken, please call Harbor Freight Tools at the number on the cover of this manual.

## Maintenance

1. Do not store the Stapler in cold or freezing temperatures. If you are operating the Stapler in cold weather, use a permanent antifreeze as lubricant. Certain drying agents may damage o-rings and seals, so be sure to check these periodically.
2. It is recommended that you use an Oiler with this tool, especially if you use this tool regularly. Be sure to check the oil level in the Oiler before each use, and during prolonged periods of use.
3. If you are not using an Oiler, you must lubricate the Stapler before and after each use. Be sure to disconnect the tool from the air supply if you are lubricating it by hand. To lubricate this tool: add 5-6 drops of air tool lubrication to the Air Inlet. Do not use detergent oil or oil adhesives. Run the Stapler for a short time after lubrication and wipe off all excess oil.
4. A filter (not included) can be used to remove liquid and solid impurities which may rust or block internal parts and mechanisms. Periodically check the Filter and drain any water.

## Air Connection

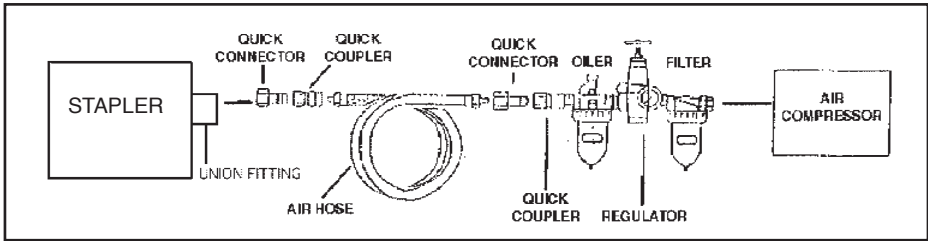

Note: Air Compressor is not supplied.

You may use Quick-Couplers and Quick-Connectors (not supplied) as shown in the diagram above. Do not connect Couplers directly to the Air Inlet. Doing so will increase the overall bulk of the tool and strain the inlet threads.

1. Read and follow all safety precautions as listed on Pages 2-5 of this manual.
2. Acquire a Union Fitting (not supplied) and screw into the Air Plug [32, see Assembly Diagram on Page 8]. Tighten with a wrench.
3. Attach a Quick-Connector (not supplied) to the Union Fitting if desired. This allows quick exchange of the Air Hose to other air tools.
4. If staples do not drive down tightly, adjust to a higher pressure setting until satisfactory. Reduce air pressure if the staples are being driven too deep.

This air tool requires lubrication during operation. For best results, it is recommended to have an Oiler and Water Filter in line with the Air Supply as shown. This will extend the life of the tool.

## Loading the Stapler

When loading, the Stapler must be disconnected from the Air Compressor Hose.

1. Only use the proper size and type of staple with this tool, as specified in the chart on Page 2.
2. Disconnect tool from the air supply.
3. Depress the Click Lever [34] to release the spring-loaded Magazine Assembly [51] from the Upper Magazine [47]. Slide the Magazine Assembly out as far as it will go. See Figure A, right.
4. Turn the Stapler upside down. Place a full clip of staples inside the Upper Magazine so the pointed ends of the staples are directed away from the tool.

Figure A



- Slide the Magazine Assembly back into place until it clicks.

## Operation

- Grip the Body [18] of the Stapler with both hands and press the Nozzle [19] against the surface you wish to staple. Be sure to keep your hands, fingers and other body parts away from the Nozzle.
- Depress the Trigger [28] to activate the Stapler.

Your 1/2" Crown Air Stapler is easy to load and fun to use. With its comfortable grip and lightweight body, your Stapler is an ideal tool for working with upholstery, insulation, picture frames and more.

## Parts List

ITEM	DESCRIPTION	ITEM	DESCRIPTION
1	Screw 5 x 22	29	Step Pin up5 x 17.5
2	Exhaust Cover	30	O-Ring 31.42 x 2.62
3	Compression Spring	31	Tail Cover
4	Seal, Air	32	Air Plug
5	Cylinder Cap	33	Compression Spring
6	O-Ring 11.8 x 2.4	34	Click Lever
7	Piston Set	35	Step Pin up5 x 26
8	Washer 7.3 x 4.7 x 0.8	36	O-Ring 17.3 x 3
9	Head Valve Piston	37	Piston Head
10	Piston Stopper	38	Driver Blade Pin
11	O-Ring 26.6 x 2.4	39	Outer Spring Pin 4 x 10
12	O-Ring 21.3 x 3	40	Inner Spring Pin 2.5 x 10
13	Collar	41	Driver Blade
14	O-Ring 33 x 2	42	Screw 4 x 16
15	Cylinder	43	Driver Guide
16	Bumper	44	Spacer
17	Gasket	45	Screw 4 x 8
18	Body	46	Stopper
19	Nozzle	47	Upper Magazine
20	Seal, Air	48	Screw 4 x 8
21	Trigger Valve Head	49	Extension Spring
22	Trigger Valve Stem	50	Pusher
23	O-Ring 3.8 x 1.5	51	Magazine Assembly
24	Trigger Valve Guide	52	Cylinder Cap Set
25	O-Ring 9.8 x 1.9	53	Head Valve Piston Set
26	Compression Spring	54	Collar Set
27	E-Ring up2.5	55	Cylinder Assembly
28	Trigger	56	Trigger Valve Set

### PLEASE READ THE FOLLOWING CAREFULLY

THE MANUFACTURER AND/OR DISTRIBUTOR HAS PROVIDED THE PARTS DIAGRAM IN THIS MANUAL AS A REFERENCE TOOL ONLY. NEITHER THE MANUFACTURER NOR DISTRIBUTOR MAKES ANY REPRESENTATION OR WARRANTY OF ANY KIND TO THE BUYER THAT HE OR SHE IS QUALIFIED TO MAKE ANY REPAIRS TO THE PRODUCT OR THAT HE OR SHE IS QUALIFIED TO REPLACE ANY PARTS OF THE PRODUCT. IN FACT, THE MANUFACTURER AND/OR DISTRIBUTOR EXPRESSLY STATES THAT ALL REPAIRS AND PARTS REPLACEMENTS SHOULD BE UNDERTAKEN BY CERTIFIED AND LICENSED TECHNICIANS AND NOT BY THE BUYER. THE BUYER ASSUMES ALL RISK AND LIABILITY ARISING OUT OF HIS OR HER REPAIRS TO THE ORIGINAL PRODUCT OR REPLACEMENT PARTS THERETO, OR ARISING OUT OF HIS OR HER INSTALLATION OF REPLACEMENT PARTS THERETO.

# Assembly Drawing

**NOTE:** Some parts are listed and shown for illustration purposes only and are not available individually as replacement parts.

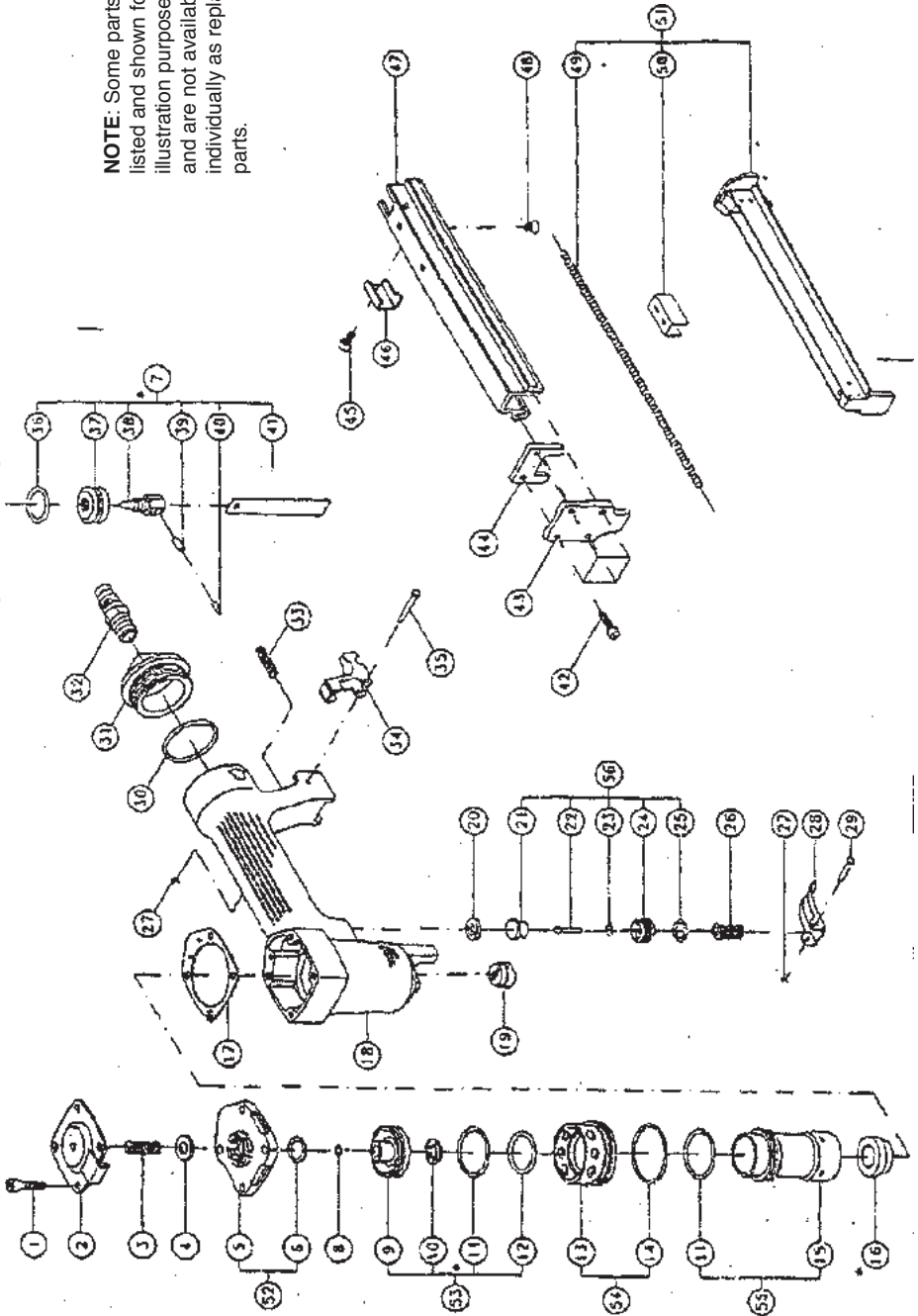



## 90 Day Warranty

Harbor Freight Tools Co. makes every effort to assure that its products meet high quality and durability standards, and warrants to the original purchaser that this product is free from defects in materials and workmanship for the period of 90 days from the date of purchase. This warranty does not apply to damage due directly or indirectly, to misuse, abuse, negligence or accidents, repairs or alterations outside our facilities, criminal activity, improper installation, normal wear and tear, or to lack of maintenance. We shall in no event be liable for death, injuries to persons or property, or for incidental, contingent, special or consequential damages arising from the use of our product. Some states do not allow the exclusion or limitation of incidental or consequential damages, so the above limitation of exclusion may not apply to you. THIS WARRANTY IS EXPRESSLY IN LIEU OF ALL OTHER WARRANTIES, EXPRESS OR IMPLIED, INCLUDING THE WARRANTIES OF MERCHANTABILITY AND FITNESS.

To take advantage of this warranty, the product or part must be returned to us with transportation charges prepaid. Proof of purchase date and an explanation of the complaint must accompany the merchandise. If our inspection verifies the defect, we will either repair or replace the product at our election or we may elect to refund the purchase price if we cannot readily and quickly provide you with a replacement. We will return repaired products at our expense, but if we determine there is no defect, or that the defect resulted from causes not within the scope of our warranty, then you must bear the cost of returning the product.

This warranty gives you specific legal rights and you may also have other rights which vary from state to state.

**3491 Mission Oaks Blvd. • PO Box 6009 • Camarillo, CA 93011 •  
(800) 444-3353**