

**CENTRAL PNEUMATIC®**

---

---

# **AIR NAILER/STAPLER 2-IN-1 KIT**

Model 97524  
40116

## **ASSEMBLY and OPERATING INSTRUCTIONS**



Diagrams within this manual may not be drawn proportionally.  
Due to continuing improvements, actual product may differ slightly from the product described herein.

**Distributed exclusively by Harbor Freight Tools®.**

3491 Mission Oaks Blvd., Camarillo, CA 93011

Visit our website at: <http://www.harborfreight.com>



**Read this material before using this product.  
Failure to do so can result in serious injury.  
SAVE THIS MANUAL.**

---

Copyright© 2007 by Harbor Freight Tools®. All rights reserved. No portion of this manual or any artwork contained herein may be reproduced in any shape or form without the express written consent of Harbor Freight Tools.

**For technical questions or replacement parts, please call 1-800-444-3353.**

## Specifications

Air Inlet	1/4" - 18 NPT
Recommended Air Pressure	60 - 100 PSI, 100 PSI Max.
Magazine Capacity	100 Nails or 80 Staples
Safety Feature	Single Sequential Safety Trip Mechanism
Nail Size	.039-.042" Shank (18 Gauge), 5/8" - 2" L
Staple Size	1/4" Crown, .039-.042" Shank (18 Gauge), 1/2" - 1 1/2" L
Accessories: Oil Dropper, 2 Wrenches, 1 Coupler Plug	

**Note:** Performance of the compressor (if powered by line voltage) may vary depending on variations in local line voltage. Extension cord usage may also affect tool performance.

## Save This Manual

You will need the manual for the safety warnings and precautions, assembly instructions, operating and maintenance procedures, parts list and diagram. Keep your invoice with this manual. Write the invoice number on the inside of the front cover. Keep the manual and invoice in a safe and dry place for future reference.

## Safety Warnings and Precautions



**WARNING:** When using tool, basic safety precautions should always be followed to reduce the risk of personal injury and damage to equipment.

**Read all instructions before using this tool!**

1. **Keep work area clean.** Cluttered areas invite injuries.
2. **Observe work area conditions.** Do not use machines or power tools in damp or wet locations. Do not expose to rain. Keep work area well lit. Do not use electrically powered tools in the presence of flammable gases or liquids.
3. **Keep children away.** Children must never be allowed in the work area. Do not let them handle machines, tools, extension cords, or air hoses.
4. **Store idle equipment.** When not in use, tools must be stored in a dry location to inhibit rust. Always lock up tools and keep out of reach of children.
5. **Use the right tool for the job.** Do not attempt to force a small tool or attachment to do the work of a larger industrial tool. There are certain applications for which this tool was designed. It will do the job better and more safely at the rate for which it was intended. Do not modify this tool and do not use this tool for a purpose for which it was not intended.
6. **Dress properly.** Do not wear loose clothing or jewelry as they can be caught in moving parts. Protective, electrically non-conductive clothes and non-skid footwear are recommended when working. Wear restrictive hair covering to contain long hair.
7. **Do not overreach.** Keep proper footing and balance at all times. Do not reach over or across running machines or air hoses.

8.  **Use eye and ear protection.** Always wear ANSI approved impact safety goggles and appropriate hearing protection. Wear a full face shield if you are producing metal filings or wood chips. Wear an ANSI approved dust mask or respirator when working around metal, wood, and chemical dusts and mists. Other people in the work area must also wear ANSI approved impact safety goggles.
9. **Maintain tools with care.** Keep tools clean for better and safer performance. Follow instructions for lubricating and changing accessories. Inspect tool cords and air hoses periodically and, if damaged, have them repaired by an authorized technician. The handle must be kept clean, dry, and free from oil and grease at all times. Do not operate a tool if any portion of the tool's operating controls are inoperable, disconnected, altered or not working properly.
10. **Disconnect Air Hose and release any built-up air pressure.** Never service the Nailer, clear jams, or disassemble with the air hose attached. Always release any built-up air even after disconnecting hose. Disconnect the Nailer when not in use.
11. **Remove adjusting keys and wrenches.** Check that keys and adjusting wrenches are removed from the tool or machine work surface before attaching to an air source.
12. **Avoid unintentional starting.** Be sure the trigger is in the Off position when not in use and before plugging in. Do not carry any tool with your finger on the trigger, whether it is attached to an air source or not. Do not point the tool towards yourself or anyone whether it contains fasteners or not.
13. **Stay alert.** Watch what you are doing, use common sense. Do not operate any tool when you are tired.
14. **Check for damaged parts.** Before using any tool, any part that appears damaged should be carefully checked to determine that it will operate properly and perform its intended function. Check for alignment and binding of moving parts; any broken parts or mounting fixtures; and any other condition that may affect proper operation. Any part that is damaged should be properly repaired or replaced by a qualified technician. Do not use the tool if the trigger does not operate properly.
15. **Guard against electric shock.** Prevent body contact with grounded surfaces such as pipes, radiators, ranges, and refrigerator enclosures.
16. **Replacement parts and accessories.** This product is to be repaired and serviced only by a qualified technician. When this product is serviced, only identical replacement parts should be used. Use of any other parts will void the warranty. Only use accessories intended for use with this tool. Approved accessories are available from Harbor Freight Tools.
17. **Do not operate tool if under the influence of alcohol or drugs.** Read warning labels if taking prescription medicine to determine if your judgement or reflexes are impaired while taking drugs. If there is any doubt, do not operate the tool.
18. **Use proper size and type extension cord.** If an extension cord is required, it must be of the proper size and type to supply the correct current to the compressor without heating up. Otherwise, the extension cord could melt and catch fire, or cause electrical damage to the tool. Check your air compressor's manual for the appropriate size cord. It is also possible that the use of an extension cord may cause your circuit breaker to

trip or your panel fuse to break. If this happens, either use the compressor without an extension cord or find a larger amperage circuit to use.

19. **Maintenance.** The maintenance outlined in the maintenance section should be performed regularly. For your safety, this product should be serviced or repaired regularly only by a qualified technician.

20. **Compressed air only.** Never use combustible gas as a power source.

21.  **Do not load nails with the trigger or safety depressed.** Unintentional firing may occur. Do not load nails when the air hose is connected to the tool. Always assume that the tool contains fasteners.

22. **Disconnect air supply before loading Nailer.** Before reloading (or making any adjustments to) the Nailer make sure that the compressed air is disconnected.

23. **Fire fasteners into an appropriate work surface only.** Do not attempt to fire fasteners into surfaces too hard to penetrate. Do not drive fasteners on top of other fasteners, or at too steep of an angle. Fasteners can ricochet causing personal injury. Never fire the Nailer into the air, or point it toward yourself or another person. Always wear ANSI approved safety goggles during use, maintenance, and reloading.

24. **Do not fire fasteners too close to the edge of a workpiece.** They may split the workpiece and fly free, causing personal injury.

25. **Take caution as some woods contain preservatives such as copper chromium arsenate (CCA) which can be toxic.** When stapling or nailing these materials extra care should be taken to avoid inhalation and minimize skin contact.

**WARNING: Some dust created by power sanding, sawing, grinding, drilling, and other construction activities, contain chemicals known [to the State of California] to cause cancer, birth defects or other reproductive harm.**

Some examples of these chemicals are:

- Lead from lead-based paints
- Crystalline silica from bricks and cement or other masonry products
- Arsenic and chromium from chemically treated lumber

(California Health & Safety Code 25249.5, *et seq.* )

26. **Stay within air pressure capacity.** Never operate the Nailer above 100 PSI.

27. **Hold tool away from head and body.** During operation the Nailer may kick back causing injury.

28. **Transport Nailer safely.** Always disconnect air supply when moving the tool in the workplace. Carry the tool by the handle and avoid contact with the trigger.

**Warning: The warnings, cautions, and instructions discussed in this instruction manual cannot cover all possible conditions and situations that may occur. It must be understood by the operator that common sense and caution are factors which cannot be built into this product, but must be supplied by the operator.**

## Unpacking

When unpacking, check to make sure the parts listed on page 9 are included. If any parts are missing or broken, please call Harbor Freight Tools at the number on the cover of this manual as soon as possible.

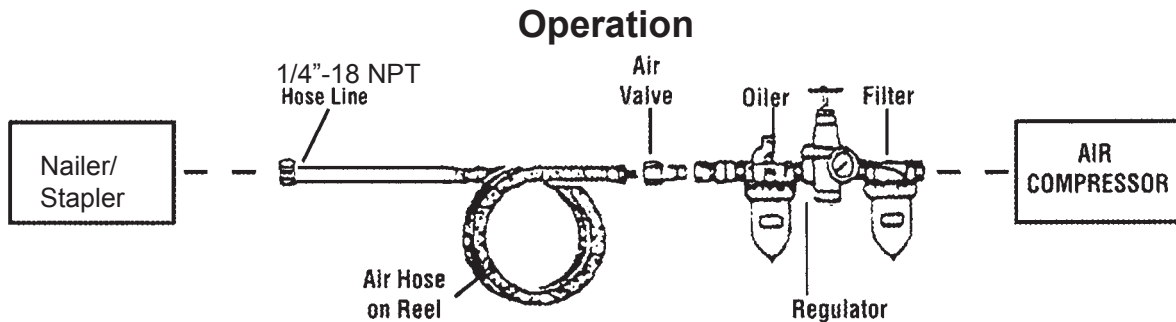

### Recommended Air Line Components

For best service you should incorporate an oiler, regulator, and inline filter, as shown in the diagram above. Hoses, couplers, oilers, regulators, and filters are all available at Harbor Freight Tools.

1. You will need to prepare a 1/4" air connector (sold separately) to connect to the air inlet on the Nailer/Stapler First, wrap the 1/4" air connector (not included) with pipe thread seal tape before connecting to a 3/8" ID Air Source Hose (not included). Connect the Air Source Hose to the Air Plug (86).

**Note:** If you are not using an automatic oiler system, before operation, add a few drops of Pneumatic Tool Oil to the airline connection. Add a few drops more after each hour of continual use.

2. Set the air pressure on your compressor to 60-100 PSI. Do not exceed the maximum air pressure of 100 PSI.
3. Check the air connection for leaks.

**Note:** The amount of air pressure effects how deep the nails/staples will be driven. It is suggested that you experiment on scrap material.

4. Check the air connection for leaks and disconnect the Nailer/Stapler.

## Testing The Single Sequential Safety Trip Mechanism

**Warning:** Even though the nailer should be empty during this procedure, **ALWAYS** point the nailer/Stapler at a piece of scrap wood when testing.

1. The Nailer/Stapler should not fire if the nose is not depressed against the workpiece. This tool has a contact safety tip mechanism, which is designed to prevent inadvertent firing. The tool will only fire if the Safety (52) is resting on the workpiece prior to pulling the Trigger (39).
2. Make sure the tool is disconnected from the air supply.

## Operation - Testing The Single Sequential Safety Trip Mechanism (continued)

3. Empty the magazine of nails or staples.
4. Check that the Trigger (39) and the Safety (52) on the nose of the tool, move freely, without sticking.
5. Connect the air supply to the tool at the Air Plug (86) and set at the recommended 70-100 PSI, and not over the maximum 100 PSI.
6. Test the tool by depressing the Safety (52) on the nose of the tool against the workpiece without pulling the Trigger (39). **The tool must not cycle (fire)**. If it cycles (fires), stop immediately and take the tool to a qualified service technician for repair.
7. Hold the tool away, or off of the workpiece. The Safety (52) or nose of the tool should return to its original position. Squeeze the Trigger (39). **The tool should not cycle (fire)**. If it cycles (fires), stop immediately and take the tool to a qualified service technician.
8. Depress the Safety (52) against the workpiece and squeeze the Trigger (39). **The tool must cycle (fire) once only**. Release the trigger and squeeze it again. **The tool must cycle (fire) once only**. With the Trigger held, carefully lift the nailer and press it against the workpiece again. **The tool must not cycle (fire)**. If it fails to act in the manner explained in bold, have it repaired by a qualified service technician.

### Loading Nails or Staples



**ALWAYS WEAR ANSI APPROVED IMPACT SAFETY GOGGLES WHEN RELOADING OR DOING ANY OTHER MAINTENANCE ON THIS TOOL.** Other people in the work area must also wear ANSI approved impact safety goggles.

**Warning! Make sure the Nailer/Stapler is not attached to the air hose whenever loading the tool.**

1. Depress the Latch (73) and pull back on the Tail Cover (78), opening Magazine A (67).
2. Insert the brad nails into the Magazine, letting the pointed end ride on the rail of Magazine B (61). If loading staples, fit the crown of the staples so they fit over, and ride on the rail of the Magazine B (61).
3. After the nails or staples reach the nose of the tool, close Magazine A (67).

**Note:** The window gauge on Magazine A (67) lets you know how many nails or staples remain.

### Operating the Stapler/Nailer

1. Attach the Nailer/Stapler to the air supply at the Air Plug (86). Start your compressor and check the pressure making sure it is set at the recommended 70-100 PSI and not over the maximum 100 PSI.
2. To fire, place the nose of the Nailer/Stapler on the workpiece. The Nailer/Stapler should not fire if the Safety (52) is not depressed. Once depressed, gently and briefly squeeze the Trigger (39) once. **Do not fire repeatedly**; nails or staples could bounce off of one another, damaging the work piece or causing PERSONAL INJURY.

**Anytime any maintenance or repairs are done (including clearing jams), FIRST:**

1. Disconnect the Nailer/Stapler from the air hose.
2. Empty Magazine A (67) completely.
3. Attempt to fire the Nailer/Stapler into a piece of scrap wood to ensure that it is disconnected and is incapable of firing any staples.
4. **Always leave Magazine A (67) open during maintenance. The Magazine is spring-loaded and may cause parts or a fastener to fly out of the Nailer/Stapler.**

### Clearing Jams

1. Disconnect tool from air hose, empty Magazine A (67) of fasteners, release any built-up air pressure, and leave the magazine open, as explained above.
2. While doing this step and the next 2 steps, hold the Nailer/Stapler pointed away from you and any other people or fragile objects - see *Figure 1*. Remove all three Safety Cover Bolts (53) on the Safety Cover (54) - see *Figure 2*.
3. Lift the Safety Cover (54) off the top of the Nailer/Stapler - see *Figure 3*.
4. Carefully slide the Driver Cover (57) off around the Safety (52). Note the position of the tab on the Driver Cover (57). Remove the jammed fastener; pliers may be necessary to remove a stuck fastener.
5. Inspect the Driver (17A) for bends or breakage. If it is damaged, do not use the tool until it is repaired by a qualified technician.
6. Lightly oil the Driver (17A) and replace the Driver Cover (57) with the tab in the Cover facing the Driver Guide (58). Replace the Safety Cover (54), being careful to line up the bolt holes and fit the Safety (52) into the slot. Replace and securely tighten all of the Safety Cover Bolts (53). Make sure that the Safety (52) moves without sticking.
7. Reload the Nailer/Stapler.
8. Reconnect the Nailer/Stapler to the air hose.
9. Press the Safety (52) of the Nailer/Stapler against an appropriate piece of scrap wood.
10. Test fire the Nailer/Stapler several times, checking for proper operation.
11. Disconnect the Nailer/Stapler, remove the fasteners, and store the Nailer/Stapler in a location out of children's reach.

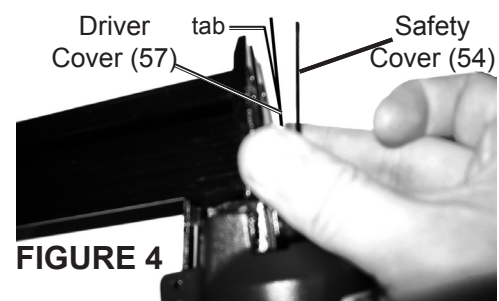
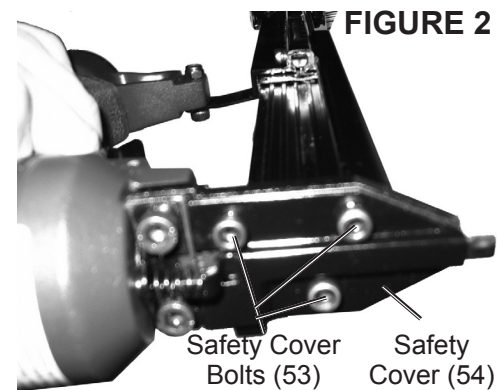

**Anytime any maintenance or repairs are done, FIRST:**

1. Disconnect the Nailer/Stapler from the air hose.
2. Empty Magazine A (67) completely.
3. Attempt to fire the Nailer/Stapler into a piece of scrap wood to ensure that it is disconnected and is incapable of firing any staples.
4. **Always leave Magazine A (67) open during maintenance. The Magazine is spring-loaded and may cause parts or a fastener to fly out of the Nailer/Stapler.**

## Troubleshooting Guide

**Stop using the Nailer/Stapler immediately if any of the following problems occur.**

**Repairs and part replacements must be done only by a qualified technician.**

***All procedures in bold on this chart are to be attempted only by a qualified technician.***

Problem	Likely Cause	Solution
Air leaking at Trigger area.	O-Rings in Valve Body (100) are damaged.	<b>Replace O-Rings and check contact trip operation.</b>
Air leaking between Housing and Nose.	1. Loose screws in Housing. 2. Damaged O-Rings/Bumper (94).	1. Tighten screws. 2. <b>Replace O-Rings or Bumper (94).</b>
Air leaking between Housing and Cap (4).	1. Loose screws. 2. Damaged Gasket (9).	1. Tighten Screws. 2. <b>Replace Gasket (9).</b>
Runs slowly or has power loss.	1. Insufficient oil. 2. Broken Spring in Cylinder Cap (4). 3. Exhaust is blocked.	1. Lubricate as instructed. 2. <b>Replace Compression Spring (8).</b> 3. <b>Clean Cap (4) or replace damaged parts.</b>
Tool skips a nail.	1. Worn Bumper (94) or damaged Pusher Spring. 2. Dirt in Driver Guide (58). 3. Inadequate airflow to Nailer/Stapler. 4. Worn or dry O-Ring on Piston. 5. Damaged O-Ring on Trigger Valve. 6. Cap Gasket (9) leaking.	1. <b>Replace Bumper (94) or Pusher Spring.</b> 2. Clean channels in Driver Guide (58). 3. Check hose and compressor fittings. 4. <b>Replace or lubricate O-Rings.</b> 5. <b>Replace O-Rings.</b> 6. <b>Replace Gasket (9).</b>
Fasteners are jammed.	1. Guide on driver is worn. 2. Fasteners are wrong size or damaged. 3. Magazine or Nose screws are loose. 4. Driver (17A) is damaged.	1. <b>Replace Guide.</b> 2. Use correct, undamaged Fasteners. 3. Tighten screws. 4. <b>Replace Driver (17A).</b>
Nailer/Stapler will not drive down tight.	1. Rounded Driver (17A) slipping off fastener crown. 2. Lack of air pressure. 3. Slow cycling and loss of power.	1. <b>Replace Driver (17A).</b> 2. Supply correct pressure (60-100 PSI). 3. <b>Check Compression Spring (8) for broken coils or reduced length.</b> <b>Make sure Exhaust is clear.</b>
Blade driving fastener too deeply.	Worn Bumper (94) and/or Piston Spacer.	<b>Replace either or both parts.</b>

***All procedures in bold on this chart are to be attempted only by a qualified technician.***



## Maintenance

**Warning!** Always disconnect the tool from the air compressor and then empty the magazine of nails or staples before attempting to inspect or perform maintenance to the Nailer/Stapler.

1. Inspect all of the nuts and screws and make sure they are securely fastened.
2. Periodically lubricate the driving mechanism and magazine with a light oil. Wipe down with a clean cloth. Never use gasoline or flammable solvents to clean the tool.
3. Inspect your air compressor according to manufacturer's instructions.

**Warning!** If you detect any air leaks, power loss, the Nailer/Stapler skips driving, drives too deep, or not deep enough, take the Nailer/Stapler to a qualified service technician.

## Parts List

Part	Description	Part	Description	Part	Description	Part	Description
1	Exhaust Deflector	39	Trigger	61A	Magazine B	84	O-Ring
		40	Retainer Pin	62A	Steel Bar	85	End Cap
3	Hex. Bolt	41	Safety Guide	63	Pusher Unit	86	Air Plug
4	Head Cap	42	Spring Washer	64	Spring Holder	87	Collar
5	Seal	43	Hex Bolt	66	Spring	88	Fixed Ring
6	Internal Lining	44	Spring Pin	67A	Magazine A	89	O-Ring
7	O-Ring	45	Spring	68	Stopper	90	Lining Ring
8	Compression Spring	46	Screw Nut	69	Hex. Bolt	91	O-Ring
9	Gasket	47	Thumb Wheel	70	Hex. Bolt	92	Cylinder
10	O-Ring	48	Spring	71A	Nail Positioner	93	Lining Ring
11	Head Valve Piston	49	Steel Ball	72	Retaining Pin	94	Bumper
12	O-Ring	50	Stopper	73	Latch	95	Seal
13	O-Ring	51	E-Ring	74	Spring	96	Trigger Valve Upper
14	O-Ring	52	Safety	75	O-Ring	97	Trigger Plunger
		53	Safety Cover Bolt	76	Hex Bolt	98	O-Ring
16	O-Ring	54	Safety Cover	77	Cylinder Pin	99	O-Ring
17A	Piston & Driver	55	Hex. Bolt	78	Tail Cover	100	Trigger Valve Lower
26	Body	56	Spacer	79	Hex. Bolt	101	Trigger Plate
27	Nozzle	57	Driver Cover	80	Hex. Bolt	102	Non-mar Tip
35	Compression Spring	58	Driver Guide	81	Tail Hanger		
37	Spring Pin	59	Hex. Bolt	82	Lock Nut		
38	E-Ring	60	Pin	83	Hand Grip		

### PLEASE READ THE FOLLOWING CAREFULLY

THE MANUFACTURER AND/OR DISTRIBUTOR HAS PROVIDED THE PARTS DIAGRAM IN THIS MANUAL AS A REFERENCE TOOL ONLY. NEITHER THE MANUFACTURER NOR DISTRIBUTOR MAKES ANY REPRESENTATION OR WARRANTY OF ANY KIND TO THE BUYER THAT HE OR SHE IS QUALIFIED TO MAKE ANY REPAIRS TO THE PRODUCT OR THAT HE OR SHE IS QUALIFIED TO REPLACE ANY PARTS OF THE PRODUCT. IN FACT, THE MANUFACTURER AND/OR DISTRIBUTOR EXPRESSLY STATES THAT ALL REPAIRS AND PARTS REPLACEMENTS SHOULD BE UNDERTAKEN BY CERTIFIED AND LICENSED TECHNICIANS AND NOT BY THE BUYER. THE BUYER ASSUMES ALL RISK AND LIABILITY ARISING OUT OF HIS OR HER REPAIRS TO THE ORIGINAL PRODUCT OR REPLACEMENT PARTS THERETO, OR ARISING OUT OF HIS OR HER INSTALLATION OF REPLACEMENT PARTS THERETO.

# Assembly Drawing

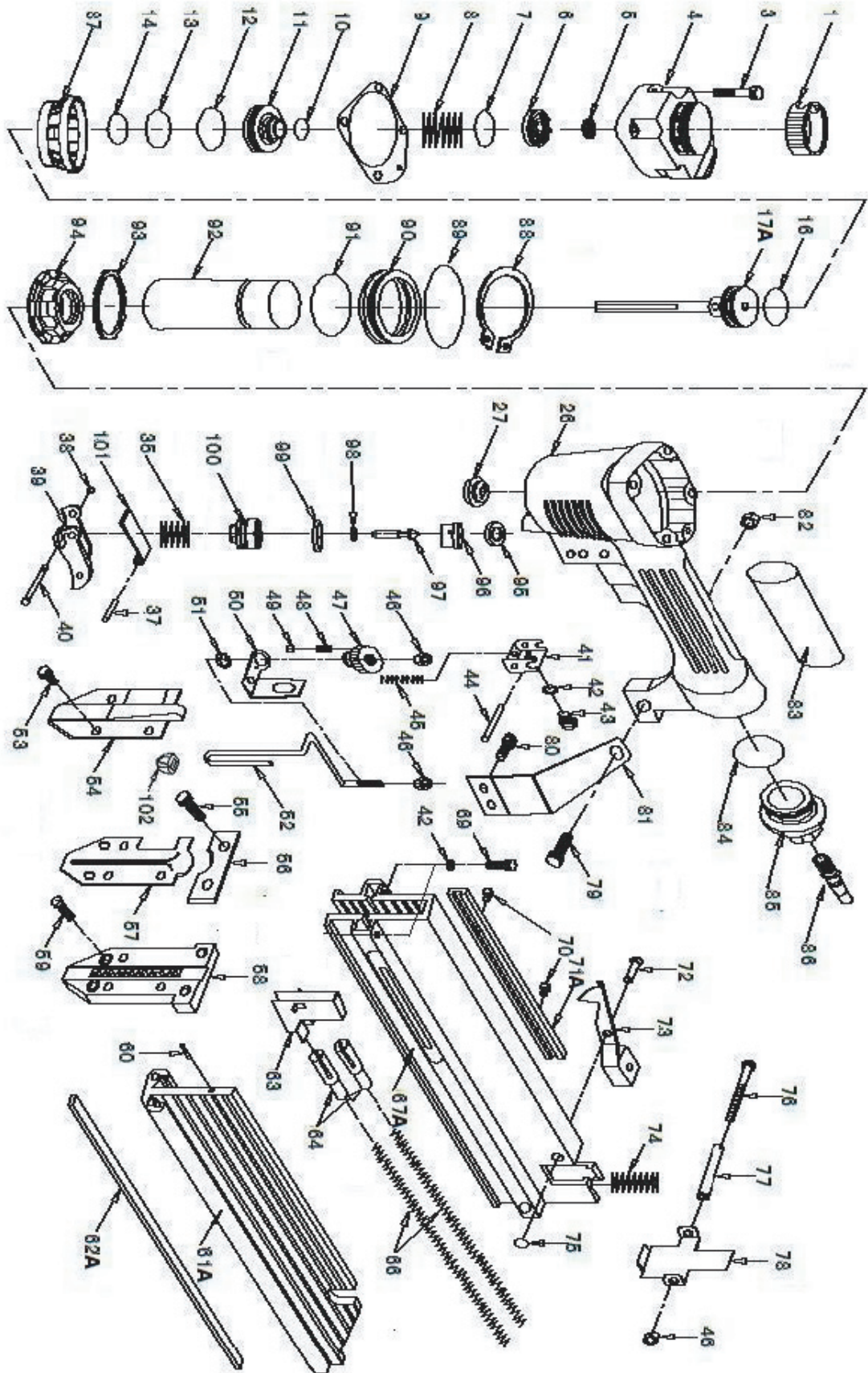

**NOTE:** Some parts are listed and shown for illustration purposes only and are not available individually as replacement parts.

---

## LIMITED 1 YEAR WARRANTY

---

Harbor Freight Tools Co. makes every effort to assure that its products meet high quality and durability standards, and warrants to the original purchaser that this product is free from defects in materials and workmanship for the period of one year from the date of purchase (90 days if used by a professional contractor or if used as rental equipment). This warranty does not apply to damage due directly or indirectly, to misuse, abuse, negligence or accidents, repairs or alterations outside our facilities, normal wear and tear, or to lack of maintenance. We shall in no event be liable for death, injuries to persons or property, or for incidental, contingent, special or consequential damages arising from the use of our product. Some states do not allow the exclusion or limitation of incidental or consequential damages, so the above limitation of exclusion may not apply to you. THIS WARRANTY IS EXPRESSLY IN LIEU OF ALL OTHER WARRANTIES, EXPRESS OR IMPLIED, INCLUDING THE WARRANTIES OF MERCHANTABILITY AND FITNESS.

To take advantage of this warranty, the product or part must be returned to us with transportation charges prepaid. Proof of purchase date and an explanation of the complaint must accompany the merchandise. If our inspection verifies the defect, we will either repair or replace the product at our election or we may elect to refund the purchase price if we cannot readily and quickly provide you with a replacement. We will return repaired products at our expense, but if we determine there is no defect, or that the defect resulted from causes not within the scope of our warranty, then you must bear the cost of returning the product.

This warranty gives you specific legal rights and you may also have other rights which vary from state to state.

**3491 Mission Oaks Blvd. • PO Box 6009 • Camarillo, CA 93011 • (800) 444-3353**